

*iGen***4500**

Digital Inverter Generator

Gasoline: 3700 Running Watts | 4500 Peak Watts

DO NOT RETURN THIS PRODUCT TO THE STORE

If you have questions or need assistance, please call customer service at 855-944-3571.

INTRODUCTION

TABLE OF CONTENTS

INTRODUCTION

DISCLAIMERS2
 ALL RIGHTS RESERVED.....2
 SPECIFICATIONS.....3

SAFETY

SAFETY DEFINITIONS.....4
 SAFETY SYMBOLS.....4
 SAFETY INSTRUCTIONS5
 SAFETY LABELS AND DECALS.....7

COMPONENTS

CONTROL PANEL COMPONENTS.....8
 GENERATOR COMPONENTS9
 DIGITAL DATA CENTER.....9

ASSEMBLY

CARTON CONTENTS10
 INITIAL OIL FILL10
 FUEL.....11
 CONNECT THE BATTERY12

OPERATION

GENERATOR LOCATION.....13
 GROUNDING.....13
 HIGH ALTITUDE OPERATION13
 REMOTE START14
 FUEL SWITCH14
 BREAK-IN PERIOD14
 FREQUENCY OF USE14
 BEFORE STARTING THE GENERATOR.....14
 STARTING THE ENGINE14

STOPPING THE ENGINE.....15
 ECO MODE.....15
 AC CIRCUIT BREAKERS15
 OVERLOAD RESET15
 POWER MANAGEMENT16
 EXTENSION CORDS16
 PARALLEL OPERATION.....17
 TRANSPORTING.....18

MAINTENANCE

MAINTENANCE SCHEDULE19
 MAINTENANCE REPLACEMENT PARTS19
 ENGINE SERVICE COVER.....19
 AIR FILTER MAINTENANCE.....19
 ENGINE OIL LEVEL CHECK20
 ENGINE OIL CHANGE21
 SPARK PLUG MAINTENANCE21
 SPARK ARRESTOR SERVICE.....22
 BATTERY MAINTENANCE.....22
 BATTERY REPLACEMENT.....22
 STORAGE.....23
 VALVE CLEARANCE24
 MANUAL CHOKE OPERATION.....24

TROUBLESHOOTING

EXPLODED VIEWS AND PARTS LISTS

ENGINE EXPLODED VIEW.....26
 ENGINE PARTS LIST27
 GENERATOR EXPLODED VIEW.....29
 GENERATOR PARTS LIST.....30

SCHEMATICS

.....32

INTRODUCTION

WARNING: Operating, servicing, and maintaining this equipment can expose you to chemicals including engine exhaust, carbon monoxide, phthalates, and lead, which are known to the State of California to cause cancer and birth defects or other reproductive harm. To minimize exposure, avoid breathing exhaust, and wear gloves or wash your hands frequently when servicing this equipment. For more information go to www.P65warnings.ca.gov.

DISCLAIMERS

All information, illustrations, and specifications in this manual were in effect at the time of publishing. The illustrations used in this manual are intended as representative reference views only. We reserve the right to make any specification or design change without notice.

ALL RIGHTS RESERVED

All rights reserved. No reproduction allowed in any form without written permission from Westinghouse Outdoor Power Equipment, LLC.

⚠ DANGER	
	Read this manual before using or performing maintenance on this product. Failure to follow the instructions and safety precautions in this manual can result in serious injury or death.

SAVE THESE INSTRUCTIONS

INTRODUCTION

SPECIFICATIONS

Specifications	iGen4500
Running Watts:	3700
Peak Watts:	4500
Rated Voltage:	120V
Rated frequency:	60 Hz
Phase:	Single phase
Total Harmonic Distortion:	≤ 3%
Engine Displacement:	224 cc
Starting Type:	Recoil, Electric Start, Remote
Fuel Capacity:	3.4 Gallons (12.8 Liters)
Fuel Type:	87–93 octane*
Oil Capacity:	0.63 US qt (0.60 L)
Oil Type:	10W-30
Spark Plug:	97109 - F7RTC
Spark Plug Gap:	0.024 - 0.032 in. (0.60 - 0.80 mm)
Valve Intake Clearance:	0.0031 – 0.0047 in (0.08 – 0.12 mm)
Valve Exhaust Clearance:	0.0051 – 0.0067 in (0.13 – 0.17 mm)
AC Grounding System:	Floating neutral
Voltage Regulator:	Digital
Alternator Type:	Permanent magnet
Maximum Ambient Temperature:	104°F (40°C)
Certifications:	<ul style="list-style-type: none">• EPA• CARB• CSA Group

*Ethanol content of 10% or less. DO NOT use E15 or E85.

UPDATES

The latest User Manual for your Westinghouse generator can be found under our support tab. <https://westinghouseoutdoorpower.com/pages/manuals>

Or scan the following QR code with your smartphone camera to be directed to the link.



NOTICE

This product is designed and rated for continuous operation at ambient temperatures up to 104°F (40°C). If needed, this product can be operated at temperatures ranging from 5°F (15°C)–122°F (50°C) for short periods. If the product is exposed to temperatures outside of this range during storage, it should be brought back within this range before operation. This product must always be operated outdoors in a well-ventilated area and far away from doors, windows, and other vents.

Maximum wattage and current are subject to and limited by such factors as fuel BTU content, ambient temperature, altitude, engine conditions, etc. Maximum power decreases about 3.5% for each 1,000 feet above sea level, and will also decrease about 1% for each 10°F (6°C) above 60°F (16°C) ambient temperature.

PRODUCT REGISTRATION

For trouble-free warranty coverage, it is important to register your Westinghouse generator.

You can register by:

- Completing and mailing the product registration card included in the carton.
- Registering your product online at: <https://westinghouseoutdoorpower.com/pages/warranty-registration>
- Scanning the following QR code with your smartphone camera. You will be directed to the mobile registration link.



- Sending the following product information to:

Westinghouse Outdoor Power
Warranty registration
777 Manor Park Drive
Columbus, OH 43228

For Your Records

Date of Purchase: _____

Model Number: _____

Serial Number: _____

Place of Purchase: _____

IMPORTANT: Keep your purchase receipt for trouble-free warranty coverage.

SAFETY

SAFETY

SAFETY DEFINITIONS

The words DANGER, WARNING, CAUTION and NOTICE are used throughout this manual to highlight important information. Make sure that the meanings of this safety information is known to all who operate, perform maintenance on, or are near the generator.



This safety alert symbol appears with most safety statements. It means attention, become alert, your safety is involved! Please read and abide by the message that follows the safety alerts symbol.

⚠ DANGER

Indicates a hazardous situation which, if not avoided, will result in death or serious injury.

⚠ WARNING

Indicates a hazardous situation which, if not avoided, could result in death or serious injury.

⚠ CAUTION

Indicates a hazardous situation which, if not avoided, could result in minor or moderate injury.

NOTICE

Indicates a situation which can cause damage to the generator, personal property, and/or the environment, or cause the equipment to operate improperly.

Note: Indicates a procedure, practice or condition that should be followed for the generator to function in the manner intended.

SAFETY SYMBOLS

Follow all safety information contained in this manual and on the generator.

Symbol	Description
	Safety Alert Symbol
	Electrocution Hazard
	Asphyxiation Hazard
	Burn Hazard. Do not touch hot surfaces.
	Electrical Shock Hazard
	Fire Hazard
	Maintain Safe Distance
	Lifting Hazard
	Read Manufacturer's Instructions
	Do Not Operate in Wet Conditions

SAFETY INSTRUCTIONS

CORRECT USAGE

Example location to reduce risk of carbon monoxide poisoning

- ONLY use outside and downwind, far away from windows, doors and vents.
- Direct exhaust away from occupied spaces

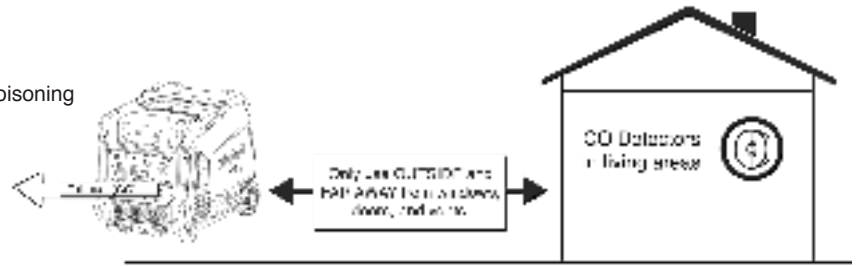

INCORRECT USAGE

Do not operate in any of the following locations:

- Near any door, window, or vent
- Garage
- Basement
- Crawl Space
- Living Area
- Attic
- Entry Way
- Porch
- Mudroom

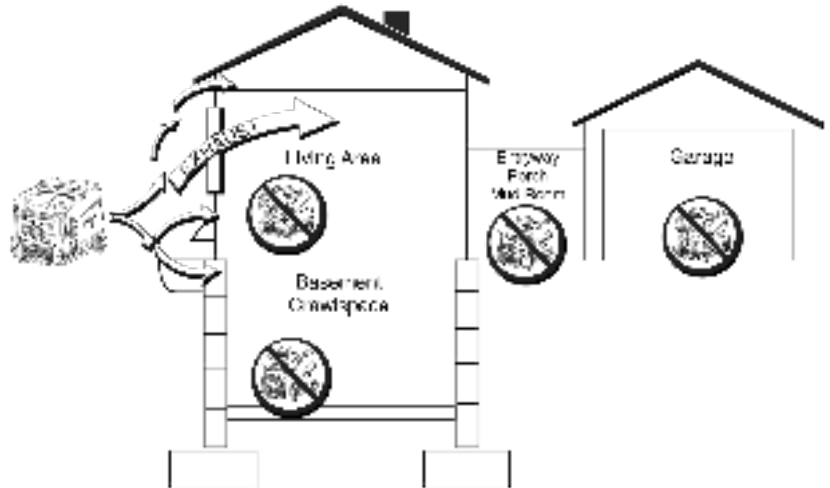

NOTICE

Install battery-powered carbon monoxide detectors or plug-in carbon monoxide detectors with battery back-up in living areas.

⚠ DANGER

Using a generator indoors CAN KILL YOU IN MINUTES. Generator exhaust contains carbon monoxide. This is a poison you cannot see or smell.

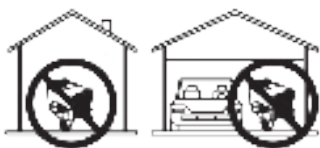

NEVER use inside a home or garage, EVEN if doors and windows are open.

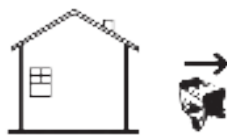

Only use OUTSIDE and far away from windows, doors, and vents.

⚠ DANGER

Fire and electrocution hazard. Do not connect to a building's electrical system unless the generator and transfer switch have been properly installed and the electrical output has been verified by a qualified electrician. The connection must isolate the generator power from utility power and must comply with all applicable laws and electrical codes.

⚠ DANGER

Electrocution hazard. Never use the generator in a location that is wet or damp. Never expose the generator to rain, snow, water spray, or standing water while in use. Protect the generator from all hazardous weather conditions. Moisture or ice can cause a short circuit or other malfunction in the electrical circuit.

SAFETY

GENERAL SAFETY PRECAUTIONS

- Never use the generator to power medical support equipment.
- Do not operate the generator when you are tired or under the influence of drugs, alcohol, or medication.
- Do not use generator with electrical cords which are worn, frayed, bare, or otherwise damaged.
- All electrical tools and appliances operated from this generator must be properly grounded by use of a third wire or be double-insulated.
- When this generator is used to supply a building wiring system the generator must be installed by a qualified electrician and connected to a transfer switch as a separately derived system in accordance with NFPA 70, National Electrical Code.
- If you begin to feel sick, dizzy, or weak while using the generator, move to fresh air IMMEDIATELY. See a doctor, as you can have carbon monoxide poisoning.
- Only use OUTSIDE and far away from windows, doors, and vents as recommended by the US Department of Health and Human Services Centers for Disease Control and Prevention. Your specific home and/or wind conditions may require additional distance.
- While operating and storing, keep at least 5 feet of clearance on all sides of the generator, including overhead. Allow the generator to cool a minimum of 30 minutes before storage. Heat created by the muffler and exhaust gases could be hot enough to cause serious burns and/or ignite combustible objects.
- Do not touch the muffler or engine. They are very HOT and will cause severe burns. Do not put body parts or any flammable or combustible materials in the direct path of the exhaust.
- Always remove any tools or other service equipment used during maintenance away from the generator before operating.
- Avoid skin contact with engine oil or gasoline. Wear protective clothing and equipment. Wash all exposed skin with soap and water.

FUEL SAFETY

- Store fuel in a container approved for gasoline.
- Do not smoke when filling the generator with gasoline.
- Do not allow the generator's gas tank to overflow when filling.
- Shut down the engine and allow it to cool for five minutes before adding gasoline or oil to the generator.
- Never remove the fuel cap when the generator is running. Shut off the engine and allow the unit to cool at least five minutes. Remove the fuel cap slowly to release pressure, keep fuel from escaping around the cap, and to avoid the heat from the muffler igniting fuel vapors. Tighten the fuel cap securely after refueling.

- Wipe spilled fuel from the unit.
- Never attempt to burn off spilled fuel.
- Never overfill the fuel tank. Leave room for fuel to expand. Overfilling the fuel tank can result in a sudden overflow of gasoline and result in spilled gasoline coming in contact with HOT surfaces.
- Spilled fuel can ignite. If fuel is spilled on the generator, wipe up any spills immediately. Dispose of rag properly. Allow area of spilled fuel to dry before operating the generator.
- Wear eye protection while refueling.
- Never use gasoline as a cleaning agent.
- Store any containers containing gasoline in a well-ventilated area, away from any combustibles or source of ignition.

GASOLINE AND GASOLINE VAPOR (GAS)

⚠ DANGER

Fire and explosion hazard. Gasoline is highly explosive and flammable and can cause severe burns or death.

- In case of a gas fire, do not attempt to extinguish the flame if the fuel valve is in the gas position. Introducing an extinguisher to a generator with an open fuel valve could create an explosion hazard.
- Gas has a distinctive odor, this will help detect potential leaks quickly.
- Gas vapors can cause a fire if ignited.
- Gasoline is a skin irritant and needs to be cleaned up immediately if it comes in contact with the skin.

When starting the generator:

- Make sure that the fuel cap, air filter, spark plug, fuel lines, and exhaust system are properly in place.
- If you spill any gasoline on the tank, allow it to fully evaporate before operating.
- Make sure the generator is on a flat surface before operating.

When transporting or servicing the generator:

- Disconnect the spark plug wire to prevent accidental starting.

When storing the generator:

- Store away from sparks, open flames, pilot lights, heat, and other sources of ignition.
- Do not store gas near furnaces, water heaters, or any other appliances that produce heat or have automatic ignitions.

SAFETY LABELS AND DECALS

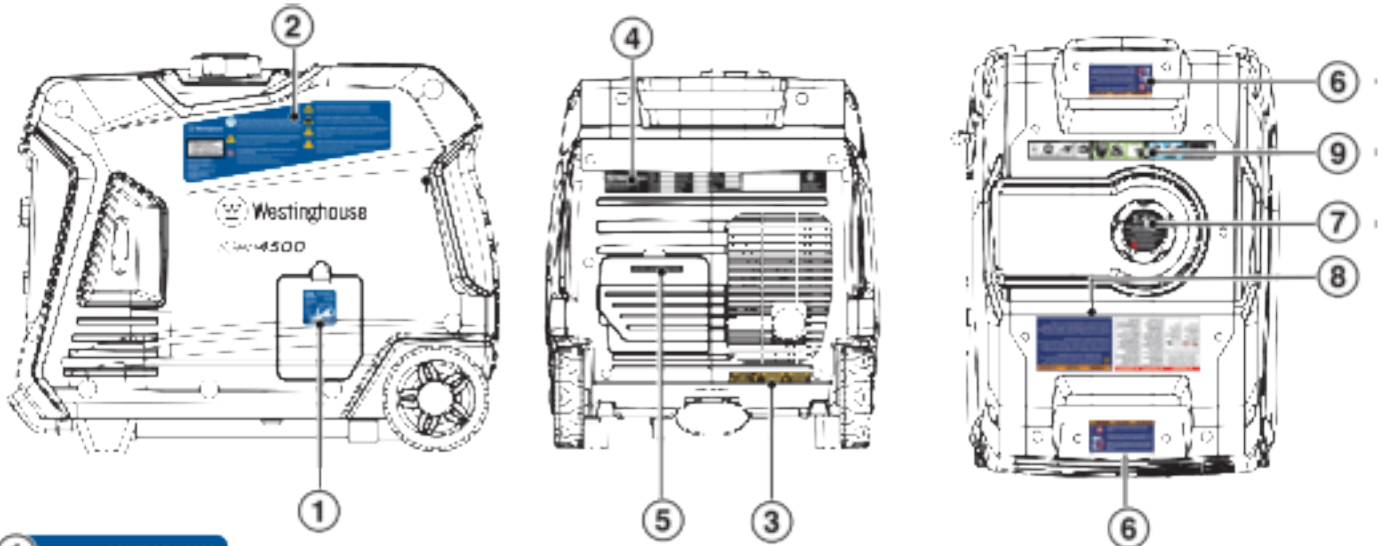

1 OIL ACEITE DE MOTOR / HUILE MOTEUR

Oil Capacity (maximum oil volume)
Capacidad máxima de aceite
8.0 QT / 7.6 L / 80.9 QZ / 800 ML

Safe Operating Range

SAE 10W-30

5 BATTERY | BATERÍA | BATTERIE

3 CAUTION HOT SURFACES / **PRECAUCIÓN** SUPERFICIES CALIENTES / **ATTENTION** SURFACES CHAUDES

6 WARNING | PELIGRO | ATTENTION

Operate, store, and transport on firm level surface. Do not rest on exhaust panel. Tilting can cause fuel spillage.

Operar, almacenar y transportar sobre una superficie firme y nivelada. No descansar sobre el panel de escape. La inclinación puede provocar un derrame de combustible.

Utilisez, stockez et transportez sur une surface plane et ferme. Ne vous appuyez pas sur le panneau d'échappement. L'inclinaison peut provoquer un déversement de carburant.

4 Westinghouse

Model	WCH4500
Serial Number	
Production Date	
Production Plant	
Country of Origin	
Part Number	
Part Name	
Part Description	
Part Quantity	
Part Unit of Measure	
Part Material	
Part Color	
Part Finish	
Part Weight	
Part Dimensions	
Part Notes	

Serial Number

2 Westinghouse

Read owners manual before using or performing maintenance on this product. Failure to follow the instructions and safety precautions in this manual can result in serious injury or death. Lire et comprendre les instructions de l'opérateur avant de commencer l'utilisation de ce générateur. Ne pas suivre les instructions de sécurité de ce manuel peut entraîner de graves blessures ou la mort.

Failure to properly ground generator can result in electrocution. No conectar a tierra correctamente al generador puede provocar una electrocución. Lire l'avis de sécurité situé à l'arrière du générateur pour obtenir une électrocinction.

Do not operate in wet conditions. Electrical shock may result and could be fatal. No opere en condiciones húmedas. Puede producirse una descarga eléctrica y podría ser fatal. No opere en condiciones húmedas. Riesgo de electrocución, posiblemente mortal.

WARNING Generator exhaust contains carbon monoxide, a poisonous gas you cannot see or smell. AWARNING: El escape del generador contiene monóxido de carbono, un gas venenoso que no puede ver ni oler. AWARNING: Le gaz d'échappement du générateur contient du monoxyde de carbone, un gaz toxique que vous ne pouvez ni voir ni sentir.

For use in a weather protected well ventilated area. Para uso en un área bien ventilada, protegida contra el intemperie. Prévoyez une ventilation adéquate. Ne pas utiliser dans un endroit confiné.

Keep any flammable items away from this equipment. Mantenga los artículos inflamables lejos de este equipo. Tenir tout objet inflammable à l'écart de cet équipement.

Hazardous voltage! Do not connect the AC output to any indoor wiring. Evitar peligros. No conecte la salida de CA a ningún cableado interior. Evitez tout câblage intérieur à l'arrière de cet équipement.

FOR ELECTRICAL EQUIPMENT ONLY / SOLO PARA EQUIPO ELÉCTRICO / POUR MATÉRIEL ÉLECTRIQUE SEULEMENT

8 DANGER / **PELIGRO** / **DANGER**

Using a generator less than 20 minutes can cause carbon monoxide poisoning. Operar un generador por menos de 20 minutos puede provocar una intoxicación por monóxido de carbono.

NEVER use inside a home or garage. EVEN IF doors and windows are open.

Only use OUTSIDE and far away from windows, doors, and vents.

NE JAMAIS utiliser à l'intérieur d'une maison ou d'un garage. MÊME SI les portes et les fenêtres sont ouvertes.

WARNING / **PELIGRO** / **ATTENTION**

Fuel is flammable which can cause burns resulting in death or serious injury. Allow engine to cool at least 2 minutes before refueling. Do not add fuel above red maximum fill ring. Never add fuel to a hot or running generator.

El combustible es inflamable, lo que puede provocar quemaduras y provocar la muerte o lesiones graves. Deje que el motor se enfríe por lo menos 2 minutos antes de repostar. No agregue combustible por encima del anillo de llenado máximo rojo. Nunca agregue combustible a un generador caliente o en funcionamiento.

Le carburant est inflammable, ce qui peut provoquer des brûlures entraînant la mort ou des blessures graves. Laissez le moteur refroidir au moins 2 minutes avant de faire le plein. N'ajoutez pas de carburant au-dessus de l'anneau de remplissage maximum rouge. N'ajoutez jamais de carburant à un générateur chaud ou en marche.

7 DO NOT OVERFILL

3.4 Gal 12.8L

USE FUEL STABILIZER FOR STORAGE

UTILISEZ UN STABILISATEUR DE CARBURANT POUR LE STOCKAGE

EL USO DEL ESTABILIZADOR DE COMBUSTIBLE PARA EL ALMACENAMIENTO

• 87 MINIMUM OCTANE
• 87 OCTANO MÍNIMO
• 87 OCTANO MÍNIMO

9 START

HANDL START: Push manual start button.

ELECTRIC START: Push electric start button.

REMOTE START: Push remote start button.

COMPONENTS

COMPONENTS

CONTROL PANEL COMPONENTS

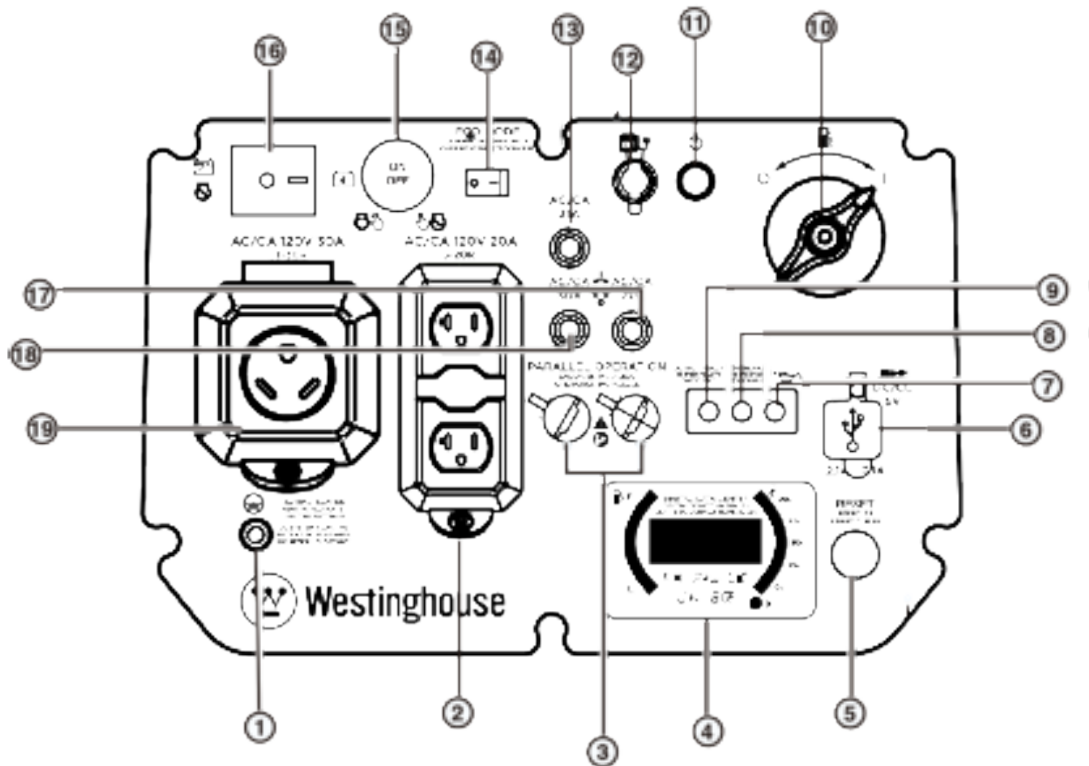

- 1. Ground Terminal:** The ground terminal is used to externally ground the generator.
- 2. 120 Volt AC, 20 Amp Duplex NEMA 5-20R Receptacle:** Receptacle can supply a maximum of 20 Amps.
- 3. Parallel Operation Outlets:** A compatible Westinghouse Inverter Generator can be connected for additional power output.
- 4. LED Data Center:** Displays remaining run time (F), power output in kW (P), fuel level in liters (L), voltage output (V), and lifetime hours.
- 5. Overload Reset:** The generator inverter will automatically switch OFF all AC output to protect the generator if overloaded or if there is a short circuit in a connected appliance.
- 6. USB Ports:** Two-port 5V/2.1A USB outlet. Accepts Type A USB plugs.
- 7. Low Oil LED:** Indicates low oil level. When the oil level in the crankcase falls below the safe operating limit, the low oil level indicator will illuminate and the generator will automatically shut off the engine.
- 8. Overload LED:** Indicates that the generator is overloaded. See page 17.
- 9. Output Ready LED:** Illuminates when the generator is operating normally. Indicates the generator is producing electrical power at the receptacles.
- 10. Fuel Switch:** Used to turn gas valve open or closed.
- 11. Battery Indicator:** Indicates that power is ON. Light will remain illuminated while the unit is ON.
- 12. Battery Charging Port:** Used to charge the battery with the included battery charger.
- 13. Main Circuit Breaker:** The main circuit breaker controls total output of all outlets to protect the generator from overload or short circuit.
- 14. Eco Mode:** Eco mode minimizes fuel consumption and noise by adjusting the engine RPM to the minimum required for the current load.
- 15. Push-Button Start/Stop:** Push once to automatically start the engine. Push again to stop the engine.
- 16. Battery Switch:** Turns battery ON and OFF. Must be ON before electric start or remote start.
- 17. 20 Amp AC Circuit Breaker:** Circuit breaker limits the current that can be delivered through the NEMA 5-20R receptacle to 20 Amps.
- 18. 30 Amp AC Circuit Breaker:** Circuit breaker limits the current that can be delivered through the NEMA TT-30 receptacle to 30 Amps.
- 19. 120 Volt AC, 30 Amp NEMA TT-30R Receptacle:** Receptacle can supply a maximum of 30 Amps.

COMPONENTS

GENERATOR COMPONENTS

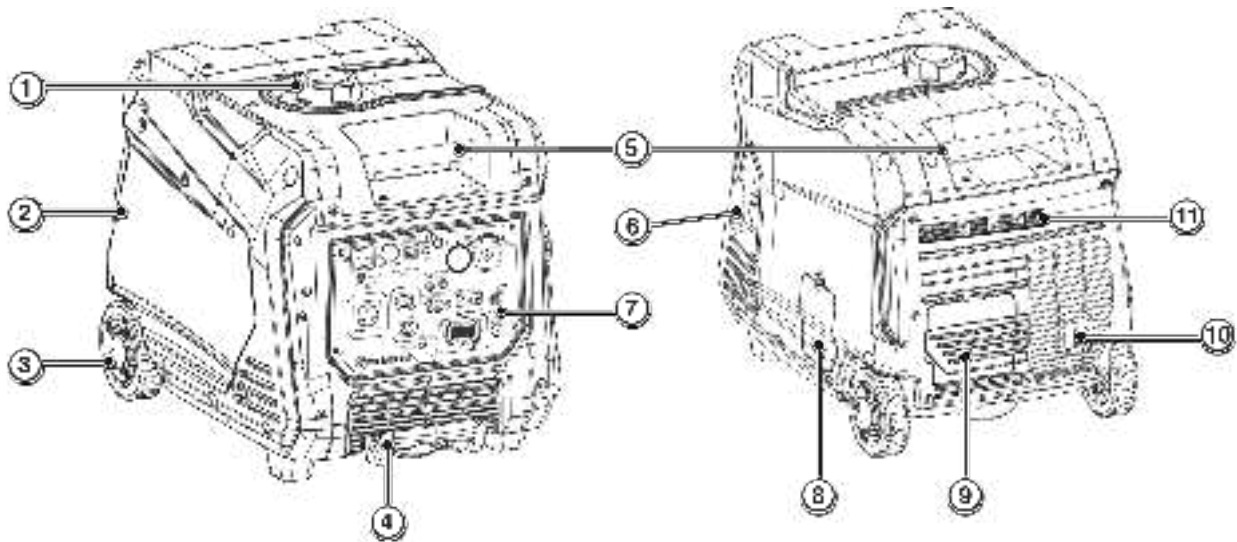

- 1. Fuel Cap:** Add unleaded fuel here. Close the cap until it clicks.
- 2. Engine Service Cover:** Cover provides access to the engine, air cleaner, carburetor, and spark plug.
- 3. Transport Wheels:** Wheels allow one-handed maneuverability when used with the extendable handle.
- 4. Extendable Handle:** Extend and retract the handle by pushing the locking button.
- 5. Carry Handles:** Built-in handles allow easy, two-person transport.
- 6. Recoil Handle:** Pull the recoil handle to manually start the engine.
- 7. Control Panel:** The control panel contains the outlets and operational controls.
- 8. Oil Access Cover:** Cover provides access to the oil fill cap/dipstick and oil drain plug.
- 9. Battery Access Cover:** Cover provides access to the battery and quick-connect plug.
- 10. Muffler and Spark Arrestor:** The spark arrestor prevents sparks from exiting the muffler.
- 11. Model Information Label:** Provides model serial number, voltage/amps, and power rating information.

DIGITAL DATA CENTER

Fuel remaining and power output percentage LEDs are continuously displayed. Push the Mode button to cycle through the data display modes.

DATA DISPLAY

The diagram shows a control panel with two semi-circular LED displays. The left display is labeled '% Fuel Remaining' and the right is labeled '% Power Output'. Below the displays is a 'Mode Button'. The panel also has a 'DIGITAL DATA CENTER' label and a 'Rec.' label.

Remaining Run Time: Displays time remaining with current fuel level and power output.	Power Output: Displays electrical power output to receptacles in kilowatts.	Fuel level: Displays current fuel level in liters.
Voltage: Displays current voltage output of inverter.	Lifetime Hours: Displays the total run time of the inverter.	

ASSEMBLY

ASSEMBLY

CARTON CONTENTS

⚠ CAUTION

Weight hazard. Always have assistance when lifting the generator.

1. Carefully open the carton.
2. Remove and save the instruction manual, oil bottle, oil funnel, spark plug socket wrench, and battery charger.
3. Remove and discard the packing tray.
4. Unfold the top of the plastic bag enclosing the generator.
5. Carefully cut the vertical corners of the carton to access the generator.
6. Recycle or dispose of the packaging materials properly.

CARTON CONTENTS

- User manual
- Quick Start Guide
- Remote start key fob (attached to recoil starter)
- Bottle of SAE 10W-30 Oil
- Battery charger
- Spark plug wrench
- Oil Funnel
- Screwdriver

If any parts are missing, contact our service team at service@wpowereq.com or call 1-855-944-3571.

INITIAL OIL FILL

NOTICE

THIS GENERATOR HAS BEEN SHIPPED WITHOUT OIL. Do not attempt to crank or start engine before it has been properly serviced with recommended oil. Failure to add engine oil before starting will result in serious engine damage.

NOTICE

Use of 2-stroke/cycle oil or other unapproved oil types can cause severe engine damage that is not covered under warranty.

The included, recommended oil type for typical use is 10W-30 engine oil. If running the generator in extreme temperatures, refer to the following chart.

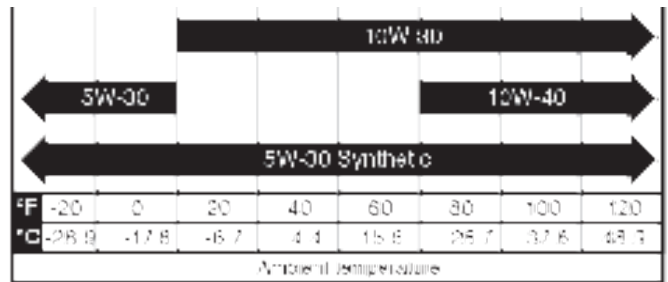

1. On a level surface, remove the oil access cover and oil dipstick.

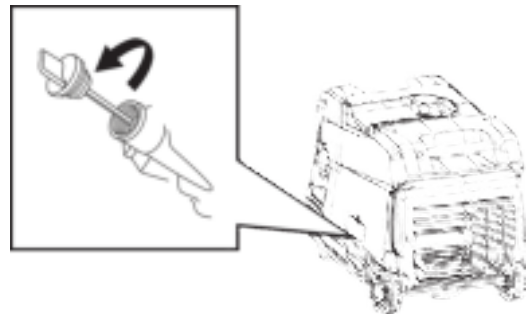

2. Using the supplied funnel and oil, add oil into the engine.

Note: As residual oil from the factory may remain in the engine, add the oil incrementally near the end of the bottle to prevent overfilling the engine. See Engine Oil Level Check in the Maintenance section.

3. Replace the oil dipstick and hand-tighten.
4. Replace the oil access cover.

FUEL

⚠ WARNING

Fire and explosion hazard. Never use a gasoline container, gasoline tank, or any other fuel item that is broken, cut, torn or damaged.

⚠ DANGER

Fire and explosion hazard. Do not overfill fuel tank. Fill only to the red fill ring located in the in-tank fuel screen filter. Overfilling may cause fuel to spill onto engine causing a fire or explosion hazard.

⚠ DANGER

Fire and explosion hazard. Never refuel the generator while the engine is running. Always turn the engine off and allow the generator to cool for two minutes before refueling.

NOTICE



Do not use E15 or E85 fuel in this product. Engine or equipment damage caused by stale fuel or the use of unapproved fuels (such as E15 or E85 ethanol blends) is not covered by warranty. Only use unleaded gasoline containing up to 10% ethanol.

FUEL REQUIREMENTS

- CLEAN, FRESH, unleaded gasoline, 87–93 octane.
- Up to 10% ethanol (gasohol) is acceptable (where available; non-ethanol fuel is recommended).
- DO NOT use E85 or E15.
- DO NOT use a gas oil mix.
- DO NOT modify the engine to run on alternate fuels.
- DO NOT fuel indoors.
- DO NOT create a spark or flame while fueling.

USING FUEL STABILIZER

Adding a fuel stabilizer (not included) extends the usable life of fuel and helps prevent deposits from forming that can clog the fuel system. Follow the manufacturer's instructions for use.

Always mix the correct amount of fuel stabilizer to gasoline in an approved gasoline container before fueling the generator. Run the generator for five minutes to allow the stabilizer to treat the entire fuel system.

FILLING THE FUEL TANK

1. Turn the generator OFF and allow to cool for a minimum of two minutes before fueling.
2. Place the generator on level ground in a well ventilated area.
3. Clean area around fuel cap and remove the cap slowly.

NOTICE

Only fill the tank from an approved gasoline container. Make sure the gasoline container is internally clean and in good condition to prevent fuel system contamination.

4. Slowly add the recommended fuel. Do not overfill. Fill only to the red maximum fill ring on the fuel screen filter visible in the filler neck.

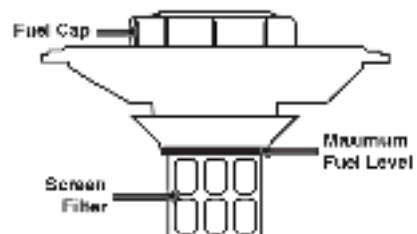

ASSEMBLY

5. Install the fuel cap and tighten until a click is heard.

NOTICE

Fuel can damage paint and plastic. Use caution when filling the fuel tank. Damage caused by spilled fuel is not covered under warranty.

NOTICE

Clean the fuel screen filter of debris before and after each fueling. Remove the fuel screen filter by slightly compressing it while removing it from the fuel tank.

CONNECT THE BATTERY

1. Push down the battery access cover tab and pull the cover forward to remove it.



2. Verify that the rubber battery strap is firmly securing the battery in place. If loose, pull on the strap and hook it onto the mounting base.

Note: If the strap is loose behind the battery, remove the battery, reconnect the strap, replace the battery, then thread the strap under the battery quick connect cables.

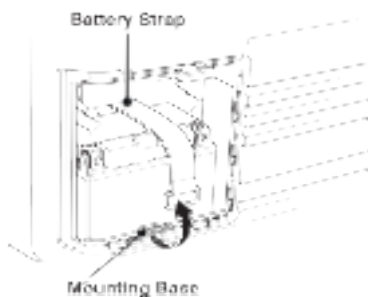

3. A quick-connect battery plug is pre-installed on the battery. Remove the cable tie securing the plugs then push firmly to connect them.

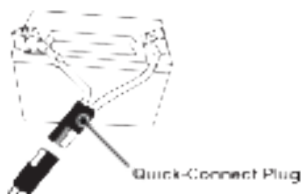

4. Align the tabs on the bottom of the battery access cover with the generator case then push to reinstall the cover.

Note: The generator is equipped with a battery charging feature. Once the engine is running, a small charge will slowly recharge the battery.



OPERATION

GENERATOR LOCATION

Read and understand all safety information before starting the generator.

⚠ DANGER

Using a generator indoors CAN KILL YOU IN MINUTES. Generator exhaust contains carbon monoxide. This is a poison you cannot see or smell.

 <p>NEVER use inside a home or garage, EVEN IF doors and windows are open.</p>	 <p>Only use OUTSIDE and far away from windows, doors, and vents.</p>
-----------------------------------------------------------------------------------------------------------------------------------------------------------------	--------------------------------------------------------------------------------------------------------------------------------------------------------

NEVER operate the generator inside any building, including garages, basements, crawlspaces, sheds, enclosure, or compartment, including the generator compartment of a recreational vehicle.

⚠ DANGER

Electrocution hazard. Never use the generator in a location that is wet or damp. Never expose the generator to rain, snow, water spray, or standing water while in use. Protect the generator from all hazardous weather conditions. Moisture or ice can cause a short circuit or other malfunction in the electrical circuit. Using a generator or electrical appliance in wet conditions, such as rain or snow, or near a pool or sprinkler system, or when your hands are wet, could result in electrocution.

⚠ WARNING

Fire hazard. Only operate the generator on a solid, level surface. Operating the generator on a surface with loose material such as sand or grass clippings can cause debris to be ingested by the generator that could block cooling vents or the air intake system. Allow the generator to cool for 30 minutes before transport or storage.

The generator should be on a flat, level surface at all times (Even while not in operation). The generator must have at least 5 ft. (1.5 m) of clearance from all combustible material.

Do not operate the generator in the back of a SUV, camper, trailer, truck bed (regular, flat, or otherwise), under stairs, next to walls or buildings, or in any other location that will not allow for adequate cooling of the generator and/or the muffler. DO NOT contain generators during operation.

⚠ DANGER

Asphyxiation hazard. Place the generator in a well-ventilated area. DO NOT place the generator near vents or intakes where exhaust fumes could be drawn into occupied or confined spaces. Carefully consider wind and air currents when positioning generator.

GROUNDING

⚠ WARNING

Shock hazard. Failure to properly ground the generator can result in electric shock.

The generator neutral is floating. The generator ground terminal is connected to the frame of the generator, the metal non-current-carrying parts of the generator, and the ground terminals of each receptacle. The generator (stator winding) is isolated from the frame and from the AC receptacle ground pin. Electrical devices that require a grounded receptacle pin connection may not function properly.

If this generator will be used only with cord and plug equipment connected to the receptacles mounted on the generator, National Electric Code does not require that the unit be grounded. However, other methods of using the generator may require grounding to reduce the risk of shock or electrocution.

Before using the ground terminal, consult a qualified electrician, electrical inspector, or local agency having jurisdiction for local codes or ordinances that apply to the intended use of the generator.

NOTICE

Only use grounded 3-prong extension cords, tools, and appliances, or double-insulated tools and appliances.

HIGH ALTITUDE OPERATION

Engine power is reduced the higher you operate above sea level. Output will be reduced approximately 3.5% for every 1000 feet of increased altitude from sea level.

High altitude adjustment is required for operation at altitudes over 5,000 ft. (1524 m). Operation without this adjustment will cause decreased performance, increased fuel consumption, and increased emissions. Operation of the engine at altitudes below 2,000 ft. (762 m) with the high altitude kit is not recommended.

NOTICE

Do not operate the generator at altitudes below 2,000 ft. (762 m) with the high altitude kit installed. Engine damage may occur.

High Altitude Carburetor Kit: Part# 518913-01

OPERATION

REMOTE START

⚠ WARNING

Verify that the area around the generator is clear before remote starting the generator.

The remote start key fob included with the generator should be attached to the recoil handle or control panel. If your unit was shipped without a key fob, contact Westinghouse customer service.

The generator can be started remotely from up to 99 feet (30 meter) using the remote start key fob.

Note: As the batteries in the remote start key fob drain, operational distance will decrease.

Remote replacement batteries: (2) CR2016

Replacement remote: Part# 130172

REPROGRAMMING THE REMOTE START

If the remote start key fob is replaced or needs re-paired to the generator, follow this procedure.

1. Turn the generator battery switch to the ON position.
2. Push and hold the ON/OFF button for 10 seconds, then release. The start indicator light will flash green.

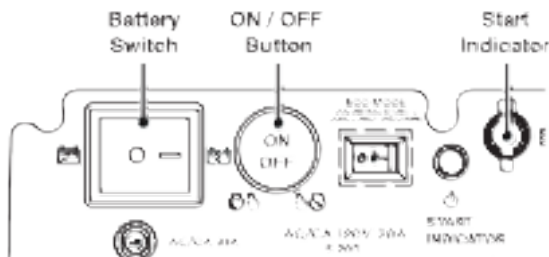

3. Push the ON button on the remote start key fob. It will pair with generator automatically and the start indicator light on the generator will stop flashing.

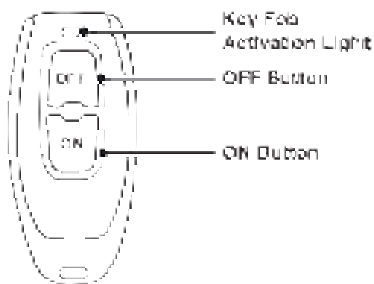

FUEL SWITCH

Turn the fuel switch fully to the right for gasoline operation.



Turn the fuel switch fully to the left to shut the fuel valve OFF.



BREAK-IN PERIOD

For proper break-in, do not exceed 50% of the rated running watts (1850 watts) during the first five hours of operation.

Vary the load occasionally to allow stator windings to heat and cool and help seat the piston rings.

FREQUENCY OF USE

If the generator will be used on an infrequent or intermittent basis (more than one month before next use), refer to the Battery Maintenance and Storage sections of this manual for information regarding battery and fuel deterioration.

BEFORE STARTING THE GENERATOR

- Verify that the generator is placed in a safe, appropriate location.
- Make sure the generator is on a dry, flat, and level surface.
- Verify that the engine is filled with oil.
- Verify that all loads are disconnected.

⚠ DANGER

Fire and explosion hazard. DO NOT move or tip the generator during operation.

STARTING THE ENGINE

1. Verify that fuel is in the gas tank.
2. Turn the fuel switch to the ON position.
3. Push the battery switch to the ON position.
4. Choose the starting method:
 - a. **Recoil Start:** Firmly grasp and pull the recoil handle slowly until you feel increased resistance, then pull rapidly.

b. Remote Start: Push and hold the ON button on the remote start key fob for one second.

c. Push-Button Start: Push and hold the engine start button for two seconds.

STOPPING THE ENGINE

1. Turn off and unplug all connected electrical loads. Never start or stop the generator with electrical devices connected.
2. Let the generator run with no load for several minutes to stabilize internal temperatures.
3. Push and hold the ON/OFF button for one second or push OFF on the remote start key fob for one second.
4. Push the battery switch to the OFF position.

Note: If the engine will not be used for two weeks or longer, refer to the Storage section for correct engine and fuel storage procedures.

ECO MODE

NOTICE

Always start the generator with ECO MODE OFF. Allow the engine speed to stabilize and the OUTPUT READY LED to illuminate before switching ECO MODE ON.

Note: Do not use ECO MODE when in parallel operation with another Westinghouse generator.

ECO MODE minimizes fuel consumption and noise by adjusting the engine RPM to the minimum required for the current load.

Turn ECO MODE ON when powering small appliances with continuous loads such as a computer or electric light.

Turn ECO MODE OFF when powering large surge loads such as an air conditioner or electric pump.

To turn on ECO MODE, verify that the OUTPUT READY LED is illuminated green, then push the switch to the ON position. If no load is present, the generator RPM will drop to idle speed. The generator will detect loads as they are applied and increase engine RPM.

To run the generator at maximum power and RPM, push the ECO MODE switch to the OFF position.

AC CIRCUIT BREAKERS

The circuit breakers will automatically switch OFF if there is a short circuit or a significant overload of the generator at each receptacle. The main circuit breaker will automatically switch OFF if the combined load of the receptacles exceeds 31 Amps.

If an AC circuit breaker switches OFF automatically, check that the appliance is working correctly and it does

not exceed the rated load capacity of the circuit before resetting the AC circuit breaker ON.

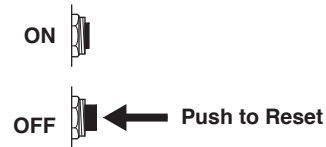

OVERLOAD RESET

The generator will automatically switch OFF all AC output to protect the generator if overloaded or if there is a short circuit in a connected appliance. However, the engine will continue to run. Marginal overloading that temporarily illuminates the OVERLOAD LED may shorten the service life of the generator.

OVERLOAD on the control panel will illuminate red and the green OUTPUT READY will be OFF.

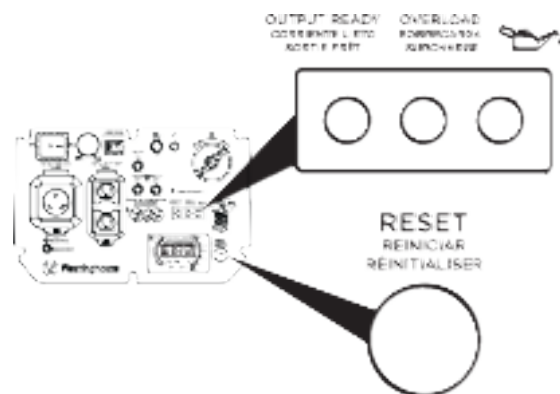

To restore AC output:

1. Turn off and unplug all connected electrical loads.
2. Push the RESET button on the control panel until the OVERLOAD LED goes OFF and the OUTPUT READY LED is illuminated.
3. Reset the circuit breakers if OFF.
4. Verify that the intended running and surge loads do not exceed the generator's capacity.
5. Reconnect electrical loads sequentially, allowing the generator to stabilize after each load is connected.

GENERATOR CAPACITY

NOTICE

Do not overload the generator's capacity. Exceeding the generator's wattage/ampere capacity can damage the generator and/or electrical devices connected to it.

Make sure the generator can supply enough continuous (running) and surge (starting) watts for the items you will power at the same time.

The total power requirements (Volts x Amps = Watts) of all

OPERATION

appliances connected must be considered. Appliance and power tool manufacturers usually list rating information near the model or serial number.

To determine power requirements:

1. Select the items you will power at the same time.
2. Total the continuous (running) watts of these items. This is the amount of power the generator must produce to keep the items running. See the wattage reference chart on the next page.
3. Estimate how many surge (starting) watts you will need. Surge wattage is the short burst of power needed to start electric motor-driven tools or appliances such as a circular saw or refrigerator. Because not all motors start at the same time, total surge watts can be estimated by adding only the item(s) with the highest additional surge watts to the total rated watts from step 2.

Example:

Tool or Appliance	Running Watts*	Starting Watts*
RV Air Conditioner (11,000 BTU)	1010	1600
TV (Tube Type)	300	0
RV Refrigerator	180	600
Radio	200	0
Light (75 Watts)	300	0
Coffee Maker	600	0
	2590 Total Running Watts*	1600 Highest Starting Watts*
	Total Running Watts	2590
	Highest Starting Watts	+ 1600
	Total Starting Watts Needed	4190

*Wattages listed are approximate. Verify actual wattage.

POWER MANAGEMENT

To prolong the life of the generator and attached devices, use care when adding electrical loads to the generator. There should be nothing connected to the generator outlets before starting the engine. The correct and safe way to manage generator power is to sequentially add loads as follows:

1. With nothing connected to the generator, start the engine as described in this manual.
2. Plug in and turn on the first load, preferably the largest load you have.
3. Permit the generator output to stabilize (engine runs smoothly and attached device operates properly).

4. Plug in and turn on the next load.
5. Again, permit the generator to stabilize.
6. Repeat steps 4 and 5 for each additional load.

Wattage Reference

Tool or Appliance	Estimated Running Watts*	Estimated Starting Watts*
Incandescent Lights (4 Quantity x 75 Watts)	300	0
TV (Tube Type)	300	0
Sump Pump (1/3 hp)	800	1300
Refrigerator or Freezer	700	2200
Well Pump (1/3 hp)	1000	2000
Furnace (1/2 hp)	800	2350
Radio	200	0
Drill (3/8", 4 amps)	440	600
Circular Saw (Heavy Duty, 7-1/4")	1400	2300
Miter Saw (10")	1800	1800
Table Saw (10")	2000	2000

*Wattages listed are approximate. Verify actual wattage.

EXTENSION CORDS

⚠ WARNING

Asphyxiation hazard. Extension cords running directly into the home increase the risk of carbon monoxide poisoning through any openings. If an extension cord running directly into your home is used to power indoor items, there is a risk of carbon monoxide poisoning to people inside the home. Always use battery-powered carbon monoxide detector (s) that meet current UL 2034 safety standards when running the generator. Regularly check the detector (s) battery.

⚠ WARNING

Asphyxiation hazard. When operating the generator with extension cords, make sure the generator is located in an open, outdoor area, far away from occupied spaces with exhaust pointed away.

⚠ WARNING

Fire and electrocution hazard. Never use worn or damaged extension cords. Damaged or overloaded extension cords could overheat, arc, and burn resulting in death or serious injury.

Before connecting an AC appliance or power cord to the generator:

- Use grounded 3-prong extension cords, tools, and

OPERATION

appliances, or double-insulated tools and appliances.

- Make sure the tool or appliance is in good working order. Faulty appliances or power cords can create a potential for electric shock.
- Make sure the electrical rating of the tool or appliance does not exceed the rated power of the generator or the receptacle being used.

EXTENSION CORD SIZING

Only use grounded 3-prong extension cords marked for outdoor use that are rated for the electrical load.

Total Amperage	Minimum Gauge, Outdoor Rated	
	Up to 50 FT (15 M)	Up to 100 FT (30 M)
Up to 10A	12	8
Up to 15A	10	8
Up to 20A	10	6
Up to 30A	8	6
Up to 35A	6	6

PARALLEL OPERATION

⚠ WARNING

Fire and electrocution hazard. Never connect or disconnect the parallel cord leads when a generator is running.

⚠ CAUTION

Correct connection of the left and right cables is very important when the generators are used with a transfer switch to supply power to a building. To avoid serious personal injury or damage to electrical devices, including the generators, do not try to power an electrical system in a building without using an approved transfer switch.

NOTICE

Connecting to a generator that is not compatible can cause a low voltage output that can damage tools and appliances powered by the generator.

Parallel operation gives you the ability to link to a compatible Westinghouse Inverter Generator with the included parallel cord for combined running and peak power output.

A Westinghouse 507PC parallel cord (purchased

separately) is also compatible. This cord can be purchased from an authorized Westinghouse Generator dealer.

Note: Compatible Westinghouse generators without parallel ports can be operated in parallel with the receptacle-mounted parallel cable, Part# 260041.

NOTICE

DO NOT use ECO MODE during parallel operation if powering large surge loads such as an air conditioner or electric pump. Engine rpm may not adjust quickly enough to provide the voltage requirements of large surge loads, causing damage to the devices or the generators.

1. On both generators, make sure the engine/fuel switch and the ECO MODE switch are in the OFF position.
2. Connect two parallel cable leads to the parallel outlets on the first generator, then connect the opposite cable leads to the other generator's parallel outlets.

Note: If powering devices directly from the generators (not connected to a building's transfer switch), you do not need to match the left/right cables to the generator's parallel outlets.

3. Start one of the generators and wait until the OUTPUT READY LED illuminates.
4. Start the second generator and wait until the OUTPUT READY LED illuminates before connecting a load.
5. Connect additional loads as described in Power Management section.
6. Unplug all loads before stopping the generators.

OPERATION

TRANSPORTING

⚠ CAUTION

Weight hazard. Always have assistance when lifting the generator.

- Allow the generator to cool a minimum of 30 minutes before transporting.
- Replace all protective covers on the generator control panel.
- Only use the generator's fixed handle(s) to lift the unit or attach any load restraints such as ropes or tie-down straps. Do not attempt to lift or secure the generator by holding onto any of its other components.
- Keep the unit level during transport to minimize the possibility of fuel leakage or, if possible, drain the fuel or run the engine until the fuel tank is empty before transport.
- The generator wheels are only intended for hand transport. The wheels are not suitable for towing the generator either on or off-road.
- Use the extendable handle for one-person, hand transport. To deploy the handle, push on the locking button and pull on the handle until it's fully extended. To stow it, push on the locking button and push on the handle until it's fully retracted. Only extend or retract the handle while the generator is OFF, stationary, and resting on a horizontal surface. Do not use the extendable handle to lift the generator entirely off the ground, tow it, or up-end it.

⚠ CAUTION



Fire hazard. Do not fully up-end the generator. Fuel or oil can leak and damage to the generator may occur.

MAINTENANCE

MAINTENANCE

MAINTENANCE SCHEDULE

Regular maintenance will improve performance and extend the service life of the generator. Follow the hourly or calendar intervals, whichever occurs first. More frequent service is required when operating in adverse conditions as noted below.

Before Each Use
Check engine oil
After First 25 Hours or First Month
Change engine oil
After 50 Hours or Every 6 Months
Change engine oil ¹ Clean air filter ²
After 100 Hours or Every 6 Months
Inspect/clean spark arrestor Inspect/clean spark plug Replace fuel filter ³ Inspect/adjust valve clearance ³
After 300 Hours or Every Year
Replace spark plug Replace air filter

- ¹ Change oil every month when operating under heavy load or in high temperatures.
- ² Clean more often under dirty or dusty conditions. Replace air filter if it cannot be adequately cleaned.
- ³ Recommend service to be performed by authorized Westinghouse service dealer.

MAINTENANCE REPLACEMENT PARTS

Description	Part Number
Foam air filter	5691
Oil drain plug crush washer	94007
Spark arrestor	6790
Battery	511019
Spark plug	97109 - F7RTC
Fuel filter	516401

ENGINE SERVICE COVER

Remove the engine service cover to access the air filter, carburetor, and spark plug. Remove the cover screws then pull the cover straight out with both hands to prevent damage to the grommet posts on the cover.

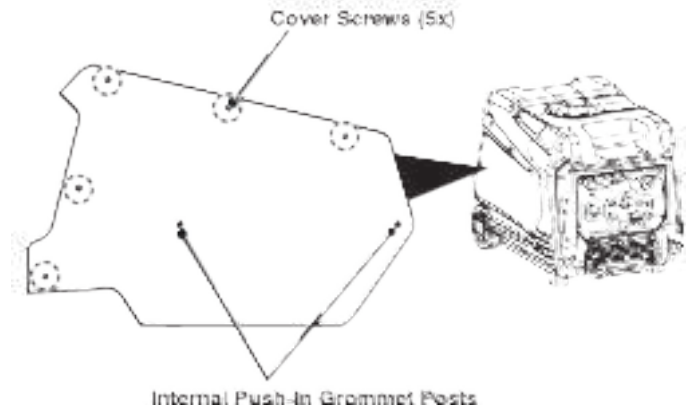

AIR FILTER MAINTENANCE

⚠ WARNING

Fire hazard. Never use gasoline or other flammable solvents to clean the air filter. Use only household detergent soap to clean the air filter.

The air filter must be cleaned after every 50 hours of use or six months (frequency should be increased if the generator is operated in a dusty environment).

1. Place the generator on a level surface and allow the engine to cool for several minutes.
2. Remove the engine service cover.
3. Turn the knobs on the air cleaner cover to the unlocked position. Tip the cover down to remove.

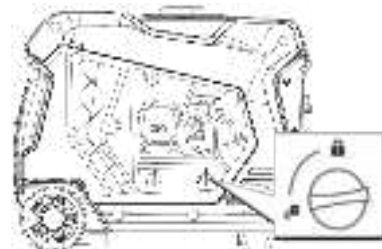

Note: The air filter element is oil soaked. Use an appropriate cleaning container.

MAINTENANCE

NOTICE

Avoid skin contact with engine oil. Wear protective clothing and equipment. Wash all exposed skin with soap and water.

- Remove the foam air filter from the air cleaner housing and wash it by submerging the element in a solution of household detergent soap and warm water. Slowly squeeze the foam to thoroughly clean.

NOTICE

DO NOT twist or tear the foam air filter element during cleaning or drying. Only apply slow but firm squeezing action.

- Rinse the air filter element by submerging it in fresh water and applying a slow squeezing action. Allow the filter to dry thoroughly.

NOTICE

Do not pollute. Follow the guidelines of the EPA or other governmental agencies for proper disposal of hazardous materials. Consult local authorities or reclamation facility.

- Dip the foam air filter in clean engine oil then squeeze out all excess oil. The engine will smoke when started if too much oil is left in the filter.
- Install the foam air filter in the housing and lock the air cleaner cover in place.
- Install the engine service panel.

ENGINE OIL LEVEL CHECK

CAUTION

Avoid skin contact with engine oil. Wear protective clothing and equipment. Wash all exposed skin with soap and water.

NOTICE

Always use the specified engine oil. Failure to use the specified engine oil can cause accelerated wear and/or shorten the life of the engine.

When using the generator under extreme, dirty, dusty conditions or in extremely hot weather, change the oil more frequently.

Ambient air temperature will affect engine oil performance. Change the type of engine oil used based on weather conditions.

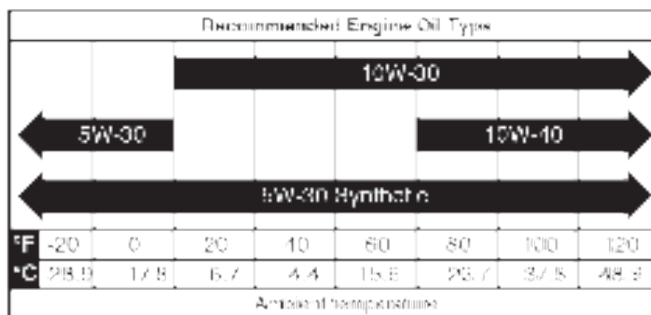

Check the engine oil level before each use or every 8 hours of operation.

- Place the generator on a level surface and allow the engine to cool for several minutes.
- Remove the oil access cover.
- With a damp rag, clean around the oil dipstick.
- Remove the oil dipstick and wipe the dipstick clean.

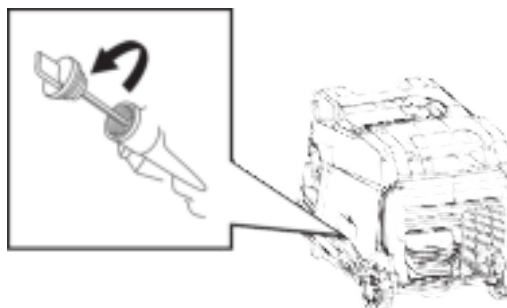

- Insert the dipstick into the filler neck without screwing it in. Remove the dipstick and verify that the oil level is within safe operating range.



- If low, add recommended engine oil incrementally and recheck until the level is between the L and H marks on the dipstick. DO NOT overfill. If over the full mark on dipstick, drain the oil to reduce oil level to the full mark on dipstick.
- Replace the oil dipstick and hand-tighten.
- Install the oil access cover.

ENGINE OIL CHANGE

⚠ WARNING

Accidental start-up. Remove the spark plug boot from the spark plug when working on the generator. Also remove the battery quick-connect plug from the battery.

When using the generator under extreme, dirty, dusty conditions or in extremely hot weather, change the oil more frequently. Change the oil while the engine is still warm from operation.

1. Place the generator on a level surface and allow the engine to cool for several minutes.
2. Remove the engine service cover. Disconnect the spark plug wire from the spark plug and place the wire where it cannot contact the spark plug.
3. Remove the oil access cover.
4. With a damp rag, clean around the oil dipstick. Remove the dipstick and wipe clean.
5. Remove the rubber plug under the oil drain bolt and place an oil pan (or suitable container) under the drain hole.
6. Using a 10mm wrench, remove the oil drain bolt and allow the oil to drain.

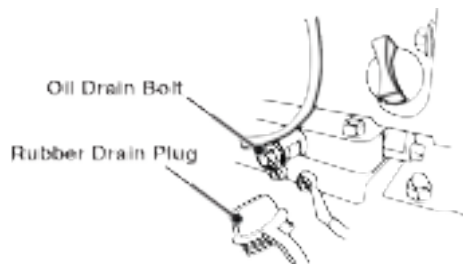

7. Install the oil drain plug and tighten securely. Install the rubber plug.

Note: A new oil drain plug crush washer is recommended at each oil change.

8. Slowly pour oil into the oil fill opening until the oil level is between the L and H marks on the dipstick. Stop frequently to check the oil level. DO NOT overfill.

Maximum oil capacity: 0.63 US qt (0.60 L)

9. Replace the dipstick and hand-tighten.
10. Connect the spark plug wire and install the engine service cover.

NOTICE

Do not pollute. Follow the guidelines of the EPA or other governmental agencies for proper disposal of hazardous materials. Consult local authorities or reclamation facility.

SPARK PLUG MAINTENANCE

Inspect and clean the spark plug after every 100 hours of use or six months. Replace the spark plug after 300 hours of use or every year.

NOTICE

Always use the Westinghouse OEM or compatible resistor-type spark plug. Use of a non-resistor spark plug can result in rough idling, misfire, or damage to generator components.

1. Place the generator on a level surface and allow the engine to cool.
2. Remove the engine service cover.
3. Remove the spark plug boot by firmly pulling the spark boot directly away from the engine.
4. Clean the area around the spark plug.
5. Remove the spark plug with the included spark plug socket wrench.

NOTICE

Never apply any side load or move the spark plug laterally when removing the spark plug.

6. Inspect the spark plug. Replace if electrodes are pitted, burned, or the insulator is cracked. Only use a recommended replacement plug.
7. Measure the spark plug electrode gap with a wire-type feeler gauge. If necessary, correct the gap by carefully bending the side electrode.

Spark plug gap: 0.024 - 0.032 in. (0.60 - 0.80 mm)

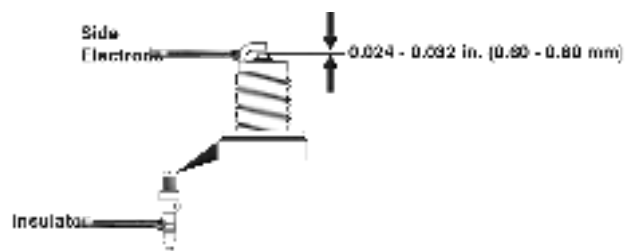

8. Carefully install the spark plug finger tight, then tighten as additional 3/8 to 1/2 turn with the spark plug wrench.
9. Install the spark plug boot and engine service cover.

MAINTENANCE

SPARK ARRESTOR SERVICE

Check and clean the spark arrestor after every 100 hours of use or six months. Failure to clean the spark arrestor will result in degraded engine performance.

1. Place the generator on a level surface and allow the muffler to cool before servicing the spark arrestor.
2. Remove the cover screws and the muffler cover. Use a screw driver to remove the spark arrestor.

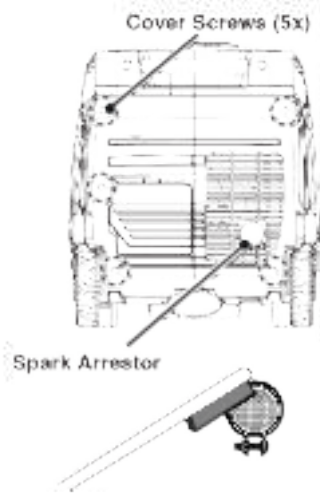

3. Carefully remove the carbon deposits from the spark arrestor screen with a wire brush. The spark arrestor must be free of breaks and tears. Replace the spark arrestor if damaged.
4. Reinstall the spark arrestor and muffler cover.

BATTERY MAINTENANCE

The battery shipped with the generator has been fully charged. A battery may lose some charge when not in use for prolonged periods of time. If the battery is unable to crank the engine, plug the included 12V charger into the battery charging port on the control panel.

Note: If the generator is not run, charge the battery overnight once a month.

⚠ CAUTION

The supplied battery charger is not a trickle charger and is not intended for continuous use. Do not use the battery charger for more than 8 hours (overnight) to prevent overcharging the battery.

Note: Once started, the generator will charge the battery after 30–60 minutes of use. If you do not regularly run the generator, charge the battery overnight once a month to keep it ready for use. Charge the battery in a dry location.

1. Plug the charger into the battery charging port on the control panel. Plug the wall receptacle end of the battery charger into a 120 Volt AC wall outlet.
2. Unplug the battery charger from wall outlet and control panel jack after 8 hours of charging.

BATTERY REPLACEMENT

⚠ WARNING

Burn hazard. The battery contains sulfuric acid (electrolyte) which is highly corrosive and poisonous. Wear protective clothing and eye protection when working near the battery. Keep children away from the battery.

⚠ CAUTION

Battery posts, terminals contain lead and lead compounds. Wash hands after handling.

1. Remove the battery access cover.
2. Remove the quick-connect plug and remove the battery strap. Remove the battery from the unit.
3. Disconnect the quick-disconnect cable leads from the battery.
4. On the replacement battery, connect the white (-) quick-connect cable to the battery negative terminal. Slide the rubber boot over the connection hardware.
5. Connect the red (+) quick-connect cable to the battery positive terminal. Slide the rubber boot over the connection hardware.
6. Lift the battery strap and install the battery into the generator. Thread the battery strap under the quick-connect cables and secure it on the mounting base.
7. Connect the quick-connect plug and install the battery access cover.

NOTICE

Dispose of the used battery properly according to the guidelines established by your local or state government.

STORAGE

Proper storage preparation is required for trouble-free operation and generator longevity.

NOTICE

Gasoline stored for as little as 30 days can deteriorate, causing gum, varnish, and corrosive buildup in fuel lines, fuel passages and the engine. This corrosive buildup restricts the flow of fuel, which can prevent the engine from starting after a prolonged storage period. The use of fuel stabilizer significantly increases the storage life of gasoline. Full-time use of fuel stabilizer is recommended. Follow the manufacturer's instructions for use.

STORAGE TIME	RECOMMENDED PROCEDURE
Less than 1 month	No service required.
2 to 6 months	Fill with fresh gasoline and add gasoline stabilizer. Drain the carburetor float bowl.
6 months or longer	Drain the fuel tank and carburetor float bowl.

SHORT TERM STORAGE

- Allow the generator to cool a minimum of 30 minutes before storage.
- Replace all protective covers on the generator control panel.
- Wipe the generator with a moist cloth. Clean any debris from the air inlets under the control panel and muffler cooling vents.
- Store the generator in a well-ventilated, dry location away from sparks, open flames, pilot lights, heat, and other sources of ignition such as areas with a spark-producing electric motor or where power tools are operated.
- Do not store the generator or gasoline near furnaces, water heaters, or any other appliances that produce heat or have automatic ignitions.
- With the engine and exhaust system cool and all surfaces dry, cover the generator to keep out dust. Do not use a plastic sheet as a dust cover. Non-porous materials trap moisture and promote rust and corrosion.

LONG TERM STORAGE

Even properly stabilized fuel can leave residue and cause corrosion if left long term. If storing the generator for two to six months, drain the float bowl to prevent gum and varnish buildup in the carburetor.

DRAINING THE FLOAT BOWL

1. Remove the engine service cover.
2. Locate the drain hose extending from the bottom of the carburetor float bowl.

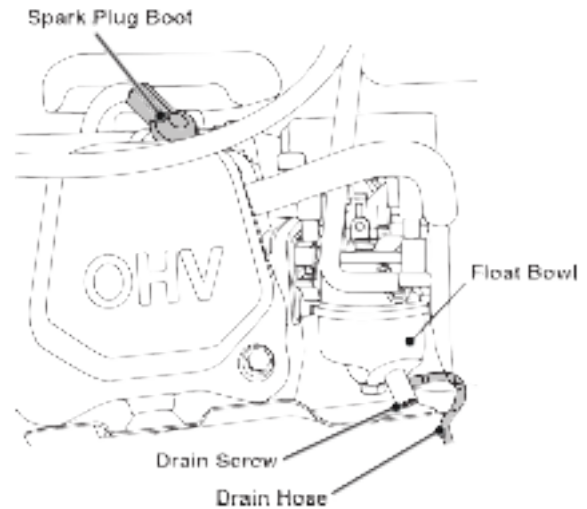

3. Place the loose end of the hose outside the generator into an approved gasoline container to catch the drained fuel.
4. Loosen the float bowl drain screw and allow the fuel to drain. Tighten the float bowl drain screw.
5. Route the drain hose between the air cleaner housing and the engine service cover. Install the engine service cover.

DRAINING THE FUEL TANK

If storing the generator for longer than six months, drain the fuel tank to prevent fuel separation, deterioration, and deposits in the fuel system.

1. Unscrew the fuel tank cap. Remove the fuel screen filter by slightly compressing it while removing it from the tank.
2. Using a commercially available gasoline hand pump (not included), siphon the gasoline from the fuel tank into an approved gasoline container. DO NOT use an electric pump.
3. Reinstall the fuel screen filter and the fuel tank cap.
4. Start the generator and allow it to run until the generator engine stops.
5. Push the battery switch to the OFF position.
6. Disconnect the battery quick-connect plug.
7. Remove the spark plug.

MAINTENANCE

8. Put a teaspoon of engine oil into the cylinder and pull the recoil handle until resistance is felt. At this position the piston is coming up on its compression stroke and both valves are closed. Storing the engine in this position will help prevent internal corrosion. Return the recoil handle gently.
9. Reinstall the spark plug. Leave the spark plug boot disconnected to prevent accidental starting.
10. Install the engine service cover.

VALVE CLEARANCE

NOTICE

Checking and adjusting valve clearance must be done when the engine is cold.

1. Remove the rocker arm cover and carefully remove the gasket. If the gasket is torn or damaged, it must be replaced.
2. Remove the spark plug so the engine can be rotated more easily.
3. Rotate the engine to top dead center (TDC) by pulling the recoil handle slowly. Looking through the spark plug hole, the piston should be at the top (both valves are closed).
4. Both the rocker arms should be loose at TDC on the compression stroke. If they are not, rotate the engine 360°.
5. Insert a feeler gauge between the rocker arm and the valve stem to measure valve clearance.

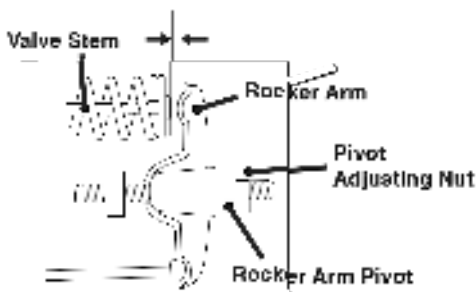

	Intake Valve	Exhaust Valve
Valve Clearance	0.0031 – 0.0047 in (0.08 – 0.12 mm)	0.0051 – 0.0067 in (0.13 – 0.17 mm)
Torque	8-12 N·m	8-12 N·m

6. If an adjustment is necessary, hold the rocker arm pivot and loosen the pivot adjusting nut.
7. Turn the rocker arm pivot to obtain the specified clearance. Hold the rocker arm pivot and re-tighten the pivot adjusting nut to the specified torque.

Torque: 106 inch-pound (12 N·m)

8. Perform this procedure for the other valve.
9. Install the gasket, rocker arm cover, and spark plug.

MANUAL CHOKE OPERATION

If the battery is dead or disconnected, you may need to set the choke by hand for proper operation.

1. Remove the engine service cover.
2. Locate the small black choke lever on top of the carburetor.

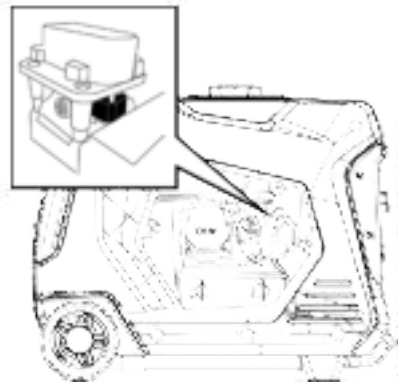

3. To close the choke for cold starting: Use a screwdriver to push the black lever toward the front of the generator.

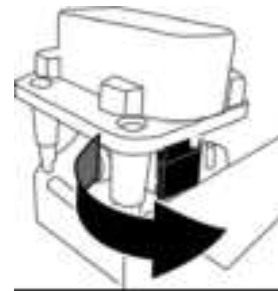

4. Start the generator. The start-up sequence should automatically open the choke. If the choke does not open automatically, push the choke manually to open it.

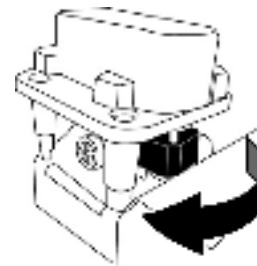

NOTICE

Certain ambient temperatures and environments may require you to close the choke halfway for a successful start.

TROUBLESHOOTING

TROUBLESHOOTING

PROBLEM	POSSIBLE CAUSE	CORRECTION
Engine will not start	Battery switch in the OFF position.	Turn battery switch to the ON position.
	Out of fuel.	Refuel.
	Bad fuel, generator stored without treating or draining gasoline, or refueled with bad gasoline.	Drain the fuel tank. Refuel with fresh gasoline.
	Dirty air filter.	Clean the air filter.
	Low engine oil level stopped generator.	If low oil LED illuminated, turn battery switch to the OFF position. Add engine oil.
	Spark plug wet with fuel (flooded engine).	Wait five minutes. Turn battery switch to the OFF position. Pull recoil handle rapidly several times. If the generator does not start, remove spark plug and dry.
	Spark plug faulty, fouled, or improperly gapped.	Gap or replace the spark plug. Reinstall.
	Fuel filter restricted, fuel system malfunction, fuel pump failure, ignition malfunction, valves stuck, etc.	Contact Westinghouse customer service toll-free at 1 (855) 944-3571.
	Battery drained.	Use the recoil handle to start the generator. Charge the battery.
	Choke partially open or closed due to weak or disconnected battery.	Manually set the choke. See Maintenance section.
Engine starts, then shuts down	Out of fuel.	Refuel.
	Incorrect engine oil level.	Check engine oil level.
	Dirty air filter.	Clean the air filter.
	Contaminated fuel.	Drain the fuel tank. Refuel with fresh gasoline.
	Defective low oil level switch.	Contact Westinghouse customer service toll-free at 1 (855) 944-3571.
Engine lacks power	Air filter restricted.	Clean or replace air filter.
	Bad fuel, generator stored without treating or draining gasoline, or refueled with bad gasoline.	Drain the fuel tank. Refuel with fresh gasoline.
	Fuel filter restricted, fuel system malfunction, fuel pump failure, ignition malfunction, valves stuck, etc.	Contact Westinghouse customer service toll-free at 1 (855) 944-3571.
Engine runs rough or bogs when load applied	Dirty air filter.	Clean the air filter.
	Generator overloaded.	Unplug some devices.
	Faulty power tool or appliance.	Replace or repair tool or appliance. Stop and restart the engine.
	Fuel filter restricted, fuel system malfunction, fuel pump failure, ignition malfunction, valves stuck, etc.	Contact Westinghouse customer service toll-free at 1 (855) 944-3571.
No power at AC receptacles	OUTPUT READY LED is OFF and OVERLOAD LED is ON.	Check AC load. Stop and restart engine. Check the air inlet. Stop and restart the engine.
	AC circuit breaker/s tripped.	Check AC loads and reset circuit breaker/s.
	Faulty power tool or appliance.	Replace or repair tool or appliance. Stop and restart the engine.
	Faulty generator.	Contact Westinghouse customer service toll-free at 1 (855) 944-3571.

EXPLODED VIEWS

EXPLODED VIEWS AND PARTS LISTS

ENGINE EXPLODED VIEW

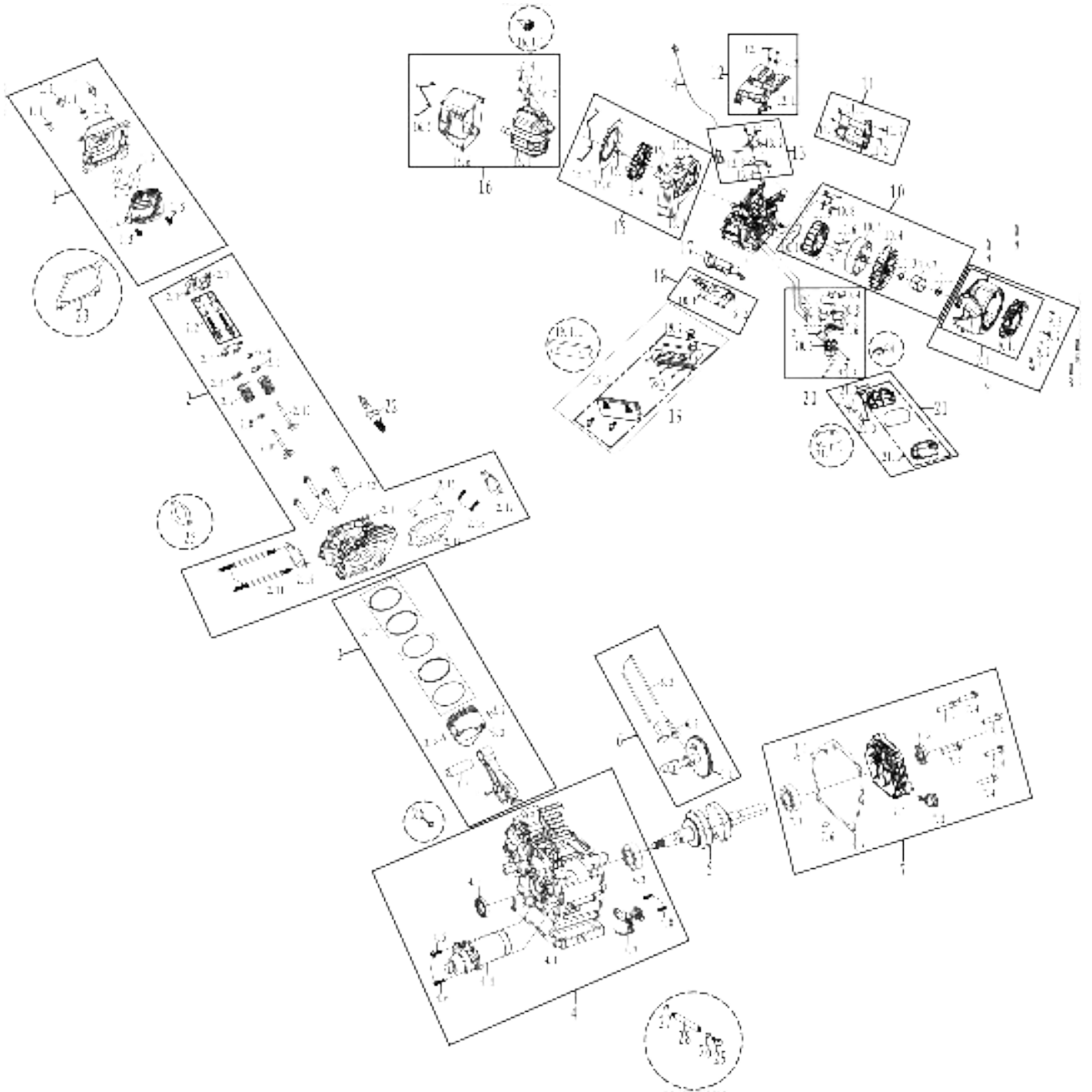

EXPLODED VIEWS

ENGINE PARTS LIST

NO.	PART#	DESCRIPTION
1		CYLINDER HEAD COVER ASSEMBLY
1.1	91325	BOLT M6X12
1.2	241115	CYLINDER HEAD COVER
1.3	339915	POLYURETHANE SCREEN
1.4	241116	CYLINDER HEAD INNER COVER
1.5	91322	BOLT M5*12
2		CYLINDER HEAD ASSEMBLY
2.1	242101	ROCKING ARM
2.2	91818	ROCKING ARM TIGHTENING BOLT ASSEMBLY
2.3	242202	VALVE RETAINER ASSEMBLY
2.4	241804	TOP CAP
2.5	241801	INTAKE VALVE SPRING SEAT
2.6	241802	EXHAUST VALVE SPRING SEAT
2.7	246001	VALVE SPRING
2.8	241806	INTAKE VALVE SPRING LOWER SEAT
2.9	241704	INTAKE VALVE
2.10	245904	EXHAUST VALVE
2.11	91029	AIR INLET STUD BOLT
2.12	91359	BOLT M8X60
2.13	241021	CYLINDER HEAD
2.14	96058	CYLINDER HEAD GASKET
2.15	240905	CYLINDER HEAD LOCATING PIN
2.16	91007	AIR EXHAUST STUD BOLT
2.17	96055	EXHAUST SEAL WASHER
2.18	96182	AIR INTAKE GASKET
3		PISTON & PISTON RING ASSEMBLY
3.1	241607	PISTON RING ASSEMBLY
3.2	241301	PISTON PIN RING
3.3	241211	PISTON
3.4	245503	PISTON PIN
3.5	331500	CONNECTING ROD ASSEMBLY
4		CRANKCASE ASSEMBLY
4.1	330202	CRANKCASE
4.2	93010	BEARING
4.3	93507	CRANKCASE OIL SEAL
4.4	97447	STARTING MOTOR ASSEMBLY
4.5	91333	BOLT M6*28
4.6	91334	BOLT M6X30
4.7	245113	OIL SENSOR
4.8	91329	BOLT M6X16
5	240364	CRANKSHAFT ASSEMBLY
6		CAMSHAFT ASSEMBLY
6.1	332003	CAMSHAFT ASSEMBLY
6.2	246103	VALVE LIFTER
6.3	241901	PUSH ROD
7		CRANKCASE COVER ASSEMBLY

NO.	PART#	DESCRIPTION
7.1	240116	CRANKCASE COVER
7.2	245601-295	DIPSTICK ASSEMBLY
7.3	93507	CRANKCASE OIL SEAL
7.4	91347	BOLT M8X30
7.5	96041	CRANKCASE SEAL WASHER
7.6	240904	CRANKCASE LOCATING PIN
7.7	93010	BEARING
8	599601	METAL CLIP
9		RECOIL STARTER ASSEMBLY
9.1	330501	RECOIL STARTER
9.1.1	5324	START PULL PLATE
9.2	91329	BOLT M6X16
10		IMPELLER ASSEMBLY
10.1	91864	BOLT
10.2	334501	STARTER PULLEY
10.3	90003	NUT M14
10.4	334601	IMPELLER
10.5	500191	ROTOR
10.6	91400	BOLT M6X60
10.7	503410	STATOR
10.8	91329	BOLT M6X16
10.9	339902	TRIGGER
10.10	240904	CRANKCASE LOCATING PIN
11		WIND LEAD COVER ASSEMBLY
11.1	330503	WIND LEAD COVER
11.2	91325	BOLT M6X12
12		UPPER WIND SHIELD ASSEMBLY
12.1	330502	UPPER WIND SHIELD
12.2	249914	CRIMPING BLOCK
12.3	91325	BOLT M6X12
13		IGNITION COIL ASSEMBLY
13.1	91333	BOLT M6*28
13.2	339909	IGNITION COIL
13.3	339903	IGNITION COIL MOUNTING BRACKET
13.4	90016	NUT M6
14	335803	TEMPERATURE SENSOR
15		CENTRIFUGAL FAN HOUSING ASSEMBLY
15.1	244306	CENTRIFUGAL FAN HOUSING.
15.2	244304	CENTRIFUGAL HOOD PLUG
15.3	91343	BOLT M8*16
15.4	244606	IMPELLER
15.5	91419	BOLT M8*1*25
15.6	334302	CENTRIFUGAL FAN COVER
15.7	91330	BOLT M6X20
16		EXHAUST MUFFLER ASSEMBLY
16.1	243782	MUFFLER

EXPLODED VIEWS

ENGINE PARTS LIST CONTINUED

NO.	PART#	DESCRIPTION
16.1.1	6790	SPARK ARRESTER
16.2	94216	FLAT WASHER
16.3	94206	SPRING WASHER
16.4	90011	NUT M8
16.5	91330	BOLT M6X20
16.6	500057	MUFFLER COVER
17	240511	SHIELD
18		BRACKET ASSEMBLY
18.1	91330	BOLT M6X20
18.2	249917	BRACKET
19		AIR FILTER ASSEMBLY
19.1	332901	AIR FILTER
19.1.1	5691	FILTER
19.2	95918	CONNECTING PIPE
20		CARBURETOR ASSEMBLY
20.1	332301	CARBURETOR CONNECTION BLOCK
20.2	92219	SCREW M4*20
20.3	90016	NUT M6
20.4	249934	WATERPROOF COVER
20.5	332801	CARBURETOR ASSEMBLY
20.6	249925	STEPPER MOTOR BRACKET
20.7	92055	SCREW M4X25
20.8	249949	STEPPER MOTOR
20.9	249950	STEPPER MOTOR
20.10	92240	CROSSING SCREW M4X6
21		RESONANT CAVITY ASSEMBLY
21.1	337001	RESONANT CAVITY
21.1.1	5697	FOAM FILTER
21.2	249919	PLUG
21.3	95602	BREATHER TUBE
21.4	94407	FUEL LINE CLAMP
22	97109	SPARK PLUG
23	96200	CYLINDER HEAD COVER SEAL WASHER
24	94226	STEEL WASHER
25	96051	CARBURETOR GASKET
26	94007	OIL DRAIN BOLT WASHER
27	94035	OIL DRAIN BOLT WASHER
28	91831	OIL DRAIN SOLENOID
29	91816	OIL DRAIN BOLT

EXPLODED VIEWS

GENERATOR EXPLODED VIEW

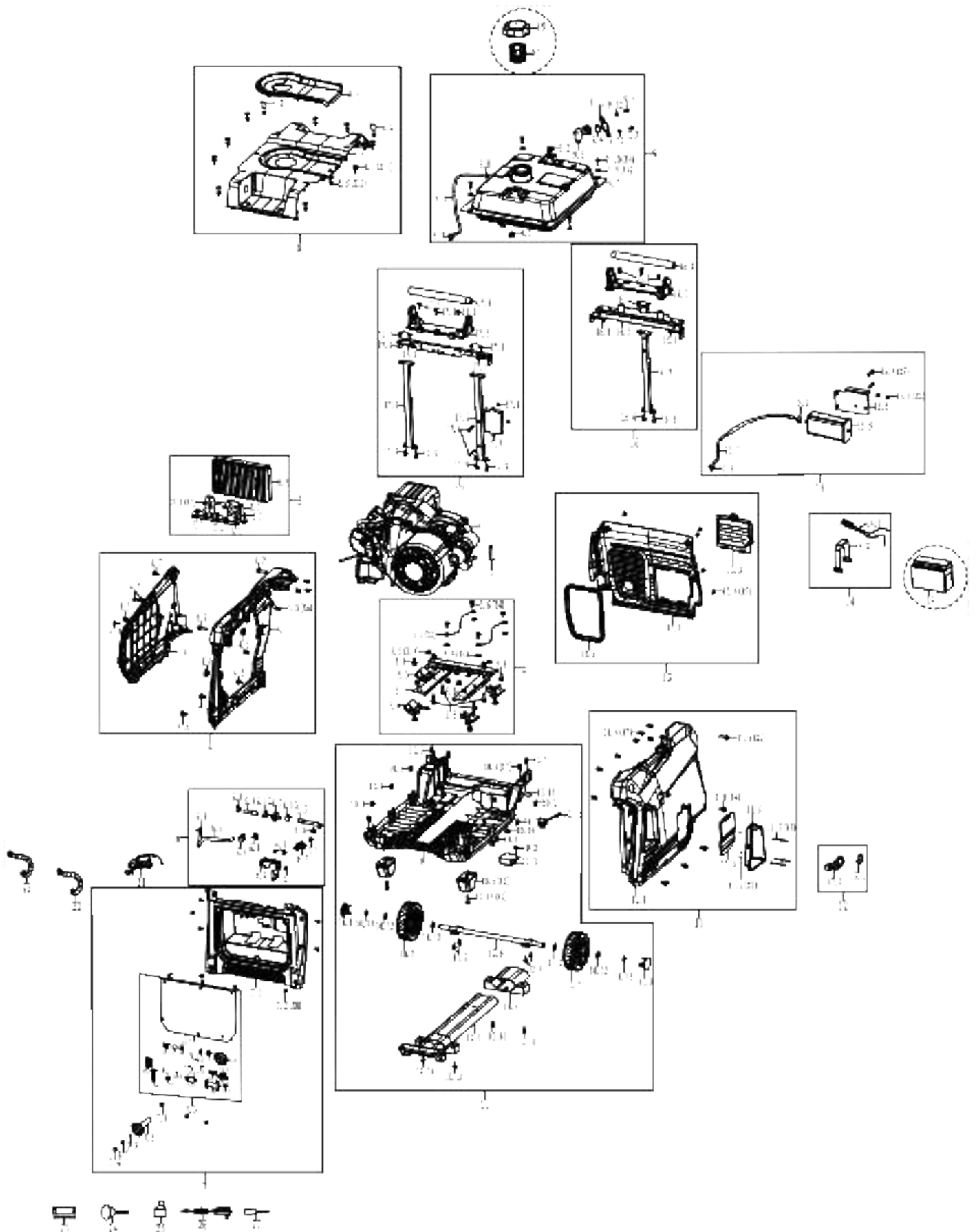

EXPLODED VIEWS

GENERATOR PARTS LIST

NO.	PART#	DESCRIPTION
1	110022 530064	ENGINE ASSEMBLY
2	599601	METAL CLIP
3		INVETER MODULE ASSEMBLY
3.1	91325	BOLT M6X12
3.2	503147	INVETER
3.3	503013	BRACKET
3.4	91322	BOLT M5x12
4		LEFT FRAME ASSEMBLY
4.1	503005-221	LEFT FRAME
4.2	91345	BOLT M8X20
4.3	500060	LOCK CLIP M6
4.4	503039- 221A	LEFT PANEL
4.5	92097	HEX FLANGE SCREW M6X20
4.6	500007	FUEL TANK ISOLATION PAD A
4.7	92079	STOP BOLT M6X16
5		BRACKET ASSEMBLY
5.1	503001	BRACKET
5.2	503002	BRACKET
5.3	503003	BRACKET
5.4	503004	ISOLATION PAD
5.5	90044	NUT M8
5.6	91325	BOLT M6X12
5.7	500044	SHORT WIRE
5.8	91348	BOLT M8X35
5.9	94003	TOOTH WASHER
6		BRACKET ASSEMBLY
6.1	91325	BOLT M6X12
6.2	503017	BRACKET
6.3	503018L	FUEL LINE CLAMP
6.4	503019L	FUEL LINE CLAMP
6.5	503020L	FUEL LINE CLAMP
6.6	503044	CLIP
6.7	503062	FUEL SWITCH
6.8	503034	FUEL LINE CLAMP
6.9	516401	FUEL FILTER
6.10	94408	FUEL LINE CLAMP
7		CONTROL PANEL ASSEMBLY
7.1	503016	PANEL REAR COVER
7.2	92078	CROSS RECESSED PAN HEAD BOLT M6X16
7.3	503061	CONTROL PANEL ASSEMBLY
7.3.1	6500	ROCKER SWITCH
7.3.2	9022	ONE PUSH BUTTON SWITCH
7.3.3	9032	ECO SWITCH
7.3.4	9079	WATERPROOF CAP

NO.	PART#	DESCRIPTION
7.3.5	6441-31	31A THERMAL PROTECTOR
7.3.6	6404	WATERPROOF CAP
7.3.7	9025	CHARGING SOCKET
7.3.8	6441-30	30A THERMAL PROTECTOR
7.3.9	6404	WATERPROOF CAP
7.3.10	9089	START INDICATOR
7.3.11	6441-20	20A THERMAL PROTECTOR
7.3.12	6404	WATERPROOF CAP
7.3.13	97537	IGNITOR
7.3.14	503310	KNOB PLUG
7.3.15	9141	USB
7.3.16	503108	USB DUST COVER
7.3.17	9021	VOLTAGE RESET BUTTON
7.3.18	9110	LED
7.3.19	9193	PARRALLEL PORTS
7.3.20	9122	WATERPROOF CAP
7.3.21	6032	5-20R RECEPTACLE
7.3.22	9194	DUST COVER
7.3.23	6015	RV SOKET
7.3.24	6849	DUST COVER
7.3.25	9132	GROUNDING BOLT
7.3.26	9016	PANEL BODY
7.4	91825	BOLT M5X12
7.5	503024	KNOB
7.6	500068	HANDLE BAFFLE PLUG
7.7	92032	SCREW M4*16
7.8	94325	FLAT WASHER
8		TOP COVER ASSEMBLY
8.1	500068	HANDLE BAFFLE PLUG
8.2	503025	PLUG
8.3	503029	OIL CHANNEL
8.4	503038-221	TOP COVER
8.5	92078	CROSS RECESSED PAN HEAD BOLT M6X16
9		FUEL TANK ASSEMBLY
9.1	503068L	FUEL TANK ASSEMBLY
9.2	500008	FUEL TANK ISOLATION PAD B
9.3	91322	BOLT M5x12
9.4	500252	SEALING RING
9.5	95127	CARBON CANISTER AND FUEL TANK CONNECTING PIPE
9.6	500247	GASOLINE SENSOR
9.7	94405	FUEL LINE CLAMP
9.8	94403	FUEL LINE CLAMP
9.9	96801	FUEL TANK WASHER
9.11	500244	PRESSURE PLATE
9.12	500324	SEALING WASHER

EXPLODED VIEWS

GENERATOR PARTS LIST CONTINUED

NO.	PART#	DESCRIPTION
10	100200006	BASEBOARD ASSEMBLY
10.1	90027	SQUARE NUT
10.2	91325	BOLT M6X12
10.3	503048	DC VOLTAGE REGULATOR
10.4	500060	LOCK CLIP M6
10.5	503026	ISOLATION PAD
10.6	503023	AXLE
10.7	503031	WHEEL
10.8	503032	WHEEL COVER
10.9	503033	PULL ROD HOLDER
10.10	503035	PULL ROD
10.11	503045	BOTTOM PLATE
10.12	94022	STEEL WASHER
10.13	500321	AXLE WILD CARD
10.14	503053	LIMIT BLOCK
10.15	503052	BASE OIL COVER
10.16	91334	BOLT M6X30
11		RIGHT FRAME ASSEMBLY
11.1	503021-221A	RIGHT FRAME
11.2	91345	BOLT M8X20
11.3	503022-221	OBSERVATION COVER
11.4	500060	LOCK CLIP M6
11.5	503067	BLIND RIVET
11.6	503036-052	HANDLE DECORATIVE BOARD
11.7	94249	FLAT WASHER
11.8	92097	HEX FLANGE SCREW M6X20
12		RECOIL HANDLE ASSEMBLY
12.1	500017-231	HANDLE COVER
12.2	500018	HANDLE
13		MUFFLER BAFFLE ASSEMBLY
13.1	503027	MUFFLER BAFFLE
13.2	500108	MUFFLER EXHAUST SEALING STRIP
13.3	503040	COVER
13.4	92078	CROSS RECESSED PAN HEAD BOLT M6X16
14		BATTERY ASSEMBLY
14.1	503165	BATTERY CABLE
14.2	599606	BATTERY TIE
15		CARBON CANISTER ASSEMBLY
15.1	91325	BOLT M6X12
15.2	94405	FUEL LINE CLAMP
15.3	94403	FUEL LINE CLAMP
15.4	91334	BOLT M6X30
15.5	543301L	CARBON CANISTER ASSEMBLY
15.6	503043	BRACKET
15.7	95016	CARBON CANISTER AND AIR FILTER CONNECTING PIPE

NO.	PART#	DESCRIPTION
16		BRACKET ASSEMBLY
16.1	91325	BOLT M6X12
16.2	503006	UPRIGHT
16.3	503008	BRACKET
16.4	503009	HANDLE
16.5	503042	BRACKET
16.6	91330	BOLT M6X20
17		BRACKET ASSEMBLY
17.1	91325	BOLT M6X12
17.2	503007	UPRIGHT
17.3	503008	BRACKET
17.4	503009	HANDLE
17.5	503011	BRACKET
17.6	91335	BOLT M6X35
17.7	503047	CONTROL MODULE
17.8	90010	NUT M6
17.9	91330	BOLT M6X20
18	511019	BATTERY
19	503028	FUEL TANK CAP
20	518801	FILTER
21	503388	WIRING HARNESS
22	503082	BELLOW
23	99011	SPARK PLUG WRENCH
24	500942	FUNNEL
25	99629	OIL BOTTLE
26	511043	CHARGER
27	99506	SCREWDRIVER

SCHEMATICS

SCHEMATICS

