

DIGITAL PANEL METERS

Model PD690 Universal Process Meter

Instruction Manual

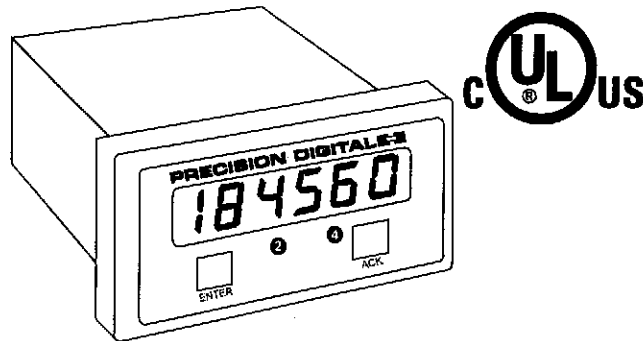

- Easy **Single Button Scaling (SBS)**
- 4-20 mA, 0-5 V, or 0-10 V Field Selectable Inputs
- 24 V Transmitter Power Supply Standard
- Stand Alone Scaling
- Steady, Accurate Display to $\pm 199,990$
- 11 Point Linearization
- Square Root Extraction with Low-flow Cutoff
- 4½ Digit + Extra Zero
- Type 4X, NEMA 4X Front Panel
- 2 or 4 Relays + 4-20 mA Output Options
- Green Display Available
- Lockout Feature
- Non-volatile Memory, No Battery Needed.

PRECISION DIGITAL CORPORATION
19 Strathmore Road • Natick MA 01760 USA
Tel 800-610-5239 • Fax 508-655-8990



| | |
|--|----|
| INTRODUCTION | 4 |
| Typical Applications | 4 |
| Ordering Information | 4 |
| Safety Notice | 5 |
| Specifications | 6 |
| Basic Meter..... | 6 |
| Options | 7 |
| Display Messages and Functions | 9 |
| SETUP AND PROGRAMMING | 10 |
| Power, Signal, External Functions & Options Connections | 10 |
| Overview | 11 |
| Wiring Instructions..... | 11 |
| AC Powered Units (Power, Signal, External Functions) | 12 |
| DC Powered Units (Power, Signal, External Functions) | 14 |
| Relays & 4-20 mA Output | 15 |
| 4-20 mA Output | 16 |
| Programming | 17 |
| Overview..... | 17 |
| Single Button Scaling (SBS) | 17 |
| Two-point External Calibration Flow Chart | 18 |
| Five Basic Digit/Display-setting Instructions | 19 |
| Basic Meter Programming | 19 |
| Overview | 19 |
| Select Input Signal | 20 |
| Initial Calibration with External Source (If Needed) | 20 |
| Select Calibration Method | 21 |
| Scale or Calibrate the Meter | 21 |
| Select Decimal Point (dECPt) | 21 |
| Select Linear Input (L or S) | 21 |
| Select Number Of Calibration Points (no. Pt5) | 21 |
| General Calibration/Scaling Instructions | 22 |
| Scale Using Internal Calibration (I-CAL)..... | 22 |
| Calibrate Using an External Calibrator (E-CAL) | 23 |
| Calibration Error (Error) | 23 |
| Programming Confirmation..... | 23 |

| | |
|--|----|
| Select Square Root Extraction (L or S) | 24 |
| Program Low-flow Cutoff (Cutoff) | 24 |
| Round Horizontal Tank Calibration Table..... | 25 |
| Isolated 4-20 mA Output Option Programming (outPut) | 26 |
| Setting 4 mA Output Value..... | 26 |
| Setting 20 mA Output Value..... | 26 |
| Programming Confirmation..... | 26 |
| Alarm Programming | 27 |
| Overview | 27 |
| Setting Alarm Set & Reset Points (ALR-S) | 27 |
| Programming Confirmation | 28 |
| Alarm Operation..... | 28 |
| Set Relays for Fail-safe Operation | 28 |
| Alarm Acknowledgment | 29 |
| Automatic & Manual Reset Programming..... | 29 |
| Lockout Jumper | 30 |
| SWITCHING INDUCTIVE LOADS | 30 |
| AC & DC Loads | 30 |
| Low Voltage DC Loads | 31 |
| RC Networks Available from Precision Digital | 31 |
| OPTION CARD INSTALLATION | 32 |
| MOUNTING DIMENSIONS | 33 |
| PROGRAMMED PARAMETER SETTINGS | 34 |
| OTHER PRECISION DIGITAL PRODUCTS | 35 |
| HOW TO CONTACT PRECISION DIGITAL | 36 |

INTRODUCTION

This meter is a high performance, easy to use, industrial-grade micro-processor-based digital process meter. It accepts all the standard process signals: 4-20 mA, 1-5V, 0-5V and 0-10V and displays these signals in engineering units on a 4½ digit display. The display includes an extra zero, which may be used to handle numbers up to 199,990. The meter also provides 24 VDC to power the transmitter. Options include 2 or 4 relays and an Isolated 4-20 mA Transmitter Output.

Typical Applications**Level:**

Sump Pump Control
Water Tank Level
Round Horizontal Tank Volume Measurement
Well Draw-down
Lift Station Control

Flow:

Square Root Extraction from a DP Transmitter

Pressure:

Compound Pressure
High Pressure Alarms

Ordering Information

| 115 VAC Model | 230 VAC Model | 24 VDC Model | Description | Option Card* |
|---------------|---------------|--------------|---------------------------|--------------|
| PD690-3-N | PD690-4-N | PD690-2-N | No Options | |
| PD690-3-14 | PD690-4-14 | PD690-2-14 | 2 Relays | PD174 |
| PD690-3-15 | PD690-4-15 | PD690-2-15 | 4-20mA Out | PD175 |
| PD690-3-16 | PD690-4-16 | PD690-2-16 | 2 Relays + 4-20 mA Out | PD176 |
| PD690-3-17 | PD690-4-17 | PD690-2-17 | 4 Relays | PD177 |
| PD690-3-18 | PD690-4-18 | PD690-2-18 | 4 Relays + 4-20 mA Out | PD178 |

Add (-G) to part number to call out meters with green display:

Example: PD690-3G-14

*Part numbers for Option Cards when purchased separately

Safety Notice

CAUTION: Read complete instructions prior to installation and operation of the Meter.



WARNING: Risk of electric shock.



Observe all safety regulations. Electrical wiring should be performed in accordance with all applicable national, state and local codes to prevent damage to the Meter and ensure personnel safety.

Do not use this meter to directly drive heavy equipment such as pumps, motors, valves, etc.



It is recommended to use this meter in a fail-safe system that accommodates the possibility of meter failure or power failure.

WARNING

Hazardous voltages exist within enclosure. Installation and service should be performed only by trained service personnel.

AVERTISSEMENT

Les pièces à l'intérieur du boîtier portent des tensions dangereuses. Seules des personnes qualifiées et bien entraînées devraient entreprendre l'étalonnage et la maintenance.

DISCLAIMER

The information contained in this document is subject to change without notice. Precision Digital makes no representations or warranties with respect to the contents hereof, and specifically disclaims any implied warranties of merchantability or fitness for a particular purpose.

SPECIFICATIONS

Except where noted all specifications apply to operation at +25°C

Basic Meter

| INPUTS | Field selectable: 4-20 mA, 0-20 mA, 0-5 V, 1-5 V, 0-10 V. | | | | | | | | |
|-------------------------------|---|--------------|---|-------|--------|--------|--------|---------|---------|
| DISPLAY | Bright, large, 0.56" (14.2mm) high efficiency red or green LEDs. 4½ digits + extra zero may be switched on to display +/- 19,999(0). Leading zeros blanked. | | | | | | | | |
| DECIMAL POINT | Decimal point may be placed in any of the following positions. 1.9999, 19.999, 199.99, 1999.9, 19999 or 199990 with extra zero. | | | | | | | | |
| CALIBRATION RANGE | 4 mA (1 V) input may be set anywhere in range of the meter. 20 mA (5 V) may be set anywhere in range of the meter above or below 4 mA input. An Error message will appear if Input 1 signal and Input 2 signal are too close together. <table border="1"> <thead> <tr> <th>Input Range:</th> <th>Minimum Difference Between Input 1 & Input 2:</th> </tr> </thead> <tbody> <tr> <td>0-5 V</td> <td>0.16 V</td> </tr> <tr> <td>0-10 V</td> <td>0.32 V</td> </tr> <tr> <td>4-20 mA</td> <td>1.60 mA</td> </tr> </tbody> </table> | Input Range: | Minimum Difference Between Input 1 & Input 2: | 0-5 V | 0.16 V | 0-10 V | 0.32 V | 4-20 mA | 1.60 mA |
| Input Range: | Minimum Difference Between Input 1 & Input 2: | | | | | | | | |
| 0-5 V | 0.16 V | | | | | | | | |
| 0-10 V | 0.32 V | | | | | | | | |
| 4-20 mA | 1.60 mA | | | | | | | | |
| INPUT IMPEDANCE | Voltage ranges, greater than 300 Kohms; current ranges, 100 ohms. | | | | | | | | |
| LOOP POWER | (AC Meters only), Isolated 24 VDC ± 5% @ 20 mA regulated. Maximum loop resistance is 1200 ohms. Available for either signal input or 4-20 mA output, but not both. | | | | | | | | |
| HOLD READING | Connect terminals H and CM | | | | | | | | |
| ACCURACY | ±0.05% of calibrated span, ±1 count. | | | | | | | | |
| SQUARE ROOT EXTRACTION | ±0.1% F.S. ± 1 count from 10-100% of flow. | | | | | | | | |
| LOW FLOW CUTOFF | Any input below the Low-flow Cutoff point will result in a display of zero. May be set from 1 count to 100% of full scale, user selectable. | | | | | | | | |

| | | |
|--|---|--|
| 11 POINT LINEARIZATION | Input Range 4-20 mA 0-5 V 0-10 V | Minimum Span Between Inputs (1.6 mA / (Number of points -1)) (0.16 V / (Number of points -1)) (0.32 V / (Number of points -1)) |
| <i>e.g. Minimum span for an 11-point, 4-20 mA calibration is 0.16 mA between inputs.</i> | | |
| ALARM POINTS | Four, any combination of high or low alarms. | |
| ALARM POINT DEADBAND | 0-100% of full scale, user selectable. | |
| ALARM STATUS INDICATION | Front panel LED. | |
| LOCKOUT | Jumper J3 restricts modification of calibration values. | |
| NON-VOLATILE MEMORY | All programming values are stored in non-volatile memory for a minimum of ten years if power is lost. No battery needed. | |
| NORMAL MODE REJECTION | 64 dB at 50/60 Hz | |
| POWER | AC power, 115 or 230 VAC ±10%, 50/60 Hz, 10 VA. DC Power, 18-36 VDC; 6 watts maximum. | |
| ENCLOSURE | 1/8 DIN, High Impact plastic, UL 94V-0 | |
| FRONT PANEL | Type 4X, NEMA 4X, Panel Gasket provided | |
| ENVIRONMENTAL | Operational ambient temperature range: 0 to +60°C. Storage temperature range: -40 to +85°C. Relative humidity: 0 to 90% non-condensing. | |
| CONNECTIONS | Removable screw terminal blocks (provided) accept 22 to 12 AWG wire. | |
| WARRANTY EXTENDED WARRANTY | 1 year parts & labor. Warranty may be extended an additional 12 months by returning the Product Registration Form within 2 months from date of purchase. <i>See Web Site: www.predig.com for online registration.</i> | |
| UL FILE NUMBER | E160849; 508 Industrial Control Equipment | |
| Options | | |
| Relays | | |
| RATING | 2 or 4 SPDT (form C); rated 2 Amp @ 30 VDC or 2 Amp @ 250 VAC resistive load; ¼ HP @ 125 / 250 VAC for inductive loads. | |

| | |
|----------------------------|--|
| RESET | User Select: 1. Automatically when input passes reset point. 2. Automatically + Manually (via user supplied switch or front panel ACK button). Manual reset resets all manually resettable relays. |
| DEADBAND | 0-100% of full scale, user selectable. |
| HIGH OR LOW ALARM | User may program any alarm for a high or low trip point. |
| FAIL-SAFE OPERATION | Relay coils are energized in non-alarm condition. In case of power failure, relays will go to alarm state. Fail-safe operation may be disabled, by removing jumper J2 located on the Options PCB. |
| AUTO INITIALIZATION | When power is applied to the meter, relays will always reflect the state of the input to the meter. |

Isolated 4-20 mA Transmitter Output

| | | | |
|-----------------------------------|--|-----------------------------|----------------------------|
| CALIBRATION RANGE | The transmitter output can be calibrated so that a 4 mA output is produced for any number displayed by the meter. The 20 mA output may correspond to any number that is at least 501 counts greater or smaller than the number corresponding to 4 mA. (Ex. 4 mA = 0, 20 mA = 501) If the span between 4 and 20 mA is less than 501 counts, an error message will appear. | | |
| EQUIPMENT NEEDED | The 4-20 mA output is calibrated without the use of a calibrator. No equipment needed. | | |
| OUTPUT LOOP-POWER | (AC Meters only), Isolated 24 VDC \pm 5% @ 20 mA regulated. Maximum loop resistance is 1200 ohms. Available for either signal input or 4-20 mA output, but not both. | | |
| ACCURACY | \pm 0.1% F.S., \pm 0.004 mA. | | |
| ISOLATION | 500 VDC or peak AC, input-to-output or input/output-to-power line. | | |
| EXTERNAL LOOP-POWER SUPPLY | 35 VDC max. | | |
| OUTPUT LOOP RESISTANCE | Power supply | Min. loop resistance | Max loop resistance |
| | 24 VDC | 10 ohms | 600 ohms |
| | 35 VDC (external) | 600 ohms | 1000 ohms |

Display Messages and Functions

The following table describes the various messages displayed by the meter during programming and operation:

| Display | Parameter | Description/Comments |
|----------------|--|--|
| E-CAL | Select External Calibration | Set meter for calibration using an external calibration source. |
| I-CAL | Select Internal Calibration | Set meter for calibration (scaling) using Internal calibration source. |
| CAL 4b | Perform External Calibration | Calibrate meter using an external calibration source. |
| SCALE | Perform Internal Calibration (scaling) | Calibrate meter (scale) using internal calibration source. (Signal source not required). |
| InPt 1 | Input 1 | Set Input 1 calibration value. |
| dSPY 1 | Display 1 | Set Display 1 calibration value. |
| InPt 2 | Input 2 | Set Input 2 calibration value. |
| dSPY 2 | Display 2 | Set Display 2 calibration value. |
| dECPt | Decimal Point | Set decimal point or light up extra "0". |
| no. Pt5 | Number of Points | Set meter for 2 to 11 calibration points. |
| L or S | Linear or Square | Set meter for Linear or Square Root calibration/scaling. |
| CutOff | Low-flow Cutoff | Set meter to display zero below programmed cutoff point. |
| RLR5 | Alarms | Program alarm/relay set and reset points. |
| outPut | Output | Set 4-20 mA output values. |
| 19999 | Overrange | Indicates input signal exceeds full-scale range of meter. |
| - 19999 | Underrange | Indicates input signal is below the negative range of meter. |
| Error | Error | Indicates calibration was not successful. |

SETUP AND PROGRAMMING

Power, Signal, External Functions & Options Connections



Disconnect power to the meter before making any connections.



Do not connect power or earth ground to any unused or CM terminals.



Observe polarity for DC powered Meters. Applying voltage with reverse polarity may damage the instrument.



Connecting 230 VAC to a meter specified to accept 115 VAC or connecting AC power to a meter specified to accept DC power will result in damage to the instrument as well as endanger personnel. Keep primary wires separated from signal cables.

Notice:

- Primary voltages must not be accessible to the user.
- Primary wires must be installed in accordance to the applicable standards.

Overview

The following field wiring connections are made to removable screw terminal blocks supplied with the meter:

Power, Signal Input, Acknowledge and Hold

Options: Relays & 4-20 mA Output

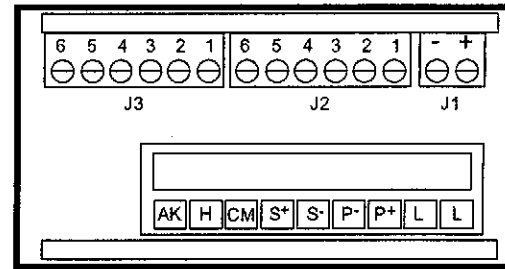

Figure 1: Rear View of Meter (Connectors)

| Label | Main PCB (Lower) | Wire Size |
|-------|------------------------------|-----------|
| None | Power | 12-18 |
| None | Signal, Acknowledge, Hold | 12-22 |
| | Options PCB (Upper) | |
| J1 | 4-20 mA Output | 12-22 |
| J2 | Relays 1 & 2; NC, NO, Common | 12-22 |
| J3 | Relays 3 & 4; NC, NO, Common | 12-22 |

Wiring Instructions

1. All field connections to be made with insulated copper wire, either solid or stranded. Tighten all screw terminals to 7 lb-in (0.8 Nm). Strip length = 1/4 in (7mm). **DO NOT** pre-treat wire with solder.
2. **Terminals L & L:** Use AWG #12-18 wire, 600 volt, 60°C. Connect only one wire to each terminal on the 9-pin connector.
3. **Terminals AK, H, CM, S+, S-, P-, P+:** Use AWG #12-22 wire, 150 volt, 60°C. If using AWG #20 or smaller wire, up to 2 wires may be connected to each terminal. If using AWG #18 or larger wire, only one wire may be connected to each terminal.

AC Powered Meters (Power, Signal, External Functions)

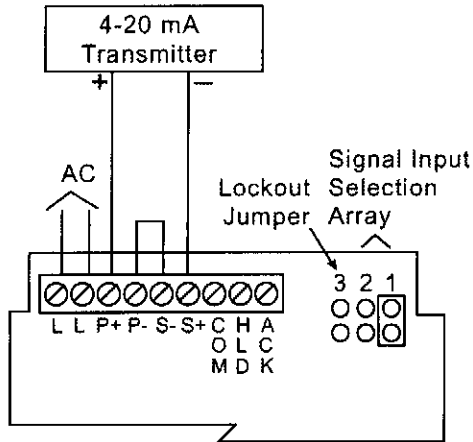

Figure 2: Transmitter Powered from Meter

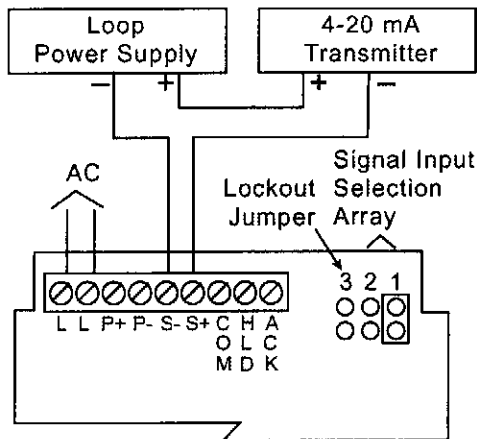

Figure 3: Transmitter Powered from External Power Supply

AC Powered Meters (Continued)

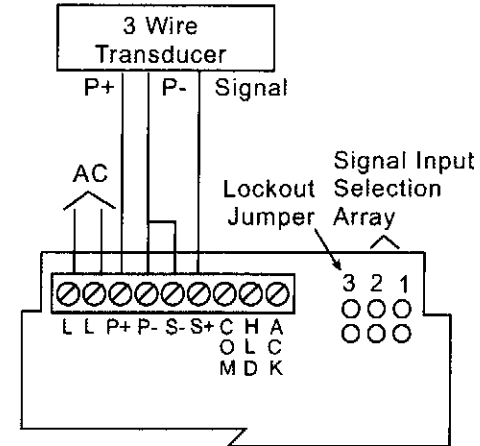

Figure 4: Three-Wire Transducer Powered from Meter

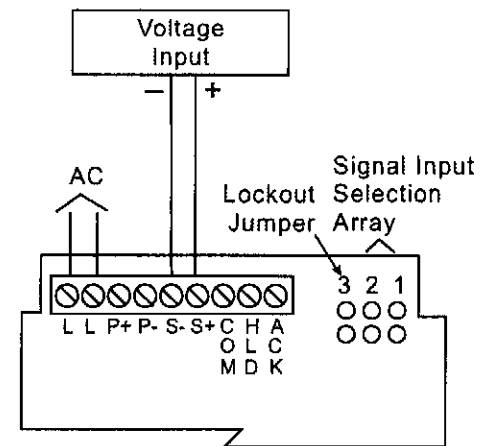

Figure 5: Voltage Input

DC Powered Meters (Power, Signal, External Functions)

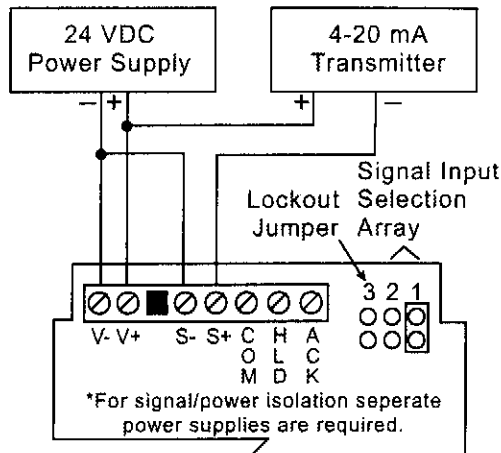

Figure 6: Transmitter and Meter Powered from Same DC Power Supply

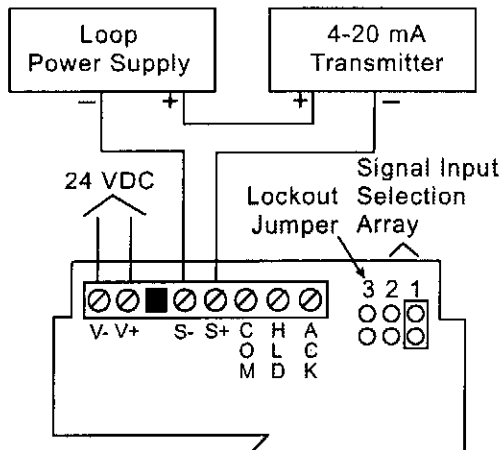

Figure 7: Transmitter and Meter Powered from Separate DC Power Supplies

Relays & 4-20 mA Output

Depending on the model number, the Options PCB may contain two or four relays and an Isolated 4-20 mA Transmitter Output. Relay connections are made to removable screw terminal connectors located at J2 and J3 on the Options PCB. Connections for the Isolated 4-20 mA Transmitter Output are made to J1 on the Options PCB.

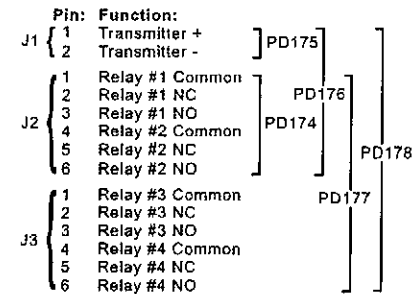

Figure 8: Option Card Pinouts

Notes:

1. Alarm acknowledgement terminals (ACK and COM) are located on the meter main board.
2. In the alarm condition, the NC contact is connected to common in the fail safe mode.

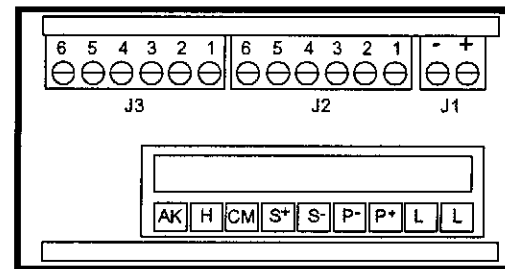

Figure 9: Rear View of Meter (Connectors)

4-20 mA Output

The 4-20 mA output from the meter can either be powered from the meter's internal transmitter power supply, (if it is not being used to power the input loop), or by an external power supply as the following diagrams illustrate:

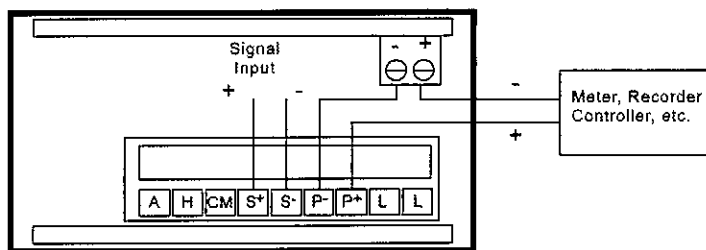

Figure 10: Meter Powering 4-20 mA Output Loop

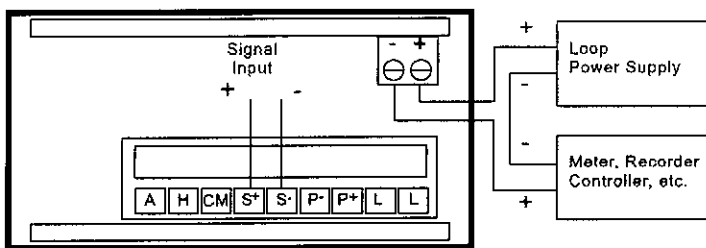

Figure 11: External Power Supply Powering 4-20 mA Output Loop



If the output loop is powered by an external supply, the loop power supply must be turned on before the meter is turned on. Otherwise, the output loop signal may be incorrect.

Programming

Overview

The meter is programmed using the **ENTER** button and three jumper arrays. The **ENTER** button controls the meter's **Single Button Scaling (SBS)** feature that allows the meter to be completely programmed using just one button. The jumper arrays are used for programming the input signal, lockout, relays acknowledge enable and relays fail-safe operation.

Single Button Scaling (SBS)

Single Button Scaling is a technique that allows the meter to be completely programmed using just the **ENTER** button. The general method behind **(SBS)** is to push **ENTER** when the meter reads the desired value. This value may be a menu title, the entire display or just a single digit. If the meter is not reading the desired value wait and the value will change. When the meter finally reads the desired display push **ENTER** to accept it.

When the meter is first powered up, it will read a random number. Pushing **ENTER** will cause the meter to scroll through the following menu titles (if the Lockout Jumper is not installed):

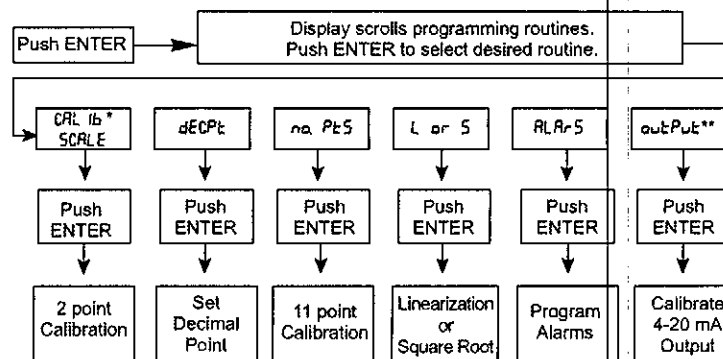

* CAR 1b appears if E-CAL is selected
SCALE appears if I-CAL is selected

** Only appears if 4-20 mA output is installed

Figure 12: Menu Scroll (with Lockout Jumper Removed)

Figure 13: Two-point External Calibration Flow Chart

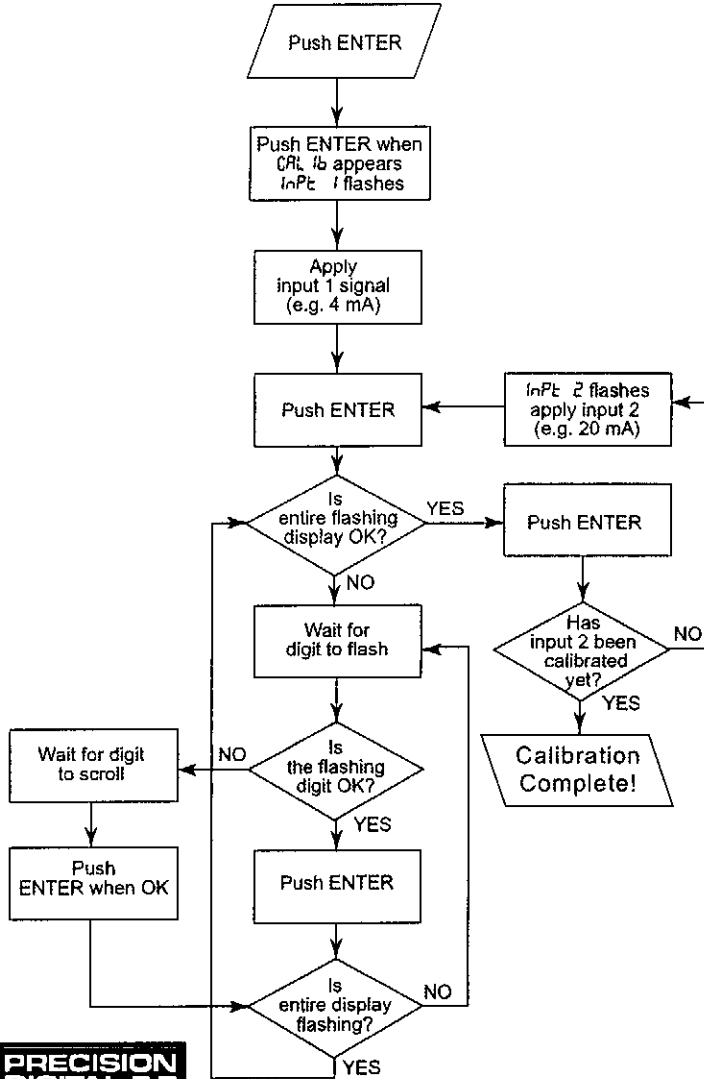

Five Basic Digit/Display-setting Instructions

Rather than repeat the **Single Button Scaling (SBS)** technique for every function it is used in, it will be detailed here and the user can refer to it when necessary.

The **Single Button Scaling** technique is used to program all the meter's functions that require numbers to be entered. For instance, calibration and scaling values, Low-flow Cutoff values, alarm set and reset points, 4 and 20 mA output values are set using **(SBS)**.

1. If the flashing display is OK, push **ENTER** before it stops flashing to accept it. (Whenever a new value is to be programmed or Most Significant Digit has been accepted the entire display flashes, if this is the desired value, press **ENTER** before it stops flashing to accept it.)
2. If the flashing display is not OK, (or if **ENTER** was not pushed in time to accept it), wait for Least Significant Digit (LSD) to flash.
3. If a flashing digit is OK, push **ENTER** before it starts to scroll to accept it.
4. If a flashing digit is not OK, (or if **ENTER** was not pushed in time to accept it), wait for the digit to scroll and push **ENTER** when OK.
5. Digits will scroll until **ENTER** is pushed. When a digit is accepted by pushing **ENTER**, the next digit to the left flashes.

Basic Meter Programming

Overview

There are four steps for programming the basic meter functions:

1. Select Input
2. Perform Initial Calibration if Needed
3. Select Calibration Method
4. Calibrate or Scale the Meter

Programmed Parameter Values

To simplify programming, the user should write down the desired programming values prior to attempting to program the meter. The form located at the back of this manual provides a convenient method to record the user settings.

Select Input Signal

The meter can be programmed to accept current or voltage input using the Signal Input Selection Array. This jumper array is located at the rear of the instrument, next to the screw terminal block. Remove jumper J3 (if installed) to disable Lockout feature.

| Input Signal | Jumper J1 | Jumper J2 |
|---------------|-----------|-----------|
| 1-5, 0-5V | OFF | OFF |
| 0-10 V | OFF | ON |
| 4-20, 0-20 mA | ON | OFF |

Table 1: Signal Input Selection Array

Initial Calibration with External Source (If Needed)

Initial calibration is required only when the *I-CAL* feature is to be used with an input other than the default input of 4-20 mA. For best results, allow the meter to warm up for at least 30 minutes.

1. Program the Signal Input Selection Array for desired input per Table 1 above.
2. Apply power with **ENTER** and **ACK** buttons pushed. Release when display stops flashing.
3. The meter scrolls through the choices **20**, **5**, and **10**. Which corresponds to input signals of 4-20 mA, 0-5 V or 1-5 V, and 0-10 V. Push **ENTER** when desired value appears.
4. The meter flashes *INPt 1*. Apply low end signal, (4 mA or 0 V)*, push **ENTER**.
5. The meter flashes *INPt 2*. Apply high end signal, (20 mA, 5 V, 10 V), push **ENTER**.
6. This completes the Initial Calibration and initializes INPUT 1 and INPUT 2 scaling points to 4.000 & 20.000 mA, 0.000 & 5.000 V, or 0.000 & 10.000 V.
7. Refer to *I-CAL* scaling below for further instructions.

*For 1-5 V input signals, calibrate the meter with input1=0 V, input 2=5 V.

Select Calibration Method

The meter may be calibrated using an external signal source, such as a calibrator (*E-CAL*), or scaled using the internal source (*I-CAL*). With *I-CAL*, a 4-20 mA input can be scaled for any display range without applying a signal. To scale inputs such as 0-5 V, 1-5 V or 0-10 V without applying a signal, it is necessary to first complete an Initial Calibration, see *Initial Calibration with External Source (If Needed)* on page 20.

Scale or Calibrate the Meter

To select a Calibration Method, apply power with **ACK** button pressed.

1. When display stops flashing, release **ACK** button. Display alternates between *E-CAL* and *I-CAL*.
2. To calibrate meter with an external source, such as a calibrator, press **ENTER** when *E-CAL* appears.
3. To scale meter with internal source, press **ENTER** when *I-CAL* appears.

Select Decimal Point (dECPt)

To program the decimal point or light up the extra "0", push **ENTER**. The meter displays *SCALE* or *CAL lb*, then *dECPt*. Push **ENTER** when *dECPt* appears. The meter then reads 199990 with the decimal point changing locations and the extra "0" illuminating. Push **ENTER** when the decimal point is in the desired position; or if the extra "0" is desired; when the extra "0" is displayed.

Select Linear Input (L or 5)

The meter can be programmed to either process the input signal in a linear fashion (L) or to take the square root of it (5). To program the meter for a linear input, push **ENTER**. When (L or 5) appears, push **ENTER** again. The meter will flash (L or 5) alternately. Press **ENTER** when (L) is flashing. After (L) is selected the meter will switch to indication mode and is ready to be calibrated.

Select Number of Calibration Points (no. Pt5)

The user may input up to 11 calibration points and corresponding displays to provide custom linearization. To program the number of calibration points, push **ENTER**, when (no. Pt5) appears, push **ENTER** again. The meter displays a number from 2 to 11 that represents the number of calibration points. Push **ENTER** when the number equals the desired number of calibration points. As soon as the number of points is programmed, the meter flashes *INPt 1* (Indicating it is ready to be calibrated). Refer to *Scale Using Internal Calibration (I-CAL)*, page 22 or *Calibrate Using an External Calibrator (E-CAL)* on page 23.

General Calibration/Scaling Instructions

Calibration is performed from the front panel using the **ENTER** button. It does not require any tools or disassembly of the meter. A calibrated signal source is required if external calibration (E-CRL) is selected.

For best results, allow meter to warm up for at least 30 minutes.

The calibration input signals must be within the range of the meter and input 2 must be greater than input 1. (However, display for input 2 does not have to be greater than desired display for input 1.)

An *Error* message will appear if input 1 signal and input 2 signal are too close together:

| Input Range: | Minimum Difference Between Input 1 & Input 2: |
|--------------|---|
| 0-5 V | 0.16 V |
| 0-10 V | 0.32 V |
| 4-20 mA | 1.60 mA |

Table 2: Input Range Minimum Spans

Scale Using Internal Calibration (I-CRL)

If I-CRL (Internal Calibration) was selected above in *Select Calibration Method*, the meter can be scaled without applying an input. Desired values can be programmed using the *Five Basic Digit/Display-setting Instructions* described on page 19. See Figure 13: *Two-point External Calibration Flow Chart* on page 18.

1. Push **ENTER**, when 5CRL E appears push **ENTER** again.
2. *inPt 1* flashes. Push **ENTER** and program desired value for input 1.
3. *dSPY 1* flashes. Push **ENTER** and program desired value for display 1.
4. *inPt 2* flashes. Push **ENTER** and program desired value for input 2.
5. *dSPY 2* flashes. Push **ENTER** and program desired value for display 2.

Calibrate Using an External Calibrator (E-CRL)

If E-CRL (External Calibration) was selected above in *Select Calibration Method*, the meter must be calibrated with an external calibrator. Desired values can be programmed using the *Five Basic Digit/Display-setting Instructions* described on page 19. See Figure 13: *Two-point External Calibration Flow Chart* on page 18.

1. Push **ENTER**, when CRL 1b appears push **ENTER** again.
2. *inPt 1* flashes. Apply input 1 signal (e.g. 4mA, 1V, etc.) then push **ENTER**, Program desired display for input 1.
3. *inPt 2* flashes. Apply input 2 signal (e.g. 20 mA, 10 V, etc.) then push **ENTER**. Program desired display for input 2.

Calibration Error (Error)

A meter display of *Error* during calibration indicates that the calibration process was not successful and the meter needs to be recalibrated.

1. The *Error* message will appear if input 1 signal and input 2 signal are too close together, see Table 2 on page 22.
2. The *Error* message will appear if input 1 signal is inadvertently also applied for input 2 calibration, or **ENTER** is pushed before applying input 2.

Programming Confirmation

The values that have been programmed can be quickly checked to make sure they are the desired values. To do this, apply the desired signal for each point and check the display.

Select Square Root Extraction (L or 5)

With the square root extraction function activated, the meter takes the square root of the input signal (the output from a differential pressure transmitter) and displays flow rate. The square root extraction feature is calibrated using the same **Single Button Scaling** technique that is used for two-point linear calibration. Calibration involves setting only three points: the zero flow rate (usually zero), the high flow rate and the Low-flow Cutoff point.

To program the meter for square root extraction, push **ENTER**. When (L or 5) appears, push **ENTER** again. The meter will flash (L or 5) alternately. Push **ENTER** when (5) is flashing. After (5) has been selected the meter will switch to indication mode and is ready to be calibrated.

Program Low-flow Cutoff (Cutoff)

Low-flow Cutoff allows the meter to be programmed so that the often unsteady output from a differential pressure transmitter at Low-flow rates always displays zero on the meter.

Example: If Low-flow Cutoff is set at 12, any rate less than 12 will be displayed as "0".

To program Low-flow Cutoff:

1. Push **ENTER**, when *Cutoff* appears push **ENTER** again.
2. Set Low-flow Cutoff per *Five Basic Digit/Display-setting Instructions* on page 19.

Notes:

1. To disable Low-flow Cutoff, program cutoff value to zero.
2. Low-flow Cutoff is only available when using Square Root Extraction.

Round Horizontal Tank Calibration Table

The following tables can be used to calibrate the meter for displaying volume in a round horizontal tank. The right-most column in each table gives an example of actual calibration points for a 500-gallon tank.

Number of Points: 10

Maximum Error: 0.3% Full Scale

| Calib. Point | Input (mA) | Display: (% Volume) | Display: (Example) (500 Gallon Tank) |
|--------------|------------|---------------------|--------------------------------------|
| 1 | 4.0 | 0.00 | 0.0 |
| 2 | 4.8 | 1.80 | 9.0 |
| 3 | 6.0 | 7.20 | 36.0 |
| 4 | 7.2 | 14.20 | 71.0 |
| 5 | 9.2 | 28.10 | 140.5 |
| 6 | 14.8 | 71.80 | 359.0 |
| 7 | 16.8 | 85.80 | 429.0 |
| 8 | 18.0 | 92.80 | 464.0 |
| 9 | 19.2 | 98.10 | 490.5 |
| 10 | 20.0 | 100.00 | 500.0 |

Number of Points: eight

Maximum Error: 0.5% Full Scale

| Calib. Point | Input (mA) | Display: (% Volume) | Display: (Example) (500 Gallon Tank) |
|--------------|------------|---------------------|--------------------------------------|
| 1 | 4.0 | 0.00 | 0.0 |
| 2 | 4.8 | 1.90 | 9.5 |
| 3 | 6.4 | 9.50 | 47.5 |
| 4 | 8.4 | 22.40 | 112.0 |
| 5 | 15.6 | 77.70 | 388.5 |
| 6 | 17.7 | 90.50 | 452.5 |
| 7 | 19.2 | 98.10 | 490.5 |
| 8 | 20.0 | 100.00 | 500.0 |

Table 3: Round Horizontal Tank Calibration Points

Isolated 4-20 mA Transmitter Output Programming (*outPut*)

The Isolated 4-20 mA Transmitter Output option can be programmed without a calibrator. This option can be calibrated so that a 4 mA output is produced for any number displayed by the meter. The 20 mA output may be programmed to correspond to any number that is at least 501 counts greater or smaller than the number corresponding to 4 mA. (Ex. 4 mA = 0, 20 mA = 501 or -501) If the span between 4 and 20 mA is less than 501 counts, an *Error* message will appear and the previously programmed values will be retained in memory until a new set of values is accepted.

Setting 4 mA Output Value

1. Push **ENTER**, when *outPut* appears push **ENTER** again.
2. All digits flash for 3 seconds, a green LED labeled "4" illuminates indicating the flashing display is the value at which the meter will produce a 4 mA output. Program desired value per *Five Basic Digit/Display-setting Instructions* on page 19.

Setting 20 mA Output Value

1. When **ENTER** is pushed to complete the programming for 4 mA output, the green LED labeled "20" illuminates indicating the flashing display is the value at which the meter will produce a 20 mA output.
2. Program desired value per *Five Basic Digit/Display-setting Instructions* on page 19.
3. An Error message will be displayed if the 4-20 mA output span is smaller than 501 counts.

Programming Confirmation

The values that have been programmed to produce the 4 & 20 mA outputs can be quickly checked to make sure they are the desired values. To do this, enter the *outPut* routine by pushing **ENTER** and then pushing **ENTER** again when *outPut* appears.

The green "4" LED illuminates indicating the meter is displaying the value at which it will produce a 4 mA output. Confirm that this is the desired value. Push **ENTER** (within 3 seconds) before the entire display stops flashing and the green "20" LED illuminates indicating the meter is displaying the value at which it will produce a 20 mA output. Confirm that this is the desired value. Push **ENTER** (within 3 seconds) before the entire display stops flashing and the meter returns to indication mode.

Alarm Programming

Overview

The meter is equipped with four alarm points as a standard feature. Each alarm may be programmed for either a high or low alarm and for 0-100% deadband. Front panel LEDs indicate alarm status.

Options for two or four relays are available.

To program a high alarm, program the set point above the reset point. To program a low alarm, program the set point below the reset point. To program the alarm deadband, set the reset point above or below the set point by an amount equal to the desired deadband value.

Example: Alarm 2 is a high alarm that trips at 1500 and has a deadband of 100. Alarm 2 set point is set at 1500 and its reset point at 1400.

Setting Alarm Set & Reset Points (*ALRr-5*)

Alarm Set and Reset points are programmed using the *Five Basic Digit/Display-setting Instructions* described on page 19.

1. Push **ENTER** and when *ALRr-5* appears, push **ENTER** again. This starts a scan of the four alarm set & reset points. The scan sequence begins with a flashing display of alarm #1 set point. The "1" LED and "S" LED below the display are illuminated to indicate the meter is flashing alarm #1 set point value. Program the desired value for alarm #1 set point using the *Five Basic Digit/Display-setting Instructions* described on page 19.
2. After Alarm #1 set point has been programmed, the meter displays Alarm #1 reset point, as indicated by the "1" LED and "R" LED below the display. Program the desired value for alarm #1 reset point using the *Five Basic Digit/Display-setting Instructions* described on page 19.
3. Program the remaining alarm set and reset points in a similar fashion.
4. When alarm programming is complete the meter will display the process input signal and the front panel LEDs will indicate alarm status.

Programming Confirmation

To verify that the alarm set and reset points have been programmed as desired, push **ENTER**, and push **ENTER** again when *RLR-5* appears. Before the display stops flashing #1 set point value, push **ENTER** again to advance the display to #1 reset point. Continue skipping through the remaining alarm set and reset points. To alter an alarm point value, wait for the first digit to flash and program the desired value using the *Five Basic Digit/Display-setting Instructions* on page 19.

Alarm Operation

When the meter detects an alarm, a front panel LED illuminates to indicate which alarm point has tripped. This LED will stay illuminated until the meter display passes through the reset point.

Set Relays for Fail-safe Operation

In the fail-safe mode, the relay coils are energized and the Normally Open (NO) contacts are connected to the Common (C) contacts under normal operation. During an alarm condition, the relay coils are *de-energized*, the Normally Closed (NC) contacts are connected to the Common (C) contacts. During a power failure the relay contacts reflect an alarm condition.

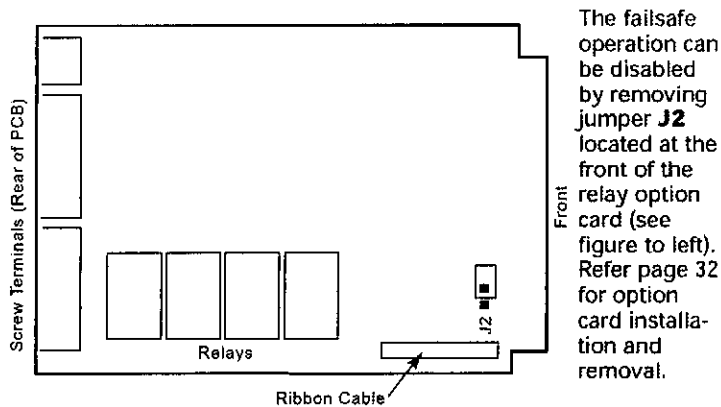

Figure 14: Option Card Installation

Alarm Acknowledgment

The ACK button on the front panel resets the optional relays only and has no effect on the alarm status LEDs.

Automatic & Manual Reset Programming

There are two ways to reset the relays:

1. Automatically when the signal passes through the reset point.
2. Automatically + manually via the front panel ACK button, or a user supplied momentary Normally Open push-button across terminals AK and CM at the rear of the instrument. That is, a relay may be manually reset prior to the signal passing through the reset point or it will automatically reset when the signal passes through the reset point.

A manual reset will reset all relays that are programmed for automatic + manual reset.

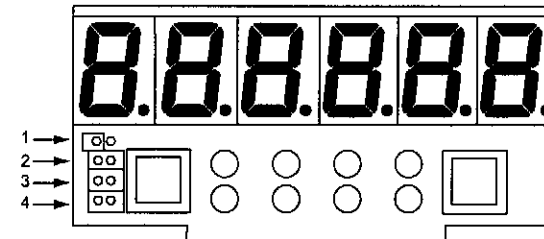

Figure 15: Relay Reset Jumpers

An array of jumpers located behind the front panel on the Display PCB is used to program each relay for either automatic or automatic + manual reset. Refer to page 32 for front panel removal instructions. The top jumper is used for relay 1, the next for relay 2, etc. A relay will automatically reset if no jumper is installed. A relay will automatically reset, plus can be manually reset, if a jumper is installed over its respective pins.

Example Above: Relay 1 is programmed for automatic reset; Relays 2, 3, & 4 are programmed for automatic + manual reset.

Lockout Jumper

Once the meter has been completely programmed, a lockout jumper can be installed to restrict further modification to the meter. This jumper is located at the rear of the instrument and is labeled J3. When **ENTER** is pushed with the lockout jumper in place, only *Rt*, *Rr* 5 and *outPut* routines are displayed. These routines may be entered to view their settings, but the settings may not be altered.

SWITCHING INDUCTIVE LOADS

The meter has the ability to suppress electrical noise generated by switching inductive loads. However, installing Resistor Capacitor (RC) Networks improves this performance and prolongs the life of the meter's relay contacts. This suppression can be obtained with RC networks assembled by the user or purchased as a complete assembly. Refer to the following circuits for RC network assembly and installation:

AC & DC Loads

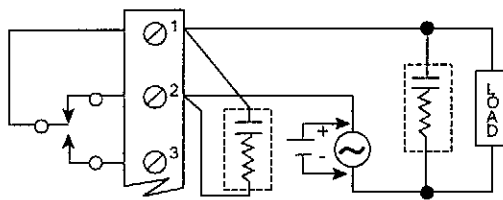

Figure 16: AC & DC Loads

Choose R and C as follows:

- R: 0.5 to 1 ohm for each volt across the contacts
 C: 0.5 to 1 microfarad for each 1 A through closed contacts

Notes:

1. Use capacitors rated for 240 VAC.
2. Snubbers may affect load release time of solenoid loads, check to confirm proper operation.
3. Install the RC network right at the meter's relay screw terminals. An RC network may also be installed across the load.

Low Voltage DC Loads

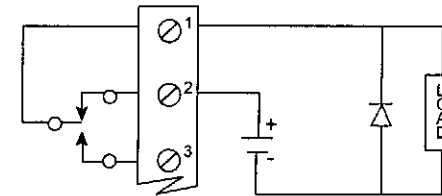

Figure 17: Low Voltage DC Loads

Use a diode with a reverse breakdown voltage two to three times the circuit voltage and forward current at least as large as the load current.

RC Networks Available from Precision Digital

RC Networks are available from Precision Digital and should be applied to each relay contact that switches an inductive load. Part number PDX6901.

OPTION CARD INSTALLATION

Options may be ordered installed at the factory or as separate items.

Instructions

1. **Disconnect power to the meter.**
2. Remove all connectors from the back of the meter.
3. Remove the Front Cover, simply pry the top and pull it back.
4. Remove the two screws that retain the PCB.
5. Slide the Main PCB out of case (set it down with display facing forward).
6. Lay the Option PCB to the right of the Main PCB.
7. Connect flexible cable connector CT1 to J5 connector on Main PCB.
8. Check that all the pins are properly seated in the connector.
9. Fold the option board over onto the Main PCB.
10. Slide the two PCBs into the case and secure with four screws and washers.
11. Reassemble front covers and install connectors.

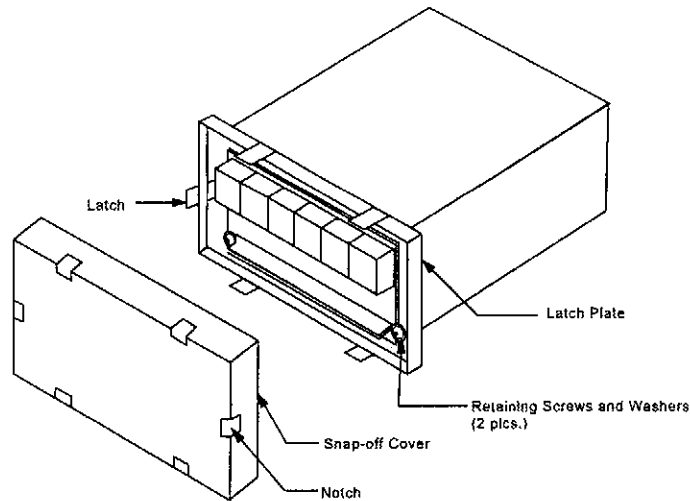
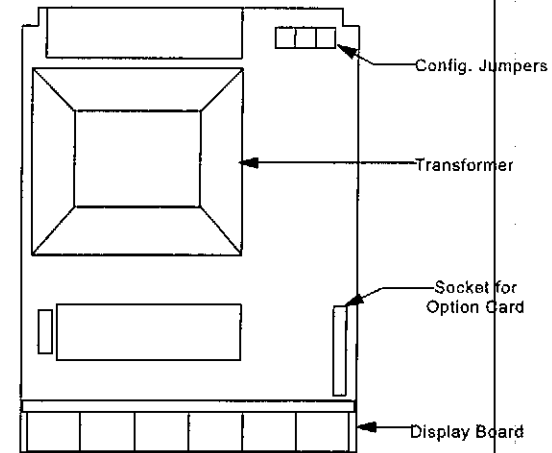

Figure 18: Removing Front Bezel



Internal View of Meter for Locating Option Connector

Figure 19: Internal View of Meter (Option Card Socket)

MOUNTING DIMENSIONS

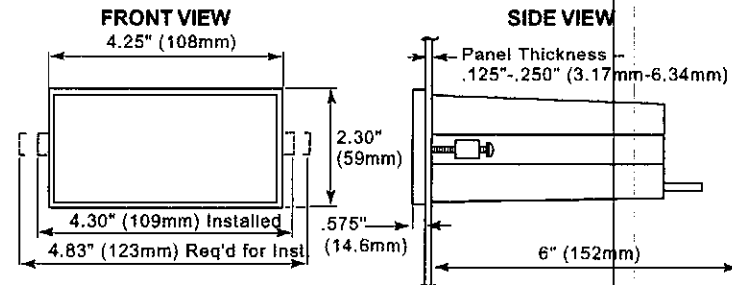

Figure 20: Mounting Dimensions

Notes:

1. Panel cutout required: 1.772" X 3.622" (45 mm x 92 mm) 1/8 DIN
2. Panel thickness: 0.125" - 0.250" (3.17 mm - 6.34 mm)
3. Allow 6 inches (152 mm) behind the panel
4. Weight: 16 oz (454 g)

PROGRAMMED PARAMETER SETTINGS

Use the following table to record how your meter is programmed:

Input

4-20 mA 0-5 V 1-5 V 0-10 V

Linear or Square Root Extraction

Number of Calibration Points _____

Low-flow Cutoff Value _____

Calibration Point Values

| | |
|--------------------------|------------------|
| Input 1 set point _____ | display 1 _____ |
| Input 2 set point _____ | display 2 _____ |
| Input 3 set point _____ | display 3 _____ |
| Input 4 set point _____ | display 4 _____ |
| Input 5 set point _____ | display 5 _____ |
| Input 6 set point _____ | display 6 _____ |
| Input 7 set point _____ | display 7 _____ |
| Input 8 set point _____ | display 8 _____ |
| Input 9 set point _____ | display 9 _____ |
| Input 10 set point _____ | display 10 _____ |
| Input 11 set point _____ | display 11 _____ |

Alarms

| | |
|-------------------------|-------------------|
| Alarm 1 set point _____ | reset point _____ |
| Alarm 2 set point _____ | reset point _____ |
| Alarm 3 set point _____ | reset point _____ |
| Alarm 4 set point _____ | reset point _____ |

4-20 mA Output Option

4 mA display value _____
 20 mA display value _____

Model Number: PD690 _____ Serial Number: _____

OTHER PRECISION DIGITAL PRODUCTS

| Model | Description |
|-----------|---|
| PD118 | MINIMUX® 8 Point Scanner |
| PD128 | PLC Annunciator |
| PD141AFO | VIGILANTE® four Point Annunciator with First-out |
| PD650 | 2.3" LED NEMA 4X Large Display Process Meter |
| PD655 | 1.0" LED NEMA 4X Large Display Process Meter |
| PD656 | 0.8" LED Exp-Proof Large Display Process Meter |
| PD750 | 1/8 DIN Universal Temperature Meter |
| PD755 | 1.0" LED NEMA 4X Large Display Temperature Meter |
| PD756 | 0.8" LED Exp-Proof Large Display Temperature Meter |
| PD757 | 2.3" LED NEMA 4X Large Display Temperature Meter |
| PD660 | Low-cost NEMA 4X Loop-powered Meter |
| PD661 | Low-cost Exp-proof Loop-powered Meter |
| PD673/674 | 4½ Digit Loop-powered 1/8 DIN Meter |
| PD675/676 | 4½ Digit Loop-powered NEMA 4X Meter (FM Approved) |
| PD677/678 | 4½ Digit Loop-powered Exp-proof Meter |
| PD680 | 3½ Digit Loop-powered 1/8 DIN Meter |
| PD682 | 3½ Digit Loop-powered 1/8 DIN Meter (FM Approved) |
| PD686 | 3½ Digit Loop-powered NEMA 4X Meter (FM Approved) |
| PD687 | 3½ Digit Loop-powered Explosion-proof Meter |
| PD691 | 1/8 DIN Universal mV Strain Gauge & Load Cell Meter |
| PD692 | 1/8 DIN Analog Input Flow Rate/totalizer |
| PD693 | 1/8 DIN Frequency/Pulse Input Flow Rate/totalizer |
| PD694 | 1/8 DIN 0-200 DC Volt Meter |
| PD695 | 1/8 DIN True RMS AC Volt Meter |
| PD696 | 1/8 DIN Loop-powered Flow Rate/totalizer |
| PD697 | NEMA 4X Loop-powered Flow Rate/totalizer |
| PD698 | Explosion-proof Loop-powered Flow Rate/totalizer |

How to Contact Precision Digital

- For Technical Support please
call: (800) 610-5239
fax: (508) 655-8990
e-mail: support@predig.com
- For Sales Support or to place an order please
call: (800) 343-1001
fax: (317) 216-1277
e-mail: sales@predig.com
- For Warranty Registration and to Double Your
Warranty on-line please visit
www.predig.com
- For an online version of this instruction manual
please visit
www.predig.com



PRECISION DIGITAL CORPORATION
19 Strathmore Road • Natick MA 01760 USA
Tel 800-610-5239 • Fax 508-655-8990

LIM690 Rev C
6/00