



HALE®

FULL LINE CATALOG



DESIGNED



MACHINED



ASSEMBLED



TESTED



HALE PRODUCTS

100+ YEARS OF FIRE SUPPRESSION INNOVATION, QUALITY AND PERFORMANCE

Our mission is to provide the highest performing and most reliable mobile fire suppression delivery systems the industry has to offer. With over 100 years of technical expertise, HALE PRODUCTS has been a leading developer and provider of fire suppression solutions to first responders all over the world.

With great pride and a long history of serving customers, Our goal has never wavered – to ensure that every customer will see the quality and pride in every product we deliver. Trust is earned, not given. From our Ocala Florida manufacturing facility, the employees of HALE strive every day to design, machine, assemble and test our products and be your trusted partner in fire suppression delivery systems.

As always, we thank you for that trust and your business.

Gary M. Pacilio
Vice President, Fire Suppression Group
– Hale Products
A Unit of IDEX Corporation



HALE's 140,000 ft² (13,000 m²) Manufacturing Facility in Ocala, Florida

table of contents

Pumps

Manifolded4-5

Qmax-XS
Qmax®
Qtwo
Qflo Plus

Non-Manifolded 7-9

CBP
2CBP
AP
TBP
MBP
MG
DSD
RSD

Pump Accessories11-13

Godiva®15-16

KP1
KP2
Prima P1
Prima P2

Industrial High Flow18-20

8FK
8FG
80FC
80FCG
80FCK
RME
DFG

Split Shaft Gearboxes 23

MGA
RGA
LGA
LKA

Special Applications 25-26

Modules

Pump Modules & Kits 28-30

Electronics

Pressure Governors 28-30

Sentry
TPG+
TPG
Captain
Twister®
Envo III
Envo IV
ITL-40
ITL-4

Portables Pumps

Floating & Backpack Pumps 39

Super Chief
Fyr Flote®
Fyr Pak®

Wildland Firefighting Pumps 40

HPX75-B18
HPT75-B18
HPX75-YD9
HPX75-KBD24
HPX75-B23

Attack Firefighting Pumps 41

HPX200-B18
HPT200-B18
HPX200-B23
HPX200-KBD24
HPX200-H20

High Flow Pumps 42

HPX275-B35
HPX300-B18
HPT300-B18
HPX300-KBD24
HPX400-B18
HPT400-B18
HPX450-B35

Foam Systems

SmartFOAM®44-45

SmartCAFS®46-47

SmartATP® 48

Foam Accessories49-50

Gauges

Pressure Gauges52-53

Gauge Bezels53-54

QC Test Kits 54

Plumbing

Plumbing Accessories56-76

Technical Data

Technical Data78-92

Pump Gearbox and
Seal Compatibility
NFPA Rated Flows
NFPA Discharge Ratings
Pump Rated Flow Ranges
Pump Port Sizes & Flows
Pump Model Comparisons
NFPA 1906 Pump
Selection Guide
PowerFlow Portables
Application Guide
Portable Pump Curves
Foam System Selection
Metric Conversations
Index
Customer Support

MANIFOLDED





Manifolded

Hale writes the book on how to get the most from a pumping system. We don't stop at the basics of good pump design. We take it to the max. We hand grind and fettle our impellers and optimize our pumps manifold design with the most direct water flow path in the industry. Hale's manifolded pumps' unique porting arrangements provide apparatus builders options for installing secondary plumbing while being unchallenged when it comes to single port flow output capabilities.

The list of features keeps getting longer as we build on our traditions of performance, reliability, and innovation. See why Hale is the pump leader and why our pumps have been the most popular in North America for the past two decades.

Features:

- Low friction loss allow single port flows of up to 1,500 gpm (5678 lpm) on 3" ports and 2,600 gpm (8942 lpm)* on 4" ports
- Smooth water flow delivery to the cast pump body with no twists, turns or restrictions that add turbulence
- One piece upper pump body minimizes potential piping leaks while allowing easier access to critical components making maintenance and service easy
- Hale's Auto-lube system is a front bearing assembly that:
 - Automatically lubricates itself with oil
 - Seals out dirt and water
 - Shortens the pump shaft and overall pump length
 - Eliminates the need for a second packing or seal
- Optimized pump shaft design supports the shaft close to the impeller minimizing deflection reducing unnecessary wear on the shaft, impeller, clearance rings and bearings
- Standard with G series gearbox rated at 16,000 lb-ft of torque (Optional K series gearbox rated at 18,500 lb-ft of torque)

Qmax-XS Featured

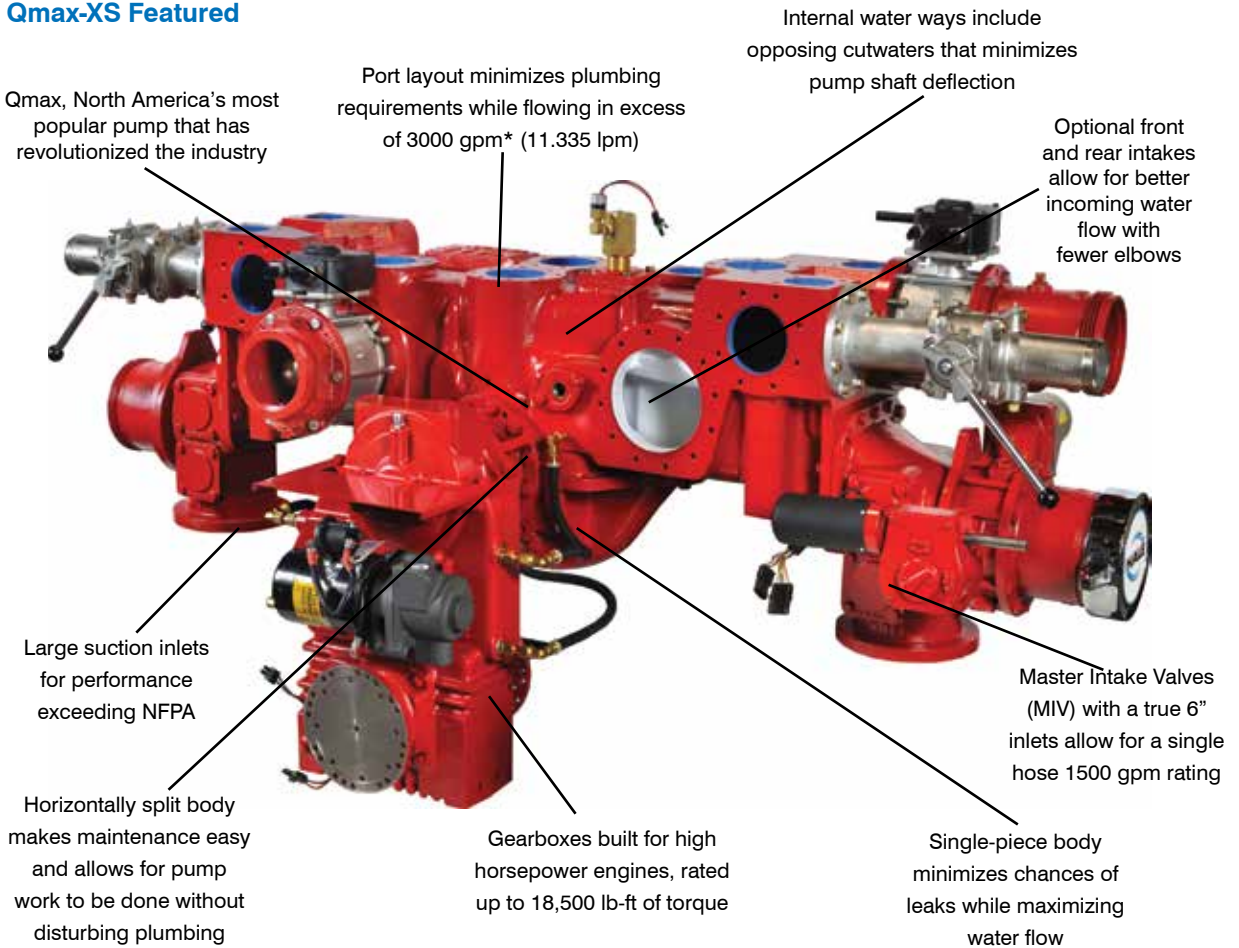

Pump	NFPA Rated gpm (lpm)	Stage	Material	Drive Type
Qmax-XS	2250 (8515)	Single	Iron	Split Shaft, PTO
Qmax	2250 (8515)	Single	Iron	Split Shaft, PTO
Qtwo	2000 (7570)	Two	Iron	Split Shaft, PTO
Qflo-Plus	1250 (4732)	Single	Iron	Split Shaft, PTO

*Higher flows require a positive water source

Qmax-XS

NFPA Rating: 2250 gpm (8515 lpm)
Stage: Single

The Hale Qmax-XS gives you endless possibilities with its wide performance range, hardcore power and massive flow capabilities in a compact design. Engineered to exceed its NFPA rating, the Qmax-XS can provide over 3,000 gpm (11,335 lpm)* from a sufficient positive pressure water source when paired with an appropriate engine. Based on the impressive track record of the Qmax pump, this efficient innovative design gives your department all that it is looking for in a pump.

- 12 standard 4" ports maximize single port flow of up to 2,600 gpm (9,842 lpm)
- Innovative one-piece compact body profile design:
 - Minimizes piping requirements
 - Maximizes space for storage compartments on your apparatus
- Enables reduced pump module width as narrow as 34" (865 mm) with manual valves or 28" (710 mm) with electric valves



Qmax

NFPA Rating: 2250 gpm (8515 lpm)
Stage: Single

Hale's Qmax is North America's most popular single stage manifolded pump that has revolutionized the industry over the past two decades. Its impressive track record based on outstanding performance and proven reliability make it the benchmark of the industry and the right choice for your next apparatus.

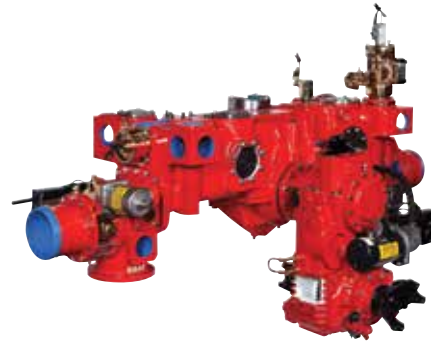

Qtwo

NFPA Rating: 2000 gpm (7570 lpm)
Stage: Two

Hale's Qtwo two-stage pump provides unrivaled power and reliability. The Qtwo is based on the Qmax pump, the bestselling single-stage pump in North America. Its strong flow rate knocks down large fires while its high pressure delivery is great for high-rise applications. The Qtwo equipped with an adequate engine can flow over 3500 gpm* for excellent high flow performance.



Qflo-Plus

NFPA Rating: 1250 gpm (4732 lpm)
Stage: Single

Hale's Qflo-Plus single stage manifolded pump is lighter than current split shaft pump designs resulting in lower loads on the chassis. The compact design of the Qflo Plus results in a shorter pump module allowing a shorter vehicle or increased compartment room for water tanks, equipment, or personnel.



* Higher flows requires a positive water source



Non-Manifolded

HALE PRODUCTS INC | PH. 800.533.3569 | haleproducts.com



Hale manufactures a full line of versatile non-manifolded pumps. This versatile line is suited for many unique and specialty applications. Various models of our non-manifolded pumps are driven with split shaft gearboxes like our manifolded pumps while others feature PTO drives and can deliver NFPA 1901 rated performance from 250 gpm (950 lpm) up to 1500 gpm (5680 lpm). These units are well suited for apparatus that require substantial flow, but have weight or space as an issue. Compact size, innovative options, and gearbox configurations make these ideal for your special apparatus challenges.

Features:

- Hard, fine grain bronze, mixed flow impeller design is hand ground and balanced for maximum performance and corrosion resistance
- For minimal maintenance, the spring-loaded mechanical seal is self-adjusting and self-lubricating
- Heavy duty precision ground, deep groove bearings used for long-life
- Heat treated, one piece stainless steel pump shaft has been designed for strength and to minimize pump deflection
- Bronze clearance rings are easily replaceable

RSD Featured

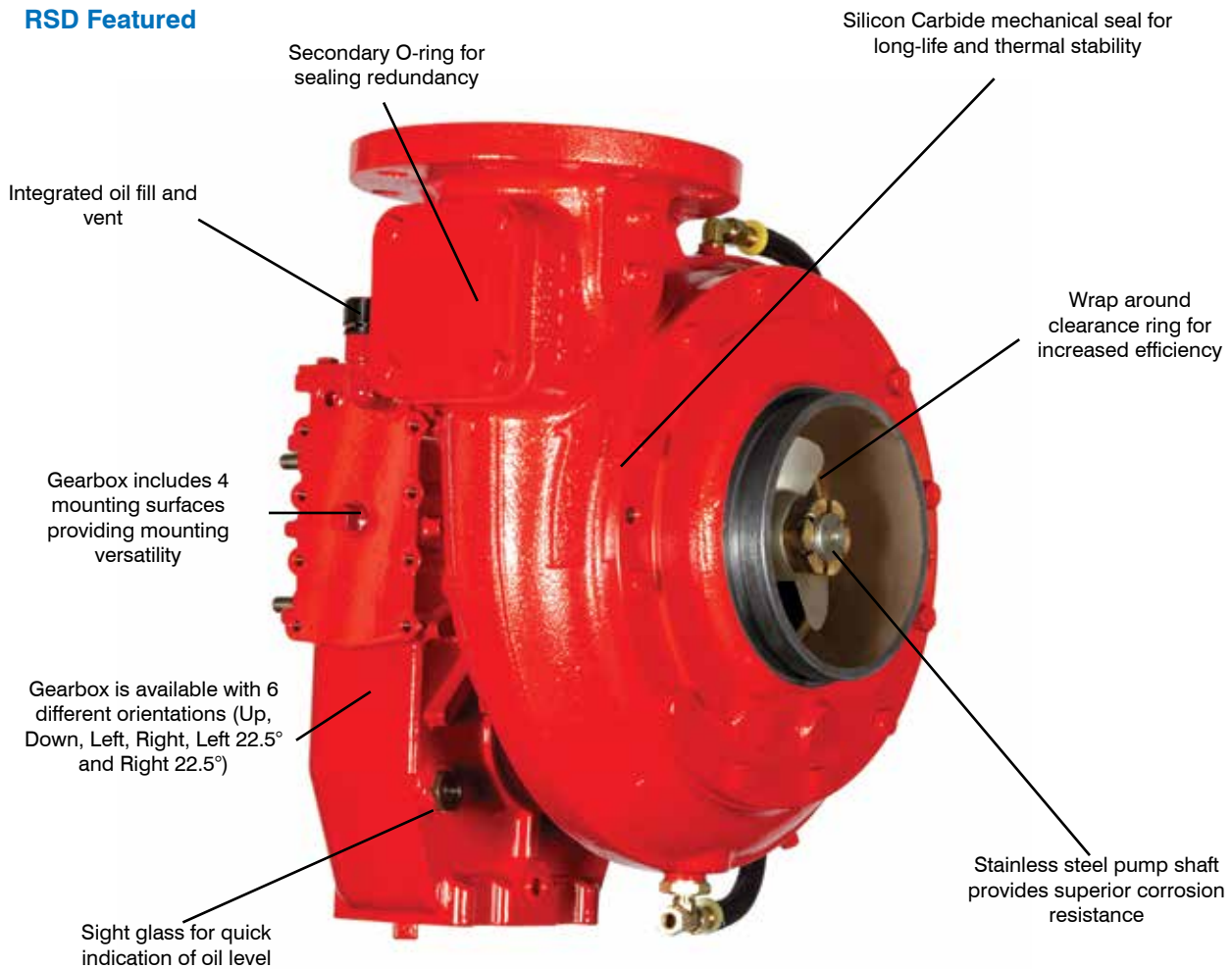

PUMP	RATED FLOW gpm (lpm)	VOLUME gpm (lpm)	STAGE	MATERIAL	DRIVE TYPE
CBP	250 (1000)	400 (1500)	Single	Iron or Bronze	PTO, , Engine
2CBP	80 (303)	100 (380)	Two	Iron or Bronze	PTO, Hydraulic, Engine
AP	500 (1893)	700 (2650)	Single	Iron or Bronze	PTO, Engine (APMG - Split Shaft)
TBP	750 (2839)	1000 (3785)	Two	Iron or Bronze	PTO, Hydraulic, Engine
MBP	1000 (3785)	1300 (4921)	Single	Iron or Bronze	PTO, Engine
MG	1000 (3785)	1300 (4921)	Single	Iron or Bronze	Split Shaft, PTO
DSD	1500 (5678)	2000 (7570)	Single	Iron or Bronze	Split Shaft, PTO
RSD	1500 (5678)	2000 (7570)	Single	Iron or Bronze	PTO, Engine



Non-Manifolded

haleproducts.com

PH. 800.533.3569

HALE PRODUCTS INC

CBP

NFPA Rating: 250 gpm (1000 lpm)
Stage: Single

Hale's most compact PTO pump ideally suited for initial attack, booster, and transfer auxiliary pump duty. The space saving design allows for maximum space for water tank and components. The CBP puts heavy duty performance in a lightweight package.

- Available in engine mount CBP
- Available in engine and opposite engine rotation
- Available in cast iron or bronze



2CBP

Rating: 80 gpm (303 lpm) @150 psi
Stage: Two

The 2CBP two-stage centrifugal high pressure booster pump is high on performance but low on both power and maintenance requirements. This lightweight pump serves well in an initial attack vehicle. Versatile and cost effective, the 2CBP can provide up to 1,000 psi (69 bar) of pressure and volumes up to 100 gpm (380 lpm).

- Available with hydraulic adapter (2CBPH)
- Available in engine mount (2CBP = 20FS)



AP

NFPA Rating: 500 gpm (1893 lpm)
Stage: Single

AP series pumps serve as the first line of defense in firefighting ideally suited for supply lines, pre-connects, and booster lines in mini-pumpers, first-out units, and tanker/tenders. The AP can provide flows up to 700 gpm (2650 lpm) from tank and pressures up to 350 PSI (24.1 bar).

- APM available in engine mount
- Available in engine and opposite engine rotation
- Available in cast iron or bronze



APMG – Split Shaft, AP Pump with heavy-duty 16,000 lb-ft of Torque Gearbox

TBP

NFPA Rating: 750 gpm (2839 lpm)
Pressure Mode: 150 gpm (568 lpm) @ 500 psi (35 bar)
Stage: Two

TBP Twin Booster pump is a unique two-stage series/parallel pump that meets the demands for higher pump performance for structural fires while still retaining the ability to create the high pressures necessary to operate progressive hose lays and low speed pump and roll. The TBP is the first 750 gpm NFPA rated two stage series/parallel PTO driven fire pump.

- Available with hydraulic adapter (TBPH)
- Pressure Mode 150 gpm @ 500 psi
- Available in engine mount (TBPM)
- Available in engine and opposite engine rotation
- Available in cast iron or bronze



MBP

NFPA Rating: 1000 gpm (3785 lpm)
 Stage: Single

The first line of defense in firefighting ideally suited for supply lines, pre-connects, and booster lines in mini-pumpers, first-out units, and tanker/tenders, the MBP can provide flows up to 1300 gpm (4921 lpm) from the tank and pressures up to 350 psi (24.1 Bar).

- Available in engine mount
- Available in engine rotation
- Available in cast iron or bronze



MG

NFPA Rating: 1000 gpm (3785 lpm)
 Stage: Single

The most compact manifolded pump designed to fill the gap between a standard attack pump and a full-range non-manifolded pump. The lightweight and compact MG pump is built to fit the chassis of most commercially built fire trucks and tankers, "mini," "midi," or attack pumpers, field or brush trucks, and mid or full-size tankers.

- Heavy-duty 16,000 lb-ft of Torque Split Shaft Gearbox
- Available in engine rotation
- Available in cast iron or bronze

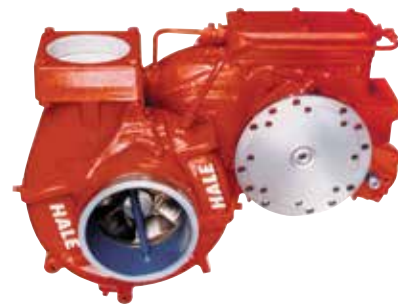

DSD

NFPA Rating: 1500 gpm (5678 lpm)
 Stage: Single

The DSD pump is one of Hale's most demanded non-manifolded pump. The DSD uses the same reliable G gearbox that is used on all of our split shaft pumps. The DSD has the ability to produce up to 2000 gpm from hydrant with a positive water source. The DSD is a standout against the competition.

- Heavy-duty 16,000 lb-ft of Torque Split Shaft Gearbox
- Available with front or rear facing volute
- Available in cast iron or bronze



RSD

NFPA Rating: 1500 gpm (5678 lpm)
 Stage: Single

The RSD pump is the PTO version of the popular DSD. Ideally suited for ARFF and rear mounted applications. With the ability to produce up to 2000 gpm with a positive water source and sufficient horsepower the RSD brings high performance to the rear mount market. Its compact design along with the gearbox and volute options allow for maximum truck design flexibility.

- Helical heat treated gears for strength and quiet operation
- Available in engine and opposite engine rotation
- Available in cast iron or bronze
- **RSD-J** – Features as "J" offset gearbox which allows LH side PTO hookups
- **RSDM** - Available in engine mount





HALE PRODUCTS INC | PH. 800.533.3569 | haleproducts.com



Pressure Relief Valve

Discharge relief valves relief excess pressure to the suction side of the pump. All relief valves include a panel mounted pressure control valve for setting the pressure.

External Relief Valves

- P25 – 2-1/2" Female NPT Relief Valve capable of handling 500 gpm (1893 lpm)
- P30 – 3" Female NPT Relief Valve capable of handling 1000 gpm (3785 lpm)
- P30V – 3" Victaulic Relief Valve capable of handling 1000 gpm (3785 lpm)
- P40 – 4" Victaulic x 3" Female NPT Relief Valve capable of handling 2000 gpm (7570 lpm)
- Dual P40 – Two 4" Victaulic x 3" Female NPT Relief Valves capable of handling 3000 gpm (11,355 lpm)

Internal Relief Valves (Can be ordered with Qmax, Qtwo, and Qflo pumps)

- QD Relief Valves – Capable of handling 1250 gpm (7782 lpm)
- QG Relief Valves – Capable of handling 1750 gpm (6624 lpm)



TPM - Total Pressure Master

Hale's TPM relief valve takes relief valve technology to the next level in a unique dual system design. Discharging excess pressure to the suction side of the pump in normal applications. However, when in use with a hot hydrant or higher intake pressure situations the relief valve will then discharge to the atmosphere providing your pump with appropriate protection regardless of inlet conditions.

- Total Pressure Master monitors and responds to pressure variations on both the suction (inlet) and discharge sides of the pump
- Pump is protected from overpressure regardless of inlet condition
- Provides protection from excess inlet pressure during relay and hydrant operation relieves excess pressure the atmosphere
- Single panel-mounted pressure control valve with easy-to-read pressure reference scale Sets both the external (dump) and internal relief valves



Available options

- Single TPM with P40 Relief valves capable of handling 2000 gpm (7570 lpm)
- Dual TPM with P40 Relief valves is capable of handling 3000 gpm (11,335 lpm)

TRV - Thermal Relief Valve

Hale's Thermal Relief Valve automatically protects your pump from the overheating that may be caused by "dead heading" a pump. Minimizing the need for operator attention to overheating during pumping operations, the TRV 120 automatically dumps a controlled amount of water to atmosphere or back to tank when the pump water temperature exceeds the preset value (120°F/49°C) of the relief valve, and then automatically closes when the water cools. When ordered as a TRV-L 120 it combines the functions of water bypass with a visual warning lamp.

- Relieves water automatically from pump when temperature of the pump water exceeds temperature setting of the valve
- Protects pump by automatically monitoring water temperature
- Resets automatically
- Corrosion resistant design
- Compatible with foam concentrates
- 2" hex x 3-9/16" long with 1-1/4" NPT thread, consumes little pump panel space
- Discharges to atmosphere or to booster tank through 3/8" tubing
- Integrated straining to prevent clogging of the mechanism
- Exceeds NFPA hydrostatic testing requirements
- TRV-L Model includes chrome panel placard with warning lamp and lamp test button. Pre-assembled wiring harness included
- Optional buzzer provides audible warning. Buzzer mounts in 1-1/8" opening on pump panel
- Adapts easily to existing pump discharge openings. Mounts quickly and easily with Hale's four bolt (115) 1-1/4" NPT flange to all Hale manifolded pumps



MIV

Hale's MIV intake valve has all of the standard features you would expect from an intake valve with flows capable up to 2000 gpm (7570 lpm) making it ideal for the most demanding apparatus intake applications. This valve's compact design allows it to be integrated into your Hale pump, behind the panel, saving you valuable panel space and clutter.

- Large diameter NFPA compliant inlet valve that fits behind the panel
- Full Flow Water way design with an oversized 6.4" diameter bore and streamlined butterfly disc allows the valve to be used during annual NFPA testing without loss of performance
- Integral part of the pump normally located between the suction extension and suction tube
- Capable of being mounted in-line for front or rear suction applications
- Corrosion resistant brass construction
- Integrated priming ports allow pre-prime of hard suctions in drafting operations
- Optional manual and electric control



Shift Interlock Module

The shift interlock module integrates innovative Class 1 electronics to Hale's reliable G gearbox. The module exceeds the latest NFPA requirements for NFPA 16.10.1.4 by reducing shifting errors when the apparatus transmission is not safely placed into neutral. Whether shifting into road or pump gear, the interlock module simplifies the integration of shifting into electronic or multiplexed systems. The shift interlock module simplifies installation, increases fire fighter safety by preventing run away truck conditions, and prevents costly equipment damage caused by hot shifts.

- Meets NFPA 1901, 2016 Edition
- Protects transmission from costly damage caused from hot shifting
- Internal delay allows driveshaft to stop in order to minimize miss-shifts
- Can be up fitted to in-service apparatus to bring them up to the latest NFPA 1901 Edition
- Integrated gearbox mount places all the electronics and control close to the gearbox minimizing harness and connection points
- Easy integration into multiplexed electrical systems
- Must specify for use with air control valve or electronic switches



AnodePro

The AnodePro is a device that monitors Intelligent Anodes placed in the pump and signals through the use of an indicator when the anodes should be replaced. This system can be up fitted to a new or used pump and monitors up to three anodes. AnodePro eliminates the guesswork or unnecessary need to check anodes.

- Intelligent monitoring of up to 3 pump anodes
- LED Indicator light illuminates when anodes need replaced
- Retrofittable to existing pumps



Anode

Hale's anodes help prevent damage caused by galvanic corrosion within the pump through the use of a sacrificial metal. This helps to diminish or prevent corrosion of the pump and other critical pump components.

- Provides a sacrificial metal to diminish or prevent unnecessary corrosion
- Three anodes per pump are recommended. One located on the discharge and two on the suction
- Anodes can be mounted in any position
- Standard alloy anode offers 10% better protection than standard zinc anodes
- Optional magnesium anode offers the highest protection for pumps and pump components



ESP (Environmentally Safe Priming) System

The ESP priming system provides the ultimate in fast priming, high vacuum performance and reliability without the use of a lubricant. Technologically advanced and environmentally safe, the ESP's is an oil less, self lubricating rotary vane-type positive displacement primer. Using a single control valve the semiautomatic priming entire system with a single action which simultaneously activates the entire system ensuring fast consistent air evacuation every time.



- Provides fast priming, high vacuum performance and reliability without the use of a lubricant
- Single action control valve which simultaneously activates the entire system ensuring fast consistent air evacuation
- Rotary vane-type positive displacement primer capable of 25 inHg vacuum
- Optional SPV control valve allows single push button priming
- Fully sealed and enclosed motor prevents dust, dirt and water from entering.
- system include: motor/pump unit, ground strap, and control valve are supplied ready for assembly
- Must specify 12-volt or 24-volt DC power when ordering





GODIVA

HALE PRODUCTS INC | PH. 800.533.3569 | haleproducts.com

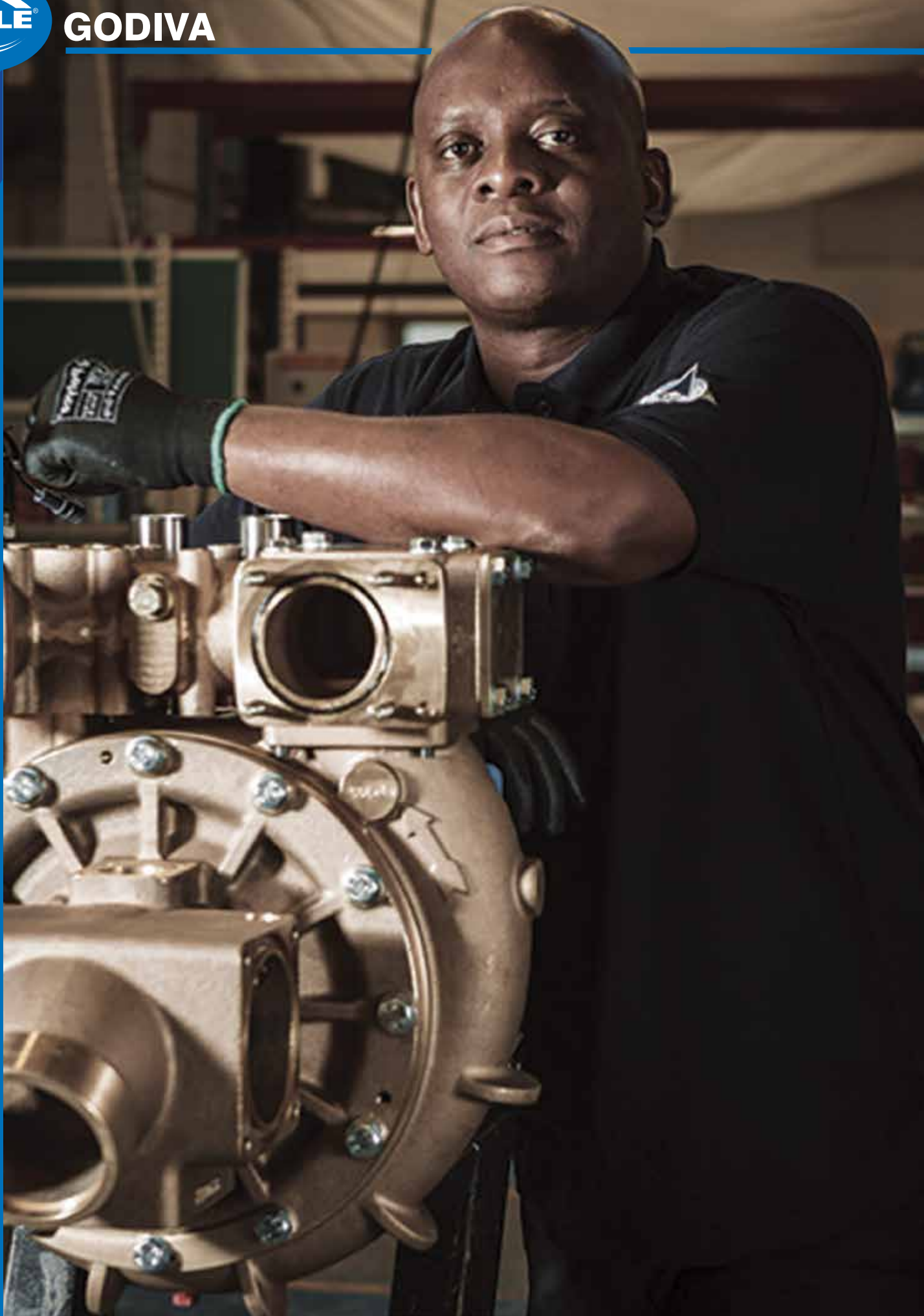

For 80 years Godiva Limited has been supporting the world's firefighters with specialized equipment. With its manufacturing facility in the UK and representative offices and distributors throughout the world, Godiva produces truck mounted and portable fire pumps. Internationally recognized, Godiva fire pumps are found in service in more than 100 countries around the world, where Godiva's decades of experience in fine-tuning products is at the heart of the life-saving business.

Prima P1 Featured

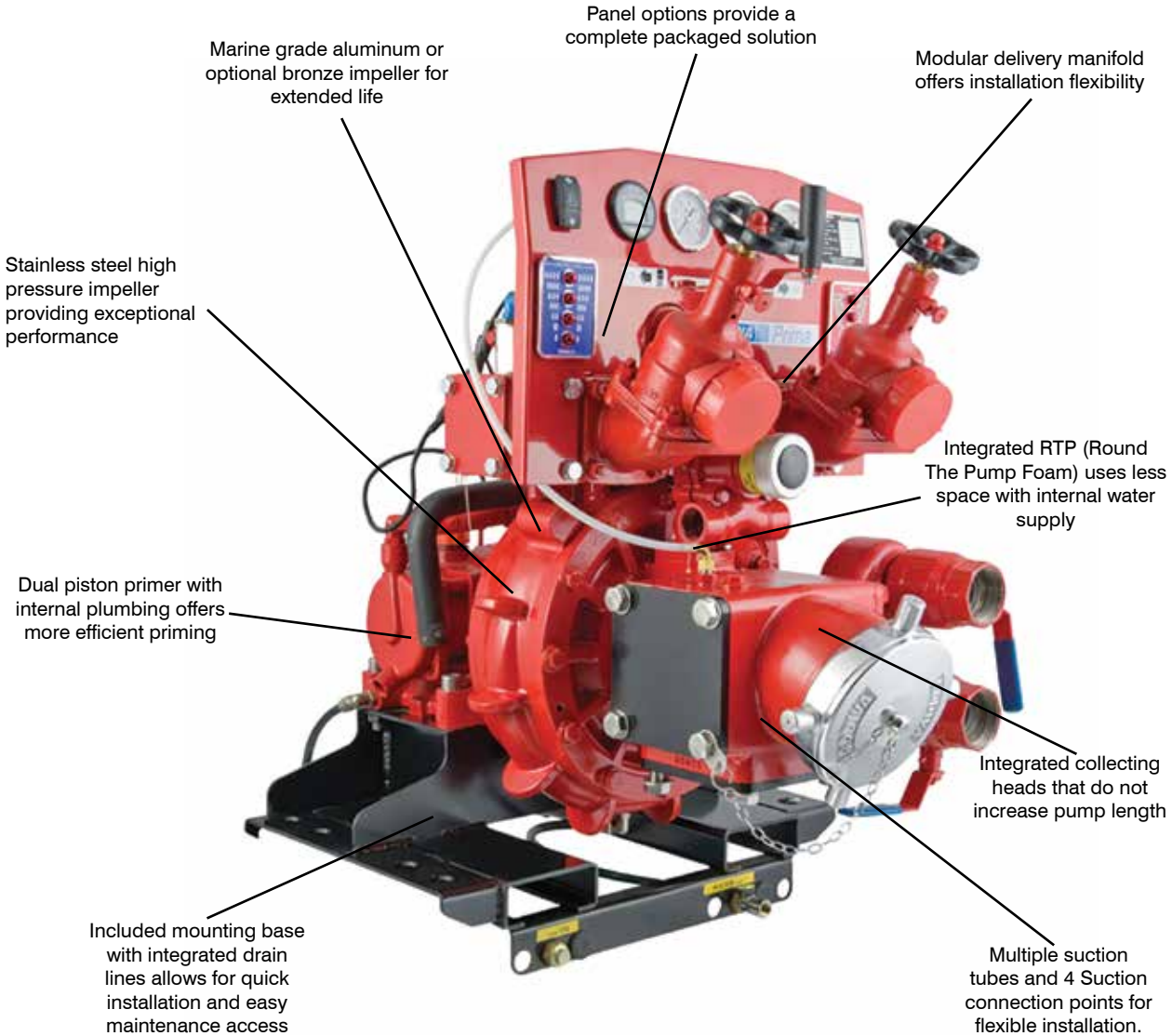

PUMP	RATED FLOW gpm (lpm)	VOLUME gpm (lpm)	STAGE	MATERIAL	DRIVE TYPE
KP1	500 (1900)	-	Single	Light Alloy/Bronze	PTO
KP2	500 (1900)	145 @ 790 psi (250) @ 40 bar	Multi	Light Alloy/Bronze	PTO
PRIMA P2	1500 (5678)	-	Single	Light Alloy/Bronze	Split Shaft
PRIMA P2	1500 (5678)	145 @ 790 psi (550) @ 54 bar	Multi	Light Alloy/Bronze	Split Shaft

KP1/KP2

The KP series of rear or split shaft mounted PTO driven centrifugal fire pumps offers the ultimate in unrivalled performance up to 400 gpm (1500 lpm) because only the KP offers both a single-pressure and a multi-pressure option, reduced whole life cost of ownership, is easily installed and maintained all in the smallest, lightest package in the market.

- Multi pressure KP2 – Can generate high pressure flow up to 145 gpm (550 lpm) with pressures up to 790 psi (54 bar)
- Smaller and Lighter than competitive units
- 5 year maintenance intervals reduces downtime and maintenance costs
- Bench maintainable single piston primer has simple construction for low cost of ownership, with fewer parts
- All maintenance can be performed without disturbing the gearbox and discharge plumbing
- Polymer wear rings, Spring-loaded mechanical seal that are self-adjusting and self-lubricating for minimal maintenance
- Impeller constructed of corrosion resistant anodized aluminum alloy
- Available in engine and opposite engine rotation
- Available in light alloy or bronze

KP1

NFPA Rating: 500 gpm (1900 lpm)
 EN1028: 400 gpm (1500 lpm) @ 150 psi (10 bar)
 Stage: Single



KP2

NFPA Rating: 500 gpm (1900 lpm)
 EN20128: 66 gpm (250 lpm) @ 580 psi (40 bar)
 Pressure Mode: 145 gpm (550 lpm) @ 790 psi (54 bar)
 Stage: Two



Prima P1/Prima P2

The Prima series light alloy pumps were engineered for split shaft and rear mounted applications. Offered in both a single-pressure and a multi-pressure option these pumps were designed utilizing enhanced material selection ensures long life and reliability. Incorporated features aid in maintenance and reduce whole life costs.

- All maintenance can be performed without disturbing the gearbox and discharge plumbing
- Polymer wear rings, Spring-loaded mechanical seal that are self-adjusting and self-lubricating for minimal maintenance
- Impeller constructed of corrosion resistant anodized aluminum alloy.
- Supplied with a ready-to-use mounting platform for ease of installation
- Modular delivery manifold allows for installation flexibility
- Available in engine and opposite engine rotation
- Available in light alloy or bronze

Prima P1

NFPA Rating: 1500 gpm (5678 lpm)
 EN1028: 400 gpm (1500 lpm) @ 150 psi (10 bar)
 Stage: Single

- Single Stage Centrifugal Design



Prima P2

NFPA Rating: 1500 gpm (5678 lpm)
 EN20128: 66 gpm (250 lpm) @ 580 psi (40 bar)
 Multi-Pressure: 145 gpm (550 lpm) @ 790 psi (54 bar)
 Stage: Single

- Multi-pressure design features a centrifugal aluminum low pressure impeller and stainless steel high pressure impeller on a single stainless steel shaft
- Low pressure impeller constructed of corrosion resistant anodized aluminum alloy
- High pressure impeller constructed of stainless steel

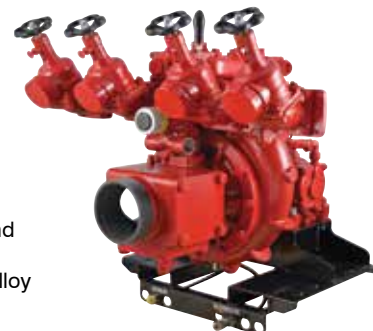





Industrial High Flow

When you need to move a lot of water, you need a high quality pump that is engineered to perform. Hale's range of high flow pumps gives you the capacity you need and the long heritage of designing and manufacturing high performing fire pumps that deliver the reliability you can trust. Count on Hale for the big water flow and performance you demand.

Features:

- Cast one piece volute allows for a small compact design
- Hard, fine grain bronze, mixed flow impeller design is hand ground and balanced for maximum performance
- For minimal maintenance the spring-loaded mechanical seal is self-adjusting and self-lubricating
- Heavy duty precision ground, deep groove bearings used for long-life
- Heat treated one piece stainless steel pump shaft has been designed for strength and to minimize pump deflection
- Bronze clearance rings are easily replaceable
- Available in split shaft or PTO configuration

8FK Featured

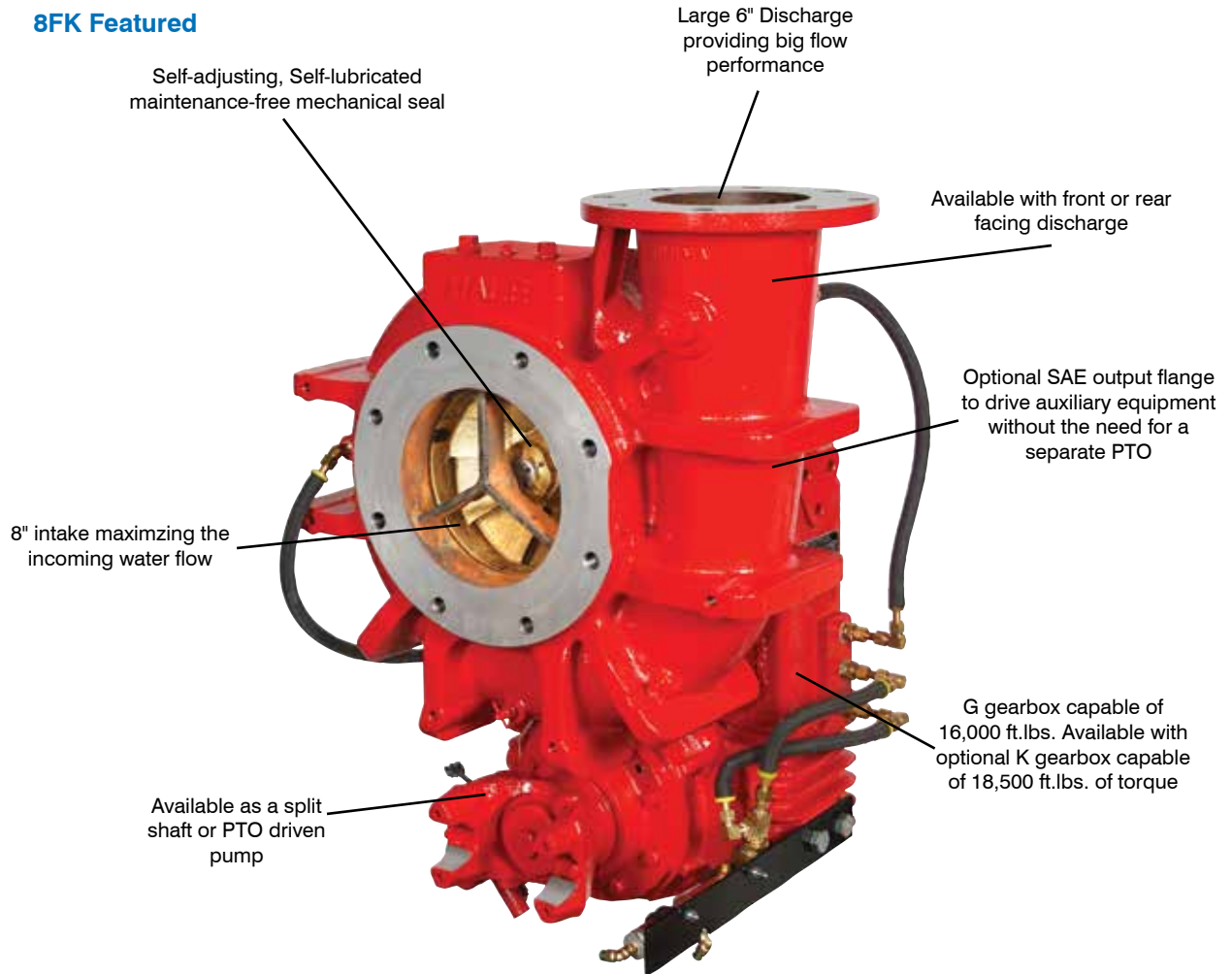

PUMP	RATED FLOW gpm (lpm)	STAGE	MATERIAL	DRIVE TYPE	GEARBOX POSITION
8FKR	3000 (11,355)	Single	Iron or Bronze	Split Shaft, PTO	Front
8FKF	3000 (11,355)	Single	Iron or Bronze	Split Shaft, PTO	Rear
8FGR	3000 (11,355)	Single	Iron or Bronze	Split Shaft, PTO	Front
8FGF	3000 (11,355)	Single	Iron or Bronze	Split Shaft, PTO	Rear
80FC	3000 (11,355)	Single	Iron or Bronze	Engine	
80FCK	3000 (11,355)	Single	Iron or Bronze	Engine	
80FCG	3000 (11,355)	Single	Iron or Bronze	Engine	
RME	3000 (11,355)	Single	Iron or Bronze	PTO	
DFG	6000 (22,712)	Single (Twin Impeller)	Iron or Bronze	Engine, PTO	

8FK

NFPA Rating: 3000 gpm (11,335 lpm)

Stage: Single

Hale's 8FK was designed specifically for high flow industrial firefighting applications. The K gearbox used in the 8FK uses helical gears for strength and quiet operation. Available with a split shaft, PTO, or drive thru gearbox allows the 8FK to be used in many different applications. The compact design requires less space in your truck freeing up valuable space for water, foam, or other equipment.

- Options for 8FKF (Drive Unit Rear) and 8FKR (Drive Unit Front) for design flexibility
- Up to 17,500 lb-ft drive torque rating for high torque engines
- Optional Drive Thru gearbox for marine application where the pump can be operated simultaneously with the propulsion system

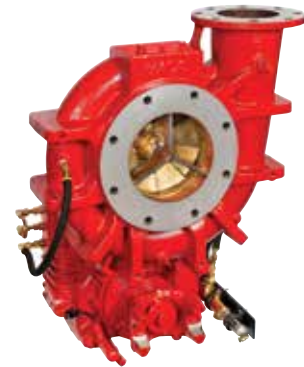

8FG

NFPA Rating: 3000 gpm (11,335 lpm)

Stage: Single

Hale's 8FG was designed specifically for high flow industrial firefighting applications. Built utilizing Hale's most popular G gearbox, the 8FG is manufactured for reliable operation. Available with a split shaft, PTO, or drive thru gearbox allows the 8FG to be used in many different applications. The compact design requires less space in your truck freeing up valuable space for water, foam, or other equipment.

- Options for 8FGF (Drive Unit Rear) and 8FGR (Drive Unit Front) for design flexibility
- Optional Drive Thru gearbox for marine application where the pump can be operated simultaneously with the propulsion system



80FC/80FCG/80FCK

NFPA Rating: up to 3000 gpm (11,335 lpm)

Stage: Single

The 80FC pump is uniquely designed for direct engine mount applications. This cost effective compact pump is ideal for Marine, High Flow Skid and Trailer applications.

- 80FC Direct Mount no gearbox
- 80FCG (G Gearbox) capable of handling 16,000 lb-ft of Torque
- 80FCK (K Gearbox) heavy-duty gearbox capable of handling 18,500 lb-ft of Torque
- available in engine and opposite engine rotation for 80FCG and 80FCK pumps



RME*

NFPA Rating: 3000 gpm (11,335 lpm)

Stage: Single

The RME pump is a direct drive pump designed specifically for rear mount applications and has optional mounting pedestals for ease of installation.



* The RME is a direct drive pump and does not include a gearbox.



Industrial High Flow

DFG

NFPA Rating: 6000 gpm (22,712 lpm)
Stage: Single (Twin Impeller)

The DFG twin impeller, high volume pump is designed and manufactured to meet the demand for big water needs to support industrial and marine applications.

- Dual impellers operate in parallel for a flat performance curve 6000 gpm (22,712 lpm) @ 100 psi (7 bar) or series for high pressure performance 3000 gpm (11,335 lpm) @ 300 psi (21 bar)
- Parallel operations allow high flows while eliminating low flow circulation issues common to larger single impeller pumps
- Highly efficient with a wide range of flows
- Requires pressure-fed lubricating system
- Available with motor mount or PTO-driven
- Available in cast iron or bronze construction

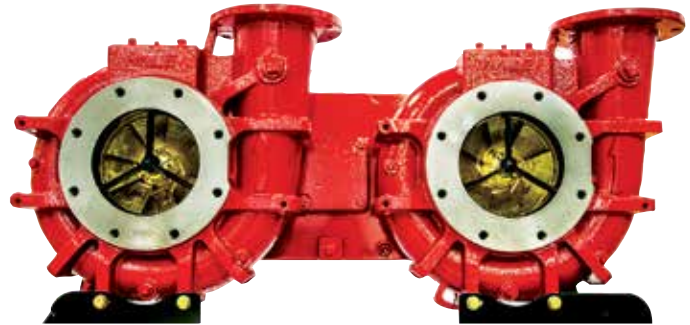



PUMPS





Split Shaft Gearbox

HALE PRODUCTS INC | PH. 800.533.3569 | haleproducts.com



Hale's heavy duty split shaft PTO gearboxes deliver outstanding performance and reliability. Unlike standard general purpose power takeoffs, our gearboxes are uniquely designed to handle the high speed and torque characteristics of emergency vehicle applications. Hardened gears and the industry's most reliable shifting mechanism make Hale gearboxes best in class!

Hale's split shaft PTO gearbox is a practical, cost-effective alternative to using dedicated engines to power pumps, generators, air compressors, and other auxiliary equipment. Installed in a split shaft position between the two halves of a split driveshaft(s), these gearboxes use a sliding gear to shift power between the vehicle's wheels and its own output shaft.

Features:

- Transfer of full engine horsepower to the auxiliary equipment
- Hardened Chrome nickel steel precision gears for extreme durability and reliable performance
- Fewer components for ease of maintenance and simplified rebuilds
- Most reliable shifting transmission in the industry provides that extra piece of mind

MGA

Final Drive Ratios from 1.0:1 to 3.00:1
Output Shaft Torque 625 lb-ft (841 Nm)

- Available with front and rear auxiliary output shafts
- Transfer of full engine horsepower to the auxiliary equipment
- Capable of handling 16,000 lb-ft of torque (21,693 Nm)
- Optional dual auxiliary output shafts for unsurpassed versatility



RGA/LGA

- Output Shaft Torque of 2300 lb-ft (3,118 Nm)
- Transfer of full engine horsepower to the auxiliary equipment
- Capable of handling 16,000 lb-ft of torque (21,693 Nm)
- Most reliable shifting transmission in the industry
- RGA provides rear auxiliary output
- LGA provides front auxiliary output



LKA/XKA

Final Drive Ratios from 1.60:1 to 2.52:1
Output Shaft Torque 2300 lb-ft (3,118 Nm)

- Capable of handling 18,500 lb-ft of torque (25,083 Nm)
- Optional dual auxiliary output shafts for unsurpassed versatility





Special Application

HALE PRODUCTS INC | PH. 800.533.3569 | haleproducts.com



Hale's Engine Driven Units combine a range of diesel engines with our time proven and reliable pumps to exceed your flow, pressure and lift needs. For over a century, Hale Products has been the leader in providing engineered solutions and the technical expertise for Industrial, Municipal and Nuclear emergency water supply applications. Hale offers NFPA 1901 rated performance from 250 gpm (946 lpm) to 5000 gpm (18,927 lpm) with special performance points and higher flows available.

Available in three configurations:

- **Open Chassis:** Skid Unit contains the engine and pump with minimal options
- **Skid Pump:** Unit is a complete ready-to-run package equipped with a onboard fuel tank, control panel, and intake and discharge manifolds
- **Trailer Mounted Pump:** A skid mounted to a trailer (tool boxes, hose racks and hoses as popular options)

Available additionally options include:

- Skid base fuel tank 75, 150 or 200 Gal. (285, 550, or 750 Liters)
- Engine enclosure
- Open exterior frame with lifting points
- Stainless steel manifolds
- Class1® TPG+ engine governor
- Akron Brass valves, scene lighting, and appliances
- Battery system with maintainer



Open Chassis



Skid Configuration



Trailer Configuration

Skid & Trailer Pump and Engine Combinations

UNIT MODEL*	RATED FLOW gpm (lpm)	PUMP	MATERIAL	ENGINE HORSEPOWER
FP500DJ	500 @ 150 psi (1892 @ 10.3 bar)	APSM	Iron or Bronze	99 HP (74 KW)
FP750DJ	750 @ 150 psi (2839 @ 10.3 bar)	RSDM	Iron or Bronze	173 HP (129 KW)
FP1000DJ	1000 @ 150 psi (3785 @ 10.3 bar)	RSDM	Iron or Bronze	200 HP (149 KW)
FP1250DJ	1250 @ 150 psi (4731 @ 10.3 bar)	RSDM	Iron or Bronze	225 HP (168 KW)
FP1500DJ	1500 @ 150 psi (5678 @ 10.3 bar)	RSDM	Iron or Bronze	275 HP (205 KW)
FP2000DJ	2000 @ 150 psi (7570 @ 10.3 bar)	80FCG	Iron or Bronze	350 HP (260 KW)
FP2500DJ	2500 @ 150 psi (9463 @ 10.3 bar)	80FCG	Iron or Bronze	400 HP (298 KW)
FP3000DJ	3000 @ 150 psi (11356 @ 10.3 bar)	80FCK	Iron or Bronze	500 HP (372 KW)
FP5000DJ	5000 @ 100 psi (18,927 @ 6.8 bar)	DFG	Iron or Bronze	600 HP (447 KW)

* Unit models are available in Open Chassis, Skid Pump, or Trailer Mounted configurations



From work boats to yachts, pleasure boats and cruise ships, the outbreak of a fire is about the worst situation one can face at sea. The potential for loss of life, environmental disaster or a threat to valuable cargo and assets is magnified when help can be hundreds or even thousands of miles away. There is no question that marine firefighting presents unique challenges. To overcome these challenges, Hale's marine firefighting pumps are built to perform. Utilizing the highest quality materials and workmanship these rugged pumps deliver flows up to 6000 gpm (22,000 lpm) when you need it. For over a century, Hale Products has been the leader in providing marine solutions that are easily integrated into any of your water supply needs.

See Pages 8-9 and 18-20 for our full range of non-manifolded pumps that can be uses in marine applications.

80FC Duramax Engine Driven Unit

NFPA Rating: 2500 gpm (9463 lpm)

Stage: Single

Marine firefighting applications today are driven by pump performance and space, the 80FC Duramax Marine Engine Driven Unit provides you with both. With a foot print requiring only 38.4 cubic feet of space while offering flows up to 2,500 gpm (9,463 lpm) at 150 psi (10.3 Bar). The Duramax Marine Engine Driven Unit provides more flow in a smaller space by combining our most compact V8 diesel engine with our specifically designed high flow pump.

- Meets Pump Performance for NFPA 1901 or NFPA 1925
- High efficiency centrifugal pumps with flows of:
 - 2000 gpm (7571 lpm)
 - 2250 gpm (8517 lpm)
 - 2500 gpm (9463 lpm)
- Compact design requiring less space
- Hand-ground and balanced bronze impeller
- Vertically split pump design providing ease of access for maintenance
- ASA flange connections - 8" intake and 6" discharge
- Direct engine mount eliminating size and weight of the gear case







Modules

HALE PRODUCTS INC | P.H. 800.533.3569 | haleproducts.com

Hale's Pump modules are a system of critical components that have been pre-engineered to work seamlessly together. All of the components are designed, assembled, and tested as a complete system. Hale's Modules provide you with a worry-free, uninterrupted performance from your pump and related suppression equipment.

Hale modules are an easy-to-order system that allows departments and OEMs to use a single part number linked to a detailed specification with one source of contact for product issues.

- Engineered waterways ensure maximized efficiency and discharge performance.
- CAD designed to ensure that each build is consistent from the first module to the last.
- Hale's standard handle placement promotes consistent build operation procedures across an entire fleet
- All stainless steel plumbing and manifolds for maximum corrosion resistance
- Hale's serial number tracking ensures easy part identification and ordering for maintenance and ordering replacement parts
- Designed to meet NFPA specifications
- Available with Akron Brass valves & appliances



Compact module configurations available down to 24" in width with 1500 gpm capacities.

Hale's Side Kick compact package design allows for maximum space for tank or compartments by moving the pump system below the chassis frame. This frees space above the frame for a full width of the apparatus tank or body design. The added flexibility of this design allows for a lower center of gravity for improved vehicle handling and safety, as well as apparatus compartment space.

The Side Kick is the ideal solution for applications such as:

- Tanker-Pumpers
- Small compact pumpers
- Wet-Side Tankers
- Rural urban interface apparatus
- Rescue pumpers
- Initial attack apparatus

Features:

- All stainless steel plumbing and manifolds for maximum corrosion resistance
- Quick drop out for repairs
- Comes standard with the Class1 TPG, the most advanced and safest pressure governor on the market
- Available with NFPA 1901 500 gpm (1893 lpm) to 1250 gpm (7782 lpm) ratings are available.





Pump Kits

Hale's pump kits are the same system of critical components that have been engineered to work together without the pump module body and panels. All of the components are designed, assembled and tested together as a complete system. Providing you worry-free, performance from your system, while being able to add our own look and feel to the module. Hale's pump kits can be ordered as a pump and manifolding, or with the addition of the following accessories:

- Discharge Valves
- Valve Handles & Controls
- Discharge Gauges
- Drains
- Caps and Plugs
- Pressure Governor
- Tank Level Gauges
- Foam Systems

Qmax Kit



DSD Kit







Electronics

The Class 1 Electronics family of pressure governors, monitor and control your pump's discharge pressure to maintain a desired operating pressure range. With over 30 years in pressure governor development and manufacturing experience, Class 1 Electronics continues to raise the bar and lead the industry in reliable, state of the art, pressure governor technology.

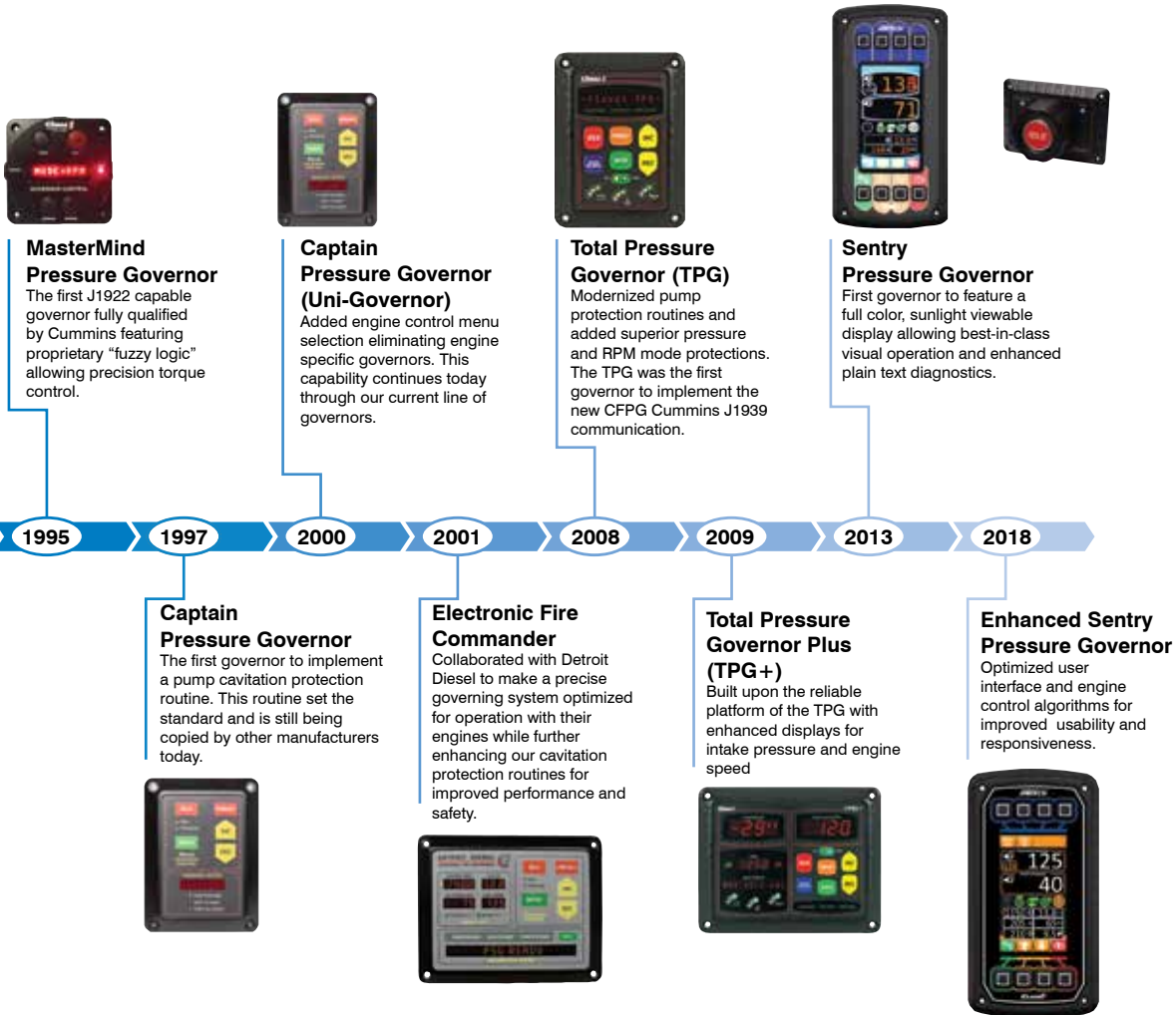

PRODUCT	VOLTAGE RANGE	TEMPERATURE RANGE	ENVIRONMENTAL RANGE	CAN SPECIFICATION
Sentry Pressure Governor	+9VDC to +32VDC	-40 F to +185 F	IP67	SAE J1939 125, 250, 500 Kbits/s
TPG+	+9VDC to +32VDC	-40 F to +185 F	IP67	SAE J1939 125, 250, 500 Kbits/s
TPG	+9VDC to +32VDC	-40 F to +185 F	IP67	SAE J1939 125, 250, 500 Kbits/s
Captain Pressure Governor	+9VDC to +32VDC	-40 F to +185 F	IP67	Analog 0.4V to 4.8V PWM 12% to 87%
Twister	+9VDC to +32VDC	-40 F to +185 F	IP67	SAE J1939 125, 250, 500 Kbits/s
ENFO IV	+9VDC to +32VDC	-40 F to +185 F	IP67	SAE J1939 125, 250, 500 Kbits/s
ENFO III	+9VDC to +32VDC	-40 F to +185 F	IP67	SAE J1939 125, 250, 500 Kbits/s

Sentry Pressure Governor System

Voltage Range: +9VDC to +32VDC

Temperature Range: -40 F to +185 F (-40 C to 85 C)

The Sentry Pressure Governor System provides accurate RPM and pressure functionality while constantly displaying engine speed, oil pressure, coolant temperature, transmission temperature, battery voltage and fuel economy. The Sentry's message center displays warnings as they occur, so the operator can respond quickly. This system can be integrated with the optional Twister for tactile precision adjustment of your engine and pump.

- Fully NFPA compliant
- Direct sunlight visible 4.3" color display
- J1939 CAN or analog engine control
- Optimized control algorithms yield crisp and accurate operation
- Enhanced cavitation protection routines for unmatched performance and safety
- Intake and discharge pressure plus target pressure indication
- Interlock and mode status
- Intuitive operation and service diagnostics
- Multi-language capable
- Dual station control capable
- Available for horizontal or vertical mounting
- Separate display and Twister allow for optimal ergonomic placement of controls
- Screen colors allow for easy identification of operating mode



Optimizing Pump Panel Layouts

The Sentry Governor paired with the Twister Electronic Vernier Throttle:

- Reduces operator fatigue, by optimally placing the Sentry's display at eye level while positioning the twister control knob closer to the waist for easy hand placement
- Simplifies placement on compact pump panels permitting the display & control knob to be located together or separately as needed
- Allows placement options that make this the most flexible & ergonomic governing system available

Total Pressure Governor Plus (TPG+)

Voltage Range: +9VDC to +32VDC

Temperature Range: -40 F to +185 F (-40 C to 85 C)

The Total Pressure Governor Plus (TPG+) places vital pump and engine control information in one easy-to-use compact package. Engine information including oil pressure, temperature, pump hours, fuel rate and engine hours are available. The TPG+ has large intake and discharge pressure displays eliminating the need for separate master gauges saving valuable pump panel space. It utilizes the J1939 CAN bus for engine control but also has an analog throttle output for those engines that do not support CAN control.

- Fully NFPA compliant
- High brightness alphanumeric LED display
- Optimized user controls through the use of large raised buttons
- Dedicated intake and discharge pressure displays
- Optimized control algorithms yield crisp and accurate operation
- Enhanced cavitation protection routines for unmatched performance and safety
- J1939 CAN or analog engine control
- Integrated engine instruments (battery voltage, coolant temperature, oil pressure, and engine RPM)
- Interlock and mode status
- Check engine (CEL) and stop engine (SEL) detection and indicators
- Automatic CAN baud rate detection (125, 250, or 500 Kbits/s)



Total Pressure Governor (TPG)

Voltage Range: +9VDC to +32VDC

Temperature Range: -40 F to +185 F (-40 C to 85 C)

The Total Pressure Governor (TPG) provides tons of features in a compact ergonomically designed package. It is easy to set up and configure. TPG utilizes the J1939 CAN bus for engine control but also has an analog throttle output for those engines that do not support CAN. TPG has an easy to read alpha numeric display and programmable presets. The integrated audible alarm output warns when conditions are out of its normal operating parameters.

- NFPA compliant
- High brightness alphanumeric LED display
- Optimized user controls through the use of large raised buttons
- Optimized control algorithms yield crisp and accurate operation
- J1939 CAN or analog engine control
- Integrated engine instruments (battery voltage, coolant temperature, oil pressure, and engine RPM)
- Provides integral Interlock and mode status
- Automatic CAN baud rate detection (125, 250, or 500 Kbits/s)
- Optimized user controls through the use of large raised buttons



Captain Pressure Governor

Voltage Range: +9VDC to +32VDC

Temperature Range: -40 F to +185 F (-40 C to 85 C)

The Captain Pressure Governor is designed to control the engine ECU to maintain a desired pump pressure or engine speed while displaying key diagnostic information. The "Captain" has a preset button for selecting a predetermined pressure or RPM and an emergency Return to Idle button. The Captain will work with most electronic diesel engines via an electrical control signal to the engine control module.

- Fully NFPA compliant
- High brightness alphanumeric LED display
- Govern pressure or RPM for stationary engine/pump control
- Optimized control algorithms yield crisp and accurate operation
- Provides integral Interlock and mode status
- Presets for RPM and pressure modes
- Programmable for analog or PWM engine control signals



Twister - Electronic Vernier Throttle

Voltage Range: +9VDC to +32VDC

Temperature Range: -40 F to +185 F (-40 C to 85 C)

The Twister has a feature rich compact ergonomic design that is easy to set up and configure. It controls the engine with the J1939 CAN Bus or, for engines that don't support CAN, an analog output. The Twister's unique capabilities enable it to be used as a stand alone throttle control with pressure relief valves or it can integrate with the Sentry Pressure Governor.

- NFPA Compliant
- J1939 CAN or Analog engine Control
- Automatic CAN baud rate detection (125, 250, or 500 Kbits/s)
- Throttle ready or active status indication
- Can be utilized as a stand alone throttle control
- Separate display and Twister allow for optimal ergonomic placement of controls



Matrix™ - Modular Pressure Governor

Voltage Range: +10VDC to +32VDC

Temperature Range: -40 F to +185 F (-40 C to 85 C)

The Matrix governor is the intelligence behind a modular pressure governing system, it packs the entire pump and engine control into a small, fully sealed package. The Matrix governor can be connected to the user interface of your choice like a modern touch screen, UltraView display, Twister, or a simple toggle switch interface. The Matrix governor features advanced algorithms which monitor system conditions to optimize efficiency, reduce operator error, and maximize safety of pump operations.

- Lightning fast response reacts to changes in operating conditions
- Advanced system condition monitoring:
 - Running away from water
 - Cavitation detection
 - Low water or no water conditions
 - Pressure increase when in RPM mode
 - Engine speed and pressure
- Can be controlled from J1939 CAN networked devices or hard-wired switches
- 3 engine control modes available: PGNO, Analog or Cummins Proprietary
- Increase, decrease, idle, mode (pressure or RPM), preset, high idle inputs
- Programmable default mode (pressure, RPM, or none)
- Self-diagnostic options - sends out alarms and warnings when error or fault conditions occur
- Saves and sends pump session data, alarms, fault codes and errors over the CAN data bus
- Advanced settings alarms, units of measure, control ramp rates, stability settings, max pressure settings
- Includes discharge and intake pressure
- Automatic CAN baud rate detection (125, 250, or 500 Kbits/s)



ENFO III (J1939 Engine Bus Information)

Voltage Range: +9VDC to +32VDC
 Temperature Range: -40 F to +185 F (-40 C to 85 C)

The ENFO III is a convenient self contained engine information display for the pump panel operator. Visual and Audible alarms are available for critical information. The ENFO III utilizes the SAE J1587 data link for engine information and the power and ground for the unit provide voltage information.

- High brightness LED displays
- Engine RPM display
- System voltage display
- Engine oil pressure display
- Engine temperature display (oil or coolant)
- Integrated audible alarm
- Meets NFPA 1901 requirements



ENFO IV (J1587 Engine Bus Information)

Voltage Range: +9VDC to +32VDC
 Temperature Range: -40 F to +185 F (-40 C to 85 C)

The ENFO IV is an engine monitoring device that reads and displays: Engine RPM, Engine coolant temperature, and Oil pressure via SAE J1939 CAN messages from the engine Electronic Control Unit (ECU). The ENFO IV also displays vehicle voltage independent of SAE J1939 CAN.

- High brightness LED displays
- Engine RPM display
- System voltage display and alarm
- Engine oil pressure display and alarm
- Engine coolant temperature and alarm
- Meets NFPA 1901 requirements
- Automatic voltage range detection



ITL-40

Voltage Range: +9VDC to +32VDC
 Temperature Range: -40 F to +185 F (-40 C to 85 C)

The ITL-40 Tank Level Indicator accurately displays liquid volume for both water and foam tanks. Each ITL-40 has a super bright LED display easily viewable from 180 degrees with a visual indicator at nine precise levels.

- Level indication easily discernible from a distance at varying angles and lighting conditions.
- Robust system with minimal installation and no scheduled maintenance.
- A wide variety of LED color and label offerings.
- Compatible with other Class1 tank level indicators and driver modules (using serial or C.A.N. communications).
- Similar look to the "Total Pressure Governor" and "TPG Plus" for a cohesive pump panel appearance.
- Unsurpassed diagnostics (using built in "text" based information).
- Custom "Marquee Style" boot sequences available.



ITL-4

Voltage Range: +9VDC to +32VDC
 Temperature Range: -40 F to 185 F (-40 C to 85 C)

The Intelli-Tank™ displays feature wide angle viewing and ultra-bright LED's for high visibility even in direct sunlight. It is very easy to calibrate.





Portable Pumps

When you need to move water, you need a high quality pump that is engineered to perform. Hale's Powerflow range of portable pumps give you the capacity and pressure you need. Whether your application is for high or low pressure fire-fighting, water transfer or de-watering, there is a Hale Powerflow pump for you. Hale has a long heritage of designing and manufacturing high performance fire pumps, so you can trust Hale to deliver the performance you demand.

HPX200-B18 Featured

Powerflow Portables Pumps are available in a wide variety of flow and pressure rated configurations, so you can optimize your pump to meet your needs.

Self-adjusting, self-lubricating mechanical seal for long life and low maintenance

Bronze impeller and clearance rings for excellent corrosion resistance

Single stage bronze impeller delivers high performance and durability as standard

Compact size, yet powerful in performance



Engines you can trust (Briggs & Stratton®, Honda®, & Kubota®). We have carefully chosen our partners who share our passion for performance and durability.

Stainless steel V-Band Clamp design provides quick, easy access for maintenance or repair, and gets your pump back in service with minimum downtime.

Hard-Anodized aluminum pump bodies and volute for low weight and high durability

Built, and tested at our Ocala, FL, USA manufacturing facility

PUMP	RATED FLOW gpm (lpm)	COOLING	FUEL TYPE	WEIGHT DRY	ENGINE	HP (kW)
HPX75-B18	50 @ 250 psi (189 @ 17 bar)	Air Cooled	Gasoline	157	B&S Vanguard 4-Stroke	18 (13.2)
HPX75-YD9**	50 @ 100 psi (189 @ 6.8 bar)	Air Cooled	Diesel	149	Yanmar L100V 4-Stroke	9 (6.6)
HPX75-KBD24	50 @ 250 psi (189 @ 17 bar)	Liquid Cooled	Diesel	353	Kubota D902 4-Stroke	24.8 (18.2)
HPX200-B18	50 @ 150 psi (189 @ 10.3 bar)	Air Cooled	Gasoline	145	B&S Vanguard 4-Stroke	18 (13.2)
HPX200-B23	50 @ 150 psi (189 @ 10.3 bar) 150 @ 100 psi (568 @ 6.8 bar)	Air Cooled	Gasoline	145	B&S Vanguard 4-Stroke	23 (16.9)
HPX200-KBD24	50 @ 150 150 @ 100	Liquid Cooled	Diesel	340	Kubota D902 4-Stroke	24.8 (18.2)
HPX275-B35*	50 @ 150 psi (189 @ 10.3 bar) 150 @ 100 psi (568 @ 6.8 bar)	Air Cooled	Gasoline	190	B&S Vanguard 4-Stroke	35 (25.7)
HPX300-B18	50 @ 100 psi (189 @ 10.3 bar)	Air Cooled	Gasoline	162	B&S Vanguard 4-Stroke	18 (13.2)
HPT300-B18	50 @ 100 psi (189 @ 10.3 bar)	Air Cooled	Gasoline	176	B&S Vanguard 4-Stroke	18 (13.2)
HPX300-KBD24	150 @ 100 psi (568 @ 6.8 bar)	Liquid Cooled	Diesel	340	Kubota D902 4-Stroke	24.8 (18.2)
HPX400-B18	50 @ 100 psi (189 @ 10.3 bar)	Air Cooled	Gasoline	162	B&S Vanguard 4-Stroke	18 (13.2)
HPX450-B35*	150 @ 100 psi (568 @ 6.8 bar)	Air Cooled	Gasoline	190	B&S Vanguard 4-Stroke	35 (25.7)
20FP-C8 Fyr Flote	45 @ 100 psi (170 @ 10.3 bar)	Air Cooled	Gasoline	49	US820 2-Stroke	8 (5.8)
20FV-C8 Fyr Flote	80 @ 75 psi (302 @ 5.1 bar)	Air Cooled	Gasoline	49	US820 2-Stroke	8 (5.8)
20FP-C8P Fyr Pak	45 @ 125 psi (170 @ 8.6 bar)	Air Cooled	Gasoline	34	US820 2-Stroke	8 (5.8)
Super Chief	120 @ 30 psi (454 @ 2 bar)	Air Cooled	Gasoline	118	B&S PowerBuilt 4-Stroke	10.5 (7.7)

Super Chief

NFPA Rating: 120 gpm (454 lpm)
 Flow range: 420 gpm @ 8 psi (1589 lpm @ .5 bar),
 180 gpm @ 25 psi (681 lpm @ 1.7 bar), 90 gpm @ 35 psi (340 lpm @ 2.4 bar)

The Super Chief has a unique design specially engineered for the fire service. The pump and engine assembly detach easily from the float and folds in half for convenient storage in most apparatus compartments. It is easily used with alternative water sources such as streams, lakes, ponds, or pools. The Super Chief requires only three inches of water to draft.



- High volume, floating pump with detachable float for tank filling and water transfer from standing water 3" (76 mm) or more in depth
- Discharge 2.5" (65 mm) male NST hose threaded connection (ISO connection also available)
- Aluminum alloy design with built-in suction guard and skids
- Exclusive auto prime system
- Pump mounted on a high-density polyethylene, unsinkable and removable float for easy compact storage
- Briggs & Stratton PowerBuilt Series 10.5 HP 4-stroke gasoline engine with integrated .75 gal (2.8 L) fuel tank and positive type recoil starter

Fyr Flote

20FV-C8 (Volume)

NFPA Rating: 80 gpm (302 lpm)
 Flow Range: 135 gpm @ 30 psi (511 lpm @ 2 bar),
 80 gpm @ 75 psi (302 lpm @ 5.2 bar), 15 gpm @ 120 psi (56 lpm @ 8.2 bar)

20FP-C8 (Pressure)

NFPA Rating: 50 gpm (189 lpm)
 Flow Range: 65 gpm @ 65 psi (246 lpm @ 4.5 bar),
 45 gpm @ 125 psi (170 lpm @ 8.6 bar), 20 gpm @ 175 psi (75.7 lpm @ 12 bar)



The Fyr Flote is a lightweight, portable centrifugal pump mounted on an unsinkable, high-strength polyethylene float with dual carrying handles and a splash suppression collar. Available in a high-volume model (20FV-C8) and a high-pressure model (20FP-C8) that meets most every pump need in as little as four inches of water. Weighing just 49 lbs. (22 kg), the Fyr Flote stores easily in most truck compartments. It includes an automatic recoil starter, a spark arresting muffler, and an engine over-speed control switch.

- Compact floating pump for tank filling and water transfer from standing water 4" (100 mm) or more in depth
- Discharge 1.5" (38 mm) male NST hose threaded connection
- Aluminum alloy pump body with built-in suction guard
- Bronze impeller with floating renewable wear ring
- Self-adjusting mechanical seal
- Exclusive auto prime system
- Pump mounted on a high-density polyethylene, unsinkable float with dual carrying handles
- U.S. Motor Power US820 8 HP 2-stroke gasoline engine with integrated 1.4 gal (5.3 L) fuel tank

Fyr Pak

NFPA Rating: 45 gpm (170 lpm)
 Flows Range: 65 gpm @ 65 psi (246 lpm @ 4.5 bar), 45 gpm @ 125 psi (170 lpm @ 8.6 bar),
 20 gpm @ 175 psi (75 lpm @ 12 bar)

The Fyr Pak is a lightweight portable centrifugal pump mounted on a padded adjustable backpack frame. Weighing only 34 lbs. (15 kg), the Fyr Pak can pump water from draft, relay, or hydrant. It can go where a fire engine can't. Delivering discharge pressures up to 220 psi (15 bar) and flows up to 75 gpm (285 lpm) from draft, the Fyr Pak is designed to perform. This high performance pump features a automatic recoil starter, a spark arresting muffler, engine overspeed control switch, a priming pump, and a priming valve.



- High pressure backpack pump perfect for back country firefighting
- Light-weight, padded, adjustable backpack frame for easy transport
- 1.5" (38 mm) NST male suction connection; 1.5" NST (38 mm) male discharge connection
- Aluminum alloy pump body
- Bronze impeller with floating renewable wear ring
- Self-adjusting mechanical seal
- Compact, hand operated piston primer
- U.S. Motor Power US820 8 HP 2-stroke gasoline engine



Wildland Firefighting (High Pressure/Low Volume)

haleproducts.com

PH. 800.533.3569

HALE PRODUCTS INC

The Hale range of High Pressure pumps have been designed to deliver the performance you demand, whenever you demand it. We know what it takes to make a durable fire pump, and we take care of the design so you can focus on fighting fires, not your equipment. We achieve high pressure with a single stage high-speed impeller driven by a durable low-maintenance, oil bath gearbox, designed and built by Hale to ensure quality and performance. Multi-stage pumps add bulk and complexity, and complexity means more maintenance. Hale does not use belt-drives because they are less durable and need regular inspection. There may be cheaper ways to build high pressure wildland fire pumps, but there is not a better way.

- High pressure compact unit for chassis and skid mounting (transportable version also available)
- Anodized aluminum alloy pump head and body
- Pump head and body coupled together with stainless steel band clamp for easy serviceability
- Bronze impeller and clearance rings for corrosion resistance
- Self-adjusting, self-lubricating mechanical seal
- 2" (51 mm) NPT suction connection; 1.5" (38 mm) NPT discharge connection
- All engines are equipped with USDA approved spark arrester

HPX75-B18/HPT75-B18

NFPA Rating: 50 gpm (189 lpm)

Flow Range: 15 gpm @ 325 psi (56 lpm @ 22 bar), 70 gpm @ 200 psi (265 lpm @ 13.7 bar), 135 gpm @ 50 psi (511 lpm @ 3.4 bar)

- High pressure compact unit for chassis and skid mounting
- Briggs & Stratton™ Vanguard 18 HP 4-stroke V-Twin gasoline engine
- Electric start with recoil backup
- Exhaust gas primer
- HPT75-B18 - transportable version with carrying handles, 6 gal. (23 L) EPA compliant loose fuel tank, battery and discharge valve



HPX75-YD9 / HPT75-YD9*

NFPA Rating: 50 gpm (189 lpm)

Flow Range: 15 gpm @ 200 psi (56 lpm @ 13.7 bar), 50 gpm @ 140 psi (189 lpm @ 9.6 bar), 100 gpm @ 40 psi (378 lpm @ 2.7 bar)

- Yanmar™ 9 HP L100V 4-stroke diesel engine with integrated 1.24 gal. (4.7 L) fuel tank
- Electric start with recoil backup
- Hand primer
- HPT75-YD9 transportable version with carrying handles, battery and discharge valve



HPX75-KBD24

NFPA Rating: 50 gpm (189 lpm)

Flow Range: 15 gpm @ 350 psi (56 lpm @ 24.1 bar), 70 gpm @ 260 psi (265 lpm @ 18 bar), 145 gpm @ 90 psi (549 lpm @ 6.2 bar)

- Meets the USFS Type 4 and Type 6 apparatus rating of 40 gpm @ 300 psi (151 lpm @ 20.7 bar), 70 gpm @ 250 psi (265 lpm @ 17.2 bar) and 115 gpm @ 150 psi (435 lpm @ 10.3 bar)
- Kubota™ Super Mini Series D902 24.8 HP 4-stroke diesel engine
- EPA Tier 4 emissions compliant
- Electric start
- Oil-less rotary vane electric primer



HPX75-B23

NFPA Rating: 50 gpm (189 lpm)

Flow Range: 15 gpm @ 380 psi (56 lpm @ 26 bar), 80 gpm @ 220 psi (303 lpm @ 15 bar), 150 gpm @ 50 psi (568 lpm @ 3.4 bar)

- Briggs & Stratton Vanguard 23 HP 4-stroke V-Twin gasoline engine
- Electric start
- Exhaust gas primer



* Not for sale or use in U.S. and Canada

Attack Firefighting (Medium Pressure/Medium Volume)

HALE®

PORTABLES

You want flexibility and performance. High quality is your minimum standard. That's why the Hale Attack Firefighting pump range are designed to be tough and perform well at higher or lower pressures. Hale has over 100 years' experience making fire pumps so you can be sure your Hale pump will deliver performance when you need it.

Hale Attack fire pumps are designed and built to meet or exceed applicable performance and safety standards. Hale Attack pumps comply with the revised NFPA 1906 standard, which covers both pump performance and safety aspects.* The revised NFPA 1906 standard is one of the most demanding standards for fire pumps worldwide, and not all manufacturers can comply. Don't compromise – specify a Hale Attack pump.

- Medium pressure, medium flow compact units for chassis and skid mounting (transportable version also available)
- Anodized aluminum alloy pump head and body
- Pump head and body coupled together with stainless steel band clamp for easy serviceability
- Bronze impeller and wear rings for corrosion resistance
- Self-adjusting, self-lubricating mechanical seal
- 3" (25 mm) NPT/4.0" (101 mm) Victaulic suction connection; 2.5" (63 mm) NPT discharge connection
- All engines are equipped with USDA approved spark arrester

HPX200-B18/HPT200-B18

NFPA Rating: 50 gpm (189 lpm)

Flow Range: 70 gpm @ 150 psi (265 lpm @ 10.3 bar), 150 gpm @ 100 psi (568 lpm @ 6.8 bar), 250 gpm @ 30 psi (946 lpm @ 2 bar)

- Briggs & Stratton Vanguard 18 HP 4-stroke V-Twin gasoline engine
- Electric start with recoil backup
- Exhaust gas primer
- HPXT200-B18 - transportable version with carrying handles, 6-gallon EPA compliant loose fuel tank, battery and discharge valve



HPX200-B23

NFPA Rating: 50 gpm (189 lpm)

Flow Range: 90 gpm @ 150 psi (340 lpm @ 10.3 bar), 170 gpm @ 100 psi (643 lpm @ 6.8 bar), 250 gpm @ 30 psi (946 lpm @ 2 bar)

- Briggs & Stratton Vanguard 23 HP 4-stroke V-Twin gasoline engine
- Electric start
- Exhaust gas primer



HPX200-KBD24

NFPA Rating: 150 gpm (567 lpm)

Flow Range: 100 gpm @ 150 psi (378 lpm @ 10.3 bar), 175 gpm @ 100 psi (662 lpm @ 6.8 bar), 250 gpm @ 50 psi (946 lpm @ 3.4 bar)

- Kubota Super Mini Series D902 24.8 HP 4-stroke diesel engine
- EPA Tier 4 emissions compliant
- Electric start
- Oil-less rotary vane electric primer



HPX200-H20

NFPA Rating: 150 gpm (567 lpm)

Flow Range: 70 gpm @ 140 psi (265 lpm @ 9.6 bar), 150 gpm @ 115 psi (568 lpm @ 7.9 bar), 240 gpm @ 40 psi (908 lpm @ 2.7 bar)

- Honda™ GX630 20.8 HP 4-stroke V-Twin gasoline engine
- Electric start
- Hand primer



* Hale Attack pumps with an exhaust gas primer comply with all safety aspects and most but not every performance aspect of the revised NFPA 1906 standard



High Flow (Low Pressure/High Volume)

The Hale range of high-flow pumps have been designed to deliver high volumes of water, without any fuss. With a full range to choose from, there is no need to compromise because Hale can supply a pump optimized for your application. Our high flow pump ends all have single stage impellers directly coupled to high-quality industrial engines, honed over the past 100 years, deliver high-performance. With a Hale pump, you are assured that performance comes as standard.

- Anodized aluminum alloy pump head and body
- Pump head and body coupled together with stainless steel band clamp for easy serviceability
- Bronze impeller and wear rings for corrosion resistance
- Self-adjusting, self-lubricating mechanical seal
- All engines are equipped with USDA approved spark arrester

HPX275-B35*

NFPA Rating: 150 gpm (567 lpm)

Flow Range: 170 gpm @ 150 psi (643 lpm @ 10.3 bar),

250 gpm @ 100 psi (946 lpm @ 6.8 bar), 290 gpm @ 60 psi (1097 lpm @ 4.1 bar)

- Medium pressure, high flow unit for chassis and skid mounting
- 4.0" (101 mm) Victaulic suction connection; 3.0" (76 mm) NPT discharge connection
- Hand primer
- Briggs & Stratton Vanguard 35 HP 4-stroke V-Twin big bore gasoline engine
- Electric start



HPX300-B18 / HPT300-B18

NFPA Rating: 50 gpm (189 lpm)

Flow Range: 120 gpm @ 100 psi (454 lpm @ 6.8 bar),

225 gpm @ 75 psi (851 lpm @ 5.1 bar), 350 gpm @ 40 psi (1324 lpm @ 2.7 bar)

- 3.0" (76 mm) MNST suction connection; 2.5" (63 mm) MNST discharge connection
- Briggs & Stratton Vanguard 18 HP 4-stroke V-Twin gasoline engine
- Electric start with recoil backup
- Exhaust gas primer
- HPT300-B18 - Transportable version with carrying handles, 6-gallon EPA compliant loose fuel tank, battery and discharge valve



HPX300-KBD24

NFPA Rating: 150 gpm (567 lpm)

Flow Range: 190 gpm @ 100 psi (719 lpm @ 6.8 bar),

300 gpm @ 75 psi (1135 lpm @ 5.1 bar), 400 gpm @ 50 psi (1514 lpm @ 3.4 bar)

- Low pressure, high flow unit for chassis and skid mounting
- 3.0" (76 mm) NPT/4.0" (101 mm) Victaulic suction connection; 3.0" (76 mm) NPT discharge connection
- Kubota Super Mini Series D902 24.8 HP 4-stroke diesel engine
- EPA Tier 4 emissions compliant
- Electric start
- Oil-less rotary vane electric primer



HPX400-B18 / HPT400-B18

NFPA Rating: 50 gpm (189 lpm)

Flow Range: 90 gpm @ 100 psi (340 lpm @ 6.8 bar),

330 gpm @ 50 psi (1249 lpm @ 3.4 bar), 500 gpm @ 15 psi (1892 lpm @ 1 bar)

- Low pressure, high flow compact unit for chassis and skid mounting
- 3.0" (76 mm) NPT/4.0" (101 mm) Victaulic suction connection; 3.0" (76 mm) NPT discharge connection
- Briggs & Stratton Vanguard 18 HP 4-stroke V-Twin gasoline engine
- Electric start with recoil backup
- Exhaust gas primer
- HPT400-B18 - transportable version with carrying handles, 6-gallon EPA compliant loose fuel tank, batter and discharge valve



HPX450-B35*

NFPA Rating: 150 gpm (567 lpm)

Flow Range: 250 gpm @ 100 psi (946 lpm @ 6.8 bar),

400 gpm @ 75 psi (1514 lpm @ 5.1 bar), 550 gpm @ 45 psi (2081 lpm @ 3.1 bar)

- Low pressure, high volume unit for chassis and skid mounting
- 4.0" (101 mm) Victaulic suction connection; 3.0" (76 mm) NPT discharge connection
- Briggs & Stratton Vanguard 35 HP 4-stroke V-Twin big bore gasoline engine
- Electric start
- Hand primer



* Not for sale or use in California





SmartFOAM

90% of the today's fires are Class A in nature, often fueled by modern synthetic materials. With flashovers occurring faster than ever, can you afford not to have faster knockdowns, use less water, have fewer rekindles, reduce property damage or improve firefighter safety? Foam is your answer enhancing your firefighting effectiveness, more than plain water.

Over the years Hale has actively educated our customers on the benefits of foam use. Today we continue to pave the way with firefighting foams through a variety of foam proportioning equipment and Compressed Air Foam Systems (CAFS). Hale's SmartFOAM systems utilize flow-based foam proportioning systems with digital controls to make them highly accurate, reliable, and more importantly, simple to use. With the press of one button, SmartFoam eliminates all of the complex problems of traditional foam systems and delivers precise foam for your specific situation. You can count on SmartFOAM for your foam application needs.

SmartFOAM

SmartFOAM is a direct injection foam proportioning system that has been engineered to work smarter for you. Six configurable presets eliminate the need to remember the proper foam injection rate for a specific fire ground scenario. Simply press the preset button with the text indicating your desired scenario. Each preset is fully configurable at the department level so it can be customized for your standard operating procedures.



Eliminates the Guesswork

- One Button Press Operation easily delivers precise foam for every situation
- Six user customizable presets (the system can be manually operated if adjustments are desired)
- Intuitive User interface with best in class color display
- Advanced safety interlocks prevents
 - Mixing of A and B foam types
 - Foam flow while no water is flowing
 - Foam pump will not operate without foam
- Enhanced protection and warnings use plain text alleviating the need to decipher cryptic codes.
- On-screen maintenance reminders
- Full system data logging
- Multilingual language input
- Selectable user interface
- Meets NFPA 1901 & 1906 requirements
- Full range of foam pump options – from 1.7 gpm to 13 gpm
- Capable of controlling two foam pumps

Class A pumps

1.7 and 2.1 gpm

The heart of the SmartFOAM 1.7 gpm and 2.1 gpm systems is an electric motor driven rotary dual piston, plunger pump. The pump is constructed of anodized aluminum and stainless steel and is compatible with most Class "A" foam concentrates. The pump is close coupled to the electric motor thereby eliminating maintenance of an oil filled gearbox. An integrated brass relief valve and strainer protects the foam pump and foam concentrate discharge hoses from over pressurization and unnecessary damage.



Class A and B

3.3, 5.0, and 6.5 gpm

The SmartFOAM 3.3, 5.0, 6.5 , and 13.0 gpm systems utilize an electric motor driven rotary gear pump. The pump is constructed of bronze and stainless steel components and is compatible with almost all foam concentrates. The pump is close coupled to the electric motor thereby eliminating maintenance of an oil-filled gearbox. A integrated stainless steel relief valve protects the foam pump and foam concentrate discharge hoses from over pressurization and unnecessary damage.



SmartFOAM Pump Options							
PART # 12V (24V)	FOAM PUMP	FOAM TYPE	PUMP TYPE	MAXIMUM FOAM FLOW GPM (LPM)	MAXIMUM OPERATING PRESSURE PSI (BAR)	OPERATING CURRENT 12V (24V)	MAXIMUM CURRENT 12V (24V)
119278 (119279)	1.7	A	Dual Plunger	1.7 (6.4)	400 (27.5)	25 (13)	40 (20)
111611 (119612)	2.1	A	Dual Plunger	2.1 (8)	250 (17)	25 (13)	40 (20)
501-3120-62-0 (501-3120-63-0)	3.3	A/B	Rotary Gear	3.3 (12.5)	400 (27.5)	30 (15)	60 (30)
501-3130-62-0 (501-3130-63-0)	5	A/B	Rotary Gear	5 (18)	250 (17)	30 (15)	60 (30)
501-4480-61-0 (501-4480-61-0)	6.5	A/B	Rotary Gear	6.5 (24.6)	200 (13.8)	40 (20)	90 (45)
TBD	Dual 6.5	A/B	Rotary Gear	13 (49.2)	200 (13.8)	80 (40)	180 (90)

INJECTION RATE PERCENTAGE %	MAXIMUM FOAM SOLUTION GPM (LPM)					
	AVAILABLE FOAM PUMP OPTIONS					
	1.7	2.1	3.3	5.0	6.5	Dual 6.5
0.1	1700 (6435)	2100 (7949)	3300 (12,491)	5000 (18,927)	6500 (24,605)	13,000 (49,210)
0.2	850 (3217)	1050 (3974)	1650 (6245)	2500 (9463)	3250 (12,302)	6500 (24,605)
0.3	567 (2146)	700 (2649)	1100 (4163)	1667 (6310)	2167 (8202)	4333 (16,402)
0.5	40 (151)	420 (1589)	660 (2498)	1000 (3785)	1300 (4921)	2600 (9842)
1.0	170 (643)	210 (794)	330 (1249)	500 (1892)	650 (2460)	1300 (4921)
3.0	-	-	110 (416)	167 (632)	217 (821)	433 (1639)
6.0	-	-	55 (208)	83 (314)	108 (408)	217 (821)



SmartCAFS

SmartCAFS is a Compressed Air Foam System that works smarter for you. Use of a Compressed Air Foam System has traditionally been a complex and daunting task with many sequentially specialized steps. Successfully balancing the water pump, foam system, and air system so they work effectively together can be downright frustrating. The days of intimidating CAFS are over.

SmartCAFS executes all of these functions for you and completely simplifies the CAFS procedure. The fully programmable presets allow your department to set CAFS configurations for numerous fire scenarios, taking the guesswork out of setup allowing you to focus on fighting fire.



- One Button Press Operation eliminates the guesswork and easily delivers precise compressed air foam for every situation
- Ten user customizable presets
- Intuitive user interface with best in class color display
- Full range of CAFS from wet (1:3) to dry (1:20)
- Seamlessly interacts with sentry pressure governor
- Advanced safety interlocks prevents:
 - Air injection when foam and water are not flowing
 - Engagement that could cause air compressor clutch damage
- Prevents mixing of A and B foam types
- On screen maintenance reminders
- Full system data logging
- Multilingual language input
- Reliable twin screw rotary compressor



SmartCAFS Pump Options							
PART # 12V (24V)	FOAM PUMP DESCRIPTION	FOAM TYPE	PUMP TYPE	MAXIMUM FOAM FLOW GPM (LPM)	MAXIMUM OPERATING PRESSURE PSI (BAR)	OPERATING CURRENT 12V (24V)	MAXIMUM CURRENT 12V (24V)
501-3120-62-0 (501-6120-63-0)	3.3	A/B	Rotary Gear	3.3 (12.5)	400 (27.5)	30 (15)	60 (30)
501-3130-62-0 (501-3130-63-0)	5	A/B	Rotary Gear	5 (18)	250 (17)	30 (15)	60 (30)
501-4480-62-0	6.5	A/B	Rotary Gear	6.5 (24.6)	200 (13.8)	40 (20)	90 (45)
TBD	Dual 6.5	A/B	Rotary Gear	13 (49.2)	200 (13.8)		

INJECTION RATE PERCENTAGE %	MAXIMUM FOAM SOLUTION GPM (LPM)					
	AVAILABLE FOAM PUMP OPTIONS					
	1.7	2.1	3.3	5.0	6.5	Dual 6.5
0.1	1700 (6435)	2100 (7949)	3300 (12,491)	5000 (18,927)	6500 (24,605)	13,000 (49,210)
0.2	850 (3217)	1050 (3974)	1650 (6245)	2500 (9463)	3250 (12,302)	6500 (24,605)
0.3	567 (2146)	700 (2649)	1100 (4163)	1667 (6310)	2167 (8202)	4333 (16,402)
0.5	40 (151)	420 (1589)	660 (2498)	1000 (3785)	1300 (4921)	2600 (9842)
1.0	170 (643)	210 (794)	330 (1249)	500 (1892)	650 (2460)	1300 (4921)
3.0	-	-	110 (416)	167 (632)	217 (821)	433 (1639)
6.0	-	-	55 (208)	83 (314)	108 (408)	217 (821)

SmartCAFS Pump Compatibility						
SMARTCAFS SYSTEM	COMPATIBLE PUMP	WATER FLOW	NORMAL AIR FLOW CFM	AIR RATIO RANGE	AIR OPERATING PRESSURE PSI (BAR)	WATER OPERATING PRESSURE PSI (BAR)
					MAXIMUM	MAXIMUM
210 CFM for Single Stage	Qmax, Qmax-XS, or DSD	1000-2250 (3785-8515)	210	1:3 (wet) to 1:20 (dry)	150 (10)	150 (10)
210 CFM for Two Stage	Qtwo	1000-2000 (3785-7570)	210	1:3 (wet) to 1:20 (dry)	150 (10)	150 (10)
Prima 2010	P1 - Single Stage P2 - Multistage	P1 - 897 (3395) P2 - 203 (768)	50, 100, or 200*	1:3 (wet) to 1:20 (dry)	145 (9.9)	P1 - 247 P2 - 790
Prima 3010	P1 - Single Stage P2 - Multistage	P1 - 1109 (4198) P2 - 203 (768)	50, 100, or 200*	1:3 (wet) to 1:20 (dry)	145 (9.9)	P1 - 247 P2 - 790
Prima 4010	P1 - Single Stage P2 - Multistage	P1 - 1638 (6200) P2 - 203 (768)	50, 100, or 200*	1:3 (wet) to 1:20 (dry)	145 (9.9)	P1 - 247 P2 - 790
Prima 6010	P1 - Single Stage P2 - Multistage	P1 - 2200 (8327) P2 - 203 (768)	50, 100, or 200*	1:3 (wet) to 1:20 (dry)	145 (9.9)	P1 - 247 P2 - 790

*Must specify compressor size at time of order for Prima systems





SmartATP

SmartATP is an automated around the pump foam proportioning system available in either 125 or 225 gpm (473 or 851 lpm) configurations. This proportioning system operates by using the discharge from the pump to draw foam into the suction side of the pump. Unlike traditional manual systems, the SmartATP automatically regulates the foam ratio control valve electronically through a fully sealed color LCD user interface display, eliminating the opportunities for operator error and wasted foam. As an added benefit, the display provides additional critical feedback such as water flow, foam flow, discharge pressure, intake pressure, foam tank level, total foam flowed and total water flowed. The SmartATP also features an automated flush preventing unwanted mixing of Class A and B foams when switching foam types. Hale's SmartATP Foam System makes high flow foam use easy, delivering precise foam for every situation.



Eliminates the Guesswork

- One Button Press Operation easily delivers precise foam for every situation
- Integrated tutorials makes calibration and other programming easy to use
- Auto-Flush capability automatically flushes system when switching foam types
- Plain text messaging provide operators with critical information, diagnostics, or system errors
- AutoFill capable: allows intake connection from a pressurized source which then maintains a consistent water tank level automatically without water hammer
- Optional Dual Tank installation kit allowing both A and B foam
- OEM installation kits includes the necessary valves, solenoids, and couplings for installation
- Available fully assembled with a new Hale pump or as an independent kit
- Ability to adjust foam ratio from 0.1% to 10%
- Available at maximum foam flow capacities of either 125 gpm (473 lpm) or 225 gpm (851 lpm)
- In excess of 3500 gpm of 6% Foam and Water solution at 150 Psi (10 bar)
- Multilingual language input

See page 89 for SmartATP system layout



EZ-Fill® Foam Reservoir Refill System

EZ-Fill is an easy-to-operate fixed-mount 12 or 24 volt 5 gpm foam tank refill system. EZ-Fill features push-button smart-switch technology. Just press the “Fill” or “Flush” button and the unit will operate either by filling the foam concentrate reservoir or running through a flush cycle. The unit is self-priming and will automatically shut off after 60 seconds or when the foam concentrate reservoir is full. The system can be ordered for either a single or dual tank foam concentrate reservoir system.



- Safe efficient way to refill your apparatus foam tank from the pump operators panel
- Electronic three-way valve switches the system from “Fill” to the “Flush” function and back again.
- Cam-lock quick connect suction hose designed for foam pail drafting operations
- Suction hose is equipped with integral strainer to prevent intake of unwanted debris
- Supplied wiring harness for easy installation
- Configurations include dual foam concentrate reservoir refill for Class “A” and “B” foams
- Compact Smart-Switch panel control
- Push button control Smart-Switch automatically stops foam pump after 60 seconds or when the foam reservoir is full

Manual Single Tank Selector (MST)

Single tank SmartFOAM and SmartCAFS systems can be configured with a Manual Single Tank (MST) selector, panel mounted flush control. The MST is panel mounted for easy access so the operator doesn't need to leave the panel.



Manual Dual Tank Selector (MDTII)

The Manual Dual Tank (MDT II) selector valve is available for the SmartFOAM and SmartCAFS systems with dual tanks. The MDT II is a panel mounted, manually operated selector that provides selection of foam concentrate dependent on fire ground operational demands. The MDT II also provides an electrical interlock for the low tank level sensors and concentrate injection rate. This unit not suitable for top mount operator panel installations and some side operator panels due to gravity feed requirements of foam concentrate to the foam pump.



Air Dual Tank Selector (ADT)

The Air Dual Tank (ADT) valve is an air operated foam tank selector valve that enables selection of foam concentrate dependent on fire ground operational demands. The ADT is an integral part of the foam pump and provides an electrical interlock for the low tank level sensors and concentrate injection rate. A panel mounted selector toggle switch with indicator lights controls foam concentrate tank selection and identifies which foam concentrate tank is in use.



Fill Thief

The Fill Thief bolts directly on the inlet of the Hale Master Intake Valve (MIV) and simplifies manifolded pump water supply management. The Fill Thief is an accessory built specifically for users purchasing a manifolded pump and Compressed Air Foam System combination. When a large diameter hose (LDH) is connected to the Fill Thief inlet and the MIV is in the "closed" position, the incoming water is directed to a direct tank fill valve. This direct tank fill can either be a "manual" valve or a Hale Auto Fill.



- Eliminates the need to have a secondary supply line not connected to intake plumbing
- Requires the Hale Master Intake Valve (MIV) for installation and operation.

AutoFill - Automatic Direct Booster Tank Fill System

Autofill is an automated tank refill system designed to keep the apparatus' water tank at a set level without the need for operator intervention. It is a highly recommended option when purchasing a SmartCAFS manifolded or rear mount system. The AutoFill is integrated into the SmartCAFS display and works in conjunction with the water Intelli-Tank Level (ITL) display automatically maintains the desired booster tank's water level with an appropriate water supply. The automatic operation of the AutoFill system simplifies the pump operators role, enabling focus on other critical operations.



- Automatically maintains a desired tank level
- Two operation modes Automatic and manual.
- Integrated inlet pressure relief valve
- Positive inlet pressure detection safeguards, the system from being opened and allowing the booster tank to drain when connected to a water supply
- Available in 2-1/2" (64 mm) or 3" (76 mm) valve options.

Low Pressure Strainer

The low pressure foam concentrate strainer is designed to be mounted at the inlet of the foam pump. The strainer protects the foam pump from debris that might accumulate in the foam concentrate tank.

- Composite design with a stainless steel strainer and a service shut-off valve
- Offers 1/2" NPT (13 mm) threads, with a fitting to connect a 1/2" (13 mm) ID foam concentrate suction hose
- Not designed for installations where subject to HIGH pressure flushing water



High Pressure Strainer

Hale's FS series strainers (FS15 and FS25) are panel mounted with a 500 PSI (34 BAR) pressure rating suitable for use where flushing water pressure must pass through the strainer.

- It is suitable for use with both Class "A" and Class "B" foam concentrates
- FS15 - features 3/4" (19mm) NPT ports and a 1-1/2" (38 mm) NST connection
- FS25 - features 1" (25 mm) NPT ports and a 2-1/2" (63.5 mm) NST connection



**Note: The Fill Thief fitting extends beyond standard pump house enclosures. On typical installations, the pump panel enclosure is notched and the Fill Thief fitting is exposed.*





Gauges

HALE PRODUCTS INC | PH. 800.533.3569 | haleproducts.com

Hale Products is the leading manufacturer of gauges that exceed the rigorous demands of fire service professionals. Thousands trust our freeze proof pressure gauges that are currently in service and meet or exceed NFPA and ANSI standards.

All our Interlube filled pressure gauges with Sub-Z freeze-proof isolators are a must for fire apparatus. The Sub-Z's uniquely designed stem and bourdon tube are filled and sealed with a low temperature liquid. This eliminates water from entering the tube, preventing freezing and subsequent damage to the gauge. The Interlube fill fluid in the case dampens pulsations and vibration, eliminating the need for snubber valves and the potential for fogged lenses.

The demands of firefighting professionals for accurate and reliable instrument readings have been met by thousands of our gauges currently in service. Demand Hale Products gauges on your next apparatus.

Features:

- Sub-Z II freeze-proof isolator, preventing water from entering the tube eliminating freezing and subsequent damage to the gauge
- Internal Breathing Diaphragm eliminates the need for an air bubble and provide distortion free viewing
- Durable Zytel constructed case in 2.5" to 4.5" Gauges (6" gauge aluminum)
- Accuracy
 - 2.5" gauge +/- 2% mid-scale; +/-3% balance, ANSI B40.1, Grade B
 - 3.5", 4.5" and 6" gauge +/-1% of full scale, ANSI B40.1, Grade 1A
- Gauges are rated from -40o to 150o F (-40o to 65o C)
- Meet or exceeds NFPA and ANSI standards
- Customized Logo Dials available

See page 55 for part numbers and ordering information.

Available in 2.5", 3.5" 4.5" & 6" Sizes

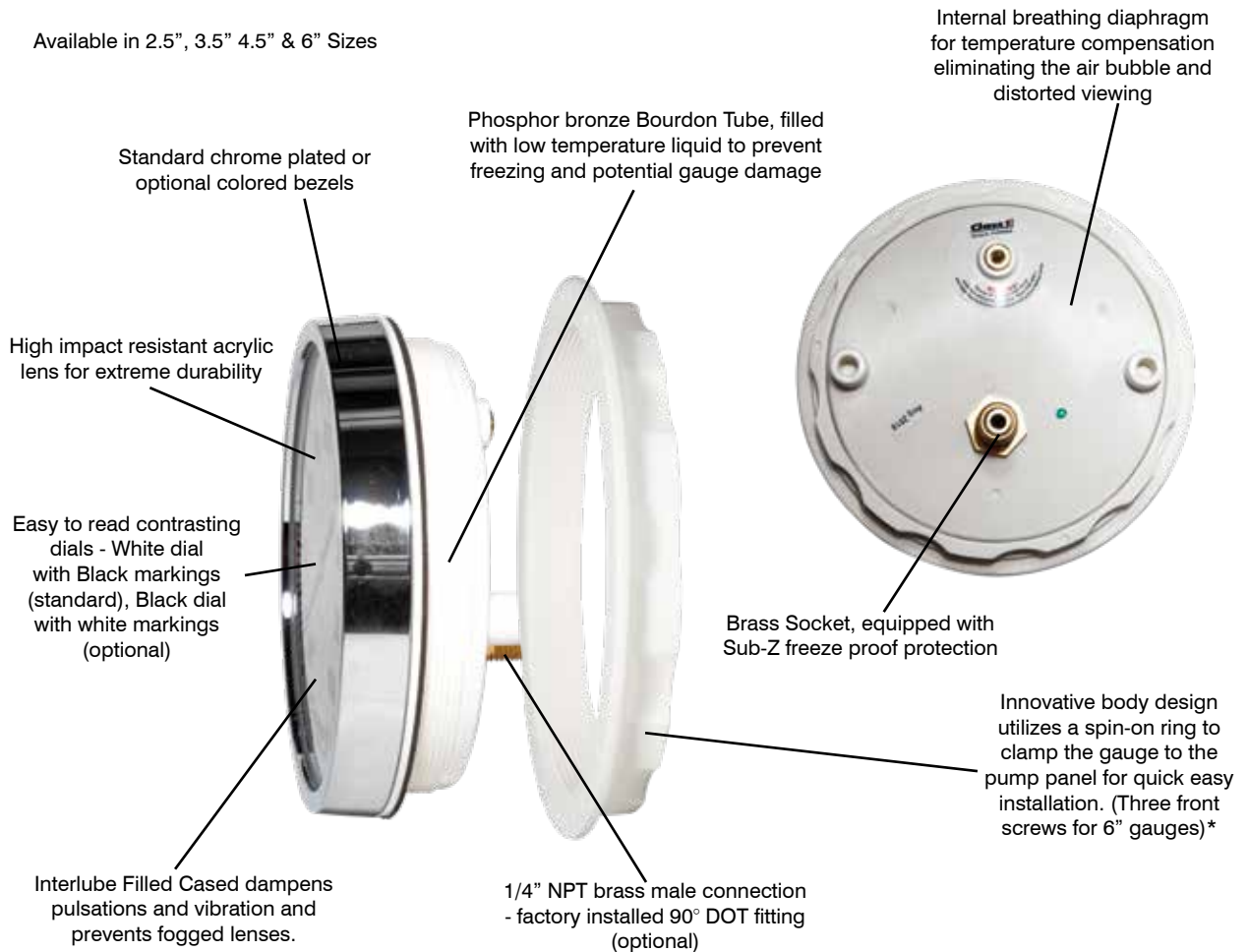

Meet or exceeds NFPA and ANSI standards

*Our body design will also work if you need to replace an existing gauge. The hole cut outs are standard sizes.

Lighted Pressure Gauges

Class1's series of liquid filled backlit pressure gauges use LEDs to light the liquid-filled gauges.

The gauge case has been upgraded to isolate the LED light from the gauge. LED lights are independent of the gauge allowing for interchangeability color selection and easy field replacement.

Features

- Brightly lit by LED's for heightened visibility
- Colors available in red, green, blue, yellow and white
- Vivid illumination increases visibility under extreme incident conditions
- Available in both 12 and 24 Volt
- Single and dual LED assemblies available
- LED assemblies sold separate from gauges

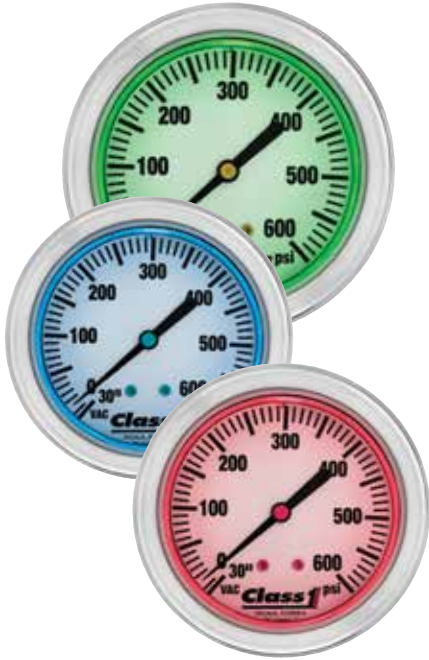

LED Light Assembly Ordering Information

1. Select either a Single or Dual LED Assembly configuration
 - Single LED Assembly Part Number: 122185-XXX
 - Dual LED Assembly Part Number: 122186-XXX
2. Add the appropriate 3 digit code for voltage and color (from the chart below) in place of the "XXX"

Note: When ordering please specify the appropriate quantity of LED assemblies for adequate illumination of your gauge.

- 2.5, 3.5, & 4.5" Gauges require 2 Single LED Assemblies or 1 Dual LED assembly.
- 6" Gauges require 4 single LED assemblies or 2 Dual LED assemblies

3 DIGIT CODE	VOLTAGE (DC)	LED COLOR	POWER WIRE COLOR
001	12V	RED	RED
002	12V	GREEN	GREEN
003	12V	YELLOW	YELLOW
004	12V	BLUE	BLUE
005	12V	WHITE	WHITE
021	24V	RED	RED
022	24V	GREEN	GREEN
023	24V	YELLOW	YELLOW
024	24V	BLUE	BLUE
025	24V	WHITE	WHITE

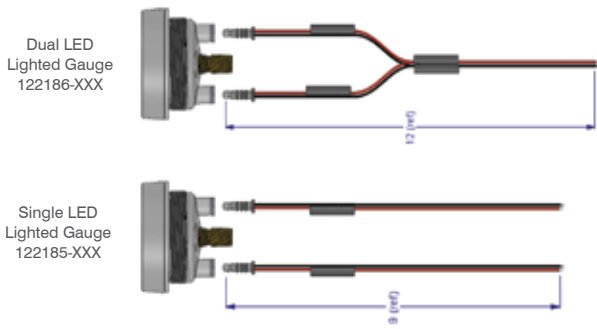

4.5" Duplex Gauges

Duplex gauges should be used when two different pressures need to be monitored on a single gauge such as balanced pressure foam systems or Class "A" foam systems with both air and water pressures.

Features

- Chrome Bezel
- Dual Bronze Sockets equipped with Sub-Z II freeze protection
- (2) 1/4" male NPT connections on the lower back, side-by-side
- Dial color is white with black markings
- Pointers 1 red and 1 black
- Accuracy + 2% of scale
- Available in 0-400psi or 0-600psi ranges



2.5" Colored Bezels

Class1 colored bezels are powder coated and made of stainless steel. This coating provides superior durability and corrosion protection. Colored bezels are available in 12 colors on our premium 2.5" and 3.5" gauge styles.

(Note: Bezels are not installed and must be ordered separately)

Available colors:

- Black (BLK) • Gray (GRY) • Orange (ORG) • Silver (SIL)
- Blue (BLU) • Green (GRN) • Purple (PUR) • White (WHT)
- Brown (BRN) • Lime (LIM) • Red (RED) • Yellow (YLW)

Part Number 115820-XXX (XXX = the desired three digit color code from the available color list above)



Chrome Plated Gauge Bezels

Class1 color coded chrome bezels are available for the 2.5" and 3.5" Premium Liquid Filled Gauges, Lighted Gauges and Digital Displays.

Description	Part #
2.5" Chrome Plated Bezels	105548
3.5" Chrome Plated Bezels	105546

Contact Customer Service for corner tag colors and part numbers.



QC TEST KIT

Check your panel gauge accuracy with our handy QC Test Kit. The kit comes complete with everything you need to easily perform the test right in the station or during your annual pump test.

The kit includes Class1 pressure and vacuum gauges, flexible high pressure hoses with fittings and a carrying case. To certify accuracy, the gauges are shipped with a certificate of calibration at 1%, 300# gauge with 2# increments (recommended for NFPA pump tests).

Specifications

- Gauges: One 0-30" vacuum and one 0-300 PSI gauge (in 2 PSI increments) 0-400 gauge also available
- Dial: 3.5" white with black markings
- Accuracy: +/- 1% of full scale, ANSI B40.1, Grade 1A
- Mounting Plate: Black anodized aluminum 0.125" thick
- Hoses: Two - 36" each
- Hose connections: 1/4" NPT male
- Carrying Case: ABS plastic, 15.5" x 11" x 4.5" (394mm x279mm 114mm)



Gauge Ordering Information

Our goal is to assist you in ordering the correct gauge the first time and every time. By following the guidelines below you can quickly and easily find the part number required.

1. Determine the size required.
2. Select the appropriate pressure range and unit of measure.
3. Determine the dial color.
4. This will lead Direct you to the appropriate base gauge part number.
5. Add a “-F” to the end of the part number if you require the optional 90° push on fitting.
6. Add a “-L” to the end of the part number for gauges that are capable of being fitted with LED light assemblies.

(LED Assemblies are sold separately. See page 53 for LED assembly ordering information)

PRESSURE RANGE	DIAL COLOR*	BASE PART #	ADD 90° FITTING	LIGHT COMPATIBLE
60mm Gauges				
0-400 PSI	WHITE	91220001	-F	N/A
2.5" Gauges				
0-300-PSI	WHITE	91525875	-F	-L
0-400-PSI	WHITE	91523971	-F	-L
0-400-PSI	BLACK	91523970	-F	N/A
30-0-400-PSI	WHITE	91523932	-F	-L
30-0-400-PSI	BLACK	91523936	-F	N/A
0-600-PSI	WHITE	91523934	-F	-L
0-600-PSI	BLACK	91523938	-F	N/A
30-0-600-PSI	BLACK	91523938	-F	-L
30-0-600-PSI	BLACK	91523937	-F	N/A
0-400-PSI/KPA	WHITE	91525862	-F	-L
30-0-400-PSI/KPA	WHITE	91529546	-F	-L
0-600-PSI/KPA	WHITE	91525931	-F	-L
30-0-600-PSI/KPA	WHITE	91525974	-F	-L
3.5" Gauges				
0-300-PSI	WHITE	91556688	-F	-L
0-400-PSI	WHITE	91553951	-F	-L
0-400-PSI	BLACK	91553947	-F	N/A
30-0-400-PSI	WHITE	91553940	-F	-L
30-0-400-PSI	BLACK	91553948	-F	N/A
0-600-PSI	WHITE	91553943	-F	-L
0-600-PSI	BLACK	91553950	-F	N/A
30-0-600-PSI	WHITE	91553941	-F	-L
30-0600-PSI	BLACK	91553945	-F	N/A
0-400-PSI/KPA	WHITE	91555863	-F	-L
30-0400-PSI/KPA	WHITE	92550727	-F	-L
0-600-PSI/KPA	WHITE	93550149	-F	-L
30-0-600-PSI/KPA	WHITE	91555978	-F	-L

* WHITE = white dial with black lettering, BLACK = black dial with white lettering

Gauge Size Reference Dimensions

GAUGE SIZE	DIAL	OD
2.5" GAUGE	2.5" (65mm)	3.2" (81mm)
3.5" GAUGE	3.5" (89mm)	4.125" (105mm)
4.5" GAUGE	4.5" (114mm)	5.25" (133mm)

Example 1:

Base Part #	With Fitting	Light Compatible
9152587	-F	-L

 = 9152587-F-L

Example 2:

Base Gauge Part #	With Fitting	Backlight Configured
91556688		-L

 = 91556688-L

PRESSURE RANGE	DIAL COLOR*	BASE PART #	ADD 90° FITTING	LIGHT COMPATIBLE
4.5" Gauges				
0-400-PSI	WHITE	91583962	-F	-L
0-400-PSI	BLACK	91583959	-F	N/A
30-0-400-PSI	WHITE	91583952	-F	-L
30-0-400-PSI	BLACK	91583960	-F	N/A
0-600-PSI	WHITE	91583954	-F	-L
0-600-PSI	BLACK	91583961	-F	N/A
30-0-600-PSI	WHITE	91583953	-F	-L
30-0-600-PSI	BLACK	91583956	-F	N/A
0-400-PSI/KPA	WHITE	91582326	-F	-L
30-0-400-PSI/KPA	WHITE	91586215	-F	-L
30-0-600-PSI/KPA	WHITE	91585860	-F	-L
6" Gauges				
30-0-400-PSI	WHITE	1664721	-F	-L
30-0-400-PSI	BLACK	93660049	-F	N/A
30-0-600-PSI	WHITE	91663964	-F	-L
30-0-600-PSI	BLACK	91663966	-F	N/A
Duplex Gauges				
0-400-PSI	WHITE	32751484	-F	-L
0-400-PSI/KPA	WHITE	32751487	-F	-L
0-600-PSI	WHITE	32751485	-F	-L
0-600-PSI/KPA	WHITE	32751422	-F	-L

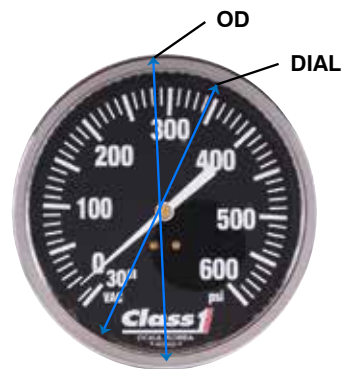

2.5" Gauge 1-300psi with a white dial, and push on brass fitting capable of having LED Backlighting Assemblies installed.

3.5" Gauge 1-300psi with a white dial, no fitting and capable of having LED Backlighting Assemblies installed

Contact Customer Service for additional questions.



Plumbing

Hale offers a wide variety of plumbing components to make the pump installation and operation easier for the OEM and End User. Hale controls allow for a clean and compact pump panel. Controls can be clearly marked for valve identification. With the many drain valves available, we can fulfill and possible. Hale's stainless piping and manifold components allow for minimal friction loss along with cleaner pump house construction.



Locking Top Mount Control

The locking Top Mount Control allows for a more compact and cleaner pump panel while reducing installation time and material cost.

- Lock in any position
- No slots in the pump panel (eliminates road grime buildup)
- Integrated pump panel hinge
- Recessed area in handle for round ID tag

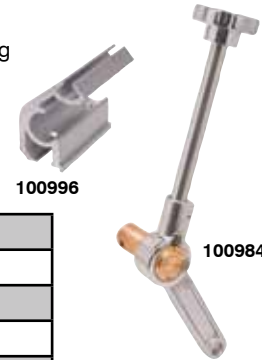

100984	Top Mount Control Assembly - straight
101005	Top Mount Control Assembly - angled
100983	Center Fill Extrusion (48" long)
100996	1-1/2" Top Mount Control (3.5" long)
101923	1-1/2" Arm Extension

Locking Push-Pull Control

- Recessed area in handle for 1" x 3" ID tags
- Polished chrome plated zinc handle and panel plate
- Quarter-turn locking in any position
- Hard coat anodized aluminum 3/4" rod
- Available with an aluminum linkage connector or brass ball swivel connector

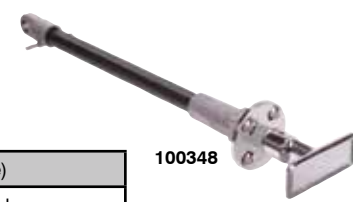

100348	Locking Push-Pull Control Assembly (9.5" stroke)
100348-S	Locking Push-Pull Control Assembly w/ball swivel
100348-SF	Locking Push-Pull Control Assembly w/ball swivel - female end

Swift Handle®

- Increased leverage for opening/closing valves
- No slot required in panel
- Increases panel strength
- Stainless steel cast lever
- T-handle or ball handle configurations

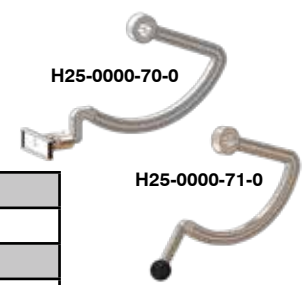

H25-0000-70-0-50	Swift Handle Assembly w/T-handle
121199	Casting, Swift Handle w/T-handle
H25-0000-71-0-50	Swift Handle Assembly w/Ball Handle
121200	Casting, Swift Handle w/ 3/8" Thread

Control Handle Assemblies

Hale Control Rod Assemblies are made with galvanized pipe with 1/2-20 thread inserts. Hale control rods are available in 1/2" increments starting at 6" up to 55". Longer sizes are available upon request. Contact Hale for specific part numbers.



Push-Pull Handle / Tag Adapter

Push-Pull Handle is for valve actuation control. The T-handle is specially designed to fit the hand with a recessed area for 1" x 3" ID tags. The T-handle is made of cast zinc and finished with polished chrome for panel enhancement. T-Handles are available for 3/4" and 1/2" rods.

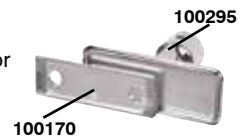

The Hale Adapter/Bezel adapts 1" x 3" recessed tag areas for push-pull T-handles and 1/4 turn ball valve bleeders to fit 3/4" x 2-1/2" tags. The adapter/bezel also can be used for stand-alone mounting of 3/4" x 2-1/2" tags. The tag adapter bezel is made of cast zinc and finished with polished chrome for tag enhancement. The adapter/bezel mounts with double sided tape or two (2) counter sunk screws. The adapter bushing is a stainless steel bushing to adapt the 3/4" rod T-handle to a 3/8" - 24 threaded rod with a 3/16" roll pin.

100294	T-Handle 3/4" Rod
100295	T-Handle 1/2" Rod
100170	Adapter/Bezel

Test Port Adapter

Ease of installation and simplicity of design make this test port assembly the best option for multiple tasks behind the panel. Each port has one front 1/4" NPT port, one back 1/4" NPT port, and two 1/4" DOT push-on fittings. The ports behind the panel are perfect for mounting pressure transducers for pressure governors. This assembly is made of brass with a chrome plated bezel identification tag.



Gauge Test Plug is nickel plated brass with a 1/4" NPT front port and 1/8" NPT back port.

121384	Test Port Assembly
102709	Gauge Test Plug (Nickel Plated Brass)



Automatic Master Drain

The Hale Automatic Master Drain has six individually sealed ports. The drain is normally open and is closed with air pressure. The master drain can be activated with an air switch for manual control or tied into an air operated pump shift for automatic control.



- All brass construction with stainless steel spring
- Six individually sealed ports
- 100 psi air pressure will hold 600 psi of water pressure
- Can be operated manually or automatically

103005	Master Drain
117491	Air Switch
546-3430-00-0	Repair Kit

Manual Master Drain

Manual Master Drain has twelve individually sealed ports that allow quick draining of multiple intake and discharge lines. The all brass and stainless steel construction allows for operation up to 600 psi.



121368	Manual Master Drain, 12 Port
104961	Manual Master Drain, 6 Port
107374	Repair Kit, 12 Port
546-2850-00-0	Repair Kit, 6 Port

3/4" Automatic Drain

The Automatic Drain normally opens and closes at 6 PSI. It can be mounted in the discharge line true low spot under the truck. Great for deck guns and front or rear jump lines.



- 3/4" Female NPT inlet
- Heavy duty neoprene seal
- All brass construction with stainless steel spring

34AD	3/4" Automatic Drain
105315	3/4" Automatic Drain 90°

3/4" Air Operated Drain

- Brass body
- One 3/4" female NPT inlet
- 1-1/4" bore air cylinder
- For use with air switch



110527	3/4" Air Operated Drain
104031	Air Toggle Switch

Ball Valve

- Nickel plated brass with chrome plated handle
- Reinforced Teflon® seals
- Meets NFPA specifications
- Multiple handle styles available

14BV	1/4" Ball Valve
38BV	3/8" Ball Valve
12BV	1/2" Ball Valve
34BV	3/4" Ball Valve
10BV	1" Ball Valve
14BVR	1/4" Ball Valve (Round Handle)
38BVR	3/8" Ball Valve (Round Handle)
12BVR	1/2" Ball Valve (Round Handle)
34BVR	3/4" Ball Valve (Round Handle)
10BVR	1" Ball Valve (Round Handle)
115639	3/4" Lift Handle Drain
34BV90	3/4" Ball Valve w/90° Elbow (Rectangle Handle)
34BVR90	3/4" Ball Valve w/90° Elbow (Round Handle)
120545	3/4" Ball Valve w/90° Elbow (Lift Handle)

See Page 73 for additional options and part numbers



Petcock Valve

Hale's Petcock Valve is an all brass assembly with a tag recess area in the chrome plated zinc handle. The petcock valve has 1/4" ports and is great for engine coolers, pump coolers and air valves.

105120	Petcock Valve
--------	---------------



Stainless Steel Swivels

Stainless steel swivels are available in several different configurations to best fit your application. The assemblies are centered around the polished 90° elbow, which is available in both 1.5" NH (short and long) and 2.5" NH threads. The 1.5" NH assemblies have 2.0" piping with a Victaulic connection. The 2.5" NH assemblies have 2.5" piping with a Victaulic connection. The assemblies can be ordered with or without the bumper flange.

- Specially designed elbow that reduces friction loss
- Polished all stainless steel construction
- Optional stainless steel bracket for mounting

102958	1.5" NH Short Swivel Elbow - 90° Piping - No Flange
104828	1.5" NH Short Swivel Elbow - 90° Piping - Bumper Flange
104289	1.5" NH Short Swivel Elbow - 90° Piping - Bumper Flange with 3/4" FNPT Drain
104831	2.5" NH Short Swivel Elbow - 90° Piping - Bumper Flange
104346	2.5" NH Short Swivel Elbow - 90° Piping - Bumper Flange with 3/4" FNPT Drain



Swivel without Flange



Swivel with Flange

High Pressure Flexible Piping



- High strength
- Abrasion resistant
- Ozone resistant
- Economical
- Flexible
- Choice of couplings
- Easy to install

Flexible Piping Dimensions				
INSIDE DIMENSIONS	OUTSIDE DIMENSIONS	WORKING PRESSURE	MIN. BEND RADIUS	WT./FT. (LBS)
1"	1.50"	250	4"	.25
1.5"	2.063"	300	6"	.92
2"	2.563"	300	8"	1.18
2.5"	3.188"	300	10"	1.710
3"	3.688"	300	12"	2.06
4"	4.844"	300	16"	3.30

Optional Hose Ends							
PIPING & COUPLING		SIZE (I.D.)					
		1"	1.5"	2.0"	2.5"	3"	4"
Stainless Male Pipe Coupling (MC)		10MCS	15MC	20MC	25MC	30MC	40MC
Stainless Victaulic Coupling (VC)		10VCS	15VC	20VC	25VC	30VC	40VC
Brass Female Swivel Coupling (FC)		N/A	15FC	20FC	25FC	30FC	N/A
Ferrule (FE)		10FES	15FE	20FE	25FE	30FE	40FE
Flexible Piping		10FP	15FP	20FP	25FP	30FP	40FP

Flexible Piping Ordering Information

Hale can quickly build your custom pipe assemblies for new construction or replacement hose needs.

- To order a custom built high pressure hose assembly:
- Determine the diameter of the hose required;
 - Determine the couplings required;
 - Determine the overall length of the engine hose assembly tip to tip.

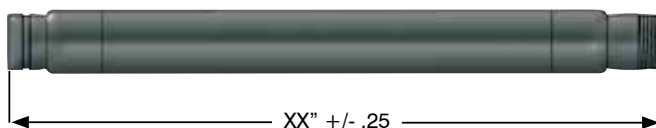

Example: 2.5" hose, female end by Victaulic end, 44" overall length (tolerance of +/- 1/4").

Grooved End Pipe Couplings

Groove end pipe couplings are recommended for piping applications involving moderate pressure and external stresses. It is suitable for many applications in industrial plants, OEM, HVAC and utility piping systems.

- Malleable iron ASTM A 47 or ductile iron ASTM A 536 construction with painted finish
- Connected with oval neck track bolts and heavy hex nuts per ANSI B18.10 and B18.22; Minimum tensile 110,000 psi ASTM A 183
- EPDM gasket

COUPLING	300 PSI RATED PART NUMBER	1000 PSI RATED PART NUMBER
1 1/2"	P10515W	088-00012-015
2"	P10520W	088-00012-020
2 1/2"	P10525W	088-00012-025
3"	P10530W	088-00012-030
4"	P10540W	088-00012-040
5"	P10550W	088-00012-050
6"	P10560W	088-00012-060



Groove End Pipe Coupling

Working pressures are based on hydrostatic tests with no external load using standard weight cut or roll grooved steel pipe.





Caps / Plugs / Adapters

Hale caps and fittings are specially designed for firefighting apparatus in styles that are priced for your needs.

- Patented self-venting lugs are designed to relieve trapped pressure and help reduce possible operator injuries
- Designed to meet NFPA 1963 and 1901 standards
- Bright polished finished
- 3" and smaller caps and plugs come complete with 12" chain
- 6" caps with custom logos available



	PART NUMBER	DESCRIPTION
ADAPTERS	107663	Adapter 1.5" MNH 1.5" MNPT
	107664	Adapter 2.5" MNH 1.5" MNH
	107683	Adapter 2.5" MNH 2.5" FNPT 2.63" LG
	107684	Adapter 2.5" MNH 2.5" FNPT 3.63" LG
	107668	Adapter 2.5" FNH 2.5" FNPT SWVL
	107670	Adapter 2.5" MNH 2.5" MNPT
	107671	Adapter 2.5" MNH 2.5" MNPT SWVL
	107673	Adapter 2.5" MNH 2.5" MNH 30 DEG
	107678	Adapter 3.0" MNH 3.0" MNH 30" DEG
	107679	Adapter 3.0" MNH 3.0" FNPT
CAPS	008-0100-00-0	Cap 1.5" NH with Lug Vent
	108007	Cap 2.5" NH with lug vent
	108008	Cap 3.0" NH with lug vent
	109196	Cap 4.0" NH (flat cap) vent
	108162	Cap 4.5" NH (flat cap) vent
	108344	Cap 5.0" NH (flat cap) vent
	109401	Cap 6.0" NH recessed assembled with vent
	108345	Cap 6.0" NH (flat cap) vent
PLUGS	107666	Plug 2.5" NH with chain
	107675	Plug 3.0" NH with chain

Air Operated Valve Cylinder & Bracket

Our Air Cylinders are fabricated using aluminum head and tube body with a chrome plated piston. These cylinders include the front trunnion mount with a clevis for mounting to the bracket and valve.

The Brackets are precision punched and formed using hot rolled steel with two welded 7/8" mounting pads for mounting to the valve and a Black powder paint finish.

BRACKET PART NUMBER	90° BRACKET PART NUMBER	AIR CYLINDER PART NUMBER (BORE X STROKE)	HALE 800 SERIES SVS VALVES, AKRON 7600 & 7800 SERIES VALVES	AIR TOGGLE SWITCH ASSEMBLY
10BRK	100386	320600 (1.20 X 6)	1"	117491
15BRK	15BRK90	400550 (1.5 X 5.5)	1 1/2"	117491
20BRK	20BRK90	400550 (1.5 X 5.5)	2"	117491
25BRK	25BRK90	400550 (1.5 X 5.5)	2 1/2"	117491
30BRK	30BRK90	630550 (2.5 X 5.5)	3"	117491

Air Operated Valve Cylinder



Air Operated Valve Cylinder Bracket

Air Toggle Switch Assembly



Air Brake Tubing

Hale also offers an assortment of air brake tubing in sizes from 1/4" to 3/4" and colors in Red, Black, and Blue. (Only available in full rolls.)

PART NUMBER	SIZE/COLOR	FULL ROLL
604-00012-001	1/4" Black	1000'
104939	1/4" Red	1000'
104942	1/4" Blue	1000'
604-00013-001	3/8" Black	1000'
104948	1/2" Black	500'
104953	5/8" Black	250'
604-00016-001	3/4" Black	250'





Push-on Fittings

DOT Push-on Fittings

Hale's DOT Push-On Fittings are available in a variety of sizes from 1/4" to 3/4" and a variety of configurations including 45° and 90° elbow, swivel and nonswivel, straight, tee and bulkhead.



P/N	DOT HOSE SIZE					NON-SWIVEL NPT THREAD SIZE								FEATURES							
	1/4" POH	3/8" POH	1/2" POH	5/8" POH	3/4" POH	1/8" Female NPT	1/4" Female NPT	3/8" Female NPT	1/8" Male NPT	1/4" Male NPT	3/8" Male NPT	1/2" Male NPT	3/4" Male NPT	Straight	90° Elbow (Swivel)	90° Elbow (Non-Swivel)	45° Elbow (Swivel)	45° Elbow (Non-Swivel)	Tee (Swivel)	Bulkhead	Union
102718	•						•								•						
104587	•													•							•
104588		•												•							•
104589	•								•					•							
104590		•							•					•							
104591	•									•				•							
104592		•								•				•							
104593		•									•			•							
104594		•										•		•							
104595					•							•		•							
104596					•								•	•							
104597	•								•								•				
104598	•								•					•							
104599		•							•					•							
104600	•									•						•					
104601		•								•						•					
104602		•									•					•					
104603		•										•				•					
104604					•							•				•					
104605					•								•				•				
104606	•									•									•		
104609	•							•						•							
104795			•							•				•							
104796			•								•			•							
104797			•								•			•							
104798	•									•							•				
104799	•						•							•						•	



DOT Push-on Fittings (Cont.)

P/N	DOT HOSE SIZE					NPT THREAD SIZE							FEATURES								
	1/4" POH	3/8" POH	1/2" POH	5/8" POH	3/4" POH	1/8" Female NPT	1/4" Female NPT	3/8" Female NPT	1/8" Male NPT	1/4" Male NPT	3/8" Male NPT	1/2" Male NPT	3/4" Male NPT	Straight	90° Elbow (Swivel)	90° Elbow (Non-Swivel)	45° Elbow (Swivel)	45° Elbow (Non-Swivel)	Tee (Swivel)	Bulkhead	Union
104800			•							•				•							
104801	•													•							•
104803			•								•			•							
104804	•										•			•							
104805		•								•							•				
104806	•										•			•							
104807				•								•		•							
104808				•							•			•							
104809				•								•			•						
104810				•							•			•							
104811		•							•							•					
104812			•							•						•					
104813				•								•				•					
104816	•						•							•							
104819		•								•									•		
104821	•								•										•		
104822			•											•							•
104823				•										•							•
104824		•					•												•		
104914	•								•							•					
105176	•					•								•	•						
105178		•											•		•						
105179		•											•	•							
105181				•									•		•						
105589					•								•			•					
105590					•								•		•						
106262	•								•										•		

Flange - Valve x Weld										
VALVE x WELD										
	VALVE SIZE	1"	1.5"	2" x 1.5"	2"	2.5"	3"	3"	4"	4"
	PART #	104301	112381	120989	122427	122428	122429	114408	110156	110157
	HEIGHT	2.25"	2.25"	2.25"	2.25"	2.25"	2.25"	3.00"	2.82"	2.82"
	OUTLET DIA.	1"	1.5"	1.5"	2"	2.5"	3"	4"	4"	4"
	FEMALE PORT	1/4" FNPT	1/4" FNPT	1/4" FNPT	1/4" FNPT	1/4" FNPT	1/4" FNPT	3/4" FNPT	3/4" FNPT	Flowminder Port

Flange - Valve x Groove						
VALVE x GROOVE						
	VALVE SIZE	1.5"	2" x 1.5"	2"	2.5"	3"
	PART #	112391	120991	112392	112393	112394
	HEIGHT	2.25"	2.25"	2.8"	2.9"	2.9"
	OUTLET DIA.	1.5"	1.5"	2"	2.5"	3"
	FEMALE PORT	3/4" FNPT	3/4" FNPT	3/4" FNPT	3/4" FNPT	3/4" FNPT

VALVE x GROOVE w/ FLOWMINDER PORT				
	VALVE SIZE	2"	2.5"	3"
	PART #	112404	112405	112406
	HEIGHT	2.8"	2.9"	2.9"
	OUTLET DIA.	2"	2.5"	3"
	FEMALE PORT	Flowminder Port	Flowminder Port	Flowminder Port

VALVE x GROOVE - DROOP		
	VALVE SIZE	3"
	PART #	114627
	HEIGHT	-
	OUTLET DIA.	3"
	FEMALE PORT	-

VALVE x GROOVE - ELBOW 90°				
	VALVE SIZE	2"	2.5"	3"
	PART #	115223	115221	115219
	HEIGHT	3"	3"	3.69"
	OUTLET DIA.	2"	2.5"	3"
	FEMALE PORT	3/4" FNPT	3/4" FNPT	3/4" FNPT

VALVE x GROOVE - ELBOW 45°				
	VALVE SIZE	2"	2.5"	3"
	PART #	115222	115220	115218
	HEIGHT	-	-	-
	OUTLET DIA.	2"	2.5"	3"
	FEMALE PORT	3/4" FNPT	3/4" FNPT	3/4" FNPT

Flange - Valve x Hose							
VALVE x HOSE - MNH THREAD							
	VALVE SIZE	1.5"	1.5"	2" x 1.5"	2.5"	3.0"	4"
	PART #	044-1750-06-0	115560	120988	044-1770-13-0	044-1781-09-0	115917
	HEIGHT	1.53"	2"	1.53"	3.75"	6"	8.25"
	OUTLET DIA.	1.5"	1.5"	1.5"	2.5"	3"	4"
	FEMALE PORT	3/4" FNPT	3/4" FNPT	3/4" FNPT	3/4" FNPT	3/4" FNPT	3/4" FNPT

VALVE x HOSE - FNH SWIVEL			
	VALVE SIZE	2.5"	3"
	PART #	C25-2600-00-0-50	C30-2600-00-0-50
	HEIGHT	7"	7"
	OUTLET DIA.	2.5"	3"
	FEMALE PORT	3/4" FNPT	3/4" FNPT

VALVE x HOSE - ELBOW 45° - MNH THREAD			
	VALVE SIZE	2.5"	3"
	PART #	044-1771-11-0	044-1781-12-0
	HEIGHT	-	-
	OUTLET DIA.	2.5"	3"
	FEMALE PORT	3/4" FNPT	3/4" FNPT

VALVE x HOSE - MNH THREAD		
	VALVE SIZE	3"
	PART #	114471
	HEIGHT	5.5"
	OUTLET DIA.	4"
	FEMALE PORT	3/4" FNPT

VALVE x HOSE - BARB		
	VALVE SIZE	3"
	PART #	044-1781-07-0
	HEIGHT	3"
	OUTLET DIA.	3.5" ID
	FEMALE PORT	1/4" FNPT

Flange - Valve x FNPT						
VALVE x FNPT THREAD						
	VALVE SIZE	1.5"	2" x 1.5"	2"	2.5"	3"
	PART #	044-1751-02-0	120986	044-1761-02-0	044-1771-02-0	044-1781-02-0
	HEIGHT	2.53"	2.53"	2.21"	2.68"	2.71"
	OUTLET DIA.	1.5"	1.5"	2"	2.5"	3"
	FEMALE PORT	1/4" FNPT	1/4" FNPT	1/4" FNPT	1/4" FNPT	1/4" FNPT
VALVE x FNPT THREAD w/DRAIN						
	VALVE SIZE	2"		2.5"	3"	
	PART #	044-1771-03-0		044-1761-03-0	044-1781-03-0	
	HEIGHT	2.21"		2.68"	2.71"	
	OUTLET DIA.	2"		2.5"	3"	
	FEMALE PORT	3/4" FNPT		3/4" FNPT	3/4" FNPT	
Flange - Valve x 115						
VALVE x 115						
	VALVE SIZE	3"	3"	3"	3"	
	PART #	113637	111069	115083	117020	
	PANEL	70"	72"	74"	76"	
	HEIGHT	5.7"	6.7"	7.7"	8.7"	
	FEMALE PORT	1/4" FNPT	1/4" FNPT	1/4" FNPT	1/4" FNPT	
VALVE x 115						
	VALVE SIZE	3"	3"	3"	3"	
	PART #	113638	111070	115087	117021	
	PANEL	70"	72"	74"	76"	
	HEIGHT	5.2"	5.2"	7.2"	8.2"	
	FEMALE PORT	1/4" FNPT	1/4" FNPT	1/4" FNPT	1/4" FNPT	
VALVE x 115 - 90° ELBOW						
	VALVE SIZE	2.5"	2.5"	2.5"	2.5"	
	PART #	113641	111071	115082	117022	
	PANEL	70"	72"	74"	76"	
	HEIGHT	2.7"	3.7"	4.7"	5.7"	
	FEMALE PORT	1/4" FNPT	1/4" FNPT	1/4" FNPT	1/4" FNPT	
VALVE x 115						
	VALVE SIZE	1.5"	2"	2.5"		
	PART #	113270	113271	112408		
	HEIGHT	2.5"	3.75"	3.75"		
	OUTLET DIA.	1.5"	2"	2.5"		
	FEMALE PORT	1/4" FNPT	1/4" FNPT	1/4" FNPT		
VALVE x 115 - 90° OFFSET						
	VALVE SIZE	2.5"	2.5"	2.5"		
	PART #	114490	113639	117133		
	PANEL	72"	74"	76"		
	FEMALE PORT	1/4" FNPT	1/4" FNPT	1/4" FNPT		
	VALVE x 115					
	VALVE SIZE	2.5"				
	PART #	116095				
	HEIGHT	4"				
	OFFSET	1.5"				





Plumbing Products

HALE PRODUCTS INC | PH. 800.533.3569 | haleproducts.com







Flange - 115 x Weld			
115 x WELD			
	PART #	104302	104209
	HEIGHT	2.25"	2.25"
	PIPE DIA.	2"	2.5"
			104210
			2.25"
			3"



115 x WELD - COPED			
	PART #	105289	109972
	COPED SIZE	4" / 5"	6"
	PIPE DIA.	3"	3"

115 x WELD - 27° ELBOW		
	PART #	115733
	HEIGHT	1.5"
	PIPE DIA.	3"
	FEMALE PORT	1/4" FNPT

Flange - 115 x Groove			
115 x GROOVE			
	PART #	105810	105326
	HEIGHT	2.25"	2.25"
	PIPE DIA.	2"	2.5"
			105811
			2.25"
			3"

Flange - 115 x NPT			
115 x NPT			
	PART #	111892	114131
	HEIGHT	1.25"	1.38"
	PIPE DIA.	2.5"	3"

Flange - 115 x 115			
		115 x 115 FLANGE	
PART #	110574		
HEIGHT	.50"		
		115 x 115 SPACER	
PART #	113640	114891	
THICK	1"	.44"	
		115 x 115 90° ELBOW	
PART #	113081		
HEIGHT	2.94"		
PIPE DIA.	2.5"		
FEMALE PORT	1/4" FNPT		
		115 x 115 PLATE	
PART #	113386		
HEIGHT	.08"		
		115 x 115 SPACER	
PART #	115795		
HEIGHT	2.5"		
		115 x 115 OFFSET	
PART #	114491		
HEIGHT	4"		
OFFSET	1.5"		

TEES			
		112692	
PIPE DIA.	5" (GROOVE)		
LENGTH	10"		
HEIGHT	4.2" (from C/L to Groove)		
FEMALE PORT	(2) 3/4" FNPT 1/4" FNPT		
SOCKET WELD	5"		
		112867	
PIPE DIA.	6" (GROOVE)		
LENGTH	10"		
HEIGHT	5.25" (from C/L to Groove)		
FEMALE PORT	(3) 3/4" FNPT 45° apart		
SOCKET WELD	5"		

178-0470-00-0 8-BOLT x 6"			
	WIDTH	12.5"	
	DEPTH	12.5"	
	HEIGHT	2.5" (from C/L to Groove)	
	FEMALE PORT	(2) 3/4" FNPT	
	SOCKET WELD	6"	

CHECK VALVE			
		116485	
		VALVE	3"
		WIDTH	9.5"
		HEIGHT	5.81" (from C/L to Groove)
		SOCKET WELD	6"
178-00199-000			
		PIPE DIA.	5"
		WIDTH	11.67"
		HEIGHT	5.38" (from C/L to Groove)
178-00031-000			
		PIPE DIA.	6"
		WIDTH	11.67"
		HEIGHT	5.38" (from C/L to Groove)
538-1840-00-0 DUAL CHECK VALVE			
		PIPE DIA.	3" (GROOVE)
		LENGTH	15"
		PORT	FLOWMINDER
		FEMALE PORT	1" FNPT
538-1850-00-0 SINGLE CHECK VALVE			
		PIPE DIA.	3" (GROOVE)
		LENGTH	9.5"
		PORT	FLOWMINDER
		FEMALE PORT	1" FNPT
112074 SINGLE CHECK VALVE			
		PIPE DIA.	2" (GROOVE)
		LENGTH	8.5"
		PORT	FLOWMINDER
		FEMALE PORT	1" FNPT
113216			
		VALVE	3"
		HEIGHT	4.53"
		PORT	FLOWMINDER
		FEMALE PORT	(2) 1/4" FNPT

RELIEF VALVE				
PRESSURE RELIEF VALVES				
	PART #	538-1920-10-0	538-1920-20-0	538-1920-00-0
	THREAD	NPT	NH	VIC
	FLANGE	115	115	115

MIXER				
MIXER				
	PART #	112334	112335	112336
	DIAMETER	2"	2.5"	3"

O-RING		
	PART #	142-0390-00-0
	SIZE	115 FLANGE

GASKETS		
	PART #	046-0050-00-0
	SIZE	115 FLANGE
	PART #	046-0060-00-0
	SIZE	8-BOLT FLANGE
	PART #	046-1760-00-0
	SIZE	8-BOLT FLANGE (Use with 115-00038, 122870, 110155)
	PART #	046-0040-00-0
	SIZE	12-BOLT FLANGE



Plumbing Products

HALE PRODUCTS INC | PH. 800.533.3569 | haleproducts.com

Flange - 8-BOLT (2433)

8-BOLT (2433) x VALVE 1.5" OFFSET			8-BOLT (2433) x VALVE 1.85" OFFSET		
	VALVE SIZE	3"		VALVE SIZE	3"
	PART #	113272		PART #	115393
	OFFSET	1.5"		OFFSET	1.85" @ 4°
	HEIGHT	3"		HEIGHT	3.38"

8-BOLT (2433) x VALVE 4° OFFSET			8-BOLT (2433) x VALVE 3" OFFSET		
	VALVE SIZE	3"		VALVE SIZE	3"
	PART #	113273		PART #	113274
	OFFSET	4°		OFFSET	3" @ 4°
	HEIGHT	3.25"		HEIGHT	7.10"

8-BOLT (2433) x VALVE			
	VALVE SIZE	2.5"	3"
	PART #	044-00025	112407
	HEIGHT	2.63"	2.50"

8-BOLT (2433) x 2.5" VALVE EXTENSION					
	VALVE SIZE	2.5"			
	PART #	159-2230-00-0	159-2230-02-0	159-2230-04-0	159-2230-06-0
	LENGTH	5.7"	6.7"	7.7"	8.7"

8-BOLT (2433) x 3" VALVE EXTENSION					
	VALVE SIZE	3"			
	PART #	159-2230-01-0	159-2230-03-0	159-2230-05-0	159-2230-07-0
	LENGTH	5.7"	6.7"	7.7"	8.7"

Flange - 8-BOLT x Weld

8-BOLT x WELD			
	PIPE DIA.	3"	4"
	PART #	122870	110155
	HEIGHT	2.25"	2.25"

Flange - 8-BOLT x Groove

8-BOLT x GROOVE		
	PIPE DIA.	3"
	PART #	115-00038
	HEIGHT	2.25"

Flange - 8-BOLT

8-BOLT FLANGE		
	PART #	109433
	THICKNESS	0.50"

Flange - 12-BOLT x Groove

12-BOLT x GROOVE		
	PIPE DIA.	6"
	PART #	110986
	HEIGHT	3.5"

AP/MBP DISCHARGE		
122438	122439	122440

121683	121684

DSD DISCHARGE	
119075 - TEE	119076 - BRANCH



MANIFOLDED DISCHARGE			
		115 x GROOVE - 90° ELBOW	115 x WELD - 90° ELBOW
	PART #	113342	113343
	HEIGHT	4.9"	4.9"
	FLANGE	115	115
110119			
	PIPE DIA.	3"	
	LENGTH	12.25"	
	PIPE OPENING	2"	
	CONNECTION	WELD / GROOVE	
113275			
	PIPE DIA.	3"	
	ADAPTER	2 x 3/8"-16 UNC	
	CONNECTION	115 FLANGE @ 4° / GROOVE	



Plumbing Products

HALE PRODUCTS INC | PH. 800.533.3569 | haleproducts.com



MANIFOLDED DISCHARGE Cont.



113344		
	PIPE DIA.	3"
	ADAPTER	2 x 3/8"-16 UNC
	CONNECTION	115 FLANGE @ 4° / GROOVE
114396		
	PIPE DIA.	3"
	LENGTH	6"
	PIPE OPENING	2.5"
	CONNECTION	GROOVE / BELL PIPE
114397		
	PIPE DIA.	3"
	LENGTH	6"
	PIPE OPENING	2"
	CONNECTION	GROOVE / GROOVE

PORTABLE DISCHARGE

111647	111648	111650
		

PORTABLE SUCTION

119075 - TEE	119076 - BRANCH
	

















PORTABLE ADAPTER				
111715		115553		
	HEIGHT	1.68"	HEIGHT	1"
	CONNECTION	2.5" GROOVE / 2" MNPT	CONNECTION	3/4" PIPE x 3/4" MNH
115453		112075 CHECK VALVE		
	VALVE	1.5"	VALVE	115
	HEIGHT	7"	HEIGHT	3.7"
	PIPE OPENING	2"	PIPE OPENING	1.5 MNPT
	PIPE DIA.	GROOVE / GROOVE	FEMALE PORT	1/4" FNPT
118903				
	LENGTH	4.25"		
	PORTS	3 - 2" CLOSED		
	PIPE OPENING	3"		
	CONNECTION	GROOVE		

BALL VALVES							
BV BALL VALVES							
	VALVE SIZE	1/4"	3/8"	1/2"	3/4"	1"	
	PART #	14BV	38BV	12BV	34BV	10BV	
	PORT	FNPT	FNPT	FNPT	FNPT	FNPT	
	HANDLE	RECTANGLE	RECTANGLE	RECTANGLE	RECTANGLE	RECTANGLE	
BVR BALL VALVES							
	VALVE SIZE	1/4"	3/8"	1/2"	3/4"	1"	
	PART #	14BVR	38BVR	12BVR	34BVR	10BVR	
	FITTING PORT	FNPT	FNPT	FNPT	FNPT	FNPT	
	HANDLE	ROUND	ROUND	ROUND	ROUND	ROUND	
90° BALL VALVE (RECTANGLE HANDLE)		90° BALL VALVE (ROUND HANDLE)					
	VALVE SIZE	3/4" 90°			VALVE SIZE		3/4" 90°
	PART #	34BV90			PART #		34BVR90
	FITTING PORT	2 - 3/4" FNPT 1/8" FNPT			FITTING PORT		2 - 3/4" FNPT 1/8" FNPT
	HANDLE	RECTANGLE			HANDLE		ROUND
3/4" DISCHARGE VALVE (RECTANGLE)		3/4" SUCTION VALVE (RECTANGLE)					
	VALVE SIZE	3/4" 90°			VALVE SIZE		3/4" 90°
	PART #	115637			PART #		110829
	FITTING PORT	3/4" POH 1/4" POH 1/2" ID HOSE BARB			FITTING PORT		3/4" POH 1/2" ID HOSE BARB
	HANDLE	RECTANGLE			HANDLE		RECTANGLE
3/4" DISCHARGE VALVE (LIFT)		3/4" SUCTION VALVE (LIFT)					
	VALVE SIZE	3/4"			VALVE SIZE		3/4"
	PART #	115637			PART #		115638
	FITTING PORT	3/4" POH 1/4" POH 1/2" ID HOSE BARB			FITTING PORT		3/4" POH 1/2" ID HOSE BARB
	HANDLE	LIFT			HANDLE		LIFT
3/4" VALVE (LIFT)							
	VALVE SIZE	3/4"					
	PART #	115639					
	FITTING PORT	3/4" FNPT					
	HANDLE	LIFT					



Plumbing Products

HALE PRODUCTS INC | PH. 800.533.3569 | haleproducts.com

LEVERS							
	PART #	115164		116303			
	HOLE DIA.	3.25" / 4"		4" / 6.13"			
	PART #	116304			PART #	101923	
	THREAD	7/16" - 14 UNC			EXTENSION	1.5"	
	PART #	114659			PART #	114551	
	THREAD	7/16" - 14 UNC			EXTENSION	3" @ 45°	
	OFFSET	.56"					
HANDLES							
RECTANGLE							
	PART #	100899		100074			
	VALVES	14BV 38BV 12BV		34BV 34BV90 10BV			
ROUND							
	PART #	102485		102486			
	VALVES	14BV 38BV 12BV		34BV 34BV90 10BV			
LIFT							
	PART #	114997					
	VALVES	34BV					
BRACKETS							
SUCTION MOUNT							
	PART #	112737		112736			
	MOUNT	UPPER		LOWER			
	PIPE DIA.	6"		6"			
CROSSLAY MOUNT							
	PART #	113799	113798	111428	111429		
	MOUNT	UPPER	LOWER	UPPER	LOWER		
	PIPE DIA.	2"	2"	2.5"	2.5"		
BODY MOUNT			DECK GUN CLAMP				
	PART #	112738			PART #	110679	
					PIPE DIA.	3"	
AIR CYLINDER MOUNT							
	PART #	10BRK	15BRK	20BRK	25BRK	30BRK	
	VALVE	1"	1.5"	2"	2.5"	3"	
AIR CYLINDER MOUNT 90°							
	PART #	10BRK90	15BRK90	20BRK90	25BRK90	30BRK90	
	VALVE	1"	1.5"	2"	2.5"	3"	
FOAM SYSTEM BRACKET			PANEL LATCH				
	PART #	116641			PART #	114722	

ELBOWS

	PART #	110671		PART #	110672
	PIPE DIA.	2"		PIPE DIA.	2"
	ANGLE	90°		ANGLE	180°
	FEMALE PORT	3/4" FNPT			
	PART #	112062		PART #	113080
	PIPE DIA.	2.5"		PIPE DIA.	2"
	ANGLE	90°	ANGLE	90°	
	CONNECTION	2.5" GROOVE x 2.5" MNPT		PART #	114000
LENGTH	3.8" x 3.45"	PIPE DIA.		2"	
			ANGLE	90°	
	PART #	120617			
	PIPE DIA.	2.5"			
	ANGLE	90°			
	LENGTH	3.75" x 9.75"			
	PART #	114537	114536	114715	
	PIPE DIA.	2"	2.5"	5"	
	ANGLE	90°	90°	90°	
	CONNECTION	GROOVE / GROOVE	GROOVE / GROOVE	GROOVE / GROOVE	

ADAPTERS

	PART #	113064		PART #	114066
	HEIGHT	4.1"		HEIGHT	3.25"
	PIPE DIA.	2" ID		PIPE DIA.	3"
	THREAD	1.25" FNPT		THREAD	3" MNPT
	COPE	4"			
	PART #	115744			
	HEIGHT	4.03"			
	PIPE DIA.	3"			
	THREAD	3" Groove / 4" Cove			















TEES

114406	110116
115106	110111



Plumbing Products

HALE PRODUCTS INC | PH. 800.533.3569 | haleproducts.com

CONTROL ROD ENDS					
	PART #	118424	118425	118426	
	OFFSET	1.5"	3"	4"	
	LENGTH	6.75"	6.75"	6.74"	
	THREAD	FEMALE 1/2-20 UNF MALE 1/2-20 UNF	FEMALE 1/2-20 UNF MALE 1/2-20 UNF	FEMALE 1/2-20 UNF MALE 1/2-20 UNF	
	PART #	100916			
	THREAD	FEMALE 1/2-20 UNF MALE 1/2-20 UNF			
	PART #	121024			
	LENGTH	3.5"			
	THREAD	FEMALE 1/2-20 UNF MALE 1/2-20 UNF			
YOKES					
STRAIGHT		OFFSET			
	PART #	103402		PART #	105235
	LENGTH	3"		LENGTH	2.25"
	THREAD	FEMALE 1/2-20 UNF		THREAD	FEMALE 1/2-20 UNF
	OFFSET	-		OFFSET	.83"
ANGLED LONG		ANGLED SHORT			
	PART #	103448		PART #	106672
	LENGTH	3.25"		LENGTH	2.75"
	THREAD	FEMALE 1/2-20 UNF		THREAD	FEMALE 1/2-20 UNF
	HEIGHT	1.75"		OFFSET	.88"
PIN					
	PART #	103403			
	LENGTH	1.72"			
	OUTSIDE DIA.	.49"			
	COTTER PIN	1/8"			
BELL CRANKS					
	PART #	114214 LEFT	114215 RIGHT		
	OFFSET	1.25"	1.25"		
	PART #	114499			
	LENGTH	3.25" / 4"			
	PART #	116474			
	LENGTH	2 X 4.5"			
BOLT					
	PART #	113305			
	THREAD	3/8-16 UNC			
AUX SUCTION BRACKET					
	PART #	119707			
	THREAD	FEMALE 3/8-16 UNC			
RIGHT REAR DISCHARGE BRACKET					
	PART #	116475			
	THREAD	FEMALE 3/8-16 UNC			

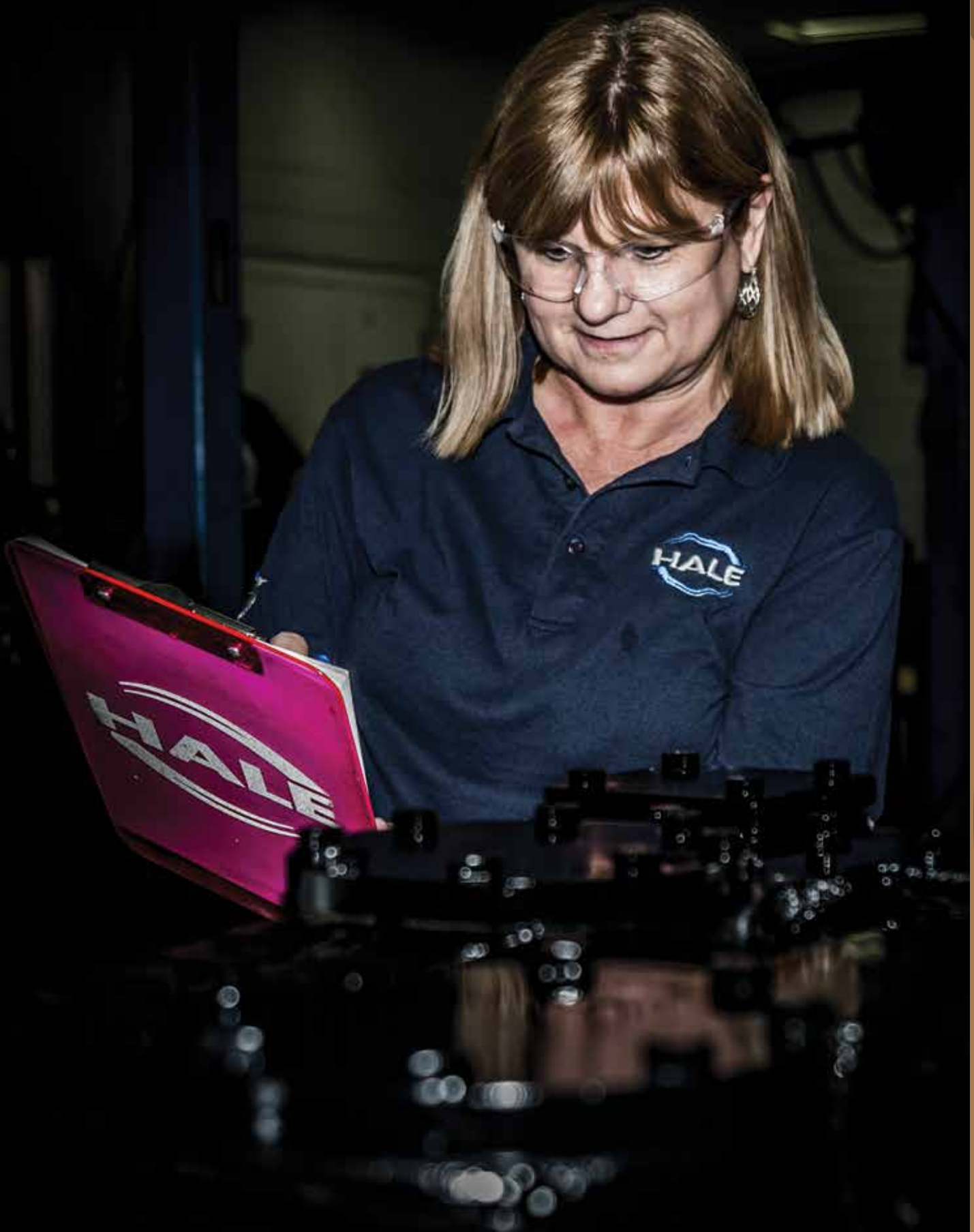



Available Pump Gearbox & Seal Compatibility (Gearbox and Seals)

PUMP	G Box in S (Short)	G Box in L (Long)	G Box in X (Extra Long)	G Box in R (Ahead of Pump)	MG Gearbox	K Box in L (Long)	K Box in X (Extra Long)	Packing	Mechanical Seal
Qmax	✓	✓	✓	✓		✓	✓	✓	✓
Qmax-XS	✓	✓	✓	✓		✓	✓	✓	✓
Qtwo	✓	✓	✓	✓		✓	✓	✓	✓
Qflo		✓	✓						✓
DSD	✓	✓	✓	✓					✓
8FGR/8FKR			✓	✓			✓		✓
8FGF/8FKF		✓	✓				✓		✓
MG/APMG					✓				✓
LGA/XGA		✓	✓						
RGA				✓					
MGA					✓				
LKA/XKA						✓	✓		

Gearbox Designation

K - Designed for high usage requirements, large cities and industries such as refineries and petrochemical with high horsepower requirements and high road mileage. 18,500 lb. ft. of drive torque, the K gearbox is ideal for high powered engines and is rated for up to 550 HP engines.

S - Short version of the "G".

L - Long version of the "G" manifolded split drive full capacity gearbox (most popular gearbox).

X - Extra long version of the "G" manifolded split drive full capacity gearbox.

R - Reverse long version of the "G" manifolded split drive full capacity gearbox.

MG - manifolded split drive gearbox.

NFPA Rated Flows

Pump	Rated Flow (gpm) @ 150 psi	Rated Flow (lpm) @ 10 Bar	Stage	PTO	Split Driveline	Engine Driven
Manifolded Pumps						
Qmax-XS / Qmax	1000 - 2250 gpm	4000 - 8000 lpm	Single	✓	✓	
Qtwo	1000 - 2000 gpm	4000 - 8000 lpm	Two	✓	✓	
Qflo Plus	750 - 1250 gpm	3000 - 5000 lpm	Single	✓	✓	
Non-Manifolded Pumps						
2CBP*	100 gpm @ 300 psi	379 lpm @ 21 bar	Two	✓		
CBP	250 gpm	750 - 1000 lpm	Single	✓		✓
AP / APMG	250 - 500 gpm	1000 - 2000 lpm	Single	✓	✓	✓
KP1 / KP2	250 - 500 gpm	1000 - 2000 lpm	Single / Multi	✓		
MG	500 - 1000 gpm	1000 - 3000 lpm	Single	✓	✓	
TBP	500 - 750 gpm	2000 lpm	Two	✓		
MBP	500 - 1000 gpm	3000 lpm	Single	✓		✓
PRIMA	750 - 1500 gpm	2000 - 6000 lpm	Single / Multi	✓		
DSD / RSD	750 - 1500 gpm	3000 - 5000 lpm	Single	✓	✓	✓
8FG	1500 - 3000 gpm	6000 - 11000 lpm	Single	✓	✓	✓
Industrial High Flow						
RME	1500 - 3000 gpm	6000 - 11,000 lpm	Single	✓		

* 2CBP is not NFPA rated

NFPA 1901 Discharge Ratings

NFPA requires outlet connections sufficient to move the pump's rated capacity through delivery hose (and the aerial device, if applicable). The rating system is based on ideal flow through a given hose size. The rating system uses the first permanent fire hose connection on each outlet to be counted as the size of the outlet (Rating is NOT based on piping or valve size inside the truck). There must be at least two (2) 2-1/2" outlets and any combination of equal or larger outlets to equal or exceed the pump rating. Discharge outlet connection ratings are:

Discharge Size - in. (mm)	Flow Rate - gpm (lpm)
2.5" (65)	250 (1000)
3" (75)	375 (1400)
4" (100)	625 (2400)
5" (125)	1000 (4000)
6" (150)	1500 (6000)

A permanently connected aerial waterway is rated at 1000 GPM, if provided. 1" to 2" outlet connections are not counted towards pump rating. Deck guns on pumpers do not count towards pump rating other than the base of gun connections (2-1/2" or 3" connection) for stream straightener.



TECHNICAL DATA

Pump Rated Flow Ranges

Pump	2CBP*	CBP	KP1 / KP2	AP	APMG	MG	TBP	MBP	P1	P2	Qflo Plus	DSD	RSD	Qtwo	Qmax	Qmax-XS	8FG / 8FK	80FC	80FCG	RME
100 gpm 379 lpm	■																			
198 gpm 750 lpm			■																	
250 gpm 946 lpm		■	■	■																
264 gpm 1000 lpm			■	■	■															
396 gpm 1500 lpm			■	■	■	■														
500 gpm 1893 lpm			■	■	■	■	■													
528 gpm 2000 lpm				■	■	■	■	■	■	■										
660 gpm 2500 lpm					■	■	■	■	■	■	■									
750 gpm 2839 lpm						■	■	■	■	■	■	■	■							
793 gpm 3000 lpm						■	■	■	■	■	■	■	■							
1000 gpm 3785 lpm						■	■	■	■	■	■	■	■	■	■	■				
1057 gpm 4000 lpm									■	■	■	■	■	■	■	■	■			
1189 gpm 4500 lpm									■	■	■	■	■	■	■	■	■			
1250 gpm 4732 lpm									■	■	■	■	■	■	■	■	■			
1321 gpm 5000 lpm									■	■	■	■	■	■	■	■	■			
1500 gpm 5678 lpm									■	■	■	■	■	■	■	■	■	■	■	■
1585 gpm 6000 lpm									■	■	■	■	■	■	■	■	■	■	■	■
1717 gpm 6500 lpm										■	■	■	■	■	■	■	■	■	■	■
1750 gpm 6624 lpm											■	■	■	■	■	■	■	■	■	■
2000 gpm 7571 lpm												■	■	■	■	■	■	■	■	■
2113 gpm 8000 lpm													■	■	■	■	■	■	■	■
2250 gpm 8517 lpm														■	■	■	■	■	■	■
2500 gpm 9464 lpm															■	■	■	■	■	■
2642 gpm 10,000 lpm																■	■	■	■	■
2750 gpm 10,410 lpm																	■	■	■	■
3000 gpm 11,356 lpm																		■	■	■

* 2CBP is not NFPA rated



Available Pump Ports and Sizes

PORT ID	QMAX Standard	QMAX Optional	QMAX-XS Standard	QMAX-XS Optional	QTWO Standard	QTWO Optional	QFLO PLUS Standard	QFLO PLUS Optional
A	4"		4"		4"			4"
B	3"		3"		3"		3"	
C	4"		4"		4"		3"	
D	3"		3"		3"			3"
E	3"		3"		3"			3"
F	3"		3"		3"			3"
G	3"		3"		3"			3"
H	4"		4"		4"		4"	
I			3"					
J			3"					
K	3"		4"		3"		3"	
L	3"		4"		3"		3"	
M	3"		4"		3"		3"	
N	3"		4"		3"		3"	
O	3"		4"		3"		3"	
P	3"	4"	4"		3"	4"	3"	4"
Q	3"		4"		3"		3"	
R	3"		4"		3"		3"	
S	TTP		TTP		TTP		TTP	
T		TTP/6"		TTP/6"		TTP/6"		
U	3"		3"		3"		3"	
V	3"		3"		3"		3"	
W	3"		3"		3"		3"	
X	3"		3"		3"		3"	
Z			4"					
BOTTOM		6"		6"		6"		6"

Single Port Flow (Discharge)*				
	Qflow Plus	Qmax	Qmax-XS	Qtwo
RH Front Side 4" (P)	-	2600 (9842)	2600 (9842)	2600 (9842)
RH Side 3" (P or R)	1500 (5678)	1500 (5678)	1500 (5678)	1500 (5678)
LH Front Side 4" (O)	-	-	2600 (9842)	-
LH Side 3" (O or Q)	1500 (5678)	1500 (5678)	1500 (5678)	1500 (5678)
Front 3" (L and K)	1500 (5678)	1500 (5678)	-	1500 (5678)
Front 4" (L and K)	-	-	2600 (9842)	-
Rear 3" (M and U)	1500 (5678)	1500 (5678)	-	1500 (5678)
Rear 4" (M and U)	-	-	2600 (9842)	-
Top 3" (C,D,E,F, and G)	1500 (5678)	1500 (5678)	1500 (5678)	1500 (5678)
Top 4" (A, H, and C)	1500 (5678)	2600 (9842)	2600 (9842)	2600 (9842)
Tank to Pump Line**				
Single 3" (S)	550 (2081)	600 (2271)	600 (2271)	600 (2271)
Single 4" (S)	1000 (3785)	1100 (4163)	1100 (4163)	1100 (4163)
Dual 3" (S and T)	-	1100 (4163)	1100 (4163)	1100 (4163)
Dual 4" (S and T)	-	1500 (5678)	1500 (5678)	1500 (5678)

Single Port Flow (Suction)***				
	Qflo Plus	Qmax	Qmax-XS	Qtwo
Side Single 5"	1000 (3785)	1000 (3785)	1000 (3785)	1000 (3785)
Side Single 6"	1250 (4731)	1500 (5678)	1500 (5678)	1500 (5678)
Front Side 3" (U and V)	300 (1135)	300 (1135)	300 (1135)	300 (1135)
Rear Side 3" (W and X)	300 (1135)	300 (1135)	300 (1135)	300 (1135)
Bottom w/Typical Front or Rear Piping	1000 (3785)	1000 (3785)	1000 (3785)	1000 (3785)
Rear "T" Suction w/ Typical Piping	-	1100 (4163)	1100 (4163)	1100 (4163)
Side Dual 6"	-	2000 (7570)	2000 (7570)	2000 (7570)
Side Triple 6"	-	2250 (8517)	2250 (8517)	-

* Performance is maximum with sufficient pressurized water source and horsepower.

** Based on sufficient tank venting, sump and baffle design and having a full flow straight connecting line/valve.

*** Based on NFPA 1901 Draft Testing Conditions assuming minimal piping or valving loss.

Qmax-XS

PORT DIAGRAM

TECHNICAL DATA

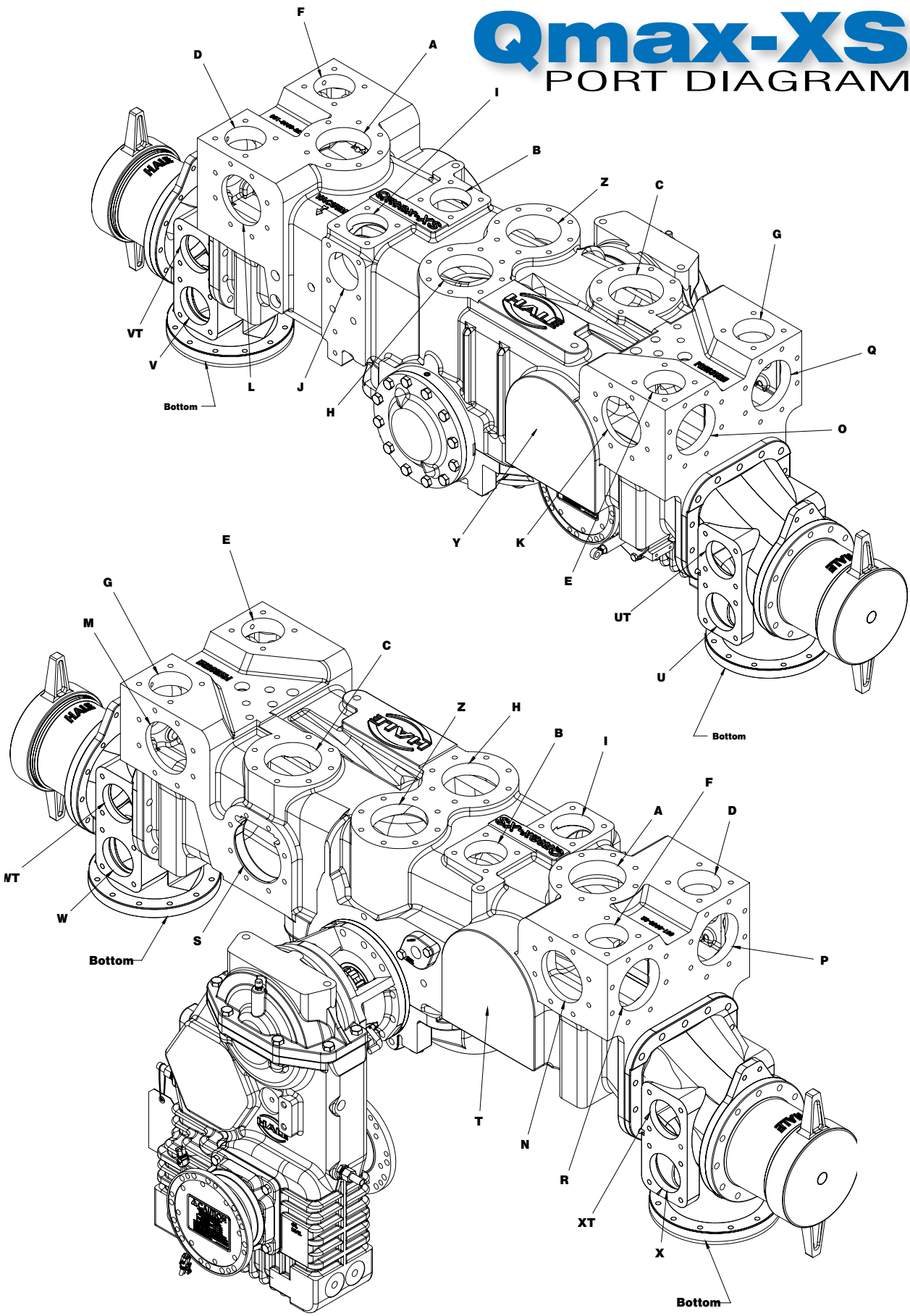

Qmax

PORT DIAGRAM

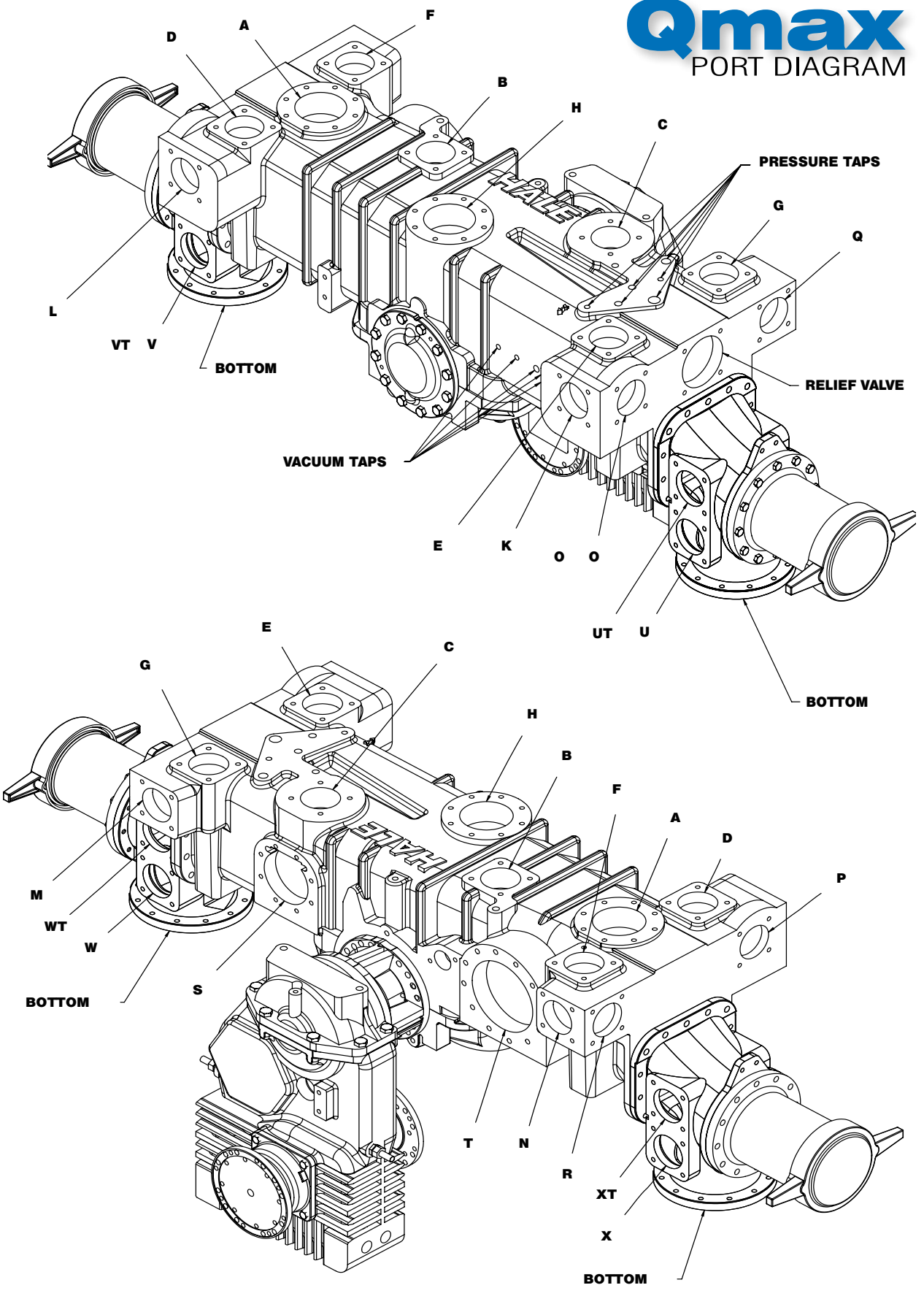

Qtwo

PORT DIAGRAM

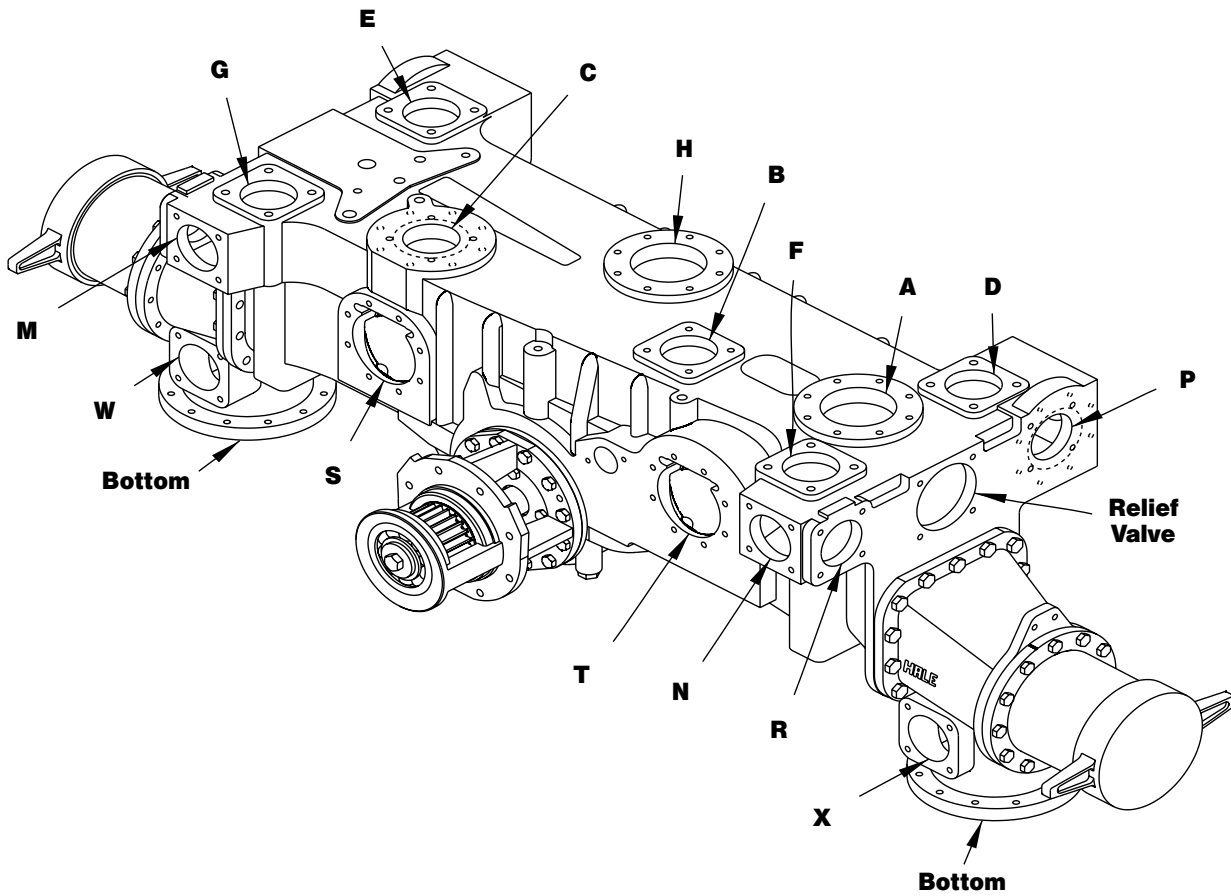
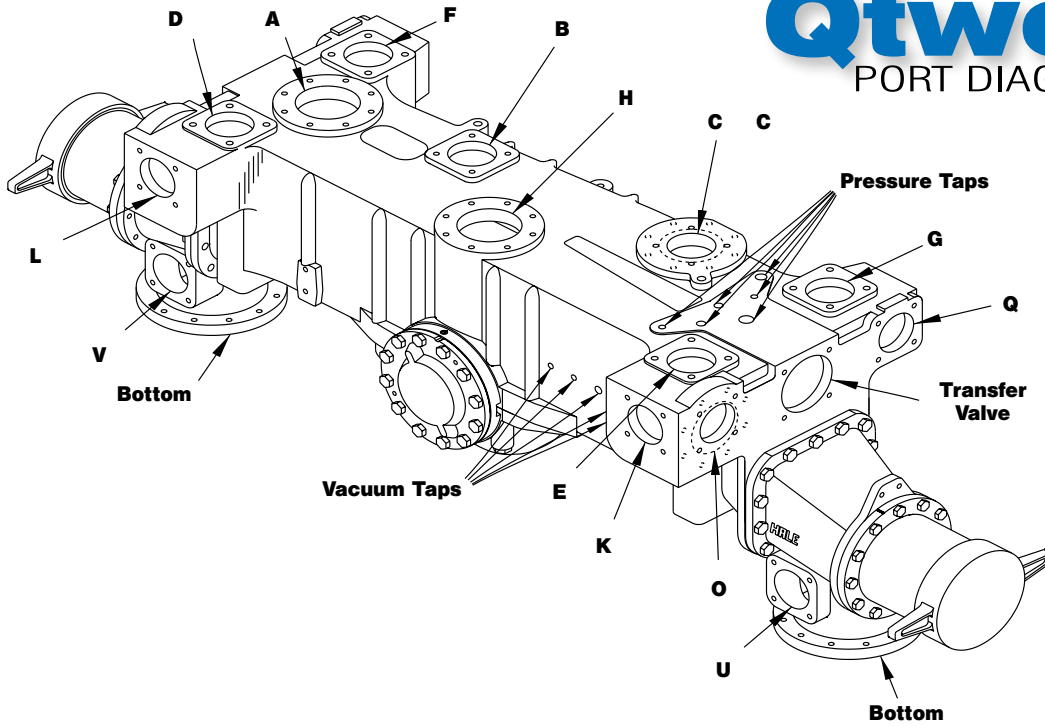



Qflo Plus

PORT DIAGRAM

HALE PRODUCTS INC | PH. 800.533.3569 | haleproducts.com

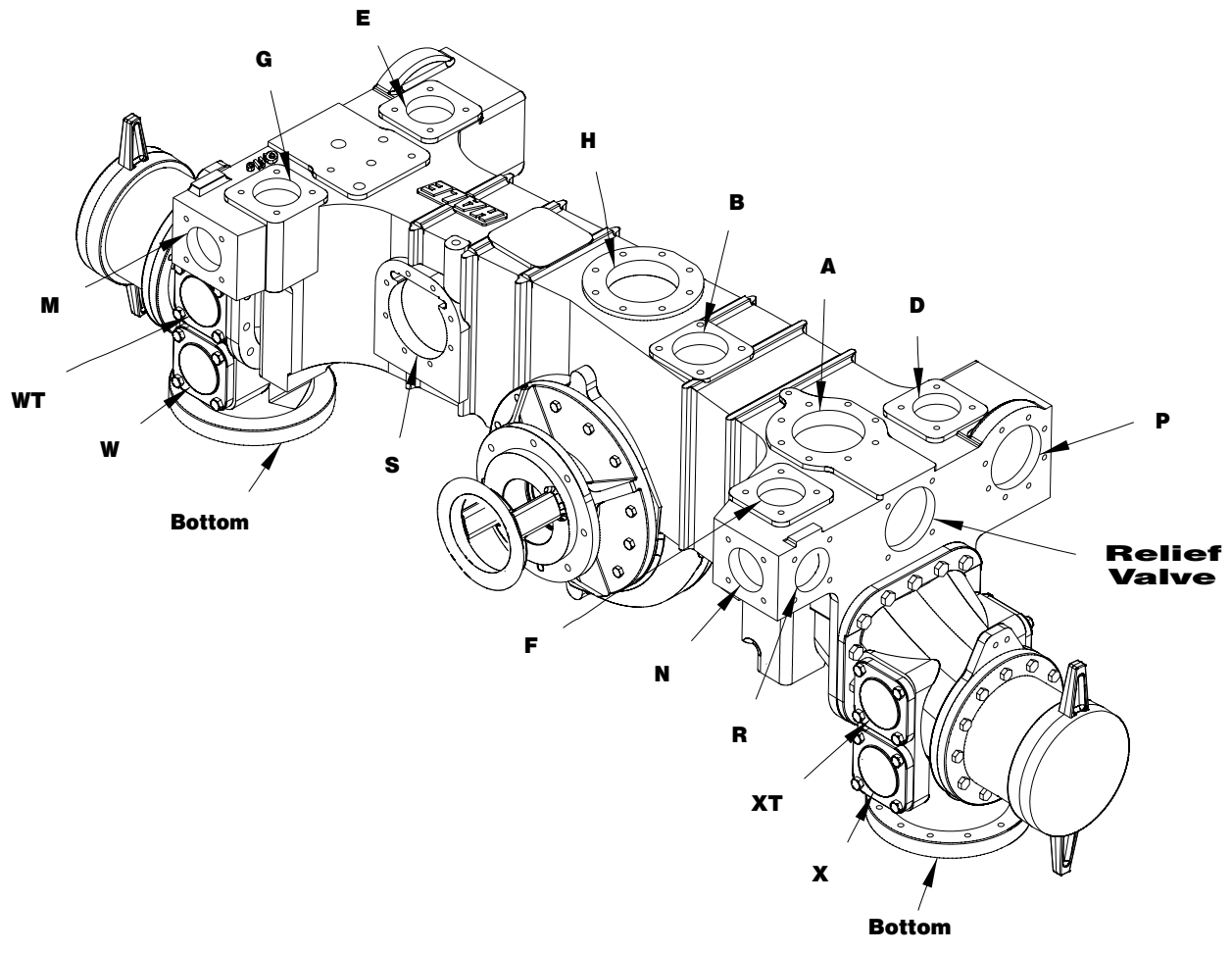
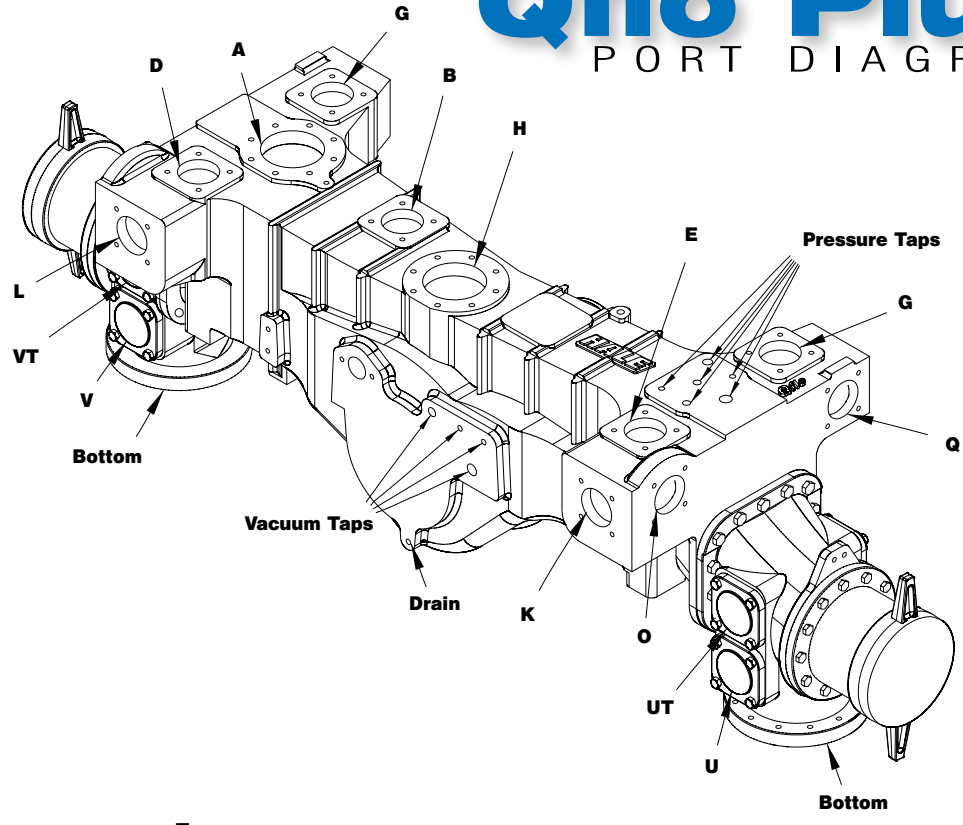

Pump Cross Reference Chart															
NFWA RATING															
STYLE	BRAND	250 (946)	500 (1892)	750 (2839)	1000 (3785)	1250 (4731)	1500 (5678)	1750 (6624)	2000 (7570)	2250 (8517)	2500 (9463)	2750 (10,409)	3000 (11,356)	3000+ (11,356+)	
Manifolded Split Shaft Manifolded Single stage	H			QFLO PLUS	QMAX QMAX-XS QFLO PLUS	QMAX QMAX-XS QFLO PLUS	QMAX QMAX-XS	QMAX QMAX-XS	QMAX QMAX-XS	QMAX QMAX-XS					
	W		CS	CS	CS	CS	CSU	CSU	CSU	CSU					
	D				LDM	LDM	LDM	LDM							
	H				QTWO	QTWO	QTWO	QTWO	QTWO	QTWO					
	W			CM	CM	CM	CMU	CMU	CMU	CMU					
	D				EM	EM	EM	EM	EM	EM					
Manifolded Split Shaft Non-Manifolded Single Stage	H	APMG	MG APMG	DSD MG	DSD MG	DSD	DSD 8F SERIES	8F SERIES	8F SERIES	8F SERIES	8F SERIES	8F SERIES	8F SERIES		
	W		CG	CX CG	CX	CX S100	CX S100	S100	S100	S100			CRU	CRU	
	D	KHM	KHM LSM	LSM	LSM PSM	PSM	PSM	PSM			ZSM	ZSM	ZSM	ZSM 2ZSM	
	H	CBP	AP MBP	RSD MBP	RSD MBP	RSD	RSD	RSD	RME	RME	RME	RME	RME	RME	DFG
	W	CPK-2	CL S200	CX CG S200	CX	CX S100	CX S100	CX S100	S100	S100					
	D	HR AG HM	HM HR KS LS	KS LS	KS LS PS	PS	PS	PS			ZS	ZS	ZS	ZS	
PTO Non-Manifolded Two Stage	H		TBP	TBP	TBP									DFG	
	W	CPK-3	CPK-3												
	D	JMP	JMP												
PTO Non-Manifolded Multi-pressure	H	KP1/KP2	Prima P1/P2 KP1/KP2	Prima P1/P2	Prima P1/P2	Prima P1/P2									
	W	HL	HL	HL	HL	HL									
	D														



PowerFlow HP Pump NFPA 1906 Selection Guide

The following PowerFlow HP Series portable pumps are capable of meeting the Wildland Fire Apparatus rated capacities shown in accordance with the 2016 edition of NFPA 1906

50 gpm @ 100 psi	50 gpm @ 150 psi	50 gpm @ 250 psi	150 gpm @ 100 psi
HP75-YD9	HP200-B18	HP70-B18	HP200-B23
HP300-B18	HP200-B23	HP100-B23	HP200-KBD24
HP400-B18	HP200-KBD24	HP100-KBD24	HP275-B35
HP400-B23	HP275-B35		HP300-B23
			HP300-KBD24
			HP350-KBD39
			HP450-B35

Refer to individual performance curves on page 87-88

PowerFlow HP Pump Performance Application Guide

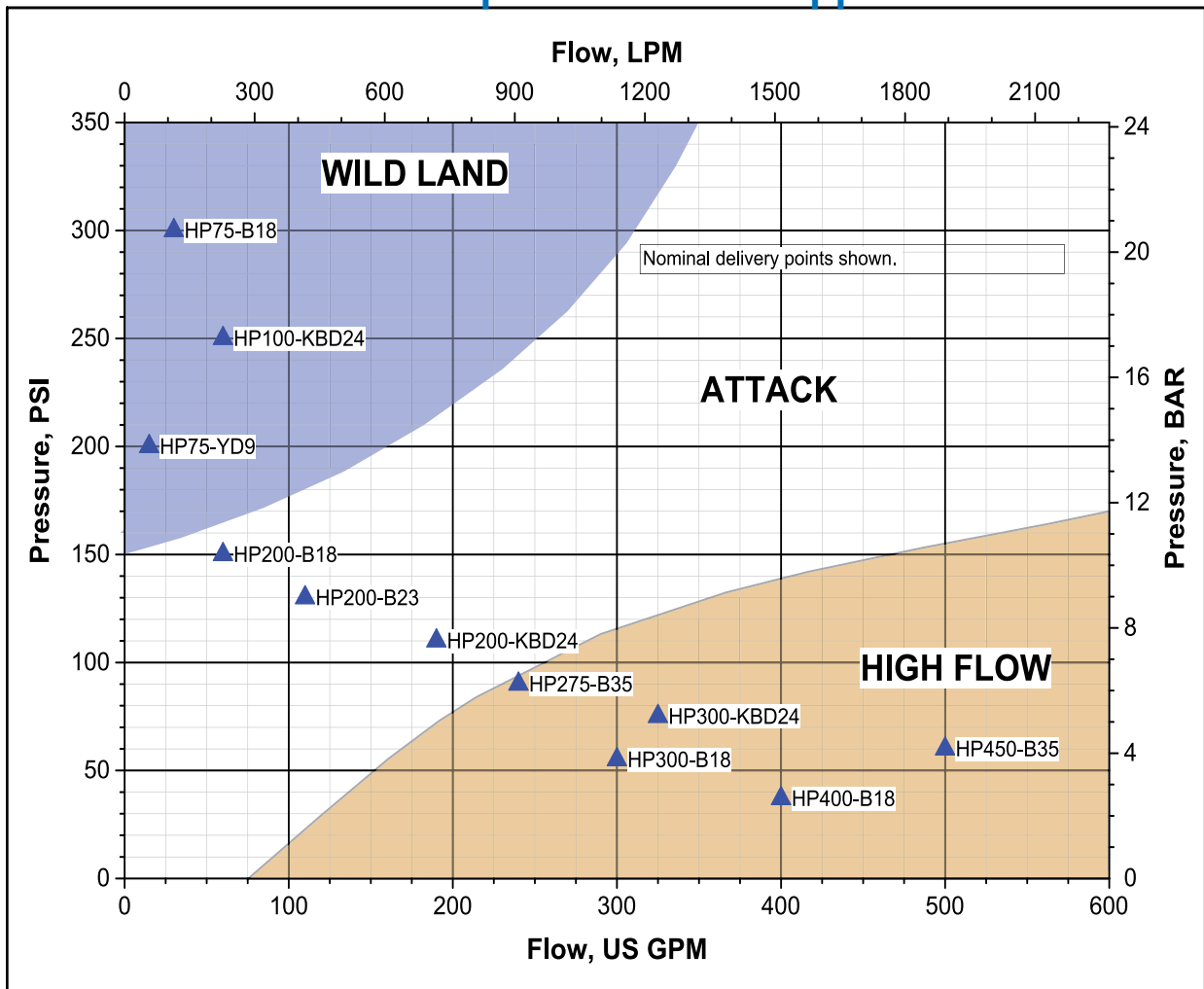



20FP-C8 20FV-C8 Fyr Flote Pump Performance

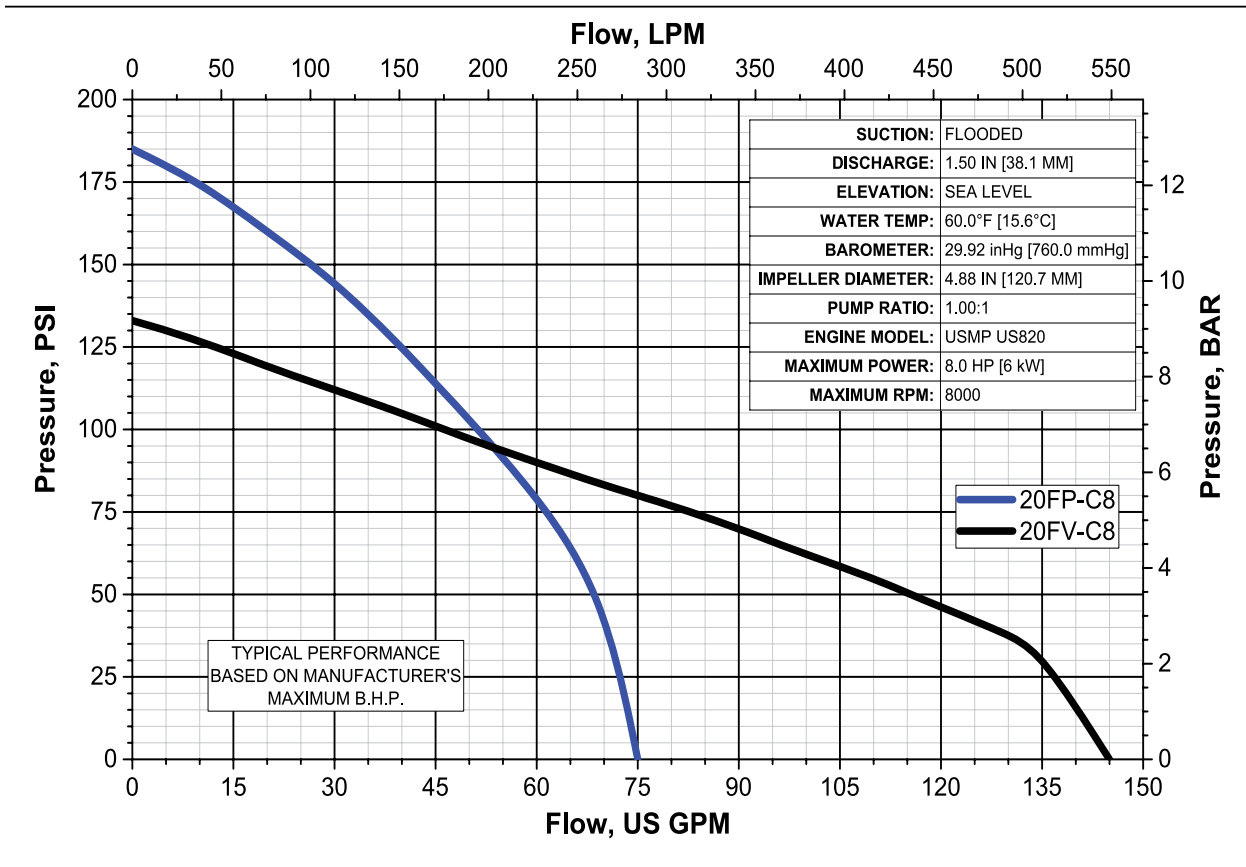

20FP-C8P Fyr Pak Pump Performance

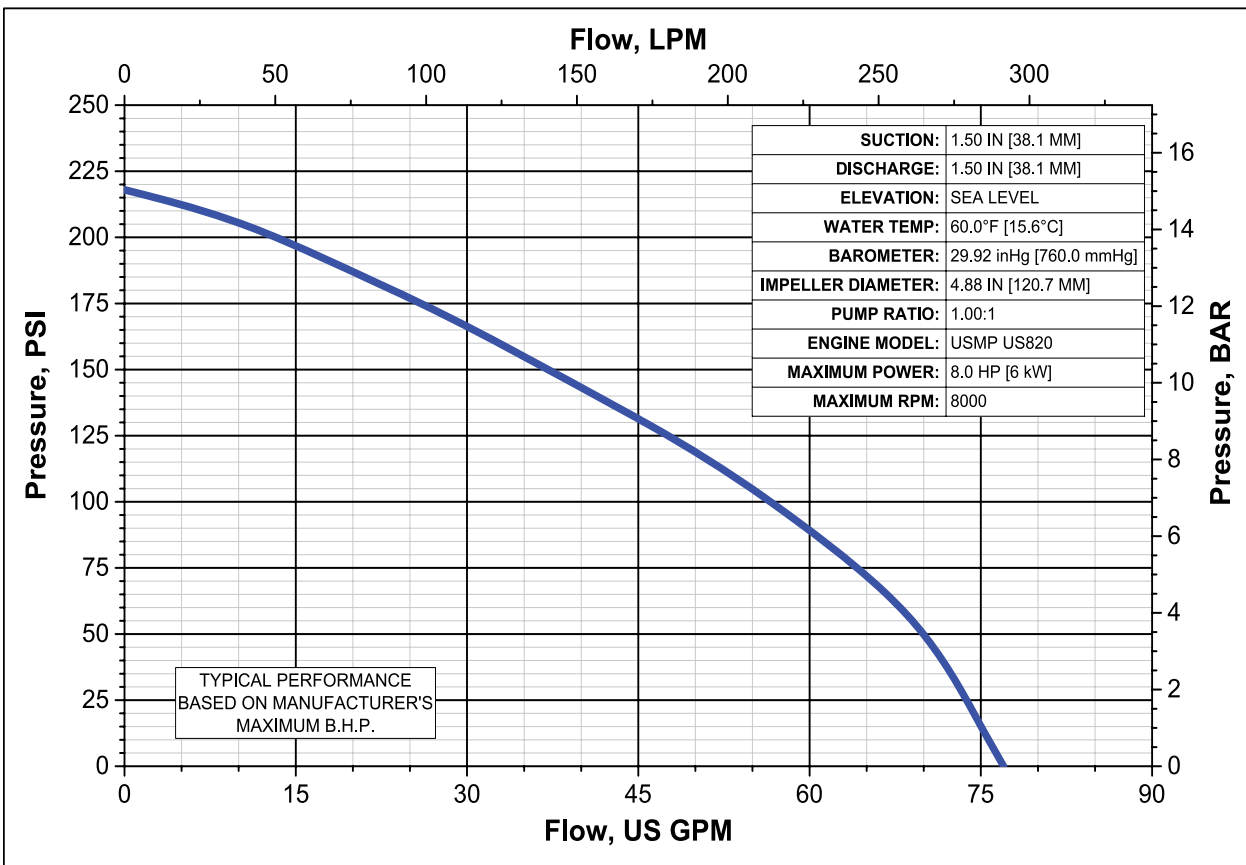



PowerFlow HP Gasoline Performance Range Curve

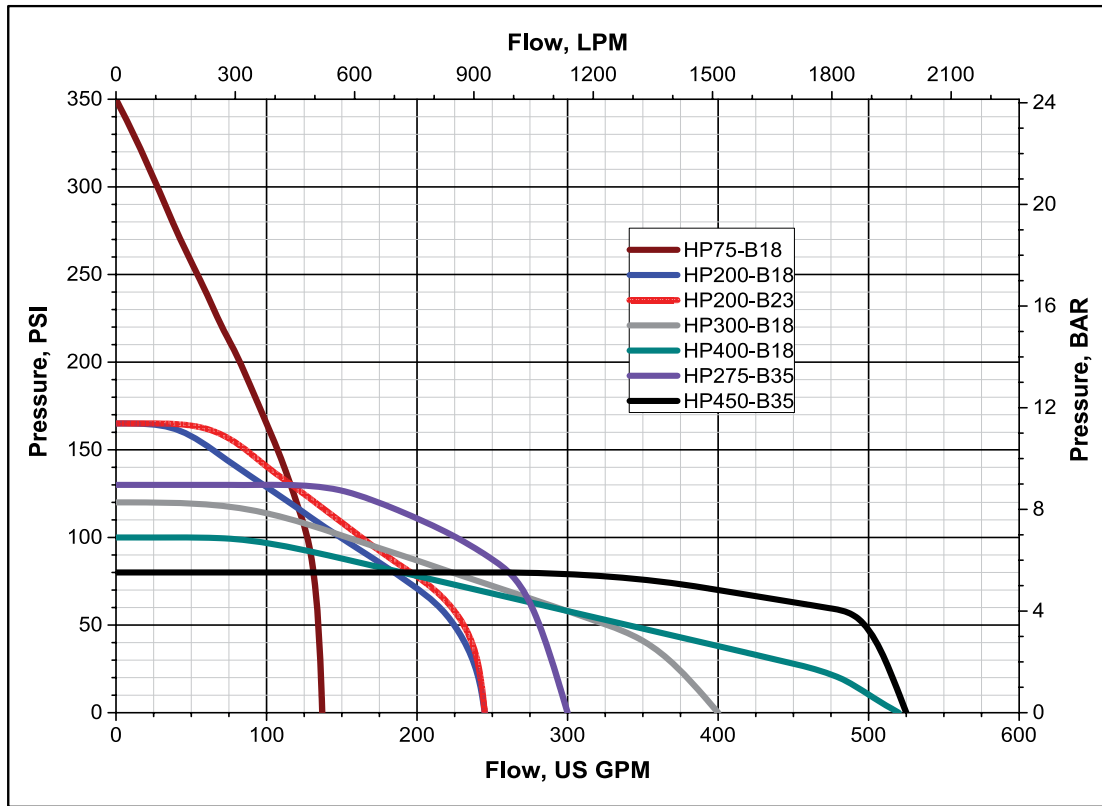

PowerFlow HP Diesel Performance Range Curve

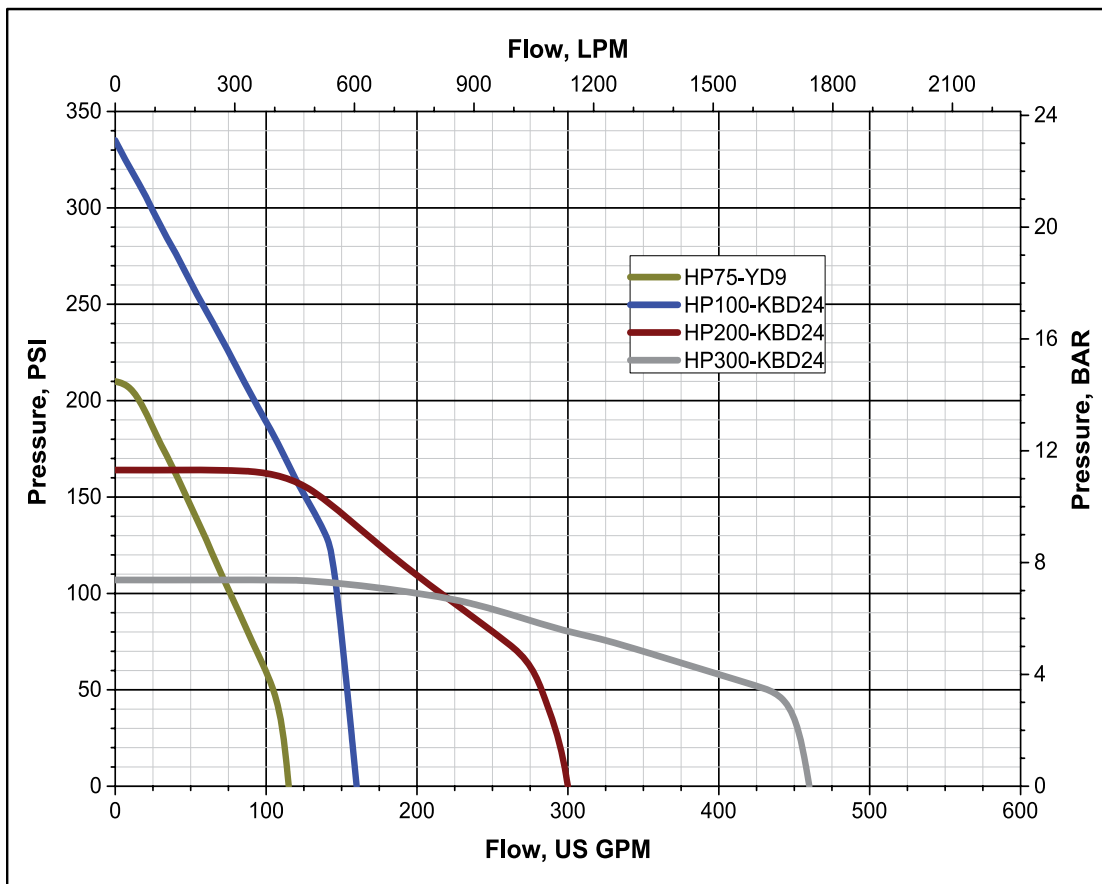

Determining which Foam system will meet your needs

Maximum possible Foam Solution

Model (12 or 24 Volt)	Max Foam Flow Rate GPM	Max Injection Pressure (PSI)	Max Water Flow - GPM					
			Class A Foam Injection Rate				Class B Foam Injection Rate	
			0.1%	0.3%	0.5%	1%	3%	6%
1.7	1.7	400	1700	566	340	170	Class A Only	
2.1	2.1	250	2100	700	420	210		
3.3	3.3	400	3300	1100	660	330	110	55
5.0	5.0	250	5000	1666	1000	500	166	83
6.5	6.5	200	6500	2166	1300	650	216	108
Dual 6.5	13.0	200	13,000	4333	2600	1300	433	216

Maximum Number of Handlines

Number of Handlines at 0.3%	Handline Flow - GPM			
	100	150	250	350
1.7 AHP	5	3	2	1
2.1 A	7	4	2	2
3.3	11	7	4	3
5	16	11	6	4
6.5	21	14	8	6
Dual 6.5	43	28	17	12

Recommended Foam Piping Size

Flowmeter Piping Size (in.)	Minimum Flow of Piping - GPM	Maximum Flow of Piping - GPM
1.5"	10	350
2"	20	550
2.5"	30	800
3"	50	1250
4"	75	1800

SmartATP System Layout

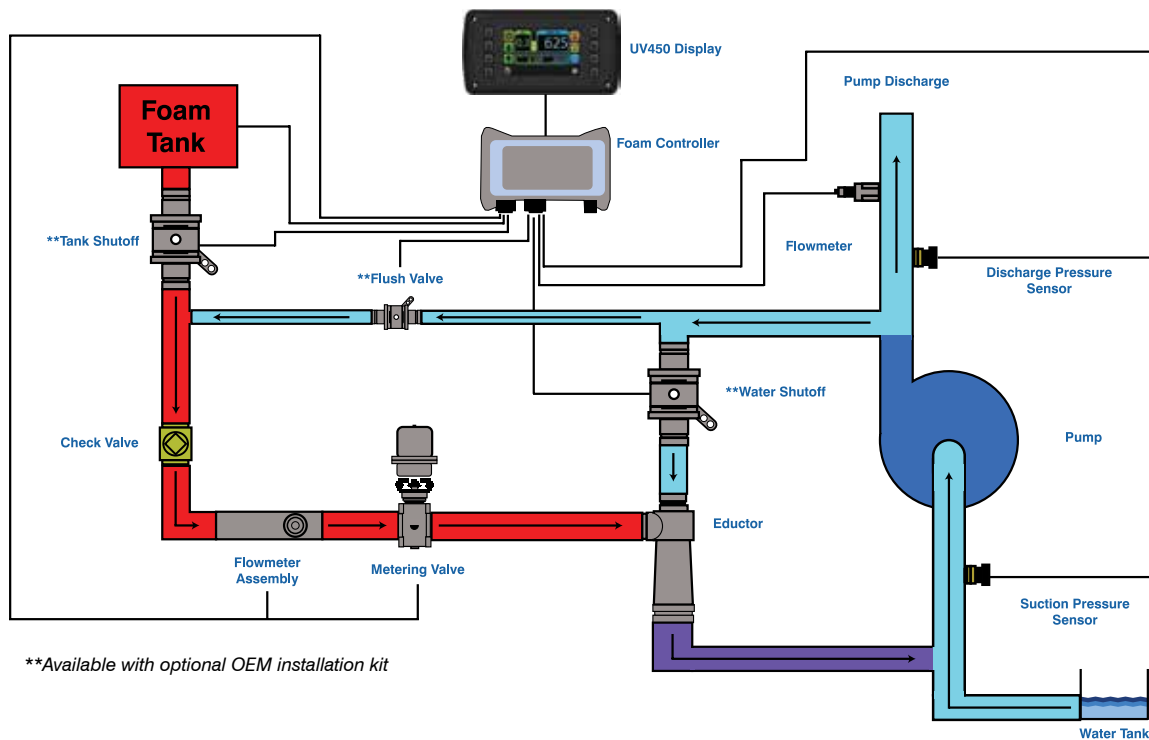

**Available with optional OEM installation kit



Determining which Foam system will meet your needs

To determine which SmartFOAM system will best meet your apparatus needs, you must first determine the maximum solution flow you will use while flowing foam. Do this by multiplying the number of foam capable discharges you plan to simultaneously use by the typical water flow of each. Next, determine the maximum foam injection rate you plan to use with the system. Then choose the correct system table: "Table 1: Class A foam only" or "Table 2: Class A and/or B foam".

For example, if you plan to use three (3) foam discharges and each will run at 125 GPM then the total solution flow (water and foam) will be 375 GPM. If you will be using Class A foam only and at a maximum rate of 0.6% then the minimum sized SmartFOAM system you should choose is a 3.3 (from Table 1: Class A foam only). Keep in mind that these tables are used to determine the MINIMUM sized system. If the chart shows that a 3.3 system is the minimum sized system there is no issue in choosing one of the next sizes up (5.0, 6.5, or Dual 6.5). The maximum injection pressure value indicates the maximum pressure that the system can operate against. Please keep this in mind when choosing the system.

Table 1: Class A foam only

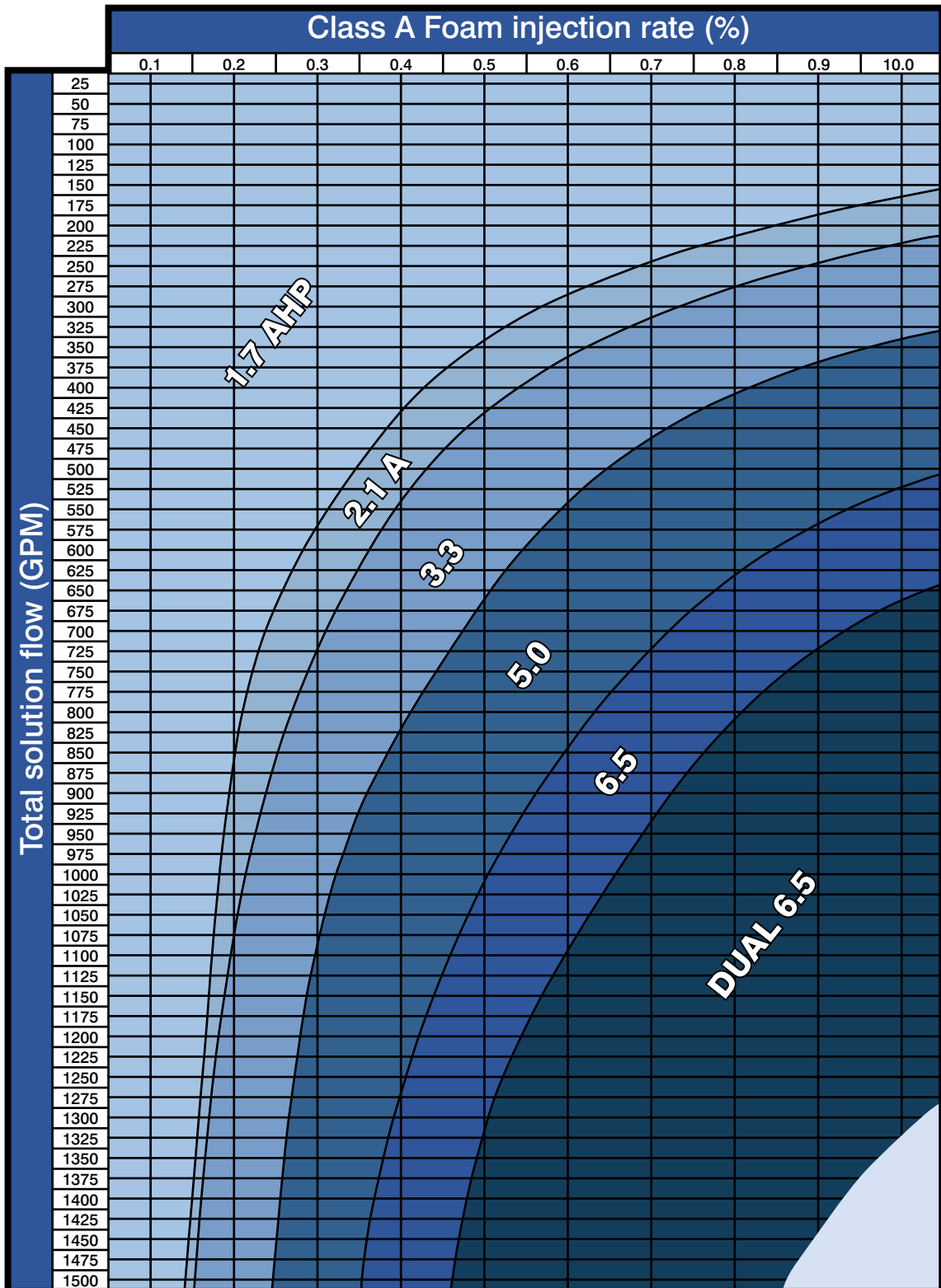
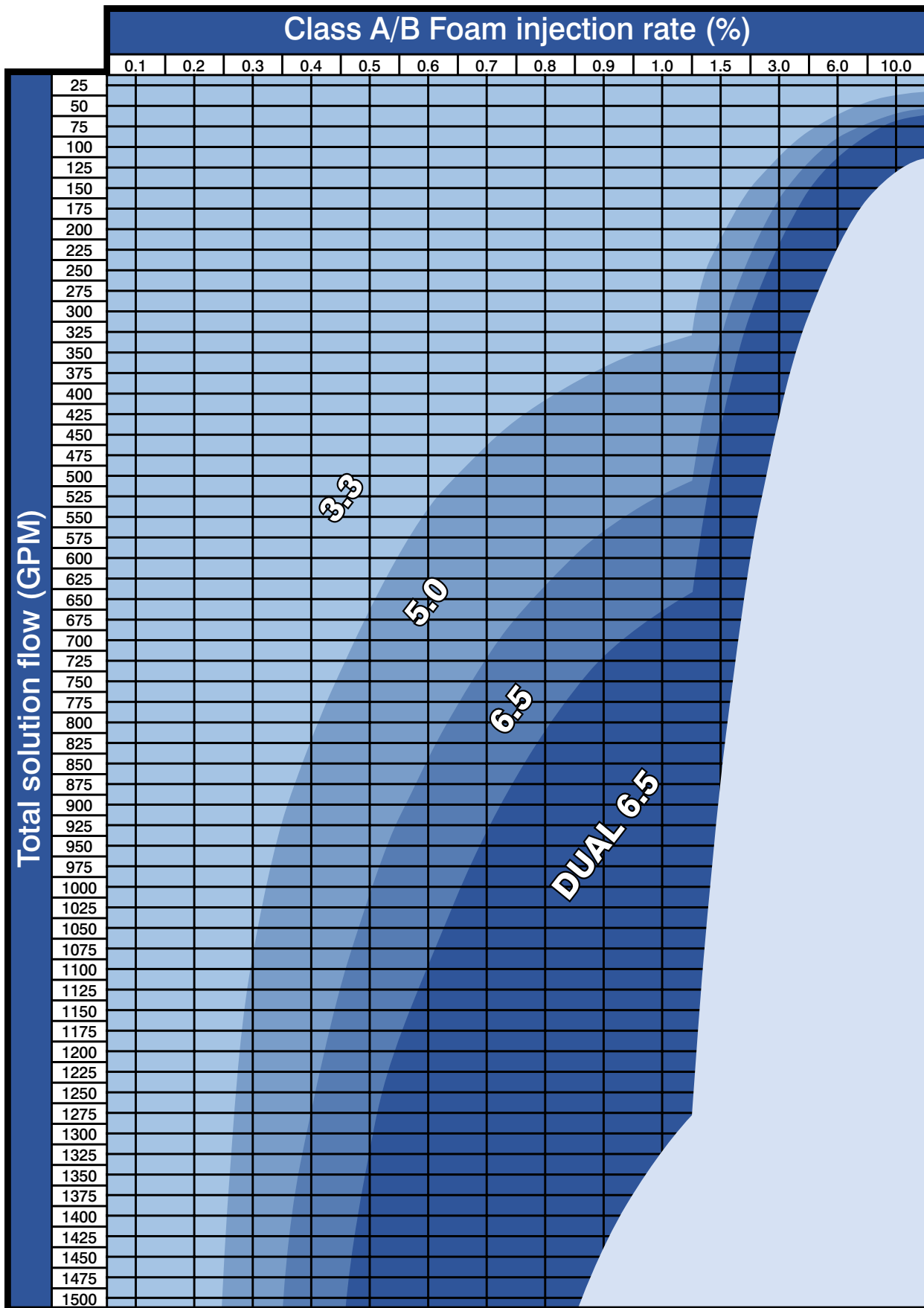

Table 2: Class A and/or B foam





Metric Conversion Chart

HALE PRODUCTS INC | PH. 800.533.3569 | haleproducts.com

Liquid Volume		
To Convert	Into	Multiply by
Ounces (oz)	Milliliters (ml)	29.57
Pints (pt)	Liters (l)	0.4732
Quarts (qt)	Liters (l)	0.9464
Gallons (gal)	Liters (l)	3.785
Milliliters (ml)	Ounces (oz)	0.0338
Liters (l)	Pints (pt)	2.113
Liters (l)	Quarts (qt)	1.057
Liters (l)	Gallons (gal)	0.2642
Pressure		
To Convert	Into	Multiply by
Pounds per square inch (psi)	Kilopascals (kPa)	6.895
Pounds per square inch (psi)	bar	0.06895
Kilopascals (kPa)	Pounds per square inch (psi)	0.145
Kilopascals (kPa)	bar	0.01
bar	Pounds per square inch (psi)	14.503
bar	Kilopascals (kPa)	100
Length		
To Convert	Into	Multiply by
Inches (in)	Millimeters (mm)	25.4
Inches (in)	Centimeters (cm)	2.54
Feet (ft)	Centimeters (cm)	30.48
Feet (ft)	Meters (m)	0.3048
Yards (yd)	Meters (m)	0.914
Miles (mi)	Kilometers (km)	1.609
Millimeters (mm)	Inches (in)	0.039
Centimeters (cm)	Inches (in)	0.394
Meters (m)	Feet (ft)	3.282
Kilometers (km)	Miles (mi)	0.6214
Area		
To Convert	Into	Multiply by
Square Inches (in ²)	Square Centimeters (cm ²)	6.452
Square Feet (ft ²)	Square Meters (m ²)	0.093
Square Yards (yds ²)	Square Meters (m ²)	0.836
Square Miles (mi ²)	Square Kilometers (km ²)	2.59
Square Centimeters (cm ²)	Square Inches (in ²)	0.155
Square Meters (m ²)	Square Yards (yds ²)	1.196
Square Kilometers (km ²)	Square Miles (mi ²)	0.386
Hose Sizes		
1" Hose	=	25.4 mm
1 1/2" Hose	=	38.1 mm
1 3/4" Hose	=	44.5 mm
2" Hose	=	50.8 mm
2 1/2" Hose	=	63.5 mm
3" Hose	=	76.2 mm
3 1/2" Hose	=	88.9 mm
Tip Sizes		
3/4" Tip	=	19 mm
7/8" Tip	=	22 mm
1" Tip	=	25 mm
1 1/8" Tip	=	29 mm
1 1/4" Tip	=	32 mm
1 3/8" Tip	=	35 mm

Solid Volume		
To Convert	Into	Multiply by
Ounces (oz)	Grams (g)	28.3495
Pounds (lb)	Kilograms (kg)	0.4536
Grams (g)	Ounces (oz)	0.035
Kilograms (kg)	Pounds (lb)	2.205
Pressures		
50 psi	=	345 kPa
60 psi	=	414 kPa
70 psi	=	488 kPa
75 psi	=	517 kPa
80 psi	=	552 kPa
90 psi	=	621 kPa
100 psi	=	690 kPa
150 psi	=	1034 kPa
200 psi	=	1379 kPa
250 psi	=	1723 kPa
300 psi	=	2069 kPa
350 psi	=	2413 kPa
580 psi	=	3999 kPa
700 psi	=	4827 kPa
Flow		
Flow Rate		Exact LPM
12 gpm	=	45.42 lpm
13 gpm	=	49.20 lpm
15 gpm	=	56.78 lpm
20 gpm	=	75.70 lpm
23 gpm	=	87.06 lpm
25 gpm	=	94.62 lpm
30 gpm	=	113.55 lpm
40 gpm	=	151.40 lpm
50 gpm	=	189.25 lpm
60 gpm	=	227.10 lpm
70 gpm	=	264.95 lpm
75 gpm	=	283.88 lpm
85 gpm	=	321.73 lpm
95 gpm	=	359.58 lpm
100 gpm	=	378.50 lpm
120 gpm	=	454.20 lpm
125 gpm	=	473.13 lpm
150 gpm	=	567.75 lpm
175 gpm	=	662.38 lpm
200 gpm	=	757.00 lpm
250 gpm	=	946.25 lpm
300 gpm	=	1135.50 lpm
350 gpm	=	1324.75 lpm
375 gpm	=	1419.38 lpm
400 gpm	=	1514.00 lpm
450 gpm	=	1703.25 lpm
500 gpm	=	1892.50 lpm
550 gpm	=	2081.75 lpm
700 gpm	=	2649.50 lpm
750 gpm	=	2838.75 lpm
800 gpm	=	3028.00 lpm
1000 gpm	=	3785.00 lpm
1200 gpm	=	4542.00 lpm
1250 gpm	=	4731.25 lpm
1500 gpm	=	5677.50 lpm
2000 gpm	=	7570.00 lpm

Alphabetical Index

3/4" Air Drain	58	ENFO IV	36
3/4" Automatic Drain	58	ESP (Environmentally Safe Priming) System	13
2CBP	8	EZ-Fill Foam Reservoir Refill System	49
80FC Duramax Engine Driven Unit	26		
80FC	18	F	
80FCG	18	Fill Thief	50
80FCK	18	Filled Pressure Gauges	52
8FG	18	Flange – 115 x 115	68
8FK	18	Flange – 115 x Weld	68
		Flange – 12-Bolt x Groove	70
A		Flange – 8-Bolt Cap	70
Adapters	62	Flange – 8-Bolt x Groove	70
Air Brake Tubing	63	Flange – 8-Bolt x Weld	70
Air Dual Foam Tank Selector	49	Flange – 8-Bolt	70
Air Operated Cylinders	63	Flange – Valve x 115	67
Anode	12	Flange – Valve x FNPT	67
AnodePro	12	Flange – Valve x Groove	66
AP	8	Flange – Valve x Hose	66
AP/MBP Discharge	71	Flange - Valve x Weld	66
Around The Pump Proportioner	48	Flange -115 x Groove	68
Attack Firefighting Pumps	41	Flange -115 x NPT	68
AutoFill	50	Floating Pumps	39
Automatic Master Drains	58	Foam Accessories	49
		Foam Refill System	50
B		Foam Systems	44-50
Backpack Pumps	39	Fyr Flote	39
Ball Valve.....	59, 73	Fyr Pak	39
Bell Cranks	76		
		G	
C		Gauge Ordering Information	55
CAFS	46, 47	Gauge	52-55
Caps	62	Godiva Pumps	15-16
Captain	35	Grooved End Pipe Couplings	61
CBP	8		
Check Valves	69	H	
Chrome Plate Gauge Bezels	54	Handles & Levers	74
Class A and B Foam Pumps	45	High Flow Pumps	18-20
Class A Foam Pumps	44	High Flow Pumps	42
Class A Foam	44	High Pressure Flexible Coupling	60
Class B Foam	45	High Pressure Flexible Piping	60
Colored Gauge Bezels	54	High Pressure Strainer	50
Control Assemblies	57	High Pressure/Low Volume Pumps	40
Control Rod Ends	76	HPT200-B18	41
		HPT300-B18	42
D		HPT400-B18	42
DFG	19	HPT75-B18	40
Direct Injection Foam Systems	44-50	HPX200-B18	41
Drain Valves	58	HPX200-B23	41
Drains	58-59	HPX200-H20	41
DSD Discharge	71	HPX200-KBD24	41
DSD Kit	30	HPX275-B35	42
DSD	9	HPX300-B18	42
Duplex Gauges	53	HPX300-KBD24	42
Duramax	26	HPX400-B18	42
		HPX450-B35	42
E		HPX75-B18	40
Elbows	75	HPX75-B23	40
Electronics (Pressure Governors)	32-36	HPX75-KBD24	40
ENFO III	36	HPX75-YD9	40

I

Industrial High Flow Pumps	18-20
Intake Relief Valve	69
ITL-4	36
ITL-40	36

K

KP1	16
KP2	16

L

LGA	23
Lighted Pressure Gauges	53
LKA	23
Low Pressure Strainer	50
Low Pressure/High Volume	42

M

Manifolded Discharge	71-72
Manifolded Pumps	4-5
Manifolds	71- 73
Manual Dual Foam Tank Selector	49
Manual Master Drains	58
Manual Single Foam Tank Selector	49
Marine	26
MBP	9
Medium Pressure/Medium Volume Pumps	41
MG	9
MGA	23
MIV	12
Mixer	69
Modules	28
Mounting Brackets	74

N

Non-Manifolded Pumps	7-9
----------------------------	-----

O

O-Rings & Gaskets	69
-------------------------	----

P

Petcock Valve	59
Piping & Coupling	59-61
Plugs	62
Plumbing Accessories	66-76
Plumbing Brackets	74
Plumbing	56-76
Portable Adapter	73
Portable Discharge	72
Portable Pumps	38-42
Portable Suction Manifold	72
Press Relief Valve	11
Pressure Gauges	52-55
Pressure Governors	32-36
Prima P1	16
Prima P2	16

Primers	13
Pump Accessories	11-13
Pump Modules & Kits	28-30
Push-on Fittings	64-65
Push-Pull Controls	57

Q

QC Test Kits	54
Qflo-Plus	5
Qmax Kit	30
Qmax	5
Qmax-XS	5
Qtwo	5

R

RGA	23
RME	18
RSD	9

S

Safe Buy	28
Sentry	33
Shift Interlock Module	12
Side Kick	29
Skids & Trailers	25
SmartATP	48
SmartCAFS	46, 47
SmartFOAM	44
Special Pump Applications	25-26
Split Shaft Gearboxes	23
Stainless Steel Swivels	59
Super Chief	39
Swift Handles	57

T

TBP	9
Tees	68, 75
Tees	68, 75
Test Port Adapters	58
Top Mount Controls	57
TPG	34
TPG+	34
TPM – Total Pressure Master	11
TRV11	
Twister – Electronic Vernier Throttle	35

V

Vacuum Gauges	52-55
Valve Adapters/Valve Ends	66-70

W

Weld Adapters	75
Wildland Firefighting Pumps (High Pressure/Low Volume)	40

Y

Yokes	76
-------------	----



Customer Support

From our global sales team to our customer service and technical support staff, we endeavor to provide peace of mind for you, no matter what the location in the world.

Ocala, Florida, USA Headquarters:

Customer Support and Technical Assistance representatives are available Monday through Friday 8:00 A.M. – 6:00 P.M. EST.

Hale Products: 800-533-3569 | (352) 629-5020

Contact Customer Service for:

- Product orders
- Order tracking
- Pricing and availability (part numbers required)
- Part inquiries (for existing products only)
- Customer requested returns

Contact Technical Support for:

- Product troubleshooting
- Technical data such as product manuals, specifications, drawings
- Warranty
- Legacy parts
- Part identification

How to Order:

Customers: Looking for pricing and availability on loose equipment or parts? Contact one of our authorized distributors or Factory Authorized Service Team (FAST) partners. Visit haleproducts.com to locate a FAST or distributor near you.

Distributors / OEMs: Send your orders to haleorders@idexcorp.com

How to return your product for Service & Warranty Evaluation:

All products being returned for credit require prior authorization through our RMA process. Submit your request online at www.haleproducts.com/customer-support-returns/ or contact customer service for return authorization.

Hale Training Academy

This 4-Day training event addresses the following topics:

- Preventative maintenance
- Basics on midship pump design and construction
- Hands-on training on various pump components including the gearbox, impeller assembly, and pressure relief valve
- Detailed information on proper relief valve settings, pump installation inspections, and NFPA 1911 pump service testing
- Troubleshooting techniques
- CAFS/Foam training
- Class1 Electronics training

Students may also elect to register with the EVT Certification Commission (www.evtcc.org) to take one EVT exam at the conclusion of the training.

Learn more about the upcoming Hale Training Academies or register online at haleproducts.com

Follow us on:



The employees of HALE strive every day to design, machine, assemble and test our products and be your trusted partner in fire suppression delivery systems.



For more information on Hale Products warranties, visit our website at:
<https://www.haleproducts.com/resources/customer-service-and-legal-documents/>



Hale is ISO 9001: 2015 registered from NQA (National Quality Assurance, USA).
Certificate number 12513. This achievement attests to our commitment
to provide high quality products and services.

© 2018 Hale Products. All rights reserved. ES-KEY®, CLASS 1®, HALE® TORRENT®, SmartFOAM®, TORRENT®, FOAMLOGIX®, EZFILL®, SMARTCAFS®, TWISTER®, AnodePro®, QMAX®, TOUCH®, SIDE KICK®, SWIFT HANDLE®, ULTRAVIEW®, TYPHOON®, FYR PAK®, FYR FLOTE®, GODIVA®, SmartATP®, SmartRTP® and the Hale Logo are registered and unregistered trademarks of Hale Products. All other trademarks are the properties of their respective owners.



Hale, founded in 1914 by three Pennsylvania firefighters who believed they could build a better fire pump, is a worldwide marketer and manufacturer of fire and rescue equipment. The company has grown over its 100+ year history through new product innovation and strategic acquisitions to supply pumps, pump modules, foam systems, compressed air foam systems (CAFS), and electronic controls around the globe.

Today, Hale along with Akron Brass, AWG, Class1, Dinglee, Hurst, Godiva, Lukas, Vetter and Weldon combine to form IDEX Fire & Safety bringing you high quality, comprehensive solutions to solve mission critical problems, save lives, and better the world in which we live.

When seconds count, you can count on IDEX Fire & Safety.

