

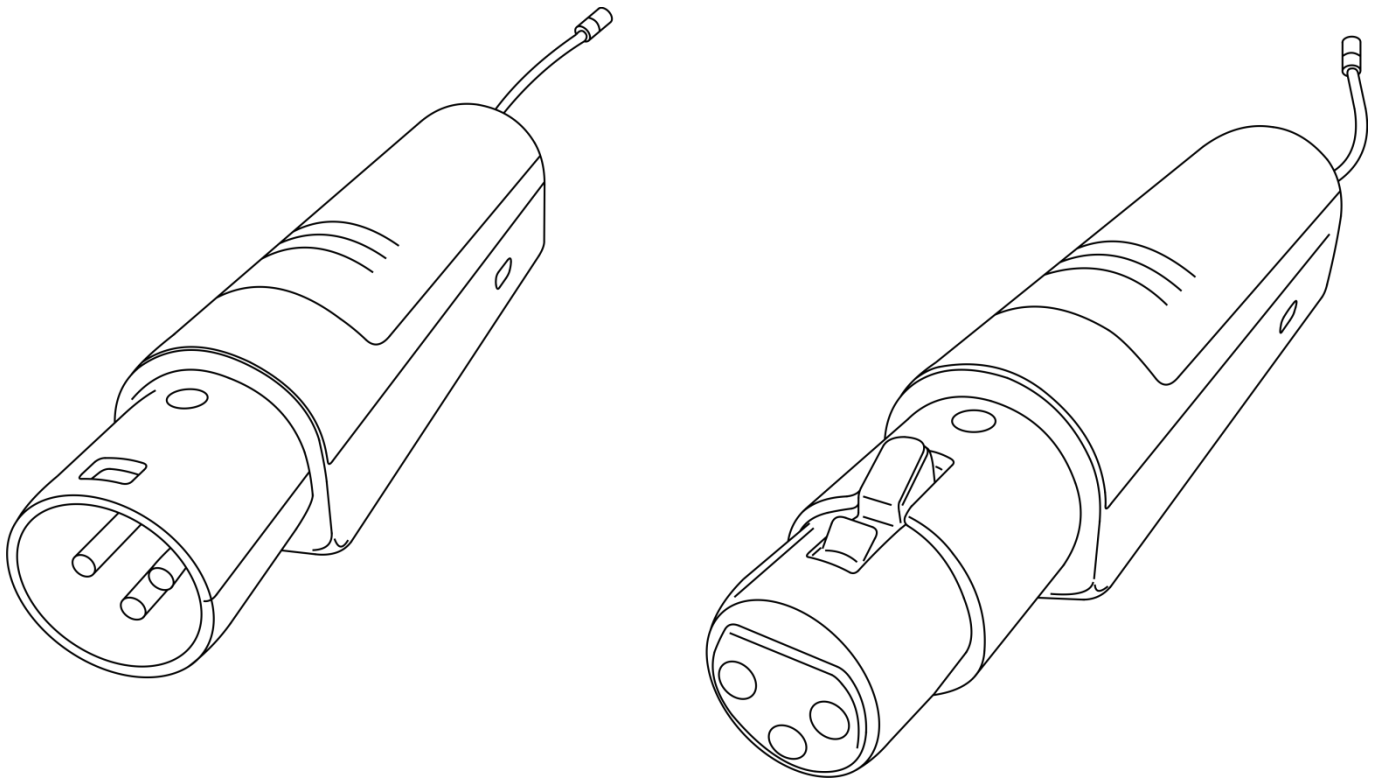

MANUAL



ENGLISH

COM-ART

V2

Ordercode: D1414

Table of contents

Warning	2
Unpacking Instructions.....	2
Safety Instructions	2
Operating Determinations	4
Return Procedure.....	5
Claims.....	5
Description of the device	6
Features	6
Frontside.....	7
Backside	7
Installation	8
Power Supply	8
Replace the Battery	8
Set Up and Operation	9
Location.....	9
Connection	9
Power On/Off	10
Battery Indicator	10
Operation.....	10
Frequency Range	10
Connection Cables	11
Maintenance	12
Product Specifications	12
Dimensions	13
Notes	14

Warning



**For your own safety, please read this user manual carefully
before your initial start-up!**



Unpacking Instructions

Immediately upon receiving this product, carefully unpack the carton and check the contents to ensure that all parts are present and have been received in good condition. Notify the dealer immediately and retain packing material for inspection if any parts appear damaged from shipping or the carton itself shows signs of mishandling. Save the carton and all packing materials. In the event that a fixture must be returned to the factory, it is important that the fixture be returned in the original factory box and packing.

Your shipment includes:

- DAP Audio COM-AT (transmitter)
- DAP Audio COM-AR (receiver)
- 2 cables mini-USB to USB A
- User manual

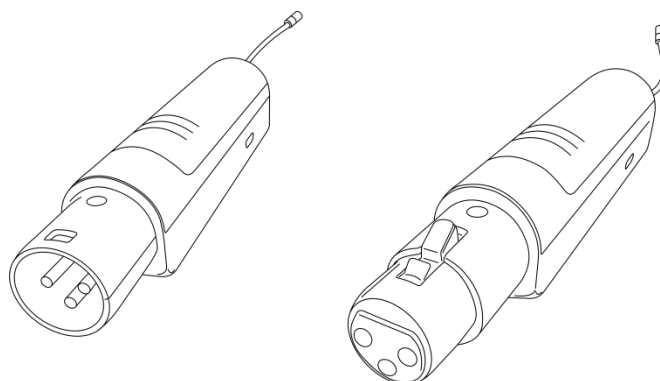

CAUTION!

**Keep this device away from rain and moisture!
Unplug mains lead before opening the housing!**



Safety Instructions

Every person involved with the installation, operation and maintenance of this system has to:

- be qualified
- follow the instructions of this manual



**CAUTION! Be careful with your operations.
With a dangerous voltage you can suffer
a dangerous electric shock when touching the wires!**



Before your initial start-up, please make sure that there is no damage caused by transportation. Should there be any, consult your dealer and do not use the device.

To maintain perfect condition and to ensure a safe operation, it is absolutely necessary for the user to follow the safety instructions and warning notes written in this manual.

Please consider that damages caused by manual modifications to the device are not subject to warranty. This device contains no user-serviceable parts. Refer servicing to qualified technicians only.

IMPORTANT:

The manufacturer will not accept liability for any resulting damages caused by the non-observance of this manual or any unauthorized modification to the system.

- Always let the device cool down before cleaning or servicing.
- Always disconnect power from the mains, when system is not used. Only handle the power cord by the plug. Never pull out the plug by tugging the power cord.
- Always operate the unit with the AC ground wire connected to the electrical system ground.
- Avoid flames and do not put close to flammable liquids or gases.
- Avoid ground loops! Always be sure to connect the power amps and the mixing console to the same electrical circuit to ensure the same phase!
- Before changing the ground, always turn off your amplifier.
- Connecting amplifier outputs to oscilloscopes or other test equipment, while the amplifier is in bridge mode, may damage both, the amplifier and test equipment.
- Do not connect this device to a dimmer pack.
- Do not drive the inputs with a signal level higher than required to drive the equipment to full output.
- Do not insert objects into air vents.
- Do not open the device and do not modify the device.
- Do not open this device. Risk: hazardous radiation exposure.
- Do not switch the system on and off in short intervals, as this would reduce the system's life.
- Do not put your equipment next to TV, radio, etc., because of interference or distortion.
- If device is dropped or struck, disconnect mains power supply immediately. Have a qualified engineer inspect for safety before operating.
- If the system has been exposed to drastic temperature fluctuation (e.g. after transportation), do not switch it on immediately. The arising condensation water might damage your system. Leave the system switched off until it has reached room temperature.
- If you connect other parts of the system, beware ground loops.
- If your Dap Audio device fails to work properly, discontinue use immediately. Pack the unit securely (preferably in the original packing material) and return it to your Dap Audio dealer for service.
- In system setup, the amplifier's output power must be 50%-100% higher than the loaded loudspeakers rated power.
- In typical use, please set the volume to 0dB position.
- Make sure that the amplifier is turned down, before turning the power on or off. In this way you can avoid supersonic frequencies, which could damage your speakers.
- Make sure that the available voltage is not higher than stated on the rear panel.
- Make sure that the power cord is never crimped or damaged. Check the device and the power cord from time to time.
- Make sure that the signals coming into the mixer are balanced, otherwise hum could be created.
- Make sure you do not use the wrong kind of cables or defective cables.
- Make sure you use DI boxes to balance unbalanced signals; All incoming signals should be clear
- Never let the power cord come into contact with other cables! Handle the power cord and all connections with the mains with particular caution!
- Never remove warning or informative labels from the unit.
- Never use anything to cover the ground contact.
- Only use device indoors, avoid contact with water or other liquids.
- Please read this manual carefully and keep it for future reference.
- Please turn off the power switch, when replacing the power cord, signal cable or selecting the input mode switch.
- Prevent distortion! Make sure that all components connected to the device have sufficient power ratings. Otherwise, distortion will be generated because the components are operated at their limits.
- Sometimes, when you want to send one signal to more than one amplifier, you should use a signal distributor.

- The best way to avoid ground loops is connecting the electrical system ground to one central point ("star" system). In this case the mixer can act as a central point.
- This device falls under protection class I. Therefore it is essential to connect the yellow/green conductor to earth.
- The user is responsible for correct positioning and operating of this product. The manufacturer will not accept liability for damages caused by the misuse or incorrect installation of this device.
- Repairs, servicing and electric connection must be carried out by a qualified technician.
- WARRANTY: Till one year after date of purchase.

Operating Determinations

This system is not designed for permanent operation. Consistent operation breaks will ensure that the system will serve you for a long time without defects.

If this system is operated in any other way than the one described in this manual, the product may suffer damages and the warranty becomes void.

Any other operation may lead to dangers like short-circuit, burns, electric shock, etc.

You endanger your own safety and the safety of others!

Improper installation can cause serious damage to people





Return Procedure



Returned merchandise must be sent prepaid and in the original packing, call tags will not be issued. Package must be clearly labeled with a Return Authorization Number (RMA number). Products returned without an RMA number will be refused. Highlite will not accept the returned goods or any responsibility. Call Highlite 0031-455667723 or mail offersales@highlite.nl and request an RMA prior to shipping the fixture. Be prepared to provide the model number, serial number and a brief description of the cause for the return. Be sure to properly pack fixture, any shipping damage resulting from inadequate packaging is the customer's responsibility. Highlite reserves the right to use its own discretion to repair or replace product(s). As a suggestion, proper UPS packing or double-boxing is always a safe method to use.

Note: If you are given an RMA number, please include the following information on a piece of paper inside the box:

- 01) Your name
- 02) Your address
- 03) Your phone number
- 04) A brief description of the symptoms

Claims

The client has the obligation to check the delivered goods immediately upon delivery for any shortcomings and/or visible defects, or perform this check after our announcement that the goods are at their disposal. Damage incurred in shipping is the responsibility of the shipper; therefore the damage must be reported to the carrier upon receipt of merchandise.

It is the customer's responsibility to notify and submit claims with the shipper in the event that a fixture is damaged due to shipping. Transportation damage has to be reported to us within one day after receipt of the delivery.

Any return shipment has to be made post-paid at all times. Return shipments must be accompanied with a letter defining the reason for return shipment. Non-prepaid return shipments will be refused, unless otherwise agreed in writing.

Complaints against us must be made known in writing or by fax within 10 working days after receipt of the invoice. After this period complaints will not be handled anymore.

Complaints will only then be considered if the client has so far complied with all parts of the agreement, regardless of the agreement of which the obligation is resulting.

Description of the device

Features

The COM-ART is a PLL UHF wireless audio set. The set consists of one transmitter and one receiver. The smart and lightweight design enables you to connect the receiver directly to any amplifier or active speaker. Both the transmitter and receiver can be powered with an AA battery or a USB power supply. The device operates properly within the range of 50 meters, in an ideal situation. In order to use the COM-ART for stereo purposes, you will need to purchase 2 sets. The frequency range 606-630 MHz is divided into 16 frequency presets.

COM-AT (Transmitter)

- Channel: Multi-channel, up to 16 frequency presets per each frequency band
- Frequency band: UHF 606-630 MHz, dependent on applicable country regulations
- Frequency response: 30 Hz - 17 kHz (± 3 dB)
- Oscillation mode: PLL UHF SYNTHESIZED
- Range: <50 m
- Frequency stability: $\pm 0.005\%$ (-10 ~ 50°C)
- T.H.D.: 1 kHz <0.3%
- Modulation mode: FM (F3E)
- Signal to noise: >98 dB
- Dynamic range: >100 dB
- RF output power: 10 mW
- Max. balance input/deviation: Max. 8 dBu/ ± 50 kHz
- Power requirements: AA (LR6) 1,5V
- Power supply: 5V DC (500 mA)
- Dimensions: 114 x 22 x 23 mm (LxWxH)
- Weight: 0,02 kg

COM-AR (Receiver)

- Channel: Multi-channel, up to 16 frequency presets per each frequency band
- Frequency band: UHF 606-630 MHz, dependent on applicable country regulations
- Receiver type: PLL UHF SYNTHESIZED
- Range: <50 m
- Frequency response: 30 Hz – 17 kHz (± 3 dB)
- Frequency stability: $\pm 0.005\%$ (-10 ~ 50°C)
- T.H.D.: 1 kHz <0.3%
- Modulation mode: FM (F3E)
- Signal to noise: >98 dB
- Dynamic range: >100 dB
- RF sensitivity: -100 dBm/12 dB SINAD
- Max. balance output/deviation: Max. 8 dBu/ ± 50 kHz
- Power requirements: AA (LR6) 1,5V
- Power supply: 5V DC (500 mA)
- Dimensions: 101 x 22 x 23 mm (LxWxH)
- Weight: 0,02 kg

Note: the maximum range of 50 m can only be achieved in an ideal situation, for the best position see page 9 for more information.

Frontside

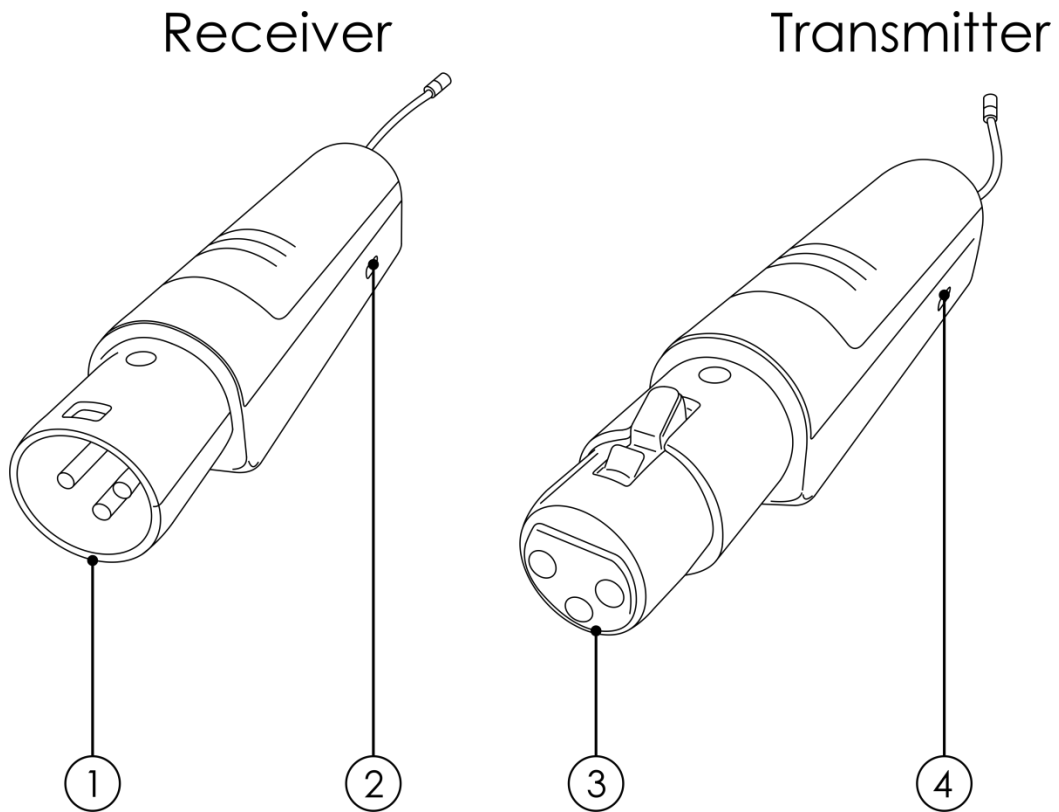

Fig. 01

- ① COM-AR (receiver) 3-pin XLR IN
- ② 5V Mini USB power connector IN
- ③ COM-AT (transmitter) 3-pin XLR OUT
- ④ 5V Mini USB power connector IN

Backside

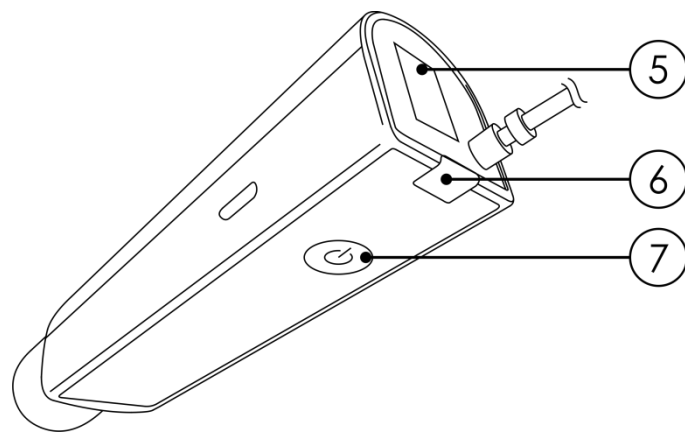

Fig. 02

- ⑤ LED display
- ⑥ Battery indicator
- ⑦ SET button

Installation

Remove all packing materials from the COM-ART. Check if all foam and plastic padding is removed. Connect all cables.

Do not supply power before the whole system is set up and connected properly.

Always disconnect from electric mains power supply before cleaning or servicing.

Damages caused by non-observance are not subject to warranty.

Power Supply

The COM-ART can be powered with an AA battery, or with the included USB cable connected to an USB adapter (5V, 500mA).

Note: The USB power inlet is to power the device not to charge the battery. Please don't apply USB power when a battery is inserted. It can cause dangerous situations and will damage both battery and the device. Any warranty will be expired.

Replace the Battery

- 01) Press and pull the battery cover to open the battery housing.
- 02) Insert an AA battery (use good disposable batteries or good rechargeable batteries).
- 03) Replace the battery cover.

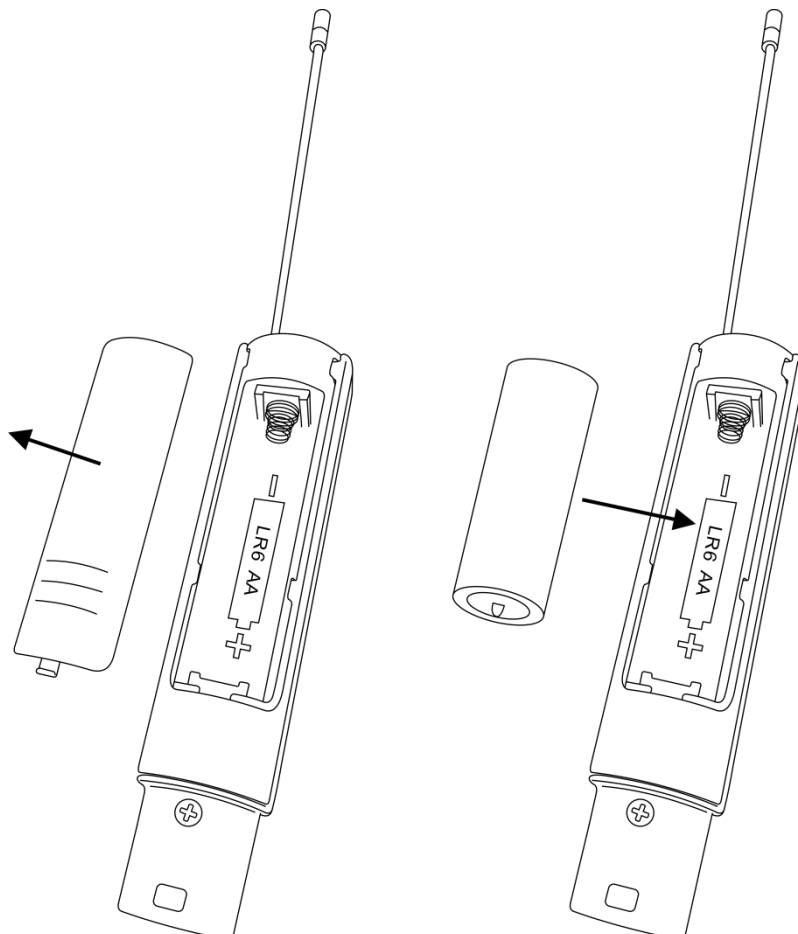

Fig. 03

Set Up and Operation

Location

For best operation, the COM-AT (transmitter) and the COM-AR (receiver) should be:

- Located above the ground, as high as possible,
- Positioned away from walls or metal surfaces, to minimize reflections,
- The receiver antenna should be kept away from noise sources such as other digital equipment, microwave ovens or other large metal objects. The device works best when the receivers are located within the line of sight of the transmitter.

Connection

- 01) Connect the COM-AT (transmitter) to your mixer's main XLR output.
- 02) Connect the COM-AR (receiver) to an amplifier/active speaker.

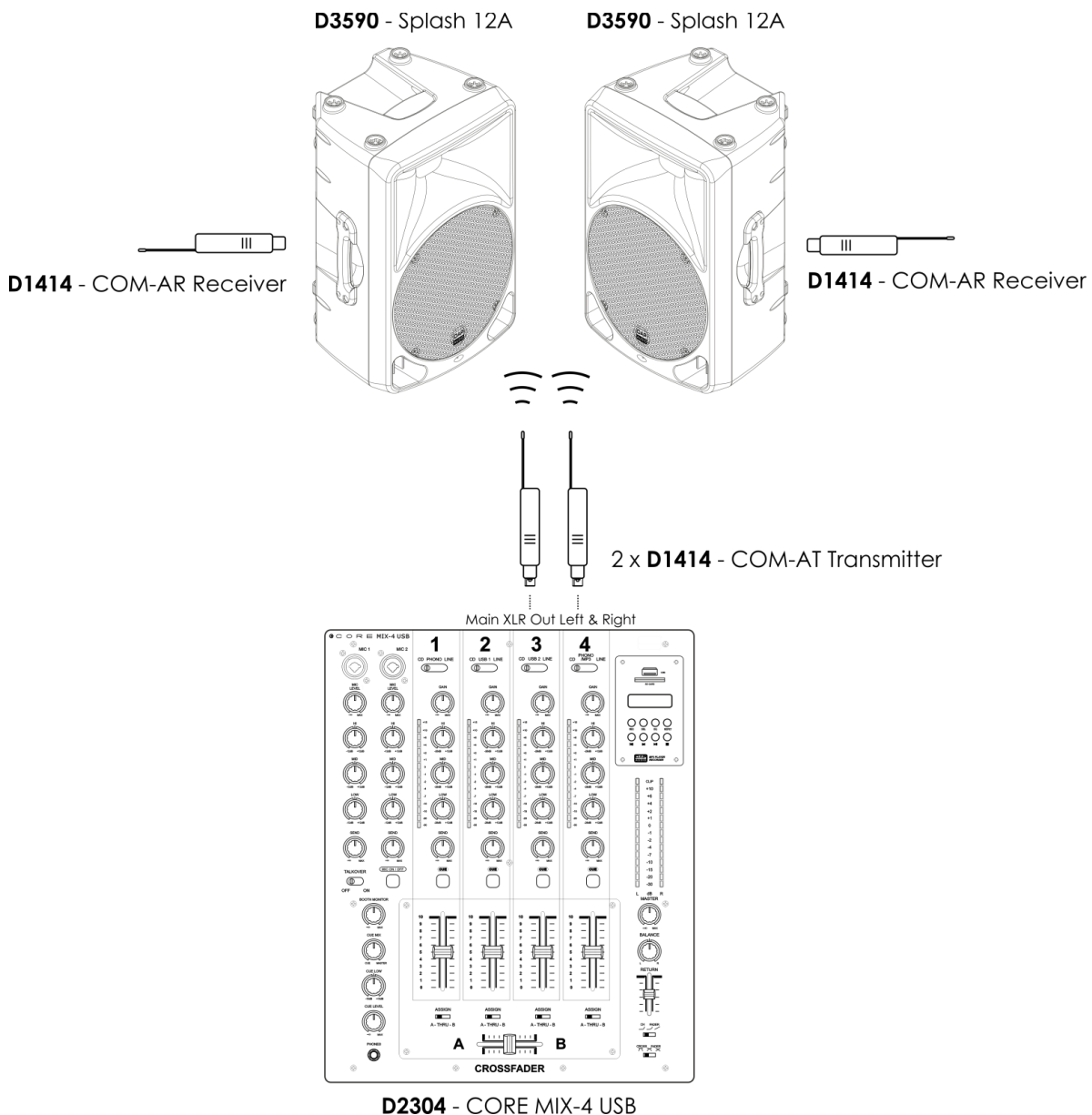

Fig. 04

Note: In order to produce stereo sound, it is necessary to purchase **2 sets** of **D1414** (see fig. 04).

Power On/Off

- 01) The device will switch on automatically, upon receiving power. The display will show the currently selected frequency preset and will blink 3 times. When no button is pressed for 5 seconds, the display will turn off.
- 02) In order to switch the device off, press and hold down the **SET** button (**07**) for 2 seconds.
- 03) In order to switch the device on, again press and hold down the **SET** button (**07**) for 2 seconds.

Battery Indicator

- 01) When the device is connected to the appropriate AC power supply or is powered with an AA battery, the **battery indicator (06)** will blink in green.
- 02) When the device is receiving an RF signal, the **battery indicator (06)** will light in green.
- 03) If the capacity of the battery is too low, the **battery indicator (06)** will light in red. Replace the battery immediately, see page 8 for more information.

Operation

- 01) Repeatedly press the **SET** button (**07**) on both the transmitter and the receiver to select the corresponding frequency preset. The adjustment range is between 0-9 and A-F.
- 02) The settings will be stored, even after switching the device off.



- 03) It is possible to send signals to multiple COM-AR (receivers), as long as they are all set to the same frequency preset, as the COM-AT (transmitter). No further pairing is required.

Frequency Range

606-630 MHz	
Preset	Frequency (MHz)
0	606,125
1	607,625
2	609,050
3	610,425
4	610,900
5	613,525
6	615,100
7	616,475
8	618,000
9	620,075
A	622,975
B	623,975
C	625,050
D	626,975
E	628,425
F	629,975

It is possible that the COM-ART will not function properly within certain frequencies. It may be caused by the presence of other digital equipment, producing interference.



Try testing all the 16 frequency presets available on the COM-ART, until you find the one which functions properly.



Connection Cables

Take care of your cables by always holding them by the connectors and avoiding knots and twists when coiling them: This gives the advantage of increasing their lifespan and reliability. Periodically check your cables. A great number of problems (faulty contacts, ground hum, discharges, etc.) are caused entirely by using unsuitable or faulty cables.

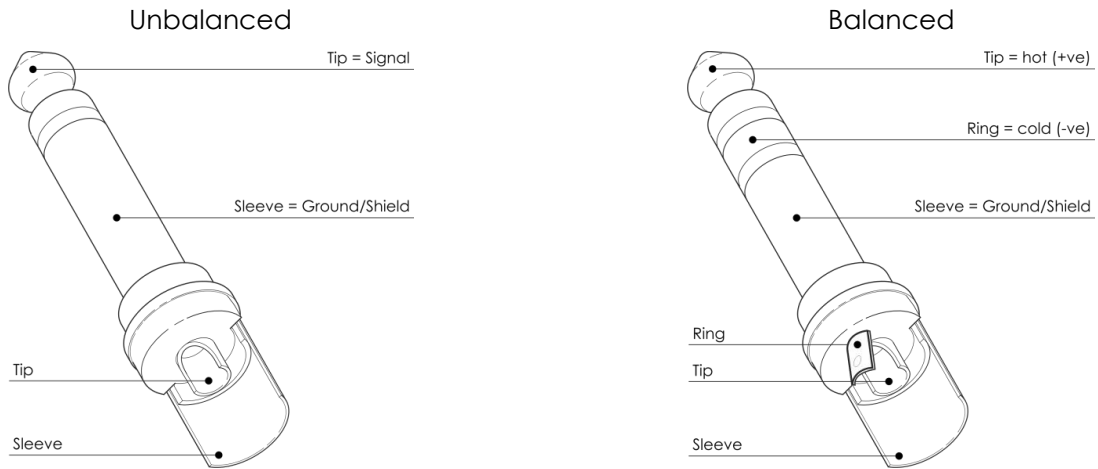

For these applications the unit provides 1/4" TRS and XLR connectors to easily interface with most professional audio devices. Follow the configuration examples below for your particular connection.

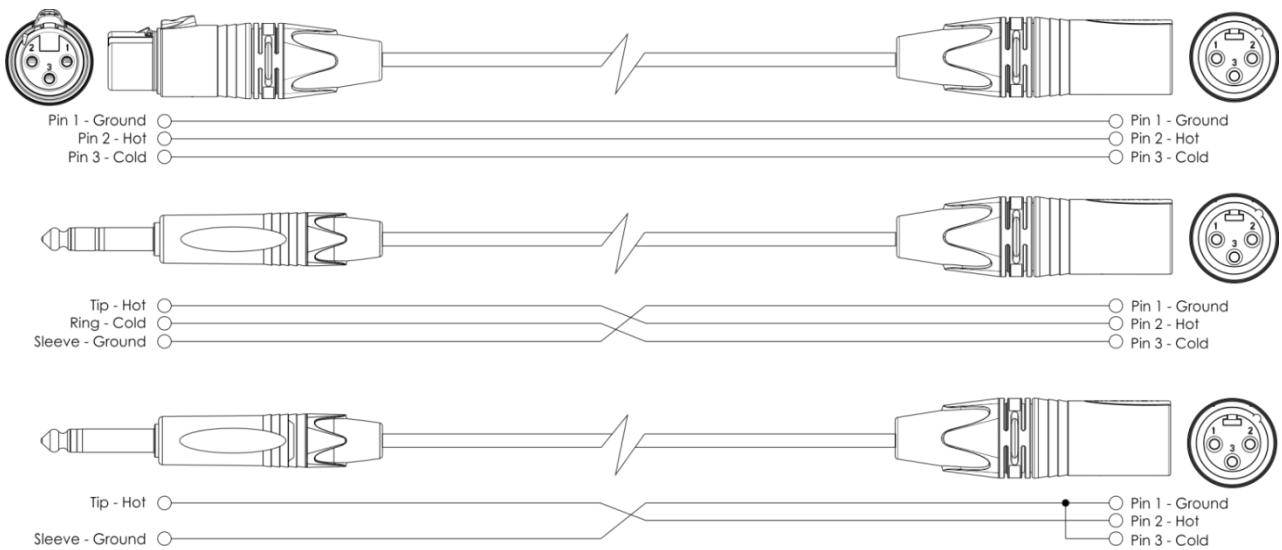

Maintenance

The COM-ART requires almost no maintenance. However, you should keep the unit clean. Disconnect the mains power supply and wipe with a damp cloth. Do not immerse in liquid. Wipe clean with a soft cloth. Do not use alcohol or solvents.

Keep connections clean. Disconnect electric power, and then wipe the connections with a damp cloth. Make sure connections are thoroughly dry before linking equipment or supplying electric power.

Product Specifications

COM-AT (Transmitter)

Channel:	Multi-channel, up to 16 frequency presets per each frequency band
Frequency band:	UHF 606-630 MHz, dependent on applicable country regulations
Frequency response:	30 Hz - 17 kHz (± 3 dB)
Oscillation mode:	PLL UHF SYNTHESIZED
Range:	<50 m
Frequency stability:	$\pm 0.005\%$ (-10 ~ 50°C)
T.H.D.:	1 kHz <0.3%
Modulation mode:	FM (F3E)
Signal to noise:	>98 dB
Dynamic range:	>100 dB
RF output power:	10 mW
Max. balance input/deviation:	Max. 8 dBu/ ± 50 kHz
Power requirements:	AA (LR6) 1,5V
Power supply:	5V DC (500 mA)
Dimensions:	114 x 22 x 23 mm (LxWxH)
Weight:	0,02 kg

COM-AR (Receiver)

Channel:	Multi-channel, up to 16 frequency presets per each frequency band
Frequency band:	UHF 606-630 MHz, dependent on applicable country regulations
Receiver type:	PLL UHF SYNTHESIZED
Range:	<50 m
Frequency response:	30 Hz - 17 kHz (± 3 dB)
Frequency stability:	$\pm 0.005\%$ (-10 ~ 50°C)
T.H.D.:	1 kHz <0.3%
Modulation mode:	FM (F3E)
Signal to noise:	>98 dB
Dynamic range:	>100 dB
RF sensitivity:	-100 dBm/12 dB SINAD
Max. balance output/deviation:	Max. 8 dBu/ ± 50 kHz
Power requirements:	AA (LR6) 1,5V
Power supply:	5V DC (500 mA)
Dimensions:	101 x 22 x 23 mm (LxWxH)
Weight:	0,02 kg

Design and product specifications are subject to change without prior notice.



Website: www.Dap-audio.info
 Email: service@highlite.nl

Dimensions

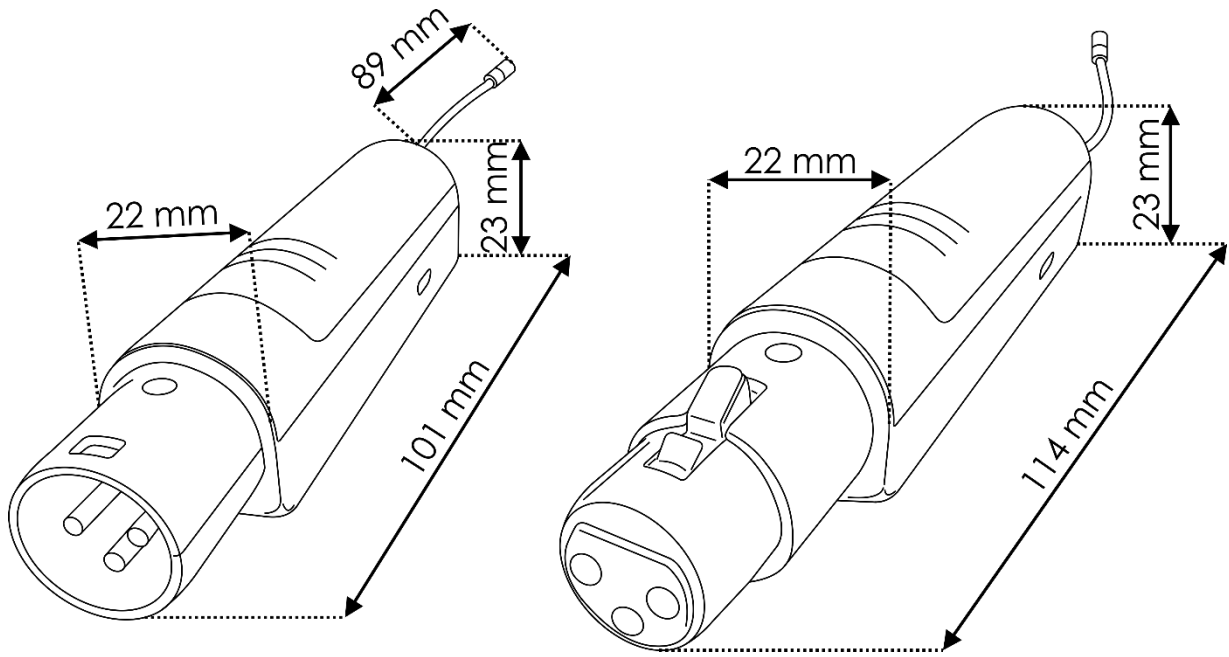



©2018 DAP Audio