

DREAM YUGA

OWNER'S MANUAL

© Honda Motor Co., Ltd. 2016

IMPORTANT INFORMATION

- **OPERATOR AND PASSENGER**

This vehicle is designed to carry the rider and one passenger. Never exceed the maximum weight capacity.

- **ON-ROAD USE**

This vehicle is designed to be used only on the road.

- **READ THIS OWNER'S MANUAL CAREFULLY**

Pay special attention to the safety messages that appear throughout the manual.

These messages are fully explained in the **"A Few Words About Safety"** section which appears before the contents page.

This manual should be considered as a permanent part of the vehicle and should remain with the vehicle when resold.

DREAM YUGA OWNER'S MANUAL

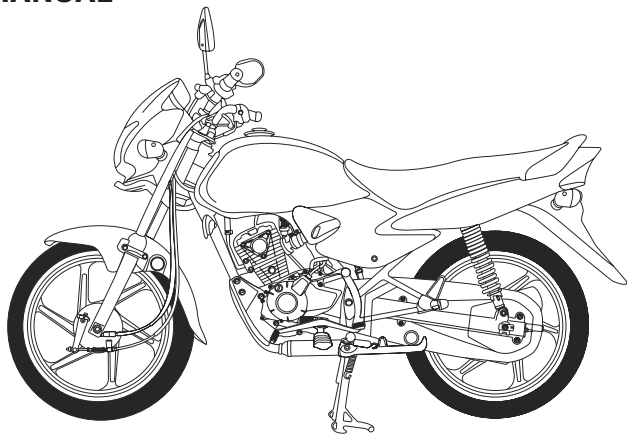

All information in this publication is based on the latest production information available at the time of approval for printing. Honda Motor Co., Ltd. reserves the right to make changes at any time without notice and without incurring any obligation.

No part of this publication may be reproduced without written permission.

WELCOME

The vehicle presents you a challenge to master the machine, a challenge to adventure. You ride through the wind, linked to the road by a vehicle that responds to your commands as no other does. Unlike an automobile, there is no metal cage around you. Like an aeroplane, a pre-ride inspection and regular maintenance are essential to your safety. Your reward is freedom.

To meet the challenges safely, and to enjoy the adventure fully, you should become thoroughly familiar with this owner's manual BEFORE YOU RIDE THE VEHICLE.

As you read this manual, you will find information that is preceded by a symbol. This information is intended to help you avoid damage to your vehicle, other property, or the environment.

When service is required, remember that your Honda dealer knows your vehicle. If you have the required mechanical "know-how" and tools, your dealer can supply you an official Honda shop manual on paid basis to help you perform many maintenance and repair tasks.

Accessories shown in the illustration are not part of the standard equipment.

For any query or assistance, please call Customer Care No.:

1800 103 3434 (Toll free)

Pleasant riding, and thank you for choosing a Honda!

- The specifications may vary with each locale.

A FEW WORDS ABOUT SAFETY

Your safety, and the safety of others, is very important. Operating this vehicle safely is an important responsibility.

To help you make informed decisions about safety, we have provided operating procedures and other information on labels in this manual. This information alerts you to potential hazards that could hurt you or others.

Of course, it is not practical or possible to warn you about all hazards associated with operating or maintaining a vehicle. You must use your own good judgement.

You will find important safety information in a variety of forms, including :

- **Safety labels** - on the vehicle.
- **Safety messages** - preceded by a safety alert symbol  and one of three signal words: **DANGER**, **WARNING**, or **CAUTION**.

These signal words mean:



You **WILL** be **KILLED** or **SERIOUSLY HURT** if you don't follow instructions.



You **CAN** be **KILLED** or **SERIOUSLY HURT** if you don't follow instructions.



You **CAN** be **HURT** if you don't follow instructions.

- **Safety Heading** - such as Important Safety Reminders or Important Safety Precautions.
- **Safety Section** – such as vehicle Safety.
- **Instructions** – how to use this vehicle correctly and safely.

This entire manual is filled with important safety information—please read it carefully.

CONTENTS

Page

1	VEHICLE SAFETY
1	Important Safety Information
2	Protective Apparel
3	Load Limits and Guidelines
7	PARTS LOCATION
10	Instrument and Indicators
12	MAJOR COMPONENTS (Important Information to operate this vehicle)
12	Suspension
13	Brakes
16	Clutch
17	Fuel
19	Engine Oil
21	Tyres
24	ESSENTIAL INDIVIDUAL COMPONENTS
24	Ignition Switch

Page

25	Right Handlebar Controls
25	Left Handlebar Controls
27	FEATURES (Not required for operation)
27	Steering Lock
27	Right Side Cover
28	Left Side Cover
28	Storage Compartment
29	Headlight Aim Vertical Adjustment
29	OPERATION
29	Pre-ride Inspection
30	Starting the Engine
32	Running-in
32	Riding
34	Braking
35	Parking
35	Anti-theft Tips

Page

36 MAINTENANCE

36	The Importance of Maintenance
36	Maintenance Safety
37	Safety Precautions
38	Maintenance Schedule
41	Tool Kit
41	Serial Numbers
42	Color Code
43	Engine Oil
45	Crankcase Breather
46	Spark Plug
47	Valve Clearance
49	Idle Speed
50	Throttle Operation
50	Air Cleaner
51	Drive Chain
56	Front and Rear Suspension Inspection

Page

57	Side Stand
57	Wheel Removal
61	Battery
63	Fuse Replacement
65	Brake Light Switch Adjustment
66	Bulb Replacement
69	CLEANING
71	STORAGE GUIDE
71	Storage
73	SPECIFICATIONS
76	CATALYTIC CONVERTER

VEHICLE SAFETY

IMPORTANT SAFETY INFORMATION

Your vehicle can provide many years of service and pleasure if you take responsibility for your own safety and understand the challenges that you can meet on the road.

There is much that you can do to protect yourself when you ride. You'll find many helpful recommendations throughout this manual. Following are few that we consider most important.

Always Wear a Helmet

It's a proven fact: helmets significantly reduce the number and severity of head injuries. So always wear an approved helmet and make sure your passenger does the same. We also recommend that you wear eye protection, sturdy boots, gloves, and other protective gear (page 2).

Make Yourself Easy to be Visible

Some drivers do not see vehicles because they are not looking for them. To make yourself more visible, wear bright reflective clothing, position yourself so other drivers can see you, signal before turning or changing lanes, and use your horn when it will help others notice you.

Ride Within Your Limits

Pushing the limits is another major cause of vehicle accidents. Never ride beyond your personal abilities or faster than conditions warrant. Remember that alcohol, drugs, fatigue and inattention can significantly reduce your ability to make good judgements and ride safely.

Keep Your Vehicle in Safe Condition

For safe riding, it's important to inspect your vehicle before every ride and perform all recommended maintenance. Never exceed load limits, and only use accessories that have been approved by Honda for this vehicle. See page 6 for more details.

Don't Drink and Ride

Don't mix Alcohol and riding. Even one drink can reduce your ability to respond to changing conditions, and your reaction time gets worse with every additional drink. So don't drink and ride, and don't let your friends drink and ride either.

PROTECTIVE APPAREL

For your safety, we strongly recommend that you always wear an approved helmet, eye protection, boots, gloves, long pants, and a long-sleeved shirt or jacket whenever you ride. Although complete protection is not possible, wearing proper gear can reduce the chance of injury when you ride.

Following are suggestions to help you choose proper gear.

WARNING

Not wearing a helmet increases the chance of serious injury or death in a crash.

Be sure you and your passenger always wear a helmet, eye protection and other protective apparel when you ride.

Helmets and Eye Protection

Your helmet is your most important piece of riding gear because it offers the best protection against head injuries. A helmet should fit your head comfortably and securely. A bright-coloured helmet can make you more noticeable in traffic, as can reflective strips.

An open-face helmet offers some protection, but a full-face helmet offers more. Always wear a face shield or goggles to protect your eyes and help your vision.

Additional Riding Gear

In addition to a helmet and eye protection, we also recommend:

- Sturdy boots with non-slip soles to help protect your feet and ankles.
- Leather gloves to keep your hands warm and help prevent blisters, cuts, burns and bruises.

- A vehicle riding suit or jacket for comfort as well as protection. Bright coloured and reflective clothing can help make you more noticeable in traffic. Be sure to avoid loose clothes that could get caught on any part of your vehicle.

LOAD LIMITS AND GUIDELINES

Your vehicle has been designed to carry you and one passenger. When you carry a passenger, you may feel some difference during acceleration and braking. But so long as you keep your vehicle well- maintained, with good tyres and brakes, you can safely carry loads within the given limits and guidelines.

However, exceeding the weight limit or carrying an unbalanced load can seriously affect your vehicle's handling, braking and stability. Non-Honda accessories, improper modifications, and poor maintenance can also reduce your safety margin.

The following pages give more specific information on loading, accessories and modifications.

Loading

How much weight you put on your vehicle, and how you load it, are important to your safety. Anytime you ride with a passenger or cargo you should be aware of the following information.

WARNING

Overloading or improper loading can cause a crash and you can be seriously hurt or killed.

Follow all load limits and other loading guidelines in this manual.

Load Limits

Following are the load limits for your vehicle:

Maximum weight capacity:

170 kg (375 lbs)

Includes the weight of the rider, passenger, all cargo and all accessories

LOADING GUIDELINES

Your vehicle is primarily intended for transporting you and a passenger. You may wish to secure a jacket or other small items to the seat when you are not riding with a passenger. If you wish to carry more cargo, check with your Honda dealer for advice, and be sure to read the information regarding accessories on page 6.

Improperly loading your vehicle can affect its stability and handling. Even if your vehicle is properly loaded, you should ride at reduced speeds whenever carrying cargo.

Follow these guidelines whenever you carry a passenger or cargo:

- Check that both tyres are properly inflated.
- To prevent loose items from creating a hazard, make sure that all cargo is securely tied down before you ride away.
- Place cargo weight as close to the center of the vehicle as possible.
- Balance cargo weight evenly on both sides.
- Do not attach large or heavy items (such as a sleeping bag or tent) to the handlebars, forks or fender.

Accessories and Modifications

Modifying your vehicle or using non-Honda accessories can make your vehicle unsafe. Before you consider making any modifications or adding an accessory, be sure to read the following information.

WARNING

Improper accessories or modifications can cause a crash in which you can be seriously hurt or killed.

Follow all instructions in this owner's manual regarding accessories and modifications.

Accessories

We strongly recommend that you use only Honda Genuine Accessories that have been specifically designed and tested for your vehicle. Because Honda cannot test all other accessories, you must be personally responsible for proper selection, installation and use of non-Honda accessories. Check with your dealer for assistance and always follow these guidelines:

- Make sure the accessory does not obscure any lights, reduce ground clearance and banking angle, limit suspension travel or steering travel, alter your riding position or interfere with operating any controls.
- Be sure not to use any non-genuine electrical equipment or equipment having capacity exceeding vehicle's electrical system capacity (page 75). A blown fuse can cause a loss of lights or engine power.

- Do not pull a trailer or sidecar with your vehicle. This vehicle is not designed for these attachments, and their use can seriously impair your vehicle's handling.

MODIFICATIONS

We strongly advise you not to remove any original equipment or modify your vehicle in any way that would change its design or operation. Such changes could seriously impair your vehicle's handling, stability and braking, making it unsafe to ride.

Removing or modifying your lights, mufflers, emission control system or other equipment can also make your vehicle illegal.

PARTS LOCATION /पुर्जों की स्थिति

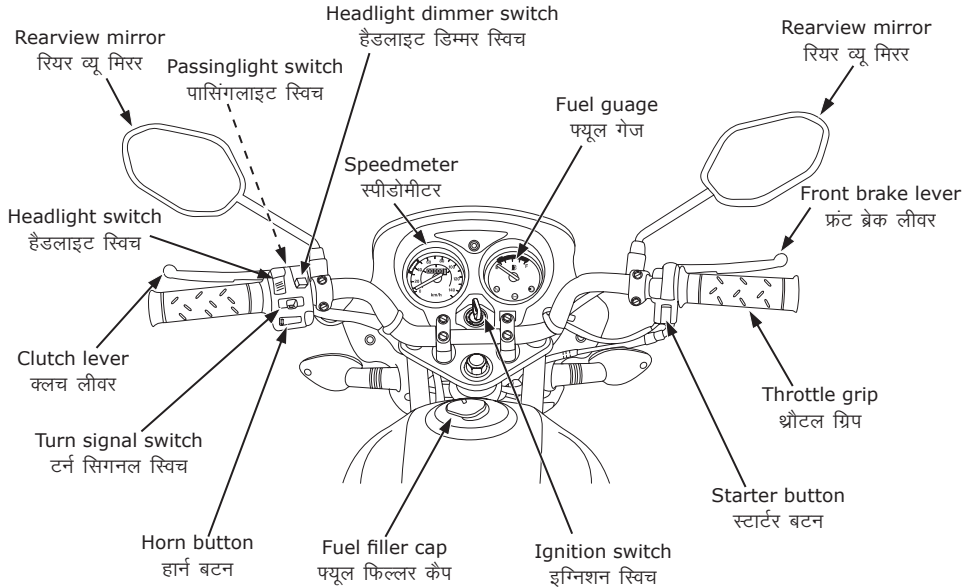

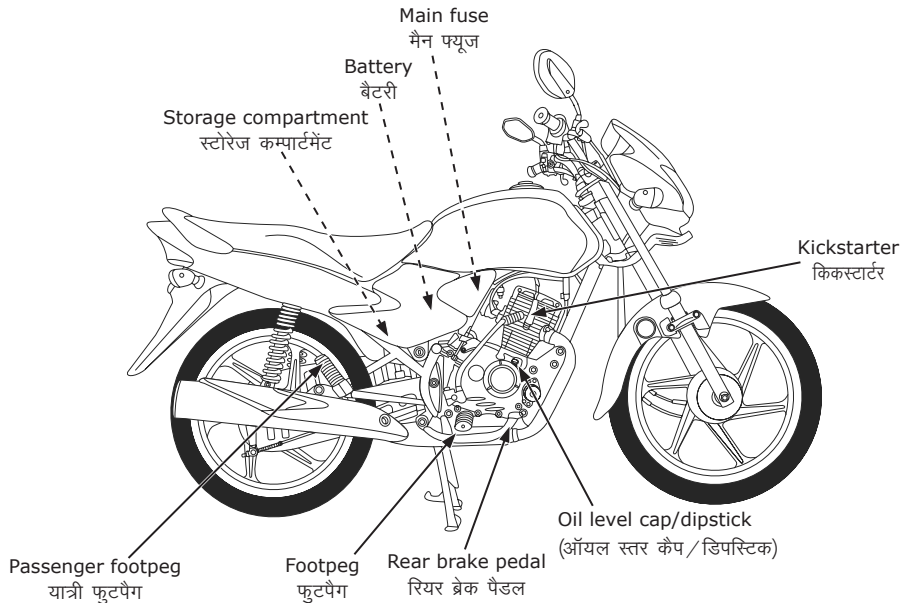

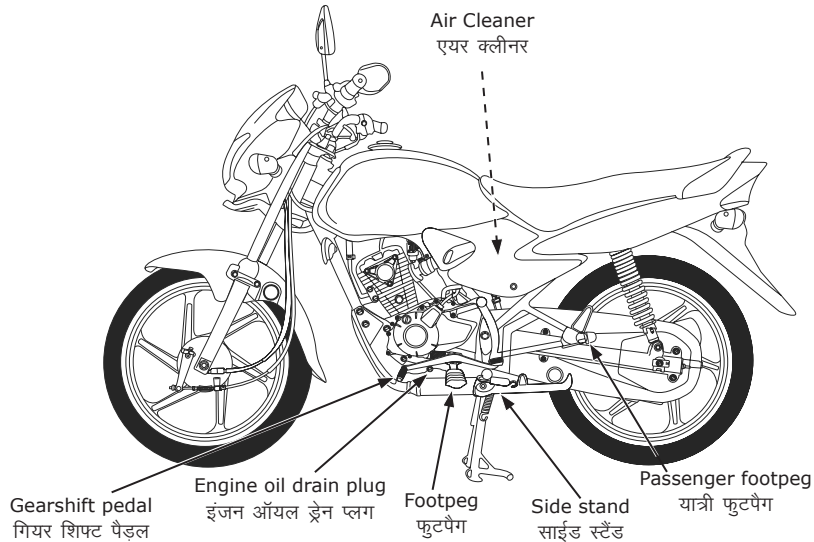

INSTRUMENT AND INDICATORS

The indicators are contained in the instrument panel. Their functions are described in the tables on the following pages.

- (1) Speedometer (स्पीडोमीटर)
- (2) Gear range (गियर रेंज)
- (3) Odometer (ऑडोमीटर)
- (4) Fuel meter (फ्यूल मीटर)
- (5) High beam indicator (हाई बीम इंडिकेटर)
- (6) Turn signal indicator (टर्न सिगनल इंडिकेटर)
- (7) Neutral indicator (न्यूट्रल इंडिकेटर)

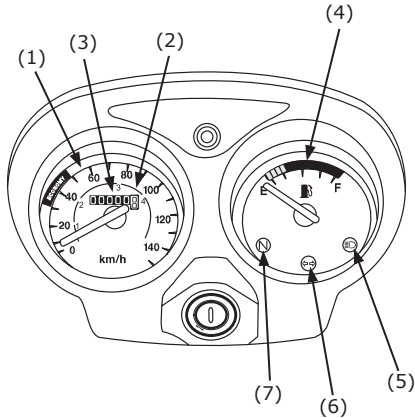

(Ref.No.) Description	Function
1. Speedometer	Shows riding speed.
2. Gear range	Shows proper speed range for each gear.
3. Odometer	Shows accumulated mileage.
4. Fuel meter	Shows approximate fuel function available (page 12).
5. High beam indicator (blue)	Indicate when the headlight is glowing on high beam.
6. Turn signal indicator (orange)	Flashes when any of the turn signal operates.
7. Neutral indicator (green)	Indicate when the transmission is in neutral.

FUEL METER

When the gauge needle enters the red band (2), it shows the less fuel in the tank. Turn the fuel valve to the RES position and you should refill the tank as soon as possible. The amount of fuel left in the tank with the vehicle set upright when the needle enters the red band is approximately.

1.5 L (0.39 US gal, 0.32 Imp gal)

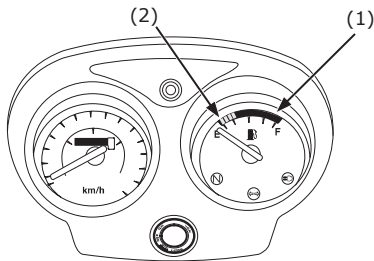

- (1) Fuel meter (फ्यूल मीटर)
(2) Red band (रैड बैंड)

MAJOR COMPONENTS

(Important Information to operate this vehicle)

SUSPENSION

The shock absorber (1) has 5 adjustment positions for different load or riding conditions.

Use a pin spanner (2) to adjust the rear shock. Turning the spring preload adjuster (3) counterclockwise makes the shock absorber firm, and turning clockwise makes it soft.

Always adjust the shock absorber position in sequence (1-2-3-4-5 or 5-4-3-2-1).

Attempting to adjust directly from 5 to 1 may damage the shock absorber.

Position 5 increases spring preload for a stiffer rear suspension, and can be used when the motorcycle is heavily loaded.

NOTICE

For rear shock absorber adjustment visit to your nearest Honda dealer.

Standard position: 2

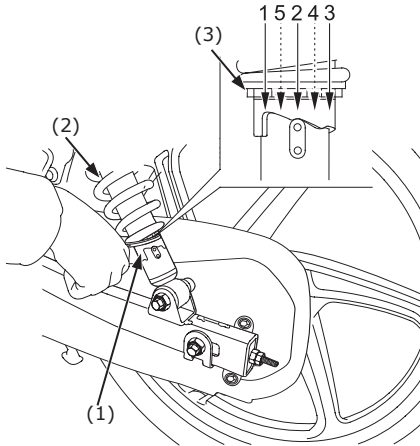

- (1) Shock absorber (शॉक एबजार्बर)
- (2) Pin spanner (पिन स्पैन्डर)
- (3) Spring preload adjuster (सिप्रिंग प्री-लॉड एडजस्टर)

BRAKES

Front Brake

Brakes are items of personal safety and should always be maintained in proper adjustment.

The distance the front brake lever or rear brake pedal moves before the brake starts to engage is called freeplay.

Measured at the tip of the front brake lever (1), freeplay should be maintained at:

10-20 mm (0.4-0.8 in)

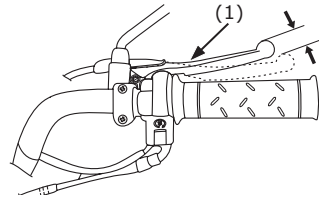

- (1) Front brake lever (फ्रंट ब्रेक लीवर)

Adjustment:

1. Front brake adjustment should be made using the front brake adjustment nut (2) at the front wheel.
2. Adjust the brake lever free play with the front brake-adjusting nut. Turning the nut clockwise will decrease freeplay and turning the nut counterclockwise will increase freeplay.

Make sure the cut-out on the adjusting nut is seated on the brake arm pin (3) after making final freeplay adjustment.

Apply the brake several times and check for free wheel rotation after the brake lever is released.

If proper adjustment cannot be obtained by this method, see your Honda dealer.

Other Checks:

Check the brake cable for kinks or signs of wear that could cause sticking or failure.

Make sure the brake arm, spring and fasteners are in good condition.

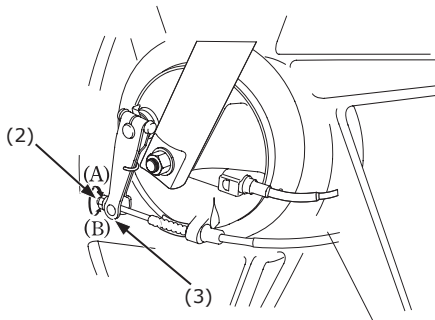

(2) Front brake adjustment nut
(फ्रंट ब्रेक एडजस्टमेंट नट)

(3) Brake arm pin (ब्रेक आर्म पिन)

(A) Decrease freeplay (फ्री प्ले घटाएँ)

(B) Increase freeplay (फ्री प्ले बढ़ाएँ)

Rear Brake

Adjustment:

1. Place the vehicle on its center stand.
2. Measure the distance of rear brake pedal (1) moves before the brake starts to take hold.

Freeplay should be:

20-30 mm (0.8-1.2 in)

3. If adjustment is necessary, turn the adjusting nut (2).

Make sure the cut-out on the adjusting nut is seated on the brake arm pin (3) after making final free play adjustment.

4. Apply the brake several times and check for free wheel rotation after the brake pedal is released.

If proper adjustment cannot be obtained by this method, see your Honda dealer.

Other Checks:

Make sure the brake rod, brake arm, spring and fasteners are in good condition.

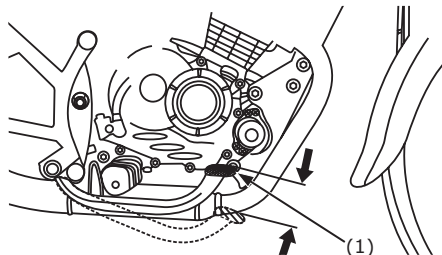

(1) Rear brake pedal (रियर ब्रेक पैडल)

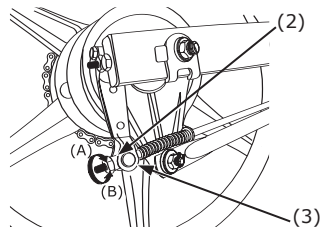

(2) Adjusting nut (एडजस्टिंग नट)

(3) Brake arm pin (ब्रेक आर्म पिन)

(A) Decrease freeplay (फ्री प्ले घटाएँ)

(B) Increase freeplay (फ्री प्ले बढ़ाएँ)

Clutch

Clutch adjustment may be required if the vehicle stalls when shifting into gear or tends to creep; or if the clutch slips, causing acceleration to lag behind engine speed.

Normal clutch lever freeplay is:
10-20 mm (0.4-0.8 in)

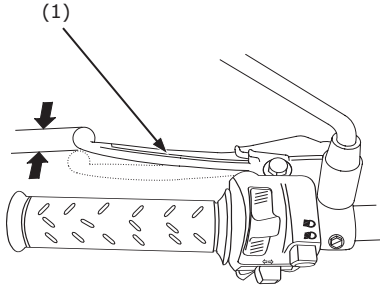

(1) Clutch lever (क्लच लीवर)

1. Loosen the lock nut (2) at the lower end of the cable. Turn the adjusting nut (3) to obtain the specified freeplay. Tighten the lock nut and check the adjustment.
2. Start the engine, pull in the clutch lever and shift into gear. Make sure the engine does not stall and the vehicle does not creep. Gradually release the clutch lever and open the throttle. The vehicle should begin to move smoothly and accelerate gradually.

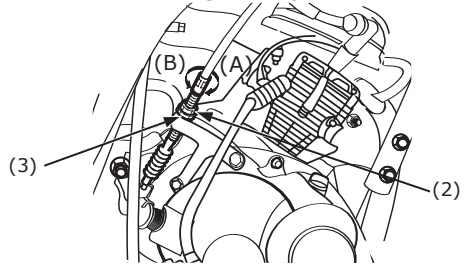

(2) Lock nut (लॉक नट)

(3) Adjusting nut (एडजस्टिंग नट)

(A) Decrease freeplay (फ्री प्ले घटाएँ)

(B) Increase freeplay (फ्री प्ले बढ़ाएँ)

If proper adjustment cannot be obtained or the clutch does not work correctly, see your Honda dealer.

Other Checks:

Check the clutch cable for kinks or signs of wear that could cause sticking or failure.

FUEL

Fuel knob

The three-way fuel knob (1) is on the left side below the fuel tank.

ON

With the fuel valve in the ON position, fuel will flow from the main fuel supply to the carburetor.

OFF

With the fuel knob in the OFF position, fuel cannot flow from the tank to the carburetor. Turn the knob to OFF position whenever the vehicle is not in use.

RES

With the fuel knob in the RES position, fuel will flow from the reserve fuel supply to the carburetor. Use the reserve fuel only when the main supply is gone. Refill the tank as soon as possible after switching to RES. The reserve fuel supply is:

1.5 L (0.39 US gal, 0.32 Imp gal)

Remember to check that the fuel knob is in ON position each time you refuel. If the knob is left in RES position, you may not notice when you run out of fuel with no reserve.

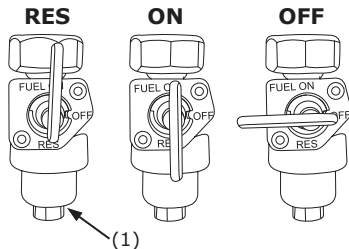

(1) Fuel knob (फ्यूल नॉब)

Fuel Tank

The fuel tank capacity including the reserve supply is:

8.0 L (2.11 US gal, 1.76 Imp gal)

To open the fuel fill cap (1), slide the fuel cap key shutter insert the ignition key (2) and turn it clockwise. The fuel fill cap will pop up and can be lifted off. Do not overfill the tank. There should be no fuel in the filler neck.

After refueling, to close the fuel fill cap, keep the mark of front side of fuel filler cap at front. Push the fuel fill cap into the filler neck until it snaps closed and gets locked. Remove the key.

⚠ WARNING

Petrol is highly flammable and explosive. You can be burned or seriously injured when handling fuel.

- Stop the engine and keep heat, sparks, and flame away.
- Refuel only outdoors.
- Wipe up spills immediately.

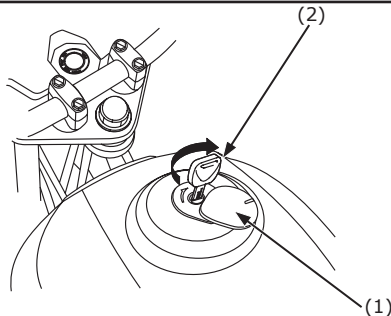

(1) Fuel fill cap (फ्यूल फिल कैप)

(2) Ignition key (इग्नीशन की)

Use unleaded petrol with a research octane number of 88 or higher. We recommend that you use unleaded petrol because it produces fewer engine and spark plug deposits and extends the life of exhaust system components.

NOTICE

If "spark knock" or "pinking" occurs at a steady engine speed under normal load, change brands of petrol. If the spark knock or pinking persists, consult your Honda dealer. Failure to do so is considered misuse, and damage caused by misuse is not covered by Honda's Limited Warranty.

Petrol Containing Alcohol

If you decide to use a petrol containing alcohol (gasohol), be sure it's octane rating is at least as high as that recommended by Honda.

WARNING

Adulterated fuel not to be used. It causes damage to the engine parts and considered as misuse, damage caused by misuse is not covered under Honda warranty.

- When certain types of petrol containing alcohol are used, problem such as hard starting, poor performance, etc. may occur.
- If you notice any undesirable operating symptoms while using a petrol that contains alcohol, try another station or switch to another brand of petrol.
- When a problem resulting from the use of petrol containing alcohol occurs, contact your Honda dealer.

ENGINE OIL

ENGINE OIL LEVEL CHECK

Check the engine oil level each day before riding the vehicle.

The level must be maintained between the upper (1) and lower (2) level marks on the oil level cap/dipstick (3).

1. Start the engine and let it idle for 3-5 minutes.
2. Stop the engine and put the vehicle on its center stand on level ground.
3. After 2-3 minutes, remove the oil filler cap/dipstick, wipe it clean, and reinsert the oil filler cap/dipstick without screwing it in. Remove the oil filler cap/dipstick. The oil level should be between the upper and lower level marks on the oil filler cap/dipstick.
4. If required, add the specified oil up to the upper level mark. Do not overfill.
5. Reinstall the oil filler cap/dipstick. Check for oil leaks.

NOTICE

Running the engine with insufficient oil pressure may cause serious engine damage.

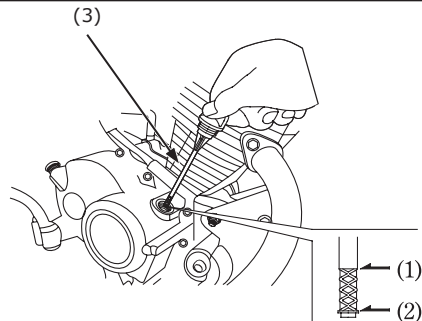

- (1) Upper level mark (ऊपरी स्तर चिन्ह)
- (2) Lower level mark (निचला स्तर चिन्ह)
- (3) Oil level cap/dipstick (ऑयल स्तर कैप/डिपस्टिक)

TYRES

To safely operate your vehicle, your tyres must be the proper type and size, in good condition with adequate tread, and correctly inflated for the load you are carrying. The following pages give more detailed information on how and when to check your air pressure, how to inspect your tyres for damage and what to do when your tyres need to be repaired or replaced.

WARNING

Using tyres that are excessively worn or improperly inflated can cause a crash in which you can be seriously hurt or killed.

Follow all instructions in the owner's manual regarding tyre inflation and maintenance.

Air Pressure

Keeping your tyres properly inflated provides the best combination of handling, tread life and riding comfort. Generally

under inflated tyres wear unevenly, adversely affect handling, and are more likely to fail from being overheated.

Over inflated tyres make your motorcycle ride harshly, are more prone to damage from road hazards, and wear unevenly.

We recommend that you visually check your tyres before every ride and use gauge to measure air pressure at least once a month or any time you think the air pressure might be low.

Always check air pressure when your tyres are "cold"- When the vehicle has been parked at least three-four hours. If you check air pressure when your tyres are "warm" - when the vehicle has been ridden for even a few miles- the reading will be higher than of the tyres were "cold". This is normal; so do not let air out of the tyres to match the recommended air pressures given below. If you do the tyres will be under inflated.

The recommended “cold” tyre pressures are:

kPa (kgf/cm ² , psi)		
Driver Only	Front	175 (1.75 , 25)
	Rear	225 (2.00 , 32)
Driver and One passenger	Front	175 (1.75 , 25)
	Rear	280 (2.80 , 40)



NOTICE

We recommend that always maintain correct air pressure in tyres. Incorrect air pressure may cause to uncomfortable riding, tyre life reduction and low mileage.

This vehicle is fitted with tubeless tyre in both wheels. Compared with ordinary tube tyre, the tubeless tyre releases slow air leak when punctured by a nail or other similar object. For this reason, even though

they remain fully inflated, it is important to regularly check the tyre for embedded objects.

Inspection

Whenever you check the tyre pressures, you should also examine the tyre treads and sidewalls for wear, damage, and foreign objects:

Look for:

- Bumps or bulges in the side of the tyre or the tread. Replace the tyre if you find any bumps or bulges.
- Cuts, splits or cracks in the tyre. Replace the tyre if you can see fabric or cord.
- Excessive tread wear.

Also, if you hit a pothole or hard object, pull to the side of the road as soon as you safely can and carefully inspect the tyres for damage.

Tread Wear

Replace tyres when tread reach to the wear indicator arrow.

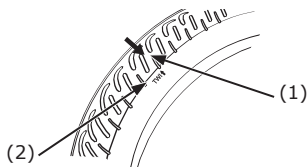

- (1) Wear indicator (वियर इंडिकेटर)
- (2) Wear indicator location mark
(वियर इंडिकेटर लोकेशन चिन्ह)

Tyre Repair

If a tubeless tyre is punctured or damaged, Please visit nearest tyre manufacture dealer and follow his recommendation of repair or replacement.

! CAUTION

Repair/Replacement of tubeless tyre by unauthorized person may render the tyre useless or tyre can fail while driving.

Tyre Replacement

The tyres that came on your vehicle were designed to match the performance capabilities of your vehicle and provide the best combination of handling, braking, durability and comfort.

! WARNING

Installing improper tyres on your vehicle can affect handling and stability. This can cause a crash in which you can be seriously hurt or killed.

Always use the size and type of tyres recommended in this owner's manual.

The recommended tyres for your vehicle are:

Front : 80/100-18M/C 47P

Rear : 80/100-18M/C 54P

Whenever you replace a tyre, use one that is equivalent to the original and be sure the wheel is balanced after the new tyre is installed.

ESSENTIAL INDIVIDUAL COMPONENTS

IGNITION SWITCH

The ignition switch (1) is below the speedometer.

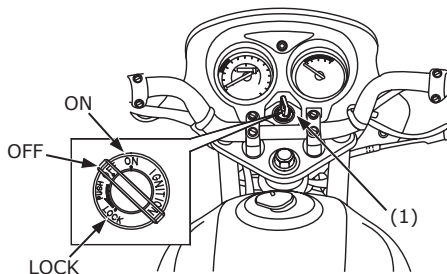

(1) Ignition switch (इग्निशन स्विच)

Key Position	Function	Key Removal
LOCK (steering lock)	Steering is Locked. Engine and lights cannot be operated.	Key can be removed
OFF	Engine and lights cannot be operated.	Key can be removed
ON	Engine and lights can be operated. Turn signal, passing light control switch and horn can be operated. The headlight, position light, taillight and meter lights operates only when the engine is running	Key cannot be removed

RIGHT HANDLEBAR CONTROL

START BUTTON

The start button (1) is next to the throttle grip.

When the start button is pressed, the starter motor cranks the engine. See page 31 for the starting procedure.

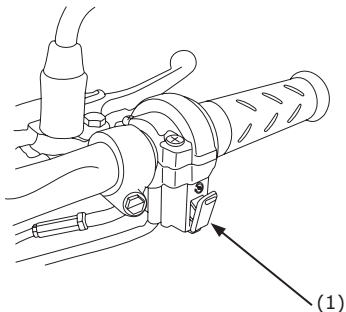

(1) Start button (स्टार्ट बटन)

LEFT HANDLEBAR CONTROLS

Headlight Switch (1)

The headlight switch (1) has three positions;  \supseteq and (●)

 : Headlight, position light, taillight and meter lights on.

\supseteq : Position light, taillight and meter light on.

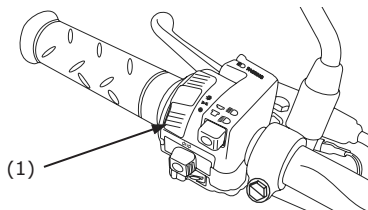

OFF (●) : Headlight, taillight and meter lights off.

The headlight, position light, taillight and meter lights operates only when the engine is running.





(1) Headlight switch (हेडलाइट स्विच)

Headlight Dimmer Switch (2)

Push the dimmer switch to  (HI) to select high beam or to  (LO) to select low beam

Turn Signal Switch (3)

Move to  (L) to signal a left turn,  (R) to signal a right turn. Press to turn off the signal.

Passing Light Control Switch (4)

When this switch is pressed, the headlight flashes on to signal approaching cars or when passing.

Horn Button (5)

Press the button to sound the horn.

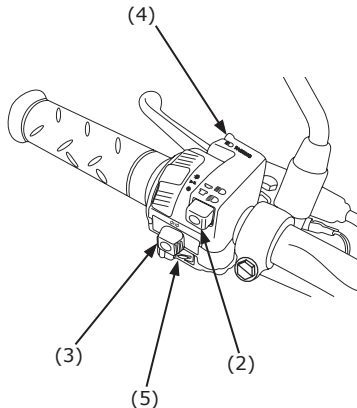

- (2) Headlight dimmer switch (हेडलाइट डिमर स्विच)
- (3) Turn signal switch (टर्न सिगनल स्विच)
- (4) Passing light control switch (पासिंग लाइट कंट्रोल स्विच)
- (5) Horn button (हॉर्न बटन)

FEATURES

(Not required for operation)

STEERING LOCK

To lock the steering, turn the handlebar all the way to the left or right, turn the ignition key (1) to LOCK position while pushing in. Remove the key. To unlock the steering, turn the key to OFF.

Do not turn the key to LOCK while riding the vehicle which may result loss of vehicle control.

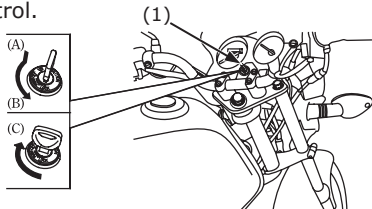

(1) Ignition key (इग्नीशन की)

(A) Push in(पुश-इन)

(B) Turn to LOCK (लॉक की ओर धुमारें)

(C) Turn to OFF (ऑफ की ओर धुमारें)

RIGHT SIDE COVER

The right side cover must be removed for battery, storage compartment and fuse maintenance.

Removal:

1. Insert the ignition key into the side cover key hole and turn it counterclockwise.
2. Carefully pull the right side cover (2) out from the grommet (3) and lugs (1) of the rear cowl.

Installation:

- Installation can be done in the reverse order of removal

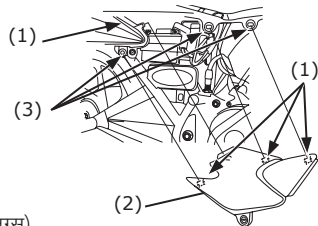

(1) Lugs (लग्स)

(2) Right Side cover (दायाँ साईड कवर)

(3) Grommet (ग्रॉमेट)

LEFT SIDE COVER

The left side cover must be removed for air cleaner element.

Removal:

1. Remove the screw (1).
2. Remove the left side cover (2) from the bosses (3) of the fuel tank and rear cowl.

Installation:

- Installation can be done in the reverse order of removal

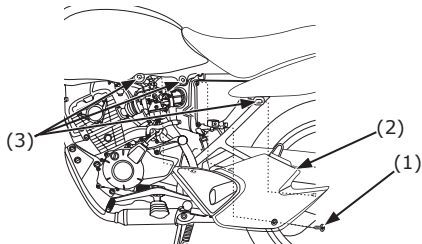

- (1) Screw (स्क्रू)
(2) Left Side cover (बायाँ साईड कवर)
(3) Bosses (बॉसिस)

STORAGE COMPARTMENT

The storage compartment (1) is located under the right side cover (page 27). This compartment is for light weight items.

Tool kit, first aid kit and documents should be stored in this light weight compartment.

While washing your vehicle, be careful not to flood this area with water.

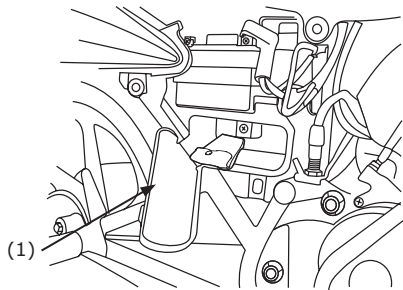

- (1) Storage compartment (स्टोरेज कम्पार्टमेंट)

HEADLIGHT AIM VERTICAL ADJUSTMENT

ADJUSTMENT

Vertical adjustment can be made by moving the headlight assy, as necessary.

To move the headlight assy, loosen the bolt (1). Tighten the bolt after adjustment.

Obey local laws and regulations.

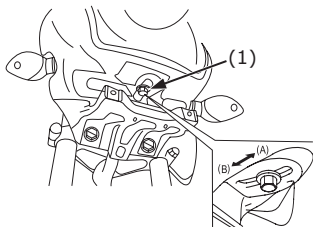

(1) Bolt (बोल्ट)

(A) Up (ऊपर)

(B) Down (नीचे)

OPERATION

PRE-RIDE INSPECTION

For your safety, it is very important to take a few moments before each ride to walk around your vehicle and check its condition. If you detect any problem, be sure you take care of it, or have it corrected by your Honda dealer.

! WARNING

Improperly maintaining this vehicle or failing to correct a problem before riding can cause a crash in which you can be seriously hurt or killed.

Always perform a pre-ride inspection before every ride and correct any problems.

1. Engine oil level- add engine oil if required (page 19). Check for leaks.
2. Fuel Level- fill fuel tank when necessary (page 18). Check for leaks.

3. Front and rear brakes.
Check operation and if necessary, adjust free play (page 13-15).
4. Tyres – check condition and pressure (page 21 –22).
5. Drive chain – check condition and slackness (page 51). Adjust and lubricate if necessary.
6. Throttle- check for smooth opening and full closing in all steering positions.
7. Clutch- check operation, and adjust if necessary (page 16).
8. Lights and horn – check these turn signals, indicators and horn function properly.

STARTING THE ENGINE

Always follow the proper starting procedure described below.

The vehicle can also be started with the transmission in gear by disengaging the clutch before operating the self starter.

Your vehicle's exhaust contains poisonous carbon monoxide gas. High level of carbon

monoxide can collect rapidly in enclosed areas such as a garage. Do not run the engine with the door open, run the engine only long enough to move your vehicle out of the garage.

Do not use the electric starter for more than 5 seconds at a time. Release the start button for approximately 10 seconds before pressing it again.

Do not operate the kick-starter while the engine is running as engine damage could result. Do not apply excessive force on the kick-starter.

Fold up the kick-starter after the kick-starter is returned to the pedal stop.

Preparation

Before starting, insert the key, turn the ignition switch ON and confirm the following:

- The transmission is in neutral (neutral indicator light ON).
- The fuel knob is ON.

Starting Procedure

Cold Engine:

1. Pull the choke lever (1) up all the way to fully ON.
2. With the throttle slightly open, press the start button.
(or use the kickstarter)
Lightly depress the kick-starter until resistance is left.
Then let the kick-starter return to top of its stroke.
With the throttle slightly open, operate the kick starter.
Kick from the top of the through to the bottom with a rapid, continuous motion.
3. Immediately after the engine starts, push the choke lever down to the halfway position.

NOTICE

Extended use of the choke may impair piston and cylinder wall lubrication and damage the engine.

4. Warm up the engine by opening and closing the throttle slightly.
5. Continue warming up the engine until it runs smoothly and responds to the throttle, when the choke lever is at fully OFF.

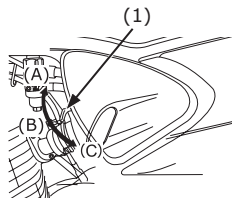

- (1) Choke Lever (चोक लीवर)
(A) Fully ON (पूर्णतया ऑन)
(B) Half ON (हॉफ ऑन)
(C) Fully OFF (पूर्णतया ऑफ)

Warm Engine

- (1) Do not use the choke.
- (2) Start the engine following step 2 under "Cold Engine".

FLOODED ENGINE

(Use the start button)

If the engine fails to start after repeated attempts, it may be flooded with excess fuel. To clear a flooded engine, turn the ignition switch to ON, and move the choke lever to fully OFF (C). Open the throttle fully and crank the engine for 5 seconds. If the engine starts, quickly close the throttle, then open it slightly if idling is unstable. If the engine does not start, wait 10 seconds, then follow the starting procedure.

(Use the kickstarter)

If the engine fails to start after several repeated attempts, it may have become flooded with excess fuel. To clear the engine, turn off the ignition switch and move the choke lever to fully OFF (C). Open the throttle fully and crank the engine several times with the kick-starter. Turn the ignition switch to ON and open the throttle slightly, start the engine using the kick-starter.

RUNNING- IN

Assure your vehicle's future reliability and performance by paying extra attention to how you ride during the first 500 km (300 miles).

During this period, avoid full-throttle starts and rapid acceleration.

RIDING

Review vehicle safety (pages 1-6) before you ride.

Make sure the side stand is fully retracted before riding the vehicle. If the stand is extended, it may interfere with control during a left turn.

1. After the engine has been warmed up, the vehicle is ready for riding.
2. While the engine is idling, pull in the clutch lever and depress gearshift pedal to shift into 1st (low) gear.
3. Slowly release the clutch lever and at the same time gradually increase engine speed by opening the throttle.

Coordination of the throttle and clutch lever will assure a smooth positive start.

4. When the vehicle attains a moderate speed, close the throttle, pull in the clutch Lever and shift to 2nd gear by raising the gearshift pedal. This sequence is repeated to progressively shift to 3rd and 4th (top) gears.
5. Coordinate the throttle and brakes for smooth deceleration.
6. Both front and rear brakes should be used at the same time and should not be applied strongly enough to lock the wheel, or braking effectiveness will be reduced and control of the vehicle be difficult.

SHIFTING

Proper shifting can prevent damaging the engine and transmission.

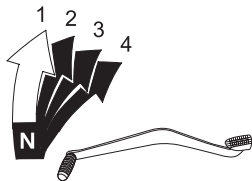

UPSHIFTING

The upper limit speed of each gear is shown in gear range (page 10).

Upshift to a higher gear before exceeding the upper limit speed.

Upshifting at speeds higher than the upper limit speed can cause damage to the engine.

DOWNSHIFTING

More higher downshifting speeds may overload the engine and can cause damage to the engine and transmission.

BRAKING

Your vehicle is equipped with mechanically-activated drum brakes. Operating the brake lever applies the front drum brake. Depressing the brake pedal applies the rear drum brake.

Important Safety Reminders:

- Independent operation of only the brake lever or brake pedal reduces stopping performance.
- Extreme application of the brake controls may cause wheel lock, reducing control of the vehicle.
- When possible, reduce speed or brake before entering a turn, closing the throttle or braking in mid-turn may cause wheel slip. Wheel slip will reduce control of the vehicle.
- When riding in wet or rainy condition, on loose surfaces, the ability to maneuver and stop will be reduced. All of your conditions, Rapid acceleration, braking or turning may cause loss of control. For your safety, exercise extreme caution when braking, accelerating or turning.
- When descending a long, steep grade, use engine compression braking by down-shifting with intermittent use of both brakes. Continuous brake application can overheat the brakes and reduce their effectiveness.
- Riding with your foot resting on the brake pedal or your hand on the brake lever may actuate the brake light, giving a false indication to other drivers; It may also overheat the brakes, reducing effectiveness.

PARKING

1. After stopping the vehicle, shift the transmission into neutral, turn the fuel cock OFF, turn the handle bar fully to the left or right, turn the ignition switch OFF and remove the key.
2. Use the centre stand to support the motorcycle while parked.

Park the vehicle on firm, level ground to prevent it from falling over.

If the vehicle is parked on a slight incline, aim the front of the vehicle uphill to reduce the possibility of rolling off the centre stand or overturning.

3. Lock the steering to help prevent theft (page 27).

ANTI-THEFT TIPS

1. Always lock the steering.
2. Never leave the key in the ignition switch. This sounds simple but people do forget.
3. Be sure the registration information for your vehicle is accurate and current.
4. Put your vehicle in a locked garage whenever possible.
5. Use an additional anti-theft device of good quality.
6. Put your name, address, phone number and key number in this Owner's Manual and keep it on your vehicle at all times.

Many times stolen vehicles are identified by information in the Owner's Manuals.

NAME: _____

ADDRESS: _____

PHONE NO: _____

MAINTENANCE

THE IMPORTANCE OF MAINTENANCE

A well-maintained vehicle is essential for safe, economical and trouble-free riding. It will also help reduce air pollution.

To help you properly care for your vehicle, the following pages include a Maintenance Schedule and a maintenance Record for regularly scheduled maintenance.

These instructions are based on the assumption that the vehicle will be used exclusively for its designed purpose. Sustained high speed operation or operation in unusually wet or dusty conditions will require more frequent service than specified in the Maintenance Schedule. Consult your Honda dealer for recommendations applicable to your individual needs and use.

If your vehicle overturns or becomes involved in a crash, be sure your Honda dealer inspects all major parts, even if you are able to make some repairs.



WARNING

Improperly maintaining this vehicle or failing to correct a problem before you ride can cause a crash in which you can be seriously hurt or killed.

Always follow the inspection and maintenance recommendations and schedules in this owner's manual.

MAINTENANCE SAFETY

This section includes instructions on some important maintenance tasks. You can perform some of these tasks with the tools provided if you have basic mechanical skills.

Other tasks that are more difficult and require special tools are best performed by professionals. Wheel removal should normally be handled only by a Honda technician or other qualified mechanic; instructions are included in this manual only to assist in emergency service.

Some of the most important safety precautions follow. However, we cannot

warn you of every conceivable hazard that can arise in performing maintenance. Only you can decide whether or not you should perform a given task.

WARNING

Failure to properly follow maintenance instructions and precautions can cause you to be seriously hurt or killed.

Always follow the procedures and precautions in this owner's manual.

SAFETY PRECAUTIONS

- Make sure the engine is off before you begin any maintenance or repairs. This will help eliminate several potential hazards:
- **Carbon monoxide poisoning from engine exhaust.**
Be sure there is adequate ventilation whenever you operate the engine.
- **Burns from hot parts.**
Let the engine and exhaust system cool before touching.

- **Injury from moving parts.**

Do not run the engine unless instructed to do so.

- Read the instructions before you begin, and make sure you have the tools and skills required.
- To help prevent the vehicle from falling over, park it on a firm, level surface, using the side stand or a maintenance stand to provide support.
- To reduce the possibility of a fire or explosion, be careful when working around petrol or batteries. Use only nonflammable solvent, not petrol, to clean parts. Keep cigarettes, sparks and flames away from the battery and all fuel-related parts.

Remember that your Honda dealer knows your vehicle best and is fully equipped to maintain and repair it.

To ensure the best quality and reliability, use only new genuine Honda parts or their equivalents for repair and replacement.

MAINTENANCE SCHEDULE

Perform the pre-ride Inspection (Ref. page 29) at each scheduled maintenance period.

I:INSPECT AND CLEAN, ADJUST, LUBRICATE OR REPLACE IF NECESSARY

C:CLEAN R:REPLACE A:ADJUST L:LUBRICATE.

The following Maintenance Schedule specifies all maintenance required to keep your vehicle in peak operating condition. Maintenance work should be performed in accordance with standards and specifications of Honda by properly trained and equipped technicians. Your Honda dealer meets all of these requirements.

- * Should be serviced by your Honda dealer, unless the owner has the proper tools and service data and is mechanically qualified. Refer to the Official Honda Shop Manual.
- ** In the interest of safety, we recommend these items be serviced only by your Honda dealer.

Honda recommends that your Honda dealer should road test your vehicle after each periodic maintenance is carried out.

- NOTES: (1) At higher odometer reading, repeat at the frequency interval established here.
(2) Service more frequently when riding in unusually wet or dusty areas.
(3) Service more frequently when riding in rain or at full throttle.
(4) Replacement requires mechanical skill.

ITEM	FREQUENCY	NOTE	PRE-RIDE CHECK	ODOMETER READING (NOTE 1)										ANNUAL CHECK	REGULAR REPLACE	REFER TO PAGE	
				X1000KM	1	4	8	12	16	20	24						
				X1000MI	0.6	2.5	5	7.5	10	12.5	15						
* FUEL LINE						I	I	I	I	I	I	I	I			-	
FUEL LEVEL			I													-	
* FUEL STRAINER SCREEN						C	C	C	C	C	C	C					
* THROTTLE OPERATION			I			I	I	I	I	I	I	I	I			50	
CHOKE OPERATION			I			I	I	I	I	I	I	I	I			31	
* AIR CLEANER	(NOTE 2)								R							50	
CRANKCASE BREATHER	(NOTE 3)					C	C	C	C	C	C	C	C			45	
SPARK PLUG						I	R	I	R	I	R					46	
* VALVE CLEARANCE						I	I	I	I	I	I	I				47	
ENGINE OIL			I			R	R	R	R	R	R	R	R			43	
** ENGINE OIL STRAINER SCREEN						C			C			C				-	
** ENGINE OIL CENTRIFUGAL FILTER									C			C				-	
* ENGINE IDLE SPEED						I	I	I	I	I	I	I	I			49	
* SECONDARY AIR SUPPLY SYSTEM										I			I			-	
DRIVE CHAIN			I			EVERY 1000 Km (600 mi) I, L											51
* BATTERY			I			I	I	I	I	I	I	I	I			61	

The vehicle must be serviced at every 4000 kms or within 4 months whichever is earlier from the date of previous service. For NOTES refer page 38.

ITEM	FREQUENCY	NOTE	PRE-RIDE CHECK	ODOMETER READING (NOTE 1)										ANNUAL CHECK	REGULAR REPLACE	REFER TO PAGE
				X1000KM	1	4	8	12	16	20	24					
				X1000MI	0.6	2.5	5	7.5	10	12.5	15					
			MONTHS	1	4	8	12	16	20	24						
BRAKE SHOES WEAR			I		I	I	I	I	I	I	I	I		61		
BRAKE SYSTEM			I	I	I	I	I	I	I	I	I	I		13		
BRAKE LIGHT SWITCH					I	I	I	I	I	I	I	I		65		
HEADLIGHT AIM					I	I	I	I	I	I	I	I		28		
LIGHTS/HORN			I											-		
CLUTCH SYSTEM			I	I	I	I	I	I	I	I	I	I		16		
SIDE STAND					I	I	I	I	I	I	I	I		57		
* SUSPENSION					I	I	I	I	I	I	I	I		12		
* NUTS, BOLTS, FASTENERS				I		I		I		I		I		-		
** WHEELS/TIRES			I		I	I	I	I	I	I	I	I		21		
** STEERING HEAD BEARINGS				I			I			I		I		-		

The vehicle must be serviced at every 4000 kms or within 4 months whichever is earlier from the date of previous service.

TOOL KIT

The tool kit (1) is in the storage compartment under the right side cover.

Some road side repairs, minor adjustments and parts replacement can be performed with the tools contained in the kit.

- 14 x 17 mm open end wrench
- Screwdriver
- Spark plug wrench
- Tool bag

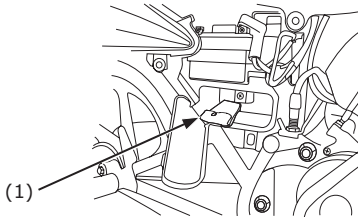

(1) Tool kit (टूल किट)

SERIAL NUMBERS

The frame and engine serial numbers are required when registering your vehicle. They may also be required by your dealer when ordering replacement parts.

Record the numbers here for your reference.

FRAME NO. _____

The frame number (1) is stamped on the right side of the steering head.

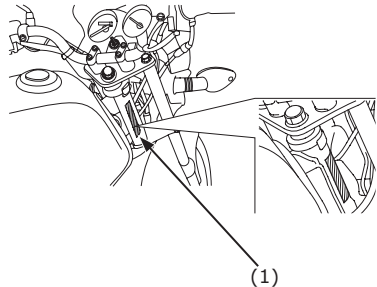

(1) Frame number (फ्रेम नम्बर)

The engine number (2) is stamped on the left side of the crankcase.

ENGINE NO. _____

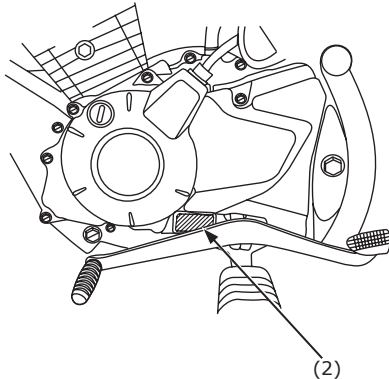

(2) Engine number (इंजन नम्बर)

COLOR CODE

The color table is attached below.

It is useful during ordering the replacement parts.

S. No.	Color	Color Code
1	Black	NH1
2	Sports red	R321
3	Pearl amazing white	NHB63

The above color code table helps in providing the correct color part as per your vehicle color.

ENGINE OIL

Refer to the Safety Precautions on page 37.

Engine Oil

Good engine oil has many desirable qualities. Use only high detergent, quality motor oil certified on the container to meet or exceed requirements for API Service Classification MA

Viscosity:

Viscosity grade of engine oil should be based on average atmospheric temperature in your riding area. The following provides a guide to the selection of the proper grade or viscosity of oil to be used at various atmospheric temperatures.

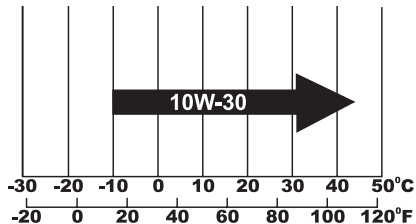

Recommended Oil

10W-30 MA

Engine Oil

Engine oil quality is the chief factor affecting engine service life. Change the engine oil as specified in the maintenance schedule (page 39).

When running in very dusty conditions, oil changes should be performed more frequently than specified in the maintenance schedule.

Please dispose of used engine oil in a manner that is compatible with the environment. We suggest you take it in a sealed container to your local recycling center or service station for reclamation. Do not throw it in the trash or pour it on the ground or down a drain.

Used engine oil may cause skin cancer if repeatedly left in contact with the skin for prolonged periods. Although this is unlikely unless you handle used oil on a daily basis,

NOTICE

*Always use Honda genuine engine oil.
It is still advisable to thoroughly wash your hands with soap and water as soon as possible after handling used oil.*

If a torque wrench is not used for this installation, see your Honda dealer as soon as possible to verify proper assembly.

Change the engine oil from the engine at normal operating temperature and the vehicle on its center stand to assure complete and rapid draining.

1. To drain the oil, remove the oil filler cap/dipstick and oil drain bolt (1) and sealing washer (2).
2. Operate the kickstarter several times to aid in complete draining of the remaining oil.
3. Check that the sealing washer (2) on the drain bolt is in good condition and install the bolt. Replace the sealing washer every other time the oil is changed, or each time if necessary.
Oil Drain Bolt Torque:
24 N.m (2.4 kgf.m, 17 lbf.ft)
4. Fill the crankcase with recommended grade oil; approximately:
0.9 ltr. (0.9 US qt, 0.8 Imp qt)
5. Install the oil filler cap/dipstick.
6. Start the engine and let it idle for 3-5 minutes.

7. 2-3 minutes after stopping the engine, check oil level with dipstick. It should be on upper level mark of the dipstick with vehicle standing upright confirm level ground. Make sure there are no oil leaks.

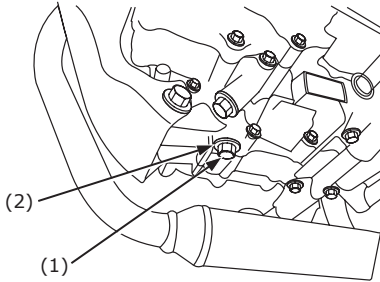

- (1) Oil drain bolt (ऑयल ड्रेन बोल्ट)
(2) Sealing washer (सीलिंग वाशर)

CRANKCASE BREATHER

Refer to the Safety Precautions on Page 37.

1. Remove the left side cover.
2. Remove the crankcase breather tube (1) from the air cleaner housing and drain deposits from the Air cleaner drain tube (2) into a suitable container.
3. Reinstall the crankcase breather tube.

Service more frequently when riding in rain, or at full throttle.

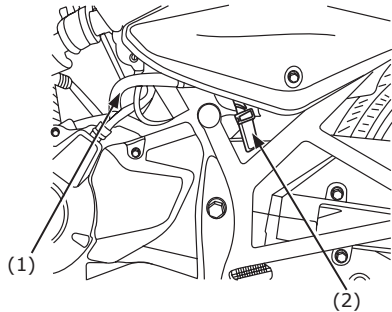

- (1) Crankcase breather tube (क्रैंक-केस ब्रीदर ट्यूब)
(2) Air cleaner drain tube (एयर क्लीनर ड्रेन ट्यूब)

SPARK PLUG

Refer to the safety precautions on page 37.
Recommended plugs:

Standard:
CPR7EA-9 (NGK)

NOTICE

Never use a spark plug with an improper heat range. Severe engine damage could result.

1. Disconnect the spark plug cap (1) from the spark plug.
2. Clean any dirt from around the spark plug base. Remove the spark plug using a spark plug wrench (2) and spanner (3) furnished in the tool kit.

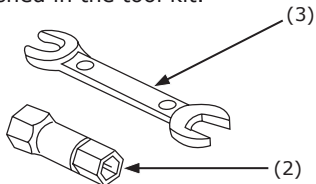

3. Inspect the electrodes and center porcelain for deposits, erosion or carbon fouling. If the erosion or deposit is heavy, replace the plug. Clean a carbon or wetfouled plug with a plug cleaner, otherwise use a wire brush.
4. Check the spark plug gap (4) using a wire-type feeler gauge. If adjustment is necessary, bend the side electrode (5) carefully.

The gap should be:

0.8–0.9 mm (0.031–0.035 in)

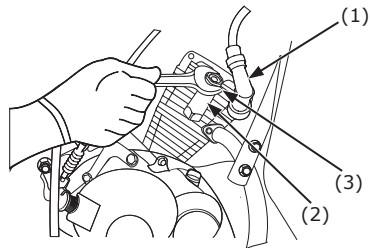

- (1) Spark plug Cap (स्पाक प्लग कैप)
- (2) Plug wrench (प्लग रेंच)
- (3) Spanner (स्पेनर)

5. Make sure the plug washer is in good condition.
6. Washer of the plug attached thread the spark plug in by hand prevent cross threading.

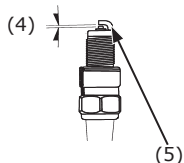

(4) Spark plug gap (स्पार्क प्लग गैप)

(5) Side electrode (साईड इलेक्ट्रोड)

7. Tighten the spark plug:
 - If the old plug is good
1/8 turn after it seats.
 - If installing a new plug, tighten it twice to prevent loosening:
 - a) First tighten the plug:
NGK:1/2 turn after it seats.
 - b) Then loosen the plug.
 - c) Next, tighten the plug again:
1/8 turn after it seats.

NOTICE

Improperly tightened spark plug:-

- *Too loose:- Can damage the engine or can burn a piston.*
- *Too tight:- Can damage the threads of cylinder head.*

8. Reinstall the spark plug cap. Take care to avoid pinching any cables or wires.

VALVE CLEARANCE

Should be serviced by your Honda dealer, unless the owner has the proper tools and service data and is mechanically qualified. Refer to the Official Honda Shop Manual.

Excessive valve clearance will cause noise and eventual engine damage. Little or no clearance will prevent the valve from closing and cause valve damage and power loss. Check the valve clearance at the specified intervals when the engine is in cold condition.

The checking or adjusting of the clearance should be performed while the engine is cold.

The clearance will change as the engine temperature rises.

The adjustment must be made when the piston is at the top of the compression stroke when both the intake and exhaust valves are closed.

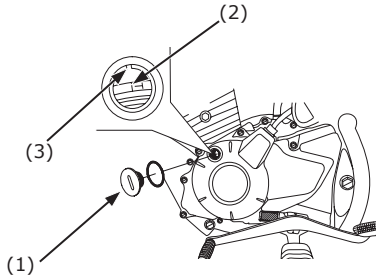

(1) Timing hole cap (टाइमिंग होल कैप)

(2) "T" mark ('टी' मार्क)

(3) Index mark (इंडेक्स मार्क)

This condition can be determined by moving the rocker arms. If they are free, it is an indication that the valves are closed

and that the piston is on the compression stroke. If they are tight and the valves are open, rotate the flywheel 360 degree and realign the "T" mark to the index mark.

Check the clearance of both valves by inserting a feeler gauge between the adjusting screw and the valve stem.

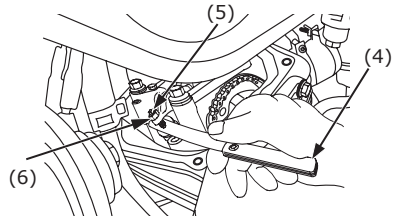

(4) Feeler gauge (फीलर गेज)

(5) Adjusting screw (एडजस्टिंग स्कू)

(6) Adjusting screw lock nut (एडजस्टिंग स्कू लॉक नट)

Clearance should be:

Intake: 0.10 mm (0.004 in)

Exhaust: 0.15 mm (0.006 in)

Finally, recheck the clearance to make sure that adjusting has not been disturbed.

IDLE SPEED

Refer to the safety precautions on page 37. The engine must be at normal operating temperature for accurate idle speed adjusting. 10 minutes of stop-and-go riding is sufficient.

Do not attempt to compensate for faults in other systems by adjusting idle speed. See your Honda dealer for regularly scheduled carburetor adjustments.

1. Warm up the engine, shift to neutral and place the vehicle on its center stand.
2. Connect a tachometer to the engine.
3. Adjust idle speed with the throttle stop screw (1).

Idle speed (In neutral):

1400±100 min-1(rpm)

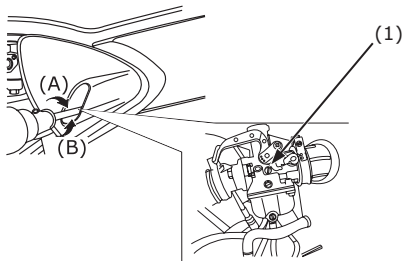

(1) Throttle stop screw (थ्रॉटल स्टॉप स्कू)

(A) Decrease (घटाएँ)

(B) Increase (बढ़ाएँ)

THROTTLE OPERATION

Refer to the safety Precautions on page 37.

1. Check for smooth rotation of the throttle grip from the fully open to the fully closed position at both full steering positions.
2. Measure the throttle grip freeplay at the throttle grip flange.

The standard free play should be:

2-6 mm (0.08-0.24 in)

To adjust the freeplay, loosen the lock nut (1) and turn the adjuster (2).

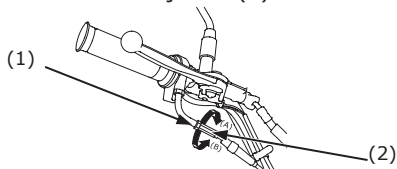

- (1) Lock nut (लॉक नट) (2) Adjuster (एडजस्टर)
(A) Decrease (घटाएँ) (B) Increase (बढ़ाएँ)

AIR CLEANER

Refer to the Safety Precautions on page 37.
The air cleaner element should be replaced

at regular intervals (page 39). Replace more frequently when riding in unusually wet or dusty areas.

1. Remove the bolts and left side cover from the grommets page 28.
2. Remove the bolt (1 no.) and screws (2 nos.) to pull out the left rear cowl.
3. Loosen the screws (4 nos.) and remove the air cleaner cover (2).
4. Take out the air cleaner element (3) and replace.

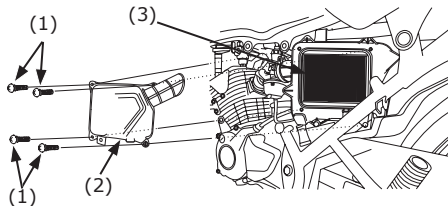

- (1) Screws (स्क़रूस)
(2) Air cleaner cover (एयर क्लीनर कवर)
(3) Air cleaner element (एयर क्लीनर एलीमेंट)

5. Viscous type air filters should be replaced regularly. Do not reuse it by cleaning.
6. If the filter element is cleaned using pressured air or any solvent, viscous oil will be lost and as the base element is coarse paper, dust may enter along with air which will damage the engine.
7. Replace the air cleaner element if it is excessively dirty, torn or damage. Use Honda genuine air cleaner element specified for your model. Using the wrong Honda air cleaner element or a non-Honda air cleaner element which is not of equivalent quality may cause premature engine wear or performance problem.
8. Install the removed parts in the reverse order of removal.

⚠ CAUTION

Do not use air, oil, water for cleaning of air cleaner element. Replacement should be done at regular intervals.



DRIVE CHAIN

Refer to the safety precautions on page 37.

The service life of the drive chain is dependent upon proper lubrication and adjustment. Poor maintenance can cause premature wear or damage to the drive chain and sprockets.

The drive chain should be checked and lubricated as part of the pre-ride Inspection (page 29). Under severe usage, or when the vehicle is ridden in unusually dusty or muddy areas, more frequent maintenance will be necessary.

Inspection:

1. Turn the engine off, place the vehicle on its side stand, and shift the transmission into neutral.

- Remove the inspection cap (1). Move the chain up and down with your finger. Drive chain slack should be adjusted approximately to allow the following vertical movement by hand:

Chain slack should be:

25-35 mm (0.98 - 1.38 in)

- Rotate the rear wheel. Stop, Check the drive chain slackness. Repeat this procedure several times. Drive chain slack should remain constant. If the chain is slack only in certain sections, some links are kinked and binding. Binding and kinking can be eliminated by lubrication.

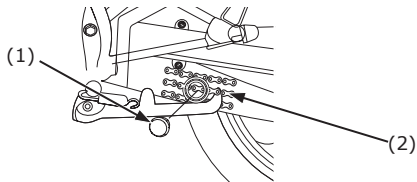

- (1) Inspection cap (निरीक्षण कैप)
 (2) Drive chain (ड्राइव चैन)

- Remove the bolts (3).
- Press the lugs (4).
- Release all the claws (7) from both the chain case covers and carefully remove them from swing arm assembly to expose the drive chain.

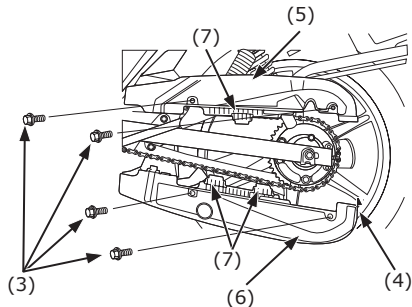

- (3) Bolts (बोल्ट्स)
 (4) Lugs (लग्स)
 (5) Upper chain case (ऊपरी चैन केस)
 (6) Lower chain case (निचला चैन केस)
 (7) Claws (क्लॉज)

7. Inspect the sprocket teeth for possible wear or damage. Replace if necessary.

Damaged sprocket
Teeth
Replace

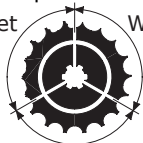

Worn sprocket
Teeth
Replace

Normal sprocket Teeth
GOOD

If the drive chain or sprockets are excessive worn or damaged, they should be replaced. Never use a new chain with worn sprockets; rapid chain wear will result.

8. Install the chain cases and inspection cap.

LOWER CASE

9. First install into the swing arm by widening the front side of lower case by hand into the stay on swing arm cross plate.

10. Fasten the lower case with two bolts.

UPPER CASE

11. Install the upper case into the swing arm by prefiting all claws of the upper case with ones of the lower case.

12. Right side of case - Total 5 claws (Front-1, Mid-3, Rear-1)

13. Left side of case - Total 1 claws (Front-1)

14. Visually confirm that all claws are installed correctly.

15. Fasten all 4 bolts.

Adjustment:

Drive chain slack should be checked and adjusted, if necessary, every 1000 km (600 miles). When operated at sustained high speeds or under conditions of frequent rapid acceleration, the chain may require more frequent adjustment.

If the drive chain requires adjustment, the procedure is as follows:

1. Place the vehicle on its center stand with the transmission in neutral and the ignition switch OFF.

2. Loosen the Rear axle nut (1) and sleeve nut (2).
3. Loosen the drive chain lock nuts (6).
4. Turn both drive chain adjusting nuts (3) an equal number of turns until the correct drive chain slack is obtained. Turn the adjusting nuts clockwise to tighten the chain, or counterclockwise to provide more slack.

Align the chain adjuster index marks (4) with the rear edge (5) of the adjusting slots on both sides of the swing arm.

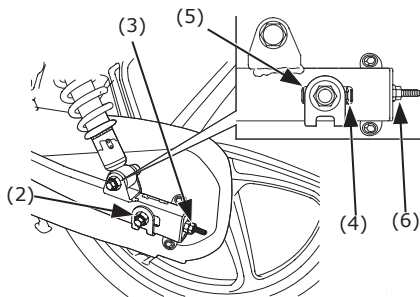
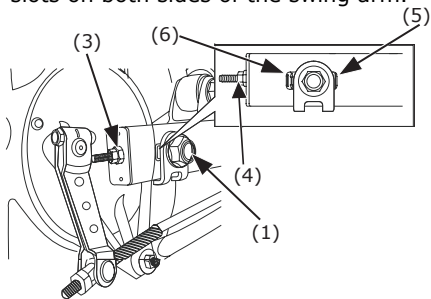

- (1) Rear Axle nut (रियर एक्सल नट)
- (2) Sleeve nut (स्लीव नट)
- (3) Drive chain adjusting nut (ड्राइव चेन एडजस्टिंग नट)
- (4) Index marks (इंडेक्स मार्क्स)
- (5) Rear edge of adjusting slot (एडजस्टिंग स्लाट का पिछला किनारा)
- (6) Drive chain lock nuts (ड्राइव चेन लॉक नट्स)

If the drive chain slack is excessive when the rear axle is moved to the furthest limit

of adjustment, the drive chain is worn and must be replaced.

5. Tighten the sleeve nut to:

44 N.m (4.5 kgf.m, 32 lbf.ft)

Tighten the rear axle nut:

54 N.m (5.9 kgf.m, 43 lbf.ft)

If the torque wrench is not used for this installation, see your Honda dealer as soon as possible to verify proper assembly.

6. Tighten the adjusting nuts lightly, then tighten the lock nuts by holding the adjusting nuts with a spanner.

7. Recheck drive chain slack.

8. Rear brake pedal freeplay is affected when repositioning the rear wheel to adjust drive chain slack. Check rear brake pedal freeplay and adjust as necessary (page 15).

Lubrication and Cleaning:

Lubricate every 1000 km (600 miles) or sooner if chain appears dry.

To clean and lubricate the chain visit your nearest Honda Dealer/Service Center.

Replacement chain: 420AD-118

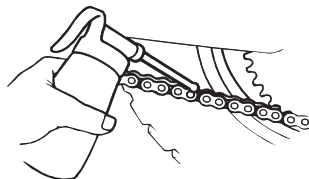

NOTICE

Improper maintenance of chain can lead to premature wear of sprockets and chain drive.

Removal and Cleaning:

When the drive chain becomes dirty, it should be removed and cleaned prior to lubrication.

1. With the engine off, Remove the drive chain cases and carefully remove the master link retaining clip (1) with a pair of pliers. Do not bend or twist the clip. Remove the master link. Remove the drive chain from the vehicle.
2. Clean the drive chain in high flash-point solvent and allow it to dry. Inspect the

damaged rollers, loose fitting links or otherwise appears unserviceable.

3. Inspect the sprocket teeth for possible wear or damage. Replace if necessary.

Never use a new drive chain on badly worn sprockets. Both chain and sprockets must be in good condition, or the new replacement chain or sprocket will wear rapidly.

4. Lubricate the drive chain (page 55).
5. Pass the chain over the sprockets and join the ends of the chain with the master link. For ease of assembly, hold the chain ends against adjacent rear sprocket teeth while inserting the master link.

The master link is the most critical part affecting the security of the drive chain. Master links are reusable, if they remain in excellent condition, but it is recommended that a new master link retaining clip be installed whenever the drive chain is reassembled.

Install the master link retaining clip so

that the closed end of the clip will face the direction of forward wheel rotation.

6. Adjust the drive chain (page 54) and rear brake pedal free play.
7. Install the drive chain cases.

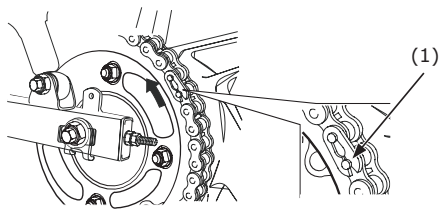

(1) Retaining Clip (रिटेनिंग क्लिप)

FRONT AND REAR SUSPENSION INSPECTION

Refer to the Safety Precautions on page 37.

1. Check the front fork assembly by locking the front brake and pumping the fork up and down vigorously. Suspension action should be smooth and there must be no oil leakage.

2. Swing arm bearings - this can be checked by pushing hard against the side of the rear wheel while the vehicle is on a Center stand. Freeplay indicates worn bearings.
3. Carefully inspect all front and rear suspension fasteners for tightness.

SIDE STAND

Refer to the Safety Precautions on page 37.

Check the side stand spring (1) for damage and loss of tension, and the side stand assembly for freedom of movement.

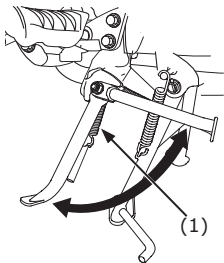

(1) Side stand spring (साइड स्टैन्ड स्प्रिंग)

If the side stand is squeaky or stiff, clean the pivot area and lubricate the pivot bolt with clean engine oil.

WHEEL REMOVAL

Refer to the Safety Precautions on page 37.

Front Wheel Removal

1. Place the vehicle on its center stand.
2. Raise the front wheel off the ground by placing a support block under the engine.
3. Remove the speedometer cable (1) by pushing the tab (2).
4. Remove the front brake adjusting nut (3) and remove the front brake cable (4) from the brake arm (5).
5. Remove the front axle nut (6).
6. Remove the front axle shaft (7) and the wheel.

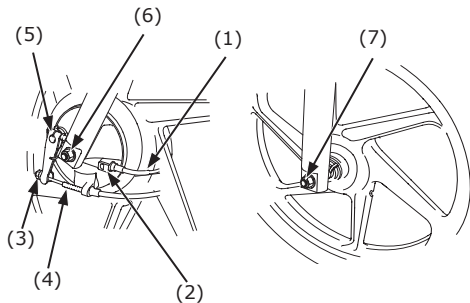

- (1) Speedometer cable (स्पीडोमीटर केबल)
- (2) Tab (टैब)
- (3) Brake adjusting nut (ब्रेक एडजस्टिंग नट)
- (4) Front brake cable (फ्रंट ब्रेक केबल)
- (5) Brake arm (ब्रेक आर्म)
- (6) Front axle nut (फ्रंट एक्सल नट)
- (7) Front axle shaft (फ्रंट एक्सल शाफ्ट)

Installation Notes:

1. Reverse the removal procedure.
2. Position the wheel between the fork legs and insert the front axle shaft from the right side, through the right fork leg and wheel hub.

Make sure that the tang (8) on the left front fork leg is located in the slot (9) in the brake panel.

3. Tighten the front axle nut to the specified torque.

Front axle nut torque:

54 N·m (5.5 kgf·m , 40 lbf·ft)

Adjust the brake (page 14).

After installing the wheel, apply the brake several times and then check if the wheel rotates freely. Recheck the wheel if the brake drags or if the wheel does not rotate freely.

If a torque wrench was not used for installation, see your Honda dealer as soon as possible to verify proper assembly.

Improper assembly may lead to loss of braking capacity.

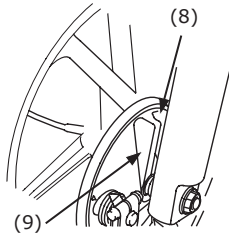

(8) Tang (टैंग)

(9) Slot (स्लॉट)

Rear Wheel Removal

1. Place the vehicle on its center stand.
2. Remove the drive chain cases page 51.
3. Remove the rear brake adjusting nut (1). Disconnect the brake rod (2) from the brake arm (3).
4. Disconnect the brake stopper arm (4) from the brake panel by removing the cotter pin (5), stopper arm nut (6).
5. Loose the drive chain lock nuts (7) and drive chain adjusting nut (8).

6. Remove the rear axle nut (9) and sleeve nut (10).
7. Remove the drive chain (11) from the driven sprocket by pushing the rear wheel forward.

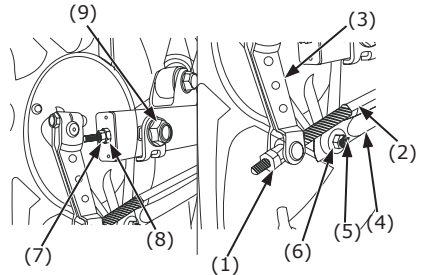

- (1) Brake adjusting nut (ब्रेक एडजस्टिंग नट)
- (2) Brake rod (ब्रेक रोड) (3) Brake arm (ब्रेक आर्म)
- (4) Brake stopper arm (ब्रेक स्टापर आर्म)
- (5) Cotter pin (कोटर पिन)
- (6) Stopper arm nut (स्टॉपर आर्म नट)
- (7) Drive chain lock nut (ड्राइव चेन लॉक नट)
- (8) Drive chain adjusting nut (ड्राइवचेन एडजस्टिंग नट)
- (9) Rear axle nut (रियर एक्सल नट)

8. Remove the rear axle shaft (12), side collar and rear wheel from the swingarm.

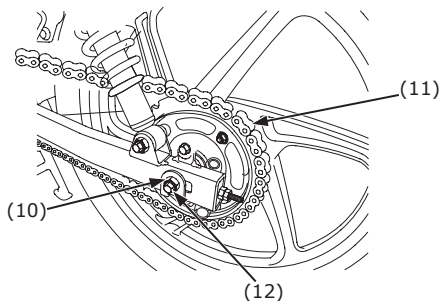

- (10) Sleeve nut (स्लीव नट)
(11) Drive chain (ड्राइव चेन)
(12) Rear axle shaft (रियर एक्सल शाफ्ट)

Installation Notes

To install the rear wheel, reverse the removal procedure.

- Tighten the rear axle nut, sleeve nut and brake stopper arm nut to specified torque.

Rear axle nut torque:

54 N.m (5.5 kgf.m, 43 lbf.ft)

Sleeve nut torque:

44 N.m (4.5 kgf.m, 32 lbf.ft)

Brake stopper arm nut torque:

22 N.m (2.2 kgf.m, 16 lbf.ft)

- Adjust the brake (page 15) and drive chain (page 51).
- After installing the wheel, apply the brake several times and then check if the wheel rotates freely. Recheck the wheel if the brake drags or if the wheel does not rotate freely.
- Always replace used cotter pins with new ones.

If a torque wrench was not used for installation, see your Honda dealer as soon as possible to verify proper assembly. Improper assembly may lead to loss of braking capacity.

BRAKE SHOE WEAR

Refer to the safety precautions on page 37.

The front and rear brakes are equipped with brake wear indicators.

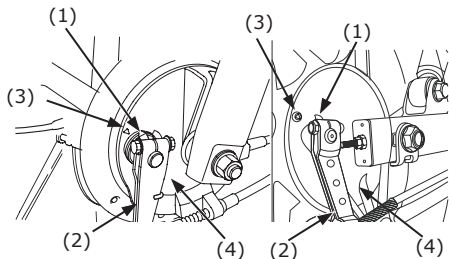

- (1) Arrow (तीर का निशान)
- (2) Brake arm (ब्रेक आर्म)
- (3) Reference mark (संदर्भ मार्क)
- (4) Brake panel (ब्रेक पैनल)

BATTERY

Refer to the safety precautions on page 37.

It is not necessary to check the battery electrolyte level or add distilled water as

the battery is a maintenance-free (sealed) type. If your battery seems weak and/or is leaking electrolyte (causing hard starting or other electrical troubles), contact your Honda dealer or battery manufacturer.

NOTICE

Your battery is maintenance-free type and can be permanently damaged if the cap strip is removed.



This symbol on the battery means that this product must not be treated as household waste.

NOTICE

Battery contains lead, which is a hazardous material and if improperly disposed, can be harmful to the environment and human health.

Always return the used maintenance-free battery to the Honda dealer.

WARNING

The battery gives off explosive hydrogen gas during normal operation.

A spark or flame can cause the battery to explode with enough force to kill or seriously hurt you.

Wear protective clothing and a face shield or have a skilled mechanic do the battery maintenance.

Keep children away from the battery.

Removal

1. Make sure the ignition switch is OFF.
2. Remove the right side cover (page 27).
3. Remove the bolt (4) and screws (2 nos.) (1) and remove the rear cowl (7).
4. Open the battery band and disconnect the negative (-) terminal lead (5) from the battery, first.
5. Disconnect the positive (+) terminal lead (8).
6. Pull out the battery (6) from the battery box.

Installation

1. Reinstall in the reverse order of removal. Be sure to connect the positive (+) terminal first, then the negative (-) terminal.
2. Check all bolts and other fasteners are secure.

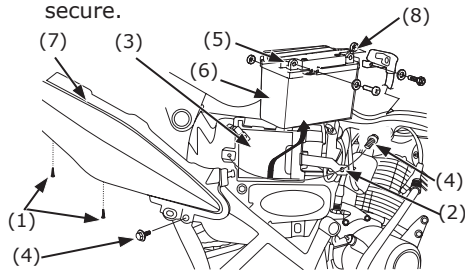

- (1) Screws (स्क़ूस)
- (2) Battery Band (बैटरी बैंड)
- (3) Battery holder (बैटरी होल्डर)
- (4) Bolt (बोल्ट)
- (5) Negative (-) terminal lead (नैगेटिव (-) टर्मिनल लीड)
- (6) Battery (बैटरी)
- (7) Rear cowl (रियर काऊल)
- (8) Positive (+) terminal lead (पाजिटिव (+) टर्मिनल लीड)

FUSE REPLACEMENT

Refer to the safety precautions on page 37. When frequent fuse failure occurs, it usually indicates a short circuit or an overload in the electrical system. See your Honda dealer for repair.

NOTICE

Never use a fuse with a different rating from that specified. Serious consequence to the electrical system or a fire may result, causing a dangerous loss of lights or engine power.

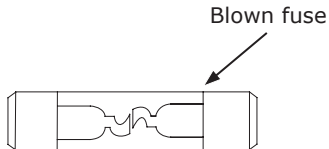

Fuse holder

The fuse holder located near the battery. The specified fuse is:

10A-(Both kick and self)

1. Turn the ignition switch OFF before checking or replacing the fuses to prevent an accidental short-circuit.
2. Remove the right side cover (page 27).

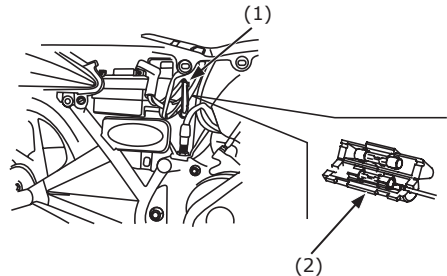

- (1) Fuse holder (फ्यूज होल्डर)
(2) Spare fuse (स्पेयर फ्यूज)

3. Open the fuse holder (1).
4. Pull out the old fuse and install a new fuse. The spare fuse (2) is attached to the fuse holder.
5. Install the fuse holder and right side cover.

Removal
Pull

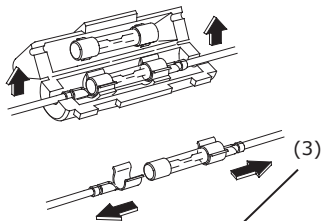

Installation
Push

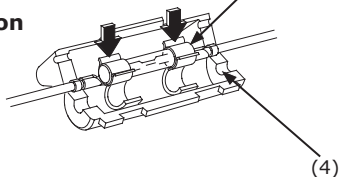

- (3) Fuse (फ्यूज)
(4) Clips (किलप्स)

Do not try to open the clips, which prevent fuse from coming out; you could bend them and cause poor contact with the new fuse. A loose fuse could cause damage to the electrical system and even start a fire.

If you do not have a replacement fuse with the proper rating for the circuit, install one with a lower rating.

NOTICE

Replacing a fuse with one that has a higher rating greatly increases the chance of damage to the electrical system.

If the replacement fuse of the same rating burns out in a short time, there is probably a serious electrical problem on your vehicle. leave the blown fuse in that circuit and have your vehicle checked by your Honda dealer.

MAIN FUSE

The main fuse (1) is located near the battery.

The specified fuse is:

15A (Both kick and self)

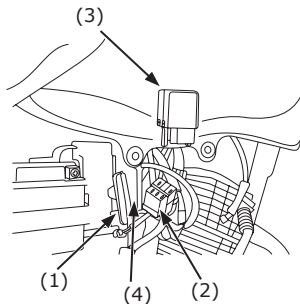

- (1) Main fuse (मेन फ्यूज)
- (2) Wire connector (वायर कनेक्टर)
- (3) Relay comp start - Self drum
(रिले कॉम्प स्टार्ट - सेल्फ ड्रम)
- (4) Spare main fuse (स्पेयर मेन फ्यूज)

1. Turn the ignition switch OFF before checking or replacing the fuses to prevent an accidental short-circuit.
2. Remove the right side cover (pages 27).
3. Disconnect the wire connector (2) of the relay comp start-self drum (3).
4. Pull out the old fuse. If the main fuse is blown install a new fuse. The spare fuse (4) is located near the battery
5. Reconnect the wire connection and install the right side cover.

BRAKE LIGHT SWITCH ADJUSTMENT

Refer to the safety Precautions on page 37.
Check the operation of the brake light switch (1) at the right side behind the engine from time to time.

Adjustment is done by turning the adjusting nut (2). Turn the nut in the clockwise direction (A) if the switch operates too late and in counterclockwise direction (B) if the switch operates too soon.

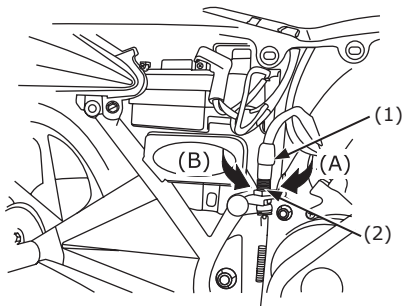

- (1) Brake light switch (ब्रेक लाइट स्विच)
(2) Adjusting nut (एडजस्टिंग नट)

BULB REPLACEMENT

Refer to the Safety Precautions on page 37.

The light bulb becomes very hot while the light is ON, and remains hot for a while after it is turned OFF. Be sure to let it cool down before servicing.

Do not put finger prints on the headlight bulb, as they may create hot spots on the bulb and cause it to break.

Wear clean gloves while replacing the bulb.

If you touch the bulb with your bare hands, clean it with a cloth moistened with alcohol to prevent its early failure.

- Be sure to turn the ignition switch OFF when replacing the bulb.
- Do not use bulbs other than those specified.
- After installing a new bulb, check that the light operates properly.

POSITION LIGHT BULB

1. Remove the front cowl (1) by removing the screws (5 nos.) (2).
2. Disconnect the connector (3).
3. Pull out the position light bulb (4) out of the head light unit and remove the bulb from its holder.
4. Install a new bulb in the reverse order of removal.

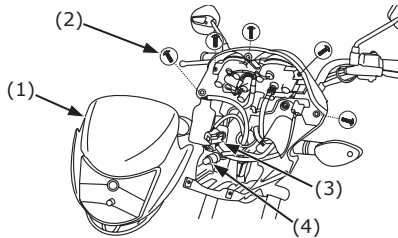

- (1) Front cowl (फ्रंट काउल)
- (2) Screws (स्क़ूस)
- (3) Connector (कनवेटर)
- (4) Position light bulb (पोजिशन लाइट बल्ब)

HEADLIGHT BULB

1. Remove the front cowl (page 67).
2. Disconnect the connector.
3. Remove the dust cover (5).
4. Remove the bulb (6) while pressing down the locking pin (7).
5. Install a new bulb in the reverse order of removal.
6. Install the dust cover with its "TOP" mark (8) facing up.

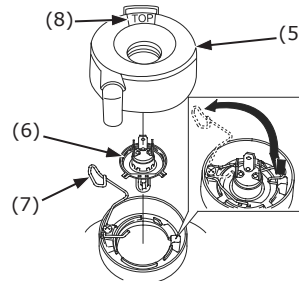

- (5) Dust cover (डस्ट कवर)
- (6) Bulb (बल्ब)
- (7) Locking pin (लॉकिंग पिन)
- (8) "Top" mark ("टॉप" मार्क)

BRAKE/TAIL LIGHT BULB

1. Remove the screws (1).
2. Remove the taillight lens (2).
3. Slightly press the bulb (3) and turn it counterclockwise.
4. Install a new bulb in the reverse order of removal.

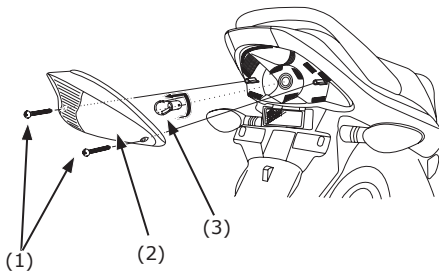

- (1) Screws (स्क़ूस)
(2) Taillight lens (टेल लाइट लेंस)
(3) Bulb (बल्ब)

FRONT/REAR TURN SIGNAL BULB

1. Remove the turn signal lens (1) by removing the screw (2).
2. Slightly press the bulb (3) and turn it counterclockwise.
3. Install a new bulb in the reverse order of removal.

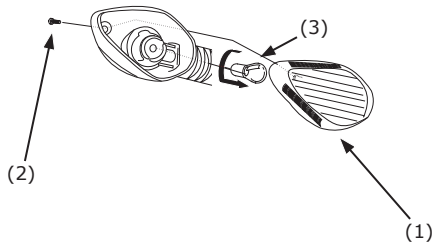

- (1) Turn signal lens (टर्न सिगनल लेंस)
(2) Screw (स्क़ूस)
(3) Bulb (बल्ब)

Cleaning

Clean your vehicle regularly to protect the surface finishes and inspect for damage, wear, and oil leakage.

Avoid cleaning products that are not specifically designed for motorcycle or automobile surfaces.

They may contain harsh detergents or chemical solvents that could damage the metal, paint, and plastic on your vehicle.

If your vehicle is still warm from recent operation, give the engine and exhaust system time to cool off.

We do not recommend the use of high pressure water spray.

NOTICE

High pressure water (or air) can damage certain parts of the vehicle.

Washing the vehicle

1. Rinse the vehicle thoroughly with cool water to remove loose dirt.
2. Clean the vehicle with a sponge or soft cloth using cool water.

Avoid directing water to muffler outlets and electrical parts.

3. Clean the plastic parts using a cloth or sponge dampened with a solution of mild detergent and water. Rub the soiled area gently rinsing it frequently with fresh water.

Take care to keep chemical solvents off the vehicle.

They will damage the plastic and painted surfaces.

Inside of the headlight lens may be clouded immediately after washing the vehicle. Moisture condensation inside the headlight lens will disappear gradually by lighting the headlight on high beam.

4. After cleaning, rinse the vehicle thoroughly with plenty of clean water. strong detergent residue can corrode alloy parts.
5. Dry the vehicle, start the engine, and let it run for several minutes.
6. Test the brakes before riding the vehicle. Several applications may be necessary to restore normal braking performance.
7. Lubricate the drive chain immediately after washing and drying the vehicle.

Braking efficiency may be temporarily impaired immediately after washing the vehicle.

Anticipate longer stopping distance to avoid possible accident.

Finishing Touches

After washing your vehicle, consider using a commercially-available spray cleaner/ polish or quality liquid or paste wax to finish the job. Use only a non-abrasive polish or wax made specifically for vehicle or automobiles. Apply the polish or wax according to the instructions on the container.

Removing Road Salt

The salt contained in the road surface freezing prevention medicine which a road was sprayed with in winter, and the seawater becomes the cause which rust occurs in.

Wash your vehicle by the following point after it runs through such a place.

1. Clean the vehicle using cool water (Ref. page 69).
Do not use warm water.
This worsens the effect of the salt.
2. Dry the vehicle and to protect surface of metal, apply wax on it.

STORAGE GUIDE

Extended storage, such as for winter, requires that you take certain steps to reduce the effects of deterioration from non-use of the vehicle. In addition necessary repairs should be made BEFORE storing the vehicle, otherwise, these repairs may be forgotten by the time the vehicle is removed from storage.

STORAGE

1. Change the engine oil.
2. Empty the fuel tank into an approved petrol container using a commercially available hand siphon or an equivalent method. Spray the inside of the tank with an aerosol rust-inhibiting oil.

Reinstall the fuel fill cap on the tank.

To assure proper performance after storage lasting more than one month, it is important to drain the carburetor.



WARNING

Petrol is highly flammable and explosive. You can be burned or seriously injured when handling fuel.

- Stop the engine and keep heat, sparks, and flame away.
- Refuel only outdoors.
- Wipe up spills immediately.

3. To prevent rusting in the cylinder, perform the following:
 - Remove the spark plug cap from the spark plug. Using tape or string, secure the cap to any convenient plastic body part so that it is positioned away from the spark plug.
 - Remove the spark plug from the engine and store it in a safe place. Do not connect the spark plug to the spark plug cap.
 - Pour a tablespoon (15-20 cm³) of clean engine oil into the cylinder and cover the spark plug hole with a piece of cloth.

- Crank the engine several times to distribute the oil.
- Reinstall the spark plug and spark plug cap.
- 4. Remove the battery. Store in an area protected from freezing temperatures and direct sunlight.
- 5. Wash and dry the vehicle. Wax all painted surfaces. Coat chrome with rust inhibiting oil.
- 6. Lubricate the drive chain (page 55).
- 7. Inflate the tyres to their recommended pressures. Place the vehicle on blocks to raise both tyres off the ground.
- 8. Cover the vehicle (don't use plastic or other coated materials) and store in an unheated area, free of dampness with a minimum of daily temperature variation. Do not store the vehicle in direct sunlight.

REMOVAL FROM STORAGE

1. Uncover and clean the vehicle.
Change the engine oil if more than 4 months have passed since the start of storage.
2. Check the battery voltage level and charge the battery as required. Install the battery.
3. Drain any excess aerosol rust-inhibiting oil from the fuel tank. Fill the fuel tank with fresh petrol.
4. Perform all Pre-ride Inspection checks (page 29)

Test ride the vehicle at low speeds in a safe riding area away from traffic.

SPECIFICATIONS

DIMENSIONS

Overall length	2022 mm (79.6 in)
Overall width	733 mm (28.9 in)
Overall height	1,095 mm (43.1 in)
Wheel base	1,285 mm (50.6 in)

WEIGHT

Dry weight	102 kg (225 lbs)
------------	------------------

CAPACITIES

Engine oil	After draining	0.9 L (0.9 US qt, 0.75 Imp qt)
	After disassembly	1.0 L (1.1 US qt, 0.91 Imp qt)
Fuel tank		8.0 L (2.11 US gal, 1.76 Imp gal)
Fuel tank reserve		1.5 L (0.39 US gal, 0.32 Imp gal)
Passenger capacity		Operator and one passenger
Maximum weight capacity		170 Kg (375 lbs)

ENGINE

Bore and stroke	50.0 x 55.6 mm (1.97x 2.18 in)
Compression ratio	9.9±0.2:1
Displacement	109.19 cm ³ (6.66 CU-in)
Spark plug	NGK CPR7EA9
Spark plug gap	0.8-0.9 mm (0.03-0.04 in)
Idle speed	1,400 ± 100 min ⁻¹ (rpm)
Valve clearance	Intake 0.10 (0.0039 in) Exhaust 0.15 (0.0059 in)

CHASSIS AND SUSPENSION

Caster	26 ^o .18'
Trail	93 mm (3.66 in)
Tyre size, front	80/100 - 18M/C 47P
Tyre size, rear	80/100 - 18M/C 54P
Suspension	Front Telescopic Fork Rear Twin
Turning radius	1.90 m

FUEL SYSTEM

Type	Carburetor
------	------------

POWER TRANSMISSION

Primary reduction		3.722
Gear ratio,	1st	3.181
	2nd	1.764
	3rd	1.190
	4th	0.916
Final reduction		2.928

ELECTRICAL

Battery	12V-3Ah/ MF - Maintenance Free
Generator	0.14 kW/5,000 min ⁻¹ (rpm)

LIGHTS

Headlight	12V 35/35W
Position light	12V 3W
Brake/Taillight	12V 21/5W
Turn signal light	12V-10W X 4
Turn signal indicator	12V-1.7W X 1
High beam indicator	12V-1.7W X 1
Neutral indicator	12V-1.7W X 1

FUSE

Main fuse	15A x 1
Other fuse	10A x 1

CATALYTIC CONVERTER

This vehicle is equipped with a catalytic converter.

The catalytic converter contains precious metals that serve as catalysts, promoting chemical reactions to convert the exhaust gases without affecting the metals.

The catalytic converter acts on HC, CO and NOx. A replacement unit must be an original Honda part or its equivalent.

The catalytic converter must operate at a high temperature for the chemical reactions to take place. It can set on fire any combustible materials that come near it. Park your vehicle away from high grasses, dry leaves or other flammables.

A defective catalytic converter contributes to air pollution, and can impair your engine's performance. Follow these guidelines to protect your vehicle catalytic converter.

- Always use unleaded petrol. Even a small amount of leaded petrol can contaminate the catalyst metals making the catalytic converter ineffective.
- Keep your engine tuned-up.
- Have your vehicle diagnosed and replaced if it is misfiring, backfiring, stalling or otherwise not running properly.

Warranty Policy

Honda Motorcycle & Scooter India (Pvt.) Ltd. (HMSI) gives the following warranty in respect of vehicle "**Dream Yuga**" manufactured by them.

Proper care and precaution has been taken to ensure the best quality in respect of the material and workmanship in manufacturing "**Dream Yuga**".

HMSI would repair or replace at its discretion, those part(s) found to have manufacturing defects during examination. This repair or replacement of part(s) would be done free of charge at their authorised workshop, within a warranty period of 24 months from the date of sale or until the vehicle has covered 32000 kms, whichever comes first.

Warranty claims in respect of proprietary parts like tyres and battery are warranted by their respective manufacturers and should be claimed on them directly by customer.

NOTE: Battery Warranty is applicable from 21 months from Date Of Charging at manufacturer or 18 Months from the Date Of Sale or 20000 Kms whichever is earlier.

In all such cases the decision of the respective manufacturer will be final and binding.

HMSI shall not be liable in any manner to replace them though their dealers will give full assistance in preferring such claims on their manufacturers.

HMSI undertake no liability in the matter of consequential loss or damage caused due to the failure of the parts. Delay, if any, at the repairing workshop in carrying out repair to vehicle shall not be a ground for extending the warranty period nor shall it give any right to the customer for claiming any compensation for damages.

HMSI reserves the right either to repair or replace the defective part.

Where a defective part can be replaced by part/s of alternative brand/s, which are normally used by HMSI in the course of manufacturing, HMSI reserves the right to carry out the replacement by a part or parts of any such alternative brands.

This warranty and any claim arising therefrom is subject to Gurgaon jurisdiction only.

No claim for exchange or repair can be considered unless the customer:

- a. Ensures that immediately upon discovery of the defect, he approaches any nearest authorised dealer of HMSI with the concerned vehicle and enables him to remove and dispatch the part/parts attributing to manufacturing defect to the company.
- b. Produces Owner's Manual in original, to enable that dealer to verify the details. It must be expressly understood that claims forwarded directly to us by the owner/customer will not be entertained at all and such defective part/parts thus forwarded by them will lie at our factory at their own risk, and this warranty shall not be enforceable.

Further this warranty is not applicable to:

1. Any "**Dream Yuga**" on which any free and paid services has not been carried out, as per schedule given in Owner's Manual.
2. Normal maintenance operations like valve adjustment, cleaning of fuel system, engine tune-up or such other adjustments.
3. HMSI does not warrant normal wear and tear items like Clutch Disc, Chain, Chain Sprocket, Wheel Rim (in case of misalignment and bent), Bushes, Fasteners, Shims, Washers and Electrical Items like Bulbs, Rubber and Plastic Components like Grommets,

O-Rings, Bellows as well as Packings, Gaskets, Oil Seals and Consumables like Fuel Filter, Air Cleaner Element, Engine Oil, Grease, Suspension Oil and other items as specified by HMSI.

4. Fasteners and clips which needs replacement during maintenance/service will not be covered under warranty.
5. If there is any damage to the painted surface due to industrial pollution or other extraneous factors.
6. Any damage resulting from unavoidable natural disaster i.e fire collision, earthquake, flood etc.
7. Any damage caused by exposure of the product to soot and smoke, chemical agents, bird-droppings, sea water, sea breeze, or other environmental phenomenon.
8. If there is any damage caused due to usage of improper oil/grease, non genuine parts.
9. For two-wheelers, which have been used for any commercial purposes as taxi etc.
10. For maintenance repairs required due to misuse while driving or due to adulteration of oil, petrol or due to bad road conditions.
11. Recommended fuel quality not used.
12. Parts of the vehicle that have been subjected to misuse, accident, negligent treatment or which have been used in conjunction with parts and an equipment not manufactured or recommended for use by HMSI if in the sole judgment of HMSI, such use prematurely affects the performance and reliability of the vehicle.
13. Parts of the vehicle that have been altered or modified or replaced in unauthorised manner, and which in the sole judgment of HMSI affect its performance and reliability.
14. The vehicle that has not been serviced by HMSI authorised dealer as per the service schedule or which have not been operated or maintained in accordance with instructions mentioned in the Owner's Manual.

15. The vehicles used for any competition or race and/or for attempting to set up any kind of record HMSI reserves the right to make any changes in design or to add any improvement on the vehicle at any time without incurring any obligations to install the same on a vehicle previously supplied and sold. Also the conditions of this warranty are subject to alteration without any notice.

This warranty is entirely written warranty given by HMSI for "**Dream Yuga**" and no other person, including the dealer or its or his agent or employee is authorised to extend or enlarge this warranty.

This warranty is given in lieu of and excludes every condition or warranty whether statutory or otherwise not herein expressly set out.

EMISSION WARRANTY

Subject to other terms of the warranty policy and other conditions and obligations laid down hereunder, the manufacturer certifies that the components liable to affect the emission of the gaseous pollutants in the vehicle in normal use despite the use to which it may be subjected, comply with provisions of rule 115(2) of the Central Motor Vehicle Rules, 1989 and further warrants that if on examination by a service center duly authorized by the manufacturer, the vehicle is discovered to be failing to meet the emission standard as specified in the said rule, the authorized service center shall take such corrective measures as may be necessary and shall at its sole discretion replace free of charge such components of emission control system as are specified in schedule.

A. Conditions

1. This warranty will be in addition to and run parallel to the product warranty given by the manufacturer and will apply to components as mentioned later. This warranty is applicable in Delhi, Mumbai, Kolkata and Chennai with effective from 1st July 2001. Other places when included will be covered under warranty accordingly.
2. The period of the vehicle's emission warranty will be determined starting from the date of the vehicle sale. The period of time and kilometers that are covered under the provisions of warranty may vary but should not be less than the minimum warranty period based on the vehicle category.

For a two-wheeler the emission warranty period is 30,000 kms or 3 years whichever is earlier.

3. Warranty claim for the components under Emission warranty as per annexure-II will be admitted, for a prima facie examination, in the event of failure of the vehicle to meet the emission standard as specified in sub-rule (2) of Rule No 115 of the Central Motor vehicle Rules.
4. The warranty claim will be accepted only after the examinations carried out by Authorized Service Centers leads to a firm conclusion that none of the original settings have been tampered with and that the components as mentioned in annexure-II has/have a manufacturing defect, and/or, that the vehicle is unable to meet the in-use emission standard, in spite of the vehicle being maintained and used in accordance with the instructions in the owner's manual.

5. The methods of examination to determine the warrantable condition of the components will be at the sole discretion of manufacturers and or their Authorized service centers and results of such examination will be final and binding. If, on examination, a warrantable condition is not established, the manufacturers will have to charge all, or part, of the cost of such examination.
6. In case of a vehicle in which the components covered under Emission warranty, the manufacturer will replace, at Authorized centers free of charge, the components which are covered as mentioned in Annexure-II, but the consumables as mentioned in Owner's Manual shall be charged as per actuals.
7. In case of a vehicle in which the components covered under Emission warranty or the associated parts are not independently replaceable on account of their being integral parts of a complete assembly, the manufacturer will have the sole discretion to replace either the entire assembly or by using some of the parts of the system through suitable repairs or modifications.
8. Any consequential repairs or replacement of parts which may be found necessary to establish compliance to in-use emission standards, in addition to replacement of the parts covered under emission warranty, will not be made free of cost unless such parts are also found to be in a warrantable condition within the scope and limit of the product warranty. The consumables shall be charged as per actuals during such repairs or replacement of parts.
9. All the parts removed for replacement under warranty will be the property of the manufacturer.
10. The manufacturer will not be responsible for the cost of transportation of the vehicle to the nearest Authorized

Service center or any loss due to non-availability of the vehicle during the period of lodging of a warranty claim and examination by the manufacturer and repairs.

11. The manufacturer will not be responsible for any penalties that may be charged by statutory authorities on account of failure to comply with the in use emission standards.
12. Emission warranty will be applicable irrespective of the change of ownership of the vehicle provided all the conditions as laid down in this document are met from the date of original sale of the vehicle.
13. The emission warranty will be applicable only if:
 - a. Observes all the important instructions and any other precautions listed in the Owner's Manual for use of the vehicle.
 - b. Under all circumstances uses lubricants and fuel as recommended by manufacturer.
 - c. Regularly obtains and carries out maintenance in accordance with the manufacturers guidelines and enters the details in the Logbook.
 - d. Immediately approaches the nearest authorized service center upon discovery of failure to comply with the in use emission standards in spite of having maintained and used the vehicle in accordance with the instructions in the Owner's Manual and having carried out such repairs and adjustments as may be required with a view to establish such compliance.
 - e. Produces the 'Pollution Under Control' certificate valid for the period immediately preceding the test during which the failure is discovered, the test having been

carried out either for obtaining a new certificate, or pursuant upon being directed by an officer as referred to in sub-rule(2) of Rule 116 of the Central Motor Vehicle Rules.

- f. Produces the Owner's Manual and Log book for verification details.
 - g. Produces receipts covering maintenance of the vehicle as specified in the Owner's Manual from the date of original purchase of the vehicle.
 - h. Produces valid certificate of insurance and RTO registration.
14. Conditions under which warranty is not applicable:
A valid 'Pollution Under Control' certificate as described in customer obligation D(6) above is not produced.

A vehicle which is not serviced by Authorized service center as per the service schedule described in the maintenance chart given in the Owner's Manual.

A vehicle, which has been subjected to abnormal use, abuse, neglect and improper maintenance or has met with an accident. Use of replacement parts not specified and approved by the manufacturer.

A vehicle, or parts thereof, which has been altered, tampered with or modified or replaced in an unauthorized manner.

A vehicle on which the odometer is not functioning or the odometer has been changed/tampered with so that the actual mileage cannot be readily determined.

A vehicle which has been used for competitions, races, rallies or for the purpose of establishing records

Examination by the manufacturers or his Authorized Service Centers of the vehicle shows that any of the conditions stipulated in the Owner's Manual with regard to use and maintenance have been violated.

A vehicle, which has been run on, adulterated fuel, leaded fuel or lubricant or fuel/lubricants other than those specified by the manufacturer in the Owner's Manual with regard to use and maintenance have been violated.

SCOPE AND LIMITS

1. This emission warranty is in addition to product warranty and shall run parallel to the product warranty for the vehicle as per the scope and limit described in the Owner's Manual and all conditions

described there in will apply in addition to those exclusively stipulated in this warranty.

2. The emission warranty covers only compliance with the emission standard as specified in the sub rule (2) of rule 115 of CMVR. It does not cover any other performance of these parts or routine test and consequent maintenance or adjustments to establish compliance to the in use emission standard as applicable to the state, in which the vehicle is registered and is in use.

The parts, which are covered under emission warranty, are carburetor and internal parts, intake manifold, distributor and internal parts, ignition coil, muffler etc.

NOTE: The emission warranty is applicable only when a customer enters into emission warranty contract.