



Very Low Power 8-Bit 32 kHz RTC with Digital Trimming, User RAM and High Level Integration

Features

- Digital trimming and temperature compensation facilities
- Can be synchronized to 50 Hz or nearest s/min
- 50 ns access time with 50 pF load capacitance
- Standby on power down typically 1.2 μ A
- Universal interface compatible with both Intel and Motorola
- Simple 8 bit interface with no delays or busy flags
- 16 bytes of user RAM
- Power fail input disables during power up / down or reset
- Bus can be tri-state in power fail mode
- Wide voltage range, 2.0 V to 5.5 V
- 12 or 24 hour data formats
- Time to 1/100 of a second
- Leap year correction and week number calculation
- Alarm and timer interrupts
- Programmable interrupts: 10 ms, 100 ms, s or min
- Sleep mode capability
- Alarm programmable up to one month
- Timer measures elapsed time up to 24 hours
- Temperature range -40 to +85 $^{\circ}$ C
- Packages DIP20 and SO20

Description

The A3024 is a low power CMOS real time clock. Standby current is typically 1.2 μ A and the access time is 50 ns. The interface is 8 bits with multiplexed address and data bus. Multiplexing of address and data is handled by the input line \bar{A}/D . There are no busy flags in the A3024, internal time update cycles are invisible to the user's software. Time data can be read from the A3024 in 12 or 24 hour data formats. An external signal puts the A3024 in standby mode. Even in standby, the A3024 pulls the \overline{IRQ} pin active low on an internal alarm interrupt. Calendar functions include leap year correction and week number calculation. Time precision can be achieved by digital trimming. The A3024 can be synchronized to an external 50 Hz signal or to the nearest second or minute.

Applications

- Industrial controllers
- Alarm systems with periodic wake up
- PABX and telephone systems
- Point of sale terminals
- Automotive electronics

Typical Operating Configuration

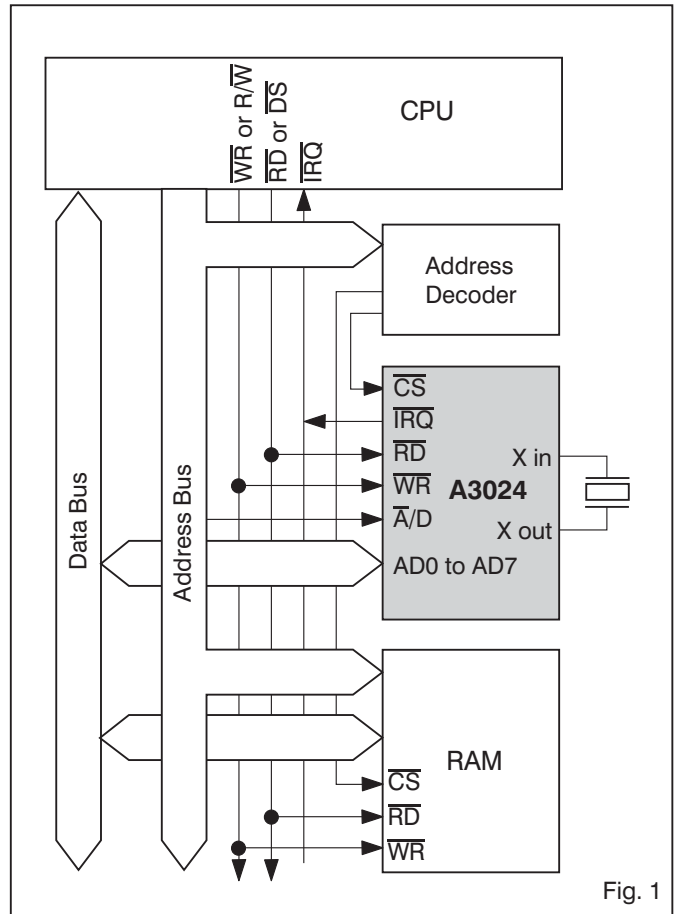

Fig. 1

Pin Assignment

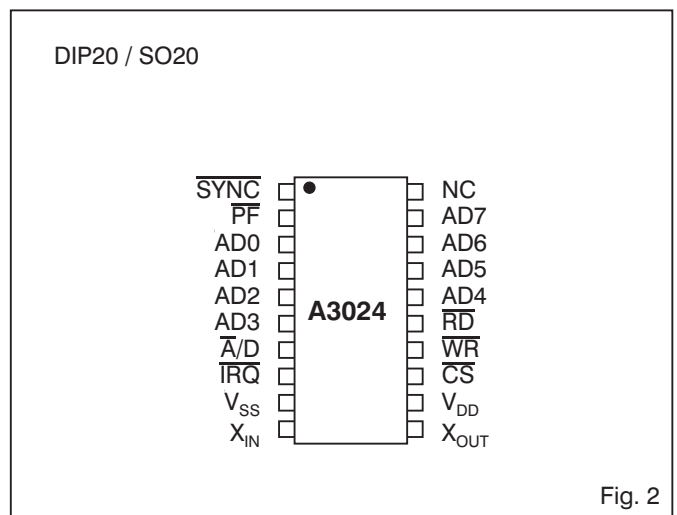

Fig. 2



Absolute Maximum Ratings

Parameter	Symbol	Conditions
Maximum voltage at V_{DD}	V_{DDmax}	$V_{SS} + 7.0V$
Max. voltage at remaining pins	V_{max}	$V_{DD} + 0.3V$
Min. voltage on all pins	V_{min}	$V_{SS} - 0.3V$
Maximum storage temperature	T_{STOmax}	+125°C
Minimum storage temperature	T_{STOmin}	-55°C
Maximum electrostatic discharge to MIL-STD-883C method 3015	V_{Smax}	1000V
Maximum soldering conditions	T_{Smax}	250°C x 10s

Table 1

Stresses above these listed maximum ratings may cause permanent damage to the device. Exposure beyond specified operating conditions may affect device reliability or cause malfunction.

Handling Procedures

This device has built-in protection against high static voltages

Electrical Characteristics

$V_{DD} = 5.0V \pm 10\%$, $V_{SS} = 0V$, $T_A = -40$ to $+85^\circ C$, unless otherwise specified

Parameter	Symbol	Test Conditions	Min.	Typ.	Max.	Units
Standby current ¹⁾	I_{DD}	$V_{DD} = 3V, \overline{PF} = 0$ $V_{DD} = 5V, \overline{PF} = 0$		1.2 2	10 15	μA μA
Dynamic current ²⁾	I_{DD}	$\overline{CS} = 4MHz, \overline{RD} = V_{SS},$ $\overline{WR} = V_{DD}$			1.5	mA
IRQ (open drain)						
Output low voltage	V_{OL}	$I_{OL} = 8mA$			0.4	V
Output low voltage	V_{OL}	$I_{OH} = 1mA, V_{DD} = 2V$			0.4	V
Inputs and Outputs						
Input logic low	V_{IL}	$T_A = +25^\circ C$			$0.2 \cdot V_{DD}$	V
Input logic high	V_{IH}	$T_A = +25^\circ C$	$0.8 \cdot V_{DD}$			V
Output logic low	V_{OL}	$I_{OL} = 6mA$			0.4	V
Output logic high	V_{OH}	$I_{OH} = 6mA$	2.4			V
\overline{PF} activation voltage	V_{PFL}			$0.5 \cdot V_{DD}$		V
\overline{PF} hysteresis	V_H	$T_A = +25^\circ C$		100		mV
Pullup on \overline{SYNC}	I_{LS}	$V_{ILS} = 0.8V$	20			μA
Input leakage	I_{IN}	$V_{SS} < V_{IN} < V_{DD}$		10	1000	nA
Output tri-state leakage	I_{TS}	$\overline{CS} = 1$		10	1000	nA
Oscillator Characteristics						
Starting voltage	V_{STA}	$T_A \geq +25^\circ C$	2			V
	V_{STA}			2.5		V
Start-up time	T_{STA}			1		s
Frequency Characteristics						
Frequency tolerance	$\Delta f/f$	$T_A = +25^\circ C$ addr. 10 hex = 00 hex		210 ⁴⁾	251	ppm
Frequency stability	f_{sta}	$2.0 \leq V_{DD} \leq 5.5V$ ³⁾		1	5	ppm/V
Temperature stability	t_{sta}	addr. 10 hex = 00 hex		see Fig. 5		ppm

Table 2

Table 3

¹⁾ With $\overline{PFO} = 0$ (V_{SS}) all I/O pads can be tri-state, tested.

With $\overline{PFO} = 1$ (V_{DD}), $\overline{CS} = 1$ (V_{DD}) and all other I/O pads fixed to V_{DD} or to V_{SS} : same standby current, not tested.

²⁾ All other inputs to V_{DD} and all outputs open.

³⁾ At a given temperature.

⁴⁾ See Fig. 4

or electric fields; however, it is advised that normal precautions must be taken as for any other CMOS component. Unless otherwise specified, proper operation can only occur when all terminal voltages are kept within the supply voltage range. Unused inputs must always be tied to a defined logic voltage level.

Operating Conditions

Parameter	Symbol	Min.	Typ.	Max.	Units
Operating temperature	T_A	-40		+85	°C
Logic supply voltage	V_{DD}	2.0	5.0	5.5	V
Supply voltage dv/dt (power-up & down)	dv/dt			6	V/ μs
Decoupling capacitor			100		nF
Crystal Characteristics					
Frequency	f		32.768		kHz
Load Capacitance	C_L	7	8.2	12.5	pF
Series resistance	R_s		35	50	k Ω



Typical Standby Current at $V_{DD} = 5\text{ V}$

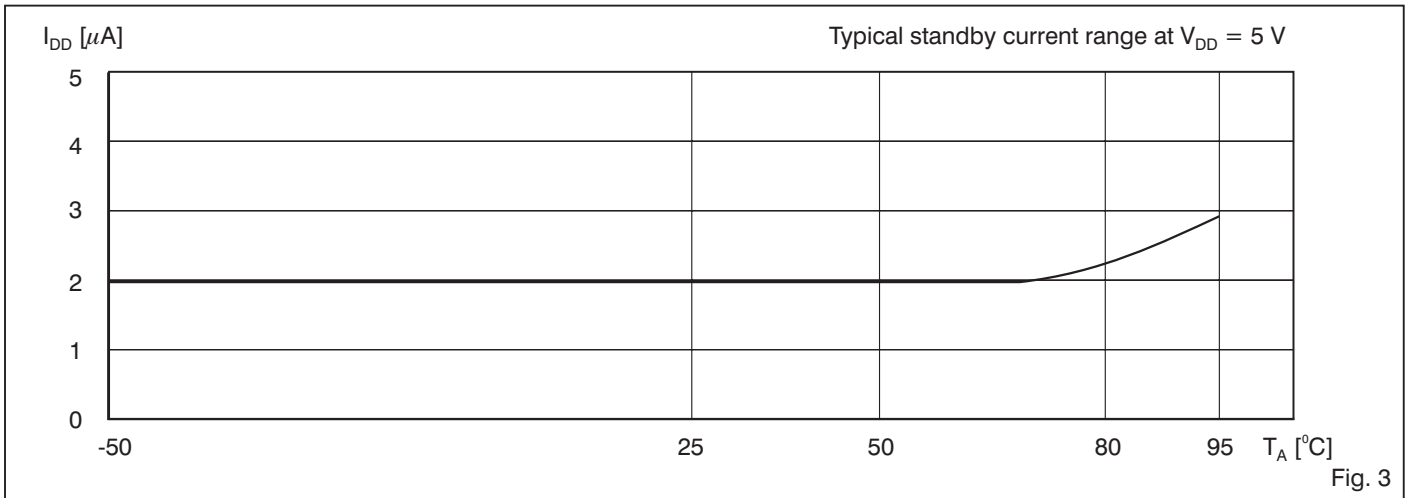

Typical Frequency on \overline{IRQ}

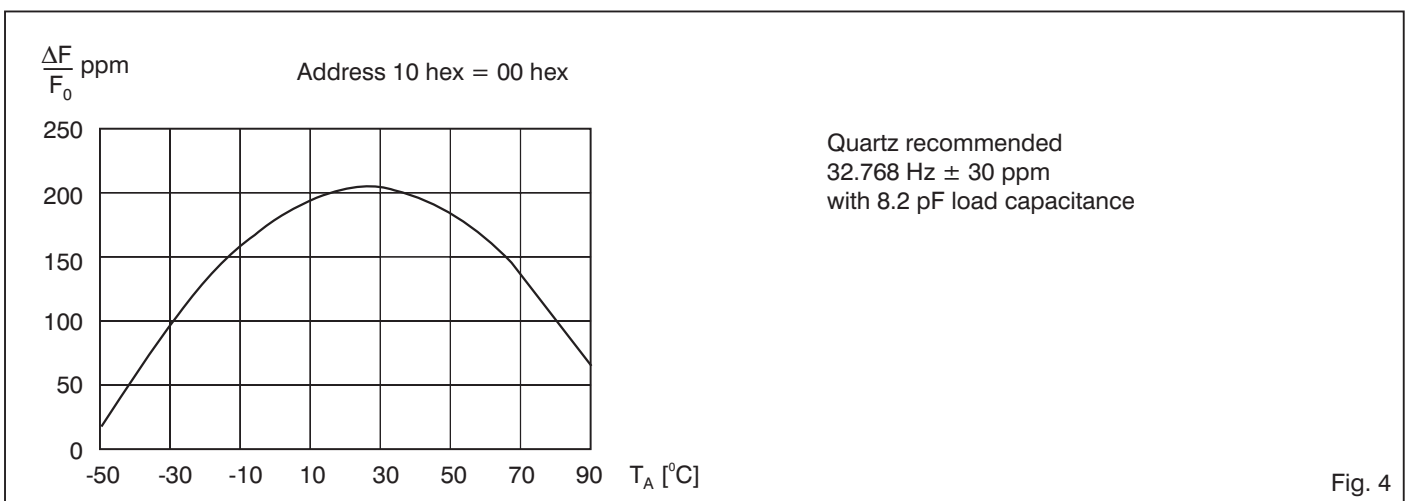

Characteristic of a Quartz

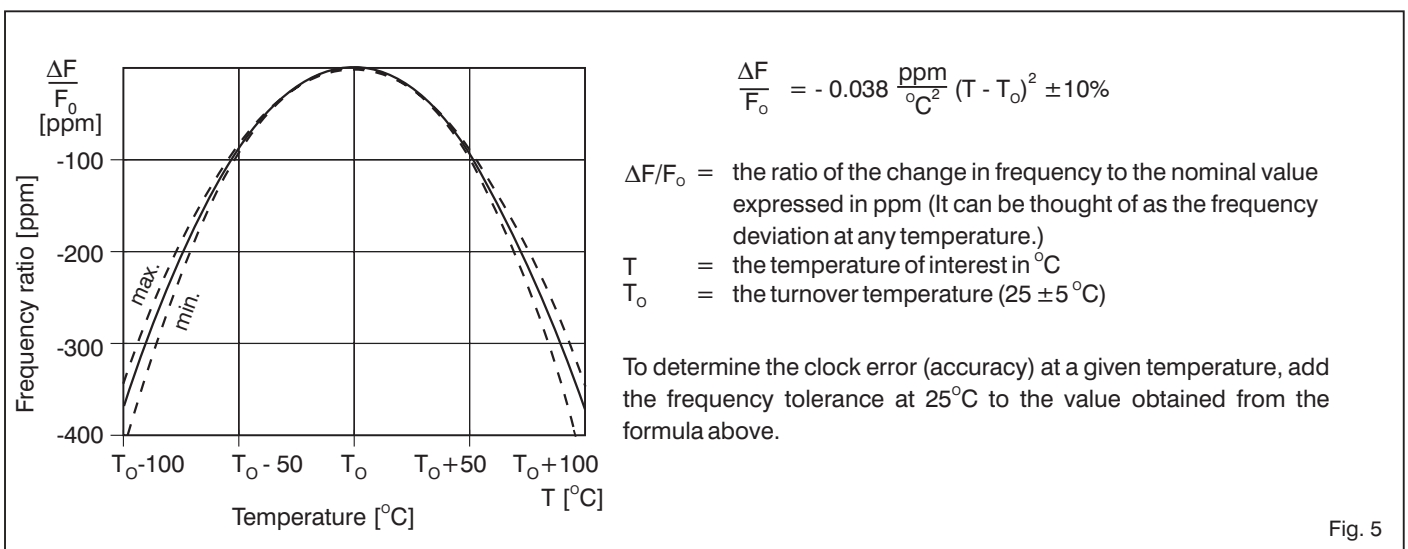



Timing Characteristics

$V_{DD} = 5.0 \pm 10\%$, $V_{SS} = 0$ V, and $T_A = -40$ to $+85$ °C

Parameter	Symbol	Test Conditions	Min.	Typ.	Max.	Units
Chip select duration, write cycle	t_{CS}		50			ns
Write pulse duration	t_{WR}		50			ns
Time between two transfers	t_W		100			ns
RAM access time ¹⁾	t_{ACC}	$C_{LOAD} = 50$ pF		50	60	ns
Data valid to Hi-impedance ²⁾	t_{DF}		10	30	40	ns
Write data settle time ³⁾	t_{DW}		50			ns
Data hold time ⁴⁾	t_{DH}		10			ns
Advance write time	t_{ADW}		10			ns
PF response delay	t_{PF}				100	ns
Rise time (all timing waveform signals)	t_R				200	ns
Fall time (all timing waveform signals)	t_F				200	ns
\overline{CS} delay after $\overline{A/D}$ ⁵⁾	$t_{\overline{A}/Ds}$		5			ns
\overline{CS} delay to $\overline{A/D}$	$t_{\overline{A}/Dt}$		10			ns

Table 4

¹⁾ t_{ACC} starts from \overline{RD} (\overline{DS}) or \overline{CS} , whichever activates last

Typically, $t_{ACC} = 5 + 0.9 C_{EXT}$ in ns; where C_{EXT} (external parasitic capacitance) is in pF

²⁾ t_{DF} starts from \overline{RD} (\overline{DS}) or \overline{CS} , whichever deactivates first

³⁾ t_{DW} ends at \overline{WR} (R/\overline{W}) or \overline{CS} , whichever deactivates first

⁴⁾ t_{DH} starts from \overline{WR} (R/\overline{W}) or \overline{CS} , whichever deactivates first

⁵⁾ $\overline{A/D}$ must come before a \overline{CS} and \overline{RD} or a \overline{CS} and \overline{WR} combination. The user has to guarantee this.

Timing Waveforms

Read Timing for Intel (\overline{RD} and \overline{WR} pulse) and Motorola (\overline{DS} or \overline{RD} pin tied to \overline{CS} , and R/\overline{W})

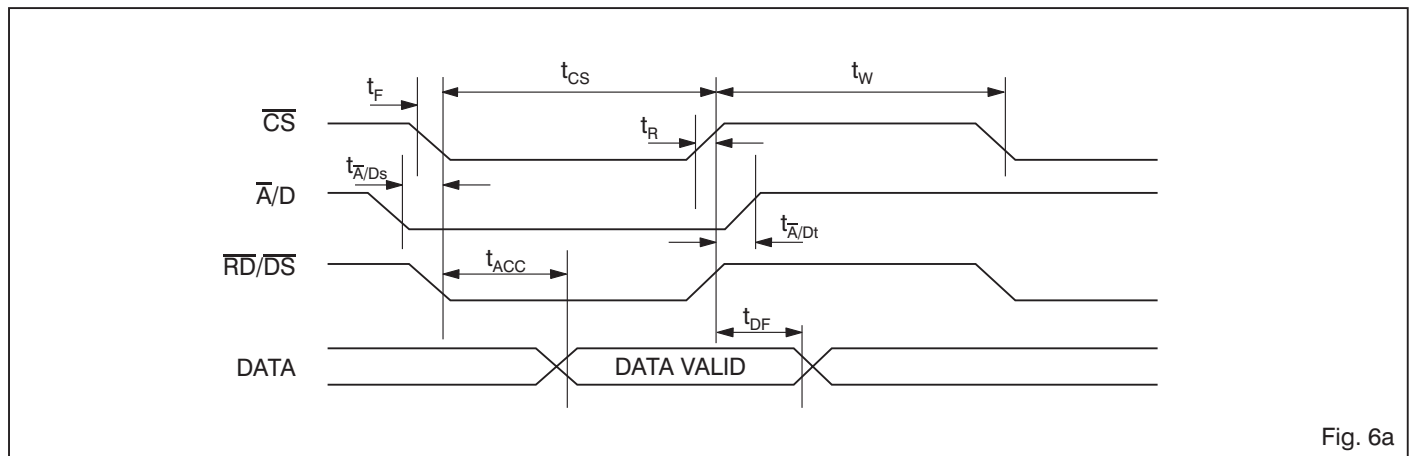

Fig. 6a



Intel Interface Write Timing

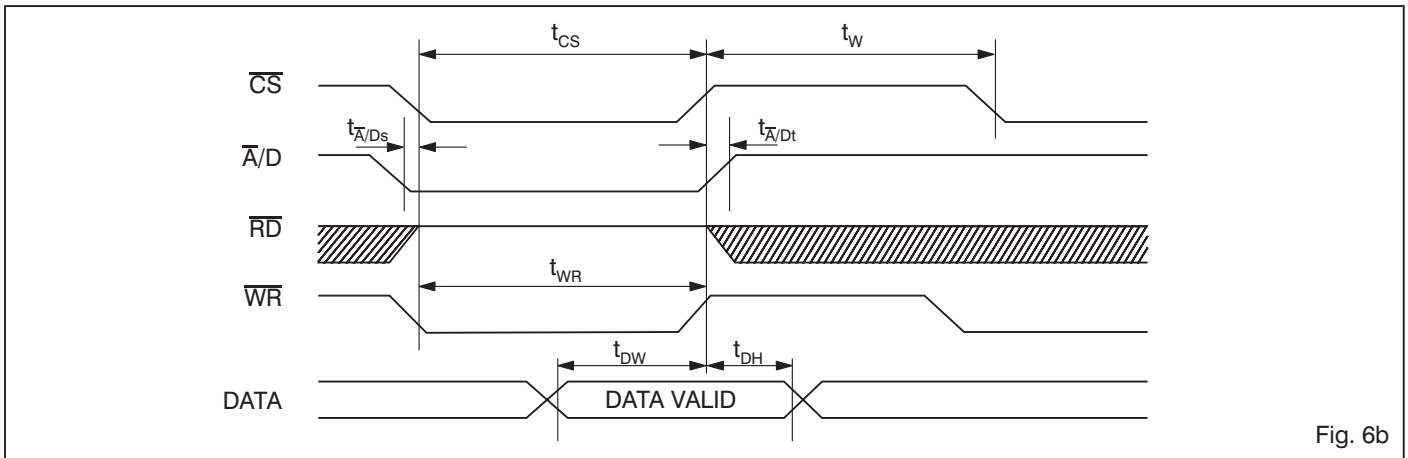

Fig. 6b

Write

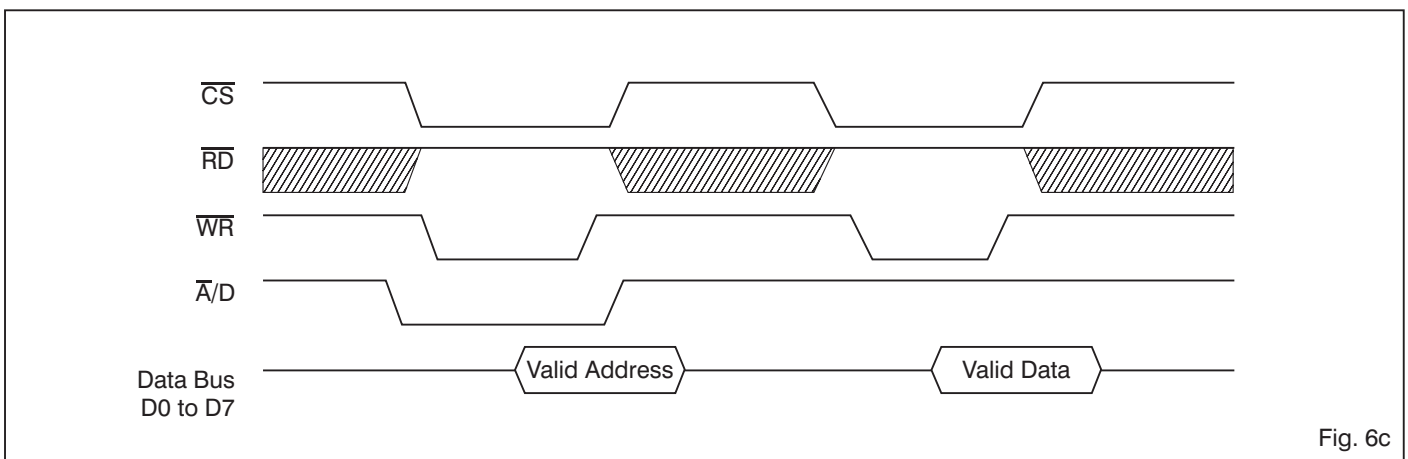

Fig. 6c

Read

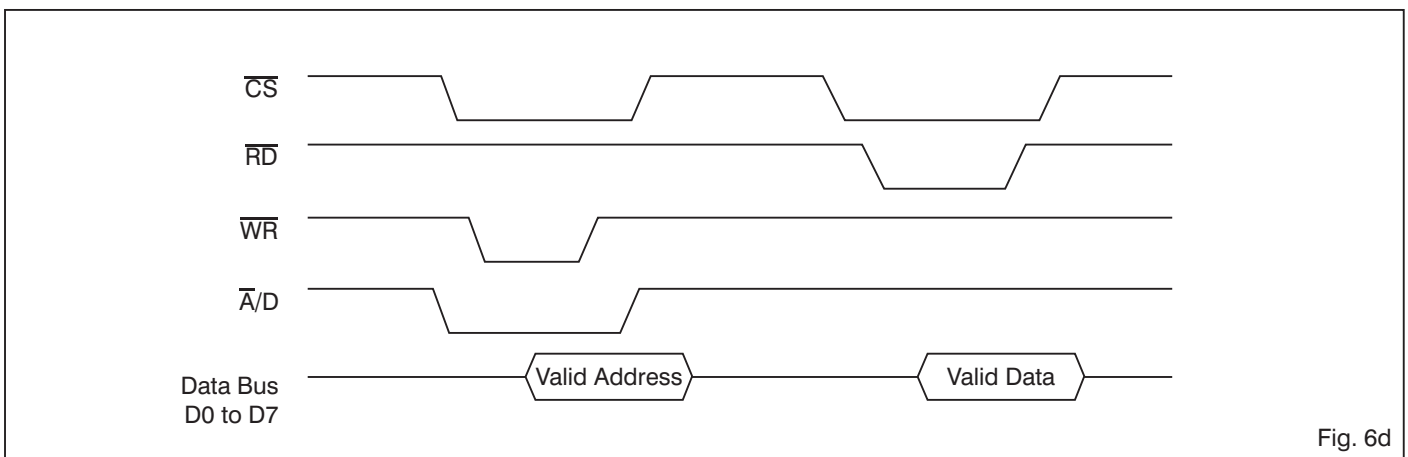

Fig. 6d



Motorola Interface

Motorola Write

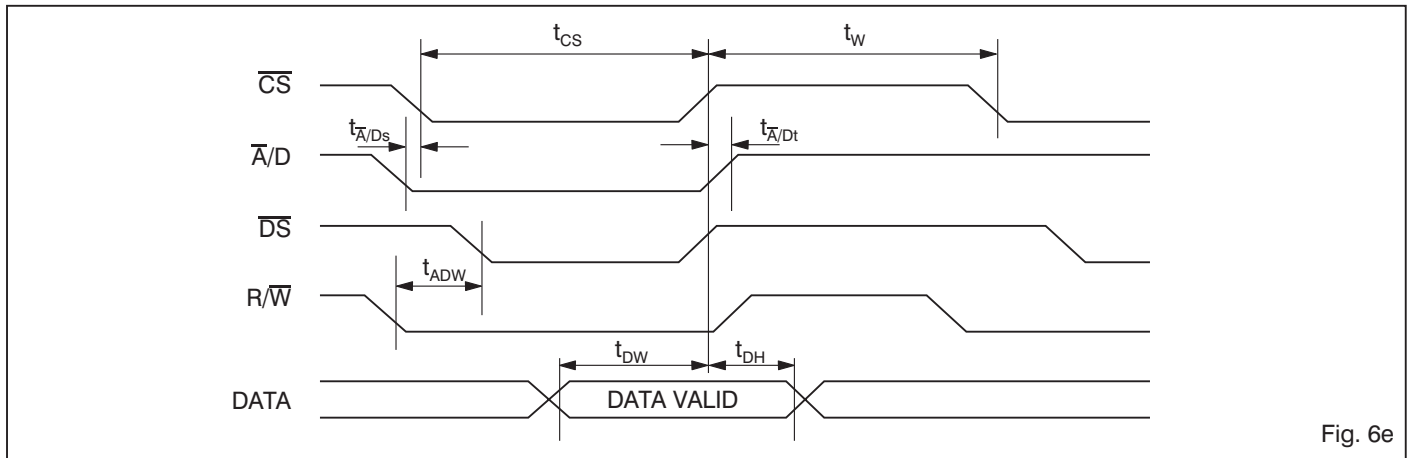

Fig. 6e

Write

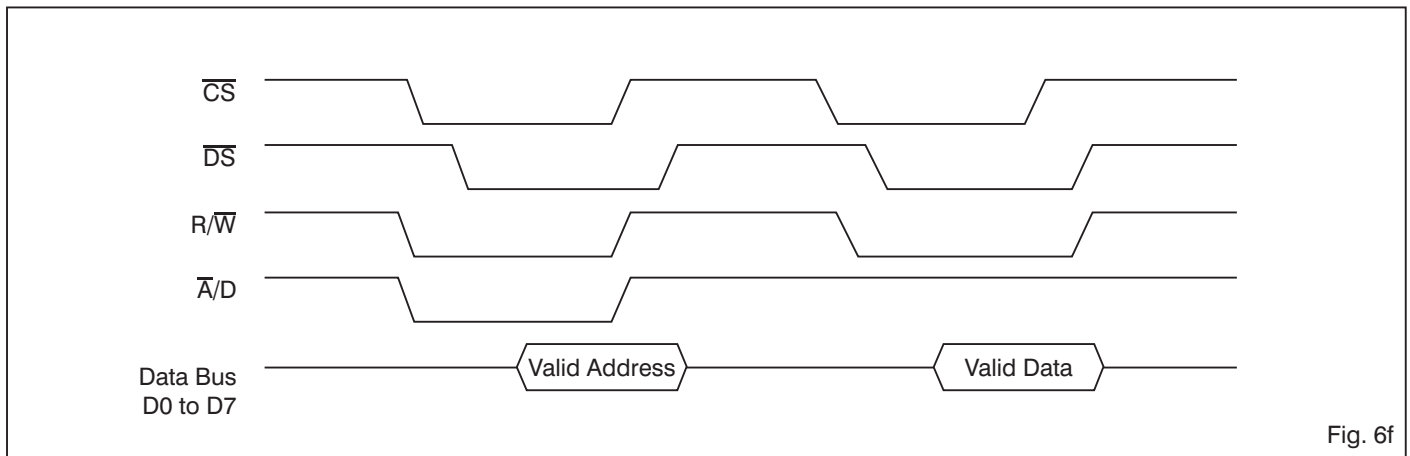

Fig. 6f

Read

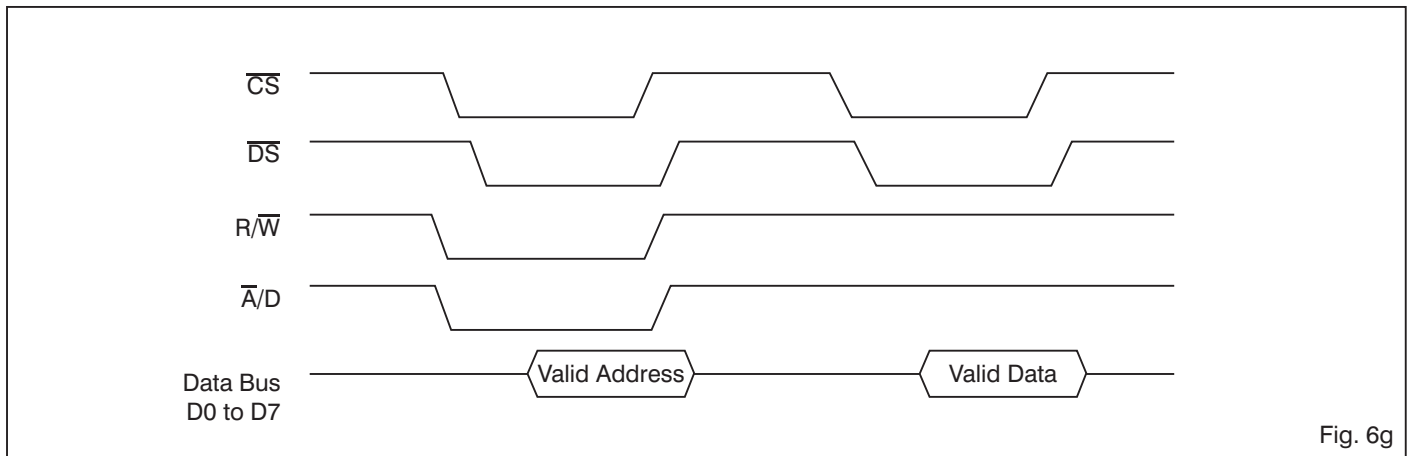

Fig. 6g



General Block Diagram

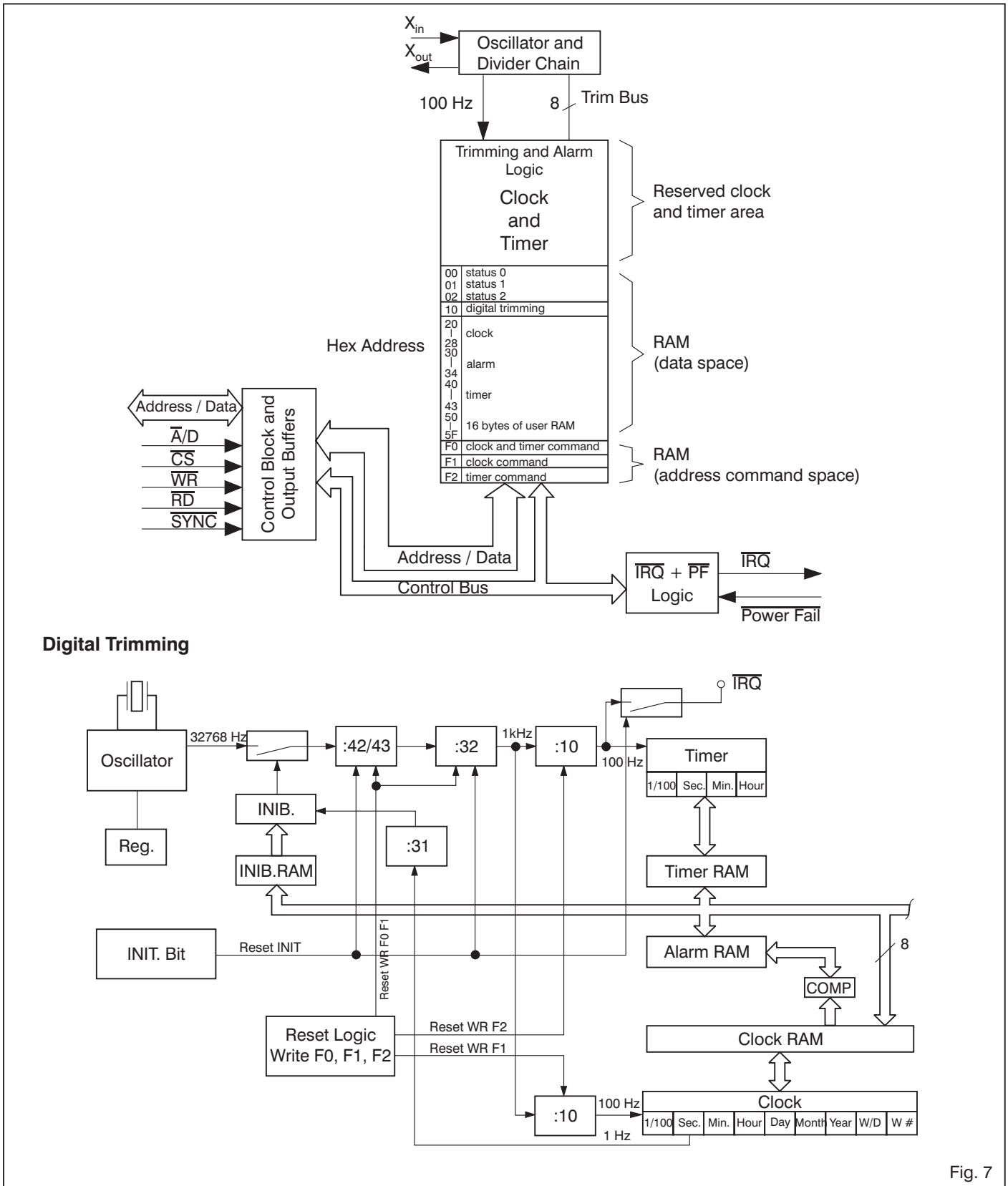

Fig. 7



Pin Description

DIP20 and SO20 Packages

Pin	Name	Description	
1	$\overline{\text{SYNC}}$	Time synchronization	I
2	$\overline{\text{PF}}$	Power fail	I
3	AD0	Bit 0 from MUX address / data bus	I/O
4	AD1	Bit 1 from MUX address / data bus	I/O
5	AD2	Bit 2 from MUX address / data bus	I/O
6	AD3	Bit 3 from MUX address / data bus	I/O
7	$\overline{\text{A/D}}$	Address / data decode	I
8	$\overline{\text{IRQ}}$	Interrupt request	O
9	V_{SS}	Supply ground (substrate)	GND
10	X_{IN}	Oscillator input	I
11	X_{OUT}	Oscillator output	O
12	V_{DD}	Positive supply terminal	PWR
13	$\overline{\text{CS}}$	Chip select	I
14	$\overline{\text{WR}}$	WR (Intel) or R/W (Motorola)	I
15	$\overline{\text{RD}}$	RD (Intel) or DS (Motorola)	I
16	AD4	Bit 4 from MUX address / data bus	I/O
17	AD5	Bit 5 from MUX address / data bus	I/O
18	AD6	Bit 6 from MUX address / data bus	I/O
19	AD7	Bit 7 from MUX address / data bus	I/O
20	NC	No connection	-

Table 5

Functional Description

Power Supply, Data Retention and Standby

The A3024 is put in standby mode by activating the $\overline{\text{PF}}$ input. When pulled logic low, $\overline{\text{PF}}$ will disable the input lines, and immediately take to high impedance the lines AD 0-7. Input states must be under control whenever $\overline{\text{PF}}$ is deactivated. If no specific power fail signal can be provided, $\overline{\text{PF}}$ can be tied to the system $\overline{\text{RESET}}$. Even in standby the interrupt request pin $\overline{\text{IRQ}}$ will pull to ground upon an unmasked alarm interrupt occurring.

Initialisation

When power is first applied to the A3024 all registers have a random value.

To initialise the A3024, software must first write a 1 to the

initialisation bit (addr. 2 bit 4) and then a 0. This sets the Frequency Tuning bit and clears all other status bits.

The time and date parameters should then be loaded into the RAM (addr. 20 to 28 hex) and then transferred to the reserved clock area using the clock command followed by a write.

The digital trimming register must then be initialised by writing 210 (D2 hex) to it, if Frequency Tuning is not required. After having written a value to the digital trimming register the frequency tuning mode bit can be cleared.

RAM Configuration

The RAM area of the A 3024 has a reserved clock and time area, a data space, user RAM and an address command space (see Table 9 or Fig. 7). The reserved clock and timer area is not directly accessible to the user, it is used for internal time keeping and contains the current time and date plus the timer parameters.

Data Space

All locations in the data space are Read/Write. The data space is directly accessible to the user and is divided into five areas :

Status Registers - three registers used for status and control data for the device (see Tables 6, 7 and 8).

Digital Trimming Register - a special function described under "Frequency Tuning".

Time and Date Registers - 9 time and date locations which are loaded with, either the current time and date parameters from the reserved clock area or the time and date parameters to be transferred to the reserved clock area.

Alarm Registers - 5 locations used for setting the alarm parameters.

Timer Registers - 4 locations which are loaded with either the timer parameters from the reserved timer area or the timer parameters to be transferred to the reserved time area.

User RAM

The A3024 has 16 bytes of general purpose RAM available for the users applications. This RAM block is located at addresses 50 to 5F hex and is maintained even in the standby mode ($\overline{\text{PF}}$ active). The commands, or the time set lock bit, have no effect on the user RAM block. Reading or writing to the user RAM is similar to reading or writing to any system RAM address.



Status Words

Status 0 - Address 00 Hex							
7	6	5	4	3	2	1	0
Read / Write bits							
0 - disabled / 24 hour							
1 - enabled / 12 hour							
frequency tuning mode							
pulse enable / disable							
alarm enable / disable							
timer enable / disable							
24 hour / 12 hour ¹⁾							
time set lock							
test bit 0							
test bit 1							

Table 6

Status 1 - Address 01 Hex							
7	6	5	4	3	2	1	0
Read / Write bits							
0 - masked / no event							
1 - unmasked / event							
pulse mask							
alarm mask							
timer mask							
reserved							
pulse flag							
alarm flag							
timer flag							
reserved							

Table 7

Status 2 - Address 02 Hex							
7	6	5	4	3	2	1	0
Read / Write bits							
0 - disabled							
1 - enabled							
pulse every 10 ms							
pulse every 100 ms							
pulse every second							
pulse every minute							
initialisation bit							
SYNC 50 Hz							
SYNC second							
SYNC minute							

Table 8

¹⁾ The MSB (bit 7) of the hours byte (addr. 23 hex for the clock and 33 hex for the alarm) are used as AM/PM indicators in the 12 hour time data format and reading of the hours byte must be preceded by masking of the AM/PM bit. A set AM/PM bit indicates PM. In the 24 hour time data format the bit will always be zero.

²⁾ The alarm hours, addr. 33 hex, must always be rewritten after a change between 12 and 24 hour modes.

Address Command Space

This space contains the three commands used for carrying out the transfers between the Time and Date Register and / or the Timer Registers and the reserved clock and timer area.

RAM Map

Address		Parameter	Range
Dec	Hex		
Data Space			
Status			
00	00	status 0	
01	01	status 1	
02	02	status 2	
Special purpose			
16	10	digital trimming	0-255
Clock			
32	20	1/100 second	00-99
33	21	seconds	00-59
34	22	minutes	00-59
35	23	hours ¹⁾	00-23
36	24	date	01-31
37	25	month	01-12
38	26	year	00-99
39	27	week day	01-07
40	28	week number	00-53
Alarm			
48	30	1/100 second	00-99
49	31	seconds	00-59
50	32	minutes	00-59
51	33	hours ^{1) 2)}	00-23
52	34	date	01-31
Timer			
64	40	1/100 second	00-99
65	41	seconds	00-59
66	42	minutes	00-59
67	43	hours	00-23
User RAM			
80	50	user RAM, byte 0	
81	51	user RAM, byte 1	
82	52	user RAM, byte 2	
83	53	user RAM, byte 3	
84	54	user RAM, byte 4	
85	55	user RAM, byte 5	
86	56	user RAM, byte 6	
87	57	user RAM, byte 7	
88	58	user RAM, byte 8	
89	59	user RAM, byte 9	
90	5A	user RAM, byte 10	
91	5B	user RAM, byte 11	
92	5C	user RAM, byte 12	
93	5D	user RAM, byte 13	
94	5E	user RAM, byte 14	
95	5F	user RAM, byte 15	
Address Comand Space			
240	F0	clock and timer transfer	
241	F1	clock transfer	
242	F2	timer transfer	

Table 9



Communication

Data transfer is in 8 bit parallel form. All time data is in packed BCD format with tens data on lines AD 7 - 4 and units on lines AD 3 - 0. To access information within the RAM (see Fig. 7) first write the RAM address, then read or write from or to this location. Fig 8 shows the two steps needed.

The lines AD 0 - 7 will be treated as an address when pin \overline{A}/D is low, and as data when \overline{A}/D is high. Pin \overline{A}/D must not change state during any single read or write access. One line of the address bus (e.g. A0) can be used to implement the \overline{A}/D signal (see "Typical Operating Configuration", Fig. 1). Until a new address is written, data accesses (\overline{A}/D high) will always be to the same RAM address.

Communication Sequence

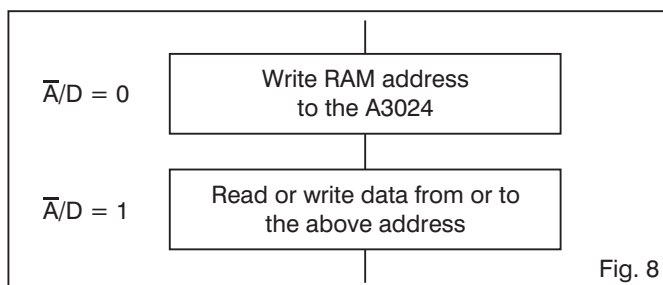

Fig. 8

Access Considerations

The communication sequence shown in Fig. 8 is re-entrant. When the address is written to the A3024 (ie. first step of the communication sequence) it is stored in an internal address latch. Software can read the internal address latch at any time by holding the \overline{A}/D line low during a read from the A3024. So, for example, an interrupt routine can read the address latch and push it onto a stack, popping it when finished to restore the A3024.

NB. Alarm and timer interrupt routines can reprogram the alarm and timer without it being necessary to read or reprogram the clock.

Commands

The commands allow software to transfer the clock and timer parameters in a sequence (eg. seconds, minutes, hours, etc.) without any danger of an internal time update with carry over corrupting the data. They also avoid delaying internal time updates while using the A3024, as updates occurring in the reserved clock and timer area are invisible to software. Software writes or reads parameters to or from the RAM only.

There are three commands that occupy the command address space in the RAM. The function of these commands is to transfer data from the reserved clock and timer area to the RAM or to transfer data in the opposite direction, from the RAM to the

reserved clock and timer area.

The commands take place in two steps as do all other communications. The command address is sent with \overline{A}/D low. This is followed by either a read (\overline{RD}) or a write (\overline{WR}), with \overline{A}/D high, to determine the direction of the transfer. If the second step is a read then the data is transferred from the reserved clock and timer area to the RAM and if the second step is a write then the data that has already been loaded into the RAM clock and/or timer locations is transferred to the reserved clock and/or timer area.

Clock and Calendar

The time and date locations in RAM (see Table 9) provide access to the 1/100 seconds, seconds, minutes, hours, date, month, year, week day, and week number. These parameters have the ranges indicated in Table 9. The A3024 may be programmed for 12 or 24 hour time format (see section "12/24 Data Format"). If a parameter is found to be out of range, it will be cleared when the units value on its being next incremented is equal to or greater than 9 eg. B2 will be set to 00 after the units have incremented to 9 (ie. B9 to 00). The device incorporates leap year correction and week number calculation at the beginning of a year. If the first day of the year is day 05, 06 or 07 of the week, then it is given a zero week number, otherwise it becomes week one. Week days are numbered from 1 to 7 with Monday as day 1.

Reading of the current time and date must be preceded by a clock command. The time and date from the last clock command is held unchanged in RAM.

When transferring data to the reserved clock and timer area remember to clear the time set lock bit first.

Timer

The timer can be used either for counting elapsed time, or for giving an interrupt (\overline{IRQ}) on being incremented from 23:59:59:99 to 00:00:00:00. The timer counts up with a resolution of 1/100 second in the timer reserved areas. The timer enable / disable bit (addr. 00 hex, bit 3) must be set by software to allow the timer to be incremented. The timer is incremented in the reserved timer area, every internal time update (10 ms). The timer flag (addr. 01 hex, bit 6) is set when the timer rolls over from 23:59:59:99 to 00:00:00:00 and the \overline{IRQ} becomes active if the timer mask bit (addr. 01, bit 2) is set. The \overline{IRQ} will remain active until software acknowledges the interrupt by clearing the timer flag. The timer is incremented in the standby mode, however it will not cause \overline{IRQ} to become active until power (V_{DD}) has been restored.

Note: The user should ensure that a time lapse of at least 60 microseconds exists between the falling edge of the \overline{IRQ} and the clearing of the timer flag.



Reading the Clock

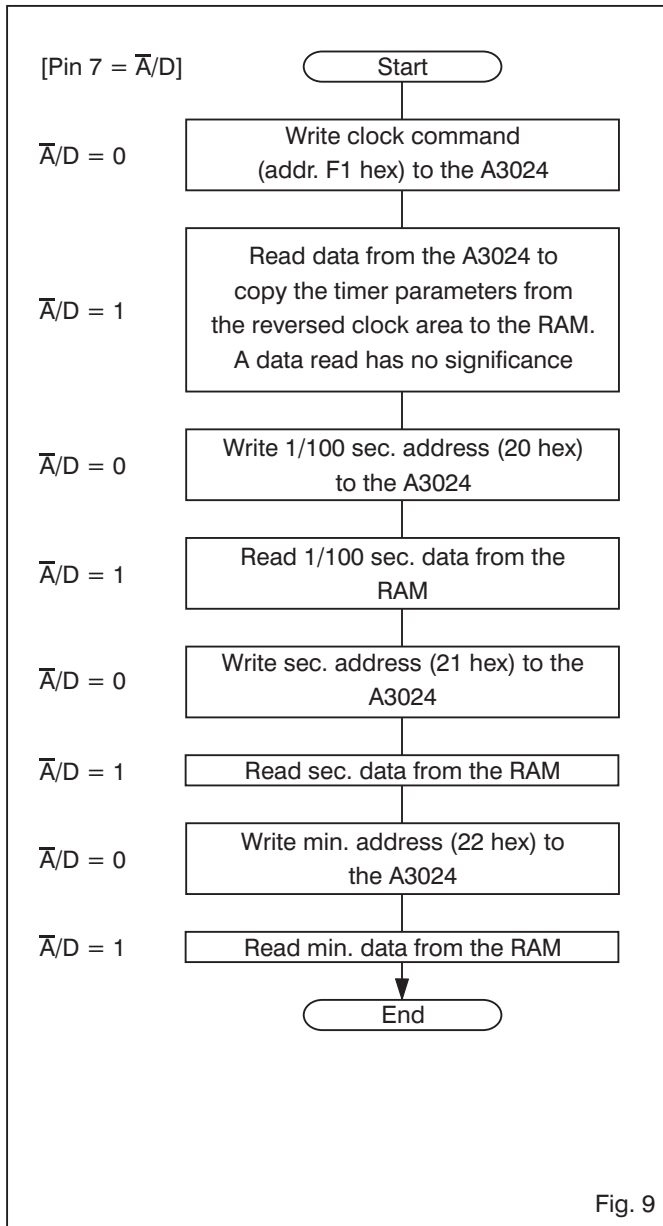

Setting the Timer (Time Set Lock Bit = 0)

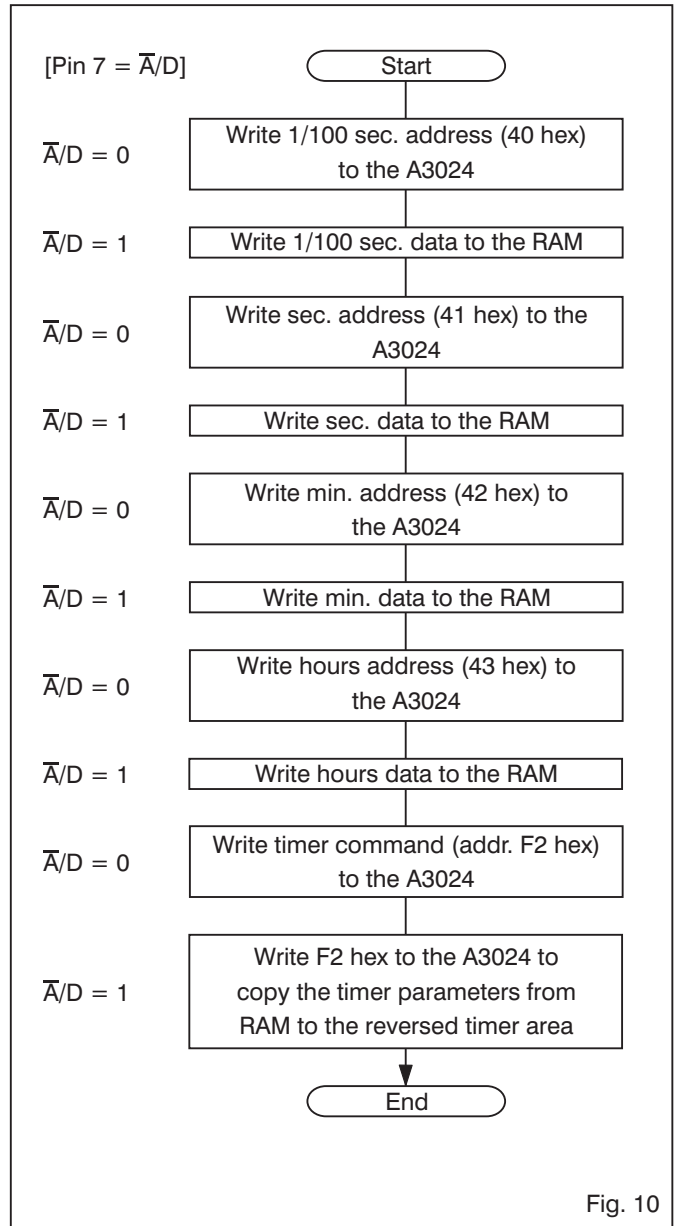

Note : Commands are only valid as commands when the \bar{A}/D line is low. Writing F2 hex with the \bar{A}/D line high, as in the last box of Fig. 8, serves only to activate the A3024 write pin which determines the direction of transfer.



Alarm

An alarm date and time may be preset in RAM addresses 30 to 34 hex. The alarm function can be activated by setting the alarm enable / disable bit (addr. 00 hex, bit 2). Once enabled the preset alarm time and date are compared, every internal time update cycle (10 ms), with the clock parameters in the reserved clock area. When the clock parameters equal the alarm parameters the alarm flag (addr. 01 hex, bit 5) is set. If the alarm mask bit (addr. 01 hex, bit 1) is set, the $\overline{\text{IRQ}}$ pin goes active. The alarm flag indicates to software the source of the interrupt. $\overline{\text{IRQ}}$ will remain active until software acknowledges the interrupt by clearing the alarm flag. If the alarm is enabled, and an alarm address set to FF hex, this parameter is not compared with the associated clock parameter. Thus it is possible to achieve a repeat feature where an alarm occurs every programmed number of seconds, or seconds and minutes, or seconds, minutes and hours. The A3024 pulls the open drain $\overline{\text{IRQ}}$ line active low during standby when an alarm interrupt occurs.

If the 12/24 hour mode is changed then the alarm hours must be re-initialised.

Note: The user should ensure that a time lapse of at least 60 microseconds exists between the falling edge of the $\overline{\text{IRQ}}$ and the clearing of the alarm flag.

$\overline{\text{IRQ}}$

The $\overline{\text{IRQ}}$ output is used by 4 of the A3024's features.

These are:

- 1) Pulse, to provide periodic interrupts to the microprocessor at preprogrammed intervals;
- 2) Alarm to provide an interrupt to the microprocessor at a preprogrammed time and date;
- 3) Timer, to provide an interrupt to the microprocessor when the timer rolls over from 23:59:59:99 to 00:00:00:00; and
- 4) Frequency trimming (see section "Frequency Trimming").

The first 3 features listed are similar in the way they provide interrupts to the microprocessor. Each of the 3 has an enable / disable bit, a flag bit, and an interrupt mask bit. The enable / disable bit allows software to select a feature or not. A set flag bit indicates that an enable feature has reached its interrupt condition. Software must clear the flag bit. The interrupt mask bit allows or disallows the $\overline{\text{IRQ}}$ output to become active when the flag bit is set. The $\overline{\text{IRQ}}$ output becomes active whenever any interrupt flag is set which also has its mask bit set. For all sources of maskable interrupts within the A3024, the $\overline{\text{IRQ}}$ output will remain active until software clears the interrupt flag. The $\overline{\text{IRQ}}$ output is the logical OR of all the unmasked interrupt flags. The $\overline{\text{IRQ}}$ output is open drain so an external pullup to V_{DD} is needed. In standby ($\overline{\text{PF}}$ active) the $\overline{\text{IRQ}}$ output will be active if the alarm mask bit (addr. 01 hex, bit 1) is set and the alarm flag is also set. The timer or the pulse feature cannot cause the $\overline{\text{IRQ}}$ output to become active while in standby.

Synchronization

There are 3 ways to synchronize the A3024. It can be synchronized to 50 Hz, the nearest second, or the nearest minute. Synchronization mode is selected by setting one of the

bits 5 to 7 at addr. 02 hex, in accordance with Table 8. If more than one bit is set then all the synchronization bits are disabled. If the $\overline{\text{SYNC}}$ input is set low for longer than 200 μs , while in the synchronization mode, the clock will synchronize to the falling edge of the signal. Synchronization to the nearest second implies that the 1/100 seconds are cleared to zero and if the contents were > 50 , the seconds register is incremented. Synchronization to the nearest minute implies that the seconds are cleared to zero and if the contents were > 30 , the minutes register is incremented. Fractions of seconds are cleared.

Pulse

There are 4 programmable pulse frequencies available on the A3024, these are every 10 ms, 100 ms, second or minute. The pulse feature is activated by setting the pulse enable / disable bit at address 00, bit 1. The pulse frequency is selected by setting one of the bits 0 to 3 at address 02 hex (see Table 8). If more than one of the pulse bits are set then the feature is disabled. At the selected interval the pulse flag bit (addr. 01 hex, bit 4) is set. If the pulse mask bit (addr. 01 hex, bit 0) is set then the $\overline{\text{IRQ}}$ pin goes active. The pulse flag indicates to software the source of the interrupt. $\overline{\text{IRQ}}$ will remain active until software acknowledges the interrupt by clearing the pulse flag. The pulse feature is disabled while in standby. Upon power restoration the pulse feature is enabled if enabled prior to standby. See also the section "Frequency Tuning".

Note: The user should ensure that a time lapse of at least 60 microseconds exists between the falling edge of the $\overline{\text{IRQ}}$ and the clearing of the pulse flag.

Time Set Lock

The time set lock control bit is located at address 00 hex, bit 5 (see Table 6). When set by software, this bit disables any transfer from the RAM to the reserved clock and timer area as well as inhibiting any write to the digital trimming register at address 10 hex. When the time set lock bit is set the following transfer operations are disabled:

- The clock command followed by write,
- the timer command followed by write,
- the clock and timer command followed by write, and
- writing to the digital trimming register.

A set bit prevents unauthorized overwriting of the reserved clock and timer area. Reading of the reserved clock and timer area, using the commands, is not affected by the time set lock bit. Clearing the time set lock bit by software will re-enable the above listed commands. On initialisation the time set lock bit is cleared. The time set lock bit does not affect the user RAM (addr. 50 to 5F hex).

Frequency Tuning

The A3024 offers a key feature called "Digital Trimming", which is used for the clock accuracy adjustment. Unlike the traditional capacitor trimming method, which tunes the crystal oscillator, the digital trimming acts on the divider chain, allowing the clock adjustment by software. The oscillator frequency itself is not affected.



The Principle of Digital Trimming

With the digital trimming disabled (i.e. digital trimming register set to 00 hex), the oscillator and the first stages of the divider chain will run slightly too fast (typ. 210 ppm: ppm = parts per million), and will generate a 100 Hz signal with a frequency of typically 100.021 Hz. To correct this frequency, the digital trimming logic will inhibit every 31 seconds, a number of clock pulses, as set in the digital trimming register. Since the duration of 31 seconds corresponds to 1'015'808 oscillator cycles, the digital trimming has a resolution of 0.984 ppm. In other words, every increment by 1 of the digital trimming value will slow down the clock by 0.984 ppm, which permits the accuracy of ±0.5 ppm to be reached. Note that a 1 ppm error will result in a 1 second difference after 11.5 days, or a 1 minute difference after 694 days! The trimming range of the A3024 is from 0 to 251 ppm. The 251 ppm correction is obtained by writing 255 (FFhex) into the digital trimming register.

How to Determine the Digital Trimming Value

The value to write into the digital trimming register has to be determined by the following procedure:

1. Initialise the A3024 by writing a 1 and then a 0 into the "Initialisation Bit" of the status register 2 (addr. 02 hex, bit 4). This activates the frequency tuning mode in status register 0 (addr. 00 hex, bit 1) and clears the other status bits.
2. Write the value 00 hex into the digital trimming register (addr. 10 hex). From now, the \overline{IRQ} output (open drain) will deliver the 100 Hz signal, which has a 20% duty cycle.
3. Measure the duration of 21 pulses at the \overline{IRQ} output, with the trigger set for the falling edge. It is possible also to divide the \overline{IRQ} frequency by 21, using a TTL or CMOS external circuit.
4. Compute the frequency error in ppm:

$$\text{freq. error} = \frac{210 \text{ ms} - \text{measured value in ms}}{210 \text{ ms}} \times 10^6$$

5. Compute the corrective value to write into the digital trimming register.
Digital trimming value = frequency error / 0.984
6. Write this value into the digital trimming register.
7. Switch off the frequency tuning mode in status 0 (addr. 00 hex, bit 0 set to 0).

The Real Time Clock circuit will now run accurately at an operating temperature equal to the calibration temperature. If the operating temperature differs from the one at calibration time, the graphs shown on Fig. 4 and 5 will help in determining the definitive value. If the mean operating temperature of the equipment is not known at calibration time, the equipment user will do the final correction with a software provided by the system designer. To avoid the calibration procedure, it is possible also to set the digital trimming register to 210 (D2 hex) as a standard starting value, and let the final equipment user perform the final adjustment on site, which will take the real temperature into account.

Time Correction at Room Temperature

Let us consider that the duration of 21 pulses of the \overline{IRQ} signal is 209.97 ms at room temperature.

The frequency error is:

$$(210 - 209.97) / 210 \times 1E + 06 = 142.857 \text{ ppm.}$$

The value for the digital trimming register is:

$$142.857 / 0.984 = 145.18, \text{ rounded to } 145 \text{ ppm (91 hex).}$$

Time Correction with Change of Temperature

If the mean temperature on site is known to be 45 °C, the frequency error determined at room temperature has to be modified, using the graphs or the equation on Fig. 5.

$$\Delta f/f = -0.038 \times (45 - 25)^2 = 15.2 \text{ ppm}$$

The trimming value for 45 °C will be:

$$(142.857 \text{ ppm} - 15.2 \text{ ppm}) / 0.984 = 129.73, \text{ rounded to } 130 \text{ (82 hex).}$$

12 / 24 Hour Data Format

The A3024 can run in 12 hour or 24 hour data format. On initialisation the 12/24 hour bit at addr. 00 bit 4 is cleared putting the A 3024 in 24 hour data format. If the 12 hour data format is required then bit 4 at addr. 00 must be set. In the 12 hour data format the AM/PM indicator is the MSB of the hours register addr. 23 bit 7. A set bit indicates PM. When reading the hours in the 12 hour data format software should mask the MSB of the hours register. In the 24 hour data format the MSB is always zero.

The internal clock registers change automatically between 12 and 24 hour mode when the 24/12 hour bit is changed. **The alarm hours however must be rewritten.**

Test

From the various test features added to the A3024 some may be activated by the user. Table 6 shows the test bits. Table 10 shows the three available modes and how they may be activated.

The first accelerates the incrementing of the parameters in the reserved clock and timer area by 32.

The second causes all clock and timer parameters, in the reserved clock and timer area, to be incremented in parallel at 100 Hz with no carry over, ie. independently of each other.

The third test mode combines the previous two resulting in parallel incrementing at 3.2 kHz.

While test bit 1 is set (addr. 00 hex, bit 7) the digital trimming action is disabled and no pulses are removed from the divider chain. Test bit 0 (addr. 00 hex, bit 6) can be combined with digital trimming (see section "Frequency Tuning"). To leave test, the test bits (addr. 00 hex, bits 6 and 7) must be cleared by software. Test corrupts the clock and timer parameters and so all parameters should be re-initialised after a test session.

Test Modes

Addr. 00hex bit 7	Addr. 00hex bit 6	Function
0	0	Normal Operation
0	1	Acceleration by 32
1	0	Parallel increment of all clock and timer parameters at 100 Hz with no carry over; dependent on the status of bit 3 at address 00 hex
1	1	Parallel increment of all clock and timer parameters at 3.2 kHz with no carry over; dependent on the status of bit 3 at address 00 hex

Table 10



Battery or Supercap Connection

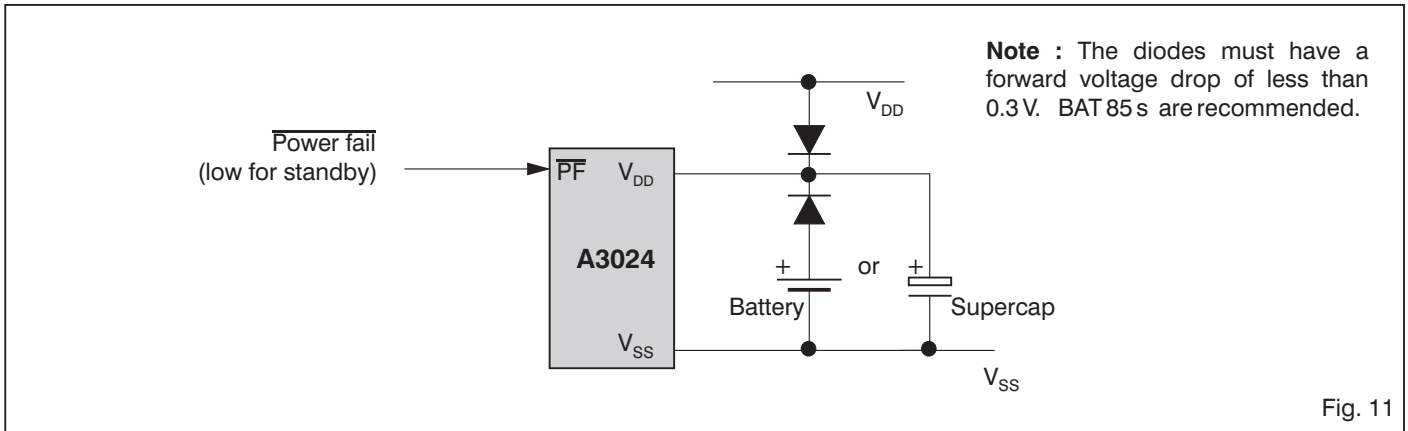

Fig. 11

Typical Applications

A 3024 Interfaced with Intel CPU (\overline{RD} and \overline{WR} pulse)

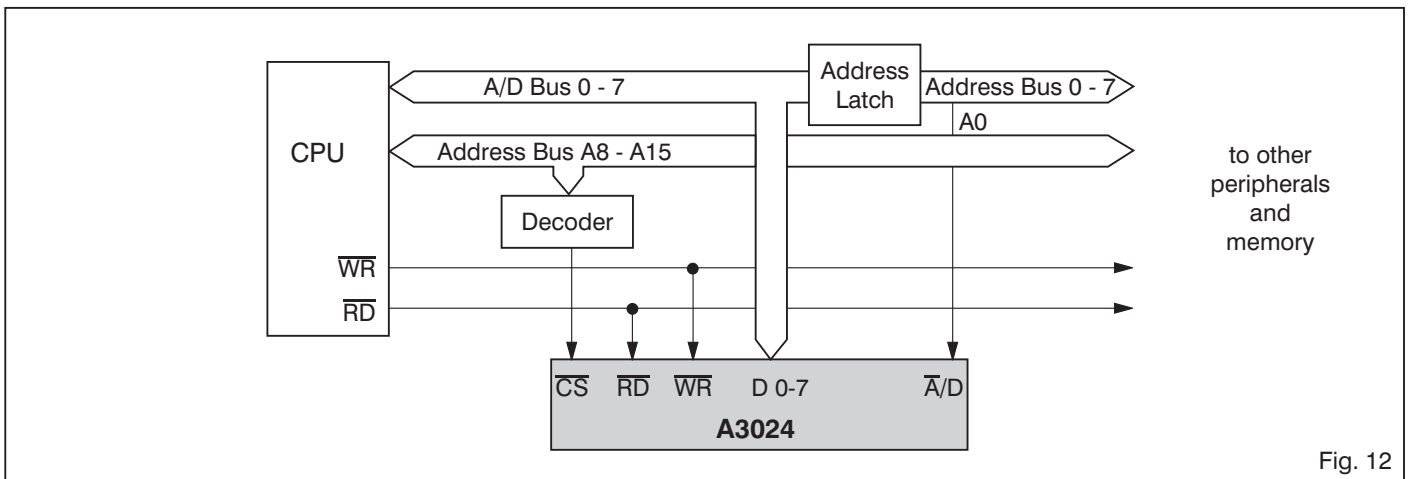

Fig. 12

A 3024 Interfaced with Motorola CPU (\overline{DS} or \overline{RD} pin tied to \overline{CS} , and R/ \overline{W})

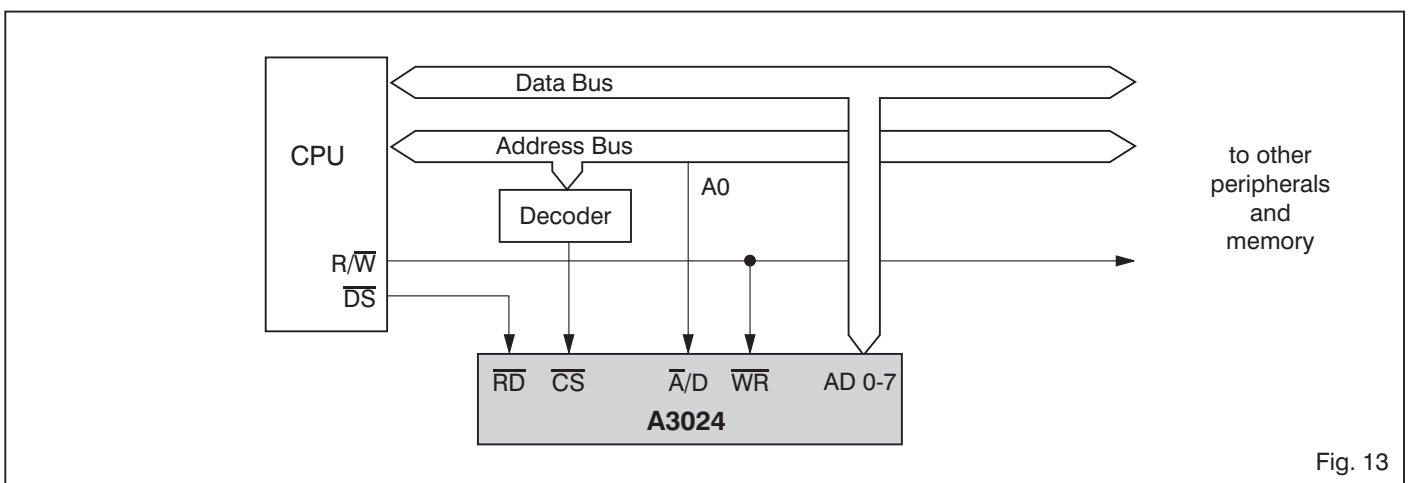

Fig. 13

Process Application

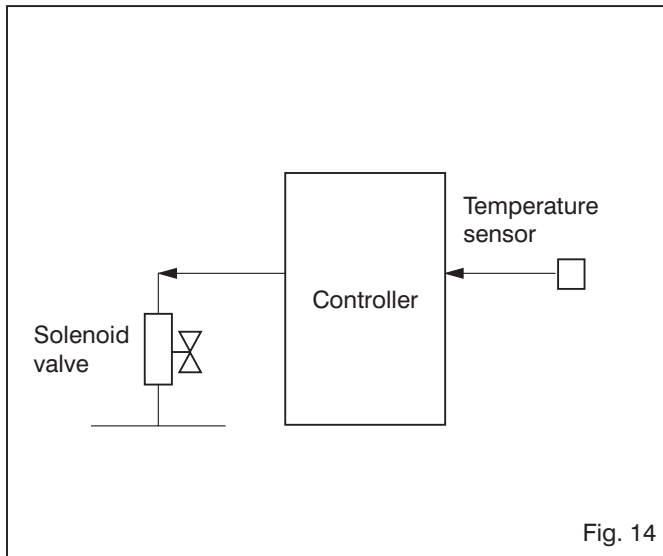

Fig. 14

- The formula in Fig. 5 is used by software to continually update the digital trimming register and so compensate the A3024 for the ambient temperature.
- The timer is used to measure the duration the valve is on.
- The alarm feature is used to turn the controller power on and off at the time programmed by software. The A3024 pulls \overline{IRQ} active low on an alarm even in standby and thus can control the power on/off switch for the controller.
- The user RAM provides the controller with non volatile RAM for vital parameters. For example :
 - 1) the total on time for the valve to enable software to compute energy usage and also to identify when service is needed - 3 bytes
 - 2) average on time for the valve - 2 bytes
 - 3) maximum temperature ever encountered together with the time and date - 6 bytes
 - 4) date of last service and service man's ID - 4 bytes
 - 5) identification code for the controller - 1 byte

Crystal Layout

In order to ensure proper oscillator operation we recommend the following standard practices:

- Keep traces as short as possible.
- Use a guard ring around the crystal.

Fig. 15 shows the recommended layout.

Oscillator Layout

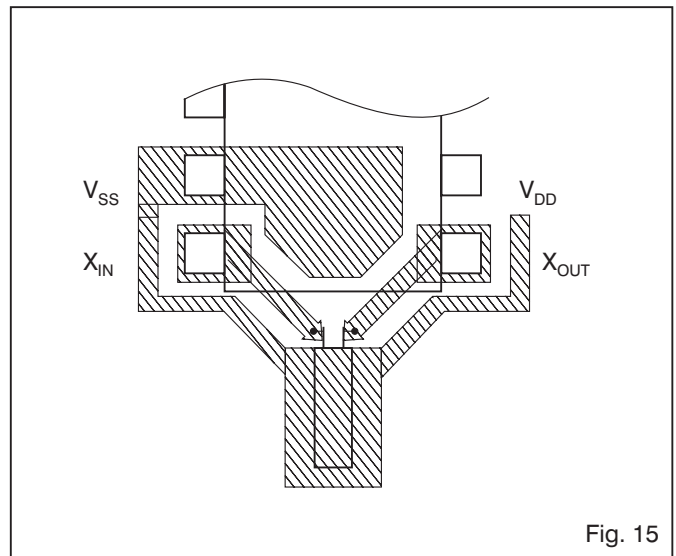

Fig. 15

External Clock

An external signal generator can be used to drive the divider chain of the A 3024. Fig. 16a and 16b show how to connect the signal generator.

Signal Generator

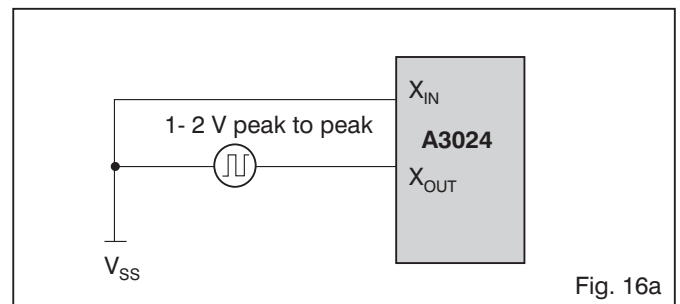
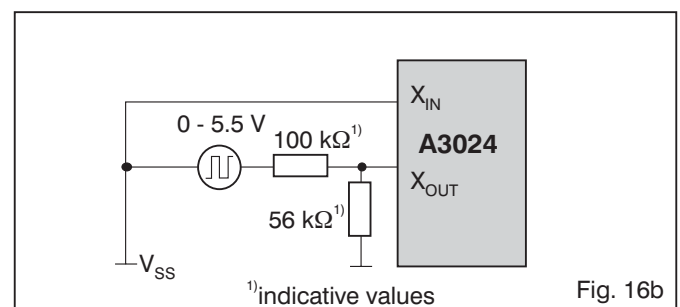

Fig. 16a

Note : The peak value of the signal provided by the signal generator should not exceed 2V on X_{OUT} .



¹⁾indicative values

Fig. 16b

Note : The peak value of the signal provided by the signal generator should not exceed 2V on X_{OUT} .



Package and Ordering Information

Dimensions of 20-Pin SOIC Package

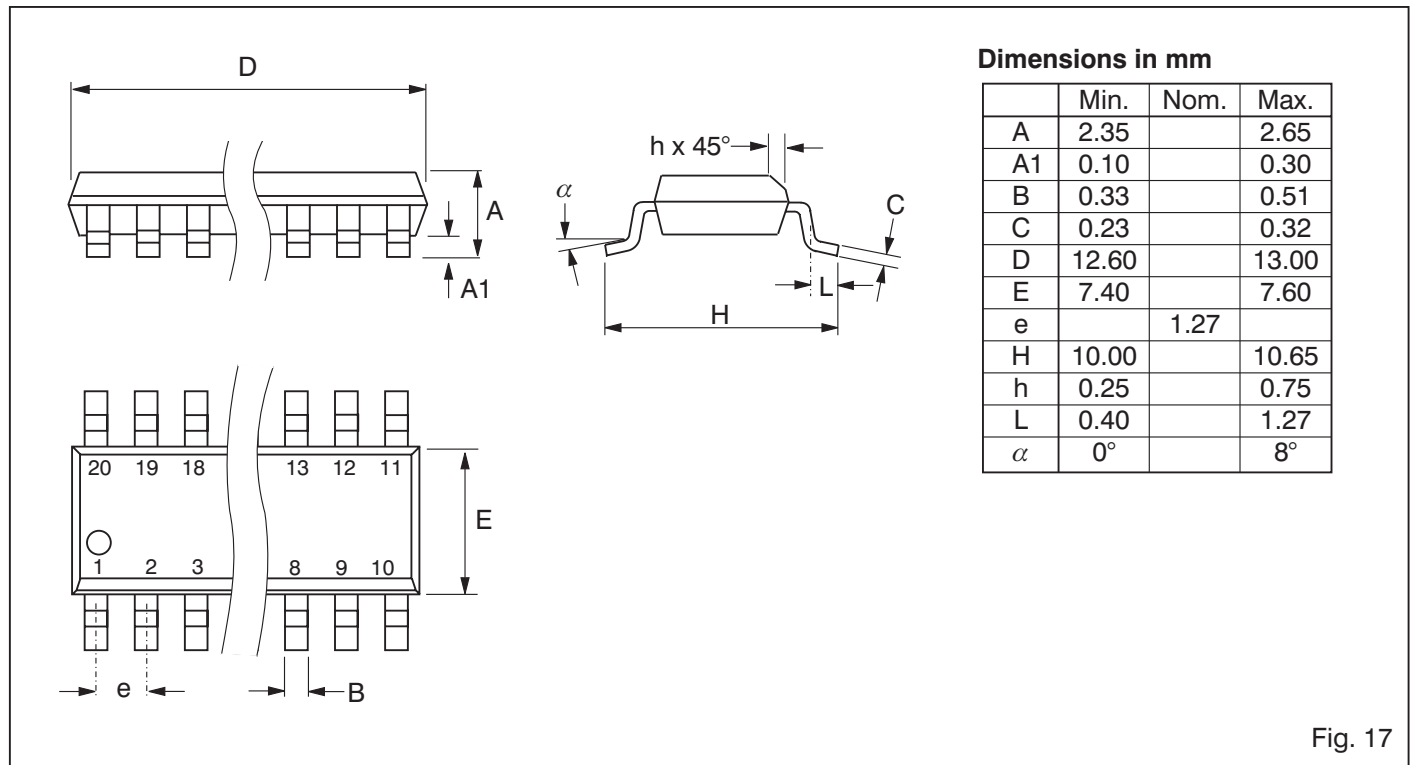

Fig. 17

Dimensions of 20-Pin Plastic DIP Package

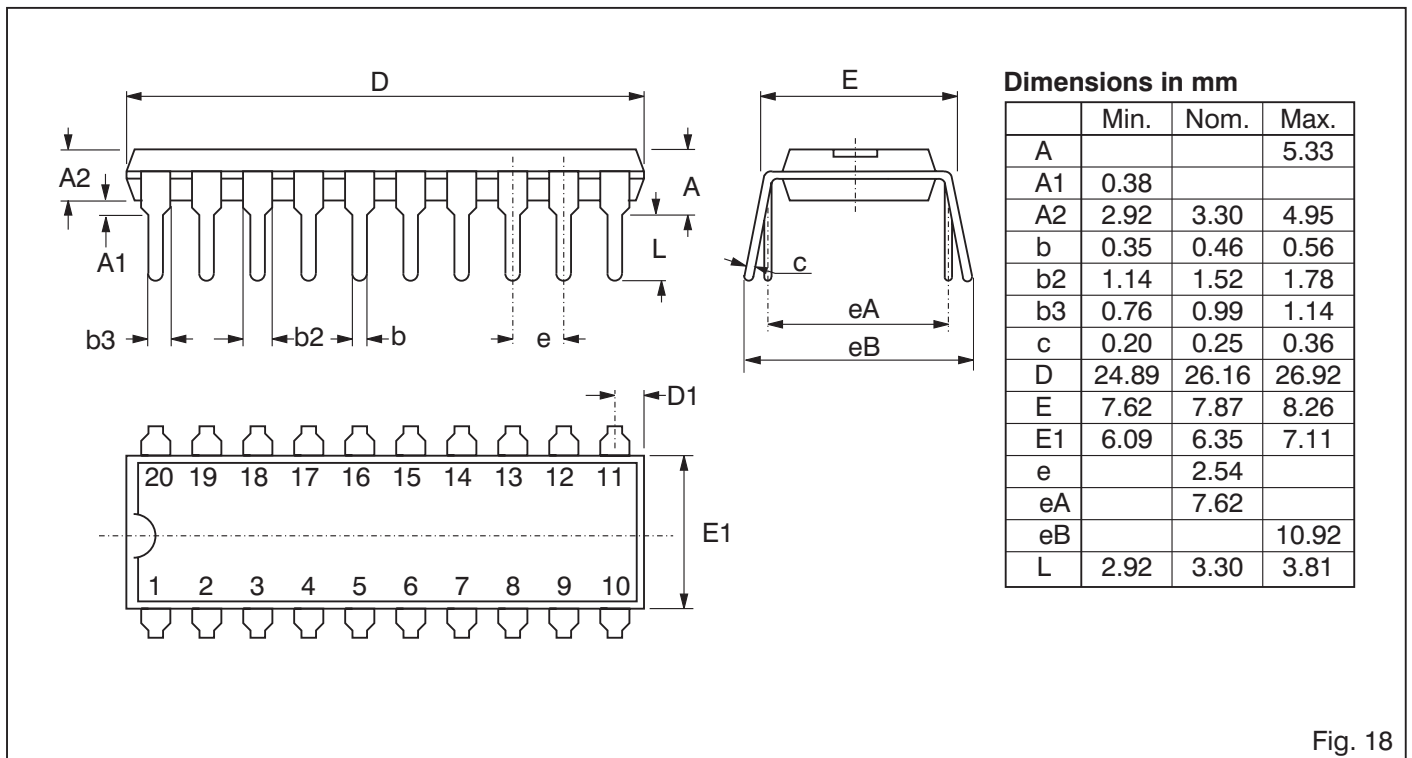

Fig. 18



Ordering Information

When ordering, please specify the complete part number.

Part Number	Package	Delivery Form	Package Marking (first line)
A3024SO20B	20-pin SOIC	Tape & Reel	A3024 20S
A3024SO20A	20-pin SOIC	Stick	A3024 20S
A3024DL20A	20-pin plastic DIP	Stick	A3024 20PI

EM Microelectronic-Marine SA ("EM") makes no warranties for the use of EM products, other than those expressly contained in EM's applicable General Terms of Sale, located at <http://www.emmicroelectronic.com>. EM assumes no responsibility for any errors which may have crept into this document, reserves the right to change devices or specifications detailed herein at any time without notice, and does not make any commitment to update the information contained herein.

No licenses to patents or other intellectual property rights of EM are granted in connection with the sale of EM products, neither expressly nor implicitly.

In respect of the intended use of EM products by customer, customer is solely responsible for observing existing patents and other intellectual property rights of third parties and for obtaining, as the case may be, the necessary licenses.

Important note: The use of EM products as components in medical devices and/or medical applications, including but not limited to, safety and life supporting systems, where malfunction of such EM products might result in damage to and/or injury or death of persons is expressly prohibited, as EM products are neither destined nor qualified for use as components in such medical devices and/or medical applications. The prohibited use of EM products in such medical devices and/or medical applications is exclusively at the risk of the customer.