

# PHILCO TV

## SCHEMATIC DIAGRAMS

MODEL 48-700 THRU 53T2750



Publication of this book was made possible through the  
Courtesy and Co-operation of Philco Corp.

# 1947-1953

**\$2.50**



# Talk about Convenience!



ANNOUNCING THE

## TELEBINDER

In response to your many requests, there will shortly be available the new **TELEBINDER**, designed especially for use with Wallace's **TELAIDES**. Ruggedly constructed, the binder has metal rings which open or close instantly for the addition or removal of material. Pages lie flat when the **TELEBINDER** is opened. The **TELAIDES** you now own are punched to fit exactly the rings of this new binder.



### USE TELEBINDERS FOR:

- Combining **TELAIDES** for several manufacturers into a single traveling service reference book!
- Combining 1954 and other added information for a single manufacturer, with the initial **TELAIDE** covering 1946-1953, into one convenient unit!
- Collating information in any other manner to fit your individual needs.

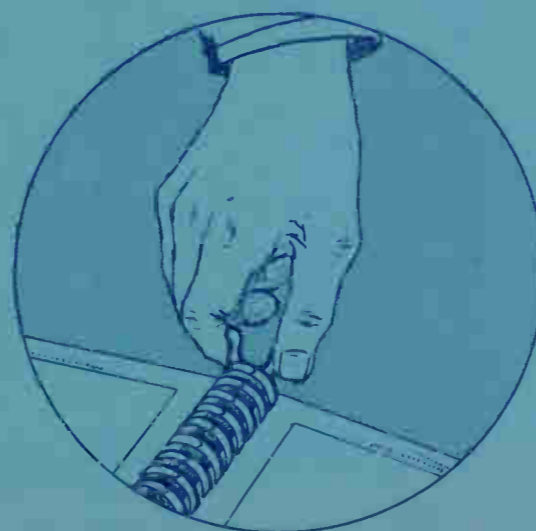

### THE TELEBINDER IS CONSTRUCTED SO AS TO HAVE A LONG AND USEFUL LIFE.

- Cover material is extremely tough, flexible and attractively stamped.
- No tugging at the rings, or jammed fingers--separate levers at opposite ends of the binder spine instantly open or close the twenty-two steel rings.
- Binder and cover are brass riveted.



134 - 136 DAY STREET, JAMAICA PLAIN 30, MASSACHUSETTS

YOUR JOBBER WILL ACCEPT YOUR ORDER NOW, SO THAT YOU WILL BE ABLE TO ENJOY THE ADVANTAGES OF TELEBINDERS JUST AS SOON AS THEY ARE AVAILABLE.

MODEL	CODE	SCHEMATIC PAGE	PRODUCTION CHANGES PAGE
48-700	121	3	2
48-1000	122&25	9	4 to 8
48-1000-5	122	11	10
48-1001	121&22	13	12
48-1050-5	122	11	10
48-2500	121&22	17	14 to 16
1949 RADIO SCHEMATICS		37	36
49-702	121	34	
49-1002	121	19&21	18&20
49-1040	121	19&21	18&20
49-1040	123	27	22 to 26
49-1075	121&22&23	19	18
49-1076	122	19	18
49-1076	123	27	22 to 26
49-1077	122	27	
49-1150	121	29	28
49-1150	122&24	27	22 to 26
49-1150	123	29	28
49-1175	121	29	28
49-1175	122&24	27	22 to 26
49-1175	123	29	28
49-1240	121&23	19	18
49-1240	124	27	22 to 26
49-1275	121&23	19	18
49-1278	22	19	18
49-1278	23		
49-1279	121	27	22 to 26
49-1280	121		
49-1280	122	19	18
49-1450			
49-1475	121&23&23T	31	30
49-1480			
49-1450			
49-1475	123	33	32
49-1480			
49-1450			
49-1475	123T	35	32
49-1480			
1950 SERVICE HINTS			38 to 44
50-T701		34	
50-T702		34	
50-T1104		43&47	42 to 44
50-T1105		45	
50-T1106		45	
50-T1400		49&47	
50-T1401		49	
50-T1402		49&47	40 to 55
50-T1403		51	
50-T1404		47-51&3	
50-T1406		51&53	
50-T1430		49	
50-T1432		51	
50-T1443			
50-T1476			
50-T1477			
50-T1478			
50-T1479		57	56
50-T1481			
50-T1482			
50-T1483			
50-T1484			
50-T1600		59&61	58 to 60
50-T1630		63&65	62 to 64
50-T1632		59&61	58 to 60
50-T1633		59&61	58 to 60
51-PT1207			
51-PT1208			
51-PT1234		67	66
51-PT1282			

MODEL	CODE	R. F. CHASSIS PAGE	POWER CHASSIS PAGE	SCHEMATIC PAGE	PRODUCTION CHANGES PAGE
51-T1443B	121				
51-T1433M	121				
51-T1433L	121	31	A1	69	
51-T1433X&XL	121				68-86
51-T1433PM	121				
51-T1433PL	121	3P1	AP1	71	
51-T1433PW	121				
51-T1601&T	121	33			
51-T1601	122	32	C1	73	72-74-78
51-T1602	121	33			
51-T1602	122	32			
51-T1604	121	C	L		
51-T1604	122	B	J	70	74 to 75
51-T1604	125	B	L		
51-T1607	121	33	C1	73	72-74-78
51-T1607	122	32			
51-T1634	121	C	L	70	74 to 75
51-T1634	122	B	J	70	74 to 75
51-T1634	123	33	C1	73	72-74-78
51-T1634	124	32			
51-T1634	125	B	L	70	74 to 75
51-T1800	121	33			
51-T1800	122	32	C2	81	72-8
51-T1830	121	33			
51-T1832	121	33			
51-T1833	121	3P1	CP1	79	68-72-78-88
51-T1834	121	33	C2	81	72-8
51-T1835	121	3R2	CR3	79	75
51-T1836	123	34	C3	77	72-74
51-T1836	125	33	C2	81	72-8
51-T1838	124	3R2	CR3	79	75
51-T1870	121	3P1	CP1	79	68-72-78-88
51-T1871	121	3P1	CP1	79	68-72-78-88
51-T1871	122	35	CP1	84	72-78-88
51-T1872	121	3P1	CP1	79	68-72-78-85-88
51-T1872	122	35	CP1	84	72-78-88
51-T1874	121				
51-T1875	121	3P1	CP1	79	68-72-78-88
51-T1876	121				
51-T2102	121	35	F2		
51-T2130	121	35	F2		
51-T2132	121	35	F2		
51-T2133	121	3R2	FR2		
51-T2134	124	35	F2	80	72-78-86-88
51-T2136	124	35	F2		
51-T2138	124	3R2	FR2		
51-T2170	121	35	F2		
51-T2175	124	35	F2		
51-T2176	124	3R2	FR2		
AM-FM TUNER RT-2 FOR 51 MODELS				PAGE 41	
RT-4 FOR 51 MODELS				PAGE 76	
52-T1610	122	32	C1	73	72-74-78
52-T1612	122	32	C1	73	72-74-78
52-T1802	123	37	C2	82	72-78-88
52-T1802	124	71	G1	100	101&97
52-T1804	122	33			
52-T1804	123	37			
52-T1808	122	33			
52-T1810L	122	33			
52-T1810L	123	37	C2	82	72-78-88
52-T1810M	122	33			
52-T1810M	123	37			
52-T1812&L	122	33			
52-T1812	123	37			
52-T1820	121	41	D1	90	91&89
52-T1821	123	37	C2	82	72-78-88
52-T1821	124	71	G1	100	101&97
52-T1822	124	71	G1	100	101&97
52-T1831	122	33	C2	82	72-78-88

MODEL	CODE	R. F. CHASSIS PAGE	POWER CHASSIS PAGE	SCHEMATIC PAGE	PRODUCTION CHANGES PAGE
52-T1839	122	33			
52-T1839	123	37			
52-T1840	122	33			
52-T1840	123	37			
52-T1841L	123	37			
52-T1842	122	33	C2	82	72-78-88
52-T1842	123	37			
52-T1842L	123	37			
52-T1842L	124	33			
52-T1844	122	33			
52-T1844	123	37			
52-T1844&L&W	124	33			
52-T1845&L	124	3R2	CR3	79	75
52-T1850	121	41	D1	90	91&89
52-T1882	122	35			
52-T1882	123	38	CP1	84	72-78-86-88
52-T1882W	122	35			
52-T2106	121	41	D1	90	91&89
52-T2108	121	41	D1	90	91&89
52-T2110&L	122	35	F2	84-87	86 to 88
52-T2110&L	123	38			
52-T2120	121	41	D1	90	91&89
52-T2120	124	71	G1	100	101&97
52-T2122					
52-T2122L	121	41	D1	90	91&89
52-T2140					
52-T2140	122	35	F2	82-4	85-86-7
52-T2142&L	122	35	F2	84-87	86-88
52-T2142&L	123	38			
52-T2144	121	41	D1	90	91&89
52-T2150W	124	71	G1	100	101&97
52-T2151	121	41	D1	90	91&89
52-T2151	124	71	G1	100	101&97
52-T2151L	124	71	G1	100	101&97
52-T2157	125	42	G2	92	93&96
52-T2175	124	35	F2	84-87	86-88
52-T2176					
52-T2182&L	121	44	D4	94	95&96
52-T2224	121	41	D1	90	91&89
52-T2244	121	41	D1	90	91&89
52-T2245	121	44	D4	94	95&96
52-T2252	121	41	D1	90	91&89
52-T2252	124	71	G1	100	101&97
52-T2253	121	44	D4	94	95&96
52-T2254					
52-T2256					
52-T2258	121	41	D1	90	91&89
52-T2259					
52-T2275	123	38	F2	84	86-87-8
52-T2282	121	44	D4	94	95&96
52-T2283	121	44	D4	94	95&96
53-T1824					
53-T1825	123	81	H1	102	103&99
53-T1826					
53-T1827	126	91	J1		
53-T1827F	126	91	J1		
53-T1827	128	91	J2	106	107&98-99
53-T1827F	128	91	J2		
53-U1827	126	91	J1		
53-T1852					
53-T1852F	123	81	H1	102	103&99
53-T1852L					
53-T1852L	124	71	G1	100	101&97
53-U1853	126	91	J1	106	107&98-99
53-U1853L	126	91	J1	106	107&98-99
53-T1854	123	81	H1	102	103&99
53-T1854L	123	81	H1	102	103&99
53-T1883	123	84	H4	104	105&98-99
53-T1884	123	84	H4	104	105&98-99

MODEL	CODE	R. F. CHASSIS PAGE	POWER CHASSIS PAGE	SCHEMATIC PAGE	PRODUCTION CHANGES PAGE
53-T1886	123	84	H4	104	105&98-99
53-T1886L	123	84	H4	104	105&98-99
53-T2124					
53-T2124L	123	81	H1	102	103&99
53-T2125					
53-T2125	124	71	G1	100	101&97
53-T2125L	123	81	H1	102	103&99
53-T2152L	124	71	G1	100	101&97
53-T2183	123	84	H4	104	105&98-99
53-T2226	123	81	H1	102	103&99
53-T2227	123	81	H1	102	103&99
53-T2228	126	91	J1	106	107&98-99
53-T2255	123				
53-T2255L	123				
53-T2255	133				
53-T2255L	133	81	H1	102	103&99
53-T2260	123				
53-T2262	123				
53-T2264	123				
53-T2266L	126	91	J1		
53-T2266LR	126	91R	J-1R		
53-U2266	126	91	J1		
53-T2266	128	91	J2		
53-T2268	126	91	J1	106	107&98-99
53-T2269	128	91	J2		
53-U2269	126	91	J1		
53-T2270	128	91	J2		
53-T2271	126	91	J1		
53-T2272	123	81	H1	102	103&99
53-T2273	126	91	J1	106	107&98-99
53-T2272L	123	81	H1	102	103&99
53-T2285					
53-T2285L	126	94	J4	108	109&99
53-T2286					
53-T2287					
53-T2750	127	97	J7	110	111

**Wallace's**  
TELAIDES

134-136 DAY STREET, JAMAICA PLAIN 30, MASS.

*Dear Sir:* Please forward FREE information, pertaining to SCHEMATIC DIAGRAM BOOKS listed below:

<b>EMERSON</b>	<b>RAYTHEON</b>
<b>ADMIRAL</b>	<b>WESTINGHOUSE</b>
<b>MOTOROLA</b>	<b>PHILCO</b>
<b>ZENITH</b>	<b>CROSLEY</b>
<b>SYLVANIA</b>	<b>COMBINATION 2:</b>
<b>COMBINATION 1:</b>	<b>Arvin</b>
<b>Stromberg Carlson</b>	<b>Tray-ler</b>
<b>Kaye-Halbert</b>	<b>Philmore</b>
<b>Starrett</b>	<i>All other makes to follow.</i>

NAME .....

ADDRESS .....

CITY ..... STATE .....

Your jobbers name .....

## SERVICE HINTS

### Breakdown of Background Control

In sets prior to Run 6, the background control, R108, may fail because of transients or surges under certain operating conditions. When replacing this control, it is suggested that the circuit be rewired as shown in figure 11. This change was incorporated in production in Run 6.

### Beat Interference

Beat interference due to a harmonic of the audio i-f beating against the picture carrier may be encountered in the first few runs of the Model 48-700, or in other runs if some repair work has been done to disturb the lead dress. If this condition is encountered, it is suggested that the following lead and parts dress be checked, and corrected if required.

1. The red lead from discriminator transformer (Z202) to the terminal junction of R208 and C211 should be pushed down close to the chassis.
2. The length of the condenser lead from C213 to pin 5 of the 6AL5 discriminator should be kept to one-half inch.
3. All speaker-cable leads and other wires in the vicinity of the discriminator tube should be dressed toward the front of the chassis and under the CONTRAST control R326.
4. The brown and yellow leads from the discriminator secondary winding to pins 1 and 2 of the discriminator tube should be twisted several times.
5. Dress the red lead from R100A to C103, and the two white leads from the power switch, R216, to the side of the horizontal output transformer, T501, nearest to condenser C503.

6. Dress the brown lead from L403 and the green lead from C408, in tuner assembly, away from the terminal strip that mounts C211, C214, and L205.

### Replacing Picture Tube

In sets prior to Run 6, when replacing the picture tube with one of a different type (7JP4, replacing 7GP4, or vice versa), it is desirable to change the second-anode voltage, to obtain optimum performance with minimum astigmatism.

For the 7JP4, best results are obtained with a second-anode voltage of +150v; connect the anode to the junction of R322 and R321.

For the 7GP4, best results are obtained with a second-anode voltage of +250v; connect the anode to the junction of R100A and C103.

The astigmatic control, which was added in Run 6, is used to adjust the second-anode voltage of the picture tube. Whenever this tube is replaced, the control should be adjusted as directed below.

### Adjusting Astigmatic Control

1. Tune in a station test pattern, preferably one having a wedge-type design.
2. Adjust the contrast and brilliance controls to produce a bright picture, just below "blooming."
3. Adjust the focus control for picture sharpness in one plane, either vertical or horizontal.
4. Adjust the astigmatic control for picture sharpness in the opposite plane.
5. Readjust the focus control.

## PRODUCTION CHANGES

RUN NO.	DESCRIPTION OF CHANGE	NEW OR ADDED PART NO.	OLD OR REMOVED PART NO.	REASON FOR CHANGE
1 to 4 inclusive	Changes in physical wiring. (Service Manual PR-1469 applies to Runs 1 to 4, inclusive.)			
5	Standoff for the 1B3GT was made longer. R535 (30,000 ohms) replaced by two ½-watt resistors in parallel: 47,000 ohms 150,000 ohms	54-7309-1 66-3473340* 66-4153340	54-7309 66-3333340*	Reduce high-voltage breakdown.  Temporary shortage of properly rated resistor.
6	R107 changed to 100,000 ohms, and rewired as shown in figure 11.  Addition of: R110 (astigmatic control), 500,000 ohms. R111, 100,000 ohms. C106, .0047 mfd. Wired as shown in figure 11.	66-4103340 33-5539-18 66-4103340* 45-3502*	66-3223340	Improve background-control operation.  Improve focus of picture tube with wide range of tube characteristics (7JP4 or 7GP4). See Adjusting Astigmatic Control.

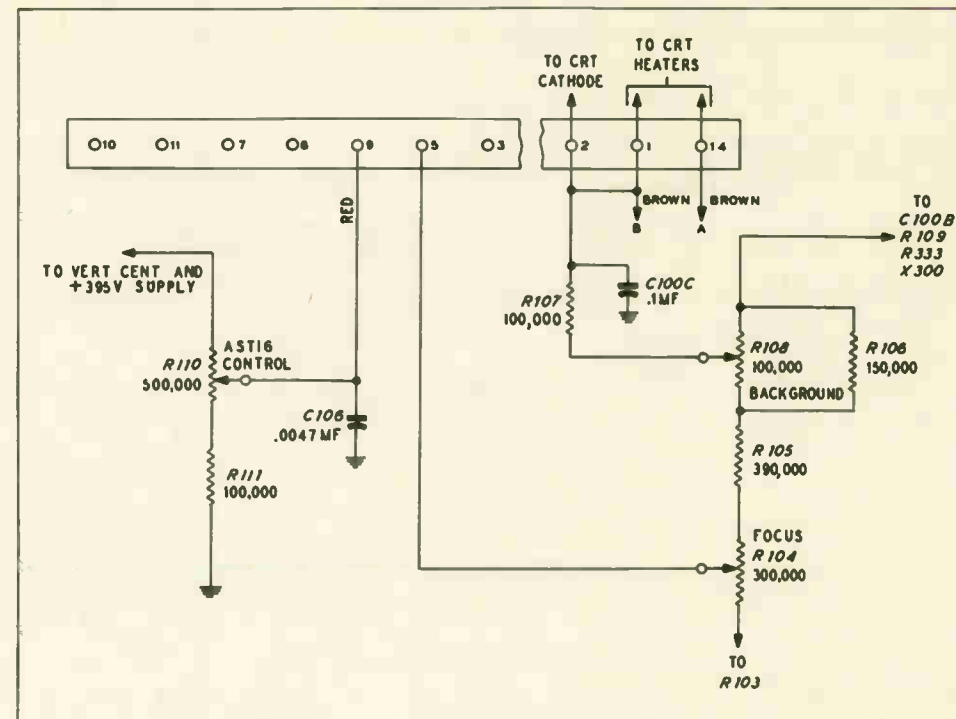
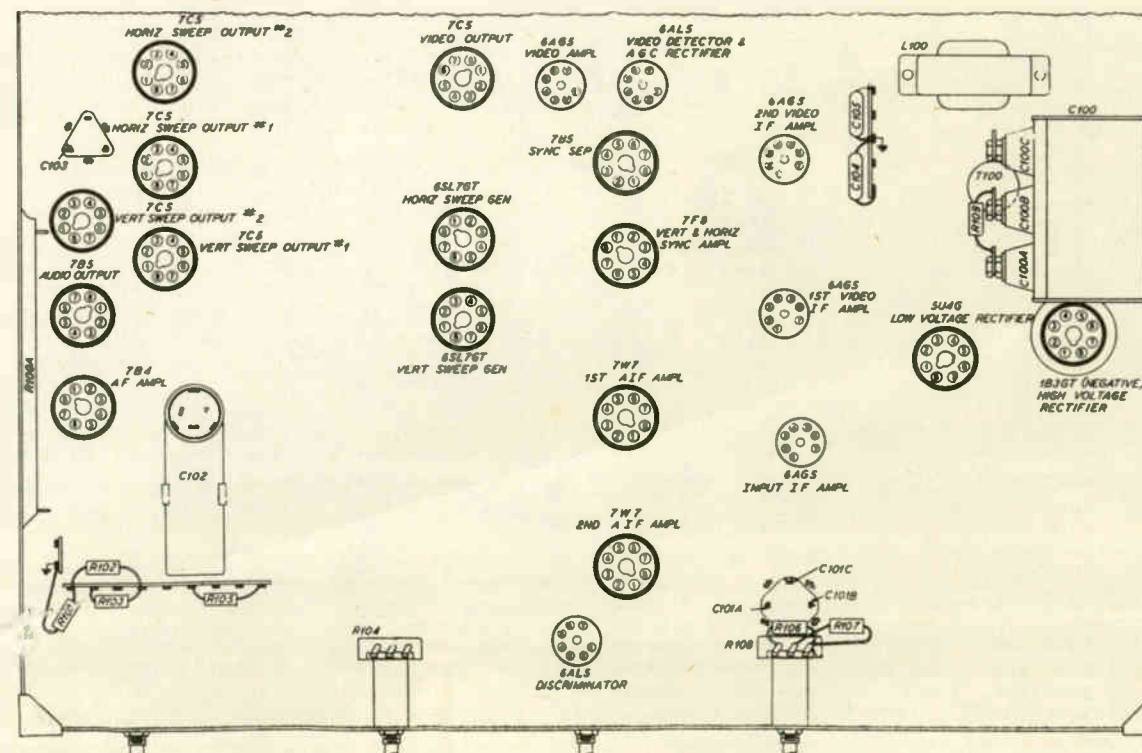

Figure 11. Addition of Astigmatic Control, Run 6

TP-5688



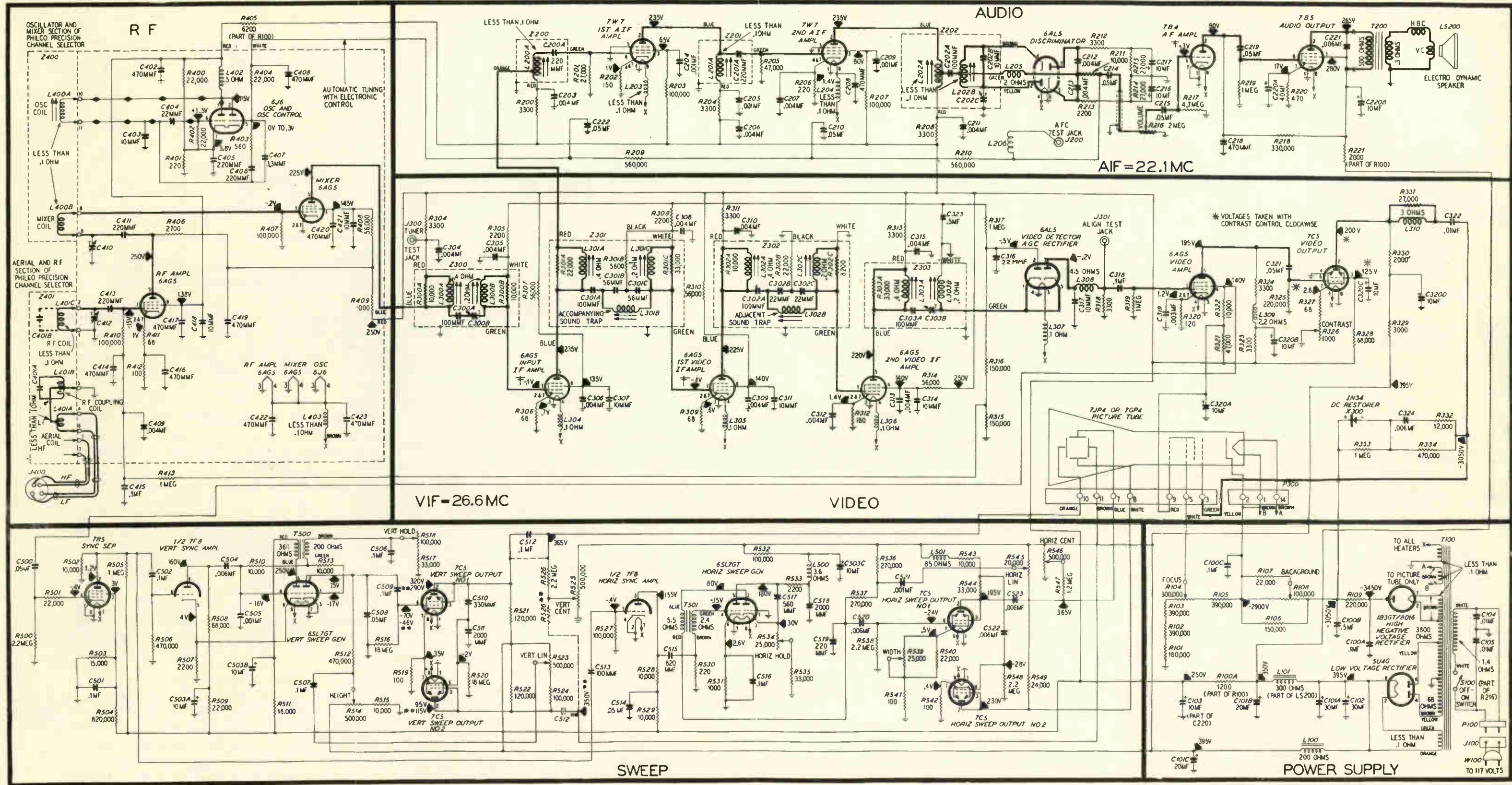
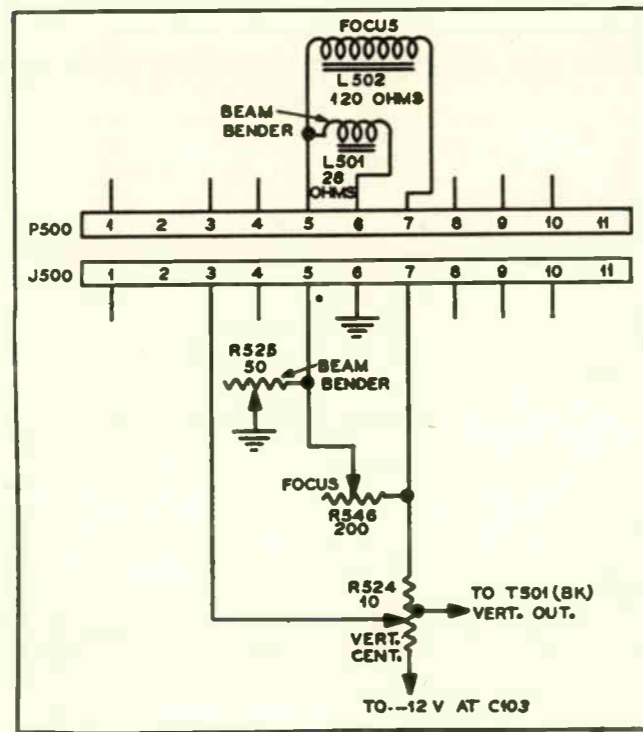

Figure 10. Philco Television Receiver Model 48-700, Sectionalized Schematic Diagram



TP-4084

Figure 13. Focus and Beam-Bender Changes

NOTE: In some sets there may be only a 330,000-ohm resistor; later, this resistor was shunted by a 560,000-ohm resistor (R550 above) to bring the resistance down to 270,000 ohms. When available, the 270,000-ohm resistor (Part No. 66-4273340) was used.

### Run 9, Code 125

Run 9, is the same as run 8 except as follows: R529 in run 8 was a 150,000-ohm resistor, Part No. 66-4154340. In run 9 it was changed to a 100,000-ohm resistor, Part No. 66-4104340.

## SERVICE HINTS

### Harmonic Beat Interference

Beat patterns may appear in the picture when operating on Channel 7; less frequently on Channels 4 and 11. This condition may be corrected by adding compensating and filter resistors to the FM discriminator circuit, as shown in the revised schematic, figure 14, and the layout drawing, figure 15.

It is recommended that the following changes be made when the chassis are serviced, or when Channels 4, 7, or 11 are adjusted for reception.

1. Remove the following parts carefully, as they are to be reinstalled.
  - a. C218, connected between pin 5 of the discriminator tube (6AL5) and ground.
  - b. C219, connected between pin 7 of the discriminator and ground.
  - c. R215, connected between pin 5 of the discriminator and ground.
  - d. R216, connected between pin 7 of the discriminator and terminal 3 of terminal board TB6.

e. Length of wire, connected between terminal 1 of terminal board TB3 and socket J200.

2. Install a wiring panel, Part No. 12W45661, at the location indicated by TB4 in figure 15. Note how the terminals are numbered, and make sure that the number 3 terminal is used as the mounting foot.
3. Connect the 27,000-ohm resistor R215 between terminals 2 and 4 of TB4, as shown in figure 15.
4. Connect the 27,000-ohm resistor R216 between terminals 1 and 4 of TB4.
5. Connect a bare wire jumper between terminals 3 and 4 of TB4.
6. Connect the 10-mf. condenser C218 between terminals 2 and 4 of TB4 (positive lead to terminal 2).
7. Connect the 10-mf. condenser C219 between terminals 1 and 4 of TB4 (positive lead to terminal 4).
8. Connect a 40-microhenry choke, Part No. 32-4143-1, between terminals 1 and 3 of TB3. (If terminal 3 is already in use, connect to any nearby vacant terminal.)

9. Connect a 3300-ohm, 1/2 watt, 10% resistor, Part No. 66-2338340, from pin 7 of the discriminator to terminal 1 of TB4.

10. Connect a 2200-ohm, 1/2 watt, 10% resistor, Part No. 66-2228340, from pin 5 of the discriminator to terminal 2 of TB4.

11. Connect a length of white wire from socket J200 to terminal 1 of TB3. (If some other terminal was used in step 8, use the same terminal for this connection).

### Microphonics on High-Frequency Channel

Low-frequency microphonics may be encountered, and are particularly noticeable on Channel 9. This effect may be reduced by making the following changes:

1. Remove both brown wires from pin 3 of the mixer tube (6AG5).
2. Solder them together, and insulate by a piece of spaghetti.
3. Add a choke, Part No. 32-4112-11, between pin 4 of the r-f-amplifier tube (6AG5) and pin 3 of the mixer tube. Make the choke leads as short as possible, and dress the choke away from other components.

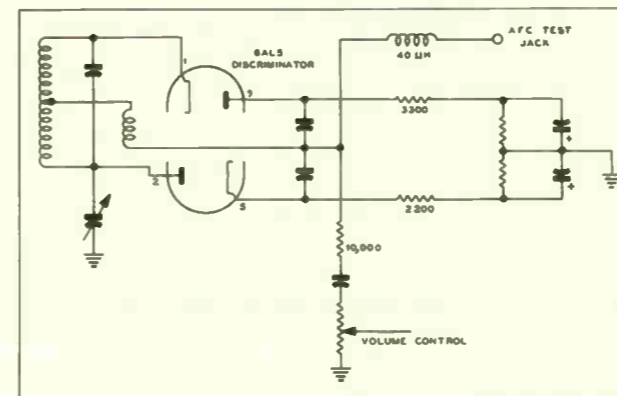

TP9-316

Figure 14. Revised Discriminator Schematic

### A-G-C Adjustment

The purpose of automatic gain control in Philco television receivers is to maintain the output of the video detector at 2 volts, peak-to-peak, to prevent overloading of the video amplifiers.

The a.g.c. may be adjusted in the field by using the stations that are being received and a calibrated oscilloscope. Connect the oscilloscope to the video test jack, and turn the Channel Selector to the weakest station in the area. Adjust the a-g-c potentiometer for 2 volts, peak-to-peak. Leave the oscilloscope connected, and turn the Channel Selector to the other stations, noting the difference in the peak-to-peak voltage readings. If any signal produces 3 volts of a-g-c voltage,

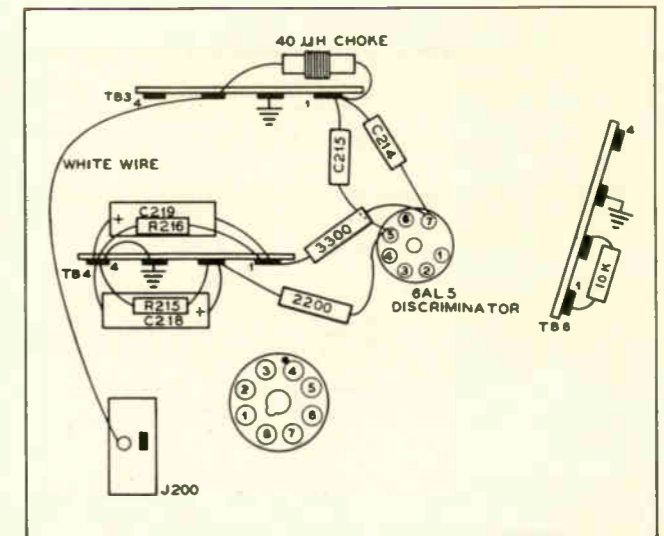

TP9-315

Figure 15. Bottom View of Parts Layout in Discriminator Change

or more, it is recommended that a loading resistor be placed across the primary winding of the aerial snap-in coil for that station. The value of the resistor may vary between 10 ohms and 100 ohms and should be found experimentally. Make sure that the resistor is of the non-inductive carbon type.

### Hum Due to Tuner Supply Lead Pickup

Hum modulation may be reduced by the addition of an isolating choke in the "B" supply lead and an additional isolating choke in the filament circuit.

The choke may be added to the "B" supply circuit as follows:

1. Locate the terminal strip to which R304, C304, the red lead from Z300, and the jumper from J300 are connected. Remove these leads from the terminal to which they are connected.
2. Reconnect all the above components to J300, leaving out the jumper from J300 to the terminal.
3. Remove the red lead that connects L402 to R405.
4. Rewire the above red lead to the terminal left vacant in step 1, dressing the red lead along the side walls of the chassis, and keeping it clear of as many components as possible.
5. Add an isolating choke, Part No. 32-4112-2, covered by spaghetti, between L402 and the above red lead.

The isolating choke may be added to the tuner filament circuit as follows:

1. Remove both brown leads from pin 3 of the 6AG5 mixer tube.
2. Solder them together, and insulate by a length of spaghetti.

3. Add an isolating choke, Part No. 32-4112-11, between pin 4 of the 6AG5 r-f-amplifier tube and pin 3 of the 6AG5 mixer tube. Make the choke leads as short as possible, and dress the choke away from other components.

### Regeneration When A-F-C Voltage Is Used for Alignment Indication

Under certain conditions, regeneration may result when the meter is connected to the a-f-c test jack for alignment indication. This may be avoided by using an isolating resistor in series with the prod end of the meter lead. The value of the resistor should be approximately 2000 ohms.

### Loss of A-G-C Action

An extremely black picture, and difficulty in synchronizing, may be caused by loss of a-g-c action. Whenever these symptoms occur, it is recommended that the a-g-c circuit is checked. In many cases, con-

duits, which increased the horizontal sync stability. The procedure for modifying these circuits in the early runs is given below. Figure 12 shows the modified circuits. The following parts are needed:

	Part No.
560-mm.f. condenser .....	60-10563307
680-mm.f. condenser .....	60-10685401
05-mf. condenser .....	61-0122
1-mf. condenser .....	60-0113
330-ohm resistor .....	66-1333340
1000-ohm resistor .....	66-2103340
2200-ohm resistor .....	66-2223340
18,000-ohm resistor .....	66-3183340
22,000-ohm resistor .....	66-3223340
100,000-ohm resistor .....	66-4103340
180,000-ohm resistor .....	66-4183340
33,000-ohm resistor .....	66-3333340
47,000-ohm resistor .....	66-3473340
25,000-ohm potentiometer .....	33-5539-28
Coil-and-condenser assembly, plate tank	32-4284
Terminal board .....	12W45660

ITEM NO.	DESCRIPTION OF CHANGE	PART ADDED	PART REMOVED
1	C519 changed to 560 mmf.	66-10515307	60-00515307
2	C518, .1 mf., removed		61-0113
3	C514B shunted by 1000 mmf.	30-1225	
4	R534 changed to 180,000 ohms	61-4183340	66-3823340
5	R535 changed to 18,000 ohms	66-3183340	66-2683340
6	C516 changed to 680 ohms	60-10685401	60-10825401

denser C322, which is connected between the triode plate and the diode plate of the a-g-c amplifier tube, will develop high-resistance leakage or a short, thus placing a positive voltage on the a-g-c bus, causing a loss of control of the r-f and i-f amplifiers. This condenser, if found to be defective, should be replaced with Part No. 61-0120, which is a .01-mf., 600-volt condenser.

### Correction for Vertical Black Line

A vertical black line, which usually shows up with no signal or a weak signal, may be caused by oscillation in the 6BG6G horizontal output stage.

This condition may be corrected by making the changes listed in the table above.

NOTE: These changes have been incorporated in Run 8 of Code 125.

### Modification of Horizontal Blocking Oscillator

In the later production runs of Model 48-1000, Codes 121 and 125, extensive changes were made in the horizontal-blocking-oscillator and discharge-tube cir-

Figure 16 shows the locations of terminal boards and tube sockets referred to in the following steps.

1. Remove all the wire connections from the 6SL7 (horizontal-sweep-generator tube) socket with the exception of the filament connections, pins 7 and 8.
2. Remove and discard the 820-mm.f. condenser connected between pin 5 of the 6SL7 socket and pin 6 of the 6K6 socket.
3. Remove and discard the 2200-ohm resistor connected between pins 6 and 7 of the 6K6 socket.
4. Remove and discard the 390,000-ohm resistor connected between pin 5 of the 6SL7 socket and terminal 4 of TB1.
5. Remove and discard the 820-mm.f. condenser connected between pin 1 of the 6SL7 socket and terminal 8 of TB5.
6. Remove and discard 560,000-ohm resistor connected between pin 1 of the 6SL7 socket and terminal 1 of TB1.
7. Remove and discard the 250,000-ohm potentiometer (control) and the connecting wires.

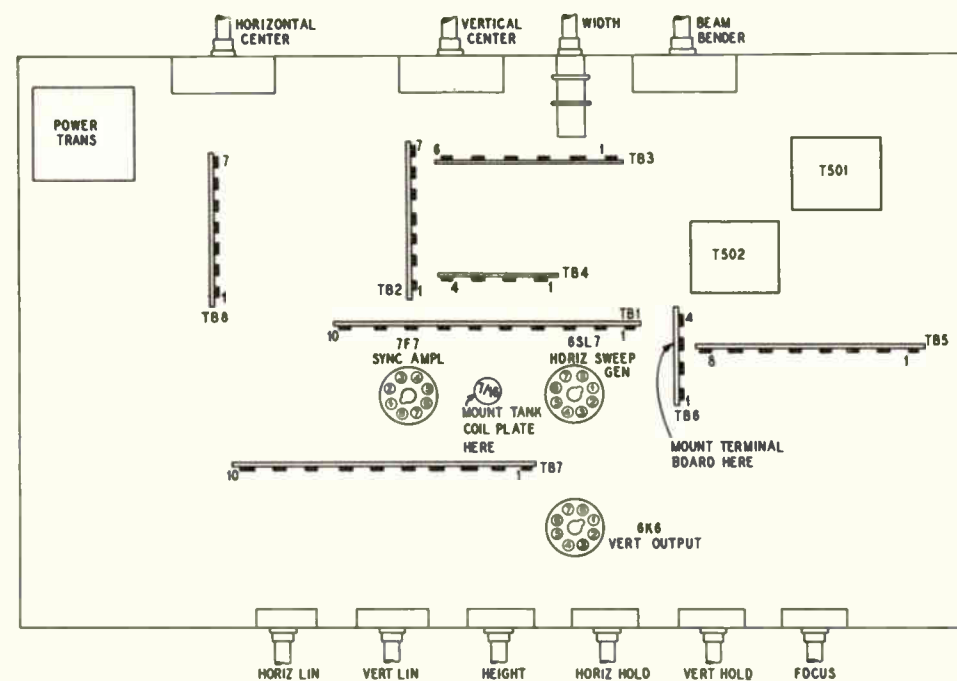

TP9-317

Figure 16. Terminal-Board Locations for Horizontal-Sweep Changes

8. Remove and save the 2200-ohm resistor connected between terminals 9 and 10 of TB1.
9. Remove and discard the 82,000-ohm and the 6800-ohm resistors connected between terminals 2, 3, and 5 of TB1.
10. Remove the 100,000-ohm resistor connected between terminals 5 and 6 of TB2.
11. Connect the blue lead of the horizontal-sweep-generator transformer (T502), formerly connected to pin 2 of the 6SL7 socket, to pin 5 of the 6SL7 socket.
12. Remove the green lead of the horizontal-sweep-generator transformer from terminal 8 of TB5, and connect it to pin 1 of the 6SL7 socket.
13. Remove the red lead of the horizontal-sweep-generator transformer from terminal 5 of TB2, and connect it to terminal 1 of TB1.
14. Connect an 18,000-ohm resistor between terminals 3 and 2 of TB1.
15. Connect a 180,000-ohm resistor between terminals 3 and 5 of TB1.
16. Connect the end of the .01-mf. condenser, formerly connected to pin 5 of the 6SL7 socket, to terminal 1 of TB1.
17. Connect a 100,000-ohm resistor between terminals 1 and 4 of TB1.
18. Connect a 330,000-ohm resistor between terminals 9 and 10 of TB1.
19. Connect a 680-mm.f. condenser between terminal 1 of TB1 and terminal 8 of TB5.
20. Connect a .05-mf. condenser between terminals 2 and 4 of TB1.
21. Connect a 22,000-ohm resistor between terminals 6 and 4 of TB2.
22. Install a 25,000-ohm potentiometer in place of the 250,000-ohm potentiometer previously removed.
23. Connect a 33,000-ohm resistor from one side of the 25,000-ohm potentiometer to ground.
24. Mount a terminal board, identified as TB6 in figure 16, on the chassis. (The hole in the chassis between the 6SL7 tube and the filter condenser can be conveniently used for mounting the terminal board.)
25. Connect a 2200-ohm resistor between pin 2 of the 6SL7 socket and terminal 3 of TB6.
26. Connect a 1000-ohm resistor between pin 3 of the 6SL7 socket and terminal 2 of TB6.
27. Connect a 560-mm.f. condenser between pin 2 of the 6SL7 socket and terminal 3 of TB6.
28. Connect a wire between pin 6 of the 6SL7 socket and terminal 3 of TB6.
29. Connect a wire between terminal 3 of TB6 and the center of the 25,000-ohm potentiometer.
30. Connect a 1-mf. condenser between pin 3 of the 6SL7 socket and terminal 1 of TB7.
31. Mount the tuned plate tank on the chassis with the adjusting screw protruding upward. This step will necessitate drilling a 7/16" hole in the chassis. The hole should be located between the 6SL7 horizontal-sweep-generator tube and the 7F8 sync amplifier tube. See figure 16.

32. Connect the red lead of the tank circuit to terminal 3 of TB6.
33. Connect the blue lead of the tank circuit to terminal 1 of TB6.
34. Connect a wire between pins 8 and 3 of the 6SL7 socket.
35. Remove the 100,000-ohm resistor that is connected between terminals 4 and 3 of TB8, and replace it with a 47,000-ohm resistor.

### Background Control Ineffective

Under certain operating conditions, the 390,000-ohm, 1/2-watt resistor connected between B+ and the background control increases in value to a point where the background control becomes ineffective. It is recommended that this resistor, R434, be replaced by a 1-watt resistor of the same value, Part No. 66-4394340, whenever the chassis is handled for any service reason.

### Electrical Focus System Replacements in Model 48-1000, Code 121

The focus coil for the Model 48-1000, Code 121, is no longer stocked by the Accessory Division. The high-resistance focus coil used in this model and code may be replaced if all the components are replaced (focus coil, focus control) with the corresponding low-resistance focus components, i. e., focus-coil assembly Part No. 76-2622-2 and focus control Part No. 33-5547-2.

Refer to the schematic diagram and figure 17, and use the following procedure:

1. Remove the old focus coil, L502, Part No. 76-2622.
2. Add the new focus coil, Part No. 76-2622-2, and

- connect the leads to the outside terminals of the terminal panel on the cradle.
3. Remove resistor R545 and the old focus control, R546.
4. Connect a wire from the terminal connection that formerly held R545 and the wire from R546 to pin 5 of J500.
5. Install the new-type focus control, Part No. 33-5547-2, and reconnect the wires as before.
6. Remove the wire connection between R524 and R525 at the R525 end. Reconnect this wire to pin 7 of J500.

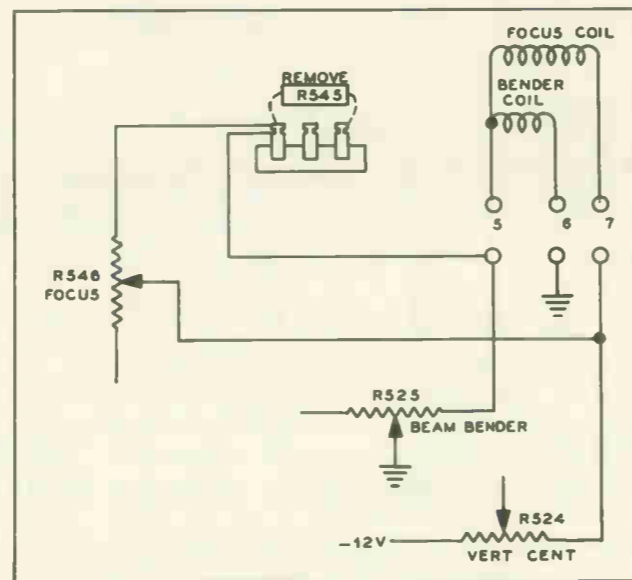

TP9-318

Figure 17. Focus-Coil Replacement

## SERVICE HINTS

### Prevention of High-Voltage-Component Failures

Under certain conditions, with the Receiver operating, if the high-voltage-anode connector is grounded, or if there is a flash-over in the projection tube, it is possible for the width coil to be burned out (or even the horizontal output transformer, deflection yoke or horizontal centering control). In most cases, the width coil will burn out first.

It is recommended that, whenever a 48-2500 chassis is being serviced, a 470,000 ohm, one-watt resistor, Part No. 66-4474340 be added, at the high-voltage socket, in series with the second anode lead. This resistor should be wired from pin 2 to pin 6 of the socket farthest from the high-voltage transformer. The anode lead should be removed from pin 7 and connected to pin 6.

### Loss of A-G-C Action

An extremely black picture, and difficulty in synchronizing, may be caused by loss of a-g-c action. Whenever these symptoms occur, it is recommended that the a-g-c circuit be checked. In many cases, condenser C322, which is connected between the triode plate and the diode plate of the a-g-c amplifier tube, will develop high-resistance leakage or a short, thus placing a positive voltage on the a-g-c bus, causing a loss of control of the r-f and i-f amplifiers. This condenser, if found to be defective, should be replaced with Part No. 61-0120, which is a .01-mf., 600-volt condenser.

## COLOR CODING OF MOLDED TUBULAR PAPER CONDENSERS

Molded tubular paper condensers are color-coded as shown in figure 36 and explained below:

The nominal capacitance value, in micromicrofarads, is identified by the first three bands on the

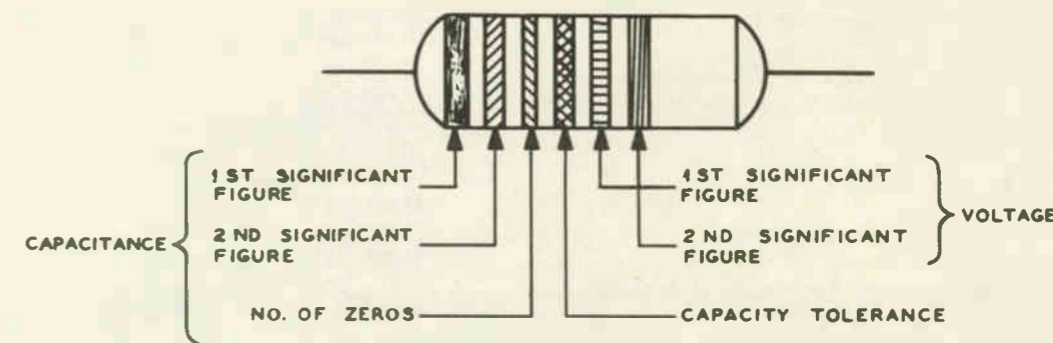

TP-9813

Figure 36. Molded Tubular Paper Condenser, Showing Placement of Code Bands

COLOR	SIGNIFICANT FIGURE	NO. OF ZEROS FOLLOWING DIGITS IN CAPACITANCE VALUE	CAPACITY TOLERANCE
Black	0		±20%
Brown	1	0	
Red	2	00	
Orange	3	000	±30%
Yellow	4	0000	±40%
Green	5	00000	±5%
Blue	6	000000	
Violet	7		
Gray	8		
White	9		±10%

condenser. The first two bands indicate the significant figure for the first and second digits of the capacitance value, and the third band indicates the number of zeros following the two digits.

The capacity tolerance is identified by the fourth band.

The voltage rating is identified by the fifth band for ratings through 900 volts, and by the fifth and sixth bands for ratings above 900 volts.

For a voltage rating of 900 volts or less, the fifth band indicates the significant figure for the first digit of the voltage rating.

For voltage ratings over 900 volts, the fifth and sixth bands indicate the significant figures for the first and second digits, respectively, of the voltage rating. In either case, two zeros are understood to follow the digits. Condensers having a voltage rating of 900 volts or less have only five bands.

Figure 37 gives an example of color-coding interpretation.

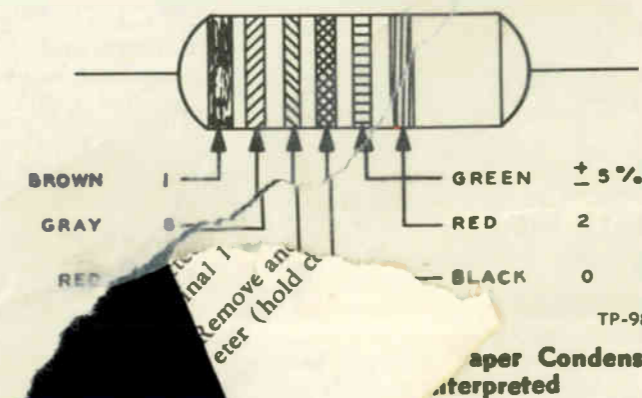

TP-9814

Figure 37. Molded Tubular Paper Condenser, Color-Coding Interpreted



PRODUCTION CHANGES—Code 121

ITEM NO.	DESCRIPTION OF CHANGE	FIGURES OF PR-1103 AFFECTED	CHANGE EFFECTIVE	NEW OR ADDED PART NO.	OLD OR REMOVED PART NO.	REASON
1	R419 removed.	17. 27	Run 2		66-3478540	To allow test-signal input at J401.
2	.004-mf. by-pass condenser (C427) added at B+ end of R403.	17. 27	Run 2	61-0179*		To reduce v-i-f oscillation.
3	10-mmf. by-pass condenser (C428) added parallel to C406.	17. 27	Run 2	62-010009001		To reduce v-i-f oscillation.
4	R523 removed.	19. 27	Run 2		66-2105340	To improve vertical sweep.
5	C510 removed.	19. 27	Run 2		30-2417-6	To improve vertical sweep.
6	10-mf. condenser (C320) added at plate end of R305.	15. 27	Run 2	30-2417-6		To prevent motorboating on high channels.
7	470-mmf. condenser (C321) added at pin 4 of r-f amplifier.	15. 27	Run 2	62-147001001		To prevent motorboating on high channels.
8	30-mf. condenser (C106) added parallel to C102.	21. 27	Run 3	30-2568-9		To reduce operating temperature of C102.
9	R201 changed to 47,000 ohms.	18. 27	Run 4	66-3473340	66-4228540	To improve a-i-f response.
10	Two 100,000-ohm screen resistors (R222 and R223) added at first and second a-i-f tubes.	18. 27	Run 4	66-4108540 (each)		To improve a-i-f response.
11	R202 changed to 150 ohms.	18. 27	Run 4	66-1153340	66-0683350	To improve a-i-f response.
12	R206 changed to 220 ohms.	18. 27	Run 4	66-1228340	66-1158340	To improve a-i-f response.
13	C207 changed to .004 mf.	18. 27	Run 4	61-0179*	62-147001001	To improve a-i-f response.
14	Discriminator filament choke (L205) added at pin 4 of discriminator.	18. 27	Run 6 and 7	32-4112-4		To reduce harmonic beat.
15	Z401 changed.	17. 27	Run 6 and 7	32-4213	32-4094	Slug tuning to aid in alignment.
16	Z402 changed.	17. 27	Run 6 and 7	32-4213-1	32-4094-1	Slug tuning to aid in alignment.
17	L503 changed.	19. 27	Run 6 and 7	32-4163-2	32-4163-1	To improve width adjustment.
18	Z202 changed.	18. 27	Run 6 and 7	32-4214	32-4101-1	To improve a-i-f stability.
19	5-mmf. condenser (C223) added at pin 2 of 2nd a-i-f tube.	18. 27	Run 6 and 7	32-1224-5		To improve a-i-f stability.
20	T503 changed.	19. 27	Run 6 and 7	32-8331	32-8305	To reduce high-voltage breakdown.
21	R528 rewired as in figure 12.	19. 26. 27	Run 6 and 7	No change		To improve horizontal-sync stability.
22	R529 changed to 330,000 ohms.	19. 26. 27	Run 6 and 7	66-4333340*	66-4103340*	To improve horizontal-sync stability.
23	R530 changed to 220 ohms.	19. 26. 27	Run 6 and 7	66-1223340*	66-2223340*	To improve horizontal-sync stability.
24	R531 changed to 33,000 ohms and rewired as in figure 12.	19. 26. 27	Run 6 and 7	66-3333340*	66-4563340*	To improve horizontal-sync stability.
25	R532 changed to 25,000 pot. and rewired as in figure 12.	19. 26. 27	Run 6 and 7	33-5539-28	33-5539-13	To improve horizontal-sync stability.
26	R533 changed to 100,000 ohms and rewired as in figure 12.	19. 26. 27	Run 6 and 7	66-4103340*	66-4393340*	To improve horizontal-sync stability.
27	R549 changed to 1800 ohms.	19. 26. 27	Run 6 and 7	66-2183340*	66-2223340*	To improve horizontal-sync stability.

PRODUCTION CHANGES—Code 121 (Cont.)

ITEM NO.	DESCRIPTION OF CHANGE	FIGURES OF PR-1103 AFFECTED	CHANGE EFFECTIVE	NEW OR ADDED PART NO.	OLD OR REMOVED PART NO.	REASON
28	R550, 560,000 ohms, added as in figure 12.	19. 26. 27	Run 6 and 7	66-4563340*		To improve horizontal-sync stability.
29	R551, 1000 ohms, added as in figure 12.	19. 26. 27	Run 6 and 7	66-2103340*		To improve horizontal-sync stability.
30	R552, 2200 ohms, added as in figure 12.	19. 26. 27	Run 6 and 7	66-2223340*		To improve horizontal-sync stability.
31	C514A rewired as in figure 12.	19. 26. 27	Run 6 and 7	No change		To improve horizontal-sync stability.
32	C515 changed to .1 mf. and rewired as in figure 12.	19. 26. 27	Run 6 and 7	61-0113*	60-10825401*	To improve horizontal-sync stability.
33	C516 changed to 680 mmf. and rewired as in figure 12.	19. 26. 27	Run 6 and 7	60-10685401*	60-10825401*	To improve horizontal-sync stability.
34	C517 rewired as in figure 12.	19. 26. 27	Run 6 and 7	No change		To improve horizontal-sync stability.
35	C523, 2000 mmf., added as in figure 12.	19. 26. 27	Run 6 and 7	60-20205304*		To improve horizontal-sync stability.
36	C524, 560 mmf., added as in figure 12.	19. 26. 27	Run 6 and 7	60-10565314*		To improve horizontal-sync stability.
37	L504, 60 mh., added as in figure 12.	19. 26. 27	Run 6 and 7	32-4256		To improve horizontal-sync stability.
38	Wiring panel, four-point added on bottom of chassis, parallel to sides of chassis, between vertical output (6K6GT) socket and C506.	19. 26. 27	Run 6 and 7	12W45661		To improve horizontal-sync stability.
39	R505 changed to 47,000 ohms.	19. 26. 27	Run 6 and 7	66-3473340*	66-4473340*	To improve horizontal-sync stability.

CHANGES IN PRODUCTION FROM RUN 4 OF CODE 121 TO RUN 1 OF CODE 125

1	R443 changed to 100,000 ohms.	17. 27	Run 1	66-4108540	66-5103340	To increase a-v-c stability.
2	R415 changed to 470,000 ohms.	17. 27	Run 1	66-4473340	66-5473340	To increase a-v-c stability.
3	R203 changed to 100,000 ohms.	18. 27	Run 1	66-4108540	66-3473340	To improve a-i-f performance.
4	R207 changed to 100,000 ohms.	18. 27	Run 1	66-4108540	66-3273340	To improve a-i-f performance.
5	L502 changed.	19. 27	Run 1	76-2622-2	76-2622	To improve focus. See figure 13.
6	R546 changed.	19. 27	Run 1	33-5547-2	33-5546-5	To improve focus. See figure 13.
7	L502 changed.	19. 27	Run 1	76-2622-1	76-2622	To improve focus. See figure 13.
8	R525 changed	19. 27	Run 1	33-5546-4	33-5546-2	To improve focus. See figure 13.
9	R545 removed.	19. 27	Run 1		66-3105340	To improve focus. See figure 13.

PRODUCTION CHANGES—Code 125

ITEM NO.	DESCRIPTION OF CHANGE	FIGURES OF PR-1103 AFFECTED	CHANGE EFFECTIVE	NEW OR ADDED PART NO.	OLD OR REMOVED PART NO.	REASON
1	Discriminator filament choke (L205) added at pin 4 of discriminator.	18, 27	Run 2	32-4112-4*		To reduce harmonic beat.
2	Z401 changed.	17, 27	Run 2	32-4213	32-4094	Slug tuning to aid in alignment.
3	Z402 changed.	17, 27	Run 2	32-4213-1	32-4094-1	Slug tuning to aid in alignment.
4	L503 changed.	19, 27	Run 3	32-4163-2	32-4163-1	To improve width adjustment.
5	Z202 changed.	18, 27	Run 4	32-4214	32-4101-1	To improve a-i-f stability.
6	5-mm.f. condenser (C223) added at pin 2 of 2nd a-i-f tube.	18, 27	Run 4	32-1224-5		To improve a-i-f stability.
7	L503 changed.	19, 27	Run 5	32-4163	32-4163-2	To improve width adjustment.
8	T503 changed.	19, 27	Run 5	32-8331	32-8305	To reduce high-voltage breakdown.
9	L503 changed.	19, 27	Run 6	32-4163-2	32-4163	
10	R528 rewired as in figure 12.	19, 26, 27	Run 7	No change		To improve horizontal-sync stability.
11	R529 changed to 330,000 ohms.	19, 26, 27	Run 7	66-4333340*	66-4103340*	To improve horizontal-sync stability.
12	R530 changed to 220 ohms.	19, 26, 27	Run 7	66-1223340*	66-2223340*	To improve horizontal-sync stability.
13	R531 changed to 33,000 ohms and rewired as in figure 12.	19, 26, 27	Run 7	66-3333340*	66-4563340*	To improve horizontal-sync stability.
14	R532 changed to 25,000 pot. and rewired as in figure 12.	19, 26, 27	Run 7	33-5539-28	33-5539-13	To improve horizontal-sync stability.
15	R533 changed to 100,000 ohms and rewired as in figure 12.	19, 26, 27	Run 7	66-4103340*	66-4393340*	To improve horizontal-sync stability.
16	R549 changed to 1800 ohms.	19, 26, 27	Run 7	66-2183340*	66-2223340*	To improve horizontal-sync stability.
17	R550, 560,000 ohms, added as in figure 12.	19, 26, 27	Run 7	66-4563340*		To improve horizontal-sync stability.
18	R551, 1000 ohms, added as in figure 12.	19, 26, 27	Run 7	66-2103340*		To improve horizontal-sync stability.
19	R552, 2200 ohms, added as in figure 12.	19, 26, 27	Run 7	66-2223340*		To improve horizontal-sync stability.
20	C514A rewired as in figure 12.	19, 26, 27	Run 7	No change		To improve horizontal-sync stability.
21	C515 changed to .1 mf. and rewired as in figure 12.	19, 26, 27	Run 7	61-0113*	60-10825401*	To improve horizontal-sync stability.
22	C516 changed to 680 mmf. and rewired as in figure 12.	19, 26, 27	Run 7	60-10685401*	60-10825401*	To improve horizontal-sync stability.
23	C517 rewired as in figure 12.	19, 26, 27	Run 7	No change		To improve horizontal-sync stability.
24	C523, 2000 mmf., added as in figure 12.	19, 26, 27	Run 7	60-20205304*		To improve horizontal-sync stability.
25	C524, 560 mmf., added as in figure 12.	19, 26, 27	Run 7	60-10565314*		To improve horizontal-sync stability.

PRODUCTION CHANGES—Code 125 (Cont.)

ITEM NO.	DESCRIPTION OF CHANGE	FIGURES OF PR-1103 AFFECTED	CHANGE EFFECTIVE	NEW OR ADDED PART NO.	OLD OR REMOVED PART NO.	REASON
26	L504, 60 mh., added as in figure 12.	19, 26, 27	Run 7	32-4256		To improve horizontal-sync stability.
27	Wiring panel, four-point, added on bottom of chassis parallel to sides of chassis, between vertical-output (6K6GT) socket and C506.	19, 26, 27	Run 7	12W45661		To improve horizontal-sync stability.
28	R505 changed to 47,000 ohms.	19, 26, 27	Run 7	66-3473340*	66-4473340*	To improve horizontal-sync stability.
29	R529 changed to 150,000 ohms.	19, 26, 27	Run 8	66-4154340	66-4333340	To remove vertical black line.
30	R550 removed. See Note.	19, 26, 27	Run 8		66-4563340	To remove vertical black line.
31	R535 changed to 180,000 ohms.	19, 26, 27	Run 8	66-4183340	66-2683340	To remove vertical black line.
32	R435 changed to 18,000 ohms.	19, 26, 27	Run 8	66-3183340	66-3823340	To remove vertical black line.
33	R549 changed to 1,000 ohms.	19, 26, 27	Run 8	66-2103340	66-2183340	To remove vertical black line.
34	R533 changed to 22,000 ohms.	19, 26, 27	Run 8	66-3223340	66-4103340	To improve horizontal-sync stability.
35	R530 changed to 330 ohms.	19, 26, 27	Run 8	66-1333340	66-1223340	To improve horizontal-sync stability.
36	C525, 560 mmf., added from pin 3 of 6B6G to ground.	19, 26, 27	Run 8	60-10565414		To remove vertical black line.

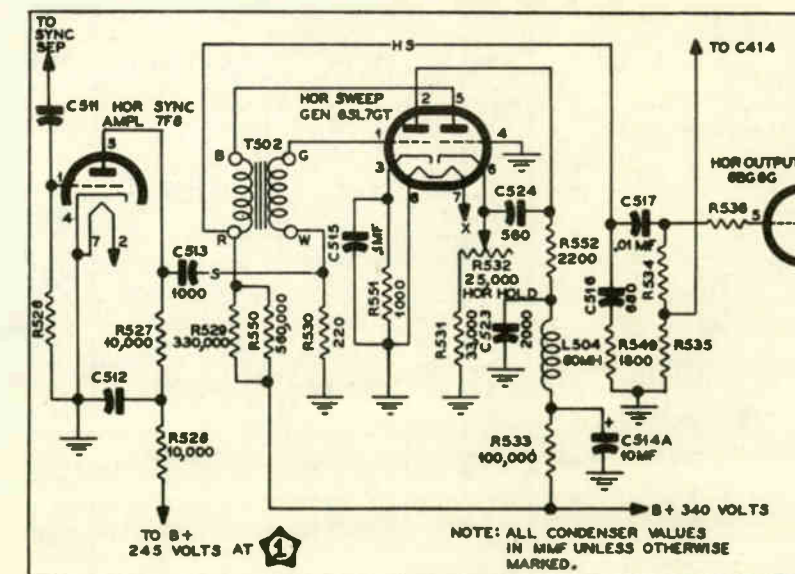

TP-4087A

Figure 12. Horizontal-Sweep Changes

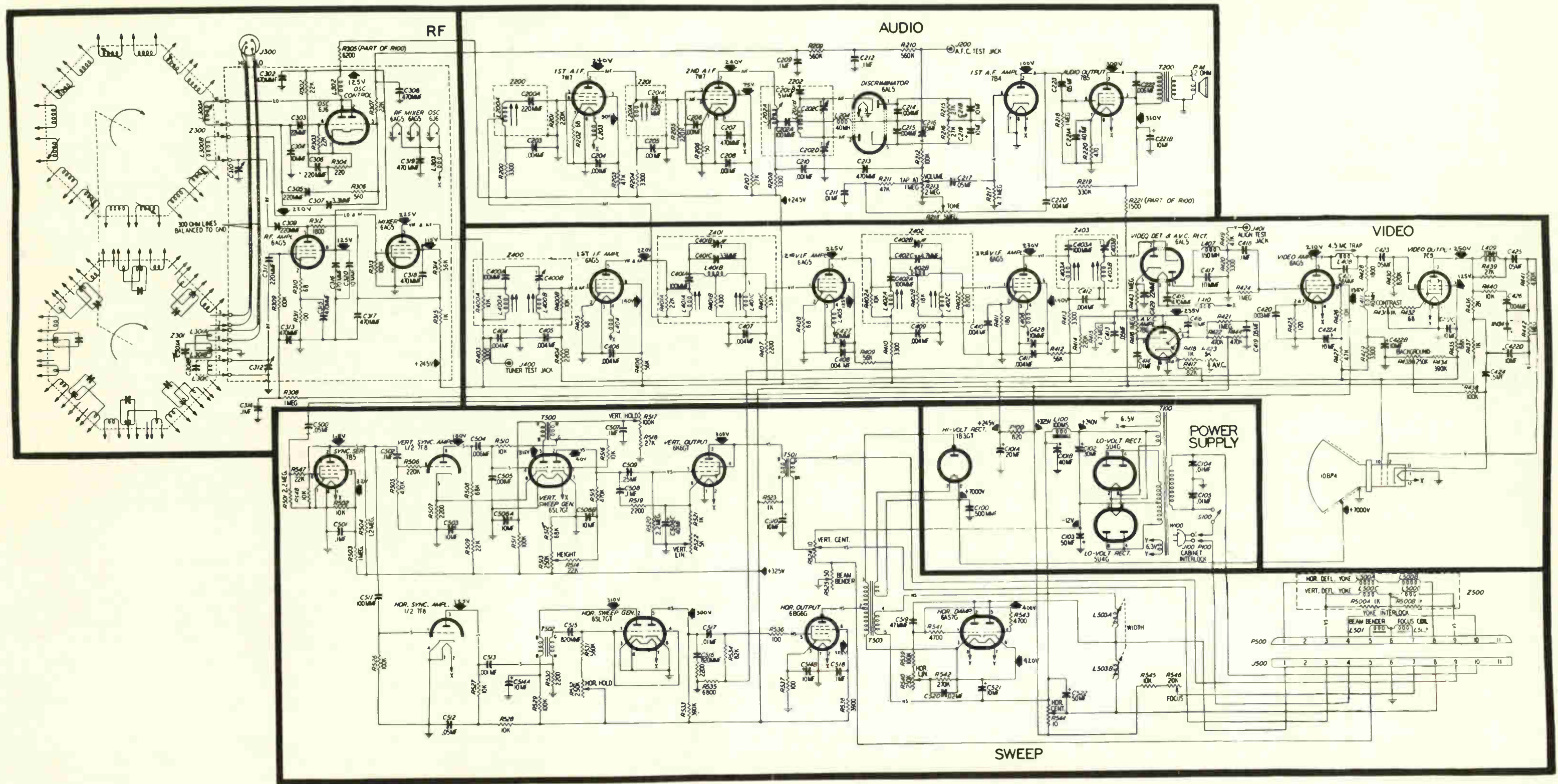

Figure 10. Philco Television Receiver Model 48-1000, Codes 121 and 125, Sectionalized Schematic Diagram

## PRODUCTION CHANGES

Run No.	Description of Change	New or Added Part No.	Old or Removed Part No.	Reason for Change
2	C500 changed to .047 mf**	61-0122	61-0122	Standardization of parts.
	R505 changed from 1/2 watt to 1 watt.	66-5104340	66-5103540	To improve stability.
3	R534 changed to 22,000 ohms.	66-3223340	66-4103540	To increase sync stability.
	R510 changed to 82,000 ohms.	66-3823340	66-3683340	To improve vertical sync.
4	R219 added. 3300 ohms.	66-2333340		To reduce harmonic beat, and improve FM-AM ratio. (See figure 12.)
5	R220 added. 10,000 ohms.	66-3103340		
	R221 added. 2200 ohms.	66-2223340		
	R222 added. 1000 ohms.	66-2103340		
6	R543 and R544 replaced by a single resistor of 6200 ohms.	33-1335-19	33-1335-74 33-1335-75	To improve performance.
7	R205 replaced by a 40-millihenry choke.	32-4143-1	66-4223340	To improve stability of a.i.t., and reduce interference caused by harmonic beats.
	R222, which was added in runs 4 and 5, was replaced by a 40-millihenry choke.	32-4143-1	66-2103340	
8	R529 changed to 330 ohms.	66-1333340	66-1223340	To improve horizontal sync stability.
9	R535 removed, and C517 grounded.		66-2183340	To reduce transient oscillation within horizontal ampl.
	R536 changed to 18,000 ohms.	66-3183340	66-2683340	
	R537 changed to 180,000 ohms.	66-4183340	66-3823340	
	C520 changed to .08 mf.	45-3501	61-0113340	
	C519 removed.		61-0113340	
	C521 removed.		61-0188	
	680-mmf. condenser added, from cathode (pin 3) of horizontal output tube (6BG6G) to ground.	60-10685401		

\*\* Substitute a .05-mf. condenser, Part No. 61-0122, for replacement purposes.

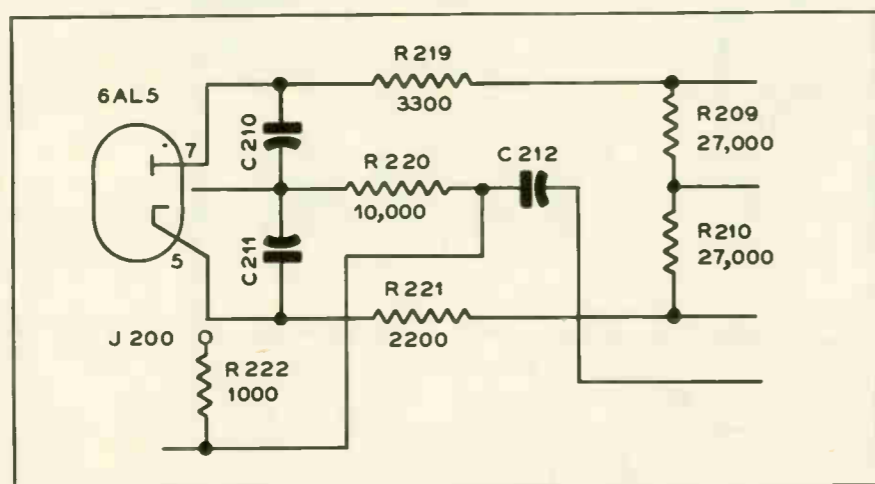

Figure 12. Discriminator Circuit Changes in Runs 4 and 5

TP-5394

## SERVICE HINTS

### Harmonic Beat Interference

Beat patterns may appear in the picture when operating on Channel 7; less frequently on Channels 4 and 11. This condition may be corrected by adding compensating and filter resistors to the FM discriminator

circuit, as shown in the revised schematic, figure 13, and the layout drawing, figure 14.

It is recommended that the following changes be made when the chassis are serviced, or when Channels 4, 7, or 11 are adjusted for reception.

- Remove the following parts carefully, as they are to be reinstalled.
  - C218, connected between pin 5 of the discriminator tube (6AL5) and ground.
  - C219, connected between pin 7 of the discriminator and ground.
  - R215, connected between pin 5 of the discriminator and ground.
  - R216, connected between pin 7 of the discriminator and terminal 3 of terminal board TB6.
  - Length of wire, connected between terminal 1 of terminal board TB3 and socket J200.

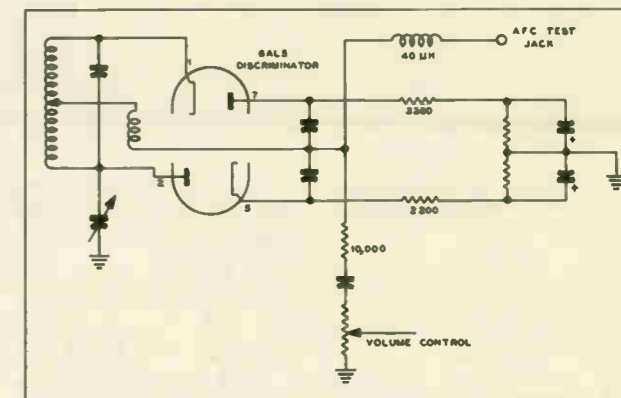

TP9-316

Figure 13. Revised Discriminator Schematic

- Install a wiring panel, Part No. 12W45661, at the location indicated by TB4 in figure 14. Note how the terminals are numbered, and make sure that the number 3 terminal is used as the mounting foot.
- Connect the 27,000-ohm resistor R215 between terminals 2 and 4 of TB4, as shown in figure 14.
- Connect the 27,000-ohm resistor R216 between terminals 1 and 4 of TB4.
- Connect a bare wire jumper between terminals 3 and 4 of TB4.
- Connect the 10-mf. condenser C218 between terminals 2 and 4 of TB4 (positive lead to terminal 2).
- Connect the 10-mf. condenser C219 between terminals 1 and 4 of TB4 (positive lead to terminal 4).
- Connect a 40-microhenry choke, Part No. 32-4143-1, between terminals 1 and 3 of TB3. (If terminal 3 is already in use, connect to any nearby vacant terminal.)
- Connect a 3300-ohm, 1/2 watt, 10% resistor, Part No. 66-2338340, from pin 7 of the discriminator to terminal 1 of TB4.
- Connect a 2200-ohm, 1/2 watt, 10% resistor, Part No. 66-2228340, from pin 5 of the discriminator to terminal 2 of TB4.
- Connect a length of white wire from socket J200 to terminal 1 of TB3. (If some other terminal was used in step 8, use the same terminal for this connection.)
- Remove the green wire from terminal 2 of TB6, and connect it to terminal 1 of TB6.
- Connect a 10,000-ohm, 1/2 watt, 10% resistor, Part No. 66-3108540, between terminals 1 and 2 of TB6.

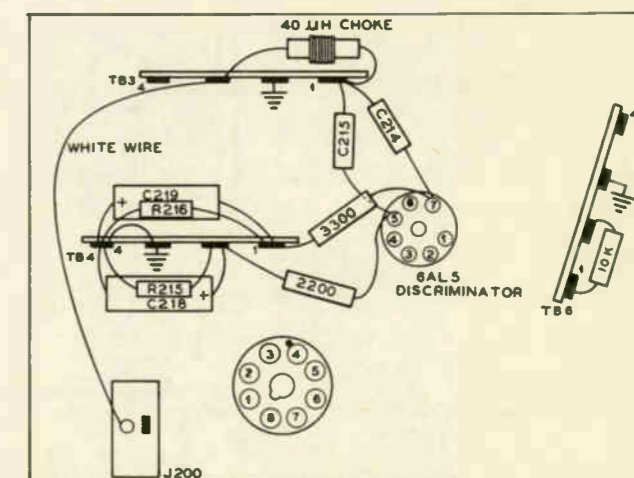

TP9-315

Figure 14. Bottom View of Parts Layout in Discriminator Change

- Solder them together, and insulate by a piece of spaghetti.
- Add a choke, Part No. 32-4112-11, between pin 4 of the r-f-amplifier tube (6AG5) and pin 3 of the mixer tube. Make the choke leads as short as possible, and dress the choke away from other components.

### Microphonics on High-Frequency Channel

Low-frequency microphonics may be encountered, and are particularly noticeable on Channel 9. This effect may be reduced by making the following changes:

- Remove both brown wires from pin 3 of the mixer tube (6AG5).

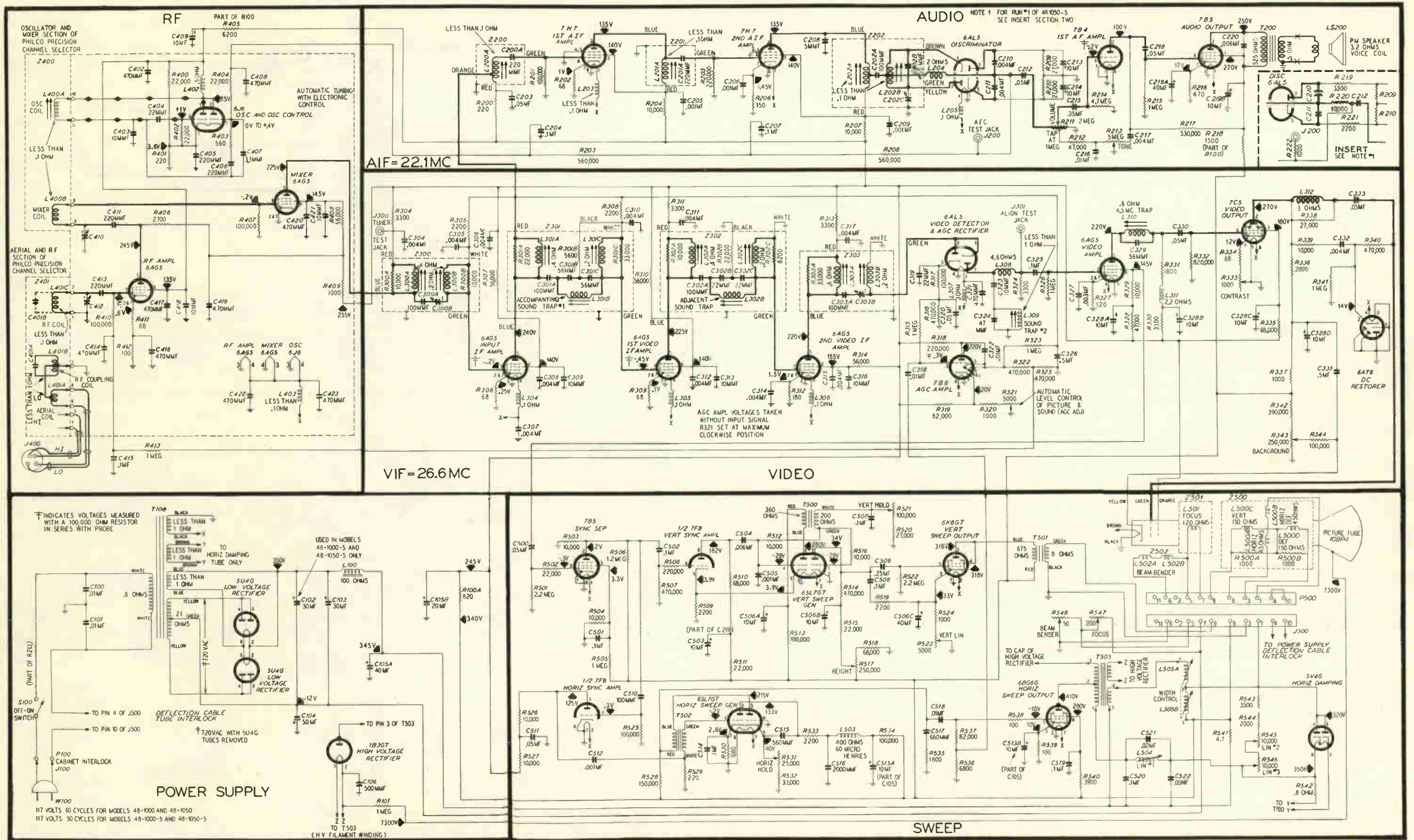

Figure 10. Philco Television Receiver Models 48-1000, 48-1000-5, 48-1050, and 48-1050-5, all Code 122, Sectionalized Schematic Diagram

## PRODUCTION CHANGES

The following production changes were made since the printing of PR-1542 (Philco Service Manual Supplement, for Model 48-1001, Code 121).

All Model 48-1001 television receivers are Code 121 unless a different code number is stamped next to the model number on the rear of the chassis.

### CODE 121

#### Run 5

Z202, discriminator transformer, Part No. 32-4214, was replaced by Part No. 32-4214-3, to reduce frequency drift.

#### Run 6

R547, Part No. 33-5547-2, was replaced by Part No. 33-5546-12. (Change of rating.)

#### Run 7

To reduce modulation hum on high-frequency channels, a choke, Part No. 32-4112-2, was added, between the junction of R400, C402, L402 and the junction of C409, R405.

#### Run 8

The width coil, L505, Part No. 32-4163-2, was replaced by a new width coil, Part No. 32-4318. In conjunction with this new coil, a bracket-and-panel assembly, Part No. 76-4239 (symbolized TB500), was added. This assembly is mounted vertically in the left rear corner, inside the cage containing the high-voltage assembly.

To obtain maximum width, set the link in a downward position; this shorts part of the series winding (see figure 4). The tuning core, TC500, then acts as a vernier for fine adjustment.

#### Run 9

Due to a temporary shortage of the properly rated resistors (10,000 ohms) for R204 and R207, Part No. 66-3105340, a substitution for each was made by using two pairs of 22,000-ohm resistors (parallel-connected). The part number for each 22,000-ohm resistor is 66-3224340.

### CODE 122

This code is similar to Code 11 (including Runs 1 through 9) except for the following changes:

#### Section 1

The a-c power line was connected directly to transformer T100 instead of to pins 4 and 10 of the a-c interlock.

#### Section 2 (see figure 3)

1. Z202 was replaced by a new discriminator transformer, Part No. 32-4317.

2. L204, choke, balancing, Part No. 32-4143-1, was removed.
3. The 5-mmF. condenser, connected from the plate of the 2nd a-i-f tube (7H7) to ground, was removed.
4. Condenser C208, .001 mf., Part No. 45-3500-5\*, was added, between pin 3 of the 2nd a-i-f tube and ground.
5. L202C, part of Z202, was added.
6. C202A, condenser, coupling, 100 mmF., part of Z202, was removed.
7. C202C, condenser, balancing, part of Z202, was removed.
8. C202B, 10 mmF., part of Z202, was changed to 20 mmF., and resymbolized C202A.
9. C206, .001 mf., Part of No. 45-3500-5\*, was removed from the cathode (pin 7) of the 2nd a-i-f tube, and connected as shown in figure 3.
10. R222, 47,000 ohms, Part No. 66-3473340\*, was added. See figure 3.
11. R223, 47 ohms, Part No. 66-0473340\*, was added. See figure 3.
12. R219, 3300 ohms, Part No. 66-2333340, was changed to 1200 ohms, Part No. 66-2123340.
13. R209, 27,000 ohms, Part No. 66-3273340\*, was changed to 10,000 ohms, Part No. 66-3103340\*.
14. R210, 27,000 ohms, Part No. 66-3273340\*, was changed to 10,000 ohms, Part No. 66-3103340\*.

#### Section 5 (see figure 4)

1. C509, condenser, coupling, .25 mf., Part No. 61-0125\*, was changed to .1 mf., Part No. 61-0113\*.
2. The connection of the vertical deflection yoke, P9 and P3, were changed to 4 and 5, respectively.
3. R549, resistor, linearity-control limiting, 6200 ohms, was changed to 33,000 ohms, Part No. 66-3333340\*.
4. R545 and R546, horizontal linearity controls No. 2 and No. 3 were removed. The circuit was rewired as shown in figure 4.
5. R548, beam-bender control, was removed.
6. Z502, beam-bender-coil assembly (including L502A and L502B) was removed.
7. A permanent-magnet type of beam bender (BB500), Part No. 76-3913, was added.
8. J500, receptacle, chassis (deflection-yoke-cable connector) 11 pins, Part No. 27-6229, was changed to 8 pins, Part No. 27-6174-4.
9. P500, deflection-yoke-plug connector and cable, 11 pins, Part No. 41-3764-1, was changed to 8 pins, Part No. 41-3860.

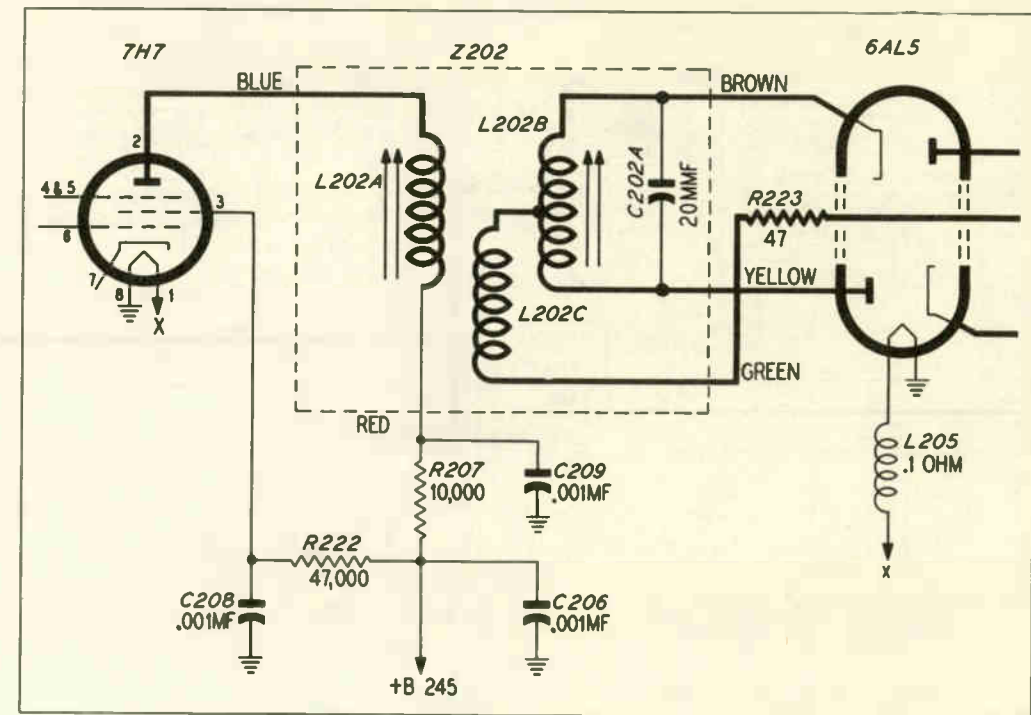

TP-5687

Figure 3. New Discriminator Transformer and Associated Circuit

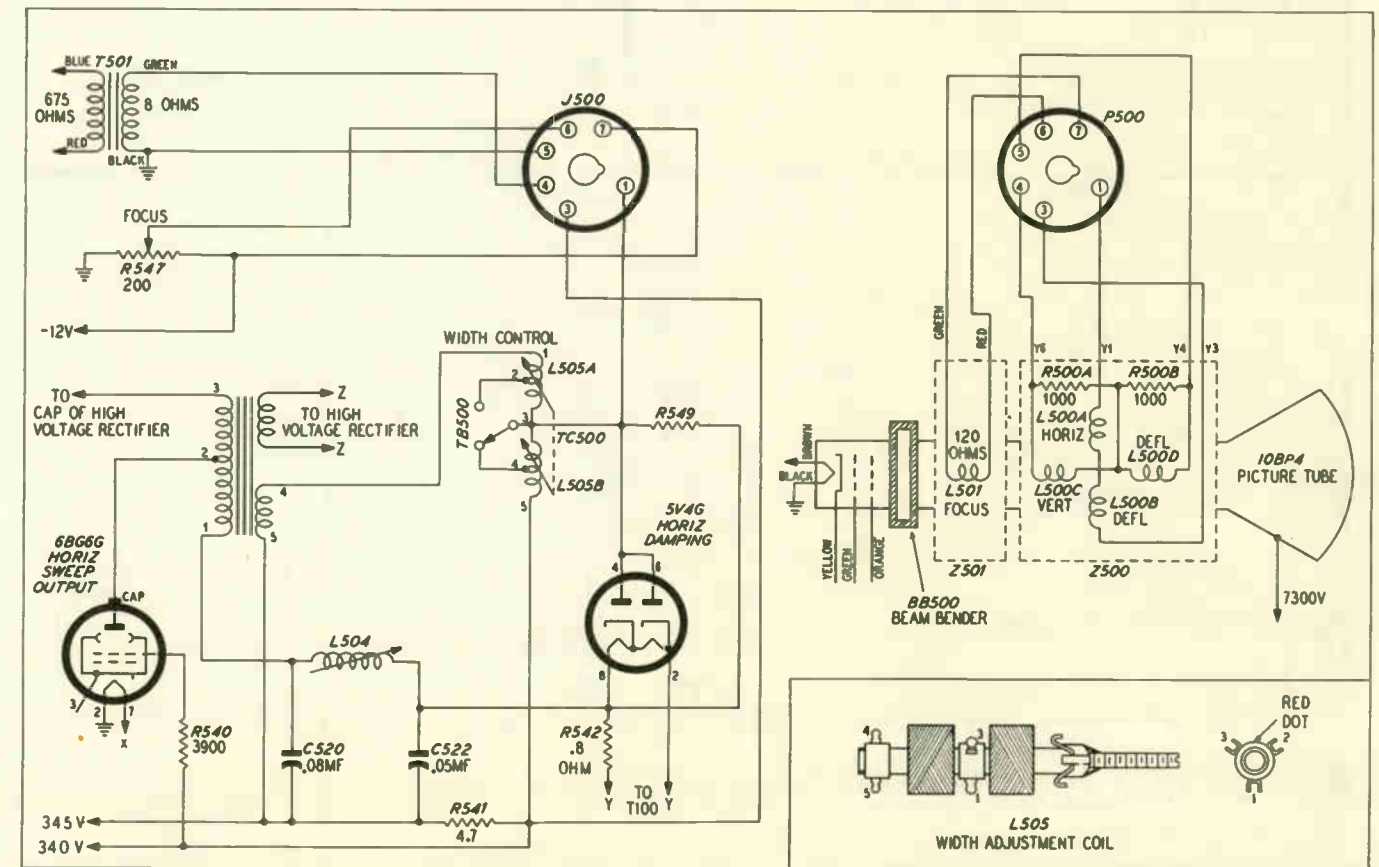

TP-5687A

Figure 4. Changes in Output Circuit

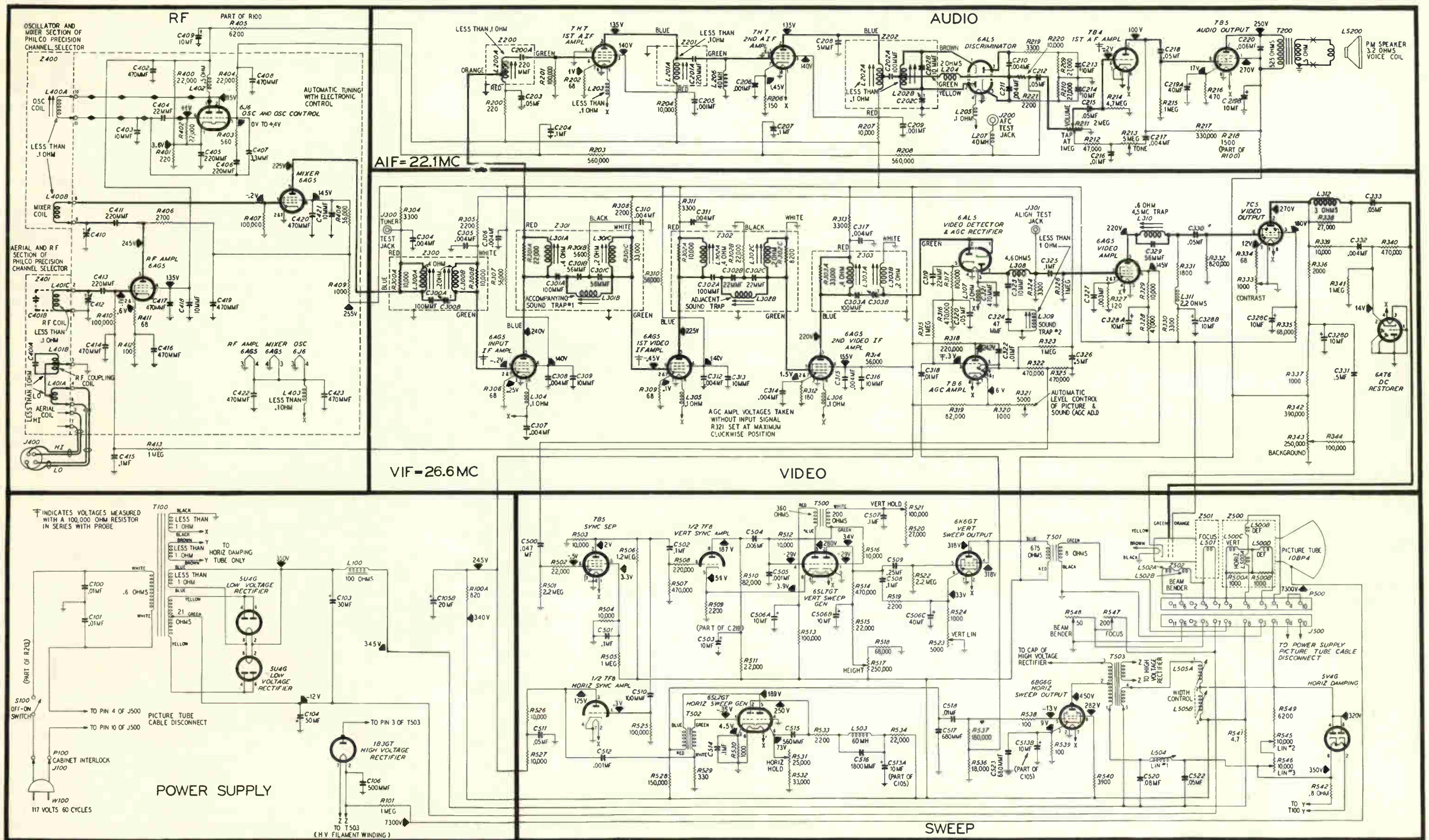
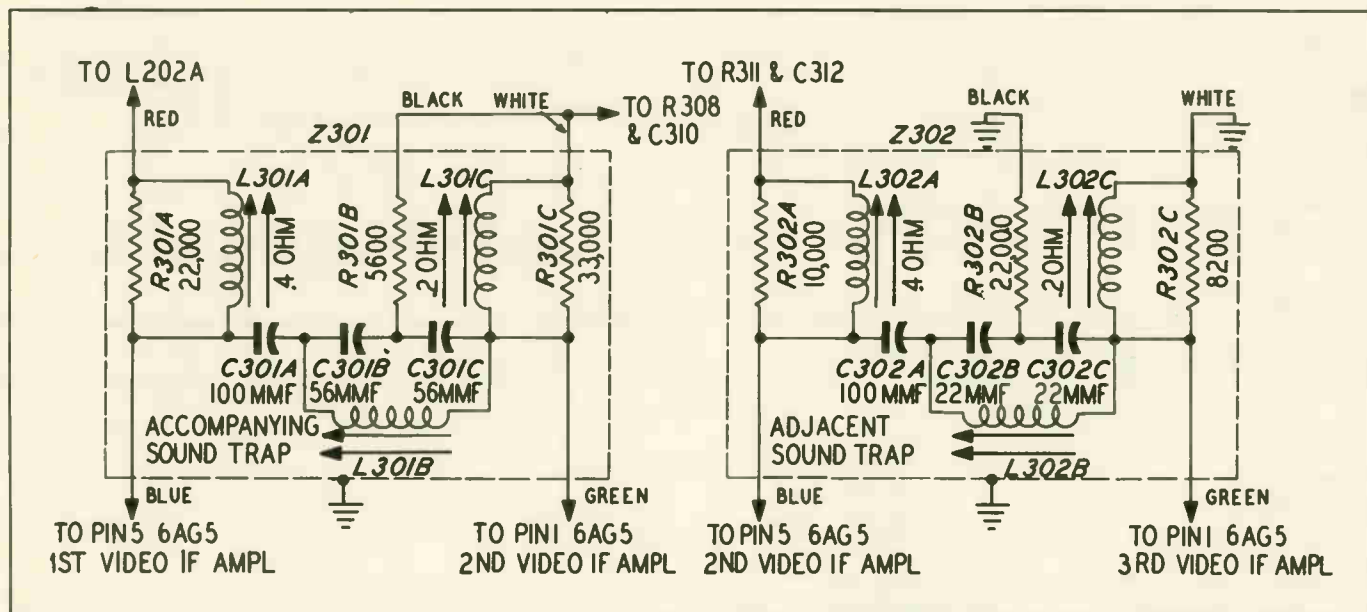
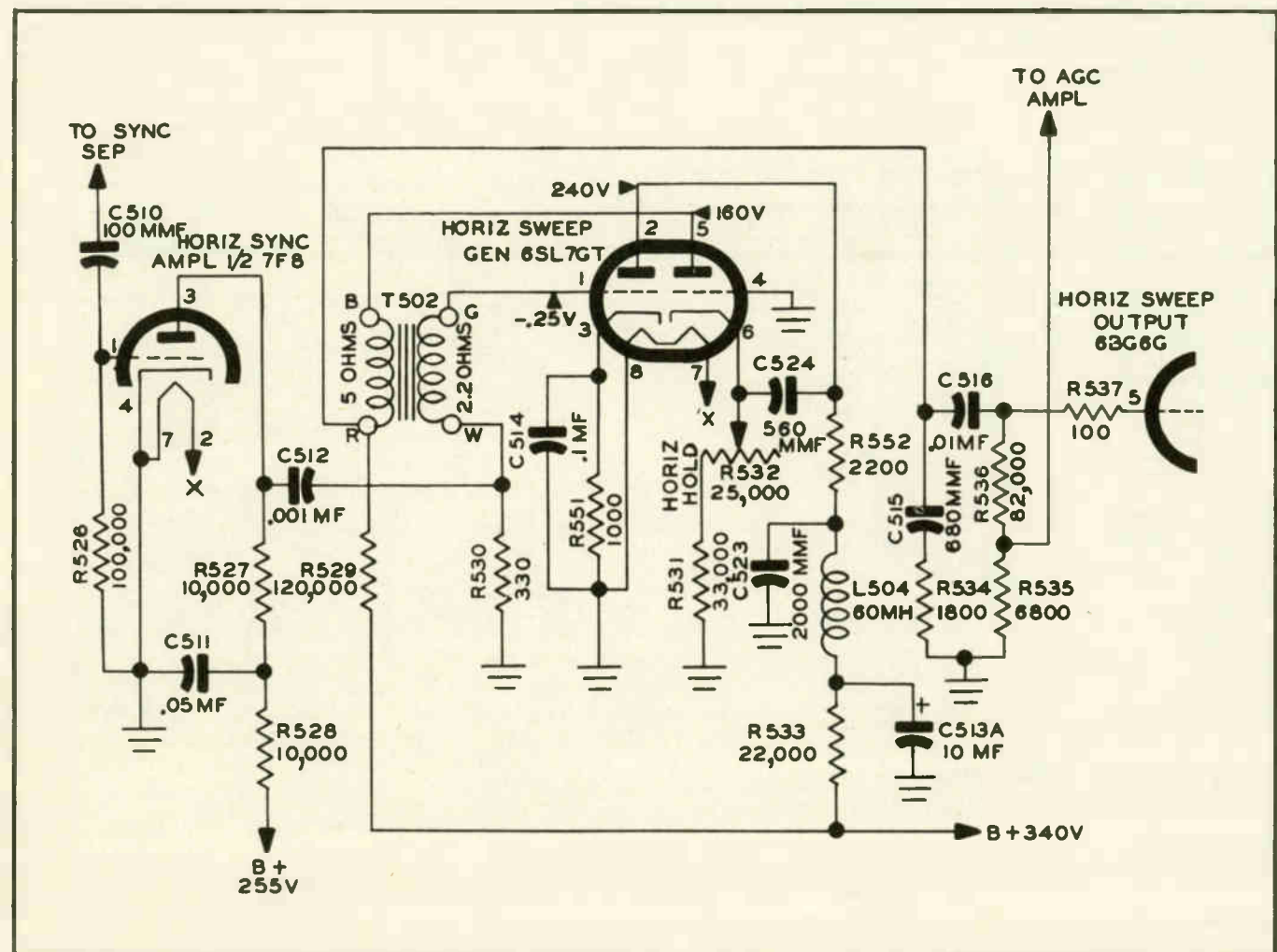

Figure 1. Philco Television Receiver Model 48-1001, Sectionalized Schematic Diagram



TP-5608

Figure 21. Schematic Diagram of First and Second Video I-F Transformers, Z301 and Z302



TP-4085

Figure 22. Changes in Horizontal-Sweep-Generator Circuit, Code 121, Run 3

## SPECIAL CHECKS

### Video-Amplifier-Gain Check

The video amplifier stages should have a gain of 35 to 40. To check the gain, apply a modulated signal from an AM signal generator to the aerial receptacle, J400, and set the frequency to any picture-carrier channel for which coils are provided, or use the test signal from a television station. Connect the calibrated oscilloscope to the video detector output circuit (align test jack J301), and adjust the generator output, or if a station is used, adjust the a-g-c control to obtain a peak-to-peak voltage reading of 2 volts. Now connect the oscilloscope through a .01-mf. condenser to the plate (pin 2) of the video output tube, and note the peak-to-peak voltage: Divide this voltage by the detector voltage (2) to find the gain of the

video stages. This should be about 35 or 40. If the gain is low, try new video-amplifier and video-output tubes; if the gain is still low, check for trouble in these stages.

### D-C Restoration Check

With the CONTRAST control turned fully clockwise, connect a 20,000-ohms-per-volt voltmeter between the picture-tube grid and the chassis. The voltage measured at this point should be approximately 20 to 30 volts positive (with a 2-volt, peak-to-peak signal at the detector).

If the video-amplifier gain is normal, but a lower-than-normal voltage is obtained in the d-c restoration check, trouble is indicated in the d-c-restoration circuit.

## PRODUCTION CHANGES

### CODE 121

#### Run 2

1. A filament choke, L205, Part No. 32-4112-3, was added, in series with pin 4 of the 6AL5 discriminator tube, to reduce harmonic beat. The resistance of the choke is less than 1 ohm.

2. The second and third video-i-f transformers, Z301 and Z302, were redesigned to improve trap stability and aid adjustment.

Z301: Old Part No., 32-4094;  
new Part No., 32-4213

Z302: Old Part No., 32-4094-1;  
new Part No., 32-4213-1

The new transformers are interchangeable with the corresponding originals. Only the new transformers are supplied for replacement purposes. Schematic diagrams of the two transformers are shown in figure 21.

#### Run 3

Changes in the horizontal-sweep-generator circuit (to improve sync stability) were incorporated into this run, together with several other changes, as follows:

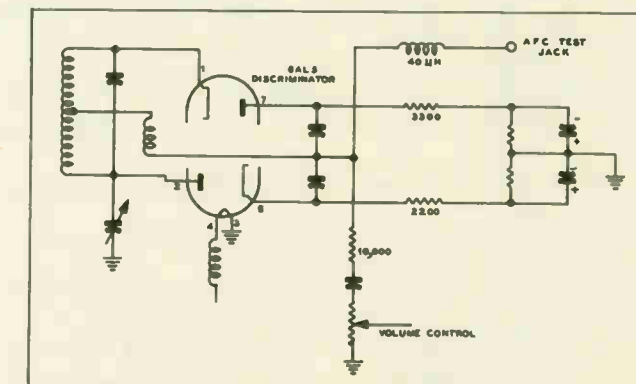

TP9-319

Figure 23. Schematic Diagram of Discriminator Changes

1. R529, 100,000 ohms, Part No. 66-4103340\*, was changed to 120,000 ohms, Part No. 66-4123340\*.

2. R530, 2200 ohms, Part No. 66-2223340\*, was changed to 330 ohms, Part No. 66-1333340\*.

3. R531, 560,000 ohms, Part No. 66-4564340\*, was changed to 33,000 ohms, Part No. 66-3333340\*, and connected as shown in figure 22.



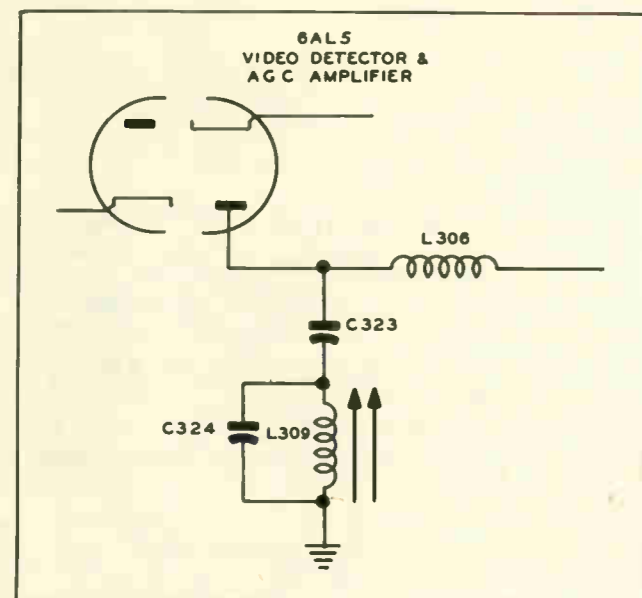

Figure 24. Addition of Accompanying-Sound Trap

4. R532, 250,000 ohms, Part No. 33-5539-13, was changed to 25,000 ohms, Part No. 33-5539-28, and connected as shown in figure 22.
5. R533, 220,000 ohms, Part No. 66-4224340\*, was changed to 22,000 ohms, Part No. 66-3223340\*, and connected as shown in figure 22.
6. R534, 2200 ohms, Part No. 66-2223340\*, was changed to 1800 ohms, Part No. 66-2183340\*.
7. R541, 100,000 ohms, Part No. 66-4103340\*, was changed to 47,000 ohms, Part No. 66-3473340\*.
8. R551, 1000 ohms, Part No. 66-2103340\*, was added, as shown in figure 22.
9. R552, 2200 ohms, Part No. 66-2223340\*, was added, as shown in figure 22.
10. C513A, 10 mf., was connected as shown in figure 22.
11. C514, 820 mmf., Part No. 60-10825401\*, was changed to .1 mf., Part No. 61-0113\*, and connected as shown in figure 22.
12. C515, 820 mmf., Part No. 60-10825401\*, was changed to 680 mmf.,  $\pm 5\%$ , Part No. 60-10685401\*, and connected as shown in figure 22.
13. C516, .01 mf., was connected as shown in figure 22.
14. C523, 200 mmf., Part No. 60-20205304\*, was added, as shown in figure 22.
15. C524, 560 mmf., Part No. 66-10565314\*, was added, as shown in figure 22.
16. L504, 60-mh., r-f choke, Part No. 32-4284, was added, as shown in figure 22.
17. A four-terminal wiring panel, Part No. 12W-45661, was added, between the vertical-sweep-output socket (6V6GT) and C506, on the bottom of the chassis.

18. R338, 390,000 ohms,  $\frac{1}{2}$  watt, Part No. 66-4393340\*, was changed to 1 watt (same value), Part No. 66-4394340\*.

19. R203 and R207, 100,000 ohms,  $\frac{1}{2}$  watt, Part No. 66-4103340\*, were changed to 1 watt (same value), Part No. 66-4104340\*.

20. A 3300-ohm resistor, Part No. 66-2333340\*, was added, and connected between pin 7 of the 6AL5 discriminator tube and the junction of R215 and C217, as shown in figure 23.

21. A 2200-ohm resistor, Part No. 66-2223340\*, was added, and connected between pin 5 of the 6AL5 discriminator tube and the junction of R216 and C218, as shown in figure 23.

22. A 10,000-ohm resistor, Part No. 66-3103340\*, was added, between C215 and the junction of condensers C213 and C214. The tie point (on Code 121 schematic) is located on the condenser (C215) side of the resistor, as shown in figure 23.

23. A choke (a-f-c test jack filter), Part No. 32-4143-1, was added, in series with the a-f-c test jack, as shown in figure 23.

24. An accompanying sound trap, Part No. 32-4218, was added, to reduce the possibility of sound interference appearing in the picture. The ground lead of condenser C323 was disconnected from ground, and connected to the new sound trap (symbolize as L309 and C324). This trap is effectively in series with the detector input, and is tuned to the accompanying-sound frequency, 22.1 mc. The sound-trap condenser C324, 47 mmf., is part of L309. See figure 24.

25. R539, 3900 ohms, Part No. 66-2395340, was changed to 3300 ohms, Part No. 66-2335340.

26. C517, .1 mf., Part No. 61-0113\*, was removed.

27. C518, 47 mmf., Part No. 60-00515307\*, was changed to 270 mmf., Part No. 60-10275407\*.

28. A 1000-mmf. condenser, Part No. 60-20105401\*, was added, between the cathode (pin 3) of the 6BG6G horizontal-sweep-output tube and ground.

29. The high-voltage unit was changed to a complete subassembly, and the shelf material was changed from Part No. 54-7291 to Part No. 54-7291-1, to improve performance at high humidity. This shelf is available as a replacement item.

30. All width controls now used are Part No. 32-4163-1, identified by a black dot.

31. Z202, the discriminator transformer, Part No. 32-4101 (used in Runs 1 and 2), was changed to Part No. 32-4214; the differences are as follows:

- a. C202C, 10 mmf., a fixed loading condenser, part of Z202, replaced C202C, a trimmer in Runs 1 and 2.
- b. C202B, 5 mmf., a balancing condenser, part of Z202, was removed.
- c. C223, 5 mmf., plate by-pass condenser, Part No. 30-1224-5, was connected between the plate (pin 2) of the 7W7 2nd a-i-f amplifier and ground.
- d. L202B, discriminator secondary, slug-tuned,

part of Z202, replaced L202B, fixed. The new transformer is directly replaceable if condenser C223 is added.

## CODE 122 EARLY CHANGES

1. During the early runs of Code 122, the projection tube was modified, bringing the high-voltage-anode snap terminal closer to the front of the tube, to prevent corona or arc-over to the deflection-yoke and picture-tube mounting assembly. When this was done, the anode snap terminal was too close to the keystone-magnet clamp band. The clamp band was modified temporarily by providing a cutout for the anode-terminal clearance and by using a plastic strip at the top of the band. Later, a new all-plastic band was added, to be used with either the old, modified, or new tubes. When replacing tubes, use the new tube, TP400A, and the new magnet clamp band, Part No. 76-3298. When making keystone adjustments on tubes employing the new band, be sure to ground each magnet before touching it, in addition to connecting the ground to the band clamp screw.

The new tube, an aluminum-backed projection type, TP400A, is interchangeable with the old tube, and should be ordered for all replacement purposes.

2. The deflection-yoke assembly was changed slightly. The new assembly, Part No. 32-9613, has resistors R500A and R500B mounted on the outside of the yoke instead of the inside. Because of this change, if a new yoke assembly is used with an early type of optical-housing assembly, it will be necessary to drill a hole in the optical housing, adjacent to the deflection-yoke cable. The hole must be large enough to pass the deflection-yoke cable connector.

3. The channel marker assembly was changed to permit easier removal or replacement of the channel marker tabs. Instead of pasting the tab on a celluloid backing strip, a new bezel was provided, into which the tab can be inserted or removed. The new bezel is Part No. 16616-1, the new tab holder is Part No. 54-4495, and the new tab kit is Part No. 40-6938. The Precision Channel Selector knob was changed to Part No. 76-3185FCP. The old assembly may be replaced with the new assembly.

## CODE 122 LATER CHANGES

### Run 1

Code 122 is similar to Code 121, with the following exceptions.

1. The focus coil and FOCUS and AUX. FOCUS controls were changed from high-resistance to low-resistance type. The circuit is shown in figure 25.

The Sweep Circuits section of the Replacement Parts list is affected as follows:

- R547, 1200-ohm resistor, Part No. 66-2125340, was removed.
- R545, resistor, AUX. FOCUS control, is now 200 ohms, 50 watts, Part No. 33-5547-2.
- R546, FOCUS control, is now 200 ohms, 50 watts, Part No. 33-5547-2.

Z501, focus coil assembly, includes L501.

Code 122 Part No. 76-2631-1 (not interchangeable with Code 121 focus coil).

2. The discriminator transformer Z202, Part No. 32-4101, used in Code 121, was replaced by Part No. 32-4214. Differences are as follows:

C202C, condenser (fixed), loading, 10 mmf., part of Z202, replaced C202C, a trimmer in Code 121.

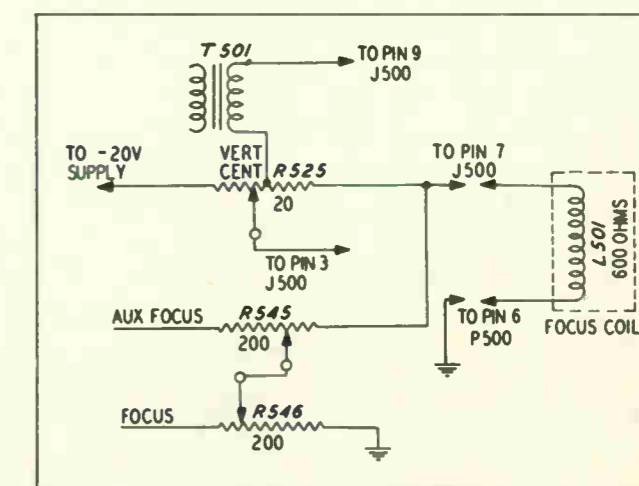

Figure 25. Changes in Focus and Auxiliary Focus Controls, Code 122, Run 1

3. An additional accompanying-sound trap, Part No. 32-4218, was added, to reduce the possibility of sound interference in the picture. The ground lead of condenser C323 was disconnected from ground and connected to the new sound trap (L309 and C324). This trap is effectively in series with the detector input, and is tuned to the accompanying-sound frequency, 22.1 mc.

L309, coil, trap tuning (accompanying sound), Part No. 32-4218.

C324, condenser, sound trap, 47 mmf., part of L309.

4. The lid switch was changed from a mercury type to a toggle switch, Part No. 42-1811. Only the new toggle switch is provided for replacement. Use Part No. 42-1811 when replacing the switch in receivers originally provided with the toggle switch; order the switch, Part No. 42-1811, and the bracket, Part No. 56-4733, when replacing the original Code 121 mercury switch.

### Run 2

Condensers C100, C101, and C102, 1000 mmf., Part No. 30-1229-17, were replaced by 500-mmf. condensers, Part No. 30-1229, with the same voltage rating. The 500-mmf. condensers should be used as replacements.

### Run 3

This run is further identified by the stamping of an "S" on the packing stub, the back of the chassis, and the shipping carton. This run number incorporates extensive changes in the horizontal-sweep circuit, which improved horizontal-sync stability. The changed portion of the horizontal-sweep circuit is shown in figure 22. As compared with the tests at points D, E, and 9 (steps 7, 8, 16, and 18 of Section 5 Trouble Shooting chart), in PR-1444, these circuit changes affect the waveshape appearance.

1. R529, 100,000 ohms, Part No. 66-4103340, was changed to 180,000 ohms, Part No. 66-4183340\*.

2. R530, 2200 ohms, Part No. 66-2223340\*, was changed to 330 ohms, Part No. 66-1333340\*.

3. R531, 560,000 ohms, Part No. 66-4564340\*, was changed to 33,000 ohms, Part No. 66-3333340\*, and connected as shown in figure 22.

4. R532, 250,000 ohms, Part No. 33-5539-13, was changed to 25,000 ohms, Part No. 33-5539-28, and connected as shown in figure 22.

5. R533, 220,000 ohms, Part No. 66-4224340\*, was changed to 22,000 ohms, Part No. 66-3223340\*, and connected as shown in figure 22.

6. R534, 2200 ohms, Part No. 2223340\*, was changed to 1800 ohms, Part No. 66-2183340\*.

7. R551, 1000 ohms, Part No. 66-2103340\*, was added, and connected as shown in figure 22.

8. R552, 2200 ohms, Part No. 66-2223340\*, was added, and connected as shown in figure 22.

9. C513A was connected as shown in figure 22.

10. C514, 820 mmf., Part No. 60-10825401\*, was changed to .1 mf., Part No. 61-0113\*, and connected as shown in figure 22.

11. C515, 820 mmf., Part No. 60-10825401\*, was changed to 680 mmf.,  $\pm 5\%$ , Part No. 60-10685401\*, and connected as shown in figure 22.

12. C516 was connected as shown in figure 22.

13. C523, 2000 mmf., Part No. 60-20205304\*, was added, and connected as shown in figure 22.

14. C524, 560 mmf., Part No. 60-10565314, was added, and connected as shown in figure 22.

15. L504, 60 mh, r-f choke, Part No. 32-4256, was added, and connected as shown in figure 22.

16. A four-terminal wiring panel, Part No. 12W-45661, was added, between the vertical output (6V6GT) socket and C506, on the bottom of the chassis.

17. During Run 3, C107 was removed, and C106 became Part No. 30-2568-19 (special temperature condenser).

### Run 4

The high-voltage circuit was changed. One lead of the 500-mmf. condenser (Part No. 30-1229) which bypasses the filament of the first 1B3GT rectifier tube, was disconnected from ground and connected to terminal 4 of the sweep output transformer.

Some sets prior to Run 4, with a 32-8309-1 transformer and the above circuit change, have the letter "H" stamped on the back of the chassis.

### Run 5

High-voltage transformers Part No. 32-8309-1 and Part No. 32-8345-1 were used in place of Part No. 32-8345 (see Run 4). When Part No. 32-8309-1 transformers are used, the back of the chassis subbase is stamped with the letter "O". Order Part No. 32-8345-1 for replacement.

### Run 6

The following changes were made to improve performance:

1. R505, screen dropping resistor, 1 megohm, Part No. 66-5108340, was changed to a 1-watt resistor (same value), Part No. 66-5104340\*.

2. R506, plate load, 1.2 megohms, Part No. 66-5128340, was changed to a 1-watt resistor (same value), Part No. 66-5124340\*.

### Run 7

The high-voltage unit was changed to a complete subassembly, and the shelf material was changed from Part No. 54-7291 to Part No. 54-7291-1, to improve performance at high humidity. This shelf is available as a replacement item.

### Run 8

The following changes were made, to improve performance:

1. R514, plate load, 470,000 ohms,  $\frac{1}{2}$  watt, Part No. 66-4473340\*, was changed to 1 watt (same value), Part No. 66-4474340\*.

2. R203 and R207, 100,000 ohms,  $\frac{1}{2}$  watt, Part No. 66-4103340\*, were changed to 1 watt (same value); Part No. 66-4104340\*.

3. R529 (see Run 3), 180,000 ohms,  $\frac{1}{2}$  watt, Part No. 66-4183340\*, was changed to 1 watt (same value), Part No. 66-4184340\*.

4. R510, 68,000 ohms,  $\frac{1}{2}$  watt, Part No. 66-3683340\*, was changed to 1 watt (same value), Part No. 66-3684340.

5. R319, 82,000 ohms,  $\frac{1}{2}$  watt, Part No. 66-3823340\*, was changed to 2 watts (same value), Part No. 66-3825340.

6. To reduce harmonic beat interference on Channel 3, a 100-mmf. condenser, Part No. 60-10105407, was added, as a B+ by-pass. This condenser is connected between ground and the junction of L504 (see Run 3), R533, and C513A.

### Run 9

1. To stabilize the a-i-f amplifier, a choke, Part No. 32-4143-1, was added, in series with the a-f-c test jack.

2. To improve performance, R338 was changed to a 1-watt resistor (same value), Part No. 66-4394340\*.

### Run 10

To remove vertical black lines, the following changes were made:

1. R529, 180,000 ohms, Part No. 66-4184250\*, was changed to 120,000 ohms, Part No. 66-4124340\*.

2. R539, 3900 ohms, Part No. 66-2395340, was changed to 3300 ohms, Part No. 66-2335340.

3. C517, Part No. 61-0113\*, was removed.

4. A 1000-mmf. condenser, Part No. 60-20105401\*, was added, between the cathode (pin 3) of the 6BG6G horizontal-sweep-output tube and ground.

5. C518, 47 mmf., Part No. 60-00515307\*, was changed to 270 mmf., Part No. 60-10275407\*.

### NOTE

Runs 6, 7, and 8 (Code 122) were changed slightly, to improve the AM-FM ratio. All chassis so modified are identified by a diamond stamp mark at the rear of the chassis, near the C.R.T. socket. This modification involves the following changes:

1. A 3300-ohm resistor, Part No. 66-2333340\*, was added, and connected between pin 7 of the 6AL5 discriminator tube and the junction of R215 and C217.

2. A 2200-ohm resistor, Part No. 66-2223340\*, was added, connected between pin 5 of the 6AL5 discriminator tube and the junction of R216 and C218.

3. A 10,000-ohm resistor, Part No. 66-3103340\*, was added, between C215 and the junction of condensers C213 and C214. The tie point is located on the condenser (C215) side of the resistor.

The above modifications also apply to Model 48-2500-5, Code 122, Runs 2 and 3.

### MODEL 48-2500-5 (50 CYCLES), CODE 122

### Run 1

This set is similar to Model 48-2500, Code 122, Run 3, with these exceptions:

An additional 30-mf. condenser, Part No. 30-2568-19, is added, in parallel with C106. The power transformer is physically repositioned.

### Run 2

1. The high-voltage unit was changed to a complete subassembly, and the shelf material was changed from Part No. 54-7291 to Part No. 54-7291-1, to improve performance at high humidity. This shelf is available as a replacement item.

2. R514, plate load, 470,000 ohms,  $\frac{1}{2}$  watt, Part No. 66-4473340\*, was changed to 1 watt (same value), Part No. 66-4474340\*.

3. R203 and R207, 100,000 ohms,  $\frac{1}{2}$  watt, Part No. 66-4103340\*, were changed to 1 watt (same value), Part No. 66-4104340\*.

4. R529, 180,000 ohms,  $\frac{1}{2}$  watt, Part No. 66-4183340\*, was changed to 1 watt (same value), Part No. 66-4184340.

5. R510, 68,000 ohms,  $\frac{1}{2}$  watt, Part No. 66-3683340\*, was changed to 1 watt (same value), Part No. 66-3684340.

6. R319, 82,000 ohms,  $\frac{1}{2}$  watt, Part No. 66-3823340\*, was changed to 2 watts (same value), Part No. 66-3825340.

(All changes of  $\frac{1}{2}$ -watt to 1-watt resistors are made to improve performance.)

### Run 3

1. To reduce harmonic beat interference on Channel 3, a 100-mmf. condenser, Part No. 60-10105407, was added, as a B+ by-pass. This conference is connected between ground and the junction of L504, R533, and C513A.

2. To stabilize the a-i-f amplifier, a choke, Part No. 32-4143-1, was added, in series with the a-f-c test jack.

3. To improve performance, R338 was changed to a 1-watt resistor, Part No. 66-4394340\*.

4. To remove vertical black lines, the following changes were made:

a. R529, 180,000 ohms, Part No. 66-4184250\*, was changed to 120,000 ohms, Part No. 66-4124340\*.

b. R539, 3900 ohms, Part No. 66-2395340, was changed to 3300 ohms, Part No. 66-2335340\*.

c. C517, Part No. 61-0113\*, was removed.

d. A 1000-mmf. condenser, Part No. 60-20105401\*, was added, between the cathode (pin 3) of the 6BG6G horizontal-sweep-output tube and ground.

e. C518, 47 mmf., Part No. 60-00515307\*, was changed to 270 mmf., Part No. 60-10275407\*.

C202B, condenser, balancing, 5 mmf., part of Z202, was removed.

C223, condenser, plate by-pass, 5 mmf., Part No. 30-1224-5, was connected between the plate (pin 2) of the 7W7 2nd a-i-f amplifier tube and ground.

L202B, discriminator secondary, slug-tuned, part of Z202, replaced L202B, fixed, in Code 121.

The new transformer is directly replaceable in Code 121 if condenser C223 is added.



Group 1

- Models 49-1002, Code 121  
 49-1040, Code 121  
 49-1075, Codes 121 and 122  
 49-1076, Code 122  
 49-1240, Codes 121 and 123  
 49-1275, Code 121  
 49-1278, Code 122  
 49-1280, Code 122

CIRCUIT VARIATIONS

Model 49-1075, Code 121—used as the basic model for group 1A. It is a television-radio-phonograph combination, and employs a 10-inch picture tube.

Model 49-1075, Code 122—same chassis as Model 49-1075, Code 121; however, an M-9 record changer is used in this model.

Model 49-1076, Code 122—identical to Model 49-1075, Code 122, run 5.

Model 49-1240, Code 121—a console model electrically similar to Model 49-1075, Code 121, with minor circuit differences.

Model 49-1240, Code 123—the same electrically and mechanically as Model 49-1240, Code 121, except that a different type of a-c interlock was used.

Model 49-1275, Code 121—similar to Model 49-1075, Code 121, except that it uses an M-9 record changer. It has a 12-inch picture tube and a voltage-doubling high-voltage supply and other minor circuit differences.

Model 49-1278, Code 122—identical to Model 49-1275, Code 121, run 6.

Model 49-1280, Code 122—chassis identical to Model 49-1275, Code 121, run 6; however, the cabinets of these two models are different.

Group 1A

- Models 49-1075, Codes 121 and 122  
 49-1076, Code 122  
 49-1240, Codes 121 and 123  
 49-1275, Code 121  
 49-1278, Code 122  
 49-1280, Code 122

All models in Group 1 except Model 49-1002, Code 121, and Model 49-1040, Code 121, use the schematic diagram of Model 49-1075, Code 121, as the basic circuit. This schematic diagram is also applicable to Model 49-1075, Code 122, and, with production changes, to Model 49-1076, Code 122. The television circuits for Models 49-1240, Code 121, 49-1240, Code 123, 49-1275, Code 121, 49-1278, Code 122, and 49-1280, Code 122, are similar to those for Model 49-1075. Variations in the circuits of these models are shown in figures 61 through 67. In addition, R106 and I100, shown in the schematic diagram for Model 49-1075, are not used in Model 49-1240, Code 121, and Model 49-1240, Code 122.

PRODUCTION CHANGES

Production changes are classified by run numbers. Not only does the "main chassis" have its own run number, but certain "subchassis" carry separate run numbers. These run numbers may, or may not, coincide with one another; therefore, where production changes apply only to a certain subchassis, the information is given for a definite run of the unit.

The run numbers of subchassis are stamped on the units in simple numbers which directly indicate the run.

MODEL 49-1075, CODE 121 (MAIN CHASSIS)

RUN NO.	DESCRIPTION OF CHANGE	NEW OR ADDED PART NO.	OLD OR REMOVED PART NO.	REASON FOR CHANGE
2	R329, 4700-ohm resistor, changed to 15,000 ohms. The following wiring changes were made (refer to schematic): a. Lead connecting R513 to junction of R101 and C110 removed. b. Orange lead from pin 10 of 10BP4 picture tube removed from junction of C320, C323, R328, and R329, and connected to junction of C502A, R507, and R508. c. Connecting lead added from R513 (bottom) to junction of C502A, R507, and R508. d. Condenser C510, .1 mf., disconnected from transformer side of R525 and connected to same side as VERT. HOLD control.	66-3154340	66-2474340	To reduce interaction between circuits.
2	The power transformer part number changed.	32-8376	32-8357	To facilitate material procurement.

MODEL 49-1075, CODE 121 (MAIN CHASSIS)

RUN NO.	DESCRIPTION OF CHANGE	NEW OR ADDED PART NO.	OLD OR REMOVED PART NO.	REASON FOR CHANGE
3	A 10-mf. condenser added between top of R330 and ground. Physical wiring is as follows: The common tie point (lug) on the terminal strip for R327 and R328 was moved to the next lug at the left. The wire connecting these two lugs was removed. The 10-mf. condenser was then added, between the first lug (from which R327 and R328 were removed) and ground; the ground connection was made at the lug located on the terminal strip immediately beside the 7Z4 rectifier tube. A lead was then connected between the condenser and the top of R330.	30-2417-6		To provide tuner B+ decoupling.

MODEL 49-1075, CODE 122 (MAIN CHASSIS)

RUN NO.	DESCRIPTION OF CHANGE	NEW OR ADDED PART NO.	OLD OR REMOVED PART NO.	REASON FOR CHANGE
2	R329 changed from 4700 ohms to 15,000 ohms.	66-3154340	66-2474340	To reduce interaction between circuits.
2	Power transformer changed.	32-8376	32-8457	To facilitate material procurement.
3	10-mf. condenser added between top of R330 and ground.	30-2417-6		To reduce hum modulation.
4	R543, 10,000-ohm resistor, added in series with movable arm of R502.	66-3103340		To prevent overloading of HEIGHT control.
5	R532 changed from 33,000 ohms to 36,000 ohms (obtained by placing a 56,000-ohm resistor and a 100,000-ohm resistor in parallel).	66-3563340 66-4103340	66-3334340	To improve horizontal control range.

MODEL 49-1076, CODE 122 (MAIN CHASSIS)

RUN NO.	DESCRIPTION OF CHANGE	NEW OR ADDED PART NO.	OLD OR REMOVED PART NO.	REASON FOR CHANGE
6	56-ohm resistor added in cathode circuit of 7Z4.	66-0565340		To reduce surge currents.
6	During run 6, 1800-ohm resistor added in series with C513 and ground.	66-2183340		To improve picture centering.
7	R532 changed to 39,000 ohms.	66-3398340	66-3363340 66-4103340	To improve picture centering.
8	1800-ohm resistor in series with C513 and ground removed. Loose end of C513 grounded.		66-2183340	To increase picture width.

NOTE: Model 49-1076, Code 122, is identical to Model 49-1075, Code 122, run 5, and the run numbers were continued from that point; that is, the first production of Model 49-1076, Code 122 was numbered run 5 so that the first change in circuit design was numbered run 6.

MODEL 49-1240, CODES 121 AND 123 (MAIN CHASSIS)

RUN NO.	DESCRIPTION OF CHANGE	NEW OR ADDED PART NO.	OLD OR REMOVED PART NO.	REASON FOR CHANGE
2	Power transformer changed.	32-8376	32-8357	To facilitate material procurement.
2	10-mf. condenser added between top of resistor R330 and ground. The physical wiring is as follows: The common tie point (lug) on the terminal strip for R327 and R328 was moved to the next lug at the left. The wire connecting these two lugs was removed. The 10-mf. condenser was then added, between the first lug (from which R327 and R328 were removed) and ground; the ground connection was made at the lug located on the terminal strip immediately beside the 7Z4 rectifier tube. A lead was then connected between the condenser and the top of R330.	30-2417-6		To provide tuner B+ decoupling.

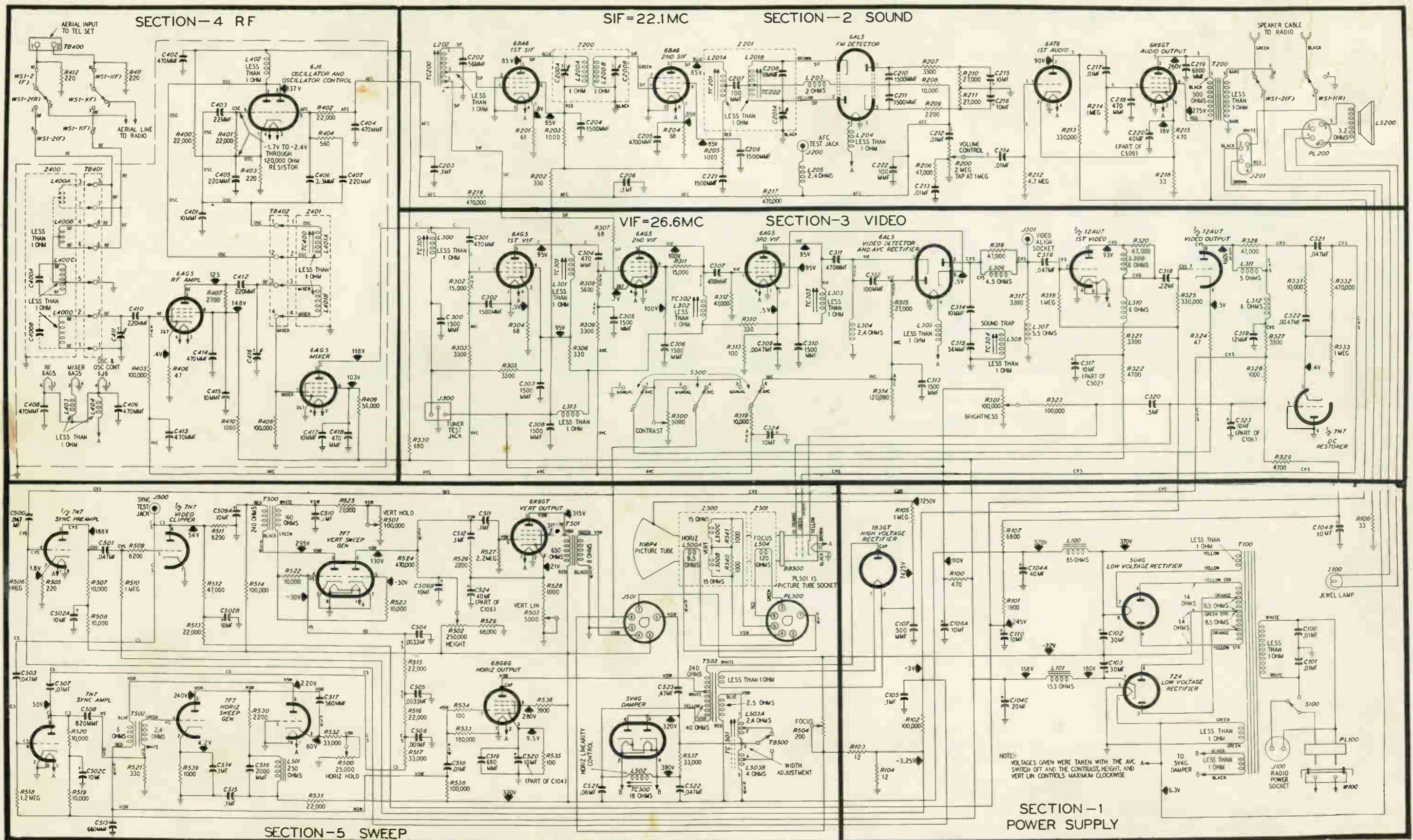

Figure 68. Complete Sectionalized Schematic Diagram, Group 1A Models, Showing Test Voltages

# TELEVISION GROUP 1B

## CIRCUIT VARIATIONS

Model 49-1002, Code 121—used as the basic model for Group 1B. It is a table model television set with a 10-inch picture tube.

Model 49-1040, Code 121—the same as Model 49-1002, Code 121, run 4, except for minor circuit differences.

## PRODUCTION CHANGES

### MODEL 49-1002

RUN NO.	DESCRIPTION OF CHANGE	NEW OR ADDED PART NO.	OLD OR REMOVED PART NO.	REASON FOR CHANGE
2	R538 changed to 150,000 ohms.	66-4153340	66-4103340	To increase width of picture.
3	R544, 1800-ohm resistor, added in series with C513 and ground.	66-2183340		To modify width to center range of WIDTH control.
4	R532 changed to 36,000 ohms (obtained by placing a 56,000-ohm resistor and a 100,000-ohm resistor in parallel).	66-3563340 66-4103340	66-334340	To improve horizontal-hold control range.
4	10,000-ohm resistor placed in series with arm of HEIGHT control, R502.	66-3104340		To prevent overloading of HEIGHT control.

### MODEL 49-1040, CODE 121

2	R532 changed to 39,000 ohms.	66-3398340	66-3363340 66-4103340	To improve horizontal hold-control range.
3	R544 removed and C513 grounded.		66-2183340	To increase width of picture.

### Group 1B

Models 49-1002, Code 121  
49-1040, Code 121

## SERVICE HINTS

Model 49-1002, Code 121  
Model 49-1040, Code 121  
Model 49-1075, Codes 121 and 122  
Model 49-1076, Code 122  
Model 49-1240, Codes 121 and 123  
Model 49-1275, Code 121  
Model 49-1278, Code 122

### IMPROVING SYNCHRONIZATION

When Group 1 models are operated with the CONTRAST control set near its maximum clockwise position, the synchronization may be affected, because of the fact that some of the video signal is passed into the sync amplifiers.

To reduce this effect, the sync take-off point may be moved from the video-output stage to the video detec-

tor. A 10,000-ohm isolating resistor should be added to prevent loading of the video-detector output network.

It is suggested that the above changes be made as follows:

1. Mount a single-lug terminal strip near the video-output tube socket.
2. Add a 10,000-ohm resistor, Philco Part No. 66-3108340, between J301 and the insulated terminal of the above strip.
3. Remove C500 and the wire that connects it to pin 4 of the 7N7 sync-preamplifier tube. Rewire C500 to pin 4 and the 10,000-ohm resistor added in step 2.
4. Dress the picture-tube grid lead as far away as possible from C500 and the 10,000-ohm resistor.
5. Return the grid of the sync separator to ground

by rewiring the cold end of R510 to the adjacent terminal.

### PICTURES EXHIBITING FINE BEAT PATTERN

When the AVC OFF-ON switch is ON, Group 1 models may exhibit a fine beat pattern for a certain setting of the CONTRAST control. This condition may be caused by video feedback from the video-amplifier stages, and may be reduced by dressing the following condensers as close to the chassis as possible.

1. Blocking condenser between the video detector and the first video amplifier.
2. Blocking condenser between the first-video-amplifier plate and the second-video-amplifier grid.
3. Blocking condenser between the second-video-amplifier plate and the picture-tube grid.

The lead feeding the picture-tube grid should be dressed away from the chassis by a fish-paper standoff.

In some cases it may also be necessary to shield the wire connecting the CONTRAST control to the AVC ON-OFF switch. This may be done as follows:

1. Remove the ground connection to the CONTRAST control.
2. Rewire the ground connection of the BRIGHTNESS control directly to the ground terminal of the terminal panel next to the VOLUME control.
3. Replace the wire connecting the CONTRAST control and the AVC ON-OFF switch with an insulated shielded wire. Dress the shielded wire exactly as the original wire.
4. Connect the braid of the shielded wire to the original ground terminal of the CONTRAST control, and the center conductor to the center terminal of the control.
5. Ground the braid of the shielded wire to the ground terminal to which C100 is grounded.
6. Connect the center conductor of the shielded wire to the appropriate terminal on the AVC ON-OFF switch.

### PICTURES EXHIBITING TRAILING WHITES OR BLACKS

Group 1 models may also exhibit trailing whites or blacks when reproducing certain types of pictures. This condition may be reduced by rewiring the video-output circuit, making it similar to the one used in Model 49-1040, Code 123.

The modification consists of removing the 12-mmf. high-frequency compensating condenser, C319, and adding a 10,000-ohm resistor in parallel with the two plate-load resistors, R327 and R328.

### REDUCTION OF OSCILLATOR DRIFT

The a-f-c system used in Philco receivers is designed to compensate for local-oscillator drift automatically.

In some receivers the combination of local-oscillator drift and discriminator drift may be in such a direc-

tion and of such a magnitude that the a-f-c system cannot compensate for the change. This is usually evidenced as a need for periodic readjustment of the oscillator coils.

The excessive discriminator drift can be substantially reduced by the use of the new discriminator transformer, Part No. 32-4317, and the excessive oscillator drift can be substantially reduced by replacing the oscillator grid-tank trimmer condenser with a special temperature-coefficient condenser.

The above changes are suggested whenever the excessive-drift problem is encountered and whenever discriminator transformer 32-4214-4 (used in all models except 49-1002 and 49-1040, Code 121) requires replacing. The procedures for making the changes are as follows:

1. Replace the discriminator balancing choke with a 47-ohm resistor, Philco Part No. 66-0478340.
2. Remove the 5-mmf. condenser connected from the plate of the 2nd sound-i-f tube (pin 2) to ground.
3. Remove the original discriminator transformer, noting the connections and lead dress.
4. For alignment purposes, identify and mark the secondary tuning adjustment of the new transformer by observing which tuning core tunes the secondary coil (the winding to which the yellow and brown leads are connected).
5. Install, connect, and dress the leads of the new transformer the same as for the original transformer.
6. The sound-i-f system is realigned as instructed in the alignment procedure for receivers having three video-i-f stages, in Section I of this year-book.

When the discriminator transformer requires replacing, kit Part No. 45-9593 should be ordered. This kit includes a 32-4317 discriminator transformer, a 47-ohm resistor, and installation instructions.

### REPLACEMENT OF HINGES

In the early-production runs of Models 49-1075 and 49-1275, the hinges of the TV door were of different design from those that were used in the later-production runs. The part numbers in the manual refer to the latter-type hinges. The part numbers of the TV door hinges used in early production are as follows:

Right-hand, knife stop, mahogany—56-4882

Right-hand, knife, mahogany—56-5522

The difference between the two types of hinges is in the weight of the material and in the over-all length when they are folded. The earlier type hinge is lighter and shorter than the improved type. The over-all length of the improved hinge when folded is  $2\frac{3}{4}$  inches.

If the earlier type hinges fail, it is suggested that they be replaced with the latter type. Because the latter type hinges are longer, it is necessary to rout out the door when making the replacement.

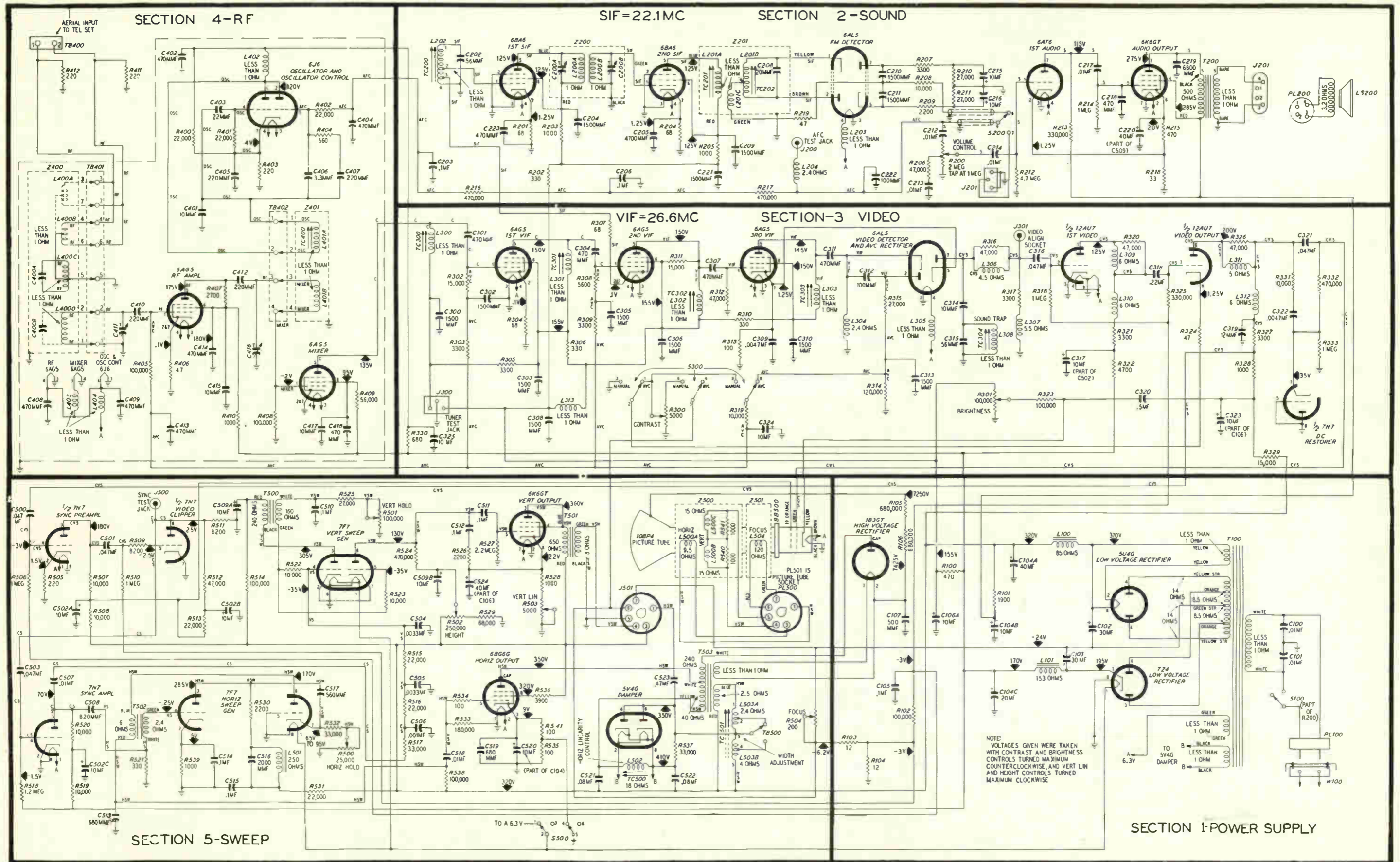

Figure 70. Complete Sectionalized Schematic Diagram, Group 1B Models Showing Test Voltages

TP-6994-1







**MODEL 49-1240, CODES 121 AND 123 (MAIN CHASSIS) (Cont.)**

RUN NO.	DESCRIPTION OF CHANGE	NEW OR ADDED PART NO.	OLD OR REMOVED PART NO.	REASON FOR CHANGE
3	R330 changed from 680 ohms to 10,000 ohms, 10 watts, and wired to 320-volt supply instead of 158-volt supply.	33-1335-47	66-1684340	To reduce drain on 7Z4.
4	C522 changed from .047 mf. to .08 mf.	30-4651-3	61-0122	To improve horizontal linearity.
5	R107, 56-ohm resistor, added in cathode circuit of 7Z4.	66-0565340		To reduce surge currents.

**MODEL 49-1275, CODE 121 (MAIN CHASSIS)**

3	R330 changed from 680 ohms to 10,000 ohms, 10 watts, and wired to 320-volt supply instead of 158-volt supply.	33-1335-47	66-1684340	To reduce drain on 7Z4.
4	C522 changed from .047 mf. to .08 mf.	30-4651-3	61-0122	To improve horizontal linearity.
5	R532 changed from 33,000 ohms to 36,000 ohms (obtained by placing a 56,000-ohm resistor and a 100,000-ohm resistor in parallel).	66-0565340 66-4103340		To improve horizontal control range.
6	R107, 56-ohm resistor, added in cathode circuit of 7Z4.	66-0565340		To reduce surge currents.
6	During run 6, 1800-ohm resistor added in series with C513 and ground.	66-2183340		To modify width, to center range of WIDTH control.

NOTE: Runs 1 and 2 of the Model 49-1275, Code 121, "main chassis" are identical; the difference in identification is due to an error in marking.

**MODEL 49-1278, CODE 122; AND MODEL 49-1280, CODE 122 (MAIN CHASSIS)**

7	R532 changed to 39,000 ohms.	66-3398340	66-3363340 66-4103340	To modify width, to center range of WIDTH control.
8	1800-ohm resistor in series with C513 and ground removed. Loose end of C513 grounded.		66-2183340	To increase picture width.

NOTE: Model 49-1278, Code 122, and Model 49-1280, Code 122, are identical to Model 49-1275, Code 121, run 6, and the run numbers were continued from that point; that is, the first production of these models was numbered run 6 so that the first change in circuit design was numbered run 7.

**ALL MODELS (I-F SUBCHASSIS)**

2	470-mmf. condenser added across cathode resistor (R201) of 1st sound-i-f tube.	62-147001001		To increase sound-i-f sensitivity.
3	L300, L301, L302 changed.	32-4359	32-4234-1	To facilitate padding.
4	Z201 changed to improve transformer.	32-4317	32-4236	To increase noise rejection and reduce drift.

To determine the run number of a main chassis, examine the series of numbers stamped in ink on the rear of the chassis. The last two digits of the series give the run number.

The run number of a subchassis is stamped on the unit as a simple number which directly indicates the run.

**MODELS 49-1150, CODE 122, 49-1150, CODE 124, 49-1240, CODE 124, 49-1278, CODE 123, 49-1279, CODE 122, AND 49-1280, CODE 121 (MAIN CHASSIS)**

RUN NO.	DESCRIPTION OF CHANGE	NEW OR ADDED PART NO.	OLD OR REMOVED PART NO.	REASON FOR CHANGE
2	C511 changed from .0047 mf. to .0056 mf.	45-3500-7	45-3502	To improve vertical sync.
3	.001-mf. condenser added in parallel with C419.	45-3500-5		To reduce video modulation in local oscillator.
4	150-mmf. condenser added between pin 8 of vertical-blocking-oscillator tube and ground.	60-10155407		To reduce hum radiation.
5	R538 changed from 10,000 ohms to 68,000 ohms.	66-3688340	66-3108340	To improve vertical linearity.
5	C525 changed from .05 mf. to .082 mf.	30-4651-3	61-0122	To improve vertical linearity.
5	3300-ohm resistor added in the lead between C525 and the junction of C527 and R545.	66-2338340		To improve vertical linearity.
5	R502 disconnected from 320-volt supply and reconnected to pin 8 of the damper tube.			To improve vertical linearity.

**MODEL 49-1040, CODE 123 (MAIN CHASSIS)**

2	R548, 10,000-ohm resistor, added in the lead between pin 4 of the sync amplifier and the junction of C504, C505, and R512.	66-3108340		To remove video from sync.
3	C511 changed from .0047 mf. to .0056 mf.	45-3500-7	45-3502	To improve vertical sync.
3	.001-mf. condenser added in parallel with C419.	45-3500-5		To reduce video modulation in local oscillator.
4	150-mmf. condenser added between pin 6 of the vertical-blocking-oscillator tube and ground.	60-10155407		To reduce hum radiation.
5	Fuse F100 and fuse holder physically moved from under the chassis to the bracket that holds the width-adjustment link in the high-voltage cage, and electrically moved to the opposite lead of L100.			To provide additional safety measures.
5	The ungrounded end of R109 moved to the junction of L100 and F100.			To provide additional safety measures.
6	R538 changed from 10,000 ohms to 68,000 ohms.	66-3688340	66-3108340	To improve vertical linearity.
6	C525 changed from .05 mf. to .082 mf.	30-4651-3	61-0122	To improve vertical linearity.
6	3300-ohm resistor added in the lead between C525 and the junction of C527 and R545.	66-2338340		To improve vertical linearity.
6	R502 disconnected from 320-volt supply and reconnected to pin 8 of damper tube.			To improve vertical linearity.

**MODELS 49-1076, CODE 123, AND MODEL 49-1077, CODE 122 (MAIN CHASSIS)**

2	C511 changed from .0047 mf. to .0056 mf.	45-3500-7	45-3502	To improve vertical sync.
2	150-mmf. condenser added between pin 8 of the vertical-blocking-oscillator tube and ground.	60-10155407		To reduce hum radiation.

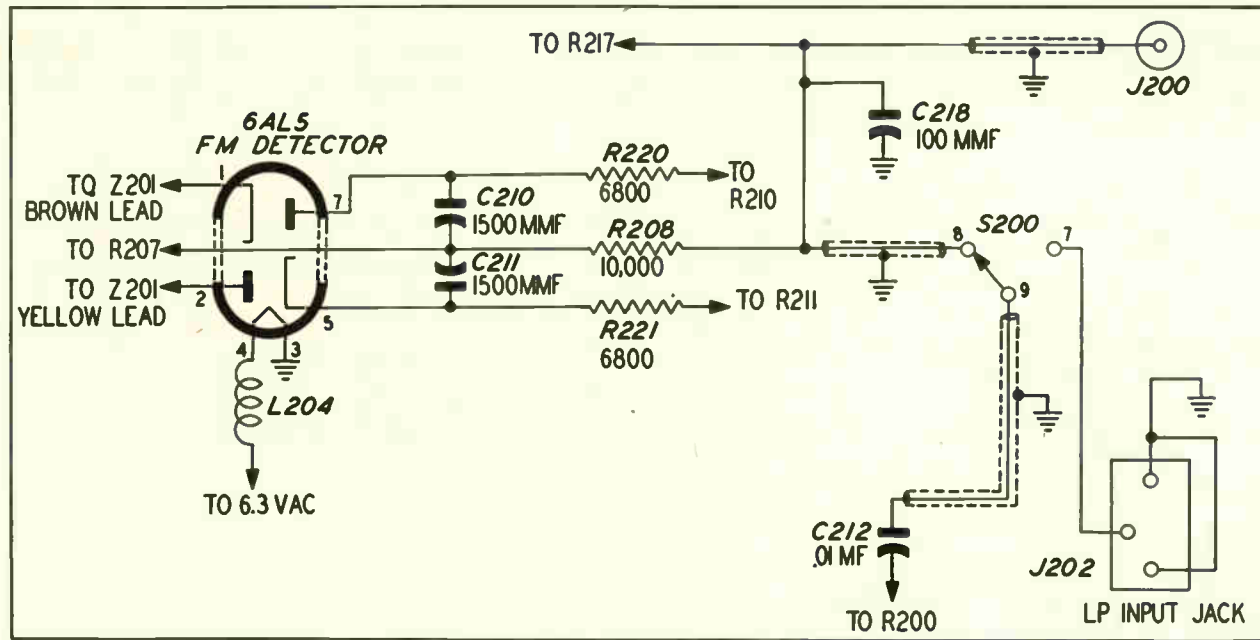

TP-7859

Figure 93. FM-Detector Output Circuit of Model 49-1040, Code 123, Model 49-1150, Codes 122 and 124, and Model 49-1240, Code 124

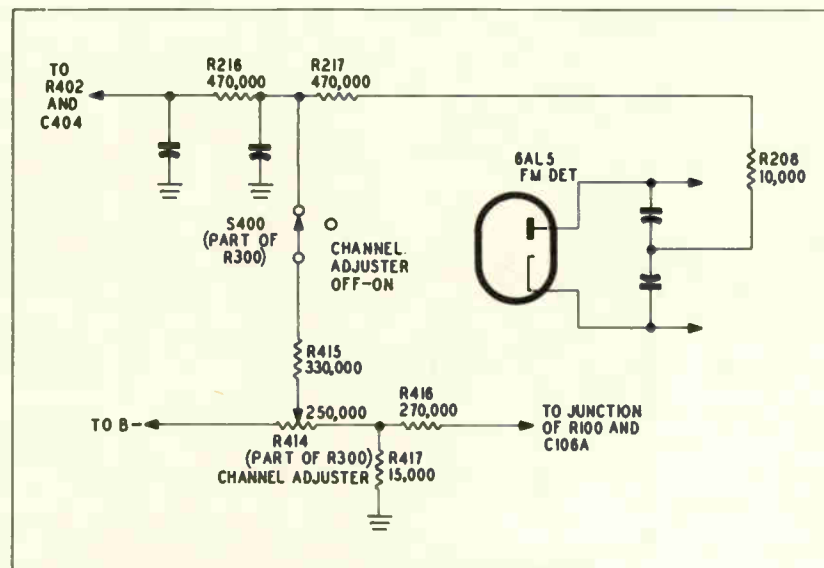

TP-9119

Figure 94. Philco CHANNEL ADJUSTER Circuit, Model 49-1150, Code 124, and Model 49-1175, Code 124

### PRODUCTION CHANGES

Production changes are classified by run numbers. Each main television chassis and radio chassis has its own run number, and certain subchassis carry separate run numbers. The run numbers on the main chassis

and subchassis may or may not coincide with each other. Where production changes apply only to a certain subchassis, the information is given for a definite run number of that unit.

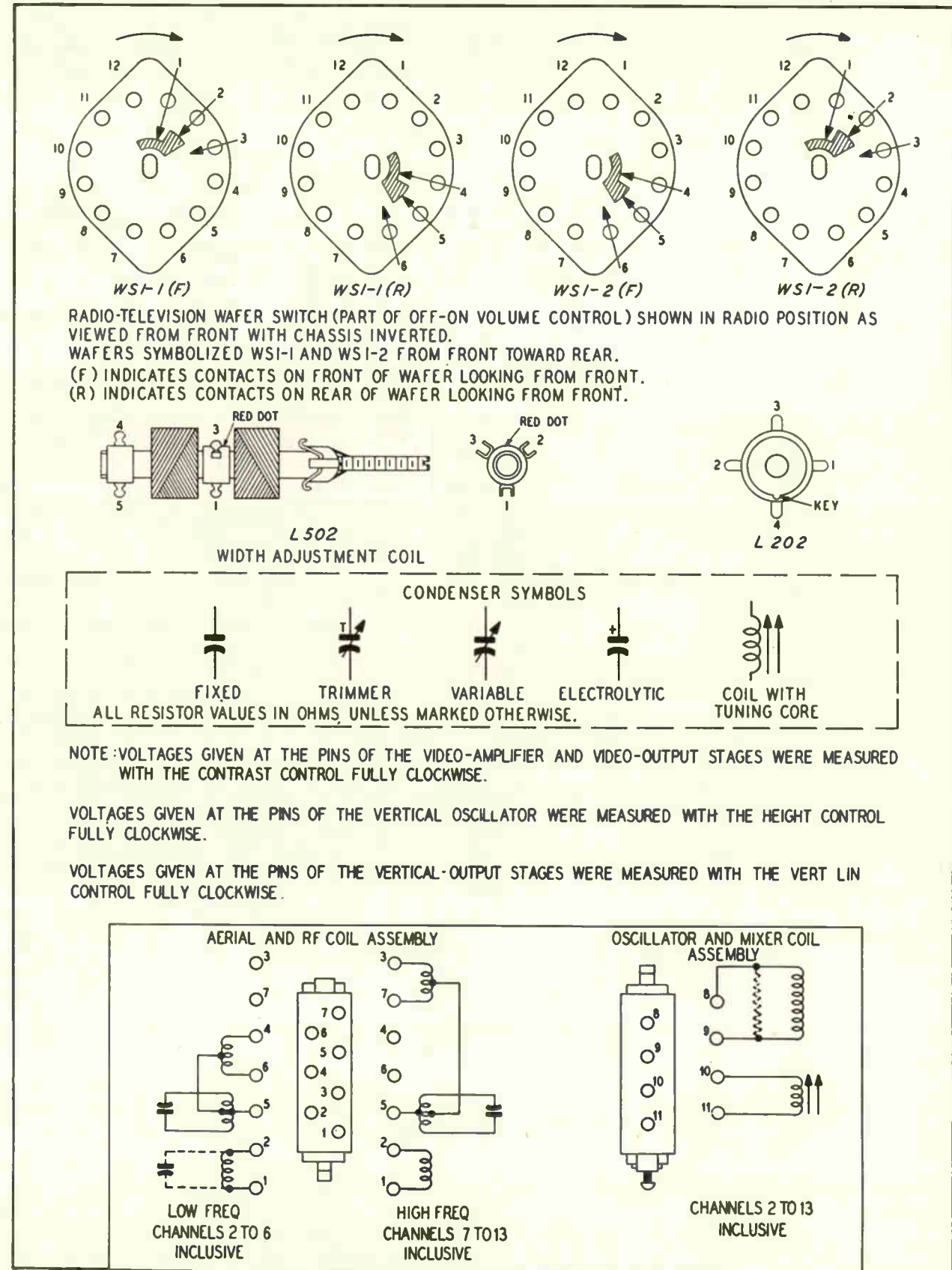

Figure 85. Wafer Switches, Notes, Tuners, Etc.,

**MODELS 49-1076, CODE 123, AND MODEL 49-1077, CODE 122 (MAIN CHASSIS) (Cont.)**

RUN NO.	DESCRIPTION OF CHANGE	NEW OR ADDED PART NO.	OLD OR REMOVED PART NO.	REASON FOR CHANGE
2	Fuse F100 and fuse holder physically moved from under the chassis to the bracket that holds the width-adjustment link in the high-voltage cage, and electrically moved to the opposite lead of L100. The ungrounded end of R109 moved to the junction of L100 and F100.			To provide additional safety measures.
3	.001-mf. condenser added in parallel with C419.	45-3500-5		To reduce video modulation in local oscillator.
3	R538 changed from 10,000 ohms to 68,000 ohms.	66-3688340	66-3108340	To improve vertical linearity.
3	C525 changed from .05 mf. to .082 mf.	30-4851-3	61-0122	To improve vertical linearity.
3	3300-ohm resistor added in the lead between C525 and the junction of C527 and R545.	66-2338340		To improve vertical linearity.
3	R502 disconnected from 320-volt supply and re-connected to pin 8 of damper tube.			To improve vertical linearity.

**GROUP 2 MODELS (TUNER UNIT)**

2	Choke added in the B+ lead to the local oscillator, between the ungrounded end of C419 and the junction of L402 and C402	32-4112-11		To reduce video modulation in local oscillator.
3	C401 changed to a special temperature-coefficient condenser.	30-1224-51	30-1224-39 or 62-010009001	To reduce local-oscillator drift.

**GROUP 2 MODELS (I-F SUBCHASSIS)**

2	R220, 6800-ohm resistor, added in the lead between the ungrounded end of R210 and the junction of C210 and pin 7 of the FM-detector tube.	66-2688340		To reduce harmonic beat.
2	R221, 6800-ohm resistor, added in the lead between the ungrounded end of R211 and the junction of C211 and pin 5 of the FM-detector tube.	66-2688340		To reduce harmonic beat.
3	L300 changed to an improved coil.	32-4359-4	32-4359-2	To increase video-i-f gain.
4	4.7-ohm resistor added in the lead between pin 3 of the FM-detector tube and ground.	66-9478340		To reduce hum.
5	C222, 470-mmf. condenser, added between pin 7 of the first sound-i-f tube and ground.	62-147001001		To increase sound-i-f gain.
6	10-mmf. condenser added in parallel with C303.	62-010009001		To prevent oscillation of video-i-f stage.
6	10-mmf. condenser added in parallel with C308.	62-010009001		To prevent oscillation of video-i-f stage.

**SERVICE HINTS**

**CHANGES IN RATING OF B+ PROTECTIVE FUSE**

Model 49-1040, Code 123  
 Model 49-1240, Code 124  
 Model 49-1278, Code 123  
 Model 49-1280, Code 121

The value of the protective fuse in the first productions of the above models was 1/4 ampere. It was found that under normal operating conditions the current surge encountered during the warm-up period may cause the fuse to melt. Therefore, its value was changed to 1/2 ampere. The chassis using the 1/2-ampere fuse has "1/2" stamped on the rear.

After extensive tests, it was found that a 3/8-ampere fuse withstands the normal current surge and also provides greater protection than the 1/2-ampere fuse. The 3/8-ampere fuse is used in all later productions of these models.

Whenever fuse replacements are made in the field, a 3/8-ampere fuse should be used, regardless of the value originally in the receiver. The part number of the 3/8-ampere fuse is 45-2656-10.

**INACCESSIBILITY OF HIGH-FREQUENCY-AERIAL TERMINALS**

Model 49-1240, Code 124  
 Model 49-1278, Code 123

In some of the first production of the above models, the high-frequency-aerial terminal board is covered by the metal portion of the back cover.

When any of these receivers are encountered in the field, the back cover should be modified as follows:

1. Remove the back cover.
2. Cut a section out of the bottom metal strip large enough to clear the high-frequency-aerial terminal board.
3. Replace the back cover.

Later production of these models have the above modification incorporated.

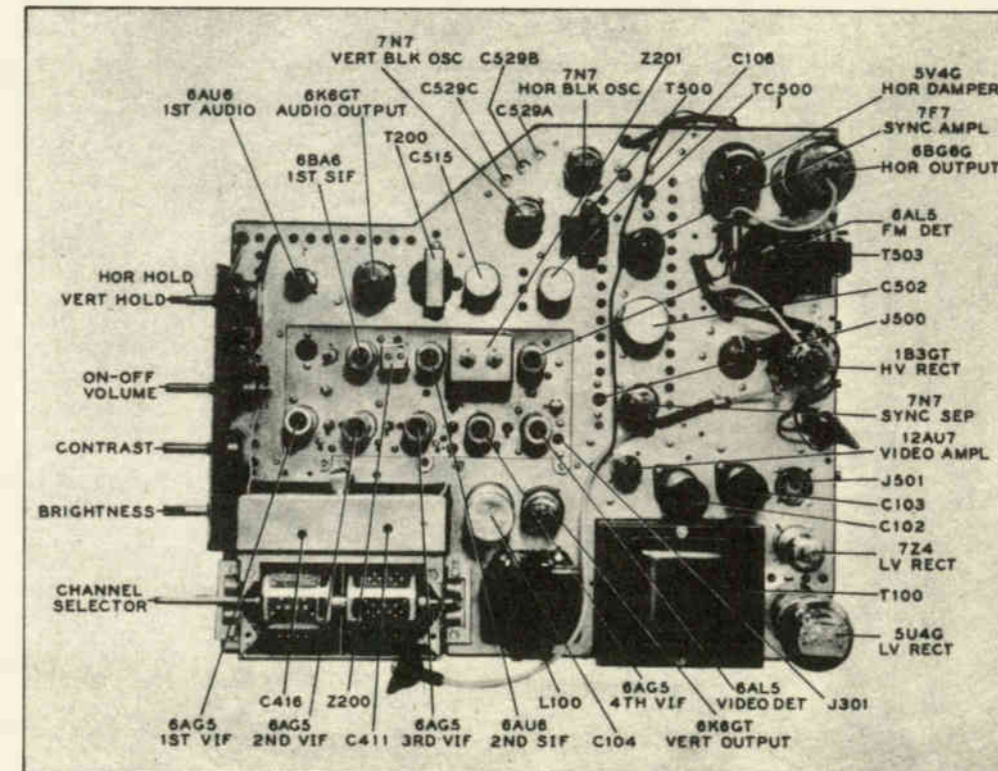

Figure 78. Top View of Chassis

TP-7102B

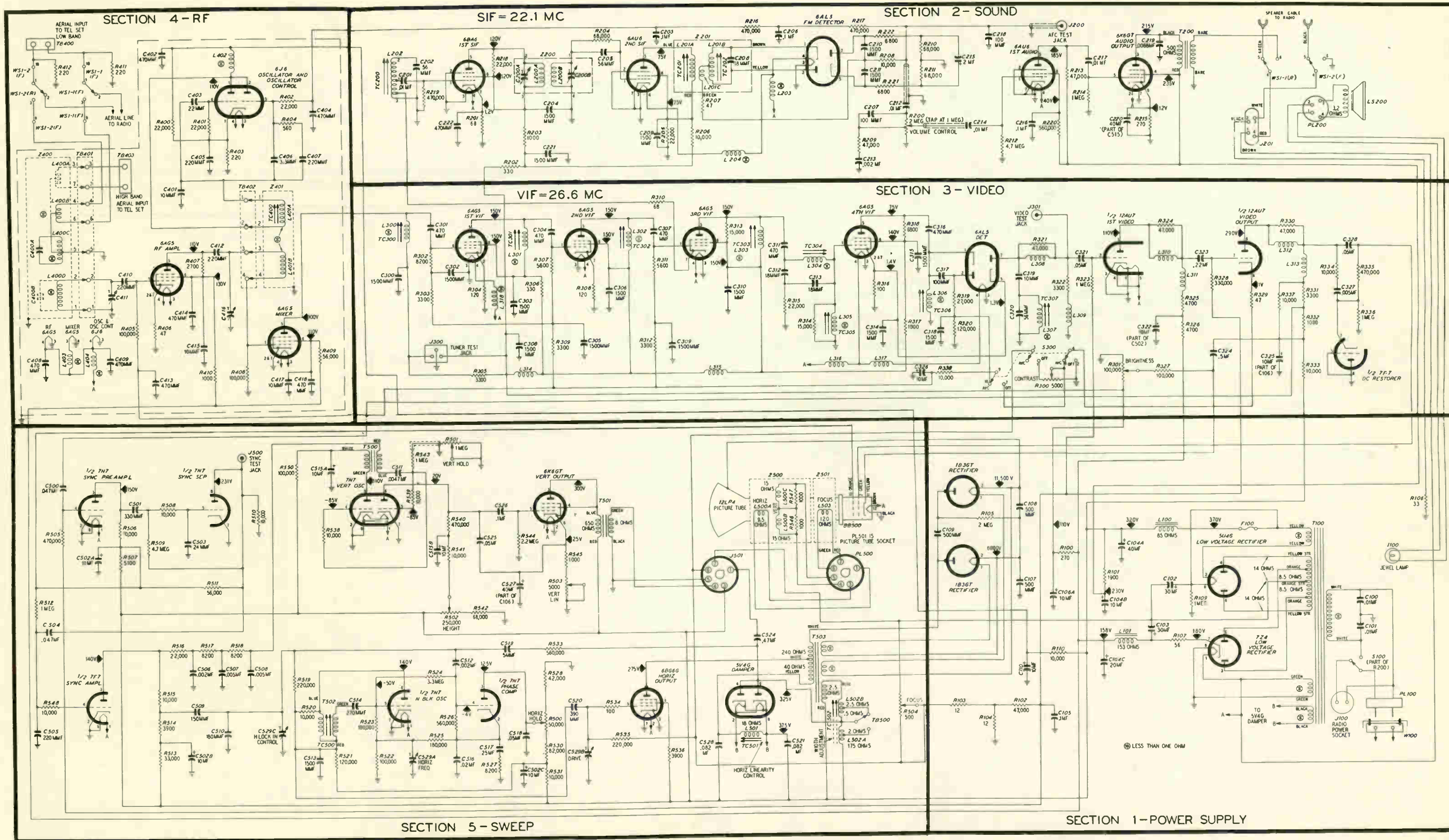
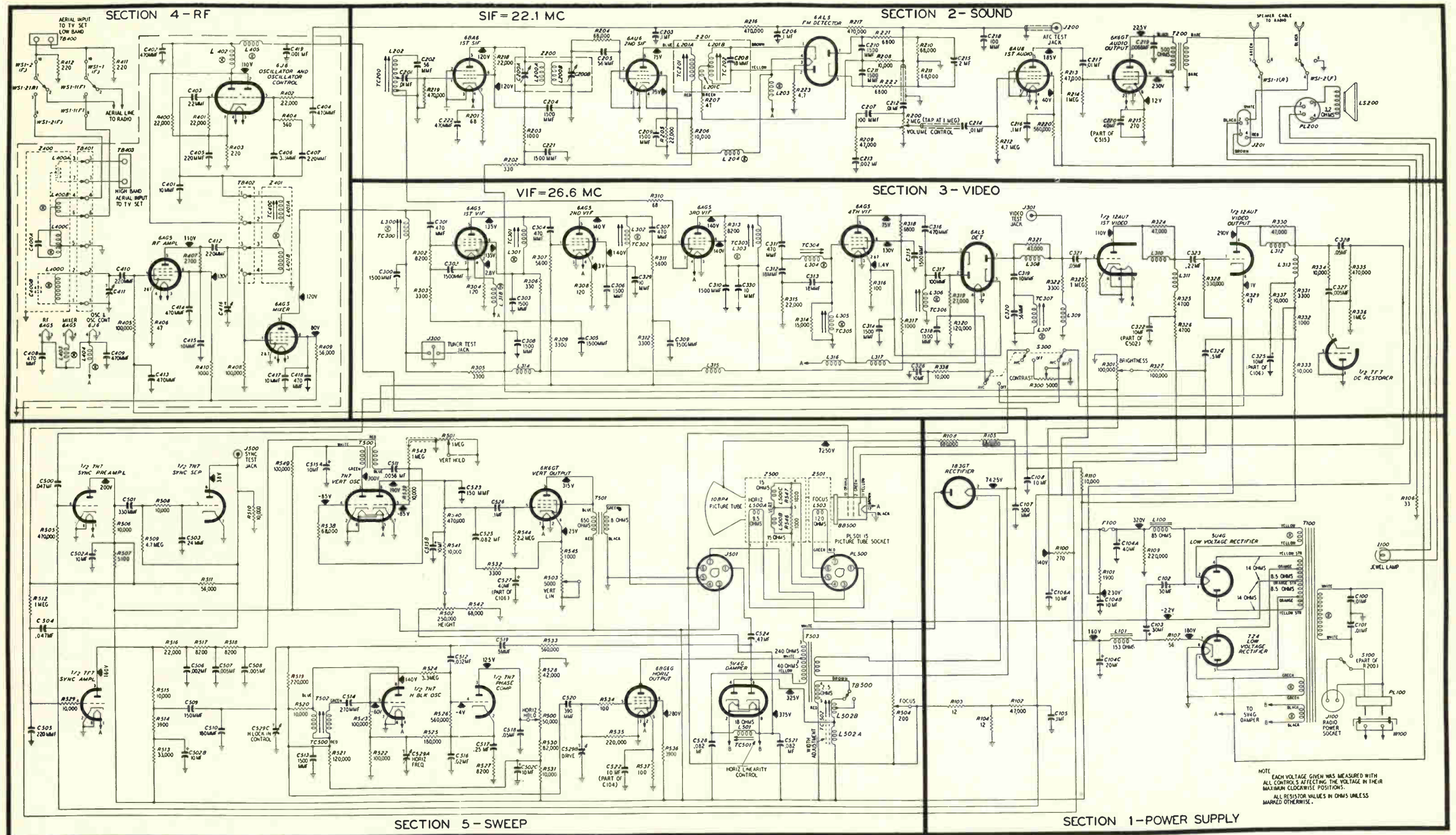

Figure 84. Complete Sectionalized Television Schematic Diagram, Group 2 Models, Showing Test Voltages





SECTION 5 - SWEEP

SECTION 1 - POWER SUPPLY

Figure 102. Complete Sectionalized Television Schematic Diagram, Group 3 Models, Showing Test Voltages

# GROUP 4

MODELS IN GROUP 4A	MODELS IN GROUP 4B	MODELS IN GROUP 4C
49-1450, Code 121	49-1450, Code 123	49-1450, Code 123T
49-1475, Code 121	49-1475, Code 123	49-1475, Code 123T
49-1480, Code 121	49-1480, Code 123	49-1480, Code 123T

## CIRCUIT VARIATIONS

Model 49-1475, Code 121 is a television-radio-phonograph combination with a Model M-9C record changer.

Model 49-1480, Code 121 is a television-radio-phonograph combination with a Model M-12 record changer. The television chassis is identical to that used in Model 49-1475, Code 121.

Model 49-1450, Code 121 is a console television receiver employing a chassis similar to that of Model 49-1475, Code 121. The circuit variations for this model are shown in figures 118 through 122.

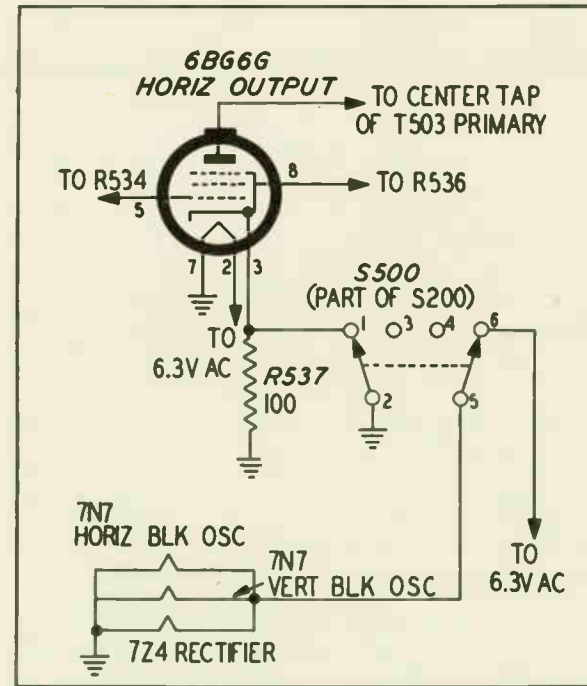

Figure 118. Horizontal-Output Stage and Sweep-Disabling Circuit of Model 49-1450, All Codes

TP-7862

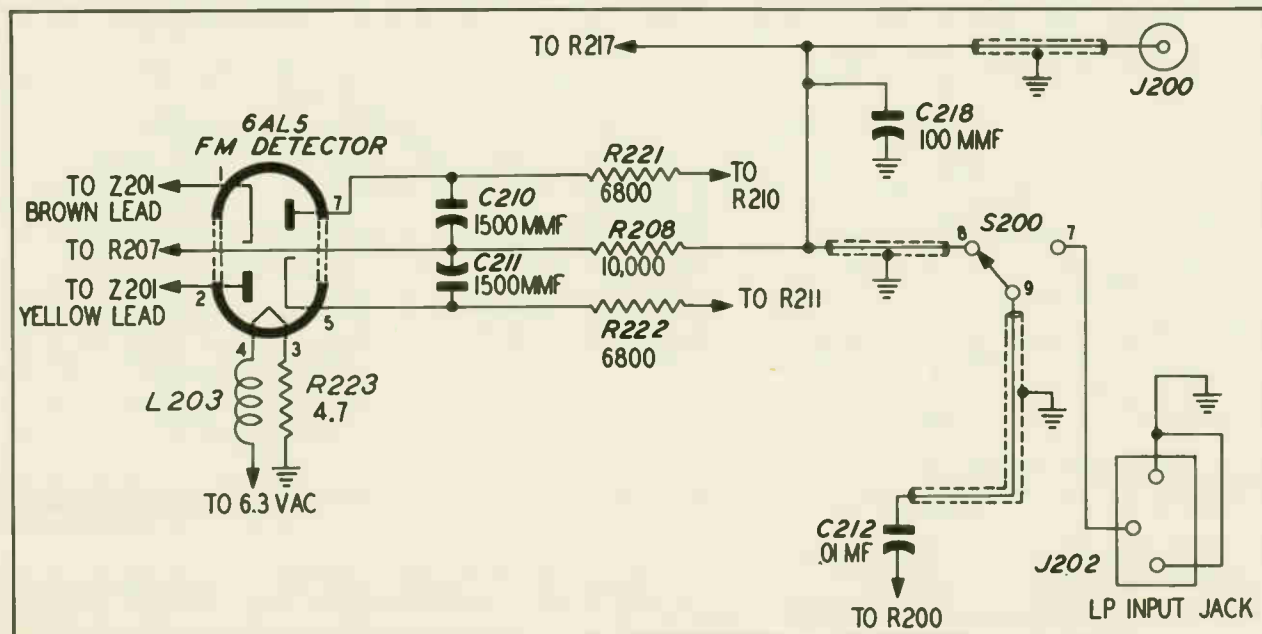
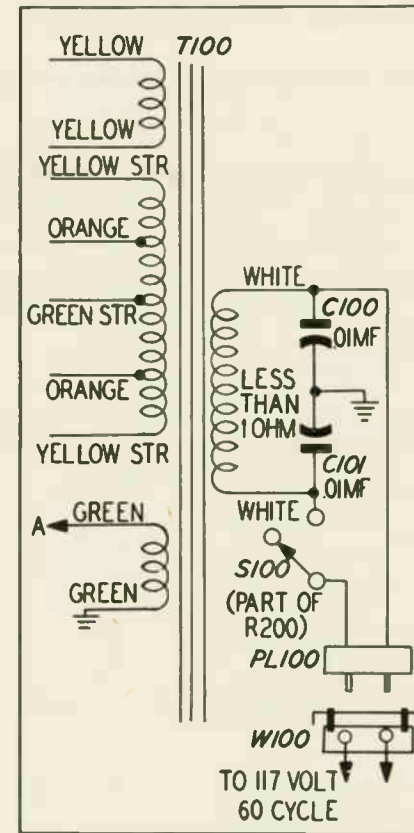

Figure 119. FM-Detector Output Circuit of Model 49-1450, All Codes

TP-7863-1



TP-7857-1

Figure 120. AC Input Circuit of Model 49-1450, All Codes

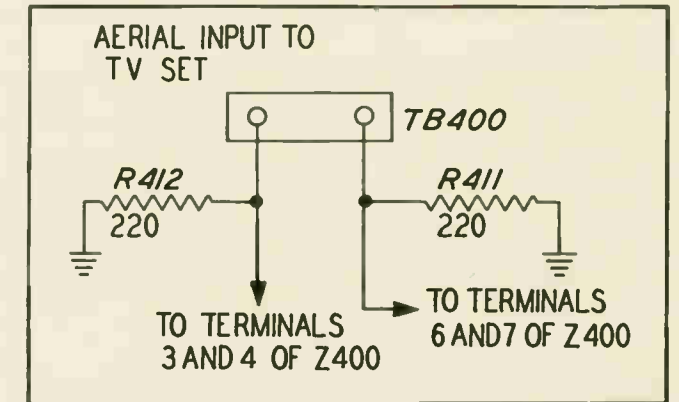

TP-7855

Figure 121. Aerial Input of Model 49-1450, All Codes

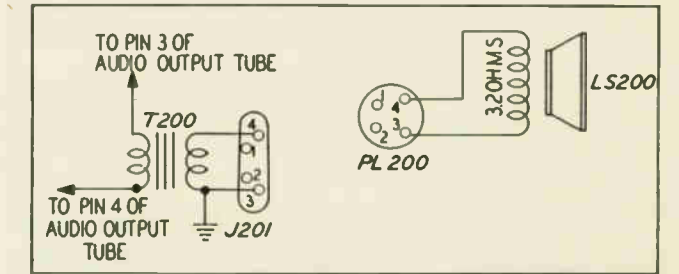

TP-7856

Figure 122. Speaker Circuit of Model 49-1450, All Codes

## PRODUCTION CHANGES

### MODELS 49-1450, 49-1475, AND 49-1480, ALL CODE 121 (MAIN CHASSIS)

RUN NO.	DESCRIPTION OF CHANGE	NEW OR ADDED PART NO.	OLD OR REMOVED PART NO.	REASON FOR CHANGE
2	100,000-ohm resistor added in series with lead between R501 and ground.	66-4108340		To improve vertical-hold range.
3	R536 changed from 10,000 ohms to 3900 ohms. 10,000-ohm DEFLECT. control potentiometer added in series with lead between R536 and B+ supply.	66-2395340 33-5546-18	66-3105340	To make the horizontal-sweep-output range more flexible.

### MODELS 49-1450, 49-1475, AND 49-1480, ALL CODE 123 (TUNER UNIT)

2	L405, r-f choke, added in series with B+ lead to local oscillator, between ungrounded end of C419 and junction of L402 and C402.	32-4112-11		To reduce video modulation in local oscillator.
3	C401 changed to special temperature-coefficient condenser.	30-1224-51	30-1224-39 or 62-010009001	To reduce local-oscillator drift.
4	Mechanical improvements incorporated.	76-5057 (New Part No. of Tuner Unit.)		To improve performance of tuner unit.
5	C406 changed from 3.3 mmf. to 2.2 mmf.	30-1221-4	30-1221	To improve a-i-c range.

### MODELS 49-1450, 49-1475, AND 49-1480, ALL CODE 123 (MAIN CHASSIS)

RUN NO.	DESCRIPTION	NEW OR ADDED PART NO.	REASON FOR CHANGE
2	Aerial terminal boards removed from chassis, and placed over power transformer by means of a bracket assembly. The top terminal board is the low-frequency aerial input, and the bottom terminal board is the high-frequency aerial input.	Back (49-1450) 54-7712-1 Back (49-1475) 54-7713-2 Back-and-cup assembly 76-4470-1	To eliminate spurious pickup.





## GROUP 4B

## CIRCUIT VARIATIONS

Philco Television Receiver Model 49-1450, Code 123, is similar to Model 49-1450, Code 121; and Philco Television-Radio-Phonograph Models 49-1475, Code 123, and 49-1480, Code 123, are similar to Models 49-1475, Code 121, and 49-1480, Code 121, respectively, with the following exceptions and additions:

1. The Code 123 models employ an electronic fine-tuning-control circuit, known as a channel-adjuster circuit.
2. All leads to the CONTRAST control are shielded. The ground side of the CONTRAST control is grounded at terminal 2 of terminal strip B24 near the 5U4G rectifier, instead of being grounded at the same point as the BRIGHTNESS control.
3. R326 is changed from 10,000 ohms to 47,000 ohms.
4. R331 is changed from a 1-watt to a 2-watt resistor.
5. L406, an r-f choke, is added in series with the filament lead to the filaments of Section 4.
6. C523, the 150-mmF. condenser, is not present in the Code 123 models.
7. C525 is changed from .082 mf. to .068 mf.
8. C528 is changed from .082 mf. to .068 mf.
9. R536 is changed from 10,000 ohms to 3900 ohms.
10. R549 is changed from 100,000 ohms to 10,000 ohms.
11. R550, a 470-ohm resistor, is added in series with the lead between C526 and the junction of C525 and R540.
12. R551, a 100,000-ohm resistor, is added in series with the lead between R501 and ground.
13. R552, a 10,000-ohm potentiometer (DEFLECT. control), is added in series with the lead between R536 and B+.
14. The cathode, pin 2, of the vertical-blocking-oscillator tube, and the cathode, pin 2, of the sync-amplifier tube are removed from ground and connected together. R553, a 1200-ohm resistor, and C530, a .1-mf. condenser, are added in parallel between the junction of the two cathodes and ground.
15. The lead between pin 3 of the damper tube and the HEIGHT control is removed. The positive end of the HEIGHT control is connected to the ungrounded end of C515A. The B+ end of R549 is removed from the 320-volt supply and re-connected to pin 3 of the damper tube.

Figure 125 shows the complete sectionalized television schematic diagram for Models 49-1475, Code 123, and 49-1480, Code 123. The circuit variations in figures 119 through 123 show the differences in the circuits of Models 49-1450, Code 123, and 49-1475, Code 123.

## ADDITION OF PHONO SWITCH BOX FOR EXTERNAL RECORD PLAYER

Philco Models 49-1475 and 49-1480, all codes, are equipped with automatic record changer and record player combinations designed with two tone arms and two turntable speeds, for playing either standard or long-playing records. Later production of these models also incorporates a special phono switch box, Philco Part No. 76-4981, which makes it possible to use an external record player, with a turntable speed of 45 r.p.m., in conjunction with the audio amplifier of the radio chassis.

The new phono switch box, shown in figure 124, is mounted inside the record-player compartment in

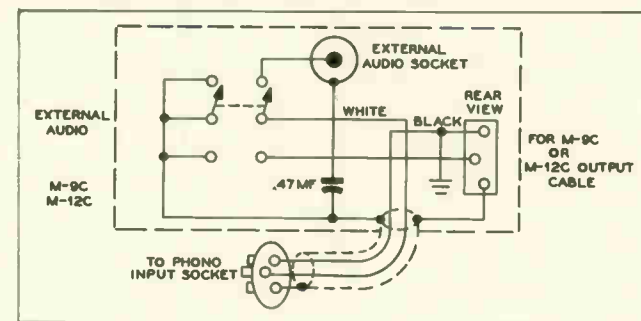

Figure 124. Circuit of Phono Switch Box

the front upper-right-hand corner, under the mounting shelf for the radio chassis.

The output cable from the changer is plugged into the phono switch box, and a cable from the phono switch box is plugged into the phono-input socket of the radio chassis. Another jack on the phono switch box is used for the external record player. A double-pole, double-throw switch switches either the external record player or the automatic record changer and record player combination to the phono input of the radio chassis.

All models using the phono switch box have the letter "P" stamped on the chassis. This switch box is available in kit form under Part No. 45-1645, which includes complete instructions for installation in models which do not already incorporate the modification.

## LOSS OF SYNCHRONIZATION WHEN RECEIVING STRONG SIGNALS

The loss of synchronization, sync distortion, may be due to too high a signal level of the 1st video amplifier (above 6.0 volts peak-to-peak) when the receiver is operated in the AVC ON position. The circuit parameters of the first video amplifier are such as to reduce the effect of noise. This limits the range of grid drive (to 6 volts peak-to-peak) before plate-clipping of the sync signal occurs.

The a-v-c system in Group 4C models is designed to hold the signal applied to the first video amplifier to 6 volts peak-to-peak, or less.

In some cases, the developed a-v-c voltage is not sufficient to hold the signal to 6 volts peak-to-peak, because the 10-mf. a-v-c filter condenser has higher than normal leakage. This allows the first video amplifier to be overdriven.

If this condition is encountered, it is recommended that the a-v-c filter condenser be checked for leakage.

To make the check, unsolder one end of the condenser and measure the leakage with a standard ohmmeter having not more than 9 volts potential in the circuit. Remember to observe the polarity of the electrolytic condenser. The leakage resistance should be 500,000 ohms or more under this low-voltage condition. If the condenser has lower leakage resistance, replace the condenser with one that measures 500,000 ohms or more. The condenser will still probably be good for other applications at its rated voltage.

Leakage of the blocking condensers between the video-i-f plates and the grid of the following stage will also reduce the a-v-c voltage, producing the same symptoms. To check the blocking condensers for leakage, remove the tube following the condenser, and ground the low end of the grid-return resistor. Place a 20,000-ohms-per-volt voltmeter directly across the grid-return resistor. With no signal being received, the voltage should be zero. Any indication of a positive voltage indicates that the blocking condenser is leaky. Replace it with a new one.

GROUP 4C  
CIRCUIT VARIATIONS

The television chassis of Models 49-1450, Code 123T, 49-1475, Code 123T, and 49-1480, Code 123T are similar to Code 123 of these models, with the exception of the following changes in the video-i-f system for Code 123T models:

1. Addition of a new adjacent-sound trap in the plate circuit of the 1st video-i-f amplifier tube.
2. Modification of one of the existing accompanying-sound traps (L307), and making it an adjacent-sound trap.
3. Modification of the existing adjacent-sound trap (L304), and making it an accompanying-sound trap.

These changes were made to provide additional accompanying-sound rejection for reception in areas where the transmitted sound is more powerful than the transmitted video.

A detailed description of the changes is as follows:

1. The lead connecting L301 to the plate (pin 5) of the 1st video-i-f amplifier tube is removed, and the new trap is connected in series. The new coil is mounted adjacent to L301. The adjusting screw for the new trap is TC309, and its location is shown in the illustration showing trimmer locations.

2. The accompanying-sound trap, L307, is modified as follows:

C320 is changed in value from 56 mmf. to 39 mmf. This modification changes the resonant frequency of L307 from 22.1 mc. to 28.1 mc., making it an adjacent-sound trap.

3. The adjacent-sound trap, L304, is modified as follows:

C312 and C313 are changed in value from 18 mmf. to 51 mmf., and R315 is changed in value from 22,000 ohms to 5100 ohms. This modification changes the resonant frequency of L304 from 28.1 mc. to 22.1 mc., making it an accompanying-sound trap.

Chassis having the above changes are identified as Code 123T, run 3.

These changes necessitate a new alignment procedure.

Figure 126 shows the complete sectionalized television schematic diagram for Model 49-1475, Code 123T, and Model 49-1480, Code 123T. The circuit variations in figures 119 through 123 show the differences in the circuits of Models 49-1450, Code 123T, and Model 49-1475, Code 123T.

## PRODUCTION CHANGES

## MODELS 49-1450, 49-1475, AND 49-1480, ALL CODE 123T (MAIN CHASSIS)

RUN NO.	DESCRIPTION	NEW OR ADDED PART NO.	REASON FOR CHANGE
4	3300-ohm resistor added in parallel with CONTRAST control.	86-2338340*	To improve resolution by modifying contrast range.

NOTE: There was no run 2 or run 3 in these models.



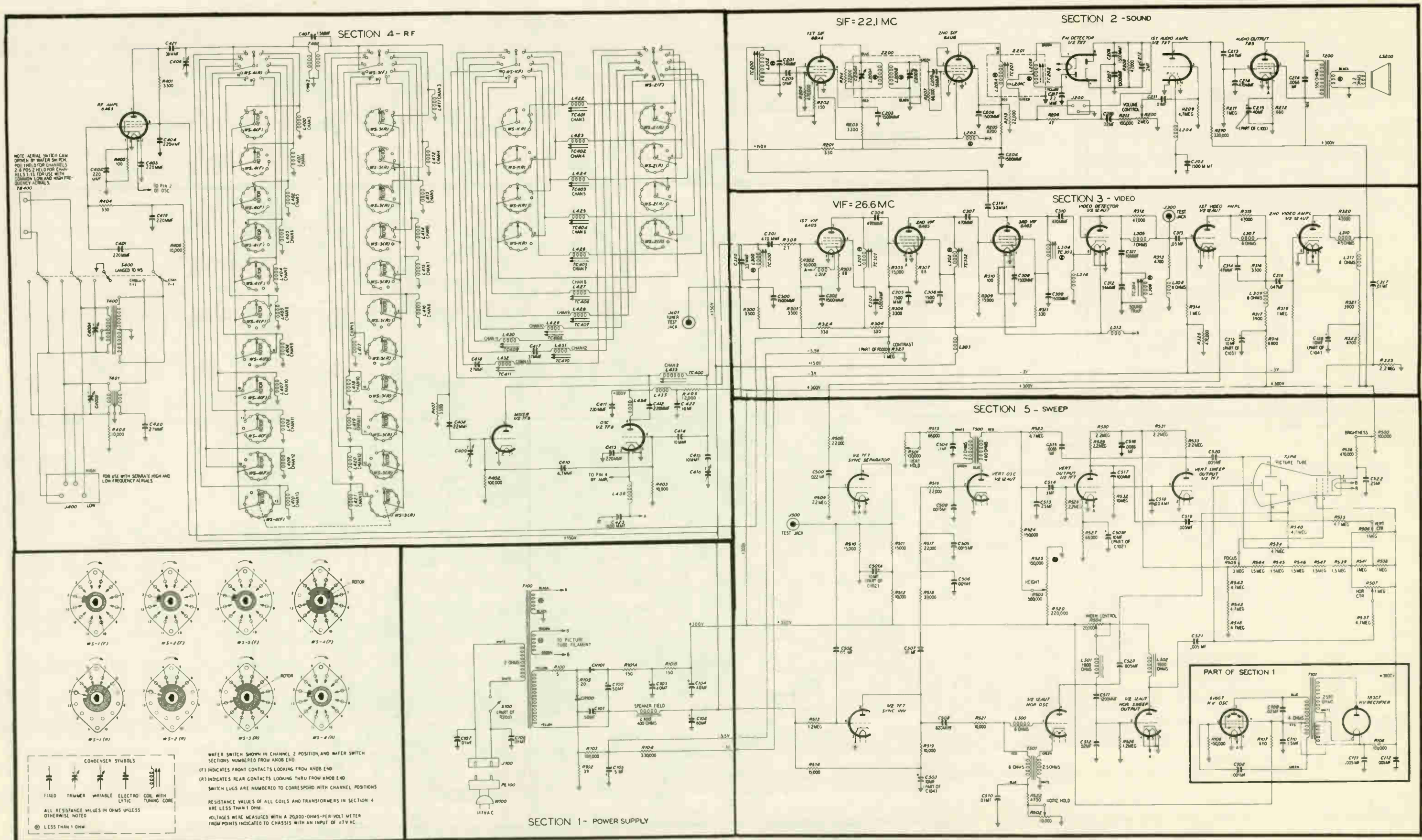

Figure 128. Complete Sectionalized Schematic Diagram of Model 49-702

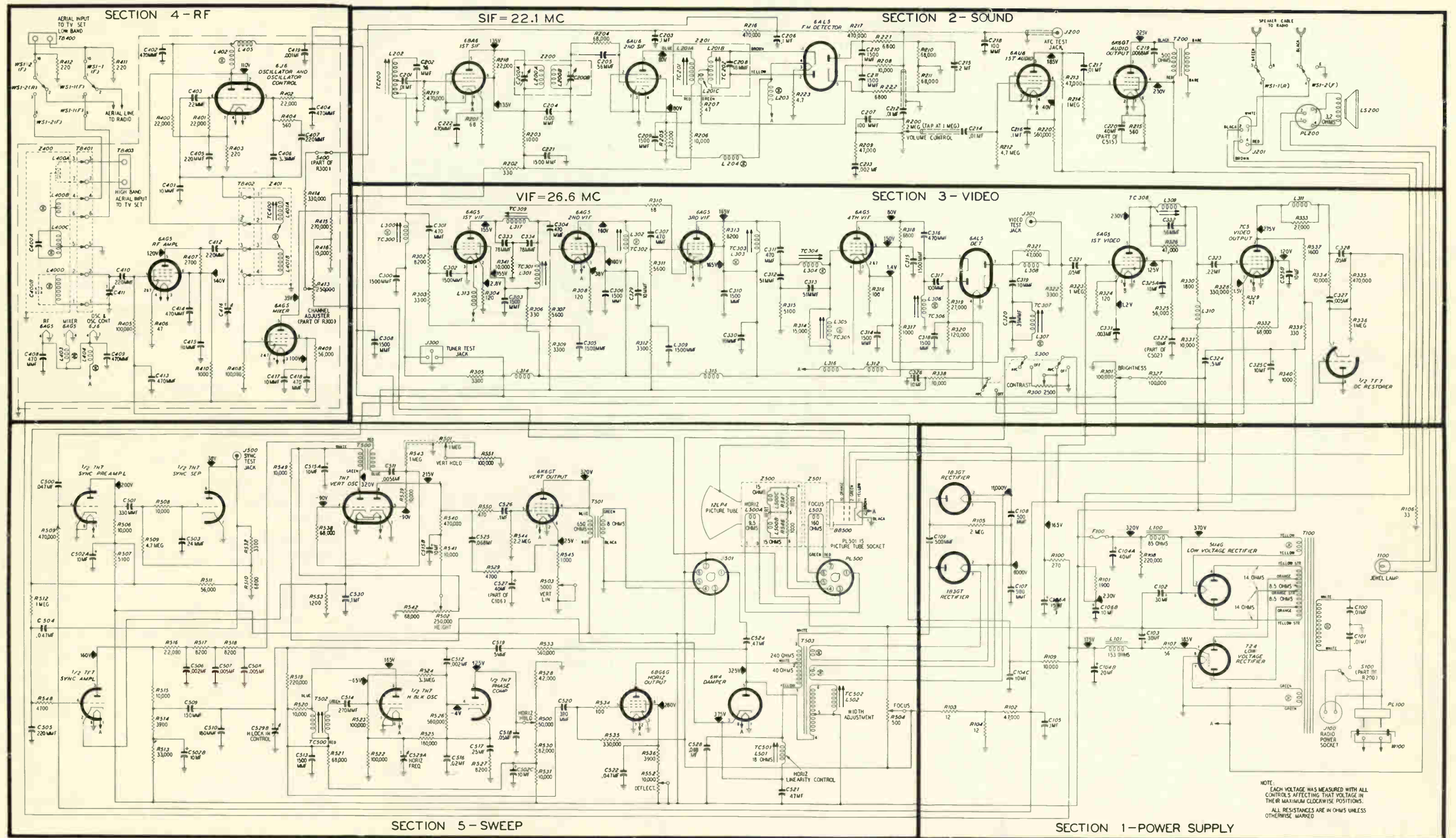

Figure 126. Complete Sectionalized Schematic Diagram, Model 49-1475, Code 123T, and Model 49-1480, Code 123T

**PRODUCTION CHANGES**

RUN NO.	DESCRIPTION OF CHANGE	NEW OR ADDED PART NO.	OLD OR REMOVED PART NO.	REASON FOR CHANGE
3	R906 changed from 15,000 ohms to 33,000 ohms.	66-3333340	66-3153340	To improve AM sensitivity.
3	R801 changed from 68,000 ohms to 10,000 ohms.	66-3103340	66-3683340	To improve AM sensitivity.
3	R908 changed from 2200 ohms to 1500 ohms.	66-2153340	66-2223340	To improve AM sensitivity.
4	25-ohm resistor between CR600 and B- bus removed. Negative lead of CR600 connected to B- bus.		33-1334-5	To increase voltage output.
4	R603 changed from 25 ohms to 50 ohms, 7 watts.	33-1335-84	33-1334-5	To decrease surge currents.
4	CR600 and CR601 changed to more efficient rectifiers.	34-8003-2	34-8003-1	To increase efficiency.
5	C900 changed to lower-drift condenser.	31-2724-7	31-2724-3	To reduce frequency drift on FM band.
6	C920 changed from 100 mmf. to 220 mmf.	62-122001001	62-110009001	To improve FM sensitivity.
6	R800 changed from 33,000 ohms to 10,000 ohms.	66-3103340	66-3333340	To improve FM sensitivity.
6	R808 changed from 1000 ohms to 10,000 ohms.	66-3103340	66-2103340	To improve FM sensitivity.
6	2200-ohm resistor in B+ lead from positive end of C606C removed. Positive end of C606C connected to junction of R804 and R808.		66-2224340	To improve FM sensitivity.
6	C708, 51-mmf. ceramic condenser, added between grid and cathode of first audio-amplifier tube.	30-1224-2		To improve FM sensitivity.
6	R903 changed from 4700 ohms to 10,000 ohms.	66-3103340	66-2473340	To improve FM sensitivity.
7	220-mmf. condenser added between pin 8 of output tube and B- bus.	62-122001001		To prevent oscillation of the output stage.
8	.01-mf. condenser added between pin 3 of first i-f amplifier tube and B- bus.	61-0120		To prevent oscillation of i-f stage during FM operation.
9	R601 changed from 2200 ohms to 10,000 ohms.	66-3104340	66-2224340	To improve voltage regulation and prevent oscillation of output stage.
9	R601 disconnected from positive end of C606C and reconnected to positive end of C606B.			To improve voltage regulation and prevent oscillation of output stage.
9	680-ohm resistor added in lead between R600B and positive end of C606C.	66-1684340		To improve voltage regulation and prevent oscillation of output stage.
9	220-mmf. condenser that was added in run 7 disconnected from pin 8 of output tube and reconnected to pin 4.			To prevent oscillation of output stage.
10	C707 disconnected from B+ lead to output stage and reconnected to B- bus. 220-mmf. condenser that was connected to pin 4 of output tube in run 9 disconnected from pin 4 and reconnected to pin 8.			To prevent oscillation of output stage.
11	Z800 changed to an i-f transformer with greater gain.	32-4372	32-4257	To improve FM performance.
11	Z802 changed to an i-f transformer with greater gain.	32-4372-1	32-4257-1	To improve FM performance.

**PRODUCTION CHANGES**

RUN NO.	DESCRIPTION OF CHANGE	NEW OR ADDED PART NO.	OLD OR REMOVED PART NO.	REASON FOR CHANGE
11	.01-mf. condenser added between B- and ground, in parallel with C824. .01-mf. condenser that was added in run 8 disconnected from pin 3 of first i-f amplifier tube and reconnected to pin 4.	61-0120		To prevent oscillation of i-f stages during FM operation.
11	C922 changed from .03 mf. to .02 mf.	61-0119	45-3500-1	To improve FM performance.
11	R909 and B- lead to C921 removed. Ungrounded end of C921 connected to B- at junction of R806 and C824.		66-0688340	To improve FM performance.
12	R600 changed from two sections of 180 ohms and 2500 ohms, to two sections of 180 ohms and 3200 ohms. 680-ohm resistor that was added in run 9 removed. R600B reconnected to the ungrounded end of C606C.	33-3435-23	33-3435-17 66-1684340	To combine two resistors in one unit.
13	2.2-mf. condenser added between pin 1 of FM-AM detector and B- bus.	30-1221-4		To improve FM tuning.
14	Connections to secondary winding of Z801 reversed.			To prevent oscillation of i-f stages during AM operation.
14	C816 changed to condenser of higher voltage rating.	61-0120	30-4575	To reduce the number of condenser failures.
14	R909 removed and replaced with r-f choke.	32-4143-4	66-0688340	To prevent oscillation during AM operation.
14	C922 changed from .02 mf. to .03 mf.	45-3500-1	61-0119	To improve FM performance.
15	100-mmf. condenser added between ground and B- bus at junction of R806 and terminal 2 of Z803.	5-62-110001001		To stabilize FM performance.
15	100-mmf. condenser added across C806.	5-62-110001001		To stabilize FM performance.
15	100-mmf. condenser added between pin 4 of AM-FM detector and ground.	5-62-110001001		To stabilize FM performance.
15	100-mmf. condenser added between B- bus at C827 and junction of R813 and FM terminal of WS2-1 (R).	5-62-110001001		To stabilize FM performance.
15	100-mmf. condenser added between pin 7 of 1st audio amplifier and ground.	5-62-110001001		To stabilize FM performance.
15	C820 removed.		62-110001001	To stabilize FM performance.
15	B- lead from ungrounded end of C921 to choke, added in run 14, removed. 68-ohm resistor added between ungrounded end of C921 and junction of L909 and C922.	66-0688340		To improve FM performance.
15	L909 changed to improved coil.	32-4089-3	32-4081-2	To provide better r-f isolation.

**SERVICE HINTS**

**HUM MODULATION ON AM-FM RECEPTION**

Hum modulation on AM or FM reception may be caused by leakage of the filament-to-B-minus by-pass

condensers in the radio chassis. If this condition is encountered, it is suggested that these condensers be checked for leakage, and replaced if necessary.

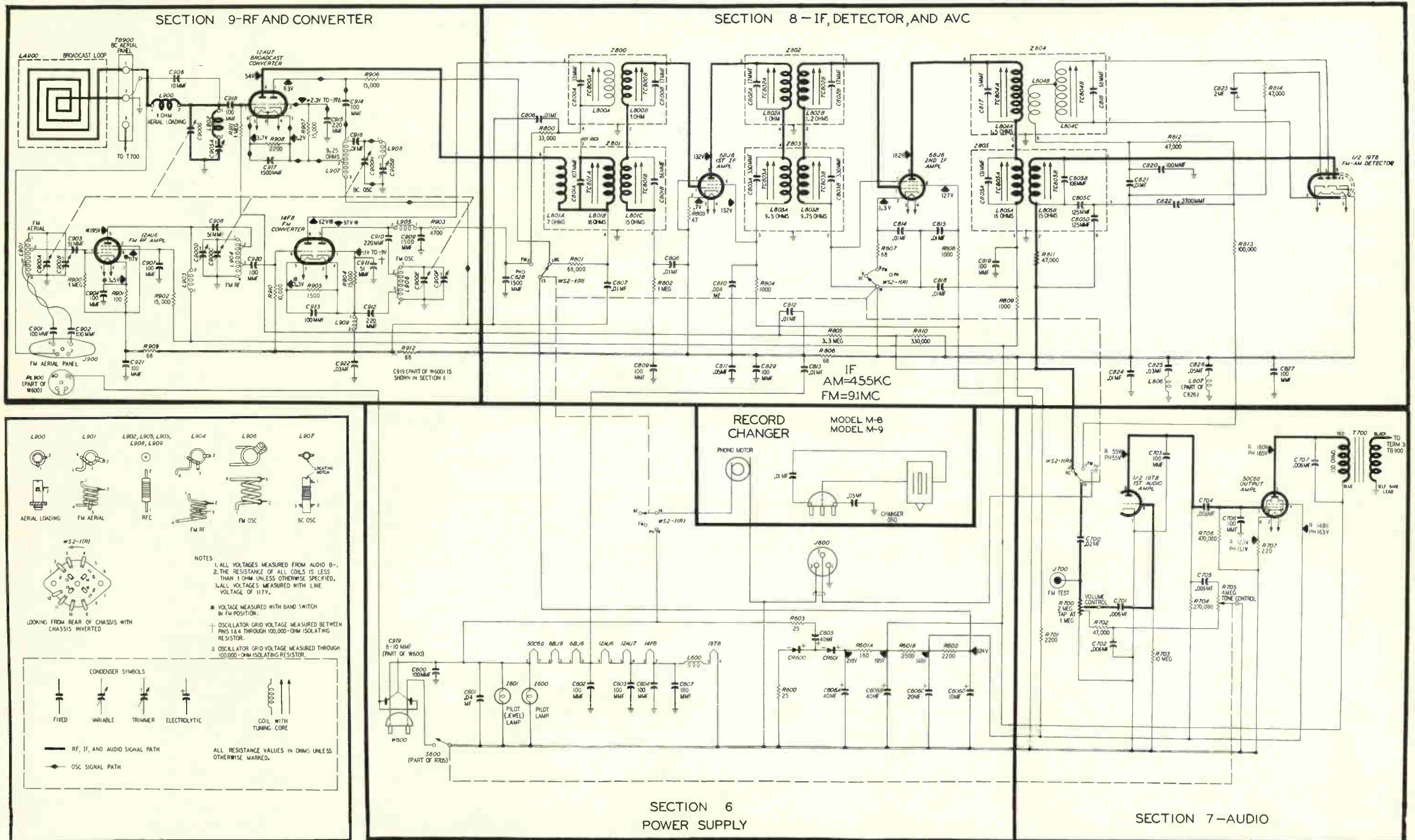

Figure 133. Complete Sectionalized Radio Schematic Diagram, Showing Test Voltages

## IMPROVING RECEIVER PERFORMANCE IN FRINGE AREAS

A television receiver is designed for operation with signal levels which differ considerably. In so-called "fringe" areas, the signal-to-noise ratio, as indicated by the amount of "snow", and the general sync performance, can be improved by several modifications which can be incorporated into a receiver.

### REMOVAL OF A-G-C VOLTAGE FROM R-F AMPLIFIER

An improvement in signal-to-noise ratio, which has more apparent effect in the semi-fringe, rather than the extreme fringe area, can be made by removing the a-g-c voltage that is applied to the r-f-amplifier grid, and returning the grid-leak resistor directly to ground. The r-f-amplifier circuits used in Philco Tuners Part No. 76-5433 and 76-4402 are shown in figure 7. The removal of a-g-c voltage allows the r-f amplifier to operate at maximum gain, thus increasing the r-f signal voltage to the mixer. In the extreme fringe areas, where little or no a-g-c voltage is developed, because of the relatively weak signal, this modification will not cause too much improvement in signal-to-noise ratio. If the TB-2 Booster is used in conjunction with this modification, improved reception will result, even in an extreme fringe area. Ordinarily, when a booster is used in the extreme fringe area, the additional preamplification of the signal results in a proportionate increase in a-g-c voltage. This added bias reduces the gain of the r-f stage, causing a proportionate decrease in signal-to-noise ratio. When the a-g-c voltage is removed from the r-f amplifier, the added preamplification of the booster, plus the full gain of the r-f stage, combine to permit the best "snow-free" reception. If a booster with a poor noise figure is used, the modification will result in a stronger signal, but there will be no appreciable reduction in snow.

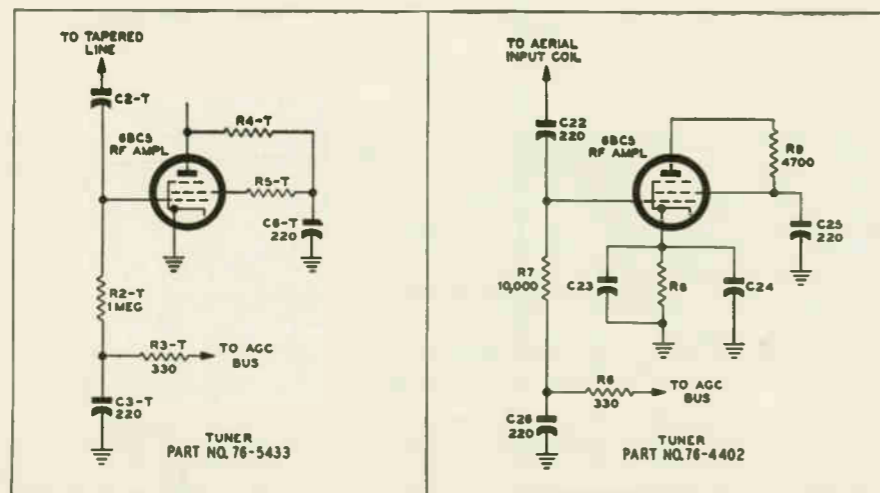

Figure 7. A-G-C Circuit Details of Philco Tuners Part No. 76-5433 and 76-4402.

### MODIFICATION OF SYNC PRE-AMPLIFIER

Another simple modification, which is accomplished by decreasing the plate voltage on the sync preamplifier stage, will improve sync performance in extremely noisy areas. The reduction in plate voltage causes negative-peak clipping on signals of lower amplitude. Since the composite video signals are negative at the grid of this stage, the change permits noise clipping closer to the sync tips on weak signals. The plate voltage is reduced by inserting an adequately dropping resistor on the B+ side of the plate load resistor. This circuit is shown in figure 8. The value of the resistor can be determined experimentally by observing the clipping action on a scope connected to the preamplifier output. A plate-voltage reduction of 15 to 20 volts is usually sufficient to give better operation under noise conditions.

### MODIFICATION OF VIDEO-DETECTOR AND VIDEO-AMPLIFIER LOADS

Greater video gain may be obtained in fringe areas by modifying the output loads of the video detector and video amplifier. As shown in figure 9, a 2400-ohm resistor may be added in series with R46, to increase the value of the detector load to 4800 ohms. This change provides a greater level of signal for the first video amplifier. In the 50-T1400 series, Code 125, Run 6, the 2200-ohm video amplifier plate load resistor and 470- $\mu$ f. shunt condenser may be shorted out. The 3900-ohm plate resistor, in series with the peaking coil, may be increased to 5700 ohms by adding a series 1800-ohm resistor (figure 9). The video output plate load resistor

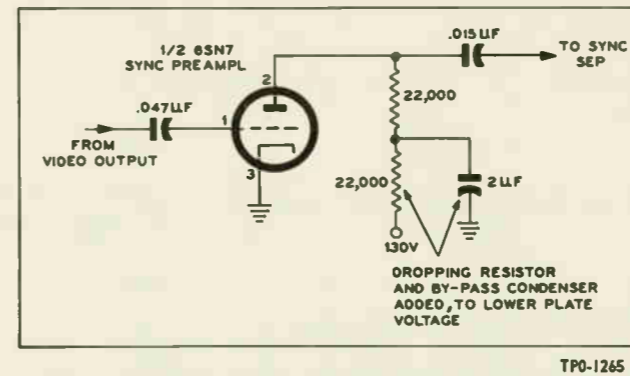

Figure 8. Modification of Sync Preamplifier

may be increased to 3300 ohms. See figure 10. These video changes increase the video gain and low-frequency response of the system at a sacrifice in bandpass, so that the picture presentation and snow appearance is greatly improved. Again it should be emphasized that this is a fringe-area change. It is not recommended in strong or medium signal areas.

### REMOVAL OF GAMMA-CONTROL RESISTOR

Another change which can be made is the removal of the "gamma-control" resistor, 22,000 ohms, from screen to ground of the video-output tube. This change gives a considerable amount of extra drive to the picture-tube grid, and consequently, a much blacker picture. In 50-T1400-series receivers of a code and run earlier than Code 125, Run 6, where the sync take-off is from a tapped portion of the plate load of the video-output tube, removing the gamma-control resistor and increasing the value of the plate load may produce sync clipping, and thus deteriorate the general sync performance. This change makes the sync performance extremely dependent upon the position of the contrast control. If, in conjunction with the gamma change and video

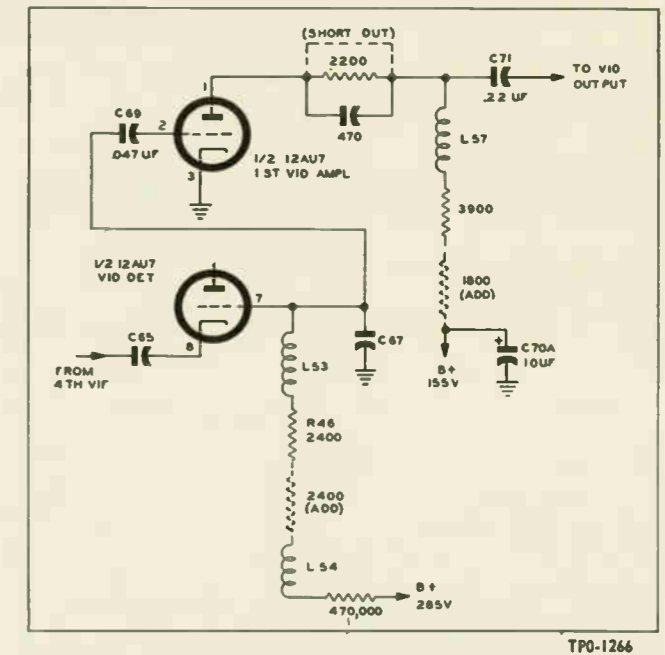

Figure 9. Modification of Video Detector and First Video Amplifier

changes, the sync take-off point is moved to the video detector, good sync performance is obtained (see figure 10). However, moving the sync take-off to the video detector may deteriorate sync performance under noisy conditions in two ways. First, the level of signal fed to the sync preamplifier is lower; this reduces the clipping effect obtained there. Second, any clipping effect previously obtained in the video amplifiers is also lost.

### REDUCTION OF A-G-C VOLTAGE

In fringe areas, the greater portion of the a-g-c voltage is developed by noise; consequently, loss of gain during bursts of noise often results in loss of sync. The effect of noise on the gain of the receiver may be re-

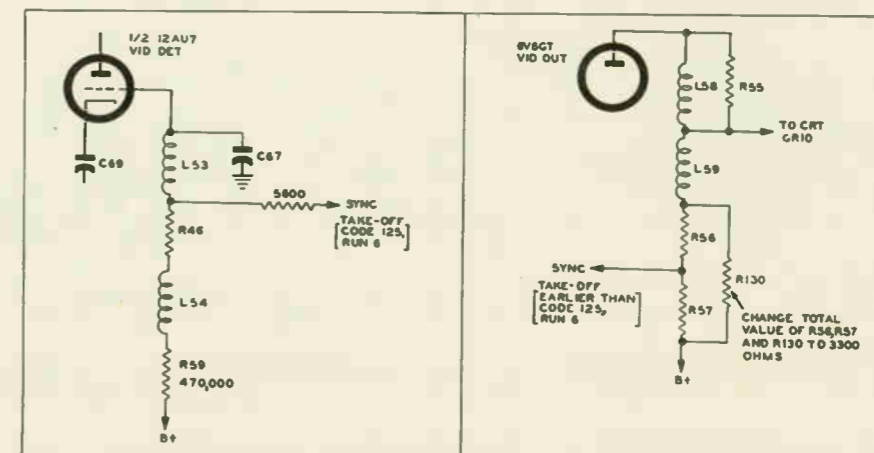

Figure 10. Sync Take-off Change



duced by lowering the a-g-c voltage applied to the video-i-f amplifiers. This is done by connecting a 220,000-ohm resistor between the a-g-c bus and ground. See figure 11. This resistor and the a-g-c filter resistor constitute a voltage divider. A single-pole, single-throw switch should be connected, as shown, to switch the voltage divider in and out of the circuit. When more a-g-c action is required, for strong signals, the switch should be placed in the open, or normal, position.

If the fringe area is very noisy, good noise-clipping must be obtained to maintain sync performance. This may be done by removing the a-g-c voltage from the 3rd v-i-f amplifier, thus allowing this stage to be driven very hard. In the 50-T1400-series receivers, this may be done by removing the 3rd v-i-f grid-return resistor (5600 ohms) from the a-g-c bus, and connecting it to ground.

A kit is available which accomplishes the above a-g-c changes, and incorporates a FRINGE-NORMAL switch, to make the system more versatile.

### I-F ALIGNMENT IN FRINGE AREAS

The i-f alignment of receivers that are used in extreme fringe areas is most important. In the very weak signal areas, where little or no a-g-c voltage is developed, and only a small signal appears at the video detector, the v-i-f alignment should be checked and corrected with no a-g-c voltage applied to the grids, and the adjustment should be made for an output reading of approximately .5 volt, peak to peak, measured at the video detector. Under these conditions, the v-i-f carrier at 26.6 mc. should be placed at approximately 65% of maximum, and the response curve should maintain the same bandpass and amplitude, even when the sweep-input level is further reduced and the curve disappears into the "grass." Any tendency for the i-f system to be regenerative will be indicated by a "peaking" of the curve as the sweep output is gradually reduced. If the proper alignment techniques are used (proper bonding, jigs, etc.), the peaking can be eliminated by careful re-adjustment of the i-f slugs. It is not desirable to reduce the i-f bandwidth to less than 2.5 mc., or to place the v-i-f carrier higher than 65%, since this practice usually results in a very smeary picture, with an accompanying, and more objectionable, type of smeary snow. The bandwidth, as measured from the 65% v-i-f carrier to the 50% point of the low-frequency side of the i-f curve, is an approximate figure, and, on some i-f systems, the exact curve will be extremely difficult to obtain. However, the position of the v-i-f carrier at 26.6 mc. is extremely important, and should be placed accurately on the curve. The desired response curve for fringe areas is shown in figure 12.

### R-F ALIGNMENT IN FRINGE AREAS

Another field expedient sometimes used in fringe areas is to adjust the trimmers of the r-f amplifier and mixer for maximum response on a station signal. This is accomplished by connecting a vacuum-tube voltmeter to the a-g-c bus, and adjusting the trimmers for maximum a-g-c voltage. While this procedure is effective

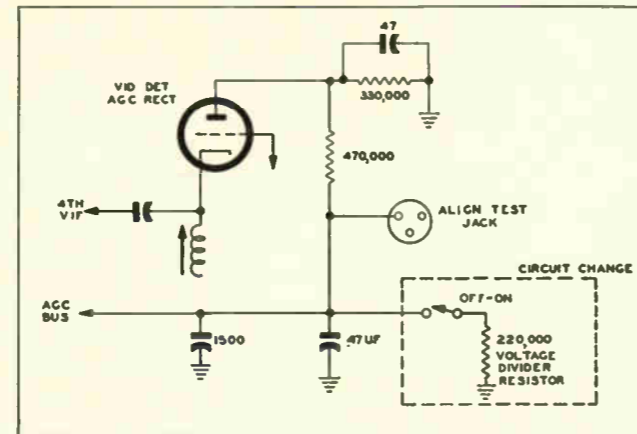

Figure 11. Addition of A-G-C Voltage Divider

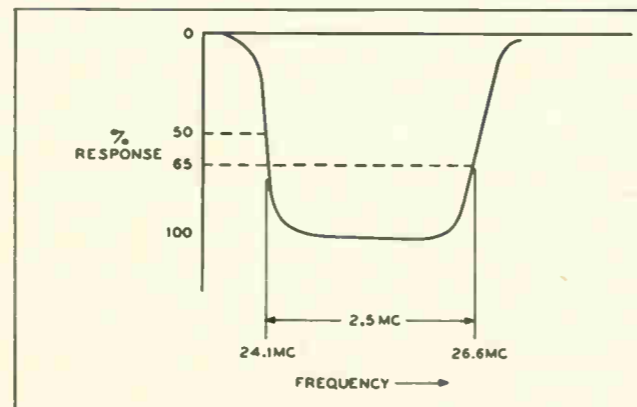

Figure 12. Video-I-F Response of I-F System, After Realignment for Fringe-Area Reception

in areas where only one channel is received, it may lead to difficulty in multi-channel areas. Therefore, if some other channel is noticeably impaired by these adjustments, the tuner will have to be aligned by adjusting the inductance of the coil on each channel, using a sweep generator and an oscilloscope. Normally, this is only necessary in exceptional cases.

### REPLACEMENT OF TUBES IN TUNER

Care should be exercised when changing tubes in a tuner, particularly in the fringe areas, since the inter-electrode capacitance of the original tube may be different from that of the replacement. When a replacement tube is necessary, three or four tubes should be tried, and the one chosen should give optimum performance, as far as sensitivity and bandpass are concerned. This does not mean that the other tubes are bad, but simply, that the replacement tube has characteristics more closely approaching those of the original tube. While the adjustment of the tuner trimmers for

peak a-g-c voltage may not be the recommended bench procedure, it is, nevertheless, a field expedient which is practical without the use of test equipment.

### SELECTION OF AERIALS

Although the various suggestions given above will improve the fringe-area performance of a receiver, it is important to realize that there is no substitute for adequate input signal at the aerial terminals. Here are some things to keep in mind when selecting an aerial.

1. In a single-channel location, the advantages of a sharply tuned aerial should be exploited. The stacked yagi is the best performer under these conditions.

2. In a two or three channel fringe area, consideration should be given to the use of two yagi-type antennas, tuned to individual channels. The additional cost and labor involved may be well worth the trouble. However, if cost is an object, the stacked biconical aerial is a good broad-band performer.

3. An area receiving four or more channels should find the stacked biconical aerial the best all-round performer, but the possibility of using a separate yagi-type aerial for the weakest of the channels should be kept in mind.

## INTERFERENCE (BEAT) DUE TO SOUND AND VIDEO DETECTOR RADIATION — ALL MODELS

When a signal is applied to a nonlinear device, such as a detector, harmonics of the signal are produced. In a television receiver, this condition exists in the video and sound detectors. Certain harmonics of the video i.f. and sound i.f. (see Chart 5) fall within the r-f bandpass limits of a particular channel. These harmonics, which radiate from the detectors, are picked up by the r-f input circuit and are amplified and mixed with the incoming signal, thus causing an interfering beat.

Every known precaution has been taken to reduce the effect of i-f harmonic beats in Philco Television Receivers. However, under certain conditions, and on some channels, harmful effects may occur as a result of these beats.

The best field expedient is to move the intermediate frequency of the receiver, so that the harmonics radiated from the detector fall outside the r-f bandpass of the channel.

Chart 5 shows the channels where it is possible to have harmonics of the video and sound i-f carrier occur in the r-f bandpass, and also shows the frequency to which the i.f. should be moved, to make the harmonic fall outside the r-f bandpass of the particular channel.

It is generally recommended that, in non-intercarrier receivers, both the sound i.f. and video i.f. be shifted, using regular alignment equipment. However, if the signal strength is moderately high, it is only necessary to shift the sound i.f.; of course, when the oscillator frequency is corrected to correspond, this establishes a

new video-i-f carrier frequency. The amount by which the sound i.f. can be shifted without changing the video-i-f alignment depends mainly upon the signal strength.

In low-signal areas, it is permissible to move the sound i.f. lower in frequency by as much as 500 kc., without changing the video-i-f alignment. Moving the sound i.f. higher usually requires realignment of the video i.f. However, in good signal areas, it is often possible to move the sound i.f. higher by as much as 150 kc. without changing the video-i-f alignment.

By means of the following procedure, the sound i.f. of the receiver may be shifted in the home, using only the station signal and a voltmeter:

1. Connect a 20,000-ohms-per-volt voltmeter to the FM TEST jack, so that the FM crossover may be observed (refer to specific service manual).
2. Tune in the station on which the beat occurs, adjusting the FINE TUNING control for best sound.
3. Tune the FINE TUNING control until the beat disappears.
4. Leave the FINE TUNING control in this position, and readjust the FM detector secondary for zero voltage indication on the meter.
5. Tune the FM detector primary and other FM transformer adjustments for maximum output.
6. Check the position of the FINE TUNING control on each channel, and re-center by adjusting the oscillator slugs, if necessary.

CHART 5

### I-F ALIGNMENT CHANGES TO ELIMINATE DETECTOR RADIATION INTERFERENCE (BEAT)

CHANNEL OF POSSIBLE INTERFERENCE	SOUND-I-F BEAT (Caused by harmonic of 22.1 mc.)			CHANNEL OF POSSIBLE INTERFERENCE	VIDEO-I-F BEAT (Caused by harmonic of 26.6 mc.)		
	HARMONIC	NEW SOUND I.F.	NEW VIDEO I.F.		HARMONIC	NEW SOUND I.F.	NEW VIDEO I.F.
4 (86—72 mc.)	3rd (66.3 mc.)	21.9 mc.	28.4 mc.	5 (76—82 mc.)	3rd (79.8 mc.)	20.8 mc.	25.3 mc.
7 (174—180 mc.)	8th (176.8 mc.)	21.7 mc.	26.2 mc.	9 (188—192 mc.)	7th (186.2 mc.)	22.07 mc.	26.57 mc.
11 (198—204 mc.)	9th (198.9 mc.)	22.0 mc.	26.5 mc.	13 (210—216 mc.)	8th (212.8 mc.)	21.75 mc.	26.25 mc.

## SERVICE HINTS

### MODELS 50-T1104, CODE 122, AND 50-T1105, CODE 122 — BUILT-IN AERIAL LEAD DRESS

In some cases, improper performance of the built-in aerial may be traced to the way the lead from the built-in aerial to the aerial-input terminals is dressed. This lead should be kept away from the end of the dipole element nearest the power transformer, and dressed so that it is entirely in the clear.

### ALL MODELS—BUILT-IN AERIAL PERFORMANCE ON CHANNEL 6

To make the built-in aerial matching system tune more sharply on Channel 6, one of the dipole elements was shortened. This change does not affect the reception of the built-in aerial on the other television channels. This change voids previous information stating that the built-in aerial tunes on all channels except 6.

### ALL 10", 12", AND 16" MODELS — CRT AND DEFLECTION-YOKE EXTENSION CABLES

To greatly facilitate service bench work, CRT and deflection-yoke extension cables may be prefabricated from the following Accessory parts:

1. Deflection plug and cable assembly, Part No. 41-3860-6  
Octal Socket and Cable, Part No. 41-3777
2. CRT cable and socket assembly, Part No. 41-3772  
CRT plug, Part No. 54-4571-1

This cable is approximately 28" long.

### MODEL 50-T1400 SERIES, RUNS 1 AND 2 — REDUCTION OF VERTICAL JITTER

Vertical jitter in the picture due to line voltage fluctuations in the above models may be greatly reduced or eliminated, in the special cases where necessary, by adding an extra filter network to the B supply feeding the vertical oscillator and discharge tube. This network consists of a 10,000-ohm resistor and a 10- $\mu$ f. condenser. The circuit is shown in figure 7,

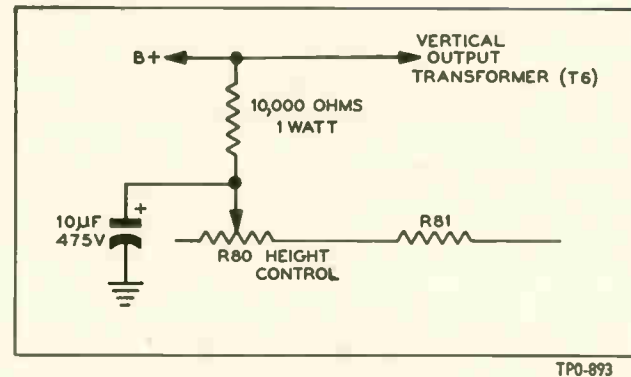

Figure 7. Addition of Filter Network, Model 50-T1400 Series, Runs 1 and 2

### MODEL 50-T1400 SERIES PREVENTING HORIZONTAL-SYNC TEAR AT MINIMUM CONTRAST CONTROL SETTING

Horizontal tear at the top of the picture may be caused by a horizontal damper lead radiating energy into the sync separator circuit.

The effect of this radiation may be reduced by redressing these leads (refer to figure 7, page 5, of Service Bulletin 49T3, PR-1822) as follows:

Redress the blue lead on B3-3 to the mounting jack of the high-voltage condenser, under C46, and under T6 to the condenser mounting jack. This wire connects C51 to C79, and radiates some horizontal output signal to the lead connected from B3-2 to B8-3, which is in the sync separator grid circuit. Also redress this wire (from B3-2 to B8-3) on the 6SN7GT side of B8, under R76 to B8-3.

### ALL MODELS USING 76-5411 SERIES TURRET TUNER Reduction of Modulation Hum

Modulation hum in the reception of high-frequency channels may be reduced by adding an additional 100- $\mu$ f. filament by-pass condenser (Part No. 30-1224-1). This condenser should be wired from the junction of L2-T and L4-T to ground. Physically, the condenser should be connected between the terminal holding the filament feed wire and the adjacent ground knock-out.

With the tuner in the chassis, the parts are made accessible by simply removing about half of the snap-in coils.

## SERVICE HINTS

### MODELS 50-T701; 50-T702, CODE 122

#### Failure of Condenser C81

Failure of condenser C81 in Models 50-T701 and 50-T702 may be caused by operating these receivers when the vertical-output tube is removed. When this tube is removed, there is no voltage drop across resistors R77 and R78. This causes the voltage applied to condenser C81 to exceed the normal value and may result in the failure of this condenser.

#### Dim Picture

A dim picture in Models 50-T701 and 50-T702 may result from leaky d-c blocking condensers to the deflection plates of the picture tube or by faulty high-voltage filter condensers. Whenever a dim picture is encountered, condensers C83, C84, C95, C96, C100 and C101 should be checked for leakage.

### MODEL 50-T1443, CODE 123 TB2 Booster Connections

Early production receivers of the above model did not have the audio-tube socket wired to supply B voltage to 41-3963 booster adaptor. If a booster is required in one of these receivers, pin 6 and pin 4 of the audio-output (6K6GT) tube should be wired together. It may be determined whether this jumper is necessary by taking a voltage reading from pin 6 to ground.

### MODELS 50-T1443, CODE 122; 50-T1443, CODE 123

#### Microphonics Due to Improper Unpacking

The above models may be microphonic if their chassis do not float freely on the chassis shock mounts. When the receiver is placed in operation, the chassis-mounting bolts should be loosened, and all chassis-packing strips should be removed.

### MODEL 50-T1630

#### Dressing the Connecting Line to the Built-In Aerial

Whenever Model 50-T1630 is serviced, the length of transmission line between the built-in aerial and the aerial-input terminal board should be dressed away from the picture tube. This can be accomplished by

taping this line to the line between the aerial-input terminal board and the tuner unit, at a point as near the tuner unit as possible.

### Replacing the Picture-Tube Insulating Cone (Philco Part No. 54-7791)

A replaced picture-tube insulating cone in Model 50-T1630 may be prevented from riding up on the tube bell by taping the leading edge of the cone to the rim of the tube before the insulating ring is installed. Any type of cellophane tape, such as Scotch Tape, is satisfactory for this purpose.

### '50 MODELS HAVING BUILT-IN AERIALS Reducing Harmonic Beat

To reduce harmonic beat in models having a built-in aerial, it is important that the picture-tube mounting-frame assembly be grounded to the chassis. This grounding is accomplished by means of a flat metal strap.

In case this strap is broken, it may be repaired by the use of a clip, Philco Part No. 56-7741, as shown below.

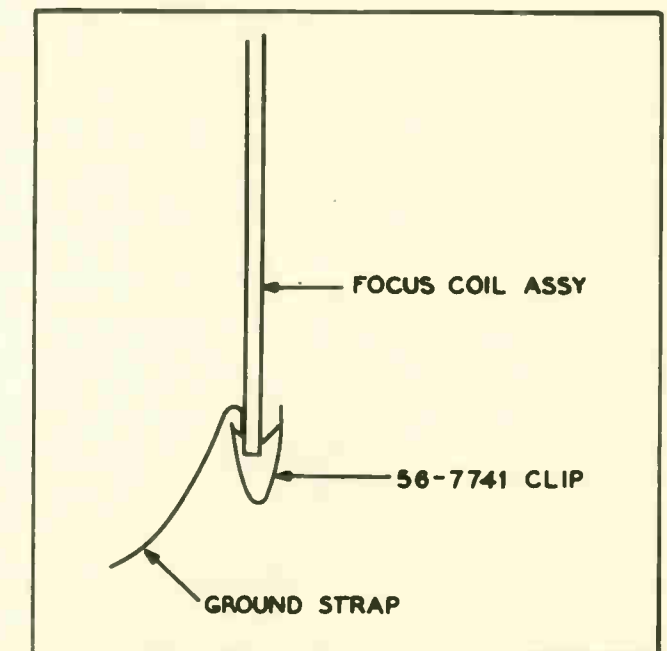

Figure 10. Simple Ground-Strap Repair

When it is necessary to replace the entire strap, the following strap assemblies are available.

Length of Strap	Part No.
3 3/4 inches	76-5472
6 inches	76-5472-1

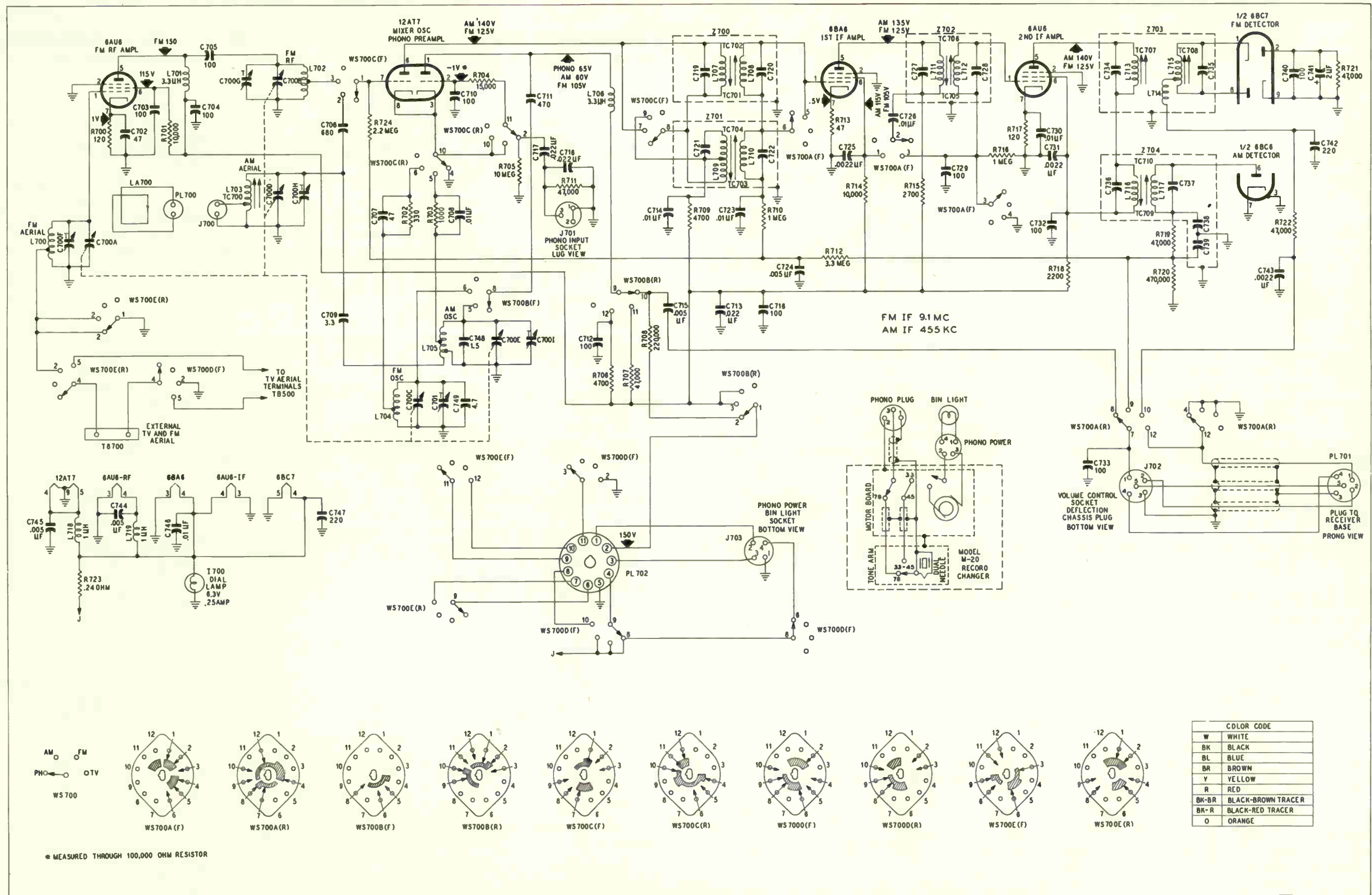

Figure 23. Schematic Diagram, Radio AM-FM Tuner RT-2, Used in Models 51-T1875, 51-T1876, Code 124, 51-T2175, Code 124, and 51-T2176, Code 124

**PREPRODUCTION CHANGES IN MODEL 50-T1104, CODE 123**

The following changes were made in Model 50-T1104,

Code 123, between the time of printing of Service Manual and the time of first production of Model 50-T1104, Code 123:

DESCRIPTION OF CHANGE	REMOVED PART NO.	ADDED PART NO.
470-ohm resistor (R128) added in series with lead between C6 and junction of L55 and C68.		66-1478340
2.2- $\mu$ f. condenser (C116) added between ground and junction of C6 and R128.		30-1221-4
C111 removed.	45-3505-60	
C79 changed from .15 $\mu$ f. to .47 $\mu$ f.	45-3505-48	61-0133
R121 removed. R28 changed from 10,000 ohms to 5000 ohms.	33-1335-47	33-3435-30
R108 changed from 270,000 ohms to 390,000 ohms.	66-4278340	66-4398340
R72 changed from 5100 ohms to 1500 ohms.	33-5546-28	66-2155340
1500- $\mu$ f. condenser (C117) added in parallel with C27.		62-215001011

DESCRIPTION OF CHANGE	REMOVED PART NO.	ADDED PART NO.
R121 removed. R28 changed from 10,000 ohms to 5000 ohms.	33-1335-47	33-3435-30
R94 changed from 6800 ohms to 5100 ohms.	66-2688340	66-2518240
L68 removed; L69 connected across R29.	32-4112-15	
470-ohm resistor, R128, added in series with lead between C6 and junction of L55 and C68.		66-1478340
R116 removed. R115 connected to junction of R114 and C51.	66-4685340	
J8 and S2 removed. Leads to S2 rewired so that connections are same as when S2 was switched to TELEVISION position. R109 removed. Cathode (pin 3) of horizontal-output tube grounded.	27-6126 42-1893-1 66-2105340	
Ungrounded end of C28 disconnected and reconnected to junction of R67 and R68.		
1500- $\mu$ f. condenser (C117) added in parallel with C27.		62-215001011

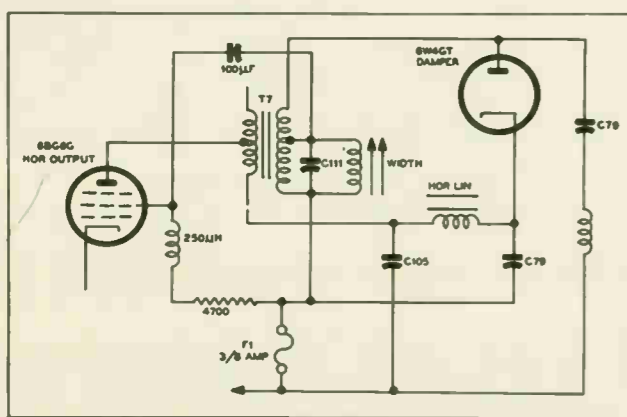

Figure 3. Location of Fuse, Run 3F, and 2F of Models 50-T1400 and 50-T1402

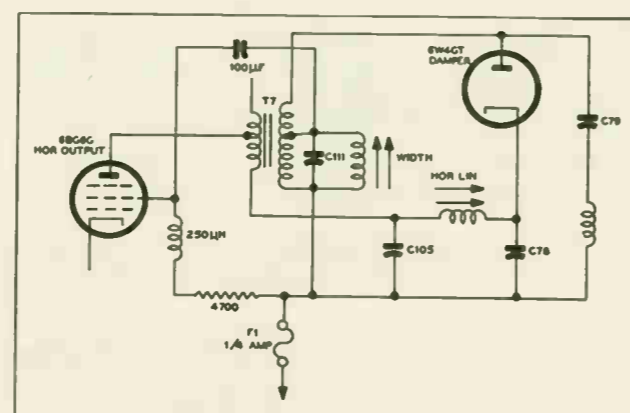
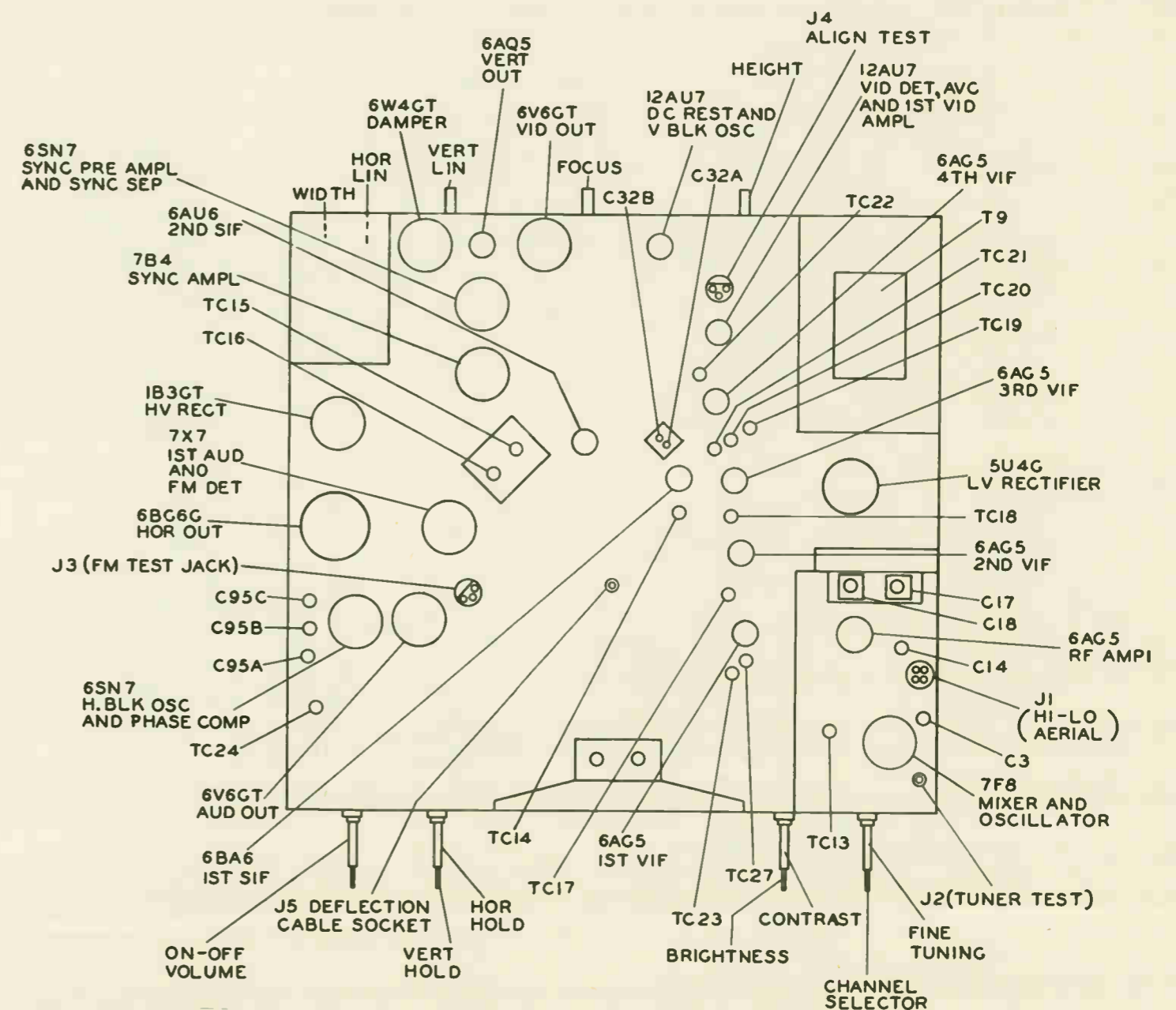

Figure 4. Location of Fuse, Run 4 of Models 50-T1400 and 50-T1402

**PRODUCTION CHANGES IN MODEL 50-T1104, CODE 123**

RUN NO.	DESCRIPTION OF CHANGE	REMOVED PART NO.	ADDED PART NO.	REASON FOR CHANGE
2	J8 and S2 removed. Leads to S2 rewired so that connections are same as when S2 was switched to TELEVISION position. R109 removed. Cathode (pin 3) of horizontal output tube grounded.	27-6126 42-1893-1 66-2105340		
3	.0022- $\mu$ f. condenser, 470-ohm resistor, and 600-microhenry choke connected in parallel, and added in series with lead between pin 4 of T7 and pin 5 of damper tube.		45-3505-54 66-1475340 32-4284-1	To eliminate Barkhausen oscillations.
4	L55 changed to different coil.	32-4234-4	32-4234-8	To improve picture quality.
4	R118 changed from 5100 ohms to 5600 ohms.	66-2518340	66-2568340	To improve picture quality.
4	C68 and C80 changed from 18 $\mu$ f. to 51 $\mu$ f.	60-00185317	30-1224-82	To improve picture quality.





## SERVICE HINTS

### IMPORTANT — DO NOT OPERATE 50-T SERIES WITH DEFLECTION YOKE DISCONNECTED

Operating the 50-T series with the deflection yoke disconnected removes the load from the 6BG6G tube, causing excessive screen current and damage to the screen dropping resistor. A deflection yoke should always be connected when the Receiver is in operation. If a complete picture-tube assembly is not available, a yoke by itself will be satisfactory.

#### TUBE COMPLEMENT

LOKTAL	OCTAL	MINIATURE	CRT
1-7F8	2-5Y3GT/G	5-6AG5	1-10BP4
1-7X7	1-6V6GT	1-6BA6	
2-7N7	1-6BG6G	1-6AU6	
1-7C5	1-6W4GT	1-6AQ5	
1-7B4	1-1B3GT	2-12AU7	

#### GENERAL

##### Failure of Brightness Control to Reduce Brilliance of Picture

A leaky d-c blocking condenser between the video-output stage and the picture-tube grid or between the video-output stage and the d-c restorer will cause an extremely bright picture that is not affected by the setting of the BRIGHTNESS control.

Whenever the BRIGHTNESS control fails to reduce the brilliance of a picture, these condensers should be checked for leakage.

##### Loose Oscillator Tuning Cores

The oscillator tuning cores of all models using the 8-position turret tuner may be secured by the use of a spring, Philco Part No. 56-7270.

Slip this spring over the tuning core and solder one side to the coil form. See figure 6.

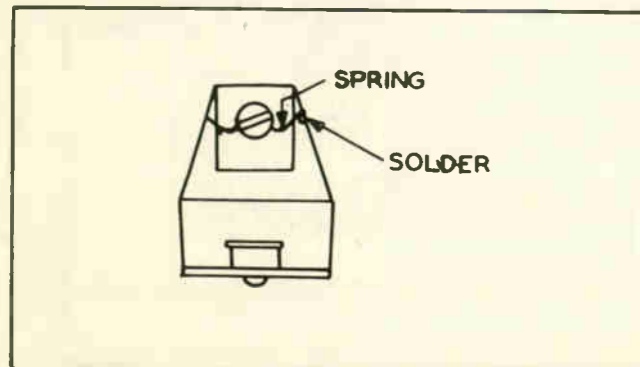

TP9-664

Figure 6. Oscillator Coil for 8-Position Tuner, Showing Spring Installed Over Tuning Core

### MODELS 50-T1104, CODE 123, 50-T1400, 50-T1401, 50-T1402, 50-T1403, 50-T1404, 50-T1406, 50-T1430, AND 50-T1432— PLACEMENT OF 1B3GT ANODE CAP

It is possible to place the anode cap on the 1B3GT tube, in the above Receivers, so that it is too close to the top of the high-voltage cage. When placing the anode cap on the tube, make sure that it is placed as illustrated below.

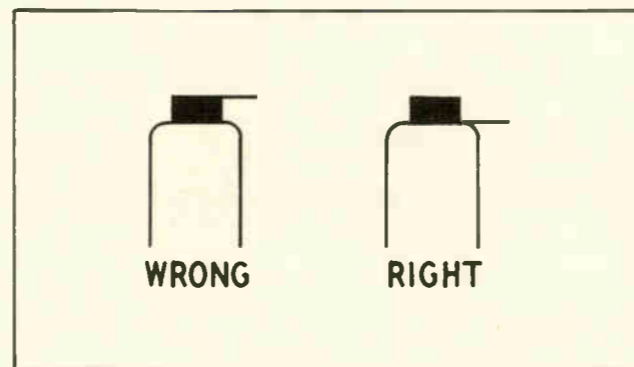

TPO-509

Figure 4. Placement of 1B3GT Anode Cap

### ALL 50-T MODELS—INTERFERENCE (HORIZONTAL STREAKS)

In some cases, horizontal streaks may be caused by video or a-c voltage being fed back into the first v-i-f stage. One cause of this coupling is the leads running to the CONTRAST control, which carry video voltage, being too close to the 28.1-mc. trap. In this case, these wires should be dressed away from the trap, and as close to the chassis as possible. In some extreme cases, it may be necessary to reroute these wires as in later production of Model 50-T1443, Code 123. In this chassis, the wires are routed from the CONTRAST control out through a hole near the control, down the front of the chassis, into a ventilation hole near the bottom-right corner, and thence to the output stage.

In all cases, all leads must be dressed away from the 28.1-mc. trap.

### MODELS 50-T1104; 50-T1105; 50-T1106

#### Connecting Television Booster TB2

In the above models, the cathode and filament circuits of the 6V6GT audio-output tube are 130 volts above ground. Therefore, the octal-power adapter for Television Booster TB2 is not applicable to these models. A special 3-prong socket is incorporated into the top of the chassis, near the speaker, to supply booster power. A Plug and Cable Assembly, Part No. 41-3942, should be used to connect the booster to this socket.

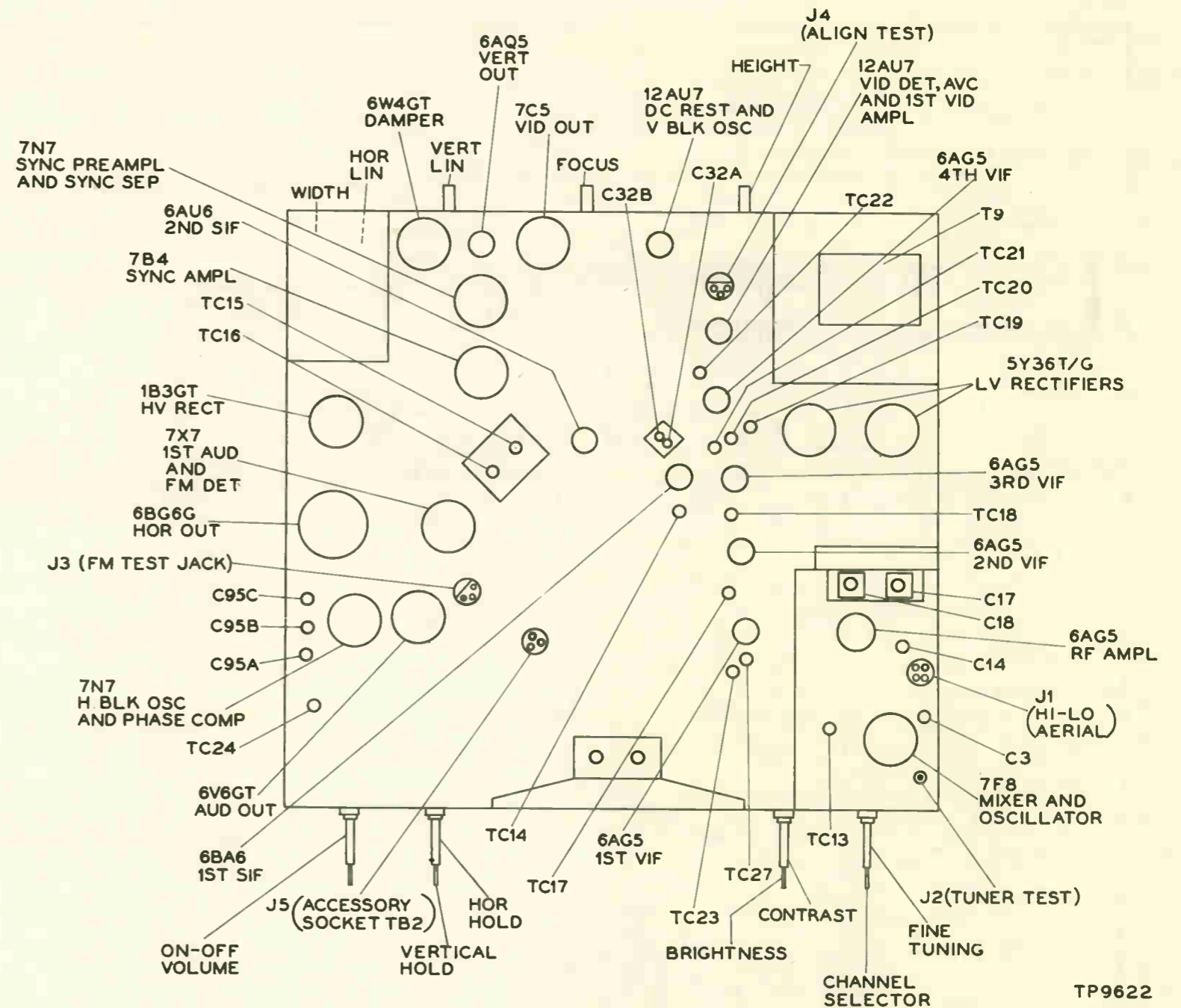

TP9622

#### CIRCUIT DESCRIPTION

The chassis of Philco Models 50-T1105 and 50-T1106 are the same. Each model uses a 10-inch picture tube and a wide mask. Provision is made for the connection of an external record player, and a socket is available for the connection of Philco Television Booster Model TB-2.

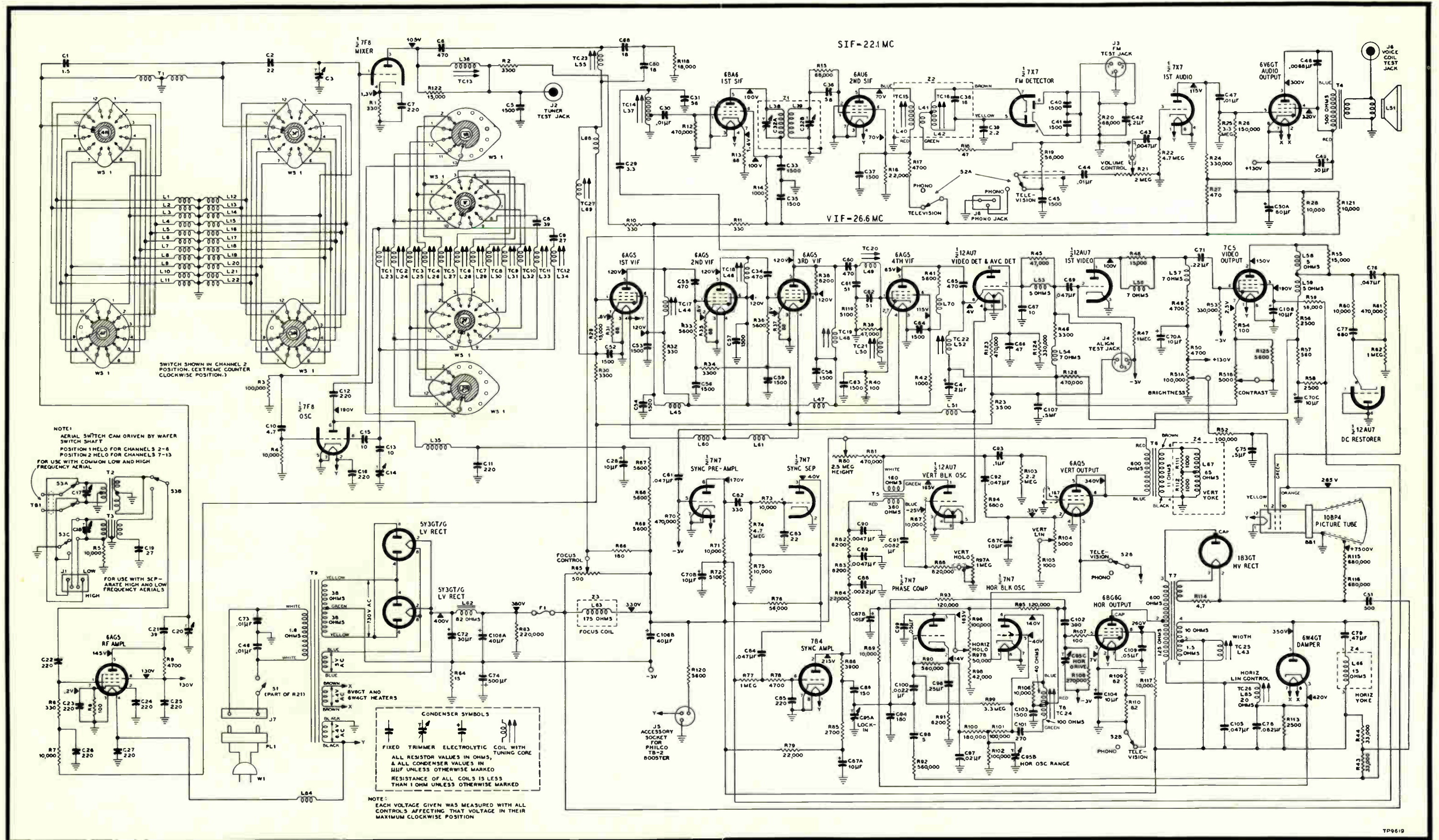

Figure 11. Philco Television Receiver Model: 50-T1105 and 50-T1106, Schematic Diagram

**MODELS 50-T1104, CODE 123, 50-T1400, 50-T1401, 50-T1402, 50-T1403, 50-T1404, 50-T1406, 50-T1430, 50-T1432; 50-T1476 THROUGH 50-T1482; 50-T1484—NEW HORIZONTAL-OUTPUT TRANSFORMER**

The horizontal-output transformer for the above models has been changed. The new part numbers are given below:

Model	New Transformer Part No.
50-T1104 through 50-T1432 50-T1476 through 50-T1482; 50-T1484	32-8437 32-8421-2

The above transformer should be used for all replacements in these models.

**ALL MODELS USING PHILCO 12-POSITION TURRET TUNER (PART NO. 76-5411 SERIES)—CHANGE IN MIXER PLATE COIL**

To reduce the effect of the mixer plate tank on the mixer grid tuning, the mixer plate tank coil was changed to a tapped type, and the circuit was changed. Part No. 45-1695, given in the turret tuner manual (PR-1803), is for this tapped coil. The part number of the untapped coil used in some early tuners is 45-1711. The new circuit is shown in Figure 3.

Because of the effect of the mixer plate load on the mixer grid tuning, these coils are not interchangeable. Before procuring a replacement coil, it should be determined, by observation, which type of coil is used.

**MODELS 50-T1104, CODE 123; 50-T1400 SERIES**

**Horizontal Sync and Drive Padder Identification**

Future production of the above models will not have the horizontal sync and drive padder function stamped adjacent to the padder.

The relative position of the padders will remain the same, and the applicable service manual should be referred to for the specific location.

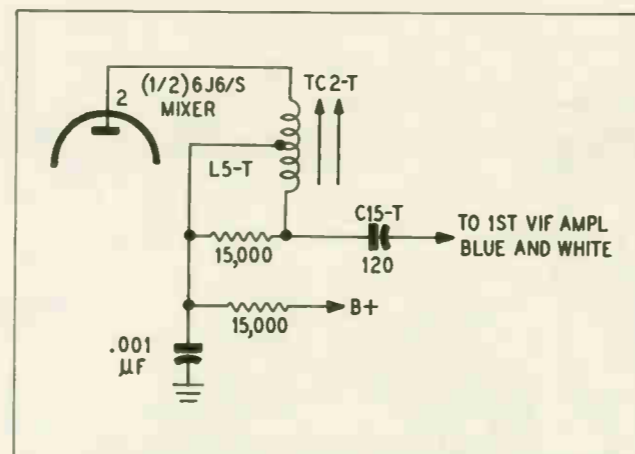

Figure 3. Changes in Mixer Plate Circuit for Models Using 12-Position Turret Tuner

**PRODUCTION CHANGES IN MODELS 50-T1400; 50-T1401; 50-T1402; 50-T1430**

RUN NO.	DESCRIPTION OF CHANGE	REMOVED PART NO.	ADDED PART NO.	REASON FOR CHANGE
6	R94 changed from 5100 ohms to 5600 ohms.	66-2518340	66-2568340	To reduce vertical foldover.
6	R66 changed from 180 ohms to 100 ohms.	66-1184340	66-1104340	To center range of FOCUS control.
7*	L72, C111, and C115 removed. Screen (pin 8) of horizontal-output tube connected through R127 to secondary tap of T7. L43 changed to improved type width coil.	32-4143-7 45-3505-60 60-10105407 32-4419	32-4419-2	To improve horizontal deflection.
7*	R108 changed from 270,000 ohms to 180,000 ohms.	66-4278340	66-4188340	To improve horizontal deflection.

\* Other runs incorporating this change have "Y" stamped after the run number.

**PRODUCTION CHANGES**

Philco Service Bulletins 49T3, 49T4, 49T5, and 50T1 describe production changes in 1950 Television Models.

Changes made after the printing of the bulletins are given below.

**MODELS 50-T1400, 50-T1401, 50-T1402, 50-T1403, 50-T1404, 50-T1406, AND 50-T1430, ALL CODE 121**

RUN NO.	DESCRIPTION OF CHANGE	REMOVED PART NO.	ADDED PART NO.	REASON FOR CHANGE
14	C101, 270 μf., changed to 220 μf.	60-10275407*	60-10225317*	To center range of horiz. osc. coil slug.
15	L43 (width coil) changed.	32-4419-2	32-4419-3	To increase width.
16	1B3 socket and wiring changed. Wiring removed from pin 5 and placed on pin 4.	27-6174-5	27-6174-7	To prevent shorting of components due to internal connections on pins 1, 3, and 5 of some 1B3GT tubes.
17	Extensive changes were made in physical location of sound detector parts.			To reduce harmonic beat.
18	R130 removed. R56, 2500 ohms, changed to 1800 ohms.	66-3108340* *33-1335-87	66-2185340*	
19	Vertical-output transformer (T6) changed to smaller size.	32-8405	32-8425-1 (For replacement purposes, use 32-8405*.)	
20	Fuse added, in series with ground lead of filament winding of power transformer.		Length of #26 copper wire.	To provide protection against filament shorts.
21	820-μf. condenser added, to screen of horizontal output tube (6BG6G).		60-10825001*	To reduce parasitic oscillation in 6BG6G tube.
22	B supply fuse changed to 1/2-amp. delayed-action type, and wired in series with B-lead of power transformer.	45-2656-8	45-2656-17 (1/2 amp. delayed action.)	To provide additional protection.

**MODELS 50-T1400, 50-T1402, 50-T1403, 50-T1404, AND 50-T1406, ALL CODE 122**

RUN NO.	DESCRIPTION OF CHANGE	REMOVED PART NO.	ADDED PART NO.	REASON FOR CHANGE
2	1B3 socket and wiring changed. Wiring removed from pin 5 and placed on pin 4.	27-6174-5	27-6174-7	To prevent shorting of components due to internal connection on pins 1, 3, and 5 of some 1B3GT tubes.
3	R130 removed. R56, 2500 ohms, changed to 1800 ohms.	66-3108340* *33-1335-87	66-2185340*	
4	Vertical-output transformer (T6) changed to smaller size.	32-8405	32-8425-1 (For replacement purposes, use 32-8405*.)	
5	Fuse added, in series with ground lead of filament winding of power transformer.		Length of #26 copper wire.	To provide protection against filament shorts.
6	820-μf. condenser added, to screen of horizontal output tube (6BG6G).		60-10825001*	To reduce parasitic oscillation in 6BG6G tube.

\*The part number given for R56 (2500-ohm plate load resistor) in the Service Manual is incorrect. The correct part number is 33-1335-87.



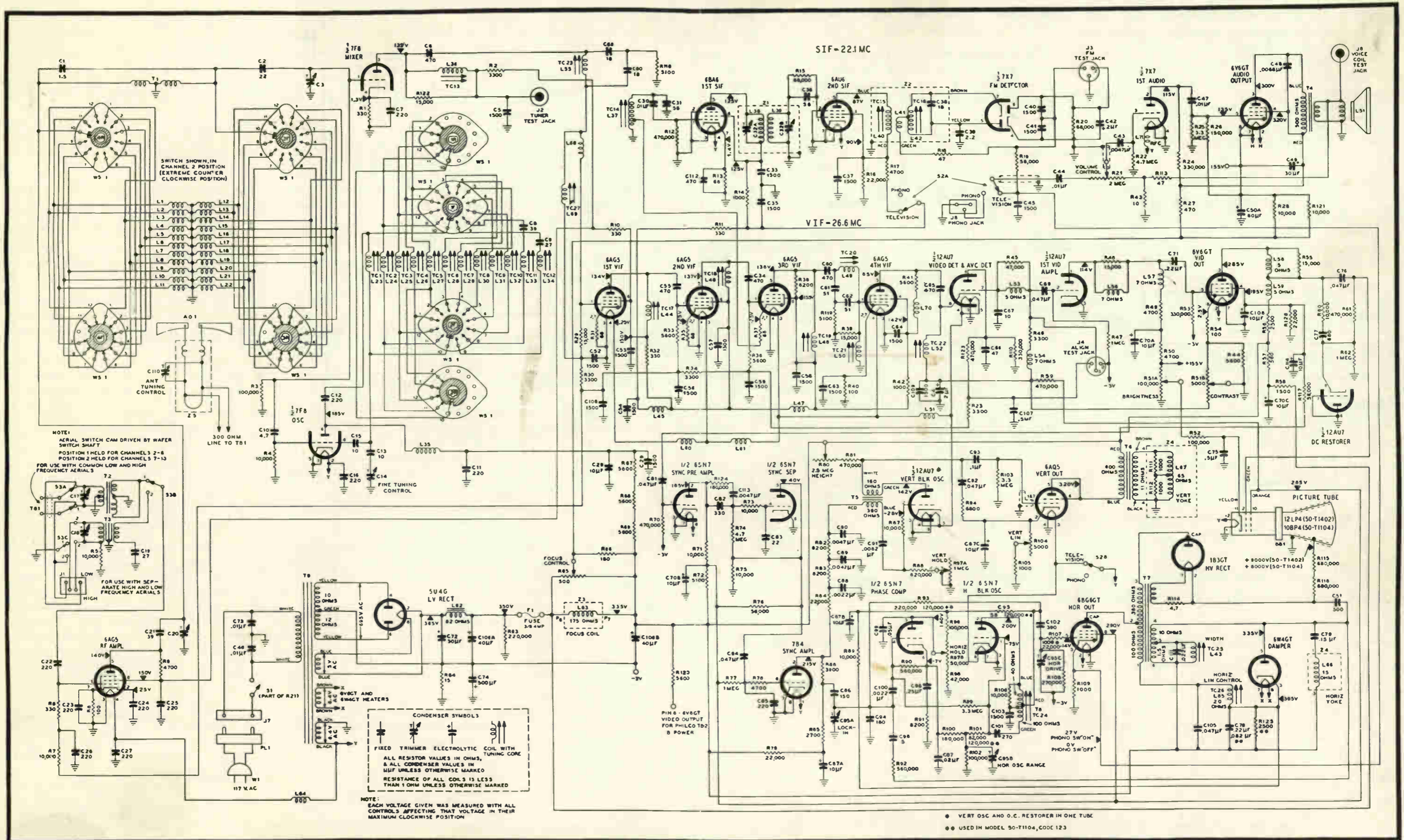

PRODUCTION CHANGES IN MODELS 50-T1400 AND 50-T1402

CORRECTIONS TO SERVICE MANUAL

The caption for figure 10 should read "Philco Television Receiver Models 50-T1400; 50-T1402; 50-T1104, Code 123; Complete Schematic Diagram."

Pins 2 and 7 of the high-voltage rectifier tube should be reversed.

In the schematic diagram, the video-output screen by-pass condenser, C108, should be deleted.

PREPRODUCTION CHANGES IN MODELS 50-T1400 AND 50-T1402

The following changes were made in Models 50-T1400 and 50-T1402 between the time of printing of Service Manual PR-1793 and the time of first production of Models 50-T1400 and 50-T1402:

RUN NO.	DESCRIPTION OF CHANGE	REMOVED PART NO.	ADDED PART NO.	REASON FOR CHANGE
2	2.2- $\mu$ f. condenser added between ground and junction of C6 and R128.		30-1221-4	To center tuning of first video-i-f transformer.
2Z and 3	Arm of HEIGHT control disconnected and rewired to junction of R89 and R96.			To improve vertical linearity.
1F	F1 removed from position shown in service manual and rewired as shown in figure 3. This run does not include the changes made in runs 2, 2Z, or 3.			To provide increased protection.

DESCRIPTION OF CHANGE	REMOVED PART NO.	ADDED PART NO.
L55 changed to different coil.	32-4234-4	32-4234-8
R118 changed from 5100 ohms to 5600 ohms.	66-2518340	66-2568340
C68 and C80 changed from 18 $\mu$ f. to 51 $\mu$ f.	60-00185317	30-1224-62
100- $\mu$ f. condenser (C115) added between screen (pin 8) of horizontal-output tube and secondary tap of T7.		60-10105407
Lead to screen (pin 8) of horizontal-output tube removed. Pin 8 reconnected to pin 6 of T7 through a 250-microhenry choke (L72) and a 4700-ohm resistor (R127) in series.		32-4143-7 66-2475340

RUN NO.	DESCRIPTION OF CHANGE	REMOVED PART NO.	ADDED PART NO.	REASON FOR CHANGE
2F	F1 removed from position shown in service manual, and rewired as shown in figure 3. This run includes the changes made in run 2, but does not include the change made in runs 2Z and 3.			To provide increased protection.
3F	F1 removed from position shown in service manual, and rewired as shown in figure 3. This run includes the changes made in runs 2, 2Z, and 3.			To provide increased protection.
4	F1 rewired as shown in figure 4. Value changed from $\frac{3}{4}$ ampere to $\frac{1}{4}$ ampere.	45-2656-10	45-2856-8	To reduce a-c current through fuse.
5	330-ohm resistor added in series with lead between ungrounded (negative end) of C42 and junction of R20 and pin 2.		66-1338340	To reduce harmonic beat.
5	Lead from junction of R19 and pin 3 of J3 disconnected from junction of C40 and C41. C41 removed. C40 connected across R20.	62-215001011		To reduce harmonic beat.
5	150- $\mu$ f. condenser added between ground and junction of R18 and R19.		60-10155407	To reduce harmonic beat.
5	10,000-ohm resistor added across R56 and R57.		66-3104340	To improve video response.
5	R49 changed from 4700 ohms to 3900 ohms.	66-2478340	66-2398340	To improve video response.
5	R54 changed from 100 ohms to 10 ohms.	66-1108340	66-0108340	To improve video response.
5	R44 changed from 5600 ohms to 2200 ohms.	66-2568340	66-2228340	To improve video response.
5	L53 changed from 150 microhenries to 40 microhenries.	32-4143	32-4143-1	To improve video response.
5	R46 changed from 3300 ohms to 2400 ohms.	66-2338340	66-2258340*	To improve video response.
5	R58 changed from 1500 ohms to 1000 ohms.	66-2158340	66-2108340	To improve video response.

RUN NO.	DESCRIPTION OF CHANGE	REMOVED PART NO.	ADDED PART NO.	REASON FOR CHANGE
X	"X" after run numbers 1 through 7 indicates that a short wire jumper is connected across R67.			To improve performance with low line voltage.
8	R67 removed. R68 connected to junction 66-2564340 of L35 and C11.			To improve performance with low line voltage.

MODELS 50-T1400, 50-T1401, 50-T1402, 50-T1430 (Cont.)

RUN NO.	DESCRIPTION OF CHANGE	REMOVED PART NO.	ADDED PART NO.	REASON FOR CHANGE
7A or 9	Tuner No. 76-4402-6 replaced with Tapered-Line Tuner No. 76-5433. R29 changed from 15,000 ohms to 10,000 ohms. R68 changed from 5600 ohms to 1000 ohms. R69 changed from 5600 ohms to 6200 ohms.	76-4402-6 66-3158340  (2) 66-2568340	76-5433 66-3108340 66-2108340 33-1335-19	To incorporate new tuner.
10	C91 changed from .0082 $\mu$ f. to .015 $\mu$ f. R87 removed. Pin 2 of vertical-blocking-oscillator tube connected to junction of C91 and R88. R88 changed from 820,000 ohms to 470,000 ohms. R94 changed from 5100 ohms to 6800 ohms.	61-0174 66-3108340 66-4828340 66-2518340	30-4651-8 66-4478340 66-2688340	To reduce vertical fold-over.

PRODUCTION CHANGE IN I-F STRIP OF MODELS 50-T1400; 50-T1402; 50-T1104, CODE 123

RUN NO.	DESCRIPTION OF CHANGE	REMOVED PART NO.	REASON FOR CHANGE
4	L70 removed. R41 connected between plate (pin 5) and screen (pin 6) of 4th v-i-f tube.	32-4143-1	To improve lead dress.

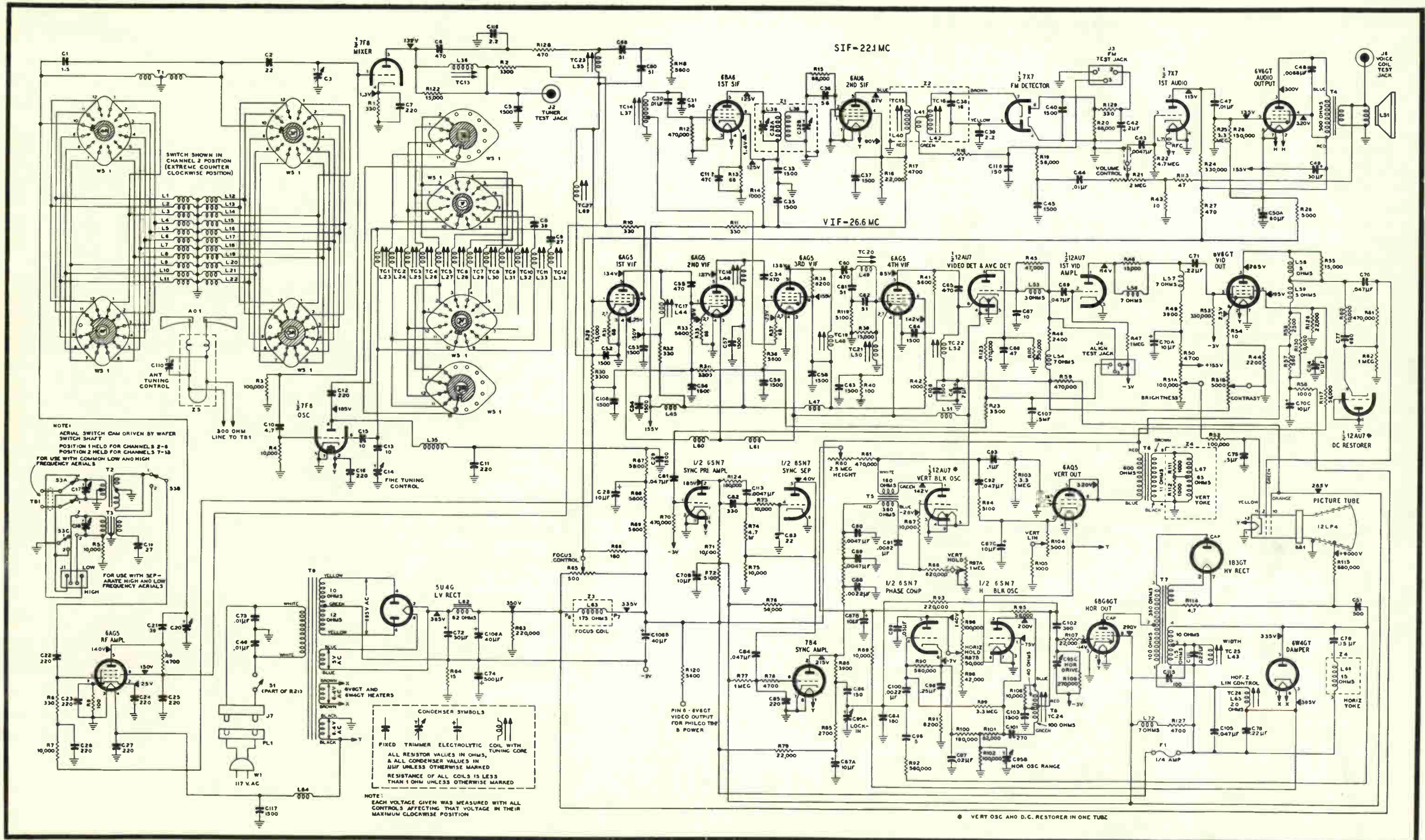

Figure 9. Philco Television Receiver Models 50-T1400, 50-T1401, 50-T1402, and 50-T1430 (All Run 5), Complete Schematic Diagram

# PREPRODUCTION AND PRODUCTION CHANGES IN MODELS 50-T1403, 50-T1404, AND 50-T1406, ALL CODE 125

## MODEL 50-T1403

The chassis used in the above models is similar to the chassis used in Models 50-T1404 and 50-T1406, Code 123. The differences are as follows:

1. A 7N7 tube is used in place of a 6SN7GT in the vertical-sweep-output stage.
2. A 7N7 tube is used in place of a 6SN7GT as a phase comparer and horizontal oscillator.
3. The 7N7 phase comparer and horizontal-oscillator tube is shock-mounted.
4. The phase comparer and horizontal-oscillator circuits are changed, as shown in figure 3.
5. The 47,000-ohm loading resistor (R116) across the video detector series peaking coil (L15) is removed.
6. The series peaking coil (L17) in the plate circuit of the 1st video amplifier is removed, and the plate is connected directly to the shunt peaking coil (L18).
7. The 1-megohm resistor (R85) shunting the VERT. HOLD control is changed to 1.5 megohms.
8. The B supply for Philco Television Booster Model TB-2, on pin 6 of the video-output tube, is obtained directly from the 135-volt bus.

## PREPRODUCTION CHANGES

The following changes were made between the printing of PR-1846 and first production.

1. Resistor R118 was changed to 390,000 ohms, Part No. 66-4394240\*.
2. Condenser C83 was changed to .001  $\mu\text{f.}$ , Part No. 45-3505-52.
3. The blocking condenser (C71) in the horizontal-output circuit was rewired as shown in figure 1.

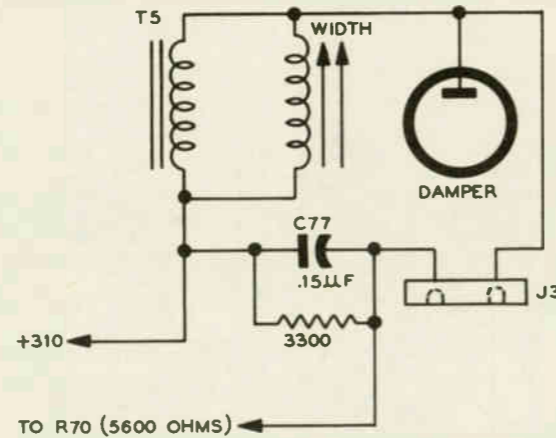

Figure 1. Change in Horizontal-Output Circuit, Models 50-T1403, 50-T1404, and 50-T1406, All Code 125

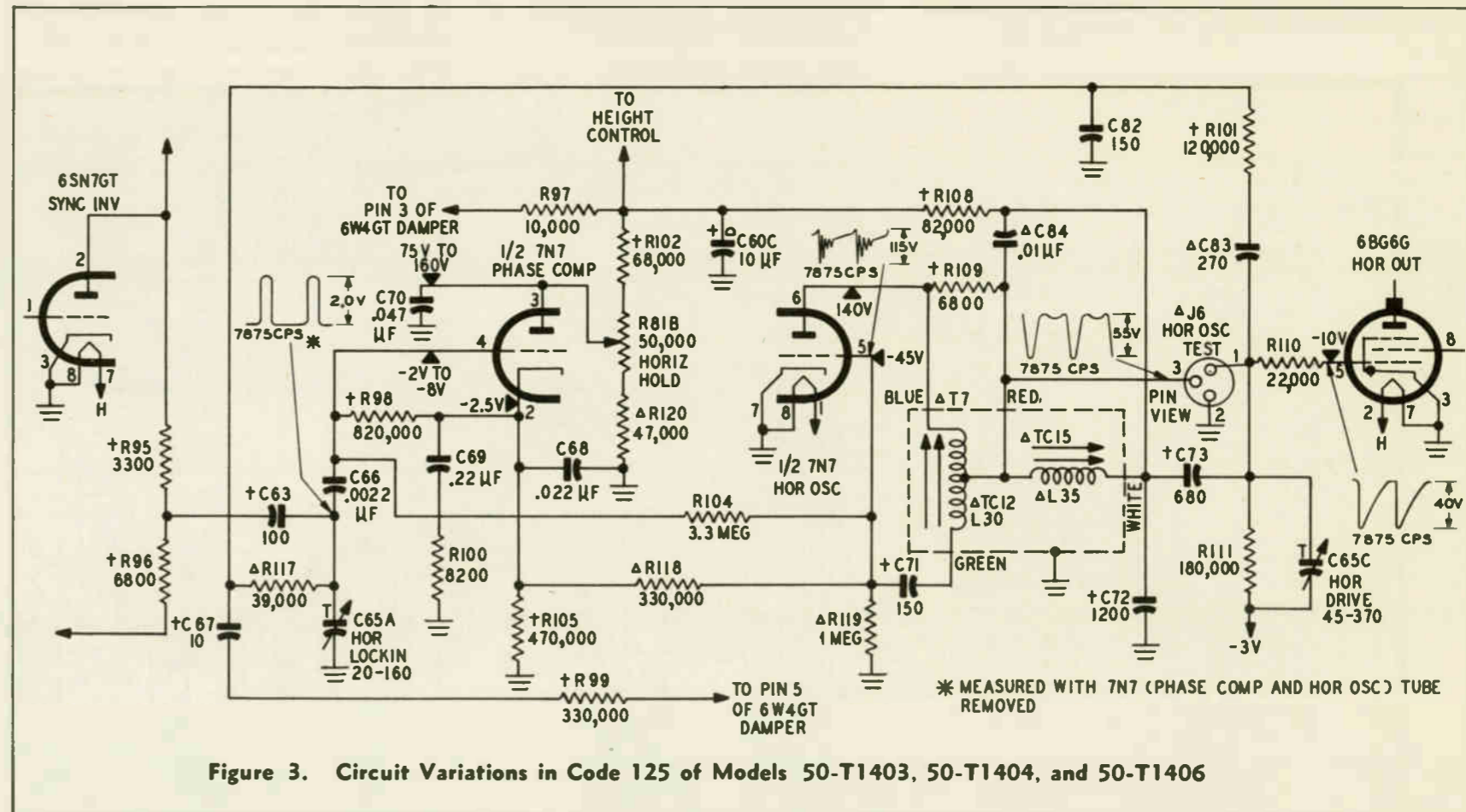

Figure 3. Circuit Variations in Code 125 of Models 50-T1403, 50-T1404, and 50-T1406

## PRODUCTION CHANGES

RUN NO.	DESCRIPTION OF CHANGE	REMOVED PART NO.	NEW OR ADDED PART NO.	REASON FOR CHANGE
2	R108 changed to 56,000 ohms. C73 changed to 390 $\mu\text{f.}$	66-3824240 60-10685401	66-3564240 30-1220-35	To increase width and reduce interaction between width and linearity controls.
3	C67 increased in voltage rating.	60-00105407	30-1224	To reduce possibility of breakdown.
4	Video amplifier, sync take-off point, and sync separator changed as shown in figure 2.	Refer to following Parts List.	Refer to following Parts List.	To improve sync performance, and to improve picture quality with weak signal input.
4Z	A 33- $\mu\text{f.}$ condenser was added, across R32, and L19 was shorted out.		62-033009001	An inductive resistor was used for R32 (see note below.)
5 and 4X	R32 changed to 2000 ohms, non-inductive. The 33- $\mu\text{f.}$ condenser and the short across L19 were removed.	62-03330001		Circuit changed to use non-inductive resistor.
6	C74 changed to .0047 $\mu\text{f.}$	60-01825401	45-3505-90	To reduce parasitic oscillations in the 6B66G.
7	A 680,000-ohm resistor was added, in series with R113.		66-4684340*	To increase width, and reduce squeeze on right side.

## MODELS 50-T1400, 50-T1401, 50-T1402, 50-T1403, 50-T1404, 50-T1406, AND 50-T1430, ALL CODE 121

RUN NO.	DESCRIPTION OF CHANGE	REMOVED PART NO.	ADDED PART NO.	REASON FOR CHANGE
W	"W" stamped after run number indicates that R101 is changed from 82,000 ohms to 68,000 ohms.	66-3828340	66-3688340	To extend range of horizontal-oscillator tank circuit.
V	"V" stamped after run number indicates that R101 is 82,000 ohms, and that an 860,000-ohm resistor is added, across it.		66-4828340	To extend range of horizontal-oscillator tank circuit.
11	Tuner unit shock-mounted.			To reduce microphonics.
11	R69 changed from 6200 ohms to 5100 ohms.	33-1335-19	33-1335-18	To increase tuner B+ voltage.
12	C83 changed from 22 $\mu\text{f.}$ to 12 $\mu\text{f.}$	62-022009001	30-1223-2	To improve interlace and reduce jitters.
13	T9 changed to transformer with hum shield.	32-8411-1	32-8423-2	To reduce picture weave.

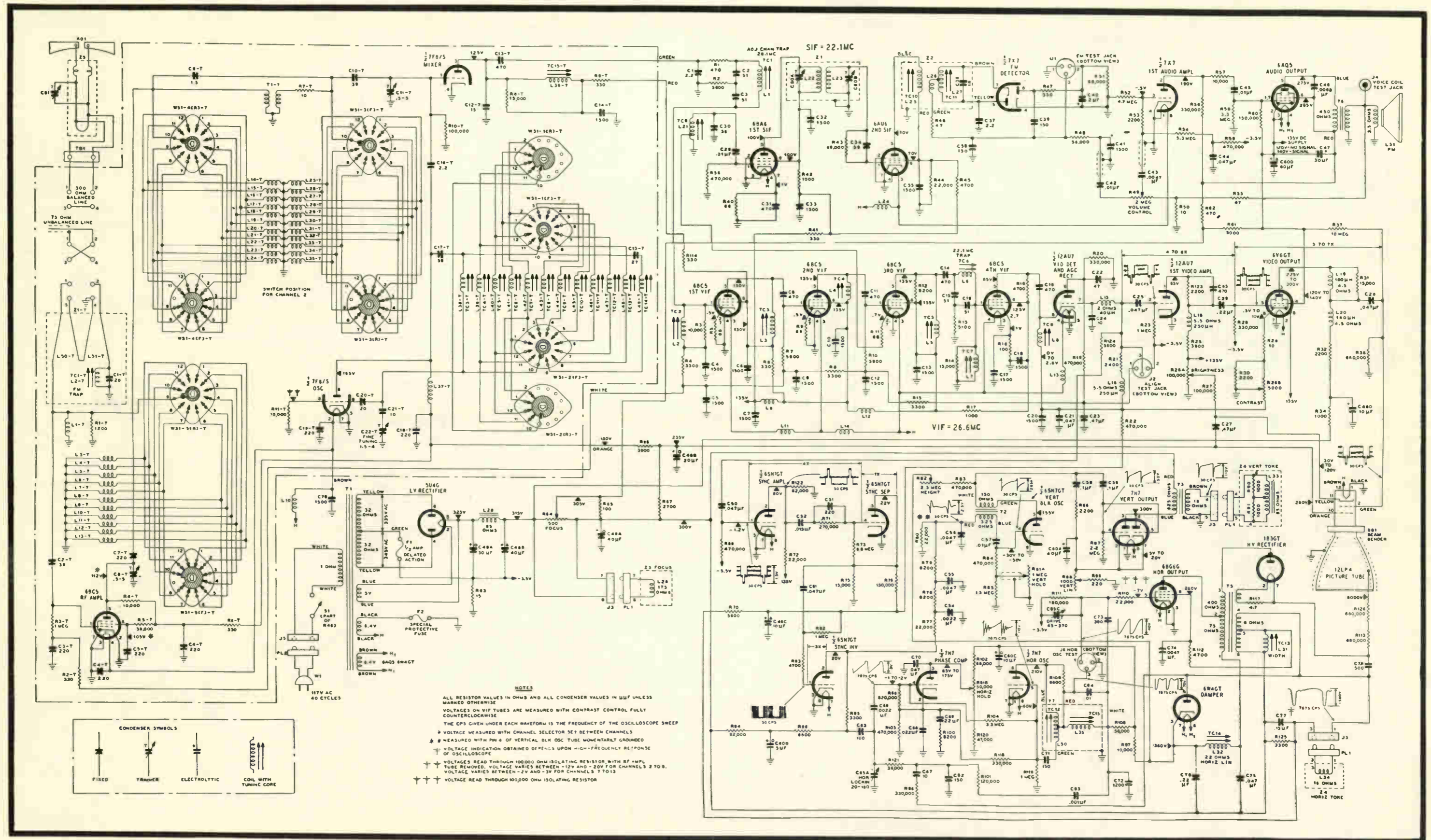

Figure 2. Schematic Diagram, Models 50-T1403, 50-T1404, and 50-T1406, All Code 125 Run 7

## CIRCUIT DESCRIPTION

The same chassis is used in Model 50-T1404, Code 123, and 50-T1406, Code 123, the difference being in cabinet styles. The chassis used in Models 50-T1404, 50-T1406, and 50-T1432, all Code 124, is similar to the Code 123 chassis, with the following exceptions:

1. Code 124 uses a 12-position turret tuner in place of the tapered line tuner.

2. Code 124 uses a 6T8 tube in place of a 7X7 for the FM detector and first audio amplifier.

All models have a built-in aerial, and use a 12-inch picture tube with a wide mask.

The radio-frequency section is built on a subchassis, and incorporates a 6BC5 as an r-f amplifier, and a 7F8/S (Code 123) or 6J6/S (Code 124) as an oscillator-mixer.

## PRODUCTION CHANGES IN MODELS 50-T1404, CODE 123, AND 50-T1406, CODE 123

RUN NO.	DESCRIPTION OF CHANGE	REMOVED PART NO.	NEW OR ADDED PART NO.	REASON FOR CHANGE
2	R85 changed to 1.5 megohms.	66-5108340	66-5158340	To center range of VERT. HOLD control.
3	R68 removed. Pin 6 of video output tube was connected directly to the 135-volt source.	66-2565340		To simplify wiring.
4	L17 and R24 removed. Plate of 1st video amplifier was connected directly to L18.	32-4143-14 66-3158340		To improve video response.

## PHILCO TELEVISION RECEIVER MODELS 50-T1402, 50-T1406, 50-T1432, ALL CODE 122

The chassis of the above models are similar to that used in Model 50-T1400, Code 121, Run 13, except that these models use Philco 12-position turret tuner, Part No. 76-5411-3, and have minor circuit changes, as follows:

- The B+ line from the tuner is connected through a 10,000-ohm resistor, Part No. 66-3104340, instead of through R67, R68, and R69.
- C28 is connected between ground and the junction of the tuner B+ lead and the added 10,000-ohm resistor.
- An r-f choke, Part No. 32-4112-11, is added, in series with the filament lead to the tuner.
- A 1500- $\mu$ f. condenser, Part No. 62-215001011, is connected between ground and the junction of the tuner filament lead and the added r-f choke.

Model 50-T1402, Code 122, and 50-T1406, Code 122, are table models. Model 50-T1432, Code 122, is a console model. Model 50-T1432, Code 122, uses a 10-inch speaker, Part No. 36-1610-6, which is mounted in the cabinet.

Models 50-T1402, Code 122, and 50-T1432, Code 122, have modern-style mahogany-finish cabinets. Model 50-T1406, Code 122, has a Georgian-style cabinet with mahogany finish.

For service information pertaining to the above models, refer to Philco Service Manual PR-1793, which covers Models 50-T1400, 50-T1402, and 50-T1104, Code 123. For service information pertaining to the tuner, refer to Service Manual PR-1803. A list of replacement parts covering the miscellaneous items used in these models is given below.

### MODEL 50-T1432, CODE 122

RUN NO.	DESCRIPTION OF CHANGE
6	Fuse added, in series with ground lead of filament winding of power transformer.

ADDED PART NO.	REASON FOR CHANGE
Length of $\pm 26$ copper wire.	To provide protection against filament shorts.

## PRODUCTION CHANGES IN MODELS 50-T1404, 50-T1406, 50-T1432, ALL CODE 124

RUN NO.	DESCRIPTION OF CHANGE	REMOVED PART NO.	NEW OR ADDED PART NO.	REASON FOR CHANGE
2	R85 changed to 1.5 megohms.	66-5108340	66-5158340	To center range of VERT. HOLD control.
3	R68 removed. Pin 6 of video output tube was connected directly to the 135-volt source.	66-2565340		To simplify wiring.
4	L17 and R24 removed. Plate of 1st video amplifier was connected directly to L18.	32-4143-14 66-3158340		To improve video response.
4	A 3.3- $\mu$ f. condenser was added, from pin 1 of FM detector, 6T8, to ground.		30-1224-30	To improve FM detector AM rejection.

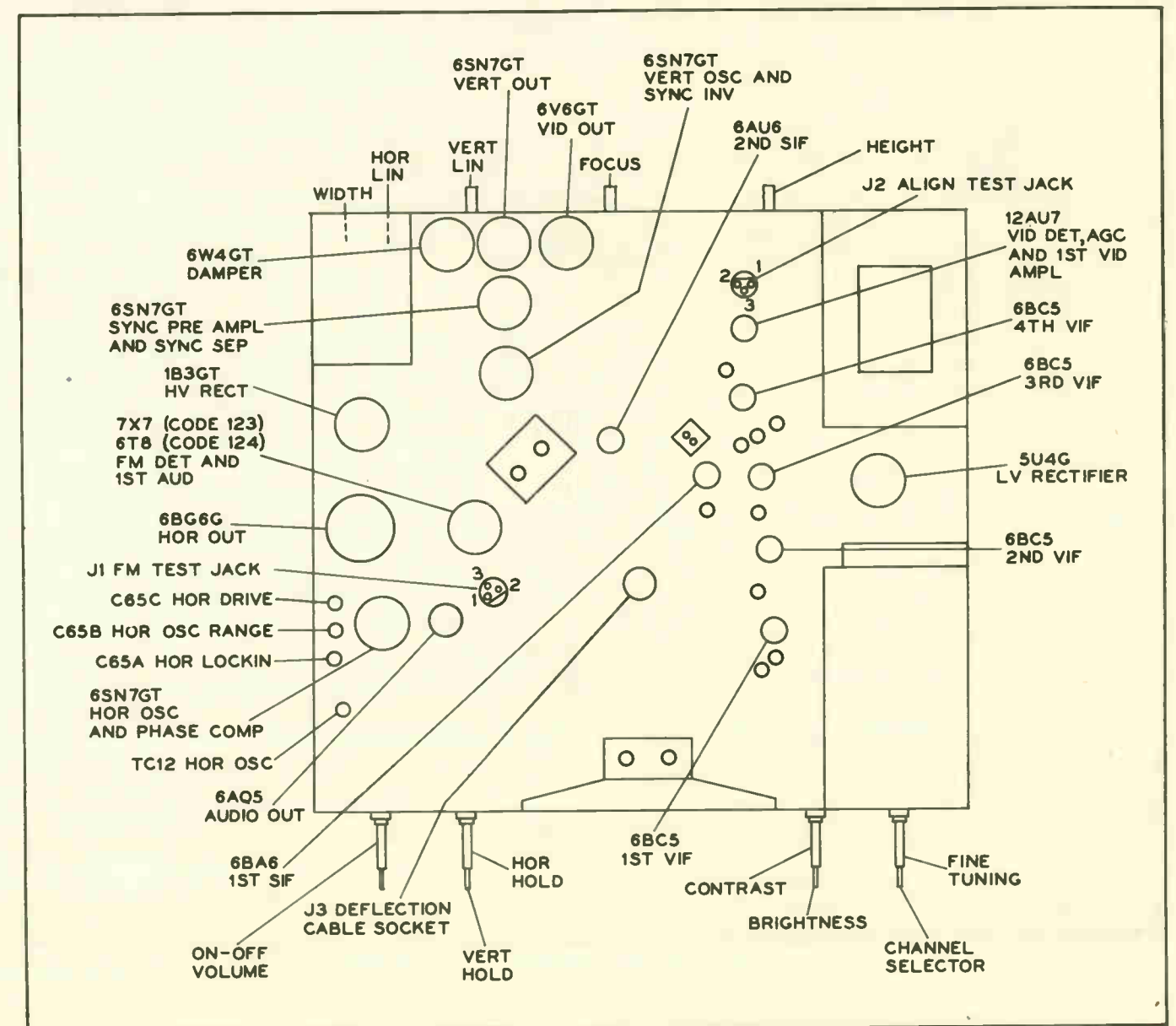



**PREPRODUCTION AND PRODUCTION CHANGES IN PHILCO MODELS  
50-T1443, CODE 122; 50-T1443, CODE 123**

**CORRECTIONS TO SERVICE MANUAL**

The power socket should be J7 instead of J1.  
The reference symbols for C32 and C35 should be reversed.

In the Replacement Parts List, the description for C85 should read "Condenser, electrolytic, 4-section." The Service Part No. should be 30-2570-10.

In the schematic diagram, the following changes should be made:

- a. R61 should be connected across C41 instead of between pins 5 and 7 of the FM detector.
- b. The reference symbol for the CONTRAST control should be R136 instead of R134.

**PREPRODUCTION CHANGE IN MODEL 50-T1443, CODE 123**

Between the time of the printing of Service Manual PR-1800 and the time of first production of Model 50-T1443, Code 123, L71 was removed and reconnected in series with the lead between C15T and the junction of C21 and L45. The junction of C22 and L45 was then connected directly to pin 1 of the first video-i-f amplifier.

**PRODUCTION CHANGES IN MODEL 50-T1443,**

RUN NO.	DESCRIPTION OF CHANGE	REMOVED PART NO.	ADDED PART NO.	REASON FOR CHANGE
5	6800-ohm resistor added between ground and junction of R136 and R36.		66-2688340	To improve picture quality.
5	R36 changed from 47 ohms to 10 ohms.	66-0478340	66-0103340.	To improve picture quality.
5	82,000-ohm resistor added between screen (pin 3) of video-output tube and ground.		66-3824340	To improve picture quality.
5	15,000-ohm resistor added across R40 and R41.		66-3154340	To improve picture quality.
5	C69 changed from .0033 $\mu$ f. to 680 $\mu$ f.	45-3505-55	60-10685401	To improve picture quality.
6	R-f choke added in series with lead between R60 and junction of R47 and C32.		32-4061-2	To reduce beat interference.
6	R32 removed. L53 removed and replaced with 10-microhenry choke. L53 connected in series with lead to ungrounded end of R29, between R29 and junction of L69 and pin 3 of J4. 100- $\mu$ f. condenser added between pin 2 of J4 and ground. These changes were incorporated by replacing the entire i-f strip with another strip.	66-3478340	62-110009001 32-4143-10	To reduce beat interference.
6	470- $\mu$ f. condenser added between ground and junction of R136 and R130.		62-147001001	To reduce beat interference.

**PRODUCTION CHANGE IN MODEL 50-T1443, CODE 122**

RUN NO.	DESCRIPTION OF CHANGE	REASON FOR CHANGE
1Z	In early production of run 1Z, the unused (triangle) section of C80 and the unused (half-moon) section of C85 were added in parallel across R51. In later production of run 1Z, the unused (triangle) section of C80 and the unused (square) section of C70 were added in parallel across R51.	To reduce vertical-sweep-generator feedback into B+ supply.

**PRODUCTION CHANGES IN MODEL 50-T1443, CODE 123**

RUN NO.	DESCRIPTION OF CHANGE	REASON FOR CHANGE
2	Pin 8 of audio-output tube disconnected from 180-volt B+ supply and reconnected to pin 4 of audio-output tube.	To supply higher B+ voltage for Philco Booster TB-2.
1Z 2Z 3	Two unused (triangle and plain) sections of C80 were connected in parallel across R51. Runs 2Z and 3 also incorporate the change made in run 2. Run 1Z does not incorporate the change made in run 2.	To reduce vertical-sweep-generator feedback into B+ supply.
4	C92B disconnected and replaced with unused (half-moon) section of C85.	To provide condenser with higher voltage rating in HEIGHT-control circuit.

**PRODUCTION CHANGES IN I-F STRIP FOR MODELS  
50-T1443, CODE 122; 50-T1443, CODE 123**

RUN NO.	DESCRIPTION OF CHANGE	REMOVED PART NO.	ADDED PART NO.	REASON FOR CHANGE
2	2200-ohm resistor (R135*) added in series with lead between junction of C41 and pin 2 of J3 and junction of C42 and pin 7 of FM-detector tube.		66-2228340	To reduce harmonic beat.
2Z 3	R135* changed from 2200 ohms to 330 ohms.	66-2228340	66-1338340	To facilitate sound-i-f alignment.

**MODEL 50-T1443, CODE 123**

RUN NO.	DESCRIPTION OF CHANGE	REMOVED PART NO.	ADDED PART NO.	REASON FOR CHANGE
6Z and 7	R114 changed from 100,000 ohms to 82,000 ohms.	66-4108340	66-3828340	To center HORIZ. HOLD control.

**PRODUCTION CHANGES IN MODEL 50-T1443, CODE 123**

RUN NO.	DESCRIPTION OF CHANGE	REMOVED PART NO.	ADDED PART NO.	REASON FOR CHANGE
5	180-microhenry peaking coil added in series with lead between R40 and junction of L56 and R44.		32-4143-5	To improve picture quality.



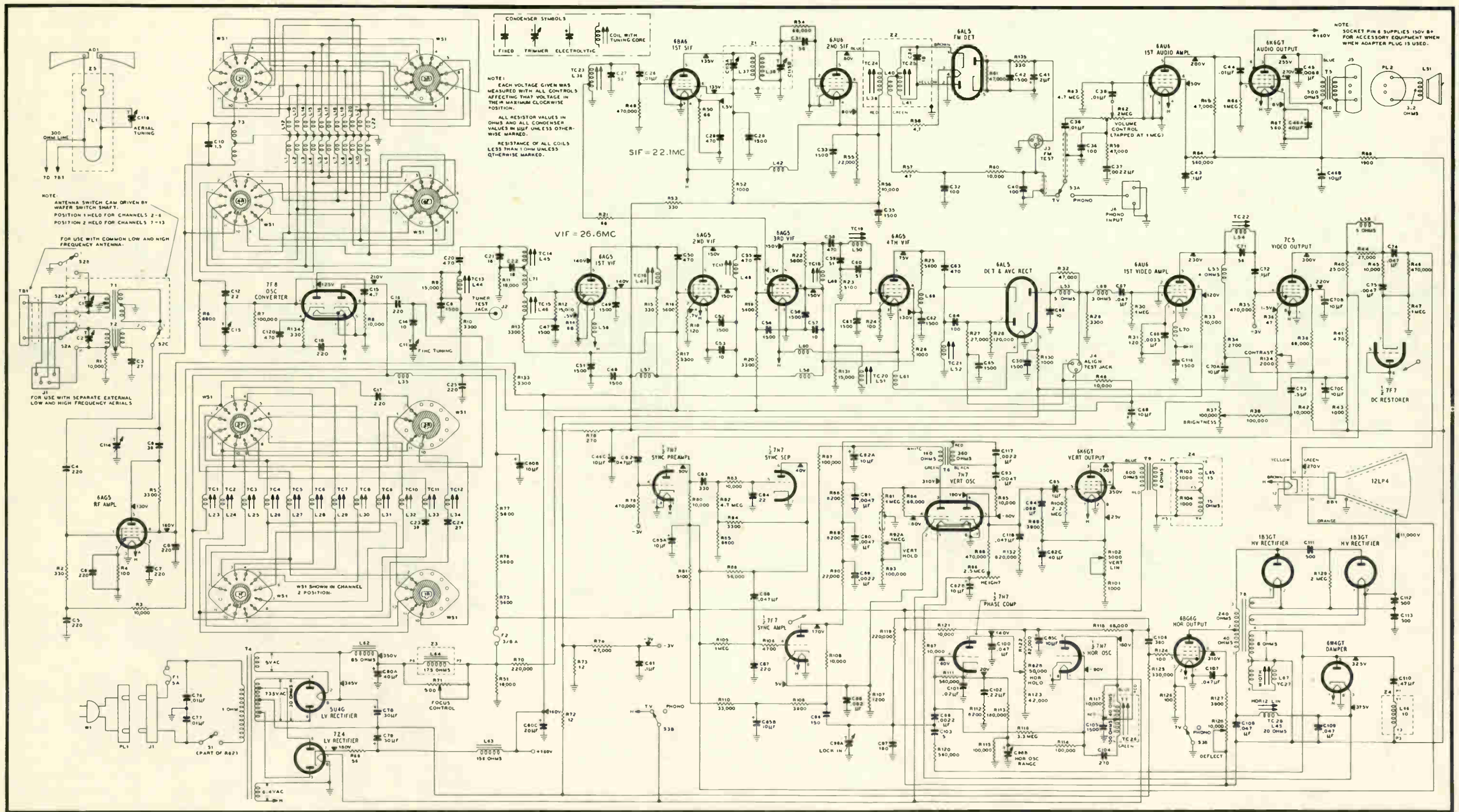

Figure 10. Philco Television Receiver Model 50-T1443, Code 122, Complete Schematic Diagram

**MODELS 50-T1476, 50-T1477, 50-T1478, 50-T1479, 50-T1481, 50-T1482, AND 50-T1484**

RUN NO.	DESCRIPTION OF CHANGE	REMOVED PART NO.	ADDED PART NO.	REASON FOR CHANGE
1Z and 2	R118 changed from 120,000 ohms to 100,000 ohms.	66-4128340	66-4108340	To center HORIZ. HOLD control.
3	C88 removed. R123 changed from 10,000 ohms to 4700 ohms. R119 changed from 120,000 ohms to 56,000 ohms. R121 changed from 100 ohms to 10,000 ohms. L43 changed. .022- $\mu$ f. condenser added, across L43.	45-3505-62 66-3105340 66-4124340 66-1108340 32-4419	66-2475340 66-3564340 66-3568340 32-4419-2 45-3505-60	To increase width.
3Y and 4	R118 changed from 100,000 ohms to 82,000 ohms.	66-4108340	66-3828340	To center HORIZ. HOLD control.

RUN NO.	DESCRIPTION OF CHANGE	REMOVED PART NO.	ADDED PART NO.	REASON FOR CHANGE
5	L43 (width coil) changed.	32-4419-2	32-4419-3	To increase width.
6	1B3 socket and wiring changed. Wiring removed from pin 5 and placed on pin 4.	27-6174-5	27-6174-7	To prevent shorting of components due to internal connections on pins 1, 3, and 5 of some 1B3GT tubes.
7	Fuse added in series with ground lead of filament winding of power transformer.		Length of #26 copper wire.	To provide protection against filament shorts.
8	Vertical-output transformer changed to smaller size.	32-8405-1	32-8425 (For replacement purposes, use 32-8405*.)	

**MODEL 50-T1483**

RUN NO.	DESCRIPTION OF CHANGE	REMOVED PART NO.	ADDED PART NO.	REASON FOR CHANGE
1Z and 2	R136 changed from 100,000 ohms to 82,000 ohms.	66-4108340	66-3828340	To center HORIZ. HOLD control.
3	C131 removed. 470- $\mu$ f. condenser added, between ground and junction of L57, L18, and L22. 100- $\mu$ f. condenser added, across C96. 6800-ohm resistor added, in series with lead between R71 and R77B.	62-215001011	62-147001001 62-110009001 66-2688340	To reduce beat interference.

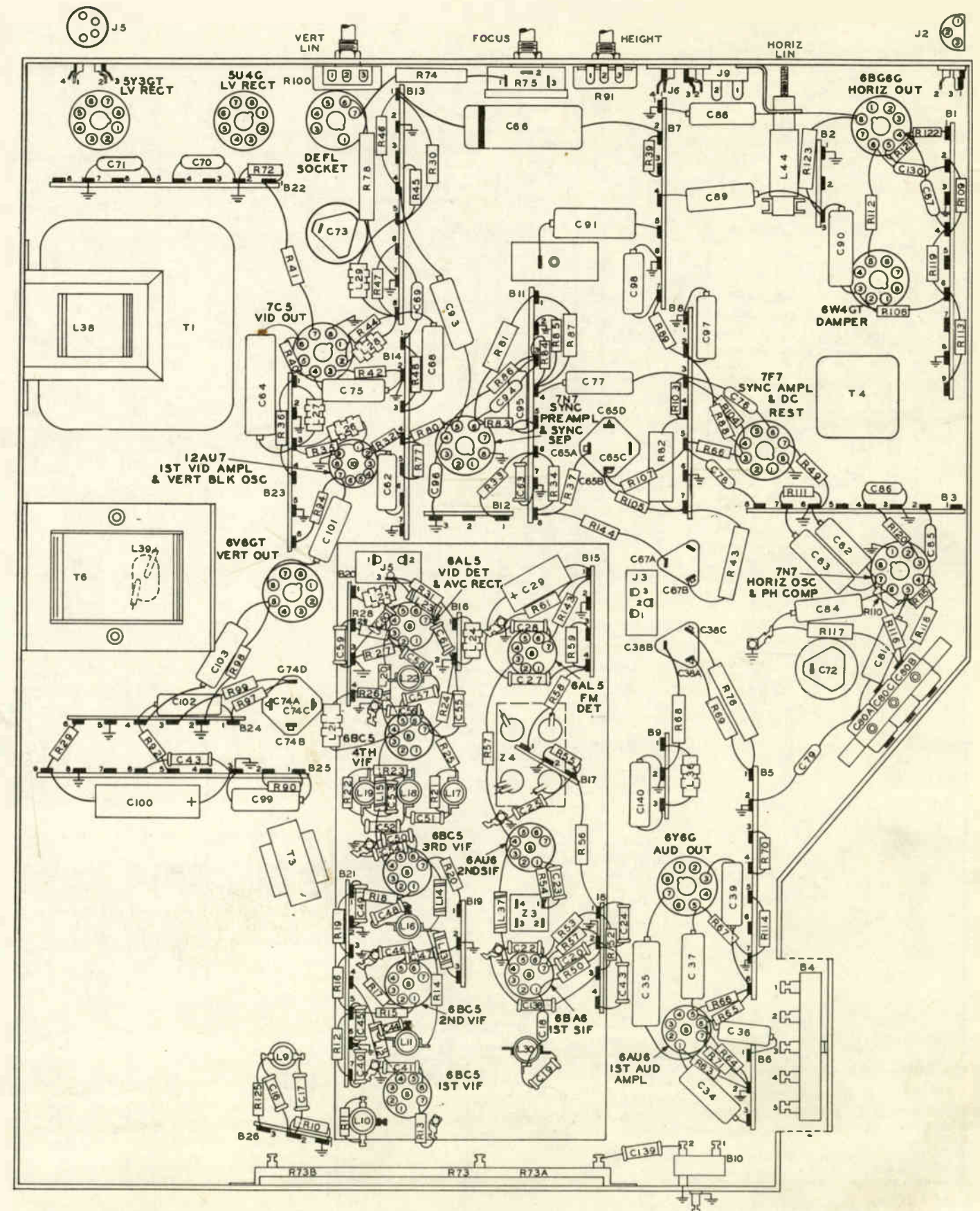

Figure 4. Bottom View of Chassis (TV), Models 50-T1477 to 50-T1482

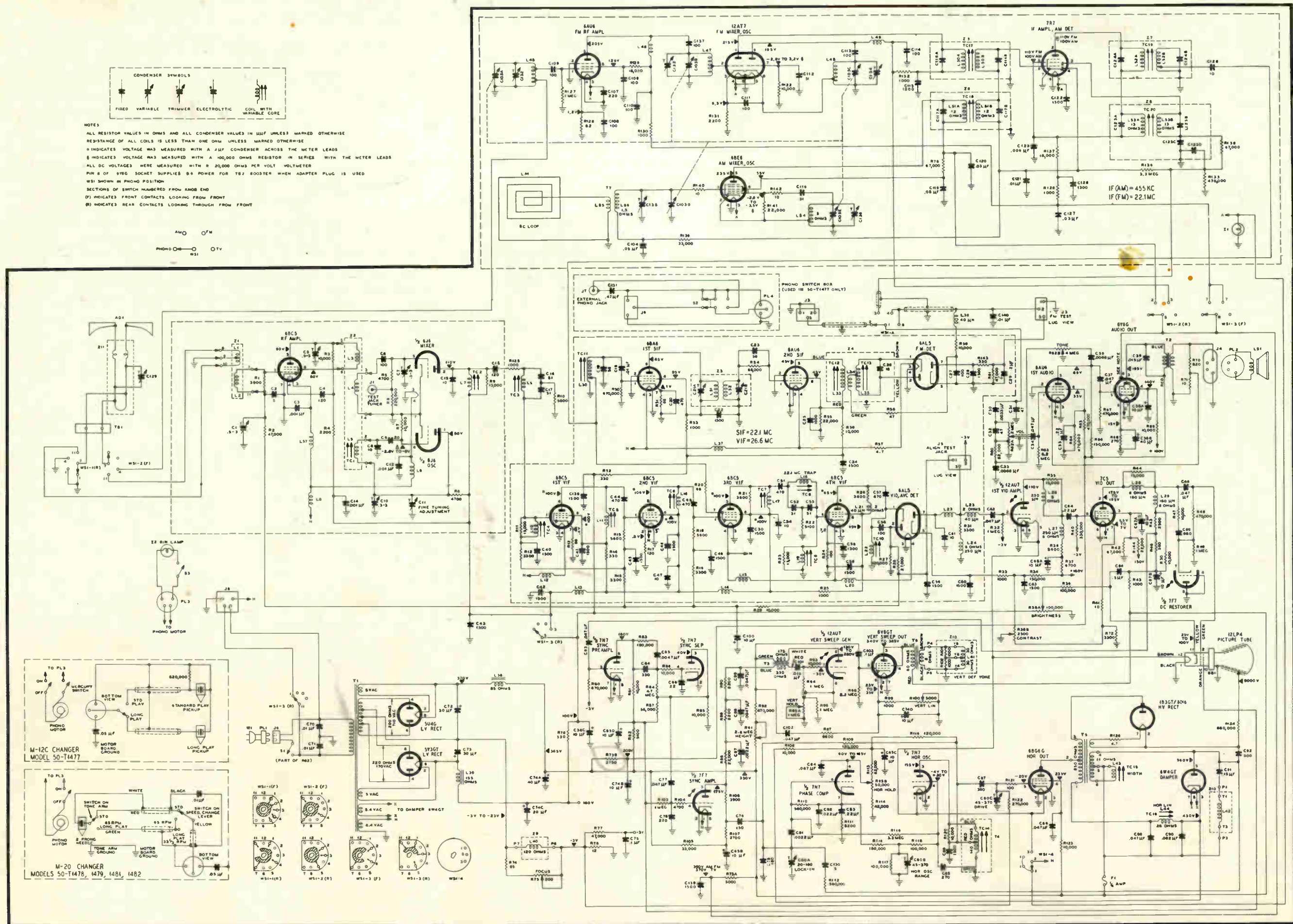

Figure 10. Philco Television-Radio-Phonograph Models 50-T1477, 50-T1478, 50-T1479, 50-T1481, and 50-T1482, Schematic Diagram

## PRODUCTION CHANGES

The deflection chassis and the r-f, i-f chassis carry separate run numbers.

RUN NO.	DESCRIPTION OF CHANGE	REMOVED PART NO.	ADDED PART NO.	REASON FOR CHANGE
2 (Deflection)	Horizontal output screen dropping resistor, R102, 8200 ohms, changed to 6600 ohms, which is made up of 2 resistors in parallel.	66-2825340*	66-3155340* 66-3125340*	To increase high voltage.
2 (Deflection)	Horizontal drive coupling condenser, C87, 680 $\mu\mu\text{f}$ ., changed to 1200 $\mu\mu\text{f}$ .	60-1068514*	60-20125404*	To increase high voltage.
During 2 (Deflection)	R67, 18-ohm resistor in series with focus potentiometer, removed.	66-0185340*		To improve focus range.
2 (R-f, i-f)	Ground strap from 22.1-mc. trap (L6) removed, and replaced with 39-ohm resistor.		66-0398340*	To adjust 22.1-mc. attenuation.
3 1Z 2Z (R-f, i-f)	Ground strap added, in video-i-f wiring.			To reduce harmonic beat.
4 (Deflection)	R95, 56,000-ohm resistor changed to 33,000 ohms.	66-3568340*	66-3338340*	To increase high voltage.
4 (Deflection)	Vertical and horizontal sync separator changed, as shown in figure 1.	66-5128340* (R109) 66-2688340* (R116) 45-3505-62* (C97) 60-10335407* (C96) 62-110009001* (C100)	45-3505-59* (C104) 60-10125237* (C105) 66-4338340* (R125) 66-3568340* (R126) 66-4278340* (R127) 66-5688340* (R128)	To improve sync performance in weak-signal areas.
4 (Deflection)	R53, 10,000-ohm resistor, 4-watt, changed to 5-watt.	66-3104340*	66-3105340*	To prevent overload with high line voltage.
4 (R-f, i-f)	39-ohm resistor in series with 22.1-mc. trap (L6), changed to 15 ohms (added in Run 2).	66-0398350*	66-0158350*	To change 22.1-mc. trap attenuation.
4 (R-f, i-f)	100- $\mu\mu\text{f}$ . condenser added, from pin 5 of Z3 to ground.		62-110009001*	To improve AM rejection of FM detector.
4 (R-f, i-f)	56- $\mu\mu\text{f}$ . condenser added, from pin 2 of video output tube (6AQ5) to ground.		62-056409001*	To reduce lead radiation.
4 (R-f, i-f)	Sound-i-f (intercarrier) amplifier changed, as shown in figure 2.	66-5478340* (R51) 66-4478340* (R52) 62-122001001* (C55)	66-168001001* (C106) 66-2188340* (R129)	To improve sound quality.

## DESCRIPTION OF SYNC CHANGE IN MODELS

### 50-T1600, 50-T1632, AND 50-T1633

The new sync circuit, as used in Run 4, incorporates a section of a 12AU7 connected as a diode and used as a series noise limiter, or noise gate. By making the diode conduct in step with the strength of the received

signal, as reflected in the video-i-f B+ voltage with a-g-c changes, the effects of noise on synchronization are reduced over a great range of signal strength.

## PRODUCTION CHANGES

The following production changes were made since

the printing of Service Bulletin 50T1 (PR-1853).

The high-voltage supply, the r-f, i-f chassis, and the deflection chassis carry separate run numbers.

RUN NO.	DESCRIPTION OF CHANGE	REMOVED PART NO.	NEW OR ADDED PART NO.	REASON FOR CHANGE
5 (R-f, i-f)	The 100- $\mu\mu\text{f}$ . condenser from pin 5 of Z3 was replaced by a trimmer (located between the FM-detector transformer, Z7, and the 6AQ5). See ALIGNMENT NOTE below. 1st s-i-f grid circuit was rewired as in first production.	62-168001001 62-110009001 66-2188340	31-6473-18 trimmer 66-4478340 66-5478340	To improve stability and AM rejection.
5 (Deflection)	C84 changed to silver mica type.	60-10275407	60-10275337	To reduce drift.
6 (Deflection)	C67 increased in ripple-current rating.		30-2568-37*	To reduce heating.
7 (Deflection)	R70 removed. R74 changed to 2700 ohms. R73 changed to 5600 ohms.	66-3228340* 66-2478340* 66-3108340*	66-2278340* 66-2568340*	To simplify wiring.
8 (Deflection)	Fuse holder relocated outside the h-v cage.			To reduce ambient temperature of fuse.
9 (Deflection)	C87 changed to 820 $\mu\mu\text{f}$ .	60-20125404	60-10825401	To reduce interaction between width and linearity adjustments.
10 (Deflection)	A 250- $\mu\mu\text{f}$ ., 50v condenser was added, across focus coil.		30-2417-15	To improve overall focus.
During Run 1 (H-v ass'y.)	Horizontal output transformer changed to 32-8428-1. Wiring of secondary winding changed as shown in figure 5.	32-8428	32-8428-2*	To decrease current in width coil.
2 (H-v ass'y.)	Physical wiring change.			To simplify wiring.
3 (H-v ass'y.)	Fuse relocated outside h-v cage.			To reduce ambient temperature of fuse.

NOTE: All Run 1, 2, 3, and 4 chassis that have Run 5 changes incorporated have a "Y" stamped after the run number. In these chassis, the trimmer referred to above is located underneath the chassis, from pin 5 of Z3 to ground.



## PREPRODUCTION CHANGES IN MODELS 50-T1600, 50-T1632, AND 50-T1633, ALL CODE 122

### MODELS 50-T1600, 50-T1632, AND 50-T1633—REPLACEMENT OF BEAM BENDERS

The beam benders used in the above models may carry Part No. 76-3913-4. These beam benders are more highly magnetized than those of the same part number that are used in other models.

In future production, the beam bender will be Part No. 76-6077. Use this number when ordering replacement beam benders for the above models.

### MODELS 50-T1600, 50-T1632, AND 50-T1633—BLOWN FUSE IN B SUPPLY

Under certain operating conditions, the 1/2-ampere, delayed-action fuse in the B- leg of the power supply may open without there being any overload. Any receiver found with this fuse blown should be checked (check first for overload), then the fuse should be replaced with a 6/10-ampere, delayed-action fuse, Part No. 45-2656-18.

### PREPRODUCTION CHANGES

The following changes were made between the printing of PR-1854 and first production:

- Alignment test points G3, G4, and G5 were removed.
- C107 was changed to 150  $\mu\text{f}$ ., Part No. 30-1220-1.
- A 15,000-ohm resistor, Part No. 66-3158340, was added, between R129 and the wire from pin 6 of the 12AU7 and R139.
- R131 was replaced by a wire.
- R138 was changed to 180,000 ohms, Part No. 66-4188340.
- R121 was changed to 1,000 ohms, Part No. 66-2108340.
- The positions of L21 and L23 were reversed in the circuit.
- The connections to pins 9 and 4,5 of the 12AU7 video detector and a-g-c rectifier tube were reversed.
- The connections to pin 9 and 4,5 of the 12AU7 1st video amplifier tube were reversed.
- The connections to pins 4 and 5 of the 6T8 FM detector and 1st audio tube were reversed.
- The connections to pins 2 and 7 of the 6V6GT audio-output tube were reversed.
- The filament pins of the 6BF5 tube are 3 and 4, instead of 1 and 4.
- R73 was changed to 5600 ohms, Part No. 66-2568340.

- C87 was changed to 820  $\mu\text{f}$ ., Part No. 60-10825401.
- The width coil was rewired as shown in figure 5.

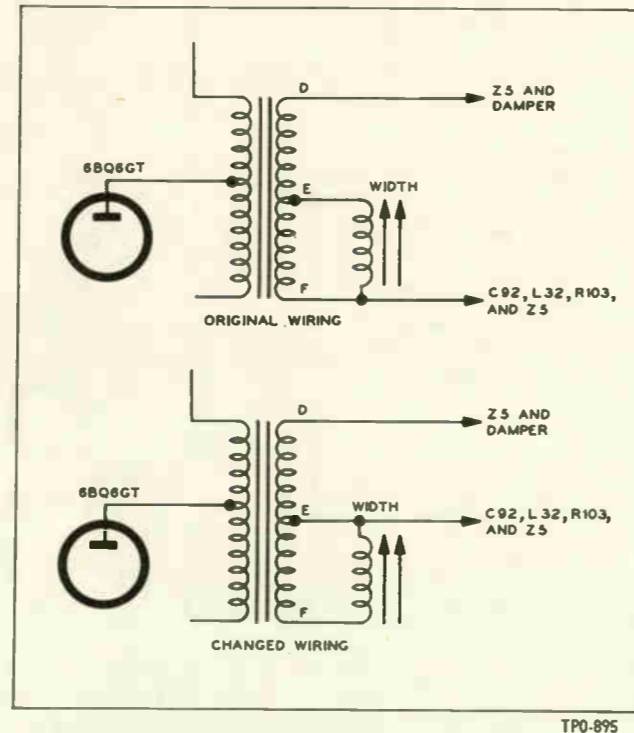

Figure 5. Wiring Changes in Horizontal-Output-Transformer Secondary, Models 50-T1600, 50-T1632, and 50-T1633

### PREPRODUCTION CHANGES

The following changes were made between the printing of PR-1835 and first production.

DESCRIPTION OF CHANGE	REMOVED PART NO.	ADDED PART NO.
1. Voltage-divider resistor R73, in plate circuit of sync inverter, changed to 5600 ohms. Voltage-divider resistor R70 removed. Voltage-divider resistor R74 changed to 2700 ohms.	66-3108340* 66-3228340* 66-2478340*	66-2568340* 66-2278340*
2. Horizontal-oscillator grid blocking condenser, C84, changed to silver mica type.	60-10275407*	60-10275317*

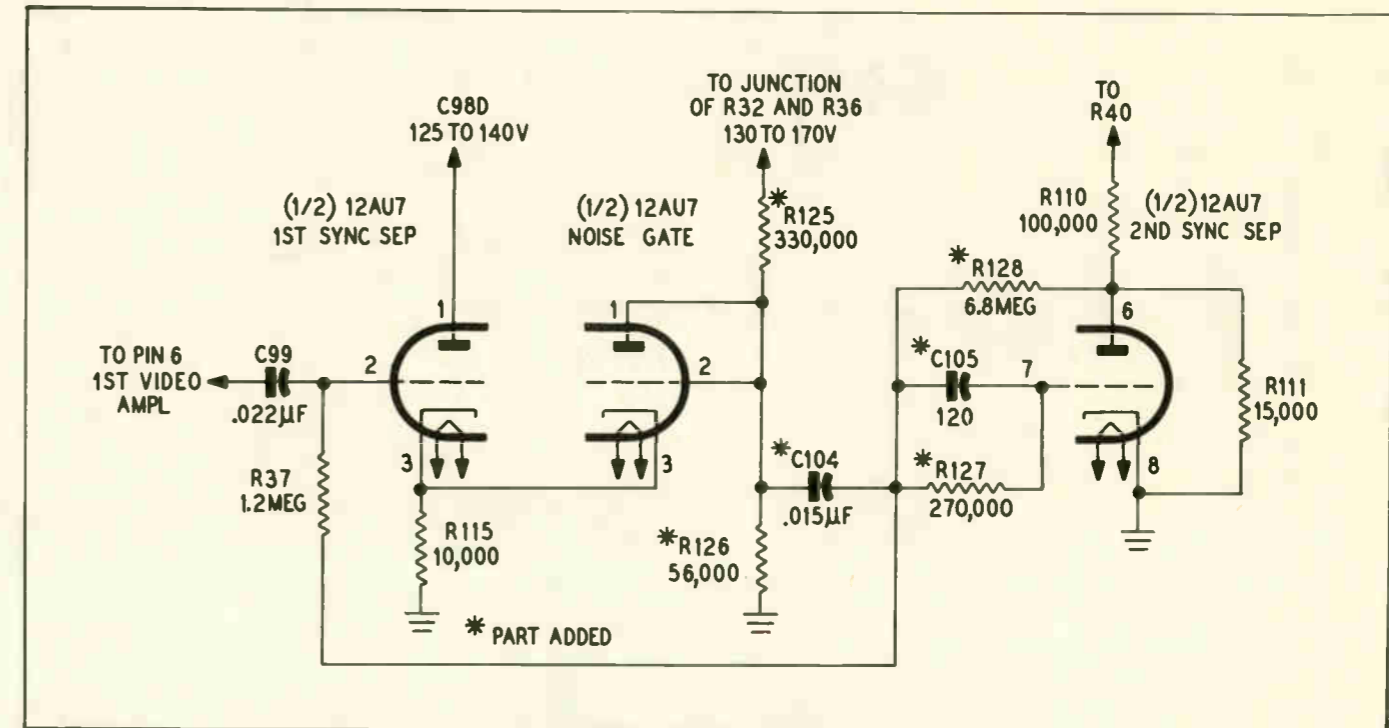

Figure 1. Changes in Sync Separator Circuit, Run 4 of Deflection Chassis, Models 50-T1600, 50-T1632, and 50-T1633

### IMPORTANT:

In figure 9, the schematic diagram, the condenser from the grid, pin 4, of the vert. osc. and discharge tube to ground should be symbolized C74, and the value should be .001  $\mu\text{f}$ .

Philco Television Receiver Models 50-T1600, 50-T1632, and 50-T1633, all Code 122, are similar to Code 121, first production of these models. The main differences are as follows:

- The dual sync separator was changed to a single separator with a series noise gate.
- The 6AL5 video detector and a-g-c rectifier was changed to a 12AU7, which is used as a video detector, a-g-c rectifier and 1st sound-i-f (intercarrier) amplifier.
- The 4.5-mc. trap was moved from the plate of the video-output tube to the output of the video detector.
- The intercarrier sound take-off point was moved from the plate of the first video amplifier to the output of the video detector.
- The a-g-c clamper was removed, and the a-g-c system was changed to variable-delay a.g.c. with sound a-g-c boost.
- The 6/10-ampere delayed-action fuse was moved from inside the high-voltage cage to a point between the high-voltage cage and the chassis power deflection socket, J5.
- A balancing condenser was added to the FM detector circuit.

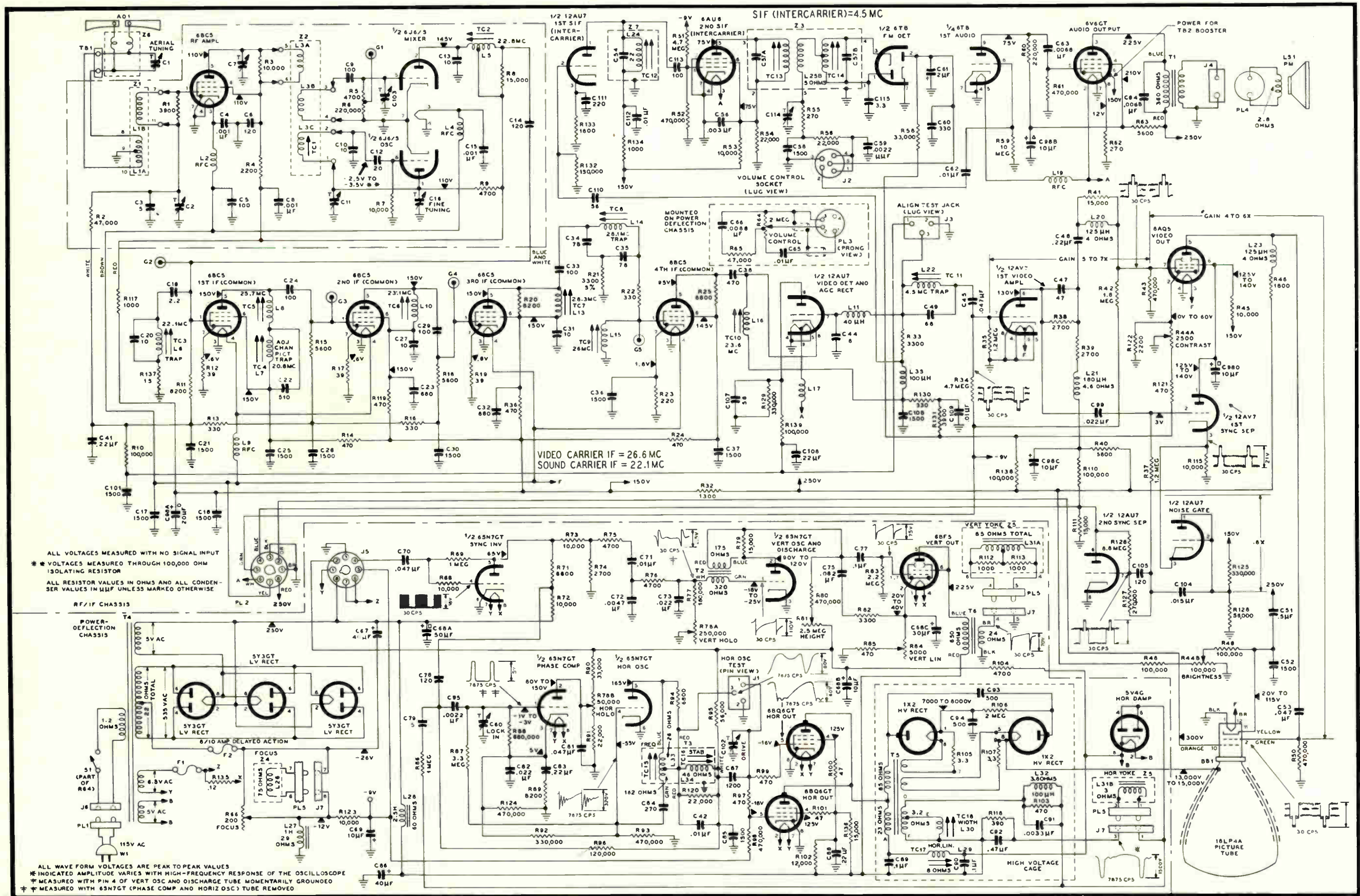

ALL VOLTAGES MEASURED WITH NO SIGNAL INPUT  
 \* VOLTAGES MEASURED THROUGH 100,000 OHM ISOLATING RESISTOR  
 ALL RESISTOR VALUES IN OHMS AND ALL CONDENSER VALUES IN  $\mu$ F UNLESS MARKED OTHERWISE

RF/IF CHASSIS

POWER-DEFLECTION CHASSIS

ALL WAVE FORM VOLTAGES ARE PEAK TO PEAK VALUES  
 \* INDICATED AMPLITUDE VARIES WITH HIGH-FREQUENCY RESPONSE OF THE OSCILLOSCOPE  
 \* MEASURED WITH PIN 4 OF VERT OSC AND DISCHARGE TUBE MOMENTARILY GROUNDING  
 † MEASURED WITH 6SN7GT (PHASE COMP AND HORIZ OSC) TUBE REMOVED

Philco Television Receiver Models 50-T1600, 50-T1632, and 50-T1633, All Code 122, Schematic Diagram

## MODEL 50-T1630

### Corrections to Schematic in Service Manual

The following corrections should be made in the schematic diagram on pages 12 and 13.

1. The wire feeding pin 8 of the top 5Y3GT should be connected to pin 6 of the same tube.
2. The wire feeding pin 6 of the top 5Y3GT should be connected to pin 8 of the same tube.
3. The wire feeding R122, R63, and pin 5 of the horizontal-output transformer should be connected to the 350-volt supply.
4. R82 should be connected to pin 3 of the 6W4GT.
5. The wire connecting pin 3 of the 6W4GT to the 350-volt supply should be removed.
6. R125 should remain connected to the 350-volt supply.

### CORRECTIONS TO SERVICE MANUAL

1. In figure 2 of PR-1791, the wording "PLUG IS SHOWN WITH PRONGS POINTING AWAY" should read "PRONG-END VIEW."
2. The following changes should be made in the schematic diagram:
  - a. The 70-microhenry shunt-peaking coil in the plate circuit of the first-video amplifier should be symbolized L28 instead of L25.
  - b. The filter choke for the negative low-voltage rectifier should be symbolized L32 instead of L132.
  - c. The horizontal-output transformer should be symbolized T7.
  - d. C96 should be connected to the junction of R118 and C92 instead of to the filament lead of the vertical-blocking oscillator.
3. In the Replacement Parts List, the description for C60 should read "Condenser, 4-section, 10-10-10-10  $\mu f$ ." The Service Part No. should be 30-2570-10.

### PRODUCTION CHANGE IN MODEL 50-T1630

RUN NO.	DESCRIPTION OF CHANGE	REASON FOR CHANGE
2	F2 rewired as shown in figure 15.	To reduce a-c current through fuse.

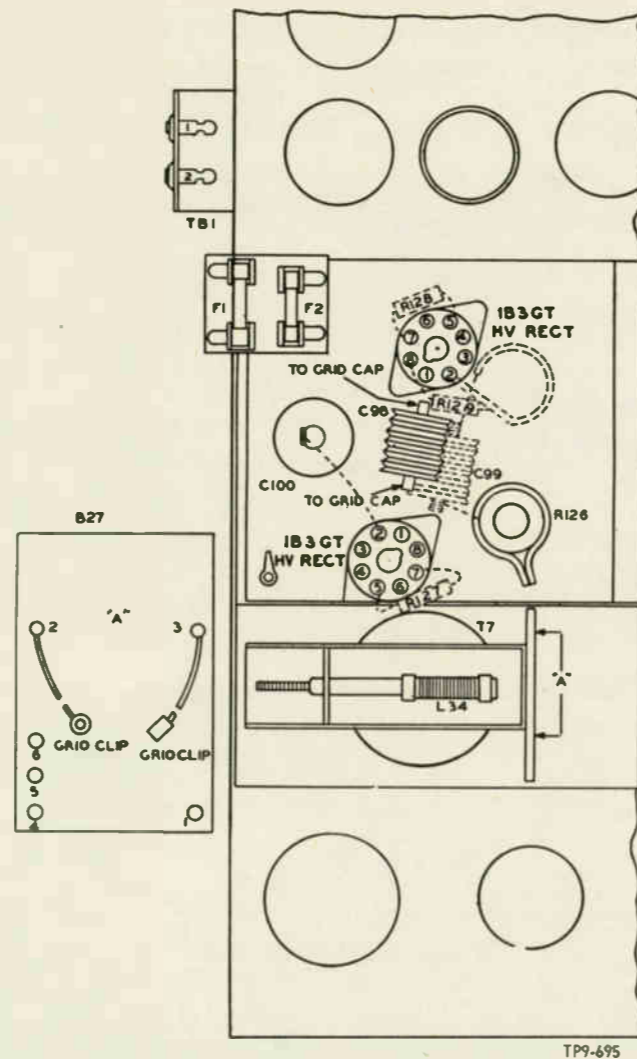



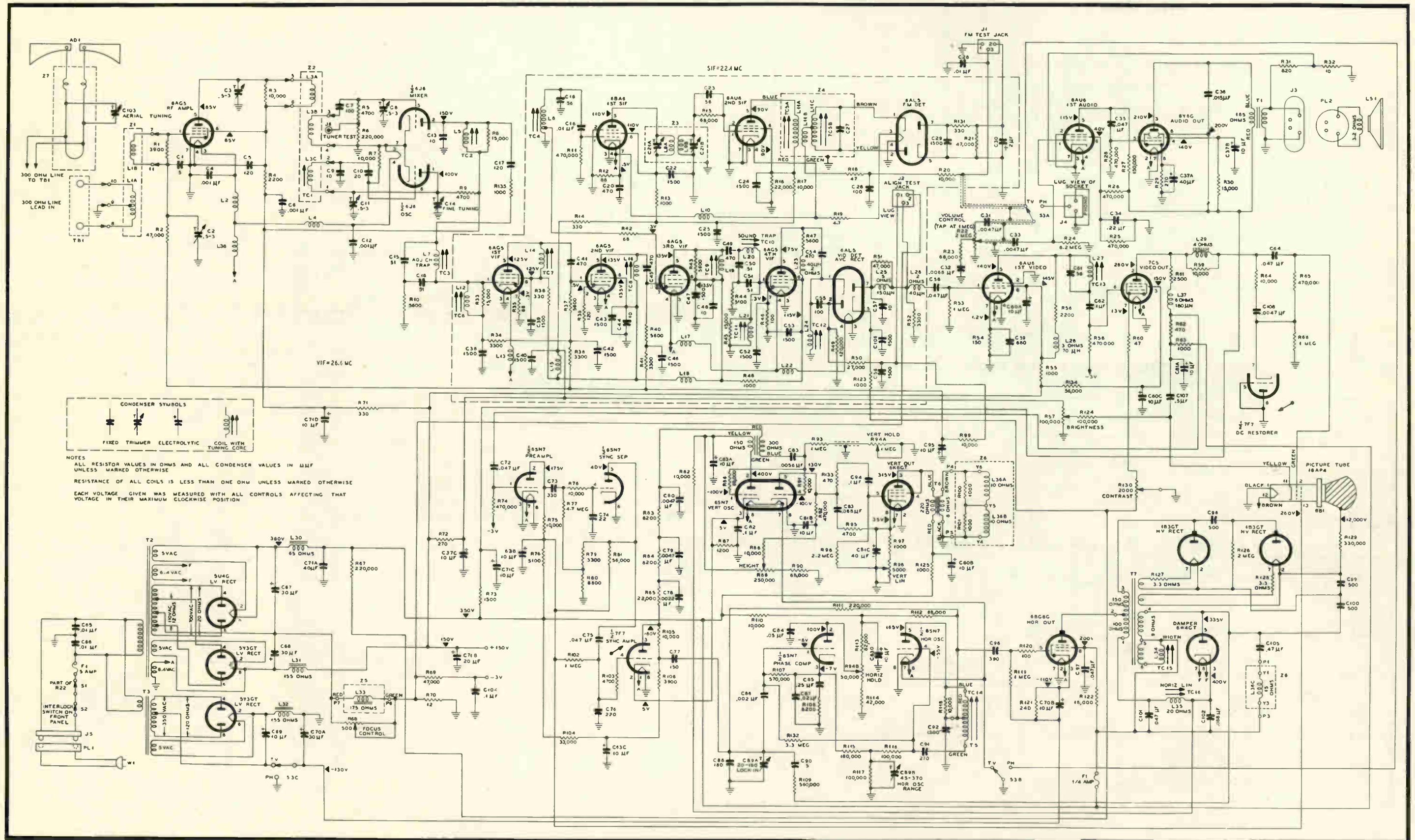

Figure 1. Philco Television Receiver Model 50-T1630, Code 121, Run 3, Schematic Diagram

**PRODUCTION CHANGES IN MODEL 50-T1630**

RUN NO.	DESCRIPTION OF CHANGE	REMOVED PART NO.	ADDED PART NO.	REASON FOR CHANGE
1Z and 2	Lead to C81A removed and connected to C63A. Lead to C63A removed and connected to C81A.			To prevent condenser breakdown.
1Y and 2	Grounded end of C36 disconnected from ground and connected to junction of R26 and R30.			To prevent spurious oscillation.

**PRODUCTION CHANGES IN I-F STRIP FOR MODEL 50-T1630**

RUN NO.	DESCRIPTION OF CHANGE	REMOVED PART NO.	ADDED PART NO.	REASON FOR CHANGE
2	2200-ohm resistor (R131*) added in series with lead between junction of C30 and R21 and junction of C29 and pin 7 of FM-detector tube.		86-2228340	To reduce harmonic beat.
2Z 3	R131* changed from 2200 ohms to 330 ohms.	86-2228340	86-1338340	To facilitate sound-i-f alignment.

The schematic diagram in Service Manual PR-1791 shows R131 as 330 ohms (the value used in runs 2Z and 3), rather than 2200 ohms (the original value used in run 1).

**MODEL 50-T1630, CODE 121**

RUN NO.	DESCRIPTION OF CHANGE	REMOVED PART NO.	ADDED PART NO.	REASON FOR CHANGE
3X and 4	R116 changed from 100,000 ohms to 82,000 ohms.	66-4108340	66-3828340	To center HORIZ. HOLD control.
4	Lead to pin 10 of picture tube removed. Pin 10 reconnected to 350-volt supply.			To increase first-anode voltage of picture tube.

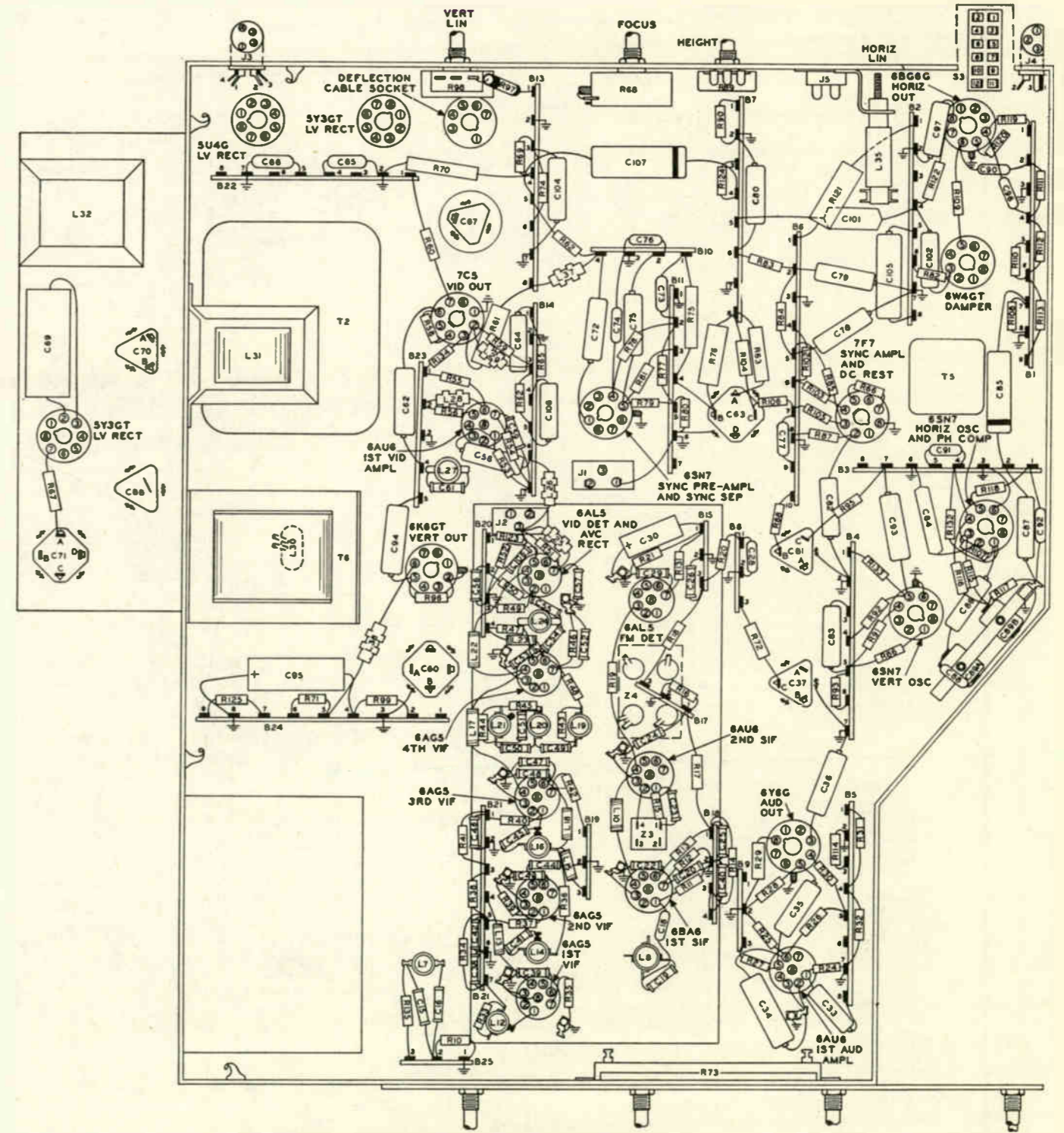

Figure 18. Bottom View of Model 50-T1630, Showing Locations of Components

TP9-697







REASON FOR CHANGE	DESCRIPTION OF CHANGE	NEW OR ADDED PART NO.	OLD OR REMOVED PART NO.	RUN NO.
To improve horizontal linearity.	Horizontal linearity coil changed.	32-4448-3	32-4448-2	2
	Horizontal output transformer changed.	32-8453-1	32-8453	
To reduce ringing in horizontal circuit.	C626 changed from .0033 $\mu$ f. to .004 $\mu$ f.	61-0179	45-3505-55	
	R644 changed from 470 ohms to 330 ohms.	66-1335340	66-1475340	
To reduce screen grid voltage of 6CD6G.	R643 changed from 15,000 ohms to 27,000 ohms.	66-3274340	33-1335-21	
	*35,000-ohm resistor added. Screen grid circuit of 6CD6G rewired.	33-1335-100		
To reduce current flowing in width coil.	C627 and R646 rewired from terminal F to terminal E of T603.			
To improve horizontal linearity.	C624 changed from .082 $\mu$ f. to .068 $\mu$ f.	45-3505-46	30-4651-3	
	C619 changed from 680 $\mu$ f. to 270 $\mu$ f.	60-10275407	60-10685401	
	C629 changed from 10 $\mu$ f., 300V, to 10 $\mu$ f., 450V.	30-2417-6	30-2417-11	
To improve vertical centering and reduce shadow.	*Low end of L101 and black lead of T601 were disconnected from ground and connected together. A 3.3-ohm resistor was added, from the low end of L101 to ground.	66-9334340		3
To improve horizontal-oscillator stability.	R635 changed from 39,000 ohms to 68,000 ohms.	66-3684340	66-3398340	4

PRODUCTION CHANGES IN A1 POWER CHASSIS Page 71

REASON FOR CHANGE	DESCRIPTION OF CHANGE	NEW OR ADDED PART NO.	OLD OR REMOVED PART NO.	RUN NO.
To connect control grid to pin 6 when tube has no internal jumper from pin 3 to pin 6.	6S4 tube socket rewired, with a jumper from pin 3 to pin 6.			2
To limit voltage between earth and chassis ground.	100,000-ohm resistor added, between input side of S100 and ground.	66-4104340		

PRODUCTION CHANGES IN 31 R-F CHASSIS Page 69

REASON FOR CHANGE	DESCRIPTION OF CHANGE	NEW OR ADDED PART NO.	OLD OR REMOVED PART NO.	RUN NO.
To reduce picture bounce.	R220 changed from 3300 ohms to 1000 ohms.	66-2108340	66-2338340	2
	R221 changed from 120,000 ohms to 150,000 ohms. C210 changed from .22 $\mu$ f. to .47 $\mu$ f., 400V.	66-4158340 45-3505-34	66-4128340 45-3505-39	3
To improve tuning range.	Transformer T-200 changed.	32-4486-6	32-4486-13	4
To increase picture brilliance.	R313 changed from 220,000 ohms to 150,000 ohms.	66-4158340	66-4228340	4
To improve picture quality.	R307 changed from 470,000 ohms to 1.2 megohms.	66-5128340	66-4478340	5
	R311 changed from 1800 ohms to 2700 ohms. R304, 5600 ohms, added, video amplifier plate.	66-2275340 66-2564340	66-2185340	
To facilitate production.	Yellow connecting cable lead moved from terminal 8 of B4* to terminal 9 of B4*. White connecting cable lead moved from terminal 9 of B4* to terminal 8 of B4*.			6

PRODUCTION CHANGES IN 3P1 R-F CHASSIS Pages 71 & 78

REASON FOR CHANGE	DESCRIPTION OF CHANGE	NEW OR ADDED PART NO.	OLD OR REMOVED PART NO.	RUN NO.
To improve sync in strong-signal areas.	R606, voltage-divider resistor, plate of noise-gate tube, changed from 240,000 ohms to 180,000 ohms.	66-4188240	66-4248240	7
To improve tone.	C418A, cathode by-pass condenser, audio output, changed from 50 $\mu$ f. to 10 $\mu$ f. C418A replaced with the unused section of C303. 4-section filter condenser.			8

PRODUCTION CHANGES IN 3P1 R-F CHASSIS Pages 71 & 78

REASON FOR CHANGE	DESCRIPTION OF CHANGE	NEW OR ADDED PART NO.	OLD OR REMOVED PART NO.	RUN NO.
To improve picture quality.	R214 changed from 150 ohms to 180 ohms. (See Run 5 change to 220 ohms.)	66-1188340	66-1158340	2
To compensate for peaking of blanking pulse in transmitter.	a. 33- $\mu$ f. condenser added, from grid of noise-gate tube to ground.	62-033009001		3
	b. R408 changed from 15 ohms to 27 ohms. c. C411 changed from .01 $\mu$ f. to .015 $\mu$ f.	66-0273340 45-3505-59	66-0153340 45-3505-58	
To reduce effects of amplitude changes on horizontal sync performance.	d. R316, 100 ohms, added, between cathode, pin 8, of first video amplifier tube and ground.	66-1103340		
	e. C308, .0047 $\mu$ f., added, between cathode, pin 8, of first video amplifier tube and ground.	45-3505-56		
	f. R302 changed from 3900 ohms to 2700 ohms.	66-2278340	66-2398340	
	g. R300 changed from 4.7 megohms to 8.2 megohms.	66-5828540	66-5478540	
	h. R607 changed from 56,000 ohms to 39,000 ohms.	66-3398240	66-3568240	
	i. C210 changed from .22 $\mu$ f. to .47 $\mu$ f. j. C302 changed from 220 $\mu$ f. to 56 $\mu$ f.	45-3505-32 62-056409011	45-3505-49 62-122001001	
To improve picture quality.	R215 changed from 6800 ohms to 5600 ohms.	66-2568340	66-2688340	4
To reduce beat on Channel 5.	10- $\mu$ h. choke added, between L300 and grid, pin 7, of first video amplifier tube.	32-4143-18		5
To improve sync performance in strong-signal areas.	R214 changed from 180 ohms to 220 ohms.	66-1228340	66-1188340	
To improve audio tone quality.	C416 changed from .01 $\mu$ f. to .0047 $\mu$ f. C415 changed from .022 $\mu$ f. to .0068 $\mu$ f. C412 changed from .001 $\mu$ f. to .0068 $\mu$ f. R407 changed from 22,000 ohms to 56,000 ohms.	45-3505-56 45-3505-91 45-3505-40 66-3568340	45-3505-41 45-3505-94 45-3505-35 66-3228340	6

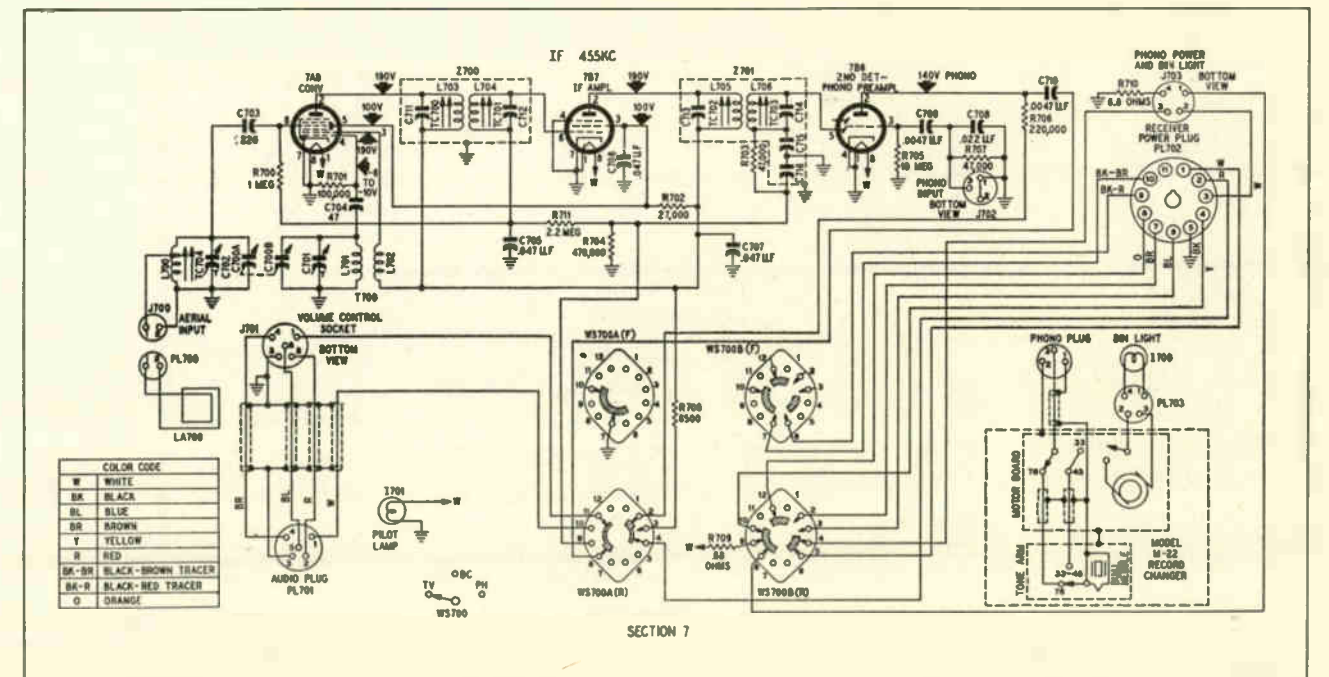

Figure 16. Philco Television-Radio-Phonograph Models 51-T1443PM, 51-T1443PL, and 51-T1443PW, Radio Schematic Diagram Page 71



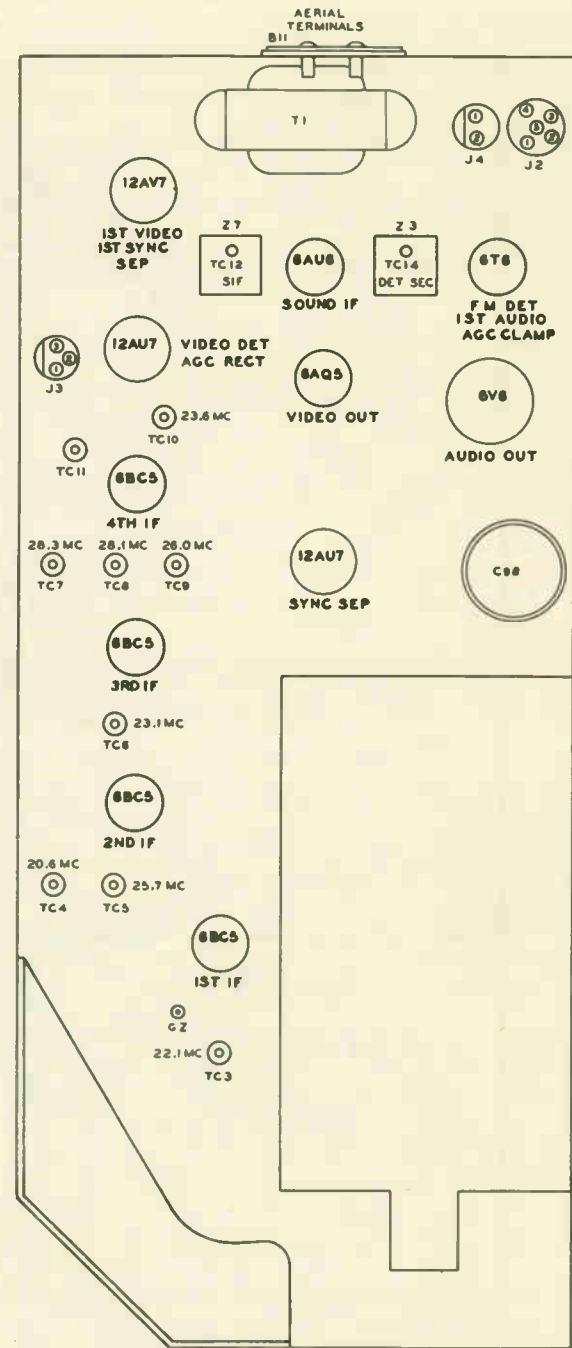
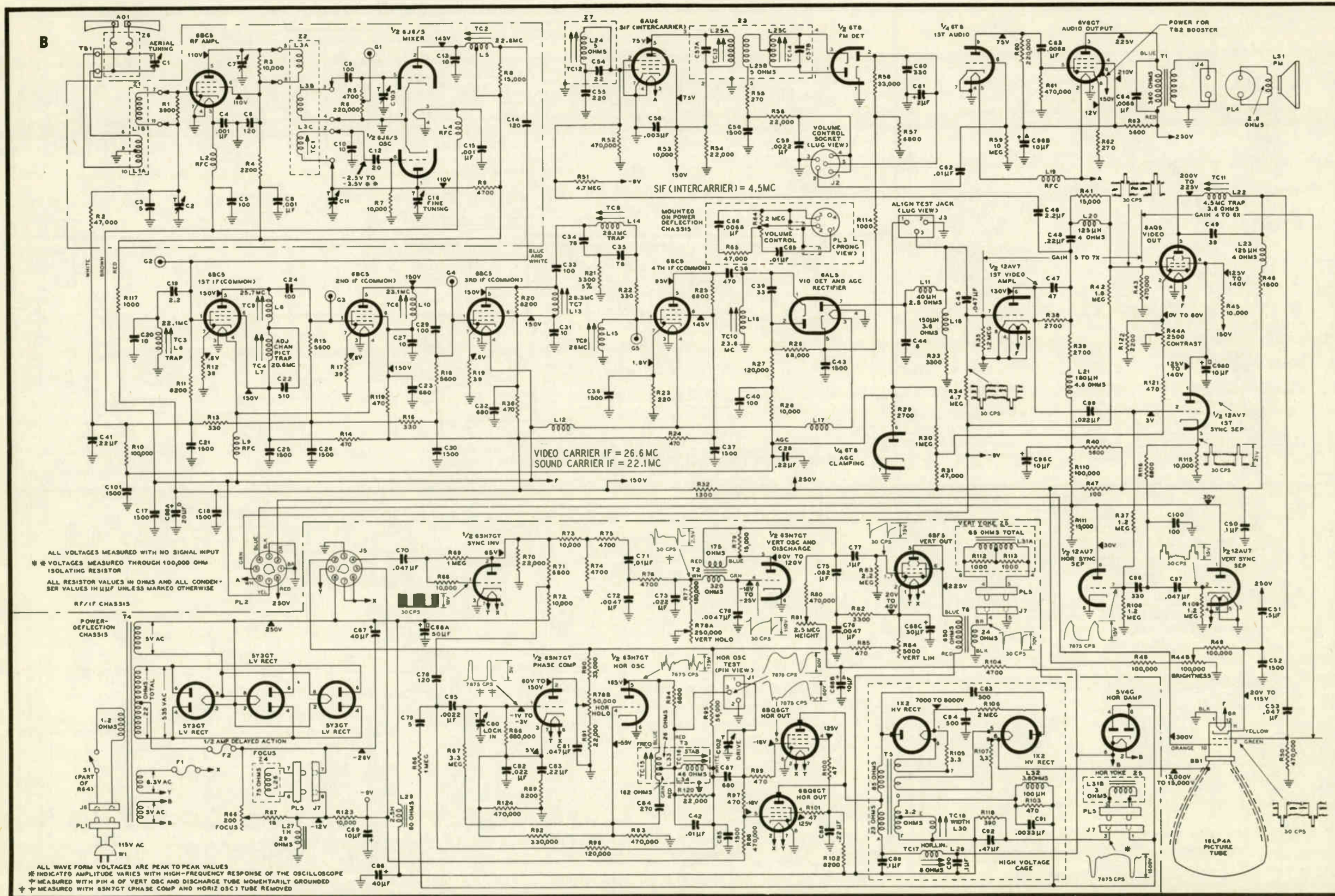

Figure 1. Base Layout for R-F Chassis C, B

Difference in L & J Chassis  
 L Chassis Horiz. Osc. 7N7  
 J Chassis Horiz. Osc. 6SN7  
  
 L Chassis Vert. Osc. 7N7  
 J Chassis Vert. Osc. 6SN7  
  
 Difference in B & C Chassis  
 Tuner used on B Chassis Page 70  
 Tuner used on C Chassis Page 71

Production Changes Pages 74 & 75  
 Power Chassis Layout Page 75

Television Schematic Diagram Models 51-T1604, CODE 122, and 51-T1634, CODE 122, (Using "B" R-F Chassis and J Deflection Chassis.)  
 Television Schematic Diagram Models 51-T1604, CODE 125, and 51-T1634, CODE 125, (Using "B" R-F Chassis and L Deflection Chassis.)  
 Television Schematic Diagram Models 51-T1604, CODE 121, and 51-T1634, CODE 121, (Using "C" R-F Chassis and L Deflection Chassis.)



Tuner Part No. 76-5747, Schematic Diagram

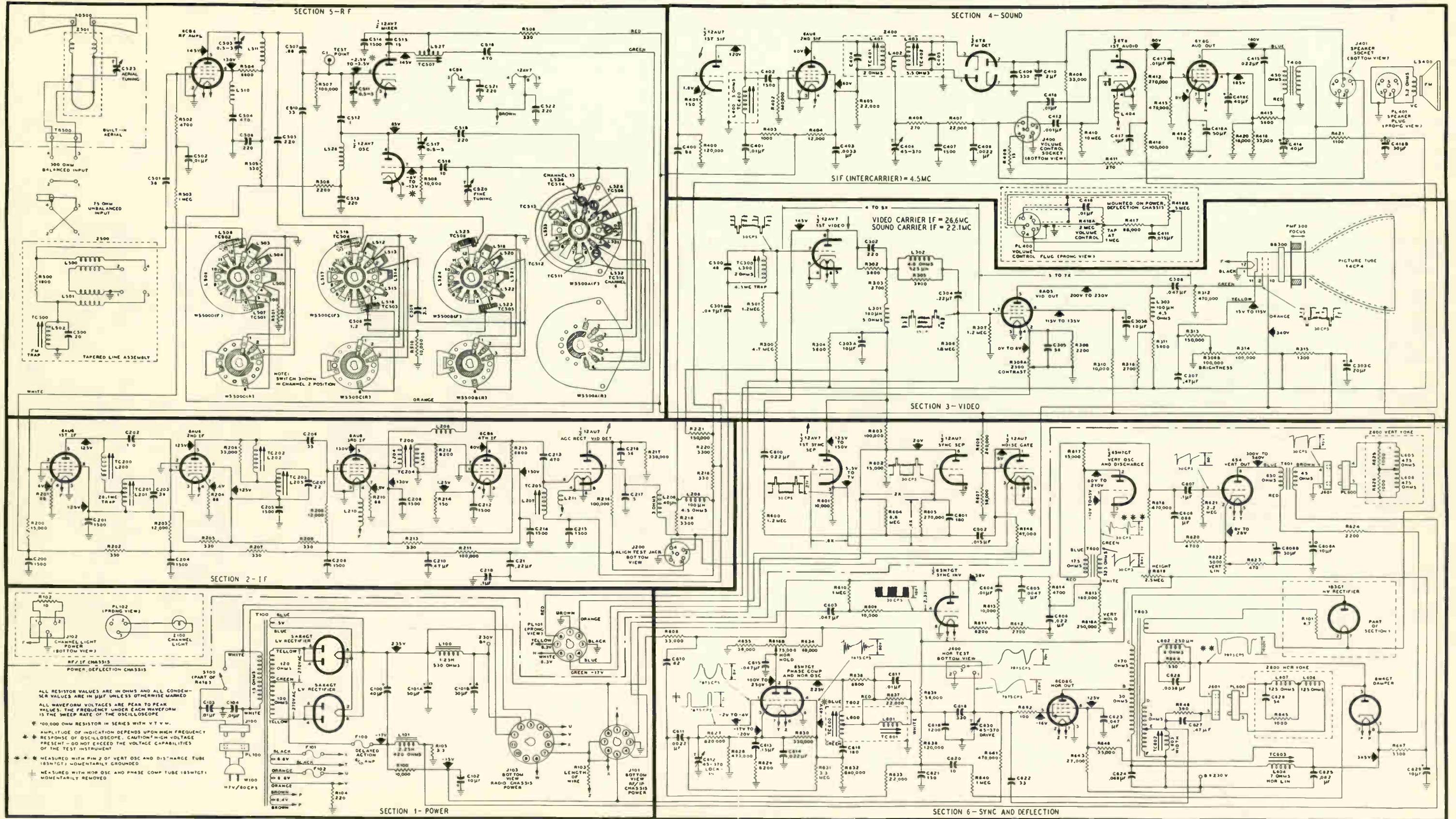

Television Schematic Diagram Models 51-T1443PM, 51-T1443PL, and 51-T1443PW (Using 3P1 R-F Chassis and AP-1 Deflection Chassis.)

PRODUCTION CHANGES IN CP1 DEFLECTION CHASSIS Page 79

REASON FOR CHANGE	DESCRIPTION OF CHANGE	NEW OR ADDED PART NO.	OLD OR REMOVED PART NO.	RUN NO.
To increase width of picture.	820- $\mu$ f. condenser added, across width coil.	60-10825011		13
To increase width of picture.	R643, screen dropping resistor, horiz. output tube, changed from 15,000 ohms, 5 watts, to 12,000 ohms, 5 watts.	33-1335-103	33-1335-23	14
	C634, width condenser, changed from .0022 $\mu$ f., 600V, to .0033 $\mu$ f., 600V.	30-4650-55	30-4650-54	
To improve tone.	C416, d-c blocking condenser, changed from .01 $\mu$ f., 400V, to .0047 $\mu$ f., 600V.	30-4650-56	30-4650-41	15
To improve range of HEIGHT control.	R618, sweep charging resistor, changed from 1.5 megohm to 1 megohm.	66-5108340	66-5158340	
To improve operation of vertical linearity control.	R622, vertical linearity control, changed from 5000 ohms to 2500 ohms.	33-5546-40	33-5546-10	
To improve operation of vertical linearity control.	R623, vertical linearity limiting resistor, changed from 470 ohms to 820 ohms.	66-1824346	66-1474346	16
	R649, shaping resistor, changed from 100,000 ohms, 1 watt, to 180,000 ohms, 1 watt.	66-4184546		

PRODUCTION CHANGES IN C2 DEFLECTION CHASSIS Page 81

REASON FOR CHANGE	DESCRIPTION OF CHANGE	NEW OR ADDED PART NO.	OLD OR REMOVED PART NO.	RUN NO.
To improve operation of vertical linearity control.	R622, vertical linearity control, changed from 5000 ohms to 2500 ohms.	33-5546-40	33-5546-10	5
	R623, vertical linearity limiting resistor, changed from 4700 ohms to 820 ohms.	66-1824346	66-2474346	
To facilitate production.	R109, B plus dropping resistor, changed to new type resistor.	33-3347-3	33-3445-2	6
To increase height of picture.	Added R650, a 1.5-megohm resistor, from open end of R619, vertical height control, to ground.	66-5158546		7
To increase width of picture.	C634, width condenser, changed from .0033 $\mu$ f., 600V, to .0047 $\mu$ f., 1000V.	30-4650-90	30-4650-55	8
To protect power transformer.	A 5-ampere fuse was added, in series with J100, a-c power jack and S100, a-c power switch.	45-2656-25		9

PRODUCTION CHANGES IN 32, 33, and 34 R-F CHASSIS Page 73 & 81

REASON FOR CHANGE	DESCRIPTION OF CHANGE	NEW OR ADDED PART NO.	OLD OR REMOVED PART NO.	RUN NO.
To improve picture quality.	R214 changed from 150 ohms to 180 ohms.	66-1188350	66-1158350	2
To compensate for peaking of blanking pulse at transmitter.	C635, 33- $\mu$ f., added, from pin 2 of noise-gate tube (12AU7) to ground.	62-033009001		3
To improve picture quality.	R215 changed from 6800 ohms to 5600 ohms.	66-2568343	66-2688343	4
To reduce oscillator beats on Channel 5.	L304, 10- $\mu$ h. choke, added, in series with first video grid-input circuit.	32-4143-18		5
To improve sync performance in strong-signal areas.	R214 changed from 180 ohms to 220 ohms.	66-1224340	66-1188350	6
To improve sync performance in strong-signal areas.	R606 changed from 240,000 ohms to 180,000 ohms.	66-4188240	66-4248240	7
To facilitate production.	R310, 10,000 ohms, removed. Discontinued use of C303B, a part of C303. C303, electrolytic condenser, changed from 3 section to 4 section. C308 removed. Added section of C303 used in the place of this condenser.	30-2570-70	30-2570-65 30-2570-25	8

Figure 21. Dummy Radio Power Plug Used in Models 51-T1838, Code 124; 51-T1870, 51-T2134, Code 124; 51-T2136, Code 124; and 51-T2138, Code 124

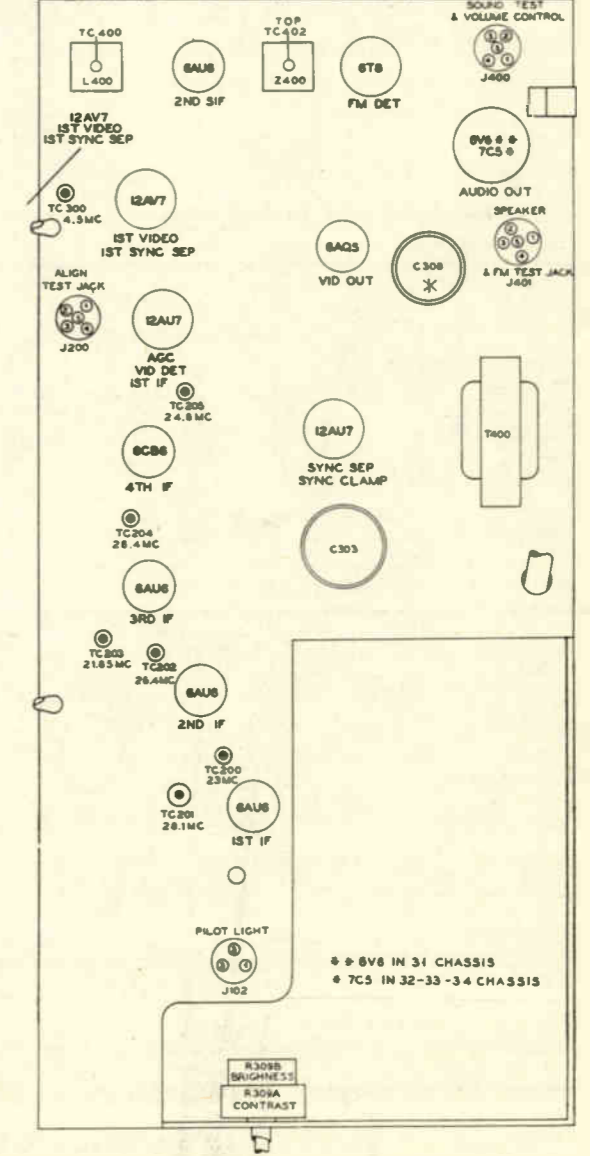
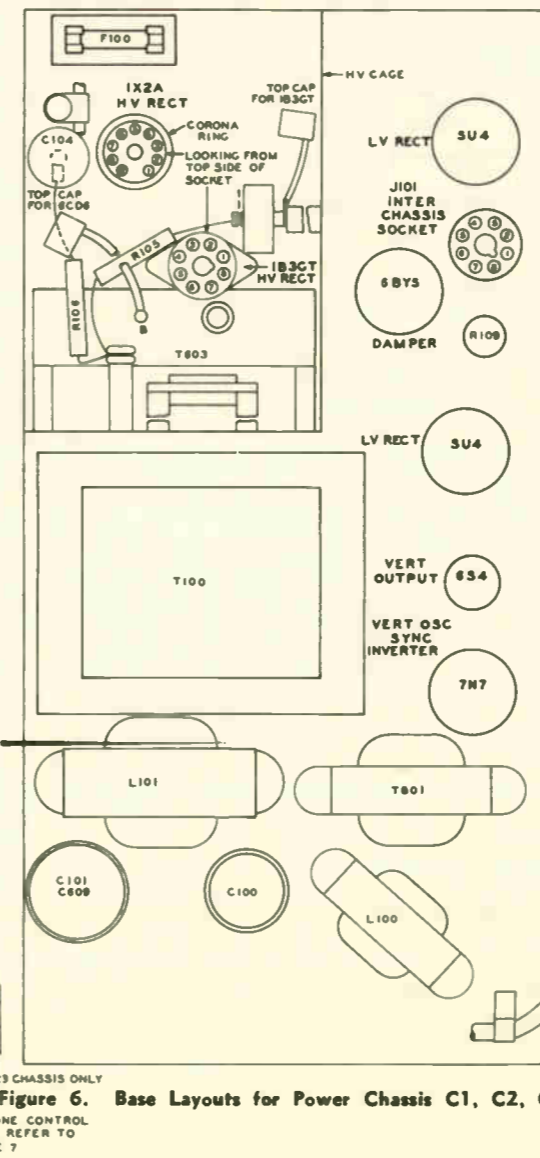
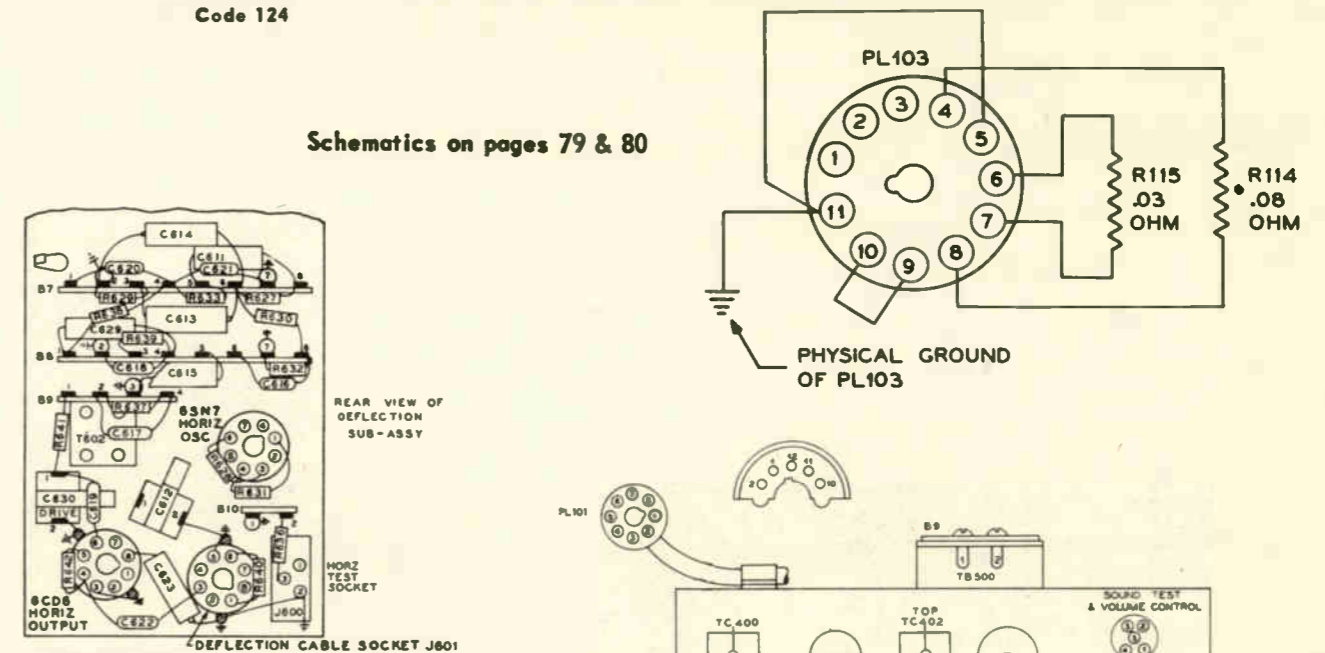
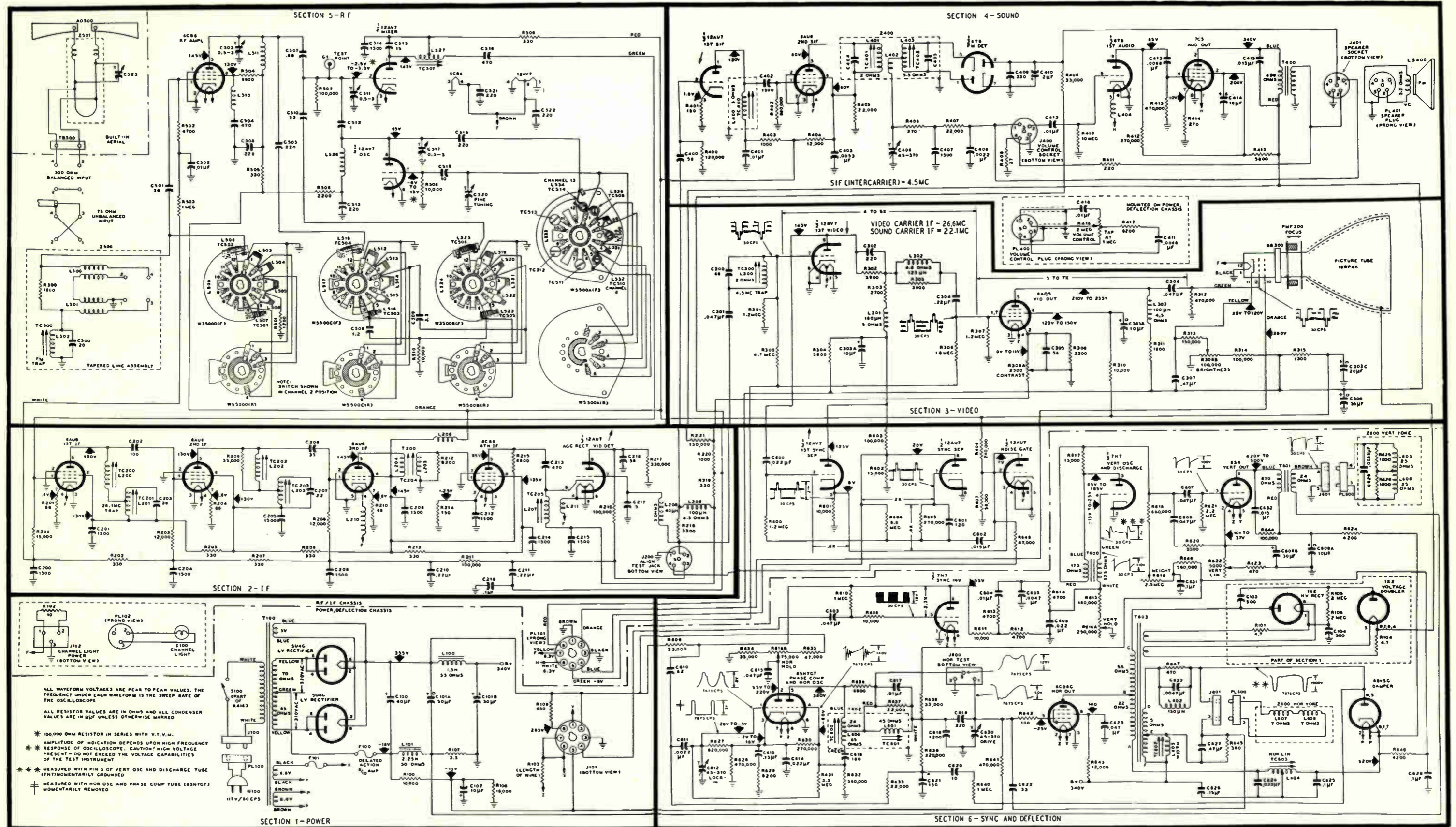

Figure 1. Base Layouts for R-F Chassis 31, 32, 33, 34

3P1 Layout



Television Schematic Diagram Models 51-T1601, CODE 121, 51-T1601T, CODE 121, 51-T1602, CODE 121, 51-T1607, CODE 121, 51-T1634, CODE 123 (Using 33 R-F Chassis and C-1 Deflection Chassis.)  
 51-T1601, CODE 122, 51-T1601T, CODE 122, 51-T1602, CODE 122, 51-T1607, CODE 122, 51-T1634, CODE 124 (Using 32 R-F Chassis and C-1 Deflection Chassis.) Production Changes on pages 72, 74 & 78.  
 The Difference in 33 RF Chassis & 32 RF Chassis is the Tuner used. The 32 RF Tuner is on page 75. 33 RF is used in the above Schematic.

TPO-1443

## PRODUCTION CHANGES IN B AND C R-F CHASSIS

The schematic diagram in Service Manual PR-1854 does not correspond to first production of the B and C chassis. To bring the schematic up to first production, the following corrections should be made:

1. Remove condenser C111 from the schematic.

2. Change the value of R133 from 1800 ohms to 150 ohms.
3. Change the value of C107 from 56  $\mu\text{mf.}$  to 150  $\mu\text{mf.}$
4. Change the value of R121 from 470 ohms to 1000 ohms.
5. Change the value of R138 from 100,000 ohms to 180,000 ohms.
6. Add a 15,000-ohm resistor, in series with the plate (pin 6) of the a-g-c rectifier tube (12AU7).

### RUN CHANGES FOR B AND C R-F CHASSIS Page 70

REASON FOR CHANGE	DESCRIPTION OF CHANGE	NEW OR ADDED PART NO.	OLD OR REMOVED PART NO.	RUN NO.
To facilitate production.	Strap wire added, between lug 3 and lug 4 of PL3.			2
To improve video response.	L21 changed from 180 $\mu\text{h.}$ to 125 $\mu\text{h.}$	32-4143-6	32-4143-13	3
To improve picture quality in weak-signal areas.	C47 changed from 47 $\mu\text{mf.}$ to 100 $\mu\text{mf.}$ L23 changed from 125 $\mu\text{h.}$ to 100 $\mu\text{h.}$	62-110009001 32-4143-17	62-047009001 32-4143-12	4
To improve trap rejection.	R137, 15 ohms, removed.		66-0158340	5
To prevent video output plate-load resistor overload.	R43 changed from 470,000 ohms to 1.2 megohms.	66-5128340	66-4478340	6

### PRODUCTION CHANGES IN C1 POWER CHASSIS Page 73

REASON FOR CHANGE	DESCRIPTION OF CHANGE	NEW OR ADDED PART NO.	OLD OR REMOVED PART NO.	RUN NO.
To remove shadow from picture tube.	Red lead of power choke L101 disconnected from R107. Junction of C101A and L101 connected to ground.			2
To improve sweep width.	R643 changed from 12,000 ohms to 8200 ohms. Condenser C636, originally omitted, was added to the revised schematic. The value, .0033 $\mu\text{f.}$ , was changed to .0047 $\mu\text{f.}$ in this run.	33-1335-108 45-3505-56	33-1335-103	3
To reduce screen shadow.	R643, 12,000 ohms, rewired from B+315 volts to junction of C627 and pin 3 of J601.			4
To reduce screen shadow.	R107, 3.3-ohm resistor, in series with the secondary of the vertical output transformer T601, was removed. The black lead of the transformer and the low end of L101 were connected to ground.		66-9334360	5
To improve vertical linearity.	R620 changed from 3300 ohms to 8200 ohms.	66-2828340	66-2338340	
To reduce picture bounce.	a. R649, 560,000 ohms, removed. b. R649 added to schematic, between cathode of 6BY5G damper tube and junction of height control and C631. The value of this resistor is 18,000 ohms. c. R635 changed from 47,000 ohms to 82,000 ohms, 1 watt. d. R634 changed from 33,000 ohms to 47,000 ohms. e. R108, 18,000 ohms, removed. f. R107, 100,000 ohms, added, between R100 and pin 5 of J101* g. R108, 150,000 ohms, added, between pin 5 of J101* and ground.	66-3184340 66-3828340 66-3478340 66-3188340 66-4108340 66-4158340	66-4564340 66-3478340 66-3338340 66-3188340	6
To reduce line-voltage fluctuations.	h. C631 changed from .1 $\mu\text{f.}$ to 10 $\mu\text{f.}$ , 475V.	30-2417-19	45-3505-47	

7. Add a 56- $\mu\text{mf.}$  condenser, from the cathode (pin 2) of the video output tube (6AQ5) to ground.
8. Remove R131, and put a jumper in its place.

9. Move the connection of R128 from pin 2 of the second sync separator tube to the junction of C104, C105, R37, and R127.

### PRODUCTION CHANGES IN C1 POWER CHASSIS

Page 73

REASON FOR CHANGE	DESCRIPTION OF CHANGE	NEW OR ADDED PART NO.	OLD OR REMOVED PART NO.	RUN NO.
To center vertical hold control.	R615 changed from 180,000 ohms to 270,000 ohms.	66-4278340	66-4188340	7
To eliminate oscillation beats on Channel 5 when built-in aerial is used.	L609*, 10- $\mu\text{h.}$ choke, added, in series with damper-tube plate.	32-4112-24		8
To improve sync performance.	R111 changed from 22,000 ohms to 27,000 ohms, 2 watts.	66-3275340	66-3224340	9
To connect control grid to pin 6 when tube has no internal jumper from pin 3 to pin 6.	6S4 tube socket rewired, with a jumper from pin 3 to pin 6.			10
To limit voltage between earth and chassis ground.	R110*, 100,000 ohms, added, between input side of S100 and ground.	66-4104340		
	High-voltage assembly changed, replacing input 1X2 tube with 1B3GT.	76-6664	76-6282	11
To improve HEIGHT control range.	R618 changed from 680,000 ohms to 1.5 megohms. (See Run 15 change.)	66-5158340	66-4688340	12
To improve vertical interlace.	R620 changed from 8200 ohms to 6800 ohms.	66-2688340	66-2828340	13
To increase width of picture.	C636 (originally omitted from schematic) changed from .001 $\mu\text{f.}$ to .0056 $\mu\text{f.}$	45-3505-54	45-3505-52	14
To improve range of height control.	R618 changed from 1.5 megohms to 1 megohm.	66-5108340	66-5158340	15

\* This reference symbol refers to a new part in the revised schematic diagram in Service Manual PR-1928.

### PRODUCTION CHANGES IN C3 POWER CHASSIS Page 77

REASON FOR CHANGE	DESCRIPTION OF CHANGE	NEW OR ADDED PART NO.	OLD OR REMOVED PART NO.	RUN NO.
	Same as Run 5 of C1 chassis.			2
To improve horizontal linearity.	C625 changed from .1 $\mu\text{f.}$ to .22 $\mu\text{f.}$	54-3505-49	45-3505-64	3
To center range of vertical hold control.	R615 changed from 180,000 ohms to 270,000 ohms.	66-4278340	66-4188340	
	Same as Run 8 of C1 chassis.			4
To improve sync performance.	R111 changed from 22,000 ohms to 27,000 ohms.	66-3275340	66-3225340	5
To facilitate production.	a. Jumper lead between pin 7 of one 5U4 to pin 1 of J103 removed. Leads connected to pin 7 of the 5U4 were removed, and connected to pin 1 of J103. All chassis of previous run numbers which had this change incorporated were designated by an "X"			6
To connect control grid to pin 6 when tube has no internal jumper from pin 3 to pin 6.	b. 6S4 tube socket rewired, with a jumper from pin 3 to pin 6.			
To limit voltage between earth and chassis ground.	c. 100,000-ohm resistor added, between input side of S100 and ground.	66-4104340		
To facilitate production.	High-voltage assembly changed.	76-6664	76-5000	7
	Same as Run 12 of C1 chassis.			8
	Same as Run 13 of C1 chassis.			9

### PRODUCTION CHANGES IN J AND L POWER CHASSIS

The schematic diagram in Service Manual PR-1854 does not correspond to first production of the J and L chassis. To bring the schematic up to first production, the following corrections should be made:

1. Change the value of C78 from 120  $\mu\text{f.}$  to 180  $\mu\text{f.}$

2. Change the value of C87 from 1200  $\mu\text{f.}$  to 820  $\mu\text{f.}$
3. Change the value of R95 from 56,000 ohms to 33,000 ohms.
4. Add a 250- $\mu\text{f.}$  electrolytic condenser, in parallel with the focus coil.
5. Move all connections from the junction of L30 and terminal F of T5 to the junction of L30 and terminal E of T5.

### RUN CHANGES FOR J AND L POWER CHASSIS Page 70

REASON FOR CHANGE	DESCRIPTION OF CHANGE	NEW OR ADDED PART NO.	OLD OR REMOVED PART NO.	RUN NO.
To allow tuning of horizontal-oscillator coil when using a 7N7 tube.	R92 changed from 330,000 ohms to 270,000 ohms.	66-427824	66-4338240	3
To improve vertical sync.	R73 changed from 5600 ohms to 10,000 ohms. R71 changed from 6800 ohms to 15,000 ohms. R74, 2700 ohms, removed. R75, 4700 ohms, removed. R70, 6800 ohms, added, from plate of sync inverter tube to chassis. C71 connected to open end of R73. Connection of C78 moved from junction of R71 and R72 to junction of R70, R71, and R73.	66-3108340 66-3155340   66-2688340	66-2568340 66-2685340 66-2278340 66-2478340	4

### PRODUCTION CHANGES IN 3R2 R-F CHASSIS Page 80

REASON FOR CHANGE	DESCRIPTION OF CHANGE	NEW OR ADDED PART NO.	OLD OR REMOVED PART NO.	RUN NO.
To improve sync in strong-signal areas.	R606, voltage-divider resistor, plate of noise-gate tube, changed from 240,000 ohms to 180,000 ohms.	66-4188240	66-424840	4

### PRODUCTION CHANGES IN 3R2 CHASSIS Page 80

REASON FOR CHANGE	DESCRIPTION OF CHANGE	NEW OR ADDED PART NO.	OLD OR REMOVED PART NO.	RUN NO.
To improve picture quality.	R215 changed from 6800 ohms to 5600 ohms.	66-2568340	66-2688340	2
To reduce beat on Channel 5.	10- $\mu\text{h.}$ choke added, between L300 and grid, pin 7, of first video amplifier tube.	32-4143-18		
To improve sync performance in strong-signal areas.	R214 changed from 180 ohms to 220 ohms.	66-1228340	66-1188340	3

### PRODUCTION CHANGES IN CR3 DEFLECTION CHASSIS Page 80

REASON FOR CHANGE	DESCRIPTION OF CHANGE	NEW OR ADDED PART NO.	OLD OR REMOVED PART NO.	RUN NO.
To improve HEIGHT control range.	Changed R618, vertical charging resistor, from 1.5 megohms to 1 megohm.	66-5108340	66-5158340	2

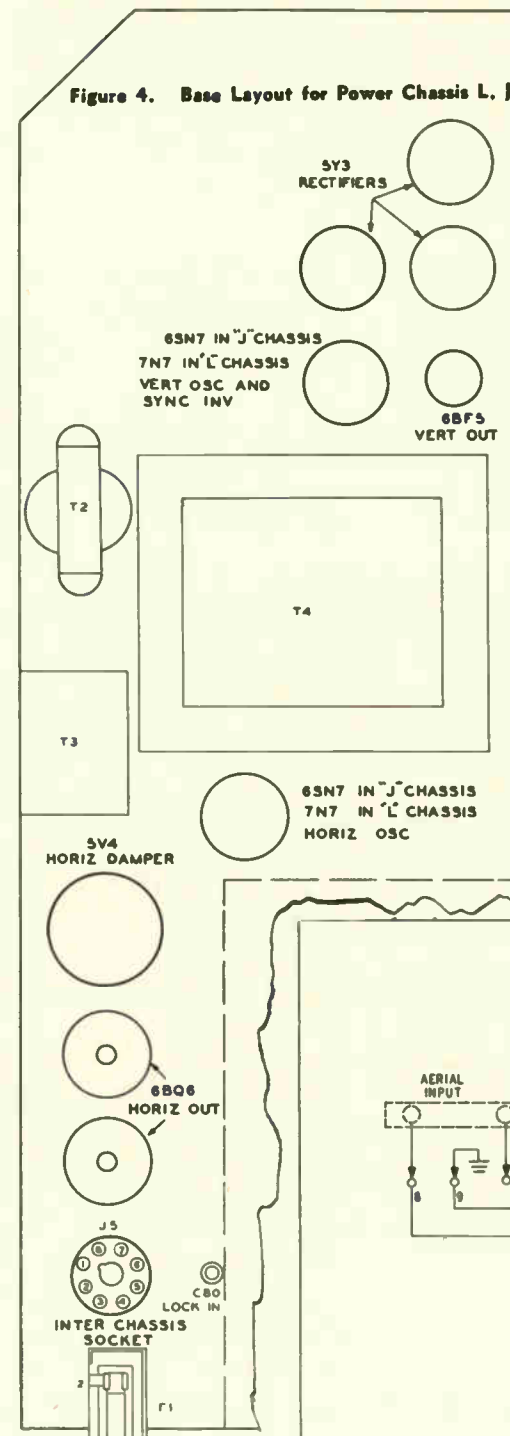

Figure 4. Base Layout for Power Chassis L, J

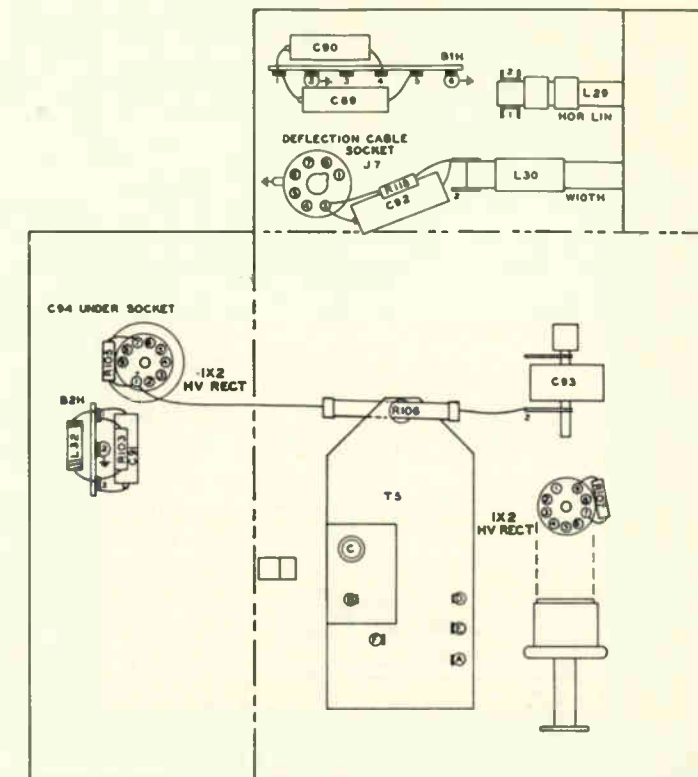
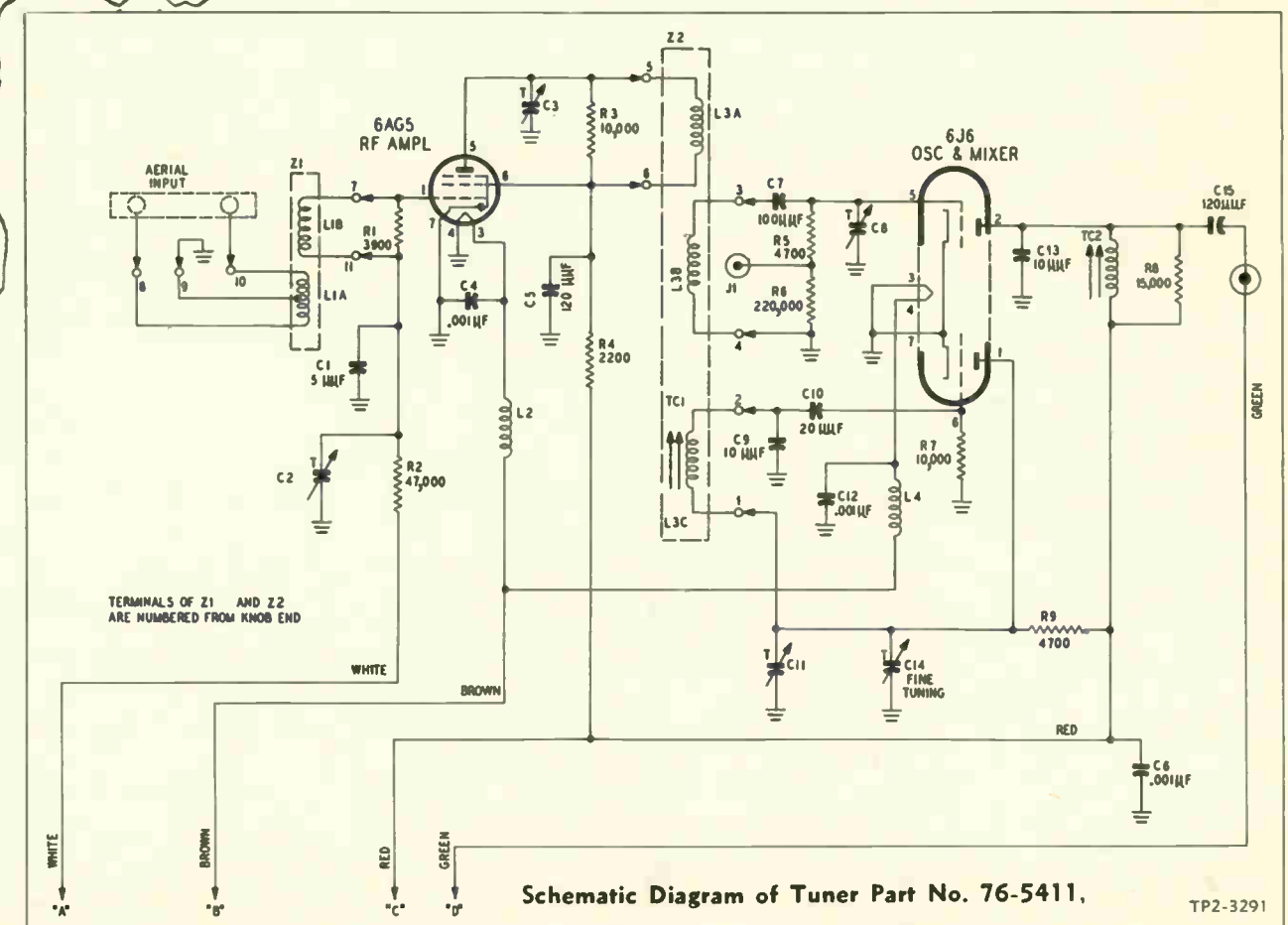

Figure 5. Base Layout for High-Voltage Subassembly of Power Chassis L, J



Schematic Diagram of Tuner Part No. 76-5411,

TP2-3291

Figure 22. Schematic Diagram, Radio AM Tuner RT-4, Page 79 & 80 TPO-1458

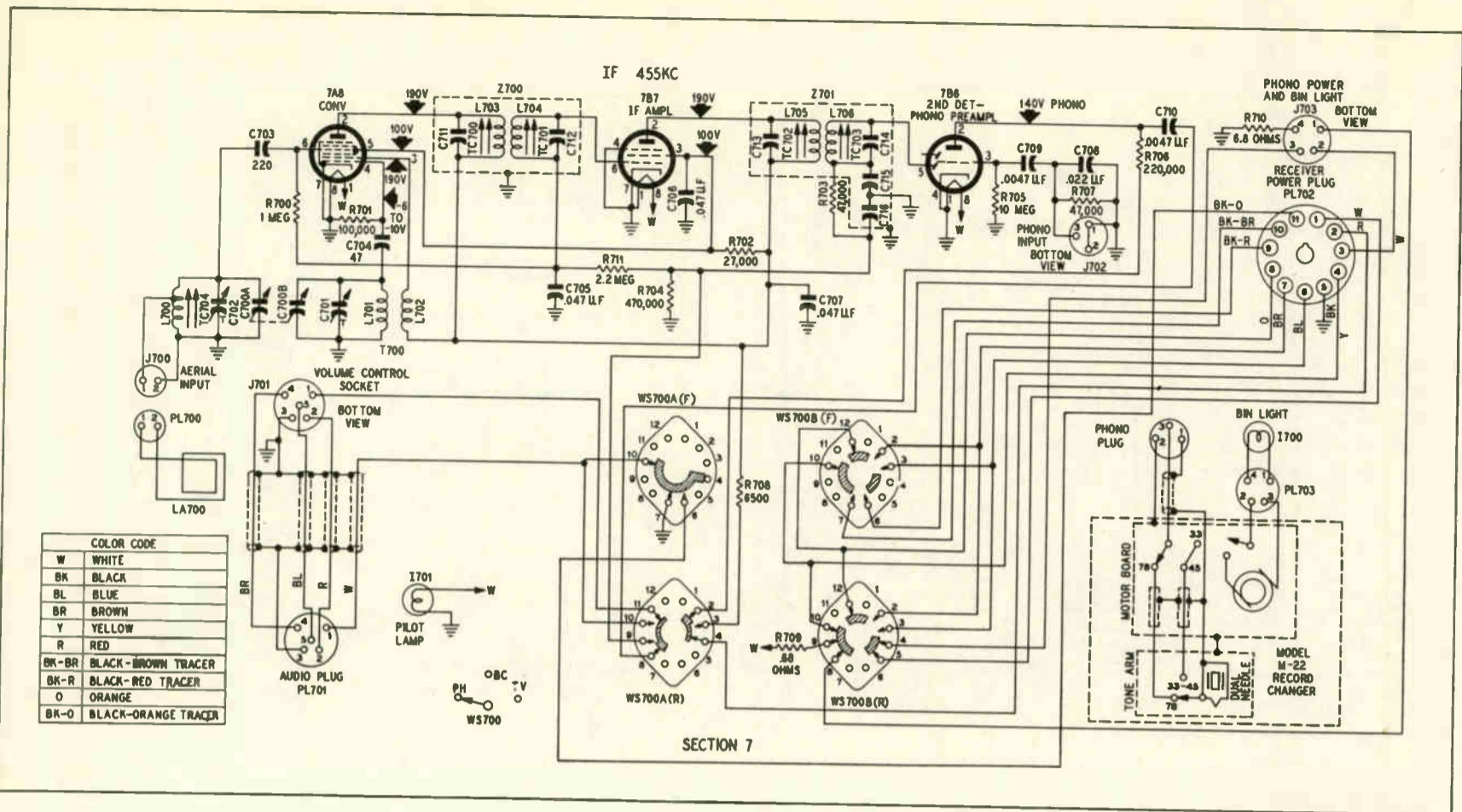
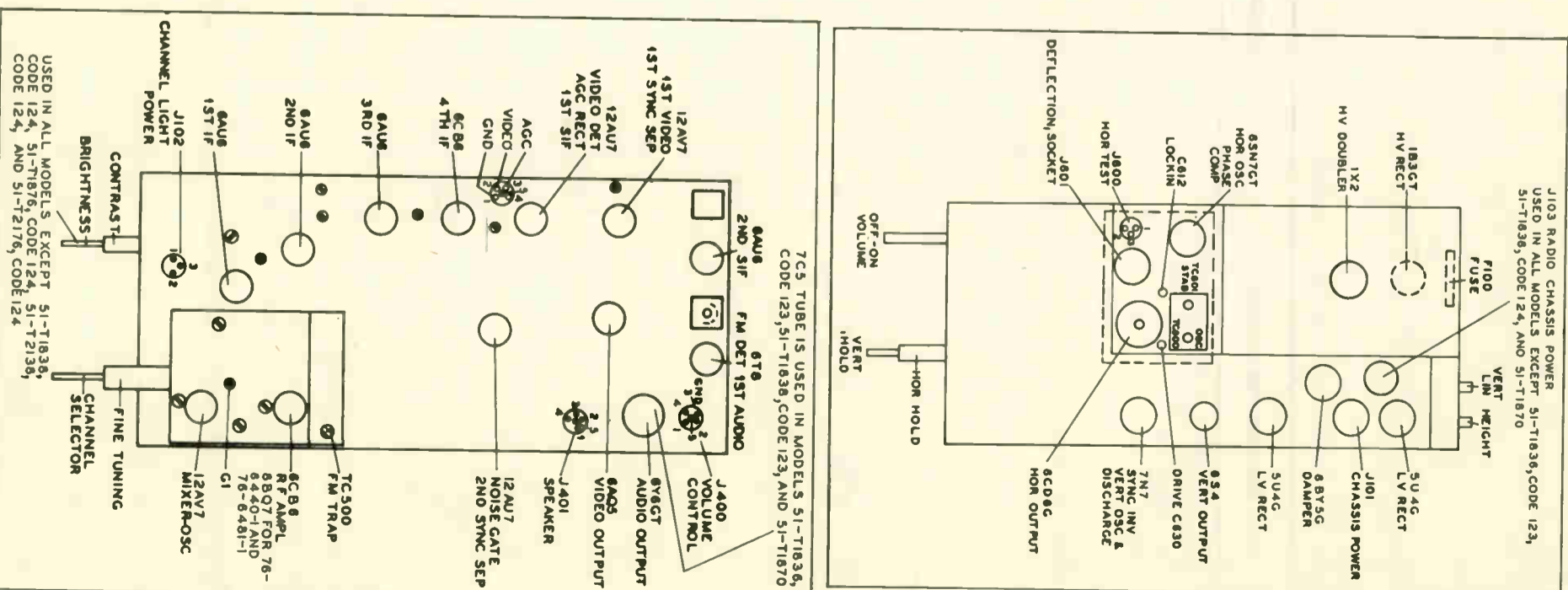
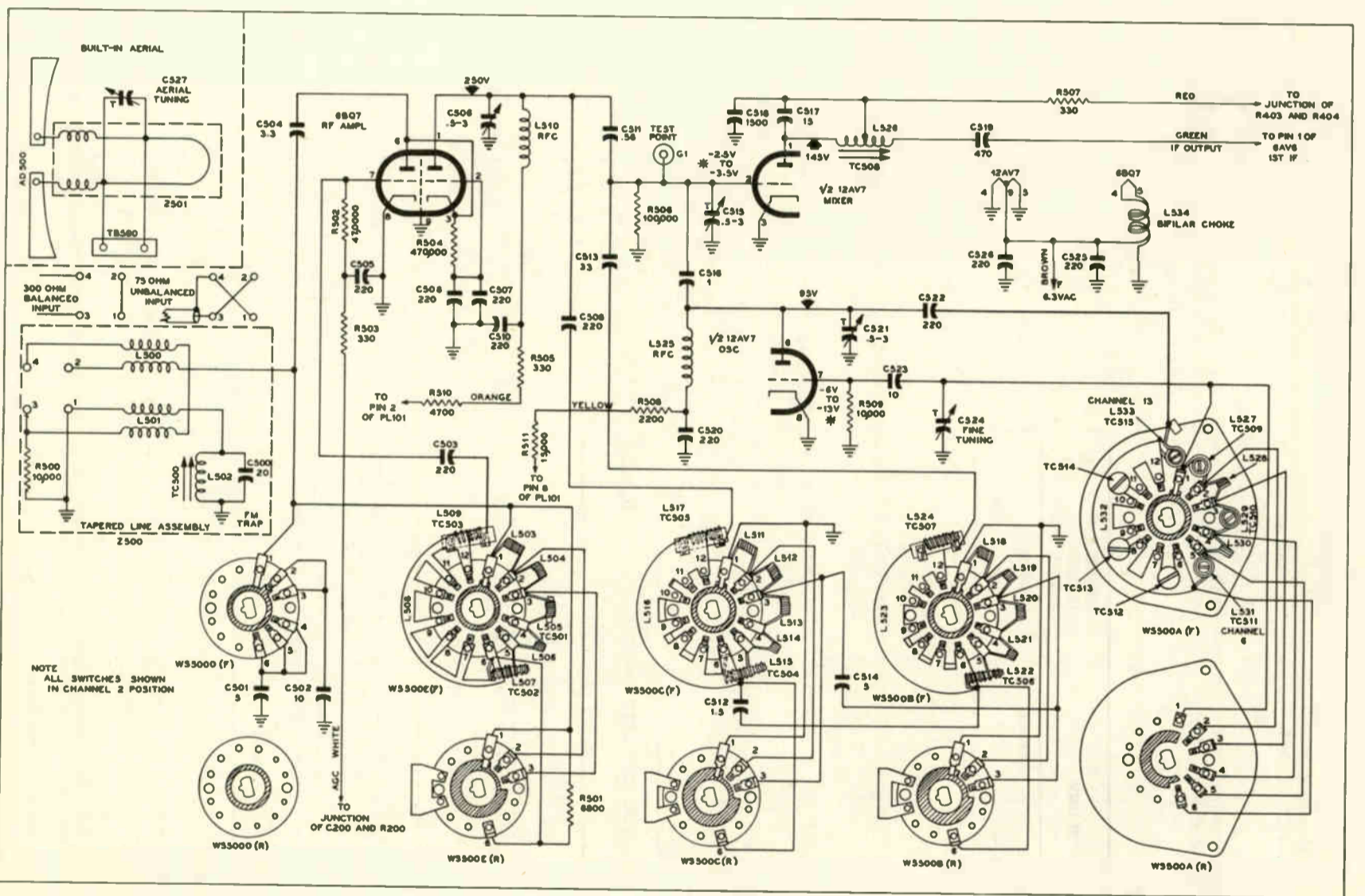

Figure 24. Schematic Diagram, Television Tuner Part No. 76-6481-1, Page 79 & 80 TPO-1794



J103 RADIO CHASSIS POWER  
USED IN ALL MODELS EXCEPT 51-T1836, CODE 124, 51-T1876, CODE 124, AND 51-T1870  
51-T1836, CODE 124, AND 51-T2136, CODE 124, AND 51-T2176, CODE 124



PRODUCTION CHANGES IN CP1 POWER CHASSIS Page 79

REASON FOR CHANGE	DESCRIPTION OF CHANGE	NEW OR ADDED PART NO.	OLD OR REMOVED PART NO.	RUN NO.
	Same as Run 7 of C1 chassis.			2
To reduce picture bounce.	a. R647 changed from 50,000 ohms to 18,000 ohms. b. R634 changed from 47,000 ohms to 82,000 ohms. c. R635 changed from 33,000 ohms to 47,000 ohms. d. 15,000-ohm resistor, in parallel with C102, removed. e. R107, 100,000 ohms, added, between R100 and pin 5 of J101. f. R108, 150,000 ohms, added, between pin 5 of J101 and ground. g. C629 changed from .1 $\mu$ f. to 10 $\mu$ f. h. R649, 100,000 ohms, removed. i. Same as Run 3 (both parts) of C3 chassis.	66-3184340 66-3824340 66-3478340  66-4108340 66-4158340 30-2417-19	66-4564340 66-3478340 66-3338340 66-3158340  45-3505-47 60-4108340	3

PRODUCTION CHANGES IN CP1 POWER CHASSIS Page 79

REASON FOR CHANGE	DESCRIPTION OF CHANGE	NEW OR ADDED PART NO.	OLD OR REMOVED PART NO.	RUN NO.
	Same as Run 8 of C1 chassis.			4
	Same as Run 6, a, of C3 chassis.			5
	Same as Run 5 of C3 chassis.			6
	Same as Run 10, a, of C1 chassis.			7
To limit voltage between earth and chassis ground.	100,000-ohm resistor added, between input side of S100 and ground.	66-4104340		
	High-voltage assembly changed.	76-6664	76-6500	8
	Same as Run 12 of C1 chassis.			9
	Same as Run 13 of C1 chassis.			10
To improve width of picture.	C634 changed from .001 $\mu$ f. to .0022 $\mu$ f.	30-4667-54	30-4650-52	11

PRODUCTION CHANGES IN CP1 DEFLECTION CHASSIS Page 79

REASON FOR CHANGE	DESCRIPTION OF CHANGE	NEW OR ADDED PART NO.	OLD OR REMOVED PART NO.	RUN NO.
To increase width of picture.	820- $\mu$ f. condenser added, across width coil.	60-10825011		13
To increase width of picture.	R643, screen dropping resistor, horiz. output tube, changed from 15,000 ohms, 5 watts, to 12,000 ohms, 5 watts. C634, width condenser, changed from .0022 $\mu$ f., 600V, to .0033 $\mu$ f., 600V.	33-1335-103 30-4650-55	33-1335-23 30-4650-54	14
To improve tone.	C416, d-c blocking condenser, changed from .01 $\mu$ f., 400V, to .0047 $\mu$ f., 600V.	30-4650-56	30-4650-41	
To improve range of HEIGHT control.	R618, sweep charging resistor, changed from 1.5 megohm to 1 megohm.	66-5108340	66-5158340	
To improve operation of vertical linearity control.	R622, vertical linearity control, changed from 5000 ohms to 2500 ohms. R623, vertical linearity limiting resistor, changed from 470 ohms to 820 ohms.	33-5546-40 66-1824346	33-5546-10 66-1474346	15
To eliminate vertical foldover.	R649, shaping resistor, changed from 100,000 ohms, 1 watt, to 180,000 ohms, 1 watt.	66-4184546		16

PRODUCTION CHANGES IN C2 DEFLECTION CHASSIS Page 81

REASON FOR CHANGE	DESCRIPTION OF CHANGE	NEW OR ADDED PART NO.	OLD OR REMOVED PART NO.	RUN NO.
To improve operation of vertical linearity control.	R622, vertical linearity control, changed from 5000 ohms to 2500 ohms. R623, vertical linearity limiting resistor, changed from 4700 ohms to 820 ohms.	33-5546-40 66-1824346	33-5546-10 66-2474346	5
To facilitate production.	R109, B plus dropping resistor, changed to new type resistor.	33-3347-3	33-3445-2	6
To increase height of picture.	Added R650, a 1.5-megohm resistor, from open end of R619, vertical height control, to ground.	66-5158546		7
To increase width of picture.	C634, width condenser, changed from .0033 $\mu$ f., 600V, to .0047 $\mu$ f., 1000V.	30-4650-90	30-4650-55	8
To protect power transformer.	A 5-ampere fuse was added, in series with J100, a-c power jack and S100, a-c power switch.	45-2656-25		9
To facilitate production.	R105 and R106, B plus voltage divider, changed to new type resistor.	33-3447-1	33-3445-4	17
To increase height of picture.	Added R650, a 1.5-megohm resistor, from open end of R619, vertical height control, to ground.	66-5158546		18
To increase width of picture.	C634, width condenser, changed from .0033 $\mu$ f., 600V, to .0047 $\mu$ f., 1000V.	30-4650-55	30-4650-55	19
To improve interlace	C704, vertical output loading condenser, changed from .0033 $\mu$ f. to .068 $\mu$ f.	30-4650-46	30-4668-38	10

PRODUCTION CHANGES IN 33 R-F CHASSIS Page 73

REASON FOR CHANGE	DESCRIPTION OF CHANGE	NEW OR ADDED PART NO.	OLD OR REMOVED PART NO.	RUN NO.
To facilitate production.	Removed R310, video output tube screen dropping resistor. Removed C308, B plus filter condenser. Changed C303, 4-section filter condenser.		66-3108340 30-2570-25 30-2570-70	8
To facilitate production.	Removed J102 and PL102, pilot-light jack and plug. Pilot light socket rewired to tie points on chassis.		27-8126 76-8184	9
To eliminate regeneration.	Red tuner lead moved from junction of R315, dropping resistor, and C303C, filter condenser, to terminal 2 of L203, second i-f coil.			10
To improve video amplifier response.	B5 wiring panel changed from 5-lug to 4-lug panel. Removed L302, series peaking coil, and R305, loading resistor, in first video amplifier plate circuit. Changed L303, peaking coil video output tube plate circuit, from 100 $\mu$ h. to a variable coil. Interchanged positions on schematic of R311, video output load resistor, and L303, video output peaking coil. R303, first video load resistor, changed from 2700 ohms to 3300 ohms. R600, R604, R605, C304, C306, C601, C602, and R306 repositioned on the chassis.		32-4480-8 66-3108340 32-4487-7 32-4480-3 66-2338346 66-2278346	11



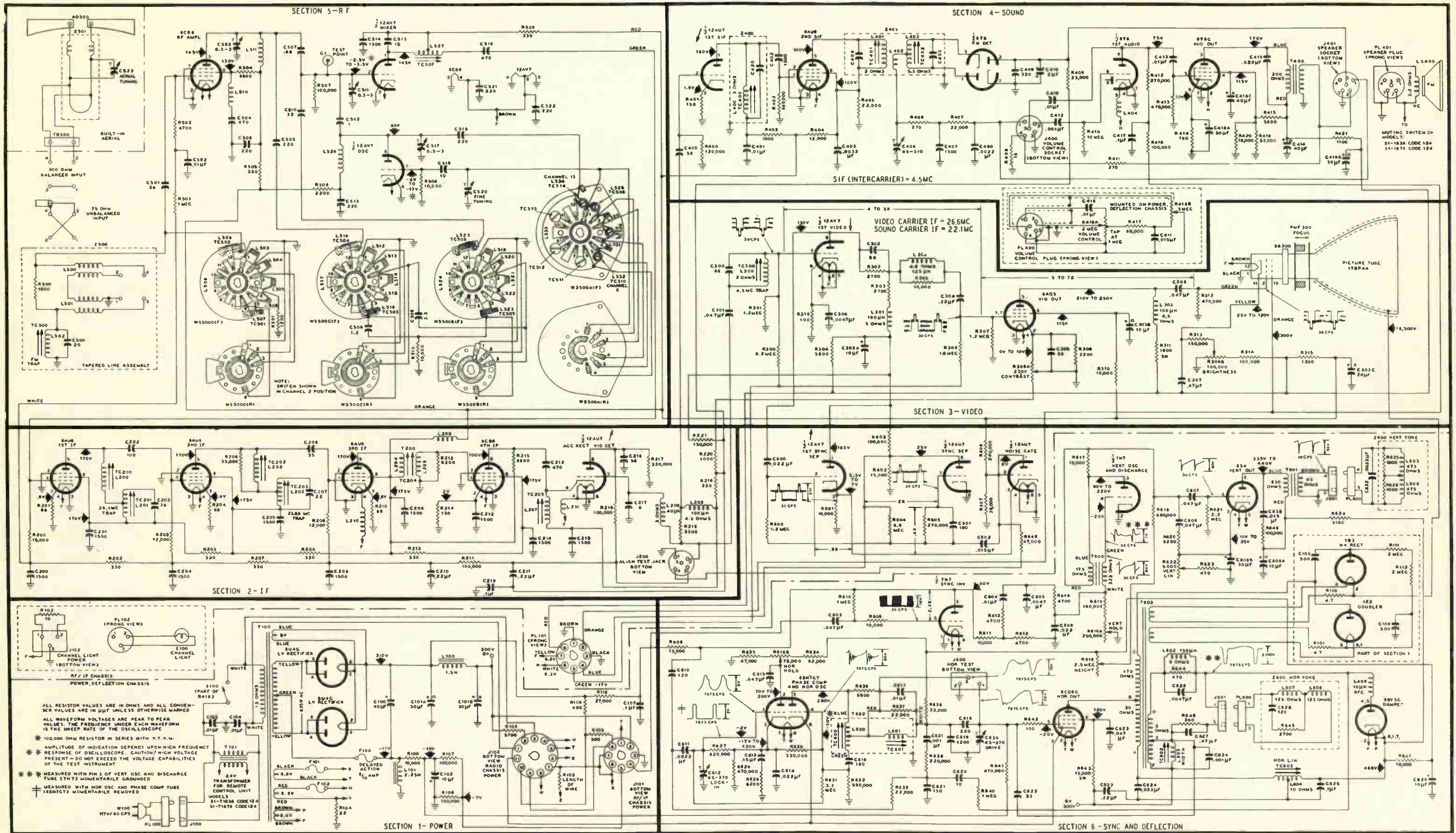

Television Schematic Diagram Models 51-T1833, CODE 121, 51-T1870, CODE 121, 51-T1871, CODE 121, 51-T1872, CODE 121, 51-T1874, CODE 121 51-T1875, CODE 121, 51-T1876, CODE 121, (Using 3P1 R-F Chassis and CP-1 Deflection Chassis.) 51-T1835, CODE 121, 51-T1838, CODE 124, (Using 3R2 R-F Chassis and CR-3 Deflection Chassis.) Power Chassis Tube Layout on page 85. RF Chassis Tube Layout on page 72. Production Changes on pages 68, 72 & 78. The Difference in 3P1 RF Chassis & 3R2 RF Chassis is the Tuner used. The 3P1 is used in the above Schematic. The 3R2 Tuner is on page 76. RT-4 Radio Tuner Schematic is on page 76. RT2. Radio Tuner Schematic is on page 41

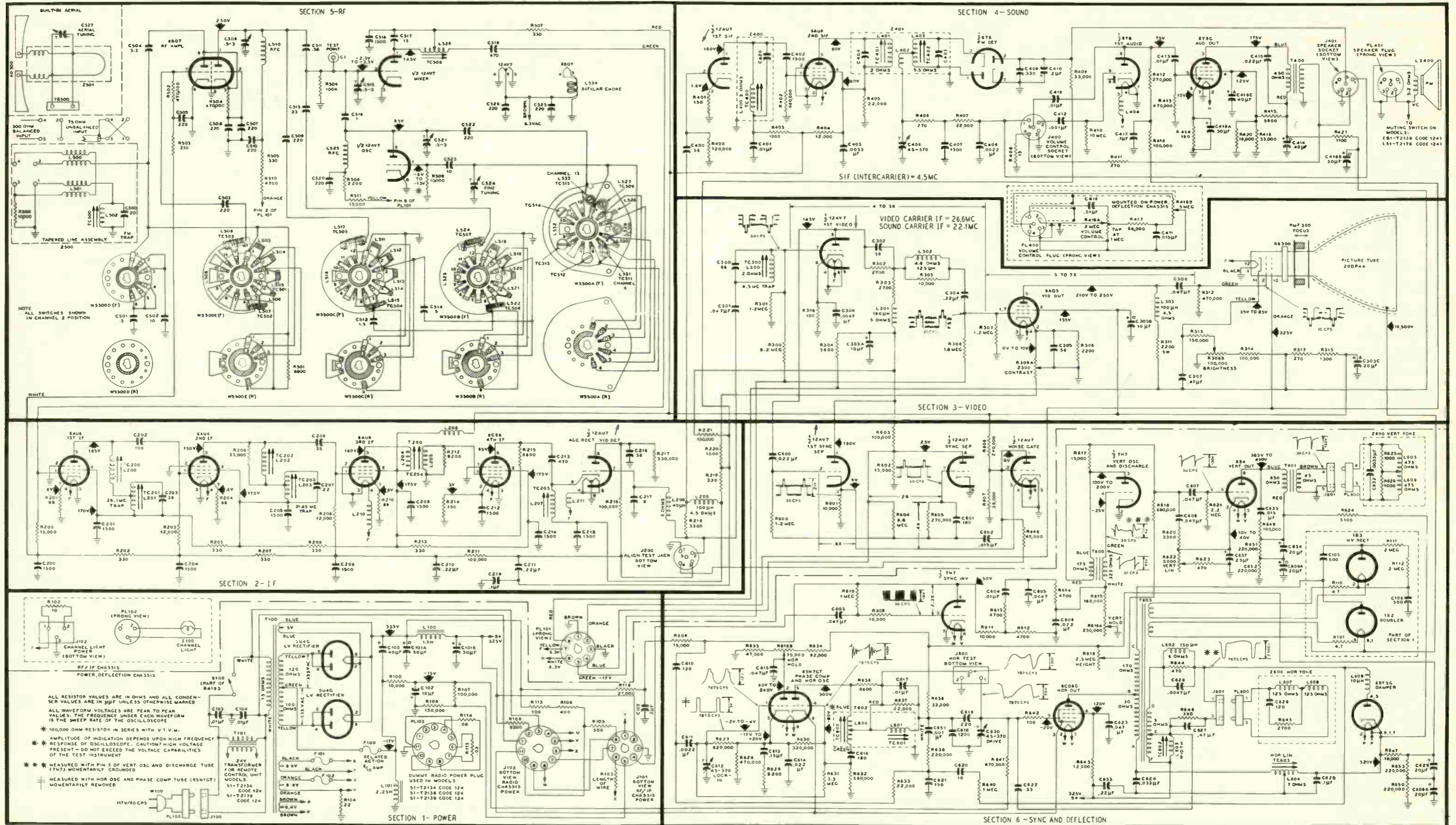

Television Schematic Diagram Models 51-T2102, CODE 121, 51-T2130, CODE 121, 51-T2132, CODE 121, 51-T2134, CODE 124, 51-T2136, CODE 124, Television - Radio - Phonograph Models 51-T2170, CODE 121, 51-T2175, CODE 121, All Using 35 R-F Chassis and F-2 Deflection Chassis. Radio Tuner RT2 is on page 41. Radio Tuner RT4 is on page 76. Television Schematic Diagram Models 51-T2133, CODE 121, 51-T2138, CODE 124, Television - Radio - Phonograph Remote Control Model 51-T2176, CODE 124, All Using 3R2 R-F Chassis and FR-2 Deflection Chassis.) Radio Tuner RT-2 (AM-FM) Production Changes on pages 86 & 88. RF Chassis Tube layout on page 85. Power Chassis Tube Layout on page 87. The Difference in the 35 RF Chassis & 3R2 RF Chassis is the Tuner used. The 35 RF Chassis is used in the above Schematic. The 3R2 RF Tuner is on page 76.

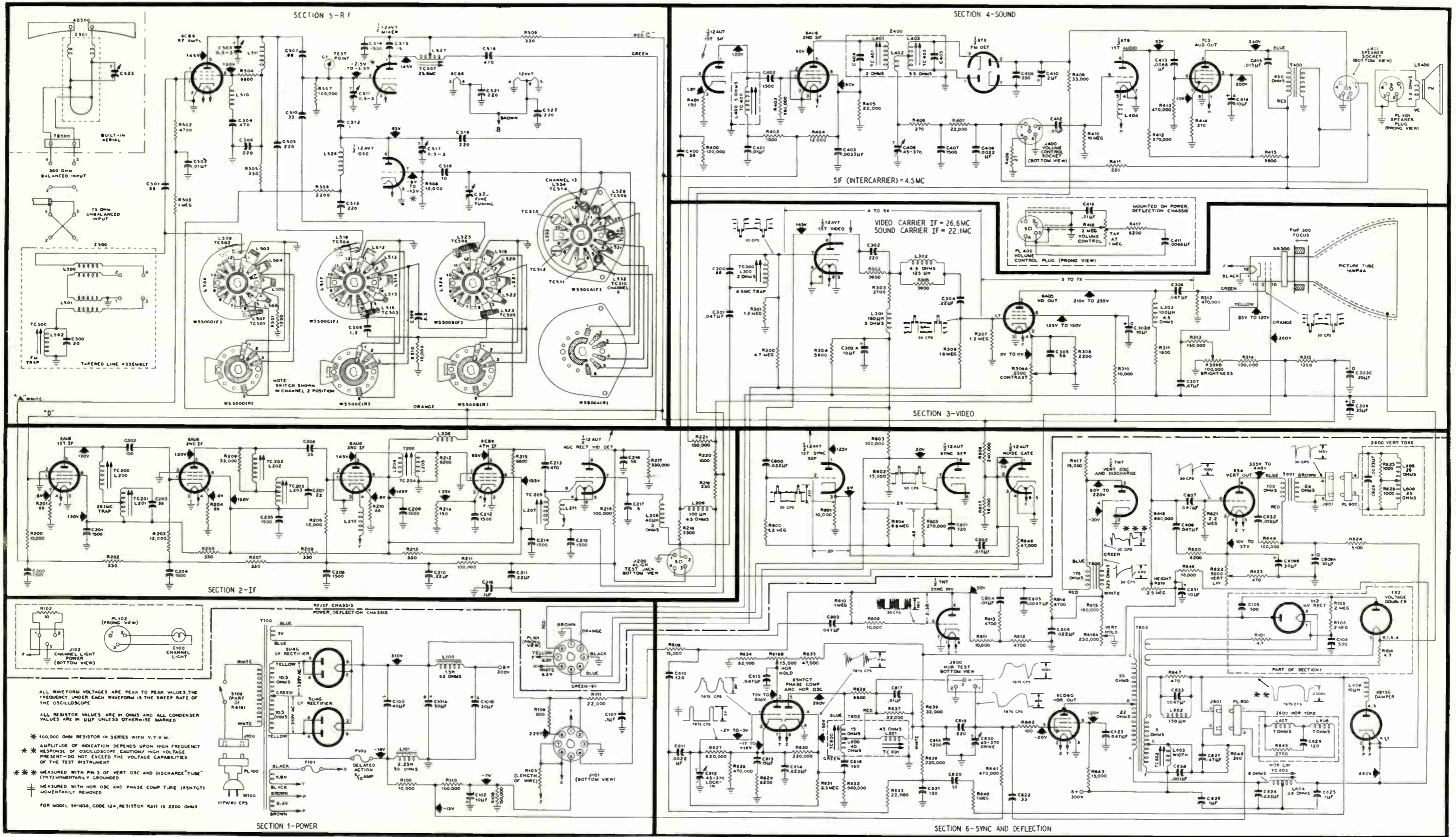

Television Schematic Diagram Models 51-T1800, CODE 122, (Using 32 R-F Chassis and C-2 Deflection Chassis.) 51-T1800, CODE 121, 51-T1830, CODE 121, 51-T1832, CODE 121, 51-T1834, CODE 121, 51-T1836, CODE 125, (Using 33 R-F Chassis and C-2 Deflection Chassis.) Production Changes on pages 72 & 78. RF Chassis Tube Layout 72. The Difference in the 33 RF Chassis & the 32 RF Chassis is the tuner. The 33 RF Chassis uses the above schematic. The 32 RF Tuner is on page 75.

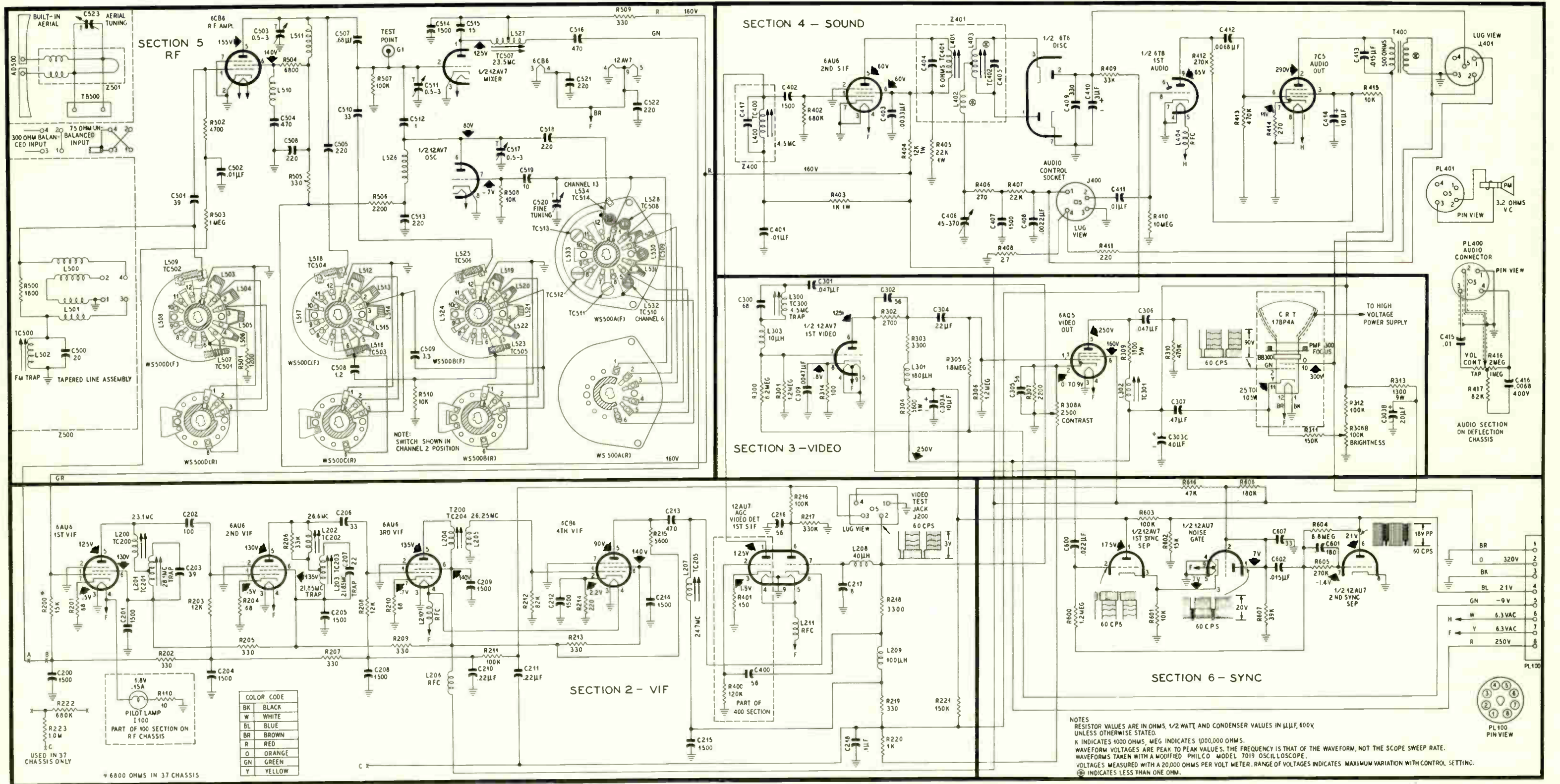

**R-F CHASSIS DIFFERENCES**

The 37 r-f chassis, as used in 1952 models, Code 123, is similar to the 33 chassis. The 33 chassis uses TV Tuner Part No. 76-5747, and the 37 chassis uses TV Tuner Part No. 76-6777-2. All other differences are shown on the schematic.

The 38 chassis, as used in 1952 models, Code 123, is similar to the 35 chassis. The 35 chassis uses TV Tuner Part No. 76-6440-1, and the 38 chassis uses TV Tuner Part No. 76-6777-2. Page 86

**Figure 14. Schematic Diagram of 33 R-F Chassis, Run 11, and 37 R-F Chassis, Run 1**

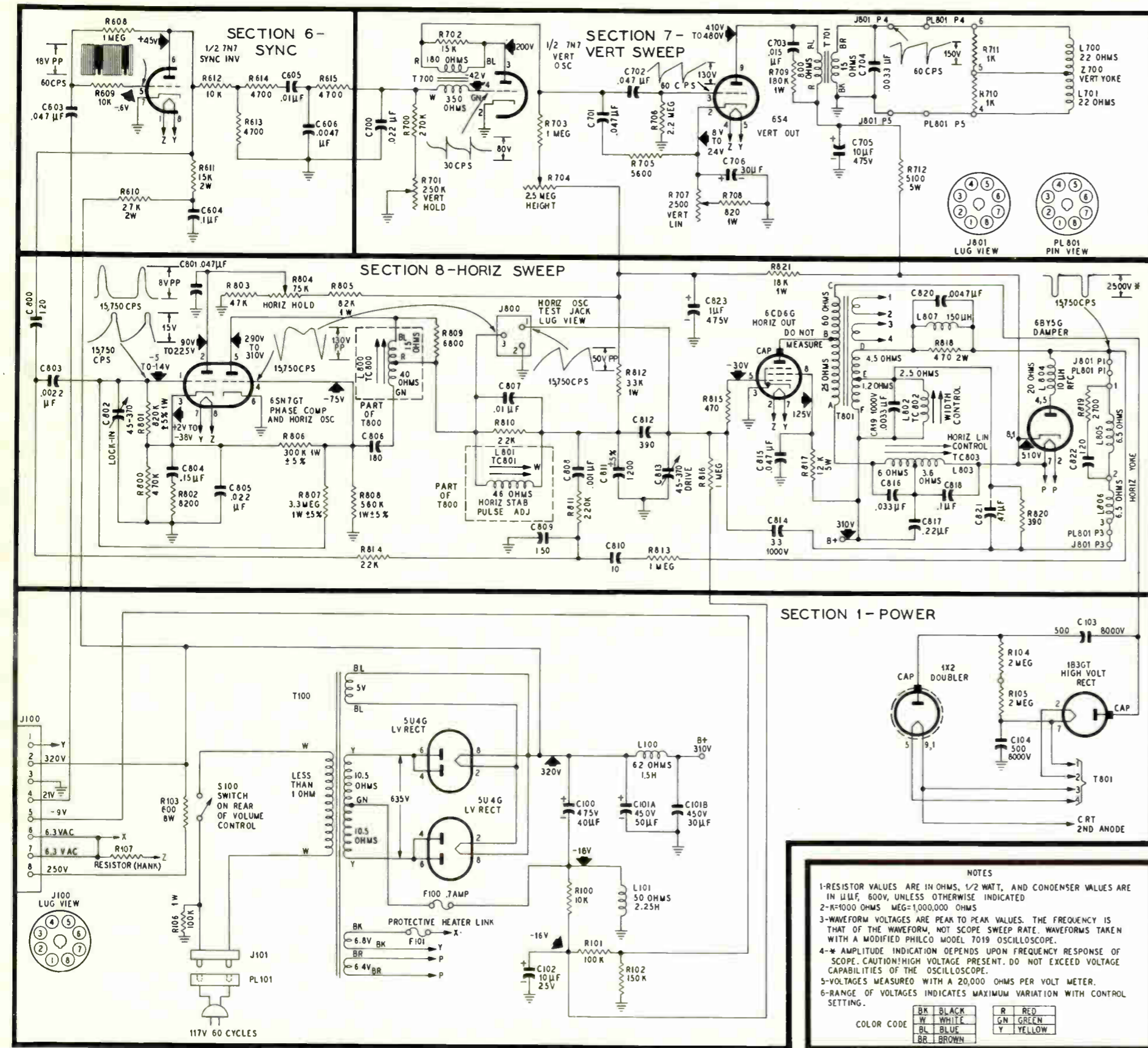
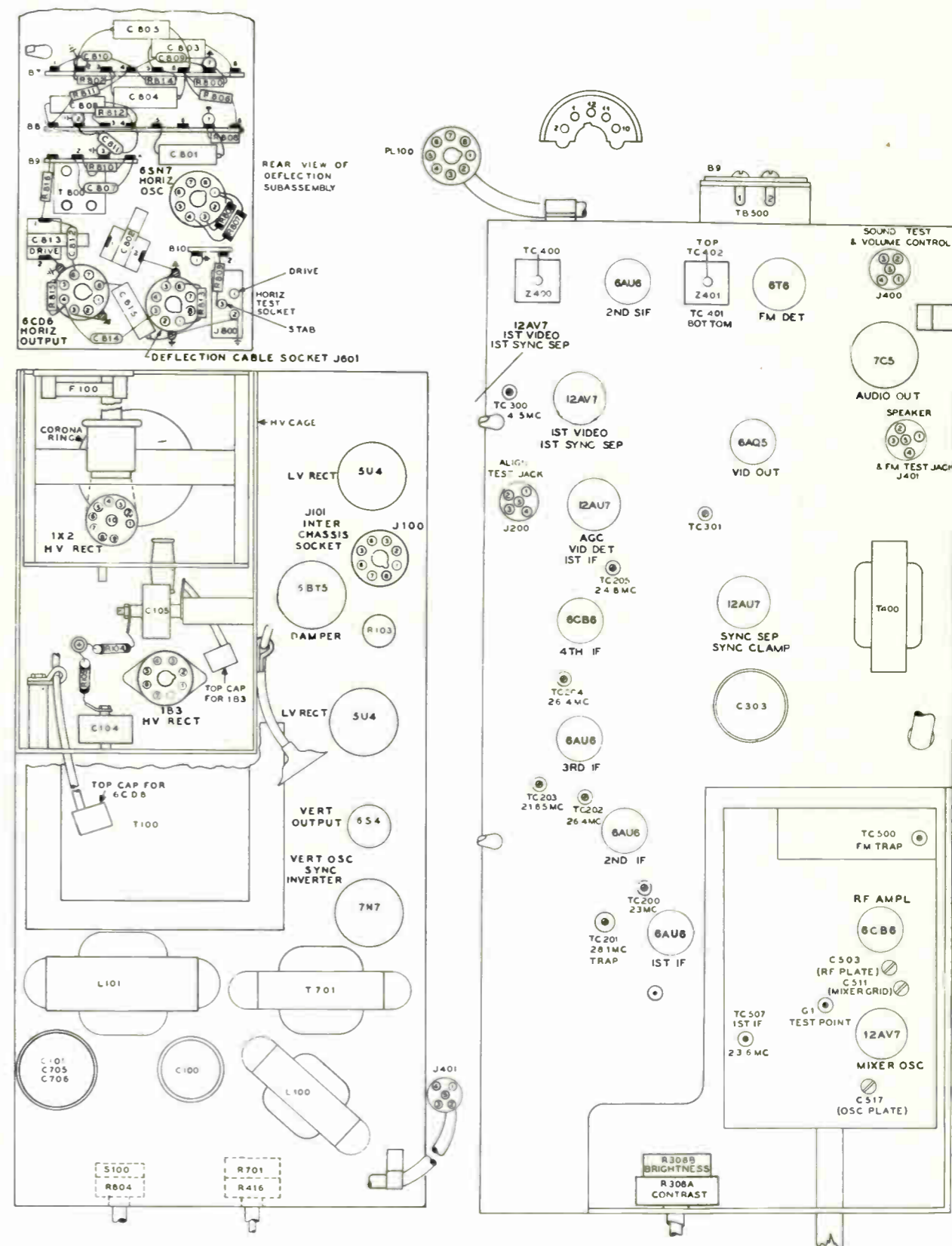
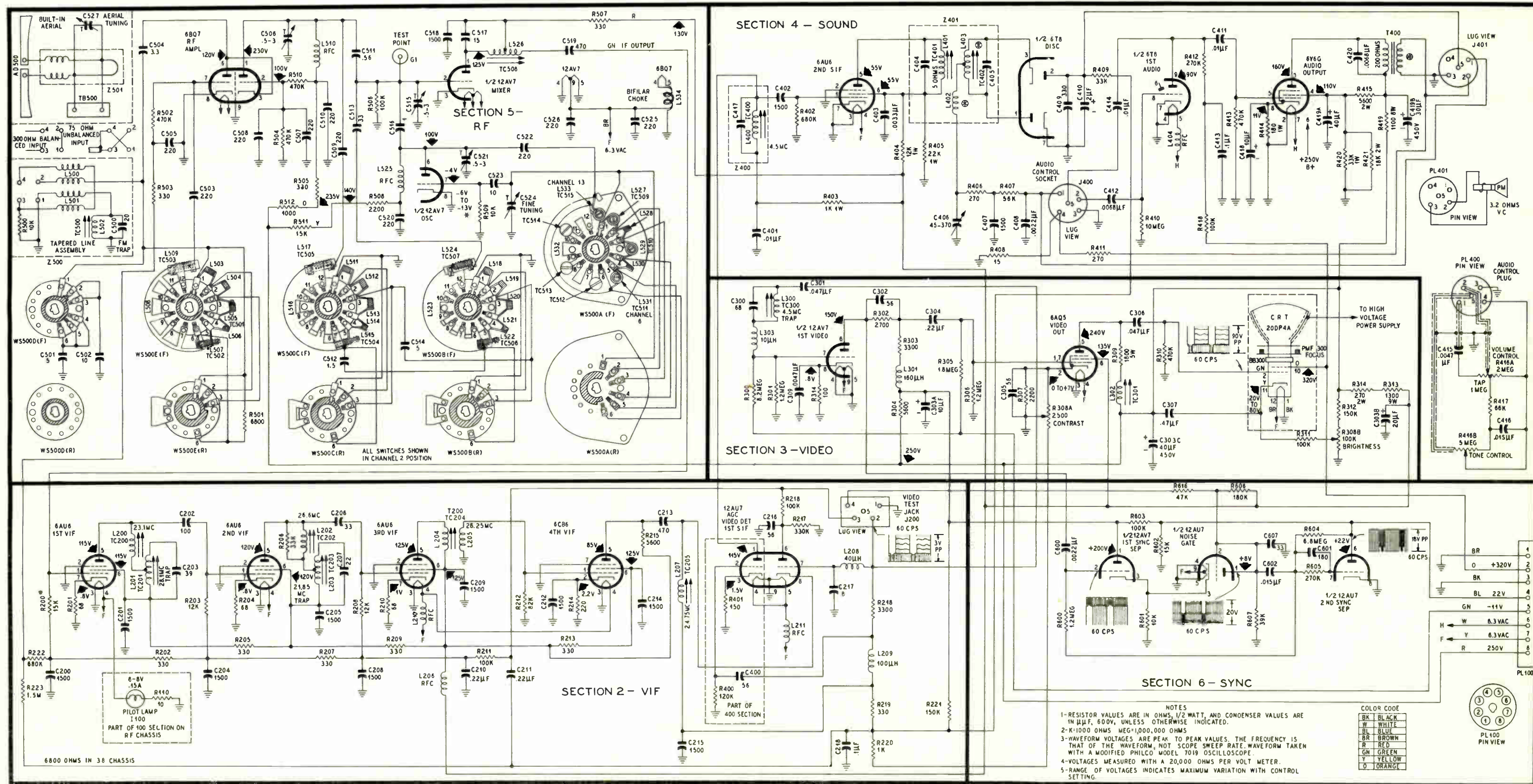

Figure 15. Schematic Diagram, C2 Deflection Chassis, Run 6



Base Layout, C2 Deflection Chassis, Run 6

Base Layout, 33 and 37 R-F Chassis Run 11



**R-F CHASSIS DIFFERENCES**

The 37 r-f chassis, as used in 1952 models, Code 123, is similar to the 33 chassis. The 33 chassis uses TV Tuner Part No. 76-5747, and the 37 chassis uses TV Tuner Part No. 76-6777-2. All other differences are shown on the schematic.

The 38 chassis, as used in 1952 models, Code 123, is similar to the 35 chassis. The 35 chassis uses TV Tuner Part No. 76-6440-1, and the 38 chassis uses TV Tuner Part No. 76-6777-2. Page 86

Figure 16. Schematic Diagram 35 and 38 R-F Chassis, Run 8

Television Schematic Diagram Models 51-T1871, CODE 122, 51-T1872, CODE 122, (Using 35 R-F Chassis and CP-1 Deflection Chassis.)



**PRODUCTION CHANGES IN F2 DEFLECTION CHASSIS** Page 80, 84, 87.

REASON FOR CHANGE	DESCRIPTION OF CHANGE	NEW OR ADDED PART NO.	OLD OR REMOVED PART NO.	RUN NO.
To improve interlace.	R620 changed from 8200 ohms to 5600 ohms. Converted Run 1 sets are designated by the letter "Z", following the run number.	66-2568340	66-2828340	2
To reduce high voltage.	R643 changed from 12,000 ohms to 15,000 ohms.  R618 changed from 1 megohm to 1.5 megohms. This resistor was listed as 680,000 ohms in Service Manual PR-1919. (See Run 7.)	33-1335-23  66-5158340	33-1335-103  66-5108340	3
To increase width.	C634 changed from .0033 $\mu$ f. to .0047 $\mu$ f. Converted sets of previous runs have .0022 $\mu$ f. shunting .0033 $\mu$ f., and are designated by the letter "W", following the run number. C634, omitted from the schematic diagram in Service Manual PR-1919, is connected in parallel with width coil L603.	45-3505-56	45-3505-52	4

REASON FOR CHANGE	DESCRIPTION OF CHANGE	NEW OR ADDED PART NO.	OLD OR REMOVED PART NO.	RUN NO.
To reduce ringing and high voltage.	C626 changed from .0047 $\mu$ f. to .0068 $\mu$ f., 400V.  L602 changed from 150 $\mu$ h. to 250 $\mu$ h.	45-3505-40  32-4480-4	45-3505-56  32-4480	5
To increase width.	C634 changed from .0047 $\mu$ f. to .0056 $\mu$ f.	45-3505-11	45-3505-56	6
To reduce high voltage.	R618 changed from 1.5 megohms to 1 megohm.	66-5108340	66-5158340	7
To facilitate production.	C627 changed from .47 $\mu$ f. to .22 $\mu$ f.	45-3505-32	45-3505-34	8
To facilitate production.	R106 and R113 replaced with one 500-ohm resistor.	33-3445-6	33-3445-4	9

REASON FOR CHANGE	DESCRIPTION OF CHANGE	NEW OR ADDED PART NO.	OLD OR REMOVED PART NO.	RUN NO.
To reduce hum.	T100, power transformer, shock mounted.			10
To facilitate production.	R650, R651, R652, R653, filter discharging resistors, changed from 220,000 ohms, 1 watt, to 330,000 ohms, $\frac{1}{2}$ watt.	66-4338340	66-4224346	11
To increase width of picture.	R643, screen dropping resistor, horiz. output, changed from 15,000 ohms, 5 watts, to 12,000 ohms, 10 watts.	33-1335-113	33-1335-106	12
To improve operation of vertical linearity control.	R622, vertical linearity control, changed from 5000 ohms to 2500 ohms.  R623, vertical linearity limiting resistor, changed from 4700 ohms to 820 ohms.	33-5546-40  66-1824346	33-5546-10  66-2474346	13
To facilitate production.	R105 and R106, voltage-divider resistors, changed to new type resistor.	33-3447-2	33-3445-8	14
To increase height of picture.	Added R650, a 1.5-megohm resistor, from open end of R619, vertical height control, to ground.	66-5158546		15
To protect power transformer.	5-ampere fuse added, in series with power-transformer primary.	45-2656-25		16
To improve interlace.	C632, vertical loading condenser, changed from .0033 $\mu$ f. to .068 $\mu$ f.	30-4650-46	30-4650-38	17

**PRODUCTION CHANGES IN FR2 POWER CHASSIS**

REASON FOR CHANGE	DESCRIPTION OF CHANGE	NEW OR ADDED PART NO.	OLD OR REMOVED PART NO.	RUN NO.
	Same as Run 5 of F2 chassis.			2
	Same as Run 6 of F2 chassis.			3

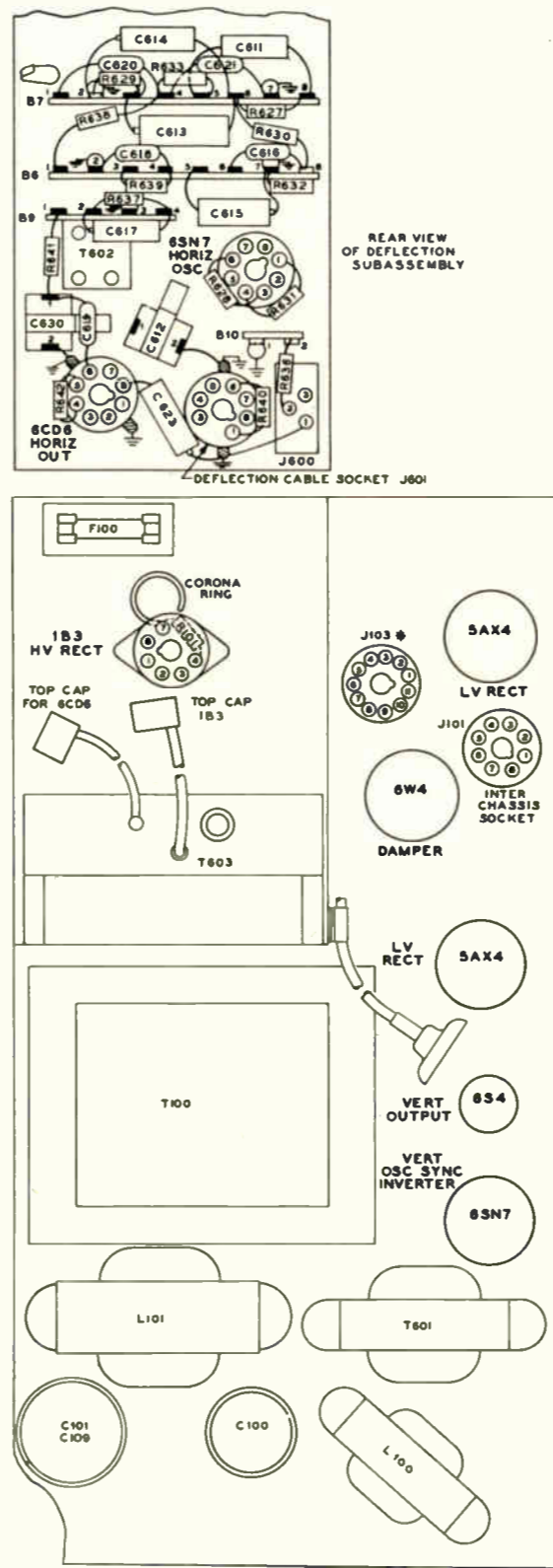

Figure 2. Base Layout for Power Chassis AP1, A1

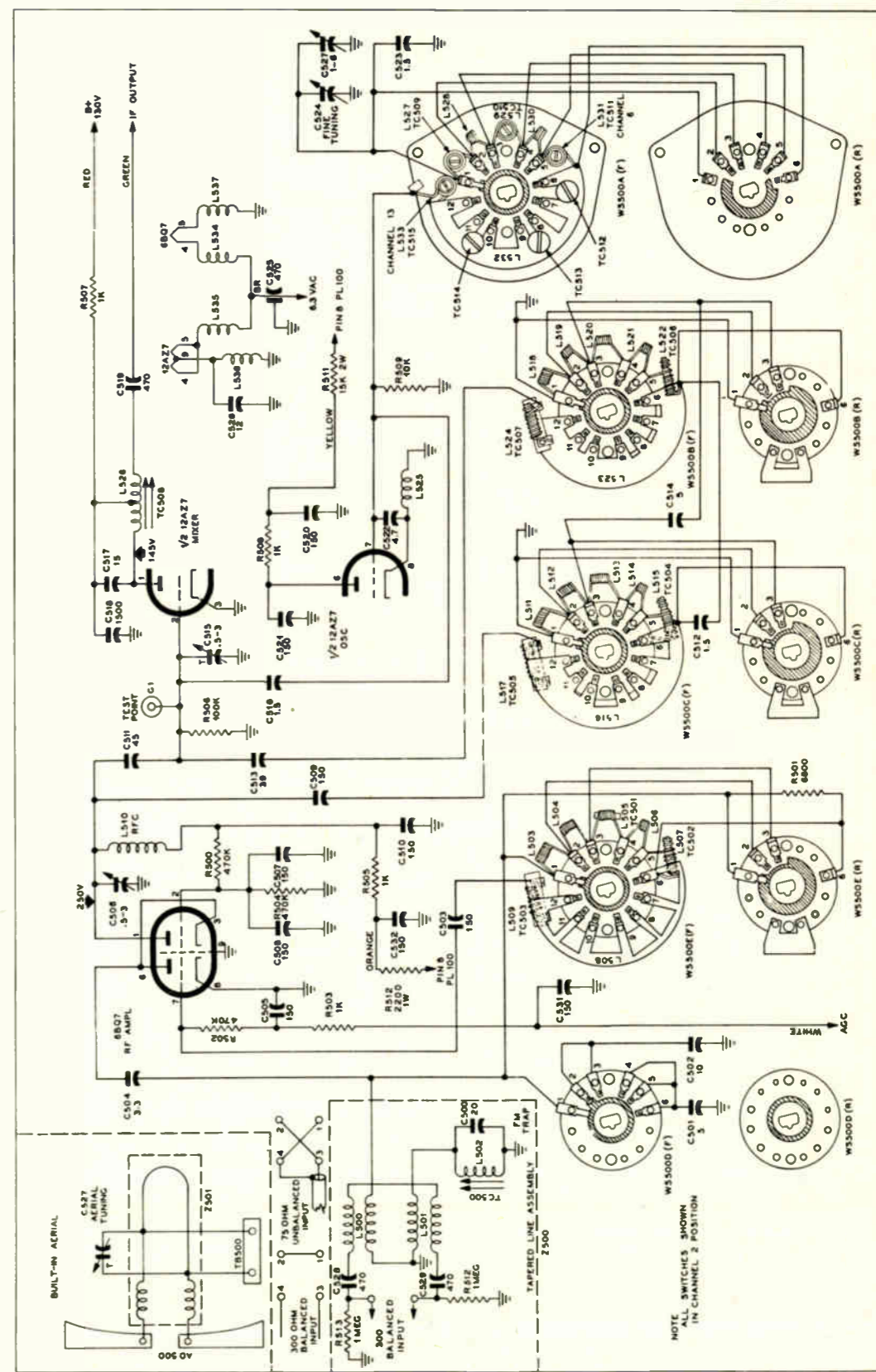

Figure 24. Schematic Diagram, TV Tuner Part No. 76-6777-2





**PRODUCTION CHANGES IN 35 R-F CHASSIS**

REASON FOR CHANGE	DESCRIPTION OF CHANGE	NEW OR ADDED PART NO.	OLD OR REMOVED PART NO.	RUN NO.
To improve sync performance in strong-signal areas.	R606, voltage divider of noise gate, changed from 240,000 ohms to 180,000 ohms.	66-4188240	66-4248240	5
To facilitate production.	Removed J102 and PL102, pilot-light jack and plug. Pilot-light socket wired to tie points on chassis.		27-6126 76-6184	6
To improve tuner (Part No. 78-6440-1) performance.	A 3-lug wiring panel was added. Reference symbol, B8A.			7
	680,000-ohm resistor added, in series with white tuner lead. Reference symbol, R222.	66-4688346		
	1.5-megohm resistor added, from junction of R222 and white lead of the tuner to junction of C211, C218, R219, and R220.	66-5158346		
	R510, B plus dropping resistor, changed from 1000 ohms to 2200 ohms.	66-2224546	66-2104346	
To improve video amplifier response.	B5 wiring panel changed from 5-lug to 4-lug panel.			8
	Removed L302, series peaking coil, and R305, loading resistor.		66-3108340 32-4480-8	
	L303, shunt peaking coil, changed from 100 $\mu$ h. to variable peaking coil.	32-4467-7	32-4480-3	
	R311, plate load resistor, second video amplifier, changed from 2200 ohms, 5 watts, to 1800 ohms, 5 watts.	33-1335-102	33-1335-97	
	R303, plate load resistor, first video amplifier, changed from 2700 ohms to 3300 ohms.	66-2338346	66-2278346	
R306, R600, R604, R605, C304, C306, C601, and C602 repositioned on the chassis.				
To eliminate regeneration.	Red tuner lead moved from junction of R315, dropping resistor, and C303C, filter condenser, to terminal 2 of L203, second i-f coil.			9
To eliminate audio oscillation.	100- $\mu$ l. condenser added, in parallel with R414, cathode bias resistor.	62-110409001		10
	An alternate change replaces R414 with a non-inductive carbon resistor.	66-1185356	66-1185340	
To improve operation at high signal levels.	Added a 40- $\mu$ h. choke, in parallel with R200, first video i-f grid-leak resistor.	32-4143-16		11
	R304, low-frequency compensating resistor, changed from 5600 ohms to 3900 ohms.	66-2395340	66-2564340	
	R300, grid bias divider resistor, first video amplifier, changed from 8.2 megohms to 1.2 megohms.	66-5128340	60-5828340	
	R301, grid-leak resistor, first video amplifier, changed from 1.2 megohms to 8.2 megohms.	66-5828340	60-5128340	

REASON FOR CHANGE	DESCRIPTION OF CHANGE	NEW OR ADDED PART NO.	OLD OR REMOVED PART NO.	RUN NO.
To improve picture quality.	R215 changed from 6800 ohms to 5600 ohms.	66-2568340	66-2688340	2
To reduce oscillator beat on Channel 5.	10- $\mu$ h. choke added, between L300 and pin 7 of first video amplifier.	32-4143-18		3
To improve sync performance.	R214 changed from 150 ohms to 220 ohms.	66-1224340	66-1154340	4

**PRODUCTION CHANGES IN 38 R-F CHASSIS**

REASON FOR CHANGE	DESCRIPTION OF CHANGE	NEW OR ADDED PART NO.	OLD OR REMOVED PART NO.	RUN NO.
To facilitate production.	C406, adjustable balancing condenser, changed to 390 $\mu$ l., fixed value.	60-10395417	31-6473-18	2

REASON FOR CHANGE	DESCRIPTION OF CHANGE	NEW OR ADDED PART NO.	OLD OR REMOVED PART NO.	RUN NO.
To facilitate production	R313, B plus dropping resistor, changed from 1300 ohms, 9 watts, to 1500 ohms, 12 watts.	33-3435-35	33-3435-31	3
	R314, B plus dropping resistor, removed.		66-1278340	
	R304, low-frequency compensating resistor, changed from 3900 ohms, 2 watts, to 5600 ohms, 1 watt.	66-2564340	66-2395340	

**PRODUCTION CHANGES IN 37 R-F CHASSIS**

REASON FOR CHANGE	DESCRIPTION OF CHANGE	NEW OR ADDED PART NO.	OLD OR REMOVED PART NO.	RUN NO.
To facilitate production	R313, B plus dropping resistor, changed from 1300 ohms, 9 watts, to 1500 ohms, 12 watts.	33-3435-35	33-3435-31	5
	R304, low-frequency compensating resistor changed from 3900 ohms, 2 watts, to 5600 ohms, 1 watt.	66-2564340	66-2395340	

REASON FOR CHANGE	DESCRIPTION OF CHANGE	NEW OR ADDED PART NO.	OLD OR REMOVED PART NO.	RUN NO.
	R223, a-g-c delay resistor, changed from 1.5 megohms to 3.3 megohms.	66-5338340	66-5158340	2
To improve operation at high signal levels.	Added a 40- $\mu$ h. choke, in parallel with R200, first video i-f grid leak.	32-4143-16		3
	R304, low-frequency compensating resistor, changed from 5600 ohms to 3900 ohms.	66-2395340	66-2564340	
	R300, grid bias divider resistor, first video amplifier, changed from 8.2 megohms to 1.2 megohms.	66-5128340	66-5828340	
	R301, grid-leak resistor, first video amplifier, changed from 1.2 megohms to 8.2 megohms.	66-5828340	60-5128340	
To facilitate production.	C406, adjustable balancing condenser, changed to 390 $\mu$ l., fixed value.	60-10395417	31-6473-18	4

**CHANGES IN CP1 DEFLECTION CHASSIS (Cont.)**

REASON FOR CHANGE	DESCRIPTION OF CHANGE	NEW OR ADDED PART NO.	OLD OR REMOVED PART NO.	RUN NO.
To facilitate production.	R105 and R106, B plus voltage divider, changed to new type resistor.	33-3447-1	33-3445-4	17
To increase height of picture.	Added R650, a 1.5-megohm resistor, from open end of R619, vertical height control, to ground.	66-5158546		18

**PRODUCTION CHANGES IN 41 R-F CHASSIS**

REASON FOR CHANGE	DESCRIPTION OF CHANGE	NEW OR ADDED PART NO.	OLD OR REMOVED PART NO.	RUN NO.
To provide for vertical retrace suppression.	A lead was added in the chassis interconnecting cable (pin 10 of PL100 to the picture-tube cathode).	41-4086-19	41-4086-1	9
To facilitate production.	C406, ratio detector buzz by-pass condenser, was changed from 390 $\mu\text{f.}$ , mica, to 330 $\mu\text{f.}$ , ceramic type.	62-133001001	60-10395417	10
To improve picture-tube cutoff.	R314, picture-tube cathode resistor, was changed from 82K, $\frac{1}{2}$ w., to 68K, 1 w. R313, picture-tube cathode resistor, was changed from 120K, $\frac{1}{2}$ w., to 100K, $\frac{1}{2}$ w.	66-3684340 66-4108340	66-3828340 66-4128340	11
To improve strong-signal low percentage sync performance.	Noise-gate divider resistor, R606, was changed from 240K to 180K. Noise-gate divider resistor, R607, was changed from 220K to 39K.	66-4188240 66-3398240	66-4248240 66-4228240	12

REASON FOR CHANGE	DESCRIPTION OF CHANGE	NEW OR ADDED PART NO.	OLD OR REMOVED PART NO.	RUN NO.
To eliminate picture washout	R419, B plus dropping resistor, changed from 1550 ohms, 11 watts, to 1500 ohms, 12 watts.	33-3435-35	33-3435-34	5
	R304, low-frequency compensating resistor, changed from 3900 ohms, 2 watts, to 5600 ohms, 1 watt.	66-2564340	66-2395340	
To center range of variable peaking coil	L302, first-video-amplifier shunt peaking coil, changed from 220 $\mu\text{h.}$ to 180 $\mu\text{h.}$	32-4480-9	32-4480-15	6
	C308, first-video-amplifier cathode by-pass condenser, changed from .0047 $\mu\text{f.}$ to .0033 $\mu\text{f.}$	30-4650-38	30-4650-56	
To improve performance in noisy signal areas	R604, voltage divider in plate of second sync separator, changed from 1 megohm to 1.2 megohms.	66-5128340	66-5108340	7
To eliminate shock hazard	Two 470- $\mu\text{f.}$ condensers added in series with aerial leads on tapered-line assembly, Z500 (shown as C528 and C529 in figure 37 of PR-1941).	62-147001001		8
	Two 1-megohm resistors added from aerial leads to chassis (shown as R512 and R513 in figure 37 of PR-1941).	66-5108340		
To facilitate production	C406, adjustable balancing condenser, changed to 390 $\mu\text{f.}$ , fixed value.	60-10395417	31-6473-18	2
To improve tone	C414, plate by-pass condenser, changed from .015 $\mu\text{f.}$ to .01 $\mu\text{f.}$	3-4650-92	30-4650-93	3
To facilitate production	R419, B plus dropping resistor, changed from two components in series (1300 ohms, 9 watts, and 270 ohms, 2 watts), to one 1550 ohm, 11 watt resistor.	33-3435-34	33-3435-31 66-1275340	
To improve sync performance	R601, first-sync-separator cathode resistor, changed from 10,000 ohms to 4700 ohms.	66-2478340	66-3108340	4
	R604, second-sync-separator divider resistor, changed from 1.2 megohms to 1 megohm.	66-5108340	66-5128340	
	R606, noise-gate voltage divider, changed from 180,000 ohms to 240,000 ohms.	66-4248340	66-4188340	
	R608, video-test-jack isolating resistor changed from 47,000 ohms to 220,000 ohms.	66-4228340	66-3478340	
	C603, noise-gate by-pass moved from plate of noise gate to plate of second sync separator and junction of R604 and R605.			

**PRODUCTION CHANGES IN D-1 AND D-1A DEFLECTION CHASSIS**

REASON FOR CHANGE	DESCRIPTION OF CHANGE	NEW OR ADDED PART NO.	OLD OR REMOVED PART NO.	RUN NO.
To improve tone	C412, tone compensation condenser, changed from .0068 $\mu\text{f.}$ to .01 $\mu\text{f.}$	30-4668-41	30-4668-40	2
To facilitate production	High-voltage assembly changed. The deflection socket was rewired in this change, and the chassis designation was changed to D-1A. See run 2 of high-voltage assembly, Part No. 76-6850.	High-voltage assembly 76-6850, Run 2	High-voltage assembly 76-6850	3
To increase width	R816, horizontal-output screen dropping resistor, changed from 6500 ohms, 5 watts, to 5100 ohms, 5 watts.	33-1335-18	33-1335-19	4
To facilitate production	T800, horizontal-oscillator transformer, changed.	32-8551	32-8517	5
To improve tone	C412, tone compensating condenser, changed from .01 $\mu\text{f.}$ to .0068 $\mu\text{f.}$	30-4668-40	30-4668-41	6
To prevent parasitic oscillation	330-ohm resistor added in series with grid of vertical-output tube (6EG6GT).	66-1338340		7
To eliminate vertical-output-transformer buzz	R703, vertical step resistor, moved across secondary of vertical output transformer, C701. Vertical charging condenser grounded to chassis.			8

REASON FOR CHANGE	DESCRIPTION OF CHANGE	NEW OR ADDED PART NO.	OLD OR REMOVED PART NO.	RUN NO.
To improve horizontal sync performance.	Horizontal oscillator grid blocking condenser, C808, was reconnected between the green lead from T800 and pin 4 of the horizontal oscillator tube. The white lead from T800 is now grounded.	—	—	9
To provide for vertical retrace suppression.	High-voltage ass'y. was changed.	76-6850 Run 4	76-6850 Run 3	10
	A .022- $\mu\text{f.}$ condenser was added, from pin 11 of J800 to pin 10 of J100.	30-4650-43	—	

REASON FOR CHANGE	DESCRIPTION OF CHANGE	NEW OR ADDED PART NO.	OLD OR REMOVED PART NO.	RUN NO.
To facilitate production.	Value of current-limiting resistor, R102, was changed from 7.5 ohms, 15 w., to 5 ohms, 16 w.	33-3448-5	32-3448	11
To improve horizontal-oscillator performance and recenter horizontal-oscillator frequency control.	Value of horizontal phase comparator voltage-divider resistor, R809, was changed from 390K to 330K. Value of horizontal-oscillator grid blocking condenser, C808, was changed from 270 $\mu\text{f.}$ to 390 $\mu\text{f.}$	66-4338240 60-10395417	66-4395244 60-10275337	12
To eliminate hum pickup from the a-c leads.	The horizontal lockin trimmer, C804, was relocated, from the rear to the side of the chassis.	—	—	13















**PRODUCTION CHANGES IN 44 R-F CHASSIS**

REASON FOR CHANGE	DESCRIPTION OF CHANGE	NEW OR ADDED PART NO.	OLD OR REMOVED PART NO.	RUN NO.
To improve sync performance	R601, first-sync-separator cathode resistor, changed from 10,000 ohms to 4700 ohms.	66-2478340	66-3108340	3
	R604, second-sync-separator divider resistor, changed from 1.2 megohms to 1 megohm.	66-5108340	66-5128340	
	R606, noise-gate voltage divider, changed from 180,000 ohms to 240,000 ohms.	66-4248340	66-4188340	
	R608, video-test-jack isolating resistor, changed from 47,000 ohms to 220,000 ohms.	66-4248340	66-4188340	
	C603, noise-gate by-pass moved from plate of noise gate to plate of second sync separator and junction of R604 and R605.			
To facilitate production	R419, B plus dropping resistor, changed from 1550 ohms, 11 watts, to 1500 ohms, 12 watts.	33-3435-35	33-3535-34	
To improve performance in noisy signal areas	R604, second-sync-separator voltage divider, changed from 1 megohm to 1.2 megohms.	66-5128340	66-5108340	4
To center range of variable peaking coil	L302, first-video-amplifier shunt peaking coil, changed from 220 $\mu$ h. to 180 $\mu$ h.	32-4480-9	32-4480-15	
	C308, first-video-amplifier cathode by-pass condenser changed from .0047 $\mu$ f. to .0033 $\mu$ f.	30-4650-38	30-4650-56	
To eliminate shock hazard	Two 470- $\mu$ f. condensers added in series with aerial leads of tapered-line assembly, Z500 (shown as C528 and C529 in figure 41 of PR-1941).	62-147001001		4

REASON FOR CHANGE	DESCRIPTION OF CHANGE	NEW OR ADDED PART NO.	OLD OR REMOVED PART NO.	RUN NO.
	Two 1-megohm resistors added from aerial terminals to chassis (shown as R512 and R513 in figure 41 of PR-1941).	66-5108340		4 (Cont.)

REASON FOR CHANGE	DESCRIPTION OF CHANGE	NEW OR ADDED PART NO.	OLD OR REMOVED PART NO.	RUN NO.
To facilitate production.	R419A and R419B, B plus dropping resistors, changed from two resistors of 270 ohms and 1300 ohms to one resistor, R419, 1550 ohms.	33-3435-34	66-1275346 33-3435-31	2

REASON FOR CHANGE	DESCRIPTION OF CHANGE	NEW OR ADDED PART NO.	OLD OR REMOVED PART NO.	RUN NO.
To provide for vertical retrace suppression.	A lead was added in the chassis interconnecting cable (pin 10 of PL100 to the picture-tube cathode).	—	—	5
To facilitate production.	C406, ratio detector buzz by-pass condenser, was changed from 390 $\mu$ f., mica, to 330 $\mu$ f., ceramic type.	62-133001001	60-10395417	
To improve picture-tube cutoff.	R314, picture-tube cathode resistor, was changed from 82K, 1/2 w., to 68K, 1 w. R313, picture-tube cathode resistor, was changed from 120K, 1/2 w., to 100K, 1/2 w.	66-3684340 66-4108340	66-3828340 66-4128340	
To improve strong-signal low percentage sync performance.	Noise-gate divider resistor, R606, was changed from 240K to 180K. Noise-gate divider resistor, R607, was changed from 220K to 39K.	66-4188340 66-3398340	66-4248340 66-4228340	6

**PRODUCTION CHANGES IN 42 R-F CHASSIS**

REASON FOR CHANGE	DESCRIPTION OF CHANGE	NEW OR ADDED PART NO.	OLD OR REMOVED PART NO.	RUN NO.
To improve strong-signal low percentage sync performance.	Noise-gate divider resistor, R606, was changed from 240K to 180K. Noise-gate divider resistor, R607, was changed from 220K to 39K.	66-4188240 66-3398240	66-4248240 66-4228240	2

**PRODUCTION CHANGES IN D-4 AND D-4A DEFLECTION CHASSIS**

REASON FOR CHANGE	DESCRIPTION OF CHANGE	NEW OR ADDED PART NO.	OLD OR REMOVED PART NO.	RUN NO.
To facilitate production	T800, horizontal oscillator transformer, changed.	32-8551	32-8517	2
	High-voltage assembly changed. The deflection socket was rewired in this change, and the chassis designation was changed to D-4A. See Run 2 of high-voltage assembly, Part No. 76-6850.	High-voltage assembly 76-6850 Run 2	High-voltage assembly 76-6850	
To prevent parasitic oscillation	330-ohm resistor added in series with grid of vertical-output tube (6BQ6GT).	66-1338340		3
To improve performance	R103, filament dropping resistor, changed from .24 ohm, 2 watts, to .24 ohm, 5 watts.	33-3448-17	66-8245340	
To eliminate vertical output transformer buzz	R703, vertical step resistor, moved across secondary of vertical output transformer. C701, vertical charging condenser, grounded to chassis.			

**PRODUCTION CHANGES IN G-2 DEFLECTION CHASSIS**

REASON FOR CHANGE	DESCRIPTION OF CHANGE	NEW OR ADDED PART NO.	OLD OR REMOVED PART NO.	RUN NO.
To remove vertical white lines from picture.	220K resistor, R814, was removed. Value of R803 was changed from 2.2 megohms to 680K.	66-4683346 66-4688340	66-4228346 66-5228340	2

## SERVICE HINTS

### LONG WARM-UP TIME OF MODELS USING H-1 AND H-4 DEFLECTION CHASSIS

In receivers equipped with an H-1 or H-4 deflection chassis, the average warm-up time considered to be normal, with 117-volt, a-c input, is 30 seconds. Longer warm-up periods may be caused by a slow-heating damper tube (6AX4GT). In a few cases long warm-up time of the horizontal output tube (6BQ6GT) in addition to that of the damper tube may be the cause. In such cases, first replace the 6AX4GT tube and check the warm-up time; if still too long, replace the 6BQ6GT tube also.

### SHORTING PLUG TO PERMIT OPERATION OF COMBINATION MODELS USING 84 OR 94 R-F CHASSIS, WITHOUT RADIO SECTION

Receivers incorporating either the 84 R-F, or 94 R-F chassis, may be operated independently of the radio section by using a shorting plug in place of the radio section power-connecting plug (PL102). This service aid may be fabricated from a male plug, Part No. 54-4875-4, by wiring between the pins as shown in figure 2.

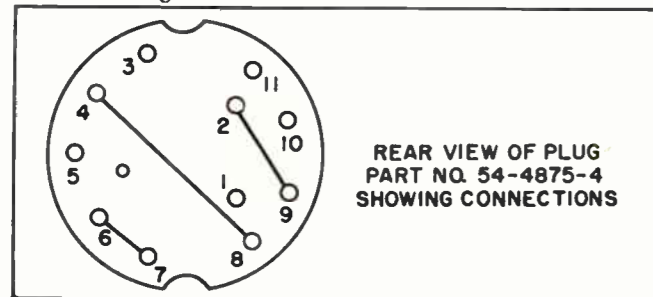

Figure 2.

### PRODUCTION CHANGES IN G-1 DEFLECTION CHASSIS

REASON FOR CHANGE	DESCRIPTION OF CHANGE	NEW OR ADDED PART NO.	OLD OR REMOVED PART NO.	RUN NO.
To remove horizontal foldover.	A 27K, 1/2 w. resistor was inserted in series with R804 to the junction of C800 and C803. An 82-μf. condenser was added, from the junction of the above part and R804 to ground.	66-3278340 60-00825317	— —	4
To recenter horizontal-oscillator frequency control.	Value of horizontal phase comparator voltage-divider resistor, R809, was changed from 390K to 330K.	66-4338240	66-4395244	5
To improve interlace.	C701 and C702 were interchanged. Value of C700 was changed from .033 μf. to .022 μf. Value of R703 was changed from 8200 ohms, 1/2 w., to 3300 ohms, 1/2 w. Value of R700 was changed from 220K, 1/2 w., to 180K, 1/2 w. NOTE: These changes were incorporated in Run 6 chassis only.	— 30-4650-43 66-2338340 66-4188340	— 30-4668-27 66-2828340 66-4228340	6
To improve vertical linearity.	A 680-1/2 w. resistor was added from the junction of R704 and C703, to the center lug of the vertical linearity control (R707).	66-4688340	—	7
To improve horizontal sync performance.	Horizontal-oscillator grid blocking condenser, C808, was reconnected between the green lead from T800 and pin 4 of the horizontal-oscillator tube. The white lead from T800 is now grounded.	—	—	8
To provide for vertical retrace suppression.	A .022-μf. condenser was added, from pin 11 of J800 to pin 10 of J100. Chassis marking G-1A identifies the use of a 300K volume control in place of the 2-megohm tapped control. Also, G-1A does not use bass compensation (R408 and C413).	30-4650-43	—	9
To remove vertical white lines from picture.	220K resistor, R814, was removed. Value of R803 was changed from 2.2 megohms to 680K.	— 66-4688340	66-4228346 66-5228340	9P and 10

### INSTALLATION OF FRINGE-NORMAL KIT ON MODELS USING 81 OR 84 R-F CHASSIS

To improve the over-all sync performance in weak signal areas where strong electrical disturbances are present, a Fringe-Normal Switch Kit, Part No. 45-1883, has been designed. To install this kit, follow this procedure:

1. Remove the cabinet back and fasten the switch assembly, Part No. 76-8328, to the back with the two machine screws (1W10583FA3), two lock washers (1W24254FA1), and two nuts (1W19982FA3) furnished with the kit. Mount the switch (with the yellow color dot toward the top of the cabinet) in the rectangular slot and two mounting holes provided in the back.

2. Paste the Part No. 78-0879 label beside the switch, with "Normal" position toward the top of the cabinet. (The yellow dot on the switch is always the "Normal" position.)

3. Insert the plug of the switch in the "Video Test and Fringe Switch" socket, located on the R-F Chassis.

4. Dress the cable of the switch away from hot tubes.

5. Replace the cabinet back.

In areas where strong signals are received in addition to weak signals, the switch must be in the "Normal" position for reception of strong signals; otherwise, the set might be overloaded.

### PRODUCTION CHANGES IN 71 R-F CHASSIS

REASON FOR CHANGE	DESCRIPTION OF CHANGE	NEW OR ADDED PART NO.	OLD OR REMOVED PART NO.	RUN NO.
To eliminate possible shock hazard due to breakdown in tapered line ass'y.	Two 470-μf. blocking condensers, C522 and C523, were added, in series with 300-ohm antenna leads (in tapered line ass'y.). Two 1-megohm resistors, R512 and R500, were added, one from each side of antenna input to ground.	62-147001001 66-5108340	— —	6
To facilitate production.	Electrolytic filter condenser, C418, was changed.	30-2570-57	30-2570-70	7
To provide increased capacitance required to peak 47.25-mc. trap.	Value of trimmer condenser, C203, was changed from .5 to 3 μf. to 1 to 5 μf.	31-6250-9	31-6250-5	8
To improve sync performance under heavy duty cycle noise.	a. 6AT6 noise-gate tube, V12, was replaced with type 6BF6 tube. b. Plate supply of 6BF6 tube was reduced from 240v to 200v (pin 7 of V12 reconnected to junction of C309, R306, and R311). c. Bias on 6BF6 tube, V12, was changed by disconnecting 3.3-megohm resistor, R600, from junction of R609, R603, and R606, and reconnecting it to junction of R604, R605, C602, and C603.	6BF6 tube — —	6AT6 tube — —	
To provide for vertical retrace suppression.	A lead was added in the chassis interconnecting cable (pin 10 of PL100 to the picture-tube cathode).	—	—	
To facilitate production.	C409, ratio detector buzz by-pass condenser, was changed from 390 μf., mica, to 330 μf., ceramic type.	62-133001001	60-10395417	9
To improve video amplifier operation.	Video output bias resistor, R309, was changed from 1.2 megohms to 680K.	66-4688340	66-5128340	10
To improve picture-tube cutoff.	Picture-tube cathode resistor, R313, was changed from 82K, 1 w., to 68K, 1 w. Picture-tube cathode resistor, R314, was changed from 120K, 1/2 w., to 100K, 1/2 w.	66-3684340 66-4108340	66-3824340 66-4128340	11
To improve frequency response.	Video detector peaking coil, L210, was changed from 180 μh. to 220 μh.	32-4480-15	32-4480-9	12
To reduce sound buzz and beat in picture.	a. Sound i-f screen resistor, R401, was changed from 12K, 1 w., to 33K, 1 w. Screen supply was reduced by disconnecting R401 from junction of C418C and R403, and reconnecting it to junction of R411, R417, and C418A. b. Sound i-f screen by-pass condenser, C404, was removed. c. Sound i-f plate resistor, R402, was removed.	66-3334340 — —	66-3124340 62-215001001 66-1108556	13
To improve fringe-area performance.	A 120K, 1/2 w. resistor was added, from pins 5 and 6 (plates) of noise-gate tube, V12, to lug 4 of video test socket, J200.	66-4128340	—	14
To facilitate production.	Second video i-f trimmer, C208, was changed from lug type to lead type.	31-6520-10	31-6520-9	

### PRODUCTION CHANGES IN G-4 DEFLECTION CHASSIS

REASON FOR CHANGE	DESCRIPTION OF CHANGE	NEW OR ADDED PART NO.	OLD OR REMOVED PART NO.	RUN NO.
To improve operation of width control.	Value of width control, R817, was changed from 20K, 4 w., to 10K, 4 w.	33-5546-49	33-5546-43	2

## PRODUCTION CHANGES IN 1953 PHILCO TELEVISION MODELS

Since the printing of Service Bulletin 52-T3 (PR-2398), the production changes given in the following charts were made on the chassis types listed. For run changes preceding those given in the charts, and for model numbers of the television receivers in which these chassis were used, refer to the charts in Service Bulletin 52-T3 and in this Bulletin. Component reference numbers are those given in the service manuals covering the chassis types in which the changes were made.

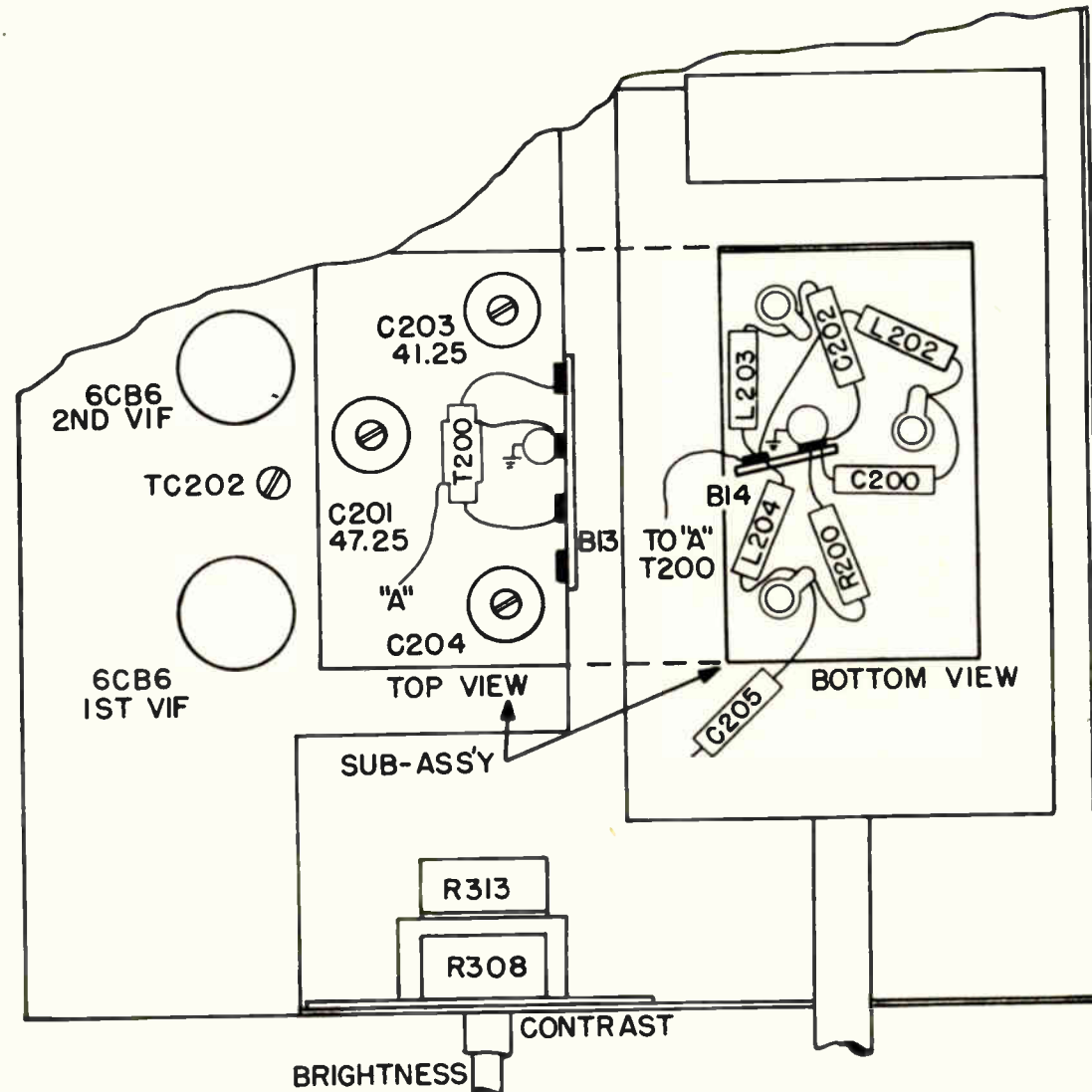

Figure 1.

### PRODUCTION CHANGES IN J-1 DEFLECTION CHASSIS

REASON FOR CHANGE	DESCRIPTION OF CHANGE	NEW OR ADDED PART NO.	OLD OR REMOVED PART NO.	RUN NO.
To eliminate shadow on 21-inch tubes.	A .5- $\mu$ f. condenser was added, in series with horizontal yoke winding (between terminal 1 of T800 and pin 8 of J800).	61-0137	—	2 and 2Z
To improve insulation of 1B3GT tube socket.	The black phenolic 1B3 socket was replaced with a melamine (light-colored) socket.	—	—	3 and 3Y
To reduce possibility of part failure.	The two 3900-ohm, 2 w. resistors, R819 and R820, were replaced with a single 8200-ohm, 7 w. unit.	33-1335-119	66-2395346	4
To reduce possibility of part failure.	The 3900-ohm, 2 w. resistor, R816, was replaced with either a wire-wound 4200-ohm, 5 w. unit, or two 7200-ohm, 2 w. resistors in parallel.	33-1335-101	66-2395346	5
To remove picture distortion.	A 470-ohm resistor was added, across the .5- $\mu$ f. horizontal yoke blocking condenser.	66-1478340	—	—

### PRODUCTION CHANGES IN 81 R-F CHASSIS

REASON FOR CHANGE	DESCRIPTION OF CHANGE	NEW OR ADDED PART NO.	OLD OR REMOVED PART NO.	RUN NO.
To eliminate beat on Channel 5.	First Production. Location of C306, 1000 $\mu$ f., was changed from contrast control to 12BY7 tube socket. L211, L213, and R213 were relocated with respect to terminal board B9.			12Y, 2Y, 3Y, and 4
To facilitate production.	Five-lug terminal board B9 was removed, and replaced by 2-lug and 3-lug terminal boards. All components formerly wired to terminal board B9 were rearranged on the two replacement terminal boards; the circuits remain the same.			5
To reduce snow in medium-signal areas.	C308, 220 $\mu$ f., and C306, 1000 $\mu$ f., were removed from video-output-tube cathode circuit and replaced by a single 1500- $\mu$ f. condenser.			6
To improve sync performance.	R619, delay-bias resistor, was changed from 15 megohms to 10 megohms. A 33- $\mu$ f. condenser was added, from grid (pin 1) of 6BE6 sync separator to ground. A .01- $\mu$ f. condenser was added, in series, between grid (pin 2) of 6U8 sync amplifier and R600. A 1.5-megohm resistor was added, from grid (pin 2) of 6U8 sync amplifier to ground. Resistor R610 was changed from 330K to 470K. Resistor R611 was changed from 180K to 330K. Resistor R613 was changed from 1.2 megohms to 470K. Resistor R614 was changed from 27K to 56K. Resistor R601 was changed from 3300 ohms to 2700 ohms.	66-6108346 30-033001001 30-1238-2 66-5158346 66-4478346 66-4338346 66-4478346 66-3568346 66-3278346	66-6158346	7 8 9
To improve picture quality.	The 1500- $\mu$ f. condenser from cathode (pin 3) of 12BY7 video-output tube to ground was removed.			10 and 10X

### PRODUCTION CHANGES IN 84 R-F CHASSIS

REASON FOR CHANGE	DESCRIPTION OF CHANGE	NEW OR ADDED PART NO.	OLD OR REMOVED PART NO.	RUN NO.
To eliminate audio oscillation.	Lead of condenser C414 was removed from lug 5 of terminal board B8 and connected to lug 8 of terminal board B10.			2
To eliminate beat on Channel 5.	Location of C306, 1000 $\mu$ f., was changed from contrast control to 12BY7 tube socket. L211, L213, and R213 were relocated with respect to terminal board B9; the circuits remain the same.			3
To facilitate production.	Five-lug terminal board B9 was removed and replaced by 2-lug and 3-lug terminal boards. All components formerly wired to terminal board B9 were rearranged on the two replacement terminal boards; the circuits remain the same.			4
	C308, 220 $\mu$ f., and C306, 1000 $\mu$ f., were removed from video-output-tube cathode circuit and replaced by a single 1500- $\mu$ f. condenser.			5

### PRODUCTION CHANGES IN 91 R-F CHASSIS

REASON FOR CHANGE	DESCRIPTION OF CHANGE	NEW OR ADDED PART NO.	OLD OR REMOVED PART NO.	RUN NO.
To improve vert. sync performance.	Sync-separator grid resistor, R609, was changed from 180K to 68K. Sync-separator grid condenser, C604, was changed from 270 $\mu$ f. to 470 $\mu$ f.	66-3688346 30-1225-7	66-4188346 30-1225-9	2
To improve transient response.	A .015- $\mu$ f. condenser was added, from cathode of video amplifier (pin 7 of 6U8) to ground.	30-4650-25		3
To facilitate v-i-f coil alignment.	First video i-f coil was replaced by one of lower inductance.	32-4548-28	32-4548-24	3A and 4
To facilitate v-i-f coil alignment.	A 12K resistor was added, across 4th v-i-f transformer secondary (lug 2 of terminal board B8 to ground).	66-3128346		
To permit use of UHF Tuner.	Bare wire lead between lugs 4 and 5 of terminal board B7 was removed. Red output-transformer lead was disconnected from lug 4 of B7 and connected to lug 5 of B7. Female UHF adapter cable was connected to lug 3 of terminal board B7. Male UHF adapter cable was connected to lug 4 of B7.	41-4099-1 41-4166		5 6
To reduce i-f interference.	The 47.25-mc. and 41.25-mc. traps, 1st v-i-f trimmer, and associated parts were removed from the chassis and remounted in a shielded subassembly on top of the chassis. Figure 1 shows new location of trimmers and parts that were removed.			

PRODUCTION CHANGES IN 94 R-F CHASSIS

REASON FOR CHANGE	DESCRIPTION OF CHANGE	NEW OR ADDED PART NO.	OLD OR REMOVED PART NO.	RUN NO.
To facilitate v-i-f coil alignment. To permit use of UHF Tuner.	A 12K resistor was added, across 4th v-i-f transformer secondary (lug 2 of terminal board B8 to ground). Lead of resistor R518, 15K was moved from lug 5 to lug 4 of terminal board B7. Red lead of audio-output transformer was disconnected from lug 4 of terminal board B7 and re-connected to lug 4 of audio-output-tube (V12) socket. Lead of condenser C416*, 3300 $\mu$ f., was removed from lug 5 of terminal board B7 and reconnected to lug 3 of R224. Red lead between lug 4 of terminal board B7 and lug 5 of audio-output-tube (V12) socket was removed. Female UHF adapter cable was connected to lug 5 of terminal board B7. Male UHF adapter cable was connected to lug 4 of terminal board B7.	66-3128346		1A and 2
To reduce audio distortion.	A 22-megohm resistor was added, in parallel with C417, in grid circuit of 1st audio tube (V11B).	41-4099-1		3
To reduce i-f interference.	The 47.25-mc. and 41.25-mc. traps, 1st v-i-f trimmer, and associated parts were removed from the chassis and remounted in a shielded subassembly on top of the chassis. Figure 1 shows new location of trimmers and parts that were moved.	41-4166		4
	* Through error, condenser C416 appears as C146 in figure 38 of Service Manual PR-2395.	66-6228546		

PRODUCTION CHANGES IN J-1 DEFLECTION CHASSIS

REASON FOR CHANGE	DESCRIPTION OF CHANGE	NEW OR ADDED PART NO.	OLD OR REMOVED PART NO.	RUN NO.
To reduce horizontal wavy lines (caused by ringing in horizontal-deflection yoke windings).	Anti-ringing condenser, C813, was changed from 56 $\mu$ f. to 68 $\mu$ f.	30-1243-4	30-1243-5	6
To eliminate picture weave.	Filament circuit wiring was revised as follows: Black lead from filament transformer, T100, was moved from lug 7 to lug 6 of interchassis socket, J101. Filament fuse wire (between lugs 6 and 7 of terminal board B6) was removed and connected between lugs 6 and 7 of interchassis socket, J101. Black wire connecting lug 5 of vertical output-tube (V16) socket to lug 2 of terminal board B8 was removed. A black wire was added, from lug 4 of vertical-output-tube (V16) socket to lug 6 of terminal board B6. A black wire was added, from lug 5 of vertical-output-tube (V16) socket to lug 4 of vertical oscillator-tube (V15) socket. Yellow wire from lug 3 of phase-comparer-tube (V17) socket to lug 3 of terminal board B5 was removed. A black wire was added, from lug 3 of phase-comparer-tube (V17) socket to lug 9 of horizontal oscillator-tube (V18) socket. Black wire from lug 9 of horizontal-oscillator-tube (V18) socket to lug 3 of terminal board B5 was removed. Strap wire from lug 2 of horizontal-output-tube (V19) socket to chassis was removed. Lead of condenser C810 was removed from lug 2 of horizontal-output-tube (V19) socket and grounded to chassis. A black wire was added, from lug 9 of horizontal-oscillator-tube (V18) socket to lug 2 of horizontal-output-tube (V19) socket. Yellow wire from lug 7 of damper-tube (V20) socket to chassis was removed. A black wire was added, from lug 2 of horizontal-output-tube (V19) socket to lug 7 of damper-tube (V20) socket. Yellow wire from lug 1 of interchassis socket J101, to chassis was removed. A black wire was added, from lug 7 of damper-tube (V20) socket to lug 1 of interchassis socket, J101. Resistor R709, 47 ohms, was removed from lugs 3 and 5 of vertical-output-tube (V16) socket and connected between lugs 5 and 6 of terminal board B8. A yellow wire was added, from lug 5 of terminal board B8 to lug 3 of vertical-output-tube (V16) socket.			7
To increase picture width.	Resistor R818 was changed from 22K to 33K.	66-3335346	66-3225346	8
To improve operation of controls.	Resistor R813 was changed from 470K to 270K.	66-4278346	66-4478546	
	Both vertical height and vertical linearity controls, R704 and R708, were changed from 5 megohms to 2.5 megohms.	33-5565-32	33-5565-31	9

PRODUCTION CHANGES IN J-4 DEFLECTION CHASSIS

REASON FOR CHANGE	DESCRIPTION OF CHANGE	NEW OR ADDED PART NO.	OLD OR REMOVED PART NO.	RUN NO.
To increase picture width.	Resistor R818 was changed from 22K to 33K.	66-3335346	66-3225346	2
To reduce hum in radio operation.	A .047- $\mu$ f., 600v condenser was added, across a-c line, from lug 4 of C101 to lug 7 of terminal board B5.	66-4278346	66-4478546	
		30-4668-62		1Z and 2Z

PRODUCTION CHANGES IN H-1 DEFLECTION CHASSIS

REASON FOR CHANGE	DESCRIPTION OF CHANGE	NEW OR ADDED PART NO.	OLD OR REMOVED PART NO.	RUN NO.
To eliminate picture weave and high-voltage corona.	Filament circuit wiring was revised as follows: Black lead from filament transformer, T100, was moved from lug 7 to lug 5 of interchassis socket, J101. Filament fuse wire, between lugs 2 and 4 of terminal board B5, was removed and connected between lugs 5 and 7 of interchassis socket, J101. Wire from lug 4 of vertical-output-tube (V12) socket to lug 2 of terminal board B7 was removed. A wire was added, from lug 3 of vertical-output-tube (V12) socket to lug 2 of terminal board B7. Jumper wire between lugs 3 and 4 of vertical-output-tube (V12) socket was removed. A wire was added, from lug 4 of vertical-output-tube (V12) socket to lug 4 of terminal board B5. Wire from lug 3 of phase-comparer-tube (V13) socket to lug 2 of terminal board B5 was removed. A wire was added, from lug 4 of vertical-output-tube (V12) socket to lug 3 of phase-comparer-tube (V13) socket. Wire from lug 2 of terminal board B5 to lug 9 of horizontal-oscillator-tube (V14) socket was removed. A wire was added, from lug 3 of phase-comparer-tube (V13) socket to lug 9 of horizontal-oscillator-tube (V14) socket. Grounding strap from lug 2 of horizontal-output-tube (V15) socket was removed. A wire was added, from lug 9 of horizontal-oscillator-tube (V14) socket to lug 2 of horizontal-output-tube (V15) socket. Lead from lug 8 of damper-tube (V16) socket to ground was removed. A wire was added, from lug 2 of horizontal-output-tube (V15) socket to lug 8 of damper-tube (V16) socket. Wire from lug 1 of interchassis socket, J101, to ground was removed. A wire was added, from lug 8 of damper-tube (V16) socket to lug 1 of interchassis socket, J101. A corona shield was added.			2
To increase picture height.	Resistor R818 was changed from 22K to 33K. Resistor R712 was changed from 680K to 470K. Resistor R813 was changed from 470K to 270K.	56-9684FA3 66-3394346 66-4478340 66-4278346	66-3225346 66-4688340 66-4478546	3
To facilitate production.	Resistors R800 and R804 each 4.7 megohms, and condensers C802, .001 $\mu$ f., and C803, .01 $\mu$ f., were replaced with printed circuit. Printed circuit connections are as follows: Lead 1 to lug 1 of terminal board B3; lead 2 to chassis ground, near lug 9 of horizontal-oscillator-tube (V14) socket; and lead 3 to lug 7 of horizontal-oscillator-tube (V14) socket. Resistor R817, 68K, was removed and reconnected between lugs 3 and 4 of terminal board B4. Condenser C804, .001 $\mu$ f., was removed and reconnected between lug 7 of phase-comparer-tube (V13) socket and lug 4 of terminal board B4. Lead from lug 1 of terminal board B3 to lug 1 of terminal board B1 was removed and reconnected from lug 1 of terminal board B3 to lug 5 of terminal board B4. Lead from lug 7 of horizontal-oscillator-tube (V14) socket to lug 4 of terminal board B4 was removed and reconnected from lug 1 of terminal board B1 to lug 5 of deflection socket, J800. Note: These changes were incorporated in run 3P only.	30-6003	66-5478546 30-1238-3 30-1238-2	3P
To improve operation of height control.	Vertical height control, R709*, was changed from 5 megohms to 2.5 megohms.	33-5565-32	33-5565-31	4
To reduce picture bend.	**Condenser C804 was changed from .01 $\mu$ f. to .001 $\mu$ f.	30-1238-3	30-1238-2	5
To increase range of vertical linearity control.	Vertical linearity control, R711, was changed from 1 megohm to 2.5 megohms.	33-5565-32	33-5565-42	6
To facilitate production.	Condensers C104 and C105, each .01 $\mu$ f., 600v, were removed. * The value of R709 is incorrectly listed as 2.5 megohms in Service Manual PR-2374. For chassis prior to Run 4, the value of this part should be 5 megohms. ** This change was shown in Service Manual PR-2374.		30-1226-1	7

PRODUCTION CHANGES IN H-4 DEFLECTION CHASSIS

REASON FOR CHANGE	DESCRIPTION OF CHANGE	NEW OR ADDED PART NO.	OLD OR REMOVED PART NO.	RUN NO.
To reduce high-voltage corona.	A corona shield was added.	56-9684FA3		2
To increase picture height.	Resistor R818 was changed from 22K to 33K. Resistor R712 was changed from 680K to 470K. Resistor R813 was changed from 470K to 270K.	66-3394346 66-4478340 66-4278346	66-3225346 66-4688340 66-4478546	3
To improve operation of controls.	†Vertical height control, R709, was changed from 5 megohms to 2.5 megohms. Vertical linearity control, R711, was changed from 1 megohm to 2.5 megohms. Lead from lug 3 of phase-comparer-tube (V13) socket to lug 2 of horizontal-output-tube (V15) socket was removed and reconnected from lug 3 of phase-comparer-tube socket to lug 9 of horizontal-oscillator-tube (V14) socket.	33-5565-32 33-5565-32	33-5565-31 33-5565-42	4
To reduce picture bend.	Condenser C804 was changed from .01 $\mu$ f. to .001 $\mu$ f. † This change was shown in Service Manual PR-2402.	30-1238-3	30-1238-2	5

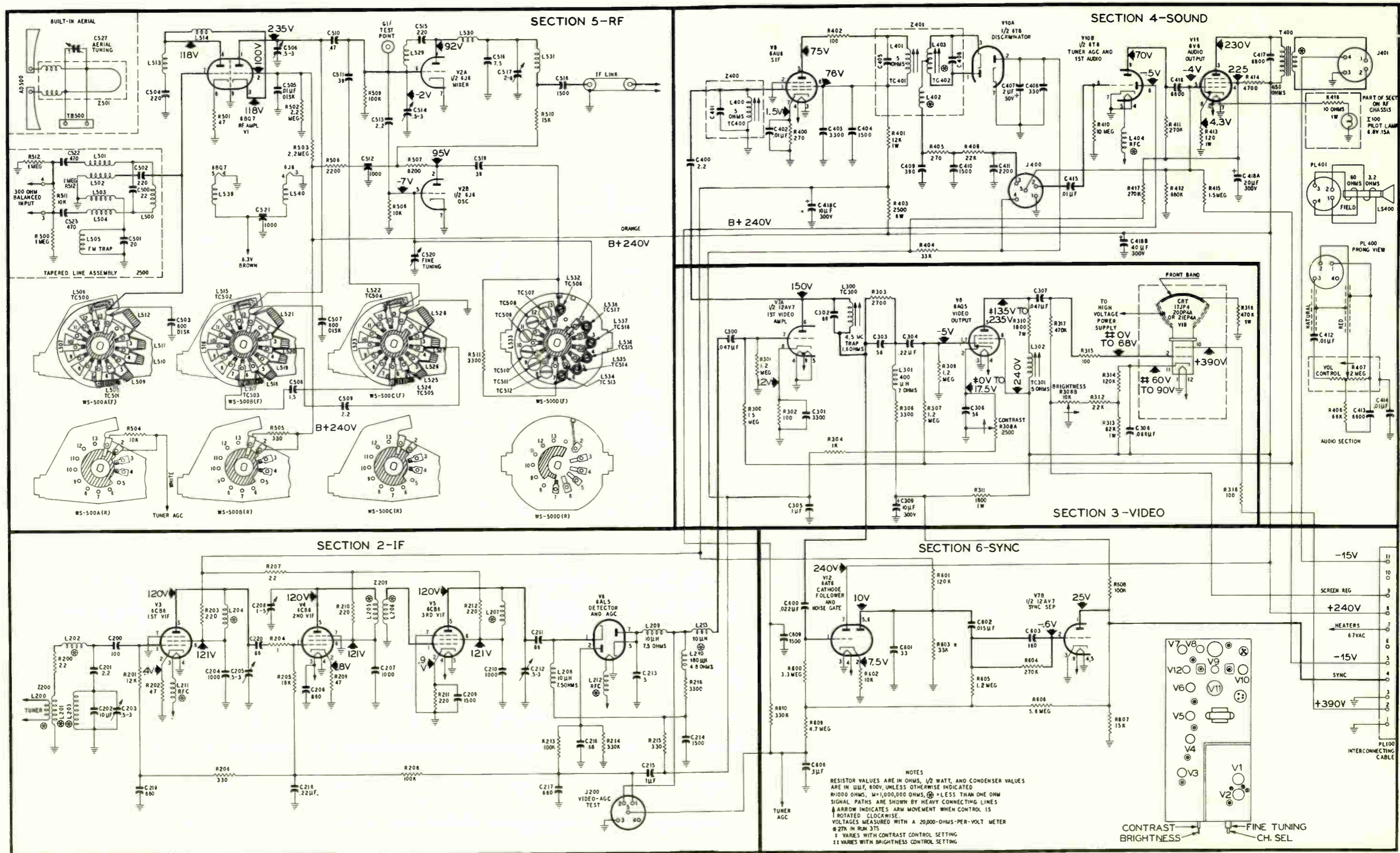

Figure 35 Chassis 71, Runs 3T5, 4S, and 5, Schematic Diagram

TP1-2784-2

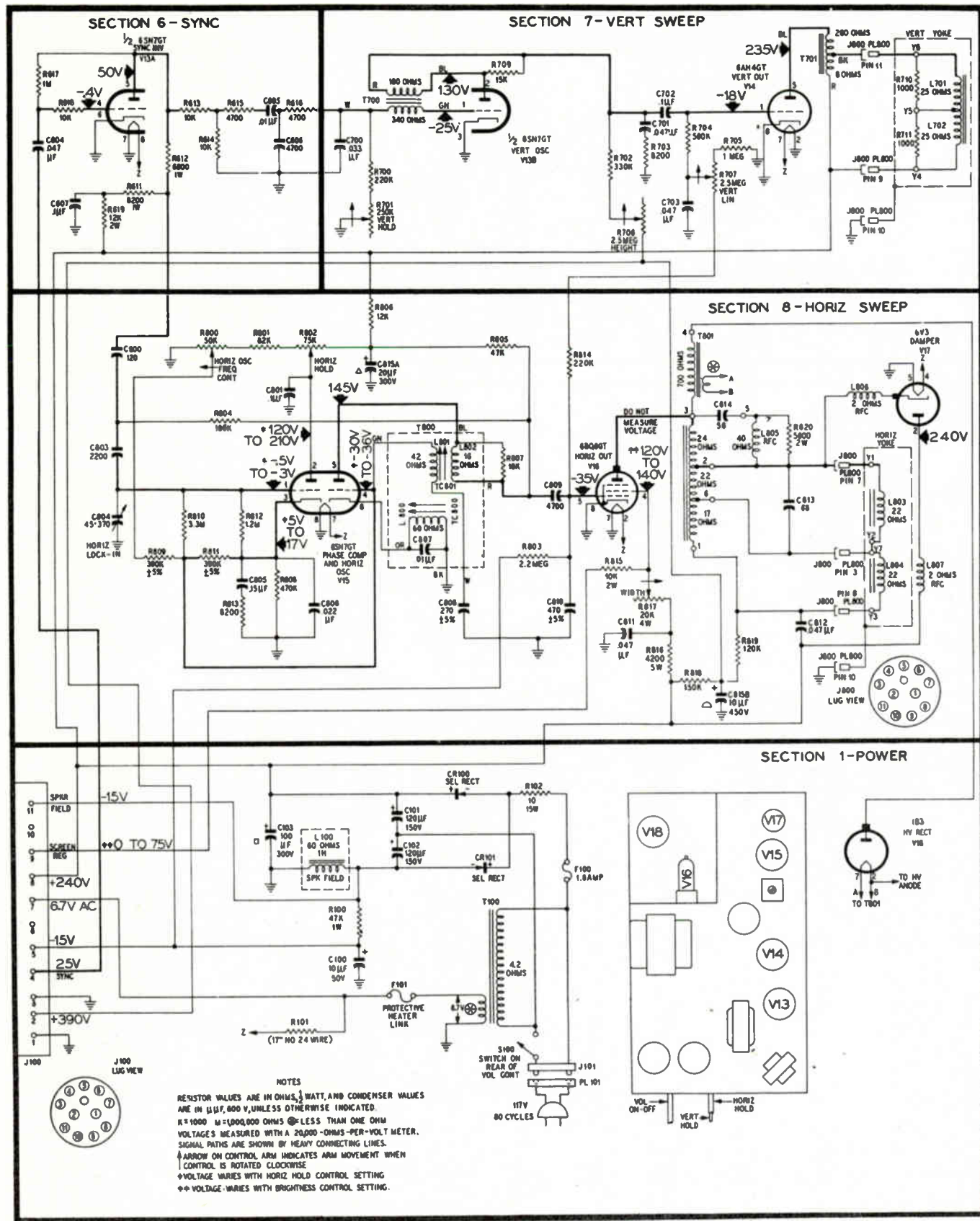

Figure 36. Deflection Chassis G-1, Runs 1V, 2V, and 3 Schematic Diagram

TP1-2783-2

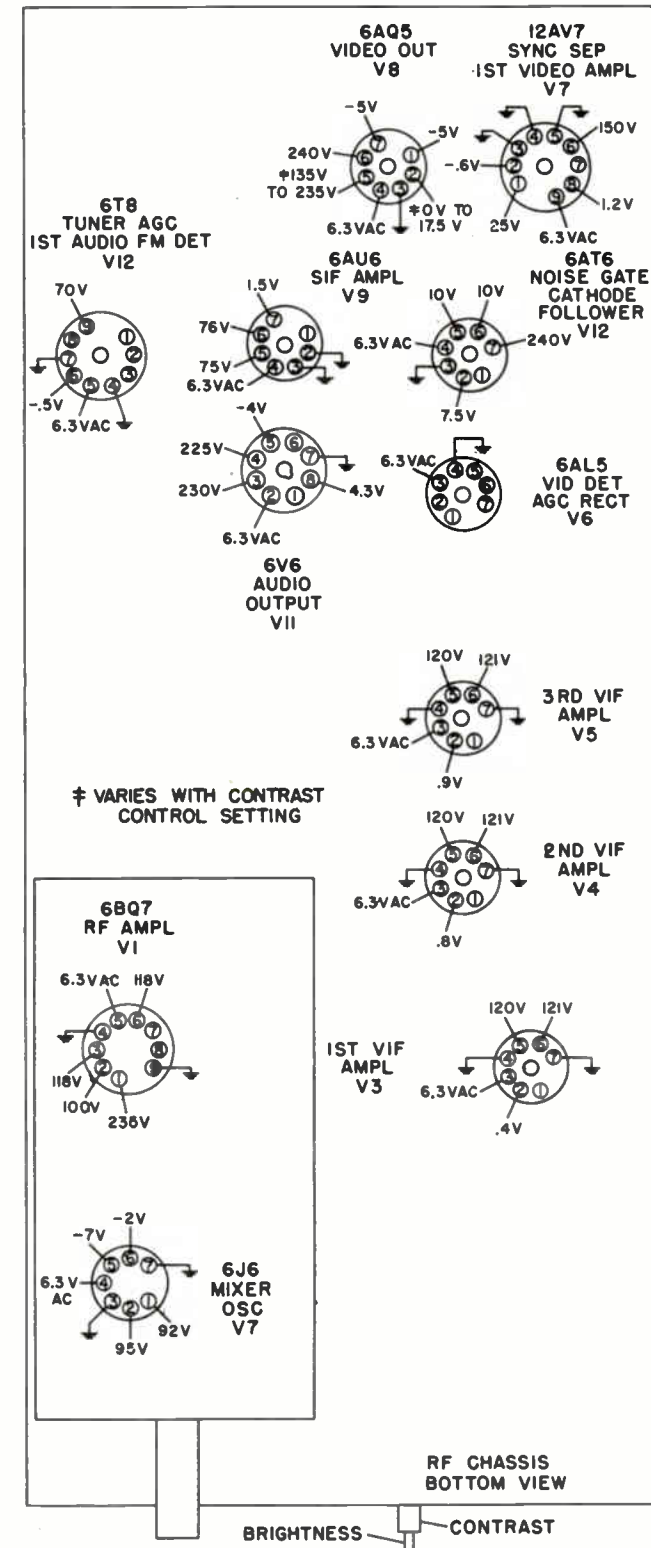

Figure 31. RF Chassis 71, Bottom View, Showing Voltages at Socket Pins

TP2-1135

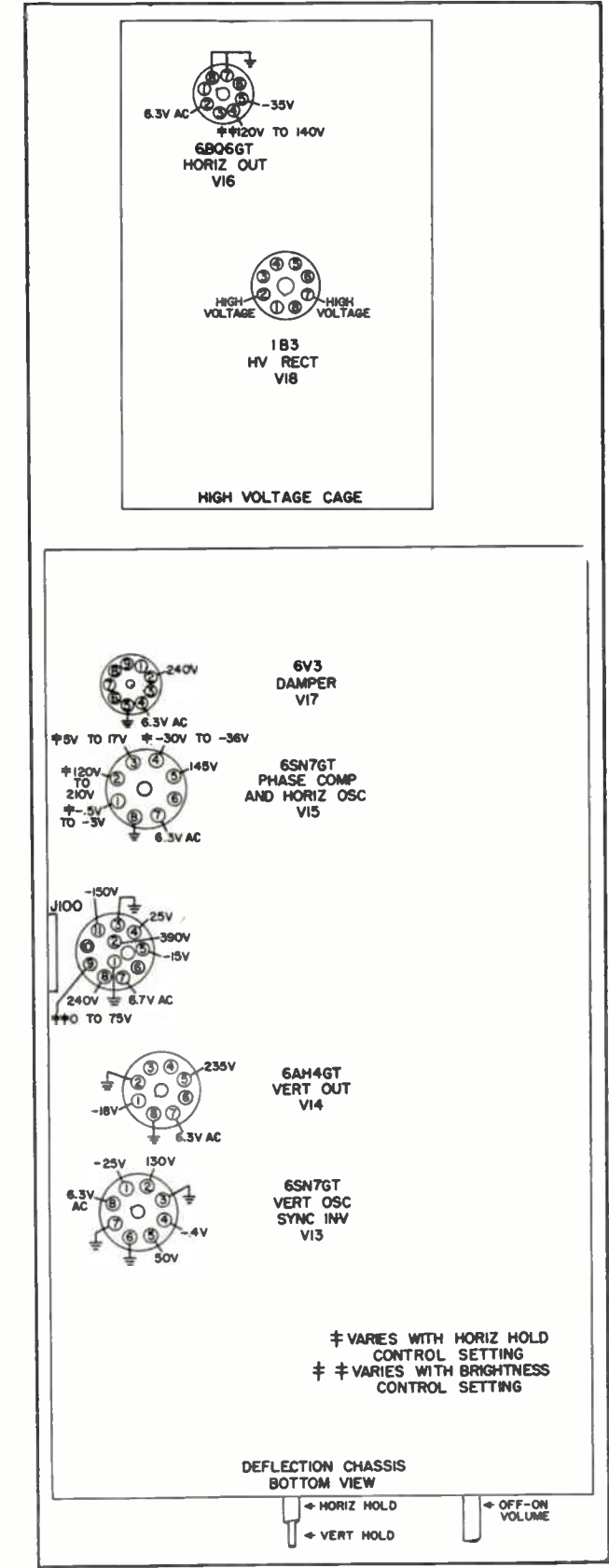

Figure 32. Deflection Chassis G-1, Bottom View, Showing Voltages at Socket Pins

TP2-1136

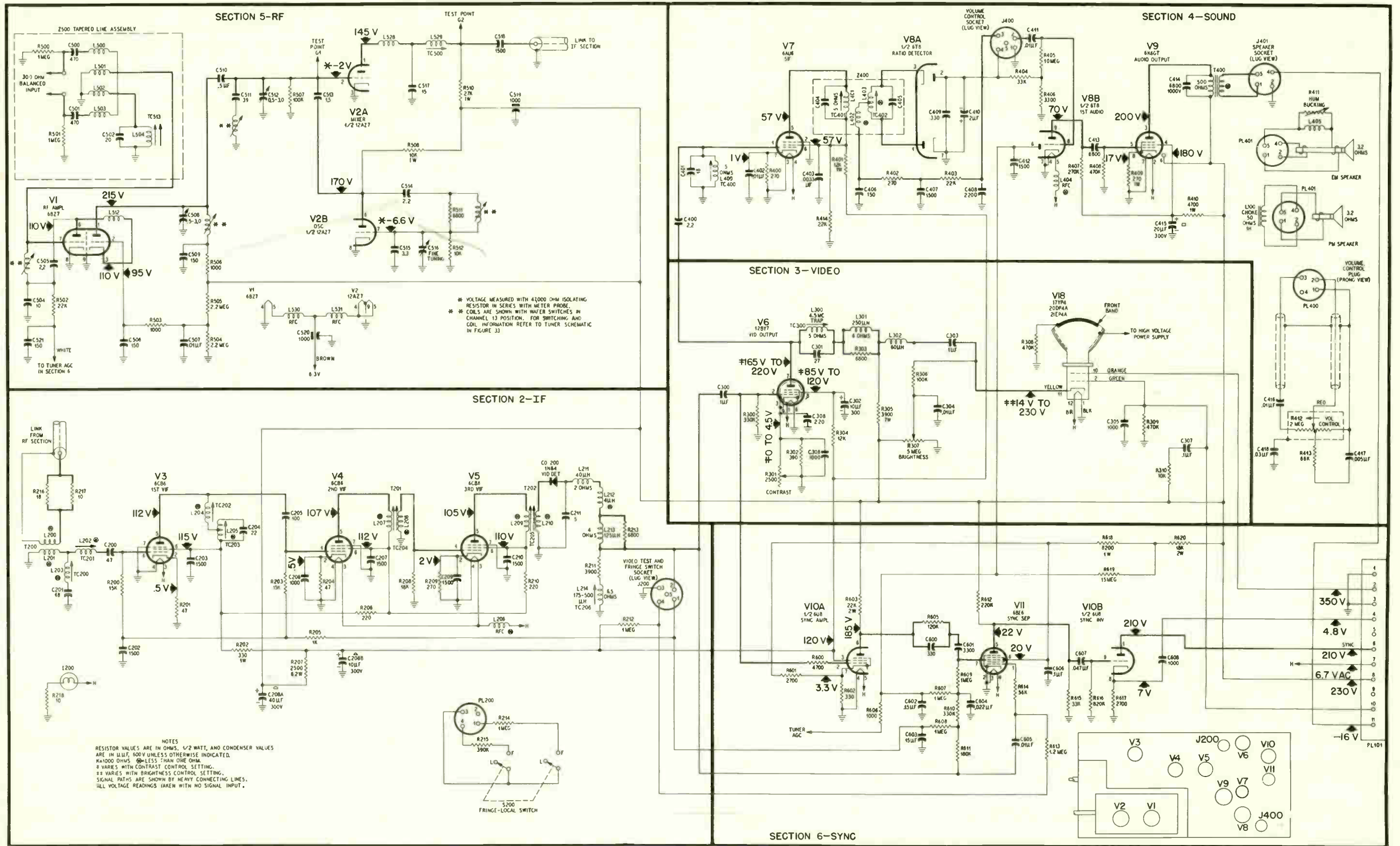

Figure 35. R-F Chassis 81, Schematic Diagram

TP2-2208



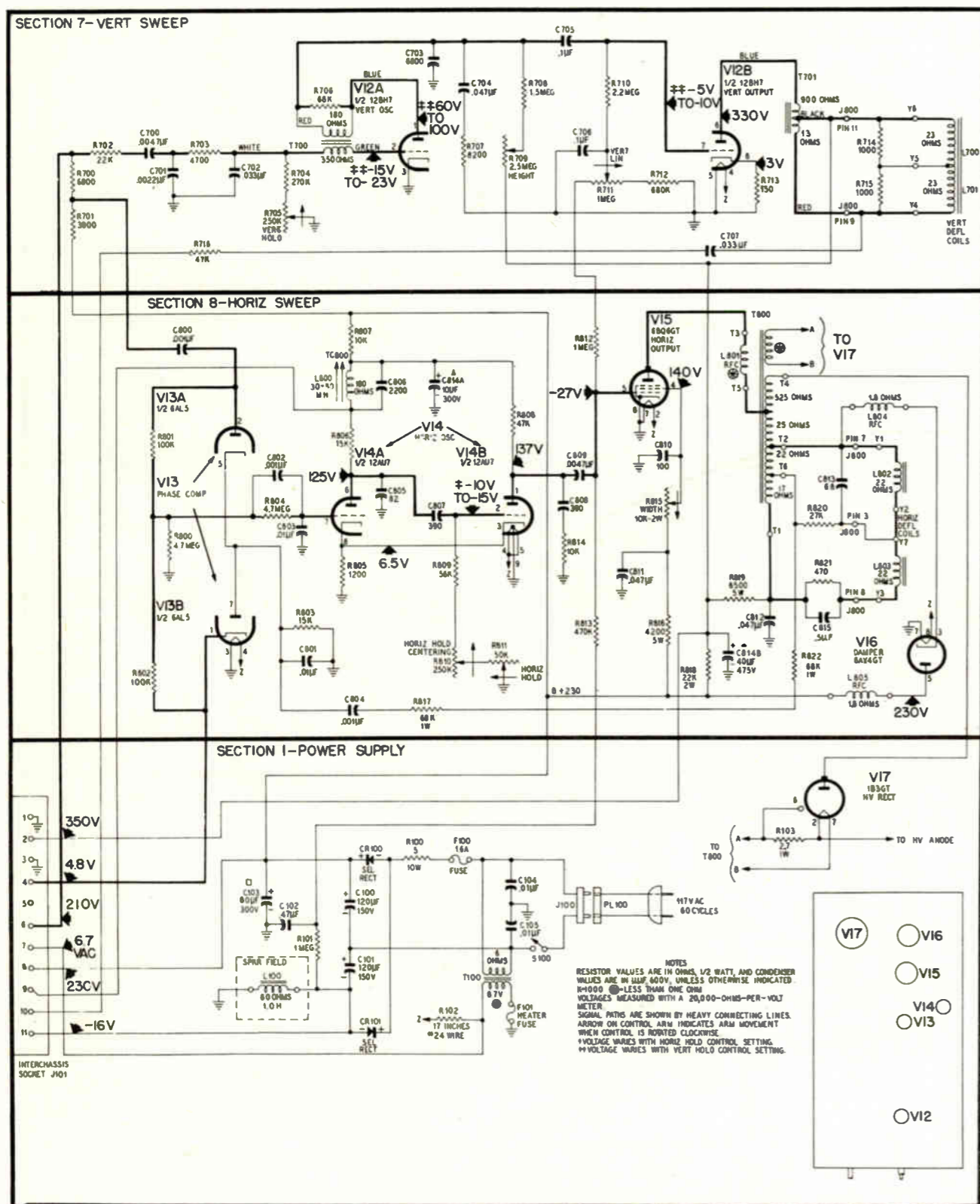
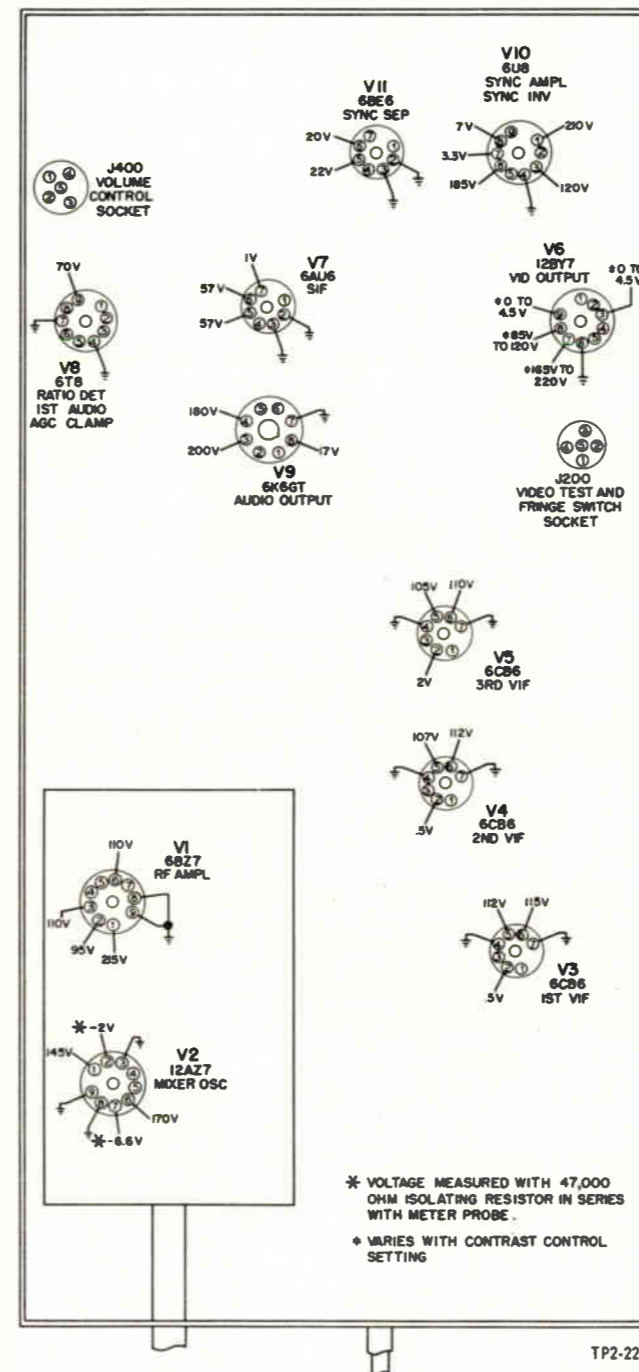

Figure 36. Deflection Chassis H-1, Schematic Diagram

TP2-2209



TP2-2203

Figure 30. R-F Chassis 81, Bottom View, Showing Voltages at Socket Pins

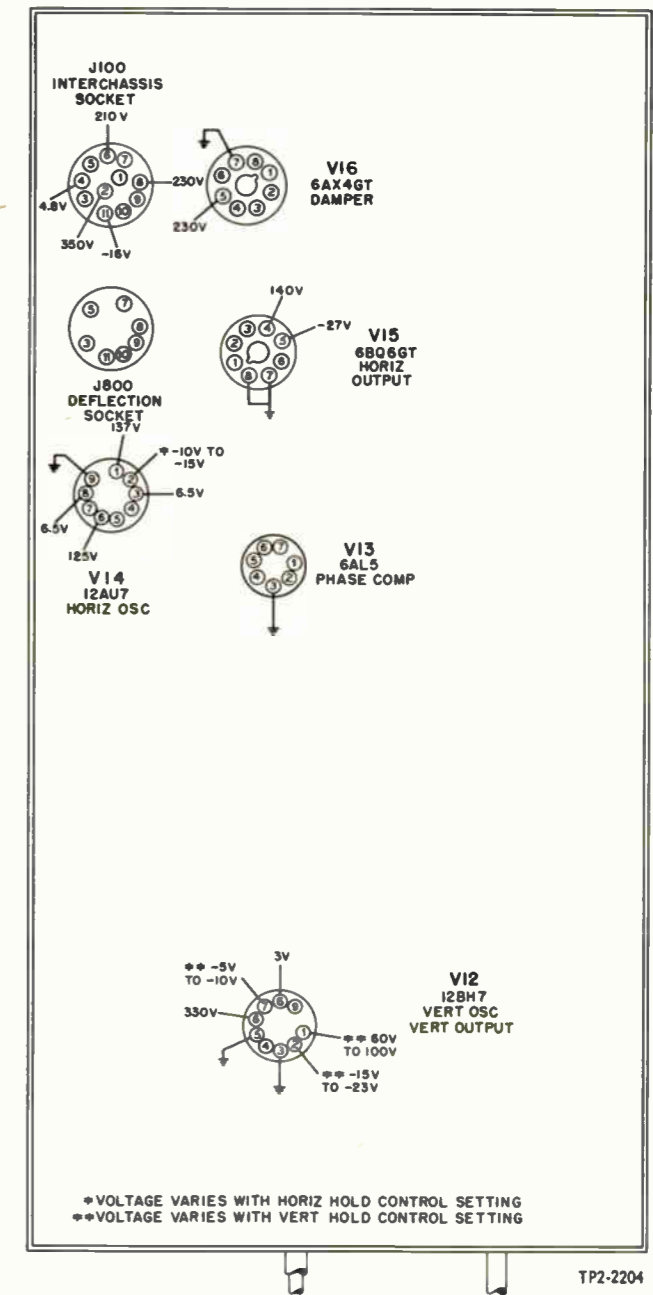

TP2-2204

Figure 31. Deflection Chassis H-1, Bottom View, Showing Voltages at Socket Pins



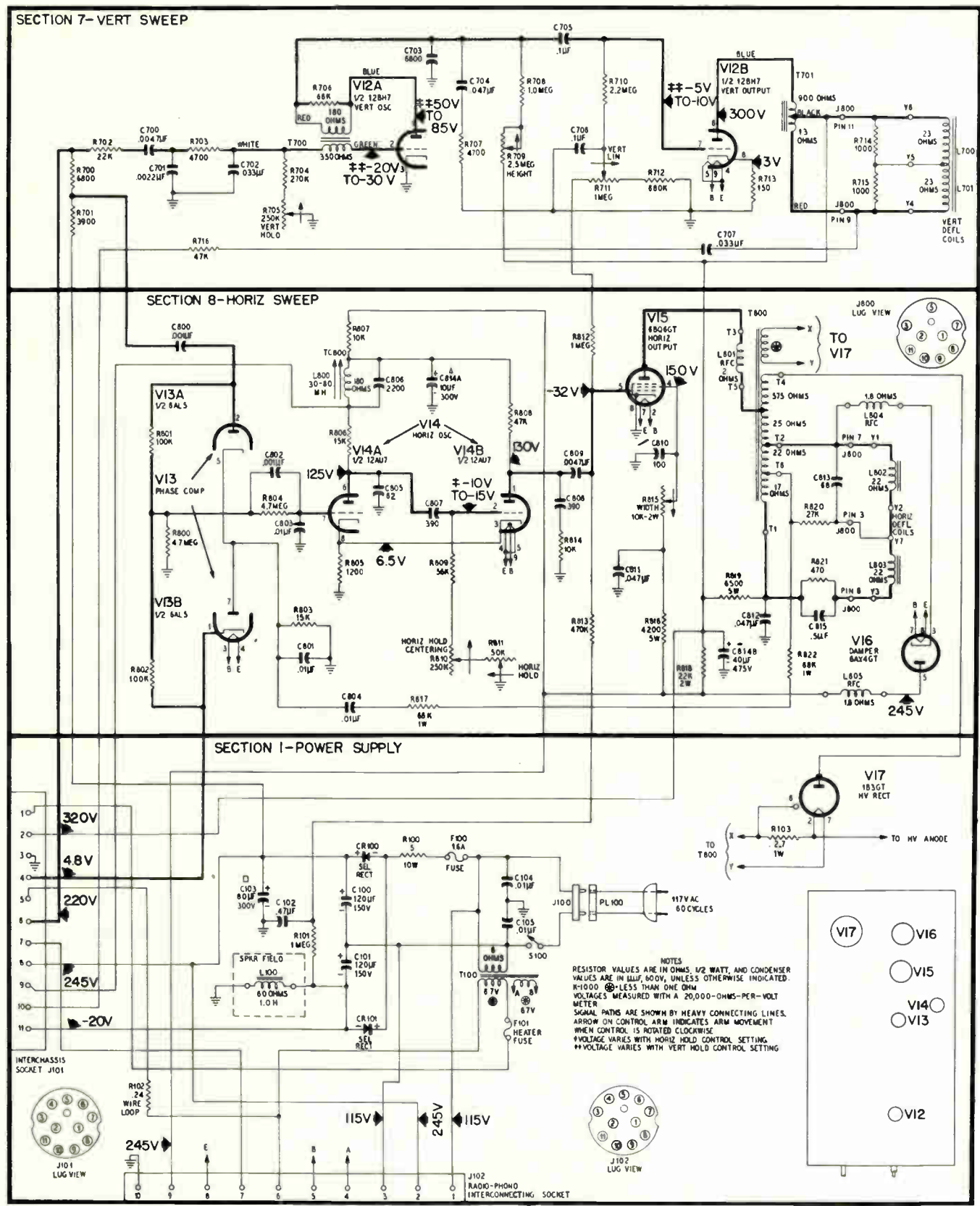

Figure 36. Deflection Chassis H-4, Schematic Diagram

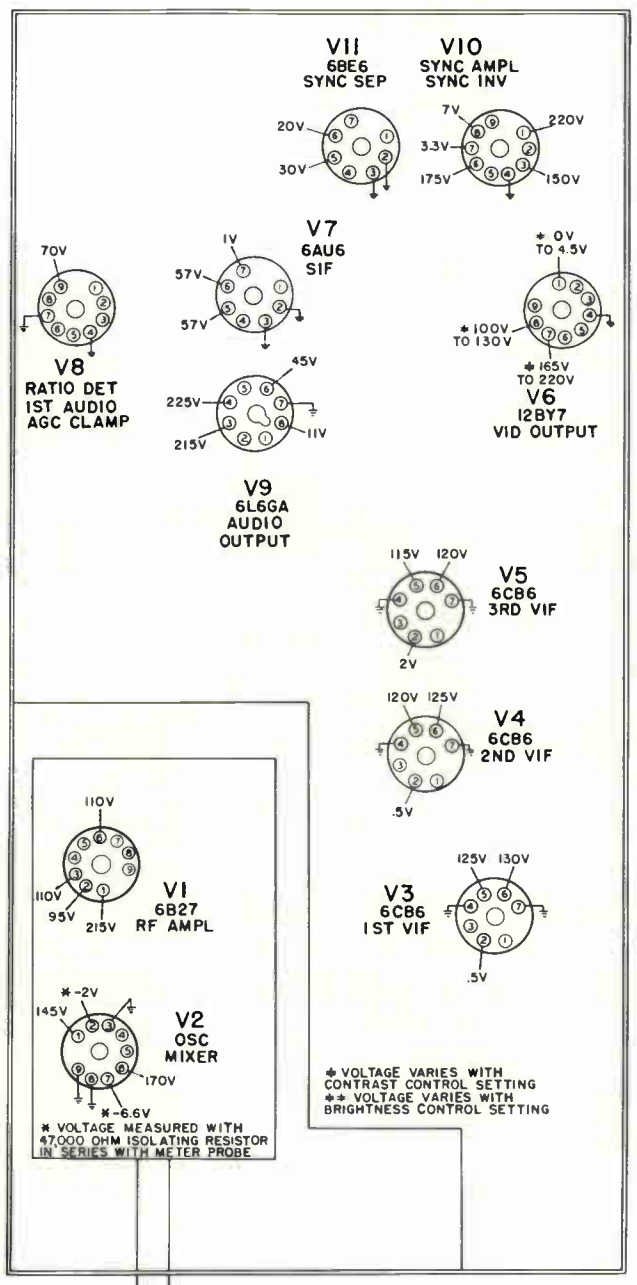

Figure 30. R-F Chassis 84, Bottom View, Showing Voltages at Socket Pins

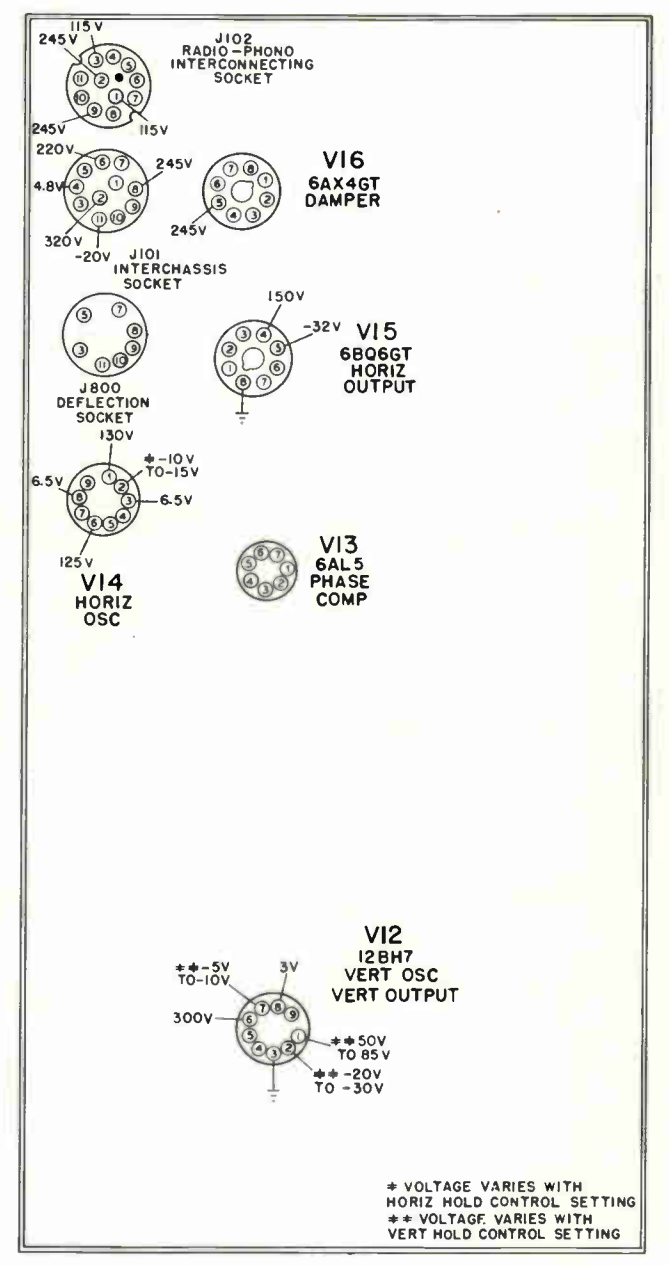

Figure 31. Deflection Chassis H-4, Bottom View, Showing Voltages at Socket Pins

TP2-2239

TP2-2235

TP2-2236

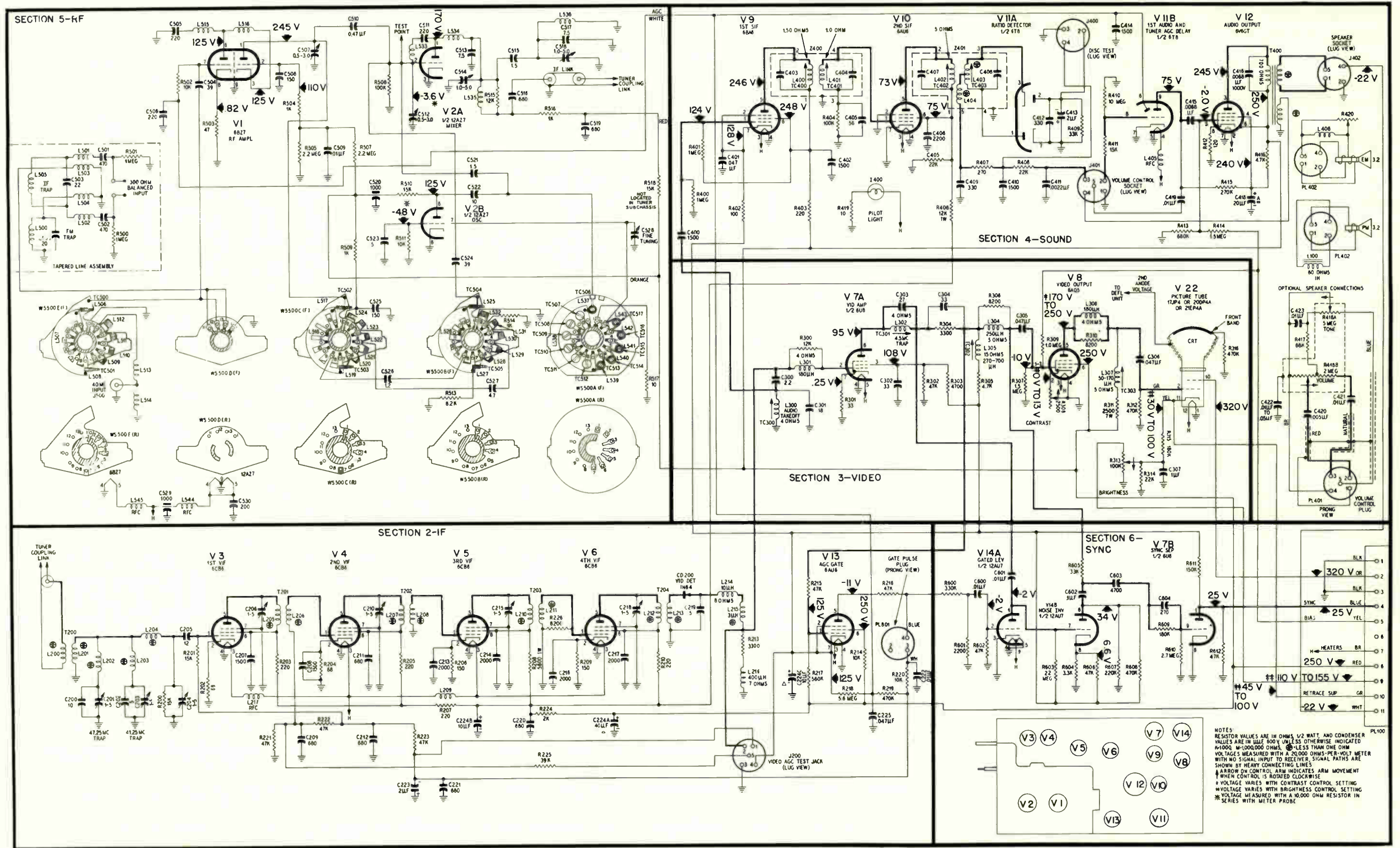

Figure 37. R-F Chassis 91, Schematic Diagram

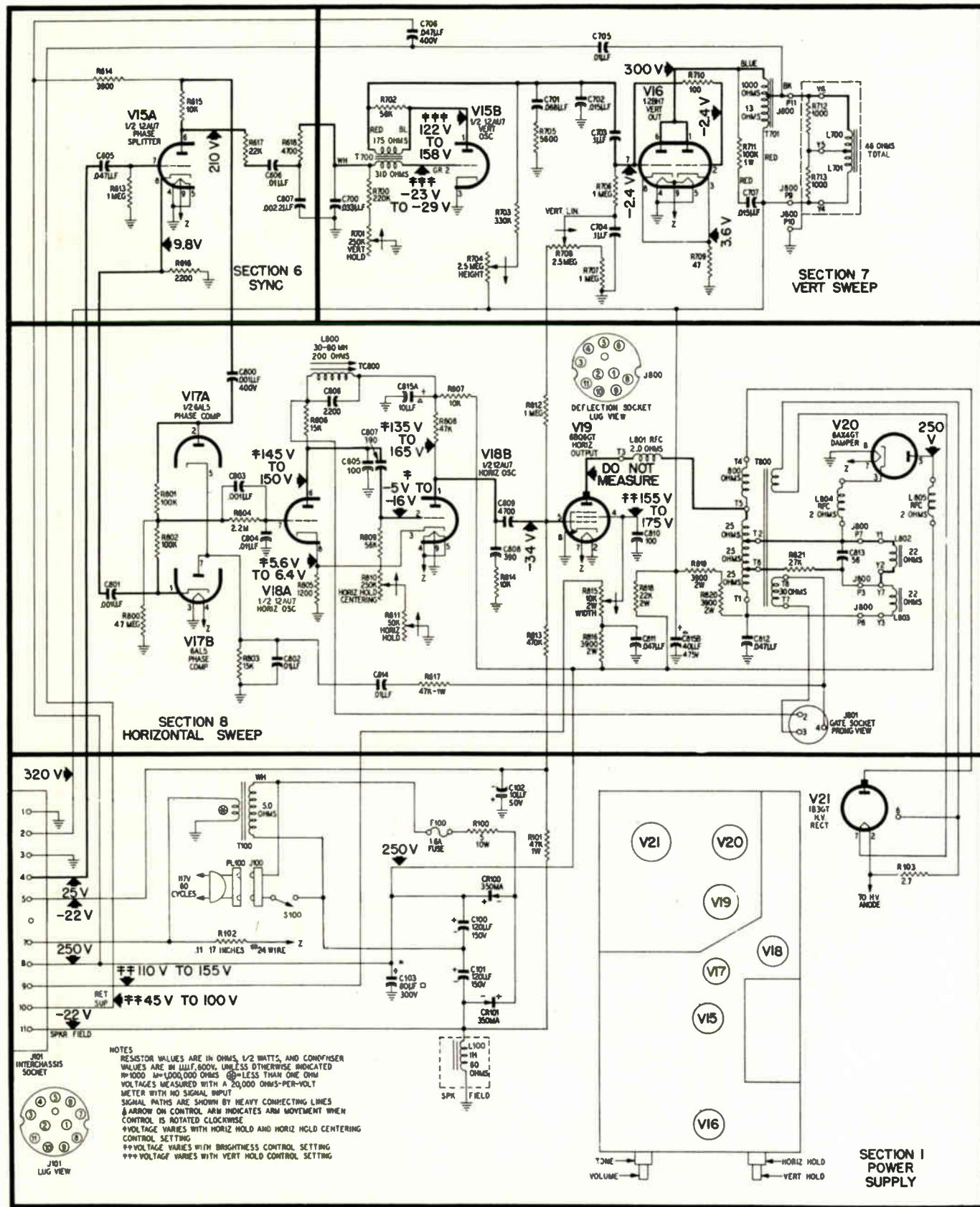
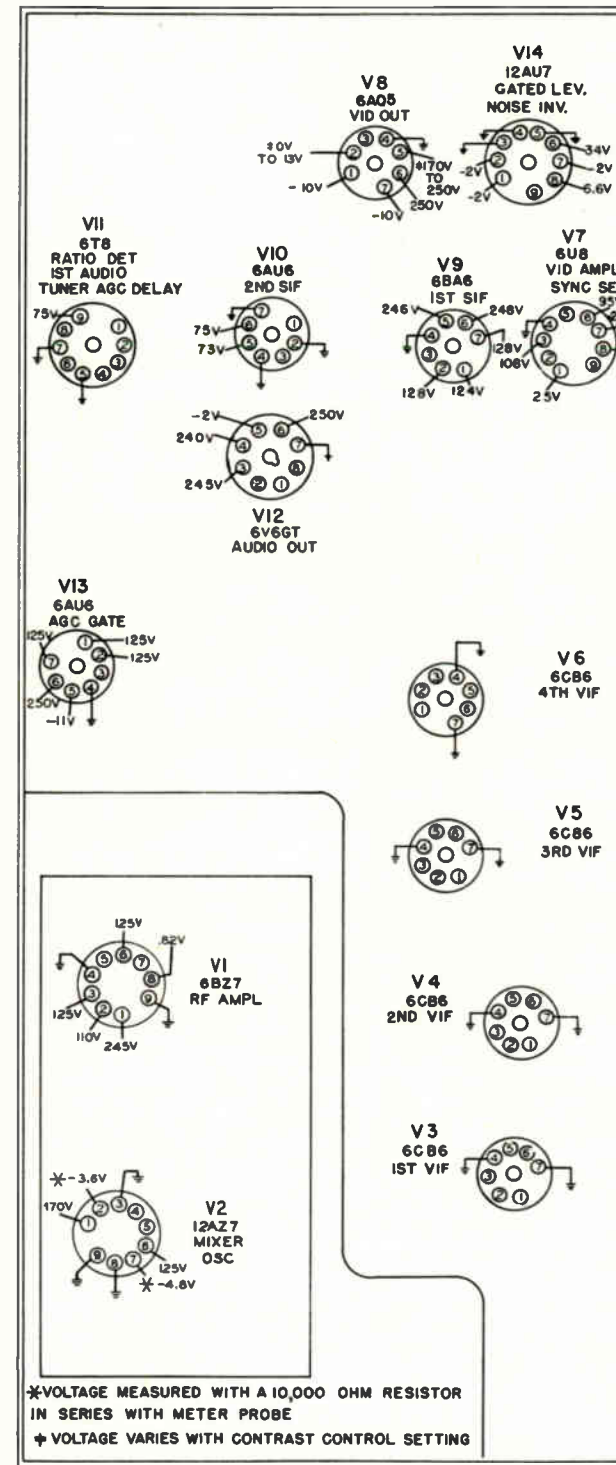

Figure 38. Deflection Chassis J-1, Schematic Diagram

TP2-1516



TP2-1512

Figure 33. R-F Chassis 91, Bottom View, Showing Voltages at Socket Pins

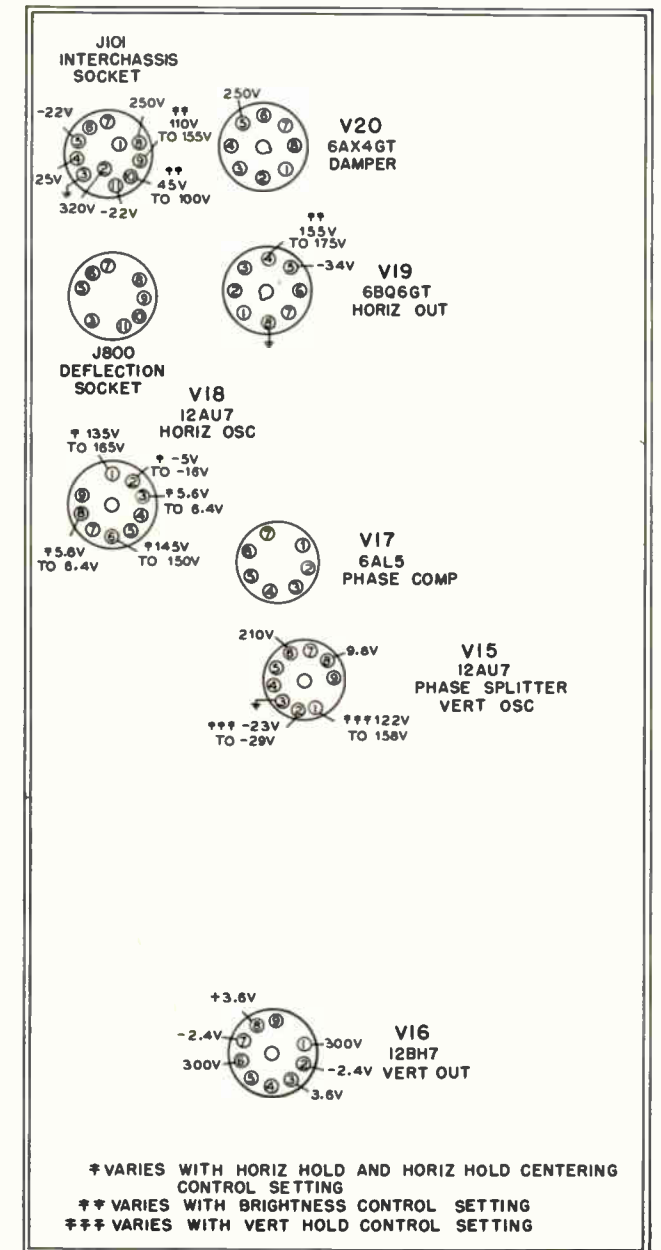

TP2-1513

Figure 34. Deflection Chassis J-1, Bottom View, Showing Voltages at Socket Pins

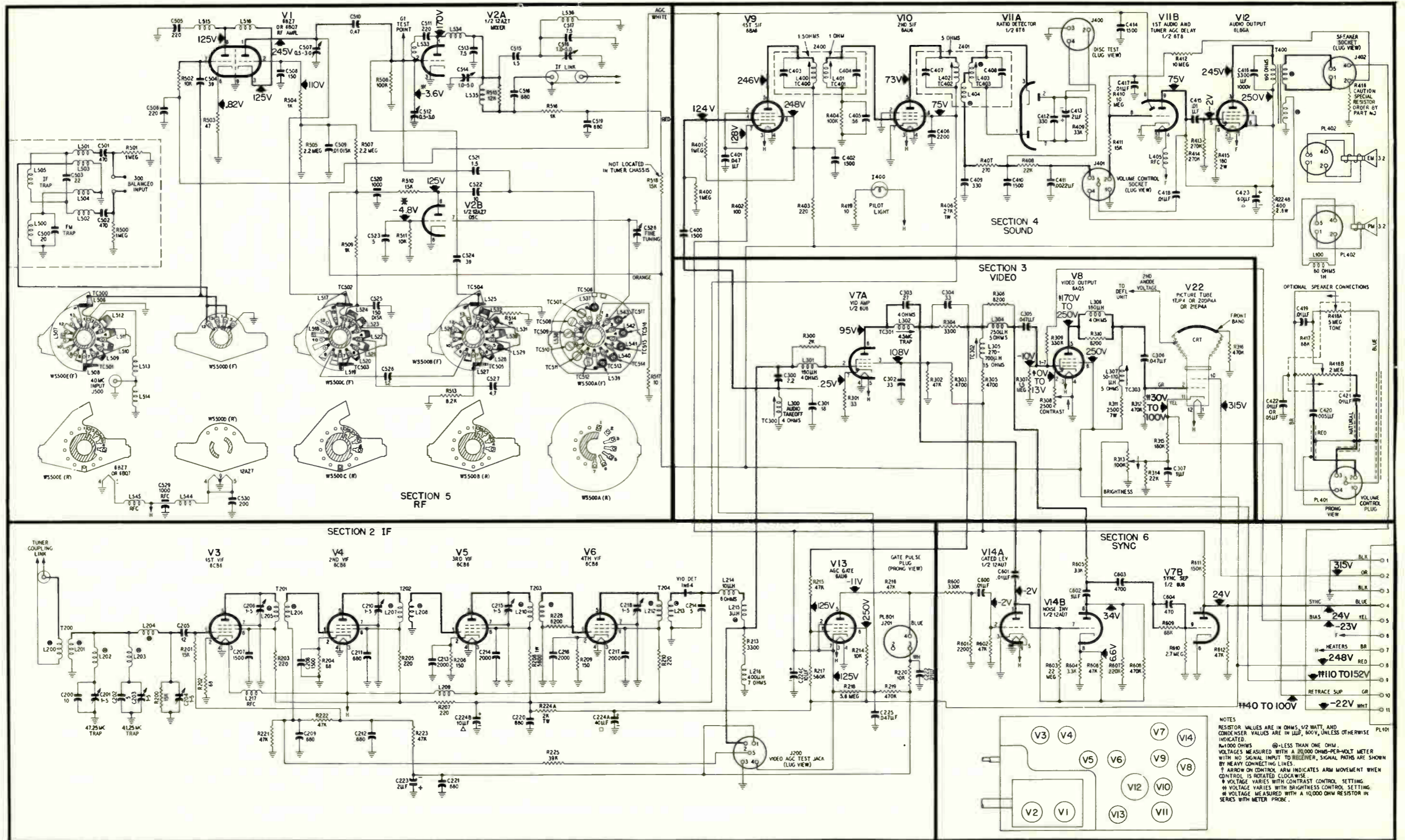

Figure 39. R-F Chassis 94, Schematic Diagram

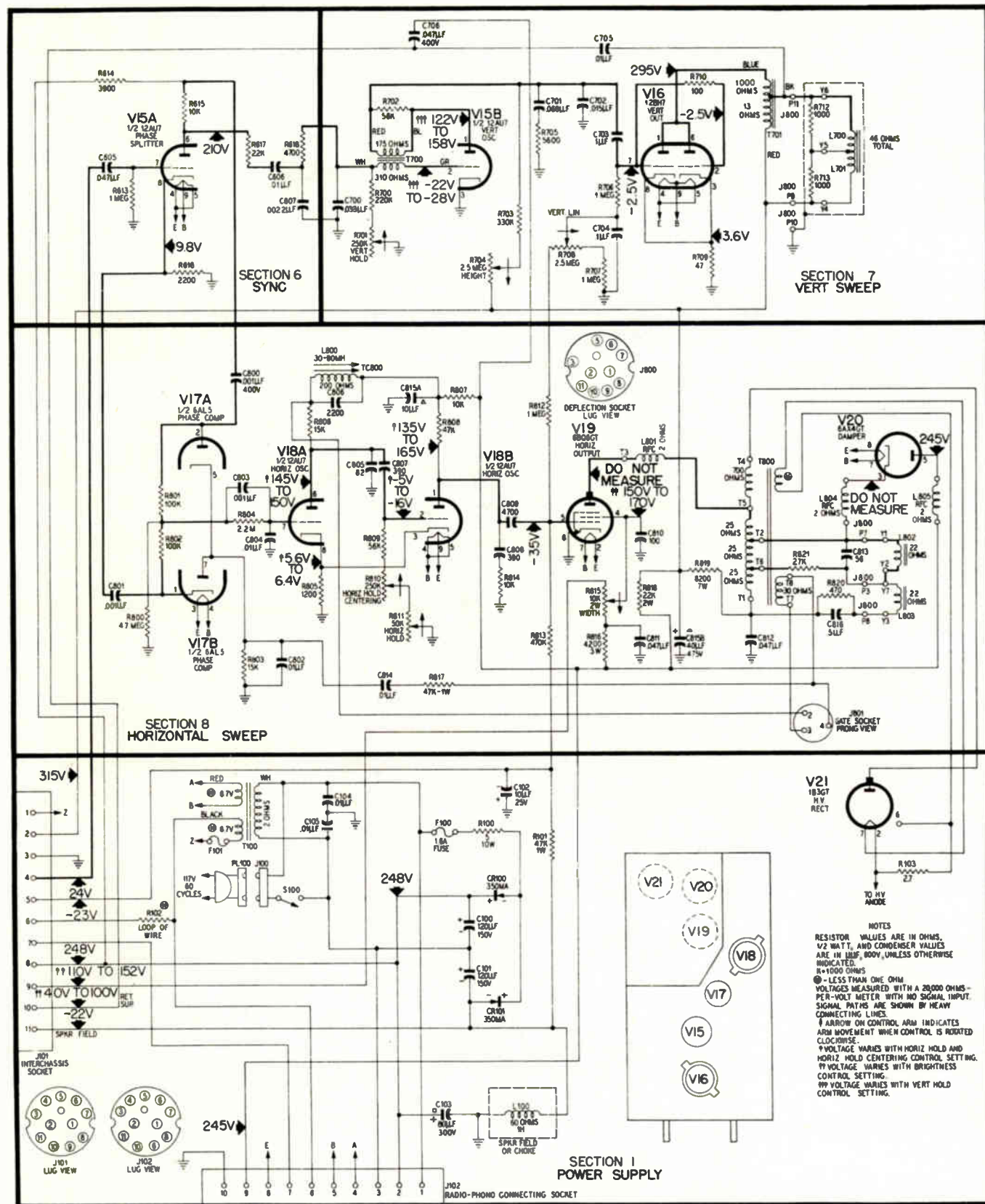

Figure 40. Deflection Chassis J-4, Schematic Diagram

TP2-2248

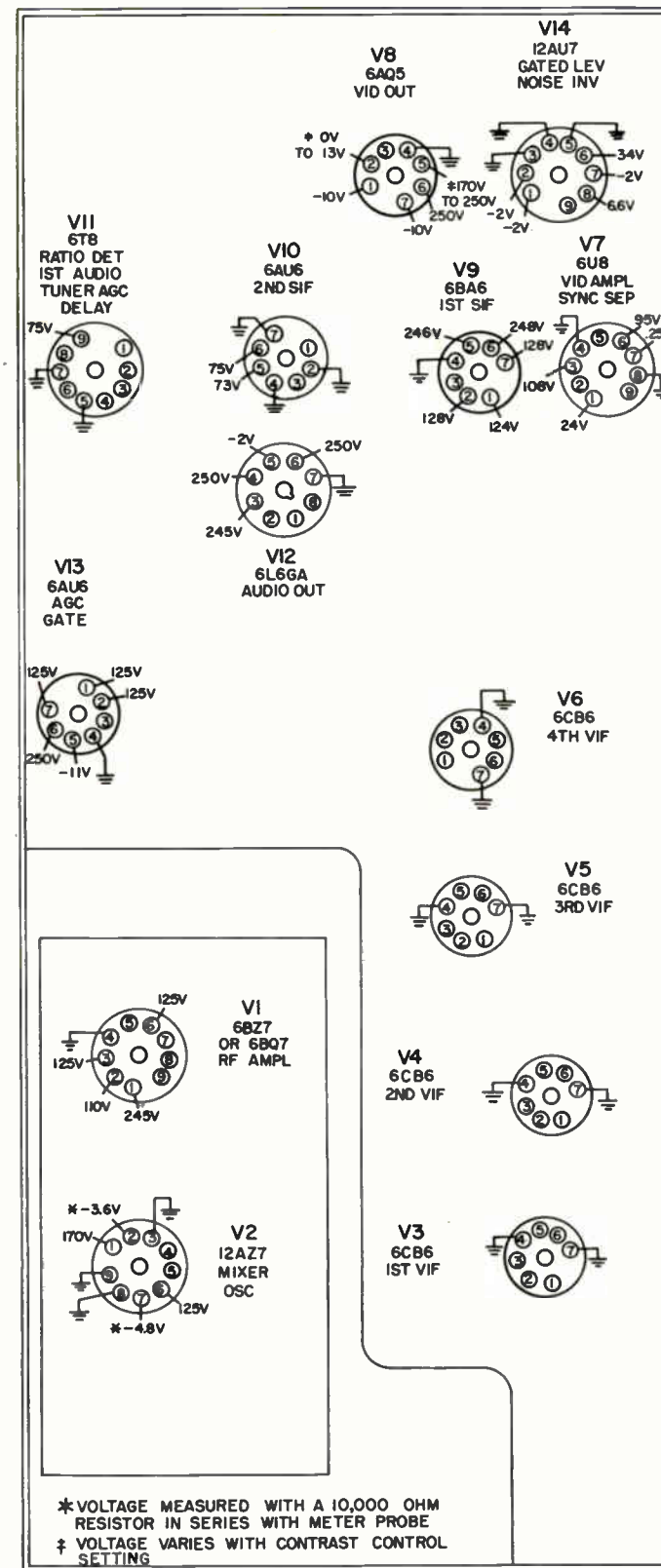

Figure 34. R-F Chassis 94, Bottom View, Showing Voltages at Socket Pins

TP2-2243

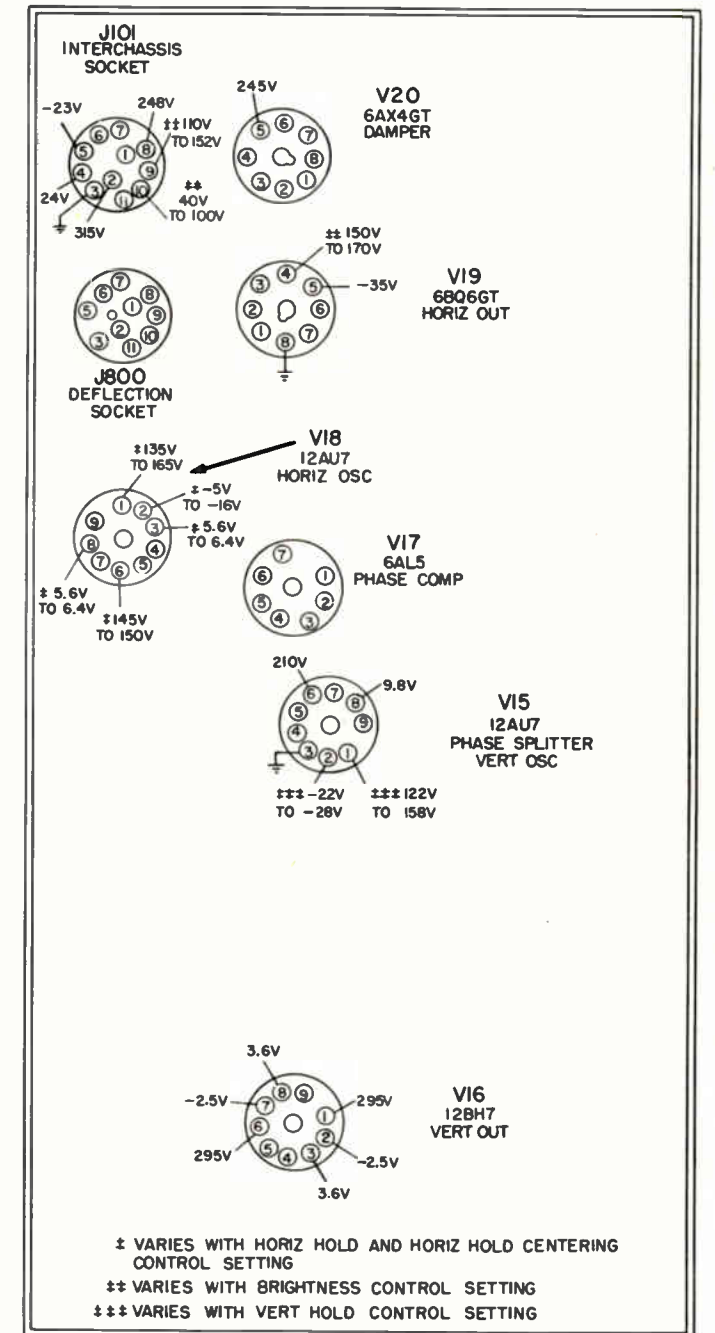

Figure 35. Deflection Chassis J-4, Bottom View, Showing Voltages at Socket Pins

TP2-2244

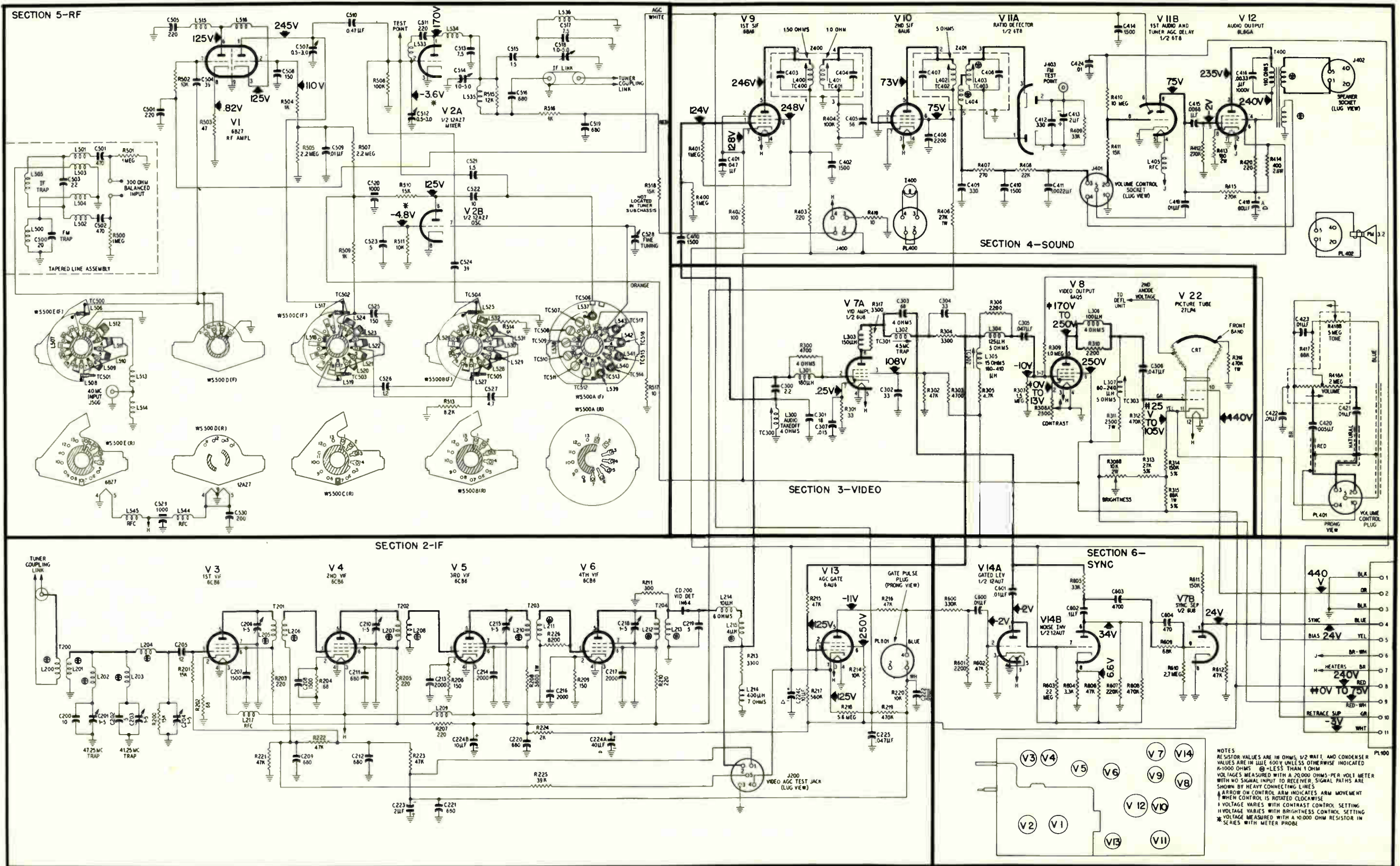

Figure 40. R-F Chassis 97, Schematic Diagram