

# Honeywell



**TERMINALS**

**HARDWARE**

**VIP7200**

**VIDEO DISPLAY  
PRODUCT MANUAL**

This document and the information contained therein is confidential and proprietary to and the exclusive property of Honeywell Information Systems Inc. It is made available only to Honeywell authorized recipients for their use solely in the maintenance and operation of Honeywell products. This document and information must be maintained in strictest confidence; it must not be reproduced in whole or in part; and it shall not be disclosed to any other party without prior written consent of Honeywell.

**HONEYWELL PROPRIETARY AND CONFIDENTIAL**

**HONEYWELL PROPRIETARY AND CONFIDENTIAL**

This document and the information contained therein is confidential and proprietary to and the exclusive property of Honeywell Information Systems Inc. It is made available only to Honeywell authorized recipients for their use solely in the maintenance and operation of Honeywell products. This document and information must be maintained in strictest confidence; it must not be reproduced in whole or in part; and it shall not be disclosed to any other party without prior written consent of Honeywell.

VIP7200 VIDEO

DISPLAY TERMINAL PRODUCT MANUAL

Document No. 71010513-201      Order No. FN66, Rev. 1

This manual has been reprinted to include change-page package -201.

**HONEYWELL PROPRIETARY AND CONFIDENTIAL**

HONEYWELL PROPRIETARY AND CONFIDENTIAL

RECORD OF REVISIONS

| REVISION | DATE       | AUTHORITY   | AFFECTED PAGES   |
|----------|------------|---|--|
| -100     | Feb. 1977  | -   | First Issue  |
| -101     | Aug. 1977  | BLC070863   | Title, ROR, iii, vii,<br>2-6 thru 2-8, 9-1<br>thru 9-5, 11-1, and<br>11-36 thru 11-50                                      |
| -200     | Sept. 1977 | BLCOs 70272,<br>70440, and 70585  | Entire manual  |
| -201     | Nov. 1977  | BLC070214,<br>BLC070325,<br>BLC070500,<br>BLC070822,<br>BLC070833, and<br>BLC071069 | Title, ROR, 2-6, 2-7,<br>9-5, 10-2 thru 10-10,<br>10-25 thru 10-36,<br>11-10 thru 11-24,<br>11-31, and 11-35 thru<br>11-54 |
| -201     | Feb. 1978  | Reprint   | --   |

Hardware Publications, M&TO, Billerica, MA 01821

Printed in the United States of America  
All rights reserved

0513/FN66

CONTENTS

| Section |  | Page |
|---------|--|------|
| I       | INTRODUCTION                                   | 1-1  |
|         | 1.1 Scope and Purpose of Manual                | 1-1  |
|         | 1.2 General Description                        | 1-2  |
|         | 1.3 Features                                   | 1-3  |
|         | 1.3.1 Keyboard                                 | 1-3  |
|         | 1.3.2 Display                                  | 1-4  |
|         | 1.3.3 Interface                                | 1-4  |
|         | 1.3.4 Options                                  | 1-5  |
|         | 1.4 Specifications                             | 1-5  |
| II      | OPERATING CONTROLS AND PROCEDURES              | 2-1  |
|         | 2.1 Description of Controls and Indicators     | 2-1  |
|         | 2.1.1 Front Panel Controls and Indicators      | 2-1  |
|         | 2.1.2 Operator-Accessible Controls             | 2-1  |
|         | 2.1.3 Internal Switches                        | 2-1  |
|         | 2.1.4 Maintenance Controls and Adjustments     | 2-8  |
|         | 2.2 Operating Guides                           | 2-8  |
|         | 2.2.1 Normal Operation                         | 2-8  |
|         | 2.2.2 Error Conditions                         | 2-9  |
|         | 2.2.3 Local Mode Test Operations               | 2-9  |
| III     | PROGRAMMING                                    | 3-1  |
|         | 3.1 Keyboard Functions                         | 3-1  |
|         | 3.1.1 Alphnumeric Cluster                      | 3-3  |
|         | 3.1.2 Standard Control Function Group          | 3-3  |
|         | 3.1.3 Numeric Pad Group                        | 3-3  |
|         | 3.1.4 Editing Function Group                   | 3-3  |
|         | 3.1.5 Special Control Function Keys            | 3-9  |
|         | 3.1.6 Auxiliary Function Keypad Option         | 3-9  |
|         | 3.2 Keyboard Associated Functions              | 3-9  |
|         | 3.2.1 Transmit Data Function                   | 3-9  |
|         | 3.2.1.1 Transmit Procedure                     | 3-9  |
|         | 3.2.1.2 End of Message Procedure               | 3-12 |
|         | 3.2.2 Roll/Page Mode                           | 3-12 |
|         | 3.2.3 End of Message Key                       | 3-12 |
|         | 3.3 Display Function                           | 3-12 |
|         | 3.3.1 General Display Functions                | 3-12 |
|         | 3.3.2 Response to Single-Character ASCII Codes | 3-14 |

# HONEYWELL PROPRIETARY AND CONFIDENTIAL

## CONTENTS

| Section |       | Page  |      |
|---------|-------|---|------|
|         | 3.3.3 | Response to Two-Character Escape Sequence Codes   | 3-16 |
|         | 3.3.4 | Parity Error in Character Codes                   | 3-18 |
|         | 3.3.5 | Audible Alarm                                     | 3-19 |
|         | 3.3.6 | Special Considerations                            | 3-19 |
| 3.4     |       | Communication Interface                           | 3-19 |
|         | 3.4.1 | EIA Interface                                     | 3-19 |
|         | 3.4.2 | Current Loop Interface                            | 3-19 |
|         | 3.4.3 | Interface Timing and Data Structure               | 3-21 |
|         | 3.4.4 | Communication Procedure                           | 3-21 |
| 3.5     |       | Auxiliary Device Interface                        | 3-21 |
|         | 3.5.1 | Interface Signals                                 | 3-22 |
|         | 3.5.2 | Interface Timing and Data Structure               | 3-23 |
|         | 3.5.3 | Auxiliary Devices                                 | 3-23 |
|         | 3.5.4 | Auxiliary Device Operation                        | 3-23 |
| 3.6     |       | Interface Functionality                           | 3-24 |
|         | 3.6.1 | Remote/Full-Duplex Display Mode                   | 3-24 |
|         | 3.6.2 | Remote/Half-Duplex Display Mode                   | 3-24 |
|         | 3.6.3 | Local Mode  | 3-24 |
| 3.7     |       | Performance                                       | 3-25 |
|         | 3.7.1 | Communication Data Rate                           | 3-25 |
|         | 3.7.2 | CRT Control Functions                             | 3-25 |
|         |       | 3.7.2.1 Time Delay for Erase Functions            | 3-25 |
|         |       | 3.7.2.2 CRT Full Screen Display Times             | 3-25 |
| IV      |       | THEORY OF OPERATION - PRINCIPLES                  | 4-1  |
| V       |       | THEORY OF OPERATION - CYCLE FLOW                  | 5-1  |
| VI      |       | THEORY OF OPERATION - HARDWARE IMPLEMENTATION     | 6-1  |
|         | 6.1   | Clock Function                                    | 6-1  |
|         |       | 6.1.1 Oscillator                                  | 6-5  |
|         |       | 6.1.2 Baud Rate Generator                         | 6-5  |
|         |       | 6.1.3 Power Turn On                               | 6-5  |
|         | 6.2   | Transmit Function                                 | 6-5  |
|         |       | 6.2.1 Keyboard Input                              | 6-6  |
|         |       | 6.2.2 Keyboard Latch                              | 6-6  |
|         |       | 6.2.3 Universal Asynchronous Receiver/Transmitter | 6-6  |
|         |       | 6.2.4 Communication Interface Transmitters        | 6-7  |
|         | 6.3   | Receive Function                                  | 6-7  |
|         |       | 6.3.1 Communication Interface Receivers           | 6-7  |
|         |       | 6.3.2 Universal Asynchronous Receiver/Transmitter | 6-8  |
|         |       | 6.3.3 Character Decoding                          | 6-8  |
|         |       | 6.3.3.1 Control Characters                        | 6-8  |
|         |       | 6.3.3.2 Data Character                            | 6-9  |
|         | 6.4   | Cursor Control Function                           | 6-9  |

# HONEYWELL PROPRIETARY AND CONFIDENTIAL

## CONTENTS

| Section |       | Page  |                                     |  |      |
|---------|-------|---|-------------------------------------|--|------|
|         | 6.4.1 | Cursor Column Counter                       | 6-9                                 |  |      |
|         | 6.4.2 | Cursor Row Counter                          | 6-9                                 |  |      |
|         | 6.4.3 | Cursor Logic                                | 6-10                                |  |      |
| 6.5     |       | Block Control Function                      | 6-10                                |  |      |
|         | 6.5.1 | Page Characterization                       | 6-10                                |  |      |
|         | 6.5.2 | Line Characterization                       | 6-10                                |  |      |
|         | 6.5.3 | End-of-Transmission Character<br>Generation | 6-10                                |  |      |
| 6.6     |       | Display Function                            | 6-10                                |  |      |
|         | 6.6.1 | Random Access Memory                        | 6-12                                |  |      |
|         | 6.6.2 | RAM Addressing                              | 6-12                                |  |      |
|         | 6.6.3 | Dot Counter                                 | 6-13                                |  |      |
|         | 6.6.4 | Column Counter                              | 6-13                                |  |      |
|         | 6.6.5 | Video Line Counter                          | 6-13                                |  |      |
|         | 6.6.6 | Video Row Counter                           | 6-13                                |  |      |
|         | 6.6.7 | Cursor Compare                              | 6-13                                |  |      |
|         | 6.6.8 | Video Generation                            | 6-13                                |  |      |
|         | 6.6.9 | Dual Intensity                              | 6-14                                |  |      |
| 6.7     |       | Auxiliary Device Interface                  | 6-14                                |  |      |
| 6.8     |       | CRT Display                                 | 6-14                                |  |      |
|         | 6.8.1 | Video Amplifier                             | 6-14                                |  |      |
|         | 6.8.2 | Vertical Deflection                         | 6-15                                |  |      |
|         | 6.8.3 | Horizontal Deflection                       | 6-17                                |  |      |
| VII     |       | FAULT DIAGNOSIS                             | 7-1                                 |  |      |
|         | 7.1   | Off-Line Diagnostic Procedures              | 7-1                                 |  |      |
|         |       | 7.1.1                                       | Blank Screen                        | 7-2  |      |
|         |       | 7.1.2                                       | Video Line Control                  | 7-3  |      |
|         |       | 7.1.3                                       | Mini Keyboard Test                  | 7-6  |      |
|         |       | 7.1.4                                       | Keyboard Test (Uppercase)           | 7-7  |      |
|         |       | 7.1.5                                       | Keyboard Test (Upper and Lowercase) | 7-8  |      |
|         |       | 7.1.6                                       | Special Function Test               | 7-10   |      |
|         |       | 7.1.7                                       | Non-Local Test                      | 7-12   |      |
|         |       |   | 7.1.7.1                             | Loopback                                     | 7-12 |
|         |       |   | 7.1.7.2                             | Transmit to Remote<br>Station                | 7-13 |
|         |       |   | 7.1.7.3                             | Receive from Remote<br>Station               | 7-13 |
|         |       | 7.1.8                                       | Auxiliary Device                    | 7-13   |      |
|         |       |   | 7.1.8.1                             | Video Line Control                           | 7-14 |
|         |       |   | 7.1.8.2                             | Mini Keyboard Test                           | 7-16 |
|         |       |   | 7.1.8.3                             | Keyboard Test (Uppercase)                    | 7-16 |
|         |       |   | 7.1.8.4                             | Keyboard Test (Upper and<br>Lowercase)       | 7-16 |
|         |       | 7.1.9                                       | Where To Go From Here               | 7-17   |      |
|         |       | 7.1.10                                      | FER Procedures                      | 7-17   |      |
|         |       |   | 7.1.10.1                            | Isolation of PWAs and<br>CRT Display Chassis | 7-17 |
|         |       |   | 7.1.10.2                            | Isolation of Keyboard<br>and PWAs            | 7-17 |

HONEYWELL PROPRIETARY AND CONFIDENTIAL

| Section |   | Page |
|---------|---|------|
|         | 7.1.10.3 Isolation of Power Supply PWA and Logic PWA          | 7-18 |
|         | 7.1.10.4 Isolation of PWA and Front Panel Lights and Switches | 7-18 |
| 7.2     | Off-Line Auxiliary Device Test                                | 7-20 |
| 7.2.1   | VIP7200/PRU1001 Interaction Test                              | 7-20 |
| 7.2.2   | VIP7200/PRU1003/PRU1005 Interaction Test                      | 7-20 |
| 7.3     | On-Line Diagnostic Procedure                                  | 7-24 |
| 7.4     | VIP7200 Test and Diagnostics Specification                    | 7-24 |
| 7.5     | Test and Verification Instructions                            | 7-24 |
| VIII    | MAINTENANCE   | 8-1  |
| 8.1     | Cover Removal and Replacement                                 | 8-1  |
| 8.2     | Keyboard Replacement  | 8-2  |
| 8.3     | Terminal Logic PWA Replacement                                | 8-2  |
| 8.4     | Power Supply PWA Replacement                                  | 8-3  |
| 8.5     | CRT Display Chassis Replacement                               | 8-3  |
| 8.6     | CRT Display Adjustments                                       | 8-3  |
|         | 8.6.1 Contrast Adjustment                                     | 8-4  |
|         | 8.6.2 Vertical Adjustments                                    | 8-4  |
|         | 8.6.3 Horizontal Adjustment                                   | 8-5  |
|         | 8.6.4 Focus Adjustment  | 8-6  |
|         | 8.6.5 Centering Adjustment                                    | 8-6  |
| 8.7     | Transformer T1 Replacement                                    | 8-6  |
| IX      | INSTALLATION  | 9-1  |
| 9.1     | General   | 9-1  |
| 9.2     | Receiving and Unpacking                                       | 9-1  |
| 9.3     | General Installation Procedure                                | 9-1  |
|         | 9.3.1 Preliminary Installation Data Requirements              | 9-1  |
|         | 9.3.2 Installation  | 9-2  |
| 9.4     | Installation of Auxiliary Devices                             | 9-6  |
|         | 9.4.1 Auxiliary Device Requirements                           | 9-7  |
|         | 9.4.2 Host System Requirements                                | 9-7  |
|         | 9.4.3 Installation  | 9-8  |
| 9.5     | Checkout  | 9-8  |
| X       | ILLUSTRATED PARTS CATALOG                                     | 10-1 |
| XI      | REFERENCE DIAGRAMS  | 11-1 |

HONEYWELL PROPRIETARY AND CONFIDENTIAL

ILLUSTRATIONS

| Figure |  | Page |
|--------|--|------|
| 1-1    | VIP7200 Video Display Terminal                               | 1-2  |
| 1-2    | VIP7200 Video Display Terminal Dimensions                    | 1-6  |
| 2-1    | Front Panel Controls and Indicators                          | 2-2  |
| 2-2    | Operator-Accessible Controls                                 | 2-4  |
| 2-3    | Internal Switches  | 2-6  |
| 3-1    | VIP7200 Keyboard Layout                                      | 3-2  |
| 3-2    | ASCII Code Chart for Keyboard Generated Characters           | 3-4  |
| 3-3    | Keyboard Character Coding Chart                              | 3-5  |
| 3-4    | Keyboard-Generated Two-Character Escape Sequences            | 3-10 |
| 3-5    | Optional Auxiliary Function Keypad Layout                    | 3-11 |
| 3-6    | Received ASCII Codes Recognized by Receive and Display Logic | 3-13 |
| 3-7    | Two-Character Escape Sequence Codes Recognized by Display    | 3-14 |
| 3-8    | Horizontal and Vertical Cursor Position Codes for Px and Py  | 3-18 |
| 3-9    | EIA Primary I/O Communication Interface                      | 3-20 |
| 3-10   | Current Loop Interface Signals                               | 3-20 |
| 3-11   | Auxiliary Interface EIA Signals                              | 3-22 |
| 4-1    | VIP7200 Major Block Diagram                                  | 4-2  |
| 6-1    | VIP7200 Intermediate Block Diagram                           | 6-3  |
| 6-2    | Display Format and Sample Dot Pattern                        | 6-11 |
| 6-3    | CRT Display Block Diagram                                    | 6-15 |
| 6-4    | CRT Display Schematic Diagram                                | 6-19 |
| 7-1    | Power Transformer Voltages                                   | 7-19 |
| 7-2    | VIP7200/PRU1003/PRU1005 Interaction Test                     | 7-23 |
| 8-1    | Location of Contrast Control                                 | 8-4  |
| 8-2    | Location of Adjustments on CRT Circuit Board                 | 8-5  |
| 9-1    | Internal Switches  | 9-5  |

TABLES

| Table |   | Page |
|-------|---|------|
| 2-1   | Front Panel Controls and Indicators             | 2-3  |
| 2-2   | Operator-Accessible Controls                    | 2-5  |
| 2-3   | Internal Switches                               | 2-7  |
| 3-1   | Keyboard Alphanumeric Cluster                   | 3-6  |
| 3-2   | Keyboard Standard Control Function Group        | 3-6  |
| 3-3   | Code Chart for Dual Graphic Keys                | 3-8  |
| 3-4   | Keyboard Editing Function Group                 | 3-9  |
| 3-5   | Response to Single-Character ASCII Codes        | 3-15 |
| 3-6   | Response to Two-Character Escape Sequence Codes | 3-16 |
| 3-7   | Maximum Times for CRT Full Screen Display       | 3-26 |
| 7-1   | Switch Setting and Cable Pair Relationships     | 7-19 |



TABLES

| Table |  | Page |
|-------|--|------|
| 9-1   | Character Structure Configuration      | 9-6  |
| 9-2   | End-of-Message Character Configuration | 9-6  |
| 9-3   | Auxiliary Devices and Cables           | 9-7  |
| 10-1  | VIP7200 Major Assemblies               | 10-2 |

# INTRODUCTION

## 1.1 SCOPE AND PURPOSE OF MANUAL

This manual provides the information necessary for field engineering personnel to install, maintain, and repair the Honeywell VIP7200 video display terminals listed below.

| TYPE    | DESCRIPTION   | PART NO.                              |
|---------|---|---------------------------------------|
| VIP7200 | Terminal, 60-Hz, uppercase<br>Keyboard<br>Cable, W3, 10-foot                  | BTRM901A<br>BKBD002A<br>59B400394-010 |
| VIP7205 | Terminal, 60-Hz, uppercase<br>and lowercase<br>Keyboard<br>Cable, W3, 10-foot | BTRM902A<br>BKBD002A<br>59B400394-010 |
| VIP7250 | Terminal, 50-Hz, uppercase<br>Keyboard<br>Cable, W3, 10-foot                  | BTRM801A<br>BKBD002A<br>59B400394-010 |
| VIP7255 | Terminal, 50-Hz, uppercase<br>and lowercase<br>Keyboard<br>Cable, W3, 10-foot | BTRM802A<br>BKBD002A<br>59B400394-010 |

1.2 GENERAL DESCRIPTION

The VIP7200 Video Display Terminal consists of: (1) a logic and CRT display unit and (2) a separate keyboard unit with an interconnecting ribbon cable (see Figure 1-1). It is a one-at-a-time character mode keyboard entry device capable of block transmission over the communications interface. It can emulate all of the functions of an ASR/KSR33 except for hard copy output; however, an extension port allows auxiliary input and/or output devices (such as a serial printer) to be connected directly to the terminal.

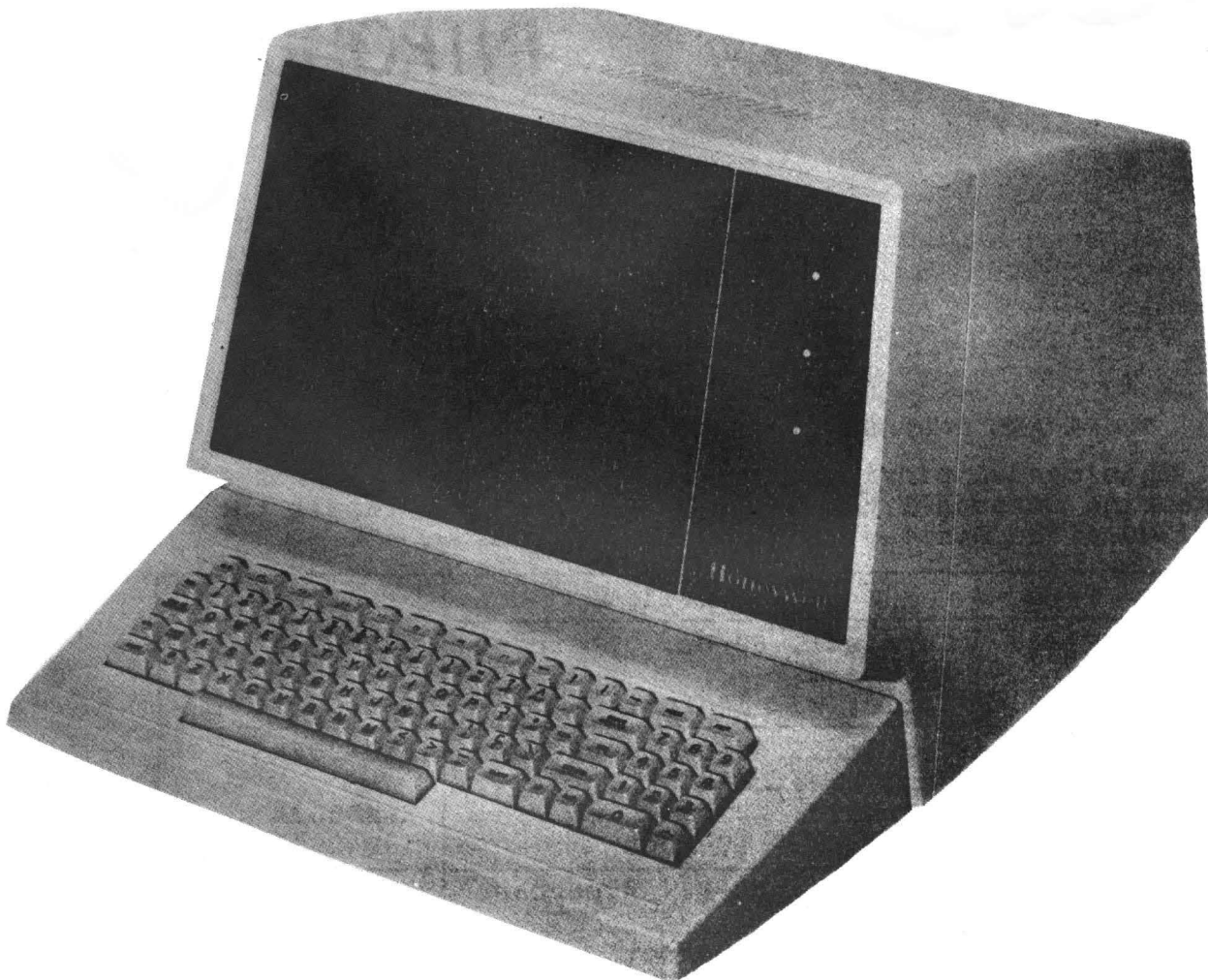

Figure 1-1 VIP7200 Video Display Terminal

The terminal is a top-line entry device with the first position of the top line as the cursor home position. Data is entered in either page or roll mode. In the page mode, data entry is limited to the page displayed on the screen. In the roll mode,

## HONEYWELL PROPRIETARY AND CONFIDENTIAL

the top line rolls off the screen after the page is full, allowing data entry to continue on a new bottom line. Full cursor control allows data entry at any location on the page.

The terminal has a four-wire, full-duplex interface capable of two-way simultaneous or two-way alternate data transfer using either 20-mA/60-mA current loop or EIA RS232C voltage levels on the interface leads. It can operate with Western Electric modems 103A, 103E, 103G (or equivalent full-duplex modems not requiring control of interface leads or line turnarounds), and Western Electric modems 202C and 202D (or equivalent half-duplex modems requiring control of interface leads or line turnarounds).

All 128 ASCII character codes can be generated from the keyboard. The terminal buffers and transmits a single keyed character in character mode, or a line or page (up to the cursor location) in the line or page mode. Special code sequences using escape and another keyboard character will generate special codes for non-ASR/KSR33 functions.

Start, parity, and stop bits are added to each character before it is transmitted. The number of stop bits can be selected at either one or two, and parity can be selected to add an odd bit, an even bit or a mark bit. Thus, in combination with the 7-bit ASCII code, either 10- or 11-bit characters can be transmitted and received. When the mark bit parity setting is selected for the transmitted data, the parity testing on received data is simultaneously set to a 'don't care' condition.

The terminal operates at switch selectable baud rates between 75 and 9600 baud when direct connected, and at the modem limitation of up to 1200 baud when connected to a modem.

### CAUTION

When the terminal is set for 110 or 75 baud, repeated keying of a cursor movement key (without using REPEAT) could result in the display of extraneous characters on the screen instead of the intended cursor movement.

## 1.3 FEATURES

### 1.3.1 Keyboard

The keyboard characteristics consist of:

- ASCII code (128 characters) on an 86-key communications keyboard
- Extended capability via escape sequence coding
- Seven dual-coded special function keys
- N-key rollover protection.

### 1.3.2 Display

Display unit characteristics include:

- Screen display area of 54 square inches
- Total of 1920 characters displayed in 24 lines of 80 characters each
- Total of 63 displayable graphic characters plus space
- Top line entry; cursor homes at left margin of top line
- Full cursor control
- Automatic carriage return/line feed
- Audible alarm upon entry of keyed data in column 72
- Buffered line or page with local edit via keyboard
- Page or roll mode of operation
- Parity check and display of ? on recognition of error
- Line turnaround control for half-duplex communication data sets.

### 1.3.3 Interface

The VIP7200 Video Display unit has the following interface capabilities.

1. Selectable communications interface: EIA RS232C or 20-mA/60-mA current loop.
2. Selectable baud rate: 75 to 9600 baud.
3. Selectable character length: 10 bits (start, 7 data, parity, and stop) or 11 bits (start, 7 data, parity, and 2 stop).
4. Selectable parity: odd, even, or no parity (always a mark on transmit and 'don't care' on receive).
5. Selectable operating mode:
  - a. Full-duplex, no local display: full-duplex echoplex mode of operation for displaying keyed data on screen.
  - b. Full-duplex, local display: full-duplex capability with display responding directly to keyboard (no echoplex) and/or to received data.
  - c. Half-duplex: two-way alternate capability with line turnaround and display responding directly to keyboard and/or to received data.
  - d. Half-duplex, buffered mode: keyed data transmitted only by special block mode character; display responds directly to keyboard and/or to received data.
  - e. Local display: keyed data displayed directly on screen for test purposes; no transmission of data over communication line.

## HONEYWELL PROPRIETARY AND CONFIDENTIAL

6. Extensions port for auxiliary input/output device: limited EIA interface works in combination with and through communications interface.

### 1.3.4 Options

Two options are available with the terminal: 31 displayable lowercase graphic characters and an 18-key auxiliary special function keypad.

### 1.4 SPECIFICATIONS

VIP7200 specifications consist of the following.

1. Environmental:
  - a. Temperature: 10°C to 38°C ambient (50°F to 100°F)
  - b. Relative Humidity: 10% to 80%
  - c. Suitable for use in Honeywell class 2 environment.
2. Electrical:
  - a. Voltage (60 Hz ±0.5 Hz): 120 Vac +10%, -15%, 1 A
  - b. Voltage (50 Hz ±0.5 Hz): 220 Vac +6%, -15%, or 240 Vac +6%, -15%, 0.0175 A
3. Mechanical:
  - a. Dimensions: See Figure 1-2
  - b. Weight: Approximately 50 pounds (22.68 kilograms).

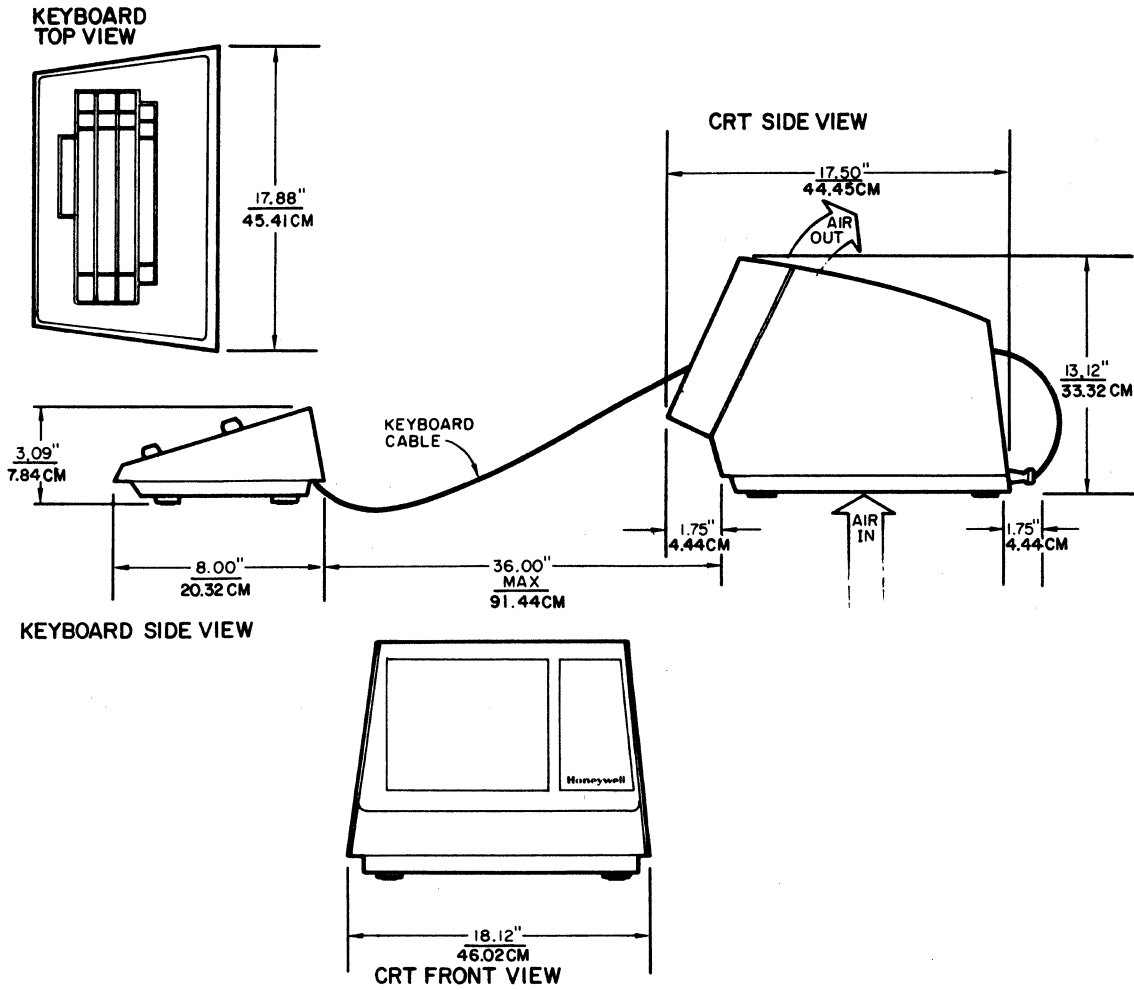

Figure 1-2 VIP7200 Video Display Terminal Dimensions

# II OPERATING CONTROLS AND PROCEDURES

This section identifies and describes all operating controls and internal switches used for operating and configuring the terminal. It also contains guidelines for normal operation, error recognition, and general testing.

## 2.1 DESCRIPTION OF CONTROLS AND INDICATORS

### 2.1.1 Front Panel Controls and Indicators

Three switches and three indicators are located on the front panel to the right of the screen. They are shown in Figure 2-1 and described in Table 2-1.

### 2.1.2 Operator-Accessible Controls

The operator-accessible controls on the back of the terminal are identified in Figure 2-2. The functions of these controls are described in Table 2-2.

### 2.1.3 Internal Switches

The internal switches are shown in Figure 2-3 and described in Table 2-3. These switches are normally set at the factory or by the installing FER when configuring the terminal to be compatible with the host system. Refer to Section IX Installation for further information on these switches.



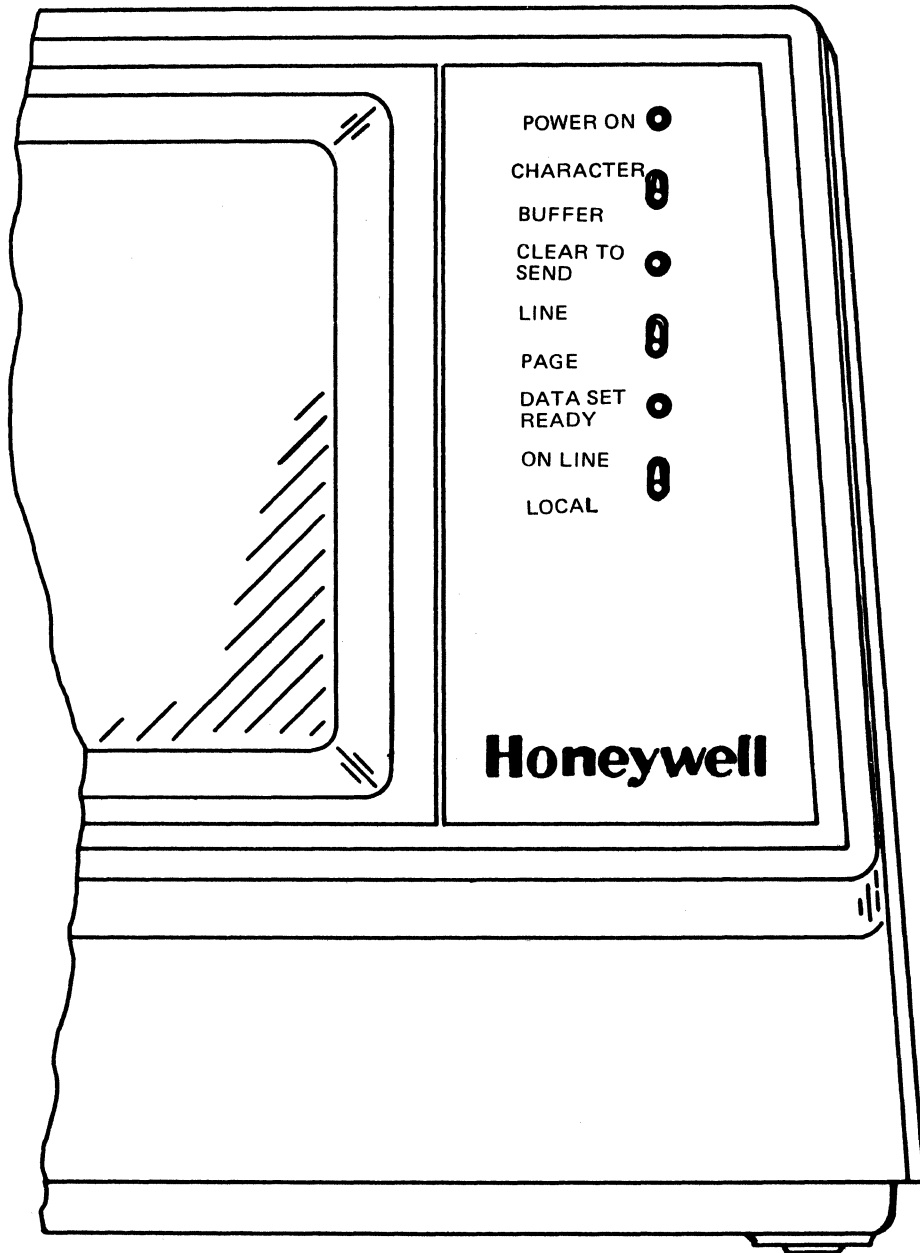

Figure 2-1 Front Panel Controls and Indicators

**HONEYWELL PROPRIETARY AND CONFIDENTIAL**

Table 2-1 Front Panel Controls and Indicators

| CONTROL/INDICATOR        | FUNCTION  |
|--------------------------|---|
| POWER ON indicator       | Illuminates when power switch is on and dc power is present.  |
| CHARACTER/BUFFER switch  | In CHARACTER position, allows terminal to transmit characters as they are keyed. In BUFFER position, keyed data is displayed but not transmitted until the TRANSMIT key initiates a block mode transmission. See NOTE.                    |
| CLEAR TO SEND indicator  | Illuminates when interface signal CB (Clear to Send) is on.   |
| LINE/PAGE switch         | Selects line or page for block mode transmission. Transmission starts at beginning of line or page and continues to cursor position.  |
| DATA SET READY indicator | Illuminates when interface signal CC (Data Set Ready) is on, indicating that a communication link has been established.   |
| ON LINE/LOCAL switch     | Controls interface signal CD (Data Terminal Ready). In ON LINE position, CD is on and terminal is capable of data communication. In LOCAL position, a mask is placed on the line. Terminal may be used for testing or training. See NOTE. |

NOTE

Local COPY switch must be in LOCAL COPY position.

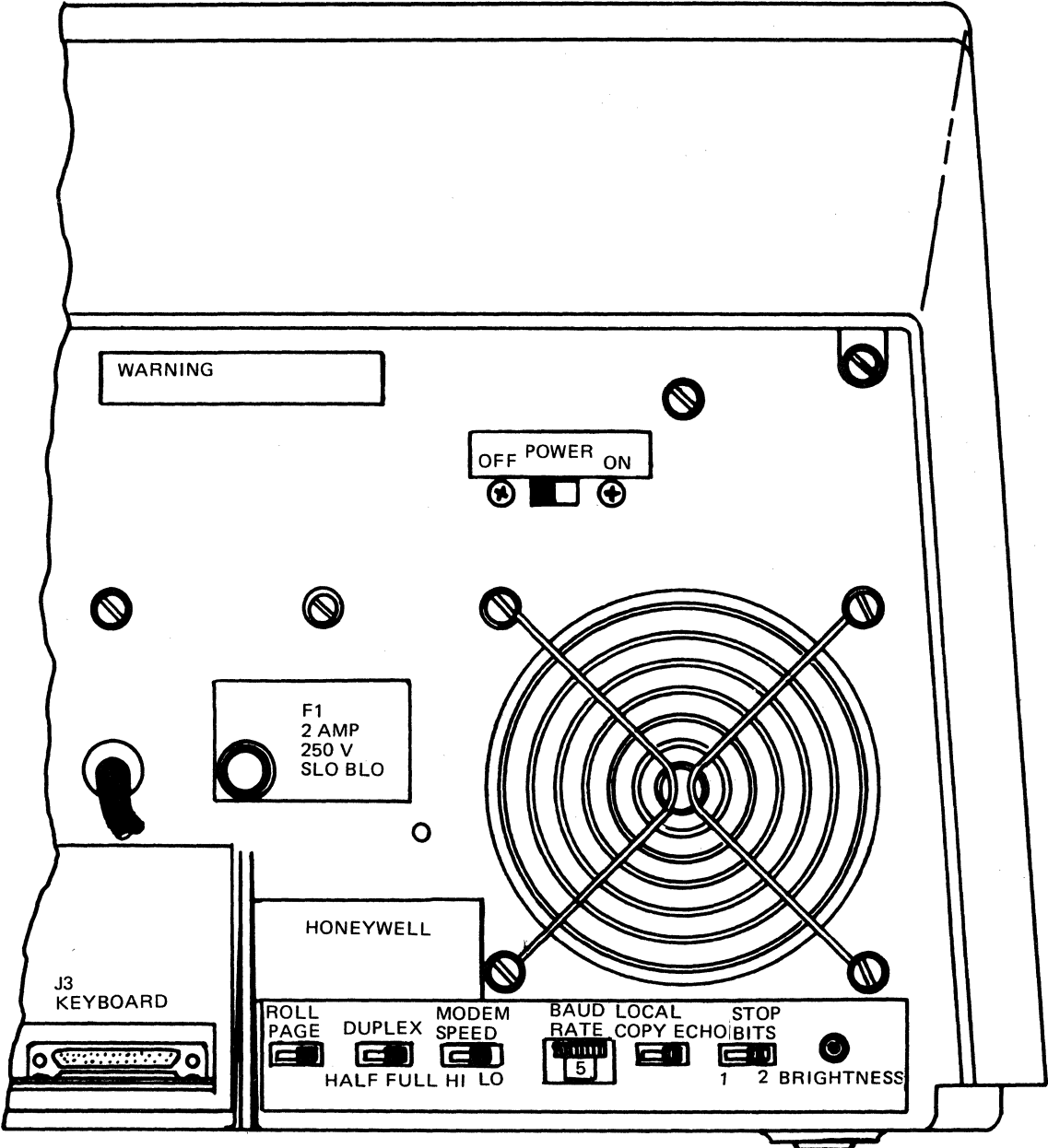
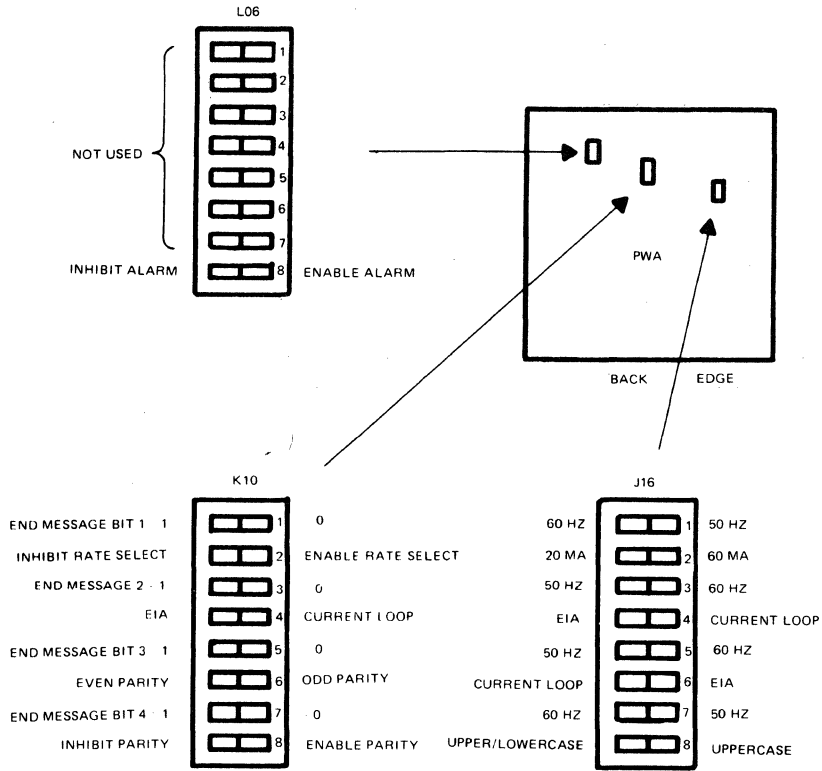

Figure 2-2 Operator-Accessible Controls

**HONEYWELL PROPRIETARY AND CONFIDENTIAL**

Table 2-2 Operator-Accessible Controls

| CONTROL           | FUNCTION  |
|-------------------|---|
| POWER OFF/ON      | Controls application of ac power to terminal.   |
| ROLL/PAGE         | In ROLL position, allows continuous data entry. When page is full, top line rolls off page to provide blank bottom line. In PAGE position, data entry is limited to page (24 lines).    |
| HALF/FULL DUPLEX  | In FULL position, CA (Request to Send) is in high state. In HALF position, CA is controlled for half-duplex line protocol and CB is the signal for line turnaround completion.          |
| HI/LO MODEM SPEED | In conjunction with internal rate select switch, indicates 1200- or 600-baud operation to modem. Must be set appropriately for European/UK applications.                                |
| BAUD RATE         | Permits selection of communication interface baud rate from 75 to 9600 baud.  |
| LOCAL COPY/ECHO   | In LOCAL COPY position, keyed data is displayed simultaneously with its transmission to host system. In ECHO position, display receives signal from communication interface (echoplex). |
| 1/2 STOP BITS     | Permits selection of either 1 or 2 stop bits per character.   |
| BRIGHTNESS        | Adjusts intensity of display.   |



a. PWA 60130705

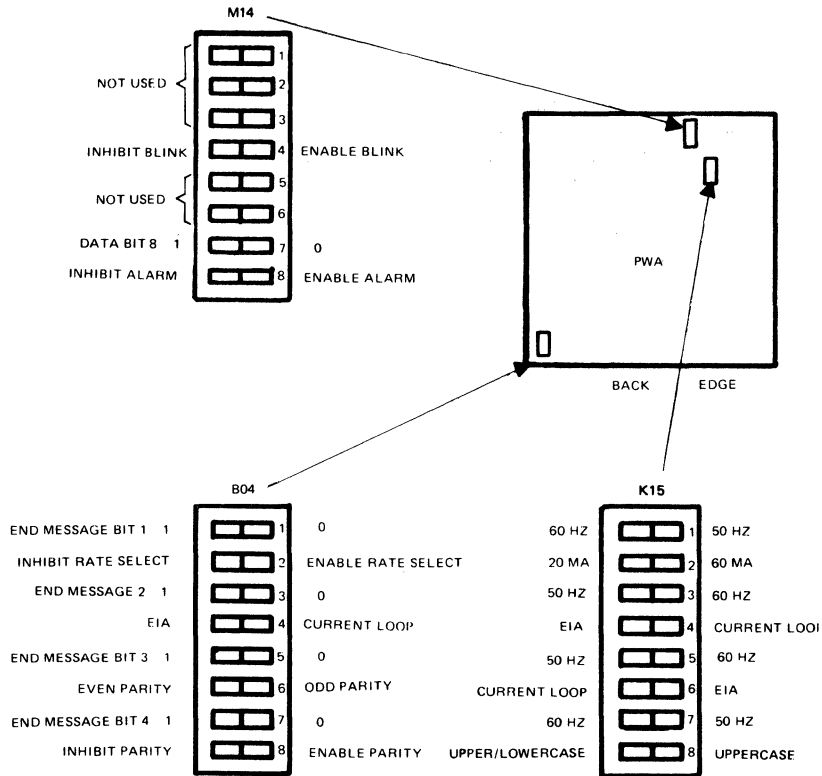

b. PWA 60130734

Figure 2-3 Internal Switches

**HONEYWELL PROPRIETARY AND CONFIDENTIAL**

Table 2-3 Internal Switches

| SWITCH   | FUNCTION   |
|--|--|
| <p><u>Locations L06/M14*</u></p> <p>Audible Alarm</p> <p>Inhibit/Enable Blink</p> <p>Data Bit 8 = 1/0</p>  | <p>In inhibit position, alarm sounds only on receipt of BEL code.</p> <p>In Inhibit position, the cursor does not blink.</p> <p>Data Bit 8 = 1 indicates that an 8-bit ASCII code is sent to the controller. Data Bit 8 = 0 indicates that a 7-bit ASCII code is sent to the controller.</p>   |
| <p><u>Locations K10/B04*</u></p> <p>End of Message Bits (4 switches)</p> <p>Inhibit/Enable Data Signaling Rate</p> <p>Even/Odd Parity</p> <p>Inhibit/Enable Parity</p> <p>EIA/Current Loop</p> | <p>Selects CR, ETX, or EOT as ending character for block mode transmissions by establishing first 4 bits of character.</p> <p>Routes appropriate level to interface when required for European/UK applications.</p> <p>Selects even or odd parity in I/O character format.</p> <p>Allows inhibiting or enabling or parity bit in I/O character format.</p> <p>Selects EIA RS232C or current loop interface.</p>                              |
| <p><u>Locations J16/K15*</u></p> <p>60 Hz/50 Hz (4 switches)</p> <p>EIA/Current Loop (2 switches)</p> <p>20 mA/60 mA</p> <p>Uppercase and Uppercase/Lowercase</p>                              | <p>Selects CRT scan rate to correspond with line frequency of terminal.</p> <p>Selects EIA RS232C or current loop as the communication interface.</p> <p>Selects 20 or 60 mA for current loop interface.</p> <p>In the uppercase and lowercase position, enables lowercase display function if terminal is equipped with this option. In uppercase position, received lowercase characters are displayed as their uppercase equivalents.</p> |

\*L06, K10, and J16 are used with PWA 60130705. M14, B04, and K15 are used with PWA 60130734.

#### 2.1.4 Maintenance Controls and Adjustments

The maintenance controls located inside the enclosure and their adjustments are described in Section VIII Maintenance. Adjustment of these controls is normally required only when repairs are necessary.

### 2.2 OPERATING GUIDES

#### 2.2.1 Normal Operation

When the terminal has been properly installed as directed in Section IX of this manual, placing the POWER switch in the ON position causes the POWER ON indicator to light and the cursor to appear on the screen. The cursor is a reverse video, block that appears in the home position (first column, top line of display). As data is keyed in, any character written in column 80 moves the cursor into a nonexistent column (i.e., outside the data display area). The next character written causes an automatic carriage return/line feed with the character appearing in the first column of the next line and the cursor in column 2.

The cursor movement keys (←, ↑, →, and ↓) move the cursor one character space in the direction indicated. The HOME key moves the cursor directly to the home position. When used in conjunction with the repeat (RPT) key, the cursor moves at the rate of 15 character spaces per second until the repeat key is released.

The carriage return (CR) code from the host on the keyboard RETURN key moves the cursor to column 1 of the line it is in. There is no automatic line feed with a carriage return.

Each line feed (LF) code moves the cursor down the display one line without changing its column position. If the display is in the roll mode, a line feed issued with the cursor in line 24 rolls the entire display up one line (the top line being lost). If the display is in the page mode with the cursor in line 24, the line feed code is ignored.

All keyboard entered characters (see Figure 3-1) are encoded except for break (BRK) and END OF MESSAGE which are dc level output keys. The code generated is controlled by the alternate action CAP LOCK key. With the CAP LOCK key released, depressing any key by itself generates the code for the lowercase character or symbol. Any key used in conjunction with the SHIFT key generates the uppercase character or symbol code. The CAP LOCK key sets the keyboard in the uppercase only mode, preventing lowercase characters from being displayed. However, the SHIFT key can still be used to select the appropriate uppercase or lowercase symbol for numeric and symbol keys.

Depressing the control (CTL) key with an alphabetic key generates a control character. For example, CTL depressed along with G generates the BEL code; CTL depressed with [ generates the escape (ESC) code which, when followed by SHIFT depressed with the A key, moves the cursor up one line (the same as for the ↑ key code - see Table 3-4).

The break (BRK) key allows the operator to halt or break processing, displaying, or printing. This key generates an open line (spacing or all-Zeros condition) for 130 milliseconds.

## HONEYWELL PROPRIETARY AND CONFIDENTIAL

The escape (ESC) and delete (DEL) keys generate their respective ASCII codes when depressed.

The separate numeric group keys generate their respective codes independent of the SHIFT and CAP LOCK keys. If depressed in conjunction with the control (CTL) key, no output code is generated.

The END OF MESSAGE key is used in half-duplex character mode communication to indicate the end of a message and to turn the communication line around to allow the terminal to receive data from the host.

The clear (CLR) code clears the screen and returns the cursor to its home position.

The ERASE EOP/EOL key is used in conjunction with the SHIFT key. When depressed with the SHIFT key released, the display is erased from the cursor position to the end of the line. With the SHIFT key also depressed, the display is erased from the cursor to the end of the page.

The transmit (XMIT) key is used for line or page buffered mode operation. In the line buffered mode, this code instructs the display to transmit the line containing the cursor up to but not including the cursor position. In the page buffered mode, transmission starts at the home position and proceeds up to the cursor position. In both cases, the keyboard is not connected to the communication line but to the display.

The seven special function keys, F1 through F7, are host dependent. They are used for application programming and are user-defined.

An audible alarm is provided as an operator warning. It sounds when a character is keyed after displaying the 71st character in a line or when the BEL code is received. An internal switch can be used to disable the keyed-character end-of-line warning to the operator.

### 2.2.2 Error Conditions

The terminal will display parity errors received over the communication line by substituting a ? for the faulty character. Any other malfunctions will be exhibited as a loss of displayed video, improper response to keyboard entries, etc.

### 2.2.3 Local Mode Test Operations

The ON LINE/LOCAL switch on the front panel allows the terminal to be isolated from the host system for test purposes. It may also be used for editing where communication procedures allow devices to drop out and return. In the local mode, the keyboard is connected to the display and the communication line is locked out. See Section VII for testing procedures.

#### NOTE

The LOCAL COPY switch must be in the LOCAL COPY position.



# III PROGRAMMING

This section describes the interface and functional operations between the terminal and a host system, and between the terminal and an auxiliary input/output device.

In general, the terminal functions as an ASR/KSR33, but without hard copy capability (except through the extension port). For such applications, it can be configured to be directly compatible with standard TTY software support (refer to Section IX Installation). However, for other applications some additional features may be enabled which require additional software in order to function properly.

## NOTE

All alphanumeric codes referred to in this section are represented in hexadecimal.

The following areas are described in this section: keyboard functions, keyboard associated functions, display functions, communication interface, auxiliary device interface, interface functionality, and performance.

### 3.1 KEYBOARD FUNCTIONS

The keyboard layout and keytop legends are shown in Figure 3-1. In normal mode, the keyboard is capable of generating the full 128 seven-bit ASCII character set plus selected 8-bit codes.

Figure 3-1 VIP7200 Keyboard Layout

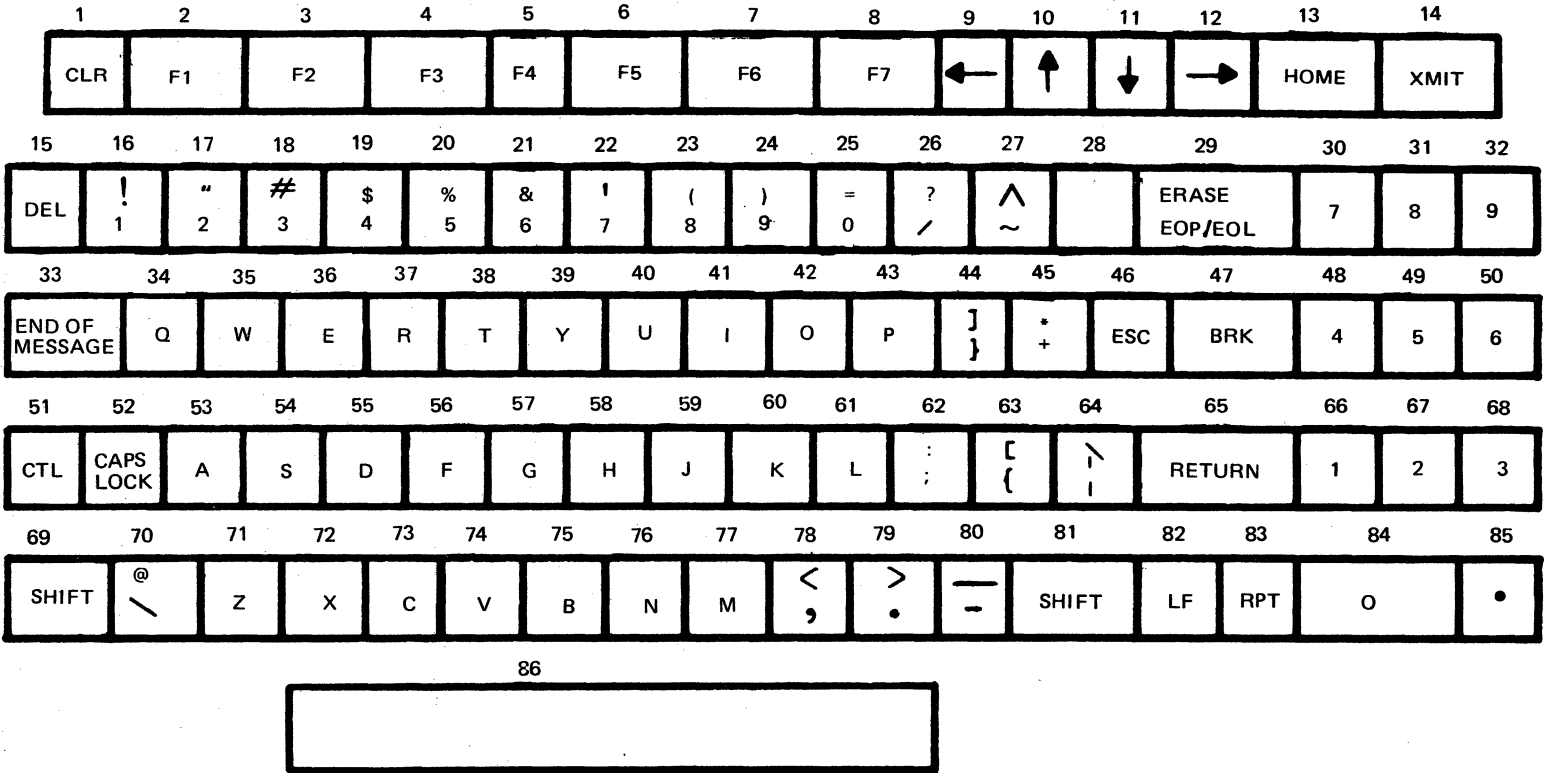

## HONEYWELL PROPRIETARY AND CONFIDENTIAL

The keyboard is divided into the following functional groups.

- Alphanumeric cluster (48 keys)
- Standard control function group (12 keys)
- Numeric pad group (11 keys)
- Editing function group (8 keys)
- Special control function keys (7 keys)
- Auxiliary function keypad option (18 keys).

### 3.1.1 Alphanumeric Cluster

The 48-key alphanumeric cluster consists of 26 alphabetic keys, 10 combination numeric and graphic keys, 11 dual graphic keys, and a space key. With these keys, in combination with the control function key, it is possible to generate the full 128-character, seven-bit ASCII code set shown in Figure 3-2 or the 128-character eight-bit ASCII code set shown in Figure 3-3. The keys in the alphanumeric cluster are described in Table 3-1.

### 3.1.2 Standard Control Function Group

The 12 keys of the standard control function group are described in Table 3-2.

### 3.1.3 Numeric Pad Group

The 11-key numeric pad group consists of keys 0 through 9 and the decimal point (period). When depressed, these keys generate ASCII codes 3/0 through 3/9 and 2/E, as appropriate (independent of the SHIFT and CAP LOCK keys). If depressed in combination with the CTL key, no output is generated.

### 3.1.4 Editing Function Group

The eight keys in the editing function group provide editing capabilities including cursor position and erase modes. Except for the ERASE EOL/EOP (which operates with the SHIFT key), these keys are independent of the SHIFT, CAP LOCK, and CTL keys. The output codes generated consist of the two-character escape sequences given in Table 3-4.

HONEYWELL PROPRIETARY AND CONFIDENTIAL

| BITS           |                |                |                |                | 0 0            | 0 0 1            | 0 1 0  | 0 1 1 | 1 0 0 | 1 0 1 | 1 1 0 | 1 1 1 |   |   |     |   |   |   |   |   |
|----------------|----------------|----------------|----------------|----------------|----------------|------------------|--------|-------|-------|-------|-------|-------|---|---|-----|---|---|---|---|---|
| b <sub>7</sub> | b <sub>6</sub> | b <sub>5</sub> | b <sub>4</sub> | b <sub>3</sub> | b <sub>2</sub> | b <sub>1</sub> * | COLUMN | 0     | 1     | 2     | 3     | 4     | 5 | 6 | 7   |   |   |   |   |   |
| ROW            |                |                |                |                | 0              | 1                | 2      | 3     | 4     | 5     | 6     | 7     | 8 | 9 | A   | B | C | D | E | F |
| 0              | 0              | 0              | 0              | 0              | 0              | 0                |        | NUL   | DLE   | SP    | 0     | @     | P | ' | p   |   |   |   |   |   |
| 0              | 0              | 0              | 0              | 1              | 1              | 0                |        | SOH   | DC1   | !     | 1     | A     | Q | a | q   |   |   |   |   |   |
| 0              | 0              | 0              | 1              | 0              | 2              | 0                |        | STX   | DC2   | "     | 2     | B     | R | b | r   |   |   |   |   |   |
| 0              | 0              | 0              | 1              | 1              | 3              | 0                |        | ETX   | DC3   | #     | 3     | C     | S | c | s   |   |   |   |   |   |
| 0              | 0              | 1              | 0              | 0              | 4              | 0                |        | EOT   | DC4   | \$    | 4     | D     | T | d | t   |   |   |   |   |   |
| 0              | 0              | 1              | 0              | 1              | 5              | 0                |        | ENQ   | NAK   | %     | 5     | E     | U | e | u   |   |   |   |   |   |
| 0              | 0              | 1              | 1              | 0              | 6              | 0                |        | ACK   | SYN   | &     | 6     | F     | V | f | v   |   |   |   |   |   |
| 0              | 0              | 1              | 1              | 1              | 7              | 0                |        | BEL   | ETB   | '     | 7     | G     | W | g | w   |   |   |   |   |   |
| 0              | 1              | 0              | 0              | 0              | 8              | 0                |        | BS    | CAN   | (     | 8     | H     | X | h | x   |   |   |   |   |   |
| 0              | 1              | 0              | 0              | 1              | 9              | 0                |        | HT    | EM    | )     | 9     | I     | Y | i | y   |   |   |   |   |   |
| 0              | 1              | 0              | 1              | 0              | A              | 0                |        | LF    | SUB   | *     | :     | J     | Z | j | z   |   |   |   |   |   |
| 0              | 1              | 0              | 1              | 1              | B              | 0                |        | VT    | ESC   | +     | ;     | K     | [ | k | {   |   |   |   |   |   |
| 0              | 1              | 1              | 0              | 0              | C              | 0                |        | FF    | FS    | ,     | <     | L     | \ | l | !   |   |   |   |   |   |
| 0              | 1              | 1              | 0              | 1              | D              | 0                |        | CR    | GS    | -     | =     | M     | ] | m | }   |   |   |   |   |   |
| 0              | 1              | 1              | 1              | 0              | E              | 0                |        | SO    | RS    | .     | >     | N     | ^ | n | ~   |   |   |   |   |   |
| 0              | 1              | 1              | 1              | 1              | F              | 0                |        | SI    | US    | /     | ?     | O     | _ | o | DEL |   |   |   |   |   |

\*b<sub>1</sub> IS LOW-ORDER BIT.

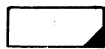

Code produced by first depressing and holding the CTL key, then the corresponding key in columns 4, 5, 6, 7 (except for DEL). Action of the CTL key is to force bits 6 and 7 to zero. Example: CTL, then a (or A) produces the output code for SOH. Note: Depressing CTL, then any key in column 2 or 3 produces either no output or the NUL code.

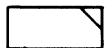

Code produced as a result of depressing a single key as marked on the keyboard. Where dual markings are indicated, code for the character shown on the lower portion of the key is produced.

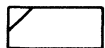

Code produced by first depressing and holding SHIFT key, then depressing appropriately marked key. Where dual markings are indicated, code for the character shown on the upper portion of the key is produced.

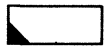

When CAPS LOCK key is depressed and locked, these character codes are inhibited. The associated keys will always produce the uppercase equivalent code as if the SHIFT key were activated, regardless of the actual position of the SHIFT key. Note: CAPS LOCK is not a SHIFT lock since only the characters indicated are affected.

Figure 3-2 ASCII Code Chart for Keyboard Generated Characters

|                |                |                |                |                | b <sub>8</sub> = 0 |     |     |     |     |     |     |     | b <sub>8</sub> = 1 |                    |                    |     |     |       |     |      |   |
|----------------|----------------|----------------|----------------|----------------|--------------------|-----|-----|-----|-----|-----|-----|-----|--------------------|--------------------|--------------------|-----|-----|-------|-----|------|---|
|                |                |                |                |                | 0 0                | 0 0 | 0 1 | 0 1 | 1 0 | 1 0 | 1 1 | 1 1 | 0 0                | 0 0                | 0 1                | 0 1 | 1 0 | 1 0   | 1 1 | 1 1  |   |
| Bits           |                |                |                |                | COLUMN             | 0   | 1   | 2   | 3   | 4   | 5   | 6   | 7                  | 8                  | 9                  | A   | B   | C     | D   | E    | F |
| b <sub>7</sub> | b <sub>6</sub> | b <sub>5</sub> | b <sub>4</sub> | b <sub>3</sub> | ROW                | 0   | 1   | 2   | 3   | 4   | 5   | 6   | 7                  | 8                  | 9                  | A   | B   | C     | D   | E    | F |
| 0              | 0              | 0              | 0              | 0              | 0                  | NUL | DLE | SP  | 0   | @   | P   | `   | ~                  |                    |                    |     |     | C(N0) | F0  | C(0) |   |
| 0              | 0              | 0              | 0              | 1              | 1                  | SOH | DC1 | !   | 1   | A   | Q   | a   | q                  | TAB (SET)          | TAB (CLR)          |     |     | C(N7) | F1  | C(1) |   |
| 0              | 0              | 0              | 1              | 0              | 2                  | STX | DC2 | "   | 2   | B   | R   | b   | r                  | CLEAR (EOL)        | CLEAR (EOP)        |     |     | C(N4) | F2  | C(2) |   |
| 0              | 0              | 1              | 1              | 1              | 3                  | ETX | DC3 | #   | 3   | C   | S   | c   | s                  | CHAR (INS)         | CHAR (DEL)         |     |     | C(N1) | F3  | C(3) |   |
| 0              | 1              | 0              | 0              | 0              | 4                  | EOT | DC4 | \$  | 4   | D   | T   | d   | t                  | LINE (INS)         | LINE (DEL)         |     |     | C(N8) | F4  | C(4) |   |
| 0              | 1              | 0              | 1              | 1              | 5                  | ENQ | NAK | %   | 5   | E   | U   | e   | u                  | TRANS (MSG)        | TRANS (PAGE)       |     |     | C(N5) | F5  | C(5) |   |
| 0              | 1              | 1              | 0              | 0              | 6                  | ACK | SYN | &   | 6   | F   | V   | f   | v                  | OFF LINE PRT (VAR) | ON LINE PRT (FORM) |     |     | C(N2) | F6  | C(6) |   |
| 0              | 1              | 1              | 1              | 1              | 7                  | BEL | ETB | '   | 7   | G   | W   | g   | w                  | ←                  | →                  |     |     | C(N9) | F7  | C(7) |   |
| 1              | 0              | 0              | 0              | 0              | 8                  | BS  | CAN | (   | 0   | H   | X   | h   | x                  | ←                  | →                  |     |     | C(N6) | F8  | C(8) |   |
| 1              | 0              | 0              | 1              | 1              | 9                  | HT  | EM  | )   | 9   | I   | Y   | i   | y                  | TAB (FOR)          | TAB (REV)          |     |     | C(N3) | F9  | C(9) |   |
| 1              | 0              | 1              | 0              | 0              | A                  | LF  | SUB | *   | :   | J   | Z   | j   | z                  | ↓                  | ↑                  |     |     | C(N.) | F10 | C(:) |   |
| 1              | 0              | 1              | 1              | 1              | B                  | VT  | ESC | +   | ;   | K   | [   | k   | {                  | HOME               | RESET              |     |     | C(N+) | F11 | C(:) |   |
| 1              | 1              | 0              | 0              | 0              | C                  | FF  | FS  | ,   | <   | L   | \   | l   |                    | CLEAR (VAR)        | CLEAR (ALL)        |     |     | C(N-) | F12 | C(,) |   |
| 1              | 1              | 0              | 1              | 1              | D                  | LC  | GS  | -   | =   | M   | ]   | m   | }                  | RTN                | NEW LINE           |     |     |       | F13 | C(-) |   |
| 1              | 1              | 1              | 0              | 0              | E                  | SO  | RS  | .   | >   | N   | ^   | n   | ~                  |                    |                    |     |     | F17   | F14 | C(.  |   |
| 1              | 1              | 1              | 1              | 1              | F                  | SI  | US  | /   | ?   | O   | _   | o   | DEL                |                    |                    |     |     | F18   | F15 | C(/) |   |

- NOTES: 1. THE 13 CODES LABELED C(NX) ARE GENERATED FROM NUMERIC PAD PLUS CONTROL KEY.
2. THE 16 CODES LABELED C(X) ARE GENERATED FROM THE STANDARD KEYBOARD USING THE CONTROL KEY.
3. THE 18 CODES LABELED F(X) ARE GENERATED FROM THE EXTENDED FUNCTION PAD OPTION.

NOTE 1      NOTE 2  
 NOTE 3  
 SPECIAL CODES

Figure 3-3 Keyboard Character Coding Chart

**HONEYWELL PROPRIETARY AND CONFIDENTIAL**

Table 3-1 Keyboard Alphanumeric Cluster

| KEYS                                   | DESCRIPTION  |
|--|--|
| Alphabetic (26 keys)                   | When depressed alone, each key generates the appropriate ASCII code <u>6/1</u> through <u>7/A</u> . With SHIFT or CAP LOCK also used, codes <u>4/1</u> through <u>5/A</u> are produced. If CTL key is also depressed (SHIFT or CAP LOCK in either position), codes <u>0/1</u> through <u>1/A</u> are produced.   |
| Combined numeric and graphic (10 keys) | When depressed alone, ASCII codes <u>3/0</u> through <u>3/9</u> are produced. With SHIFT depressed, codes <u>3/D</u> and <u>2/1</u> through <u>2/9</u> are generated corresponding to the upper legends. CAP LOCK has no effect on operation of these keys. If CTL key is also depressed (independent of SHIFT key), no code is generated.   |
| Dual graphic (11 keys)                 | ASCII codes produced by these keys are shown in Table 3-3. With the CTL key also depressed (independent of position of SHIFT and CAP LOCK keys), codes <u>0/0</u> and <u>1/B</u> through <u>1/F</u> are produced when any of the six appropriate graphic symbol keys are depressed. The other five keys in this group produce no output in conjunction with CTL key. With CAP LOCK used, the five appropriate keys produce codes corresponding to upper legend on key regardless of position of SHIFT key. The other six keys operate as previously stated in combination with SHIFT and CTL keys, regardless of position of CAP LOCK key. |
| Space bar                              | When depressed, always generates ASCII code <u>2/0</u> independent of the SHIFT, CAP LOCK, and CTL keys.   |

Table 3-2 Keyboard Standard Control  
Function Group (Sheet 1 of 2)

| KEY          | DESCRIPTION  |
|--------------|--|
| DEL (delete) | When depressed, always generates ASCII code <u>7/F</u> independent of SHIFT, CAP LOCK, and CTL keys. |
| ESC (escape) | When depressed, always generates ASCII code <u>1/B</u> independent of SHIFT, CAP LOCK, and CTL keys. |

**HONEYWELL PROPRIETARY AND CONFIDENTIAL**

Table 3-2 Keyboard Standard Control  
Function Group (Sheet 2 of 2)

|                | DESCRIPTION   |
|----------------|---|
| RETURN         | When depressed, always generates ASCII code <u>0/D</u> independent of SHIFT, CAP LOCK, and CTL keys.  |
| LF (line feed) | When depressed, always generates ASCII code <u>0/A</u> independent of SHIFT, CAP LOCK, and CTL keys.  |
| CAP LOCK       | An alternate action key which locks down when depressed and unlocks when depressed again. When down, modifies codes generated by the 26 alphabetic and 5 dual graphic keys in same manner as SHIFT key.   |
| SHIFT          | Generates no output by itself but when depressed in combination with certain other keys, modifies their generated codes to correspond to ASCII uppercase alphabetic codes or to codes corresponding to upper legends on keytops.  |
| CTL (control)  | Generates no output by itself but when depressed in combination with certain other keys modifies their generated codes to the bit paired corresponding to the ASCII control function codes in columns 0 and 1 (see Figure 3-2).   |
| RPT (repeat)   | When depressed, produces a dc voltage output which has no effect by itself. However, if held down while depressing any graphic character key or coded function key (with or without SHIFT), this key causes output code to be repeated at a rate of approximately 15 characters per second until RPT key is released. |
| BRK (break)    | When depressed, produces a dc voltage output which causes a space code to be sent to modem for 130 milliseconds (conventional teletypewriter discipline interrupt).   |
| END OF MESSAGE | When depressed, produces a dc voltage output which causes interface signal CA (Request To Send) to go to off state when terminal is being operated in half-duplex (two-way alternate) mode.   |
| Blank (key 28) | When depressed, this key produces a dc voltage output. It is reserved for possible future use.  |

**HONEYWELL PROPRIETARY AND CONFIDENTIAL**

Table 3-3 Code Chart for Dual Graphic Keys

| LOWER | UPPER | ASCII CODE GENERATED |            |              |               |
|-------|-------|----------------------|------------|--------------|---------------|
|       |       | DEPRESSED ALONE      | WITH SHIFT | WITH CONTROL | WITH CAP LOCK |
| \     | @     | <u>6/0</u>           | <u>4/0</u> | <u>0/0</u>   | <u>4/0</u>    |
| {     | [     | <u>7/B</u>           | <u>5/B</u> | <u>1/B</u>   | <u>5/B</u>    |
| :     | \     | <u>7/C</u>           | <u>5/C</u> | <u>1/C</u>   | <u>5/C</u>    |
| }     | ]     | <u>7/D</u>           | <u>5/D</u> | <u>1/D</u>   | <u>5/D</u>    |
| ~     | ^     | <u>7/E</u>           | <u>5/E</u> | <u>1/E</u>   | <u>5/E</u>    |
| -     | _     | <u>2/D</u>           | <u>5/F</u> | <u>1/F</u>   |               |
| /     | ?     | <u>2/F</u>           | <u>3/F</u> | No Output    |               |
| +     | *     | <u>2/B</u>           | <u>2/A</u> | No Output    |               |
| ,     | <     | <u>2/C</u>           | <u>3/B</u> | No Output    |               |
| .     | >     | <u>2/E</u>           | <u>3/E</u> | No Output    |               |
| ;     | :     | <u>3/B</u>           | <u>3/A</u> | No Output    |               |
| +     | *     | <u>2/B</u>           | <u>2/A</u> | No Output    |               |

NOTES

1. SHIFT key may be in either position.
2. CAP LOCK does not affect operation of these keys. SHIFT key causes same actions shown in columns 2 and 3.



Table 3-4 Keyboard Editing Function Group

| KEY              | FUNCTION NAME                            | MNEMONIC | GENERATED OUTPUT CODE SEQUENCE |
|------------------|--|----------|--------------------------------|
| ↑                | Cursor up                                | CUU      | <u>1/B, 4/1</u>                |
| ↓                | Cursor down                              | CUD      | <u>1/B, 4/2</u>                |
| →                | Cursor forward                           | CUF      | <u>1/B, 4/3</u>                |
| ←                | Cursor backward                          | CUB      | <u>1/B, 4/4</u>                |
| HOME             | Cursor home                              | CUH      | <u>1/B, 4/8</u>                |
| CLR              | Reset to initial state                   | RIS      | <u>1/B, 6/0</u>                |
| ERASE<br>EOL/EOP | Erase end of line                        | EL       | <u>1/B, 4/B</u>                |
|                  | Erase end of page (with SHIFT depressed) | ED       | <u>1/B, 4/A</u>                |
| TRANSMIT         | Transmit data                            | MC       | <u>1/B, 6/9</u>                |

### 3.1.5 Special Control Function Keys

This group of seven special function keys are designated F1 through F7. When depressed, each of these keys produces an output consisting of a two-character escape sequence as indicated in Figure 3-4. Codes designated F1 through F7 are produced when the keys alone are depressed. Codes FS1 through FS7 are produced when these keys are depressed in combination with the SHIFT key. The CAP LOCK and CTL keys have no effect.

### 3.1.6 Auxiliary Function Keypad Option

The optional 18-key auxiliary function keypad layout is shown in Figure 3-5. The two-character escape sequence codes produced by these keys are designated as AF0 through AF17 in Figure 3-4. The SHIFT, CAP LOCK, and CTL keys on the main keyboard have no effect on these auxiliary function keys.

## 3.2 KEYBOARD ASSOCIATED FUNCTIONS

### 3.2.1 Transmit Data Function

The XMIT (transmit) key initiates transmission of data from the terminal to the host when the unit is operating in one of the buffered (line or page) transmission modes.

#### 3.2.1.1 Transmit Procedure

Depressing the XMIT key generates the two-character escape sequence code MC (1/B, 6/9) within the terminal. When operating in the buffered mode (line or page), this code is not transmitted; however, because of the local copy connection, it is decoded by the

HONEYWELL PROPRIETARY AND CONFIDENTIAL

display logic and interpreted as the instruction to initiate transfer of data from the terminal to the host system.

TWO CHARACTER SEQUENCE = I/B (2nd. CHAR.), WHERE 2nd. CHAR. IS:

| Bits           |                |                |                |                | 0                | 1   | 2 | 3   | 4    | 5    | 6   | 7 |
|----------------|----------------|----------------|----------------|----------------|------------------|-----|---|-----|------|------|-----|---|
| b <sub>7</sub> | b <sub>6</sub> | b <sub>5</sub> | b <sub>4</sub> | b <sub>3</sub> | COLUMN           |     |   |     |      |      |     |   |
|                |                |                |                | b <sub>2</sub> | b <sub>1</sub> * | ROW |   |     |      |      |     |   |
|                |                |                |                |                | 0                | 1   | 2 | 3   | 4    | 5    | 6   | 7 |
| 0              | 0              | 0              | 0              | 0              |                  |     |   | F1  |      | AF0  | RIS |   |
| 0              | 0              | 0              | 1              | 1              |                  |     |   | FS1 | CUU  | AF1  |     |   |
| 0              | 0              | 1              | 0              | 2              |                  |     |   | F2  | CUD  | AF2  |     |   |
| 0              | 0              | 1              | 1              | 3              |                  |     |   |     | CUF  | AF3  |     |   |
| 0              | 1              | 0              | 0              | 4              |                  |     |   |     | CUB  | AF4  |     |   |
| 0              | 1              | 0              | 1              | 5              |                  |     |   | FS2 |      | AF5  |     |   |
| 0              | 1              | 1              | 0              | 6              |                  |     |   | F3  |      | AF6  | HVP |   |
| 0              | 1              | 1              | 1              | 7              |                  |     |   | FS3 |      | AF7  |     |   |
| 1              | 0              | 0              | 0              | 8              |                  |     |   | F4  | CUH  | AF8  |     |   |
| 1              | 0              | 0              | 1              | 9              |                  |     |   | FS4 |      | AF9  | MC  |   |
| 1              | 0              | 1              | 0              | A              |                  |     |   | F5  | ED   | AF10 |     |   |
| 1              | 0              | 1              | 1              | B              |                  |     |   | FS5 | EL   | AF11 |     |   |
| 1              | 1              | 0              | 0              | C              |                  |     |   | F6  |      | AF12 |     |   |
| 1              | 1              | 0              | 1              | D              |                  |     |   | FS6 |      | AF13 |     |   |
| 1              | 1              | 1              | 0              | E              |                  |     |   | F7  | AF16 | AF14 |     |   |
| 1              | 1              | 1              | 1              | F              |                  |     |   | FS7 | AF17 | AF15 |     |   |

\*b<sub>1</sub> IS LOW-ORDER BIT.

Figure 3-4 Keyboard-Generated Two-Character Escape Sequences

|        |        |        |
|--------|--------|--------|
| (AF0)  | (AF1)  | (AF2)  |
| (AF3)  | (AF4)  | (AF5)  |
| (AF6)  | (AF7)  | (AF8)  |
| (AF9)  | (AF10) | (AF11) |
| (AF12) | (AF13) | (AF14) |
| (AF15) | (AF16) | (AF17) |

Figure 3-5 Optional Auxiliary Function Keypad Layout

When operating in the half-duplex mode, the first action of this sequence of events is to activate the line turnaround to assure that the terminal is in the transmit state.

With the mode select switches set for buffered page mode, data is transmitted serially, character-by-character, starting at the home position and proceeding line-by-line, but not including, the cursor position.

With the mode select switches set for buffered line mode, data is transmitted in the same manner except the transmission starts at the beginning of the line in which the cursor is located rather than at the home position.

NOTE

When the terminal is operating in the character mode, the XMIT key is normally not used. However, if it is depressed, the MC code will be generated and transmitted, and if echoplexed back will trigger transmission of a line or page in the block mode format.

### 3.2.1.2 End of Message Procedure

Following transmission of the last data character, the terminal adds and transmits an ending character. This character can be any ASCII code in column 0 (bits 5, 6, and 7 equal to zero); however, the VIP7200 only uses NUL (0/0), ETX (0/3), EOT (0/4), LF (0/A), or CR (0/D), as determined by the switch settings for these character codes. Once a transmission sequence has been initiated, all received signals are blocked from the display and signals from the keyboard (if any) are ignored. The keyboard signals have no effect on the output until the transmission sequence (including the ending character) has been completed.

In the half-duplex operating mode after transmission of the ending character, the terminal reverts to the receive state by turning the CA (Request to Send) interface signal off and thus ending the sequence. At this point, the host can transmit an acknowledgment, send a reply, request retransmission by sending the MC code, or do nothing. Upon acknowledgement, the operator may start entering new data to the display in preparation for the next block mode transmission.

### 3.2.2 Roll/Page Mode

The roll mode is the normal operating mode. In this mode, after completion of data entry into line 24, all data on the screen rolls up one line with the top line being lost. This leaves line 24 clear to accept the next line of data. Roll-up is initiated whenever the cursor is in line 24 and a line feed code is received, or the automatic carriage return/line feed function is activated.

In the page mode, data on the screen is held in place (not permitted to roll up) by inhibiting response to a line feed code and the automatic carriage return/line feed function when the cursor is in line 24.

### 3.2.3 End of Message Key

In the half-duplex character mode this key provides line turnaround control to switch the terminal from a master (send) state to a slave (ready to receive) state by turning the CA (Request to Send) interface signal off. In buffered page or line modes, this key is not used since line turnaround is provided automatically by the terminal logic. In full-duplex modes this key has no function since the interface signal CA is strapped to remain on whenever the CD (Data Terminal Ready) signal is on.

## 3.3 DISPLAY FUNCTION

### 3.3.1 General Display Functions

The display receives signals: (1) directly from the host system as a message, (2) echoplexed from the host controller, or (3) from the keyboard when direct connected as in full-duplex/local display, half-duplex, or local modes.

HONEYWELL PROPRIETARY AND CONFIDENTIAL

The display responds to a subset of the 7-bit ASCII code and to a specific subset of escape sequence codes. The applicable code tables are shown in Figures 3-6 and 3-7 and are described in the following subsections.

| BITS |    |    |    |    | 0 0 0 | 0 0 1 | 0 1 0  | 0 1 1 | 1 0 0 | 1 0 1 | 1 1 0 | 1 1 1 |   |   |     |   |   |   |   |   |
|------|----|----|----|----|-------|-------|--------|-------|-------|-------|-------|-------|---|---|-----|---|---|---|---|---|
| b7   | b6 | b5 | b4 | b3 | b2    | b1*   | COLUMN | 0     | 1     | 2     | 3     | 4     | 5 | 6 | 7   |   |   |   |   |   |
| ROW  |    |    |    |    | 0     | 1     | 2      | 3     | 4     | 5     | 6     | 7     | 8 | 9 | A   | B | C | D | E | F |
| 0    | 0  | 0  | 0  | 0  | 0     | 0     | 0      | NUL   | DLE   | SP    | 0     | @     | P | ' | p   |   |   |   |   |   |
| 0    | 0  | 0  | 0  | 1  | 1     | 1     | 1      | SOH   | DC1   | !     | 1     | A     | Q | a | q   |   |   |   |   |   |
| 0    | 0  | 0  | 1  | 0  | 2     | 2     | 2      | STX   | DC2   | "     | 2     | B     | R | b | r   |   |   |   |   |   |
| 0    | 0  | 1  | 1  | 1  | 3     | 3     | 3      | ETX   | DC3   | #     | 3     | C     | S | c | s   |   |   |   |   |   |
| 0    | 1  | 0  | 0  | 0  | 4     | 4     | 4      | EOT   | DC4   | \$    | 4     | D     | T | d | t   |   |   |   |   |   |
| 0    | 1  | 0  | 1  | 1  | 5     | 5     | 5      | ENQ   | NAK   | %     | 5     | E     | U | e | u   |   |   |   |   |   |
| 0    | 1  | 1  | 0  | 0  | 6     | 6     | 6      | ACK   | SYN   | &     | 6     | F     | V | f | v   |   |   |   |   |   |
| 0    | 1  | 1  | 1  | 1  | 7     | 7     | 7      | BEL   | ETB   | '     | 7     | G     | W | g | w   |   |   |   |   |   |
| 1    | 0  | 0  | 0  | 0  | 8     | 8     | 8      | BS    | CAN   | (     | 8     | H     | X | h | x   |   |   |   |   |   |
| 1    | 0  | 0  | 1  | 1  | 9     | 9     | 9      | HT    | EM    | )     | 9     | I     | Y | i | y   |   |   |   |   |   |
| 1    | 0  | 1  | 0  | 0  | A     | A     | A      | LF    | SUB   | *     | :     | J     | Z | j | z   |   |   |   |   |   |
| 1    | 0  | 1  | 1  | 1  | B     | B     | B      | VT    | ESC   | +     | ;     | K     | [ | k | {   |   |   |   |   |   |
| 1    | 1  | 0  | 0  | 0  | C     | C     | C      | FF    | FS    | ,     | <     | L     | \ | l | ;   |   |   |   |   |   |
| 1    | 1  | 0  | 1  | 1  | D     | D     | D      | CR    | GS    | -     | =     | M     | ] | m | }   |   |   |   |   |   |
| 1    | 1  | 1  | 0  | 0  | E     | E     | E      | SO    | RS    | .     | >     | N     | ^ | n | ~   |   |   |   |   |   |
| 1    | 1  | 1  | 1  | 1  | F     | F     | F      | SI    | US    | /     | ?     | O     | _ | o | DEL |   |   |   |   |   |

\* b<sub>1</sub> IS LOW-ORDER BIT.

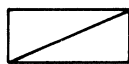

Codes not recognized by this unit. Receipt of these characters in a data stream will not cause any action; they will be ignored as if not present.

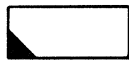

Receipt of these codes are recognized by the unit, but will be displayed as their upper case equivalents as shown in columns 4 and 5 when lower case option is not installed.

Figure 3-6 Received ASCII Codes Recognized by Receive and Display Logic

TWO CHARACTER SEQUENCE = 1/B (2nd CHAR.), WHERE 2nd CHAR. IS:

| Bits           |                |                |                |                | 0              | 1                | 2      | 3   | 4   | 5   | 6   | 7 |
|----------------|----------------|----------------|----------------|----------------|----------------|------------------|--------|-----|-----|-----|-----|---|
| b <sub>7</sub> | b <sub>6</sub> | b <sub>5</sub> | b <sub>4</sub> | b <sub>3</sub> | b <sub>2</sub> | b <sub>1</sub> * | COLUMN | ROW |     |     |     |   |
| 0              | 0              | 0              | 0              | 0              | 0              | 0                | 0      | 0   |     |     | RIS |   |
| 0              | 0              | 0              | 0              | 1              | 1              | 1                | 1      | 1   | CUU |     |     |   |
| 0              | 0              | 1              | 0              | 0              | 2              | 2                | 2      | 2   | CUD |     |     |   |
| 0              | 0              | 1              | 1              | 1              | 3              | 3                | 3      | 3   | SHI | CUF |     |   |
| 0              | 1              | 0              | 0              | 0              | 4              | 4                | 4      | 4   | SLI | CUB |     |   |
| 0              | 1              | 0              | 1              | 1              | 5              | 5                | 5      | 5   |     |     |     |   |
| 0              | 1              | 1              | 0              | 0              | 6              | 6                | 6      | 6   |     |     | HVP |   |
| 0              | 1              | 1              | 1              | 1              | 7              | 7                | 7      | 7   |     |     |     |   |
| 1              | 0              | 0              | 0              | 0              | 8              | 8                | 8      | 8   | CUH |     |     |   |
| 1              | 0              | 0              | 1              | 1              | 9              | 9                | 9      | 9   |     |     | MC  |   |
| 1              | 0              | 1              | 0              | 0              | A              | A                | A      | A   | ED  |     |     |   |
| 1              | 0              | 1              | 1              | 1              | B              | B                | B      | B   | EL  |     |     |   |
| 1              | 1              | 0              | 0              | 0              | C              | C                | C      | C   |     |     |     |   |
| 1              | 1              | 0              | 1              | 1              | D              | D                | D      | D   |     |     |     |   |
| 1              | 1              | 1              | 0              | 0              | E              | E                | E      | E   |     |     | RCA |   |
| 1              | 1              | 1              | 1              | 1              | F              | F                | F      | F   |     |     |     |   |

\* b<sub>1</sub> IS LOW-ORDER BIT.

NOTE

Blank codes are not recognized and cause no action in the display.

Figure 3-7 Two-Character Escape Sequence Codes Recognized by Display

3.3.2 Response to Single-Character ASCII Codes

The actions taken by the terminal upon receipt of the character codes shown in Figure 3-6 are described in Table 3-5.

NOTE

When the cursor is in column 81 and a DEL character is decoded, the cursor is subjected to an automatic CR/LF. No data is lost as a result of this action.

**HONEYWELL PROPRIETARY AND CONFIDENTIAL**

Table 3-5 Response to Single-Character ASCII Codes

| CODE  | RESPONSE   |
|---|--|
| NUL ( <u>0/0</u> )<br>and DEL<br>( <u>7/F</u> )   | The terminal accepts these codes as time-fill characters, thus assuring compatibility with slower teletypewriter-like electromechanical devices; however, no action is taken by the terminal.  |
| BEL ( <u>0/7</u> )  | Sounds the audible alarm.  |
| LF ( <u>1/A</u> )   | Moves cursor down one line: If in roll mode with cursor on bottom line, performs upward scroll.  |
| CR ( <u>0/D</u> )   | Moves cursor to start of line that it is on.   |
| ESC ( <u>1/B</u> )  | Identifies the start of a multicharacter instruction. No display action takes place until the full multicharacter escape sequence has been interpreted.  |
| SP ( <u>2/0</u> ) and<br>63 Graphic<br>characters<br>( <u>2/1</u> through<br><u>5/F</u> ) | Appropriate graphic character is displayed at cursor position overwriting and replacing any previously displayed information, if present; cursor is advanced one position to right.  |
| 31 Lowercase<br>Graphic<br>characters<br>( <u>6/0</u> through<br><u>7/E</u> )             | If terminal has lowercase feature, these characters will be displayed in the same manner as uppercase characters described above. If terminal does not have lowercase feature, these codes will be displayed as equivalent uppercase characters (the bit paired equivalents in <u>4/0</u> through <u>5/E</u> ).  |
| Other<br>remaining<br>codes   | Strike-throughs in Table 3-4 indicates that the terminal does not respond to receipt of these codes.   |
| Automatic<br>CR/LF  | As each graphic character code is received and displayed, cursor is advanced one position to right to indicate next active position. Upon entry of a graphic character in last position of a line (column 80), cursor advances to a phantom position (equivalent to a column 81) until next character has been received and interpreted. If next character is a graphic character, cursor moves to column 1 of next line, character is displayed, and then cursor moves to column 2. However, if character received (while cursor is in phantom position) is a control character, control function is performed directly. (EL/ED are inhibited and therefore ignored.) This is necessary to prevent double line feeds when receiving full line messages containing CR/LF signals as part of message. |

**HONEYWELL PROPRIETARY AND CONFIDENTIAL**

**3.3.3 Response to Two-Character  
Escape Sequence Codes**

Table 3-6 describes the actions taken by the terminal upon receipt of the two-character escape sequence codes shown in Figure 3-7.

Table 3-6 Response to Two-Character  
Escape Sequence Codes  
(Sheet 1 of 2)

| CODE                            | RESPONSE   |
|---------------------------------|--|
| SHI ( <u>1/B</u> , <u>3/3</u> ) | Set High Intensity: returns display of each subsequent character to higher intensity level (normal intensity).   |
| SLI ( <u>1/B</u> , <u>3/4</u> ) | Set Low Intensity: instructs terminal to display subsequent characters in lower intensity "background" level.  |
| CUU ( <u>1/B</u> , <u>4/1</u> ) | Cursor Up: moves cursor up one line. If already on top line, cursor wraps around and appears in same column of bottom line.  |
| CUD ( <u>1/B</u> , <u>4/2</u> ) | Cursor Down: moves cursor down one line. If already on bottom line, cursor wraps around and appears in same column of top line.  |
| CUF ( <u>1/B</u> , <u>4/3</u> ) | Cursor Forward: moves cursor right one character position without erasing or modifying contents of display memory. If cursor is at end of a line, this code advances cursor forward to a phantom position equivalent to a column 81. If cursor is already in a phantom position, this code moves it to column 1 of next line, or if on the last line, to home position.  |
| CUB ( <u>1/B</u> , <u>4/4</u> ) | Cursor Backspace: moves cursor left one character position without erasing or modifying contents of display memory. If cursor is at start of a line, this code moves cursor to a phantom position, equivalent to a column 0, of present line. If cursor is already in a phantom position, this code moves it to column 80 of previous line.* If cursor is in home position, this code moves it to phantom position of last line. |
| CUH ( <u>1/B</u> , <u>4/8</u> ) | Cursor Home: moves cursor to home position.  |
| ED ( <u>1/B</u> , <u>4/A</u> )  | Erase End of Display: erases all data from and including cursor position to end of page.   |

\*While in column zero, the terminal will ignore an EL/ED command and respond to an MC command by transmitting the full page when in page mode or transmit the remainder of the page when in line mode. This position is intended for wrapping the cursor only.



**HONEYWELL PROPRIETARY AND CONFIDENTIAL**

Table 3-6 Response to Two-Character  
Escape Sequence Codes  
(Sheet 2 of 2)

| CODE  | RESPONSE  |
|---|---|
|   | <p align="center">NOTE</p> <p>To ensure proper operation of the 9600-bit-per-second rate, one character (NUL or DEL) or a time delay equivalent to one character time must be provided in the data stream immediately following an ED or RIS code before sending the next graphic or control character code. This time delay is not required at speeds of 4800 bits per second or slower.</p>   |
| EL ( <u>1/B</u> , <u>4/B</u> )                          | Erase End of Line: erases all data from and including cursor position to end of line.   |
| RIS ( <u>1/B</u> , <u>6/0</u> )                         | <p>Reset Initial State: resets display by erasing entire screen, moving cursor to home position, and setting display to normal (high) intensity level.</p> <p align="center">NOTE</p> <p align="center">Refer to note following ED above.</p>   |
| RCA ( <u>1/B</u> , <u>6/E</u> )                         | Read Cursor Address: terminal transmits horizontal and vertical position (HVP) code sequence <u>1/B</u> , <u>6/6</u> , <u>Px</u> , <u>Py</u> where <u>Px</u> and <u>Py</u> are parameter values of current cursor address in accordance with coding shown in Figure 3-7.  |
| MC ( <u>1/B</u> , <u>6/9</u> )                          | Media Copy: initiates transfer (transmission) of data from terminal to host system.   |
| HVP ( <u>1/B</u> , <u>6/6</u> , <u>Px</u> , <u>Py</u> ) | <p>Horizontal and Vertical Position: moves cursor to horizontal and vertical position identified by parameters <u>Px</u> and <u>Py</u> in accordance with coding shown in Figure 3-8.</p> <p align="center">NOTE</p> <p>When the VIP7200 is being used for composition and special edit functions (where many of the special two-character ESC sequence cursor movement and control characters are being used), any equipment connected to the auxiliary interface should be switched to a nonprinting, standby or off condition.</p> |

CODE FOR HORIZONTAL POSITION P<sub>x</sub> (VALUES 1 → 81)  
 VERTICAL POSITION P<sub>y</sub> (VALUES 1 → 24)

| Bits           |                |                |                |                | 0 0 0    | 0 0 1 | 0 1 0 | 0 1 1 | 1 0 0 | 1 0 1 | 1 1 0 | 1 1 1 |
|----------------|----------------|----------------|----------------|----------------|----------|-------|-------|-------|-------|-------|-------|-------|
| b <sub>7</sub> | b <sub>6</sub> | b <sub>5</sub> | b <sub>4</sub> | b <sub>3</sub> | 0        | 1     | 2     | 3     | 4     | 5     | 6     | 7     |
|                |                |                |                | ROW ↓          | COLUMN → |       |       |       |       |       |       |       |
| 0              | 0              | 0              | 0              | 0              |          |       | HOME  | 17    | 33    | 49    | 65    | 81    |
| 0              | 0              | 0              | 1              | 1              |          |       | 2     | 18    | 34    | 50    | 66    |       |
| 0              | 0              | 1              | 0              | 2              |          |       | 3     | 19    | 35    | 51    | 67    |       |
| 0              | 0              | 1              | 1              | 3              |          |       | 4     | 20    | 36    | 52    | 68    |       |
| 0              | 1              | 0              | 0              | 4              |          |       | 5     | 21    | 37    | 53    | 69    |       |
| 0              | 1              | 0              | 1              | 5              |          |       | 6     | 22    | 38    | 54    | 70    |       |
| 0              | 1              | 1              | 0              | 6              |          |       | 7     | 23    | 39    | 55    | 71    |       |
| 0              | 1              | 1              | 1              | 7              |          |       | 8     | 24    | 40    | 56    | 72    |       |
| 1              | 0              | 0              | 0              | 8              |          |       | 9     | 25    | 41    | 57    | 73    |       |
| 1              | 0              | 0              | 1              | 9              |          |       | 10    | 26    | 42    | 58    | 74    |       |
| 1              | 0              | 1              | 0              | A              |          |       | 11    | 27    | 43    | 59    | 75    |       |
| 1              | 0              | 1              | 1              | B              |          |       | 12    | 28    | 44    | 60    | 76    |       |
| 1              | 1              | 0              | 0              | C              |          |       | 13    | 29    | 45    | 61    | 77    |       |
| 1              | 1              | 0              | 1              | D              |          |       | 14    | 30    | 46    | 62    | 78    |       |
| 1              | 1              | 1              | 0              | E              |          |       | 15    | 31    | 47    | 63    | 79    |       |
| 1              | 1              | 1              | 1              | F              |          |       | 16    | 32    | 48    | 64    | 80    |       |

\* b<sub>1</sub> IS LOW-ORDER BIT.

Figure 3-8 Horizontal and Vertical Cursor Position Codes for P<sub>x</sub> and P<sub>y</sub>

### 3.3.4 Parity Error in Character Codes

If a parity error is detected in any received graphic or control character code, this invalid character or function code is replaced by the 7-bit code 3/F in the display's memory, and the error is indicated on the screen by the graphic ?.

Parity errors in multicharacter control functions can result in several different conditions. If an error occurs in the first character (the ESC code), the code is replaced by the ? and the following characters are interpreted independently. If an error occurs in the second character, the two-character sequence is aborted and replaced by the ?. In the HVP four-character sequence, an error in

## HONEYWELL PROPRIETARY AND CONFIDENTIAL

Parity errors in multicharacter control functions can result in several different conditions. If an error occurs in the first character (the ESC code), the code is replaced by the ? and the following characters are interpreted independently. If an error occurs in the second character, the two-character sequence is aborted and replaced by the ?. In the HVP four-character sequence, an error in the third character causes an abort and display of a ? with the fourth character displayed as a graphic. An error in the fourth character causes a ? to be displayed at the new Px position as a result of valid reception and interpretation of the first three characters.

### 3.3.5 Audible Alarm

The audible alarm sounds upon receipt of the BEL code. An operator end-of-line warning is heard upon the keystroke following the display of the 71st character in a line. The end-of-line warning can be inhibited by an internal switch so that only the BEL code sounds the alarm.

### 3.3.6 Special Considerations

In the local display mode the keyboard and the communication channels are combined; both are considered received signals. If a key is depressed during receipt of a communication message, a garbled signal may result.

## 3.4 COMMUNICATION INTERFACE

The terminal provides both EIA and current loop interface as described in subsections 3.4.1 and 3.4.2. Both are asynchronous interfaces capable of operating at data rates up to 9600 baud. Internal switches allow selection of the appropriate interface.

### 3.4.1 EIA Interface

The terminal provides all of the interface and functional characteristics identified as Interface Type D in section 5 of the RS232C specification. The EIA interface can be used to connect the terminal to an asynchronous full-duplex modem, an asynchronous half-duplex modem, or directly to a local computer or communication adapter. Interconnection distance is limited to 50 cable feet. This interface is compatible with Western Electric data sets 103A, 103E, and 103G (full duplex) and 202C and 202D (half duplex). The EIA interface signals are shown in Figure 3-9. The auxiliary interface at the terminal extension port is a subset of the EIA communications interface.

### 3.4.2 Current Loop Interface

The terminal provides a full-duplex current loop interface which can be used for direct connection to a local computer or to a communication adapter for distances up to 1000 feet. The current loop interface signals are shown in Figure 3-10.

The current loop interface can operate at either 20-mA or 60-mA signal current as selected by an internal switch. The terminal does not provide power for the current loop interface; an external power source is required.

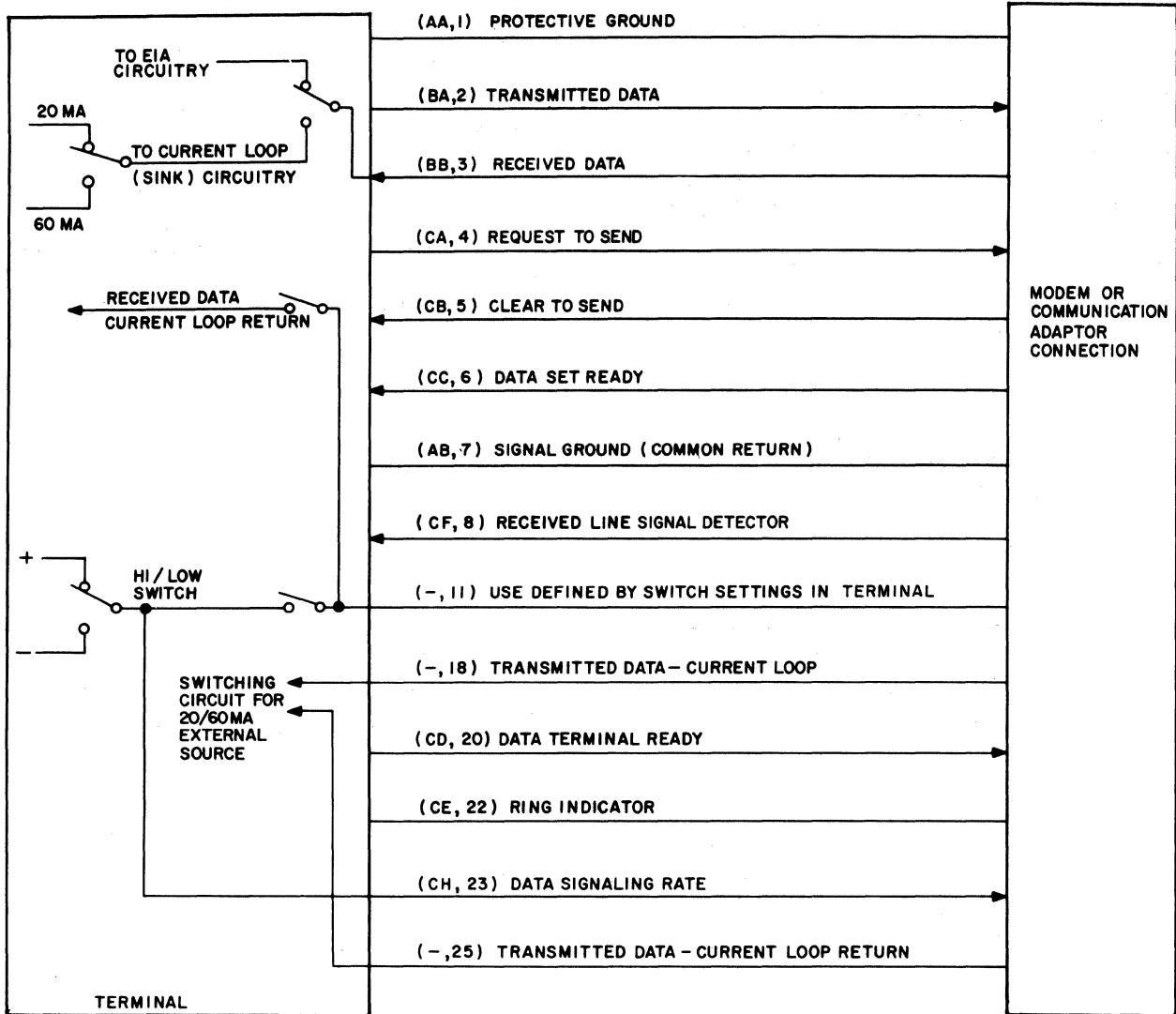

Figure 3-9 EIA Primary I/O Communication Interface

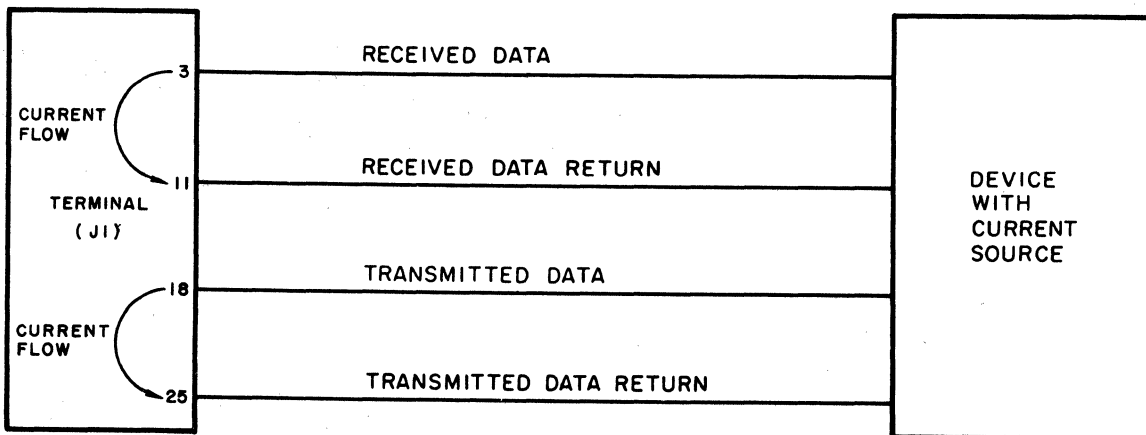

Figure 3-10 Current Loop Interface Signals

### 3.4.3 Interface Timing and Data Structure

The terminal provides configurable data rate, character structure, and character parity sense for both EIA and current loop interfaces. The following operating characteristics are selectable.

- Data Rate: 75, 110, 150, 300, 600, 1200, 1800, 2400, 4800, or 9600 baud.
- Character Structure: 10 bits (start, 7 data, parity, stop) or 11 bits (start, 7 data, parity, 2 stop).
- Parity Sense: odd, even, or mark (One) parity for 10- and 11-bit characters (mark parity for transmit, 'don't care' on receive).

### 3.4.4 Communication Procedure

The terminal does not use a formalized communication procedure; its communication functionality is similar to that of a TTY KSR. It is intended for use on point-to-point links only, and has no facilities for terminal addressing, polling, or selection.

In the half-duplex character mode, line turnaround is initiated by the first keyed data code, and the line is retained until the END OF MESSAGE key is depressed. The line is then released and turned around to receive data.

Block mode transmissions of displayed data are terminated with an ending character. This character can be any ASCII code in column 0 (bits 5, 6, and 7 equal to zero); however, the VIP7200 only uses NUL, ETX, EOT, LF, or CR. The receive portion of the communications line is blinded to all transmissions from the host while transmitting block data. Parity may be generated on transmitted data and checked on received data. Each received character is displayed, or activates the corresponding control function if the data bits correspond to one of the graphic or control characters recognized by the terminal.

## 3.5 AUXILIARY DEVICE INTERFACE

The terminal provides an auxiliary device interface (to the extension port) which is an extension of the communication interface described in subsection 3.4. The auxiliary interface is a full-duplex, limited-function EIA interface capable of operating at data rates up to 9600 baud. The auxiliary interface can be used to connect an input device, input/output device, or an output device (for example, a receive only printer) to the terminal. Interconnection distance between the terminal and the auxiliary device is limited to 50 feet.

The auxiliary device interface can be used when the communication interface is in either the EIA or current loop configuration. When the communication interface is in the current loop configuration, the terminal provides the current loop to EIA signal conversions required for the auxiliary interface.

3.5.1 Interface Signals

The auxiliary interface provides the EIA interface signals shown in Figure 3-11. The Request To Send and Data Terminal Ready signals are strapped permanently on by the terminal.

The Transmitted Data signal is produced by the terminal. It is derived and reproduced to match the data received by the terminal display logic. This data may be a combination of data received from the host system, data entered via the keyboard, data entered via the auxiliary device, and/or data transmitted from the display screen memory (depending upon the settings of the mode selection switches).

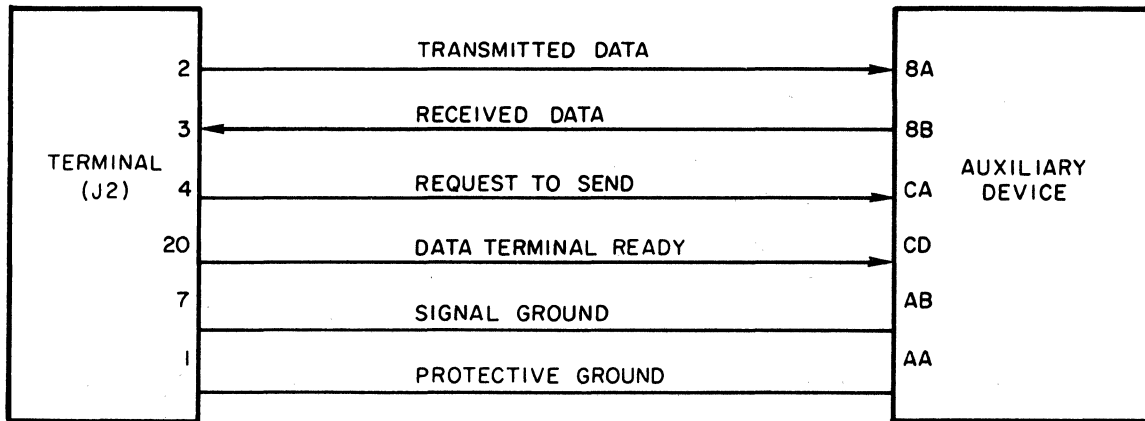

Figure 3-11 Auxiliary Interface EIA Signals

The auxiliary device extension part does not have any on/off control capabilities. Its prime use is to permit connection of an occasionally-used hard-copy printer. Some of the special edit character codes used for certain display CRT functions may cause undesirable printouts from a hard-copy printer. To prevent such occurrences, use the following guidelines.

1. When the CRT display is being used for composition and other display applications which use the edit features, the auxiliary printer should be manually switched to standby or OFF.
2. When messages are intended for hard-copy printout, and the host transmission includes special codes unique to the printer operation, the information and displayed data on the CRT should be ignored.
3. When messages are intended for hard-copy printout and CRT display, host transmission must be restricted to KSR33 ASCII subset of functions and codes.

## HONEYWELL PROPRIETARY AND CONFIDENTIAL

The Received Data signal produced by the auxiliary device is reproduced by the terminal logic at the main communication interface as an output signal (in the same manner as if this data were generated via the keyboard).

The auxiliary interface does not provide Data Set Ready or Clear To Send signals. For auxiliary devices which require these signals, the corresponding interface leads must be strapped in the auxiliary device.

### 3.5.2 Interface Timing and Data Structure

Auxiliary interface timing and data structure must be provided by the auxiliary device. The configurable data rate, character structure, and character parity that are provided for the terminal communication interface control the auxiliary interface. All transmitted and received data signals are transferred between the terminal communication interface and auxiliary interface without modification.

The auxiliary device must operate with a data rate, character structure, and parity which are consistent with one of the selectable terminal configurations.

### 3.5.3 Auxiliary Devices

Examples of devices which can be supported by the terminal auxiliary interface are:

- TTY Model 33
- TTY Model 35
- TermiNet 300
- TermiNet 1200.
- PRU1001
- PRU1003
- PRU1005

In general, the supporting software must be aware of the auxiliary device characteristics since the level of support required may be different from that required by the terminal. For example, when data is sent to a terminal with an unbuffered printer attached as an auxiliary device, a time delay is required following a carriage return/line feed. Also, supporting software must manage any inconsistencies in escape sequences, automatic carriage return/line feeds, and block mode transmissions (from the display) used by the terminal and auxiliary device.

### 3.5.4 Auxiliary Device Operation

When operating with both the terminal and an auxiliary device, the operator should observe the following precautions.

1. No interlock is provided to prevent simultaneous data entry by both the terminal and an auxiliary input device. Therefore, the operator should not allow both input devices to be active at the same time.
2. If an auxiliary input/output device provides its own on-line/local mode selection (or equivalent), both the terminal and the auxiliary device should be set in the same operating mode.

3. The terminal does not provide operator controls to inhibit output to or input from the auxiliary device. If this feature is required, appropriate controls must be provided on the auxiliary device.

### 3.6 INTERFACE FUNCTIONALITY

Communication interface functionality, auxiliary interface functionality, and the interaction among the terminal display, keyboard, and the auxiliary device are dependent on the terminal operating mode. A brief description of the interface functionality in remote/full-duplex display mode, remote/half-duplex display mode, and local mode is given in the following subsections.

#### 3.6.1 Remote/Full-Duplex Display Mode

Data received on the communication line is displayed on the terminal and sent to the auxiliary device.

Data entered via the terminal keyboard and data entered by the auxiliary device are transmitted on the communication line. When and if data is echoed back on the communication line, it is displayed on the terminal and sent to the auxiliary device.

#### 3.6.2 Remote/Half-Duplex Display Mode

Data received on the communication line is displayed on the terminal and sent to the auxiliary device.

Data entered via the terminal keyboard is displayed on the terminal, sent to the auxiliary device, and transmitted on the communication line.

Data entered by the auxiliary device is displayed on the terminal, echoed back to the auxiliary device, and transmitted on the communication line.

#### NOTE

The communications line turnaround required for signal transmission is controlled by the display. If the auxiliary device initiates a message, the END OF MESSAGE key on the keyboard must be depressed to turn the line around before data can be received from the host.

#### 3.6.3 Local Mode

Data is not transmitted on or accepted from the communication line. The communication interface Transmitted Data signal is held at logical mark (One).

Data entered via the terminal keyboard is displayed on the terminal and sent to the auxiliary device if the LOCAL COPY switch is in the LOCAL COPY position.

Data entered by the auxiliary device is displayed on the terminal and echoed back to the auxiliary device.



## HONEYWELL PROPRIETARY AND CONFIDENTIAL

### NOTE

The auxiliary communication interface Data Terminal Ready signal remains "on" even though in this mode the terminal neither transmits data nor receives data if sent by the host.

## 3.7 PERFORMANCE

### 3.7.1 Communication Data Rate

The terminal operates at data rates up to 9600 baud. The corresponding maximum character throughput rates for 9-, 10-, and 11-bit characters are 1067, 960, and 873 cps, respectively, at 9600 baud.

These throughput rates represent one-way data transfer (either input or output). Since the terminal communication interface can be operated full duplex, the maximum total throughput capability for simultaneous input/output is double the above numbers. However, since the keyboard data rate is negligible, the terminal cannot approach the maximum transmitted data rate unless an auxiliary input device is used. With an auxiliary input device, the terminal can simultaneously transmit and receive at data rates up to 9600 baud.

### 3.7.2 CRT Control Functions

The terminal provides a number of CRT control functions which are executed when the corresponding control character or escape sequences are received. The carriage return, line feed, cursor movement, bell, erase end-of-line, intensity control, and direct cursor addressing require negligible time for execution. Screen and page erase are the only CRT control functions which require a time delay.

#### 3.7.2.1 Time Delay for Erase Functions

The time delay required for the screen erase (clear screen) is one null at 9600 baud. All other baud rates do not require a time delay. Since the erase end-of-page uses the same mechanism for erasing the screen, it requires the same delay.

#### 3.7.2.2 CRT Full Screen Display Times

The maximum times required to transmit a full screen of data to the terminal are given in Table 3-7 for each of the terminal data rates. These times are based on a 24-line display, 80 characters per line, and an 11-bit character size. These figures can be used to calculate transmission times for other configurations. For example, for 60 characters per line (including CR/LF), 10-bit character size at 300 baud transmission rate, the time required to transmit 24 lines is:

$$70.4 \text{ seconds} \times \frac{60}{80} \times \frac{10}{11} = 48 \text{ seconds}$$

Table 3-7 Maximum Times for  
CRT Full Screen Display

| DATA RATE<br>(baud) | MAXIMUM TIME FOR<br>FULL SCREEN DISPLAY<br>(seconds) |
|---------------------|--|
| 75                  | 223.3  |
| 110                 | 192.0  |
| 150                 | 140.9  |
| 300                 | 70.4   |
| 600                 | 35.2   |
| 1200                | 17.6   |
| 1800                | 13.2   |
| 2400                | 8.8  |
| 4800                | 4.4  |
| 9600                | 2.2  |

# IV THEORY OF OPERATION - PRINCIPLES

This section describes the theory of operation of the terminal at the major block diagram level (see Figure 4-1). A discussion of terminal operation at an intermediate block diagram level is presented in Section VI.

Data displayed on the CRT may come from the keyboard, the host system, or an auxiliary input device (if installed) connected to the terminal extension port.

Data from the host system enters the terminal through the EIA receiver or the current loop receiver. Depending on host system and terminal configurations, the 9-, 10-, or 11-bit character data is serially received from the host system through the EIA or current loop interface receiver. The auxiliary device transfers data into this same interface block through a limited EIA receiver (full modem control is missing). The Universal Asynchronous Receiver/Transmitter (UAR/T) removes the start, parity, and stop bits from each character, may or may not check for parity, and transfers the remaining 7 bits of data into the video RAM whose address is determined by the cursor position. If parity is enabled and a parity error is detected, the control logic substitutes a question mark character into this address in place of the received character. As this address is selected by the video address scanning, the data is shifted into a video generator where the corresponding dot matrix is generated and sent on to the CRT. A clock function provides timing for horizontal and vertical synchronization, and for the selectable baud rate.

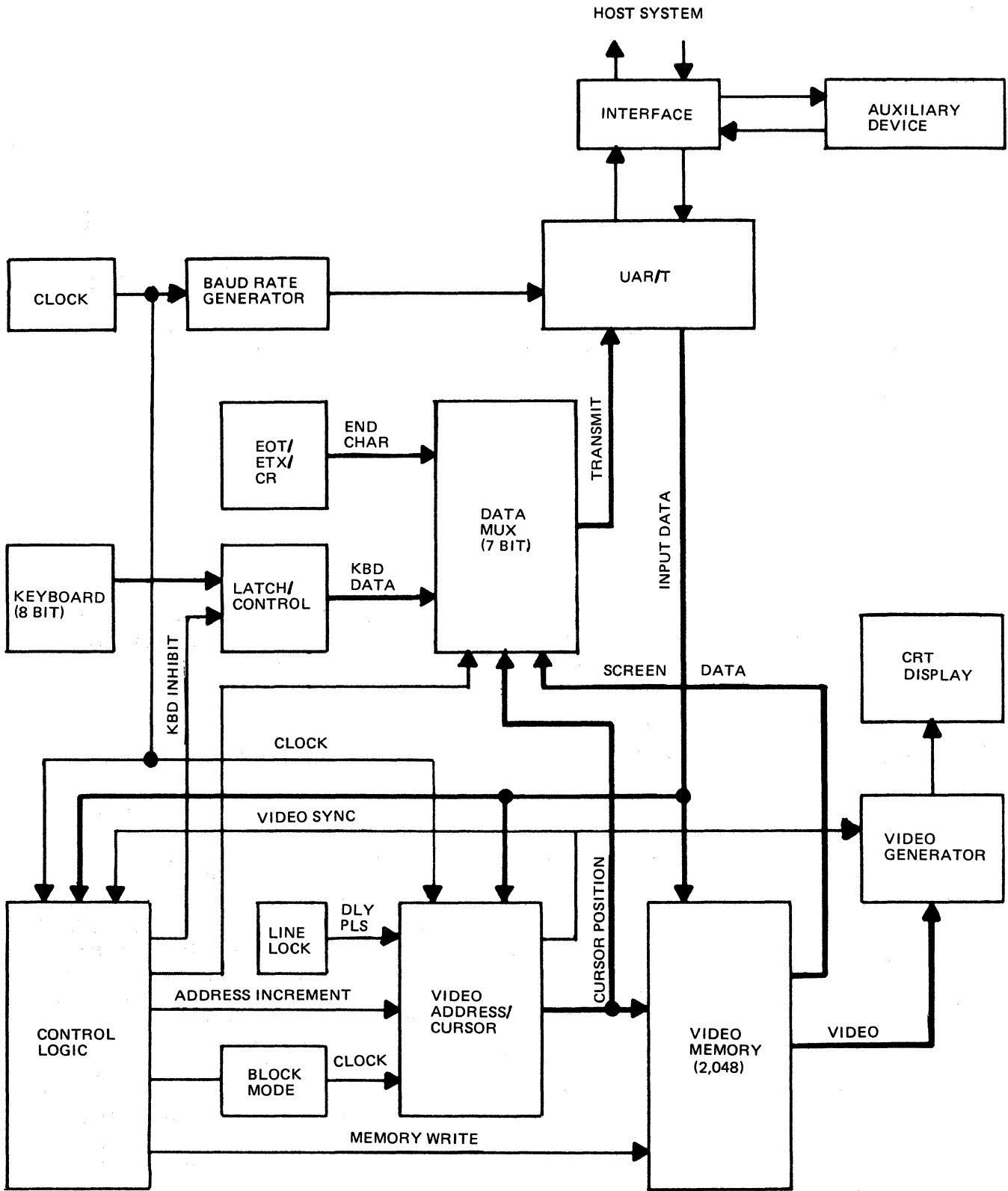

Figure 4-1 VIP7200 Major Block Diagram

## HONEYWELL PROPRIETARY AND CONFIDENTIAL

The erase function is basically a subsection of the video memory write that is speeded up to allow a faster scan through the memory locations, writing blank characters in chosen locations. The control logic determines the start and stop addresses of erase writes, and controls the rate at which locations are addressed.

In normal on-line operation, the keyboard generates an 8-bit character which is converted to one or more 7-bit ASCII characters by the latch control logic and the data multiplexer. These 7-bit characters may be one-, two-, or four-character generations. These character generations are accepted by the UAR/T which adds the proper start, parity, and stop bits. The UAR/T then sends these 9-, 10-, or 11-bit characters serially to the appropriate interface transmitter for transmission to the host system and/or auxiliary device. The data from the keyboard may be internally connected back through the UAR/T to the display, or may be echoed back by the host and processed as received data. The block mode controls the transmission of video memory through the data multiplexer, and the control logic adds the proper terminating character to the end of the transmission. The cursor address may also be transmitted and received on the data channel with proper control character sequences.

Data entered via an auxiliary device is sent to the host system through the appropriate interface transmitter and is also displayed on the CRT in the same manner as keyboard data. If the auxiliary device has output capability, all data sent to or received from the host is also presented to the device. Regardless of the type of interface used between the terminal and the host, an EIA interface is present at the auxiliary device extension port.

In all modes except echoplex, data is displayed directly on the CRT rather than being echoed back by the host system. A buffered mode which disallows all terminal transmissions except block mode transmissions is available for special editing functions.

V  
THEORY OF  
OPERATION - CYCLE FLOW

Not applicable.

# VI THEORY OF OPERATION - HARDWARE IMPLEMENTATION

This section describes the theory of operation of the terminal at the intermediate block diagram level (see Figure 6-1). If more detailed information is required, refer to the schematics, logic block diagrams, and timing diagrams contained in Section XI.

This section is organized into the following major subsections.

- Clock function
- Transmit function
- Receive function
- Cursor control function
- Block control function
- Display function
- Auxiliary devices
- CRT display.

## 6.1 CLOCK FUNCTION

The clock function provides the basic timing required by the Universal Asynchronous Receive/Transmitter (UAR/T) to transmit and receive information. It also times the horizontal and vertical counters which provide read addressing of the Random Access Memories (RAMs) and synchronization of the CRT display.

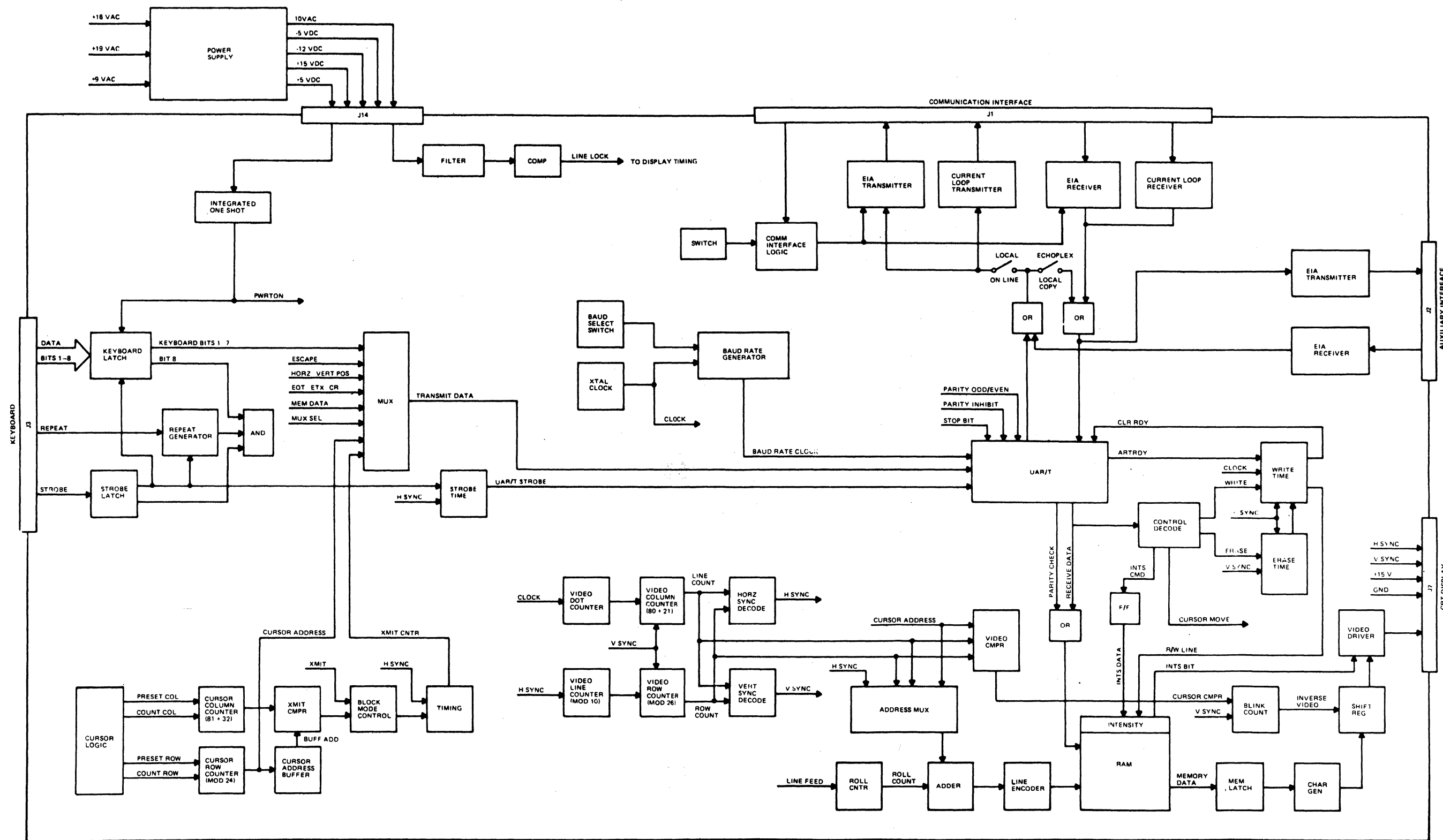

Figure 6-1 VIP7200 Intermediate Block Diagram



6.1.1 Oscillator

The oscillator is a simple circuit using ac coupling between inverters with the crystal in the feedback path. The fundamental frequency is 11.142 MHz  $\pm$ 0.005%. This frequency allows the circuitry to be switched from a 60-Hz to a 50-Hz refresh rate with an integral number of raster lines plus a delay time required for line lock: 60 Hz = 260 raster lines and 50 Hz = 310 raster lines. A filter and comparator are used on the line frequency to generate a line-lock function which locks the refresh rate to the line frequency in order to improve the quality of the display.

The baud rate generator clock is derived from this same clock by dividing by 12.

6.1.2 Baud Rate Generator

The baud rate generator contains count-down circuits which are programmed by a binary input code. The output of this generator provides the common transmit and receive clock for the Universal Asynchronous Receiver/Transmitter (UAR/T). This output is 16 times the required baud rate. The baud rate select switch settings and their associated baud rates are:

| SWITCH<br>SETTING | BAUD<br>RATE |
|-------------------|--------------|
| 2                 | 75           |
| 3                 | 110          |
| 5                 | 150          |
| 6                 | 300          |
| 7                 | 600          |
| 9                 | 1200         |
| 10                | 1800         |
| 11                | 2400         |
| 13                | 4800         |
| 15                | 9600         |

6.1.3 Power Turn On

The Power Turn On signal (PWRTON) is generated by the integrating single-shot when power to the terminal is turned on. PWRTON resets the required counters, clears the UAR/T, and causes the space encoder to write spaces in all data character locations in the RAM, thus providing a clear screen with the cursor in the home position.

6.2 TRANSMIT FUNCTION

The transmit function starts with the generation of information at the keyboard and ends with transmission of this information on the communication interface to the host system. Within this function, the information is organized into the character bit structure required by the host system.

### 6.2.1 Keyboard Input

Depressing a key on the keyboard generates one of the 256 modified ASCII 8-bit codes plus a strobe. In addition, repeat, break, end-of-message, and one blank key individually present a high or low dc output level to the keyboard interface.

When a key is depressed, a ROM encoder within the keyboard converts the keystroke into an 8-bit parallel code which is then strobed into the keyboard latch. If the repeat key is depressed (making the repeat signal true) prior to depressing a character key, the repeat control continuously generates strobes which cause data to be sent to the UAR/T; this action continues as long as the repeat key is held down. Without the repeat key, a single strobe generation cycle is initiated to the UAR/T.

The break key dc output is sent to the communication interface transmitters to activate the interrupt function for  $130 \pm 10$  milliseconds.

The end-of-message dc output is not acted upon unless the terminal is operating in a half-duplex mode on a modem with line turn-around capability. In this mode, the end-of-message key lowers Request To Send to the modem.

The blank key dc output is not acted upon unless an option (such as answer-back) is provided at some future time.

### 6.2.2 Keyboard Latch

The keyboard latch is a register which holds the keyboard data until it has been sent through the UAR/T. This function is necessary because the 8-bit keyboard code must be converted to one or two 7-bit ASCII code words before being sent through the UAR/T. The one 7-bit ASCII code word may be any valid code; the two 7-bit words consist of an escape character code and a noncontrol ASCII character code. Since bit stripping is used to determine if a two-character sequence is coming, strobes are ignored until the contents of the latch have been transferred to the UAR/T register.

With the keyboard latch are multiplexers which can load the UAR/T with keyboard data, cursor address data, or memory data. These functions are dependent upon the state of the control logic and internal timings. Also, the keyboard strobe is latched and retained to allow loading the UAR/T synchronously with the video timing as required for UAR/T transmissions from video memory.

### 6.2.3 Universal Asynchronous Receiver/ Transmitter (UAR/T)

The Universal Asynchronous Receiver/Transmitter (UAR/T) receives 7-bit parallel data from the multiplexer. Depending on the setting of the configuration switches, which in turn is dependent on the requirements of the host system, the UAR/T adds a start bit, a parity bit, and 1 or 2 stop bits to each character. The resultant 10- or 11-bit character is then shifted out serially to the communication interface transmitters at a rate established by the baud

## HONEYWELL PROPRIETARY AND CONFIDENTIAL

rate generator. There are three possible parity selections: (1) even parity, (2) odd parity, and (3) mark (always One) parity. Mark parity is obtained only with a 10-bit character having 2 stop bits (first stop bit effectively becomes the mark parity bit).

### 6.2.4 Communication Interface Transmitters

The appropriate communication interface transmitter, as determined by the terminal configuration, receives 9-, 10- or 11-bit characters serially from the UAR/T and transmits them over the communication line.

When the EIA transmitter is used, the data from the UAR/T is changed from +5 volts to -12 volts for a mark state (One bit) and from 0 volts to +12 volts for a space state (Zero bit) prior to being sent out on the communication line.

When the current loop transmitter is used, the data from the UAR/T is changed from +5 volts to a 20- or 60-milliampere current flow for a mark state (One bit) and from 0 volts to a no-current flow for a space state (Zero bit). Whether a 20- or a 60-milliampere current loop is used depends on the terminal configuration.

The terminal does not provide power or current limiting for the current loop interface; an external power source is required.

## 6.3 RECEIVE FUNCTION

The receive function starts with the receipt of incoming information from the communication interface and ends when the data is sent to the Random Access Memories (RAMs) to be processed for display by the CRT. Within this function, control characters are separated from data characters and are acted upon to provide cursor positioning (the basis for character positioning), dual intensity, and block transmission information to the display and addressing functions.

### 6.3.1 Communication Interface Receivers

Data from the communication line is received by either the EIA or the current loop receiver as determined by the terminal configuration.

When the EIA receiver is used, the data from the communication line is changed from -12 volts to +5 volts for a mark state (One bit) and from +12 volts to 0 volts for a space state (Zero bit) before being sent to the UAR/T.

When the current loop receiver is used, the data from the communication line is changed from a 20- or 60-milliampere current flow to +5 volts for a mark state (One bit) and from no-current flow to 0 volts for a space state (Zero bit) before being sent to the UAR/T.

### 6.3.2 Universal Asynchronous Receiver/ Transmitter (UAR/T)

Information coming serially from the EIA or current loop receiver to the UAR/T consists of a start bit, a 7-bit data or control character, a parity bit (if used), and 1 or 2 stop bits. The UAR/T strips off the start, parity, and stop bits, loads the 7-bit data or control character into an internal buffer register, and sends a data ready signal to the data ready control. The parity bit is latched into the parity bit buffer if the parity check switch is set. The type of parity (odd or even) is determined by the parity select switch: open selects even parity and closed selects odd parity.

### 6.3.3 Character Decoding

Every output character from the UAR/T is checked by a decoder to determine whether it is a data character or a control character. If it is not found to be a control character, it is assumed to be a data character (the one exception is the DEL character which is ignored).

#### 6.3.3.1 Control Characters

If the character received from the UAR/T by the decoder is found to be a control character, as determined by bits 6 and 7 being Zeros, the write into RAM sequence is inhibited, thus preventing a control character from being written into the RAM. The control functions are accomplished as described in the following paragraphs.

#### Bell

An audible alarm is sounded on receipt of the BEL control character. It also sounds on the first keystroke after the cursor has entered the area between columns 72 and 80.

#### Line Feed

When the line feed control character is received, the cursor counter is incremented one line count (cursor on display drops one line) except in line 24. In the roll mode with the cursor in line 24, the line feed adder register is incremented changing the row address in the RAM and thus causing the display to roll up one line with the old top line becoming the new bottom line. The space encoder then loads a row of spaces into the RAM for the new bottom line, thus clearing it of previous data. In the page mode and with the cursor in line 24, the line feed character is ignored.

#### Carriage Return

The carriage return control character resets the cursor column counter forcing the cursor back to the first position of its present line. If there is a character in the first position which is covered by the cursor, it will be displayed in inverse video.

### Escape

The escape character denotes the beginning of a multiple character command sequence. The decode of the escape character sets a mode flip-flop (reset at the end of the next decoded character) that is used with the next character to form the specific command (refer to subsection 3.3.3).

#### 6.3.3.2 Data Character

The 7-bit character in the UAR/T buffer register is always presented to the RAM except when a line of spaces is being written. If the character is a control character or control sequence (subsection 6.3.3.1), the write into RAM function is inhibited, thus preventing those character(s) from being written. If the character is not a control character or control sequence, it is assumed to be a data character and it is allowed by the RAM write control to be written into the RAM at the memory location designated by the cursor position. The write timing function allows data to be written only during horizontal sync (scan retrace) time.

For uppercase only terminals, the 7-bit data character is written into the RAM as a 6-bit character. This is done by dropping bit 6 and inverting bit 7 in its place. Thus, any lowercase character received by the terminal will be "folded over" to become an uppercase character (an exception is the DEL character which is ignored).

### 6.4 CURSOR CONTROL FUNCTION

The cursor control function consists of the cursor column counter, cursor row counter, and the logic to load, count up, count down, and reset these counters.

#### 6.4.1 Cursor Column Counter

The cursor column counter uses the display command CUL to count down (move cursor left) and CUR or a character written in the display to count up (move cursor right). The first column is a preset count of 32 with count 112 being column 81 (a phantom column off the display). The host system can change the cursor horizontal position with the HVP display command which loads this counter with a value determined by the Px portion of the command.

Additional logic presets counts 32 and 111 into the counter for cursor wraparounds (e.g., from column 81 to column 1 of the next line down, from column 1 to column 81 of the next line up, etc.). A carriage return also presets the counter to 32.

#### 6.4.2 Cursor Row Counter

The cursor row counter uses the display command CUU to count down (move cursor up) and CUD or line feed to count up (move cursor down). For the Py portion of the HVP display command, the offset of 32 is ignored and only the first five least significant bits are used. The presets are 0 and 23 corresponding to rows 1 and 24, respectively.

## HONEYWELL PROPRIETARY AND CONFIDENTIAL

Additional logic increments or decrements the row counter on cursor column wraparounds, or presets 0 or 23 for row counter wraparounds and home to end of display wraparounds.

### 6.4.3 Cursor Logic

The cursor logic controls the line feed in row 24 of page mode displays, steers the wraparound signals, removes any timing conflicts, and synchronizes events. It also decodes cursor counts for wraparound functions and for the automatic carriage return/line feed function which the cursor counter performs.

### 6.5 BLOCK CONTROL FUNCTION

The block control function contains the logic which controls the timing and data flow from the RAM to the UAR/T during block data transmissions. It consists of logic for page characterization, line characterization, and end-of-transmission character generation.

#### 6.5.1 Page Characterization

The block of data transferred during a page transmission is all data between home and the cursor. Upon initiation, the value of the cursor location is loaded into a buffer register, and the cursor counter is set to home. The UAR/T is strobed and the cursor counter incremented until the cursor counter and the buffer register are equal. At this time the end-of-transmission character generation is initiated.

#### 6.5.2. Line Characterization

The block of data transferred during a line transmission is all data between the beginning of the line and the cursor. Transmission proceeds similarly to page transmission except the cursor column counter is loaded to column 1 of the current line rather than home.

#### 6.5.3 End-of-Transmission Character Generation

The block of data is multiplexed with a switch selectable end-of-transmission character. This character can be any ASCII code in column 0 (bits 5, 6, and 7 equal to zero); however, the VIP7200 only uses EOT, ETX, CR, NUL, or LF.

### 6.6 DISPLAY FUNCTION

The display function organizes data characters into a format which can be displayed on the CRT using standard television scanning techniques. The format consists of 24 horizontal rows of 80 characters each.

Each character within the row is displayed as a pattern of dots within a 7 by 10 matrix. The character itself uses an area of 5 by 7 dots for an uppercase character and 5 by 8 dots for a lowercase character; the unused area constitutes the spaces between adjacent characters and rows. Figure 6-2 depicts the display format and shows a sample dot pattern for a character position within the format.

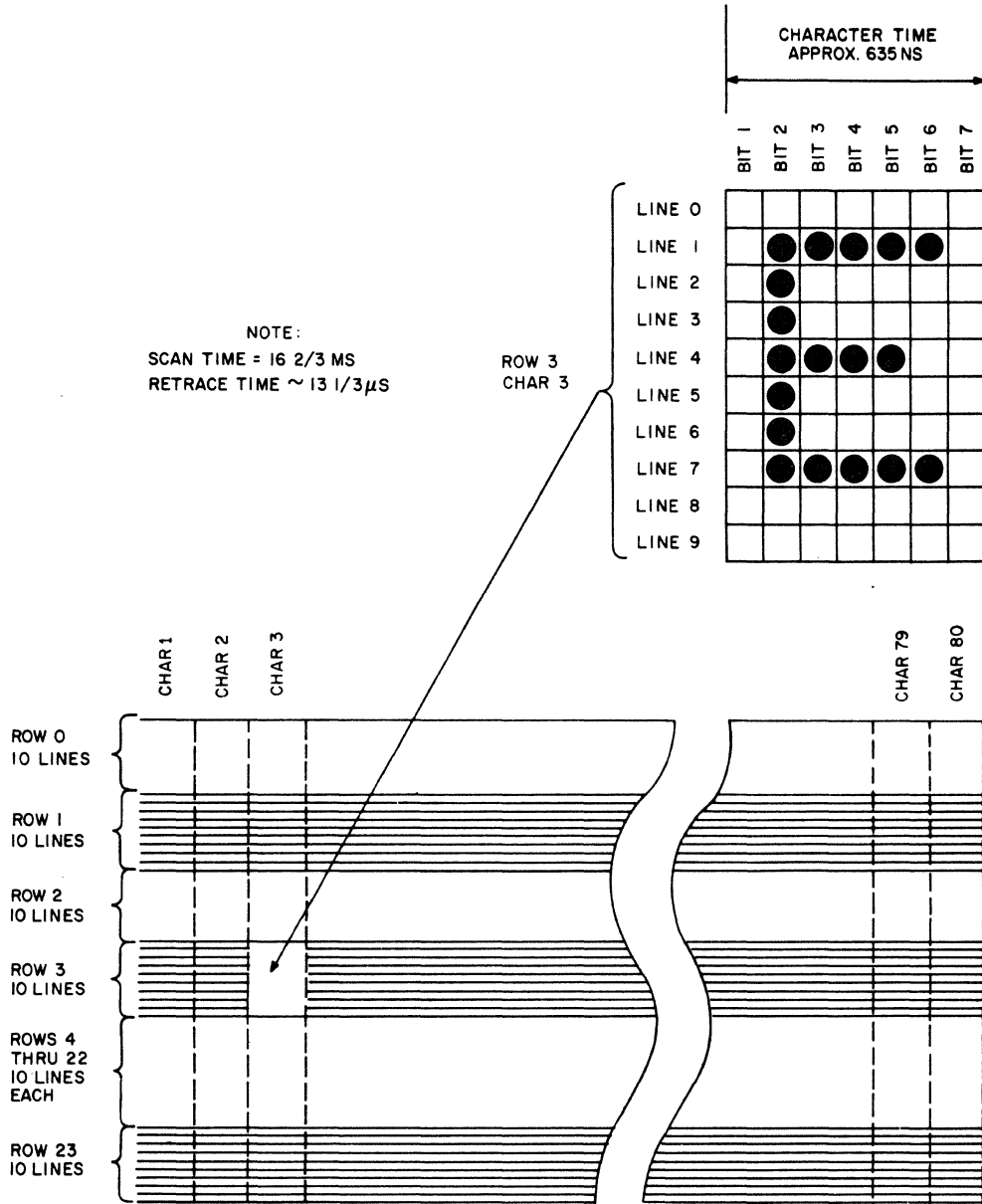

Figure 6-2 Display Format and Sample Dot Pattern

On the video display, the character matrix is formed by dot columns headed bit 1 through bit 7, and 10 horizontal raster lines (video scan lines) of the display row. As the electron beam scans from left to right, the character dot patterns are created by turning on the beam for the bits where the dots are to be formed.

## HONEYWELL PROPRIETARY AND CONFIDENTIAL

Thus, the display function logic must convert the data character ASCII codes to dot pattern bits, and then send them to the CRT display along with the necessary timing information to turn the beam on at the appropriate positions as it scans each raster line.

### 6.6.1 Random Access Memory (RAM)

The RAM stores the data character codes (6 bits for uppercase only terminals, 7 bits for upper and lowercase terminals) for the entire display (12 rows per RAM). When power is first turned on, a space code is written into every memory location, thus providing an initially clear screen.

When characters are written into the RAM, the memory is addressed by the cursor counter. After a character has been written, the cursor counter is incremented so that the next character will be written in the next adjacent position to the right. In the case of the column 80 character position, the cursor column counter advances to count 112, waits for a display character, and then resets to 32 (column 0), advancing the cursor row counter before writing the character into the RAM. Characters can only be written into the RAM during a horizontal sync (horizontal retrace) time since read addressing is taking place at all other times.

When characters are read from the RAM to be displayed on the CRT, the memory is addressed by the video column and row counter. These counters sequentially address every location in memory which represents a physical location on the display. A character is read out and displayed at each character time (approximately every 635 nanoseconds).

### 6.6.2 RAM Addressing

The RAM is addressed by 10 address lines. The 24 display rows require five address lines, and the 80 columns require seven. Since only 10 lines are available, the total row and column addresses must be reduced from 12 to 10 address inputs. Additionally, the memory address is changed each time a line feed command increments the display roll counter, rolling the display data up one line. These addressing requirements are met by adding the display roll counter and the display/cursor row multiplexer before feeding these signals to the address line reduction logic.

The encoder is used in conjunction with the address adder so that as the binary row addresses are changed by a line feed (roll), binary row 23 + 1 becomes binary row 0 (not 24), row 23 + 2 becomes row 1, etc.

The display/cursor multiplexer changes the source of the address from cursor counters (memory write) during horizontal sync to video counters (memory read) during all other times. The exceptions are the erase functions which erase (write space codes) into the memory during video counter times. These erase functions are: (1) line feed roll which erases the new line 24, (2) erase in line (EL) which erases from the cursor to the end of the line, and (3) erase in display (ED) which erases from the cursor to the end of the page.



### 6.6.3 Dot Counter

The dot counter provides the timing required for each character display time. The fundamental clock frequency of 11.142 MHz is divided by seven to provide the five dot times for display plus the two dot times which separate adjacent characters (see Figure 6-2) to the video data shift register. The output of this counter clocks the column counter at the count of seven.

### 6.6.4 Column Counter

The column counter defines each of 80 column positions along the scan line. In addition, it counts another 21 columns of time for the horizontal sync (retrace). Characters and character dot patterns are loaded by a decode from this counter. It also provides a signal for video blanking during horizontal retrace time and a column count to the cursor comparator to determine where the cursor is displayed. The output of this counter clocks the video line counter at the count of 111.

### 6.6.5 Video Line Counter

The video line counter defines each of the 10 raster lines within a character row. As characters are read out of the RAM at each character time, a dot pattern is generated (see Figure 6-2). This counter determines which line of the dot pattern is to be loaded from the character generator into the video data shift register. It also provides a blanking signal during the scanning of the two lines used for vertical spacing between characters. The output of this counter clocks the video row counter at the count of 10.

### 6.6.6 Video Row Counter

The video row counter defines each of the 24 rows of the display. In addition, it counts another two rows of time for the vertical sync (retrace). The vertical row count changes from 26 to 31 for 60 Hz and 50 Hz, respectively. The additional four row counts for a 50-Hz terminal are also blanked with the horizontal blanking (retrace blanking).

### 6.6.7 Cursor Compare

The cursor counter is continuously compared with the RAM address counters. At the time of compare, the video data shift register output is inverted to generate the blinking reverse video which locates the cursor position on the screen. The blink is timed for counting down retrace signals to generate the blink timing.

### 6.6.8 Video Generation

The character codes (6 bits for uppercase only terminals, 7 bits for upper and lowercase terminals) read out of the RAM are presented through the output data register to the video character generator. The output of the character generator is a 5-bit representation for each of the seven lines of the 5 by 7 dot pattern matrix (eight

lines for 5 by 8 lowercase matrix). The video line counter determines which of the seven (or eight) possible outputs is required for the video raster line being scanned. This output is then loaded into the video data shift register where the bits for the spaces between characters (bits 6 and 7) are added. The 7-bit output is then shifted out serially to the CRT display as clocked by the dot counter.

The blanking control prevents the CRT beam from being turned on during horizontal and vertical retrace and during scans of row lines 0, 8, and 9 (0 and 9 for lowercase) which form the vertical spacing between rows.

#### 6.6.9 Dual Intensity

The dual intensity function is controlled by a memory bit that is addressed in the same manner as the RAM except that the data written into memory is controlled by two control sequences: Set High Intensity (SHI) and Set Low Intensity (SLI). These commands reset and set, respectively, a flip-flop output that is written into the memory during all memory write sequences. The memory is read during all character times, and the output controls the intensity level of the video drive circuit. SHI is the normal display mode, and the screen erase function (RIS) writes the memory with the high intensity level. The low intensity level is used to give a background effect for a forms mode of display.

### 6.7 AUXILIARY DEVICE INTERFACE

The auxiliary device interface allows an input, output, or input/output device to be connected to the terminal. It consists of an EIA transmitter and an EIA receiver. The transmitter receives its input from the output of the communication interface receivers. The receiver sends its output to the input of the communication interface transmitter.

### 6.8 CRT DISPLAY

The CRT display receives its video, its horizontal and vertical synchronization signals from the terminal display function, and its +15 Vdc power from the terminal power supply function. The CRT display is shown in block diagram form in Figure 6-3, and schematically in Figure 6-4. Its theory of operation is discussed in the following subsections.

#### 6.8.1 Video Amplifier

The video amplifier consists of Q101 and its associated circuitry.

The incoming video signal is applied to the display through the contrast control through R109 to the base of transistor Q101.

Transistor Q101 and its components comprise the video output driver with a gain of about 17. Q104, operating as a class B amplifier, remains cut off until a dc-coupled, positive-going

signal arrives at its base and turns on the transistor. R111 adds series feedback which makes the terminal-to-terminal voltage gain relatively independent of transistor variations as well as stabilizes the device against voltage and current changes caused by ambient temperature variations.

The negative-going signal at the collector of Q101 is dc-coupled to the cathode of the CRT. The class B biasing of the video driver allows a larger video output signal to modulate the CRT's cathode and results in a maximum available contrast ratio.

The overall brightness at the screen of the CRT is determined by the negative potential at the grid and is varied by the brightness control.

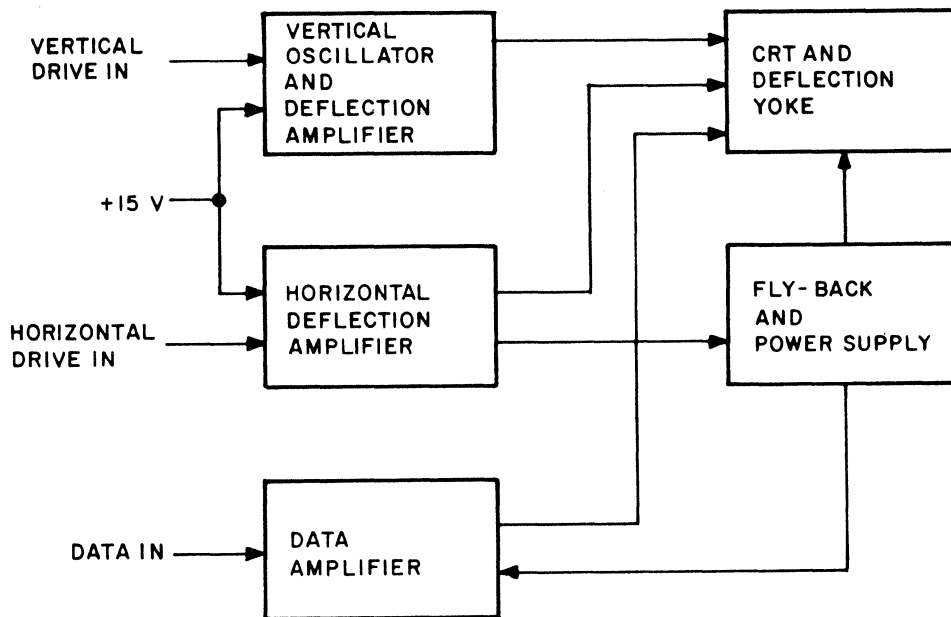

Figure 6-3 CRT Display Block Diagram

6.8.2 Vertical Deflection

Transistor Q102 is a programmable unijunction transistor, and together with its external circuitry, forms a relaxation oscillator operating at the vertical rate. Resistor R115, variable resistor R116, and capacitors C105 and C106 form an RC network providing proper timing.

When power is applied, C105 and C106 charge exponentially through R115 and R116 until the voltage at the junction of R116 and C105 equals the anode A firing voltage. At this time, one of the unijunction's diodes that is connected between the anode and anode

## HONEYWELL PROPRIETARY AND CONFIDENTIAL

gate G becomes forward-biased, allowing the capacitors to discharge through another diode junction between the anode gate and the cathode K and then on through R120.

R117 and R118 control the voltage at which the diode (anode-to-anode gate) becomes forward-biased. This feature programs the firing of Q102 and prevents the unijunction from controlling this parameter. Therefore, the charging of firing points from one device to another, together with the temperature dependency of this parameter, is no longer a problem as it can be with conventional unijunction transistors.

The vertical oscillator is synchronized externally to the vertical interval from the vertical drive pulse at R113. At the time of the vertical interval, an external negative pulse is applied through R113, C104, and CR101 to the gate of Q102, causing the firing level of the unijunction to decrease.

The sawtooth voltage at the anode of Q102 is directly coupled to the base of Q103. Q103 is a driver amplifier and has two transistors wired as a Darlington pair; their input and output leads exit as a three-terminal device. This device exhibits a high in-out impedance to Q102, and thereby maintains excellent impedance isolation between Q102 and Q104.

The output waveform from the unijunction oscillator is not suitable, as yet, to produce a satisfactory vertical sweep. Such a waveform would produce severe stretching at the top of the picture and compression at the bottom. C105 and C106 modify the output waveform to produce satisfactory linearity. The sawtooth waveform output at Q103 is coupled through R122, the vertical linearity control R121, and on to C106 where the waveform is shaped into a parabola. This parabolic waveform is then added to the oscillator's waveform, changing its slope. Slope change rate is determined by the position of the variable resistor R121.

Q103 supplies base current through R123 and R124 to the vertical output transistor, Q104. Height control R124 varies the amplitude of the sawtooth voltage present at the base of Q104, and therefore, varies the size of the vertical raster on the CRT.

The vertical output stage, Q104, uses a power type transistor which operates as a Class A amplifier. No output transformer is required since the output impedance of the transistor permits a proper impedance match with the yoke connected directly to the collector. C107 is a dc-blocking capacitor which allows only ac voltages to produce yoke current. L1 is a relatively high impedance compared to the yoke inductance. During retrace time, a large positive pulse is developed by L1 which reverses the current through the yoke and moves the beam from the bottom of the screen to the top. Resistor R126 prevents oscillations by providing damping across the vertical deflection coils.

### 6.8.3 Horizontal Deflection

To obtain a signal appropriate for driving Q106, the horizontal output transistor, a driver stage consisting of Q105 and T101 is used. The circuitry associated with Q105 and Q106 has been designed to optimize the efficiency and reliability of the horizontal deflection circuits.

A positive-going pulse is coupled through R127 to the base of Q105. The amplitude and duty cycle of this waveform must be as indicated in the electrical specifications (refer to Section XI) for proper circuit operation.

The driver stage is either cut off or driven into saturation by the base signal. The output signal appears as a rectangular waveform and is transformer-coupled to the base of the horizontal output stage. The polarity of the voltage at the secondary of the driver transformer is chosen such that Q106 is cut off when Q105 conducts and vice versa.

During conduction of the driver transistor, energy is stored in the coupling transformer. The voltage at the secondary is then positive and keeps Q106 cut off. As soon as the primary current of T101 is interrupted due to the base signal driving Q105 into cut off, the secondary voltage changes polarity. Q106 starts conducting, and its base current flows. This gradually decreases at a rate determined by the transformer inductance and circuit resistance.

The horizontal output stage has four main functions: to supply the yoke with the correct horizontal scanning currents; to develop a +400-Vdc supply voltage for use with the CRT; to develop a +34-Vdc supply voltage for the video output stage; and to develop a -160 Vdc for the CRT bias.

Q106 acts as a switch which is turned on or off by the rectangular waveform on the base. When Q106 is turned on, the supply voltage plus the charge on C113 causes yoke current to increase in a linear manner and moves the beam from near the center of the screen to the right side. At this time, the transistor is turned off by a positive voltage on its base which causes the output circuit to oscillate. A high reactive voltage in the form of a half-cycle negative voltage pulse is developed by the yoke's inductance and the primary of T2. The peak magnetic energy which was stored in the yoke during scan time is then transferred to C109 and the yoke's distributed capacity. During this cycle, the beam is returned to the center of the screen.

The distributed capacity now discharges into the yoke and induces a current in a direction opposite to the current of the previous part of the cycle. The magnetic field thus created around the yoke moves the scanning beam to the left of the screen.

After slightly more than half a cycle, the voltage across C109 biases the damper diode CR103 into conduction and prevents the fly-back pulse from oscillating. The magnetic energy that was stored in the yoke from the discharge of the distributed capacity is released

## HONEYWELL PROPRIETARY AND CONFIDENTIAL

to provide sweep for the first half of scan and to charge C113 through the rectifying action of the damper diode. The beam is then at the center of the screen. The cycle will repeat as soon as the base voltage of Q106 becomes negative.

C113, in series with the yoke, also serves to block dc currents through the yoke and to provide "S" shaping of the current waveform. "S" shaping compensates for stretching at the left and right sides of the picture tube because the curvature of the CRT face and the deflected beam do not describe the same arc.

L101 is an adjustable width control placed in series with the horizontal deflection coils. The variable inductive reactance allows a greater or lesser amount of the deflection current to flow through the horizontal yoke and, therefore, varies the width of the horizontal scan.

The negative flyback pulse developed during horizontal retrace time is rectified by CR104 and filtered by C110. This produces approximately -160 Vdc which is coupled through the brightness control to the cathode of the CRT (V1).

This same pulse is transformer-coupled to the secondary transformer T2 where it is rectified by CR2, CR106, and CR105 to produce rectified voltages of approximately 12kV, +400 Vdc, and +34 Vdc, respectively. The 12kV is the anode voltage for the CRT, and the +400 Vdc serves as the source voltage for grids No. 2 and 4 (focus grid) of the CRT. The +34-Vdc potential is the supply voltage for the video output amplifier, Q101.

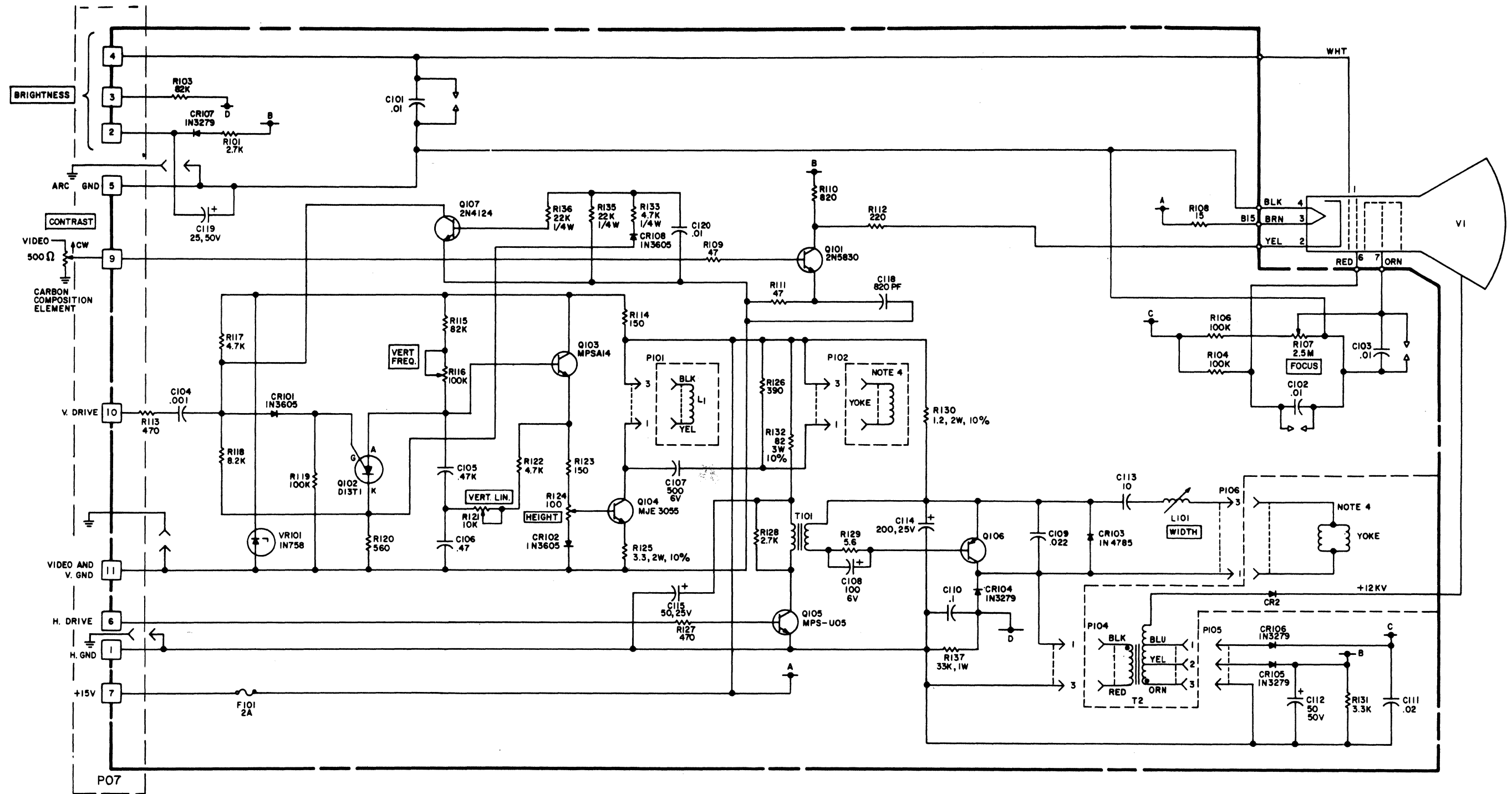

- NOTES:
1. UNLESS OTHERWISE SPECIFIED: ALL RESISTORS ARE 1/2W ± 5%, ALL CAPACITORS ARE IN μF.
  2. ← DENOTES MOLEX PIN CONNECTOR.
  3. □ DENOTES PRINTED CIRCUIT CARD EDGE CONNECTOR.
  4. YOKE LEAD IDENTIFICATION: P106 - BLUE AND RED LEADS, P102 - BROWN AND YELLOW LEADS.

| TEST POINT | VOLTAGE |
|------------|---------|
| A          | +15     |
| B          | +34     |
| C          | +400    |
| D          | -180    |



Figure 6-4 CRT Display Schematic Diagram

# VII FAULT DIAGNOSIS

This section contains both off-line and on-line diagnostic procedures which can isolate a single VIP7200 failure to an Optimum Replaceable Unit (ORU). Specifications for the on-line program used with the on-line procedure are also included. The decision to use either the off-line or the on-line procedure will depend on the availability of a host computer system (and program) and/or the thoroughness with which the VIP7200 must be exercised to detect and isolate a faulty ORU. Both procedures require approximately the same amount of time (at a line speed of 300 baud, however, the off-line procedure exercises approximately 90% of the unit, whereas the on-line exercises nearly 100%).

The ORUs for the VIP7200 are (in decreasing order of overall failure rate):

- CRT display
- Keyboard/function pad
- Logic PWA
- Power supply PWA
- Power transformer
- EMI filter
- Front panel indicators, switches, and cable.

Replacement procedures for these ORUs are provided in Section VIII of this manual.

## 7.1 OFF-LINE DIAGNOSTIC PROCEDURES

These procedures are designed to test the terminal with increasingly rigorous tests. The first level of testing is simple,



operator-generated, keyboard-to-display tests. These procedures require no external device although references are made to an auxiliary device which may be used if it is available. Similarly, some of these procedures make use of a remote receiver and transmitter, if available, to aid in better fault isolation. The most rigorous level of testing is designed for use by a Field Engineering Representative (FER).

It is assumed that the operator has made a reasonable effort to verify that the problem is not a mistake in operating procedure. The quickest way to verify the terminal is to swap it with another terminal if one is available at the site.

Before these procedures are used, however, perform the following checks.

- Is power available to the terminal? Check the power source, the power plug, the POWER ON/OFF switch, and the fuse on the back of the terminal.
- Check the data set and keyboard connectors to be sure they are properly installed.
- Check the ON LINE/LOCAL switch. It should be set to ON LINE for normal operation.
- Check the BRIGHTNESS control to be sure that it is turned up enough to get a display.
- Check the BAUD RATE selection switch for the proper setting.
- Check the STOP BIT switch for the proper setting.
- FERs should refer to Section IX Installation, and check to be sure that the terminal is properly configured for its current application.

The fault diagnosis procedures contained in the following subsections function as a flow chart; i.e., the user is often directed to advance to another procedure and then return to complete the original procedure. The user should follow the directions in each applicable procedure starting with Blank Screen. If a procedure resolves a failure to more than one possible ORU, a number following each identified ORU indicates the relative probability of failure. For example, CRT display chassis (8) or PWA (1) means that the CRT display chassis is eight times more likely to be faulty than the PWA. In these cases, the user is directed to subsection 7.1.10 which contains FER procedures to further isolate a fault to one of the multiple ORUs. Usually an oscilloscope will be required to use those procedures.

#### 7.1.1 Blank Screen

Perform the following procedure to test a blank screen.

1. Turn terminal off (if already on) and then on again. Select LOCAL mode and LOCAL COPY on terminal, and set auxiliary device (if attached) to receive from terminal. Allow a few minutes for CRT display to warm up if terminal had previously been off.

2. Terminal should have a blank screen with a bright blinking cursor (nonblinking cursor available) on top line at left-hand side of screen (home position). If true, go to video line control procedure in subsection 7.1.2.
3. If terminal's screen contains random data or if cursor is at a position other than home position, replace logic PWA.
4. If terminal does not have a blank screen with a bright cursor in home position, turn BRIGHTNESS control clockwise as far as it will go. A raster (horizontal scan lines in image area of screen) should appear. If raster appears, turn BRIGHTNESS control counterclockwise until raster just disappears, and then go to video line control procedure in subsection 7.1.2.
5. If raster appears on screen but is very dim, distorted, or not centered, faulty ORU may be CRT display chassis (80) or supply PWA (1). If further resolution is required, go to subsection 7.1.11.
6. If raster still does not appear on screen, type CTL-G. Audible alarm should sound.
7. If audible alarm sounds, power is available to terminal. Faulty ORU is probably CRT display chassis.
8. If audible alarm does not sound, verify that terminal has ac power available to it (i.e., that terminal is plugged in and receptacle has power).
9. Check fuse on back of terminal and replace it if necessary. If fuse blows again, faulty ORU is probably EMI filter.
10. If ac power is available and fuse is good, turn terminal on and off a few times and note feel of POWER ON/OFF switch. If switch does not feel right, problem may be a defective switch.
11. If switch feels normal, power supply PWA is probably faulty. If further resolution is required, go to subsection 7.1.10.

#### 7.1.2 Video Line Control

Perform the following procedure to test the video line control.

1. Turn terminal off.
2. If auxiliary device is available and being used, ensure that 7200's external port is cabled to that device's data set interface connector. In addition, check that baud rates, parity scheme, and stop bit selection of the two units are compatible.
3. Turn terminal on. If unit does not have a blank screen with cursor at home position (top line, left margin), return to Blank Screen Test, subsection 7.1.1. Deactivate CAPS LOCK key, if depressed. If an auxiliary printer is



HONEYWELL PROPRIETARY AND CONFIDENTIAL

If no characters are displayed, or if characters that are displayed are not correct, go to auxiliary device procedure in subsection 7.1.9 if a device is available. If that procedure is executed without an error, faulty ORU is probably PWA. However, if that procedure detects an error, faulty ORU is probably keyboard. If an auxiliary device is not available, faulty ORU is either PWA or keyboard. The quickest way to isolate fault is to interchange keyboard with another one. If further resolution is required, go to subsection 7.1.10.

- 7. This step is designed to verify character storage of terminal. Depress CLR and then depress repeat (RPT) and the U key, holding repeat key down until bottom row is filled with Us. When 24th line is almost full, release repeat key and type Us until this last row is full; i.e., the cursor is advanced to the phantom (column 81) position and disappears. If repeat function does not work, faulty ORU may be keyboard (4) or PWA (1). If an auxiliary unit is monitoring this test, it may need manual line feeds and carriage returns to prevent overstriking in its rightmost position. The operator should observe the following pattern on the screen as long as the keyboard is not touched.

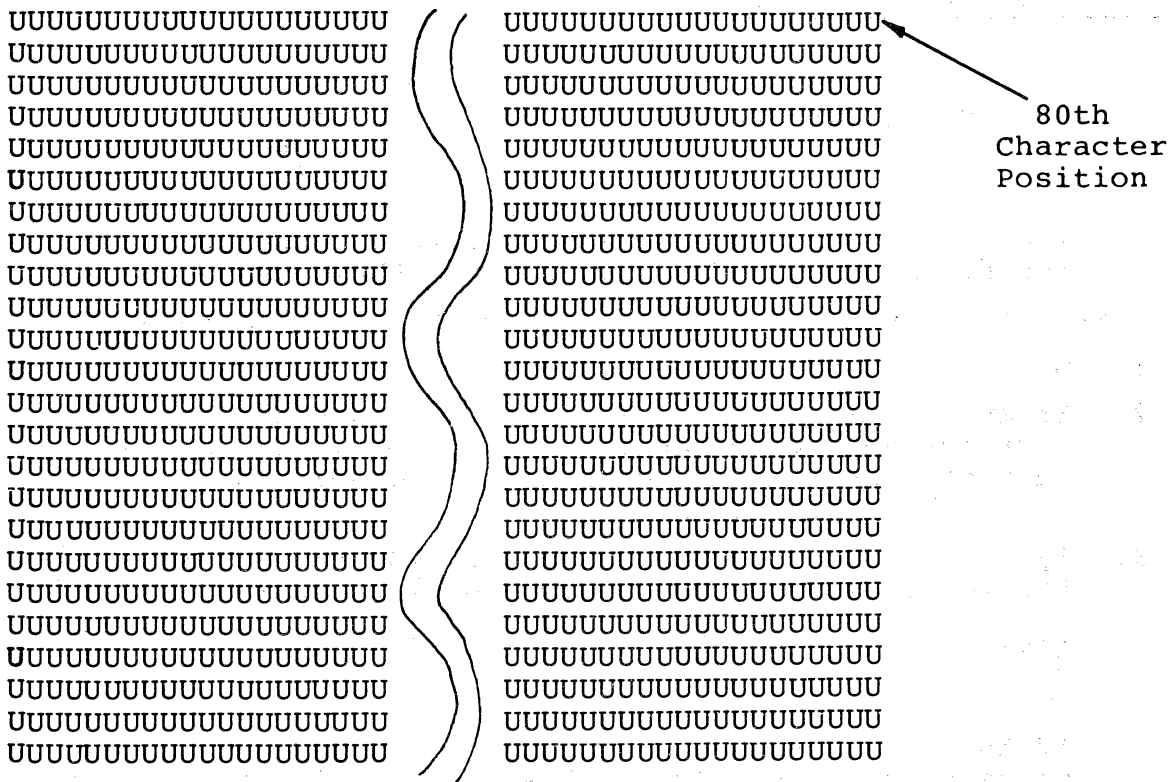

- a. Look carefully at lines on display. If they are non-linear or out of focus, faulty ORU is CRT display chassis.
- b. If lines look dim (even after brightness control has been adjusted), faulty ORU is either logic PWA or CRT display chassis.

**HONEYWELL PROPRIETARY AND CONFIDENTIAL**

- c. If lines are jittering or waving (especially at side margins), faulty ORU is either power supply (10 Vac) PWA or logic PWA.
- d. If line pattern is correct but character indicated is not, execute auxiliary device procedure (see subsection 7.1.8). If an auxiliary device is not available, perform mini keyboard test (see subsection 7.1.3).
- e. If total pattern is not correct but at least one line is correct, faulty ORU is PWA.
- f. If total pattern is not correct and none of lines are correct, faulty ORU is PWA (2) or CRT display chassis (1).

If further resolution is required, go to subsection 7.1.10.

8. Repeat step 7 using \*s in place of Us. Display on screen should be exactly same except it should be filled with asterisks.

If auxiliary device procedure has been executed without error, faulty ORU is PWA. If it has been executed with an error, faulty ORU is keyboard (4) or PWA (1).

7.1.3 Mini Keyboard Test

NOTE

If testing has progressed successfully at this point, the power supply and transformer can be considered as fault-free. If the path of diagnosis leads to subsection 7.1.10.3, replace the logic PWA. For the remainder of these off-line tests, interpret PWA to mean logic PWA.

This procedure checks out the basic keyboard controls.

1. Depress CLR key.
2. If an auxiliary device is attached, manually return carriage and space paper up. Mark beginning of this test on paper; it will be important to be able to identify where this test began.
3. Type 248. Depress SHIFT key and type A. Depress LF and RETURN keys. Observe on top two lines of screen:

248A

□

If this step fails, execute auxiliary device procedure in subsection 7.1.9. If auxiliary device is not available, faulty ORU is keyboard (4) or PWA (1).

4. If auxiliary device procedure has been executed properly, faulty ORU is PWA.

## HONEYWELL PROPRIETARY AND CONFIDENTIAL

5. If all characters that were typed are displayed but some are displayed as multiple characters (a double 8 may appear on screen), and if auxiliary device procedure has detected same problem, faulty ORU is keyboard. Quickest way to verify keyboard operation is to interchange it with another one (if available).
6. If auxiliary device procedure has not been executed properly, faulty ORU is keyboard (100) or PWA (1).

If further resolution is required, go to subsection 7.1.10.

### 7.1.4 Keyboard Test (Uppercase)

This procedure is for uppercase only terminals. If the terminal has an upper and lowercase display, skip this procedure and go to subsection 7.1.5.

1. Depress CLR key. Deactivate CAPS LOCK key, if depressed.
2. If an auxiliary device is attached, manually return carriage and space paper up. Mark beginning of this test on paper; it will be important to be able to identify where this test began.
3. Terminal should have a blank screen with cursor in home position (top row, left margin).

#### NOTE

During the following steps, the operator should be sure that only one character is being displayed for each keystroke. A common keyboard failure mode is multiple characters displayed for a single keystroke. This failure is generally true for only one key at a time. If many characters are failing, this note should be ignored. However, if multiple characters are being displayed for each keystroke for a small number of keys (one or two), the keyboard is the faulty ORU.

4. Type from second keyboard row 1234557890/~ and observe that one character appears on top line as each is typed. Top line should appear as follows:

```
1234567890/^ □
```

5. Type qwertyuiop}+ and observe on screen:

```
1234567890/^QWERTYUIOP}+ □
```

6. Type asdfghjkl;{' and observe:

```
1234567890/^QWERTYUIOP}+ASDFGHJKL;{\ □
```

7. Type `zxcvbnm,.- and observe:

```
1234567890/^QWERTYUIOP}+ASDFGHJKL;{\@ZXCVCBVM,.- □
```

HONEYWELL PROPRIETARY AND CONFIDENTIAL

8. Depress RETURN key and observe:

1 234567890/^QWERTYUIOP]+ASDFGHJKL;]\@ZXCVBNM,.-

Cursor should have moved to left margin of screen covering the 1 and displaying it in inverse video. Freeze blinking cursor by depressing and holding break key (BRK) immediately after cursor blinks on. If inverse video is not proper, replace PWA. If depressing BRK fails to freeze cursor on, freeze cursor off by depressing BRK just as cursor blinks off. If cursor can be frozen either on or off, but not both, replace PWA. If cursor can not be frozen in either state, faulty ORU is either keyboard (5) or PWA (1).

NOTE

Nonblinking cursor available by setting switch 4 at PWA location M13 to inhibit blink position.

9. Depress LF key and observe:

1234567890/^QWERTYUIOP]+ASDFGHJKL;]\@ZXCVBNM,.-

□

10. While holding SHIFT key depressed, type !"#\$\$%&'()=?^\_\*:[\@<>\_TEST TEST and observe:

1234567890/^QWERTYUIOP]+ASDFGHJKL;]\@ZXCVBNM,.-

!"#\$\$%&'()=?^\_\*:[\@<>\_TEST TEST □

11. Depress RETURN and LF keys. Depress and hold the 1 key; while holding it down type 2222. Observe on third line of screen:

12222 □

12. Depress RETURN and LF keys again. Depress CAPS LOCK key and type 0^][\@

Observe on fourth line:

0^][\@ □

13. Depress RETURN and LF keys again. Type from numeric pad 0.123456789 and observe on fifth line:

0.123456789 □

Deactivate CAPS LOCK key.

14. If this test failed at any step, go to auxiliary device procedure in subsection 7.1.8. If no auxiliary device is available, faulty ORU is keyboard (40) or PWA (1).

If auxiliary device procedure has been executed properly, faulty ORU is PWA. If it has not been executed properly, faulty ORU is keyboard. If further resolution is required, go to subsection 7.1.10.

7.1.5 Keyboard Test (Upper and Lowercase)

This procedure is for terminals having an upper and lowercase display. If the terminal being tested does not have the upper and lowercase display, go on to subsection 7.1.6.

HONEYWELL PROPRIETARY AND CONFIDENTIAL

1. Depress CLR key. Deactivate CAPS LOCK key if depressed.
2. If an auxiliary device is attached, manually return carriage and space paper up. Mark beginning of this test on paper; it will be important to be able to identify where this test began on auxiliary device.
3. Terminal should have blank screen with cursor in home position (top row, left margin).

NOTE

During the following steps, the operator should be sure that only one character is being displayed for each keystroke. A common keyboard failure mode is multiple characters displayed for a single keystroke. This failure is generally true for only one key at a time. If many characters are failing, this note should be ignored. However, if multiple characters are being displayed for each keystroke for a small number of keys (one or two), the keyboard is the faulty ORU.

4. Type from second keyboard row 1234567890/~ and observe that each character appears on top line as it is typed. Top line should appear as follows:

1234567890/~ □

5. Type qwertyuiop}+ and observe:

1234567890/~qwertyuiop}+ □

6. Type asdfghjkl;{ ' and observe:

1234567890/~qwertyuiop}+asdfghjkl;{' □

7. Type `zxcvbnm,.- and observe:

1234567890/~qwertyuiop}+asdfghjkl;{'`zxcvbnm,.- □

8. Depress RETURN key and observe:

□1234567890/~qwertyuiop}+asdfghjkl;{'`zxcvbnm,.-

The cursor should have moved to the left margin of the screen covering the 1 and displaying it in inverse video. Freeze blinking cursor by depressing and holding break key (BRK) immediately after cursor blinks on. If inverse video is not proper, replace PWA. If depressing BRK fails to freeze cursor on, freeze cursor off by depressing BRK just as cursor blinks off. If cursor can be frozen either on or off, but not both, replace PWA. If cursor can not be frozen in either state, faulty ORU is either keyboard (5) or PWA (1).

9. Depress LF key and observe:

1234567890/~qwertyuiop}+asdfghjkl;{'`zxcvbnm,.-

□



## HONEYWELL PROPRIETARY AND CONFIDENTIAL

10. While holding SHIFT key depressed, type !"#%&'()=?^QWERTYUIOP]\*ASDFGHJKL:[\@ZXCVBNM<>\_BLANK BLANK and then depress RETURN and LF keys. Observe on top three lines of screen:  
1234567890/~qwertyuiop}+asdfghjkl;{!`zxcvbnm,.-  
!"#\$%&'()=?^QWERTYUIOP}\*ASDFGHJKL:[\@ZXCVBNM<>\_BLANK BLANK  
□
11. Depress and hold the l key; while holding it down type 2222. Observe on third line of screen:  
12222 □
12. Depress RETURN and LF keys again. Depress CAPS LOCK key and type 0^][\@  
Observe on fourth line:  
0^][\@ □
13. Depress RETURN and LF keys. Type from numeric pad 0.123456789 and observe on fifth line:  
0.123456789□  
Deactivate CAPS LOCK key.
14. If this test failed at any step, go to auxiliary device procedure in subsection 7.1.8. If no auxiliary device is available, faulty ORU is keyboard (40) or PWA (1).

If auxiliary device procedure has been executed properly, faulty ORU is PWA. If it has not been executed properly, faulty ORU is keyboard. If further resolution is required, go to subsection 7.1.10.

### 7.1.6 Special Function Test

This procedure may affect the auxiliary device in different ways depending on the type of device available (if any). For this procedure, the auxiliary device should be disabled since the output is not predictable.

1. Depress ESC and the ` key and observe that screen is cleared. If screen is not cleared, replace keyboard.
2. Depress ESC and the 4 key and then fill screen with @ symbol. If background mode is not correct for each character position, replace PWA.
3. Depress HOME key. Cursor should be at home position (top line, left margin). If it is not at home position, depress ESC, SHIFT, and H for alternate sequence.
4. Depress EOL key. Top line only should be blank. If it is not blank, depress ESC, SHIFT, and K keys for alternate sequence.
5. Depress SHIFT and EOP keys. Entire screen should now be blank. If it is not blank, depress ESC, SHIFT, and J keys for alternate sequence.

**HONEYWELL PROPRIETARY AND CONFIDENTIAL**

6. Type some displayable characters. Depress ESC and the 3 key and then some more displayable characters. If these characters are not displayed in normal mode video, replace PWA.
7. Depress HOME key. Depress and hold RPT and then depress ← key. Cursor should wrap around to lower right and continue to decrement column and row counters. If cursor does not move in this manner, depress HOME, ESC, SHIFT, and D keys for alternate sequence.
8. Depress HOME key. Depress and hold RPT and then depress → key. Cursor should increment column and row counters, and wrap around from end of last line to home position. If cursor does not move in this manner, depress HOME, ESC, SHIFT, and C keys for alternate sequence.
9. Depress HOME key. Depress and hold RPT and then depress ↑ key. Cursor should wrap around to row 24 and continue to decrement row counter. If cursor fails to move in this manner, depress HOME, ESC, SHIFT, and A keys for alternate sequence.
10. Depress HOME key. Depress and hold RPT and then depress ↓ key. Cursor should increment row counter and wrap around to first row when it reaches last row. If cursor fails to move in this manner, depress HOME, ESC, SHIFT, and B keys for alternate sequence.
11. If all primary functions failed but all alternatives worked, replace either the keyboard (5) or the PWA (1). If only one (or some) primary function(s) failed, but the alternate escape sequence(s) worked, replace the keyboard.
12. Depress ESC, f, o, and the SPACE bar. If cursor fails to move to last row, last column, replace PWA.
13. Depress CTL and the g Key. If audio alarm does not sound, depress CTL and the m key. If cursor returns to column 1, replace PWA. If cursor did not move, replace keyboard.
14. Depress ESC, ff, and SPACE bar. Type testing123 and then depress the LF and RETURN keys:
  - a. If audio alarm is enabled for keyboard input (see Figure 9-1) and alarm did not sound on input of s in testing123.
  - b. If cursor is not in the first column of the second row, replace PWA.
15. Depress LF and RETURN keys. Alternately depress ESC and each of the 15 function keys (i.e., each key of the top row, plus ERASE key) starting with CLR, going right to XMIT and then ERASE. Observe:

```
'0268:<>DABCHiK □
```

**NOTE**

If terminal does not have the lowercase option, will be @ and i will be I.

## HONEYWELL PROPRIETARY AND CONFIDENTIAL

16. Now, with SHIFT held depressed, repeat step 13 and remember NOTE in step 15 while observing.  
'1579;=?DABCHiJ □
17. Depress CLR. Fill top two lines with data so that cursor is near the right end of line 2. While holding repeat key depressed, depress XMIT and note cursor activity. While repeat key is still held depressed, position LINE/PAGE switch on front panel to its alternate setting and again note cursor activity. If cursor does not scan from (near) beginning of line and page, depending on switch setting, replace PWA. If cursor begins at only either line or page, faulty ORU is either PWA switch or the attached cable. Return switch to original position.
18. Depress CLR and DEL keys. If cursor is not in home position, replace keyboard (10) or PWA (1).
19. Depress 4, ESC, f, SP, and the 7 key. Screen will have a 4 in home position and cursor in column 1 of last line. Depress LF key. If screen is now blank (4 having rolled up, off screen), ROLL/PAGE switch in rear of unit should be in ROLL position. If this switch is in PAGE position, replace logic PWA. Similarly, if 4 remains on screen and switch is in ROLL position, replace logic PWA.

If further resolution is required, refer to subsection 7.1.10.

### 7.1.7 Non-Local Tests

This subsection includes tests of the VIP7200 transmit/receive circuitry. The first test requires a special plug or piece of test equipment; the remaining tests require a remote station.

#### 7.1.7.1 Loopback

Perform the following procedures for the loopback test.

1. If current loop interface is to be tested, proceed to subsection 7.1.7.2. If a device (such as a properly jumpered connector plug) which connects pin 2 to pin 3 and pin 4 to pins 6 and 8 is not available, proceed to subsection 7.1.7.2.
2. Turn off unit. Replace data set connector with test device. Configure switches as follows: On Line, Character, Full Duplex and Echoplex. Turn on unit.
3. If all three lights on front panel are not on, faulty ORU is either PWA light or connected cable.
4. Type displayable data keys. If no data appears on screen, replace PWA.
5. Place unit in half-duplex mode. If Clear To Send and Data Set Ready lights do not go out, replace PWA. Type displayable data keys. If Data Set Ready does not light, replace PWA.

## HONEYWELL PROPRIETARY AND CONFIDENTIAL

6. Depress END OF MESSAGE key. If Data Set Ready light does not remain off for as long as key is held depressed, replace either keyboard (5) or PWA.
7. If further resolution is required, refer to subsection 7.1.10.
8. If these steps passed, the EIA interface circuitry of the PWA is working properly. Turn off unit. Reinstall data set cable and turn on unit. Return switches to original setting.

### 7.1.7.2 Transmit to Remote Station

If a remote station is not available, go on to auxiliary device procedure in subsection 7.1.8. Run on-line diagnostic (subsection 7.2) or key in simple data set to a host computer as follows:

1. Set switches to appropriate setting to transmit to remote station via site's modem.
2. Set ON LINE/LOCAL switch to ON LINE.
3. Disconnect auxiliary device as it may not be able to operate at new baud rate.
4. Repeat appropriate keyboard test (upper or upper and lowercase). The remote station should verify the result of the test and report its finding.
5. If this procedure has failed, PWA may be faulty ORU. However, before replacing PWA, check modem and communication line since they have a greater probability of failure than PWA.

### 7.1.7.3 Receive from Remote Station

Run on-line diagnostic (see subsection 7.2) or receive simple data set from a host computer as follows:

1. Set switches to appropriate settings to receive from remote station via site's modem.
2. Ask remote station to repeat appropriate keyboard test (upper or upper and lowercase) and special function test. Verify result of test on terminal screen.
3. If this procedure has failed, PWA may be faulty ORU. However, before replacing PWA, check modem and communication line since they have a greater probability of failure than PWA.

### 7.1.8 Auxiliary Device

This subsection shows how the auxiliary device printout should look for the video line control and keyboard test procedures. After comparing the printouts with these samples, return to and continue with the original fault diagnosis procedure which leads to this subsection. Consider that this procedure failed if the auxiliary device printouts do not match these samples.

## HONEYWELL PROPRIETARY AND CONFIDENTIAL

This procedure may have been reached without being referenced by a previous fault diagnosis procedure; i.e., all previous tests were executed without detecting an error. In this case, if the printouts do not match these samples (assuming the auxiliary device to be operating properly), the faulty ORU is the PWA.

### 7.1.8.1 Video Line Control

The auxiliary device printout for this procedure should match the sample following the text in this subsection.

Actual printouts will depend on the type of auxiliary device. Printer functionality which will make actual printouts different from those given in this section are:

1. Automatic LF/RETURN. Length and depth of lines will depend on the print position at which the auxiliary unit provides the LF/RETURN.
2. Escape Sequence Handling. If printer does not respond to escape sequences, the ESC character will be ignored but the second character of the sequence will be printed. For example, PRU1001 printers will print ` each time CLR is depressed on the keyboard.

Printouts for this section were obtained with a PRU1003 auxiliary unit optioned to provide the automatic LF/RETURN at print position 80. PRU1003 and PRU1005 printers recognize escape sequences.



7.1.8.2 Mini Keyboard Test

The auxiliary device printout for this procedure should match the following sample: 248A

NOTE

The first character of the next four samples in subsections 7.1.8.3 and 7.1.8.4 may be overstruck, depending on how the auxiliary printer reacts to the depression of the 7200 break key. If this first character is overstruck, the second line will be indented one position.

7.1.8.3 Keyboard Test (Uppercase)

The auxiliary device printout for this procedure should match this sample if the auxiliary device prints only uppercase:

```
1234567890/^QWERTYUIOP]+ASDFGHJKL;[\@ZXCVBNM,.-
! "#$%&'()=?^]*:[\@<>_TEST TEST
12222
0^][[\@
0.123456789
```

The auxiliary device printout for this procedure should match this sample if the auxiliary device prints both upper and lowercase:

```
1234567890/~qwertyuiop}+asdfghjkl;{|\`zxcvbnm,.-
!"#$%&'()=?^]*:[\@<>_TEST TEST
12222
0^][[\@
0.123456789
```

7.1.8.4 Keyboard Test (Upper and Lowercase)

The auxiliary device printout for this procedure should match this sample if the auxiliary device prints only uppercase:

```
1234567890/^QWERTYUIOP]+ASDFGHJKL;[\@ZXCVBNM,.-
! "#$%&'()=?^QWERTYUIOP]*ASDFGHJKL;[\@RXCVBNM<>_BLANK BLANK
12222
0^][[\@
0.123456789
```

## HONEYWELL PROPRIETARY AND CONFIDENTIAL

The auxiliary device printout for this procedure should match this sample if the auxiliary device prints both upper and lowercase:

```
Q234567890/~qwertyuiop}+asdfghjkl;{|\`zxcvbnm,.-
!"#$%&'()*=?^GWERTYUIOP]*ASDFGHJKL:[\@ZXCVBNM<>_BLANK BLANK
12222
0^][\@
0.123456789
```

### 7.1.9 Where To Go From Here

If the transmit to remote station, receive from remote station, or auxiliary device tests are not executed because these facilities are not available, the problem may be on the PWA as a small portion of the circuitry on the board is not used in local mode. However, the circuitry that was not checked is much less likely to cause a problem than the modem or the communication line itself. Therefore, the units external to the terminal should be verified before any ORU is replaced.

### 7.1.10 FER Procedures

This subsection provides the FER with further testing procedures to enable him to identify a faulty ORU with greater confidence.

#### 7.1.10.1 Isolation of PWAs and CRT Display Chassis

Depress CLR key and fill screen with @ sign. Then, measure the voltages to the CRT display chassis at the 5- and 7-pin HASL connectors. Using an oscilloscope, check the following waveforms:

- Video (pin 5 HASL05 connector)
- Horizontal sync (pin 6 HASL07 connector)
- Vertical sync (pin 4 HASL05 connector).

The proper waveforms are given in Section XI of this manual.

The video may be forced by grounding function DVIDEO-00 (chip location K14, pin 11). If this pin is grounded, all Ones are forced on the screen (a complete raster). On the other hand, if CVIDEO+01 (chip location K14, pin 13) is grounded, all Zeros are written and the screen is blank (no raster and no cursor).

If the voltages and waveforms are correct, the faulty ORU is the CRT display chassis. If the voltages and waveforms are not correct, continue with subsection 7.1.10.3.

#### 7.1.10.2 Isolation of Keyboard and PWAs

First retry test with another, known-to-be-working keyboard, if available. If failure persists, continue with subsection 7.1.10.3. If failure is resolved, replaced keyboard is faulty. When another keyboard is not available, continue with this subsection.



## HONEYWELL PROPRIETARY AND CONFIDENTIAL

Measure the voltages to the keyboard at A10. Check the waveforms with an oscilloscope:

- Sync on the keyboard strobe
- Look at the keyboard data lines or dc function line of interest.

Type whatever key is suspected to be malfunctioning. While scoping the data lines or dc function line, record the data pattern. Refer to the keyboard and function pad output codes table (Section XI) and verify the data pattern, or that the dc function line of interest goes to Zero when key is depressed.

If the voltages and waveforms are correct, the faulty ORU is either the logic PWA or the power supply PWA. If further resolution is desired, continue with subsection 7.1.10.3. If the voltages and waveforms are not correct, continue with subsection 7.1.10.3.

### 7.1.10.3 Isolation of Power Supply PWA and Logic PWA

If the voltage checks in subsections 7.1.10.1 or 7.1.10.2 are not correct, check the power supply output voltages at the 8-pin HASL connector on the logic PWA. The voltage values should correspond to those given in Section XI.

If the power supply voltages do not correspond to those in Section XI, disconnect the HASL08 connector on the logic PWA and recheck the voltages. If the voltages are correct after the cable has been disconnected, replace the logic PWA. If the voltages are still incorrect, the problem is either the power supply PWA (8) or the transformer (1). In this case, check transformer T1 voltages. The voltage values should correspond to those given in Figure 7-1. If the transformer voltages do not correspond to those given in Figure 7-1, disconnect the secondary (unload the windings) and recheck these voltages. If the voltages are now correct, replace the power supply PWA. If the voltages are still incorrect after the secondary has been disconnected, replace the transformer.

If the power supply voltages at the HASL08 connector do correspond to those in Section XI (without removing the cable), disconnect the CRT display chassis and the keyboard. Recheck the voltage that was failing prior to entering this test. If the voltage is now correct, the faulty ORU is either the keyboard or the CRT display chassis depending on which interface has had the incorrect voltage. If the voltage is still incorrect, replace the logic PWA.

### 7.1.10.4 Isolation of PWA and Front Panel Lights and Switches

Turn off power and remove the cover. Disconnect the front panel cable from the PWA.

1. Lights. With an ohmmeter set to a high scale, test for an open circuit condition from pin 6 (positive ohmmeter probe) to pins 8, 9, and 10. If any are open, replace corresponding LED. Otherwise, replace PWA.

2. Switches. Table 7-1 gives the relationship of switch settings to the open/short state of pairs of cable pins. With an ohmmeter, test for the condition of the desired (or all) switch position(s). If any reading is not valid, install a new switch. Otherwise, replace PWA.

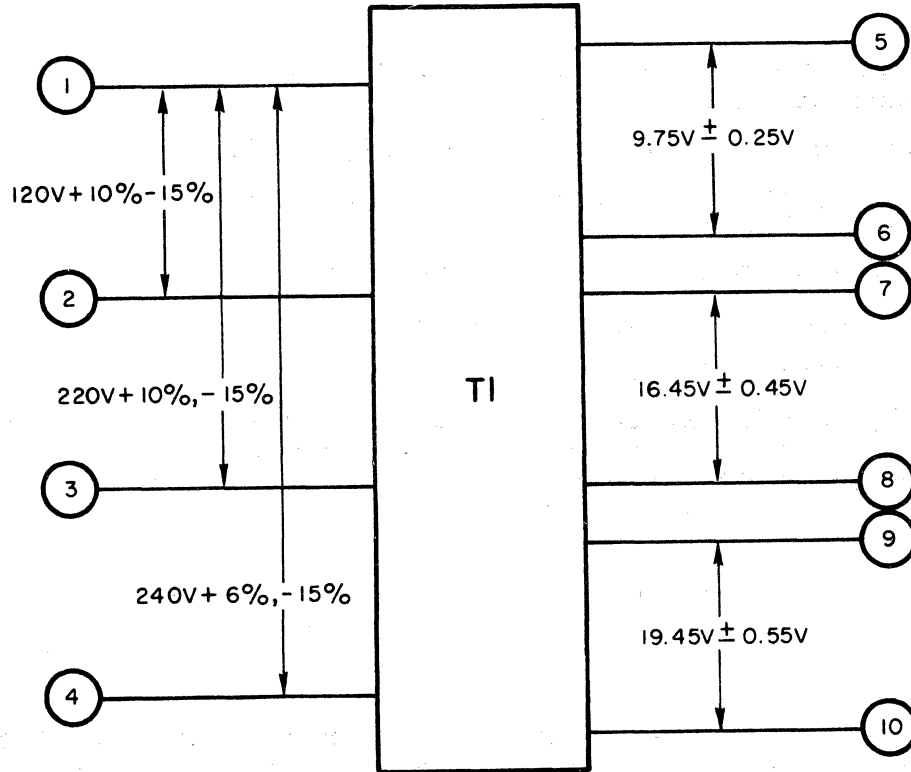

Figure 7-1 Power Transformer Voltages

Table 7-1 Switch Setting and Cable Pair Relationships

| SWITCH POSITION TRUE | SHORTED CABLE PINS | OPEN CABLE PINS   |
|----------------------|--------------------|-------------------|
| Character Buffered   | 2, 7               | 2, 7              |
| Page Line            | 4, 7               | 5, 7              |
| Local                | 5, 7               | 4, 7              |
| On Line              | 11, 15 and 14, 13  | 1, 15 and 12, 13  |
|                      | 1, 15 and 12, 13   | 11, 15 and 14, 13 |

## 7.2 OFF-LINE AUXILIARY DEVICE TEST

### 7.2.1 VIP7200/PRU1001 Interaction Test

The following procedure is designed to provide a partial check of the interface between a VIP7200 and a PRU1001 printer. The printer is configured as a read-only auxiliary device and is connected to the extension part of the VIP unit.

1. Before exercising printer from VIP keyboard, perform following.
  - a. Complete printer and VIP local tests described in subsection 7.1.
  - b. Ensure that printer is properly cabled to VIP unit.
  - c. Ensure that baud rate and parity select switches of both units are same.
2. Set VIP7200 LOCAL COPY/ECHOPLEX switch to LOCAL COPY.
3. Set VIP LOCAL/ON LINE switch to LOCAL.
4. Set printer to READY.
5. Type U\* on VIP keyboard. If printer does not print U\*, problem is in one of three areas: extension part logic of VIP logic PWA, cable, or auxiliary printer.

#### NOTE

A VIP can be substituted as the auxiliary device by cabling the extension part into the data set connector port of the auxiliary VIP. Set the auxiliary VIP to ON LINE.

6. If auxiliary device replacement is not practical to aid isolation, monitor voltage levels of pins 7, 4, 20, and 2 of extension port after unplugging it from printer. Pins 4 and 20 should be -12 Vdc with respect to pin 7 (ground). While holding REPEAT key depressed, type U and monitor voltage and waveform at pin 2. With REPEAT key still depressed, type \* and recheck pin 2. If the voltages and waveforms are correct, faulty unit is either auxiliary printer or auxiliary device interface cable.

### 7.2.2 VIP7200/PRU1003/PRU1005 Interaction Test

The following procedure is designed to provide a partial check of the interface between a VIP7200 and a PRU1003 or PRU1005 printer. The printer is configured as a read-only auxiliary device and is connected to the extension port of the VIP unit.

1. Before exercising printer from VIP keyboard, perform following:
  - a. Complete printer and VIP local tests described in subsection 7.1.
  - b. Ensure that printer is properly cabled to VIP unit.

HONEYWELL PROPRIETARY AND CONFIDENTIAL

- c. Ensure that baud rate, stop bit count and parity select switches of both units are same.
2. Set VIP7200 LOCAL COPY/ECHOPLEX switch to LOCAL COPY.
3. Set VIP LOCAL/ON LINE switch to LOCAL.
4. Set printer to READY.
5. Type U\* on VIP keyboard. If printer does not print U\*, problem is in one of three areas: extension port logic of the VIP logic PWA, cable, or auxiliary printer.

NOTE

A VIP can be substituted as the auxiliary device by cabling the extension port into the data set connector port of the auxiliary VIP. Set the auxiliary VIP to ON LINE.

6. If auxiliary device replacement is not practical to aid isolation, monitor voltage levels of pins 7, 4, 20, and 2 of extension port after unplugging it from printer. Pins 4 and 20 should be -12 Vdc with respect to pin 7 (ground). While holding REPEAT key depressed, type U and monitor voltage and waveform at pin 2. With REPEAT key still depressed, type \* and recheck pin 2. If voltages and waveforms are correct, faulty unit is either auxiliary printer or auxiliary device interface cable.
7. Type in data characters and ensure that column counter indicator number is one more than number of characters typed.

NOTE

The following step (power down/up cycle destroys all previously set vertical and horizontal tabs.

8. Power down printer and power up again. Do not activate Vertical Format Units (VFU) punched paper tape mechanism if installed. Depress START/STOP pushbutton to put printer on line and illuminate ON LINE indicator. Position paper so that print head is ready to start at line 1 immediately beneath form crease.
9. While holding CTL key depressed, type g (ASCII bell code) on VIP keyboard. Printer audible alarm should sound.
10. While holding CTL key depressed, type k (ASCII vertical tab code). Printer should advance paper by 66 lines.
11. While holding CTL depressed, type letter l (ASCII form feed code). Printer should again advance paper by 66 lines. If step 10 or 11 failed to cause printer to advance 66 lines, printer is faulty.
12. Type l and depress RETURN key. Line l is identified (see Figure 7-2).
13. Depress ESC key and type 0. While holding CTL key depressed, type f. Form size is now set to six lines.

**HONEYWELL PROPRIETARY AND CONFIDENTIAL**

14. While holding CTL key depressed, type k. Type 7 and depress RETURN key. Print tabs to line 7 (line 1 of six-line form).
15. Depress LF key three times. Type 10 and depress RETURN key. Printer advances to line 10 (line 4 of six-line form).
16. Depress ESC key and type 3. Printer sets tab to current line (line 4).
17. While holding CTL key depressed, type letter l. Type 13 and depress RETURN key. Printer form feeds to next form.
18. While holding CTL key depressed, type k. Type 16 and depress RETURN key. Vertical tab for printer moves down three lines.
19. Depress ESC key and type 4 to clear vertical tabs for printer.
20. While holding CTL key depressed, type letter l. Type 19 and depress RETURN key. Printer form feeds.
21. While holding CTL key depressed, type k. Type 25 and depress RETURN key. Printer should feed six lines.
22. While holding CTL key depressed, type i. Printer tabs to right margin.
23. Type + and depress SPACE bar. Depress RETURN key. Printer performs a LF/CR to line 26.
24. Depress ESC key and type 111. Printer sets horizontal tab at current position (column 1).
25. Depress ESC key and type 122. Printer sets horizontal tab at current position (column 3).
26. Depress ESC key and type 133. Printer sets horizontal tab at current position (column 5).
27. Depress ESC key and type 144. Printer sets horizontal tab at current position (column 7).
28. Depress ESC key and type 155. Printer sets horizontal tab at current position (column 9).
29. Depress ESC key and type 166. Printer sets horizontal tab at current position (column 11).
30. Depress ESC key and type 177. Printer sets horizontal tab at current position (column 13).
31. Depress ESC key and type 188. Printer sets horizontal tab at current position (column 15)..
32. Depress ESC key and type 199. Printer sets horizontal tab at current position (column 17).
33. Depress ESC key and type 100. Printer sets horizontal tab at current position (column 19).
34. Depress ESC key and type 111. Printer sets horizontal tab at current position (column 21).

HONEYWELL PROPRIETARY AND CONFIDENTIAL

35. Depress ESC key and type 122. Printer sets horizontal tab at current position (column 23).
36. Depress ESC key and type 133. Printer sets horizontal tab at current position (column 25).
37. Depress ESC key and type 144. Printer sets horizontal tab at current position (column 27).
38. Depress ESC key and type 155. Printer sets horizontal tab at current position (column 29).
39. Depress ESC key and type 166. Printer sets horizontal tab at current position (column 31).
40. Depress LF and RETURN keys.
41. While holding CTL key depressed and using keypad numerals, type 1i2i3i4i5i6i7i8i9i0ili2i3i4i5i6i (column indicator should be 032).
42. While holding CTL key depressed, type i. Release CTL key and type +. Column indicator should be 081 or 133.
43. Depress ESC key and type 2. Printer clears tabs.
44. Depress RETURN key. Column indicator should be 001.
45. While holding CTL key depressed, type i. Column indicator should be 080 or 132.
46. While holding CTL key depressed, type h. Depress RPT key. Column indicator should backspace.
47. Off-line test of printer is complete. Check output results with Figure 7-2. Any discrepancy indicates a faulty printer.

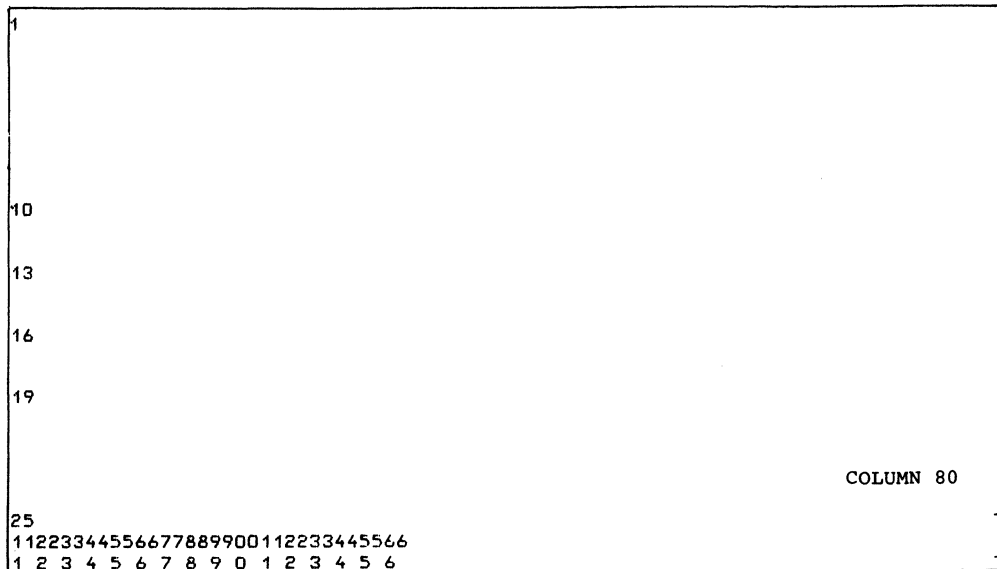

Figure 7-2 VIP7200/PRU1003/PRU1005 Interaction Test

**7.3 ON-LINE DIAGNOSTIC PROCEDURE**

Not available for this issue.

**7.4 VIP7200 TEST AND DIAGNOSTICS SPECIFICATION**

Not available for this issue.

**7.5 TEST AND VERIFICATION INSTRUCTIONS**

Not available for this issue.

# VIII MAINTENANCE

This section contains instructions for replacing the following Optimum Replaceable Units (ORUs).

- Keyboard
- Terminal logic PWA
- Power supply PWA
- CRT display chassis
- Power transformer.

Refer to Section VII for the fault diagnosis procedures which may be used to identify a faulty ORU.

This section also provides internal adjustment procedures for the CRT display assembly.

**WARNING**

Hazardous voltages are present within the terminal.  
To avoid electrical shock, disconnect power cord  
before removing cover.

## 8.1 COVER REMOVAL AND REPLACEMENT

To remove the terminal cover, perform the following procedure.

1. Observe WARNING at beginning of this section.
2. Remove the two screws and flat washers from extreme upper right and left corners on back of terminal.



## HONEYWELL PROPRIETARY AND CONFIDENTIAL

3. Grasping cover on each side, lift back edge enough to disengage front lip from base and pull cover forward, approximately 2 inches. Then, reach inside and unplug front panel wiring harness from connector P13 on terminal logic PWA. Cover can now be completely removed from terminal.
4. Replace cover by reversing removal procedure.

### 8.2 KEYBOARD REPLACEMENT

To replace the keyboard, disconnect the keyboard ribbon cable from connector J3 at the back of the terminal. Then, connect the cable attached to the replacement keyboard in its place.

### 8.3 TERMINAL LOGIC PWA REPLACEMENT

To replace the terminal logic PWA, perform the following procedure.

1. Unplug terminal power cable.
2. Remove cover (see subsection 8.1), observing WARNING at beginning of this section.
3. At back of terminal, disconnect any cables that may be connected to J1 (data set), J2 (extension part), or J3 (keyboard).
4. Inside terminal, disconnect P7 from J7 and P12 from J12. P7 is located on top of logic PWA and P12 is on top of power supply PWA.
5. Remove three screws which attach back edge of logic PWA to terminal base.
6. At front edge of logic PWA, remove screws at each of the two PWA supports and lift PWA off.
7. Slide PWA forward slightly and out to right (as seen from front of terminal).
8. Disassemble power supply PWA from logic PWA by removing the six screws, nuts, and spacers and unplugging P14 from J14 on logic PWA.
9. On the replacement logic PWA, set switches at PWA locations L06/M13, K10/B04, and J16/K14 (see Figure 9-1) to agree with those on PWA just removed.
10. At back edge of replacement PWA, set all of operator-accessible switches to agree with those on PWA being replaced.
11. Install replacement PWA by reversing above removal procedure. Do not replace cover yet.
12. Plug in terminal power cord and turn terminal on. Adjust brightness and contrast as directed in subsection 8.6.1.

## HONEYWELL PROPRIETARY AND CONFIDENTIAL

13. Perform checkout procedure described in subsection 9.4.
14. Replace terminal cover.

### 8.4 POWER SUPPLY PWA REPLACEMENT

To replace the power supply PWA, perform the following procedure.

1. Remove logic PWA with attached power supply from terminal (refer to subsection 8.3, steps 1 through 7).
2. Remove power supply PWA from logic PWA (refer to subsection 8.3, step 8) except unplug connector P1 from J1 on the power supply PWA.
3. Install replacement power supply PWA by reversing above removal procedure. Do not replace terminal cover yet.
4. Perform adjustment and checkout procedures given in steps 11, 12, and 13 of subsection 8.3.

### 8.5 CRT DISPLAY CHASSIS REPLACEMENT

To replace the CRT display chassis, perform the following procedure.

1. Unplug terminal power cable.
2. Remove cover (see subsection 8.1) observing WARNING at beginning of this section.
3. Disconnect P21 from CRT circuit board.
4. Disconnect ground wire from E03GD on CRT display chassis.
5. At front of terminal, remove the two screws and flat washers which attach chassis to terminal base.
6. At back of terminal, remove the two screws, lock-washers, and flat washers which attach chassis to terminal base. Hold onto chassis to prevent it from falling onto PWA as screws are removed.
7. Install replacement CRT display chassis by reversing above removal procedure. Do not replace the cover yet.
8. Plug in terminal power cord and turn terminal on. Adjust brightness and contrast as directed in subsection 8.6.1.
9. Replace cover on terminal.

### 8.6 CRT DISPLAY ADJUSTMENTS

The adjustments given in this subsection may be required following replacement of the CRT display chassis or the terminal PWA. These adjustments are made with the CRT display chassis installed in the terminal and with the terminal on and displaying a full screen of characters.

### 8.6.1 Contrast Adjustment

To adjust the contrast, perform the following procedure.

#### NOTE

The brightness control should be adjusted at a point where the white raster is just extinguished. The CRT will then be at its cutoff point, and a maximum contrast ratio can be obtained.

1. Turn terminal on.
2. Display an uppercase letter H on screen.
3. At left side of PWA as seen from front of terminal, adjust contrast control (see Figure 8-1) until the horizontal line in the H protrudes out to right as shown below.

H

4. Back contrast adjustment off until this protrusion just disappears, and then continue to back the adjustment off another half turn.

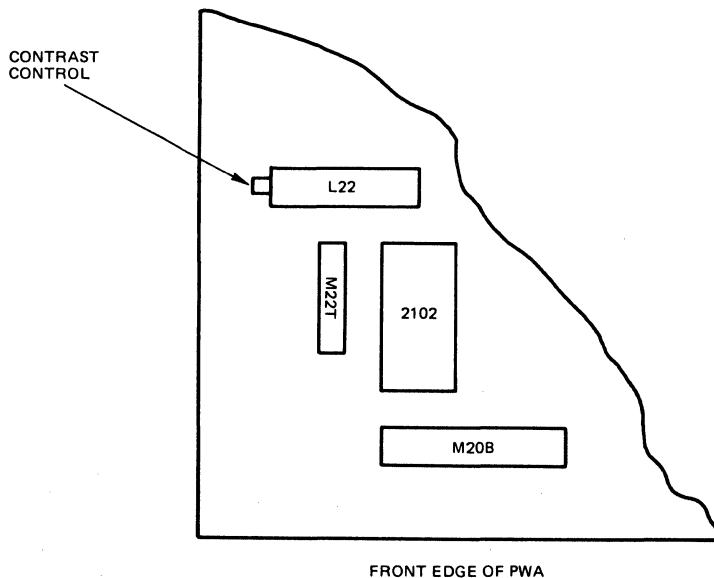

Figure 8-1 Location of Contrast Control

### 8.6.2 Vertical Adjustment

There is a slight interaction among the vertical frequency, height, and linearity controls. For example, a change in the height of the image may affect linearity.

1. Apply video and synchronization signals to CRT display (display a full screen of characters).
2. Set vertical frequency control (R116, Figure 8-2) near mechanical center of its rotation.

3. Adjust vertical height control (R124) for desired height.
4. Adjust vertical linearity control (R121) for best vertical linearity.
5. Remove vertical drive signal from CRT display or, alternatively, use a short jumper lead to short vertical drive input terminal of printed circuit card edge connector to ground.
6. Readjust vertical frequency control (R116) until picture rolls up slowly.
7. Restore vertical drive to CRT display.
8. Recheck height and linearity.

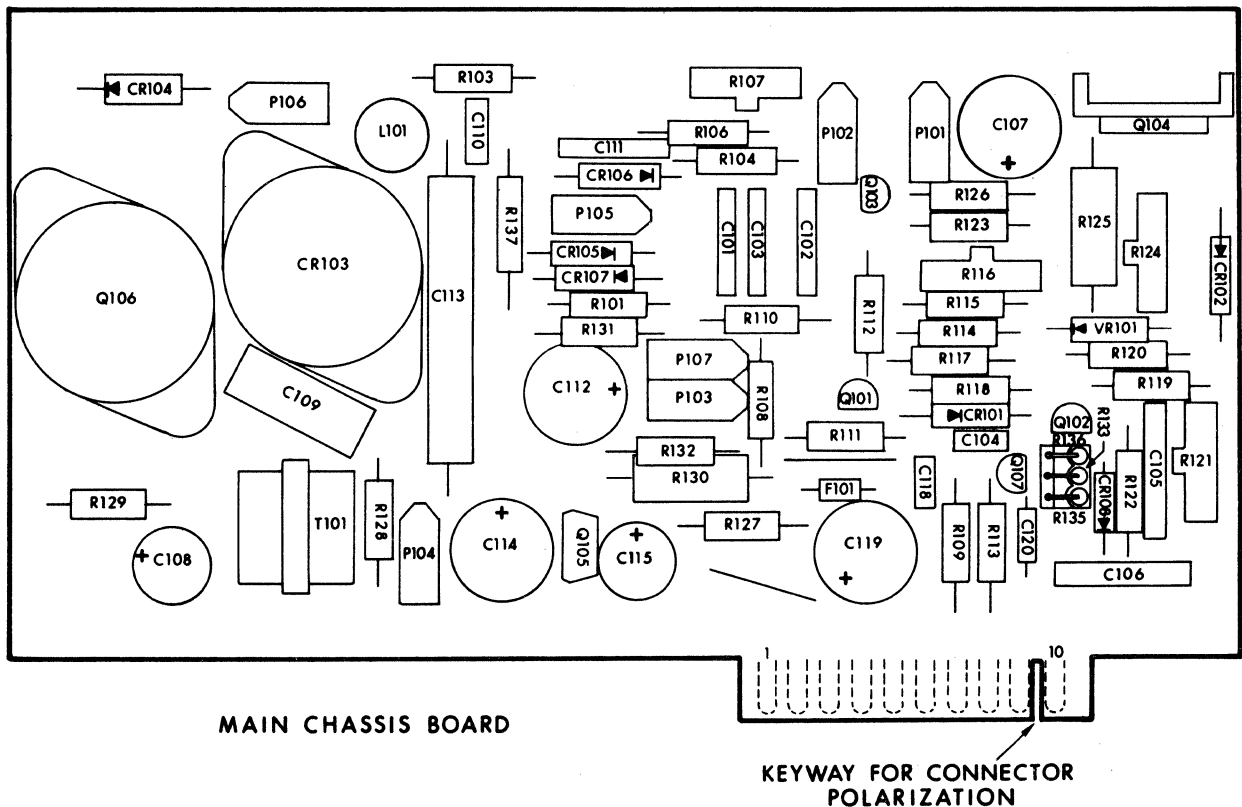

Figure 8-2 Location of Adjustments on CRT Circuit Board

### 8.6.3 Horizontal Adjustments

Raster width is affected by a combination of the low voltage supply, the width coil (L101, Figure 8-2), and the horizontal linearity sleeve located on the neck of the CRT beneath the yoke.

## HONEYWELL PROPRIETARY AND CONFIDENTIAL

1. Apply video and synchronization signals to CRT display (display a full screen of characters).
2. Insert horizontal linearity sleeve about two-thirds of its length under yoke. If sleeve is inserted farther than necessary, excessive power will be consumed and horizontal output circuitry could be overstressed.
3. Adjust horizontal width coil (L101) for a width of 9 inches.
4. Insert linearity sleeve farther under yoke to obtain best linearity. Although this adjustment will affect raster width, it should not be used solely for that purpose. Placement of linearity sleeve should be optimized for best linearity.
5. Readjust L101 for a display width of 9 inches.
6. Observe final horizontal linearity and width, and touch up either adjustment if needed.

No horizontal hold control is used on the CRT display. The raster should be properly locked and centered by the horizontal drive signals provided by the terminal PWA.

### 8.6.4 Focus Adjustment

The focus control (R107, Figure 8-2) provides an adjustment for maintaining best overall display focus. However, because of the construction of the gun assembly in the CRT, this control does not have a large effect on the focus.

### 8.6.5 Centering Adjustment

If the raster is not properly centered, it may be repositioned by rotating the ring magnets behind the deflection yoke.

#### NOTE

The ring magnets should not be used to offset the raster from its nominal center position because it would degrade the resolution of the display.

If the display is tilted, rotate the entire yoke.

## 8.7 TRANSFORMER T1 REPLACEMENT

To replace transformer T1, perform the following procedure.

1. Unplug terminal power cord.
2. Remove cover (see subsection 8.1) observing WARNING at beginning of this section.
3. Disconnect P11 from J11 (between transformer and POWER switch).
4. Disconnect P12 from J12 on power supply PWA.
5. Disconnect transformer ground wire at E01GD on transformer ground plate.

**HONEYWELL PROPRIETARY AND CONFIDENTIAL**

6. Disconnect P12 ground wire at E02GD on transformer ground plate.
7. Remove the four screws and nuts, and eight flat washers which attach transformer and ground plate to terminal base.
8. Install replacement transformer by reversing above removal procedure. Be sure to reconnect all of ground wires to E01GD and E02GD as follows.
  - a. E01GD: ground from power plug P12 and ground from transformer T1.
  - b. E02GD: ground from power switch S1, ground from E03GD on CRT display chassis, and ground from connector P12.

# IX INSTALLATION

## 9.1 GENERAL

This section provides instructions for the installation of the VIP7200 series of video display terminals. Several modes of line procedure and modem protocols are available. The installing field engineer should select and follow the set of procedures that are appropriate to the particular type of installation. The procedures vary primarily in the way the terminal is configured by the setting of internal and external switches.

## 9.2 RECEIVING AND UNPACKING

No special tools or handling procedures are required to unpack the terminal. Exercise care while transporting and unpacking to avoid damaging the terminal. As soon as the terminal has been unpacked, inspect it carefully. Report to the carrier immediately if any damage is found.

## 9.3 GENERAL INSTALLATION PROCEDURE

This subsection provides a universal installation procedure which may be used to install the terminal in any application for which it is suitable. This procedure involves predetermining all of the host system's interface requirements, and then configuring and installing the terminal to be compatible with these requirements.

### 9.3.1 Preliminary Installation Data Requirements

The configuration of the terminal is flexible and is determined by the user's requirements. All pertinent information should be determined through prior coordination with the user, and should be

## HONEYWELL PROPRIETARY AND CONFIDENTIAL

furnished to the field engineer at the time of installation. This information must include:

1. Types, quantities, and locations of all equipment to be installed, including auxiliary devices to terminals.
2. Types of interface to host system:
  - a. EIA through modem or modem bypass
  - b. 20-mA current loop direct connection
  - c. 20-mA current loop direct connection.
3. Distance to host system or modem.
4. Communication line operating speed.
5. Mode of operation:
  - a. Full-duplex (echoplex)
  - b. Half-duplex (full-duplex with local copy)
  - c. Two-way alternate (half-duplex, 202 data set).
6. Character structure:
  - a. Ten bits: 1 start, 7 data, 1 parity, and 1 stop (odd or even parity)
  - b. Ten bits: 1 start, 7 data, parity, and stop.
  - c. Eleven bits: 1 start, 7 data, 1 parity, and 2 stop (odd or even parity).
7. Determine if host system software supports block transmission modes of transfer, and if so which of the following end-of-transmission characters are to be used:
  - a. ETX (end of text)
  - b. EOT (end of transmission)
  - c. CR (carriage return).
8. Determine if host system software supports both uppercase and lowercase transmissions.
9. Determine if user wants end-of-line warning alarm.
10. Determine if user wants cursor to blink.
11. Determine if host system supports 7-bit or 8-bit ASCII code.

### 9.3.2 Installation

Use the information gathered in subsection 9.3.1 to properly configure the terminal as described in the following steps.

1. Position terminal in its assigned location. Space requirements and other physical data are given in Section I of this manual.
2. Remove cover from terminal (see subsection 8.1).



## HONEYWELL PROPRIETARY AND CONFIDENTIAL

3. Refer to Figure 9-1 and find switches at locations B04, K14, and M13 for PWA 60130734 or K10, J16, and L06 for PWA 60130705.
4. Switches 6 and 8 at PWA location B04/K10 and STOP BIT slide switch on back of terminal are used to configure character structure. Select required character structure from Table 9-1 and set switches as indicated.
5. Set switches 4 and 6 at PWA location K14/J16 to EIA or current loop depending on type of communication interface required. If current loop is used, also set switch 2 to 20 mA or 60 mA as required. Set switch 4 of B04/K10 as appropriate.
6. Set switches 1, 3, 5, and 7 at PWA location B04/K10 as directed in Table 9-2 to select required end-of-message character for block mode transmissions.
7. If host system software supports full 128-character set of ASCII codes (upper and lowercase characters), set switch 8 at PWA location K14/J16 to upper/lowercase. If software does not support lowercase, set this switch to uppercase.
8. Set switches 1, 3, 5, and 7 at PWA location K14/J16 to agree with input power frequency to terminal (50 Hz or 60 Hz).
9. For European/UK installations where high/low alternate baud rate switching is used, set switch 2 at PWA location B04/K10 to enable position.
10. If an end-of-line warning alarm is required, set switch 8 at PWA location M13/L06 to enable position.
11. If blink feature for cursor is required, set switch 4 at PWA location M13/L06 to enable position.
12. Set switch 2 at PWA location M13/L06 to appropriate position to support host system software of either 7-bit ASCII code or 8-bit ASCII code.
13. Replace cover on terminal.
14. Install keyboard ribbon cable (shipped connected to the keyboard) to connector J3 of back of terminal.
15. Install an interface cable between host system (or modem) and connector J1 on back of terminal.
  - a. If EIA RS232C interface is required, connect terminal to host system via modem or modem bypass using 10-foot modem cable (part number 59B400394G10A) provided. Cables up to 50 feet in length may be used for this type of interface connection.
  - b. If current loop interface is required, connect terminal to host system using appropriate cable. Pin assignments for this cable are provided in Figure 3-10. Cables up to 1000 feet in length may be used for this type of interface connection.

HONEYWELL PROPRIETARY AND CONFIDENTIAL

NOTE

The host system must provide the power source for the current loop interface.

16. If an auxiliary device is to be connected to terminal extension port, refer to subsection 9.5 for installation instructions.
17. At back of terminal, set BAUD RATE switch for required communication line operating speed. Switch settings and their corresponding baud rates are:

| SWITCH<br>SETTING | BAUD<br>RATE |
|-------------------|--------------|
| 2                 | 75           |
| 3                 | 110          |
| 5                 | 150          |
| 6                 | 300          |
| 7                 | 600          |
| 9                 | 1200         |
| 10                | 1800         |
| 11                | 2400         |
| 13                | 4800         |
| 15                | 9600         |

18. Set HALF/FULL DUPLEX switch to proper position for mode of operation required.
19. For European/UK installations, set MODEM SPEED switch to HI or LO as dictated by operational speed of system. For U.S. applications this switch has no effect.
20. Set LOCAL COPY/ECHO switch to the proper position for the required mode of operation. Plug terminal power cord into an appropriate electrical receptacle.
21. Verify proper operation of terminal by performing checkout procedure in subsection 9.4.

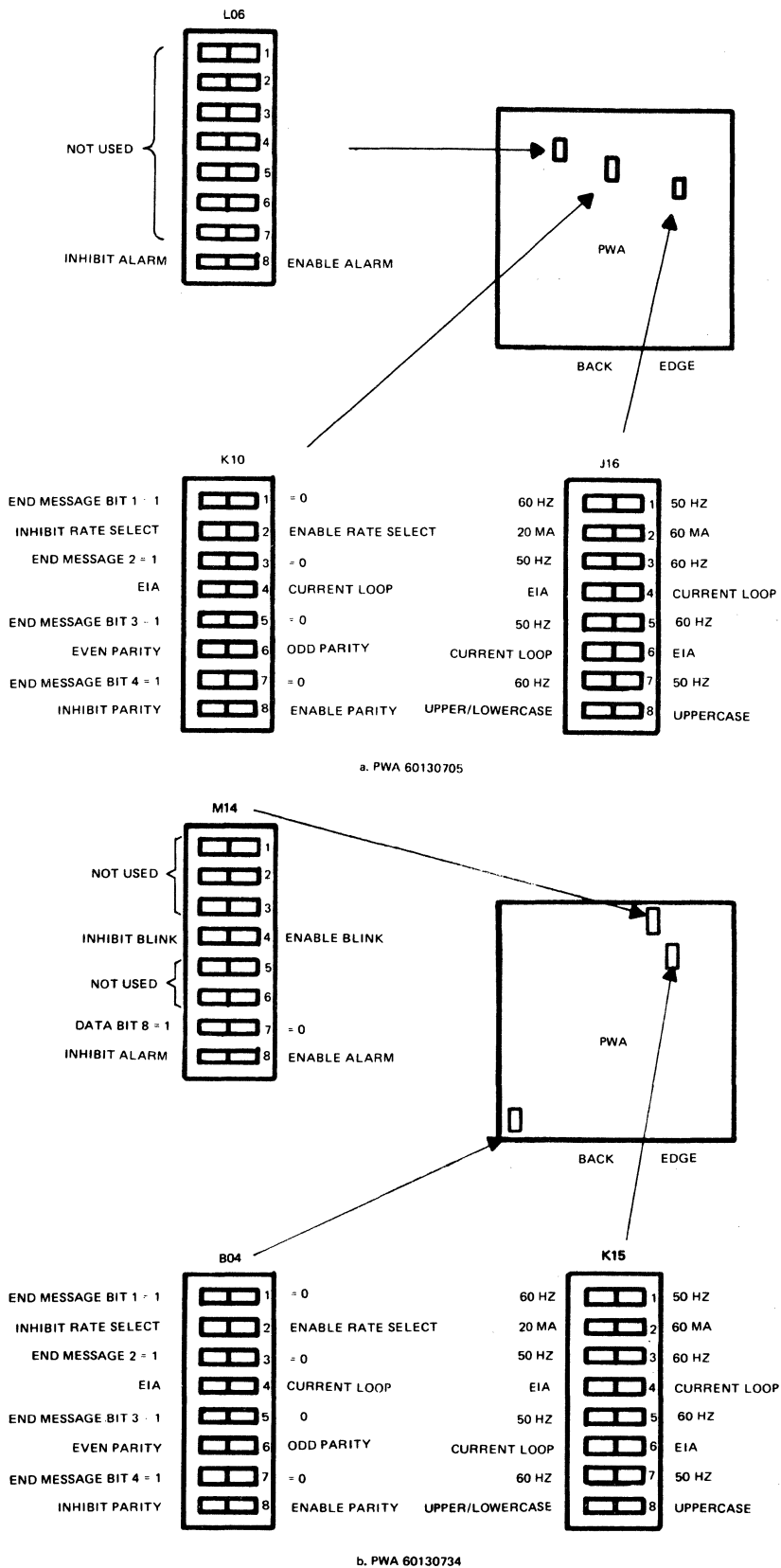

Figure 9-1 Internal Switches

**HONEYWELL PROPRIETARY AND CONFIDENTIAL**

Table 9-1 Character Structure Configuration

| CHARACTER STRUCTURE   | SWITCH SETTINGS   |          |
|---|---|----------|
|   | PWA LOCATION K10  | STOP BIT |
| 10 bits: 1 start, 7 data, 1 parity (odd or even), and 1 stop. | Set switch 8 to Enable Parity and switch 6 to even or odd for type of parity required.                  | 1        |
| 10 bits: 1 start, 7 data, and 2 stop (mark parity).           | Set switch 8 to Inhibit Parity. If mark parity is required, first stop bit will act as mark parity bit. | 2        |
| 11 bits: 1 start, 7 data, 1 parity (odd or even), and 2 stop. | Set switch 8 to Enable Parity and switch 6 to even or odd for type of parity required.                  | 2        |

Table 9-2 End-of-Message Character Configuration

| END-OF-MESSAGE CHARACTER | SWITCH SETTINGS AT PWA LOCATION K10 |          |          |          |
|--------------------------|-------------------------------------|----------|----------|----------|
|                          | SWITCH 7                            | SWITCH 5 | SWITCH 3 | SWITCH 1 |
| NUL                      | 0                                   | 0        | 0        | 0        |
| ETX                      | 0                                   | 0        | 1        | 1        |
| EOT                      | 0                                   | 1        | 0        | 0        |
| LF                       | 1                                   | 0        | 1        | 0        |
| CR                       | 1                                   | 1        | 0        | 1        |

9.4 INSTALLATION OF AUXILIARY DEVICES

A variety of auxiliary input and/or output devices can be connected to the host system through the terminal extension port (connector J2). However, before any auxiliary device is selected, two prerequisites must be satisfied:

1. The device must be capable of meeting the auxiliary interface requirements specified in subsection 9.4.1.
2. The host system supporting software must be capable of controlling the auxiliary device as described in subsection 9.4.2.

A partial list of possible auxiliary devices is given in Table 9-3.

**HONEYWELL PROPRIETARY AND CONFIDENTIAL**

**9.4.1 Auxiliary Device Requirements**

The auxiliary device must meet the following requirements in order to operate properly when connected to the terminal extension port.

1. The auxiliary device must have an EIA RS232C type of interface, or must be equipped with an option to provide this interface.
2. It must be capable of operating in a two-way, simultaneous mode.
3. It must be capable of operating with the same data rate, character structure, and parity as the terminal.

**9.4.2 Host System Requirements**

In general, the supporting software must be aware of the auxiliary device characteristics since the level of support required may be different from that required by the terminal. For example, when data is sent to a terminal with an unbuffered printer attached as an auxiliary device, a time delay is required following a carriage return/line feed. Also, supporting software must manage any inconsistencies in control characters or functions used by the terminal and auxiliary device. For example, terminal control characters used for cursor forward space, cursor backspace, and clear screen functions may not be compatible with the use of these control characters by the auxiliary device.

Table 9-3 Auxiliary Devices and Cables

| AUXILIARY DEVICE* | REQUIRED CABLES |      |     |
|-------------------|-----------------|------|-----|
|                   | PART NO.**      | TYPE | QTY |
| TermiNet 300      | 59B400394-xxx   | W3   | 2   |
|                   | 59B400546Gxxx   | W8   | 1   |
| TermiNet 1200     | 59B400394-xxx   | W3   | 2   |
|                   | 59B400564Gxxx   | W8   | 1   |
| VIP7100           | 59B400394-xxx   | W3   | 2   |
|                   | 59B400564Gxxx   | W8   | 1   |
| VIP7200           | 59B400394-xxx   | W3   | 2   |
|                   | 59B400564Gxxx   | W8   | 1   |

\*The auxiliary devices may not necessarily be compatible with the host system supporting software (refer to subsection 9.4.2).

\*\*The xxx indicates the numbers which specify cable length; for example, 050 specifies a 50-foot cable. The total maximum length which can be used for the auxiliary device interface is 50 feet.

### 9.4.3 Installation

After ascertaining that the auxiliary device will operate compatibly with the host system and the terminal to which it will be attached (as described in subsections 9.4.1 and 9.4.2), install the auxiliary device to the terminal as follows.

1. Refer to installation procedures given in instruction manual for auxiliary device and use them as necessary in conjunction with the following steps.
2. Place auxiliary device in location where it is to be used. Maximum interconnecting distance for EIA interface is 50 feet.
3. Install interface cable between auxiliary device and extension port (connector J2) on back of terminal. Cables for some commonly used auxiliary devices are specified in Table 9-3. If necessary, refer to interface diagram (Figure 3-11) to identify pin assignments for interface cable.
4. Configure baud rate, character structure (9, 10, or 11 bits), and parity of auxiliary device to match those of terminal.
5. Auxiliary interface does not provide Data Set Ready or Clear to Send signals. If auxiliary device requires these signals, strap corresponding interface leads in auxiliary device.
6. If auxiliary device has its own on-line/local mode selection, set it to receive from terminal.
7. Plug auxiliary device into an appropriate electrical receptacle.
8. Turn on terminal and auxiliary device and check out auxiliary device as recommended in its installation or operating instructions.

### 9.5 CHECKOUT

Perform the following checkout procedures to ensure that the terminal is ready for normal operation.

1. Turn POWER switch to ON. Allow approximately 1 minute for display to warm up.

#### NOTE

The audible alarm usually (but not always) beeps as the switch is turned on indicating that power has been applied to the PWA. If the alarm is not heard, turn the switch off and then on again (several times if necessary) to find out if the alarm sounds.

2. Check to see that cursor is displayed on screen. It should appear at left margin of top line.
3. Place ON LINE/LOCAL switch (located on the front panel) in LOCAL position and ECHO/LOCAL COPY switch in LOCAL COPY position.

**HONEYWELL PROPRIETARY AND CONFIDENTIAL**

4. Check for proper operation of terminal by operating each key on keyboard and observing display for proper response at desired baud rate or rates. If any improper responses are observed, perform fault diagnosis procedures given Section VII.
5. With data displayed on screen, adjust BRIGHTNESS control to obtain a satisfactory display intensity under ambient light conditions. Normally, it should be adjusted at a point where white raster is just extinguished. CRT will then be at its cutoff point, and a maximum contrast ratio should be obtained.
6. If necessary, adjust height control and width coil for desired raster height and width, and focus control to produce optimum focus over entire area of screen. Refer to Section VIII for these adjustment procedures.
7. Place ON LINE/LOCAL switch in the ON LINE position and repeat step 4. Ensure to take appropriate steps to protect data in host system during this procedure.

**X**  
**ILLUSTRATED**  
**PARTS**  
**CATALOG**

This section contains the parts lists and applicable drawings for the VIP7200 major assemblies listed in Table 10-1.



**HONEYWELL PROPRIETARY AND CONFIDENTIAL**

Table 10-1 VIP7200 Major Assemblies

| ASSEMBLY   | PARTS LIST/<br>DRAWING NO. | SEE<br>PAGE |
|--|----------------------------|-------------|
| <b>CRT TERMINAL ASSEMBLY:</b>                            |                            |             |
| VIP7200 Terminal, 60-Hz, Uppercase Only                  | BTRM901A                   | 10-3        |
| VIP7200 Terminal, 60-Hz, Uppercase and<br>Lowercase      | BTRM902A                   | 10-3        |
| VIP7200 Terminal, 50-Hz, Uppercase Only                  | BTRM801A                   | 10-4        |
| VIP7200 Terminal, 50-Hz, Uppercase and<br>Lowercase      | BTRM802A                   | 10-4        |
| CRT Terminal Assembly, 69-Hz,<br>Uppercase Only          | 60131971-001               | 10-5        |
| CRT Terminal Assembly, 60-Hz,<br>Uppercase and Lowercase | 60131971-002               | 10-5        |
| CRT Terminal Assembly, 50-Hz,<br>Uppercase Only          | 60131971-003               | 10-5        |
| CRT Terminal Assembly, 50-Hz,<br>Uppercase and Lowercase | 60131971-004               | 10-5        |
| CRT Display Chassis Assembly                             | 59733709-002               | 10-11       |
| CRT Circuit Board Assembly                               | 6-002-0530                 | 10-12       |
| BP2TYC Power Supply Board Assembly                       | 60130541-001               | 10-15       |
| BP2TYC Assembly Pictorial                                | 60130541-101               | 10-17       |
| BE2TS2 Logic Board Assembly                              | 60130702-001               | 10-19       |
| BE2TS2 Assembly Pictorial                                | 60130702-101               | 10-23       |
| BE2TCY Logic Board Assembly                              | 60130730                   | 10-25       |
| BE2TCY Assembly Pictorial                                | 60130730-102               | 10-29       |
| <b>KEYBOARD ASSEMBLY</b>                                 |                            |             |
| Keyboard Assembly  | BKBD002A                   | 10-30       |
| Keytops for Keyboard                                     | 60129887-004               | 10-30       |
|  | -                          | 10-33       |
| CABLE, W3, 10-FOOT                                       | 59B400394-010              | 10-34       |

HONEYWELL PROPRIETARY AND CONFIDENTIAL

THE INFORMATION CONTAINED IN THIS DOCUMENT IS PROPRIETARY TO HONEYWELL INFORMATION SYSTEMS INC. AND IS INTENDED FOR INTERNAL HONEYWELL USE ONLY. SUCH INFORMATION MAY BE DISTRIBUTED TO OTHERS ONLY BY WRITTEN PERMISSION OF AN AUTHORIZED HONEYWELL OFFICIAL. THIS RESTRICTION DOES NOT APPLY TO VENDORS SUPPLYING MATERIALS TO HONEYWELL.

| ITEM NO. | P C | IDENTIFICATION NO. | S C | DRAWING TITLE      | ASSEMBLY/QUANTITY |     |     | U M |
|----------|-----|--------------------|-----|--------------------|-------------------|-----|-----|-----|
|          |     |                    |     |                    | 001               | 002 | 003 |     |
| 1        | TD  | 60131971-002       | A   | CRT TERMINAL ASSY  | 1                 | 1   | 1   | EA  |
| 2        | T   | 60130541-001A      | D   | BP2TYC ASSEMBLY    | 1                 | 1   | 1   | EA  |
| 3        | T   | 60130702-002B      | A   | BE2TS2 ASSY        | 1                 | -   | -   | EA  |
| 4        | TB  | 59302315-005       | P   | NAME PLATE RATING  | 1                 | 1   | 1   | EA  |
| *        | T   | 60130702-003C      | A   | BE2TS2 ASSY        | -                 | 1   | -   | EA  |
| *        | T   | 60130702-004D      | A   | BE2TS2 ASSY        | -                 | -   | 1   | EA  |
| *        | TX  | 60133842-001       | A   | MOD KIT VIP 7200   | 1                 | 1   | 1   | EA  |
| *        | A   | 60133843-000       | D   | MOD INSTR VIP 7200 | X                 | X   | X   | EA  |

**Honeywell**  
HONEYWELL INFORMATION SYSTEMS  
LOC. BILLERICA, MASSACHUSETTS, USA.

UM - UNIT OF MEASURE  
EA - EACH  
CM - CENTIMETER  
G - GRAMS

IN - INCHES  
OZ - OUNCE

TITLE  
TRML U/LC 60HZ

SIZE TX P.L. NO. BTRM902A SHEET 1/ REV. E

\* ITEMS REVISED SINCE REV. D

98 99  
DOES A DOCUMENT REVISION STATUS SHEET EXIST?  YES

S = SUBSTITUTE PARTS

THE INFORMATION CONTAINED IN THIS DOCUMENT IS PROPRIETARY TO HONEYWELL INFORMATION SYSTEMS INC. AND IS INTENDED FOR INTERNAL HONEYWELL USE ONLY. SUCH INFORMATION MAY BE DISTRIBUTED TO OTHERS ONLY BY WRITTEN PERMISSION OF AN AUTHORIZED HONEYWELL OFFICIAL. THIS RESTRICTION DOES NOT APPLY TO VENDORS SUPPLYING MATERIALS TO HONEYWELL.

| ITEM NO. | P C | IDENTIFICATION NO. | S C | DRAWING TITLE     | ASSEMBLY/QUANTITY |     |     | U M |
|----------|-----|--------------------|-----|-------------------|-------------------|-----|-----|-----|
|          |     |                    |     |                   | 001               | 002 | 003 |     |
| 1        | TD  | 60131971-001       | A   | CRT TERMINAL ASSY | 1                 |     |     | EA  |
| 2        | T   | 60130541-001A      | D   | BP2TYC ASSEMBLY   | 1                 |     |     | EA  |
| *        | T   | 60130702-005E      | A   | BE2TS2 ASSY       | 1                 |     |     | EA  |
| 4        | TB  | 59302315-005       | P   | NAME PLATE RATING | 1                 |     |     | EA  |

**Honeywell**  
HONEYWELL INFORMATION SYSTEMS  
LOC. BILLERICA, MASSACHUSETTS, USA.

UM - UNIT OF MEASURE  
EA - EACH  
CM - CENTIMETER  
G - GRAMS

IN - INCHES  
OZ - OUNCE

TITLE  
TRML UC 60HZ

SIZE TX P.L. NO. BTRM901A SHEET 1/ REV. B

\* ITEMS REVISED SINCE REV. A

98 99  
DOES A DOCUMENT REVISION STATUS SHEET EXIST?  YES

S = SUBSTITUTE PARTS

HONEYWELL PROPRIETARY AND CONFIDENTIAL

THE INFORMATION CONTAINED IN THIS DOCUMENT IS PROPRIETARY TO HONEYWELL INFORMATION SYSTEMS INC. AND IS INTENDED FOR INTERNAL HONEYWELL USE ONLY. SUCH INFORMATION MAY BE DISTRIBUTED TO OTHERS ONLY BY WRITTEN PERMISSION OF AN AUTHORIZED HONEYWELL OFFICIAL. THIS RESTRICTION DOES NOT APPLY TO VENDOR PROPRIETARY PARTS THAT MAY BE INCLUDED IN THIS DOCUMENT.

|   |    |               |   | 770819              |     | SIZE              | BTRM001A | SHEET | REV. |
|---|----|---------------|---|---------------------|-----|-------------------|----------|-------|------|
|   |    |               |   | 001                 | 002 | ASSEMBLY/QUANTITY |          |       | U    |
| 1 | TD | 60131971-003  | A | CRT TERMINAL ASSY   | 1   | 1                 |          |       | EA   |
| 2 | T  | 60130941-001A | D | BP2TYC ASSEMBLY     | 1   | 1                 |          |       | EA   |
| 3 | T  | 60130702-009E | A | BE2TS2 ASSY         | 1   | 1                 |          |       | EA   |
| 4 | TB | 99902315-001  | P | NAME PLATE RATING   | 1   | 1                 |          |       | EA   |
| 5 | A  | 03910222-001  | V | LABEL, P.S., SERIAL | 1   | 1                 |          |       | EA   |
| 6 | TX | 60133837-001  | A | INST KIT UoK.       | -   | -                 | 1        |       | EA   |

**Honeywell**  
HONEYWELL INFORMATION SYSTEMS  
LOC. BILLERICA, MASSACHUSETTS, USA.

UM - UNIT OF MEASURE  
EA - EACH                      IN - INCHES  
CM - CENTIMETER            OZ - OUNCE  
G - GRAMS

\* ITEMS REVISED SINCE REV. 0

TITLE  
TRML UC 30HZ

SIZE TX    P.L. NO. BTRM001A    SHEET 1/    REV. C

10 001 DOES A DOCUMENT REVISION STATUS SHEET EXIST?  YES    S = SUBSTITUTE PARTS

THE INFORMATION CONTAINED IN THIS DOCUMENT IS PROPRIETARY TO HONEYWELL INFORMATION SYSTEMS INC. AND IS INTENDED FOR INTERNAL HONEYWELL USE ONLY. SUCH INFORMATION MAY BE DISTRIBUTED TO OTHERS ONLY BY WRITTEN PERMISSION OF AN AUTHORIZED HONEYWELL OFFICIAL. THIS RESTRICTION DOES NOT APPLY TO VENDOR PROPRIETARY PARTS THAT MAY BE INCLUDED IN THIS DOCUMENT.

|   |    |               |   | 770815             |     |     | SIZE              | BTRM002A | SHEET | REV. |
|---|----|---------------|---|--------------------|-----|-----|-------------------|----------|-------|------|
|   |    |               |   | 001                | 002 | 003 | ASSEMBLY/QUANTITY |          |       | U    |
| 1 | TD | 60131971-004  | A | CRT TERMINAL ASSY  | 1   | 1   | 1                 |          |       | EA   |
| 2 | T  | 60130941-001A | D | BP2TYC ASSEMBLY    | 1   | 1   | 1                 |          |       | EA   |
| 3 | T  | 60130702-002B | A | BE2TS2 ASSY        | 1   | -   | -                 |          |       | EA   |
| 4 | TB | 59902315-001  | P | NAME PLATE RATING  | 1   | 1   | 1                 |          |       | EA   |
| 5 | T  | 60130702-003C | A | BE2TS2 ASSY        | -   | 1   | -                 |          |       | EA   |
| 6 | T  | 60130702-004D | A | BE2TS2 ASSY        | -   | -   | 1                 |          |       | EA   |
| 7 | TX | 60133842-001  | A | MCD KIT VIP 7200   | 1   | 1   | 1                 |          |       | EA   |
| 8 | A  | 60133843-000  | D | MCD INSTR VIP 7200 | X   | X   | X                 |          |       | --   |

**Honeywell**  
HONEYWELL INFORMATION SYSTEMS  
LOC. BILLERICA, MASSACHUSETTS, USA.

UM - UNIT OF MEASURE  
EA - EACH                      IN - INCHES  
CM - CENTIMETER            OZ - OUNCE  
G - GRAMS

\* ITEMS REVISED SINCE REV. 0

TITLE  
TRML U/LC 50HZ

SIZE TX    P.L. NO. BTRM002A    SHEET 1/    REV. E

10 001 DOES A DOCUMENT REVISION STATUS SHEET EXIST?  YES    S = SUBSTITUTE PARTS

HONEYWELL PROPRIETARY AND CONFIDENTIAL

THE INFORMATION CONTAINED IN THIS DOCUMENT IS PROPRIETARY TO HONEYWELL INFORMATION SYSTEMS INC. AND IS INTENDED FOR INTERNAL HONEYWELL USE ONLY. SUCH INFORMATION MAY BE DISTRIBUTED TO OTHERS ONLY BY WRITTEN PERMISSION OF AN AUTHORIZED HONEYWELL OFFICIAL. THIS RESTRICTION DOES NOT APPLY TO VENDORS OF PARTS TO BE USED IN THIS DOCUMENT.

|          |     |                    |     |                      | SIZE              |             |     |     |     | SHEET | REV. |
|----------|-----|--------------------|-----|----------------------|-------------------|-------------|-----|-----|-----|-------|------|
|          |     |                    |     |                      | 770930            | TD 60131971 |     |     |     | 1/5   | K    |
| ITEM NO. | P C | IDENTIFICATION NO. | S C | DRAWING TITLE        | ASSEMBLY/QUANTITY |             |     |     | U M |       |      |
|          |     |                    |     |                      | 001               | 002         | 003 | 004 |     |       |      |
| 1        | TC  | 60129810-001       | A   | BASE ASSY            | 1                 | 1           | 1   | 1   |     | EA    |      |
| 2        | TD  | 60129758-001       | A   | COVER ASSY           | 1                 | 1           | 1   | 1   |     | EA    |      |
| 3        | TC  | 60131962-001       | P   | FRONT COVER OVERLAY  | 1                 | 1           | 1   | 1   |     | EA    |      |
| 4        | A   | 59733709-002       | V   | CRT DISPLAY DES SPEC | 1                 | 1           | 1   | 1   |     | EA    |      |
| 5        | TC  | 60129862-002       | P   | CONN PANEL NO 1      | 1                 | 1           | 1   | 1   |     | EA    |      |
| 6        | TB  | 60129861-002       | P   | FUSE DECAL 60HZ      | 1                 | 1           | -   | -   |     | EA    |      |
| 7        | TB  | 60129882-001       | A   | GND PLATE ASSY       | 1                 | 1           | 1   | 1   |     | EA    |      |
| 8        | TC  | 60132083-001       | P   | CONN PANEL NO. 2     | 1                 | 1           | 1   | 1   |     | EA    |      |
| 9        | C   | 43134432-008       | V   | BUSHING              | 1                 | 1           | -   | -   |     | EA    |      |
| 10       | TK  | 60128558-001       | A   | CA 60HZ PWR CORD     | 1                 | 1           | -   | -   |     | EA    |      |
| 11       | A   | 04530220-001       | V   | TRANSFORMER          | 1                 | 1           | 1   | 1   |     | EA    |      |
| 12       | B   | 43168298-001       | V   | NUT BUSHING 6        | 2                 | 2           | 2   | 2   |     | EA    |      |
| 13       | A   | 43168065-007       | V   | BUMPER               | 5                 | 5           | 5   | 5   |     | EA    |      |
| 14       | A   | 70934301-001       | -   | SWITCH SLIDE         | 1                 | 1           | 1   | 1   |     | EA    |      |
| 15       | A   | 04670090-001       | V   | FUSE HOLDER          | 1                 | 1           | 2   | 2   |     | EA    |      |
| 16       | -   | 04670011-019       | V   | FUSE 1.0A 5B         | -                 | -           | 2   | 2   |     | EA    |      |

**Honeywell**  
HONEYWELL INFORMATION SYSTEMS  
LOC. BILLERICA, MASSACHUSETTS, USA.

UM - UNIT OF MEASURE  
EA - EACH IN - INCHES  
CM - CENTIMETER OZ - OUNCE  
G - GRAMS

TITLE  
**CRT TERMINAL ASSY**

|      |          |       |      |
|------|----------|-------|------|
| SIZE | P.L. NO. | SHEET | REV. |
| TD   | 60131971 | 1/5   | K    |

\* ITEMS REVISED SINCE REV. J

HS 85H  
DOES A DOCUMENT REVISION STATUS SHEET EXIST?  NO

S = SUBSTITUTE PARTS

THE INFORMATION CONTAINED IN THIS DOCUMENT IS PROPRIETARY TO HONEYWELL INFORMATION SYSTEMS INC. AND IS INTENDED FOR INTERNAL HONEYWELL USE ONLY. SUCH INFORMATION MAY BE DISTRIBUTED TO OTHERS ONLY BY WRITTEN PERMISSION OF AN AUTHORIZED HONEYWELL OFFICIAL. THIS RESTRICTION DOES NOT APPLY TO VENDORS OF PARTS TO BE USED IN THIS DOCUMENT.

|          |     |                    |     |                      | SIZE              |             |     |     |     | SHEET | REV. |
|----------|-----|--------------------|-----|----------------------|-------------------|-------------|-----|-----|-----|-------|------|
|          |     |                    |     |                      | 770930            | TD 60131971 |     |     |     | 2     | K    |
| ITEM NO. | P C | IDENTIFICATION NO. | S C | DRAWING TITLE        | ASSEMBLY/QUANTITY |             |     |     | U M |       |      |
|          |     |                    |     |                      | 001               | 002         | 003 | 004 |     |       |      |
| 17       | P   | 04170011-041       | V   | SLVG HEAT SHRINK SM  | 3                 | 3           | 6   | 6   |     | IN    |      |
| 18       | A   | 03820036-001       | V   | GUARD, FAN           | 1                 | 1           | 1   | 1   |     | EA    |      |
| 19       | P   | 03810008-002       | -   | VENTURI FAN          | 1                 | 1           | 1   | 1   |     | --    |      |
| 20       | P   | 04170011-026       | V   | SLVG HEAT SHRINK SM  | 10                | 10          | 10  | 10  |     | IN    |      |
| 22       | P   | 03010140-030       | V   | SCREW PAN HD SLOTTED | 4                 | 4           | 4   | 4   |     | EA    |      |
| 23       | P   | 03010140-036       | V   | SCREW PAN HEAD       | 4                 | 4           | 4   | 4   |     | EA    |      |
| 25       | P   | 03010140-035       | V   | SCREW PAN HD SLOTTED | 2                 | 2           | 2   | 2   |     | EA    |      |
| 26       | P   | 03010146-018       | V   | SCREW FH PHILIPS     | 2                 | 2           | 2   | 2   |     | EA    |      |
| 27       | P   | 03030004-001       | V   | NUT LW 4             | 2                 | 2           | 2   | 2   |     | EA    |      |
| 28       | P   | 03030004-003       | V   | NUT LW 8             | 4                 | 4           | 4   | 4   |     | EA    |      |
| 29       | P   | 03030004-004       | V   | NUT LW 6             | 16                | 16          | 16  | 16  |     | EA    |      |
| 30       | -   | 03020021-002       | V   | WASHER FL NON MTL C  | 5                 | 5           | 5   | 5   |     | EA    |      |
| 31       | P   | 03020038-003       | V   | WASHER FLAT          | 10                | 10          | 10  | 10  |     | EA    |      |
| 32       | P   | 03020038-004       | V   | WASHER FLAT          | 4                 | 4           | 4   | 4   |     | EA    |      |
| 33       | P   | 03020039-003       | V   | WASHER LOCK 6 STL    | 2                 | 2           | 2   | 2   |     | EA    |      |
| 34       | B   | 43168465-022       | V   | SWITCH CAP - WHITE   | 3                 | 3           | 3   | 3   |     | EA    |      |

**Honeywell**  
HONEYWELL INFORMATION SYSTEMS  
LOC. BILLERICA, MASSACHUSETTS, USA.

UM - UNIT OF MEASURE  
EA - EACH IN - INCHES  
CM - CENTIMETER OZ - OUNCE  
G - GRAMS

TITLE  
**CRT TERMINAL ASSY**

|      |          |       |      |
|------|----------|-------|------|
| SIZE | P.L. NO. | SHEET | REV. |
| TD   | 60131971 | 2     | K    |

\* ITEMS REVISED SINCE REV. J

HS 85H  
DOES A DOCUMENT REVISION STATUS SHEET EXIST?  NO

S = SUBSTITUTE PARTS

**HONEYWELL PROPRIETARY AND CONFIDENTIAL**

THE INFORMATION CONTAINED IN THIS DOCUMENT IS PROPRIETARY TO HONEYWELL INFORMATION SYSTEMS INC. AND IS INTENDED FOR INTERNAL HONEYWELL USE ONLY. SUCH INFORMATION MAY BE DISTRIBUTED TO OTHERS ONLY BY WRITTEN PERMISSION OF AN AUTHORIZED HONEYWELL OFFICIAL. THIS RESTRICTION DOES NOT APPLY TO VENDORS OR CONTRACTORS WHOSE INFORMATION MAY BE DISCLOSED IN THIS DOCUMENT.

| ITEM NO. | P C | IDENTIFICATION NO. | S C | DRAWING TITLE        | ASSEMBLY QUANTITY |       |       |       | U M |
|----------|-----|--------------------|-----|----------------------|-------------------|-------|-------|-------|-----|
|          |     |                    |     |                      | 001               | 002   | 003   | 004   |     |
| 35       | A   | 60067007-001       | -   | SWITCH TOGGLE 1 POLE | 2                 | 2     | 2     | 2     | --  |
| 37       | P   | 03020003-003       | V   | WASHER LOCK 6 STL    | 2                 | 2     | 2     | 2     | EA  |
| 38       | P   | 03020001-050       | V   | WASHER FLAT 8        | 4                 | 4     | 4     | 4     | EA  |
| 39       | B   | 59700061-001       | P   | LAMP                 | 3                 | 3     | 3     | 3     | EA  |
| 40       | A   | 03010002-009       | V   | SCREW PH 6           | 6                 | 6     | 6     | 6     | EA  |
| 41       | A   | 03010002-047       | V   | SCREW PH 6           | 6                 | 6     | 6     | 6     | EA  |
| 42       | D   | 60131981-001       | D   | SCHEM CRT TERMINAL   | X                 | X     | X     | X     | --  |
| 43       | TB  | 60131959-001       | P   | SPACER               | 3                 | 3     | 3     | 3     | EA  |
| 44       | TK  | 60131970-001       | A   | JL 60HZ CRT TERMINAL | 1                 | 1     | -     | -     | EA  |
| 45       | TK  | 60131977-001       | A   | JL PWR SUP TO LOGIC  | 1                 | 1     | 1     | 1     | EA  |
| 46       | TK  | 60128560-001       | A   | JL CRT TRANSFORMER   | 1                 | 1     | 1     | 1     | EA  |
| 47       | TK  | 60128553-001       | A   | CA PWB TO CRT        | 1                 | 1     | 1     | 1     | EA  |
| 48       | TK  | 60131982-001       | A   | CA CONTROL PANEL     | 1                 | 1     | 1     | 1     | EA  |
| 49       | A   | 60133843-000       | D   | MOD INSTR VIP 7200   | -                 | X     | -     | X     | --  |
| 50       | T   | 60130541-XXX       | A   | BP2TYC ASSY          | X                 | X     | X     | X     | EA  |
| 51       | -   | 43142270-008       | V   | CABLE CLAMP          | INTCH             | INTCH | INTCH | INTCH | EA  |

|  |   |                           |                            |                      |            |
|--|---|---------------------------|----------------------------|----------------------|------------|
| <b>Honeywell</b><br>HONEYWELL INFORMATION SYSTEMS<br>LOC. BILLERICA, MASSACHUSETTS, USA. | UM - UNIT OF MEASURE<br>EA - EACH<br>CM - CENTIMETER<br>G - GRAMS | IN - INCHES<br>OZ - OUNCE | TITLE<br>CRT TERMINAL ASSY |                      |            |
|  | * ITEMS REVISED SINCE REV. J                                      |                           | SIZE<br>TD                 | P.L. NO.<br>60131971 | SHEET<br>3 |

105 954  
DOES A DOCUMENT REVISION STATUS SHEET EXIST?  NO

S = SUBSTITUTE PARTS

THE INFORMATION CONTAINED IN THIS DOCUMENT IS PROPRIETARY TO HONEYWELL INFORMATION SYSTEMS INC. AND IS INTENDED FOR INTERNAL HONEYWELL USE ONLY. SUCH INFORMATION MAY BE DISTRIBUTED TO OTHERS ONLY BY WRITTEN PERMISSION OF AN AUTHORIZED HONEYWELL OFFICIAL. THIS RESTRICTION DOES NOT APPLY TO VENDORS OR CONTRACTORS WHOSE INFORMATION MAY BE DISCLOSED IN THIS DOCUMENT.

| ITEM NO. | P C | IDENTIFICATION NO. | S C | DRAWING TITLE        | ASSEMBLY QUANTITY |     |     |     | U M |
|----------|-----|--------------------|-----|----------------------|-------------------|-----|-----|-----|-----|
|          |     |                    |     |                      | 001               | 002 | 003 | 004 |     |
| 51       | A   | 70906156-001       | V   | TIE                  | 1                 | 1   | 1   | 1   | EA  |
| 52       | --  | 43142270-052       | V   | CABLE CLAMP          | 1                 | 1   | 1   | 1   | EA  |
| 53       | TB  | 59302315-XXX       | P   | NAMEPLATE RATING S/N | X                 | X   | X   | X   | EA  |
| 54       | TB  | 59300158-002       | P   | LABEL                | 1                 | 1   | 1   | 1   | EA  |
| 55       | P   | 03010140-033       | V   | SCREW PAN HD SLOTTED | 4                 | 4   | 4   | 4   | EA  |
| 56       | A   | 03910230-002       | V   | LABEL                | 1                 | 1   | 1   | 1   | EA  |
| 57       | TB  | 60131854-001       | A   | LABEL                | 1                 | 1   | 1   | 1   | EA  |
| 58       | A   | 60067007-028       | V   | SWITCH TOGGLE 2-POLE | 1                 | 1   | 1   | 1   | EA  |
| 59       | A   | 04370019-001       | V   | FILTER,RFI,SINGLE O  | 1                 | 1   | 1   | 1   | EA  |
| 60       | T   | 60130702-XXX       | A   | BE2TS2 ASSY          | X                 | X   | X   | X   | EA  |
| 61       | A   | 03910238-001       | V   | LABEL,WARNING        | 1                 | 1   | 1   | 1   | EA  |
| 62       | TB  | 60129886-001       | P   | FUSE DECAL 50HZ      | -                 | -   | 1   | 1   | EA  |
| 63       | TK  | 60128561-001       | A   | CA 50HZ PWR CORD     | -                 | -   | 1   | 1   | EA  |
| 64       | TK  | 60132119-001       | A   | JL 50HZ CRT TERMINAL | -                 | -   | 1   | 1   | EA  |
| 65       | TK  | 60132108-001       | A   | CA JUMPER PLUG TTY=C | 1                 | 1   | 1   | 1   | EA  |
| 66       | A   | 04670091-008       | V   | FUSE 2.0 A           | 1                 | 1   | -   | -   | EA  |

|  |   |                           |                            |                      |            |
|--|---|---------------------------|----------------------------|----------------------|------------|
| <b>Honeywell</b><br>HONEYWELL INFORMATION SYSTEMS<br>LOC. BILLERICA, MASSACHUSETTS, USA. | UM - UNIT OF MEASURE<br>EA - EACH<br>CM - CENTIMETER<br>G - GRAMS | IN - INCHES<br>OZ - OUNCE | TITLE<br>CRT TERMINAL ASSY |                      |            |
|  | * ITEMS REVISED SINCE REV. J                                      |                           | SIZE<br>TD                 | P.L. NO.<br>60131971 | SHEET<br>4 |

105 954  
DOES A DOCUMENT REVISION STATUS SHEET EXIST?  NO

S = SUBSTITUTE PARTS

HONEYWELL PROPRIETARY AND CONFIDENTIAL

THE INFORMATION CONTAINED IN THIS DOCUMENT IS PROPRIETARY TO HONEYWELL INFORMATION SYSTEMS INC. AND IS INTENDED FOR INTERNAL HONEYWELL USE ONLY. SUCH INFORMATION MAY BE DISTRIBUTED TO OTHERS ONLY BY WRITTEN PERMISSION OF AN AUTHORIZED HONEYWELL OFFICIAL. THIS RESTRICTION DOES NOT APPLY TO VENDORS PROPRIETARY INFORMATION THAT MAY BE DISCLOSED IN THIS DOCUMENT.

| ITEM NO.   | P<br>C | IDENTIFICATION NO. | S<br>C | DRAWING TITLE       | ASSEMBLY QUANTITY  |          |                            |      | U<br>M |  |
|--|--------|--------------------|--------|---------------------|--|----------|----------------------------|------|--------|--|
|  |        |                    |        |                     | 001  | 002      | 003                        | 004  |        |  |
| 67   | A      | 03050089-015       | V      | SPACER 6-32X1/4     | 2  | 2        | 2                          | 2    | EA     |  |
| 68   | P      | 03030029-002       | -      | NUT PLAIN HEX NYLON | 2  | 2        | 2                          | 2    | EA     |  |
| 69   | P      | 03020001-043       | V      | WASHER FLAT 6       | 4  | 4        | 4                          | 4    | EA     |  |
| 70   | P      | 03020005-004       | V      | WASHER INT TOOTH    | 2  | 2        | 2                          | 2    | EA     |  |
| 71   | A      | 03010002-013       | V      | SCREW PH 6          | 2  | 2        | 2                          | 2    | EA     |  |
| 72   | P      | 03020002-002       | V      | WASHER FLAT NYLON   | 2  | 2        | 2                          | 2    | EA     |  |
| 73   | A      | 60134086-001       | D      | INSTR MOD KIT U/C   | X  | -        | X                          | -    | EA     |  |
| 74   | A      | 03910251-001       | V      | LABEL-DIP SWITCH    | 1  | 1        | 1                          | 1    | EA     |  |
| * 74   | C      | 43134432-016       | P      | BUSHING             | -  | -        | 1                          | 1    | EA     |  |
| <b>Honeywell</b><br>HONEYWELL INFORMATION SYSTEMS<br>LOC. BILLERICA, MASSACHUSETTS, USA. |        |                    |        |                     | U.M. - UNIT OF MEASURE<br>EA - EACH                      IN - INCHES<br>CM - CENTIMETER            OZ - OUNCE<br>G - GRAMS |          | TITLE<br>CRT TERMINAL ASSY |      |        |  |
| * ITEMS REVISED SINCE REV. J   |        |                    |        |                     | SIZE   | P.L. NO. | SHEET                      | REV. |        |  |
|  |        |                    |        |                     | TD   | 60131971 | SF                         | K    |        |  |

48 034  
DOES A DOCUMENT REVISION STATUS SHEET EXIST?

NO

S = SUBSTITUTE PARTS

10-7/10-8

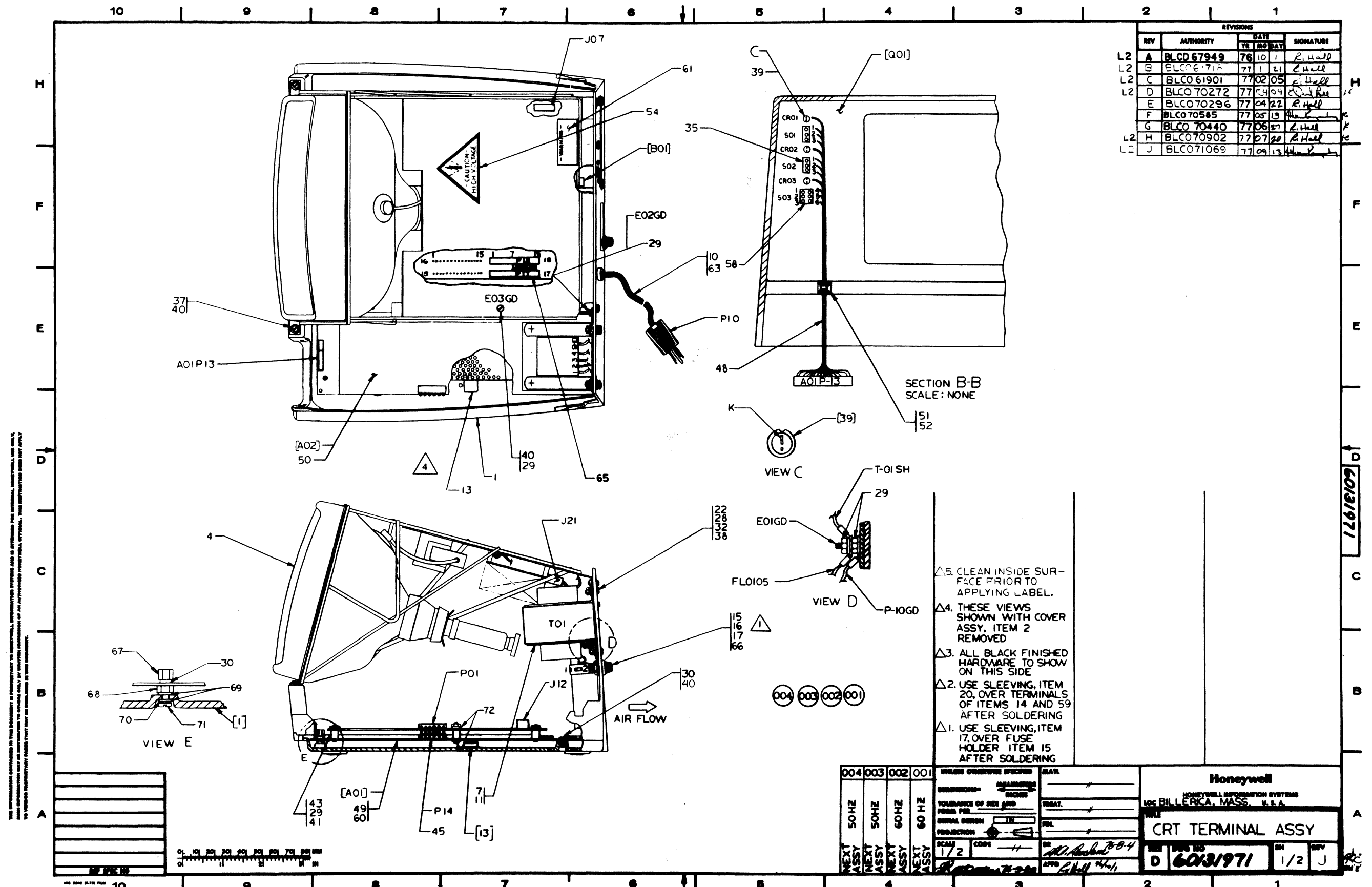

| REVISIONS |           |            |          |           |
|-----------|-----------|------------|----------|-----------|
| REV       | AUTHORITY | DATE       | BY       | SIGNATURE |
| L2        | A         | BLCO 67949 | 76 10 1  | R. Hall   |
| L2        | B         | BLCO 6716  | 77 1 21  | R. Hall   |
| L2        | C         | BLCO 61901 | 77 02 05 | R. Hall   |
| L2        | D         | BLCO 70272 | 77 04 04 | R. Hall   |
|           | E         | BLCO 70296 | 77 04 22 | R. Hall   |
|           | F         | BLCO 70585 | 77 05 13 | R. Hall   |
|           | G         | BLCO 70440 | 77 06 27 | R. Hall   |
| L2        | H         | BLCO 70902 | 77 07 20 | R. Hall   |
| L2        | J         | BLCO 71069 | 77 09 13 | R. Hall   |

THIS INFORMATION IS PROPRIETARY TO HONEYWELL INFORMATION SYSTEMS AND IS TO BE KEPT CONFIDENTIAL. IT IS TO BE USED ONLY FOR THE PURPOSES SPECIFIED IN THE ORDER. IT IS NOT TO BE REPRODUCED OR TRANSMITTED IN ANY FORM OR BY ANY MEANS, ELECTRONIC OR MECHANICAL, INCLUDING PHOTOCOPYING, RECORDING, OR BY ANY INFORMATION STORAGE AND RETRIEVAL SYSTEM.

|  |  |  |  |  |  |  |  |  |  |
|--|--|--|--|--|--|--|--|--|--|
|  |  |  |  |  |  |  |  |  |  |
|  |  |  |  |  |  |  |  |  |  |
|  |  |  |  |  |  |  |  |  |  |
|  |  |  |  |  |  |  |  |  |  |
|  |  |  |  |  |  |  |  |  |  |

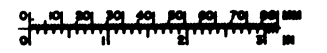

|           |      |           |      |                                    |      |
|-----------|------|-----------|------|------------------------------------|------|
| 004       | 003  | 002       | 001  | UNLESS OTHERWISE SPECIFIED         | MATL |
| NEXT ASSY | 50HZ | NEXT ASSY | 50HZ | FINISHES                           |      |
| NEXT ASSY | 50HZ | NEXT ASSY | 60HZ | TOLERANCE OF HOLE AND POSITION PER |      |
| NEXT ASSY | 60HZ | NEXT ASSY | 60HZ | FORM PER                           |      |
| NEXT ASSY | 60HZ | NEXT ASSY | 60HZ | DRILL DESIGN                       |      |
| NEXT ASSY | 60HZ | NEXT ASSY | 60HZ | PROJECTION                         |      |
| NEXT ASSY | 60HZ | NEXT ASSY | 60HZ | SCALE                              |      |
| NEXT ASSY | 60HZ | NEXT ASSY | 60HZ | CODE                               |      |
| NEXT ASSY | 60HZ | NEXT ASSY | 60HZ | DATE                               |      |
| NEXT ASSY | 60HZ | NEXT ASSY | 60HZ | APP                                |      |

**Honeywell**  
 HONEYWELL INFORMATION SYSTEMS  
 LOC BILLERICA, MASS., U.S.A.

**CRT TERMINAL ASSY**

REV: D  
 DATE: 60131971  
 BY: [Signature]  
 APP: [Signature]

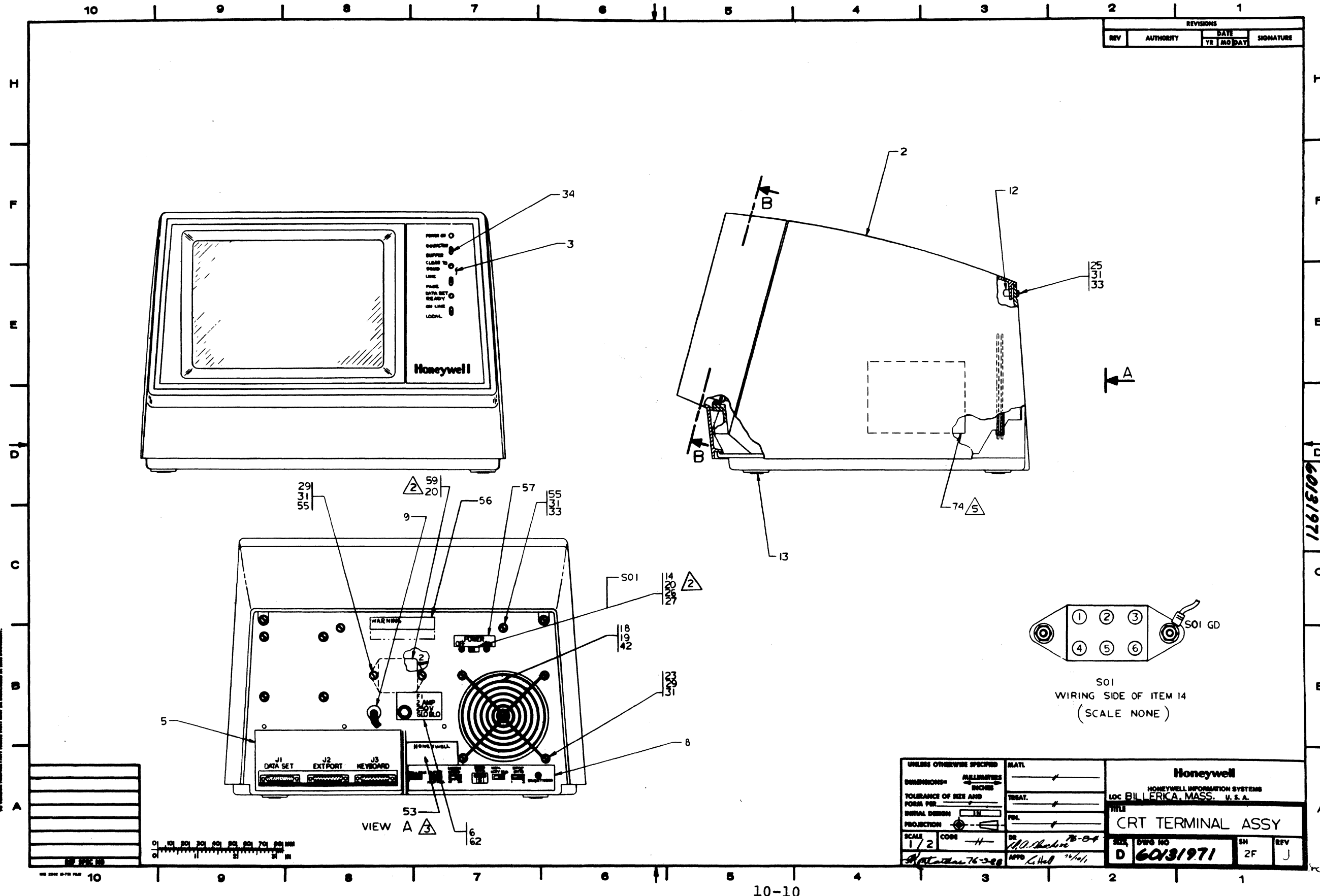

| REVISIONS |           |      |           |
|-----------|-----------|------|-----------|
| REV       | AUTHORITY | DATE | SIGNATURE |
|           |           |      |           |

126181971

|                                      |                        |  |                |
|--------------------------------------|------------------------|--|----------------|
| UNLESS OTHERWISE SPECIFIED           | MATL                   | <b>Honeywell</b><br>HONEYWELL INFORMATION SYSTEMS<br>LOC BILLERICA, MASS. U. S. A. |                |
| DIMENSIONS—<br>MILLIMETERS<br>INCHES | TREAT.                 |  |                |
| TOLERANCE OF SIZE AND<br>FORM PER    | FIN.                   | TITLE<br><b>CRT TERMINAL ASSY</b>  |                |
| INITIAL DESIGN                       | PROJ.                  | SCALE<br>1/2   | CODE<br>H      |
| PROJECTION                           | DR<br>A.D. Rubin 76-04 | REV<br>D   | DATE<br>7/1/71 |
|                                      |                        | SH<br>2F   | REV<br>J       |



HONEYWELL PROPRIETARY AND CONFIDENTIAL

Parts List for CRT Display Chassis Assembly

| INDEX NO. | DESCRIPTION | PART NUMBER | QTY. | ASSY. REV. | USE ON CODE | REF. FIG. |
|-----------|-------------|-------------|------|------------|-------------|-----------|
|-----------|-------------|-------------|------|------------|-------------|-----------|

|  |                                       |              |     |   |  |  |
|--|---------------------------------------|--------------|-----|---|--|--|
|  | CRT Display Chassis Assy,<br>Nonglare | 59733709-002 | Ref | B |  |  |
|--|---------------------------------------|--------------|-----|---|--|--|

NOTE

The following part numbers are those of Ball Brothers Research Corporation, Miratel Division, 1633 Terrace Drive, Roseville, Minnesota 55113.

|   |                                       |            |   |
|---|---------------------------------------|------------|---|
| 1 | CRT, 12-inch, Nonglare<br>(V1)        | 1-014-0747 | 1 |
| 2 | Deflection Coil Assy                  | 6-004-0321 | 1 |
| 3 | High Voltage Rectifier,<br>H510 (CR2) | 1-021-0424 | 1 |
| 4 | Vertical Choke (L1)                   | 6-003-0321 | 1 |
| 5 | High Voltage Transformer<br>(T2)      | 6-003-0325 | 1 |
| 6 | Circuit Board Assy, CRT               | 6-002-0530 | 1 |

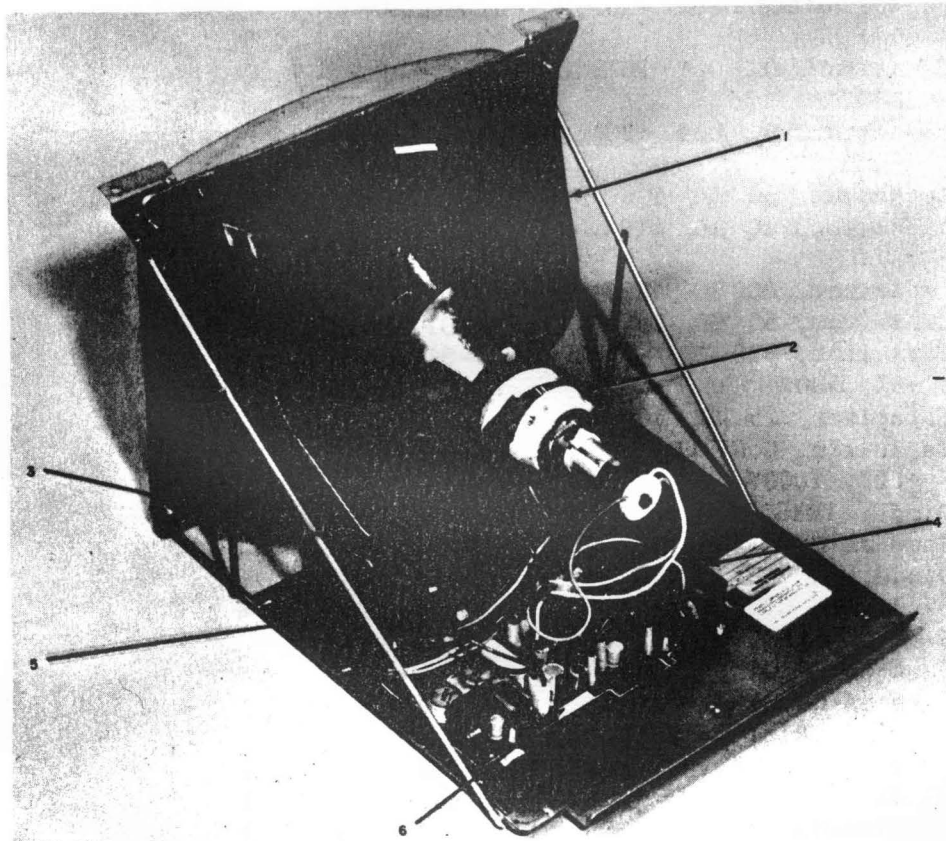

CRT Display Chassis Assembly

**HONEYWELL PROPRIETARY AND CONFIDENTIAL**

Parts List for CRT Circuit Board Assembly  
(Sheet 1 of 3)

| INDEX NO. | DESCRIPTION | PART NUMBER | QTY. | ASSY. REV. | USE ON CODE | REF. FIG. |
|-----------|-------------|-------------|------|------------|-------------|-----------|
|-----------|-------------|-------------|------|------------|-------------|-----------|

NOTE

The following part numbers are those of Ball Brothers Research Corporation, Miratel Division, 1633 Terrace Drive, Roseville, Minnesota 55113.

|       |   |            |   |  |  |     |
|-------|---|------------|---|--|--|-----|
|       | Circuit Board Assy, CRT                   | 6-002-0530 |   |  |  | Ref |
| C101  | Capacitor, 0.01 $\mu$ F, 1000V            | 1-012-0112 | 3 |  |  |     |
| C102  | Same as C101                              |            |   |  |  |     |
| C103  | Same as C101                              |            |   |  |  |     |
| C104  | Capacitor, 0.001 $\mu$ F $\pm$ 10%, 1000V | 1-012-0540 | 1 |  |  |     |
| C105  | Capacitor, 0.47 $\mu$ F $\pm$ 10%, 1000V  | 1-012-1005 | 2 |  |  |     |
| C106  | Same as C105                              |            |   |  |  |     |
| C107  | Capacitor 500 $\mu$ F, 6V                 | 1-012-2158 | 1 |  |  |     |
| C108  | Capacitor 100 $\mu$ F, 6V                 | 1-012-2160 | 1 |  |  |     |
| C109  | Capacitor 0.022 $\mu$ F $\pm$ 10%, 400V   | 1-012-0800 | 1 |  |  |     |
| C110  | Capacitor, 0.1 $\mu$ F $\pm$ 10%, 200V    | 1-012-0870 | 1 |  |  |     |
| C111  | Capacitor, 0.02 $\mu$ F $\pm$ 20%, 1000V  | 1-012-0780 | 1 |  |  |     |
| C112  | Capacitor, 50 $\mu$ F, 50V                | 1-012-2157 | 1 |  |  |     |
| C113  | Capacitor, 10 $\mu$ F, $\pm$ 10%, 63V     | 1-012-1130 | 1 |  |  |     |
| C114  | Capacitor, 200 $\mu$ F, 25V               | 1-012-2159 | 1 |  |  |     |
| C115  | Capacitor, 50 $\mu$ F, 25V                | 1-012-2165 | 1 |  |  |     |
| C118  | Capacitor, 820 PF $\pm$ 5%, 500V          | 1-012-0482 | 1 |  |  |     |
| C119  | Capacitor, 25 $\mu$ F, 50V                | 1-012-2193 | 1 |  |  |     |
| C120  | Capacitor, 0.01 $\mu$ F $\pm$ 20%, 1000V  | 1-012-0740 | 1 |  |  |     |
| CR101 | Diode, 1N3605                             | 1-021-0410 | 3 |  |  |     |
| CR102 | Same as CR101                             |            |   |  |  |     |
| CR103 | Diode, 1N4785                             | 1-021-0360 | 1 |  |  |     |
| CR104 | Diode, 1N3279                             | 1-021-0380 | 4 |  |  |     |
| CR105 | Same as CR104                             |            |   |  |  |     |
| CR106 | Same as CR104                             |            |   |  |  |     |
| CR107 | Same as CR104                             |            |   |  |  |     |
| CR108 | Same as CR101                             |            |   |  |  |     |
| F101  | Fuse, 2A, 125V                            | 1-028-0247 | 1 |  |  |     |
| L101  | Coil, Width                               | 1-016-0303 | 1 |  |  |     |
| Q101  | Transistor, 2N5830                        | 1-015-1172 | 1 |  |  |     |

**HONEYWELL PROPRIETARY AND CONFIDENTIAL**

Parts List for CRT Circuit Board Assembly  
(Sheet 2 of 3)

| INDEX NO. | DESCRIPTION                                     | PART NUMBER | QTY. | ASSY. REV. | USE ON CODE | REF. FIG. |
|-----------|---|-------------|------|------------|-------------|-----------|
| Q102      | Transistor, D13T1                               | 1-015-1157  | 1    |            |             |           |
| Q103      | Transistor, MPSA14                              | 1-015-1158  | 1    |            |             |           |
| Q104      | Transistor, MJE3055                             | 1-015-1156  | 1    |            |             |           |
| Q105      | Transistor, MPS-U05                             | 1-015-1159  | 1    |            |             |           |
| Q106      | Transistor, B1182                               | 1-015-1182  | 1    |            |             |           |
| Q107      | Transistor, 2N4124                              | 1-015-1139  | 1    |            |             |           |
| R101      | Resistor, 2.7K $\pm$ 5%,<br>1/2W                | 1-011-2280  | 2    |            |             |           |
| R103      | Resistor, 82K $\pm$ 5%, 1/2W                    | 1-011-2316  | 2    |            |             |           |
| R104      | Resistor, 100K $\pm$ 5%,<br>1/2W                | 1-011-2318  | 3    |            |             |           |
| R106      | Same as R104                                    |             |      |            |             |           |
| R107      | Resistor, Variable,<br>2.5M $\pm$ 20%, 1/8W     | 1-011-5566  | 1    |            |             |           |
| R108      | Resistor, 15 ohms $\pm$ 5%,<br>1/2W             | 1-011-2226  | 1    |            |             |           |
| R109      | Resistor, 47 ohms $\pm$ 5%,<br>1/2W             | 1-011-2238  | 2    |            |             |           |
| R110      | Resistor, 820 ohms $\pm$ 5%,<br>1/2W            | 1-011-2268  | 1    |            |             |           |
| R111      | Same as R109                                    |             |      |            |             |           |
| R112      | Resistor, 220 ohms $\pm$ 5%,<br>1/2W            | 1-011-2254  | 1    |            |             |           |
| R113      | Resistor, 470 ohms $\pm$ 5%,<br>1/2W            | 1-011-2262  | 2    |            |             |           |
| R114      | Resistor, 150 ohms $\pm$ 5%,<br>1/2W            | 1-011-2250  | 2    |            |             |           |
| R115      | Same as R103                                    |             |      |            |             |           |
| R116      | Resistor, Variable,<br>100K $\pm$ 20%, 1/3W     | 1-011-5435  | 1    |            |             |           |
| R117      | Resistor, 4.7K $\pm$ 5%,<br>1/2W                | 1-011-2286  | 2    |            |             |           |
| R118      | Resistor, 8.2K $\pm$ 5%,<br>1/2W                | 1-011-2292  | 1    |            |             |           |
| R119      | Same as R104                                    |             |      |            |             |           |
| R120      | Resistor, 560 ohms $\pm$ 5%,<br>1/2W            | 1-011-2264  | 1    |            |             |           |
| R121      | Resistor, Variable,<br>10K $\pm$ 20%, 1/8W      | 1-011-5312  | 1    |            |             |           |
| R122      | Same as R117                                    |             |      |            |             |           |
| R123      | Same as R114                                    |             |      |            |             |           |
| R124      | Resistor, Variable,<br>100 ohms $\pm$ 20%, 1/8W | 1-011-5095  | 1    |            |             |           |
| R125      | Resistor, WW, 3.3 ohms<br>$\pm$ 10%, 2W         | 1-011-1571  | 1    |            |             |           |
| R126      | Resistor, 390 ohms<br>$\pm$ 5%, 1/2W            | 1-011-2260  | 1    |            |             |           |

**HONEYWELL PROPRIETARY AND CONFIDENTIAL**

Parts List for CRT Circuit Board Assembly  
(Sheet 3 of 3)

| INDEX NO. | DESCRIPTION                                       | PART NUMBER | QTY. | ASSY. REV. | USE ON CODE | REF. FIG. |
|-----------|---|-------------|------|------------|-------------|-----------|
| R127      | Same as R113                                      |             |      |            |             |           |
| R128      | Same as R101                                      |             |      |            |             |           |
| R129      | Resistor, 5.6 ohms $\pm 5\%$ ,<br>1/2W            | 1-011-2218  | 1    |            |             |           |
| R130      | Resistor, WW, 1.2 ohms<br>$\pm 10\%$ , 2W         | 1-011-1395  | 1    |            |             |           |
| R131      | Resistor, 3.3K $\pm 5\%$ , 1/2W                   | 1-011-2282  | 1    |            |             |           |
| R132      | Resistor, WW, 8 $\bar{2}$ ohms<br>$\pm 10\%$ , 3W | 1-011-2375  | 1    |            |             |           |
| R133      | Resistor, 4.7K $\pm 5\%$ , 1/4W                   | 70-16-0472  | 1    |            |             |           |
| R135      | Resistor, 22K $\pm 5\%$ , 1/4W                    | 70-16-0223  | 2    |            |             |           |
| R136      | Same as R135                                      |             |      |            |             |           |
| R137      | Resistor, 33K $\pm 5\%$ , 1W                      | 1-011-2448  | 1    |            |             |           |
| VR101     | Diode, Zener, 1N758                               | 1-021-0180  | 1    |            |             |           |

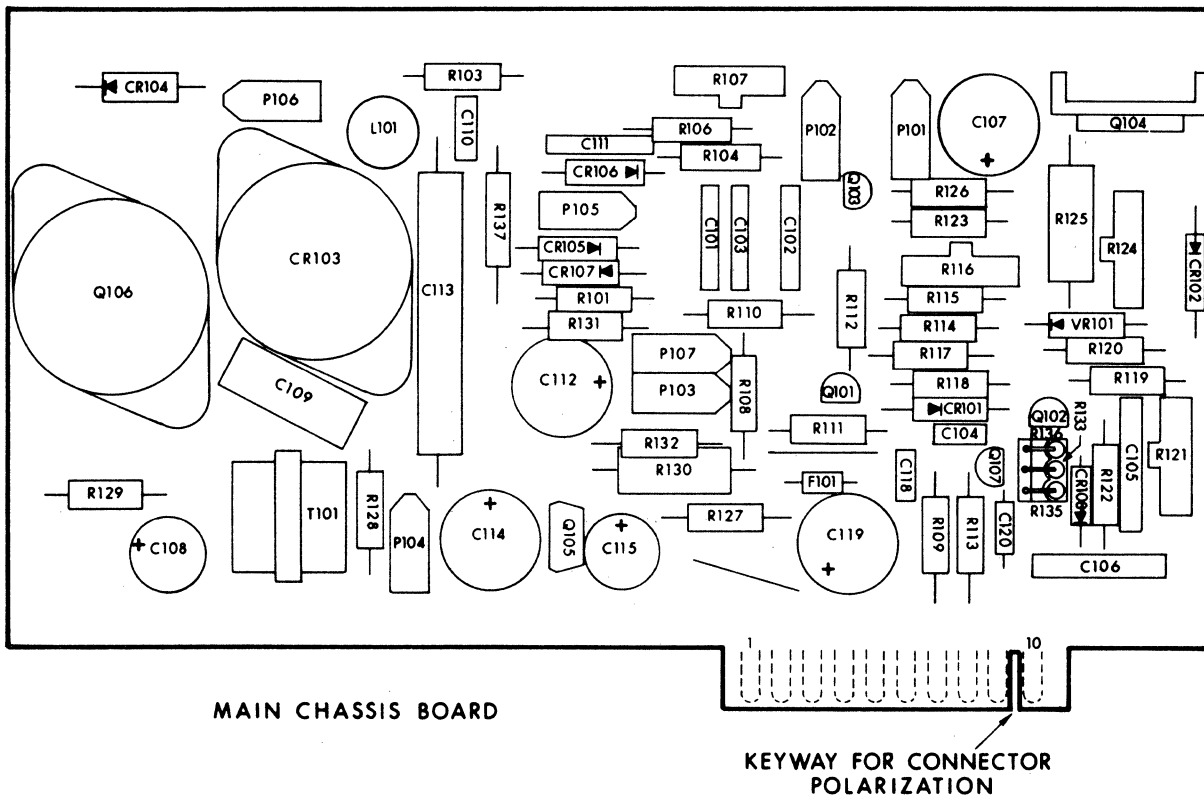

CRT Circuit Board Assembly

# HONEYWELL PROPRIETARY AND CONFIDENTIAL

THE INFORMATION CONTAINED IN THIS DOCUMENT IS PROPRIETARY TO HONEYWELL INFORMATION SYSTEMS INC. AND IS INTENDED FOR INTERNAL HONEYWELL USE ONLY. SUCH INFORMATION MAY BE DISTRIBUTED TO OTHERS ONLY BY WRITTEN PERMISSION OF AN AUTHORIZED HONEYWELL OFFICIAL. THIS RESTRICTION DOES NOT APPLY TO VENDORS OF SUBSTITUTE PARTS THAT MAY BE DISCLOSED IN THIS DOCUMENT.

|                                     |     |                    |     |                              | SIZE              | SHEET           | REV.     |       |      |     |
|-------------------------------------|-----|--------------------|-----|------------------------------|-------------------|-----------------|----------|-------|------|-----|
|                                     |     |                    |     |                              | 770322            | T               | 60130541 | 1/    | B    |     |
| * ITEM NO.                          | P C | IDENTIFICATION NO. | S C | DRAWING TITLE                | ASSEMBLY/QUANTITY |                 |          |       |      | U M |
|                                     |     |                    |     |                              | 001A              |                 |          |       |      |     |
| 1                                   | T   | 60130542=002       | A   | BP2TYC FABRICATED BD         | 1                 |                 |          |       |      | EA  |
| 2                                   | A   | 76952516=242       | V   | CONNECTOR ELEC 9 PIN         | 1                 |                 |          |       |      | EA  |
| 3                                   | A   | 04820294=208       | V   | CONNECTOR, MALE              | 1                 |                 |          |       |      | EA  |
| 4                                   | B   | 43167265=001       | V   | BRACKET                      | 3                 |                 |          |       |      | EA  |
| 5                                   | A   | 03010002=012       | V   | SCREW PH 6                   | 7                 |                 |          |       |      | EA  |
| 6                                   | P   | 03020045=003       | V   | WASHER FLAT 6                | 13                |                 |          |       |      | EA  |
| 7                                   | P   | 03030004=004       | V   | NUT LH 6                     | 13                |                 |          |       |      | EA  |
| 8                                   | A   | 03010002=010       | V   | SCREW PH 6                   | 6                 |                 |          |       |      | EA  |
| 9                                   | A   | 59701920=001       | =   | BUSHING VIP 7760             | 7                 |                 |          |       |      | EA  |
| 10                                  | P   | 02730001=001       | V   | COMPOUND SILICONE            | AR                |                 |          |       |      | OZ  |
| 11                                  | A   | 04490003=001       | V   | INSULATOR PLATE              | 3                 |                 |          |       |      | EA  |
| 12                                  | A   | 04490043=002       | V   | INSULATOR, SIL RUBBER        | 1                 |                 |          |       |      | EA  |
| 13                                  | A   | 04490045=001       | V   | HEAT SINK                    | 1                 |                 |          |       |      | EA  |
| 20                                  | A   | 43168115=001       | V   | INT CKT LM300                | 2                 |                 |          |       |      | EA  |
| 21                                  | A   | 04040758=003       | V   | INT CKT (L7812)              | 1                 |                 |          |       |      | EA  |
| 22                                  | A   | 04420018=001       | V   | DIODE 4721                   | 8                 |                 |          |       |      | EA  |
| <b>Honeywell</b>                    |     |                    |     | UM - UNIT OF MEASURE         |                   | TITLE           |          |       |      |     |
| HONEYWELL INFORMATION SYSTEMS       |     |                    |     | EA - EACH                    | IN - INCHES       | BP2TYC ASSEMBLY |          |       |      |     |
| LOC. BILLERICA, MASSACHUSETTS, USA. |     |                    |     | CM - CENTIMETER              | OZ - OUNCE        | SIZE            | P.L. NO. | SHEET | REV. |     |
|                                     |     |                    |     | G - GRAMS                    |                   | T               | 60130541 | 1/    | B    |     |
|                                     |     |                    |     | * ITEMS REVISED SINCE REV. A |                   |                 |          |       |      |     |

HS 851

DOES A DOCUMENT REVISION STATUS SHEET EXIST?

YES

S = SUBSTITUTE PARTS

THE INFORMATION CONTAINED IN THIS DOCUMENT IS PROPRIETARY TO HONEYWELL INFORMATION SYSTEMS INC. AND IS INTENDED FOR INTERNAL HONEYWELL USE ONLY. SUCH INFORMATION MAY BE DISTRIBUTED TO OTHERS ONLY BY WRITTEN PERMISSION OF AN AUTHORIZED HONEYWELL OFFICIAL. THIS RESTRICTION DOES NOT APPLY TO VENDORS OF SUBSTITUTE PARTS THAT MAY BE DISCLOSED IN THIS DOCUMENT.

|                                     |     |                    |     |                              | SIZE              | SHEET           | REV.     |       |      |     |
|-------------------------------------|-----|--------------------|-----|------------------------------|-------------------|-----------------|----------|-------|------|-----|
|                                     |     |                    |     |                              | 770322            | T               | 60130541 | 2     | B    |     |
| * ITEM NO.                          | P C | IDENTIFICATION NO. | S C | DRAWING TITLE                | ASSEMBLY/QUANTITY |                 |          |       |      | U M |
|                                     |     |                    |     |                              | 001A              |                 |          |       |      |     |
| 23                                  | P   | 04420003=001       | V   | DIODE 20H                    | 4                 |                 |          |       |      | EA  |
| 24                                  | A   | 04430010=001       | V   | ZENER DIODE 310 5.0V         | 1                 |                 |          |       |      | EA  |
| 25                                  | A   | 04450023=003       | V   | TSTR 2015=3(2N3055)          | 3                 |                 |          |       |      | EA  |
| 26                                  | A   | 04450016=001       | V   | TSTR 2N2904                  | INTCH             |                 |          |       |      | EA  |
| 26                                  | A   | 60067055=001       | P   | TSTR 2800 (2N2904)           | 2                 |                 |          |       |      | EA  |
| 28                                  | A   | 76952128=219       | V   | CAP 6.8UF 35V 10P            | 2                 |                 |          |       |      | EA  |
| 29                                  | A   | 76952128=426       | V   | CAP 33 UF 35V                | 1                 |                 |          |       |      | EA  |
| 30                                  | A   | 76952128=391       | V   | CAP 47UF 20V +10=10P         | 1                 |                 |          |       |      | EA  |
| 31                                  | A   | 76952128=109       | V   | CAP 1.0UF 10P 35V            | 3                 |                 |          |       |      | EA  |
| 32                                  | P   | 04350016=002       | =   | CAP 0.01UF 50V 20P           | 8                 |                 |          |       |      | EA  |
| 33                                  | A   | 43180064=048       | V   | CAP 7800 UF 20V              | 1                 |                 |          |       |      | EA  |
| 34                                  | A   | 43180064=065       | V   | CAP 2800 UF 50V              | 1                 |                 |          |       |      | EA  |
| 35                                  | A   | 43180064=082       | V   | CAP 470 UF 100V              | 1                 |                 |          |       |      | EA  |
| 37                                  | P   | 70928001=054       | V   | RES 9.1 OHM 1/4W             | 1                 |                 |          |       |      | EA  |
| 38                                  | A   | 70928100=021       | V   | RES 68 OHM 2P 1/4W           | 2                 |                 |          |       |      | EA  |
| 39                                  |     | 70928001=049       |     | RES 5.6 OHM 5P .25W          | 1                 |                 |          |       |      | EA  |
| <b>Honeywell</b>                    |     |                    |     | UM - UNIT OF MEASURE         |                   | TITLE           |          |       |      |     |
| HONEYWELL INFORMATION SYSTEMS       |     |                    |     | EA - EACH                    | IN - INCHES       | BP2TYC ASSEMBLY |          |       |      |     |
| LOC. BILLERICA, MASSACHUSETTS, USA. |     |                    |     | CM - CENTIMETER              | OZ - OUNCE        | SIZE            | P.L. NO. | SHEET | REV. |     |
|                                     |     |                    |     | G - GRAMS                    |                   | T               | 60130541 | 2     | B    |     |
|                                     |     |                    |     | * ITEMS REVISED SINCE REV. A |                   |                 |          |       |      |     |

HS 851

DOES A DOCUMENT REVISION STATUS SHEET EXIST?

YES

S = SUBSTITUTE PARTS



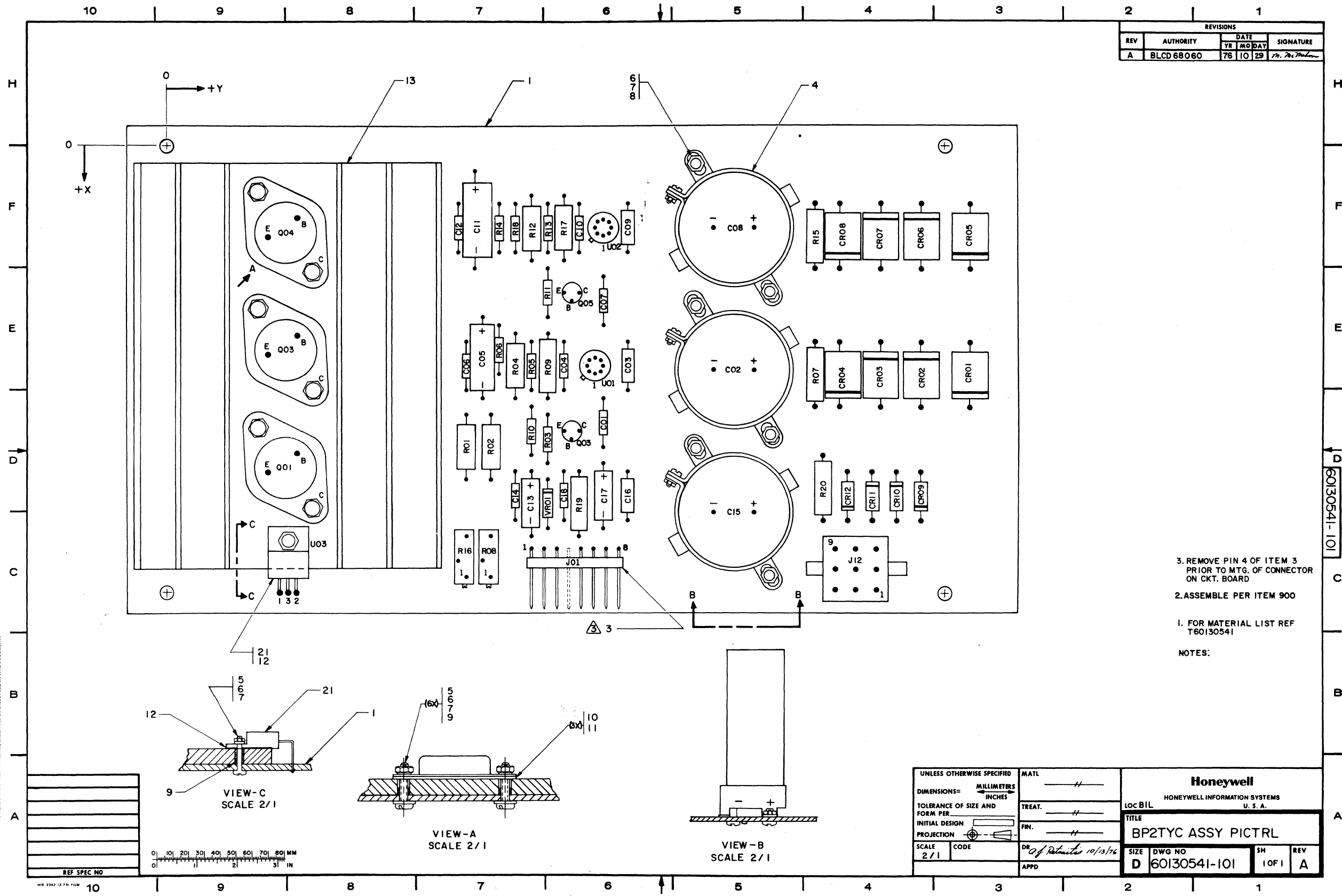

| REVISIONS |            |          |                    |
|-----------|------------|----------|--------------------|
| REV       | AUTHORITY  | DATE     | SIGNATURE          |
| A         | BLCD 68060 | 76 10 29 | <i>[Signature]</i> |

- NOTES:
- FOR MATERIAL LIST REF T60130541
  - ASSEMBLE PER ITEM 900
  - REMOVE PIN 4 OF ITEM 3 PRIOR TO MTG. OF CONNECTOR ON CKT. BOARD

THE INFORMATION CONTAINED IN THIS DOCUMENT IS PROPRIETARY TO HONEYWELL INFORMATION SYSTEMS AND IS INTENDED FOR INTERNAL HONEYWELL USE ONLY. NO DISSEMINATION OF AN UNAUTHORIZED HONEYWELL OFFICIAL. THIS RESTRICTION DOES NOT APPLY TO VENDOR PROPRIETARY PARTS THAT MAY BE DISCLOSED IN THIS DOCUMENT.

|   |      |                    |      |   |          |
|---|------|--------------------|------|---|----------|
| UNLESS OTHERWISE SPECIFIED                    |      | MATERIAL           |      | <b>Honeywell</b><br>HONEYWELL INFORMATION SYSTEMS<br>U. S. A. |          |
| DIMENSIONS = MILLIMETERS / INCHES             |      | TREAT.             |      |   |          |
| TOLERANCE OF SIZE AND FORM PER INITIAL DESIGN |      | FIN.               |      | LOC BIL<br>TITLE<br><b>BP2TYC ASSY PICTRL</b>                 |          |
| SCALE   | CODE | DR                 | APPD | SIZE  | REV      |
| 2/1   |      | <i>[Signature]</i> |      | D 60130541-101  | 1 OF 1 A |

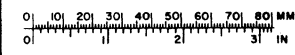

REF SPEC NO  
HIS 2342 (2-75) 111M

# HONEYWELL PROPRIETARY AND CONFIDENTIAL

THE INFORMATION CONTAINED IN THIS DOCUMENT IS PROPRIETARY TO HONEYWELL INFORMATION SYSTEMS INC. AND IS INTENDED FOR INTERNAL HONEYWELL USE ONLY. SUCH INFORMATION MAY BE DISTRIBUTED TO OTHERS ONLY BY WRITTEN PERMISSION OF AN AUTHORIZED HONEYWELL OFFICIAL. THIS RESTRICTION DOES NOT APPLY TO VENDORS OF SUPPLEMENTARY ITEMS THAT MAKE UP THE COMPLETE ASSEMBLY IN THIS DOCUMENT.

| ITEM NO. | P C | IDENTIFICATION NO. | S C | DRAWING TITLE           | ASSEMBLY/QUANTITY |      |  |  | U M |
|----------|-----|--------------------|-----|-------------------------|-------------------|------|--|--|-----|
|          |     |                    |     |                         | 001A              | 002B |  |  |     |
| 1        | T   | 60130703=001       | A   | BE2TS FABRICATED BD     | 1                 | 1    |  |  | EA  |
| 2        | A   | 04830331=001       | V   | CONN 25PO5 90DEg PWB    | 3                 | 3    |  |  | EA  |
| 3        | A   | 04820294=208       | V   | CONNECTOR, MALE         | 1                 | 1    |  |  | EA  |
| 4        | A   | 04820293=002       | V   | CONN, MALE, PWB, 5 PIN  | 1                 | 1    |  |  | EA  |
| 5        | A   | 04820293=003       | V   | CONN, MALE, PWB, 7 PIN  | 1                 | 1    |  |  | EA  |
| 6        | A   | 04820293=005       | V   | CONN, MALE, PWB, 15 PIN | 5                 | 5    |  |  | EA  |
| 7        | A   | 70934302=001       | V   | SWITCH SLIDE DPDT       | 5                 | 5    |  |  | EA  |
| 8        | A   | 04780085=001       | V   | SWITCH, THUMBWHEEL      | 1                 | 1    |  |  | EA  |
| 9        | A   | 04910055=003       | V   | LCUDSPEAKER PEMM MAG    | 1                 | 1    |  |  | EA  |
| 10       | TC  | 60129954=001       | A   | POT BRACKET             | 1                 | 1    |  |  | EA  |
| 11       | B   | 43168465=023       | V   | SWITCH CAP - BLACK      | 1                 | 1    |  |  | EA  |
| 12       | B   | 43168449=3210      | V   | RIVET, BLIND            | 2                 | 2    |  |  | EA  |
| 13       | P   | 03020001=011       | V   | WASHER FLAT 8           | 2                 | 2    |  |  | EA  |
| 14       | P   | 03020003=004       | V   | WASHER LOCK 8 STL       | 1                 | 1    |  |  | EA  |
| 15       | A   | 03050017=004       | V   | SPACER                  | 1                 | 1    |  |  | EA  |
| 16       | A   | 03010002=049       | V   | SCREW PH 8              | 1                 | 1    |  |  | EA  |

**Honeywell**

HONEYWELL INFORMATION SYSTEMS  
LOC. BILLERICA, MASSACHUSETTS, USA.

UM = UNIT OF MEASURE  
EA = EACH                      IN = INCHES  
CM = CENTIMETER            OZ = OUNCE  
G = GRAMS

TITLE  
**BE2TS2 ASSY**

| SIZE | P.L. NO. | SHEET | REV. |
|------|----------|-------|------|
| T    | 60130702 | 1/    | B    |

# ITEMS REVISED SINCE REV. A

#5 851  
DOES A DOCUMENT REVISION STATUS SHEET EXIST?  YES

3 = SUBSTITUTE PARTS

THE INFORMATION CONTAINED IN THIS DOCUMENT IS PROPRIETARY TO HONEYWELL INFORMATION SYSTEMS INC. AND IS INTENDED FOR INTERNAL HONEYWELL USE ONLY. SUCH INFORMATION MAY BE DISTRIBUTED TO OTHERS ONLY BY WRITTEN PERMISSION OF AN AUTHORIZED HONEYWELL OFFICIAL. THIS RESTRICTION DOES NOT APPLY TO VENDORS OF SUPPLEMENTARY ITEMS THAT MAKE UP THE COMPLETE ASSEMBLY IN THIS DOCUMENT.

| ITEM NO. | P C | IDENTIFICATION NO. | S C | DRAWING TITLE           | ASSEMBLY/QUANTITY |      |  |  | U M |
|----------|-----|--------------------|-----|-------------------------|-------------------|------|--|--|-----|
|          |     |                    |     |                         | 001A              | 002B |  |  |     |
| 17       | A   | 04040130=001       | V   | INT CKT (74LS00)        | 28                | 28   |  |  | EA  |
| 18       | A   | 04040139=001       | V   | INT CKT (74LS03)        | 3                 | 3    |  |  | EA  |
| 19       | A   | 04040136=001       | V   | INT CKT (74LS04)        | 19                | 19   |  |  | EA  |
| 20       | A   | 04040166=001       | V   | INT CKT (74LS05)        | 1                 | 1    |  |  | EA  |
| 21       | A   | 04040140=001       | V   | INT CKT (74LS08)        | 10                | 10   |  |  | EA  |
| 22       | A   | 04040131=001       | V   | INT CKT (74LS10)        | 8                 | 9    |  |  | EA  |
| 23       | A   | 04040132=001       | V   | INT CKT (74LS11)        | 5                 | 5    |  |  | EA  |
| 24       | A   | 04040272=001       | V   | IC, FLIP FLOP (74LS109) | 13                | 13   |  |  | EA  |
| 25       | A   | 04040133=001       | V   | INT CKT (74LS20)        | 4                 | 4    |  |  | EA  |
| 26       | A   | 04040141=001       | V   | INT CKT (74LS21)        | 2                 | 2    |  |  | EA  |
| 27       | A   | 04040441=001       | V   | INT CKT (74LS85)        | 6                 | 6    |  |  | EA  |
| 28       | A   | 04040135=001       | V   | INT CKT (74LS86)        | 1                 | 1    |  |  | EA  |
| 29       | A   | 04040436=001       | V   | INT CKT (74LS157)       | 5                 | 5    |  |  | EA  |
| 30       | A   | 04040257=001       | V   | INT CKT (74LS161)       | 10                | 10   |  |  | EA  |
| 31       | A   | 04040273=001       | V   | INT CKT 74LS174         | 6                 | 6    |  |  | EA  |
| 32       | A   | 04040250=001       | V   | INT CKT (74LS175)       | 1                 | 1    |  |  | EA  |

**Honeywell**

HONEYWELL INFORMATION SYSTEMS  
LOC. BILLERICA, MASSACHUSETTS, USA.

UM = UNIT OF MEASURE  
EA = EACH                      IN = INCHES  
CM = CENTIMETER            OZ = OUNCE  
G = GRAMS

TITLE  
**BE2TS2 ASSY**

| SIZE | P.L. NO. | SHEET | REV. |
|------|----------|-------|------|
| T    | 60130702 | 2     | B    |

# ITEMS REVISED SINCE REV. A

#5 851  
DOES A DOCUMENT REVISION STATUS SHEET EXIST?  YES

3 = SUBSTITUTE PARTS



# HONEYWELL PROPRIETARY AND CONFIDENTIAL

THE INFORMATION CONTAINED IN THIS DOCUMENT IS PROPRIETARY TO HONEYWELL INFORMATION SYSTEMS INC. AND IS INTENDED FOR INTERNAL HONEYWELL USE ONLY. SUCH INFORMATION MAY BE DISTRIBUTED TO OTHERS ONLY BY WRITTEN PERMISSION OF AN AUTHORIZED HONEYWELL OFFICIAL. THIS RESTRICTION DOES NOT APPLY TO VENDORS OF PROPRIETARY ITEMS TO HONEYWELL IN THIS DOCUMENT.

|            |     |                    |     |                     | SIZE              |       |          | SHEET | REV. |     |
|------------|-----|--------------------|-----|---------------------|-------------------|-------|----------|-------|------|-----|
|            |     |                    |     |                     | 770322            | T     | 60130702 | 3     | B    |     |
| * ITEM NO. | P C | IDENTIFICATION NO. | S C | DRAWING TITLE       | ASSEMBLY/QUANTITY |       |          |       |      | U M |
|            |     |                    |     |                     | 001A              | 002B  |          |       |      |     |
| 33         | A   | 04040152-001       | V   | 74LS253 IC          | 8                 | 8     |          |       |      | EA  |
| 34         | A   | 04040157-001       | V   | INT CKT 74LS257     | 2                 | 2     |          |       |      | EA  |
| 35         | A   | 04040251-001       | V   | INT CKT (74LS193)   | 5                 | 5     |          |       |      | EA  |
| 36         | A   | 04040457-001       | V   | IC, FULL ADDER, TTL | 2                 | 2     |          |       |      | EA  |
| 37         | A   | 04040163-001       | V   | INT CKT (749140)    | 1                 | -     |          |       |      | EA  |
| * 38       | A   | 76952432-001       | V   | INT CKT (74503)     | 1                 | 2     |          |       |      | EA  |
| 39         | A   | 60067019-001       | V   | INT CKT (74154)     | 1                 | 1     |          |       |      | EA  |
| 40         | A   | 04040259-001       | V   | INT CKT (74166)     | 1                 | 1     |          |       |      | EA  |
| 41         | A   | 04040755-001       | V   | 5307A IC            | 1                 | 1     |          |       |      | EA  |
| 42         | A   | 04040858-001       | V   | INT CKT 9208        | INTCH             | INTCH |          |       |      | EA  |
| 42         | A   | 04040861-001       | V   | INT CKT 2708        | 1                 | 1     |          |       |      | EA  |
| 43         | A   | 78200039-001       | V   | INT CKT (9602)      | 1                 | 1     |          |       |      | EA  |
| 44         | A   | 04040856-002       | V   | INT CKT (2102)      | 16                | 16    |          |       |      | EA  |
| 45         | A   | 76952709-002       | V   | INT CKT 1602        | 1                 | 1     |          |       |      | EA  |
| 46         | A   | 60067093-001       | V   | INT CKT (LM1488)    | 2                 | 2     |          |       |      | EA  |
| 47         | A   | 60067074-002       | V   | IC LM1489A          | 2                 | 2     |          |       |      | EA  |

**Honeywell**  
HONEYWELL INFORMATION SYSTEMS  
LOC. BILLERICA, MASSACHUSETTS, USA.

UM - UNIT OF MEASURE  
EA - EACH      IN - INCHES  
CM - CENTIMETER      OZ - OUNCE  
G - GRAMS

TITLE  
**BE2TS2 ASSY**

| SIZE | P.L. NO. | SHEET | REV. |
|------|----------|-------|------|
| T    | 60130702 | 3     | B    |

NS 831  
DOES A DOCUMENT REVISION STATUS SHEET EXIST?  YES      3 = SUBSTITUTE PARTS

THE INFORMATION CONTAINED IN THIS DOCUMENT IS PROPRIETARY TO HONEYWELL INFORMATION SYSTEMS INC. AND IS INTENDED FOR INTERNAL HONEYWELL USE ONLY. SUCH INFORMATION MAY BE DISTRIBUTED TO OTHERS ONLY BY WRITTEN PERMISSION OF AN AUTHORIZED HONEYWELL OFFICIAL. THIS RESTRICTION DOES NOT APPLY TO VENDORS OF PROPRIETARY ITEMS TO HONEYWELL IN THIS DOCUMENT.

|            |     |                    |     |                      | SIZE              |      |          | SHEET | REV. |     |
|------------|-----|--------------------|-----|----------------------|-------------------|------|----------|-------|------|-----|
|            |     |                    |     |                      | 770322            | T    | 60130702 | 4     | B    |     |
| * ITEM NO. | P C | IDENTIFICATION NO. | S C | DRAWING TITLE        | ASSEMBLY/QUANTITY |      |          |       |      | U M |
|            |     |                    |     |                      | 001A              | 002B |          |       |      |     |
| 48         | A   | 70950400-001       | V   | PHOTO TRANSISTOR     | 2                 | 2    |          |       |      | EA  |
| 49         | A   | 76951996-002       | V   | INT CKT (LM311)      | 1                 | 1    |          |       |      | EA  |
| 50         | P   | 74201257-003       | V   | SWITCH8              | 3                 | 3    |          |       |      | EA  |
| 51         | A   | 70950553-010       | V   | RES NETWORK HD160    | 3                 | 3    |          |       |      | EA  |
| 52         | A   | 04020524-003       | V   | 330 OHM RES NETWORK  | 2                 | 2    |          |       |      | EA  |
| 53         | B   | 43168781-006       | V   | RES 100K VAR 1W      | 1                 | 1    |          |       |      | EA  |
| 54         | A   | 70928100-073       | V   | RES 10K OHM 2P 1/4W  | 1                 | 1    |          |       |      | EA  |
| * 55       | A   | 70928100-029       | V   | RES 150 OHM 2P 1/4W  | 1                 | 2    |          |       |      | EA  |
| 56         | A   | 70928100-049       | V   | RES 1.0K OHM 2P 1/4W | 33                | 33   |          |       |      | EA  |
| 57         | A   | 70928100-080       | V   | RES 20K OHM 2P 1/4W  | 5                 | 5    |          |       |      | EA  |
| 58         | A   | 70928100-082       | V   | RES 24K OHM 2P 1/4W  | 2                 | 2    |          |       |      | EA  |
| 59         | A   | 70928100-035       | V   | RES 270 OHM 2P 1/4W  | 2                 | 2    |          |       |      | EA  |
| 60         | A   | 70928100-058       | V   | RES 2.4K OHM 2P 1/4W | 1                 | 1    |          |       |      | EA  |
| 61         | A   | 70928100-056       | V   | RES 2.0K OHM 2P 1/4W | 2                 | 3    |          |       |      | EA  |
| * 62       | A   | 70928100-037       | V   | RES 330 OHM 2P 1/4W  | 3                 | 4    |          |       |      | EA  |
| 63         | A   | 70928100-086       | V   | RES 36K OHM 2P 1/4W  | 2                 | 2    |          |       |      | EA  |

**Honeywell**  
HONEYWELL INFORMATION SYSTEMS  
LOC. BILLERICA, MASSACHUSETTS, USA.

UM - UNIT OF MEASURE  
EA - EACH      IN - INCHES  
CM - CENTIMETER      OZ - OUNCE  
G - GRAMS

TITLE  
**BE2TS2 ASSY**

| SIZE | P.L. NO. | SHEET | REV. |
|------|----------|-------|------|
| T    | 60130702 | 4     | B    |

NS 831  
DOES A DOCUMENT REVISION STATUS SHEET EXIST?  YES      3 = SUBSTITUTE PARTS

**HONEYWELL PROPRIETARY AND CONFIDENTIAL**

THE INFORMATION CONTAINED IN THIS DOCUMENT IS PROPRIETARY TO HONEYWELL INFORMATION SYSTEMS INC. AND IS INTENDED FOR INTERNAL HONEYWELL USE ONLY. SUCH INFORMATION MAY BE DISTRIBUTED TO OTHERS ONLY BY WRITTEN PERMISSION OF AN AUTHORIZED HONEYWELL OFFICIAL. THIS RESTRICTION DOES NOT APPLY TO VENDORS OF PROPRIETARY PLANS, TO THE PUBLIC OR TO THE GENERAL TRADE.

| ITEM NO. | P C | IDENTIFICATION NO. | S C | DRAWING TITLE        | ASSEMBLY/QUANTITY |      |  |  | U M |
|----------|-----|--------------------|-----|----------------------|-------------------|------|--|--|-----|
|          |     |                    |     |                      | 001A              | 002B |  |  |     |
| 64       | A   | 70928100=062       | V   | RES 3.6K OHM 2P 1/4W | 1                 | 1    |  |  | EA  |
| 65       | A   | 70928100=060       | V   | RES 3.0K OHM 2P 1/4W | 6                 | 6    |  |  | EA  |
| 66       | A   | 70928100=088       | V   | RES 43K OHM 2P 1/4W  | 2                 | 2    |  |  | EA  |
| 67       | A   | 70928100=041       | V   | RES 470 OHM 2P 1/4W  | 1                 | 1    |  |  | EA  |
| 68       | A   | 70928100=089       | V   | RES 47K OHM 2P 1/4W  | 1                 | 1    |  |  | EA  |
| 69       | A   | 70928503=006       | V   | RES 500 OHM VAR 1W   | 1                 | 1    |  |  | EA  |
| 70       | A   | 70928101=027       | V   | RES 51 OHM 2P 1/2W   | 1                 | 1    |  |  | EA  |
| 71       | A   | 70928100=018       | V   | RES 51 OHM 2P 1/4W   | 1                 | 1    |  |  | EA  |
| 72       | A   | 70928100=043       | V   | RES 560 OHM 2P 1/4W  | 1                 | 1    |  |  | EA  |
| 73       | A   | 70928100=038       | V   | RES 360 OHM 2P 1/4W  | 1                 | 1    |  |  | EA  |
| 74       | A   | 70928100=095       | V   | RES 82K OHM 2P 1/4W  | 1                 | 1    |  |  | EA  |
| 75       | A   | 04350024=001       | V   | CAP.056UF 50V+80=20P | 50                | 50   |  |  | EA  |
| 76       | A   | 76952128=254       | V   | 47UF 10V CAPACITOR   | 1                 | 1    |  |  | EA  |
| 77       | A   | 76952128=151       | =   | CAP 4.7 UF 10P 10V   | 1                 | 1    |  |  | --  |
| 78       | A   | 04360001=030       | V   | CAP 100 PF 100V 5P   | 2                 | 2    |  |  | EA  |
| 79       | A   | 76951965=111       | V   | CAP. 4.7NF           | 2                 | 2    |  |  | --  |

**Honeywell**  
HONEYWELL INFORMATION SYSTEMS  
LOC. BILLERICA, MASSACHUSETTS, USA.

UM = UNIT OF MEASURE  
EA - EACH                      IN - INCHES  
CM - CENTIMETER            OZ - OUNCE  
G - GRAMS

TITLE  
**BE2T52 ASSY**

|      |          |       |      |
|------|----------|-------|------|
| SIZE | P.L. NO. | SHEET | REV. |
| T    | 60130702 | 5     | B    |

# ITEMS REVISED SINCE REV. A

MS 851  
DOES A DOCUMENT REVISION STATUS SHEET EXIST?  YES

3 = SUBSTITUTE PARTS

THE INFORMATION CONTAINED IN THIS DOCUMENT IS PROPRIETARY TO HONEYWELL INFORMATION SYSTEMS INC. AND IS INTENDED FOR INTERNAL HONEYWELL USE ONLY. SUCH INFORMATION MAY BE DISTRIBUTED TO OTHERS ONLY BY WRITTEN PERMISSION OF AN AUTHORIZED HONEYWELL OFFICIAL. THIS RESTRICTION DOES NOT APPLY TO VENDORS OF PROPRIETARY PLANS, TO THE PUBLIC OR TO THE GENERAL TRADE.

| ITEM NO. | P C | IDENTIFICATION NO. | S C | DRAWING TITLE        | ASSEMBLY/QUANTITY |      |  |  | U M |
|----------|-----|--------------------|-----|----------------------|-------------------|------|--|--|-----|
|          |     |                    |     |                      | 001A              | 002B |  |  |     |
| 80       | A   | 04350016=001       | V   | CAP 0.001UF 50V 20P  | 1                 | 1    |  |  | EA  |
| 81       | A   | 04350016=003       | V   | CAP .01UF 10P 50V    | 1                 | 1    |  |  | EA  |
| 82       | A   | 76951963=102       | V   | CAP .022UF 50V       | 2                 | 2    |  |  | EA  |
| 83       | A   | 76951963=209       | V   | CAP .47UF 50V        | 3                 | 3    |  |  | EA  |
| 84       | A   | 60067073=001       | V   | DIODE 125=1          | 3                 | 3    |  |  | EA  |
| 85       | A   | 43175973=004       | V   | TSTR 2N2222A         | 1                 | 1    |  |  | EA  |
| 86       | B   | 43140883=001       | =   | TSTR 2N2369          | 2                 | 2    |  |  | EA  |
| 87       | =   | 43142298=004       | V   | TSTR 2N2907          | 2                 | 2    |  |  | EA  |
| 88       | P   | 04470010=009       | V   | CRYSTAL (11.142 MHZ) | 1                 | 1    |  |  | EA  |
| 89       | P   | 03030004=001       | V   | NLT LW 4             | 6                 | 6    |  |  | EA  |
| 90       | =   | 03020002=021       | V   | WASHER FLAT NYLON    | 12                | 12   |  |  | EA  |
| 91       | A   | 03010016=001       | V   | SCREW                | 6                 | 6    |  |  | EA  |
| 92       | B   | 43138943=002       | V   | SCREW LOCK ASSY      | 6                 | 6    |  |  | EA  |
| 93       | P   | 04120007=008       | V   | WIRE, ELECTRICAL     | AR                | AR   |  |  | IN  |
| 94       | A   | 04910090=003       | D   | SCCKET 16            | 2                 | 2    |  |  | EA  |
| 95       | A   | 04120112=005       | V   | 30AWG MAGNET WIRE    | AR                | AR   |  |  | IN  |

**Honeywell**  
HONEYWELL INFORMATION SYSTEMS  
LOC. BILLERICA, MASSACHUSETTS, USA.

UM = UNIT OF MEASURE  
EA - EACH                      IN - INCHES  
CM - CENTIMETER            OZ - OUNCE  
G - GRAMS

TITLE  
**BE2T52 ASSY**

|      |          |       |      |
|------|----------|-------|------|
| SIZE | P.L. NO. | SHEET | REV. |
| T    | 60130702 | 6     | B    |

# ITEMS REVISED SINCE REV. A

MS 851  
DOES A DOCUMENT REVISION STATUS SHEET EXIST?  YES

3 = SUBSTITUTE PARTS



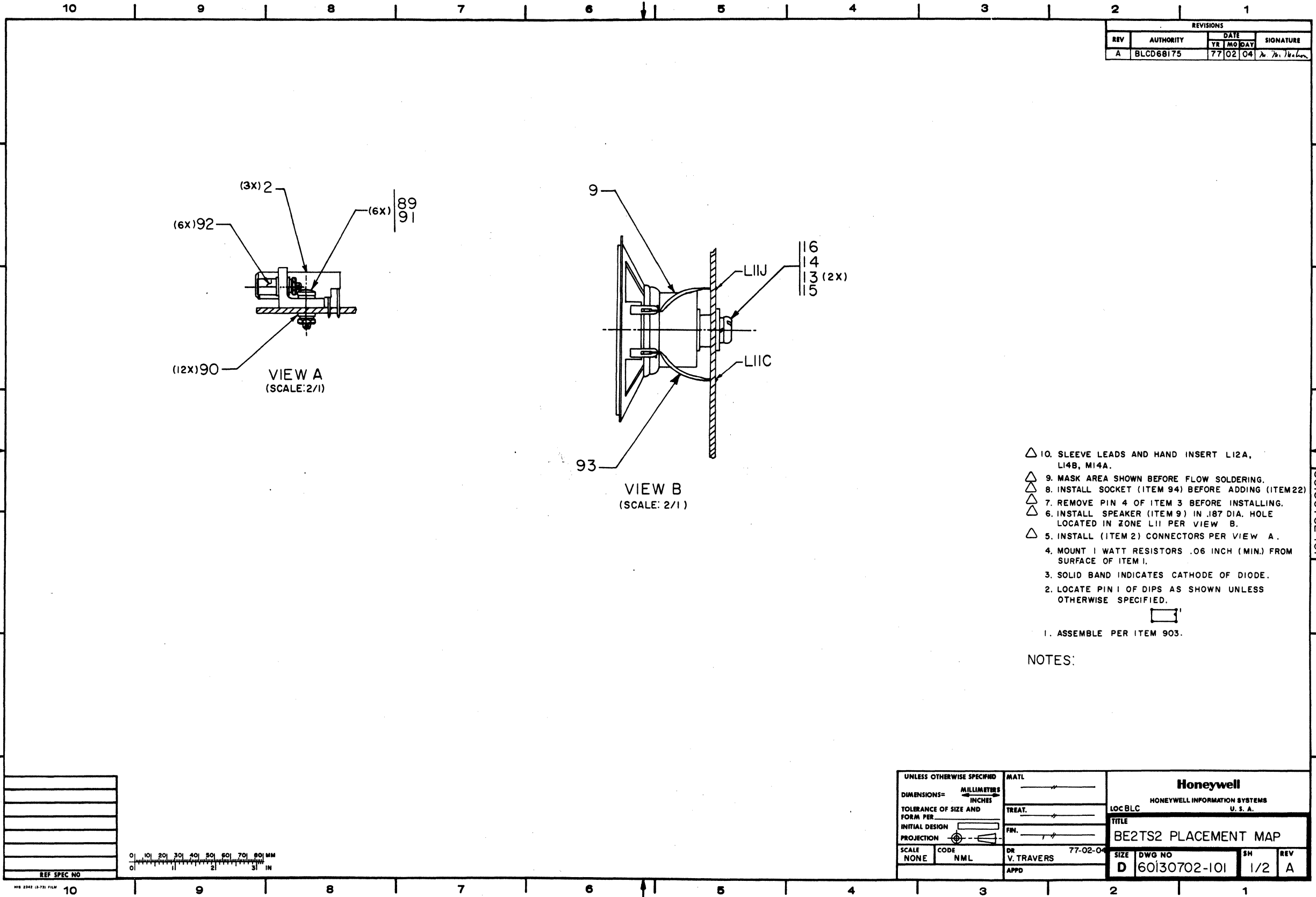

THE INFORMATION CONTAINED IN THIS DOCUMENT IS PROPRIETARY TO HONEYWELL INFORMATION SYSTEMS AND IS INTENDED FOR INTERNAL HONEYWELL USE ONLY. SUCH INFORMATION MAY BE DISTRIBUTED TO OTHERS ONLY BY WRITTEN PERMISSION OF AN AUTHORIZED HONEYWELL OFFICIAL. THIS RESTRICTION DOES NOT APPLY TO VENDOR PROPRIETARY PARTS THAT MAY BE DISCLOSED IN THIS DOCUMENT.

- △ 10. SLEEVE LEADS AND HAND INSERT L12A, L14B, M14A.  
 △ 9. MASK AREA SHOWN BEFORE FLOW SOLDERING.  
 △ 8. INSTALL SOCKET (ITEM 94) BEFORE ADDING (ITEM 22)  
 △ 7. REMOVE PIN 4 OF ITEM 3 BEFORE INSTALLING.  
 △ 6. INSTALL SPEAKER (ITEM 9) IN .187 DIA. HOLE LOCATED IN ZONE LII PER VIEW B.  
 △ 5. INSTALL (ITEM 2) CONNECTORS PER VIEW A.  
 4. MOUNT 1 WATT RESISTORS .06 INCH (MIN.) FROM SURFACE OF ITEM 1.  
 3. SOLID BAND INDICATES CATHODE OF DIODE.  
 2. LOCATE PIN 1 OF DIPS AS SHOWN UNLESS OTHERWISE SPECIFIED.  
 1. ASSEMBLE PER ITEM 903.

NOTES:

|   |          |                        |                     |   |       |
|---|----------|------------------------|---------------------|---|-------|
| UNLESS OTHERWISE SPECIFIED                    |          | MATL                   |                     | <b>Honeywell</b><br>HONEYWELL INFORMATION SYSTEMS<br>U. S. A. |       |
| DIMENSIONS = MILLIMETERS                      |          | TREAT.                 |                     |   |       |
| TOLERANCE OF SIZE AND FORM PER INITIAL DESIGN |          | FIN.                   |                     | LOC BLC   |       |
| PROJECTION                                    |          | DR V. TRAVERS 77-02-04 |                     | TITLE   |       |
| SCALE NONE                                    | CODE NML | APPD                   |                     | BE2TS2 PLACEMENT MAP  |       |
| REF SPEC NO                                   |          | SIZE D                 | DWG NO 60130702-101 | SH 1/2  | REV A |

60130702-101

| REVISIONS |           |           |           |
|-----------|-----------|-----------|-----------|
| REV       | AUTHORITY | DATE      | SIGNATURE |
|           |           | YE MO DAY |           |
|           |           |           |           |

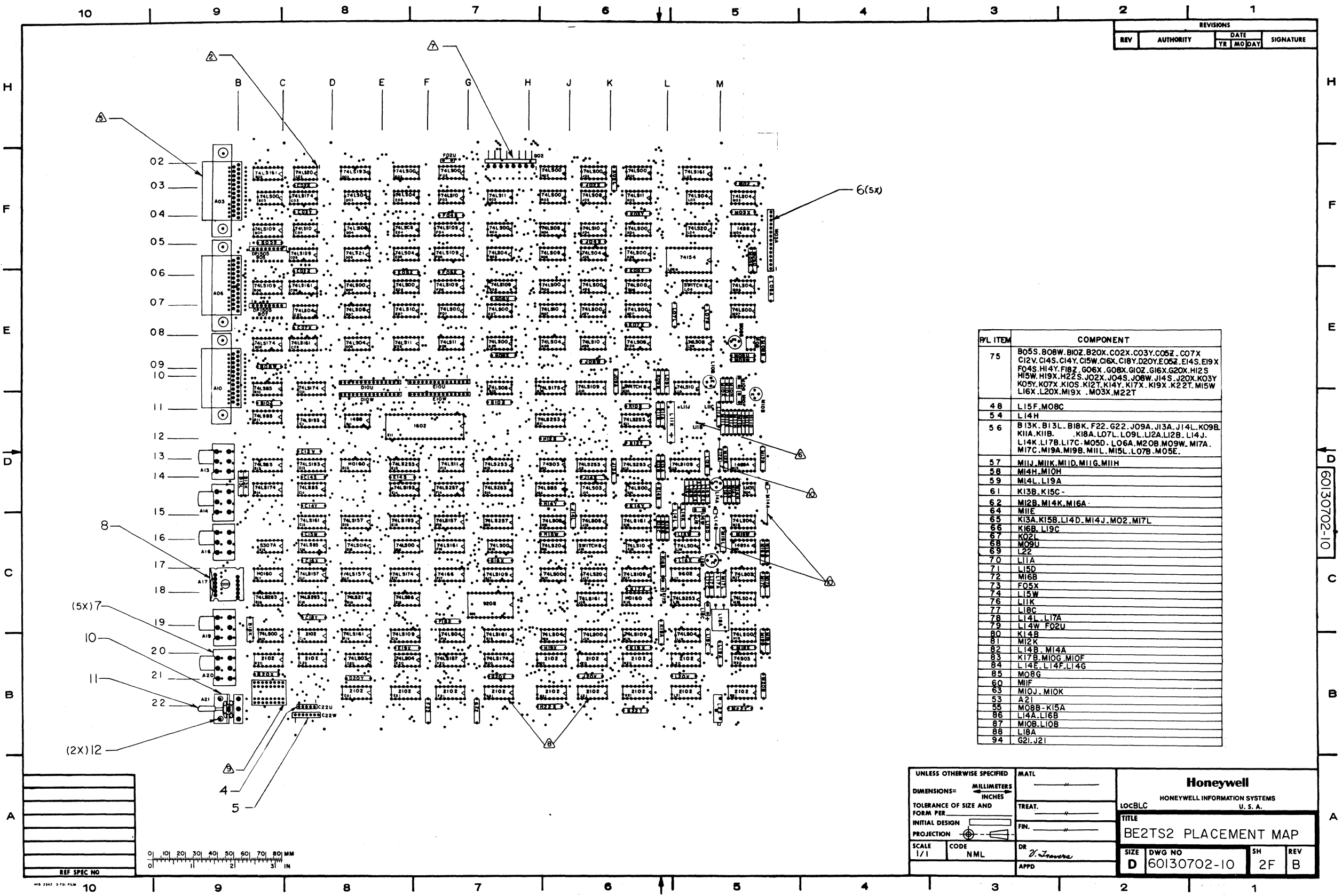

THE INFORMATION CONTAINED IN THIS DOCUMENT IS PROPRIETARY TO HONEYWELL INFORMATION SYSTEMS AND IS INTENDED FOR INTERNAL HONEYWELL USE ONLY. NO INFORMATION FROM THIS DOCUMENT IS TO BE RELEASED TO THE PUBLIC OR TO ANY OTHER HONEYWELL EMPLOYEE WITHOUT THE EXPRESS WRITTEN PERMISSION OF AN AUTHORIZED HONEYWELL OFFICIAL. THIS RESTRICTION DOES NOT APPLY TO OTHER PROPRIETARY PARTS THAT MAY BE DESCRIBED IN THIS DOCUMENT.

60130702-10

# HONEYWELL PROPRIETARY AND CONFIDENTIAL

THE INFORMATION CONTAINED IN THIS DOCUMENT IS PROPRIETARY TO HONEYWELL INFORMATION SYSTEMS INC. AND IS INTENDED FOR INTERNAL HONEYWELL USE ONLY. SUCH INFORMATION MAY BE DISTRIBUTED TO OTHERS ONLY BY WRITTEN PERMISSION OF AN AUTHORIZED HONEYWELL OFFICIAL. THIS RESTRICTION DOES NOT APPLY TO VENDORS OF MATERIALS TO BE USED IN THIS DOCUMENT.

|          |     |                    |               | SIZE          |                         |          |      | SHEET | REV |     |    |
|----------|-----|--------------------|---------------|---------------|-------------------------|----------|------|-------|-----|-----|----|
|          |     |                    |               | 770924        | T                       | 60130730 |      |       | 1/7 | C   |    |
| ITEM NO. | P C | IDENTIFICATION NO. | S C           | DRAWING TITLE | ASSEMBLY QUANTITY       |          |      |       |     | U M |    |
|          |     |                    |               |               | 001A                    | 002B     | 002C |       |     |     |    |
| *        | 1   | T                  | 60130732-001  | A             | RE2TCY FABRICATED BD    | 1        | 1    | 1     |     |     | EA |
| *        | 2   | NA                 | 04830331-001  | V             | CONN 25POS 90DEG PWB    | 3        | 3    | 3     |     |     | EA |
| *        | 3   | NA                 | 04820294-208  | V             | CONNECTOR, MALE         | 1        | 1    | 1     |     |     | EA |
| *        | 4   | NA                 | 04820293-002  | V             | CONN, MALE, PWB, 5 PIN  | 1        | 1    | 1     |     |     | EA |
| *        | 5   | NA                 | 04820293-003  | V             | CONN, MALE, PWB, 7 PIN  | 1        | 1    | 1     |     |     | EA |
| *        | 6   | NA                 | 04820293-005  | V             | CONN, MALE, PWB, 15 PIN | 1        | 1    | 1     |     |     | EA |
| *        | 7   | NA                 | 70934302-001  | -             | SWITCH SLIDE            | 5        | 5    | 5     |     |     | EA |
| *        | 8   | NA                 | 04780085-001  | V             | SWITCH-THUMBWHEEL       | 1        | 1    | 1     |     |     | EA |
| *        | 9   | NA                 | 04910055-003  | V             | LOUDSPEAKER             | 1        | 1    | 1     |     |     | EA |
| *        | 10  | TC                 | 60129954-001  | A             | POT BRACKET             | 1        | 1    | 1     |     |     | EA |
| *        | 11  | B                  | 43168465-023  | V             | SWITCH CAP - BLACK      | 1        | 1    | 1     |     |     | EA |
| *        | 12  | B                  | 43168449-3210 | V             | RIVET, BLIND            |          | 2    | 2     | 2   |     | EA |
| *        | 13  | P                  | 03020001-050  | V             | WASHER FLAT B           |          | 1    | 1     | 1   |     | EA |
| *        | 14  | P                  | 03020003-004  | V             | WASHER LOCK B STL       |          | 1    | 1     | 1   |     | EA |
| *        | 15  | P                  | 03020002-003  | V             | WASHER FLAT NYLON       |          | 2    | 2     | 2   |     | EA |
| *        | 16  | A                  | 03010002-016  | V             | SCREW PH B              |          | 1    | 1     | 1   |     | EA |

**Honeywell**  
HONEYWELL INFORMATION SYSTEMS  
LOC. BILLERICA, MASSACHUSETTS, USA.

UM - UNIT OF MEASURE  
EA - EACH      IN - INCHES  
CM - CENTIMETER      OZ - OUNCE  
G - GRAMS

TITLE  
**BE2TCY ASSY**

|      |          |       |      |
|------|----------|-------|------|
| SIZE | P.L. NO. | SHEET | REV. |
| T    | 60130730 | 1/7   | C    |

\* ITEMS REVISED SINCE REV. B

MS 951  
DOES A DOCUMENT REVISION STATUS SHEET EXIST?

YES

S = SUBSTITUTE PARTS

THE INFORMATION CONTAINED IN THIS DOCUMENT IS PROPRIETARY TO HONEYWELL INFORMATION SYSTEMS INC. AND IS INTENDED FOR INTERNAL HONEYWELL USE ONLY. SUCH INFORMATION MAY BE DISTRIBUTED TO OTHERS ONLY BY WRITTEN PERMISSION OF AN AUTHORIZED HONEYWELL OFFICIAL. THIS RESTRICTION DOES NOT APPLY TO VENDORS OF MATERIALS TO BE USED IN THIS DOCUMENT.

|          |     |                    |              | SIZE          |                   |          |      | SHEET | REV |     |    |
|----------|-----|--------------------|--------------|---------------|-------------------|----------|------|-------|-----|-----|----|
|          |     |                    |              | 770924        | T                 | 60130730 |      |       | 2   | C   |    |
| ITEM NO. | P C | IDENTIFICATION NO. | S C          | DRAWING TITLE | ASSEMBLY QUANTITY |          |      |       |     | U M |    |
|          |     |                    |              |               | 001A              | 002B     | 002C |       |     |     |    |
| *        | 17  | A                  | 04040130-001 | V             | IC (74LS00)       | 28       | 28   | 28    |     |     | EA |
| *        | 18  | A                  | 04040139-001 | V             | IC (74LS03)       | 3        | 3    | 3     |     |     | EA |
| *        | 19  | A                  | 04040136-001 | V             | IC (74LS04)       | 19       | 19   | 19    |     |     | EA |
| *        | 20  | A                  | 04040166-001 | V             | IC (74LS05)       | 1        | 1    | 1     |     |     | EA |
| *        | 21  | A                  | 04040140-001 | V             | IC (74LS08)       | 10       | 11   | 11    |     |     | EA |
| *        | 22  | A                  | 04040131-001 | V             | IC (74LS10)       | 10       | 10   | 10    |     |     | EA |
| *        | 23  | A                  | 04040132-001 | V             | IC (74LS11)       | 5        | 5    | 5     |     |     | EA |
| *        | 24  | A                  | 04040272-001 | V             | IC (74LS109)      | 13       | 13   | 13    |     |     | EA |
| *        | 25  | A                  | 04040133-001 | V             | IC (74LS20)       | 4        | 4    | 4     |     |     | EA |
| *        | 26  | A                  | 04040141-001 | V             | IC (74LS21)       | 2        | 2    | 2     |     |     | EA |
| *        | 27  | A                  | 04040441-001 | V             | IC (74LS85)       | 6        | 6    | 6     |     |     | EA |
| *        | 28  | A                  | 04040135-001 | V             | IC (74LS86)       | 1        | 1    | 1     |     |     | EA |
| *        | 29  | A                  | 04040436-001 | V             | IC (74LS157)      | 5        | 5    | 5     |     |     | EA |
| *        | 30  | A                  | 04040257-001 | V             | IC (74LS161)      | 10       | 10   | 10    |     |     | EA |
| *        | 31  | A                  | 04040273-001 | V             | IC (74LS174)      | 6        | 6    | 6     |     |     | EA |
| *        | 32  | A                  | 04040250-001 | V             | IC (74LS175)      | 1        | 1    | 1     |     |     | EA |

**Honeywell**  
HONEYWELL INFORMATION SYSTEMS  
LOC. BILLERICA, MASSACHUSETTS, USA.

UM - UNIT OF MEASURE  
EA - EACH      IN - INCHES  
CM - CENTIMETER      OZ - OUNCE  
G - GRAMS

TITLE  
**BE2TCY ASSY**

|      |          |       |      |
|------|----------|-------|------|
| SIZE | P.L. NO. | SHEET | REV. |
| T    | 60130730 | 2     | C    |

\* ITEMS REVISED SINCE REV. B

MS 951  
DOES A DOCUMENT REVISION STATUS SHEET EXIST?

YES

S = SUBSTITUTE PARTS

**HONEYWELL PROPRIETARY AND CONFIDENTIAL**

THE INFORMATION CONTAINED IN THIS DOCUMENT IS PROPRIETARY TO HONEYWELL INFORMATION SYSTEMS INC. AND IS INTENDED FOR INTERNAL HONEYWELL USE ONLY. SUCH INFORMATION MAY BE DISTRIBUTED TO OTHERS ONLY BY WRITTEN PERMISSION OF AN AUTHORIZED HONEYWELL OFFICIAL. THIS RESTRICTION DOES NOT APPLY TO VENDORS PROPRIETARY PARTS THAT MAY BE DISCLOSED IN THIS DOCUMENT.

| ITEM NO. | P C | IDENTIFICATION NO. | S C | DRAWING TITLE       | ASSEMBLY/QUANTITY |      |       | U M |
|----------|-----|--------------------|-----|---------------------|-------------------|------|-------|-----|
|          |     |                    |     |                     | 001A              | 002B | 002C  |     |
| * 33     | A   | 04040152-001       | V   | IC (74LS253)        | 8                 | 8    | 8     | EA  |
| * 34     | A   | 04040157-001       | V   | IC (74LS257)        | 2                 | 2    | 2     | EA  |
| * 35     | A   | 04040251-001       | V   | IC (74LS193)        | 5                 | 5    | 5     | EA  |
| * 36     | A   | 04040457-001       | V   | IC (74LS283)        | 2                 | 2    | 2     | EA  |
| * 37     | A   | 76952432-001       | V   | IC (74503)          | 1                 | 1    | 1     | EA  |
| * 38     | A   | 60067019-001       | V   | IC (74154)          | 1                 | 1    | 1     | EA  |
| * 39     | A   | 04040259-001       | V   | IC (74166)          | 1                 | 1    | 1     | EA  |
| * 40     | A   | 04040755-001       | V   | IC (5307A)          | 1                 | 1    | 1     | EA  |
| * 42     | A   | 04040858-201       | V   | IC (9208) ROM       | 1                 | 1    | 1     | EA  |
| * 42     | A   | 04040861-001       | V   | IC (2708) ROM       | -                 | -    | INTCH | EA  |
| * 43     | A   | 78200039-001       | V   | IC (9602)           | 1                 | 1    | 1     | EA  |
| * 44     | A   | 04040856-002       | V   | IC (2102A-2)        | 16                | 16   | 16    | EA  |
| * 45     | A   | 76952709-002       | V   | IC (1602)           | 1                 | 1    | 1     | EA  |
| * 46     | A   | 60067093-001       | V   | IC (1488)           | 2                 | 2    | 2     | EA  |
| * 47     | A   | 60067074-002       | V   | IC (1489A)          | 2                 | 2    | 2     | EA  |
| * 48     | A   | 70950400-001       | V   | IC (202-PCP) 2.0 MA | 2                 | 2    | 2     | EA  |

|  |   |                           |                      |                      |            |
|--|---|---------------------------|----------------------|----------------------|------------|
| <b>Honeywell</b><br>HONEYWELL INFORMATION SYSTEMS<br>LOC. BILLERICA, MASSACHUSETTS, USA. | LM - UNIT OF MEASURE<br>EA - EACH<br>CM - CENTIMETER<br>G - GRAMS | IN - INCHES<br>OZ - OUNCE | TITLE<br>BE2TCY ASSY |                      |            |
|  | * ITEMS REVISED SINCE REV. B                                      |                           | SIZE<br>T            | P.L. NO.<br>60130730 | SHEET<br>3 |

MS 894  
 DOES A DOCUMENT REVISION STATUS SHEET EXIST?  YES

S = SUBSTITUTE PARTS

THE INFORMATION CONTAINED IN THIS DOCUMENT IS PROPRIETARY TO HONEYWELL INFORMATION SYSTEMS INC. AND IS INTENDED FOR INTERNAL HONEYWELL USE ONLY. SUCH INFORMATION MAY BE DISTRIBUTED TO OTHERS ONLY BY WRITTEN PERMISSION OF AN AUTHORIZED HONEYWELL OFFICIAL. THIS RESTRICTION DOES NOT APPLY TO VENDORS PROPRIETARY PARTS THAT MAY BE DISCLOSED IN THIS DOCUMENT.

| ITEM NO. | P C | IDENTIFICATION NO. | S C | DRAWING TITLE        | ASSEMBLY/QUANTITY |      |      | U M |
|----------|-----|--------------------|-----|----------------------|-------------------|------|------|-----|
|          |     |                    |     |                      | 001A              | 002B | 002C |     |
| * 49     | A   | 76951996-002       | V   | IC (LM311N)          | 1                 | 1    | 1    | EA  |
| * 50     | A   | 74202440-005       | V   | SWITCH 8             | 3                 | 3    | 3    | EA  |
| * 51     | NA  | 70950553-010       | V   | RES NETWORK H0160    | 3                 | 3    | 3    | EA  |
| * 52     | NA  | 04020524-003       | V   | 330 OHM RES NETWORK  | 2                 | 2    | 2    | EA  |
| * 53     | NA  | 43168781-006       | V   | RES 100K VAR 1W      | 1                 | 1    | 1    | EA  |
| * 54     | RA  | 70928100-073       | V   | RES 10K OHM 2P 1/4W  | 1                 | 1    | 1    | EA  |
| * 55     | RA  | 70928100-029       | V   | RES 150 OHM 2P 1/4W  | 2                 | 2    | 2    | EA  |
| * 56     | RA  | 70928100-049       | V   | RES 1.0K OHM 2P 1/4W | 32                | 31   | 31   | EA  |
| * 57     | RA  | 70928100-080       | V   | RES 20K OHM 2P 1/4W  | 5                 | 6    | 6    | EA  |
| * 58     | NA  | 70928100-082       | V   | RES 24K OHM 2P 1/4W  | 2                 | 2    | 2    | EA  |
| * 59     | RA  | 70928100-035       | V   | RES 270 OHM 2P 1/4W  | 2                 | 2    | 2    | EA  |
| * 60     | NA  | 70928100-058       | V   | RES 2.4KOHM 2P1/4WEA | 1                 | 1    | 1    | EA  |
| * 61     | RA  | 70928100-056       | V   | RES 2.0K OHM 2P 1/4W | 3                 | 3    | 3    | EA  |
| * 62     | RA  | 70928100-037       | V   | RES 330 OHM 2P 1/4W  | 4                 | 4    | 4    | EA  |
| * 63     | NA  | 70928100-086       | V   | RES 36K OHM 2P 1/4W  | 2                 | 2    | 2    | EA  |
| * 64     | NA  | 70928100-062       | V   | RES 3.6K OHM 2P 1/4W | 1                 | 1    | 1    | EA  |

|  |   |                           |                      |                      |            |
|--|---|---------------------------|----------------------|----------------------|------------|
| <b>Honeywell</b><br>HONEYWELL INFORMATION SYSTEMS<br>LOC. BILLERICA, MASSACHUSETTS, USA. | LM - UNIT OF MEASURE<br>EA - EACH<br>CM - CENTIMETER<br>G - GRAMS | IN - INCHES<br>OZ - OUNCE | TITLE<br>BE2TCY ASSY |                      |            |
|  | * ITEMS REVISED SINCE REV. B                                      |                           | SIZE<br>T            | P.L. NO.<br>60130730 | SHEET<br>4 |

MS 894  
 DOES A DOCUMENT REVISION STATUS SHEET EXIST?  YES

S = SUBSTITUTE PARTS

HONEYWELL PROPRIETARY AND CONFIDENTIAL

THE INFORMATION CONTAINED IN THIS DOCUMENT IS PROPRIETARY TO HONEYWELL INFORMATION SYSTEMS INC. AND IS INTENDED FOR INTERNAL HONEYWELL USE ONLY. SUCH INFORMATION MAY BE DISTRIBUTED TO OTHERS ONLY BY WRITTEN PERMISSION OF AN AUTHORIZED HONEYWELL OFFICIAL. THIS RESTRICTION DOES NOT APPLY TO VENDORS OF ANY PARTS TO BE USED ON THIS DOCUMENT.

| ITEM NO. | P.C. | IDENTIFICATION NO. | S.C. | DRAWING TITLE        | ASSEMBLY QUANTITY |      |      | U.M. |
|----------|------|--------------------|------|----------------------|-------------------|------|------|------|
|          |      |                    |      |                      | 001A              | 002B | 002C |      |
| * 65     | NA   | 70928100-060       | V    | RES 3.0K OHM 2P 1/4W | 6                 | 6    | 6    | EA   |
| * 66     | NA   | 70928100-088       | V    | RES 43K OHM 2P 1/4W  | 2                 | 2    | 2    | EA   |
| * 67     | NA   | 70928100-041       | V    | RES 470 OHM 2P 1/4W  | 1                 | 1    | 1    | EA   |
| * 68     | NA   | 70928100-089       | V    | RES 47K OHM 2P 1/4W  | 1                 | 1    | 1    | EA   |
| * 69     | NA   | 70928503-006       | -    | RES VAR WM RECTILIN  | 1                 | 1    | 1    | EA   |
| * 70     | RA   | 70928101-027       | V    | RES 51 OHM 2P 1/2W   | 1                 | 1    | 1    | EA   |
| * 71     | RA   | 70928100-018       | V    | RES 51 OHM 2P 1/4W   | 1                 | 1    | 1    | EA   |
| * 72     | NA   | 70928100-043       | V    | RES 560 OHM 2P 1/4W  | 1                 | 1    | 1    | EA   |
| * 73     | NA   | 70928100-038       | V    | RES 360 OHM 2P 1/4W  | 1                 | 1    | 1    | EA   |
| * 74     | RA   | 70928100-095       | V    | RES 82K OHM 2P 1/4W  | 1                 | 1    | 1    | EA   |
| * 75     | NA   | 04350024-001       | V    | CAP.056UF 50V+80-20P | 50                | 50   | 50   | EA   |
| * 76     | RA   | 76952128-254       | V    | 47UF 10V CAPACITOR   | 1                 | 1    | 1    | EA   |
| * 77     | RA   | 76952128-151       | P    | CAP 4.7 UF 10% 10V   | 1                 | 1    | 1    | EA   |
| * 78     | A    | 04360001-030       | V    | CAP 100 PF 100V 5P   | 2                 | 2    | 2    | EA   |
| * 79     | RA   | 76951965-111       | V    | CAP. 4.7NF           | 2                 | 2    | 2    | --   |
| * 80     | NA   | 04350016-001       | V    | CAP 0.001UF 50V 20P  | 1                 | 1    | 1    | EA   |

|  |   |                           |                      |                      |            |
|--|---|---------------------------|----------------------|----------------------|------------|
| <b>Honeywell</b><br>HONEYWELL INFORMATION SYSTEMS<br>LOC. BILLERICA, MASSACHUSETTS, USA. | UM - UNIT OF MEASURE<br>EA - EACH<br>CM - CENTIMETER<br>G - GRAMS | IN - INCHES<br>OZ - OUNCE | TITLE<br>BE2TCY ASSY |                      |            |
|  | * ITEMS REVISED SINCE REV. B                                      |                           | SIZE<br>T            | P.L. NO.<br>60130730 | SHEET<br>5 |

IS 99  
DOES A DOCUMENT REVISION STATUS SHEET EXIST?  YES

S = SUBSTITUTE PARTS

THE INFORMATION CONTAINED IN THIS DOCUMENT IS PROPRIETARY TO HONEYWELL INFORMATION SYSTEMS INC. AND IS INTENDED FOR INTERNAL HONEYWELL USE ONLY. SUCH INFORMATION MAY BE DISTRIBUTED TO OTHERS ONLY BY WRITTEN PERMISSION OF AN AUTHORIZED HONEYWELL OFFICIAL. THIS RESTRICTION DOES NOT APPLY TO VENDORS OF ANY PARTS TO BE USED ON THIS DOCUMENT.

| ITEM NO. | P.C. | IDENTIFICATION NO. | S.C. | DRAWING TITLE        | ASSEMBLY QUANTITY |       |       | U.M. |
|----------|------|--------------------|------|----------------------|-------------------|-------|-------|------|
|          |      |                    |      |                      | 001A              | 002B  | 002C  |      |
| * 81     | RA   | 76952149-117       | V    | CAP 0.01UF 100V 5P   | 1                 | 1     | 1     | EA   |
| * 82     | A    | 76951963-102       | P    | CAP 50V .022UF 201   | 2                 | 2     | 2     | EA   |
| * 83     | A    | 76951963-209       | P    | CAP 50V .47 UF 201   | 3                 | 3     | 3     | EA   |
| * 84     | NA   | 60067073-001       | V    | DIODE 125-1          | 3                 | 3     | 3     | EA   |
| * 85     | NA   | 43175973-004       | V    | TRANSISTOR           | 1                 | 1     | 1     | EA   |
| * 86     | NA   | 43140883-001       | P    | TRANSISTOR           | 2                 | 2     | 2     | EA   |
| * 87     | NA   | 43142298-004       | V    | TSTR 2N2907          | 2                 | 2     | 2     | EA   |
| * 88     | NA   | 04470010-009       | V    | CRYSTAL (11.142 MHZ) | 1                 | 1     | 1     | EA   |
| * 89     | P    | 03030004-001       | V    | NUT LW 4             | 6                 | 6     | 6     | EA   |
| * 90     | P    | 03020002-001       | V    | WASHER FLAT NYLON    | 6                 | 6     | 6     | EA   |
| * 91     | A    | 03010016-001       | V    | SCREW                | 6                 | 6     | 6     | EA   |
| * 92     | B    | 43138943-002       | V    | SCREW LOCK ASSY      | INTCH             | INTCH | INTCH | EA   |
| * 92     | -    | 04890109-001       | V    | RETAINER ELEC CONN   | 6                 | 6     | 6     | EA   |
| * 93     | -    | 70906180-001       | V    | STRAP RETAINING      | 1                 | 1     | 1     | EA   |
| * 94     | NA   | 04430074-002       | -    | DIODE SI 3472        | 1                 | 1     | 1     | EA   |
| * 95     | NA   | 70928102-010       | V    | RES 24 OHM 2% 1W     | 1                 | 1     | 1     | EA   |

|  |   |                           |                      |                      |            |
|--|---|---------------------------|----------------------|----------------------|------------|
| <b>Honeywell</b><br>HONEYWELL INFORMATION SYSTEMS<br>LOC. BILLERICA, MASSACHUSETTS, USA. | UM - UNIT OF MEASURE<br>EA - EACH<br>CM - CENTIMETER<br>G - GRAMS | IN - INCHES<br>OZ - OUNCE | TITLE<br>BE2TCY ASSY |                      |            |
|  | * ITEMS REVISED SINCE REV. B                                      |                           | SIZE<br>T            | P.L. NO.<br>60130730 | SHEET<br>6 |

IS 99  
DOES A DOCUMENT REVISION STATUS SHEET EXIST?  YES

S = SUBSTITUTE PARTS



**HONEYWELL PROPRIETARY AND CONFIDENTIAL**

THE INFORMATION CONTAINED IN THIS DOCUMENT IS PROPRIETARY TO HONEYWELL INFORMATION SYSTEMS INC. AND IS INTENDED FOR INTERNAL HONEYWELL USE ONLY. SUCH INFORMATION MAY BE DISTRIBUTED TO OTHERS ONLY BY WRITTEN PERMISSION OF AN AUTHORIZED HONEYWELL OFFICIAL. THIS RESTRICTION DOES NOT APPLY TO VENDORS PROPRIETARY INFORMATION THAT MAY BE DEVELOPED IN THIS DOCUMENT.

| ITEM NO. | P C | IDENTIFICATION NO. | S C | DRAWING TITLE        | ASSEMBLY/QUANTITY |      |      | U M |
|----------|-----|--------------------|-----|----------------------|-------------------|------|------|-----|
|          |     |                    |     |                      | 001A              | 002B | 002C |     |
| * 96     | A   | 59701646-002       |     | SOCKET-24PIN-LOW-PRO | 1                 | 1    | 1    | EA  |
| * 97     | P   | 04120007-008       | V   | WIRE,ELECTRICAL      | AR                | AR   | AR   | IN  |
| * 98     | P   | 03020001-004       | V   | WASHER FLAT 4        | 6                 | 6    | 6    | EA  |
| * 99     | RA  | 70928100-066       | V   | RES 5.1K OHM 2P 1/4W | -                 | 1    | 1    | EA  |
| 900      | D   | 60130730-101       | D   | BE2TCY PLACEMENT MAP | X                 | -    | -    | --  |
| * 900    | D   | 60130730-102       | D   | BE2TCY PLACEMENT MAP | -                 | X    | X    | --  |
| * 901    | A   | 60130730-301       | D   | BE2TCY STATUS SHEET  | X                 | X    | X    | --  |
| * 902    | D   | 60130734-001       | D   | BE2TCY LBD           | X                 | X    | X    | --  |
| * 903    | A   | 14040011-000       | M   | PLB COMP ASSEM SPEC  | X                 | X    | X    | --  |
| 904      | R   | 60130733-001       | D   | BE2TCY FILESET       | X                 | -    | -    | --  |
| * 904    | R   | 60130733-002       | D   | BE2TCY FILESET       | -                 | X    | X    | --  |
| * 905    | T   | 60130730-501       | D   | BE2TCY DIFF DOC W/E  | -                 | X    | X    | --  |
| 906      | A   | 60130730-801       | D   | BE2TCY DIFF DOC P/A  | -                 | X    | -    | --  |
| * 906    | A   | 60130730-802       | D   | BE2TCY DIFF DOC P/A  | -                 | -    | X    | --  |

|  |  |  |                      |                      |             |
|--|--|--|----------------------|----------------------|-------------|
| <b>Honeywell</b><br>HONEYWELL INFORMATION SYSTEMS<br>LOC. BILLERICA, MASSACHUSETTS, USA. | UM - UNIT OF MEASURE<br>EA - EACH                      IN - INCHES<br>CM - CENTIMETER            OZ - OUNCE<br>G - GRAMS |  | TITLE<br>BE2TCY ASSY |                      |             |
|  | * ITEMS REVISED SINCE REV. B   |  | SIZE<br>T            | P.L. NO.<br>60130730 | SHEET<br>7F |

10 924  
DOES A DOCUMENT REVISION STATUS SHEET EXIST?  YES

S = SUBSTITUTE PARTS

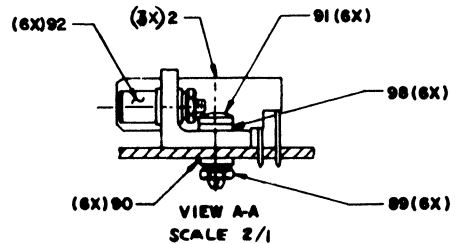
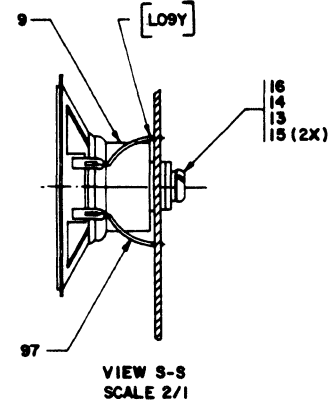
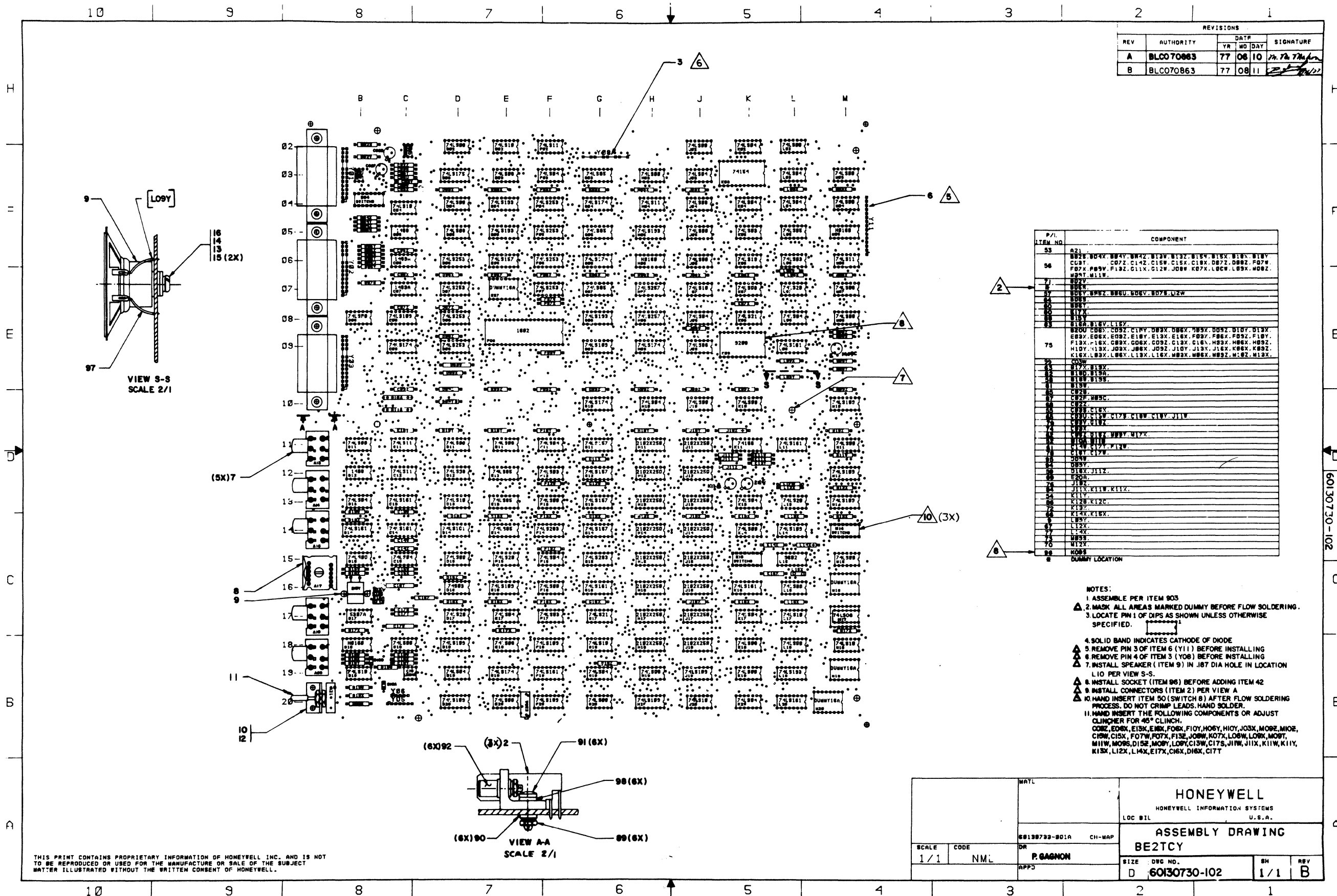

| REVISIONS |           |    |    |     |                    |
|-----------|-----------|----|----|-----|--------------------|
| REV       | AUTHORITY | YR | MO | DAY | SIGNATURE          |
| A         | BLC070863 | 77 | 06 | 10  | <i>[Signature]</i> |
| B         | BLC070863 | 77 | 08 | 11  | <i>[Signature]</i> |

| P/L | ITEM NO  | COMPONENT |
|-----|--|-----------|
| 53  | A21  |           |
| 54  | B02S, B04X, B04Y, B04Z, B12W, B13Z, B13Y, B15X, B16X, B17Y |           |
| 55  | C03T, C07Z, C14Z, C15W, C15X, C19X, D07Z, D08Z, F07W       |           |
| 56  | F07X, F09V, F10Z, G11X, G12W, J08W, K07X, L06W, L09X, M08Z |           |
| 57  | M09Y, M11W   |           |
| 58  | B03V   |           |
| 59  | B05V, B06Z, B06U, G06V, B07S, L12W                         |           |
| 60  | B08S   |           |
| 61  | B09Y   |           |
| 62  | B10X   |           |
| 63  | B11Y   |           |
| 64  | B12Z, B15V, L15Y   |           |
| 65  | B16W, C05Z, C05Y, C10V, D09X, D09Z, M05Y, D05Z, D10Y, G13X |           |
| 66  | E03X, E06X, E08Z, E10Y, E13X, E16X, F03Y, F06X, F08Z, F10Y |           |
| 67  | F13X, F16X, G03X, G06X, G09Z, G13X, G16X, H03X, H06Z, H09Z |           |
| 68  | H10Y, I13X, J03X, J06X, J09Z, J10Y, J13X, J16X, K06X, K09Z |           |
| 69  | K16X, L03X, L06X, L13X, L16X, M03X, M06X, M09Z, M12Z, M13X |           |
| 70  | M09W   |           |
| 71  | B17X, B18X   |           |
| 72  | B19Z, B19S   |           |
| 73  | B19W, B19S   |           |
| 74  | B19V   |           |
| 75  | C08Z, C10X   |           |
| 76  | C09Z, C10X, C17X, C17W, C18Y, J17V                         |           |
| 77  | C09Y, J17Z   |           |
| 78  | C10Y, J17Z   |           |
| 79  | C11Y, J17Z, B09Y, B10Y                                     |           |
| 80  | M10W, M11W   |           |
| 81  | B19W, C17Y, F12W   |           |
| 82  | C17Y, C17W   |           |
| 83  | D05V   |           |
| 84  | D16X, J17Z   |           |
| 85  | J18Z   |           |
| 86  | J19Z, K11W, K11Z   |           |
| 87  | K11W, K12Z   |           |
| 88  | F14X, K16X   |           |
| 89  | L12X   |           |
| 90  | L14X   |           |
| 91  | M09S   |           |
| 92  | M09S   |           |
| 93  | DUMMY LOCATION   |           |

- NOTES:
- ASSEMBLE PER ITEM 90S
  - MASK ALL AREAS MARKED DUMMY BEFORE FLOW SOLDERING.
  - LOCATE PIN 1 OF DIPS AS SHOWN UNLESS OTHERWISE SPECIFIED.
  - SOLID BAND INDICATES CATHODE OF DIODE
  - REMOVE PIN 3 OF ITEM 6 (Y11) BEFORE INSTALLING
  - REMOVE PIN 4 OF ITEM 3 (Y08) BEFORE INSTALLING
  - INSTALL SPEAKER (ITEM 9) IN .187 DIA HOLE IN LOCATION L10 PER VIEW S-S.
  - INSTALL SOCKET (ITEM 96) BEFORE ADDING ITEM 42
  - INSTALL CONNECTORS (ITEM 2) PER VIEW A
  - HAND INSERT ITEM 50 (SWITCH 8) AFTER FLOW SOLDERING PROCESS. DO NOT CRIMP LEADS. HAND SOLDER.
  - HAND INSERT THE FOLLOWING COMPONENTS OR ADJUST CLINCHER FOR 45° CLINCH.  
C06Z, E06X, E13X, E16X, F06X, F10Y, H05Y, H10Y, J03X, M06Z, M10E, C10W, C15X, F07W, F07X, F13Z, J08W, K07X, L06W, L09X, M09T, M11W, M09S, D15Z, M09Y, L09Y, C13W, C17S, J17W, J11X, K11W, K11Y, K13X, L12X, L14X, E17X, C16X, D16X, C17T

|                      |      |                               |              |
|----------------------|------|-------------------------------|--------------|
| MTRL                 |      | HONEYWELL                     |              |
|                      |      | HONEYWELL INFORMATION SYSTEMS |              |
|                      |      | LOC BIL U.S.A.                |              |
| 88188733-801A CH-MAP |      | ASSEMBLY DRAWING              |              |
| DR                   |      | BE2TCY                        |              |
| SCALE                | CODE | SIZE                          | DWG NO.      |
| 1/1                  | NML  | D                             | 60130730-102 |
| APPD P. GAGNON       |      | SH                            | REV          |
|                      |      | 1/1                           | B            |

THIS PRINT CONTAINS PROPRIETARY INFORMATION OF HONEYWELL INC. AND IS NOT TO BE REPRODUCED OR USED FOR THE MANUFACTURE OR SALE OF THE SUBJECT MATTER ILLUSTRATED WITHOUT THE WRITTEN CONSENT OF HONEYWELL.

60130730-102

THE INFORMATION CONTAINED IN THIS DOCUMENT IS PROPRIETARY TO HONEYWELL INFORMATION SYSTEMS INC. AND IS INTENDED FOR INTERNAL HONEYWELL USE ONLY. SUCH INFORMATION MAY BE DISTRIBUTED TO OTHERS ONLY BY WRITTEN PERMISSION OF AN AUTHORIZED HONEYWELL OFFICIAL. THIS RESTRICTION DOES NOT APPLY TO VENDORS AND SUPPLIERS OF THIS DOCUMENT.

|  |     |                    |     | SIZE                                      | P.L. NO.                  | SHEET         | REV. |  |     |                  |  |  |  |                      |  |       |  |  |  |  |  |   |                           |               |  |                  |  |  |  |      |          |       |      |  |  |  |  |    |          |    |   |
|--|-----|--------------------|-----|---|---------------------------|---------------|------|--|-----|------------------|--|--|--|----------------------|--|-------|--|--|--|--|--|---|---------------------------|---------------|--|------------------|--|--|--|------|----------|-------|------|--|--|--|--|----|----------|----|---|
|  |     |                    |     | 770322                                    | TX                        | BKBD002A      | 1/ A |  |     |                  |  |  |  |                      |  |       |  |  |  |  |  |   |                           |               |  |                  |  |  |  |      |          |       |      |  |  |  |  |    |          |    |   |
| ITEM NO.   | P C | IDENTIFICATION NO. | S C | DRAWING TITLE                             | ASSEMBLY/QUANTITY         |               |      |  | U M |                  |  |  |  |                      |  |       |  |  |  |  |  |   |                           |               |  |                  |  |  |  |      |          |       |      |  |  |  |  |    |          |    |   |
|  |     |                    |     |   | 001                       |               |      |  |     |                  |  |  |  |                      |  |       |  |  |  |  |  |   |                           |               |  |                  |  |  |  |      |          |       |      |  |  |  |  |    |          |    |   |
| 1  | TD  | 60129887-004       | A   | KEYBOARD ASSY                             | 1                         |               |      |  | EA  |                  |  |  |  |                      |  |       |  |  |  |  |  |   |                           |               |  |                  |  |  |  |      |          |       |      |  |  |  |  |    |          |    |   |
| 2  | A   | 60126281-143       | P   | TECH ID TAG MARKING                       | 1                         |               |      |  | EA  |                  |  |  |  |                      |  |       |  |  |  |  |  |   |                           |               |  |                  |  |  |  |      |          |       |      |  |  |  |  |    |          |    |   |
| <table border="1" style="width:100%; border-collapse: collapse;"> <tr> <td colspan="4" style="text-align: center;"><b>Honeywell</b></td> <td colspan="2">UM - UNIT OF MEASURE</td> <td colspan="2">TITLE</td> </tr> <tr> <td colspan="4" style="text-align: center;">HONEYWELL INFORMATION SYSTEMS<br/>LOC. BILLERICA, MASSACHUSETTS, USA.</td> <td>EA - EACH<br/>CM - CENTIMETER<br/>G - GRAMS</td> <td>IN - INCHES<br/>OZ - OUNCE</td> <td colspan="2" style="text-align: center;">TTYC KEYBOARD</td> </tr> <tr> <td colspan="4">* NOT APPLICABLE</td> <td>SIZE</td> <td>P.L. NO.</td> <td>SHEET</td> <td>REV.</td> </tr> <tr> <td colspan="4"></td> <td>TX</td> <td>BKBD002A</td> <td>1/</td> <td>A</td> </tr> </table> |     |                    |     |   |                           |               |      |  |     | <b>Honeywell</b> |  |  |  | UM - UNIT OF MEASURE |  | TITLE |  | HONEYWELL INFORMATION SYSTEMS<br>LOC. BILLERICA, MASSACHUSETTS, USA. |  |  |  | EA - EACH<br>CM - CENTIMETER<br>G - GRAMS | IN - INCHES<br>OZ - OUNCE | TTYC KEYBOARD |  | * NOT APPLICABLE |  |  |  | SIZE | P.L. NO. | SHEET | REV. |  |  |  |  | TX | BKBD002A | 1/ | A |
| <b>Honeywell</b>   |     |                    |     | UM - UNIT OF MEASURE                      |                           | TITLE         |      |  |     |                  |  |  |  |                      |  |       |  |  |  |  |  |   |                           |               |  |                  |  |  |  |      |          |       |      |  |  |  |  |    |          |    |   |
| HONEYWELL INFORMATION SYSTEMS<br>LOC. BILLERICA, MASSACHUSETTS, USA.   |     |                    |     | EA - EACH<br>CM - CENTIMETER<br>G - GRAMS | IN - INCHES<br>OZ - OUNCE | TTYC KEYBOARD |      |  |     |                  |  |  |  |                      |  |       |  |  |  |  |  |   |                           |               |  |                  |  |  |  |      |          |       |      |  |  |  |  |    |          |    |   |
| * NOT APPLICABLE   |     |                    |     | SIZE                                      | P.L. NO.                  | SHEET         | REV. |  |     |                  |  |  |  |                      |  |       |  |  |  |  |  |   |                           |               |  |                  |  |  |  |      |          |       |      |  |  |  |  |    |          |    |   |
|  |     |                    |     | TX  | BKBD002A                  | 1/            | A    |  |     |                  |  |  |  |                      |  |       |  |  |  |  |  |   |                           |               |  |                  |  |  |  |      |          |       |      |  |  |  |  |    |          |    |   |

HS 951 DOES A DOCUMENT REVISION STATUS SHEET EXIST?  YES  NO  
S = SUBSTITUTE PARTS

THE INFORMATION CONTAINED IN THIS DOCUMENT IS PROPRIETARY TO HONEYWELL INFORMATION SYSTEMS INC. AND IS INTENDED FOR INTERNAL HONEYWELL USE ONLY. SUCH INFORMATION MAY BE DISTRIBUTED TO OTHERS ONLY BY WRITTEN PERMISSION OF AN AUTHORIZED HONEYWELL OFFICIAL. THIS RESTRICTION DOES NOT APPLY TO VENDORS AND SUPPLIERS OF THIS DOCUMENT.

|  |     |                    |              | SIZE                                      | P.L. NO.                  | SHEET         | REV. |     |     |                  |  |  |  |                      |  |       |  |  |  |  |  |   |                           |               |  |                              |  |  |  |      |          |       |      |  |  |  |  |    |          |    |   |
|--|-----|--------------------|--------------|---|---------------------------|---------------|------|-----|-----|------------------|--|--|--|----------------------|--|-------|--|--|--|--|--|---|---------------------------|---------------|--|------------------------------|--|--|--|------|----------|-------|------|--|--|--|--|----|----------|----|---|
|  |     |                    |              | 770322                                    | TD                        | 60129887      | 1/ E |     |     |                  |  |  |  |                      |  |       |  |  |  |  |  |   |                           |               |  |                              |  |  |  |      |          |       |      |  |  |  |  |    |          |    |   |
| ITEM NO.   | P C | IDENTIFICATION NO. | S C          | DRAWING TITLE                             | ASSEMBLY/QUANTITY         |               |      |     | U M |                  |  |  |  |                      |  |       |  |  |  |  |  |   |                           |               |  |                              |  |  |  |      |          |       |      |  |  |  |  |    |          |    |   |
|  |     |                    |              |   | 001                       | 002           | 003  | 004 |     |                  |  |  |  |                      |  |       |  |  |  |  |  |   |                           |               |  |                              |  |  |  |      |          |       |      |  |  |  |  |    |          |    |   |
| 1  | TD  | 60129760-001       | A            | KEYBOARD COVER ASSY                       | 1                         | -             | 1    | 1   | EA  |                  |  |  |  |                      |  |       |  |  |  |  |  |   |                           |               |  |                              |  |  |  |      |          |       |      |  |  |  |  |    |          |    |   |
| 2  | TD  | 60129760-002       | A            | KEYBOARD COVER ASSY                       | -                         | 1             | -    | -   | EA  |                  |  |  |  |                      |  |       |  |  |  |  |  |   |                           |               |  |                              |  |  |  |      |          |       |      |  |  |  |  |    |          |    |   |
| 3  | TD  | 60129759-001       | P            | KEYBOARD BASE                             | 1                         | 1             | 1    | 1   | EA  |                  |  |  |  |                      |  |       |  |  |  |  |  |   |                           |               |  |                              |  |  |  |      |          |       |      |  |  |  |  |    |          |    |   |
| 4  | A   | 04910095-002       | V            | KEYBOARD                                  | -                         | 1             | -    | -   | EA  |                  |  |  |  |                      |  |       |  |  |  |  |  |   |                           |               |  |                              |  |  |  |      |          |       |      |  |  |  |  |    |          |    |   |
| 5  | A   | 59732801-001       | V            | KEYBOARD-ENG A=N U=L                      | 1                         | -             | -    | -   | EA  |                  |  |  |  |                      |  |       |  |  |  |  |  |   |                           |               |  |                              |  |  |  |      |          |       |      |  |  |  |  |    |          |    |   |
| 6  | A   | 43168065-007       | V            | BUMPER                                    | 4                         | 4             | 4    | 4   | EA  |                  |  |  |  |                      |  |       |  |  |  |  |  |   |                           |               |  |                              |  |  |  |      |          |       |      |  |  |  |  |    |          |    |   |
| 7  | A   | 03010002-010       | V            | SCREW PH 6                                | 4                         | 4             | 4    | 4   | EA  |                  |  |  |  |                      |  |       |  |  |  |  |  |   |                           |               |  |                              |  |  |  |      |          |       |      |  |  |  |  |    |          |    |   |
| 8  | P   | 03020001-049       | V            | WASHER FLAT 6                             | 4                         | 4             | 4    | 4   | EA  |                  |  |  |  |                      |  |       |  |  |  |  |  |   |                           |               |  |                              |  |  |  |      |          |       |      |  |  |  |  |    |          |    |   |
| 9  | P   | 03020003-003       | V            | WASHER LOCK 6 STL                         | 4                         | 4             | 4    | 4   | EA  |                  |  |  |  |                      |  |       |  |  |  |  |  |   |                           |               |  |                              |  |  |  |      |          |       |      |  |  |  |  |    |          |    |   |
| 10   | TD  | 60129864-001       | A            | RIBBON CABLE ASSY                         | 1                         | 1             | 1    | 1   | EA  |                  |  |  |  |                      |  |       |  |  |  |  |  |   |                           |               |  |                              |  |  |  |      |          |       |      |  |  |  |  |    |          |    |   |
| *  | 13  | A                  | 59733784-XXX | D   | KEYBOARD                  | -             | -    | X   | -   |                  |  |  |  |                      |  |       |  |  |  |  |  |   |                           |               |  |                              |  |  |  |      |          |       |      |  |  |  |  |    |          |    |   |
| *  | 14  | A                  | 04910099-001 | V   | KEYBOARD                  | -             | -    | -   | 1   |                  |  |  |  |                      |  |       |  |  |  |  |  |   |                           |               |  |                              |  |  |  |      |          |       |      |  |  |  |  |    |          |    |   |
| *  | 15  | A                  | 60126281-XXX | P   | TECH ID TAG MARKING       | X             | X    | X   | X   |                  |  |  |  |                      |  |       |  |  |  |  |  |   |                           |               |  |                              |  |  |  |      |          |       |      |  |  |  |  |    |          |    |   |
| <table border="1" style="width:100%; border-collapse: collapse;"> <tr> <td colspan="4" style="text-align: center;"><b>Honeywell</b></td> <td colspan="2">UM - UNIT OF MEASURE</td> <td colspan="2">TITLE</td> </tr> <tr> <td colspan="4" style="text-align: center;">HONEYWELL INFORMATION SYSTEMS<br/>LOC. BILLERICA, MASSACHUSETTS, USA.</td> <td>EA - EACH<br/>CM - CENTIMETER<br/>G - GRAMS</td> <td>IN - INCHES<br/>OZ - OUNCE</td> <td colspan="2" style="text-align: center;">KEYBOARD ASSY</td> </tr> <tr> <td colspan="4">* ITEMS REVISED SINCE REV. D</td> <td>SIZE</td> <td>P.L. NO.</td> <td>SHEET</td> <td>REV.</td> </tr> <tr> <td colspan="4"></td> <td>TD</td> <td>60129887</td> <td>1/</td> <td>E</td> </tr> </table> |     |                    |              |   |                           |               |      |     |     | <b>Honeywell</b> |  |  |  | UM - UNIT OF MEASURE |  | TITLE |  | HONEYWELL INFORMATION SYSTEMS<br>LOC. BILLERICA, MASSACHUSETTS, USA. |  |  |  | EA - EACH<br>CM - CENTIMETER<br>G - GRAMS | IN - INCHES<br>OZ - OUNCE | KEYBOARD ASSY |  | * ITEMS REVISED SINCE REV. D |  |  |  | SIZE | P.L. NO. | SHEET | REV. |  |  |  |  | TD | 60129887 | 1/ | E |
| <b>Honeywell</b>   |     |                    |              | UM - UNIT OF MEASURE                      |                           | TITLE         |      |     |     |                  |  |  |  |                      |  |       |  |  |  |  |  |   |                           |               |  |                              |  |  |  |      |          |       |      |  |  |  |  |    |          |    |   |
| HONEYWELL INFORMATION SYSTEMS<br>LOC. BILLERICA, MASSACHUSETTS, USA.   |     |                    |              | EA - EACH<br>CM - CENTIMETER<br>G - GRAMS | IN - INCHES<br>OZ - OUNCE | KEYBOARD ASSY |      |     |     |                  |  |  |  |                      |  |       |  |  |  |  |  |   |                           |               |  |                              |  |  |  |      |          |       |      |  |  |  |  |    |          |    |   |
| * ITEMS REVISED SINCE REV. D   |     |                    |              | SIZE                                      | P.L. NO.                  | SHEET         | REV. |     |     |                  |  |  |  |                      |  |       |  |  |  |  |  |   |                           |               |  |                              |  |  |  |      |          |       |      |  |  |  |  |    |          |    |   |
|  |     |                    |              | TD  | 60129887                  | 1/            | E    |     |     |                  |  |  |  |                      |  |       |  |  |  |  |  |   |                           |               |  |                              |  |  |  |      |          |       |      |  |  |  |  |    |          |    |   |

HS 951 DOES A DOCUMENT REVISION STATUS SHEET EXIST?  YES  NO  
S = SUBSTITUTE PARTS

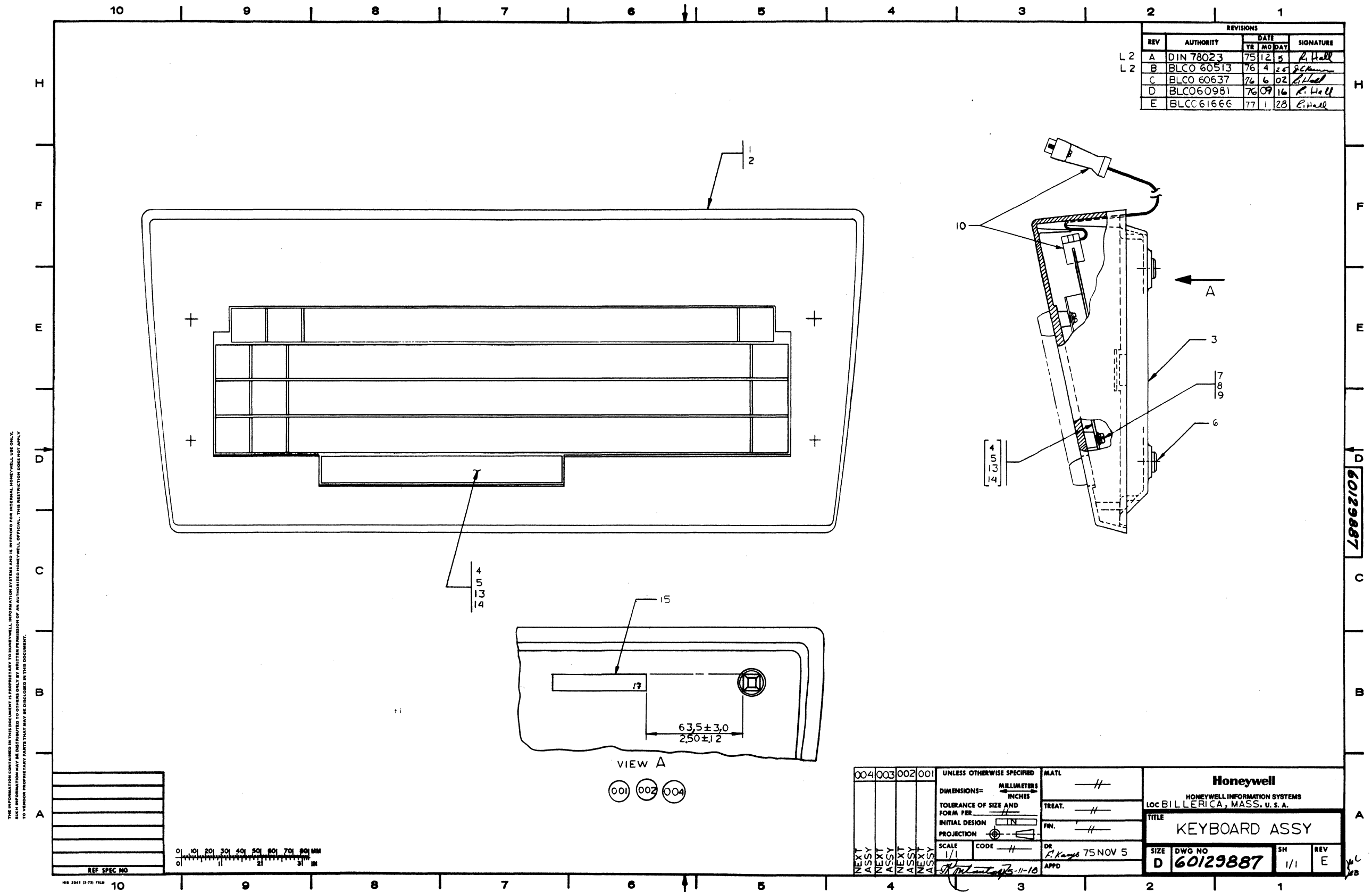

THE INFORMATION CONTAINED IN THIS DOCUMENT IS PROPRIETARY TO HONEYWELL INFORMATION SYSTEMS AND IS INTENDED FOR INTERNAL HONEYWELL USE ONLY. SUCH INFORMATION MAY BE OBTAINED FROM HONEYWELL INFORMATION SYSTEMS OR FROM AN AUTHORIZED HONEYWELL OFFICIAL. THIS RESTRICTION DOES NOT APPLY TO VENDOR PROPRIETARY PARTS THAT MAY BE DISCLOSED IN THIS DOCUMENT.

60129887

HONEYWELL PROPRIETARY AND CONFIDENTIAL

Keytops for Keyboard Assembly 04910099-001

|                    |              |    |    |    |    |    |    |    |    |    |    |       |      |                  |    |    |    |
|--------------------|--------------|----|----|----|----|----|----|----|----|----|----|-------|------|------------------|----|----|----|
| 1                  | 2            | 3  | 4  | 5  | 6  | 7  | 8  | 9  | 10 | 11 | 12 | 13    | 14   |                  |    |    |    |
| CLR                | F1           | F2 | F3 | F4 | F5 | F6 | F7 | ←  | ↑  | ↓  | →  | HOME  | XMIT |                  |    |    |    |
| 15                 | 16           | 17 | 18 | 19 | 20 | 21 | 22 | 23 | 24 | 25 | 26 | 27    | 28   | 29               | 30 | 31 | 32 |
| DEL                | !            | "  | #  | \$ | %  | &  | '  | (  | )  | =  | ?  | ^     |      | ERASE<br>EOP/EOL | 7  | 8  | 9  |
| 1                  | 2            | 3  | 4  | 5  | 6  | 7  | 8  | 9  | 0  | /  | ~  |       |      |                  |    |    |    |
| 33                 | 34           | 35 | 36 | 37 | 38 | 39 | 40 | 41 | 42 | 43 | 44 | 45    | 46   | 47               | 48 | 49 | 50 |
| END OF<br>MESSAGE  | Q            | W  | E  | R  | T  | Y  | U  | I  | O  | P  | ]  | *     | ESC  | BRK              | 4  | 5  | 6  |
|                    |              |    |    |    |    |    |    |    |    |    | }  | +     |      |                  |    |    |    |
| 51                 | 52           | 53 | 54 | 55 | 56 | 57 | 58 | 59 | 60 | 61 | 62 | 63    | 64   | 65               | 66 | 67 | 68 |
| CTL                | CAPS<br>LOCK | A  | S  | D  | F  | G  | H  | J  | K  | L  | :  | [     | \    | RETURN           | 1  | 2  | 3  |
|                    |              |    |    |    |    |    |    |    |    |    | :  | {     |      |                  |    |    |    |
| 69                 | 70           | 71 | 72 | 73 | 74 | 75 | 76 | 77 | 78 | 79 | 80 | 81    | 82   | 83               | 84 | 85 |    |
| SHIFT              | @            | Z  | X  | C  | V  | B  | N  | M  | <  | >  | -  | SHIFT | LF   | RPT              | O  | •  |    |
|                    |              |    |    |    |    |    |    |    | ,  | .  | _  |       |      |                  |    |    |    |
| 86                 |              |    |    |    |    |    |    |    |    |    |    |       |      |                  |    |    |    |
| [Empty Keytop Box] |              |    |    |    |    |    |    |    |    |    |    |       |      |                  |    |    |    |

NOTES

1. When ordering keytops, prefix each keytop part number with 04910099-1. For example, the part number for keytop Q is 04910099-134.
2. The part number for a complete set of keytops is 04910099-500.

HONEYWELL PROPRIETARY AND CONFIDENTIAL

THE INFORMATION CONTAINED IN THIS DOCUMENT IS PROPRIETARY TO HONEYWELL INFORMATION SYSTEMS INC. AND IS INTENDED FOR INTERNAL HONEYWELL USE ONLY. SUCH INFORMATION MAY BE DISTRIBUTED TO OTHERS ONLY BY WRITTEN PERMISSION OF AN AUTHORIZED HONEYWELL OFFICIAL. THIS RESTRICTION DOES NOT APPLY TO VENDORS AND SUPPLIERS THAT MAY BE DISPLAYED IN THIS DOCUMENT.

|   |     |                    |     | 770722   | SIZE<br>TB        | 59400394 | SHEET<br>1/F              | REV.<br>J            |             |           |     |    |
|---|-----|--------------------|-----|--|-------------------|----------|---------------------------|----------------------|-------------|-----------|-----|----|
| ITEM NO.  | P C | IDENTIFICATION NO. | S C | DRAWING TITLE  | ASSEMBLY/QUANTITY |          |                           |                      |             |           | U M |    |
|   |     |                    |     |  | 001               | 10A      | 50A                       |                      |             |           |     |    |
| 1   | C   | 59603385-001       | P   | CABLE  | 1                 | 10       | 50                        |                      |             |           |     | IN |
| 3   | B   | 43168200-001       | P   | HOOD   | 2                 | 2        | 2                         |                      |             |           |     | EA |
| 4   | B   | 43168204-002       | V   | BUSHING CABLE ADAPTR   | 2                 | 2        | 2                         |                      |             |           |     | EA |
| 5   | C   | 59603407-003       | P   | MARKER   | 1                 | 1        | 1                         |                      |             |           |     | EA |
| 6   | -   | 878B222.-100       | R   | SLEEVING THERMO  | INTCH             | INTCH    | INTCH                     |                      |             |           |     | EA |
| 6   | P   | 04170011-031       | V   | SLVG HEAT SHRINK SM  | 2                 | 240      | 1200                      |                      |             |           |     | IN |
| 7   | B   | 43223079-005       | V   | CONNECTOR 25-PIN   | 2                 | 2        | 2                         |                      |             |           |     | EA |
| 8   | B   | 43223079-111       | V   | CONTACT MALE BU  | 24                | -        | -                         |                      |             |           |     | EA |
| P0001   | D   | 59802021-020       | P   | CONNECTOR  | -                 | 1        | 1                         |                      |             |           |     | EA |
| P0002   | D   | 59802021-020       | P   | CONNECTOR  | -                 | 1        | 1                         |                      |             |           |     | EA |
|   |     |                    |     | UM - UNIT OF MEASURE<br>EA - EACH                      IN - INCHES<br>CM - CENTIMETER            OZ - OUNCE<br>G - GRAMS |                   |          | TITLE<br>CABLE ASSY W3-W4 |                      |             |           |     |    |
| Honeywell<br>HONEYWELL INFORMATION SYSTEMS<br>LOC. BILLERICA, MASSACHUSETTS, USA. |     |                    |     | * ITEMS REVISED SINCE REV. H   |                   |          | SIZE<br>TB                | P.L. NO.<br>59400394 | SHEET<br>1F | REV.<br>J |     |    |

NS 851  
DOES A DOCUMENT REVISION STATUS SHEET EXIST?

YES  
S = SUBSTITUTE PARTS

SIZE **B** 59B400394 SHEET 1 of 2 REV J

| ZONE | LTR | DESCRIPTION                         | DATE    | APPROVED    |
|------|-----|-------------------------------------|---------|-------------|
|      | C   | REVISED & REDRAWN                   | 95279-4 | [Signature] |
|      | D   | ADDED PT 6                          | 95317-2 | [Signature] |
|      | E   | DELETE PT 6 & ADD NOTE 5 & NEW PT 6 | 95474-3 | [Signature] |
|      | E1  | REV'D NOTE 3 & 5                    | RECORD  | [Signature] |

FOR DOCUMENT STATUS SEE REVISION STATUS SHEET

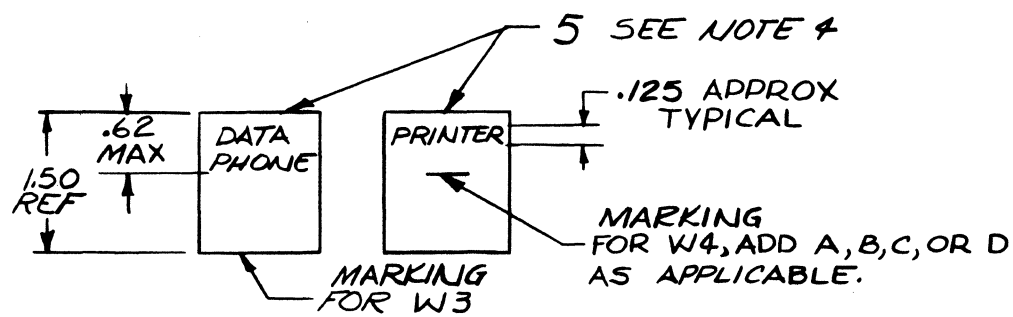
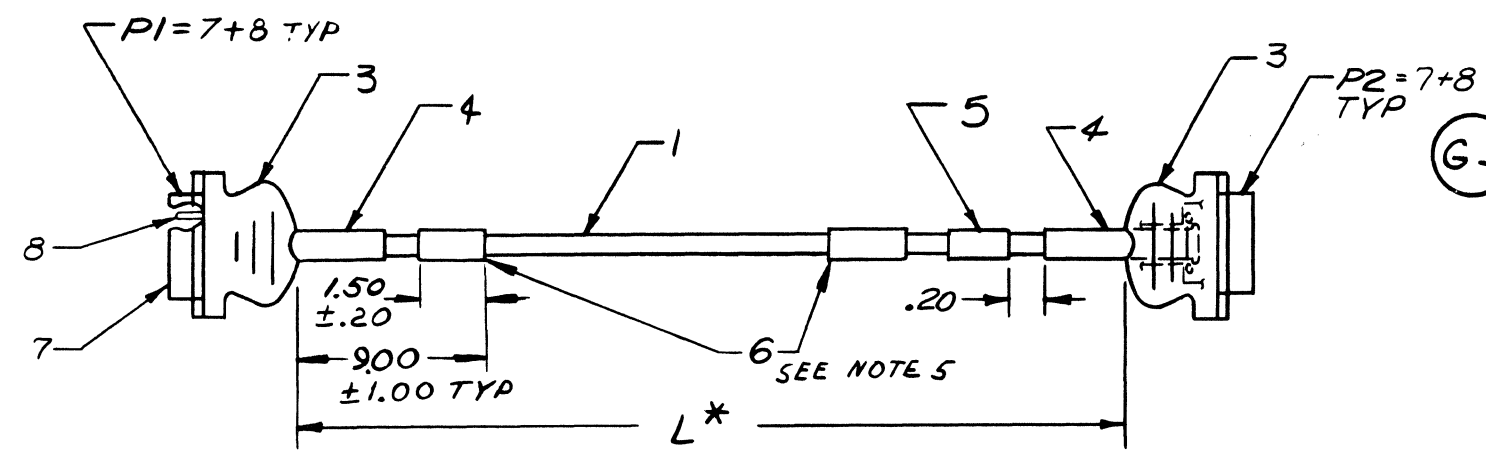

- (G) \*
- \* BULK CABLE LENGTH SHALL BE 1 FT. LONGER THAN GROUP LENGTH SPECIFIED.
  - 1. LENGTH & ASSEMBLY INSTRUCTIONS ARE DEFINED BY GROUP NO. AS FOLLOWS:  
 59B400394G  
 10 FT. INCREMENTS → LA0R1- ASSEMBLED CABLE OF SPECIFIED LENGTH  
 1 FT. INCREMENTS → B0R2- BULK CABLE & CONNECTOR PARTS NOT ASSEMBLED.\*
  - STANDARD LENGTH CABLE (50'-0") ASSEMBLED, MAY BE SPECIFIED AS GROUP G000.
  - 2. MAX PERMISSIBLE LENGTH - 50 FT.
  - 3. LENGTH TOL ±6.00 IN. UP TO 25 FT.  
 LENGTH TOL ±2.00 IN. FOR EACH ADDITIONAL 25 FT.
  - 4. PART 5 SHALL BE MARKED WITH A BALL POINT PEN OR TYPE WRITTEN AS SHOWN.
  - 5. MARK PT 6 PER 43A144110 AS A LOGIC CABLE.

**Honeywell**  
 HONEYWELL INFORMATION SYSTEMS  
 LOC OKLA. CITY, OKLA. U.S.A.

FOR DOCUMENT STATUS SEE REVISION STATUS SHEET

|   |            |           |  |     |    |    |
|---|------------|-----------|--|-----|----|----|
| UNLESS OTHERWISE SPECIFIED DIMENSIONS ARE IN INCHES. TOLERANCES ON: | SIGNATURES |           |  | DAY | MO | YR |
| FRACTIONS DECIMALS ANGLES   | DRAWN      | D. McFELY |  | 13  | 12 | 66 |
| ± .02 ±   | CHECKED    |           |  |     |    |    |
| ALL SURFACES ✓  | ISSUED     | S. ODEW   |  | 13  | 1  | 66 |
| MATL.   | ENGRG      | L. NAMEYH |  | 11  | 1  | 66 |
|   | MFG        | H. THOMAS |  | 13  | 1  | 66 |
|   | MATLS      |           |  |     |    |    |

**CABLE ASSEMBLY**  
 W3 - W4

SIZE **B** CODE IDENT NO. 59B400394 REV J

SCALE NONE SHEET 1 of 2

FN-902-F (12-65) PRINTED IN U.S.A.

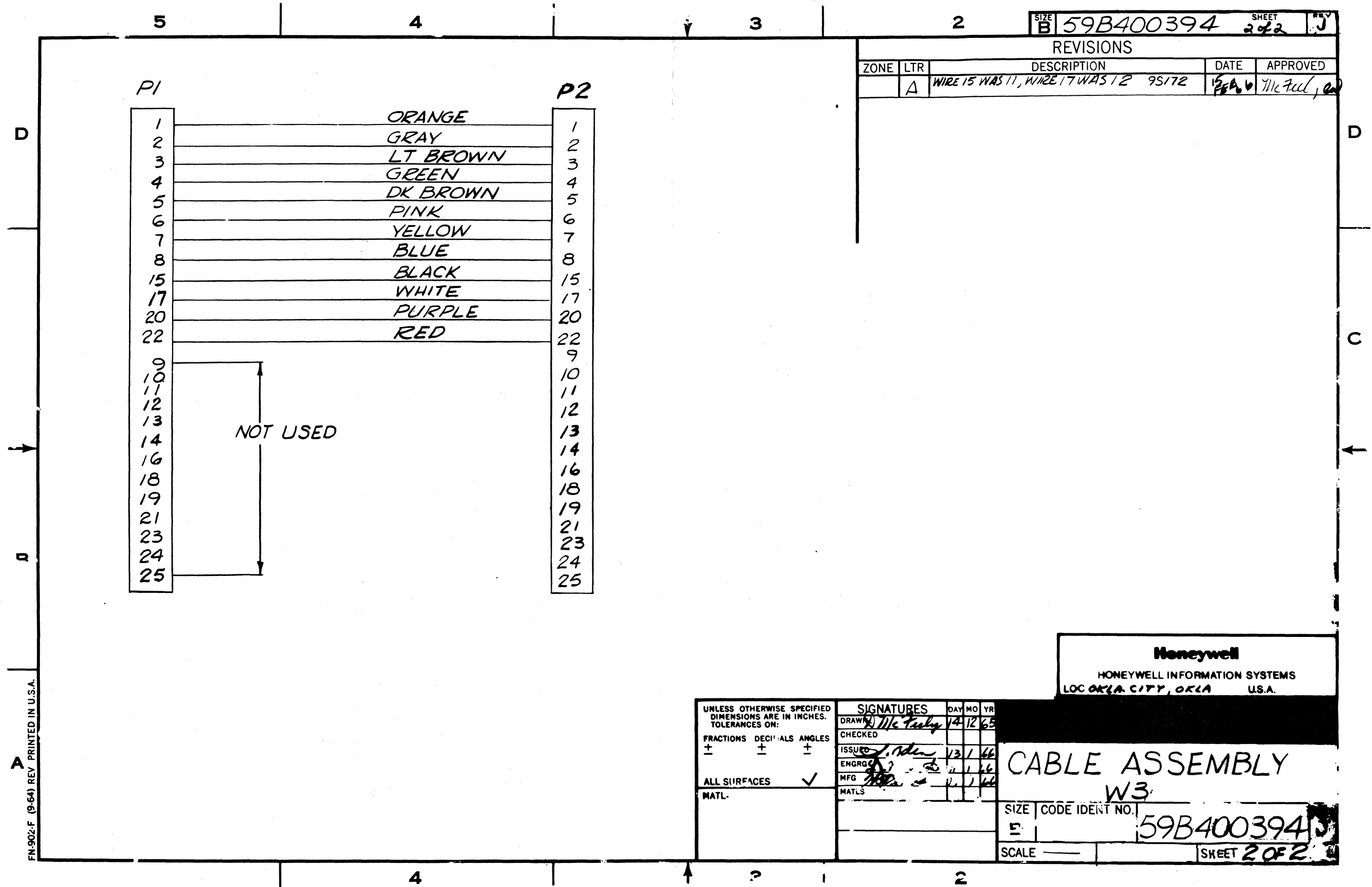

SIZE B 59B400394 SHEET 2 of 2 REV J

| REVISIONS |     |                                      |          |             |
|-----------|-----|--------------------------------------|----------|-------------|
| ZONE      | LTR | DESCRIPTION                          | DATE     | APPROVED    |
|           | A   | WIRE 15 WAS 11, WIRE 17 WAS 12 9S172 | 12/16/65 | Mike Feeley |

| P1 |          | P2 |
|----|----------|----|
| 1  | ORANGE   | 1  |
| 2  | GRAY     | 2  |
| 3  | LT BROWN | 3  |
| 4  | GREEN    | 4  |
| 5  | DK BROWN | 5  |
| 6  | PINK     | 6  |
| 7  | YELLOW   | 7  |
| 8  | BLUE     | 8  |
| 15 | BLACK    | 15 |
| 17 | WHITE    | 17 |
| 20 | PURPLE   | 20 |
| 22 | RED      | 22 |
| 9  | NOT USED | 9  |
| 10 |          | 10 |
| 11 |          | 11 |
| 12 |          | 12 |
| 13 |          | 13 |
| 14 |          | 14 |
| 16 |          | 16 |
| 18 |          | 18 |
| 19 |          | 19 |
| 21 |          | 21 |
| 23 |          | 23 |
| 24 |          | 24 |
| 25 |          | 25 |

**Honeywell**  
HONEYWELL INFORMATION SYSTEMS  
LOC OKLA CITY, OKLA U.S.A.

|  |                   |  |    |     |    |    |
|--|-------------------|--|----|-----|----|----|
| UNLESS OTHERWISE SPECIFIED<br>DIMENSIONS ARE IN INCHES.<br>TOLERANCES ON:<br>FRACTIONS DECIMALS ANGLES<br>+ ± ±<br>ALL SURFACES ✓<br>MATL. | SIGNATURES        |  |    | DAY | MO | YR |
|  | DRAWN Mike Feeley |  |    | 14  | 12 | 65 |
|  | CHECKED           |  |    |     |    |    |
|  | ISSUED            |  |    | 13  | 1  | 66 |
|  | ENGRG             |  |    | 11  | 1  | 66 |
| MFG  |                   |  | 11 | 1   | 66 |    |
| MATLS  |                   |  |    |     |    |    |

**CABLE ASSEMBLY**  
W3  
SIZE CODE IDENT NO. 59B400394  
SCALE SHEET 2 OF 2

FN-902-F (9-64) REV PRINTED IN U.S.A.



# XI REFERENCE DIAGRAMS

This section provides reference information which will assist a trained technician in isolating faults and making repairs below the Optimum Replaceable Unit (ORU) level should this become necessary. However, no specific repair procedures are given.

This section contains the following information.

| REFERENCE DRAWING                 | DRAWING NO.  | PAGE  |
|-----------------------------------|--------------|-------|
| CRT Terminal Schematic            | 60131981-001 | 11-3  |
| BP2TYC Schematic                  | 60130545-001 | 11-4  |
| Logic Block Diagrams              | 60130705-001 | 11-5  |
| Timing Diagrams                   | -            | 11-25 |
| Power Supply Adjustment Procedure | -            | 11-31 |
| CRT Display Specifications        | -            | 11-32 |
| Replacement of Keyboard Modules   | -            | 11-33 |
| Keyboard Output Codes             | -            | 11-34 |
| Logic Block Diagrams              | 60130734     | 11-35 |

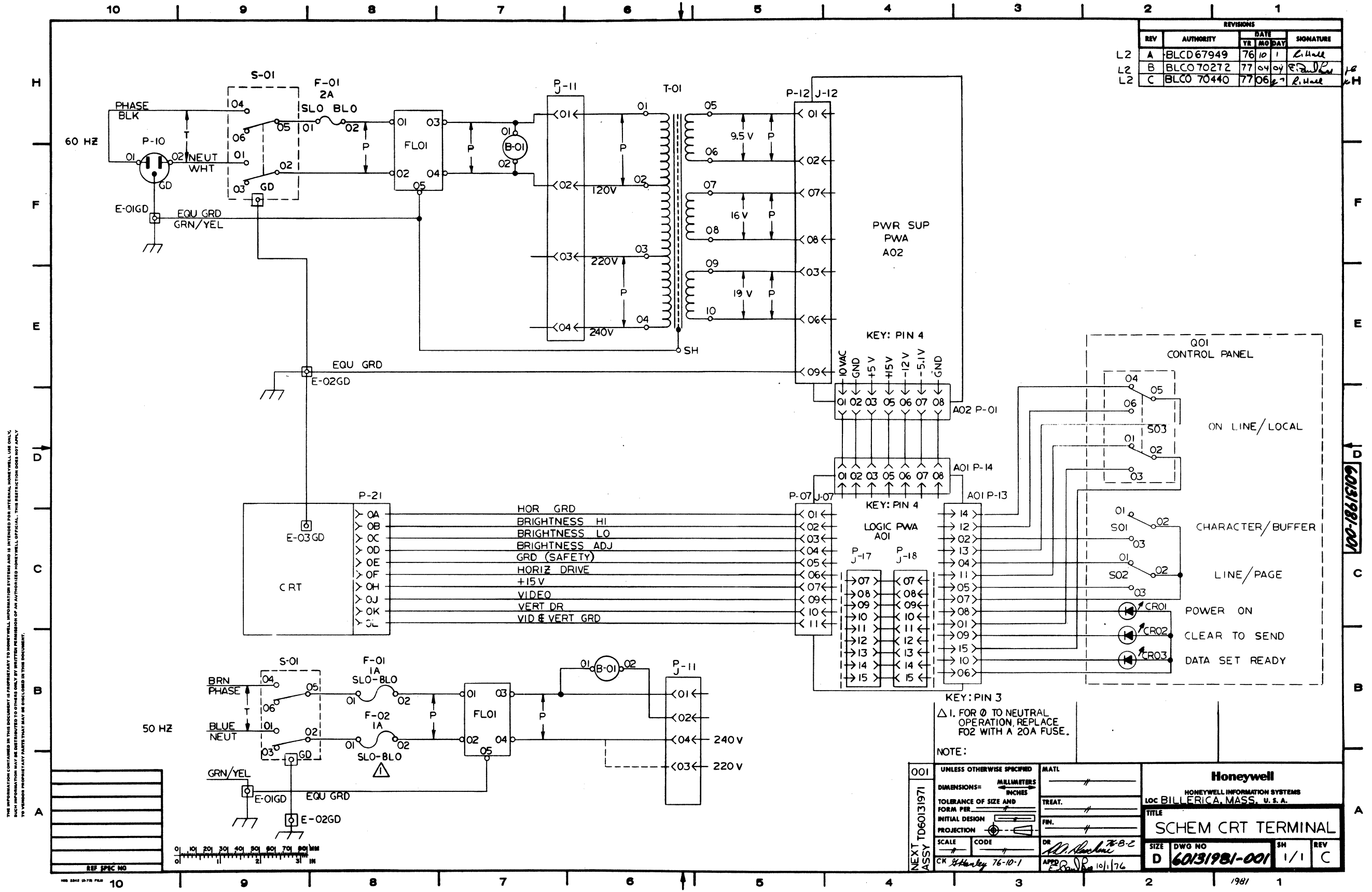

| REVISIONS |           |            |          |                   |
|-----------|-----------|------------|----------|-------------------|
| REV       | AUTHORITY | DATE       | BY       | SIGNATURE         |
| L2        | A         | BLCD67949  | 76 10 1  | L. Hall           |
| L2        | B         | BLC070272  | 77 04 04 | R. J. [Signature] |
| L2        | C         | BLC0 70440 | 77 06 27 | L. Hall           |

THE INFORMATION CONTAINED IN THIS DOCUMENT IS PROPRIETARY TO HONEYWELL INFORMATION SYSTEMS AND IS INTENDED FOR INTERNAL HONEYWELL USE ONLY. SUCH INFORMATION MAY BE DISCLOSED TO OTHERS ONLY BY WRITTEN PERMISSION OF AN AUTHORIZED HONEYWELL OFFICIAL. THIS RESTRICTION DOES NOT APPLY TO VENDOR PROPRIETARY PARTS THAT MAY BE INCLUDED IN THIS DOCUMENT.

100-18615109

|                                |   |                               |                |
|--------------------------------|---|-------------------------------|----------------|
| NEXT TD60131971<br>ASSY        | UNLESS OTHERWISE SPECIFIED                    | MATL                          |                |
|                                | DIMENSIONS = MILLIMETERS                      | TREAT.                        |                |
|                                | TOLERANCE OF SIZE AND FORM PER INITIAL DESIGN | FIN.                          |                |
|                                | PROJECTION                                    | DR                            |                |
| SCALE                          | CODE  | DR                            | M. [Signature] |
| CK                             | 76-10-1                                       | APPD                          | [Signature]    |
| Honeywell                      |   | HONEYWELL INFORMATION SYSTEMS |                |
| LOC BILLERICA, MASS., U. S. A. |   | TITLE                         |                |
| SCHEM CRT TERMINAL             |   | SIZE                          | DWG NO         |
| D                              | 60131981-001                                  | SH                            | REV            |
|                                |   | 1/1                           | C              |



HONEYWELL PROPRIETARY AND CONFIDENTIAL

LOGIC BLOCK DIAGRAM GLOSSARY/INDEX  
TTY-C CRT DISPLAY

DOCUMENT NO.  
GLH60130705

REV.  
A

BOARD NAME  
BE2TS

ASSEMBLY DOC. NO.  
60130702

PAGE 1 OF 5  
EDITED 01/25/77

| PAGE | TITLE                      |
|------|----------------------------|
| 1    | CONNECTORS                 |
| 2    | CLOCK AND HORIZONTAL SYNC  |
| 3    | VIDEO AND COUNT GENERATION |
| 4    | MEMORY                     |
| 5    | CHARACTER COUNT            |
| 6    | COMPARE                    |
| 7    | LINE COUNT AND BAUD RATE   |
| 8    | ADDRESS GENERATION         |
| 9    | UART                       |
| 10   | DATA BITS AND BELL         |
| 11   | WRITE CIRCUITRY            |
| 12   | COM. LINE LOGIC            |
| 13   | DECODE                     |
| 14   | LINE LOCK                  |
| 15   | KEYBOARD BITS              |

HONEYWELL PROPRIETARY AND CONFIDENTIAL

LOGIC BLOCK DIAGRAM GLOSSARY/INDEX  
TTY-C CRT DISPLAY

DOCUMENT NO.  
GL860130705

RFV.  
A

BOARD NAME ASSEMBLY DOC. NO.  
BE2TS 60130702

PAGE 2 OF 5  
EDITED 01/25/77

| SIGNAL NAME | ROW/COL /PAGE | N | SIGNAL NAME | ROW/COL /PAGE | N | SIGNAL NAME | ROW/COL /PAGE | N | SIGNAL NAME | ROW/COL /PAGE | N | SIGNAL NAME | ROW/COL /PAGE | N |
|-------------|---------------|---|-------------|---------------|---|-------------|---------------|---|-------------|---------------|---|-------------|---------------|---|
| •           | •             | • | •           | •             | • | •           | •             | • | •           | •             | • | •           | •             | • |
| OERMOX+00   | 01D07         | • | ACBDB2+0B   | 03C09         | • | ADEC06-00   | 01X13         | • | ALCL04+00   | 01A07         | • | BAUDG2-00   | 12X07         | • |
| OEROCT+00   | 06D07         | • | ACBDB2+0C   | 10A09         | • | ADEC06+00   | 06Y13         | • | ALCL08+00   | 04A07         | • | BAUDG2+00   | 12A07         | • |
| AABELL-00   | 07Z13         | • | ACBDB3+0A   | 05B09         | • | ADEC07-00   | 01X13         | • | ALCL16+00   | 01A07         | • | BAUDG3+00   | 12A07         | • |
| AACT81-00   | 01C05         | • | ACBDB3+0B   | 05C09         | • | ADEC07+00   | 07Y13         | • | AMLNFD-00   | 09X05         | • | BAUDG4+00   | 12A07         | • |
| AACT81+00   | 01D05         | • | ACBDB3+0C   | 11A09         | • | ADEC08-00   | 01X13         | • | AMSTCL+00   | 08Z07         | • | BAUDHI+00   | 11A12         | • |
| AACTDN-00   | 01B07         | • | ACBDB4+0A   | 07B09         | • | ADEC08+00   | 08Y13         | • | AMXCLR-00   | 04D14         | • | BAUDLL-00   | 13X07         | • |
| AACTUP-00   | 01B07         | • | ACBDB4+0B   | 07C09         | • | ADEC09-00   | 01X13         | • | AMXSL2-00   | 09D06         | • | BAUDRT-01   | 12D07         | • |
| AAHOME-00   | 08Z13         | • | ACBDB4+0C   | 12A09         | • | ADEC09+00   | 09Y13         | • | AMXSL2+00   | 07D06         | • | BAUDRT+00   | 11D07         | • |
| AALNCT-00   | 05D06         | • | ACBDB5+0A   | 09B09         | • | ADEC10-00   | 01X13         | • | AMXSTB-00   | 06Y07         | • | BAUDRT+01   | 11Z07         | • |
| AALNCT-0A   | 04D06         | • | ACBDB5+0B   | 09C09         | • | ADEC10+00   | 10Y13         | • | ANCT81-00   | 04D05         | • | BELL01-00   | 08A10         | • |
| •           | •             | • | •           | •             | • | •           | •             | • | •           | •             | • | •           | •             | • |
| AALNCT-0C   | 05C06         | • | ACBDB5+0C   | 07D09         | • | ADEC11-00   | 01X13         | • | ANCT81+00   | 04D05         | • | BELL01+00   | 07X10         | • |
| AAMODA+00   | 08X13         | • | ACBDB6+0A   | 11B09         | • | ADEC11+00   | 11Y13         | • | ANHOME-00   | 11X07         | • | BELL01+01   | 09A10         | • |
| AAMODb+00   | 09X13         | • | ACBDB6+0B   | 11C09         | • | ADEC13-00   | 01X13         | • | ANZRCT-00   | 04D05         | • | BELL01+02   | 09Y10         | • |
| AAMODc+00   | 10X13         | • | ACBDB6+0C   | 08D09         | • | ADEC13+00   | 12Y13         | • | ANZRCT+00   | 04D05         | • | BELL01+03   | 09Y10         | • |
| AAMODd+00   | 11X13         | • | ACBDB7+0A   | 13B09         | • | ADEC14-00   | 01X13         | • | APARER-00   | 01A10         | • | BELLCT+00   | 12A10         | • |
| AAMODE+00   | 12X13         | • | ACBDB7+0B   | 11D09         | • | ADEC14+00   | 13Y13         | • | APARER+00   | 01D09         | • | BELLEN+00   | 13X10         | • |
| AAPEEN-00   | 10Z07         | • | ACBDB7+0C   | 09D09         | • | ADEC15-00   | 01X13         | • | APARER+11   | 01X10         | • | BFWDCT+00   | 12A05         | • |
| AAROLL-00   | 05A07         | • | ACIN01+0A   | 04A05         | • | ADEC15+00   | 13A13         | • | APTSON+00   | 11Y10         | • | BLKVID-00   | 04D02         | • |
| AAROLL+00   | 08A07         | • | ACIN02+0A   | 04A05         | • | ADR000+00   | 01A08         | • | APTYON-00   | 12Y10         | • | BLKVID-XX   | 08Z02         | • |
| AARRST-00   | 01X08         | • | ACIN04+0A   | 04A05         | • | ADR001+00   | 01A08         | • | APTYON-0A   | 12Z10         | • | BLKVID+00   | 08D02         | • |
| •           | •             | • | •           | •             | • | •           | •             | • | •           | •             | • | •           | •             | • |
| AAZRCT+00   | 02D05         | • | ACIN08+0A   | 04A05         | • | ADR002+00   | 01A08         | • | APTYON-0B   | 12D10         | • | BLKVID+0X   | 03D02         | • |
| ABCOMP-00   | 13X06         | • | ACIN16+0A   | 07B05         | • | ADR003+00   | 04A08         | • | ARCLRY-00   | 07Y11         | • | BLKVID+XX   | 08Z02         | • |
| ABELRS-00   | 13A10         | • | ACIN32+0A   | 01A05         | • | ADR003+01   | 01A08         | • | ARTRDY+00   | 01D09         | • | BRIADJ+00   | 07A01         | • |
| ABILL1-00   | 02A11         | • | ACIN64+0A   | 01A05         | • | ADR004+00   | 04A08         | • | ATOLFD-00   | 10A07         | • | BRIGHT+00   | 07A01         | • |
| ABUF01+00   | 03A06         | • | ACLRDY-00   | 07Z11         | • | ADR004+01   | 07A08         | • | AVIDEO-00   | 01C03         | • | BRIGLO+00   | 07A01         | • |
| ABUF02+00   | 03A06         | • | ACOMUN-13   | 01A01         | • | ADR005+00   | 04A08         | • | AXICKF-00   | 10Y06         | • | BRKCN-00    | 09X11         | • |
| ABUF03+00   | 03A06         | • | ACOMUN+09   | 05A02         | • | ADR006+00   | 04A08         | • | AXICKF+00   | 10Z06         | • | BRKLTH-00   | 11A11         | • |
| ABUF04+00   | 03A06         | • | ACTLNF-00   | 12Z05         | • | ADR007+00   | 10B08         | • | AXLNMD-00   | 10A06         | • | BRKLTH+00   | 09A11         | • |
| ABUF05+00   | 03A06         | • | ACTNDN-00   | 07Z07         | • | ADR008+00   | 10B08         | • | AXLNMD+00   | 08A06         | • | BUFHMD-00   | 08X12         | • |
| ABUF06+00   | 03A06         | • | ACTNUP-00   | 09Z07         | • | ADR009+00   | 07A08         | • | AXMSN1-0A   | 02X12         | • | BUFINH-00   | 05A14         | • |
| •           | •             | • | •           | •             | • | •           | •             | • | •           | •             | • | •           | •             | • |
| ABUF07+00   | 01A06         | • | ADEC00-00   | 01X13         | • | ADRCRY+00   | 08B08         | • | AXMSN1-0X   | 10D06         | • | BUFINH+00   | 05X14         | • |
| ABUF08+00   | 01A06         | • | ADEC00+00   | 01Y13         | • | ADRXMT-00   | 06A14         | • | AXMSN1+00   | 11Z06         | • | BUFMOD-00   | 03Z12         | • |
| ABUF09+00   | 01A06         | • | ADEC01-00   | 01X13         | • | ADRXMT+00   | 06X14         | • | AXMSN1+0A   | 11X06         | • | BUFMOD+00   | 06D01         | • |
| ABUF10+00   | 01A06         | • | ADEC01+00   | 02Y13         | • | AEXBIT-00   | 03Z14         | • | AXMSN1+0X   | 10D06         | • | BVIDEO+00   | 08A03         | • |
| ABUF11+00   | 01A06         | • | ADEC02-00   | 01X13         | • | AEXBIT+00   | 05Y14         | • | AXPGMD-00   | 07A06         | • | CARDET+01   | 04X12         | • |
| ABUF12+00   | 01A06         | • | ADEC02+00   | 03Y13         | • | AFWDCT-00   | 13X05         | • | AXPGMD+00   | 05A06         | • | CARRTN-00   | 12Z13         | • |
| ACBDB1+0A   | 01B09         | • | ADEC03-00   | 01X13         | • | AKYSTB-00   | 06Z07         | • | AYLOAD-00   | 08D14         | • | CCTR01+00   | 04B05         | • |
| ACBDB1+0B   | 01C09         | • | ADEC03+00   | 04Y13         | • | AKYSTB+00   | 09C06         | • | BACKEN-00   | 04Y14         | • | CCTR02+00   | 04B05         | • |
| ACBDB1+0C   | 09A09         | • | ADEC04-00   | 01X13         | • | ALCL01+00   | 01A07         | • | BACKEN+00   | 04X14         | • | CCTR04+00   | 04B05         | • |
| ACBDB2+0A   | 03B09         | • | ADEC04+00   | 05Y13         | • | ALCL02+00   | 01A07         | • | BAUDG1+00   | 12A07         | • | CCTR08+00   | 04B05         | • |
| •           | •             | • | •           | •             | • | •           | •             | • | •           | •             | • | •           | •             | • |

NOTE AN ASTERIK IN THE COLUMN(S) LABELED N INDICATES A NARRATIVE FOR THE GIVEN SIGNAL(S). NARRATIVES ARE SHOWN AT THE END OF THE REPORT.

HONEYWELL PROPRIETARY AND CONFIDENTIAL

LOGIC BLOCK DIAGRAM GLOSSARY/INDEX  
TTY-C CRT DISPLAY

DOCUMENT NO.  
GLB60130705

REV.  
A

BOARD NAME  
BE2T5

ASSEMBLY DOC. NO.  
60130702

PAGE 3 OF 5  
EDITED 01/25/77

| SIGNAL NAME | ROW/COL /PAGE | N | SIGNAL NAME | ROW/COL /PAGE | N | SIGNAL NAME | ROW/COL /PAGE | N | SIGNAL NAME | ROW/COL /PAGE | N | SIGNAL NAME | ROW/COL /PAGE | N |
|-------------|---------------|---|-------------|---------------|---|-------------|---------------|---|-------------|---------------|---|-------------|---------------|---|
| CCTR16+00   | 01B05         | . | COMDAT+03   | 13Y12         | . | CTSEND-00   | 13X12         | . | DATBT6+0C   | 06A13         | . | DOTCLD-00   | 02A02         | . |
| CCTR32-00   | 03C05         | . | COMDAT+13   | 09Y12         | . | CTSEND+00   | 08Y12         | . | DATBT7-00   | 07X13         | . | DOTCT1+10   | 02A02         | . |
| CCTR32+00   | 01B05         | . | COMDAT+14   | 12D06         | . | CTSND1-00   | 06D01         | . | DATBT7-0C   | 09D10         | . | DOTCT2+10   | 02A02         | . |
| CCTR64-00   | 02C05         | . | COMDAT+15   | 09Z12         | . | CURSDN-00   | 03Z13         | . | DATBT7-YY   | 07Y14         | . | DOTCT4+10   | 02A02         | . |
| CCTR64+00   | 01B05         | . | COMDAT+16   | 07Y12         | . | CURSFLF-00  | 05Z13         | . | DATBT7+0C   | 07A13         | . | DTFWRD-00   | 11X05         | . |
| CCTRBO+00   | 04B05         | . | COMDAT+19   | 12Z06         | . | CURSFLF-1X  | 08D05         | . | DATBTS+00   | 08Z14         | . | DTFWRD+00   | 05Y11         | . |
| CCTRCA+00   | 04B05         | . | COMDAT+23   | 06D01         | . | CURSFLF+00  | 08Y05         | . | DATCLK+00   | 08A11         | . | DVIDEO-00   | 03D03         | . |
| CCTRSM-01   | 13Y10         | . | COMDAT+40   | 06D01         | . | CURSRT-00   | 04Z13         | . | DATCON-00   | 07X11         | . | DVIDEO+00   | 01D03         | . |
| CGBIT1+00   | 01B03         | . | COMEIA-01   | 01A01         | . | CURSUP-00   | 02Z13         | . | DATCON-1Z   | 01A11         | . | DVIDEO+01   | 07C01         | . |
| CGBIT2+00   | 01B03         | . | COMEIA-00   | 01D01         | . | CVIDEO-02   | 07B03         | . | DATCON+00   | 02X11         | . | EIACFD+00   | 01A01         | . |
| CGBIT3+00   | 01B03         | . | COMEIA-01   | 07B01         | . | CVIDEO+01   | 04C03         | . | DATERR+00   | 06D01         | . | EIACFD+1X   | 05A12         | . |
| CGBIT4+00   | 01B03         | . | COMEIA+00   | 11Y12         | . | CVIDEO+02   | 05C03         | . | DATRDY+00   | 08X11         | . | EIACTS-01   | 07B01         | . |
| CGBIT5+00   | 01B03         | . | COMINJ+00   | 01D09         | . | DATAIN-00   | 03C15         | . | DATSTR+00   | 02A14         | . | EIACTS+00   | 01D01         | . |
| CHIPEN-01   | 11C08         | . | COMIN2+00   | 01D09         | . | DATBT1-0A   | 03D10         | . | DCLEAR-00   | 12Y03         | . | EIACTS+1X   | 12X12         | . |
| CHIPEN+01   | 08P08         | . | COMIN3+00   | 01D09         | . | DATBT1-0C   | 03Z10         | . | DCLEAR-17   | 06D06         | . | EIADSR+00   | 01A01         | . |
| CHMCMF+00   | 04B06         | . | COMIN4+00   | 01D09         | . | DATBT1-0D   | 03Y10         | . | DCLEAR-21   | 13A03         | . | EIADSR+1X   | 01A14         | . |
| CLKCON-00   | 03A11         | . | COMIN5+00   | 01D09         | . | DATBT1+0C   | 01A13         | . | DCLEAR+00   | 12Y03         | . | EIARTS-01   | 07B01         | . |
| CLOCK1-00   | 11A02         | . | COMIN6+00   | 01D09         | . | DATBT2-0A   | 04D10         | . | DCLEAR+07   | 03Y11         | . | EIASRS-01   | 01A01         | . |
| CLOCK1-01   | 13B02         | . | COMIN7+00   | 01D09         | . | DATBT2-0C   | 04Z10         | . | DCLEAR+17   | 07C06         | . | ELERAS-00   | 11Z13         | . |
| CLOCK1-02   | 12X02         | . | COMLIN-05   | 01A01         | . | DATBT2-0D   | 04Y10         | . | DCLFAR+21   | 13A03         | . | ELEVNX+00   | 03D07         | . |
| CLOCK1-03   | 10Y02         | . | COMLIN-11   | 07D12         | . | DATBT2+0C   | 02A13         | . | DCLRDRY-00  | 06Z11         | . | ELEVNY+00   | 02D07         | . |
| CLOCK1-04   | 11Z02         | . | COMLIN+01   | 07Z12         | . | DATBT3-0A   | 05D10         | . | DCLRDRY+00  | 06Z11         | . | ENBCLK+00   | 01D11         | . |
| CLOCK1+00   | 11D02         | . | COMLIN+17   | 06D12         | . | DATBT3-0C   | 05Z10         | . | DECB67-00   | 11A13         | . | ENSPAC-0A   | 01Z10         | . |
| CLOCK1+01   | 11Y02         | . | COMRES-13   | 05A02         | . | DATBT3-0D   | 05Y10         | . | DECB67+00   | 12A13         | . | ENSPAC+00   | 01Y10         | . |
| CLRPLS-21   | 13X03         | . | COMRRT-01   | 06X12         | . | DATBT3+0C   | 03A13         | . | DFCDEL-00   | 13X13         | . | EPGCLR-00   | 10Z13         | . |
| CLRRDY-00   | 06X11         | . | COMTRE+00   | 01D09         | . | DATBT4-0A   | 06D10         | . | DEXBIT-00   | 07A11         | . | ERSBLK-00   | 04A03         | . |
| CLRRDY+00   | 06X11         | . | CON7NX+00   | 10A13         | . | DATBT4-0C   | 06Z10         | . | DISENA-00   | 03D06         | . | ERSBLK+88   | 04A03         | . |
| CNT064-00   | 06B08         | . | CON7PX+00   | 08A13         | . | DATBT4-0D   | 06Y10         | . | DISENA+00   | 13A08         | . | ERSCAP+00   | 06A03         | . |
| CNT064+00   | 07Y08         | . | CRCOMP-05   | 13Z06         | . | DATBT4+0C   | 04A13         | . | DLITDT+00   | 07A15         | . | ERSRES+00   | 07A03         | . |
| CNT064+10   | 07A08         | . | CRCOMP-5X   | 13Y06         | . | DATBT5-00   | 05X13         | . | DLYEXT-00   | 01A12         | . | ESCAPE+00   | 11D13         | . |
| COMCLK-00   | 12Y06         | . | CRCOMP+01   | 04D03         | . | DATBT5-0A   | 07D10         | . | DLYINH+00   | 06D11         | . | ESCAPX-00   | 13A15         | . |
| COMDAT-00   | 12Z12         | . | CRCOMP+02   | 07D03         | . | DATBT5-0C   | 07Z10         | . | DMYB04-00   | 05A11         | . | ETXSW1+00   | 01A09         | . |
| COMDAT-01   | 06A12         | . | CRCOMP+04   | 10D03         | . | DATBT5-0D   | 07Y10         | . | DMYB06-00   | 03C15         | . | ETXSW2+00   | 01A09         | . |
| COMDAT-03   | 07X12         | . | CRDYCK-00   | 06Y11         | . | DATBT5+0C   | 05A13         | . | DMYB18+00   | 08B08         | . | ETXSW3+00   | 05A09         | . |
| COMDAT-11   | 11D12         | . | CRSSTP-00   | 09X14         | . | DATBT6-00   | 06X13         | . | DMYC05-00   | 05Z11         | . | ETXSW4+00   | 01A09         | . |
| COMDAT-14   | 09D12         | . | CRSSTP+00   | 07X14         | . | DATBT6-0A   | 08D10         | . | DMYC08+00   | 12A06         | . | FDXRTS+00   | 01D12         | . |
| COMDAT-19   | 12Z06         | . | CRSXMT-00   | 13Z13         | . | DATBT6-0B   | 02Z10         | . | DMYD02-00   | 03X11         | . | FREQ1P+00   | 11A14         | . |
| COMDAT-23   | 11Z12         | . | CRTSND+00   | 01Z12         | . | DATBT6-0C   | 08Z10         | . | DMYE11+00   | 01D09         | . | FREQ2P+00   | 13A14         | . |
| COMDAT+01   | 01D09         | . | CTFWRD+00   | 10Y05         | . | DATBT6-0D   | 08Y10         | . | DMYL02+00   | 04A10         | . | FREQ3P+00   | 12A14         | . |
| COMDAT+02   | 06Y12         | . | CTMXVD-00   | 08Y02         | . | DATBT6-YY   | 08Y14         | . | DMYL17-00   | 01A12         | . | FREQ4P+00   | 13Y14         | . |

NOTE AN ASTERIK IN THE COLUMN(S) LABELED N INDICATES A NARRATIVE FOR THE GIVEN SIGNAL(S). NARRATIVES ARE SHOWN AT THE END OF THE REPORT.

HONEYWELL PROPRIETARY AND CONFIDENTIAL

LOGIC BLOCK DIAGRAM GLOSSARY/INDEX  
TTY-C CRT DISPLAY

DOCUMENT NO.  
GLB60130705

REV.  
A

BOARD NAME ASSEMBLY DOC. NO.  
BE2T5 60130702

PAGE 4 OF 5  
EDITED 01/25/77

| SIGNAL NAME | ROW/COL /PAGE | N | SIGNAL NAME | ROW/COL /PAGE | N | SIGNAL NAME | ROW/COL /PAGE | N | SIGNAL NAME | ROW/COL /PAGE | N | SIGNAL NAME | ROW/COL /PAGE | N |
|-------------|---------------|---|-------------|---------------|---|-------------|---------------|---|-------------|---------------|---|-------------|---------------|---|
| FREQCP+00   | 10Y14         | . | KBDD85+00   | 10D15         | . | LOADSP-00   | 02D06         | . | MCNT08-00   | 04C07         | . | NX81CT+00   | 10X07         | . |
| FWDLNF-00   | 08X05         | . | KBDD85+0Z   | 01C01         | . | LOADSP-0C   | 06C06         | . | MCNT08+00   | 01B07         | . | NZERCT-00   | 04D05         | . |
| FWDLNF+00   | 09Y05         | . | KBDD86+00   | 10D15         | . | LOADSP+00   | 02D06         | . | MCNT16-00   | 05C07         | . | NZERCT+00   | 04D05         | . |
| HDXRTS-00   | 01Y12         | . | KBDD86+0Z   | 01C01         | . | LSTCHR-00   | 13A05         | . | MCNT16+00   | 04X07         | . | PARINH+00   | 09C01         | . |
| HEREIS-00   | 01C01         | . | KBDD87+00   | 01B15         | . | LSTCHR+00   | 01X11         | . | MEPLEE+00   | 07A05         | . | PARSEL+00   | 09C01         | . |
| HRSYNC-00   | 04Y02         | . | KBDD87+0Z   | 01C01         | . | MBIT01+01   | 07D04         | . | MLNCMP+00   | 01B06         | . | PCLEAR-00   | 01Z13         | . |
| HRSYNC-01   | 03Z02         | . | KBDD88+0Z   | 01C01         | . | MBIT01+0A   | 01A04         | . | MRCT01-00   | 04X08         | . | PCLEAR-XX   | 02D13         | . |
| HRSYNC-02   | 06Z02         | . | KBDMUX+00   | 11X15         | . | MBIT01+0B   | 04A04         | . | MRCT01-0A   | 13B08         | . | PCLEAR+XX   | 01D13         | . |
| HRSYNC-03   | 03Y02         | . | KBDS7B-00   | 13A11         | . | MBIT01+0C   | 13A04         | . | MRCT01-0B   | 12B08         | . | PELOAD-00   | 09D05         | . |
| HRSYNC-04   | 05D02         | . | KBDS7B-02   | 03A10         | . | MBIT02+01   | 07D04         | . | MRCT01+00   | 13C08         | . | PGCMPR-00   | 08C06         | . |
| HRSYNC-22   | 09Z02         | . | KBDS7B+01   | 13X11         | . | MBIT02+0A   | 07A04         | . | MRCT02+00   | 10A08         | . | PGCMPR+00   | 07B06         | . |
| HRSYNC+00   | 04Z02         | . | KBDS7B+02   | 11D11         | . | MBIT02+0B   | 10A04         | . | MRCT04+00   | 10A08         | . | PGMODE-00   | 06D01         | . |
| HRSYNC+01   | 01D02         | . | KBDS7B+0Z   | 01C01         | . | MBIT02+0C   | 13X04         | . | MRCT08+00   | 10A08         | . | PGMODE+00   | 08D13         | . |
| HRSYNC+02   | 01Z02         | . | LCLOAD-00   | 08C03         | . | MBIT03+01   | 07D04         | . | MRCT16+00   | 10A08         | . | PGXMIT-00   | 09D13         | . |
| HRSYNC+04   | 06D02         | . | LCLOAD-01   | 11C03         | . | MBIT03+0A   | 01B04         | . | MS132C+00   | 08D11         | . | PPADTR-00   | 13A12         | . |
| HRSYNC+22   | 09D02         | . | LCLOAD-02   | 07C03         | . | MBIT03+0B   | 04B04         | . | NAXCKC+00   | 07X07         | . | PPADTR+01   | 07B01         | . |
| HRSYNC+24   | 10A05         | . | LCLOAD-03   | 11B03         | . | MBIT03+0C   | 13Y04         | . | NAXCKF-00   | 12A15         | . | PPARCD-00   | 01D01         | . |
| INBIT1+0A   | 04A15         | . | LCLOAD+01   | 08B03         | . | MBIT04+01   | 07D04         | . | NCARTN-00   | 11D05         | . | PPARCD-01   | 07B01         | . |
| INBIT1+0B   | 01A15         | . | LCLOAD+02   | 12Z03         | . | MBIT04+0A   | 07B04         | . | NCLRDY-00   | 08Y11         | . | PPARCD+01   | 07A12         | . |
| INBIT1+0C   | 05X15         | . | LLCASE-00   | 04C05         | . | MBIT04+0B   | 10B04         | . | NCLRDY+00   | 02Y11         | . | PPARCD+0X   | 08A12         | . |
| INBIT2+00   | 05Y15         | . | LLCASE-01   | 05A02         | . | MBIT04+0C   | 13Z04         | . | NCROMP-04   | 12X03         | . | PPARTS-01   | 07B01         | . |
| INBIT3+00   | 05Z15         | . | LNCT01+00   | 01A03         | . | MBIT05+01   | 07D04         | . | NCROMP+04   | 12A03         | . | PPARTS+00   | 02D12         | . |
| INCCCT-00   | 03D11         | . | LNCT02+00   | 01A03         | . | MBIT05+0A   | 01C04         | . | NCRTEN+00   | 12Z15         | . | PPATXD-00   | 03Y12         | . |
| INCTSX-00   | 03X14         | . | LNCT04+00   | 01A03         | . | MBIT05+0B   | 04C04         | . | NCR7SD-00   | 12Y15         | . | PPATXD-01   | 07B01         | . |
| INCTSX-0A   | 03A14         | . | LNCT08-00   | 05B03         | . | MBIT05+0C   | 12D04         | . | NCR7SD+00   | 05D12         | . | PPDSRS+0Z   | 11X12         | . |
| INCTSX-0B   | 04A14         | . | LNCT08+00   | 01A03         | . | MBIT06+01   | 09D04         | . | NDTCOM-1X   | 01Z11         | . | PTRXXX-00   | 11D10         | . |
| INDCTS+00   | 06D01         | . | LNCT09-00   | 06B03         | . | MBIT06+0A   | 07C04         | . | NDTFWD-00   | 11Y05         | . | PULLUP+00   | 10D07         | . |
| INHCLK-00   | 12Y02         | . | LNCT09+00   | 06C03         | . | MBIT06+0B   | 10C04         | . | NENSPC-00   | 02Z11         | . | PULLUP+01   | 06D01         | . |
| INLNFD-00   | 11Z05         | . | LNFEED-00   | 10D13         | . | MBIT06+0C   | 11D04         | . | NEWDR+01    | 06A01         | . | PULLUP+02   | 13A02         | . |
| INMSTC-00   | 08Y07         | . | LNFEED+00   | 09X07         | . | MBIT07+01   | 07D04         | . | NEWSTB+00   | 02X10         | . | PULLUP+03   | 12D05         | . |
| IVIDEU+00   | 05D15         | . | LNFEED+10   | 01C06         | . | MBIT07+0A   | 01D04         | . | NEXBIT-00   | 05A11         | . | PULLUP+04   | 01D06         | . |
| KBDBKH-00   | 01C01         | . | LNFEED+11   | 03C06         | . | MBIT07+0B   | 04D04         | . | NFWDCT-00   | 13Y05         | . | PULLUP+06   | 11X11         | . |
| KBDD81+00   | 10D15         | . | LNFRFQ-10   | 12Z14         | . | MBIT07+0C   | 10D04         | . | NINLFD-00   | 10Z05         | . | PULLUP+08   | 07A07         | . |
| KBDD81+0Z   | 01C01         | . | LNFRFQ-20   | 11Z14         | . | MBIT16+00   | 06C05         | . | NLNFD-00    | 09Y07         | . | PULLUP+09   | 07A05         | . |
| KBDD82+00   | 10D15         | . | LNFRFQ+00   | 11Y14         | . | MCNT01-00   | 01C07         | . | NLONG1+00   | 01Y11         | . | PULLUP+10   | 09Z12         | . |
| KBDD82+0Z   | 01C01         | . | LNMODE-00   | 06D01         | . | MCNT01+00   | 01B07         | . | NODATA-00   | 12D15         | . | PWRISO+00   | 01D14         | . |
| KBDD83+00   | 10D15         | . | LNMODE+00   | 06D13         | . | MCNT02-00   | 02C07         | . | NTWHRE-00   | 04D05         | . | PWRISO+0A   | 01Z14         | . |
| KBDD83+0Z   | 01C01         | . | LNRADE-00   | 04C06         | . | MCNT02+00   | 01B07         | . | NTWHRE+00   | 04D05         | . | PWRISO+0B   | 02Z14         | . |
| KBDD84+00   | 10D15         | . | LNRADE+00   | 04C06         | . | MCNT04-00   | 03C07         | . | NW81CT+00   | 12Y05         | . | PWRONI+00   | 06D01         | . |
| KBDD84+0Z   | 01C01         | . | LNXM1T-00   | 09Z13         | . | MCNT04+00   | 01B07         | . | NWMDA+00    | 04X13         | . | PWRRST-00   | 07A14         | . |

NOTE AN ASTERIK IN THE COLUMN(S) LABELED N INDICATES A NARRATIVE FOR THE GIVEN SIGNAL(S). NARRATIVES ARE SHOWN AT THE END OF THE REPORT.

HONEYWELL PROPRIETARY AND CONFIDENTIAL

LOGIC BLOCK DIAGRAM GLOSSARY/INDEX  
TTY-C CRT DISPLAY

DOCUMENT NO. REV.  
GLB60130705 A

BOARD NAME ASSEMBLY DOC. NO.  
BE2TS 60130702

PAGE 5 OF 5  
EDITED 01/25/77

| SIGNAL NAME | ROW/COL /PAGE | N | SIGNAL NAME | ROW/COL /PAGE | N | SIGNAL NAME | ROW/COL /PAGE | N | SIGNAL NAME | ROW/COL /PAGE | N | SIGNAL NAME | ROW/COL /PAGE | N |
|-------------|---------------|---|-------------|---------------|---|-------------|---------------|---|-------------|---------------|---|-------------|---------------|---|
| PWRTON-00   | 11Y10         | . | RPCT01+00   | 09Y11         | . | STXMIT+00   | 09A15         | . | WDULIT-00   | 05D13         | . |             |               |   |
| PWRTON+00   | 11Z10         | . | RPCT02-00   | 12D11         | . | STXMIT+5C   | 11Y15         | . | WRCT08-XX   | 04Z11         | . |             |               |   |
| RAMC00+00   | 04X02         | . | RPCT02+00   | 09Y11         | . | SYNCT+00    | 08X02         | . | WRCT08+00   | 03X11         | . |             |               |   |
| RAMC00+XX   | 07D11         | . | RPCTXX+00   | 09Y11         | . | TERVN5-00   | 08A12         | . | WRCTSM-00   | 03X11         | . |             |               |   |
| RAMC01+00   | 04X02         | . | RPTKEY-01   | 12Y11         | . | TESTCK-00   | 12Z02         | . | WRENAB-00   | 05Z11         | . |             |               |   |
| RAMC02+00   | 04X02         | . | RPTKEY-02   | 12Z11         | . | THRCNT+00   | 12Y12         | . | X81CTN+00   | 07Y07         | . |             |               |   |
| RAMC04-00   | 07Y02         | . | RPTKEY-04   | 10D11         | . | TMXCAP+00   | 03A12         | . | XERMOY+00   | 04D07         | . |             |               |   |
| RAMC04+00   | 04X02         | . | RPTKEY-0Z   | 01C01         | . | TMXRES+00   | 03A12         | . | XLDSRT-00   | 04Z14         | . |             |               |   |
| RAMCRY+00   | 04X02         | . | RPTKEY+00   | 12A11         | . | TWTHRE+00   | 05D07         | . | XLDSRT+00   | 05Y14         | . |             |               |   |
| RCNT01-00   | 01Y08         | . | RPTKEY+02   | 10Z11         | . | TXDATO-01   | 01A01         | . | XMTFWD-00   | 12X05         | . |             |               |   |
| RCNT01+00   | 01Y08         | . | RTSEXT-00   | 04D12         | . | TXDATO-11   | 05Y12         | . | XMTFWD+00   | 10X05         | . |             |               |   |
| RCNT02+00   | 03Y08         | . | RTSHDX-00   | 01X12         | . | URCLMX+00   | 11A05         | . | XMTRST-00   | 08D06         | . |             |               |   |
| RCNT04+00   | 03Y08         | . | RTSHDX+00   | 03X12         | . | URSEL1-00   | 09X15         | . | XYCRSN-00   | 06Z13         | . |             |               |   |
| RCNT08-00   | 03C08         | . | RTSLTH-00   | 06Z12         | . | URSEL1+00   | 09X15         | . | XYLOAD-00   | 07D14         | . |             |               |   |
| RCNT08+00   | 03Y08         | . | RTSLTH+00   | 04Z12         | . | URSEL2-00   | 09Y15         | . | XZERCT-00   | 11A07         | . |             |               |   |
| RCNT11+10   | 04Z08         | . | RTSPLS-00   | 04Y12         | . | URSEL2+00   | 09Y15         | . | XZERCT+00   | 08X07         | . |             |               |   |
| RCNT16+00   | 03Y08         | . | RWLIN-00    | 05D11         | . | URTHRE+00   | 01D09         | . | Y81CTN-00   | 10Y07         | . |             |               |   |
| RDULIT-00   | 04D13         | . | RWLIN+00    | 04D11         | . | VCCT16+00   | 01X02         | . | YLDSRT-00   | 05Z14         | . |             |               |   |
| RESETC-00   | 01Z08         | . | S00000+00   | 11Y07         | . | VCCT32-00   | 02Y02         | . | YLDSRT+00   | 05Y14         | . |             |               |   |
| RLNFED-00   | 09A07         | . | S00001+00   | 11Y07         | . | VCCT32+00   | 01X02         | . |             |               | . |             |               |   |
| ROW004-02   | 06Z08         | . | S00002+00   | 11Y07         | . | VCCT64+00   | 01X02         | . |             |               | . |             |               |   |
| ROW004-04   | 09C08         | . | S00003+00   | 11Y07         | . | VCLOAD-00   | 01Y02         | . |             |               | . |             |               |   |
| ROW004-14   | 10C08         | . | SENDIX-1Z   | 11Y06         | . | VIDRES-00   | 12D14         | . |             |               | . |             |               |   |
| ROW004+00   | 01D08         | . | SENDIX+0Z   | 01C01         | . | VRCT01-00   | 09C03         | . |             |               | . |             |               |   |
| ROW004+02   | 10B08         | . | SET81X-00   | 08Z05         | . | VRCT01+00   | 09C03         | . |             |               | . |             |               |   |
| ROW004+03   | 10B08         | . | SET81X+00   | 07D05         | . | VRCT02+00   | 09A03         | . |             |               | . |             |               |   |
| ROW004+04   | 10B08         | . | SETZRO-00   | 10D05         | . | VRCT04-00   | 09B03         | . |             |               | . |             |               |   |
| ROW004+0A   | 05D08         | . | STBENL+00   | 02Y10         | . | VRCT04+00   | 09A03         | . |             |               | . |             |               |   |
| ROW004+0B   | 06D08         | . | STBINH+00   | 03B15         | . | VRCT08-00   | 07X02         | . |             |               | . |             |               |   |
| ROW008-00   | 11D08         | . | STBLTH-00   | 05X10         | . | VRCT08+00   | 09A03         | . |             |               | . |             |               |   |
| ROW008-01   | 07Z08         | . | STBLTH+00   | 03X10         | . | VRCT16+00   | 09A03         | . |             |               | . |             |               |   |
| ROW008+00   | 03D08         | . | STBRST-00   | 02A10         | . | VRCTCO+00   | 09A03         | . |             |               | . |             |               |   |
| ROW008+0A   | 10D08         | . | STBRST+00   | 02A10         | . | VRCTCU+00   | 12A06         | . |             |               | . |             |               |   |
| ROW008+0B   | 09D08         | . | STOPBL-00   | 07A10         | . | VRCTOX+00   | 09Z11         | . |             |               | . |             |               |   |
| ROX004-01   | 08Z08         | . | STOPBL+00   | 04A10         | . | VRLOAD-00   | 05A02         | . |             |               | . |             |               |   |
| ROY004-01   | 08D08         | . | STPBIT+00   | 09C01         | . | VTSYNC-00   | 08A02         | . |             |               | . |             |               |   |
| ROZ004-01   | 07D08         | . | STPBIT+99   | 01D15         | . | VTSYNC-01   | 10A02         | . |             |               | . |             |               |   |
| RPCT00-00   | 09D11         | . | STPCLR+00   | 10B03         | . | VTSYNC+02   | 05A02         | . |             |               | . |             |               |   |
| RPCT00+00   | 09Y11         | . | STRSTX-00   | 12X15         | . | VTSYNC+11   | 10X02         | . |             |               | . |             |               |   |
| RPCT01-00   | 08Z11         | . | STXMIT-00   | 11A15         | . | WDLINH-00   | 03D14         | . |             |               | . |             |               |   |

NOTE AN ASTERIK IN THE COLUMN(S) LABELED N INDICATES A NARRATIVE FOR THE GIVEN SIGNAL(S). NARRATIVES ARE SHOWN AT THE END OF THE REPORT.



60130705

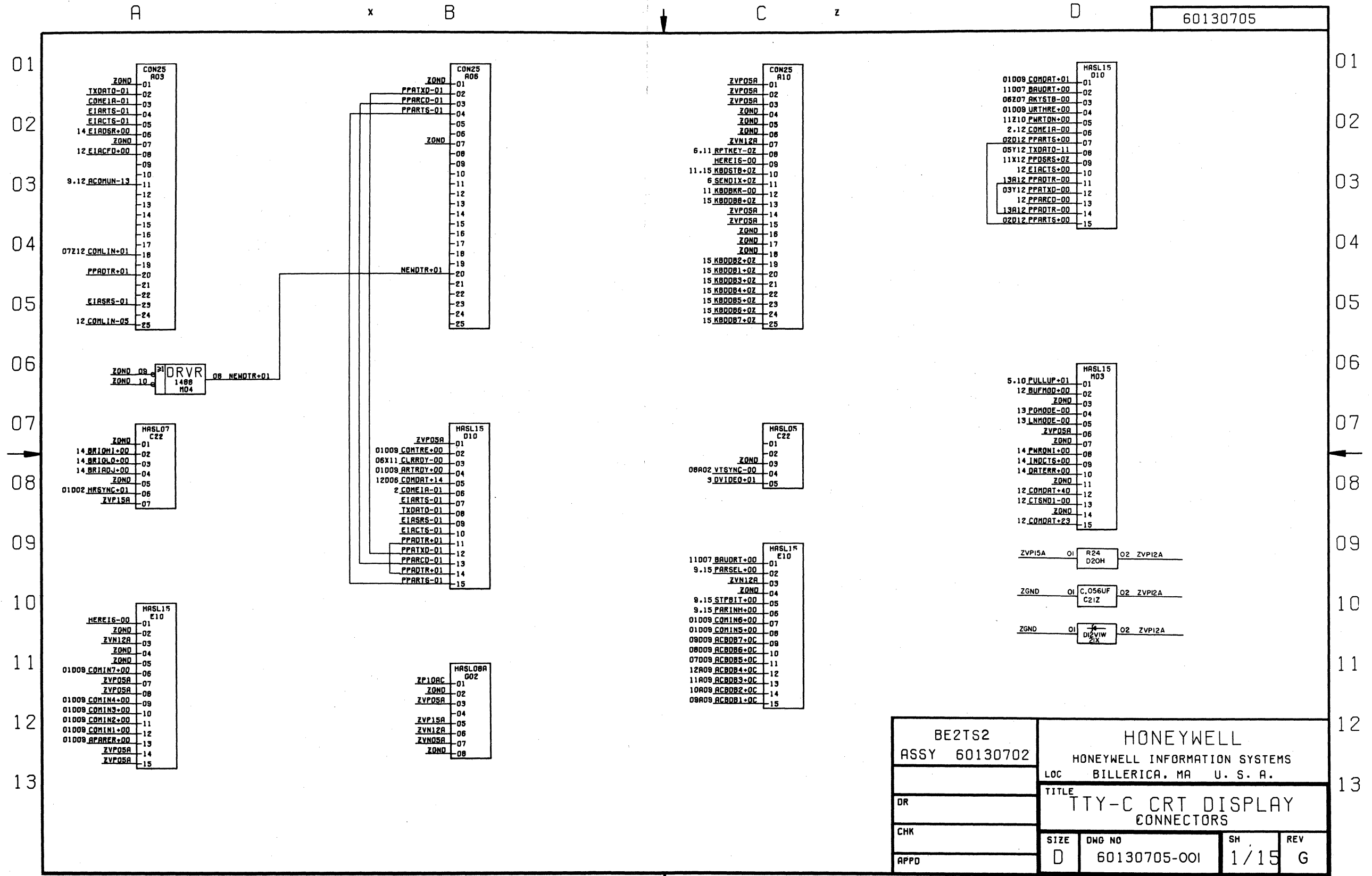

|               |      |                                       |      |     |  |
|---------------|------|---------------------------------------|------|-----|--|
| BE2TS2        |      | HONEYWELL                             |      |     |  |
| ASSY 60130702 |      | HONEYWELL INFORMATION SYSTEMS         |      |     |  |
|               |      | LOC BILLERICA, MA U. S. A.            |      |     |  |
| DR            |      | TITLE<br>TTY-C CRT DISPLAY CONNECTORS |      |     |  |
| CHK           | SIZE | DWG NO                                | SH   | REV |  |
| APPD          | D    | 60130705-001                          | 1/15 | G   |  |

60130705

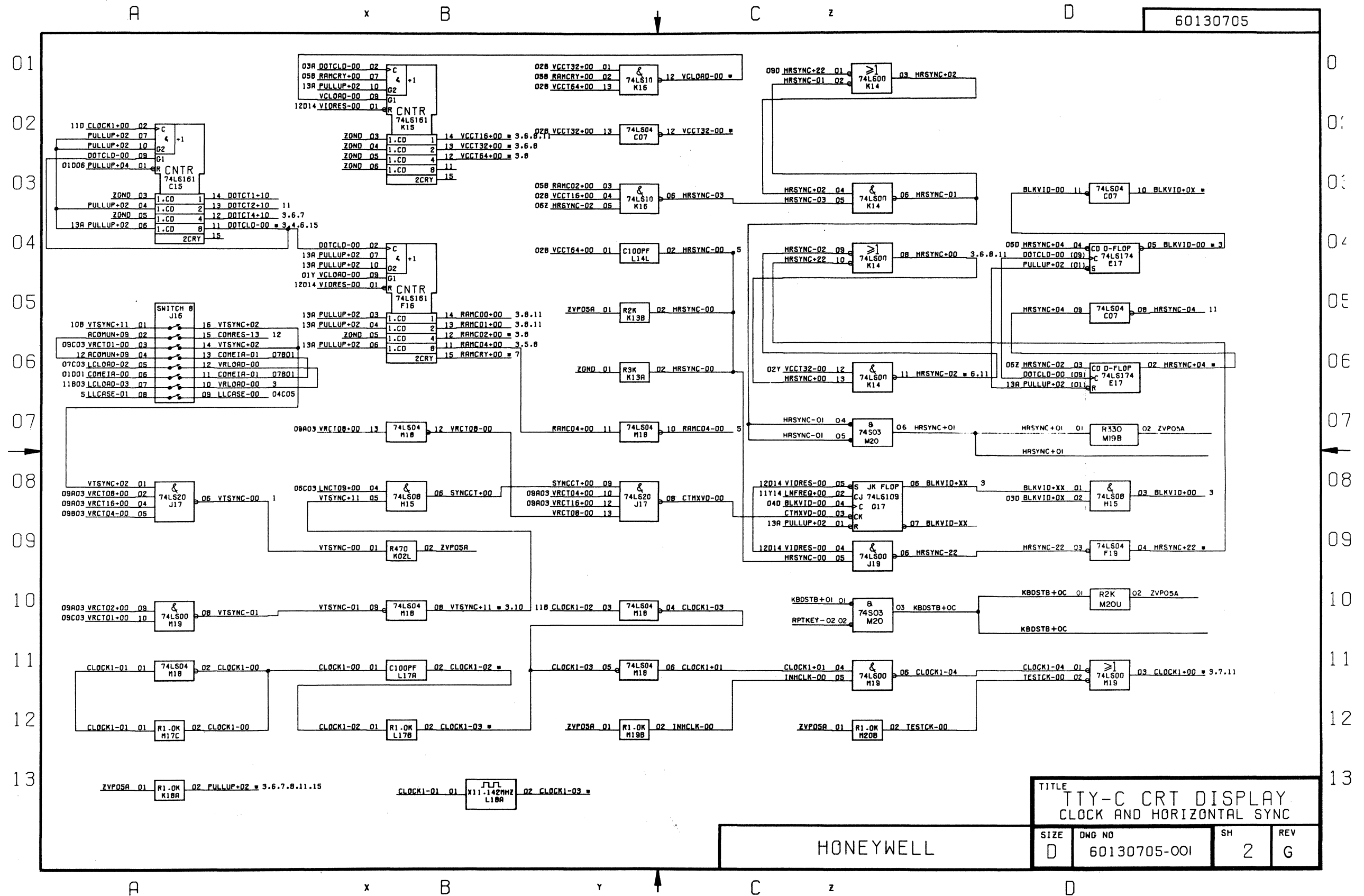



60130705

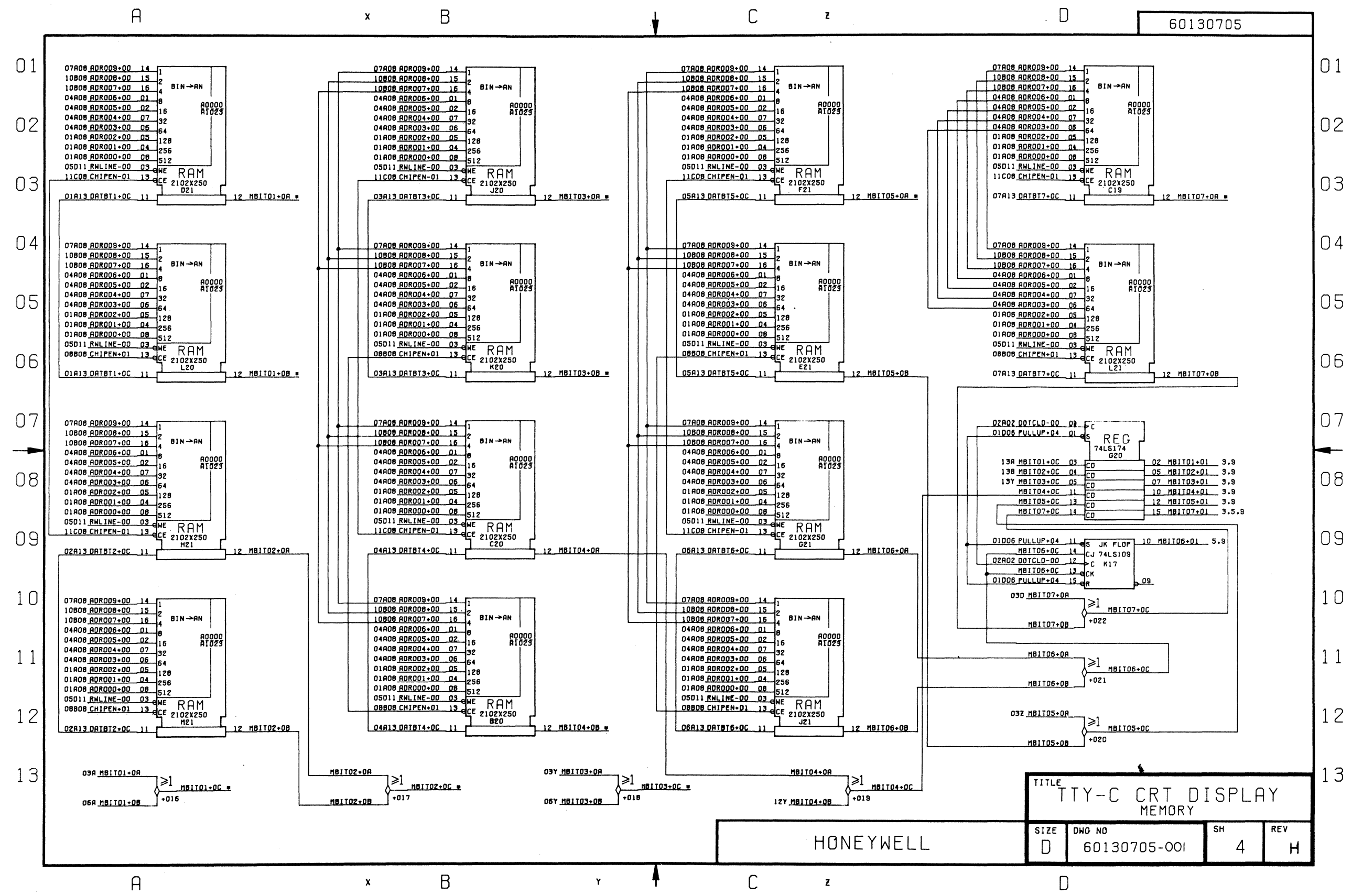

|                                      |                        |         |          |
|--------------------------------------|------------------------|---------|----------|
| TITLE<br>TTY-C CRT DISPLAY<br>MEMORY |                        |         |          |
| SIZE<br>D                            | DWG NO<br>60130705-001 | SH<br>4 | REV<br>H |

HONEYWELL

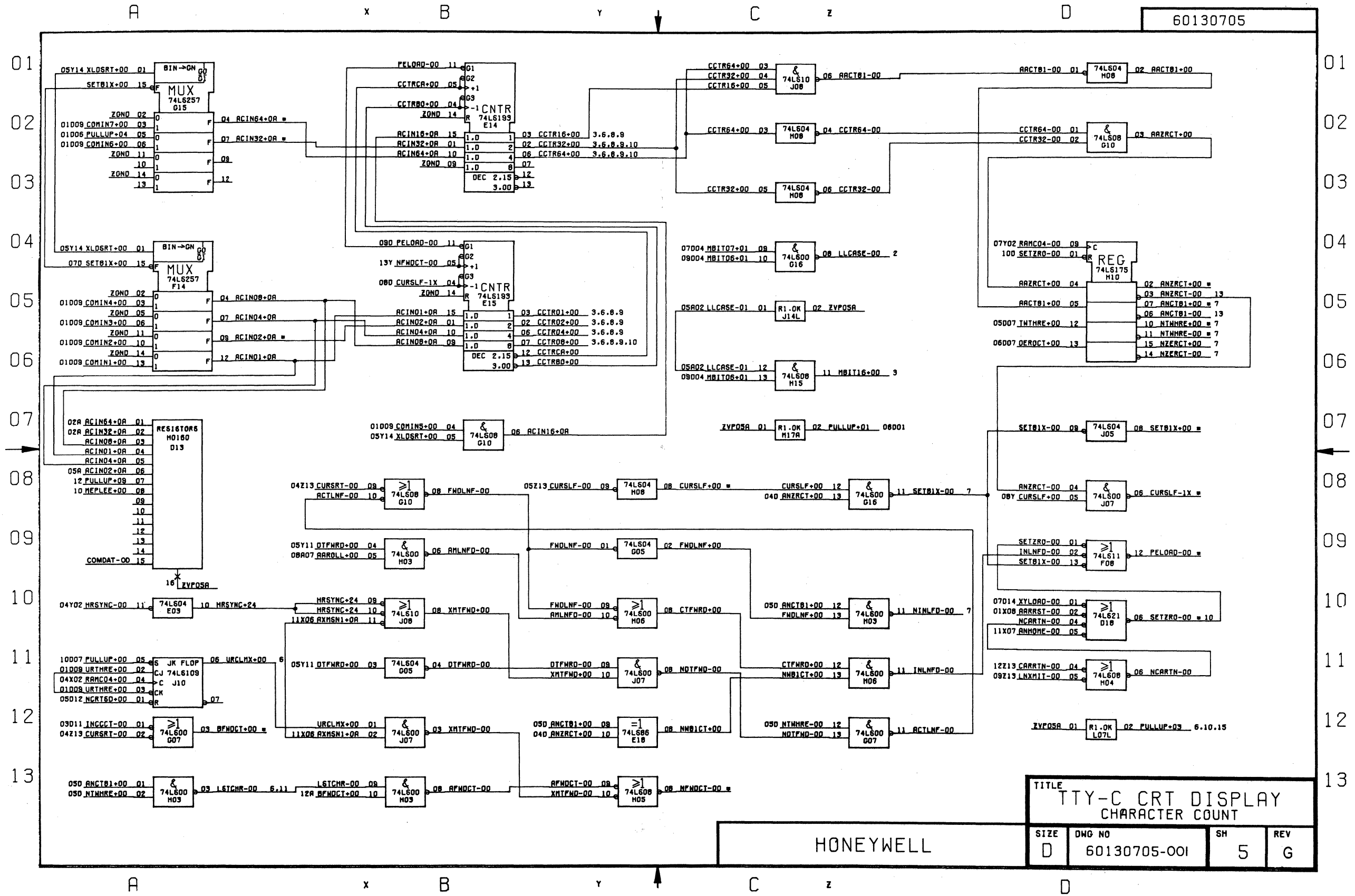

|   |                        |         |          |
|---|------------------------|---------|----------|
| TITLE<br>TTY-C CRT DISPLAY<br>CHARACTER COUNT |                        |         |          |
| SIZE<br>D                                     | DWG NO<br>60130705-001 | SH<br>5 | REV<br>G |

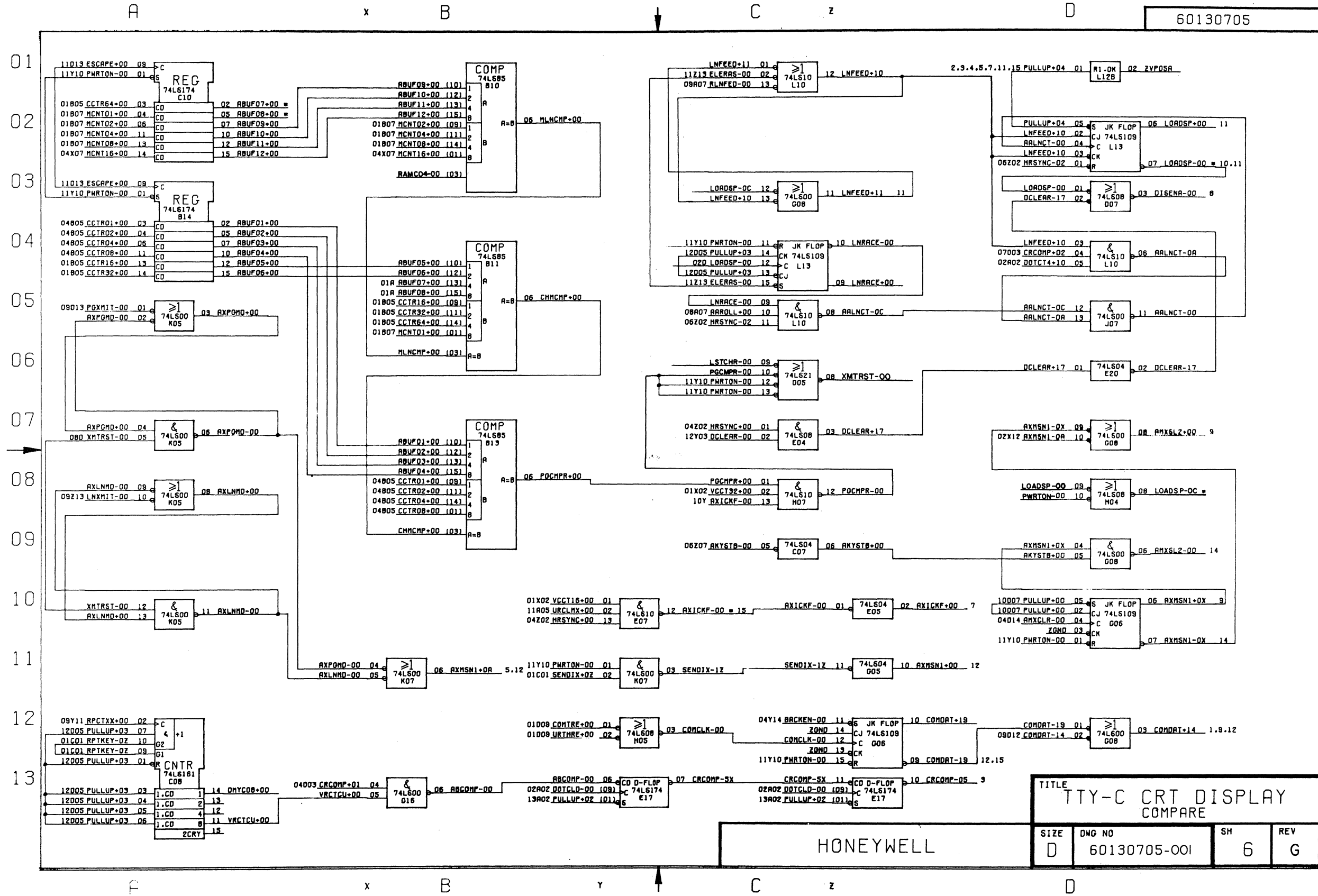

|                                       |              |    |     |
|---------------------------------------|--------------|----|-----|
| TITLE<br>TTY-C CRT DISPLAY<br>COMPARE |              |    |     |
| SIZE                                  | DWG NO       | SH | REV |
| D                                     | 60130705-001 | 6  | G   |

HONEYWELL

60130705

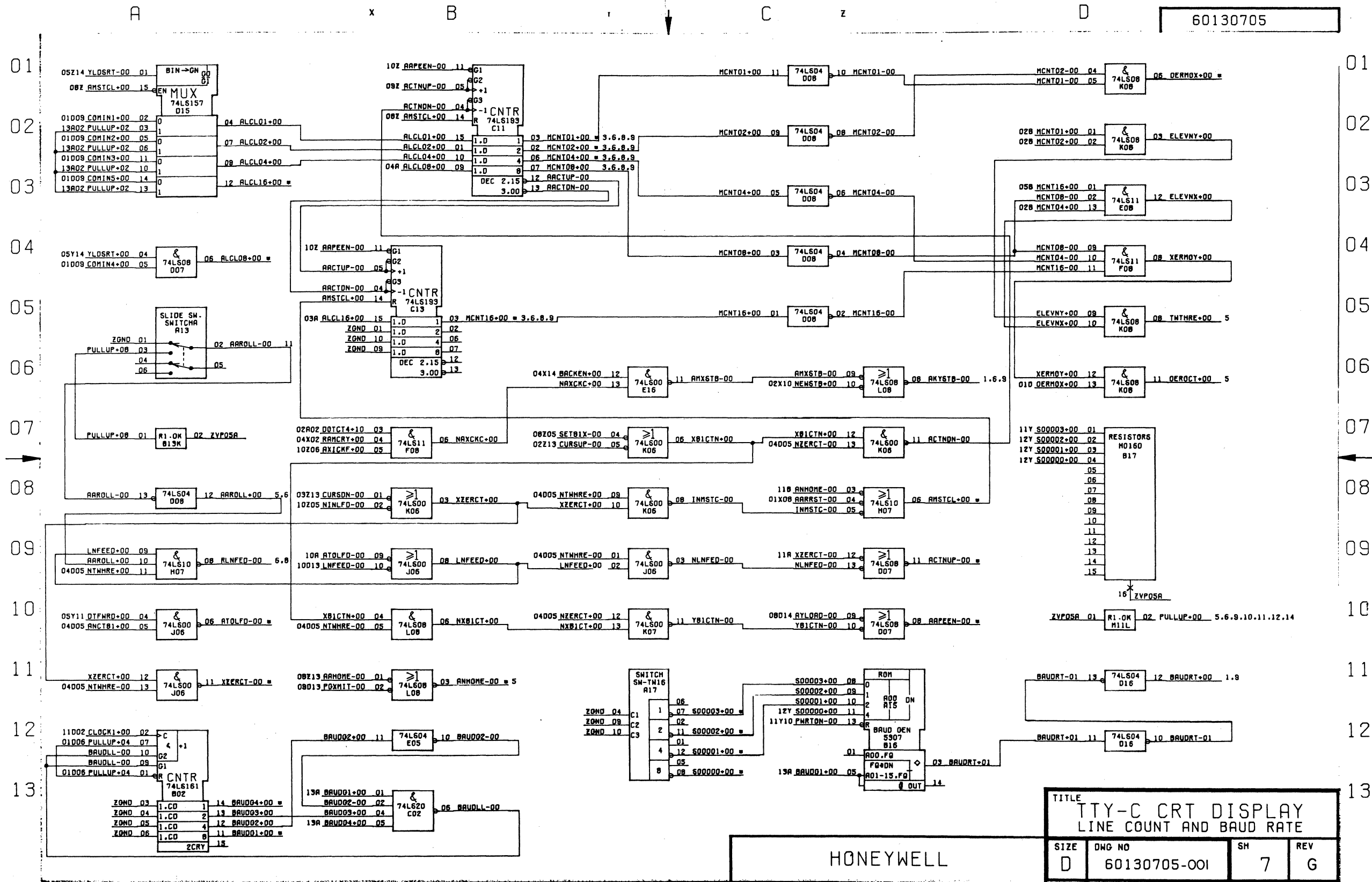

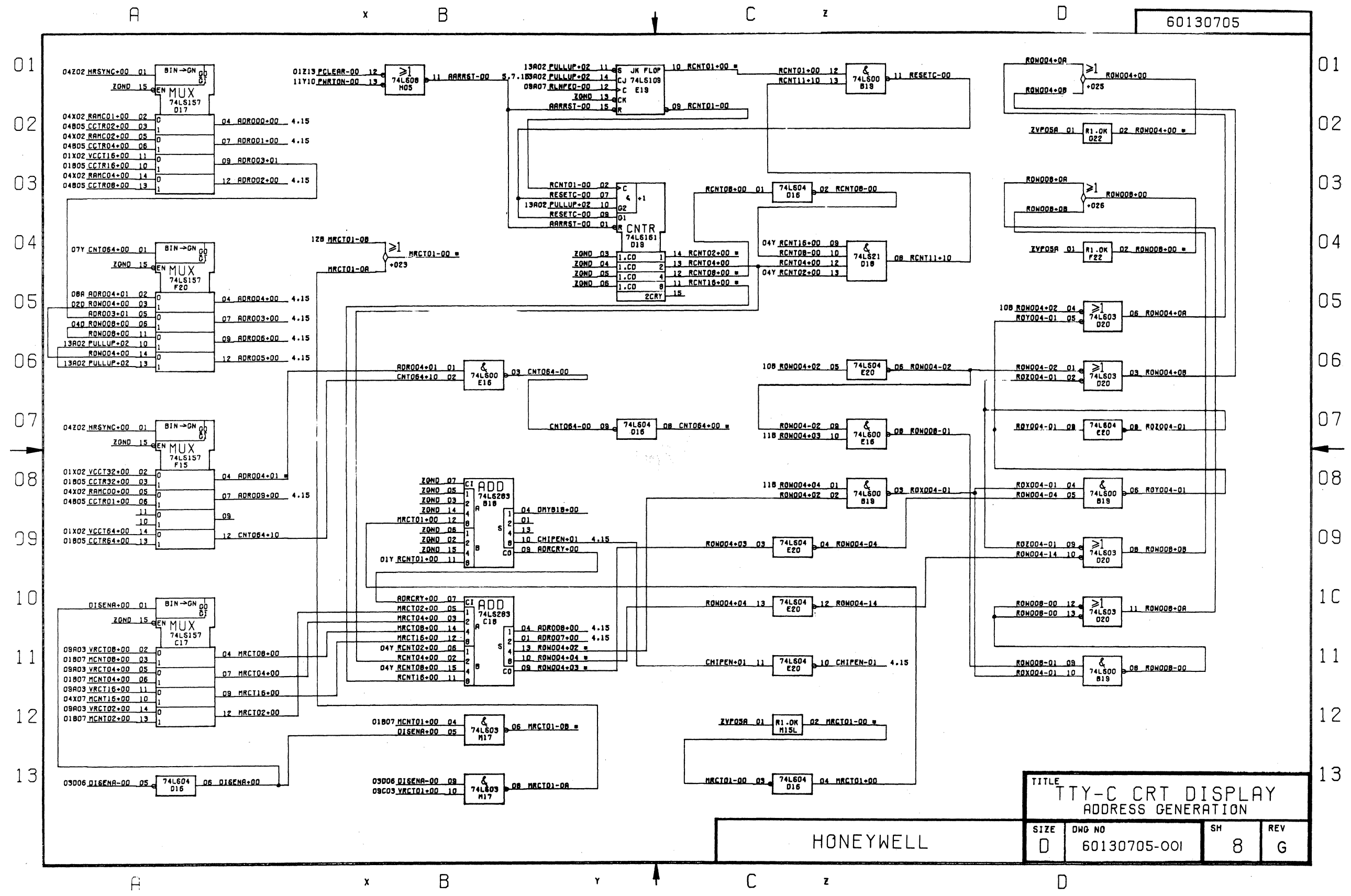

60130705

TITLE  
TTY-C CRT DISPLAY  
ADDRESS GENERATION

|      |              |    |     |
|------|--------------|----|-----|
| SIZE | DWG NO       | SH | REV |
| D    | 60130705-001 | 8  | G   |

HONEYWELL



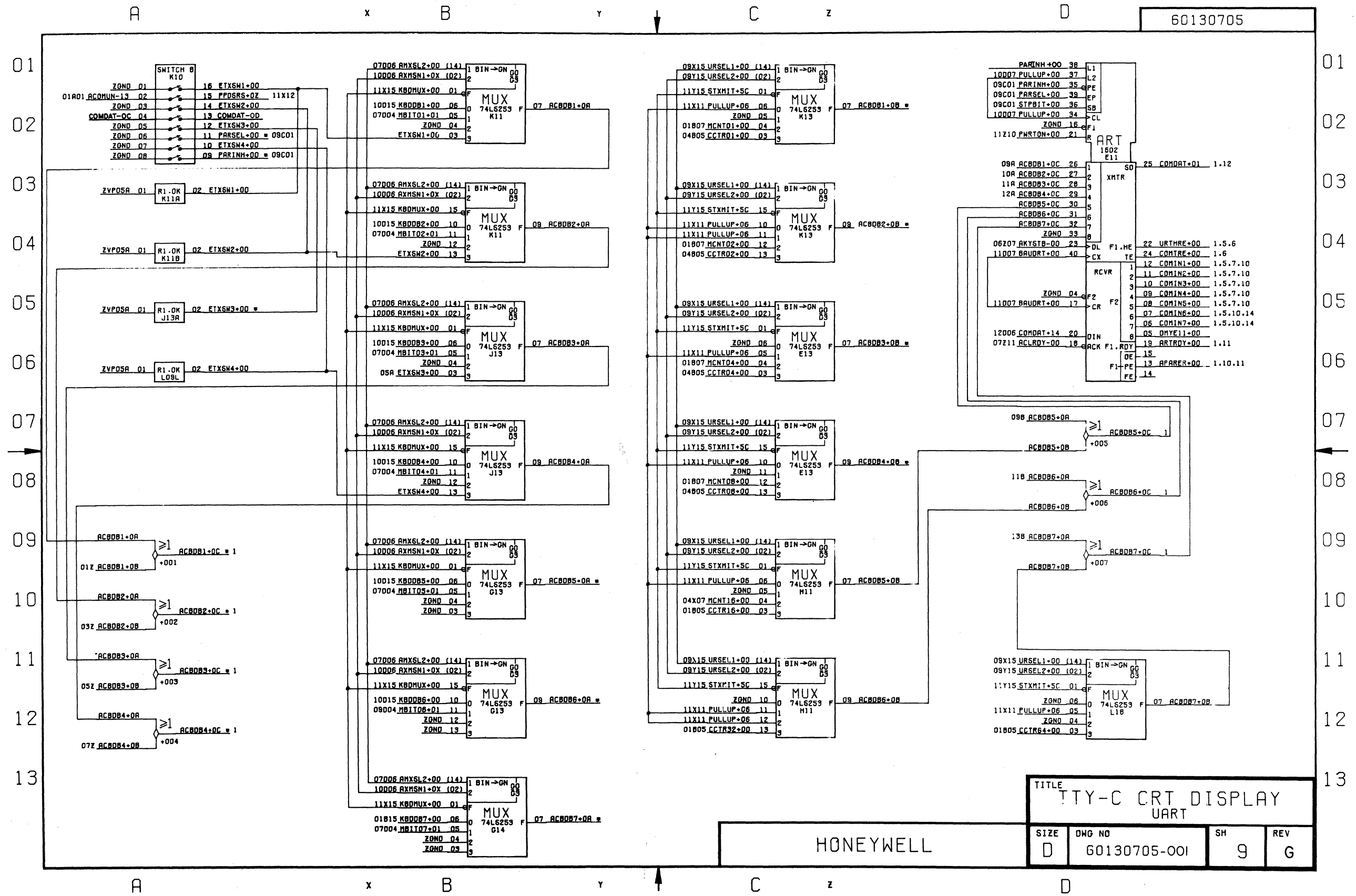

60130705

TITLE  
TTY-C CRT DISPLAY  
UART

|           |                        |         |          |
|-----------|------------------------|---------|----------|
| SIZE<br>D | DWG NO<br>60130705-001 | SH<br>9 | REV<br>G |
|-----------|------------------------|---------|----------|

HONEYWELL

60130705

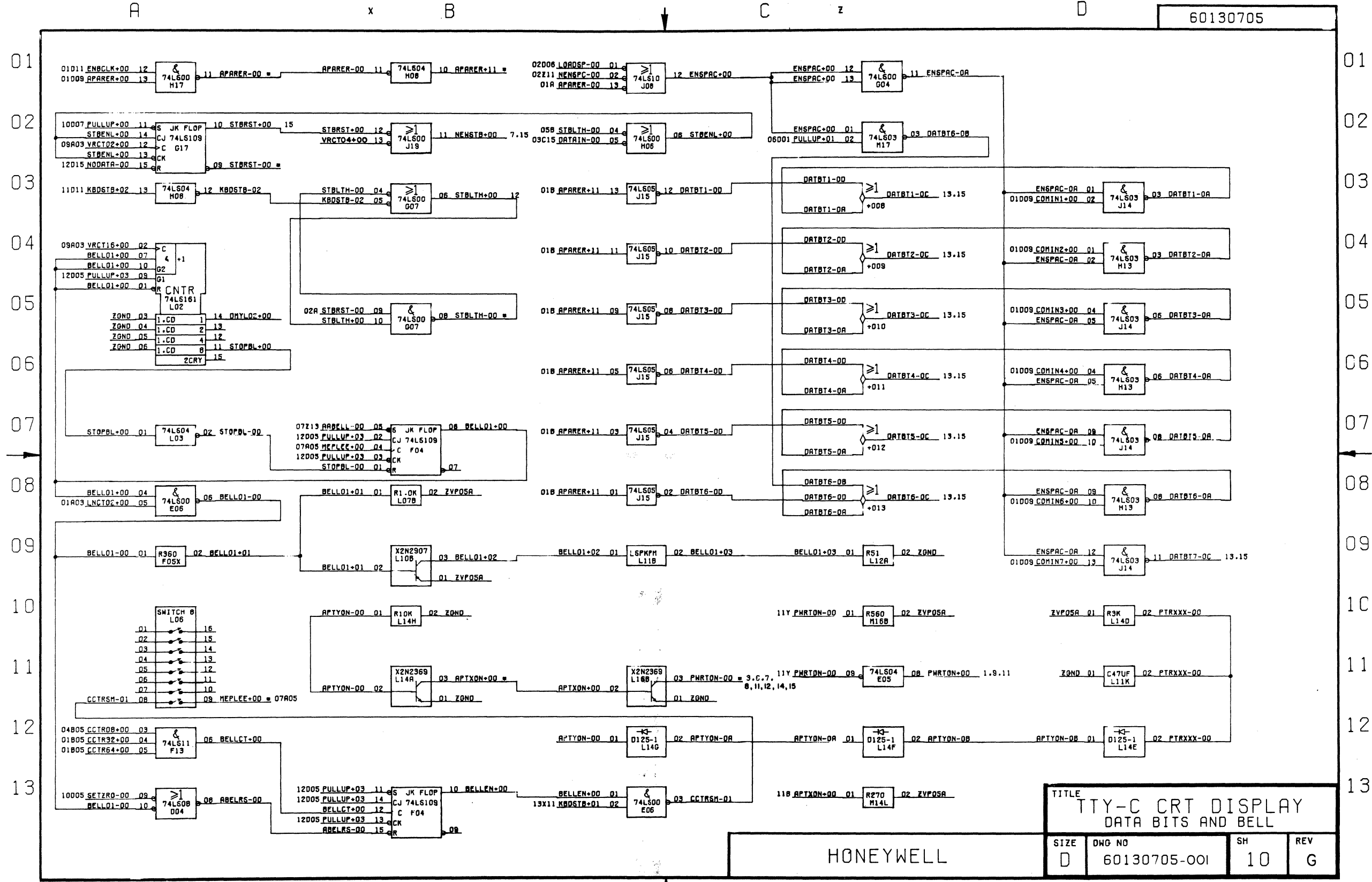

TITLE  
TTY-C CRT DISPLAY  
DATA BITS AND BELL

|      |              |    |     |
|------|--------------|----|-----|
| SIZE | DWG NO       | SH | REV |
| D    | 60130705-001 | 10 | G   |

HONEYWELL

60130705

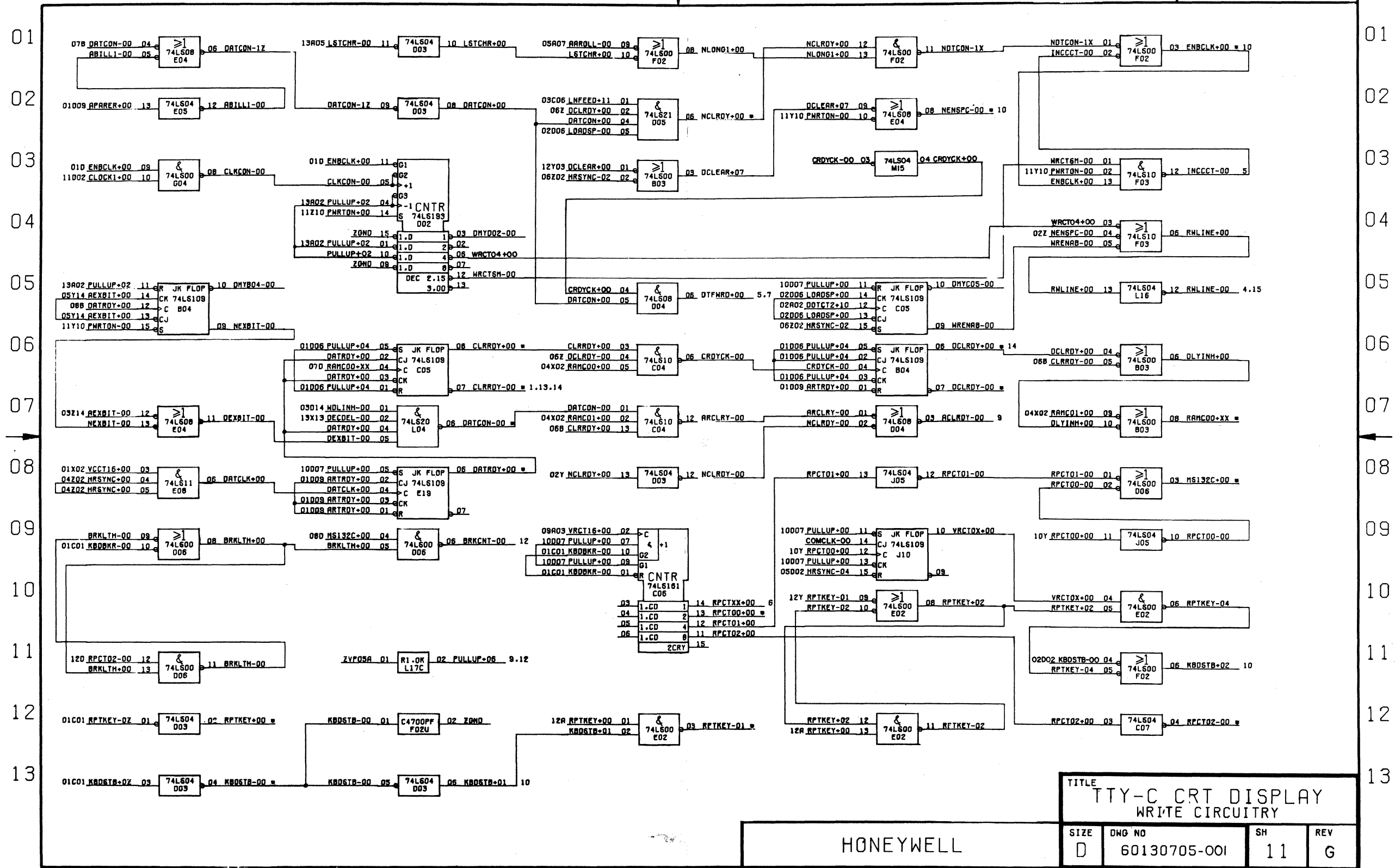

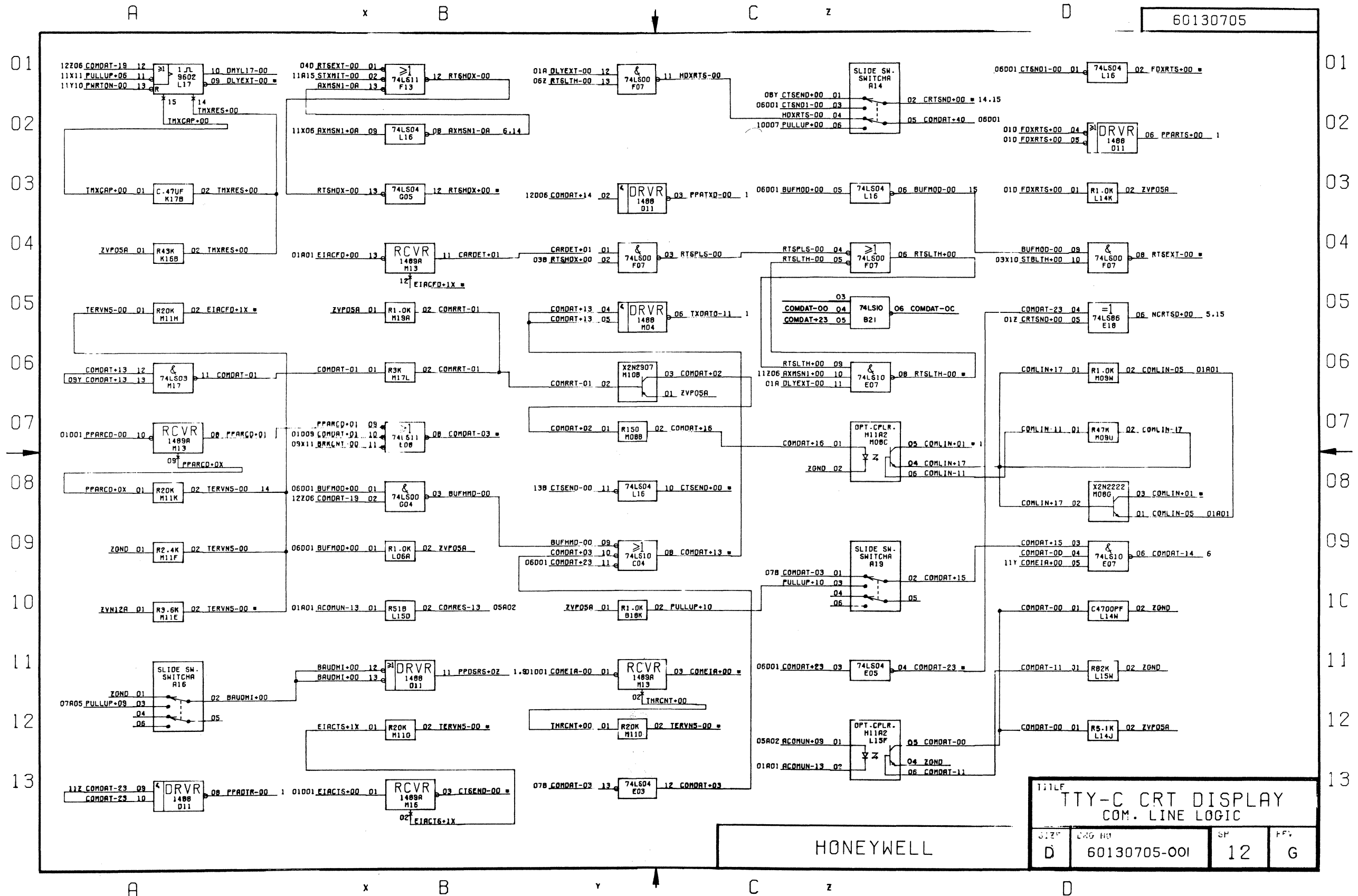

60130705

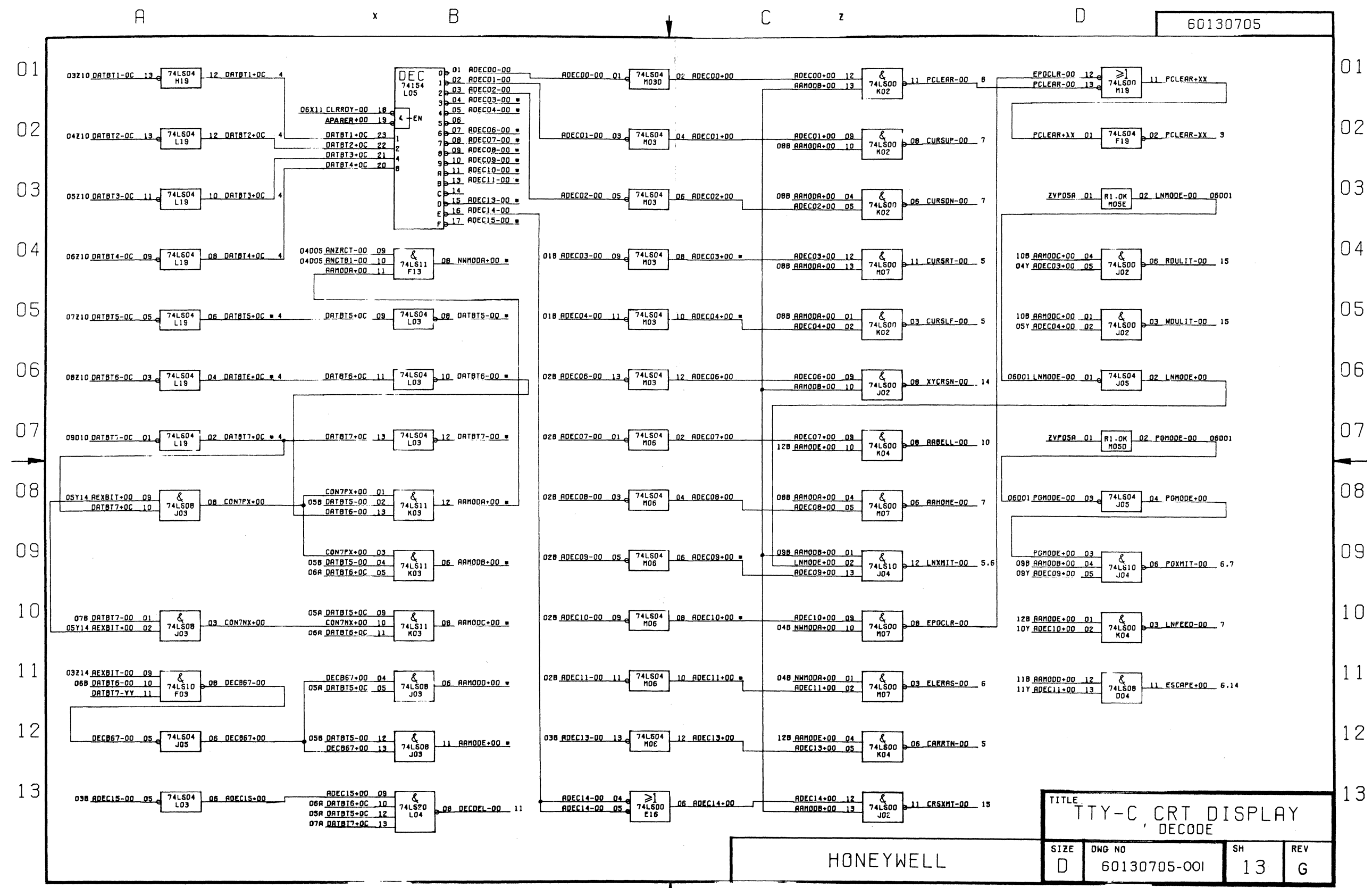

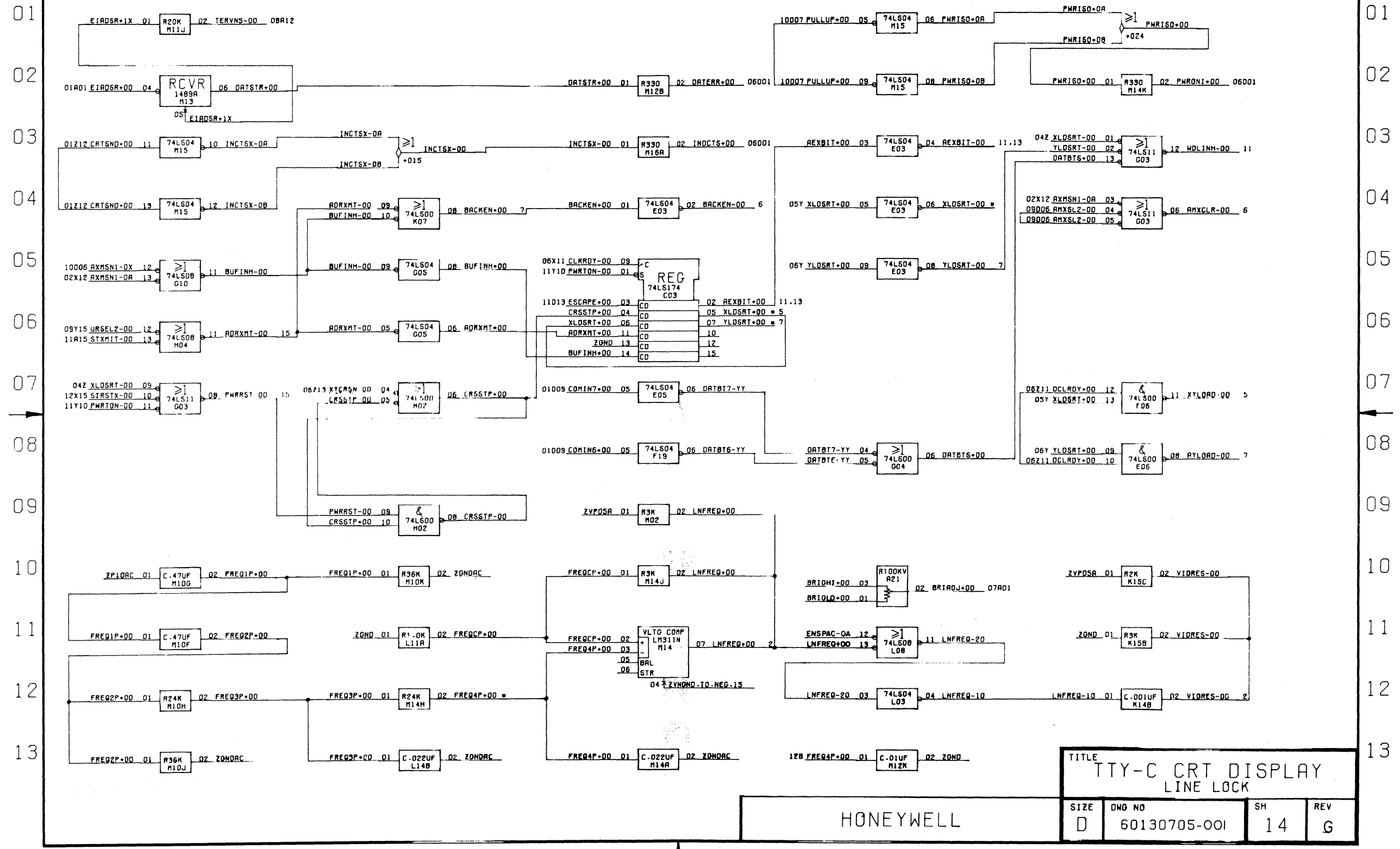

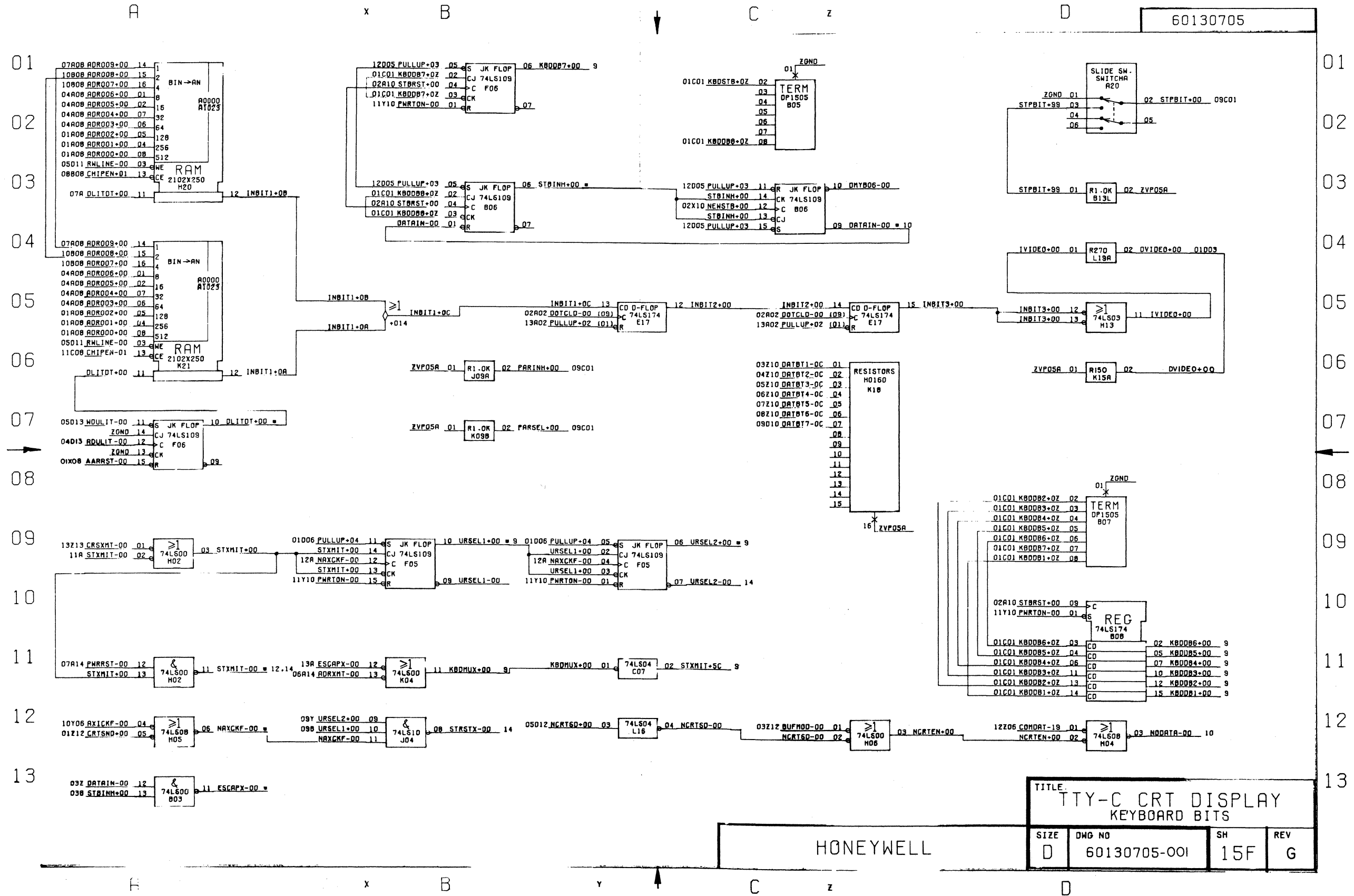

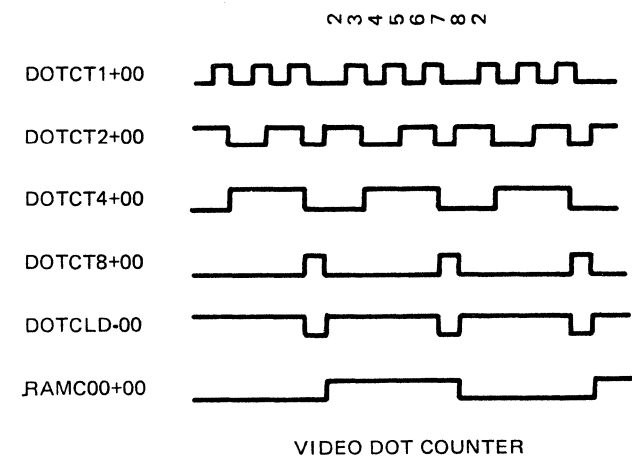
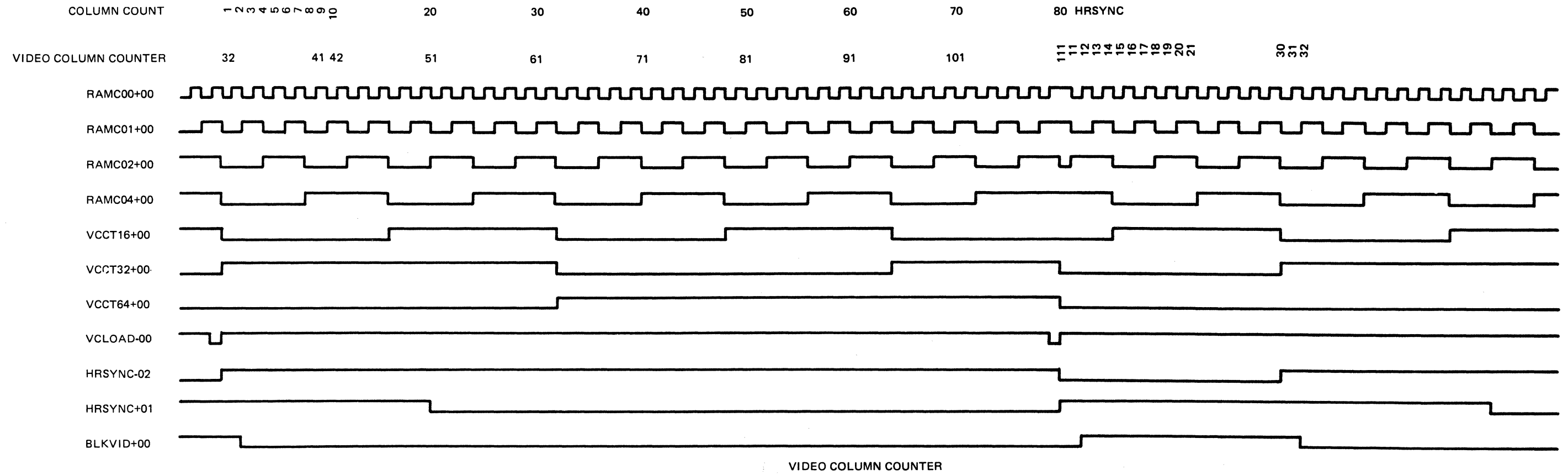



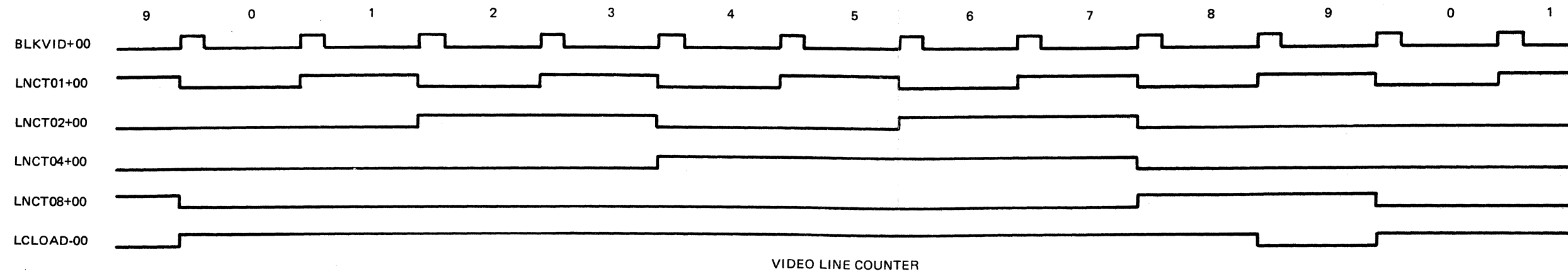

VIDEO LINE COUNTER

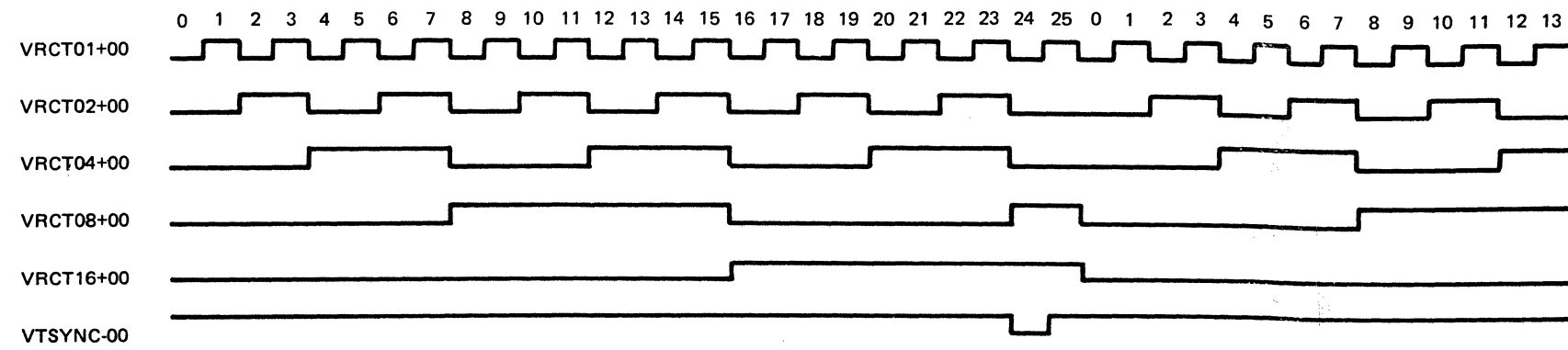
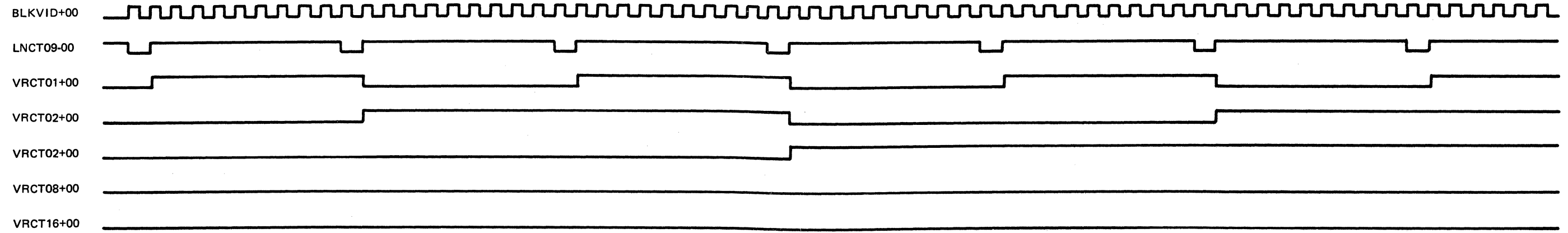

VIDEO ROW COUNTER

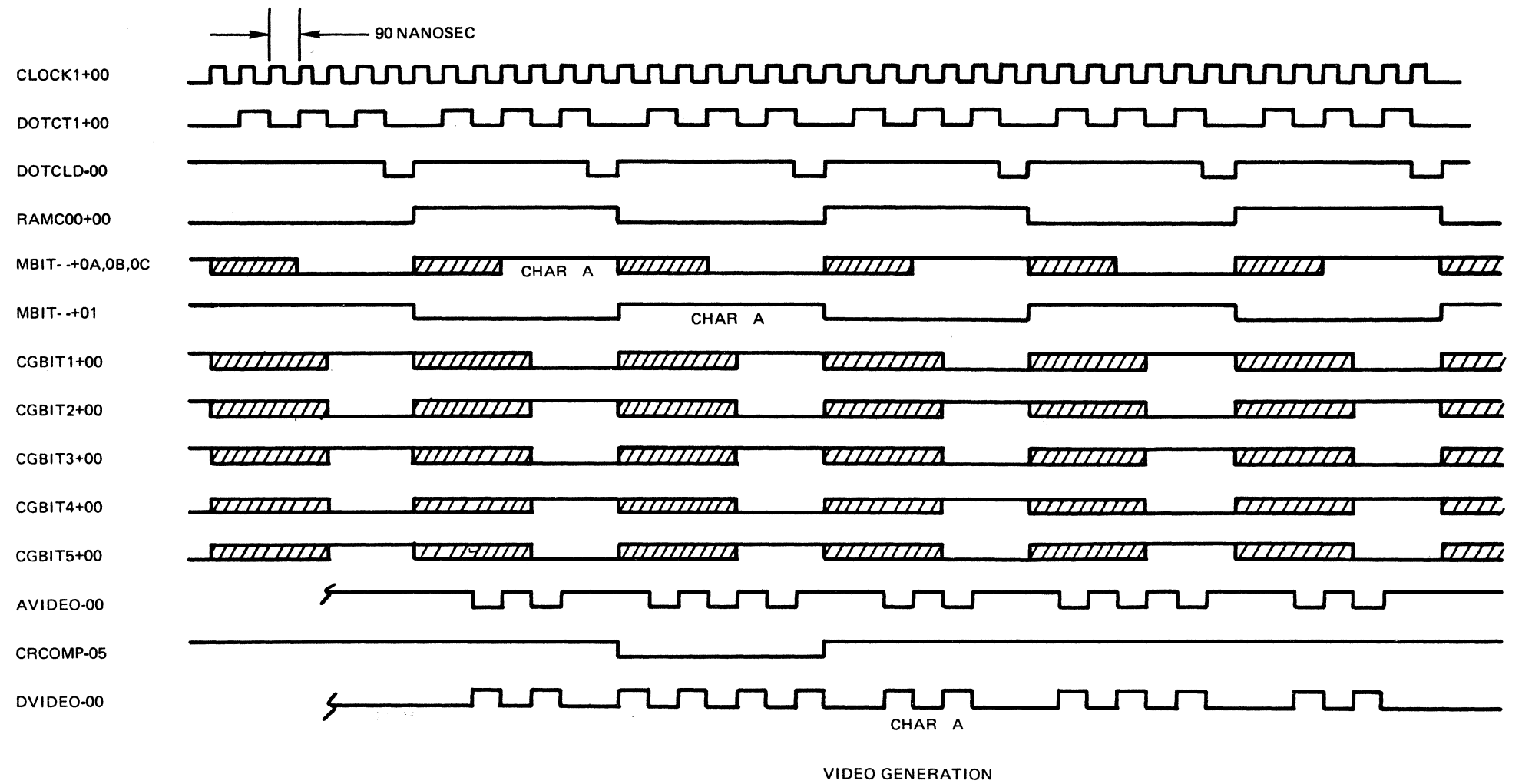

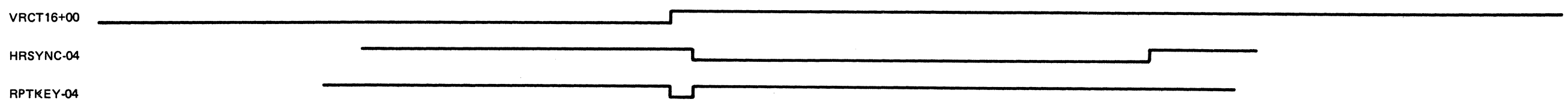
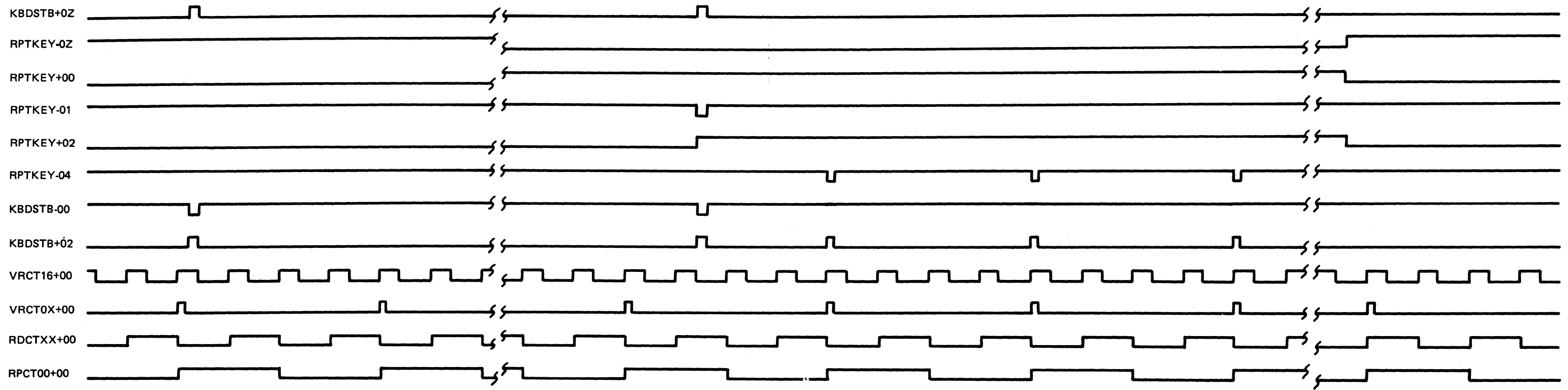

REPEAT TIMING

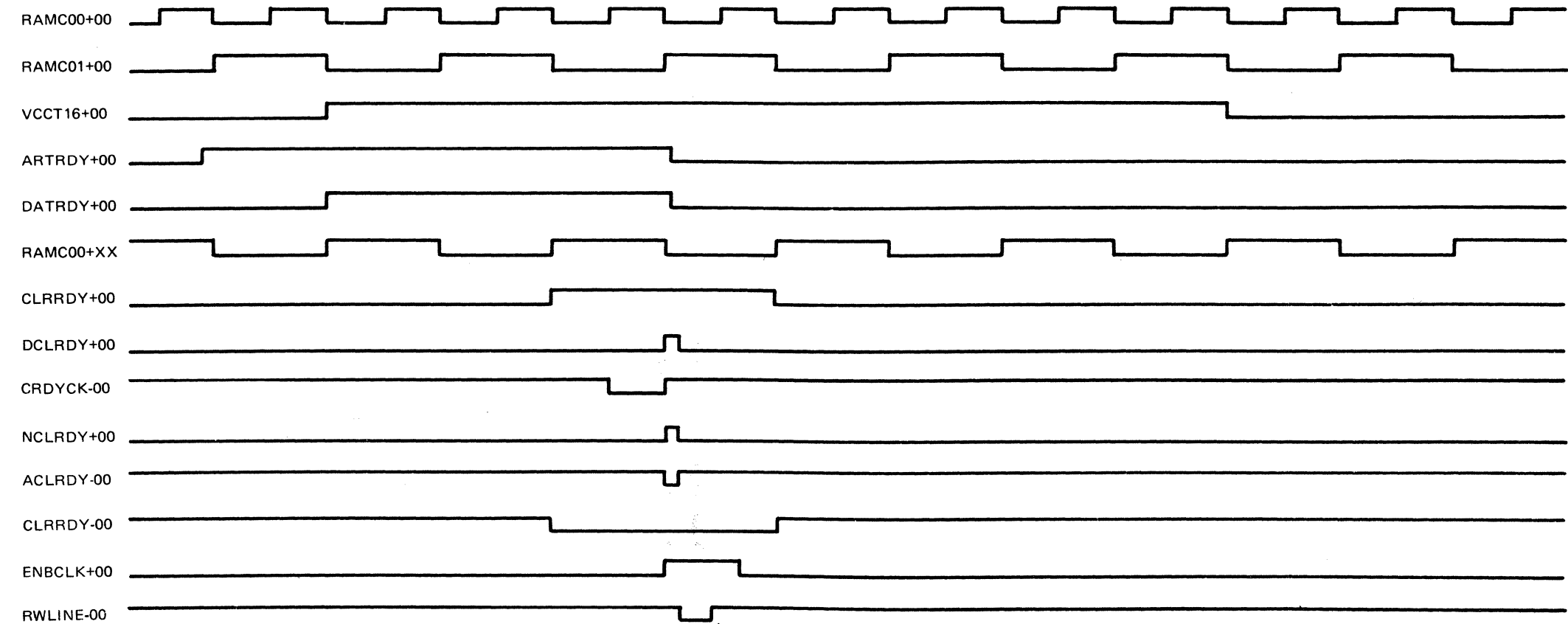
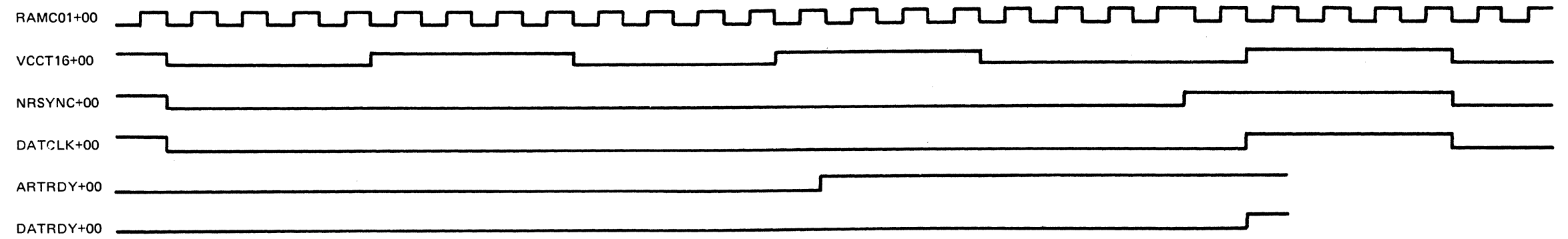

NORMAL WRITE SEQUENCE

HONEYWELL PROPRIETARY AND CONFIDENTIAL

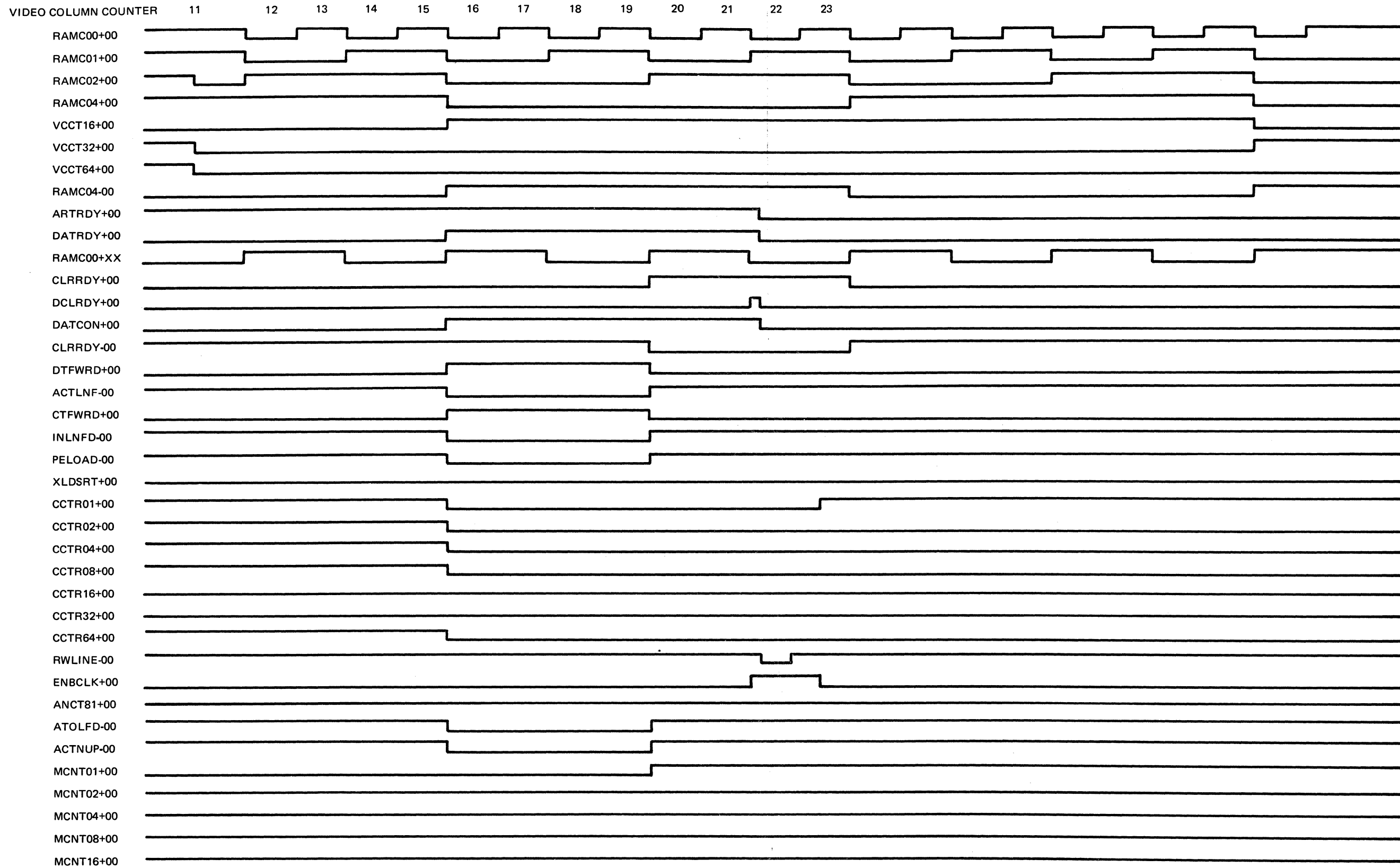

CURSOR WRAP WITH DATA

Timing Diagrams (Sheet 6 of 6)

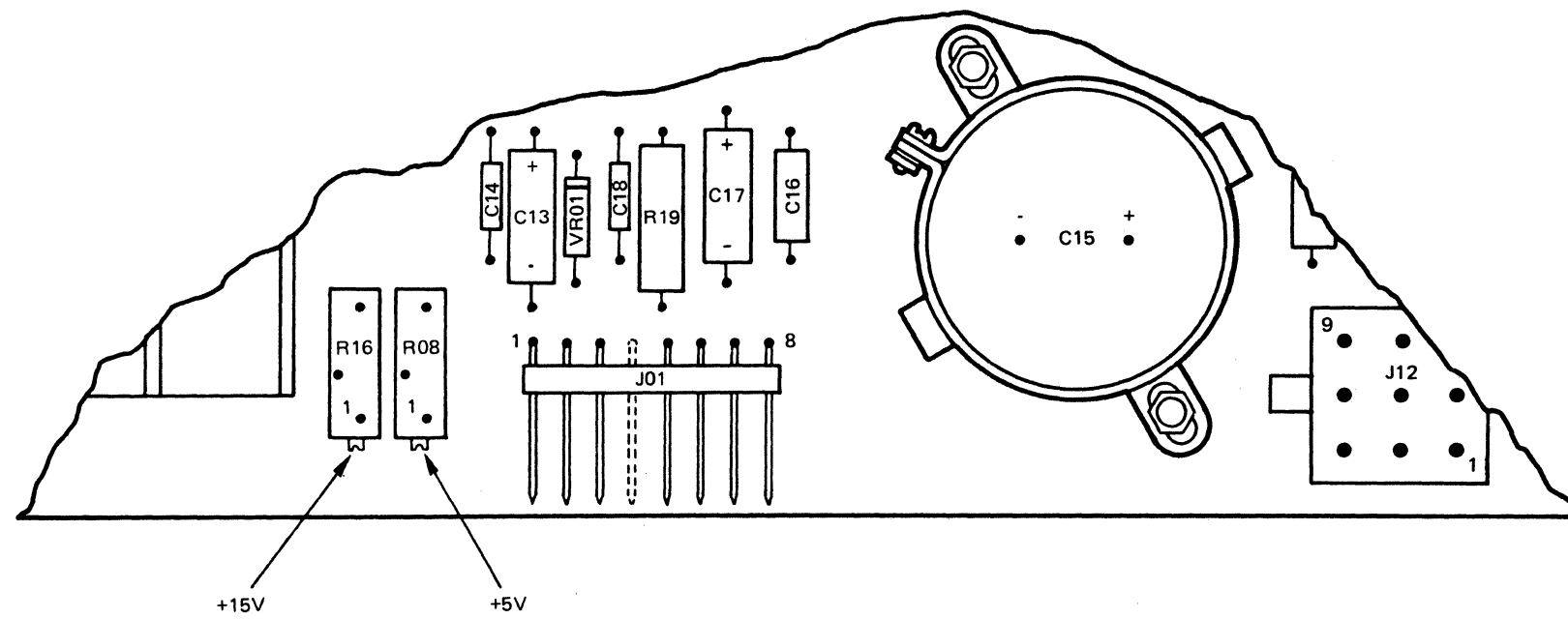

1. Remove the cover from the terminal.
2. Turn the terminal on.
3. Adjust the +5 volts as follows:
  - a. Using a dc voltmeter, measure the voltage between pin 3 (+5V) and pin 8 (ground) at connector J01 of BP2TYC PWA.
  - b. Adjust R08 on the power supply PWA for a nominal reading of +5 volts.
4. Adjust the +15 volts as follows:
  - a. Using a dc voltmeter, measure the voltage between pin 5 (+15V) and pin 2 (ground) at connector J01 of BP2TYC PWA.
  - b. Adjust R16 on the power supply PWA for a nominal reading of +15 volts.
5. Turn off the power and replace the cover.

NOTE

PWA component locations are shown in Section X of this manual. The power supply schematic is provided elsewhere in this section.

WAVEFORMS

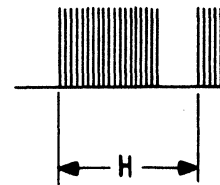

Q101-B  
2.5V P-P

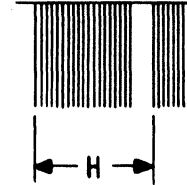

VI-CATHODE  
20V P-P

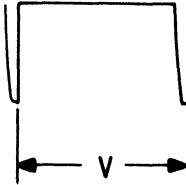

CR101-ANODE  
3V P-P

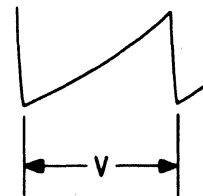

Q103-B  
4.5V P-P

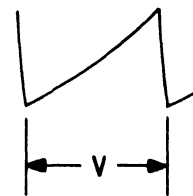

Q104-B  
1.2V P-P

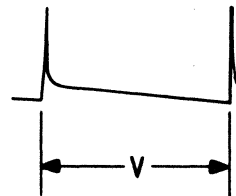

Q104-C  
45V P-P

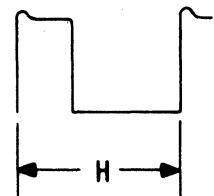

Q105-B  
3V P-P

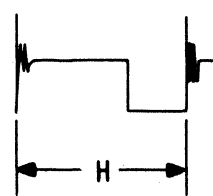

Q105-C  
30V P-P

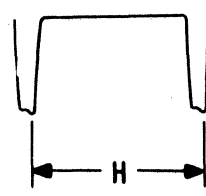

Q106-C  
170V P-P

CRT CIRCUIT BOARD

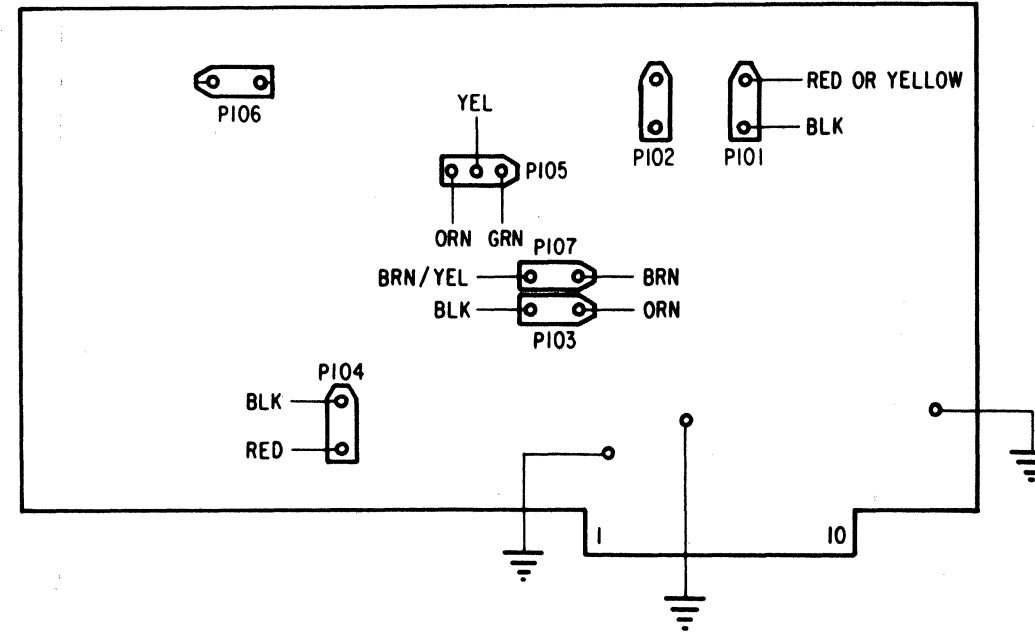

TROUBLESHOOTING GUIDE

| SYMPTOM                       | POSSIBLE REMEDY  |
|-------------------------------|--|
| Screen is dark                | Check "A" bus Q106, Q105, CR2  |
| Loss of video                 | CR105, Q101  |
| Power consumption is too high | Check horizontal drive waveform; check proper placement of horizontal linearity sleeve; Q105, Q106 |

A schematic diagram is given in Figure 6-4. Circuit board component locations are given in Figure 8-2.

CRT Display Specifications

1. Using keytop puller (part number SW-10485), remove the button from the module being replaced and as many adjacent buttons as required to furnish adequate work space. The buttons can be removed by pulling upward or by prying upward, with a padded tool, from their under surface.

**CAUTION**

Remove buttons from alternate action modules only when they are in the free position. Failure to do this will result in damage to the module.



2. Unsolder the four terminals of the lead frame package from the termination board, using a 750° F controlled temperature iron. When unsoldering the terminals, use a solder removal tool to remove all solder from the pin holes in the printed circuit board.

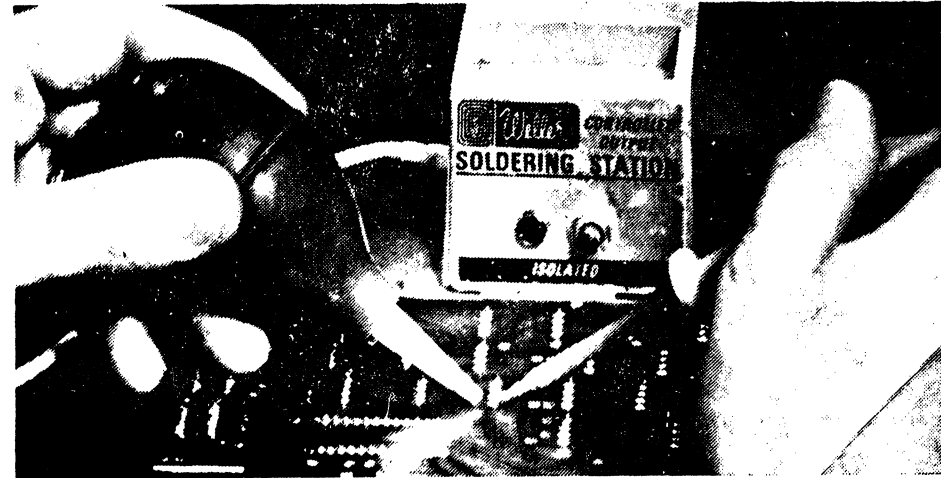

3. Insert module removal tools (part number SD-10101) at each end of the module.

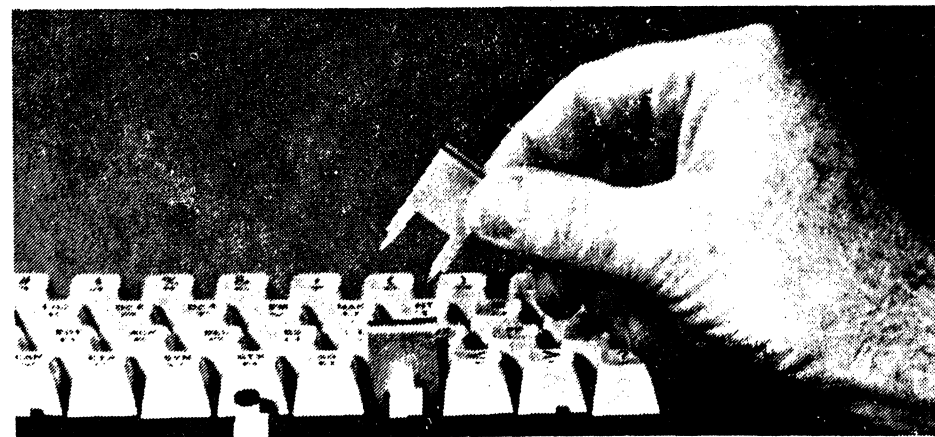

4. With the module removal tools in position, grip the switch module with a pair of pliers and pull straight out.

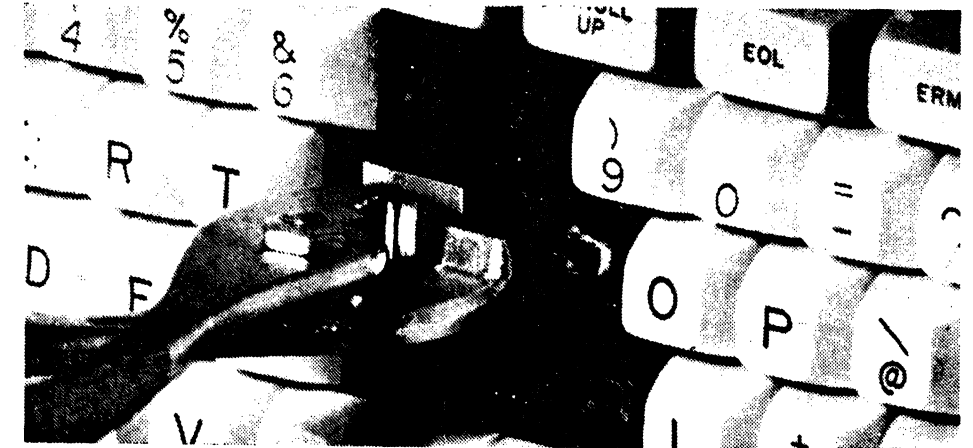

5. Replace with new module. Take care to orient switch properly and observe that solder terminals are through the printed circuit board prior to snapping in place.
6. Solder the new switch terminals using 60/40 rosin core solder employing a 750° F controlled temperature 1/8-inch chisel tip soldering iron.

**CAUTION**

The solder tip should never be held on the terminal for over 4 seconds.

7. The solder connections may be cleaned with a mild solvent. However, take care not to contact the switch with the solvent.
8. Reassemble the buttons on the switch modules. When work has been completed, perform a visual check to see that the correct buttons are returned to the correct modules.



OUTPUT PIN ASSIGNMENTS

Pin numbers are referenced to a 3M connector, part number 3462-0000.

| PIN NUMBER | OUTPUT SIGNAL               |
|------------|-----------------------------|
| 1          | +5 Vdc                      |
| 3          | +5 Vdc                      |
| 5          | +5 Vdc                      |
| 7          | Ground                      |
| 9          | Ground                      |
| 11         | Ground                      |
| 13         | Bit 2                       |
| 15         | Bit 1                       |
| 17         | Bit 3                       |
| 19         | Bit 4                       |
| 21         | Bit 5                       |
| 23         | Bit 6                       |
| 25         | Bit 7                       |
| 2          | +5 Vdc                      |
| 4          | +5 Vdc                      |
| 6          | +5 Vdc                      |
| 8          | Ground                      |
| 10         | Ground                      |
| 12         | Ground                      |
| 14         | -12 Vdc                     |
| 16         | Repeat                      |
| 18         | Function key at position 28 |
| 20         | Strobe                      |
| 22         | Function key at position 33 |
| 24         | Break                       |
| 26         | Bit 8                       |

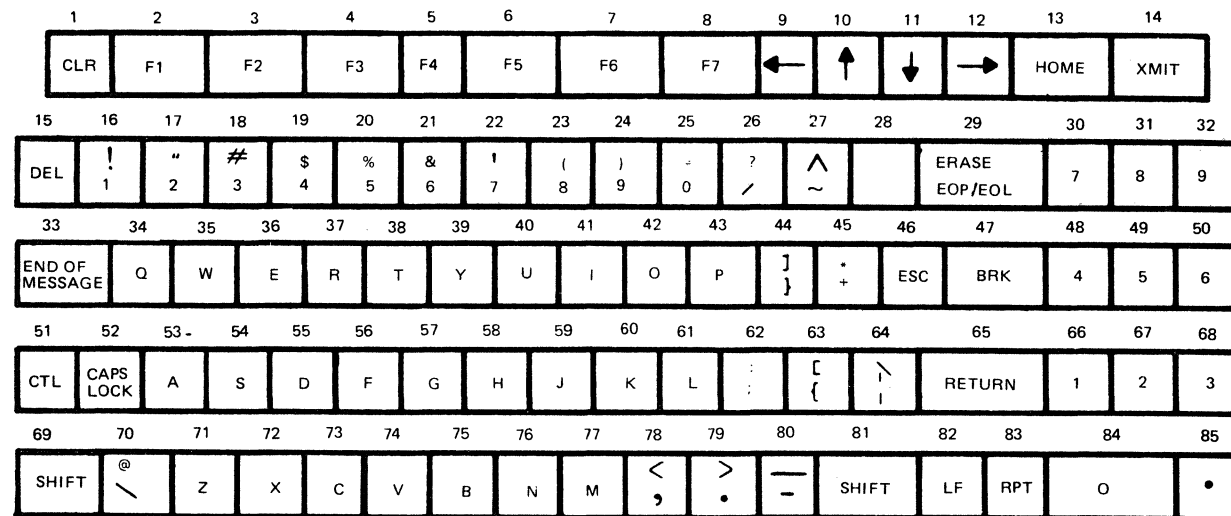

| KEY NUMBER | UNSHIFTED 8765 4321 | SHIFTED 8765 4321 | CONTROL 8765 4321 | CAPS LOCK 8765 4321 | KEY NUMBER | UNSHIFTED 8765 4321 | SHIFTED 8765 4321 | CONTROL 8765 4321 | CAPS LOCK 8765 4321 |
|------------|---------------------|-------------------|-------------------|---------------------|------------|---------------------|-------------------|-------------------|---------------------|
| 1          | 1110 0000           | 1110 0000         |                   | 1110 0000           | 44         | 0111 1101           | 0101 1101         | 0001 1101         | 0101 1101           |
| 2          | 1011 0000           | 1011 0001         |                   | 1011 0000           | 45         | 0010 1011           | 0010 1010         |                   | 0010 1011           |
| 3          | 1011 0010           | 1011 0101         |                   | 1011 0010           | 46         | 0001 1011           | 0001 1011         | 0001 1011         | 0001 1011           |
| 4          | 1011 0110           | 1011 0111         |                   | 1011 0110           | 47         |                     |                   |                   |                     |
| 5          | 1011 1000           | 1011 1001         |                   | 1011 1000           | 48         | 0011 0100           | 0011 0100         | 0011 0100         | 0011 0100           |
| 6          | 1011 1010           | 1011 1011         |                   | 1011 1010           | 49         | 0011 0101           | 0011 0101         | 0011 0101         | 0011 0101           |
| 7          | 1011 1100           | 1011 1101         |                   | 1011 1100           | 50         | 0011 0110           | 0011 0110         | 0011 0110         | 0011 0110           |
| 8          | 1011 1110           | 1011 1111         |                   | 1011 1110           | 51         |                     |                   |                   |                     |
| 9          | 1100 0100           | 1100 0100         | 1100 0100         | 1100 0100           | 52         |                     |                   |                   |                     |
| 10         | 1100 0001           | 1100 0001         | 1100 0001         | 1100 0001           | 53         | 0110 0001           | 0100 0001         | 0000 0001         | 0100 0001           |
| 11         | 1100 0010           | 1100 0010         | 1100 0010         | 1100 0010           | 54         | 0111 0011           | 0101 0011         | 0001 0011         | 0101 0011           |
| 12         | 1100 0011           | 1100 0011         | 1100 0011         | 1100 0011           | 55         | 0110 0100           | 0100 0100         | 0000 0100         | 0100 0100           |
| 13         | 1100 1000           | 1100 1000         | 1100 1000         | 1100 1000           | 56         | 0110 0110           | 0100 0110         | 0000 0110         | 0100 0110           |
| 14         | 1110 1001           | 1110 1001         | 1110 1001         | 1110 1001           | 57         | 0110 0111           | 0100 0111         | 0000 0111         | 0100 0111           |
| 15         | 0111 1111           | 0111 1111         | 0111 1111         | 0111 1111           | 58         | 0110 1000           | 0100 1000         | 0000 1000         | 0100 1000           |
| 16         | 0011 0001           | 0010 0001         |                   | 0011 0001           | 59         | 0110 1010           | 0100 1010         | 0000 1010         | 0100 1010           |
| 17         | 0011 0010           | 0010 0010         |                   | 0011 0010           | 60         | 0110 1011           | 0100 1011         | 0000 1011         | 0100 1011           |
| 18         | 0011 0011           | 0010 0011         |                   | 0011 0011           | 61         | 0110 1100           | 0100 1100         | 0000 1100         | 0100 1100           |
| 19         | 0011 0100           | 0010 0100         |                   | 0011 0100           | 62         | 0011 1011           | 0011 1010         |                   | 0011 1011           |
| 20         | 0011 0101           | 0010 0101         |                   | 0011 0101           | 63         | 0111 1011           | 0101 1011         | 0001 1011         | 0101 1011           |
| 21         | 0011 0110           | 0010 0110         |                   | 0011 0110           | 64         | 0111 1100           | 0101 1100         | 0001 1100         | 0101 1100           |
| 22         | 0011 0111           | 0010 0111         |                   | 0011 0111           | 65         | 0000 1101           | 0000 1101         | 0000 1101         | 0000 1101           |
| 23         | 0011 1000           | 0010 1000         |                   | 0011 1000           | 66         | 0011 0001           | 0011 0001         | 0011 0001         | 0011 0001           |
| 24         | 0011 1001           | 0010 1001         |                   | 0011 1001           | 67         | 0011 0010           | 0011 0010         | 0011 0010         | 0011 0010           |
| 25         | 0011 0000           | 0011 1101         |                   | 0011 0000           | 68         | 0011 0011           | 0011 0011         | 0011 0011         | 0011 0011           |
| 26         | 0010 1111           | 0011 1111         |                   | 0010 1111           | 69         |                     |                   |                   |                     |
| 27         | 0111 1110           | 0101 1110         | 0001 1110         | 0101 1110           | 70         | 0010 0000           | 0100 0000         | 0000 0000         | 0100 0000           |
| 28         |                     |                   |                   |                     | 71         | 0111 1010           | 0101 1010         | 0001 1010         | 0101 1010           |
| 29         | 1100 1011           | 1100 1010         |                   | 1100 1011           | 72         | 0111 1000           | 0101 1000         | 0001 1000         | 0101 1000           |
| 30         | 0011 0111           | 0011 0111         | 0011 0111         | 0011 0111           | 73         | 0110 0011           | 0100 0011         | 0000 0011         | 0100 0011           |
| 31         | 0011 1000           | 0011 1000         | 0011 1000         | 0011 1000           | 74         | 0111 0110           | 0101 0110         | 0001 0110         | 0101 0110           |
| 32         | 0011 1001           | 0011 1001         | 0011 1001         | 0011 1001           | 75         | 0110 0010           | 0100 0010         | 0000 0010         | 0100 0010           |
| 33         |                     |                   |                   |                     | 76         | 0110 1110           | 0100 1110         | 0000 1110         | 0100 1110           |
| 34         | 0111 0001           | 0101 0001         | 0001 0001         | 0101 0001           | 77         | 0110 1101           | 0100 1101         | 0000 1101         | 0100 1101           |
| 35         | 0111 0111           | 0101 0111         | 0001 0111         | 0101 0111           | 78         | 0010 1100           | 0011 1100         |                   | 0010 1100           |
| 36         | 0110 0101           | 0100 0101         | 0000 0101         | 0100 0101           | 79         | 0010 1110           | 0011 1110         |                   | 0010 1110           |
| 37         | 0111 0010           | 0101 0010         | 0001 0010         | 0101 0010           | 80         | 0010 1101           | 0101 1111         | 0001 1111         | 0010 1101           |
| 38         | 0111 0100           | 0101 0100         | 0001 0100         | 0101 0100           | 81         |                     |                   |                   |                     |
| 39         | 0111 1001           | 0101 1001         | 0001 1001         | 0101 1001           | 82         | 0000 1010           | 0000 1010         | 0000 1010         | 0000 1010           |
| 40         | 0111 0101           | 0101 0101         | 0001 0101         | 0101 0101           | 83         |                     |                   |                   |                     |
| 41         | 0110 1001           | 0100 1001         | 0000 1001         | 0100 1001           | 84         | 0011 0000           | 0011 0000         | 0011 0000         | 0011 0000           |
| 42         | 0110 1111           | 0100 1111         | 0000 1111         | 0100 1111           | 85         | 0010 1110           | 0010 1110         | 0010 1110         | 0010 1110           |
| 43         | 0111 0000           | 0101 0000         | 0001 0000         | 0101 0000           | 86         | 0010 0000           | 0010 0000         | 0010 0000         | 0010 0000           |

Keyboard Output Codes

HONEYWELL PROPRIETARY AND CONFIDENTIAL

LOGIC BLOCK DIAGRAM GLOSSARY/INDEX  
TTY-C CRT DISPLAY

DOCUMENT NO. REV.  
GLB60130734-001 B

BOARD NAME ASSEMBLY DOC. NO.  
BE2TCY 60130730

PAGE 1 OF 5  
EDITED 08/17/77

| PAGE | TITLE                      |
|------|----------------------------|
| 1    | CONNECTORS                 |
| 2    | CLOCK AND HORIZONTAL SYNC  |
| 3    | VIDEO AND COUNT GENERATION |
| 4    | MEMORY                     |
| 5    | CHARACTER COUNT            |
| 6    | COMPARE                    |
| 7    | LINE COUNT AND BAUD RATE   |
| 8    | ADDRESS GENERATION         |
| 9    | UART                       |
| 10   | DATA BITS AND BELL         |
| 11   | WRITE CIRCUITRY            |
| 12   | COM. LINE LOGIC            |
| 13   | DECODE                     |
| 14   | LINE LOCK                  |
| 15   | KEYBOARD BITS              |

HONEYWELL PROPRIETARY AND CONFIDENTIAL

LOGIC BLOCK DIAGRAM GLOSSARY/INDEX  
TTY-C CRT DISPLAY

DOCUMENT NO. REV.  
GLB60130734-001 B

BOARD NAME ASSEMBLY DOC. NO.  
BE2TCY 60130730

PAGE 2 OF 5  
EDITED 08/17/77

| SIGNAL NAME | ROW/COL /PAGE | N | SIGNAL NAME | ROW/COL /PAGE | N | SIGNAL NAME | ROW/COL /PAGE | N | SIGNAL NAME | ROW/COL /PAGE | N | SIGNAL NAME | ROW/COL /PAGE | N |
|-------------|---------------|---|-------------|---------------|---|-------------|---------------|---|-------------|---------------|---|-------------|---------------|---|
| OERMOX+00   | 01D07         | . | ACBDB2+0B   | 03C09         | . | ADEC04+00   | 05Y13         | . | ALCL02+00   | 01A07         | . | BAUDG1+00   | 12A07         | . |
| OEROCT+00   | 06D07         | . | ACBDB2+0C   | 10A09         | . | ADEC06+00   | 01X13         | . | ALCL04+00   | 01A07         | . | BAUDG2+00   | 12X07         | . |
| AABELL+00   | 07Z13         | . | ACBDB3+0A   | 05B09         | . | ADEC06+00   | 06Y13         | . | ALCL08+00   | 04A07         | . | BAUDG2+00   | 12A07         | . |
| AACT81-00   | 01C05         | . | ACBDB3+0B   | 05C09         | . | ADEC07+00   | 01X13         | . | ALCL16+00   | 01A07         | . | BAUDG3+00   | 12A07         | . |
| AACT81+00   | 01D05         | . | ACBDB3+0C   | 11A09         | . | ADEC07+00   | 07Y13         | . | AMLNFD+00   | 09X05         | . | BAUDG4+00   | 12A07         | . |
| AACTDN+00   | 01B07         | . | ACBDB4+0A   | 07B09         | . | ADEC08+00   | 01X13         | . | AMSTCL+00   | 08Z07         | . | BAUDHI+00   | 11A12         | . |
| AACTUP+00   | 01B07         | . | ACBDB4+0B   | 07C09         | . | ADEC08+00   | 08Y13         | . | AMXCLR+00   | 04D14         | . | BAUDLL+00   | 13X07         | . |
| AAHOME+00   | 08Z13         | . | ACBDB4+0C   | 12A09         | . | ADEC09+00   | 01X13         | . | AMXSL2+00   | 09D06         | . | BAUDRT+01   | 12D07         | . |
| AALNCT+00   | 05D06         | . | ACBDB5+0A   | 09B09         | . | ADEC09+00   | 09Y13         | . | AMXSL2+00   | 07D06         | . | BAUDRT+00   | 11D07         | . |
| AALNCT+0A   | 04D06         | . | ACBDB5+0B   | 09C09         | . | ADEC10+00   | 01X13         | . | AMXSTB+00   | 06Y07         | . | BAUDRT+01   | 11Z07         | . |
| AALNCT+0C   | 05C06         | . | ACBDB5+0C   | 07D09         | . | ADEC10+00   | 10Y13         | . | ANCT81+00   | 04D05         | . | BELLO1+00   | 08A10         | . |
| AAMODA+00   | 08X13         | . | ACBDB6+0A   | 11B09         | . | ADEC11+00   | 01X13         | . | ANCT81+00   | 04D05         | . | BELLO1+00   | 07X10         | . |
| AAMODB+00   | 09X13         | . | ACBDB6+0B   | 11C09         | . | ADEC11+00   | 11Y13         | . | ANHOME+00   | 11X07         | . | BELLO1+01   | 08X10         | . |
| AAMODC+00   | 10X13         | . | ACBDB6+0C   | 08D09         | . | ADEC13+00   | 01X13         | . | ANZRCT+00   | 04D05         | . | BELLO1+02   | 09X10         | . |
| AAMODD+00   | 11X13         | . | ACBDB7+0A   | 13B09         | . | ADEC13+00   | 12Y13         | . | ANZRCT+00   | 04D05         | . | BELLO1+03   | 09Y10         | . |
| AAMODE+00   | 12X13         | . | ACBDB7+0B   | 11D09         | . | ADEC14+00   | 01X13         | . | APARER+00   | 01A10         | . | BELLCT+00   | 12A10         | . |
| AAPEEN+00   | 10Z07         | . | ACBDB7+0C   | 09D09         | . | ADEC14+00   | 13Y13         | . | APARER+00   | 01D09         | . | BELLEN+00   | 13X10         | . |
| AAROLL+00   | 05A07         | . | ACBDB8+0C   | 10A10         | . | ADEC15+00   | 01X13         | . | APARER+11   | 01X10         | . | BFWDCT+00   | 12A05         | . |
| AAROLL+00   | 08A07         | . | ACIN01+0A   | 04A05         | . | ADEC15+00   | 13A13         | . | APTSON+00   | 11X10         | . | BLKVID+00   | 04D02         | . |
| AARRST+00   | 01X08         | . | ACIN02+0A   | 04A05         | . | ADR000+00   | 01A08         | . | APTYON+00   | 12Y10         | . | BLKVID+XX   | 08Z02         | . |
| AAZRCT+00   | 02D05         | . | ACIN04+0A   | 04A05         | . | ADR001+00   | 01A08         | . | APTYON+0A   | 12Z10         | . | BLKVID+00   | 08D02         | . |
| ABCOMP+00   | 13X06         | . | ACIN08+0A   | 04A05         | . | ADR002+00   | 01A08         | . | APTYON+0B   | 12D10         | . | BLKVID+0X   | 03D02         | . |
| ABELRS+00   | 13A10         | . | ACIN16+0A   | 07B05         | . | ADR003+00   | 04A08         | . | ARCLRY+00   | 07Y11         | . | BLKVID+XX   | 08Z02         | . |
| ABILL1+00   | 02A11         | . | ACIN32+0A   | 01A05         | . | ADR003+01   | 01A08         | . | ARTRDY+00   | 01D09         | . | BRIADJ+00   | 07A01         | . |
| ABUF01+00   | 03A06         | . | ACIN64+0A   | 01A05         | . | ADR004+00   | 04A08         | . | ATOLFD+00   | 10A07         | . | BRIGHT+00   | 07A01         | . |
| ABUF02+00   | 03A06         | . | ACLRDY+00   | 07Z11         | . | ADR004+01   | 07A08         | . | AVIDEO+00   | 01C03         | . | BRIGLO+00   | 07A01         | . |
| ABUF03+00   | 03A06         | . | ACOMUN+13   | 01A01         | . | ADR005+00   | 04A08         | . | AXICKF+00   | 10Y06         | . | BRKCNT+00   | 09X11         | . |
| ABUF04+00   | 03A06         | . | ACOMUN+09   | 05A02         | . | ADR006+00   | 04A08         | . | AXICKF+00   | 10Z06         | . | BRKLTH+00   | 11A11         | . |
| ABUF05+00   | 03A06         | . | ACTLNF+00   | 12Z05         | . | ADR007+00   | 10B08         | . | AXLNMD+00   | 10A06         | . | BRKLTH+00   | 09A11         | . |
| ABUF06+00   | 03A06         | . | ACTNDN+00   | 07Z07         | . | ADR008+00   | 10B08         | . | AXLNMD+00   | 08A06         | . | BUFHMD+00   | 08X12         | . |
| ABUF07+00   | 01A06         | . | ACTNUP+00   | 09Z07         | . | ADR009+00   | 07A08         | . | AXMSN1+0A   | 02X12         | . | BUFINH+00   | 05A14         | . |
| ABUF08+00   | 01A06         | . | ADEC00+00   | 01X13         | . | ADRCRY+00   | 08B08         | . | AXMSN1+0X   | 10D06         | . | BUFINH+00   | 05X14         | . |
| ABUF09+00   | 01A06         | . | ADEC00+00   | 01Y13         | . | ADRXMT+00   | 06A14         | . | AXMSN1+00   | 11Z06         | . | BUFMOD+00   | 03Z12         | . |
| ABUF10+00   | 01A06         | . | ADEC01+00   | 01X13         | . | ADRXMT+00   | 06X14         | . | AXMSN1+0A   | 11X06         | . | BUFMOD+00   | 06D01         | . |
| ABUF11+00   | 01A06         | . | ADEC01+00   | 02Y13         | . | AEXBIT+00   | 03Z14         | . | AXMSN1+0X   | 10D06         | . | BVIDEO+00   | 08A03         | . |
| ABUF12+00   | 01A06         | . | ADEC02+00   | 01X13         | . | AEXBIT+00   | 05Y14         | . | AXPGMD+00   | 07A06         | . | CARDET+01   | 04X12         | . |
| ACBDB1+0A   | 01B09         | . | ADEC02+00   | 03Y13         | . | AFWDCT+00   | 13X05         | . | AXPGMD+00   | 05A06         | . | CARRTN+00   | 12Z13         | . |
| ACBDB1+0B   | 01C09         | . | ADEC03+00   | 01X13         | . | AKYSTB+00   | 06Z07         | . | AYLOAD+00   | 08D14         | . | CCTRO1+00   | 04B05         | . |
| ACBDB1+0C   | 09A09         | . | ADEC03+00   | 04Y13         | . | AKYSTB+00   | 09C06         | . | BACKEN+00   | 04Y14         | . | CCTRO2+00   | 04B05         | . |
| ACBDB2+0A   | 03B09         | . | ADEC04+00   | 01X13         | . | ALCL01+00   | 01A07         | . | BACKEN+00   | 04X14         | . | CCTRO4+00   | 04B05         | . |

NOTE AN ASTERIK IN THE COLUMN(S) LABELED N INDICATES A NARRATIVE FOR THE GIVEN SIGNAL(S). NARRATIVES ARE SHOWN AT THE END OF THE REPORT.

HONEYWELL PROPRIETARY AND CONFIDENTIAL

LOGIC BLOCK DIAGRAM GLOSSARY/INDEX  
TTY-C CRT DISPLAY

DOCUMENT NO. REV.  
GLB60130734-001 B

BOARD NAME ASSEMBLY DOC. NO.  
BE2TCY 60130730

PAGE 3 OF 5  
EDITED 08/17/77

| SIGNAL NAME | ROW/COL /PAGE | N | SIGNAL NAME | ROW/COL /PAGE | N | SIGNAL NAME | ROW/COL /PAGE | N | SIGNAL NAME | ROW/COL /PAGE | N | SIGNAL NAME | ROW/COL /PAGE | N |
|-------------|---------------|---|-------------|---------------|---|-------------|---------------|---|-------------|---------------|---|-------------|---------------|---|
| CCTR08+00   | 04B05         | . | COMDAT-23   | 11Z12         | . | CRTSND+00   | 01Z12         | . | DATBT6-0D   | 08Y10         | . | DMYL02+00   | 04A10         | . |
| CCTR16+00   | 01B05         | . | COMDAT+01   | 01D09         | . | CTFWRD+00   | 10Y05         | . | DATBT6-YY   | 08Y14         | . | DMYL17-00   | 01A12         | . |
| CCTR32-00   | 03C05         | . | COMDAT+02   | 07Y12         | . | CTMXVD-00   | 08Y02         | . | DATBT6+0C   | 06A13         | . | DOTCLD-00   | 02A02         | . |
| CCTR32+00   | 01B05         | . | COMDAT+03   | 13Y12         | . | CTSEND-00   | 13X12         | . | DATBT7-0C   | 09D10         | . | DOTCT1+10   | 02A02         | . |
| CCTR64-00   | 02C05         | . | COMDAT+13   | 09Y12         | . | CTSEND+00   | 08Y12         | . | DATBT7-YY   | 07Y14         | . | DOTCT2+10   | 02A02         | . |
| CCTR64+00   | 01B05         | . | COMDAT+14   | 12D06         | . | CTSND1-00   | 06D01         | . | DATBT7+0C   | 07A13         | . | DOTCT4+10   | 02A02         | . |
| CCTRBO+00   | 04B05         | . | COMDAT+15   | 09Z12         | . | CURSDN-00   | 03Z13         | . | DATBTS+00   | 08Z14         | . | DTFWRD-00   | 11X05         | . |
| CCTRCA+00   | 04B05         | . | COMDAT+16   | 07Y12         | . | CURSLF-00   | 05Z13         | . | DATCLK+00   | 08A11         | . | DTFWRD+00   | 05Y11         | . |
| CCTRSM-01   | 13Y10         | . | COMDAT+19   | 12Z06         | . | CURSLF-1X   | 08D05         | . | DATCON-00   | 07X11         | . | DVIDEO-00   | 03D03         | . |
| CGBIT1+00   | 01B03         | . | COMDAT+23   | 06D01         | . | CURSLF+00   | 08Y05         | . | DATCON-1Z   | 01A11         | . | DVIDEO+00   | 13Z03         | . |
| CGBIT2+00   | 01B03         | . | COMDAT+40   | 06D01         | . | CURSRT-00   | 04Z13         | . | DATCON+00   | 02X11         | . | DVIDEO+01   | 07C01         | . |
| CGBIT3+00   | 01B03         | . | COMEIA-00   | 05A02         | . | CURSUP-00   | 02Z13         | . | DATERR+00   | 06D01         | . | DVIDEO+0A   | 13Y03         | . |
| CGBIT4+00   | 01B03         | . | COMEIA-01   | 01A01         | . | CVIDEO-02   | 07B03         | . | DATRDRY+00  | 08X11         | . | DVIDEO+0B   | 01D03         | . |
| CGBIT5+00   | 01B03         | . | COMEIA+00   | 11Y12         | . | CVIDEO+01   | 04C03         | . | DATSTR+00   | 02A14         | . | EIACFD+00   | 01A01         | . |
| CHIPEN-01   | 11C08         | . | COMIN1+00   | 01D09         | . | CVIDEO+02   | 05C03         | . | DCLEAR-00   | 12Y03         | . | EIACFD+1X   | 05A12         | . |
| CHIPEN+01   | 08B08         | . | CUMIN2+00   | 01D09         | . | DATAIN-00   | 03C15         | . | DCLEAR-17   | 06D06         | . | EIACTS+00   | 01A01         | . |
| CHMCP+00    | 04B06         | . | COMIN3+00   | 01D09         | . | DATBT1-0A   | 03D10         | . | DCLEAR-21   | 13A03         | . | EIACTS+1X   | 12X12         | . |
| CLKCON-00   | 03A11         | . | COMIN4+00   | 01D09         | . | DATBT1-0C   | 03Z10         | . | DCLEAR+00   | 12Y03         | . | EIADSR+00   | 01A01         | . |
| CLOCK1-00   | 11A02         | . | COMIN5+00   | 01D09         | . | DATBT1-0D   | 03Y10         | . | DCLEAR+07   | 03Y11         | . | EIADSR+1X   | 01A14         | . |
| CLOCK1-01   | 13B02         | . | COMIN6+00   | 01D09         | . | DATBT1+0C   | 01A13         | . | DCLEAR+17   | 07C06         | . | ELERAS-00   | 11Z13         | . |
| CLOCK1-02   | 12X02         | . | COMIN7+00   | 01D09         | . | DATBT2-0A   | 04D10         | . | DCLEAR+21   | 13A03         | . | ELEVNX+00   | 03D07         | . |
| CLOCK1-03   | 10Y02         | . | COMLIN-05   | 01A01         | . | DATBT2-0C   | 04Z10         | . | DCLRDRY-00  | 06Z11         | . | ELEVNY+00   | 02D07         | . |
| CLOCK1-04   | 11Z02         | . | COMLIN-11   | 07D12         | . | DATBT2-0D   | 04Y10         | . | DCLRDRY+00  | 06Z11         | . | ENBCLK+00   | 01D11         | . |
| CLOCK1+00   | 11D02         | . | COMLIN+01   | 01A01         | . | DATBT2+0C   | 02A13         | . | DECB67-00   | 11A13         | . | ENSPAC-0A   | 01Z10         | . |
| CLOCK1+01   | 11Y02         | . | COMLIN+17   | 07Z12         | . | DATBT3-0A   | 05D10         | . | DECB67+00   | 12A13         | . | ENSPAC+00   | 01Y10         | . |
| CLRRDLS-21  | 13X03         | . | COMRES-13   | 05A02         | . | DATBT3-0C   | 05Z10         | . | DECDEL-00   | 13X13         | . | EPGCLR-00   | 10Z13         | . |
| CLRRDY-00   | 06X11         | . | COMRRT-01   | 05X12         | . | DATBT3-0D   | 05Y10         | . | DEXBIT-00   | 07A11         | . | ERSBLK-00   | 04A03         | . |
| CLRRDY+00   | 06X11         | . | COMTRE+00   | 01D09         | . | DATBT3+0C   | 03A13         | . | DISENA-00   | 03D06         | . | ERSBLK+88   | 04A03         | . |
| CNT064-00   | 06B08         | . | CON7NX+00   | 10A13         | . | DATBT4-0A   | 06D10         | . | DISENA+00   | 13A08         | . | ERSCAP+00   | 06A03         | . |
| CNT064+00   | 07Y08         | . | CON7PX+00   | 08A13         | . | DATBT4-0C   | 06Z10         | . | DLITDT+00   | 07A15         | . | ERSRES+00   | 07A03         | . |
| CNT064+10   | 07A08         | . | CRCOMP-05   | 13Z06         | . | DATBT4-0D   | 06Y10         | . | DLYEXT-00   | 01A12         | . | ESCAPE+00   | 11D13         | . |
| COMCLK-00   | 12Y06         | . | CRCOMP-5X   | 13Y06         | . | DATBT4+0C   | 04A13         | . | DLYINH+00   | 06D11         | . | ESCAPX-00   | 13A15         | . |
| COMDAT-00   | 10D12         | . | CRCOMP+01   | 04D03         | . | DATBT5-00   | 05X13         | . | DMYB04-00   | 05A11         | . | ETXSW1+00   | 01A09         | . |
| COMDAT-01   | 06A12         | . | CRCOMP+02   | 07D03         | . | DATBT5-0A   | 07D10         | . | DMYB06-00   | 03C15         | . | ETXSW2+00   | 01A09         | . |
| COMDAT-03   | 07X12         | . | CRCOMP+04   | 10D03         | . | DATBT5-0C   | 07Z10         | . | DMYB18+00   | 08B08         | . | ETXSW3+00   | 01A09         | . |
| COMDAT-0C   | 03D01         | . | CRDYCK-00   | 06Y11         | . | DATBT5-0D   | 07Y10         | . | DMYC05-00   | 05Z11         | . | ETXSW4+00   | 01A09         | . |
| COMDAT-0D   | 07A05         | . | CRDYCK+00   | 11D01         | . | DATBT5+0C   | 05A13         | . | DMYC08+00   | 12A06         | . | FDXRTS+00   | 01D12         | . |
| COMDAT-11   | 11D12         | . | CRSSTP-00   | 09X14         | . | DATBT6-0A   | 08D10         | . | DMYD02-00   | 03X11         | . | FREQ1P+00   | 10A14         | . |
| COMDAT-14   | 09D12         | . | CRSSTP+00   | 07X14         | . | DATBT6-0B   | 02Z10         | . | DMYE11+00   | 01D09         | . | FREQ2P+00   | 13A14         | . |
| COMDAT-19   | 12Z06         | . | CRSXMT-00   | 13Z13         | . | DATBT6-0C   | 08Z10         | . | DMYH08+XX   | 01A05         | . | FREQ3P+00   | 12A14         | . |

NOTE AN ASTERIK IN THE COLUMN(S) LABELED N INDICATES A NARRATIVE FOR THE GIVEN SIGNAL(S). NARRATIVES ARE SHOWN AT THE END OF THE REPORT.

HONEYWELL PROPRIETARY AND CONFIDENTIAL

LOGIC BLOCK DIAGRAM GLOSSARY/INDEX  
TTY-C CRT DISPLAY

DOCUMENT NO. REV.  
GLB60130734-001 B

BOARD NAME ASSEMBLY DOC. NO.  
BE2TCY 60130730

PAGE 4 OF 5  
EDITED 08/17/77

| SIGNAL NAME | ROW/COL /PAGE | N | SIGNAL NAME | ROW/COL /PAGE | N | SIGNAL NAME | ROW/COL /PAGE | N | SIGNAL NAME | ROW/COL /PAGE | N | SIGNAL NAME | ROW/COL /PAGE | N |
|-------------|---------------|---|-------------|---------------|---|-------------|---------------|---|-------------|---------------|---|-------------|---------------|---|
| FREQ4P+00   | 13Z14         | . | KBDD84+0Z   | 01C01         | . | LN RACE-00  | 04C06         | . | MCNT02+00   | 01B07         | . | NTWHRE+00   | 04D05         | . |
| FREQCP+00   | 10Y14         | . | KBDD85+00   | 10D15         | . | LN RACE+00  | 04C06         | . | MCNT04-00   | 03C07         | . | NW81CT+00   | 12Y05         | . |
| FWDLNF-00   | 08X05         | . | KBDD85+0Z   | 01C01         | . | LN XMIT-00  | 09Z13         | . | MCNT04+00   | 01B07         | . | NW MODA+00  | 04X13         | . |
| FWDLNF+00   | 09Y05         | . | KBDD86+00   | 10D15         | . | LOADSP-00   | 02C06         | . | MCNT08-00   | 04C07         | . | NX81CT+00   | 10X07         | . |
| HDXRTS-00   | 01Y12         | . | KBDD86+0Z   | 01C01         | . | LOADSP-0C   | 06C06         | . | MCNT08+00   | 01B07         | . | NZERCT-00   | 04D05         | . |
| HEREIS-00   | 01C01         | . | KBDD87-00   | 01B15         | . | LOADSP+00   | 02C06         | . | MCNT16-00   | 05C07         | . | NZERCT+00   | 04D05         | . |
| HRSYNC-00   | 06Y02         | . | KBDD87+00   | 01B15         | . | LSTCHR-00   | 13A05         | . | MCNT16+00   | 04X07         | . | PARINH+00   | 01A09         | . |
| HRSYNC-01   | 03Z02         | . | KBDD87+0Z   | 01C01         | . | LSTCHR+00   | 01X11         | . | MEPLEE+00   | 07A05         | . | PARSEL+00   | 01A09         | . |
| HRSYNC-02   | 06Z02         | . | KBDD88+0Z   | 01C01         | . | MBIT01+01   | 07C04         | . | MLNCMP+00   | 01B06         | . | PCLEAR-00   | 01Z13         | . |
| HRSYNC-03   | 03Y02         | . | KBDMUX+00   | 11X15         | . | MBIT01+0A   | 01A04         | . | MRCT01-00   | 04X08         | . | PCLEAR-XX   | 02D13         | . |
| HRSYNC-04   | 05D02         | . | KB DSTB-00  | 13A11         | . | MBIT01+0B   | 04A04         | . | MRCT01-0A   | 13B08         | . | PCLEAR+XX   | 01D13         | . |
| HRSYNC-22   | 09Z02         | . | KB DSTB-02  | 03A10         | . | MBIT01+0C   | 13A04         | . | MRCT01-0B   | 12B08         | . | PELOAD-00   | 09D05         | . |
| HRSYNC+00   | 04Z02         | . | KB DSTB+01  | 13X11         | . | MBIT02+01   | 07C04         | . | MRCT01+00   | 13C08         | . | PGCMPR-00   | 08C06         | . |
| HRSYNC+01   | 01D02         | . | KB DSTB+02  | 11D11         | . | MBIT02+0A   | 07A04         | . | MRCT02+00   | 10A08         | . | PGCMPR+00   | 07B06         | . |
| HRSYNC+02   | 01Z02         | . | KB DSTB+0C  | 13Y11         | . | MBIT02+0B   | 10A04         | . | MRCT04+00   | 10A08         | . | PGMODE-00   | 06D01         | . |
| HRSYNC+04   | 06D02         | . | KB DSTB+0Z  | 01C01         | . | MBIT02+0C   | 13X04         | . | MRCT08+00   | 10A08         | . | PGMODE+00   | 08D13         | . |
| HRSYNC+22   | 09D02         | . | LCLOAD-00   | 08C03         | . | MBIT03+01   | 07C04         | . | MRCT16+00   | 10A08         | . | PGXMIT-00   | 09D13         | . |
| HRSYNC+24   | 10A05         | . | LCLOAD-01   | 11C03         | . | MBIT03+0A   | 01B04         | . | MS132C+00   | 08D11         | . | PPADTR-00   | 13A12         | . |
| INBIT1+0A   | 04A15         | . | LCLOAD-02   | 07C03         | . | MBIT03+0B   | 04B04         | . | NAXCKC+00   | 07X07         | . | PPARCD-00   | 01B01         | . |
| INBIT1+0B   | 01A15         | . | LCLOAD-03   | 11B03         | . | MBIT03+0C   | 13Y04         | . | NAXCKF-00   | 12A15         | . | PPARCD+01   | 07A12         | . |
| INBIT1+0C   | 05X15         | . | LCLOAD+01   | 08B03         | . | MBIT04+01   | 07C04         | . | NCARTN-00   | 11D05         | . | PPARCD+0X   | 08A12         | . |
| INBIT2+00   | 05Y15         | . | LCLOAD+02   | 12Z03         | . | MBIT04+0A   | 07B04         | . | NCLR DY-00  | 08Y11         | . | PPARTS+00   | 02D12         | . |
| INBIT3+00   | 05Z15         | . | LLCASE-00   | 04C05         | . | MBIT04+0B   | 10B04         | . | NCLR DY+00  | 02Y11         | . | PPATXD-00   | 03Y12         | . |
| INCCCT-00   | 03D11         | . | LLCASE-01   | 05A02         | . | MBIT04+0C   | 13Z04         | . | NCROMP-04   | 12X03         | . | PPDSRS+0Z   | 11X12         | . |
| INCTS X-00  | 03X14         | . | LNCT01+00   | 01A03         | . | MBIT05+01   | 07C04         | . | NCROMP+04   | 12A03         | . | PTRXXX-00   | 11D10         | . |
| INCTS X-0A  | 03A14         | . | LNCT02+00   | 01A03         | . | MBIT05+0A   | 01C04         | . | NCRTEN+00   | 12Z15         | . | PULLUP+00   | 10D07         | . |
| INCTS X-0B  | 04A14         | . | LNCT04+00   | 01A03         | . | MBIT05+0B   | 04C04         | . | NCRTSD-00   | 12Y15         | . | PULLUP+01   | 06D01         | . |
| INCTS X+00  | 06D01         | . | LNCT08-00   | 05B03         | . | MBIT05+0C   | 12C04         | . | NCRTSD+00   | 05D12         | . | PULLUP+02   | 13A02         | . |
| INHCLK-00   | 12Y02         | . | LNCT08+00   | 01A03         | . | MBIT06+01   | 09C04         | . | NDTC ON-1X  | 01Z11         | . | PULLUP+03   | 12D05         | . |
| INLNFD-00   | 11Z05         | . | LNCT09-00   | 06B03         | . | MBIT06+0A   | 07C04         | . | NDTFWD-00   | 11Y05         | . | PULLUP+04   | 01D06         | . |
| INMSTC-00   | 08Y07         | . | LNCT09+00   | 06C03         | . | MBIT06+0B   | 10C04         | . | NENSPC-00   | 02Z11         | . | PULLUP+06   | 11X11         | . |
| IVIDEU+00   | 05D15         | . | LNFEED-00   | 10D13         | . | MBIT06+0C   | 11C04         | . | NEW DTR+01  | 06A01         | . | PULLUP+08   | 07A07         | . |
| KBDBKK-00   | 01C01         | . | LNFEED+00   | 09X07         | . | MBIT07+01   | 07C04         | . | NEWSTB+00   | 02X10         | . | PULLUP+09   | 07A05         | . |
| KBDD81+00   | 10D15         | . | LNFEED+10   | 01C06         | . | MBIT07+0A   | 01C04         | . | NEXBIT-00   | 05A11         | . | PULLUP+10   | 09Z12         | . |
| KBDD81+0Z   | 01C01         | . | LNFEED+11   | 03C06         | . | MBIT07+0B   | 04C04         | . | NFW DCT-00  | 13Y05         | . | PWRISO+00   | 01D14         | . |
| KBDD82+00   | 10D15         | . | LNFEED-10   | 12Z14         | . | MBIT07+0C   | 10C04         | . | NINLFD-00   | 10Z05         | . | PWRISO+0A   | 01Z14         | . |
| KBDD82+0Z   | 01C01         | . | LNFEED-20   | 11Z14         | . | MBIT16+00   | 06C05         | . | NLNLFED-00  | 09Y07         | . | PWRISO+0B   | 02Z14         | . |
| KBDD83+00   | 10D15         | . | LNFEED+00   | 11Y14         | . | MCNT01-00   | 01C07         | . | NLNG1+00    | 01Y11         | . | PWRONI+00   | 06D01         | . |
| KBDD83+0Z   | 01C01         | . | LNMODE-00   | 06D01         | . | MCNT01+00   | 01B07         | . | NODATA-00   | 12D15         | . | PWRRST-00   | 07A14         | . |
| KBDD84+00   | 10D15         | . | LNMODE+00   | 06D13         | . | MCNT02-00   | 02C07         | . | NTWHRE-00   | 04D05         | . | PWRTON-00   | 10Z10         | . |

NOTE AN ASTERIK IN THE COLUMN(S) LABELED N INDICATES A NARRATIVE FOR THE GIVEN SIGNAL(S). NARRATIVES ARE SHOWN AT THE END OF THE REPORT.

HONEYWELL PROPRIETARY AND CONFIDENTIAL

LOGIC BLOCK DIAGRAM GLOSSARY/INDEX  
TTY-C CRT DISPLAY

DOCUMENT NO. REV.  
GLB60130734-001 B

BOARD NAME ASSEMBLY DOC. NO.  
BE2TCY 60130730

PAGE 5 OF 5  
EDITED 08/17/77

| SIGNAL NAME | ROW/COL /PAGE | N | SIGNAL NAME | ROW/COL /PAGE | N | SIGNAL NAME | ROW/COL /PAGE | N | SIGNAL NAME | ROW/COL /PAGE | N | SIGNAL NAME | ROW/COL /PAGE | N |
|-------------|---------------|---|-------------|---------------|---|-------------|---------------|---|-------------|---------------|---|-------------|---------------|---|
| PWRTON+00   | 10Y10         | . | RPCT02-00   | 12D11         | . | STXMIT+5C   | 11Y15         | . | WRCT04+00   | 03X11         | . |             |               | . |
| RAMC00+00   | 04X02         | . | RPCT02+00   | 09Y11         | . | SYNCCT+00   | 08X02         | . | WRCTSM-00   | 03X11         | . |             |               | . |
| RAMC00+XX   | 07D11         | . | RPCTXX+00   | 09Y11         | . | TERVN5-00   | 05A12         | . | WRENAB-00   | 05Z11         | . |             |               | . |
| RAMC01+00   | 04X02         | . | RPTKEY-01   | 12Y11         | . | TESTCK-00   | 12Z02         | . | XB1CTN+00   | 07Y07         | . |             |               | . |
| RAMC02+00   | 04X02         | . | RPTKEY-02   | 12Z11         | . | THRCNT+00   | 12Y12         | . | XERMOY+00   | 04D07         | . |             |               | . |
| RAMC04-00   | 07Y02         | . | RPTKEY-04   | 10D11         | . | TMXCAP+00   | 03A12         | . | XLDSRT-00   | 04Z14         | . |             |               | . |
| RAMC04+00   | 04X02         | . | RPTKEY-0Z   | 01C01         | . | TMXRES+00   | 04A12         | . | XLDSRT+00   | 05Y14         | . |             |               | . |
| RAMCRY+00   | 04X02         | . | RPTKEY+00   | 12A11         | . | TWTHRE+00   | 05E07         | . | XMTFWD-00   | 12X05         | . |             |               | . |
| RCNT01-00   | 01Y08         | . | RPTKEY+02   | 10Z11         | . | TXDAT0-11   | 05Y12         | . | XMTFWD+00   | 10X05         | . |             |               | . |
| RCNT01+00   | 01Y08         | . | RTSEXT-00   | 04D12         | . | URCLMX+00   | 11A05         | . | XMTRST-00   | 08D06         | . |             |               | . |
|             |               | . |             |               | . |             |               | . |             |               | . |             |               | . |
| RCNT02+00   | 03Y08         | . | RTSHDX-00   | 01X12         | . | URSEL1-00   | 09X15         | . | XMTRST-0A   | 11D06         | . |             |               | . |
| RCNT04+00   | 03Y08         | . | RTSHDX+00   | 03X12         | . | URSEL1+00   | 09X15         | . | XYCRSN-00   | 06Z13         | . |             |               | . |
| RCNT08-00   | 03C08         | . | RTSLTH-00   | 06Z12         | . | URSEL2-00   | 09Y15         | . | XYLOAD-00   | 07D14         | . |             |               | . |
| RCNT08+00   | 03Y08         | . | RTSLTH+00   | 04Z12         | . | URSEL2+00   | 09Y15         | . | XZERCT-00   | 11A07         | . |             |               | . |
| RCNT11+10   | 04Z08         | . | RTSPLS-00   | 04Y12         | . | URTHRE+00   | 01L09         | . | XZERCT+00   | 08X07         | . |             |               | . |
| RCNT16+00   | 03Y08         | . | RWLINE-00   | 05D11         | . | VCCT16+00   | 01X02         | . | YB1CTN-00   | 10Y07         | . |             |               | . |
| RDULIT-00   | 04D13         | . | RWLINE+00   | 04D11         | . | VCCT32-00   | 02Y02         | . | YLDSTRT-00  | 05Z14         | . |             |               | . |
| RESETC-00   | 01Z08         | . | S00000+00   | 11Y07         | . | VCCT32+00   | 01X02         | . | YLDSTRT+00  | 05Y14         | . |             |               | . |
| RLNFED-00   | 09A07         | . | S00001+00   | 11Y07         | . | VCCT64+00   | 01X02         | . |             |               | . |             |               | . |
| ROW004-02   | 06Z08         | . | S00002+00   | 11Y07         | . | VCLOAD-00   | 01Y02         | . |             |               | . |             |               | . |
|             |               | . |             |               | . |             |               | . |             |               | . |             |               | . |
| ROW004-04   | 09C08         | . | S00003+00   | 11Y07         | . | VIDRES-00   | 10C14         | . |             |               | . |             |               | . |
| ROW004-14   | 10C08         | . | SENDIX-1Z   | 11Y06         | . | VRCT01-00   | 09C03         | . |             |               | . |             |               | . |
| ROW004+00   | 01D08         | . | SENDIX+0Z   | 01C01         | . | VRCT01+00   | 09C03         | . |             |               | . |             |               | . |
| ROW004+02   | 10B08         | . | SET81X-00   | 08Z05         | . | VRCT02+00   | 09A03         | . |             |               | . |             |               | . |
| ROW004+03   | 10B08         | . | SET81X+00   | 07D05         | . | VRCT04-00   | 09B03         | . |             |               | . |             |               | . |
| ROW004+04   | 10B08         | . | SETZRO-00   | 10D05         | . | VRCT04+00   | 09A03         | . |             |               | . |             |               | . |
| ROW004+0A   | 05D08         | . | STBENL+00   | 02Y10         | . | VRCT08-00   | 07X02         | . |             |               | . |             |               | . |
| ROW004+0B   | 06D08         | . | STBINH+00   | 03B15         | . | VRCT08+00   | 09A03         | . |             |               | . |             |               | . |
| ROW008-00   | 11D08         | . | STBLTH-00   | 05X10         | . | VRCT16+00   | 09A03         | . |             |               | . |             |               | . |
| ROW008-01   | 07Z08         | . | STBLTH+00   | 03X10         | . | VRCTCO+00   | 09A03         | . |             |               | . |             |               | . |
|             |               | . |             |               | . |             |               | . |             |               | . |             |               | . |
| ROW008+00   | 03D08         | . | STBRST-00   | 02A10         | . | VRCTCU+00   | 12A06         | . |             |               | . |             |               | . |
| ROW008+0A   | 10D08         | . | STBRST+00   | 02A10         | . | VRCTCU+0D   | 10A10         | . |             |               | . |             |               | . |
| ROW008+0B   | 09D08         | . | STOPBL-00   | 07A10         | . | VRCTDX+00   | 09Z11         | . |             |               | . |             |               | . |
| ROX004-01   | 08Z08         | . | STOPBL+00   | 04A10         | . | VRLOAD-00   | 05A02         | . |             |               | . |             |               | . |
| ROY004-01   | 08D08         | . | STPBIT+00   | 01D15         | . | VTSYNC-00   | 08A02         | . |             |               | . |             |               | . |
| ROZ004-01   | 07D08         | . | STPBIT+99   | 01D15         | . | VTSYNC-01   | 10A02         | . |             |               | . |             |               | . |
| RPCT00-00   | 09D11         | . | STPCLR+00   | 10B03         | . | VTSYNC+02   | 05A02         | . |             |               | . |             |               | . |
| RPCT00+00   | 09Y11         | . | STRSTX-00   | 12X15         | . | VTSYNC+11   | 10X02         | . |             |               | . |             |               | . |
| RPCT01-00   | 08Z11         | . | STXMIT-00   | 11A15         | . | WDLINH-00   | 03L14         | . |             |               | . |             |               | . |
| RPCT01+00   | 09Y11         | . | STXMIT+00   | 09A15         | . | WDULIT-00   | 05L13         | . |             |               | . |             |               | . |

NOTE AN ASTERIK IN THE COLJMN(S) LABELED N INDICATES A NARRATIVE FOR THE GIVEN SIGNAL(S). NARRATIVES ARE SHOWN AT THE END OF THE REPORT.

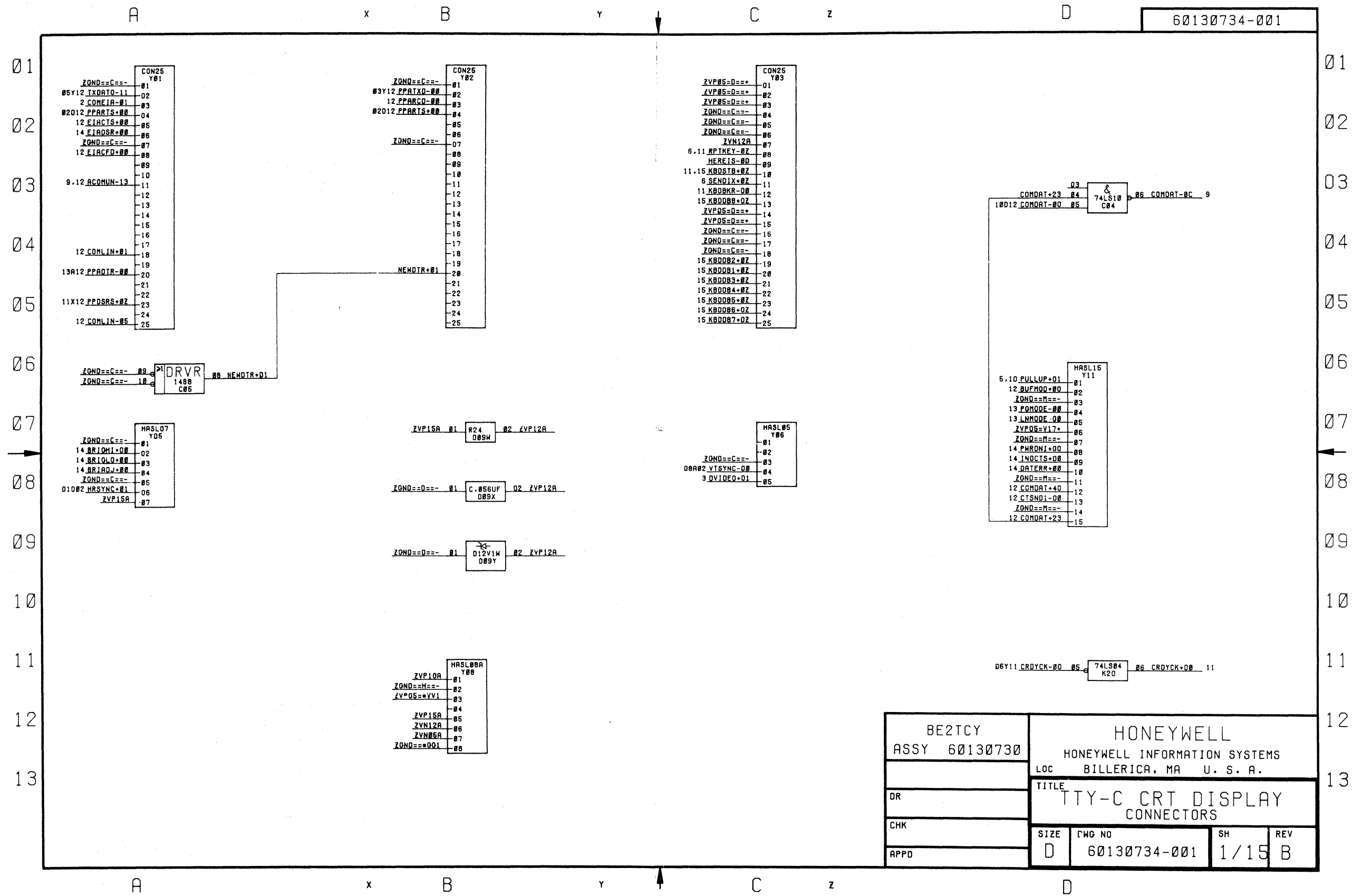

60130734-001

|                         |      |  |                        |            |          |
|-------------------------|------|--|------------------------|------------|----------|
| BE2TCY<br>ASSY 60130730 |      | HONEYWELL<br>HONEYWELL INFORMATION SYSTEMS<br>LOC BILLERICA, MA U. S. A. |                        |            |          |
| DR                      |      | TITLE<br>TTY-C CRT DISPLAY<br>CONNECTORS                                 |                        |            |          |
| CHK                     | APPD | SIZE<br>D  | CWG NO<br>60130734-001 | SH<br>1/15 | REV<br>B |

60130734-001

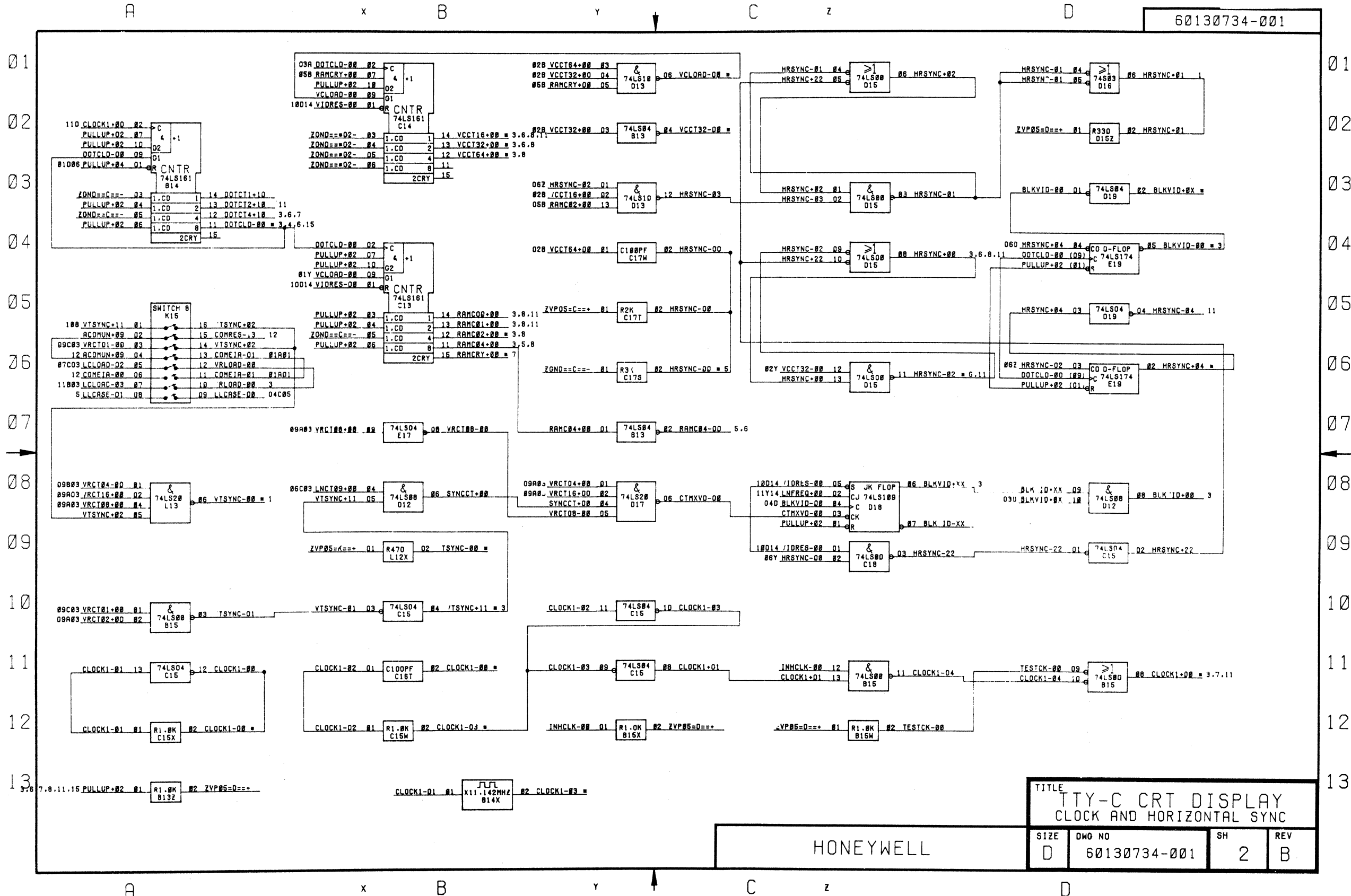

|                           |              |    |     |
|---------------------------|--------------|----|-----|
| TITLE                     |              |    |     |
| TTY-C CRT DISPLAY         |              |    |     |
| CLOCK AND HORIZONTAL SYNC |              |    |     |
| SIZE                      | DWG NO       | SH | REV |
| D                         | 60130734-001 | 2  | B   |

HONEYWELL



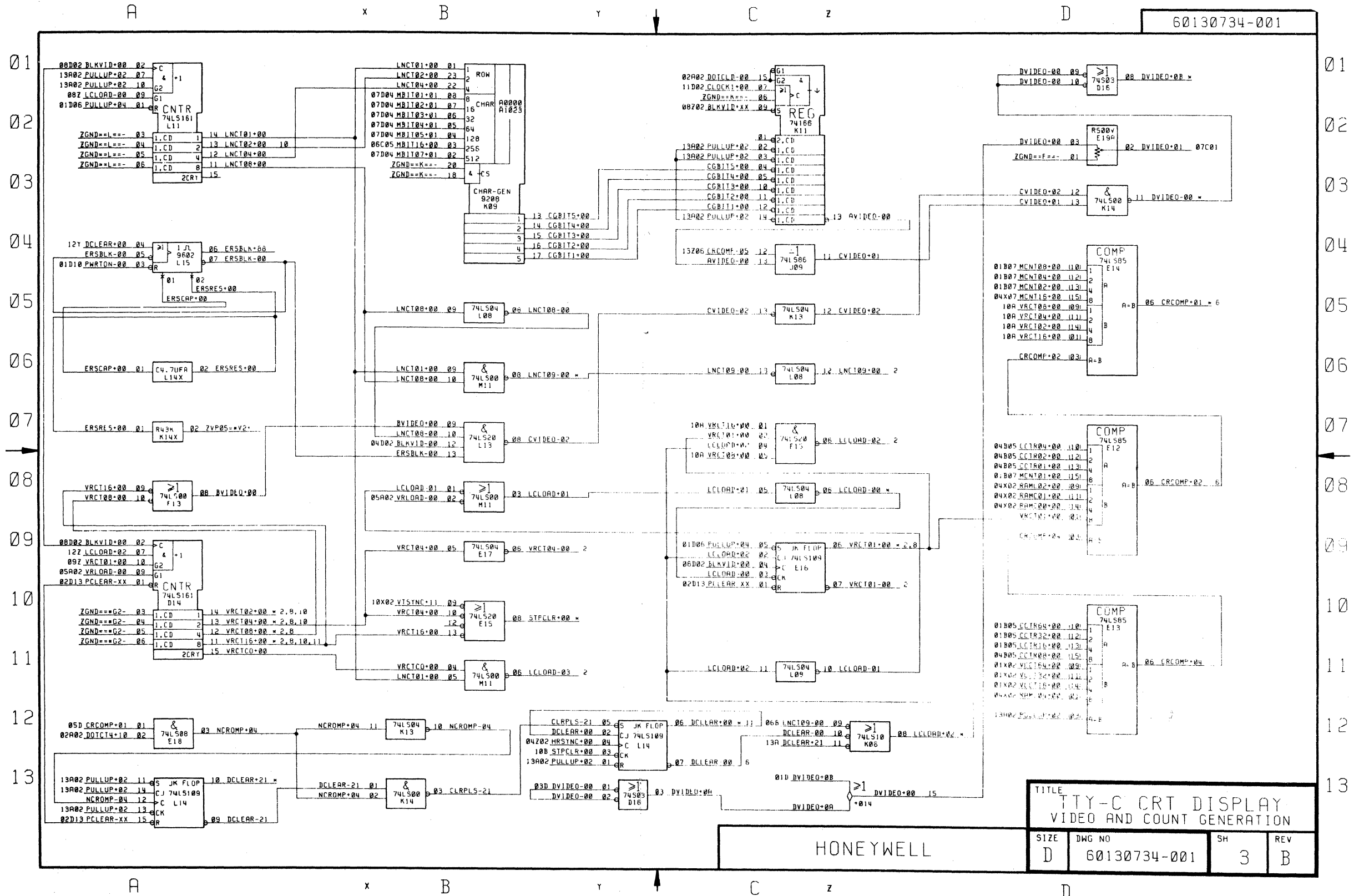

60130734-001

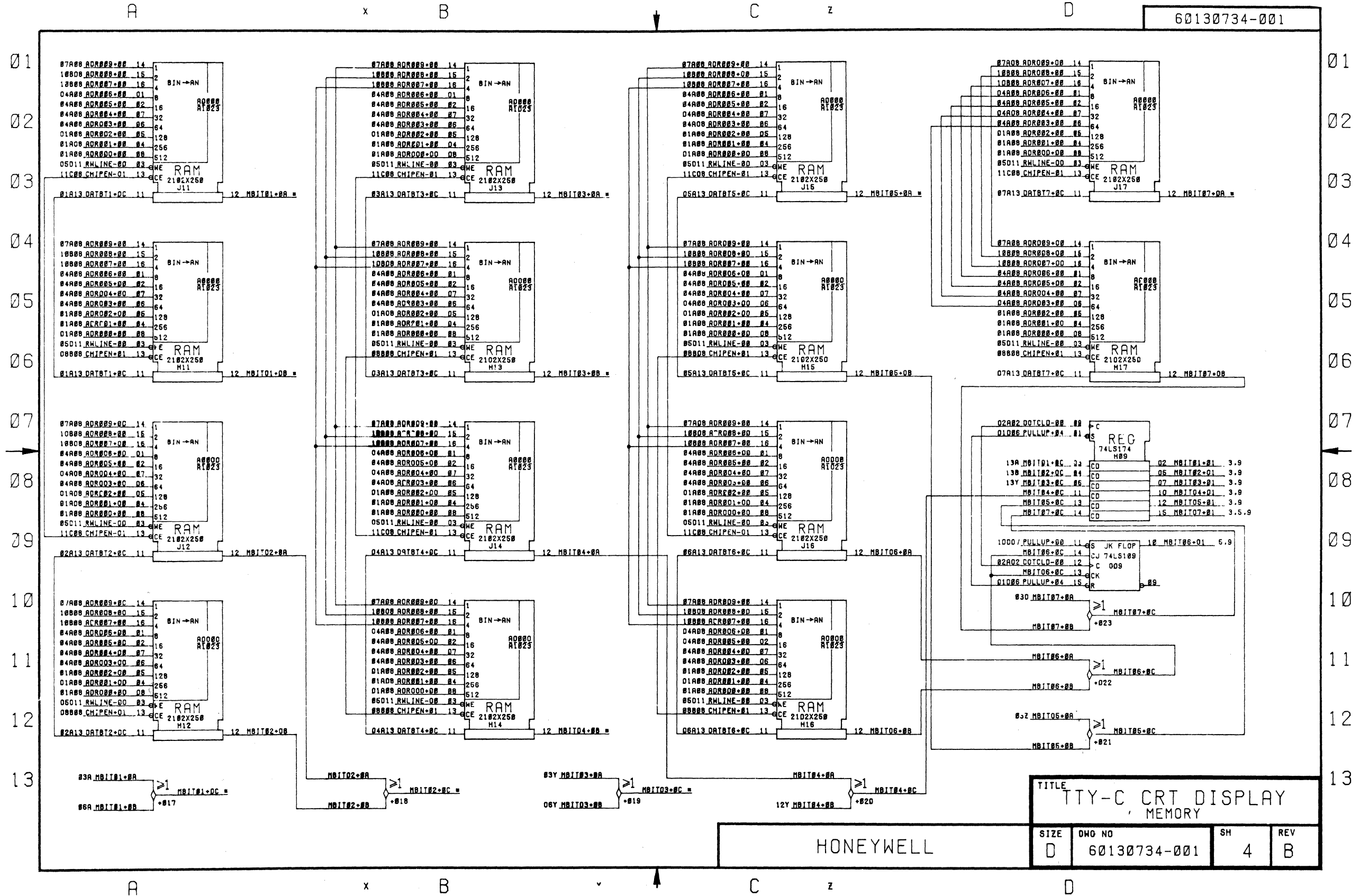

60130734-001

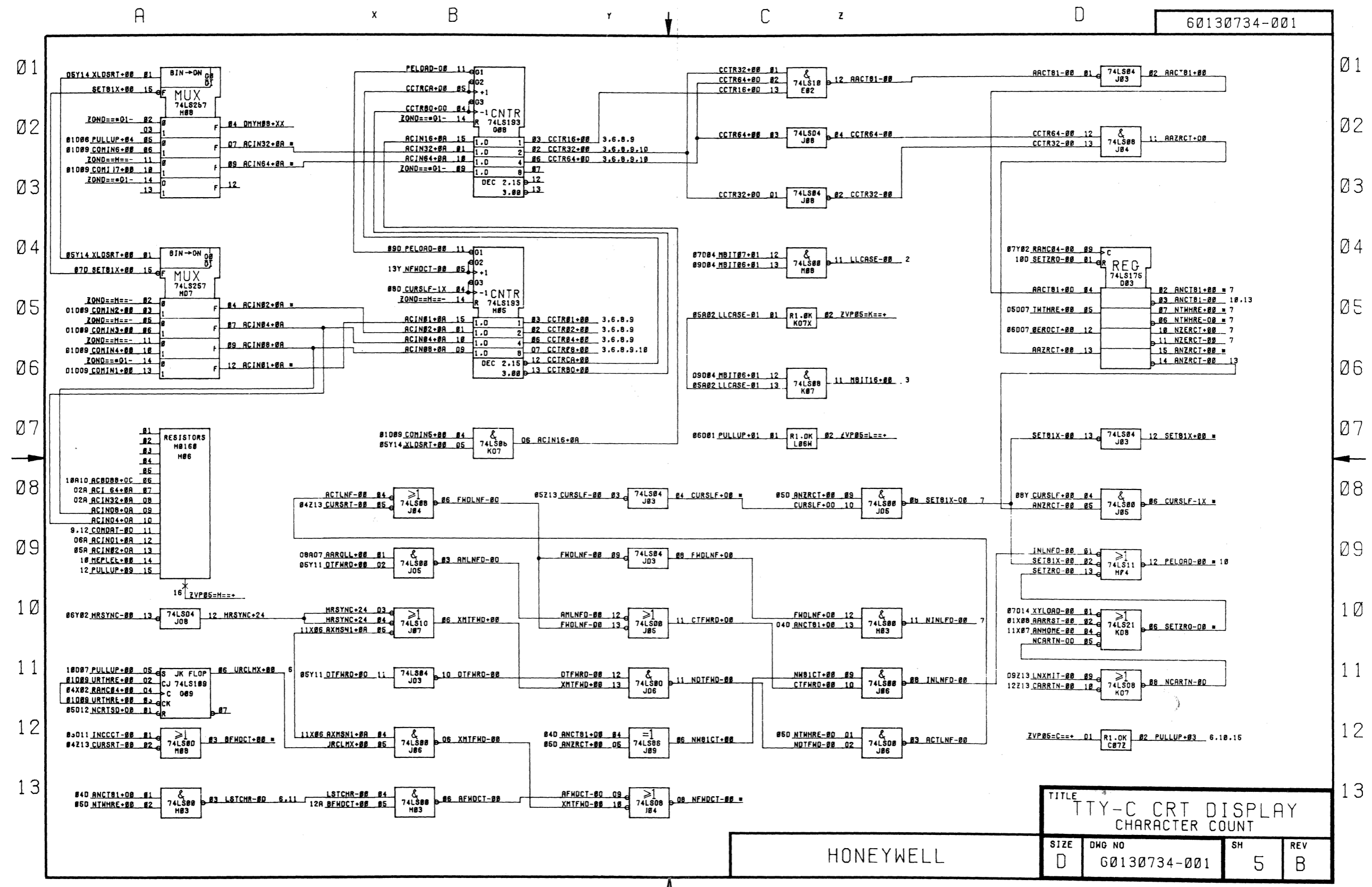

|                                   |              |    |     |
|-----------------------------------|--------------|----|-----|
| TITLE                             |              |    |     |
| TTY-C CRT DISPLAY CHARACTER COUNT |              |    |     |
| SIZE                              | DWG NO       | SH | REV |
| D                                 | 60130734-001 | 5  | B   |

HONEYWELL

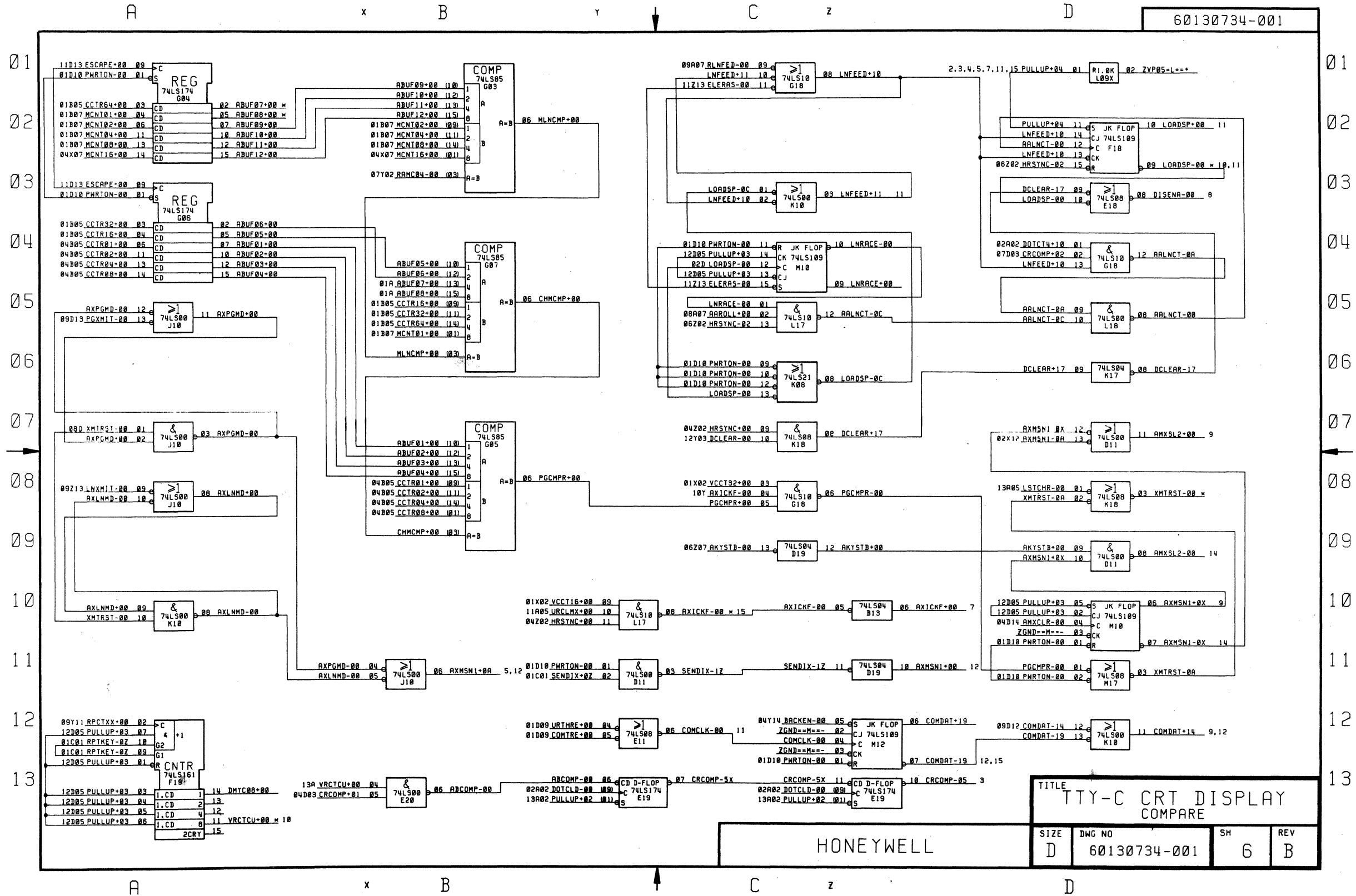

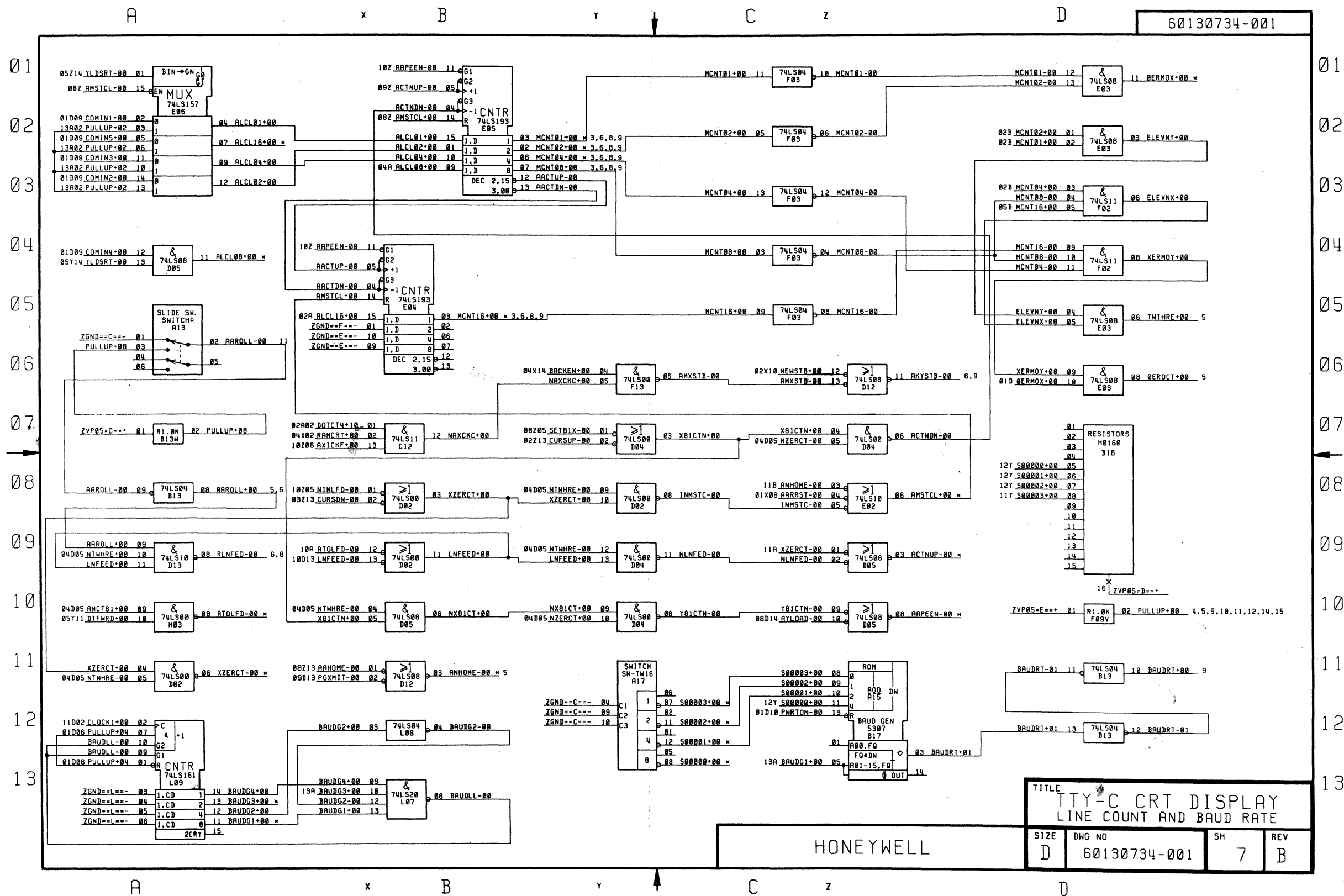

|                          |              |    |     |
|--------------------------|--------------|----|-----|
| TITLE                    |              |    |     |
| TTY-C CRT DISPLAY        |              |    |     |
| LINE COUNT AND BAUD RATE |              |    |     |
| SIZE                     | DWG NO       | SH | REV |
| D                        | 60130734-001 | 7  | B   |

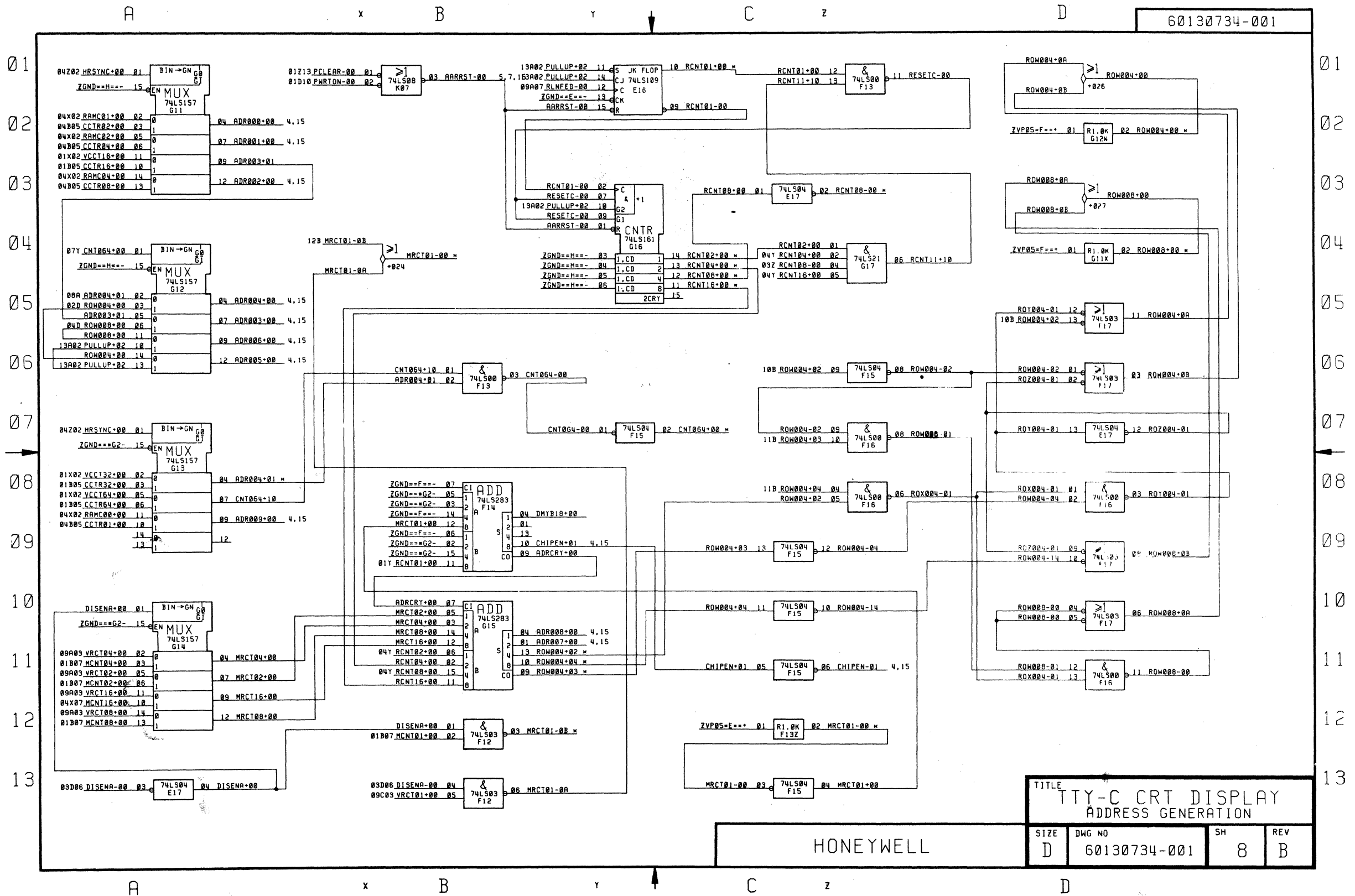

60130734-001

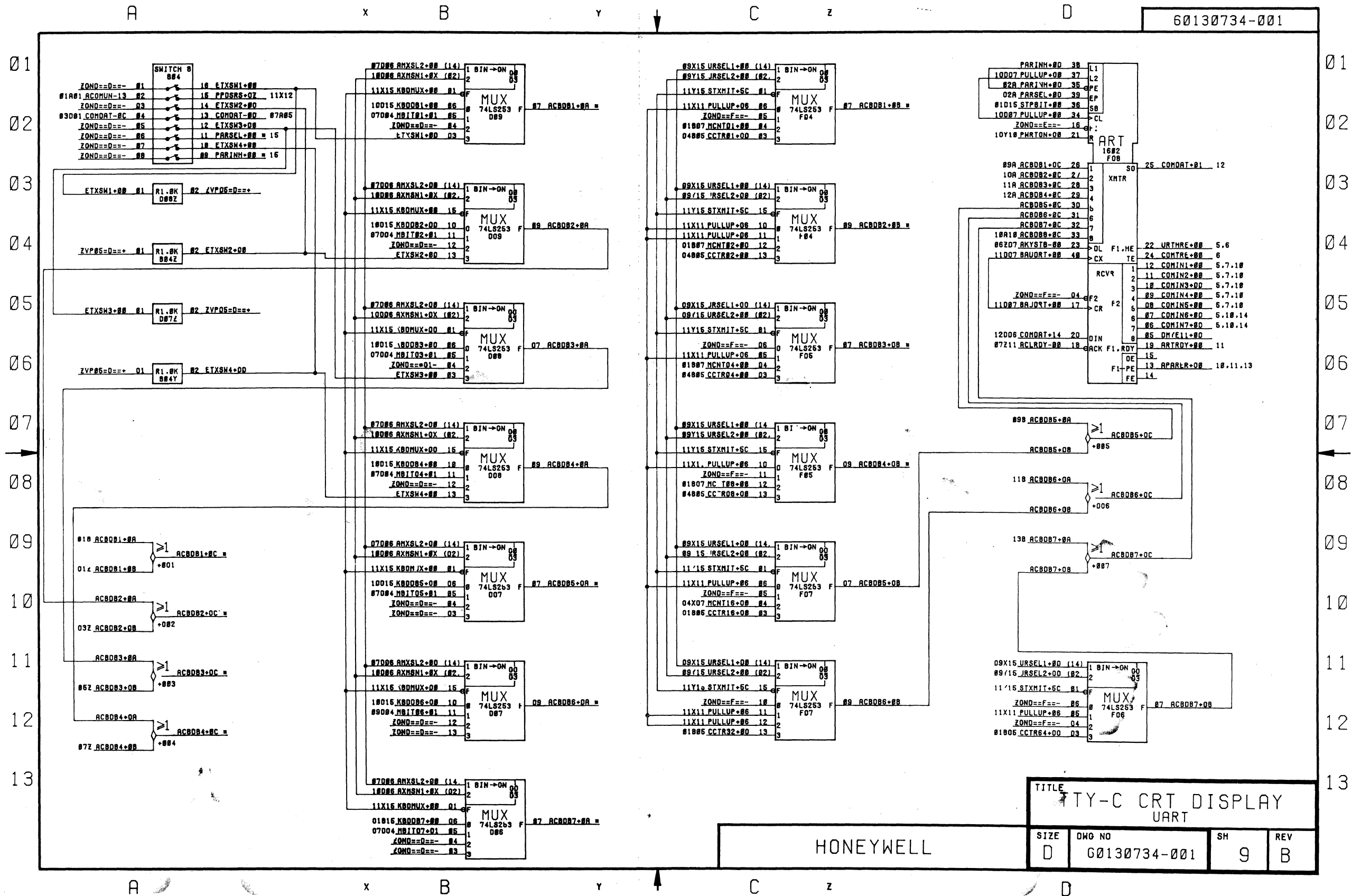

HONEYWELL PROPRIETARY AND CONFIDENTIAL

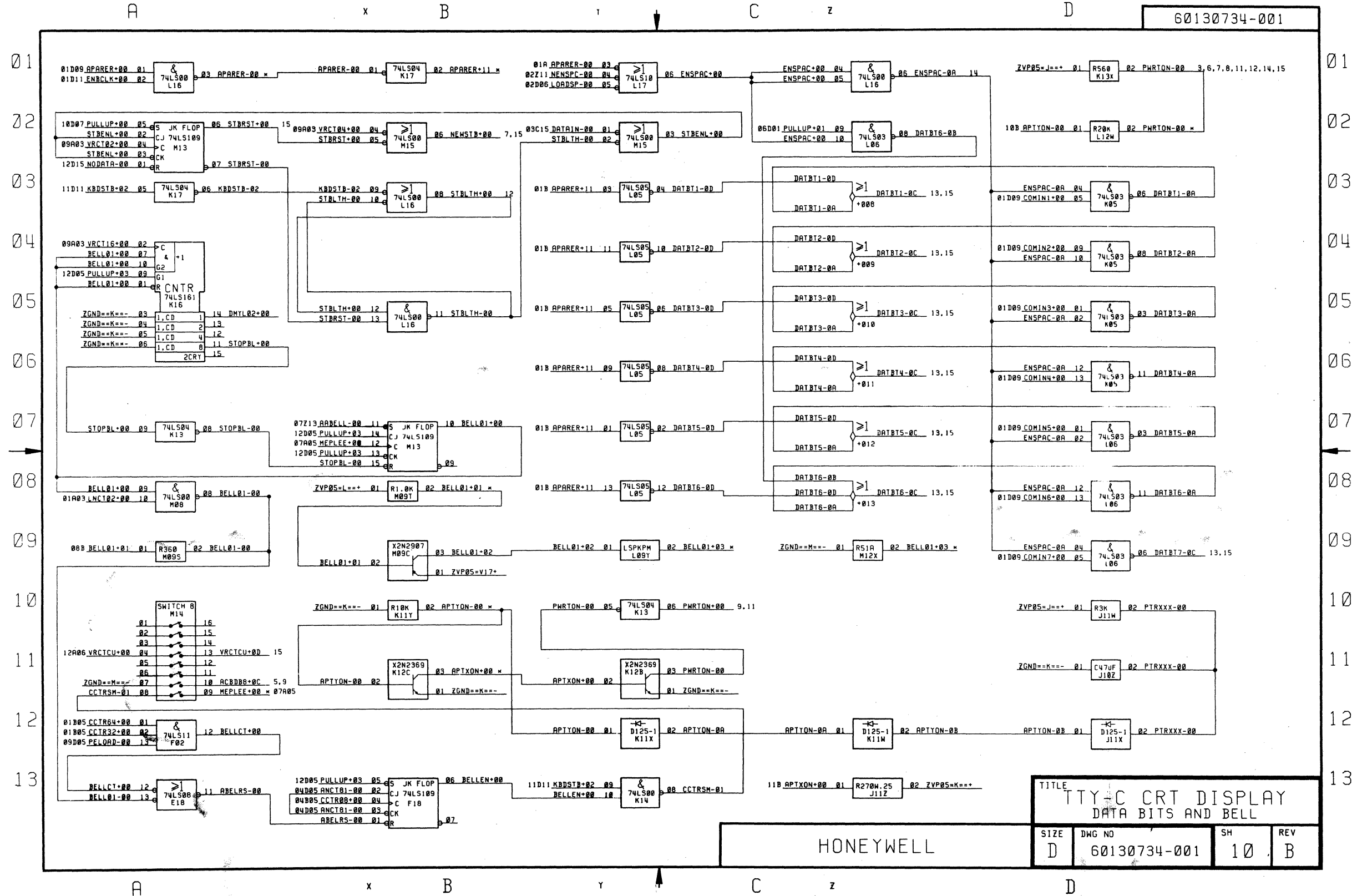



60130734-001

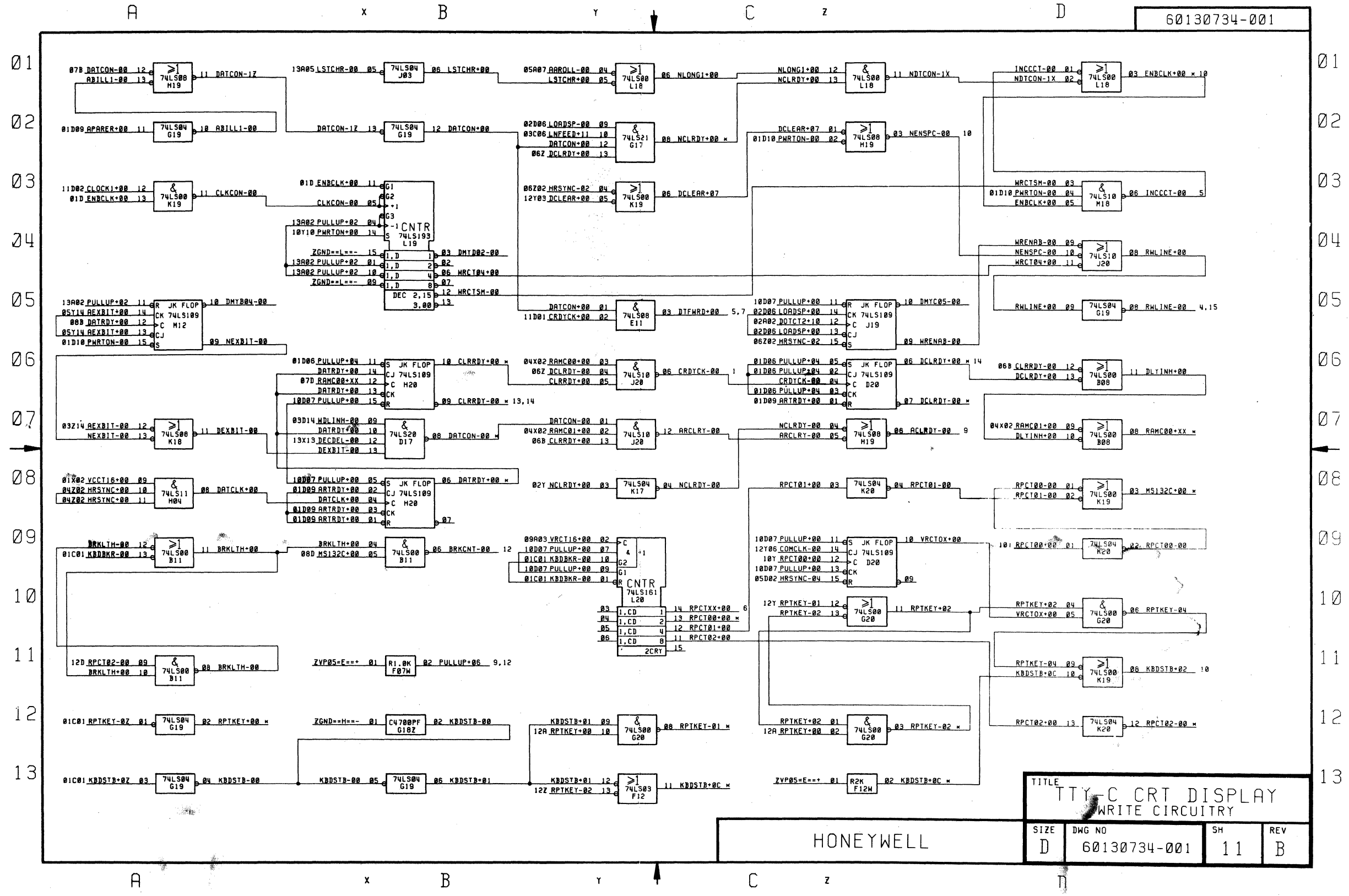

TITLE  
 TTY-C CRT DISPLAY  
 WRITE CIRCUITRY

|           |                        |          |          |
|-----------|------------------------|----------|----------|
| HONEYWELL |                        |          |          |
| SIZE<br>D | DWG NO<br>60130734-001 | SH<br>11 | REV<br>B |

60130734-001

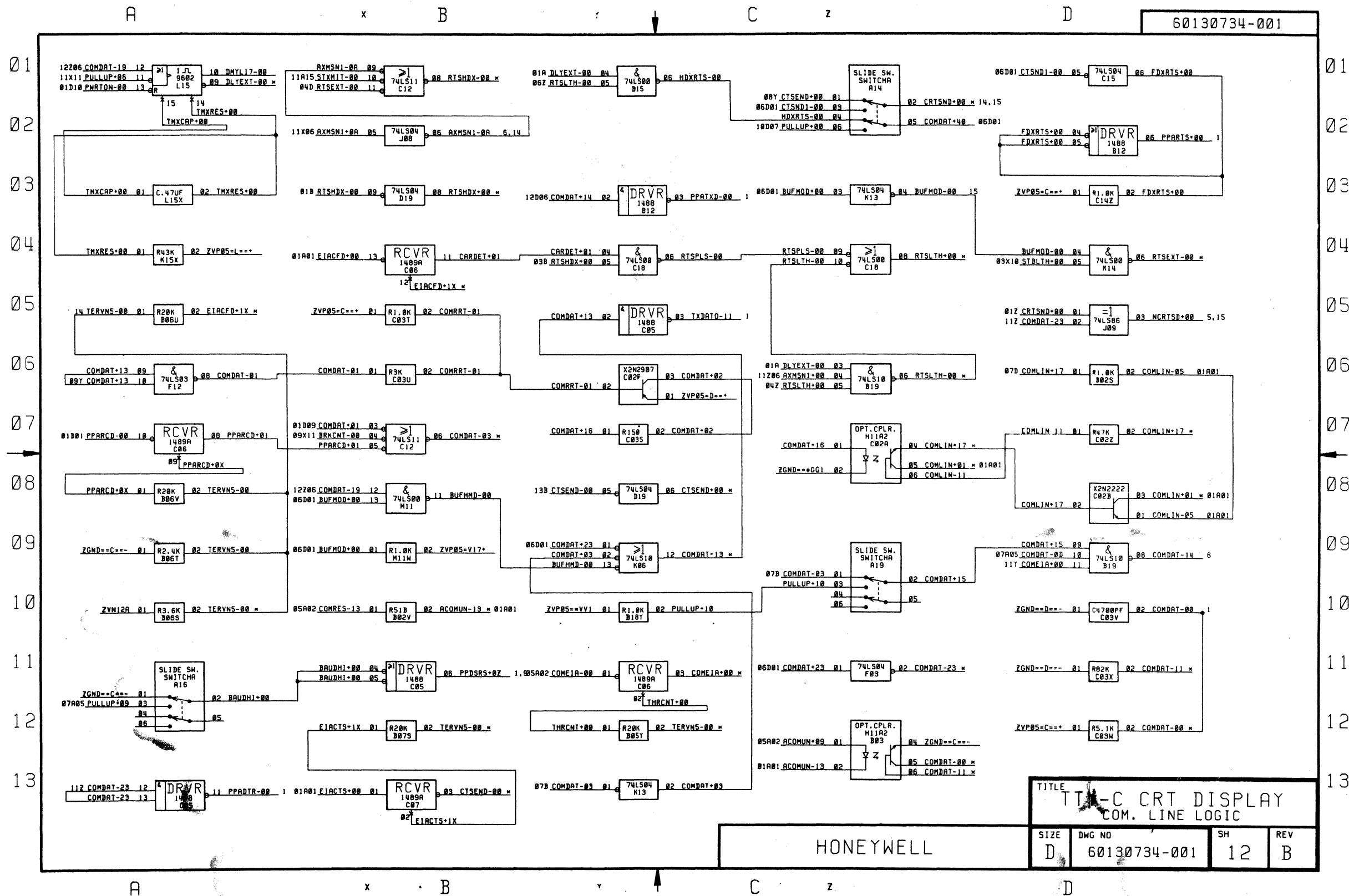

|                  |              |    |     |
|------------------|--------------|----|-----|
| TITLE            |              |    |     |
| TT-C CRT DISPLAY |              |    |     |
| COM. LINE LOGIC  |              |    |     |
| SIZE             | DWG NO       | SH | REV |
| D                | 60130734-001 | 12 | B   |

HONEYWELL

60130734-001

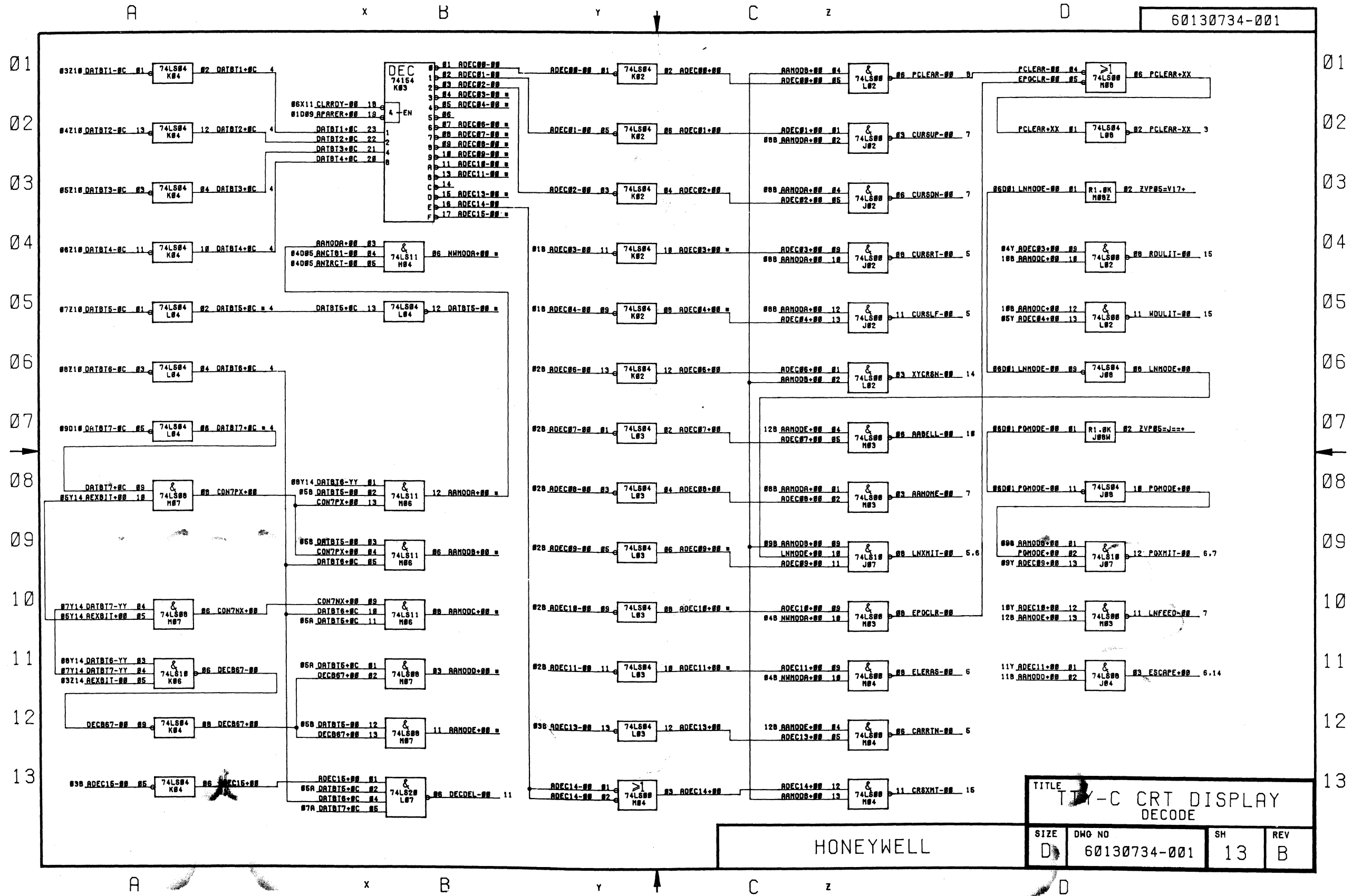

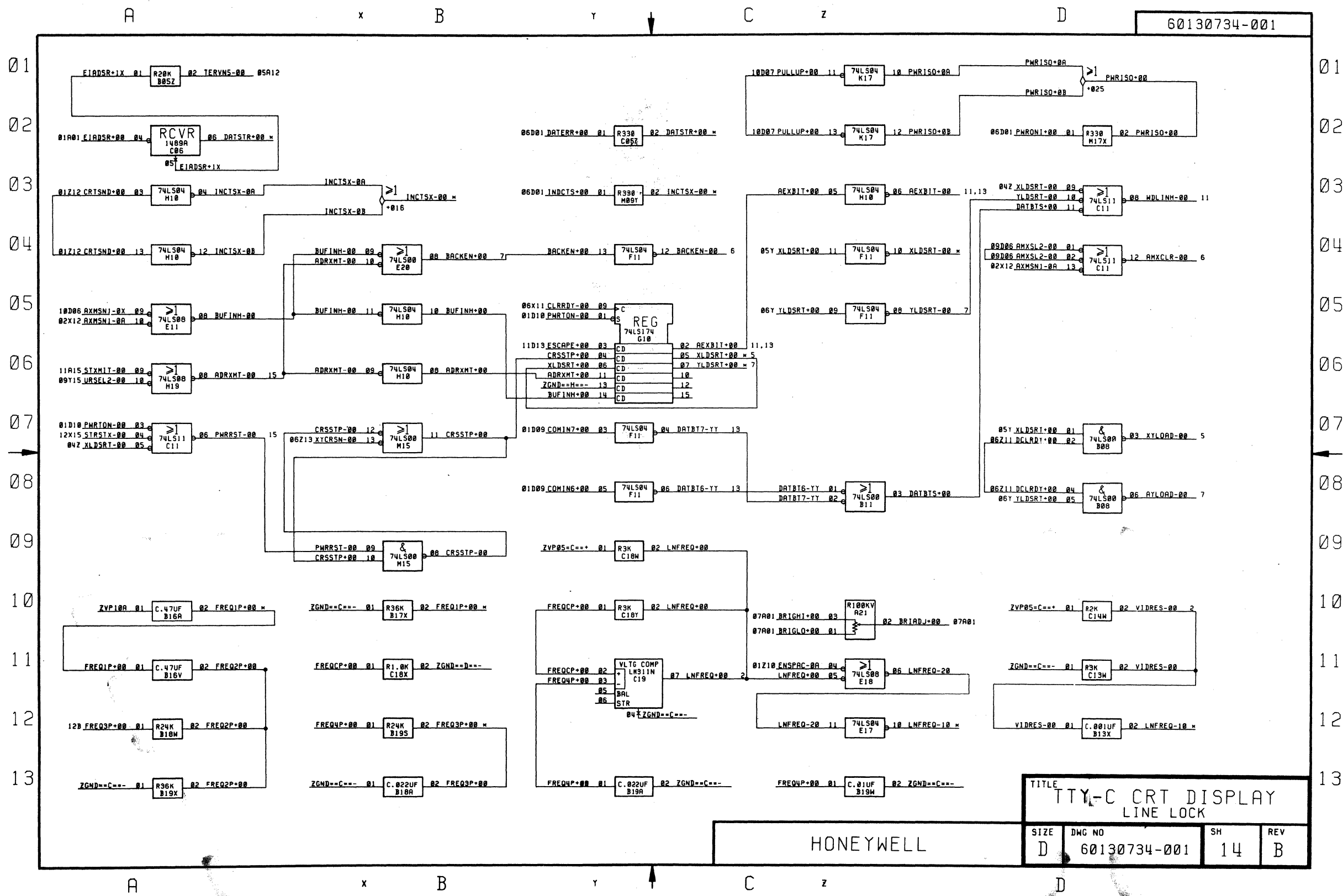

60130734-001

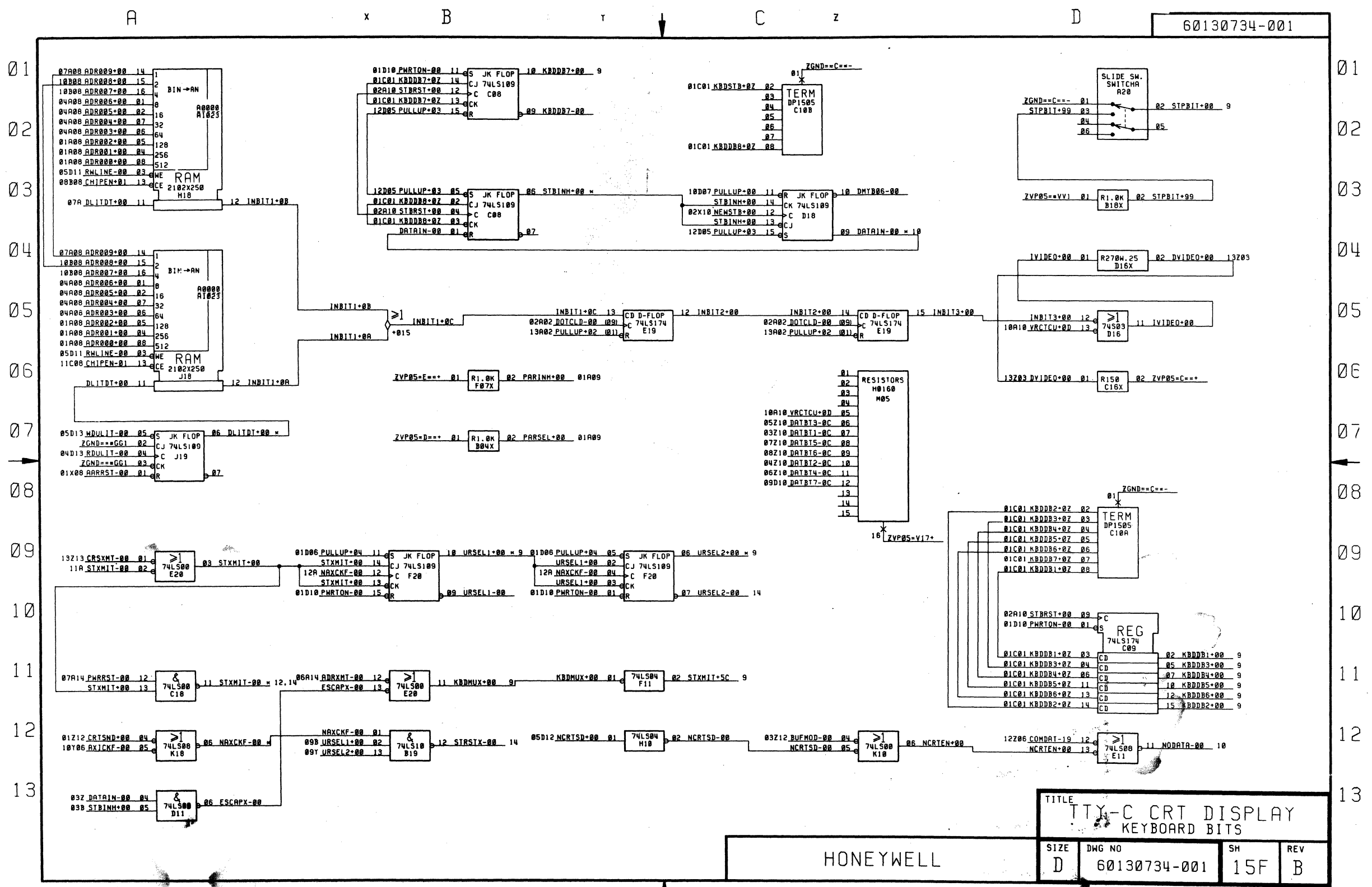

USERS' REMARKS FORM

TITLE: \_\_\_\_\_

DOC. PART NO. \_\_\_\_\_

DATED \_\_\_\_\_

ERRORS NOTED:

—  
Fold

SUGGESTIONS FOR IMPROVEMENT:

—  
Fold

DATE \_\_\_\_\_

FROM: NAME \_\_\_\_\_

COMPANY \_\_\_\_\_ M/S \_\_\_\_\_

TITLE \_\_\_\_\_

ADDRESS \_\_\_\_\_

ZIP \_\_\_\_\_

CUT ALONG LINE

FIRST CLASS  
Permit No. 39531  
Waltham, Ma.



**Business Reply Mail**

NO POSTAGE STAMP NECESSARY IF MAILED IN THE UNITED STATES



POSTAGE WILL BE PAID BY

HONEYWELL INFORMATION SYSTEMS INC.  
200 SMITH STREET  
WALTHAM, MA. 02154

MAIL STATION 872A  
HARDWARE PUBLICATIONS, BILLERICA

**Honeywell**

# Honeywell

## Honeywell Information Systems

In the U.S.A.: 200 Smith Street, MS 486, Waltham, Massachusetts 02154  
In Canada: 2025 Sheppard Avenue East, Willowdale, Ontario M2J 1W5  
In Mexico: Avenida Nuevo Leon 250, Mexico 11, D.F.

FN66, Rev.