

MIC440 Explosion-protected Camera

MIC440



BOSCH

Operation Manual

english
français

MIC 440 Explosion-protected PTZ Camera		3
---	--	----------

english	Table of contents	4
---------	-------------------	---

français	Table des matières	67
----------	--------------------	----

Table of contents

1	Safety	6
1.1	About this Manual	6
1.2	Legal Information	6
1.3	Safety Precautions	6
1.4	Important Safety Instructions	7
1.5	Important Notices	8
1.6	Safety Information Specific to Explosion Protection	15
1.7	Customer Support and Service	17
2	Unpacking	18
2.1	Parts List	18
2.2	Additional Products Required	18
2.3	Additional Tools Required	19
3	Product Description	20
4	Installation of a MIC440 Camera	21
4.1	Mounting the Conduit Gland and Cable	21
4.2	PSU Installation and Setup in a Non-Hazardous Area	22
4.3	PSU Installation and Setup in a Hazardous Area	22
4.4	MIC Power Supply Unit Extension	24
5	Select the Mounting Location and Orientation	26
5.1	Mounting Location Overview	26
5.2	Select the Mounting Location	28
5.3	Select the Mounting Orientation	29
5.4	Install the Mounting Brackets	29
6	Mount the Camera	30
7	Earthing the Camera	31
8	Finalize Camera Mounting	32
9	Install the MIC (standard) PSU	33
9.1	MIC PSU Overview	33
9.2	About the MIC Shielded Composite Cable	33
9.3	Composite Cable Color-coding	34
9.4	Earth Link on PCB	35
9.5	Fuse Ratings	35
9.6	Alarm Inputs	36
9.7	Layout of MIC Power Supply Units (PSUs)	36
9.8	Installation Warnings and Prerequisites	38
9.9	Installation Instructions (Power Supply)	39
9.10	Commissioning the Camera with Heater Option Fitted	46
10	Fit the Sunshield (MIC440)	48
11	Connection	50
12	Configuration	51
12.1	Addressing the Camera	51
12.2	Configuring the Camera for Inverted Operation	51
13	Operation	52
14	Maintenance and Troubleshooting	60
14.1	Cleaning MIC440	61

15	Decommissioning	64
15.1	Transfer	64
15.2	Disposal	64
16	Technical data	65
17	Appendices	66
17.1	MIC440 Common Features by Protocol	66

1 Safety

1.1 About this Manual

This manual has been compiled with great care and the information it contains has been thoroughly verified. The text was complete and correct at the time of printing. Because of the ongoing development of products, the content of the manual may change without notice. Bosch Security Systems accepts no liability for damage resulting directly or indirectly from faults, incompleteness, or discrepancies between the manual and the product described.

1.2 Legal Information

Copyright

This manual is the intellectual property of Bosch Security Systems, Inc. and is protected by copyright. All rights reserved.

Trademarks

All hardware and software product names used in this document are likely to be registered trademarks and must be treated accordingly.

1.3 Safety Precautions

In this manual, the following symbols and notations are used to draw attention to special situations:



Danger!

High risk: This symbol indicates an imminently hazardous situation such as “Dangerous Voltage” inside the product. If not avoided, this will result in an electrical shock, serious bodily injury, or death.



Warning!

Medium risk: Indicates a potentially hazardous situation. If not avoided, this may result in minor or moderate injury.



Caution!

Low risk: Indicates a potentially hazardous situation. If not avoided, this may result in property damage or risk of damage to the unit.



Notice!

This symbol indicates information or a company policy that relates directly or indirectly to the safety of personnel or protection of property.

1.4 Important Safety Instructions

Read, follow, and retain all of the following safety instructions. Heed all warnings on the unit and in the operating instructions before operation.



Caution!

TO REDUCE THE RISK OF ELECTRIC SHOCK, DISCONNECT THE POWER SOURCE WHILE INSTALLING THE DEVICE.



Caution!

Installation must be made by qualified personnel and conform to ANSI/NFPA 70 (the National Electrical Code® (NEC)), Canadian Electrical Code, Part I (also called CE Code or CSA C22.1), and all applicable local codes. Bosch Security Systems, Inc. accepts no liability for any damages or losses caused by incorrect or improper installation.



Warning!

INSTALL EXTERNAL INTERCONNECTING CABLES IN ACCORDANCE TO NEC, ANSI/NFPA70 (FOR US APPLICATION) AND CANADIAN ELECTRICAL CODE, PART I, CSA C22.1 (FOR CAN APPLICATION) AND IN ACCORDANCE TO LOCAL COUNTRY CODES FOR ALL OTHER COUNTRIES. BRANCH CIRCUIT PROTECTION INCORPORATING A 20 A, 2-POLE LISTED CIRCUIT BREAKER OR BRANCH RATED FUSES ARE REQUIRED AS PART OF THE BUILDING INSTALLATION. A READILY ACCESSIBLE 2-POLE DISCONNECT DEVICE WITH A CONTACT SEPARATION OF AT LEAST 3 mm MUST BE INCORPORATED.



Warning!

ROUTING OF EXTERNAL WIRING MUST BE DONE THROUGH A PERMANENTLY EARTHED METAL CONDUIT.



Warning!

THE CAMERA MUST BE MOUNTED DIRECTLY AND PERMANENTLY TO A NON-COMBUSTIBLE SURFACE.



Warning!

Do not open the camera when a hazardous environment is present!

Use common-sense safety precautions, especially in situations where there could be risk of injury if any part of the assembly becomes detached and falls.

- Ensure that the unit case is properly earthed. If the product is likely to be struck by lightning, ensure that earth bonding connections are made correctly to the mounting of the base of the unit.
- Do not point the camera at the sun. Bosch Security Systems will not be liable for any damage to cameras that have been pointed directly at the sun.
- Before transporting, supply power to the camera and rotate the ball so that the window points toward the base. This will help to protect the wiper and the window during transit.

**Warning!**

Do not manually back drive the camera

The motor/gear head combinations used in the MIC cameras were designed to provide smooth pan/tilt movement of the camera during powered operation. The gear heads were not specifically designed to be manually “back-driven” under any circumstance.

Although it might be possible to do so on unpowered units, there is no guarantee that “back-driving” will be possible on every unit. Some units may even enter a “locked-up” mechanical state.

If the camera becomes “locked-up,” simply apply power to the camera. The pan/tilt functions of the camera should now operate properly.

**Warning!**

Moving parts!

Moving parts may result in risk of injury, therefore, the device should be mounted so that it is accessible only to the technician/installer.

1.5**Important Notices****Notice!**

This camera is intended to be used in explosive environments.



Accessories - Do not place this unit on an unstable stand, tripod, bracket, or mount. The unit may fall, causing serious injury and/or serious damage to the unit. Use only with mounting solutions specified by the manufacturer. When a cart is used, use caution and care when moving the cart/unit combination to avoid injury from tip-over. Quick stops, excessive force, or uneven surfaces may cause the cart/unit combination to overturn. Mount the unit per the installation instructions.

All-pole power switch - Incorporate an all-pole power switch, with a contact separation of at least 3 mm, into the electrical installation of the building. If it is needed to open the housing, use this all-pole switch as the main disconnect device for switching off the voltage to the unit.

Camera signal - Protect the cable with a primary protector if the camera signal is beyond 140 feet, in accordance with *NEC800 (CEC Section 60)*.

Coax grounding:

- Ground the cable system if connecting an outside cable system to the unit.
- Connect outdoor equipment to the unit's inputs only after this unit has had its grounding plug connected to a grounded outlet or its ground terminal is properly connected to a ground source.
- Disconnect the unit's input connectors from outdoor equipment before disconnecting the grounding plug or grounding terminal.
- Follow proper safety precautions such as grounding for any outdoor device connected to this unit.

Section 810 of the National Electrical Code, ANSI/NFPA No.70, provides information regarding proper grounding of the mount and supporting structure, grounding of the coax to a discharge unit, size of grounding conductors, location of discharge unit, connection to grounding electrodes, and requirements for the grounding electrode.

**Disposal**

Your Bosch product has been developed and manufactured using high-quality materials and components that can be reused.

This symbol means that electronic and electrical devices that have reached the end of their working life must be disposed of separately from household waste.

In the EU, separate collecting systems are already in place for used electrical and electronic products. Please dispose of these devices at your local communal waste collection point or at a recycling center.

Fuse rating - For security protection of the device, the branch circuit protection must be secured with a maximum fuse rating of 16A. This must be in accordance with *NEC800 (CEC Section 60)*.

Heat sources - Do not install unit near any heat sources such as radiators, heaters, or other equipment (including amplifiers) that produce heat.

Moving - Switch off power at the power supply before disconnecting the unit. Move the unit with care. Excessive force or shock may damage the unit.

Outdoor signals - The installation for outdoor signals, especially regarding clearance from power and lightning conductors and transient protection, must be in accordance with *NEC725 and NEC800 (CEC Rule 16-224 and CEC Section 60)*.

Permanently connected equipment - Incorporate a readily accessible disconnect device in the building installation wiring.

Power lines - Do not locate the camera near overhead power lines, power circuits, or electrical lights, nor where it may contact such power lines, circuits, or lights.

Video loss - Video loss is inherent to digital video recording; therefore, Bosch Security Systems cannot be held liable for any damage that results from missing video information. To minimize the risk of losing information, we recommend multiple, redundant recording systems, and a procedure to back up all analog and digital information.

Object and liquid entry - With the exception of the base connector, the camera can be exposed to non-corrosive liquids without damage. Never push objects into the base connector as this may damage the connection pins and prevent the camera from operating correctly.

Power sources - Use only the power source indicated in this manual/on the device label.

Ensure that the rating of current of the supply cable is adequate for the device. Before proceeding, disconnect the power from the cable to be installed into the device.

- For external-power-supplied devices, use only the recommended or approved power supplies.

- For limited power source devices, this power source must comply with EN 60950.

Substitutions may damage the device or cause fire or shock.

- For 24 VAC devices, voltage applied to the device's power input should not exceed $\pm 10\%$ (or 28 VAC). User-supplied wiring must comply with local electrical codes (Class 2 power levels).

Do not ground the supply at the terminals or at the device's power supply terminals.

- If unsure of the type of power supply to use, contact your dealer or local power company.

Lightning - For added protection during a lightning storm, or when leaving the device unattended and unused for long periods, unplug the device and disconnect the cable system. This will prevent damage to the device from lightning and power line surges.

Water - Do not install the camera power supply near water for example near a bathtub, washbowl or swimming pool. The power supplies have an IP65 rating and are suitable for outside installation; however, for security reasons, Bosch recommends that they are installed in a suitable equipment cabinet. The camera is sealed to IP68 and can be used safely in damp environments or outdoors, as long as the base cable connector is suitably sealed.

Ventilation - The camera is a completely sealed device and requires no special consideration as regards to ventilation.

Damage requiring service – Switch off power at the power supply before disconnecting the unit. Refer servicing to qualified service personnel whenever any damage to the device has occurred, such as:

- the power supply cord or plug is damaged;
- liquid has been spilled into the device;
- an object has fallen into the device;
- the device has been dropped, or its enclosure or the equipment cabinet in which it is located has been damaged;
- the device exhibits a distinct change in performance;
- the device does not operate normally when the user follows the operating instructions correctly

Servicing - Do not attempt to service this device yourself. Refer all servicing to qualified service personnel.



Warning!

These power supply units are NOT explosion-proof and must be installed outside of the hazardous environment.



Caution!

Use only the power supply specified for your specific model of camera.



Caution!

The MIC440 camera is designed for use with flammable gases and vapors covered by apparatus groups IIA, IIB and IIC and with temperature class T6. The product is certified for use within the ambient temperature range of -20 °C to +60 °C and must not be used outside this range.



Warning!

Bosch recommends connecting the cable to the unit before taking the unit for mounting on-site.



Caution!

Any junction box or enclosure used for mounting the power supply or separating cable cores MUST BE appropriately rated for the installation. MIC PSU enclosures are not Exd rated and must be placed inside a certified enclosure if installed within a hazardous area. For additional protection in hazardous area installations, suitable metal conduit must be used externally for the composite cable run to connect the power supply to the Exd conduit gland (not supplied) in the Deep Conduit Adapter (MIC-DCA).



Notice!

Bosch Security Systems does not recommend using the shielded composite cable for distances greater than 25 m between the MIC camera and the MIC power supply.



Warning!

To minimize the potential for corrosion on the housing, use only Bosch hardware and mounts.



Notice!

MIC cameras must be secured to one of the following surfaces:

- Concrete (Solid/Cast)
 - Concrete Masonry Unit (Concrete Block)
 - Brick (all types)
 - Metal (Steel/Aluminum, minimum 1/8-in. thick)
-



Caution!

Risk of lightning strikes

If the camera is installed in a highly exposed location where lightning strikes may occur, then Bosch recommends installing a separate lightning conductor within 0.5 m (1.6 ft) of the camera and at least 1.5 m (4.9 ft) higher than the camera. A good earth bonding connection to the camera housing itself will provide protection against damage from secondary strikes. The camera housing itself is constructed to cope with secondary strikes. If the correct lightning protection is applied, then no damage to the internal electronics or camera should result.



Warning!

Ensure not to damage the paint on the housing of the camera or the mount.



Warning!

The camera must be earthed / grounded to meet EMC immunity standards.



Caution!

The upright unit can be mounted either with the camera ball up or down. So that the picture from a camera installed with the camera ball down appears properly, rotate the camera tilt axis 180°. For more information, see *Configuring the Camera for Inverted Operation*, page 51.



Warning!

It is essential that the connections and the base of the camera are completely sealed from water ingress. Any water getting into the connector is liable to cause corrosion to the connector pins, leading to unreliable operation of the camera unit. This is especially imperative for a camera mounted in inverted orientation.

**Danger!****ELECTRICAL SHOCK HAZARD**

To reduce the risk of electrical shock, disconnect power before opening or working on any power supply unit. Power must be disconnected before replacing any fuse in the MIC PSU. Power supply units have power supplied whenever the power cord is inserted into the power source.

MIC PSUs have a separate internal shield covering the power cable input terminal block (HD1). Only suitably qualified persons should remove this shield and connect the mains power cable. The shield **MUST** be re-installed and fully secured before connecting the power.

The power supply cable shall have conductors of a maximum size of 12 AWG.

Branch circuit protection incorporating a 15 A, 2-pole, listed circuit breaker or branch rated fuses are required. A readily accessible 2-pole disconnect device with a contact separation of at least 3mm must be incorporated externally to the equipment.

**Warning!**

To meet UL standards and ratings, all external wires (power and I/O cabling) for installation applications to the device **must be** routed separately through different permanently earthed metal conduits (not supplied).

**Caution!**

Except for the Earth Link, heater links, and applicable fuses, the MIC PSUs have no user-adjustable parts. MIC cameras have no user-serviceable parts.

**Caution!**

Bosch recommends using an uninterruptible power supply (UPS) in connection with a MIC camera/PSU installation.

**Notice!**

To maintain the IP rating of the power supply enclosure, install only listed or recognized conduit hubs or fittings with the same environmental rating as the enclosure in compliance with the installation instruction of the hub or fitting.

**Notice!**

Refer to the *MIC Series Power Supply Installation Manual* included with the PSU for full details on installing a MIC Series PSU and connecting to a MIC Camera.

**Notice!**

Do not connect MIC IR units to a MIC PSU with the heater option enabled as this can damage the cameras. Ensure that an IR power supply is used with a MIC IR camera unit. Heaters are available for MIC612 cameras only.

**Notice!**

Use only UL-listed liquid tight strain reliefs for conduits to the power supply box to ensure that water cannot enter the box. You must use watertight conduits and fittings to meet NEMA 6P or to maintain IP68 standards.



Notice!

Do not stretch or cut, or otherwise disturb, the earth core cable (shown in the figure below) to the inside of the lid and to the earth termination post.



Caution!

Only installations with conduit meet UL standards. If you choose to use a power cord without conduit (not recommended), fit the 1/2 in. NPT cable gland (supplied) in place of the blanking plug. Note: It is easier to fit the power cord through the cable gland outside of the enclosure, and then attach the gland to the enclosure. Ensure that the cable glands have sufficient room to allow for the cables to enter (approximately 60 mm on either side of the enclosure).



Caution!

DO NOT REMOVE the lid from the camera, and do not back drive the pan or tilt axis manually. Doing so will void the warranty. Back driving may also strip teeth off the internal gears.



Caution!

The Biphase shield must be connected to the head end only.



Notice!

This is a **class A** product. In a domestic environment this product may cause radio interference, in which case the user may be required to take adequate measures.



Notice!

Ce produit est un appareil de **Classe A**. Son utilisation dans une zone résidentielle risque de provoquer des interférences. Le cas échéant, l'utilisateur devra prendre les mesures nécessaires pour y remédier.

FCC & ICES Information

(U.S.A. and Canadian Models Only)

This device complies with part 15 of the FCC Rules. Operation is subject to the following conditions:

- this device may not cause harmful interference, and
- this device must accept any interference received, including interference that may cause undesired operation.

NOTE: This equipment has been tested and found to comply with the limits for a **Class A** digital device, pursuant to Part 15 of the FCC Rules and ICES-003 of Industry Canada. These limits are designed to provide reasonable protection against harmful interference when the equipment is operated in a **commercial environment**. This equipment generates, uses, and radiates radio frequency energy and, if not installed and used in accordance with the instruction manual, may cause harmful interference to radio communications. Operation of this equipment in a residential area is likely to cause harmful interference, in which case the user will be required to correct the interference at his expense.

Intentional or unintentional modifications, not expressly approved by the party responsible for compliance, shall not be made. Any such modifications could void the user's authority to operate the equipment. If necessary, the user should consult the dealer or an experienced radio/television technician for corrective action.

The user may find the following booklet, prepared by the Federal Communications Commission, helpful: How to Identify and Resolve Radio-TV Interference Problems. This booklet is available from the U.S. Government Printing Office, Washington, DC 20402, Stock No. 004-000-00345-4.

UL Disclaimer

Underwriter Laboratories Inc. ("UL") has not tested the performance or reliability of the security or signaling aspects of this product. UL has only tested fire, shock and/or casualty hazards as outlined in Standard(s) for Safety for Information Technology Equipment, UL 60950-1 . UL Certification does not cover the performance or reliability of the security or signaling aspects of this product.

UL MAKES NO REPRESENTATIONS, WARRANTIES, OR CERTIFICATIONS WHATSOEVER REGARDING THE PERFORMANCE OR RELIABILITY OF ANY SECURITY OR SIGNALING-RELATED FUNCTIONS OF THIS PRODUCT.

1.6 Safety Information Specific to Explosion Protection



Warning!

DO NOT OPEN PRODUCT HOUSING!

No repairs requiring opening the product housing are permitted.

Failure to observe this precaution will void the certification and the warranty.

The product is certified for use within the ambient temperature range of -20 °C to +60 °C and must not be used outside this range.

The certification of this equipment depends upon the maintenance of the flamepaths and the use of the following materials in the construction of exposed parts: Aluminum (BS-EN755 1997 6082T6); Stainless Steel (BS-EN10088 No.1.4404). The maximum constructional gaps (Ic) of the cylindrical flamepaths are less than that required by Table A of EN 60079-1:2007, as detailed below:

Flamepath	Maximum Gap (mm)
Between the tilt center bore and tilt bearing housing shaft (2 off)	0.089
Between the yoke arm bore and tilt resolver shaft	0.061
Between the yoke arm bore and yoke arm blanking cap shaft	0.061
Between the yoke arm bore and yoke spigot shaft	0.061
Between the pan body top bore and yoke spigot shaft (2 off)	0.061
Between the upper cover bore and wiper motor mount shaft	0.060
Between the wiper motor mount bore and base flange shaft	0.100

The pan body to pan body top are to be secured with cap head M5 - 0.8 x 10 mm long S316 stainless steel grade A4/70 special fasteners.



Warning!

Take suitable precautions if camera may come in contact with aggressive substances

If the equipment is likely to come in contact with aggressive substances (for example, acidic liquids or gases that may attack metals, or solvents that may affect polymeric materials), then the user is responsible for taking suitable precautions that prevent it from being adversely affected, thus ensuring that the type of protection provided by the equipment is not compromised. "Suitable precautions" include regular checks as part of routine inspections or establishing from the material's datasheets that it is resistant to specific chemicals.

The camera is designed for use with flammable gases and vapors covered by apparatus groups IIA, IIB, and IIC, and with temperature classes T1 to T6.

Units must carry the following certification marking: **SIRA05ATEX1300X Exd IIC T6 Ta -20°C to +60°C Gb.**

EC Directives

This MIC camera complies with the following EC directives:

- ATEX Directive (2014/34/EU)
- EMC Directive (2014/30/EU)
- Machinery Directive (2006/42/EC)
- Low Voltage Directive (2014/35/EU)
- RoHS (Restriction of Hazardous Substances) 2011/65/EC

- WEEE (Waste Electrical and Electronic Equipment) 2002/96/EC

1.7 Customer Support and Service

If this unit needs service, contact the nearest Bosch Security Systems Service Center for authorization to return and shipping instructions.

Service Centers

USA

Telephone: 800-366-2283 or 585-340-4162

Fax: 800-366-1329

Email: cctv.repair@us.bosch.com

Customer Service

Telephone: 888-289-0096

Fax: 585-223-9180

Email: security.sales@us.bosch.com

Technical Support

Telephone: 800-326-1450

Fax: 585-223-3508 or 717-735-6560

Email: technical.support@us.bosch.com

Repair Center

Telephone: 585-421-4220

Fax: 585-223-9180 or 717-735-6561

Email: security.repair@us.bosch.com

Canada

Telephone: 514-738-2434

Fax: 514-738-8480

Europe, Middle East & Africa Region

Please contact your local distributor or Bosch sales office. Use this link:

<http://www.boschsecurity.com/startpage/html/europe.htm>

Asia Pacific Region

Please contact your local distributor or Bosch sales office. Use this link:

http://www.boschsecurity.com/startpage/html/asia_pacific.htm

More Information

For more information please contact the nearest Bosch Security Systems location or visit www.boschsecurity.com

2 Unpacking

- This equipment should be unpacked and handled with care. Check the exterior of the packaging for visible damage. If an item appears to have been damaged in shipment, notify the shipper immediately.
- Verify that all the parts listed in the Parts List below are included. If any items are missing, notify your Bosch Security Systems Sales or Customer Service Representative.
- Do not use this product if any component appears to be damaged. Please contact Bosch Security Systems in the event of damaged goods.
- The original packing carton is the safest container in which to transport the unit and must be used if returning the unit for service. Save it for possible future use.



Caution!

Take extra care lifting or moving MIC440 cameras because of their weight (15.5 kg (34.17 lb)).

2.1 Parts List

Quantity	Part
1	MIC440 with Exd DCA attached
1	Quick Installation Guide
1	MIC Series 440 Installation Manual
1	USB to RS-485 converter kit
4	M3 x 25 mm stainless screws
1	Nebar gasket

2.2 Additional Products Required

Mounting accessories are sold separately by Bosch. (Refer to the chapter Product Description for a list.) Users must supply all wiring/cabling for power, video, and telemetry.

The following table lists additional products, sold separately by Bosch, required to operate each MIC camera:

Quantity	Product	Part Number	Size
1 per camera	Shielded Composite Cable for MIC cameras (See the model numbers and lengths at right.)	MIC-CABLE-2M	2 m
		MIC-CABLE-10M	10 m
		MIC-CABLE-20M	20 m
		MIC-CABLE-25M	25 m
Quantity	Product	Part Number	
1 per camera	Power Supply Unit (PSU) for MIC cameras	MIC-240PSU-2, MIC-115PSU-2, MIC-24PSU-2	



Warning!

These power supply units are NOT explosion-proof and must be installed outside of the hazardous environment.

2.3

Additional Tools Required

The following table lists additional tools (not supplied by Bosch) that are or may be required to install a MIC camera:

Quantity	Part
1	13 mm wrench for the mounting bolts
1	3 mm screwdriver for the terminal blocks in the MIC PSU
1	8 mm screwdriver for captive screws for the MIC PSU enclosure
1	Roll of PTFE tape

3 Product Description

MIC Series 440 cameras are high-performance, weatherproof, ruggedized, fully functional day/night PTZ cameras that have been designed to offer a reliable, robust, and high-quality surveillance solution for extreme security applications.

MIC440 models have a 18x or 36x optical zoom (12x digital) and flexible mounting options (upright or inverted) to achieve the perfect field of view.

MIC440 cameras meet the requirements of ATEX Directive 2014/34/EU Exd IIC T6 and CSA Class I, Division 1, Groups CD, Class II, Division 1, Groups EFG, T6 for safe use in explosive atmospheres such as those found in oil, gas, chemical processing sites, and petrochemical refineries.

Precision-engineered to exacting standards, MIC cameras offer numerous benefits over traditional dome and PTZ cameras. Rated to an industry-leading IP68, Type 4X, the compact, vandal-resistant, cast aluminum camera housing is pre-treated and then painted with polyester powder coat paint (black, white, or grey). Brushless motor technology ensures ultra-reliable operation with full 360° continuous pan and up to 320° tilt control. The optically perfect, flat viewing window and integrated wiper ensure that razor-sharp images are captured in even the most demanding environmental conditions.

A long-life silicone wiper blade mounted on a spring-loaded arm is standard on all MIC cameras.

The following table identifies the optional accessories for MIC cameras. Refer to the datasheets of each accessory for details. Some accessories may not be available in all regions.

Accessories	Description
MIC-SCA	Shallow Conduit Adapter
MIC-CMB	Corner Mount Bracket
MIC-PMB	Pole Mount Bracket
MIC-WMB	Wall Mount Bracket
MIC-SPR	Spreader Plate
MIC-ALM	Alarm and washer pump drive card for non-IR PSU; 8 inputs.
MIC-WKT	Washer kit, containing mounting bracket, nozzle, and washer pump drive card.
MIC-BP4	Bosch Biphase converter card for MIC power supplies with an available expansion slot.
MIC440SUNSHIELD	A two-part plastic sunshield to provide additional protection in sunny climates for MIC cameras Comes with stainless steel bosses, washers, and retaining screws.

4 Installation of a MIC440 Camera

This chapter provides an overview for the installation of a MIC440 camera.



Caution!

The MIC440 camera is designed for use with flammable gases and vapors covered by apparatus groups IIA, IIB and IIC and with temperature class T6. The product is certified for use within the ambient temperature range of -20 °C to +60 °C and must not be used outside this range.

While a MIC440 camera is certified for installation in a hazardous area, its power supply unit (PSU) is not. The PSU itself can be installed in either a non-hazardous area or in a hazardous area. If installed in a hazardous area, the PSU must be placed inside a certified enclosure that is certified for use in hazardous areas.



Warning!

ROUTING OF EXTERNAL WIRING MUST BE DONE THROUGH A PERMANENTLY EARTHED METAL CONDUIT.

4.1 Mounting the Conduit Gland and Cable

The MIC composite cable (8 mm) required to connect the MIC440 to its power supply consists of two pairs (24AWG) plus 4 cores of (22 AWG), 2 cores of (24 AWG), and one coax core for the video signal to a maximum distance of 25 m.



Warning!

Bosch recommends connecting the cable to the unit before taking the unit for mounting on-site.

To mount the conduit gland and cable, follow these steps:

1. Remove the 4 x M8 Hexagon bolts holding the conduit adapter (DCA) to the MIC440 unit. Remove the DCA.
2. Fit the unterminated ends of the composite cable through the 20 mm threaded gland hole in the DCA. Allow approximately 100 mm of free cable on the inside to connect to the 12-way cable connector.
3. Screw the Exd conduit gland into the DCA, maintaining approximately 100 mm of cable on the inside of the DCA to enable the cable connector to be inserted freely into the MIC unit base connector.
4. Connect the 12-way cable connector into the matching connector in the base of the MIC unit.
5. Ensure that the connector is fitted properly in the camera's integral plug. Turn the socket thread ring approximately two and a half turns to fasten the two halves of the connectors together properly.
6. Bolt the DCA onto the MIC440 unit; tighten the 4 x M8 hexagon bolts.
7. Ensure that there are no trapped cables.
8. Ensure that there is some slack cable in the DCA, then tighten and seal the Exd barrier gland per the instructions included with the gland. The unit with the cable tail is now ready for on-site installation.

4.2 PSU Installation and Setup in a Non-Hazardous Area

The figure below illustrates an installation of a MIC PSU for MIC440 in a non-hazardous area. Note that the camera itself is installed in a hazardous area.

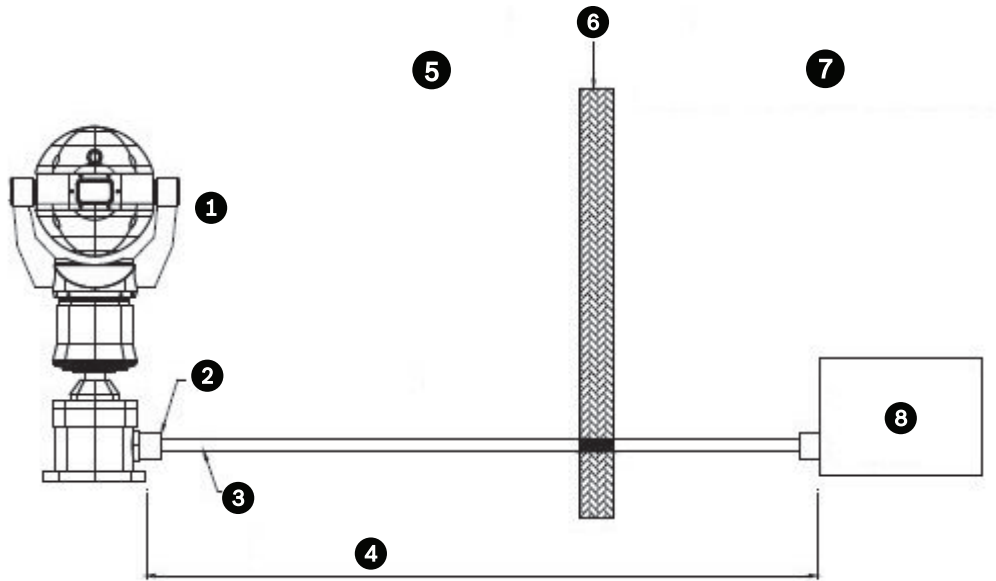

Figure 4.1: Installation of MIC PSU in Non-Hazardous Area

1	MIC440 camera
2	Exd conduit gland
3	Composite cable inside metal conduit
4	Distance of 25 m maximum
5	Hazardous area
6	Exd Barrier
7	Non-hazardous Area
8	Standard MIC PSU

4.3 PSU Installation and Setup in a Hazardous Area



Caution!

Any junction box or enclosure used for mounting the power supply or separating cable cores **MUST BE** appropriately rated for the installation. MIC PSU enclosures are not Exd rated and must be placed inside a certified enclosure if installed within a hazardous area. For additional protection in hazardous area installations, suitable metal conduit must be used externally for the composite cable run to connect the power supply to the Exd conduit gland (not supplied) in the Deep Conduit Adapter (MIC-DCA).

Installation of the PSU within a hazardous area must have the standard PSU enclosure placed inside an appropriate certified enclosure and four (4) Exd conduit glands (NOT supplied). The power supply PCB is usually re-housed, by a third party company, within an Exd enclosure which is then factory certified and shipped to site. Follow all manufacturers' instructions when installing a third party Exd enclosure.

The figure below illustrates a typical installation of both a MIC440 and a MIC PSU in a hazardous area. Note that the PSU is installed inside an enclosure that is certified for use in hazardous areas.

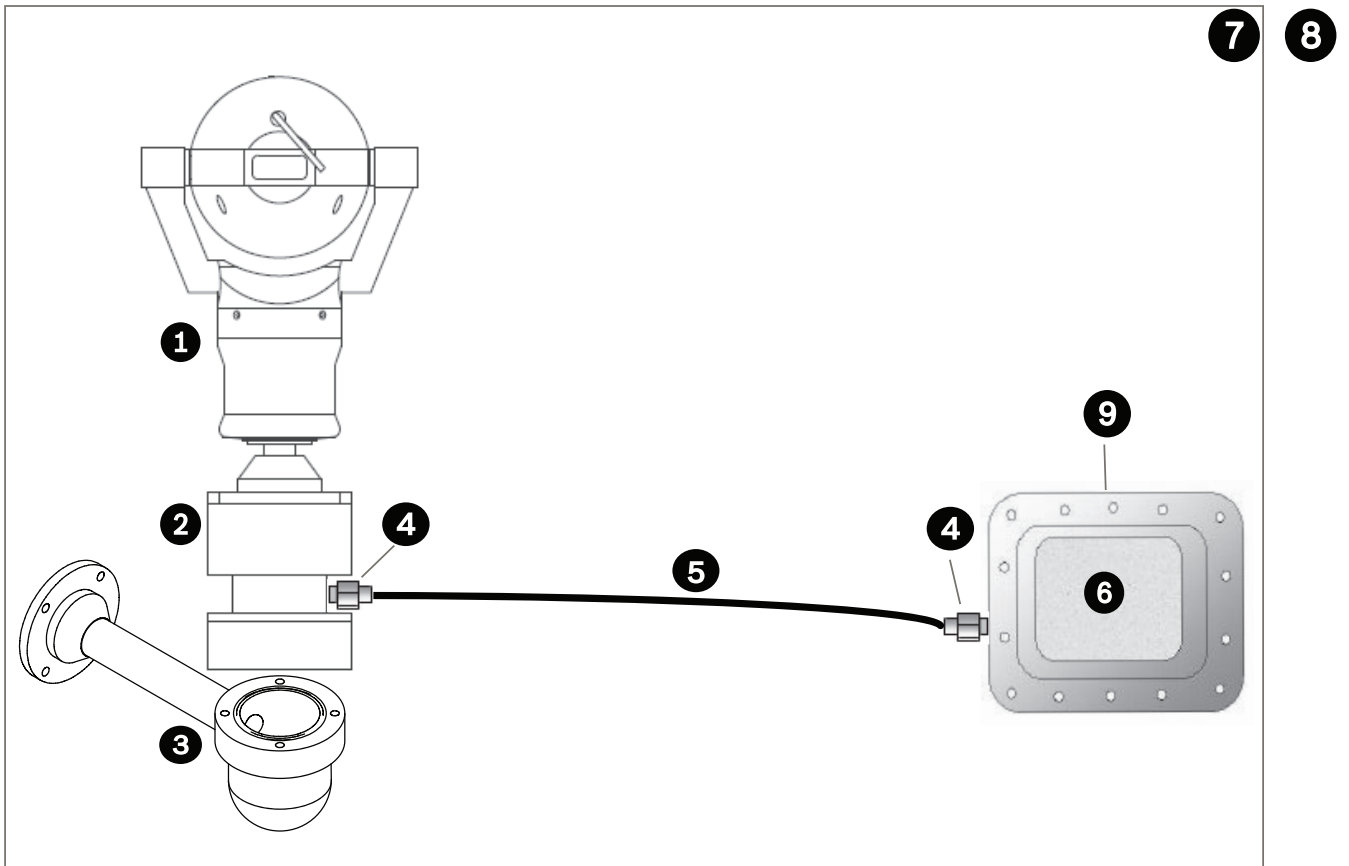

Figure 4.2: Installation of MIC PSU in Hazardous Area

No.	Description
1	MIC440 camera
2	MIC440 DCA
3	MIC Wall Mount Bracket (not supplied)
4	Exd conduit gland Exd Barrier Gland (not supplied; to be specified by installer to match incoming conduit)
5	MIC composite cable (length to be specified; 25 m maximum) inside metal conduit (not supplied)
6	MIC PSU
7	Hazardous area
8	Non-Hazardous area
9	Exd Enclosure certified for hazardous areas (not supplied)

4.4 MIC Power Supply Unit Extension

Users can extend the distance between their MIC camera and the MIC PSU by using two junction boxes (user-supplied). The boxes must be weatherproof or explosion-proof, depending on the model and the physical location of the box. The second junction box is required to reduce the size of the cable and to reduce the amount of conduit connections to the MIC PSU.

All cables used in hazardous zones must be Ex-rated, or must be installed inside permanently earthed metal conduit with Ex-rated fittings. See the table below for the maximum distance and wire gauge recommended for each camera. The maximum distance is the distance between the two user-supplied junction boxes.

Wire Gauge	18 AWG	16 AWG	14 AWG	12 AWG
Maximum Distance in Meters (feet)	46 (151)	73 (240)	116 (381)	185 (606)

Maximum Watts, MIC440 = 45.

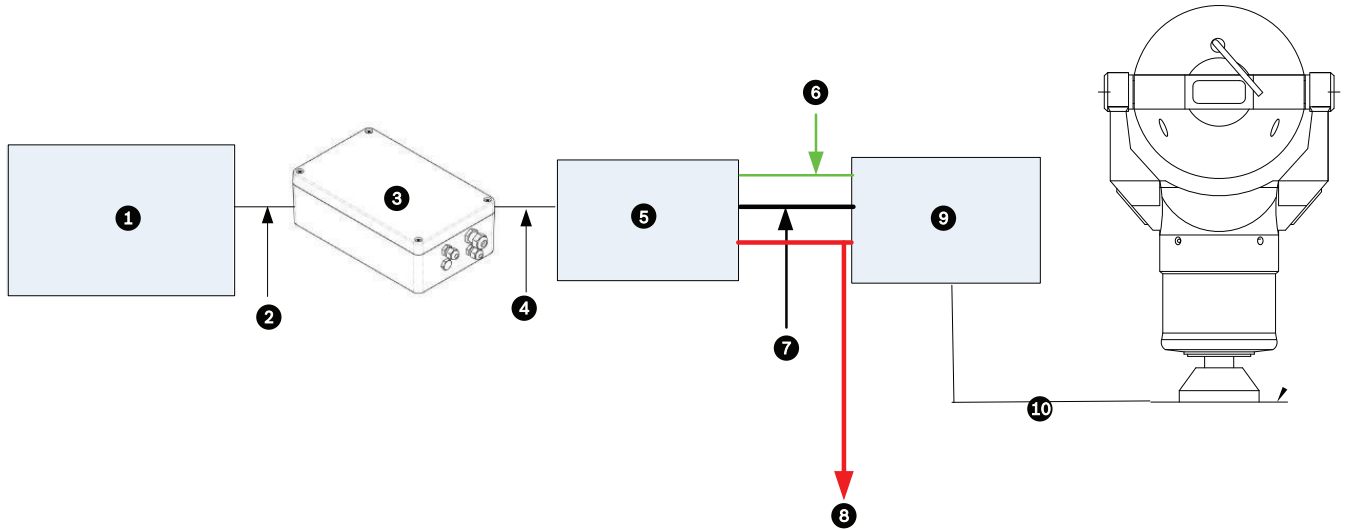

Figure 4.3: MIC PSU Extension with two (2) user-supplied junction boxes (weatherproof or explosion-proof, depending on model and physical location)

1	Head-end control system
2	Standard cables and power
3	MIC PSU
4	Standard MIC composite cable (2 meters MAXIMUM)* inside metal conduit
5	First user-supplied Junction Box (weatherproof or explosion-proof). See the Caution boxes at the beginning of the subchapter.)
6	RG59U Coax
7	RS-485 (2- or 4-wire shielded twisted pair with ground)
8	Power wires, which control the maximum distance. See the table below for limitations.
9	Second user-supplied Junction Box (weatherproof or explosion-proof). See the Caution boxes at the beginning of the subchapter.) This second box is required to reduce the size of the cable and to reduce the amount of conduit connections to the MIC PSU.
10	Standard MIC composite cable inside metal conduit

5 Select the Mounting Location and Orientation

5.1 Mounting Location Overview

MIC Series cameras are designed for easy installation in various locations such as directly onto buildings and dedicated CCTV poles. Bosch sells a complete series of mounting brackets designed to allow the camera to achieve the optimal field of view.

The most common type of mounting location is the top of a dedicated CCTV pole that provides a robust mounting platform that minimizes camera motion and typically has a large base cabinet for mounting ancillary equipment such as power supplies.

The camera can also be mounted on the side of a lamp post, pole, or similar column using the Pole Mount Bracket (MIC-PMB). Be aware that lamp posts can often be subject to movement and are not suitable platforms in all conditions or for all applications.

Other locations for mounting the camera include the top of a building, the side (wall) of a building, the corner of a building, and under the eave of a building.

Surveillance cameras are susceptible to vibrations caused by wind or vibrations emanating from the medium to which the camera is attached. Cameras attached to a pole, roof, or bridge are especially vulnerable. Bosch offers the following recommendations to stabilize your camera and to decrease the effects of vibration on transmitted images.

Pole and mast mounts

- Use a pole designed for CCTV cameras.
- Do not use a tapered pole.
- Do not use a pole that has signs or other equipment attached.
- Consult EPA rating/Wind load data to select an appropriate pole.

Roof mounts

- Mount the camera in the most stable location on the roof.
- Avoid locations affected by vibrations such as those caused by a rooftop air conditioner.
- Use guy wires to stabilize the camera against strong winds.

Extreme mount applications

Unique camera mounting applications that are impacted by extreme high winds, heavy traffic, or other conditions may require additional measures to stabilize the camera. Contact a manufacturer that specializes in passive vibration suppression using either damping or isolation.

The three figures directly below illustrate the arrangement of mounting brackets for installing a MIC camera. The camera (not shown) is attached to the bowl of the MIC-WMB.

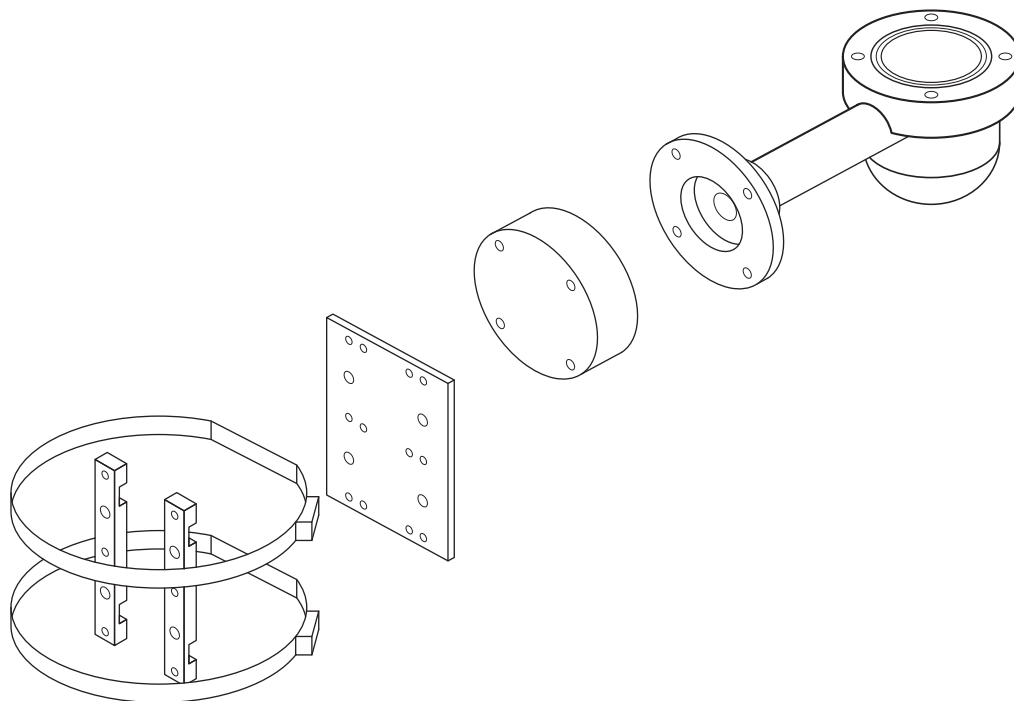

Figure 5.1: Typical pole mount (from left: Pole Mount Bracket (MIC-PMB) [2 mounting blocks, 2 pole bands, and 1 mounting plate], Shallow Conduit Adapter (MIC-SCA), and Wall Mount Bracket (MIC-WMB))

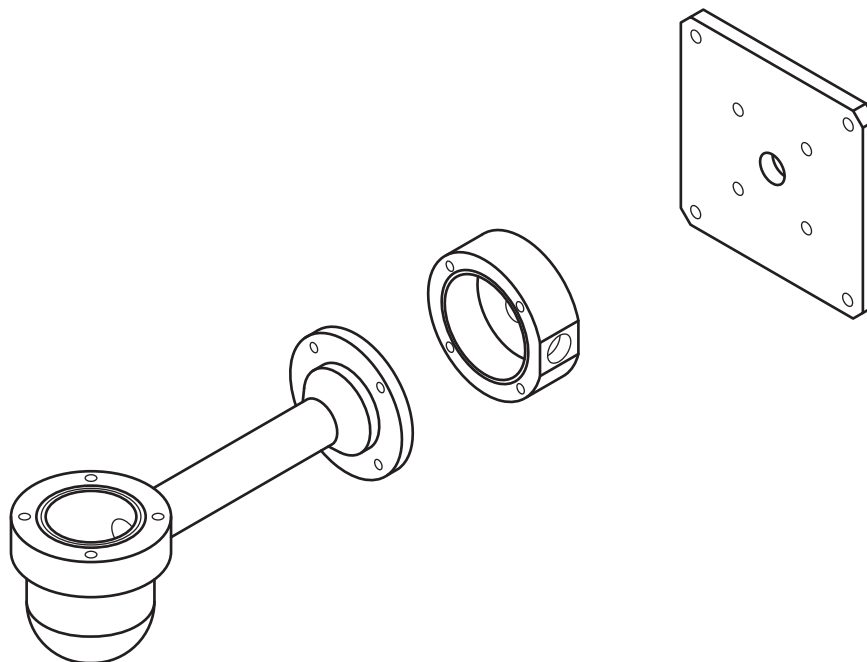

Figure 5.2: Typical wall mount (from left: Wall Mount Bracket (MIC-WMB), Shallow Conduit Adapter (MIC-SCA), and Spreader Plate (MIC-SPR))

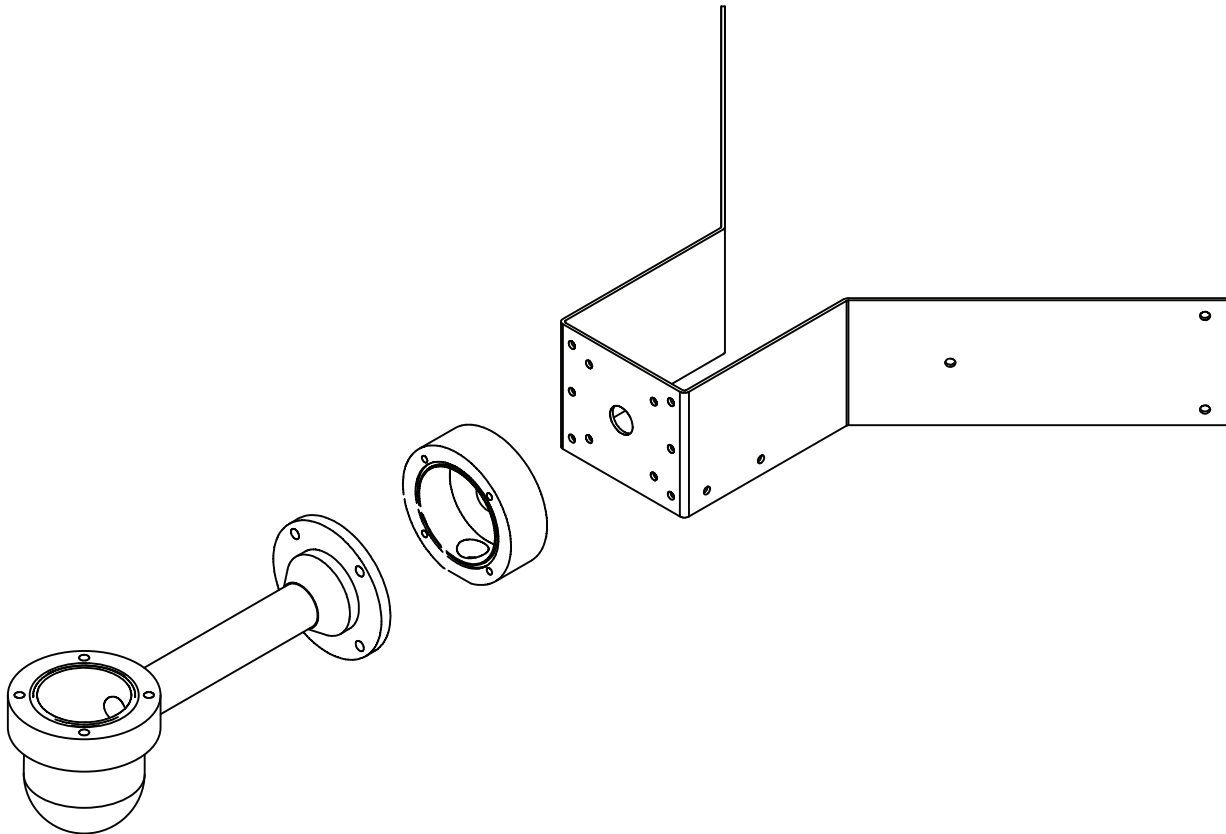

Figure 5.3: Typical corner mount (from left: Wall Mount Bracket (MIC-WMB), Shallow Conduit Adapter (MIC-SCA), and Corner Mount Bracket (MIC-CMB))



Warning!

To minimize the potential for corrosion on the housing, use only Bosch hardware and mounts.

5.2

Select the Mounting Location

1. Select the mounting location.

Select a secure installation location and mounting position for the device. Ideally, this is a location where the device cannot be interfered with either intentionally or accidentally. Ensure that the location has the appropriate clearance from power and lightning conductors, in accordance with *NEC725* and *NEC800* (*CEC Rule 16-224* and *CEC Section 60*).

Do not install the device near:

- Any heat sources
- Any overhead power lines, power circuits, or electrical lights, or where the device may contact power lines, circuits, or lights
- ▶ Ensure that the selected mounting surface is capable of supporting the combined weight of the camera and mounting hardware (sold separately) under all expected conditions of load, vibration, and temperature.



Notice!

MIC cameras must be secured to one of the following surfaces:

- Concrete (Solid/Cast)
- Concrete Masonry Unit (Concrete Block)
- Brick (all types)
- Metal (Steel/Aluminum, minimum 1/8-in. thick)



Caution!

Risk of lightning strikes

If the camera is installed in a highly exposed location where lightning strikes may occur, then Bosch recommends installing a separate lightning conductor within 0.5 m (1.6 ft) of the camera and at least 1.5 m (4.9 ft) higher than the camera. A good earth bonding connection to the camera housing itself will provide protection against damage from secondary strikes. The camera housing itself is constructed to cope with secondary strikes. If the correct lightning protection is applied, then no damage to the internal electronics or camera should result.

5.3

Select the Mounting Orientation

2. After selecting the mounting location, select the appropriate mounting orientation.

MIC Series cameras are designed to be mounted upright (straight up, 90°) or inverted (straight down, 90°). See the figures below for illustrations of the correct and the incorrect mounting orientations of MIC cameras.

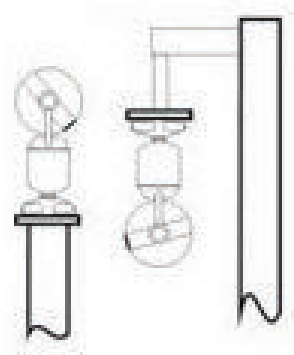

Correct mounting orientation of MIC camera - upright, inverted

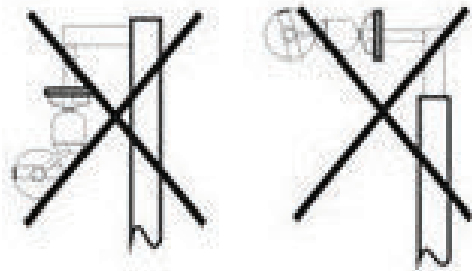

Incorrect mounting orientation of MIC camera

5.4

Install the Mounting Brackets

3. Install the mounting brackets.

Observe all appropriate safety precautions and local building regulations. Refer to the MIC Series Mounting Brackets Installation Guide for installation instructions.

6 Mount the Camera

To mount a MIC Series camera, follow these steps:



Warning!

Ensure not to damage the paint on the housing of the camera or the mount.

1. Carefully lift the camera to the mounting location.
2. Connect the female cable connector end (12-pin) of the shielded composite cable to the male plug in the base of the camera. Screw the cable connector sleeve onto the plug until it is secured firmly (approximately four (4) turns from the start of thread engagement).

7 Earthing the Camera

Earth the MIC Camera to metal on or attached to the mount.



Warning!

The camera must be earthed / grounded to meet EMC immunity standards.

Earth the camera using one of the supplied securing bolts. Only earth the camera at a single point to prevent earth loops and video distortion (hum bars), caused by electrical interference, from appearing on the camera picture in the control room. Please note:

- The camera module and housing are electrically isolated, so the housing should be safety earthed regardless. The safety earth should be a bonding connection (for example, one of the securing bolts) to the camera housing, or should be attached to the Earth terminal post on the PCD base of the camera.
- If the system is copper throughout and the camera pictures are fed back to the control room via coaxial copper cable, then the camera should be earthed only at the video termination point in the control room. In this case, the "Earth Link" on the PCB should be broken. Refer to *Earth Link on PCB, page 35*.
- If the video is transmitted back to the control room via some non-electrical connecting medium (for example, fiber optic, radio, or microwave link), then the camera should be earthed at the transmitter point in the power supply unit. The PSU "Earth Link" may be used for this purpose.
- If dual earthing is unavoidable, then a video isolation transformer should be fitted between the two earths.

8 Finalize Camera Mounting

Finalize Camera Mounting



Warning!

It is essential that the connections and the base of the camera are completely sealed from water ingress. Any water getting into the connector is liable to cause corrosion to the connector pins, leading to unreliable operation of the camera unit. This is especially imperative for a camera mounted in inverted orientation.

1. To prevent water ingress, seal the threads of the securing bolts using PTFE tape (not supplied). An additional gasket or suitable silicone sealant can be applied liberally to the threads prior to final tightening to ensure a watertight seal between the base of the camera and the mounting surface.
2. Use M8 x 20 mm stainless steel nuts, bolts, and washers to secure the base of the camera to the mounting surface.
3. Tighten all bolts securely.
4. Secure all cabling and conduit.



Caution!

The upright unit can be mounted either with the camera ball up or down. So that the picture from a camera installed with the camera ball down appears properly, rotate the camera tilt axis 180°. For more information, see *Configuring the Camera for Inverted Operation*, page 51.

9 Install the MIC (standard) PSU

9.1 MIC PSU Overview

**Caution!**

Use only the power supply specified for your specific model of camera.

Bosch provides a range of power supply units (PSUs) for MIC Series cameras. These units have a variety of common voltages and provide all the connections needed for power, telemetry and video.

**Warning!**

These power supply units are NOT explosion-proof and must be installed outside of the hazardous environment.

Each MIC PSU provides all of the connections needed for power, video, and telemetry for a single MIC camera. Each MIC PSU has CE and FCC approval and has a cast-aluminum enclosure that is weather-resistant (rated IP65). Features include:

- A provision for driving various optional interface cards mounted internally to the MIC power supply enclosure (for example, an 8-input alarm card (MIC-ALM))
- A provision for a signal interface card (MIC-BP4) to connect telemetry to Bosch Biphas equipment
- Screw termination of all cables (composite, telemetry, and ancillary) into and out of the enclosure
- Earth isolation and termination within the unit to control video earthing correctly and thus prevent earth loops

Each MIC PSU ships with the following parts:

- Three (3) M12 cable glands for telemetry, video and ancillary equipment
- One (1) M16 gland for connection of the shielded composite cable to the MIC camera
- One (1) 1/2 in. NPT cable gland for the power cable connection
- One (1) 1/2 in. NPT and one (1) M12 blanking plug

The transformer fitted to these designs is thermally protected and automatically cuts out if the transformer core temperature exceeds 40 degrees C. On cooling, the transformer will become operational again. In addition, the unit provides all the terminations required to connect a MIC440 camera to third party equipment. A second, independent 12v (600mA) power supply is also included to drive any internally fitted optional interface cards.

9.2 About the MIC Shielded Composite Cable

All connections (power, telemetry, video) to the MIC camera are provided through the screw terminal connections in the MIC power supply. MIC shielded composite cables are multi-conductor cables of various lengths (and gauges ranging from 14 - 18) that provide all power, video, and telemetry connections between the MIC PSU and the MIC camera. The cables are pre-made with a female terminated connector (12-pin) at one end for attachment to the male connector installed into the base of the camera. The other end of the cables has free (non-terminated) wires for wiring into terminals in the MIC PSU. The composite cable consists of two pairs (24AWG) plus 4 cores of (22 AWG), 2 cores of (24 AWG), and one coax core for the video signal to a maximum distance of 25 m.



Notice!

Bosch Security Systems does not recommend using the shielded composite cable for distances greater than 25 m between the MIC camera and the MIC power supply.

For installations that require the camera to be more than 25 m from the power supply, Bosch recommends that a 2 m cable be connected to a junction box (Exd rated for MIC440) from which telemetry, video, and power can be broken out into separate cables and appropriate wiring used to extend the distance to suit.



Warning!

Bosch recommends connecting the cable to the unit before taking the unit for mounting on-site.



MIC shielded composite cable before connection to a MIC440 camera



MIC shielded composite cable connected to a MIC440 camera

9.3

Composite Cable Color-coding

The standard color coding used in MIC composite cables is as follows:

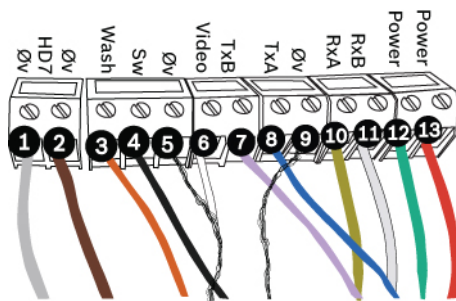

Figure 9.1: Exploded View of Composite Cable Connections

Camera Cable Connector Pin	Signal Name	Description	Cable Wire Color
1	Washer Drive Rtn	Auxiliary Connection	Grey
2	Tamper Sw Rtn	Auxiliary Connection	Brown

Camera Cable Connector Pin	Signal Name	Description	Cable Wire Color
3	Washer Drive	Wash Signal	Orange
4	Tamper Sw	Alarm Communications	Black
5	Video Return	Video Signal Ground	Coax Screen
6	Video Output	Video Output to Control Room	Coax Core
7	Full Duplex Tx B+	Telemetry I/O to RS-422/485	Violet
8	Full Duplex Tx A-	Telemetry I/O to RS-422/485	Blue
9	0v	Ground	Shield
10	Full Duplex Rx A- Half Duplex Tx/Rx A	Telemetry I/O to RS-422/485	Yellow
11	Full Duplex Rx B+ Half Duplex Tx/Rx B	Telemetry I/O to RS-422/485	White
12	Power Input 2	Low Voltage Power Input	Green
13	Power Input 1	Low Voltage Power Input	Red

Video output signal conforms to CCIR PAL or NTSC 1V Composite format. Telemetry signals all conform to the RS-485 / RS-422 standard. The unit continuously monitors incoming telemetry whether in full or half duplex mode.

In full duplex mode, the Tx pins are tri-state except during transmission times. This may cause problems when interfacing to some fiber optic converter units. Check out the Commissioning notes for ways of overcoming these problems. In 2 wire Half Duplex mode (RS-485), the Rx pins are used to transmit data to the MIC440.

The washer connections can be used to operate a relay in the power supply unit, which in turn can activate a pump.

9.4 Earth Link on PCB

The printed circuit board (PCB) of each MIC PSU (IR and non-IR) has one Earth Link option, near terminal block HD1, to allow the PSU to be set up for different earthing schemes:

- If there is a separate connection between video screen and earth, the Earth Link should be broken. This usually occurs on copper-connected systems where all of the copper video coaxes are taken back to the control room to be connected to a central earth point.
- If fiber optics or other indirect connections are used to get data and video to and from the control room, then the Earth Link should be left intact, as long as it is the only camera-end earth reference point.

9.5 Fuse Ratings

The MIC PSUs for cameras have four (4) off 20 mm fuses (numbers 13 - 16 in the figure “Layout of MIC-240PSU-2 and MIC-115PSU-2”) in fuse holders. The ratings for these fuses are fixed on the low voltage secondary side but change with input voltage on the high voltage

primary side. The following table shows the fuse values that should be fitted to provide proper protection for the MIC-240PSU-2 and MIC-115PSU-2 power supplies. **Note:** FS 4 does not exist.

Fuse ID	Fuse Function	Type	Rating for 240 V Primary	Rating for 115 V Primary	Rating for 24 V Primary
FS 1	MIC camera protection	Glass	1.6 A anti-surge (T)	1.6 A anti-surge (T)	1.6 A anti-surge (T)
FS 2	Primary protection	Glass	200 mA quick blow	500 mA quick blow	2.5 A quick blow
FS 3	Heater protection 1	Glass	1.6 A anti-surge (T)	1.6 A anti-surge (T)	1.6 A anti-surge (T)
FS 5	Heater protection 2	Glass	1.6 A anti-surge (T)	1.6 A anti-surge (T)	1.6 A anti-surge (T)

9.6 Alarm Inputs

The table below identifies the number of alarm inputs and outputs available in MIC power supply units, depending on whether or not an 8-input alarm card is installed.

MIC PSU	8-input Alarm Card (MIC-ALM)?	Number of Alarm Inputs	Number of Alarm Outputs
MIC-24PSU-2, MIC-115PSU-2, MIC-240PSU-2	No	1	0
	Yes	8	2

Table 9.1: Number of alarm inputs and outputs in MIC PSUs

9.7 Layout of MIC Power Supply Units (PSUs)

Layout of MIC-240PSU-2 and MIC-115PSU-2

The figure below displays the layout of the PCB in the MIC PSUs for non-IR cameras, with call-out numbers to the side of or below the connection/terminal ID or the terminal, and 'on' the fuses. The table below the figure identifies the connections.

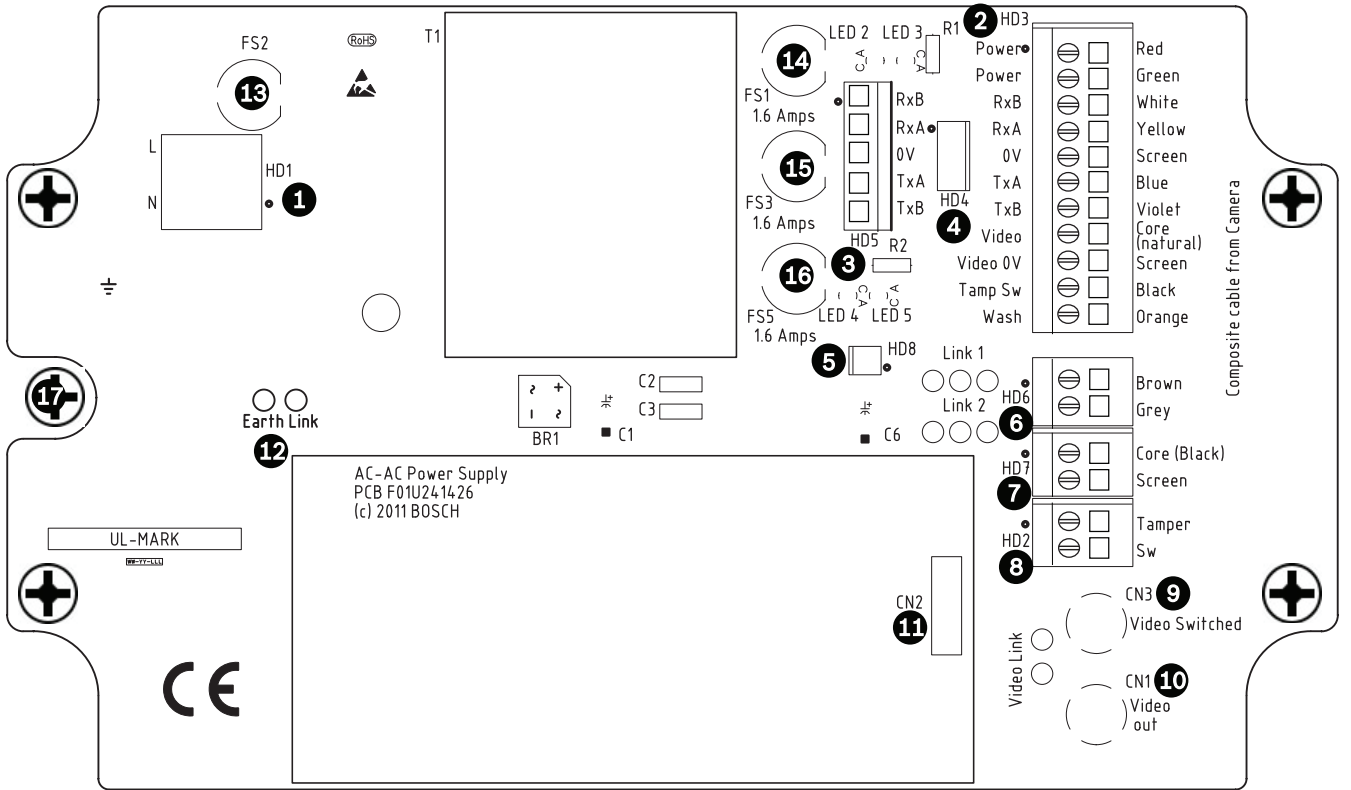

Figure 9.2: Layout of MIC-240PSU-2 and MIC-115PSU-2

No.	PCB Marking	Description/Function of Connection / Terminal	Type of Connection/ Terminal
1	HD1	AC Power input connector Live (HD1-1); Neutral (HD1-2) [Ground wire connects to earth termination post]	Screw terminal
2	HD3	Shielded composite cable header (connections to camera)	Screw terminal
3	HD5	RS-485 control header	Screw terminal
4	HD4	Telemetry header	Molex connector
5	HD8	USB to RS-485 converter [Not used for MIC440.]	Molex connector
6	HD6	[Optional] Auxiliary, heater [Not used for MIC440.]	Screw terminal
7	HD7	Video (composite cable)	Screw terminal
8	HD2	Tamper switch header	Screw terminal
9	CN3 Video Switched	Coax connection (Switched visible/thermal video out) [Not used for MIC440.]	BNC socket
10	CN1 Video Out	Coax connection header (Visible video out)	BNC socket
11	CN2	Auxiliary / add-on card terminal	Plug in
12	Earth Link	Earth Link	

No.	PCB Marking	Description/Function of Connection / Terminal	Type of Connection/ Terminal
13	FS2	Fuse 2 - Primary protection	--
14	FS1	Fuse 1 - MIC camera protection	--
15	FS3	Fuse 3 - Heater protection 1	--
16	FS5	Fuse 5 - Heater protection 2	--
17	--	Earth termination post	Ring terminal

9.8 Installation Warnings and Prerequisites

Danger!

ELECTRICAL SHOCK HAZARD

To reduce the risk of electrical shock, disconnect power before opening or working on any power supply unit. Power must be disconnected before replacing any fuse in the MIC PSU. Power supply units have power supplied whenever the power cord is inserted into the power source.



MIC PSUs have a separate internal shield covering the power cable input terminal block (HD1). Only suitably qualified persons should remove this shield and connect the mains power cable. The shield **MUST** be re-installed and fully secured before connecting the power.

The power supply cable shall have conductors of a maximum size of 12 AWG.

Branch circuit protection incorporating a 15 A, 2-pole, listed circuit breaker or branch rated fuses are required. A readily accessible 2-pole disconnect device with a contact separation of at least 3mm must be incorporated externally to the equipment.

Warning!

To meet UL standards and ratings, all external wires (power and I/O cabling) for installation applications to the device **must be** routed separately through different permanently earthed metal conduits (not supplied).



Notice!

Use only UL-listed liquid tight strain reliefs for conduits to the power supply box to ensure that water cannot enter the box. You must use watertight conduits and fittings to meet NEMA 6P or to maintain IP68 standards.



Notice!

MIC PSU enclosures are not EXD rated and must be replaced with a **certified** enclosure if installed within a hazardous area.



Caution!

Except for the Earth Link, heater links, and applicable fuses, the MIC PSUs have no user-adjustable parts. MIC cameras have no user-serviceable parts.





Notice!

Do not connect MIC IR units to a MIC PSU with the heater option enabled as this can damage the cameras. Ensure that an IR power supply is used with a MIC IR camera unit. Heaters are available for MIC612 cameras only.



Caution!

Bosch recommends using an uninterruptible power supply (UPS) in connection with a MIC camera/PSU installation.



Notice!

To maintain the IP rating of the power supply enclosure, install only listed or recognized conduit hubs or fittings with the same environmental rating as the enclosure in compliance with the installation instruction of the hub or fitting.



Notice!

Refer to the *MIC Series Power Supply Installation Manual* included with the PSU for full details on installing a MIC Series PSU and connecting to a MIC Camera.

9.9

Installation Instructions (Power Supply)

To install the power supply unit (PSU), follow these steps:

1. Select a secure installation location for the PSU. Ideally, this is a location where the device cannot be interfered with either intentionally or accidentally.

Bosch recommends using an environmentally suitable, lockable equipment cabinet.

2. Loosen the four (4) captive Phillips head screws on the top of the lid of the power supply enclosure. Lift the lid and set it upside down next to the enclosure.



Notice!

Do not stretch or cut, or otherwise disturb, the earth core cable (shown in the figure below) to the inside of the lid and to the earth termination post.

3. Locate the four (4) mounting holes of the power supply enclosure.

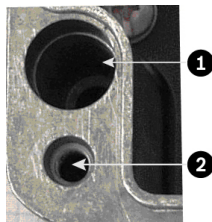

Figure 9.3: Holes for screws for mounting enclosure mounting; holes for screws for enclosure lid

Number	Description
1	Hole for mounting screw in enclosure
2	Hole for lid screw in enclosure

4. Drill four (4) holes in the mounting surface for the mounting anchors appropriate for M6 screws (not supplied).

5. Secure the enclosure to the mounting surface using four (4) M6 stainless steel screws and washers (not supplied), which fit through the large holes in the enclosure.



Notice!

If you are securing the power supply enclosure in a vertical position (for example, on a wall), one person should hold the enclosure lid while another secures the enclosure body in place, to avoid damage to any part of the enclosure, and/or injury to the installer(s).

6. Unscrew the two (2) M3 screws on the internal high voltage input head-end shield (marked with "Danger") covering the mains cable terminal HD1; retain the screws.

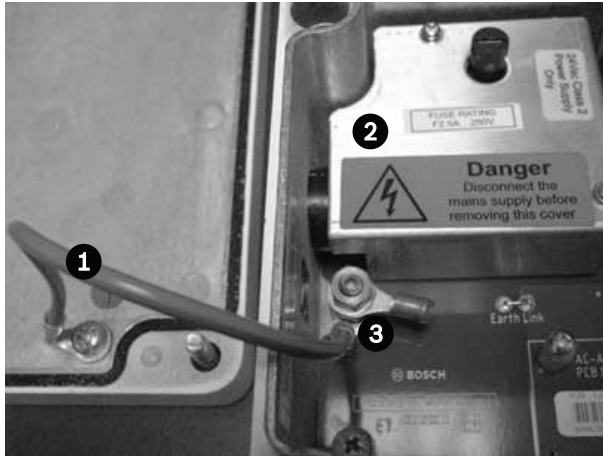

Figure 9.4: Enclosure showing shield and earth core cable between earth terminal post and enclosure lid

Number	Description
1	Earth core cable to enclosure lid
2	Internal shield
3	Earth termination post

7. Remove the internal shield and set it nearby, outside of the PSU enclosure. You can now access the hole for the power cable and the M20 blanking plug covering the hole.

8. Remove the blanking plug covering the hole for the power cable. Install suitable (metal) conduit (not supplied) in the hole. Secure the conduit as recommended by the conduit manufacturer.



Caution!

Only installations with conduit meet UL standards. If you choose to use a power cord without conduit (not recommended), fit the 1/2 in. NPT cable gland (supplied) in place of the blanking plug. Note: It is easier to fit the power cord through the cable gland outside of the enclosure, and then attach the gland to the enclosure. Ensure that the cable glands have sufficient room to allow for the cables to enter (approximately 60 mm on either side of the enclosure).

9. Prepare the power cable as needed, and then feed the cable into the enclosure.

10. Connect the Live and Neutral cores to the correct screw terminals on terminal block HD1 as identified in the table below and printed on the PCB. Observe polarity and voltage.

PCB Marking	Description
L	Live
N	Neutral
	Earth / Ground

11. Remove the brass nut and copper washer from the earth termination post (item 3 in the figure “Mains input with shield removed...”); set these aside.
12. Remove the ring terminal (supplied).
13. Insert the earth core from the mains cord (item 2 in the figure “Mains input with shield removed...”) into the crimp portion (size M6, UL-certified) of the ring terminal and crimp it in place.
14. Place the ring terminal onto the earth termination post.
15. Replace the copper washer. Secure with the brass nut.

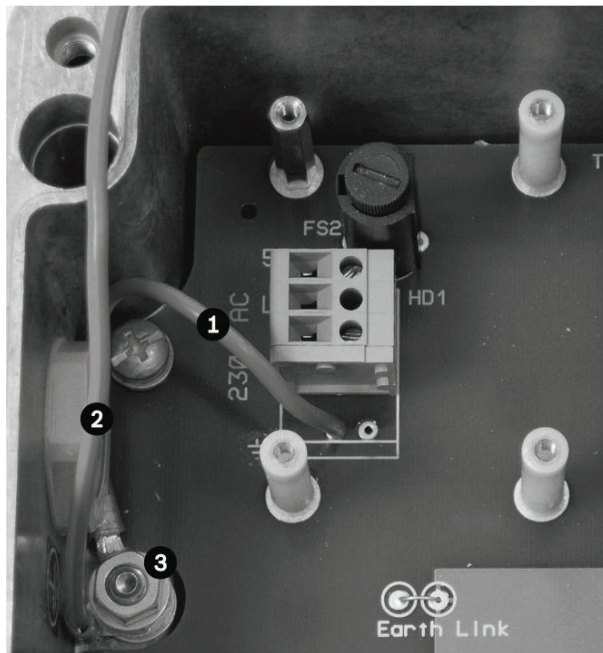

Figure 9.5: Mains input with shield removed, showing terminal block HD1 before wiring

Number	Description
1	Earth core cable to enclosure lid
2	Earth core cable to power supply PCB
3	Earth termination post

16. Replace the internal shield, taking care to avoid pinching the cables. Tighten the screws.
17. Feed the unconnected end of the shielded composite cable through the top-right M16 cable gland (item 2 in the figure “MIC PSU Enclosure, with cable glands identified”).

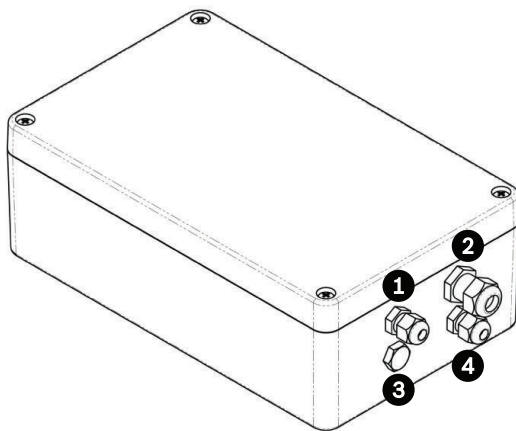

Figure 9.6: MIC PSU Enclosure, with cable glands identified

Number	Description	Cable Gland Size
1	Optical Video out	M12
2	Composite cable	M16
3	Optional switched video output	M12
4	Head-end / Telemetry controls	M12

18. Connect the shielded composite cable to terminal block HD3 (and, if necessary, HD6 and HD7) following the color coding as shown in the figure below, and printed on the PCB.

No .	ID, Connection/ Terminal + Pin	PCB Mark, Signal	Description/Function of Connection	PCB Mark, Cable Color
1	HD3-1	Power	Low Voltage Power (Input 1) / AC supply	Red
2	HD3-2	Power	Low Voltage Power (Input 2) / AC supply return	Green
3	HD3-3	RxB	Telemetry I/O to RS-422/485 [Rx +] Full Duplex RxB/Half Duplex Tx/RxB	White
4	HD3-4	RxA	Telemetry I/O to RS-422/485 [Rx -] Full Duplex RxA/Half Duplex Tx/RxA	Yellow
5	HD3-5	0v	Ground [Drain Wire / Shield]	Screen (Black)
6	HD3-6	TxA	Telemetry I/O to RS-422/485 [Tx -] Full Duplex TxA	Blue
7	HD3-7	TxB	Telemetry I/O to RS-422/485 [Tx +] Full Duplex TxB	Violet
8	HD3-8	Video	Video output of optical camera to Control Room (Coax - BNC CN1)	Core
9	HD3-9	Video 0V	Video signal return (optical camera) (ground to Control Room) (Coax - BNC CN1)	Screen
10	HD3-10	Tamp Sw	[Optional] Tamper Switch	Black
11	HD3-11	Wash	[Optional] Washer Drive Signal	Orange

No .	ID, Connection/ Terminal + Pin	PCB Mark, Signal	Description/Function of Connection	PCB Mark, Cable Color
12	HD6-1	AUX1	[Optional] Auxiliary Connection (heater)	Brown
13	HD6-2	AUX2	[Optional] Auxiliary Connection (heater)	Grey
14	HD7-1	--	Video Switched Output to Control Room (Switched visible/thermal video out signal)	Core (Black)
15	HD7-2	--	Switched video signal ground	Screen (Black)

Note: If connecting a heater, see *Commissioning the Camera with Heater Option Fitted*, page 46.



Notice!

MIC440 cameras do not have an internal heater.

- 19. Slide back the cable so that the shield is in the middle of the gland.
- 20. Tighten the cable gland so that it grips firmly the shielded composite cable. It is important that the braided cable screen engages with the internal clamps of the cable gland to ensure correct EMC protection.
- 21. If necessary, connect a tamper switch to terminal block HD2.
- 22. Make the necessary video connections. Feed the coaxial cable of your choice--see the table below to identify the recommended cable types, maximum distance, and other specifications for the coax video connection between the MIC power supply and the head-end control system--through the top-left M12 cable gland (item 1 in the figure "MIC PSU Enclosure, with cable glands identified").

Cable Type; Maximum Distance	RG-59/U; 300 m (1000 ft) RG-6/U; 450 m (1500 ft) RG-11/U; 600 m (2000 ft)
Size	O.D. between 4.6 mm (0.181 in.) and 7.9 mm (0.312 in.)
Shield	Copper braid: 95%
Central Conductor	Standard copper center

- 23. Crimp the end of the cable with a BNC terminal connector.
- 24. Connect the Video Out cable to BNC socket CN1.
- 25. Feed telemetry cable through the bottom-right M12 cable gland (item 4 in the figure "MIC PSU Enclosure, with cable glands identified").
- 26. Connect head-end RS-485 control to terminal block HD5, as indicated in the table below:

PCB Marking (non-IR PCBs)	Telemetry Signal Name	Connection Description / Function	Pin Number
RxB	Rx +	RS485+ to camera	1
RxA	Rx -	RS485- to camera	2
0V	Ground	0V from control room	3

PCB Marking (non-IR PCBs)	Telemetry Signal Name	Connection Description / Function	Pin Number
TxA	Tx -	RS485- to control room	4
TxB	Tx +	RS485+ to control room	5

Note: The terminal block is positioned with the screw terminals on the left, next to the fuses. Pins are numbered from top to bottom in that orientation. Non-IR PSU PCBs are marked. 27. If connecting to additional add-on cards (for example, a card for 8-input alarms (MIC-ALM), and/or a Biphase card (MIC-BP4)), remove the second blanking plug that covers one of the holes for an M12 cable gland (item 3 in the figure “MIC PSU Enclosure, with cable glands identified”). Attach the supplied M12 gland. Make the appropriate connections to plug-in terminal CN2.



Notice!

For installation of the MIC 8-input Alarm Card (MIC-ALM) or Biphase converters (MIC-BP3 or MIC-BP4), please refer to their respective manuals.

- ▶ For physical alarm connections on MIC IR power supplies, connect alarm input cables to terminal block HD2, as indicated in the table below:

Signal	Pin Number
Alarm 1	1
0 V	2
Alarm 2	3
0 V	4
Alarm 3	5
0 V	6
Alarm 4	7
0 V	8

- ▶ On MIC IR power supplies, a washer drive is standard. A 24 VAC rated relay is fitted via the onboard fuse FS4 (rated at 2.5 Amps). Make the following washer pump connections to terminal block HD7 (marked Washer Drive on the PCB):

Signal	Pin Number
Washer Pump	1
Washer Pump	2



Warning!

The washer pump terminal is rated only to 24 VAC or VDC maximum voltage and is not suitable for Mains-operated pumps.

- ▶ Test the washer by pressing the red button marked SW1 PUMP ON on the PCB.
LED 3 illuminates in response to telemetry commands from the control room to turn on the washer. Note that the software in the camera prevents the washer from running more than 10 seconds continuously to prevent emptying the washer bottle.
28. After wiring is complete, connect the power supply to the power source.
29. Verify that the following LEDs are lit:

LED	Description
LED 2	18 VAC power on to camera
LED 4	Power on for optional heater
LED 3	18 VAC power on camera
LED 5	Power on for optional heater

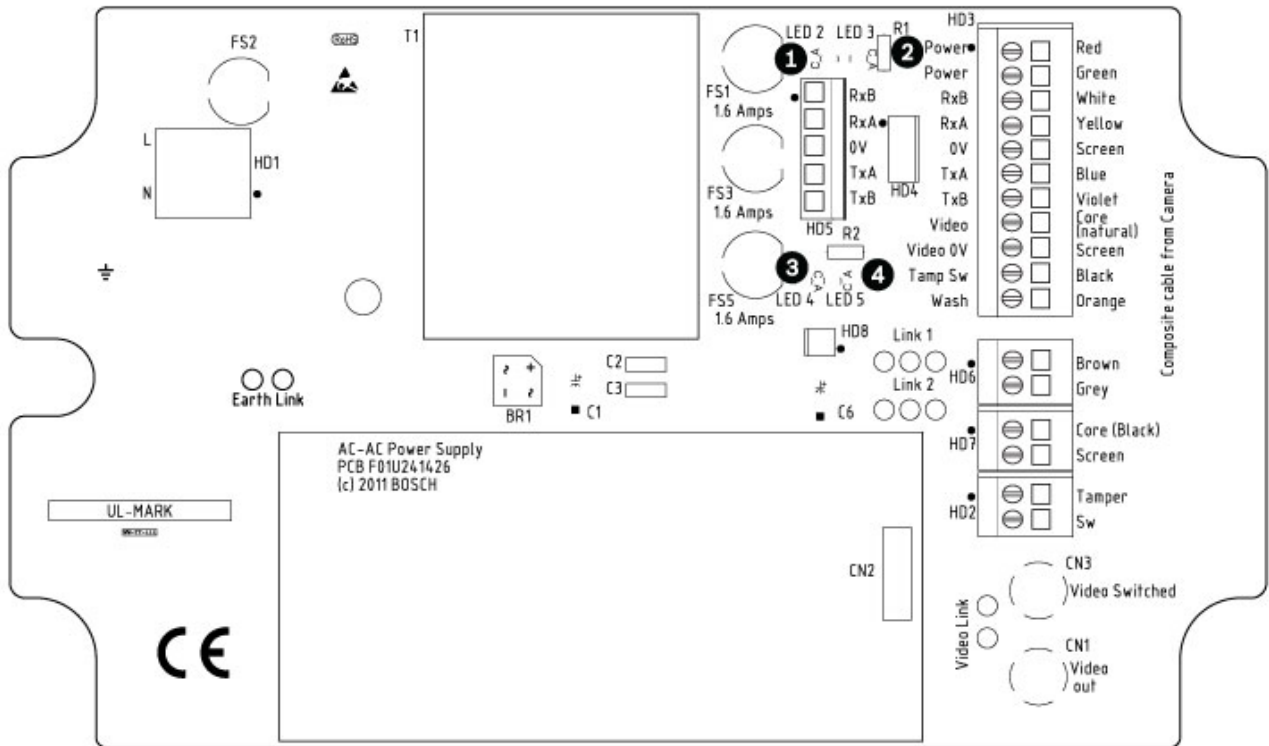

Figure 9.7: Position of LEDs - MIC Series power supply PCB

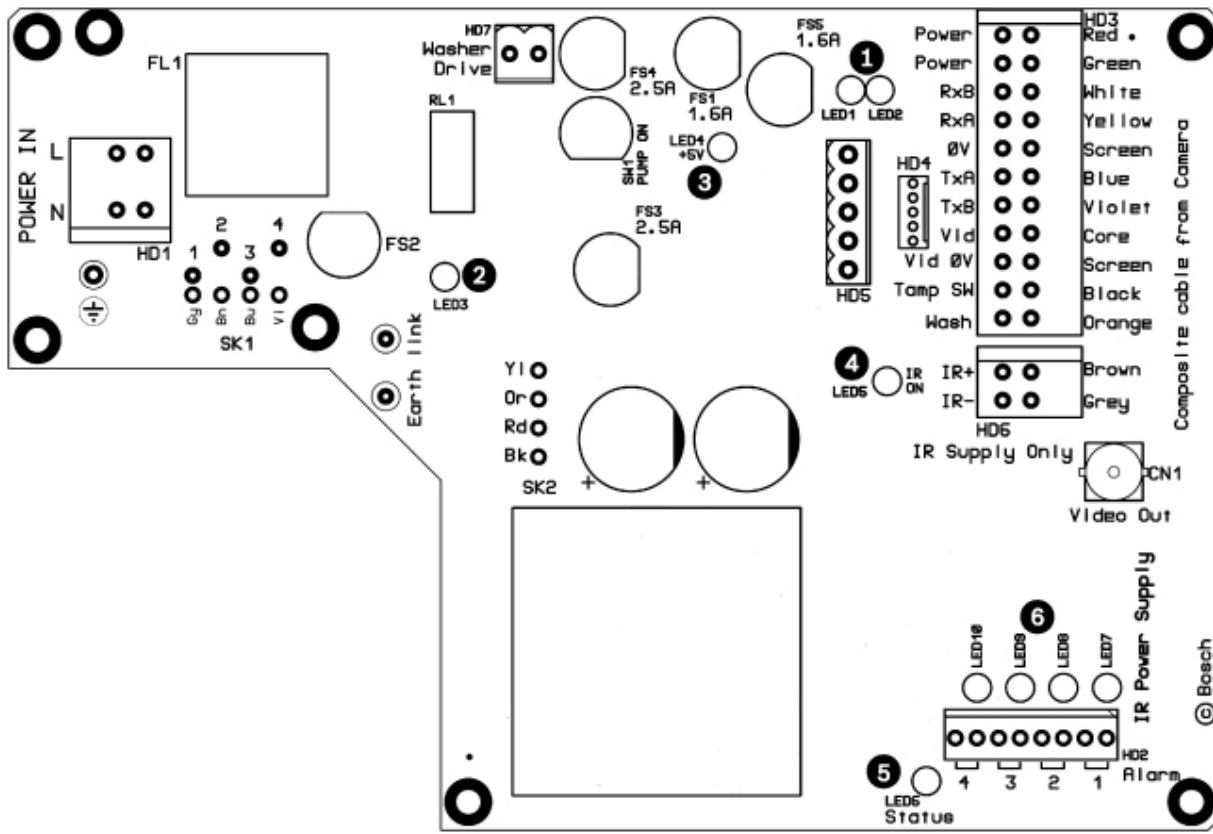

Figure 9.8: Position of LEDs - MIC Series IR power supply PCB

Number	LED	Description
1	LED 1 LED 2	Indicates that 18 VAC is available from the power supply and that the supply fuses are intact.
2	LED 3	Illuminates when the washer drive is on.
3	LED 4	Monitors the internally generate +5 V.
4	LED 5	Illuminates when the IR lamp supply is turned on by the camera telemetry.
5	LED 6	Status LED. Pulses On/Off when Multi Alarm is selected.
6	LED 7-10	Illuminate when the associated alarm is active.

30. Re-attach the enclosure lid and tighten the four (4) captive screws on the cover to ensure that the enclosure is watertight.

9.10 Commissioning the Camera with Heater Option Fitted

To enable the heaters, you must change two links on the printed circuit board (PCB) of the power supply. Follow these steps:

1. Disconnect the power supply from the power source.
2. Locate Link 1 and Link 2 on the PCB, next to terminal block HD6. The default setting is 0V.
3. Break the two solder links and remove any excess solder.

4. Solder the links, using tinned copper wire, from the left hand pads to the middle pads.
The power supply will now deliver 18 VAC to terminal block HD6.
5. Locate the Brown and Grey wires from the composite cable.
6. Connect the heater wires Brown and Grey to terminal block HD6 as labelled on the PCB.
The heaters are thermostatically controlled and will automatically turn on at +5 °C (+41 °F) and turn off at +15 °C (+59 °F).
7. Check all connections.
8. Close the PSU enclosure.
9. Reconnect the power supply to the power source.

10 Fit the Sunshield (MIC440)

The MIC440 Sunshield is designed to provide additional protection against direct solar radiation by reflecting solar exposure and creating an insulating gap between the environment and the surface of the camera. It is a two (2) part moulding and comes supplied with four (4) stainless steel set screws.



Caution!

DO NOT REMOVE the lid from the camera, and do not back drive the pan or tilt axis manually. Doing so will void the warranty. Back driving may also strip teeth off the internal gears.

To fit the sunshield, follow these steps:

1. Turn on the power to the camera so that you can rotate the camera head up to fit the bottom half of the sunshield (steps 2 through 4).
2. Rotate the camera under power--do not rotate by hand--until the bottom of the camera head is facing up.
3. Align the 4 posts/alignment tabs and the two screw holes of one piece of the sunshield with the corresponding posts and holes on the camera head. Push the sunshield until it fits snugly onto the camera head.
4. Place two of the socket head screws into the screw holes. Fasten the screws with a Torx wrench.
5. Rotate the camera under power--do not rotate by hand--until the top of the camera head is facing up.
6. Repeat steps three and four for the second half of the sunshield. When fitted properly, both halves of the sunshield should align and meet at the back of the camera head.

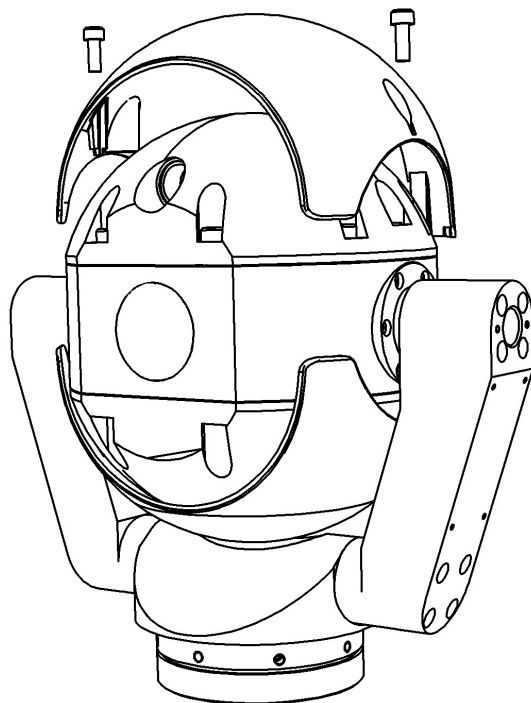

Figure 10.1: Sunshield and Screws being placed

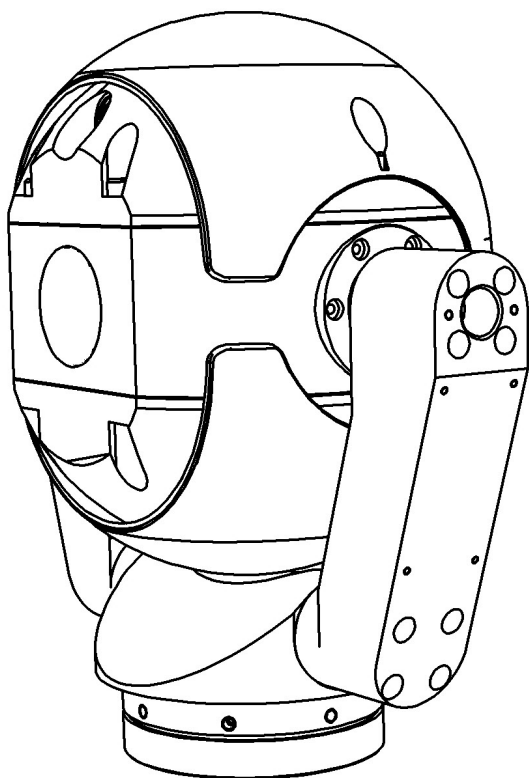

Figure 10.2: Side View of Fitted Sunshield

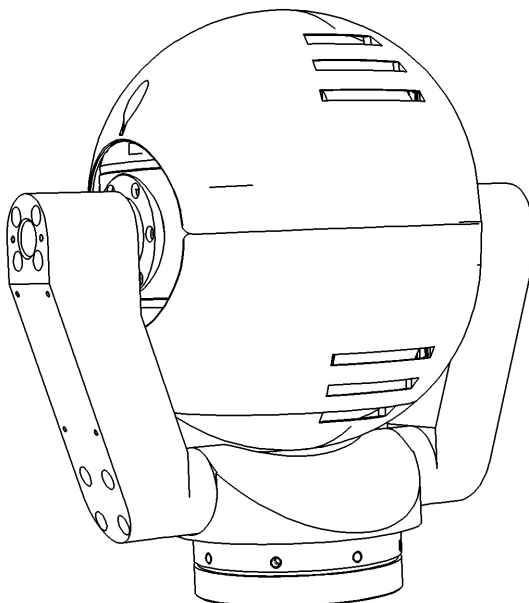

Figure 10.3: Back View of Fitted Sunshield

11 Connection

Connect and configure MIC cameras

To configure and operate/control the camera, you will need a computer, either an RS-232 to RS-485 adapter or the MIC USB to RS-485 signal converter (MICUSB485CVTR2), and software to facilitate easy setup and configuration of the camera:

Typically the RS-232/RS-485 adapter is connected to a serial port on a computer. The port will generally be assigned to Comm Port 1.

If your computer does not have a serial port, you can use the MIC USB to RS-485 signal converter (MICUSB485CVTR2) to connect the MIC camera to a USB port on the computer. Refer to the *MIC Series Power Supply Installation Manual* and to the *MIC Series USB485CVTR2 User Guide* for details.

12 Configuration

12.1 Addressing the Camera

Addressing the camera using Bosch protocol with Camset 4.12.00.06

The camera accepts a custom string of commands that change the camera address. The following procedure uses hexadecimal numbers to identify the camera address. Bosch recommends using a calculator with a decimal to hexadecimal converter to obtain the correct hexadecimal value for the address. (The Calculator included with Microsoft Windows operating systems contains a converter in the Programmer mode).

1. Launch Camset 4.12.00.06 and ensure that you can control camera.
2. Select Send Custom Command from the Advanced Setup menu.
3. Type the following string to send the AUX ON 14 command: 07,01,0E
4. Click the Send Now button.
5. Type the following string to send the AUX ON 21 command: 07,01,15
6. Click the Send Now button.
7. Type the following string to send the AUX OFF 21 command: 07,02,15
8. Click the Send Now button.
9. Type the following string to send the AUX OFF “new address” command and to set the camera address: 07,02,xx

where “xx” is the hexadecimal address for the camera. For example, use “AB” to set the camera address to 171.

- ▶ Click the Send Now button. The camera address is set.

12.2 Configuring the Camera for Inverted Operation

The video display from a camera installed in inverted position will appear upside down until you set the video orientation to “Inverted position.” Follow these steps:

1. Access the main Setup Menu of the on-screen display (OSD). The screen **Setup Menu** appears.
2. Select the submenu “PTZ Setup.” The screen **PTZ Setup** appears.
3. Select the option “Orientation.”
4. Select the value “Inverted,” which rotates the video 180°. The video should now appear upright.

13 Operation

For operation of the MIC440, refer to the tables below for the list of support protocols and commands.

Aux	Function	Description (MIC function)
1	Focus Control	On: Enables Manual Focus Off: Disables Manual Focus => Auto Focus
2	Digital Zoom Enable	On: Digital Zoom is enabled Off: Digital Zoom is disabled
3	Iris Control	On: Enables Manual Iris Off: Disables Manual Iris => Auto Iris
4	Auto Lowlight	On: Enables Auto Lowlight, Decrease frame rate for low light conditions Off: Disables Auto Lowlight, Returns to Auto Iris
5	Wiper	On: Wiper On Off: Wiper Off
6	Washer	On: Washer On Off: Washer Off
7	Proportional PTZ	On: Enabled, Pan and Tilt Speed is scaled according to Zoom position Off: Disabled, Normal PTZ
8	IR Lamps	On: Switches IR Cut Filter & Lamps On Off: Switches IR Cut Filter & Lamps Off
9	Camera Power	On: Video Output from Sony Camera module is enabled Off: Video Output from Sony Camera module is disabled
10	Backlight	On: Backlight On Off: Backlight Off
11	B&W	On: Black & White Mode Off: Color Mode
12	OSD	On: Shows Sony camera module On-Screen-Display Off: Hides Sony camera module On-Screen-Display
13	Shutter Speed (1/2 s)	On: Sets Shutter Speed to 1/2 s (fixed) Off: Returns to Auto Iris
14	Address Change Stage 1	On: Sets variable for Address Changing -> must call Aux 21 On, to continue Off: Clears variable for Address Changing SEE NOTE 1.
15	Pan Reverse	On: Pan direction is reversed Off: Pan direction is normal
16	Auto Alarm	On: Enables Auto Alarm Off: Disables Auto Alarm

17	Preset Tour	On: Starts Preset Tour (Either 5 or 10 Presets & dwell time as programmed) Off: Programs Preset Tour to include Presets 1 to 5 with a 5 sec dwell time Presets must be individually saved using either Camset LEARN or controller SET.
18	Preset Tour	On: Programs Preset Tour to include Presets 1 to 5 with a 15 sec dwell Off: Programs Preset Tour to include Presets 1 to 5 with a 60 sec dwell
19	Preset Tour	On: Programs Preset Tour to include Presets 1 to 10 with a 5 sec dwell Off: Programs Preset Tour to include Presets 1 to 10 with a 15 sec dwell
20	Preset Tour	On: Programs Preset Tour to include Presets 1 to 10 with a 60 sec dwell Off: Same as On.
21	Address Change Stage 2&3	On: Sets variable for Address Changing -> must call Aux 21 Off, to continue Off: Sets variable for Address Changing -> next Aux {A} Off, {A} is new address. SEE NOTE 1.
22	Auto Home (Inactivity)	On: Auto home enabled, will return to home position after idle for 300 seconds. Off: Auto home disabled
23	White Balance	On: Auto White balance Off: Outdoor White balance
24	Auto IR	On: Enables Auto IR, camera module switches to IR mode automatically (Auto Night Mode) Off: Disables Auto IR
25	Washwipe	On: Enables Washwipe, camera moves to Washwipe position on Washer On Aux Off: Disables Washwipe
26	Multialarms	On: Multialarms On, required for multi-alarm card and IR lamp control Off: Multialarms Off
27	Home to	On: Camera Auto Homes to Home Preset Returns to home position after idle for 300 seconds. (no PTZ for 300 seconds) Off: Camera Auto Homes to Preset Tour Activates Preset Tour 1 after idle for 300 seconds. (no PTZ for 300 seconds)
28	Shutter Speed (1/300s)	On: Sets Shutter Speed 1/300s (fixed) Off: Returns to Auto Iris
29	Shutter Speed (1/600s)	On: Sets Shutter Speed 1/600s (fixed) Off: Returns to Auto Iris
30	Shutter Speed (1/1000s)	On: Set Shutter Speed 1/1000s (fixed) Off: Returns to Auto Iris

Table 13.1: Bosch OSRD Aux Controls

Notes

1. Bosch OSRD camera Address change: The camera address may be changed using the following sequence of commands. This is similar to the “Fast Address” for AUTODOME VG4 model cameras, but utilizes a different set of AUX numbers and there are not any OSD messages displayed during this process.

- AUX ON 14 (Initiate Fast Address sequence)
- AUX ON 21 (Confirms that fast Address is desired)
- AUX OFF 21 (Camera is set to receive the new address)
- AUX OFF #; where # is the new address number for the camera

2. AutoPan is not enabled for the MIC440 with Bosch protocol.

3. Inverted Image is not enabled for the MIC440 with Bosch protocol.

Additional Pelco Functions for MIC440

Aux #/Functions	Go To Preset #
Set Auto Home Time to 10 secs	40
Set Auto Home Time to 30 secs	41
Set Auto Home Time to 1 min	42
Set Auto Home Time to 5 mins	43
Set Auto Home Time to 10 mins	44
Aux 1 On : Auto Focus On*	50
Aux 2 On : Digital Zoom On*	51
Aux 3 On : Auto Exposure On*	52
Aux 4 On : IR On* (B/W Night mode)	53
Aux 5 On : Wiper On*	54
Aux 6 On : Washer ONLY On*	55
Aux 7 On : OSD On*	56
Aux 8 On : Backlight On*	57
Aux 1 Off : Auto Focus Off*	58
Aux 2 Off : Digital Zoom Off*	59
Aux 3 Off : Auto Exposure Off*	60
Aux 4 Off : IR Off* (Color Day mode)	61
Aux 5 Off : Wiper Off*	62
Aux 6 Off : Washer Off*	63
Aux 7 Off : OSD Off*	64
Aux 8 Off : Backlight Off*	65

Note that Pelco auxiliaries can be re-mapped; therefore, the preset value may change as modified. The values in this table above represent the factory default configuration for Pelco protocol.

Presets & AUX Commands (MIC440)

Note: AD = American Dynamics; FV = Forward Vision; Pelco = Pelco D/P

Preset Function	AD	Bosch	FV	Pelco	VCL	Notes
Positions: Learn and Go To (Bosch Set/Shot)						
Preset Positions	1-27	1-34	1-64	1-15	1-49	
Multi Alarm Preset Positions (1 to 8)	28 35	35-42	50-57	16-23	50-57	
Wash Wipe Position	Learn 4	47	62	Learn 42	62	AD Go To 71 to activate Wash/Wipe
Auto Home Position	1	48	1	1		
Auto Alarm Position	5	49	63	43	63	

Aux/Presets	AD	Bosch	FV	Pelco	VCL	Notes
Reset Presets	Learn 51	Use Cams et	Use Cams et	Use Camset	127	
Auto Home ON (Inactivity)	Learn 64	AUX ON 22	Learn 204	Learn 34		Moves to home position after no PTZ for 5 minutes. Toggle (Bosch)
Auto Home to Tour [Sequence Preset]	Learn 65	AUX OFF 27	Learn 205	Learn 35	N/A	Toggle (Bosch)
Auto Home Off	Learn 66	AUX OFF 22	Learn 206	Learn 36	N/A	
Proportional Zoom On (Scaled PTZ)	Learn 44	Shot 62	Use Cams et	Learn 86		
Proportional Zoom Off (Scaled PTZ)	Learn 45	Shot 63	Use Cams et	Learn 87		
Start Auto Pan without Limits (Scan)	N/A	AUX 37 On	N/A	Go to 99	N/A	
Stop Auto Pan without Limits	N/A	AUX 37 Off	N/A	Go to 96	N/A	

Change Auto Pan Speed	N/A	N/A	N/A	Learn 95 Learn 1-40 STOP AutoPan before	N/A	
Save Auto Pan Left Limit	N/A	N/A	N/A	Learn 92	N/A	
Save Auto Pan Right Limit	N/A	N/A	N/A	Learn 93	N/A	
Start Auto Pan with Limits	N/A	N/A	N/A	Go To 98	N/A	
Stop Auto Pan with Limits	N/A	N/A	N/A	Go To 96	N/A	
Find End Stops	Learn 52	SET 115	Learn 98	Learn 45	66	
Softlimit Top Left [Set Top Left Soft Stop]	Learn 60	SET 95	Learn 200	Learn 88	120	Must Use Camset to clear
Softlimit Bottom Right [Set Bottom Right Soft Stop]	Learn 61	SET 96	Learn 201	Learn 89	121	Must Use Camset to clear
Pan Reverse On [Enable]	N/A	Shot 78	Learn 194	Learn 81	117	Toggle (VCL)
Pan Reverse Off [Disable]	N/A	Shot 79	Learn 195	Learn 80	117	Toggle (VCL)
Tilt Reverse On [Enable]	N/A	N/A	Learn 190	Learn 29	71	Toggle (Pelco D/P)
Tilt Reverse Off [Disable]	N/A	N/A	Learn 191	Learn 29	72	Toggle (Pelco D/P)
Reverse Image/[Image] Picture Flip (Mirror) On	Learn 40	N/A	Learn 188	Learn 30	69	Toggle (Pelco D/P)
Reverse Image/[Image] Picture Flip (Mirror) Off	Learn 41	N/A	Learn 189	Learn 30	70	Toggle (Pelco D/P)
Digital Zoom Enable (Lock)	N/A	N/A	Learn 210	Learn 84	103	Operator cannot control Digital Zoom
Digital Zoom Disable (Unlock)	N/A	N/A	Learn 209	Learn 85	104	Operator can turn Digital Zoom On/Off

Digital Zoom On/Off	N/A	Shot 52/53	Use Cams et	AUX 2 On/Off		
Autoflip_On	Learn 77	N/A	Learn 217	Learn 76	N/A	
Autoflip_Off	Learn 78	N/A	Learn 218	Learn 77	N/A	
Auto Lowlight On [Enable]	Learn 48	Shot 56	Learn 238	Learn 58	124	
Auto Lowlight Off [Disable]	Learn 49	Shot 57	Learn 239	Learn 59	125	
Wash Wipe On [Enable/Unlock]	Learn 79	AUX ON 25	Learn 219	Learn 78	101	
Wash Wipe Off [Disable/Lock]	Learn 80	AUX OFF 25	Learn 220	Learn 79	102	
Wiper On/Off	N/A	Shot 58/59	N/A	AUX 5 On/Off		AD – This is controlled by an output command. FV uses the WIPER key on the keyboards
Intermittent Wipe On	N/A	N/A	N/A	N/A	N/A	
Intermittent Wipe Off	N/A	N/A	N/A	N/A	N/A	
Auto Alarm On [Enable]	Learn 46	Shot 80	Learn 236	Learn 56	115	
Auto Alarm Off [Disable]	Learn 47	Shot 81	Learn 237	Learn 57	116	
Multi Alarm(s) On [Enable]	Learn 67	AUX ON 26	Learn 207	Learn 82	109	
Multi Alarm(s) Off [Disable]	Learn 68	AUX OFF 26	Learn 208	Learn 83	110	
Set Auto Home Tour 1-6	See Note 1	See Note 2	Learn 211– 216	Learn 50–55	N/A	1) AD 1 tour only; Define Pattern 1 (A0) & Save Pattern (A3) Run Pattern 1 (B0) 2) Bosch one tour only; see AUX 17-20 for options
Auto IR On [Enable Night Mode]	Learn 56	N/A	Learn 196	Learn 37	107	
Auto IR Off [Disable Night Mode]	Learn 57	N/A	Learn 197	Learn 38	108	

Set Baud 1200	N/A	N/A	N/A	N/A	106	
Set Baud 2400	N/A	N/A	N/A	Learn 28	N/A	
Set Baud 4800	N/A	N/A	N/A	Learn 41	N/A	
Set Baud 9600	N/A	N/A	N/A	Learn 40	105	
Show Startup [Boot]Message	N/A	N/A	Learn 99	N/A	N/A	
Address Change	Use Cams et; Valid Range 1-99	Bosch AUX 14 & 21 Valid Range 1- 126	Use Cams et Valid Range 1-254	See notes. Valid Range 1-254	126	Pelco: Learn 60 Twice; then Learn # for new address
Camera Command Preset1 to Preset10	N/A	N/A	Go To 240-249	Go To 240-249	240-249	
Camera Recalibrate	Learn 50	N/A	Learn 251	Learn 94	N/A	
Inverted (Adjusts the pan controls)	N/A	N/A	N/A	Learn 80	N/A	
Upright (Adjusts the pan controls)	N/A	N/A	N/A	Learn 81	N/A	

Pelco D Patterns

To Record/playback a Pattern: (Save Presets prior to this!)

1. Select the TOUR number to be recorded using Learn # (50 to 55 for Pattern 1 to 6); (Pelco requires entering the number, and then PRESS & HOLD the PRESET key for greater than 3 seconds. E.g. Pattern 6 would be 55, Press & Hold PRESET > 3 seconds.
2. START the Recording using Learn 48. (enter 48, Press & Hold PRESET).
3. Go to Preset #, wait the dwell time, go to next preset #, etc. (1 PRESET, 2 PRESET, etc.; this time just press & release the Preset key).

NOTE: As a result, the MIC will move to Preset 1, stay there until the next preset command is received (say 10 seconds), then move to the Next Preset.

4. STOP the Recording using Learn 49. (enter 49, Press & Hold PRESET).
5. Press the PATTERN key to playback that last activated/recorded tour.

Pelco D Change Address PRESET 60

To change the address of a camera, Learn preset 60 twice, then learn another preset. The number of the preset will become the new address. For example, to set a camera to address 32, Learn presets 60,60,32 without moving the camera or sending any other data in between.

Inverted/Upright

For units mounted like a dome, the left and right is reversed. Set this by learning preset 80

INVERTED Learn Preset 80

UPRIGHT Learn Preset 81

Autopan (Scan)

To change the scan speed, learn preset 95 followed by another preset. The second preset is the scan speed. The speed range is 1 to 40.

SCAN SPEED SET Learn Preset 95

To start a scan, GOTO preset 99.

To start a frame scan, (5 sec dwell at each end) GOTO preset 98.

To stop a scan, Goto preset 96 or move the joystick.

14 Maintenance and Troubleshooting

No User-serviceable Parts

Except for the external wiper blade, the device contains no user-serviceable parts. Contact your local Bosch service center for device maintenance and repair. In the event of failure, the device should be removed from site for repair.

On-Site Inspection

It is recommended that the device be inspected on-site every six months to check mounting bolts for tightness, security, and any signs of physical damage. Inspection of this device shall only be carried out by suitably-trained personnel in accordance with the applicable code of practice (for example, EN 60097-17).

Table of Troubleshooting Issues

The table below identifies issues that could occur with the camera, and how to resolve them.

Problem	Questions to Ask/Actions to Resolve the Problem
No camera control.	<ul style="list-style-type: none"> - Check the integrity of all RS-485 connections; ensure that they are secure. - Confirm that the address on the camera has been set to match the address of the head-end control system. - Confirm that the baud rates are correct. - Cycle the camera's power off and on.
Video is rolling, noisy, or distorted.	<ul style="list-style-type: none"> - Check the integrity of all connectors and splices of the composite cable. If O.K., then: <ul style="list-style-type: none"> - Contact Bosch Technical Support.
Nothing appears on the screen.	Are the power cord and line connection between the camera and monitor made properly?
The image on the screen is dim.	Is the lens dirty? If so, clean the lens with a soft, clean cloth.
The contrast on the screen is too weak.	Adjust the contrast feature of the monitor. Is the camera exposed to strong light? If so, change the camera position.
The image on the screen flickers.	Does the camera face directly into the sun or fluorescent lighting? If so, reposition camera.
The image on the screen is distorted.	Is the power frequency set properly in sync? If the power frequency is not set correctly, the line lock synchronization mode cannot be used. Set the synchronization mode to INT. (NTSC Model power frequency in LL mode: 60 Hz.)

<p>No video.</p>	<ul style="list-style-type: none"> – Check that the mains power to the power supply is on. – For IP-enabled cameras: Check to see if you have a web page. <p>If you do, then try cycling the camera’s power off and on.</p> <p>If you do not, then you may have the wrong IP address. Use Configuration Manager to identify the correct IP address.</p> <p>If O.K., then:</p> <ul style="list-style-type: none"> – Check that there is 24 V output from the transformer. <p>If O.K., then:</p> <ul style="list-style-type: none"> – Check the integrity of all wires and mating connectors to the camera.
<p>Picture is dark.</p>	<ul style="list-style-type: none"> – Check that the Gain Control is set to High. <p>If O.K., then:</p> <ul style="list-style-type: none"> – Check that the Auto Iris Level is set to the appropriate level. <p>If O.K., then:</p> <ul style="list-style-type: none"> – Check that the camera lens cover is removed. <p>If O.K., then:</p> <ul style="list-style-type: none"> – Check that the maximum Ethernet cable distance has not been exceeded. <p>If O.K., then:</p> <ul style="list-style-type: none"> – Restore all camera settings.
<p>Background is too bright to see subject.</p>	<p>Turn on backlight compensation.</p>

14.1 Cleaning MIC440

The MIC440 features an automatic cleaning cycle to ensure proper operation during daily use. The cleaning cycle occurs every 24 hours, based on a user-defined setting in Camset. During the cleaning cycle, the camera initiates a full-speed pan rotation in one direction, stops the rotation, then starts a full-speed pan rotation in the other direction. During the cleaning cycle, only some functions are available and the camera closes the Iris so that no picture is visible. The cleaning cycle interrupts any previous activity (for example, tours, autopan, sequence, scan), but will not interrupt an alarm condition. Once the cleaning cycle is complete, the camera returns to its previous activity, and the pan, tilt, iris, and focus settings are returned to the position they were in before the cleaning cycle began.

Cleaning Cycle Operation

The entire cleaning cycle takes approximately three (3) minutes and is divided into three phases:

- **Pre-cleaning Phase:** This phase starts 60 seconds before the first cleaning phase. During the Pre-cleaning Phase, an operator can delay the cleaning cycle for five (5) minutes or can cancel this instance of the cleaning cycle.

- **Cleaning Phase A:** This cleaning phase consists of one (1) minute of full-speed pan rotations (approximately 12 rotations) in one direction and a rotation stop. During Cleaning Phase A, an operator can delay cleaning by five (5) minutes or can cancel this instance of the cleaning cycle.
- **Cleaning Phase B:** This cleaning phase consists of one (1) minute of full-speed pan rotations (approximately 12 rotations) in the direction opposite to that used in Cleaning Phase A. During Cleaning Phase B, an operator can cancel this instance of the cleaning cycle.

Note: If a cleaning cycle time is not set in Camset, the first cleaning cycle starts 24 hours after the initial power up. Refer to the section below for setting the cleaning time in Camset.

Setting the Cleaning Cycle Time

An operator can set the time for the cleaning cycle using Camset version 4.11 or later. (To download the latest version of Camset, navigate to www.boschsecurity.com.)

The cleaning cycle start time is entered using a 12-hour clock; the default time is 1:00:00 AM.

1. Launch Camset.

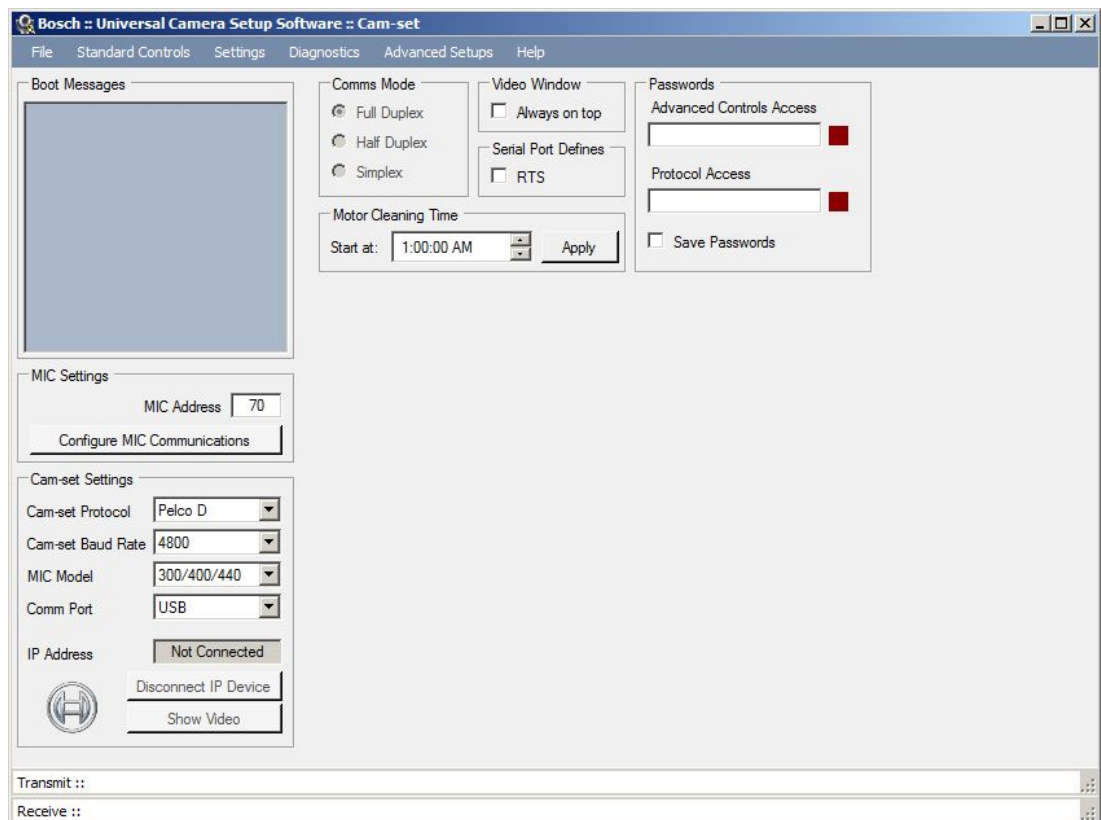

1. Choose the File menu and select Preferences. Camset opens the Preferences window.
2. Enter a start time for the cleaning cycle in the Motor Cleaning Time input box.
 - Place the cursor in the hour, minute, or seconds field. (Camset ignores the value in the seconds field).
 - Type a valid number for the hour (1-12), minute (0-59), and second (0-59) or use the up and down arrows to set the time.
 - Place the cursor in the AM/PM field and use the arrows to set this parameter.
3. Click Apply. The on-screen display shows the hours and minutes before the start of the cleaning cycle.

Running the Cleaning Cycle

During the three cleaning phases, an operator can use the Focus or Iris buttons located on the Camset Standard Control window or from a keyboard connected to the MIC440.

1. The on-screen display shows the following message 60 seconds before the start of the cleaning cycle:
CLEANING IN X SEC (where X is the number of seconds before the cleaning cycle starts)
2. During the 60-second Pre-cleaning Phase, the operator can:
 - Press the Focus Near or the Focus Far button to hide the Pre-cleaning Phase message. **Note:** This action does not delay the cleaning cycle.
 - Press the Iris Open or the Iris Close button to delay the Pre-cleaning Phase for five (5) minutes. The Pre-cleaning Phase stops and then restarts after five (5) minutes.
 - Once the Pre-cleaning Phase restarts, press the Iris Open or the Iris Close button again to cancel this cleaning cycle.
3. If the cleaning cycle is not cancelled, Cleaning Phase A begins and the camera starts the first full-speed pan rotation. The on-screen display shows the following message:
xx/120 (where xx is the elapsed time of the cleaning cycle in seconds)
4. During Cleaning Phase A, the operator can:
 - Press the Iris Open or the Iris Close button to delay cleaning for five (5) minutes. The cleaning phase stops and the Pre-cleaning Phase restarts after five (5) minutes.
 - Once the Pre-cleaning Phase or Cleaning Phase A restarts, press the the Iris Open or the Iris Close button again to cancel this cleaning cycle.
5. If the cleaning cycle is not cancelled, Cleaning Phase B begins and the camera starts the second full-speed pan rotation in the opposite direction. During Cleaning Phase B, the operator can:
 - Press the Iris Open or the Iris Close button to cancel this cleaning cycle.
6. Once the cleaning cycle is complete, the camera returns full control to the operator and the camera returns to its previous activity.

Delaying or Canceling the Cleaning Cycle

An operator can delay the cleaning cycle for five (5) minutes or can cancel the current instance of the cycle.

- To delay the cycle, press the Iris Open or the Iris Close button during the Pre-cleaning or Cleaning Phase A.
- To cancel the cleaning cycle, press the Iris Open or the Iris Close button again, after the delay, during the Pre-Cleaning, or during the Cleaning Phase A. Pressing Iris Open or Iris Close during Cleaning Phase B also cancels the cleaning cycle.

15 Decommissioning

15.1 Transfer

The unit should only be passed on together with this installation guide.

15.2 Disposal

	<p>Disposal</p> <p>Your Bosch product has been developed and manufactured using high-quality materials and components that can be reused.</p> <p>This symbol means that electronic and electrical devices that have reached the end of their working life must be disposed of separately from household waste.</p> <p>In the EU, separate collecting systems are already in place for used electrical and electronic products. Please dispose of these devices at your local communal waste collection point or at a recycling center.</p>
---	---

16

Technical data

For product specifications, see the datasheet for your camera, available on the appropriate product pages of the Online Product Catalog at www.boschsecurity.com.

17 Appendices

17.1 MIC440 Common Features by Protocol

MIC440 Common Features by Protocol

	American Dynamics	Bosch	Forward Vision	Pelco	VCL
PTZ Operations					
AutoPan without limits		X		X	
AutoPan with limits				X	
AutoPan Speed adjustable				X	
Number of Presets	35	42	64	23	57
Number of Preset Tours (Pattern Tours)	1	1	6	6	N/A
Proportional Zoom speed control (PTZ scaling)	X	X	X	X	X
Camera/Lens Operations					
Auto Lowlight (slow shutter)	X	X	X	X	X
Auto Night Mode	X	X	X	X	X
Digital Zoom control		X	X	X	X
Wiper/Washer Control					
Wiper ON/Off	X	X	X	X	X
Washer only		X	X	X	
Wash/Wipe Combined	X	X	X	X	X
Misc. Operations					
Auto pivot (auto flip)	X		X	X	
Auto Home (Inactivity; preset 1 or tour)	X	X	X	X	X
Fast Address Capability		X		X	X
Maximum Camera Address	99	126	254	254	128

Table des matières

1	Sécurité	69
1.1	À propos de ce manuel	69
1.2	Informations juridiques	69
1.3	Consignes de sécurité	69
1.4	Consignes de sécurité importantes	70
1.5	Avis importants	71
1.6	Informations de sécurité spécifiques pour la Protection contre les explosions	79
1.7	Assistance technique et service à la clientèle	81

1 Sécurité

1.1 À propos de ce manuel

Ce manuel a été compilé avec toute l'attention nécessaire ; toutes les informations qu'il contient ont fait l'objet de vérifications minutieuses. Le texte est complet et correct au moment de l'impression. En raison du développement continu dont les produits font l'objet, le contenu de ce manuel est susceptible d'être modifié sans notification préalable.

Bosch Security Systems ne saurait être tenu responsable d'un quelconque dommage résultant directement ou indirectement de défauts, de manques ou de divergences entre le manuel et le produit décrit.

1.2 Informations juridiques

Propriété intellectuelle

Le présent manuel est la propriété intellectuelle de Bosch Security Systems, Inc. et est protégé par des droits d'auteur. Tous droits réservés.

Marques commerciales

Tous les noms de produits matériels et logiciels utilisés dans ce document sont susceptibles d'être des marques déposées et doivent être traités comme tels.

1.3 Consignes de sécurité

Dans ce manuel, les notations et symboles suivants attirent l'attention du lecteur sur des situations particulières :



Danger!

Risque élevé : ce symbole indique un danger immédiat de type « risque d'électrocution » à l'intérieur du produit qui, s'il n'est pas évité, peut entraîner des blessures corporelles graves, voire mortelles.



Avertissement!

Medium risk (Risque moyen) : indique une situation potentiellement dangereuse qui, si elle n'est pas évitée, peut entraîner des blessures mineures ou modérées.



Attention!

Low risk (Risque faible) : indique une situation potentiellement dangereuse qui, si elle n'est pas évitée, peut entraîner des dommages matériels ou endommager le périphérique.



Remarque!

Ce symbole signale des informations ou une politique de la société concernant directement ou indirectement la sécurité du personnel ou la protection du matériel.

1.4 Consignes de sécurité importantes

Lisez, suivez et conservez l'ensemble des instructions de sécurité ci-après. Respectez les avertissements spécifiés sur l'appareil et dans les consignes d'utilisation avant toute utilisation.

**Attention!**

POUR ÉVITER TOUT RISQUE D'ÉLECTROCUTION, VEUILLEZ DÉBRANCHER L'ALIMENTATION LORS DE L'INSTALLATION DU DISPOSITIF.

**Attention!**

L'installation doit exclusivement être réalisée par un personnel qualifié, conformément aux normes ANSI/NFPA 70 (National Electrical Code® (NEC)), Code canadien de l'électricité, partie I (également appelé CE code ou CSA C22.1), ainsi que toutes les réglementations locales en vigueur. Bosch Security Systems, Inc. ne saurait être tenu responsable d'un quelconque dommage ou d'une quelconque perte résultant d'une installation incorrecte ou inadaptée.

**Avertissement!**

LES CÂBLES D'INTERCONNEXION EXTERNES DOIVENT ÊTRE INSTALLÉS CONFORMÉMENT AUX RÈGLEMENTS NEC OU ANSI/NFPA70 (POUR LE TERRITOIRE AMÉRICAIN) OU AU CODE CANADIEN DE L'ÉLECTRICITÉ, PREMIÈRE PARTIE, CSA C22.1 (POUR LE TERRITOIRE CANADIEN) ET DANS LE RESPECT DES RÉGLEMENTATIONS EN VIGUEUR DANS TOUS LES AUTRES PAYS. UN DISPOSITIF DE PROTECTION DES CIRCUITS DE DÉRIVATION COMPRENANT UN DISJONCTEUR BIPOLAIRE 20 A HOMOLOGUÉ OU DES FUSIBLES CALIBRÉS EST OBLIGATOIRE DANS L'INSTALLATION DU BÂTIMENT. UN DISPOSITIF DE SECTIONNEMENT BIPOLAIRE FACILE D'ACCÈS, AVEC SÉPARATION DES CONTACTS DE 3 mm MINIMUM DOIT ÊTRE INTÉGRÉ À L'INSTALLATION ÉLECTRIQUE DU BÂTIMENT.

**Avertissement!**

LES CÂBLES EXTERNES DOIVENT PASSER DANS UN CONDUIT MÉTALLIQUE MIS À LA TERRE DE FAÇON PERMANENTE.

**Avertissement!**

LA CAMÉRA DOIT ÊTRE INSTALLÉE DIRECTEMENT ET DE FAÇON PERMANENTE SUR UNE SURFACE NON COMBUSTIBLE.

**Avertissement!**

N'ouvrez pas la caméra dans des environnements présentant un danger.

En matière de sécurité, prenez toutes les précautions relevant du bon sens, notamment dans les situations où il existe un risque de blessure en cas de détachement et de chute d'une partie de l'assemblage.

- Vérifiez que le boîtier de l'unité est correctement mis à la terre. S'il est possible que le produit soit frappé par la foudre, assurez-vous que les connexions à la terre sont correctement effectuées sur le support de la base de l'unité.

- Évitez de diriger la caméra vers le soleil. Bosch Security Systems ne saurait être tenu responsable de tout dommage aux caméras ayant été dirigées directement vers le soleil.
- Avant le transport, il convient d'alimenter la caméra et de faire tourner la tête afin que la fenêtre soit orientée vers le bas. Cette manipulation contribue à protéger l'essuie-glace et la fenêtre pendant le transport.

Avertissement!

Ne modifiez pas manuellement les axes d'orientation de la caméra

Les combinaisons moteur/tête d'engrenage utilisées dans les caméras MIC ont été conçues pour permettre un mouvement d'orientation/inclinaison fluide de la caméra au cours d'un fonctionnement sur alimentation. Les têtes d'engrenage ne sont pas spécialement conçues pour une modification manuelle des « axes d'orientation » en aucune circonstance.

Même s'il est possible d'effectuer une telle opération sur des unités hors tension, rien ne garantit qu'une « modification des axes » sera possible sur chaque unité. Certaines unités peuvent même passer à l'état mécanique « verrouillé ».

Si cela se produit, appuyez simplement de mettre la caméra sous tension. Les fonctions de balayage horizontal et vertical de la caméra doivent maintenant fonctionner correctement.

**Avertissement!**

Déplacement des pièces !

Le déplacement des pièces risque d'occasionner des blessures. Il est donc conseillé de monter le dispositif de telle sorte qu'il ne soit accessible qu'au technicien et à l'installateur.

1.5

Avis importants

**Remarque!**

Cette caméra est destinée à être utilisée dans des environnements explosifs.



Accessoires - Ne placez pas l'appareil sur un pied, un trépied, un support ou une monture instable. Il risquerait de tomber, de provoquer des blessures graves et/ou d'endommager gravement l'appareil. Utilisez uniquement les supports de fixation recommandés par le fabricant. Si vous placez l'appareil sur un chariot, veillez à le déplacer avec précaution pour éviter qu'aucun élément ne bascule et ne vous blesse. Les arrêts brusques, les contraintes excessives et les surfaces inégales risquent d'entraîner le renversement du chariot et de l'appareil. Installez l'appareil conformément aux consignes d'installation.

Interrupteur omnipolaire - Intégrez un interrupteur unipolaire, avec séparation des contacts de 3 mm minimum à chaque pôle, à l'installation électrique du bâtiment. S'il s'avère nécessaire d'ouvrir le caisson, cet interrupteur omnipolaire servira de dispositif de sectionnement principal pour couper l'alimentation de l'appareil.

Signal de caméra - Protégez le câble à l'aide d'un protecteur principal si le signal est situé au-delà de 42 m, conformément à la norme *NEC800 (CEC Section 60)*.

Mise à la terre du câble coaxial :

- Si vous connectez un système de câblage externe à l'appareil, assurez-vous que ce système est mis à la terre.

- Connectez les équipements extérieurs aux entrées de l'unité uniquement une fois la fiche de terre de ce dernier connectée à une prise avec mise à la terre ou sa borne de terre correctement raccordée à une source de mise à la terre.
- Débranchez les connecteurs d'entrée des équipements extérieurs avant de débrancher la fiche ou la borne de terre.
- Suivez les consignes de sécurité appropriées, notamment celles relatives à la mise à la terre, avec tout périphérique extérieur connecté à l'unité.

La *section 810 du code national d'électricité américain (NEC), ANSI/NFPA n° 70* fournit des informations sur la mise à la terre de la monture et de la structure portante, la mise à la terre du câble coaxial vers un appareil de décharge, la taille des conducteurs de terre, l'emplacement du dispositif de décharge, la connexion aux électrodes de terre et les exigences relatives aux électrodes de terre.

	<p>Mise au rebut</p> <p>Votre produit Bosch a été conçu et fabriqué à partir de matériaux et composants haute qualité qui peuvent être réutilisés.</p> <p>Ce symbole signifie que les appareils électriques et électroniques en fin de vie doivent être mis au rebut séparément du reste des ordures ménagères. Dans l'Union européenne, des services de collecte séparés sont déjà en place pour les produits électriques et électroniques. Veuillez mettre au rebut ces dispositifs au centre de collecte ou de recyclage local.</p>
---	---

Calibres des fusibles - Pour la sécurité de l'appareil, la protection des circuits de dérivation doit être assurée par un fusible de 16 A maximum. Cette protection doit en outre être conforme à la norme *NEC800 (CEC Section 60)*.

Sources de chaleur - N'installez pas l'appareil à proximité de sources de chaleur telles qu'un radiateur, un système de chauffage ou tout autre dispositif générant de la chaleur (amplificateurs, etc.).

Déplacement - Coupez l'alimentation avant de débrancher l'appareil. Déplacez l'unité avec précaution. Les contraintes ou les chocs excessifs sont susceptibles d'endommager l'appareil.

Signaux extérieurs - L'installation de signaux extérieurs, en particulier en ce qui concerne le dégagement par rapport aux conducteurs des circuits prises et éclairage, et la protection contre les transitoires doit être conforme aux normes *NEC725* et *NEC800 (règles CEC 16-224 et CEC Section 60)*.

Équipement branché en permanence - Intégrez à l'installation électrique du bâtiment un périphérique de coupure d'alimentation facilement accessible.

Lignes électriques - Ne placez pas la caméra à proximité de lignes électriques aériennes, de circuits électriques, d'éclairages électriques ou à un endroit où elle risque d'entrer en contact avec de tels dispositifs.

Perte du signal vidéo - La perte du signal vidéo étant inhérente à l'enregistrement numérique, Bosch Security Systems ne saurait être tenu responsable d'un quelconque dommage résultant de données vidéo manquantes.

Afin de réduire les risques de perte d'informations, il est recommandé d'utiliser plusieurs systèmes d'enregistrement redondants et de mettre en œuvre une procédure de sauvegarde pour l'ensemble des informations analogiques et numériques.

Introduction d'objets et infiltration de liquides - À l'exception du connecteur à sa base, la caméra peut être exposée à des liquides non corrosifs sans subir de dommage. N'enfoncez jamais d'objets dans le connecteur du socle car cela pourrait endommager ses broches et affecter le bon fonctionnement de la caméra.

Alimentation - Utilisez exclusivement le type d'alimentation indiqué dans ce manuel/sur l'étiquette de l'unité. Assurez-vous que le courant nominal du câble d'alimentation est adapté à ce dispositif. Avant de poursuivre, débranchez l'alimentation du câble à installer sur le dispositif.

- Pour les dispositifs nécessitant une alimentation externe, utilisez exclusivement les sources d'alimentation homologuées ou recommandées.
- Pour les dispositifs à source d'alimentation limitée, cette source d'alimentation doit être conforme à la norme EN 60950. L'utilisation d'autres types de source d'alimentation risquerait d'endommager le dispositif, voire de provoquer un incendie ou une électrocution.
- Pour les dispositifs nécessitant une alimentation de 24 Vca, la tension d'alimentation du dispositif ne peut excéder $\pm 10\%$ (ou 28 Vca) Le câblage fourni par l'utilisateur doit être conforme aux codes électriques en vigueur (niveaux de puissance de classe 2). L'alimentation ne doit pas être mise à la terre au niveau des bornes de connexion et des bornes d'alimentation du dispositif.
- En cas de doute sur le type d'alimentation à utiliser, consultez votre revendeur local ou votre fournisseur d'électricité.

Orage - Pour une protection accrue en cas d'orage, ou si vous n'avez pas l'intention d'utiliser le dispositif pendant une période prolongée, débranchez le dispositif de la prise murale et déconnectez le système de câblage. Cette opération permet d'éviter les dégâts au niveau du dispositif en cas d'orage ou de surtension des lignes électriques.

Eau - Ne placez pas le bloc d'alimentation de la caméra près d'un point d'eau, par exemple près d'une baignoire, d'un évier ou d'une piscine. Les blocs d'alimentation répondent à la norme IP65 et sont compatibles avec un usage en extérieur. Cependant, pour des raisons de sécurité, Bosch recommande de les installer dans une armoire adaptée. La caméra offre une étanchéité de type IP68, elle peut parfaitement être utilisée dans un environnement humide ou en extérieur, tant que le connecteur de câble du socle est correctement scellé.

Ventilation - La caméra est un dispositif totalement étanche ne nécessitant aucune mesure concernant la ventilation.

Dégâts nécessitant des réparations – Coupez l'alimentation avant de débrancher l'appareil. Confiez à un réparateur qualifié toute opération de réparation, par exemple :

- détérioration du cordon ou de la fiche d'alimentation ;
- infiltration de liquide dans le dispositif ;
- introduction d'objets dans le dispositif ;
- le dispositif est tombé, ou bien son boîtier ou l'armoire dans laquelle il se trouve ont été endommagés ;
- dégradation notable des performances du dispositif ;
- le dispositif ne fonctionne pas normalement, malgré l'observation des consignes d'utilisation.

Réparation - N'essayez pas de réparer vous-même l'appareil. Toute opération de réparation doit être confiée à un réparateur qualifié.



Avertissement!

Ces blocs d'alimentation ne sont PAS à l'épreuve des explosions et doivent être installés à l'écart de zones dangereuses.



Attention!

Utilisez uniquement le bloc d'alimentation spécifié pour votre modèle de caméra.

**Attention!**

La caméra MIC440 est conçue pour une utilisation avec des gaz inflammables et vapeurs avec un appareil des groupes IIA, IIB et IIC et avec la classe de température T6. Le produit est homologué pour une utilisation à des températures comprises entre -20 et +60 °C et il ne doit pas être utilisé en dehors de ces plages.

**Avertissement!**

Bosch recommande de raccorder le câble à l'unité avant de saisir celle-ci pour un montage sur site.

**Attention!**

Toute boîte de jonction ou tout caisson utilisé pour le montage du bloc d'alimentation ou la séparation des câbles DOIT ÊTRE correctement calibré pour l'installation. Les caissons de blocs d'alimentation MIC ne sont pas homologués Exd et doivent être placés à l'intérieur d'un caisson certifié s'ils sont installés dans une zone dangereuse.

Pour une protection renforcée dans les installations en zone dangereuse, il est nécessaire d'utiliser en externe un passage de câbles métallique approprié pour que le câble composite puisse relier le bloc d'alimentation au presse-étoupe Exd (non fourni) dans l'adaptateur pour gaine large (MIC-DCA).

**Remarque!**

Bosch Security Systems ne recommande pas l'utilisation d'un câble composite blindé pour des distances supérieures à 25 m entre la caméra MIC et le bloc d'alimentation MIC.

**Avertissement!**

Afin de minimiser le risque de corrosion sur le caisson, utilisez uniquement le matériel et les supports Bosch.

**Remarque!**

Les caméras MIC doivent être fixées à l'une des surfaces suivantes :

- Élément en béton (massif/moulé)
- Élément de maçonnerie en béton (bloc de béton)
- Brique (tous types)
- Métal (acier/aluminium, 3,3 mm d'épaisseur minimum)

**Attention!**

Risque de foudre

Si la caméra est installée dans un emplacement particulièrement exposé à la foudre, alors Bosch recommande l'installation d'un paratonnerre distinct à moins de 0,5 m et à au moins 1,5 m au-dessus de la caméra. Une connexion de terre correcte au caisson pour caméra assure une protection contre les foudroiements répétés. Le caisson pour caméra est conçu pour affronter les foudroiements répétés. Avec une protection suffisante contre la foudre, les systèmes électroniques internes ou la caméra elle-même ne devraient subir aucun dommage.



Avertissement!

Prenez garde à ne pas endommager la peinture du caisson de la caméra ou du support.



Avertissement!

La caméra doit être mise à la terre pour répondre aux normes d'immunité CEM.



Attention!

Vous pouvez monter l'appareil en orientant la tête de la caméra vers le haut ou vers le bas. Pour que l'image d'une caméra installée avec la tête vers le bas s'affiche correctement, faites pivoter l'axe d'inclinaison de la caméra de 180°. Pour plus d'informations, reportez-vous à la *Configuration de la caméra pour une utilisation à l'envers*, Page 104.



Avertissement!

Il est indispensable d'empêcher toute infiltration d'eau au niveau des connexions et de la base de la caméra. Si de l'eau parvient jusqu'au connecteur, ses broches peuvent se corroder, affectant ainsi le bon fonctionnement de la caméra. Cela est particulièrement important lorsque le sens d'orientation de la caméra est inversé.



Danger!

RISQUE D'ÉLECTROCUTION

Pour éviter tout risque d'électrocution, veuillez débrancher l'alimentation avant d'ouvrir ou de travailler sur tout bloc d'alimentation. L'alimentation doit être débranchée pour le remplacement de n'importe quel fusible dans le bloc d'alimentation MIC. Les blocs d'alimentation sont sous tension dès que le cordon d'alimentation est branché sur la source d'alimentation.

Les blocs d'alimentation MIC ont un blindage interne séparé recouvrant le bornier du câble d'alimentation (HD1). Seules les personnes suffisamment qualifiées doivent retirer ce blindage et brancher le câble secteur. Le blindage DOIT être réinstallé et parfaitement fixé avant de brancher l'alimentation.

Le câble d'alimentation doit disposer de conducteurs d'une taille maximale de 12 AWG. Un dispositif de protection des circuits de dérivation comprenant un disjoncteur bipolaire 15 A homologué ou des fusibles calibrés est requis. Un dispositif de sectionnement bipolaire facile d'accès, avec séparation des contacts de 3 mm minimum, doit être intégré de façon externe à l'équipement.



Avertissement!

Pour répondre aux normes et caractéristiques UL, tous les fils externes (d'alimentation et d'entrée/sortie) aux applications d'installation de l'unité **doivent être** acheminés séparément via différents conduits métalliques distincts, mis à la terre de manière permanente (non fournis).

**Attention!**

Mis à part la liaison à la terre, les liaisons de chauffage et les fusibles applicables, les blocs d'alimentation MIC ne comportent aucun composant susceptible d'être réparé par l'utilisateur. Les caméras MIC ne contiennent aucun élément susceptible d'être réparé par l'utilisateur.

**Attention!**

Bosch conseille d'utiliser un système d'alimentation sans coupure (UPS) avec une installation caméra MIC/bloc d'alimentation.

**Remarque!**

Pour conserver l'indice IP du boîtier du bloc d'alimentation, n'installez que des fixations ou raccords de gaine listés ou reconnus suivant les mêmes normes environnementales que le boîtier lui-même, en respectant les consignes d'installation du raccord ou de la fixation.

**Remarque!**

Reportez-vous au *Manuel d'installation du bloc d'alimentation MIC* fourni avec le bloc d'alimentation pour tout savoir sur l'installation d'un bloc d'alimentation série MIC et son raccordement à une caméra MIC.

**Remarque!**

Ne raccordez pas d'appareils MIC IR à un bloc d'alimentation MIC sur lequel l'option de chauffage est activée car cela peut endommager les caméras. Assurez-vous qu'une alimentation IR est utilisée avec une caméra MIC IR. Systèmes de chauffage disponibles pour les caméras MIC612 uniquement.

**Remarque!**

Employez exclusivement des dispositifs de décharge de traction étanches homologués UL pour les tubes électriques menant au boîtier d'alimentation. Il est essentiel que l'eau ne puisse pas pénétrer dans le boîtier. Vous devez utiliser des conduits et des raccords étanches conformes aux spécifications NEMA 6P ou aux normes IP68.

**Remarque!**

N'étirez pas, ne coupez pas et ne déplacez pas le câble de fil de terre (illustré dans la figure ci-dessous) à l'intérieur du couvercle et à la borne de terre.

**Attention!**

Seules les installations avec gaine répondent aux normes UL. Si vous choisissez d'utiliser un cordon d'alimentation sans gaine (non recommandé), installez le presse-étoupe NPT 1/2" à la place de l'obturateur. Remarque : il est plus simple de passer le cordon dans le presse-étoupe à l'extérieur du boîtier, puis de fixer le presse-étoupe au boîtier. Assurez-vous que les presse-étoupe ont suffisamment d'espace pour permettre le passage des câbles (environ 60 mm de chaque côté du boîtier).



Attention!

NE RETIREZ PAS le couvercle de la caméra et ne modifiez pas manuellement les axes d'orientation ou d'inclinaison. Cela entraînerait l'annulation de la garantie. La modification manuelle des axes pourrait également endommager la denture de l'engrenage.



Attention!

Le blindage Biphase doit être connecté à l'équipement en amont uniquement.



Remarque!

Ce produit est un appareil de **classe A**. Utilisé dans le cadre d'une installation domestique, il peut provoquer des interférences radio. Le cas échéant, l'utilisateur devra prendre les mesures adéquates.



Remarque!

Ce produit est un appareil de **classe A**. Son utilisation dans une zone résidentielle risque de provoquer des interférences. Le cas échéant, l'utilisateur devra prendre les mesures nécessaires pour y remédier.

Informations FCC et ICES

(Modèles américains et canadiens uniquement)

Ce dispositif est conforme aux exigences imposées par la section 15 du règlement de la Commission fédérale des communications des États-Unis (FCC). Son utilisation est soumise aux deux conditions suivantes :

- ce dispositif ne doit pas provoquer d'interférences nuisibles, et
- ce dispositif doit supporter toutes les interférences reçues, dont les interférences susceptibles d'entraîner un fonctionnement imprévu.

REMARQUE : Suite à différents tests, cet appareil s'est révélé conforme aux exigences imposées aux appareils numériques de **Classe A** en vertu de la section 15 du règlement de la Commission fédérale des communications des États-Unis (FCC) et en vertu de la norme ICES-003 d'Industrie Canada. Ces contraintes sont destinées à fournir une protection raisonnable contre les interférences nuisibles quand l'appareil est utilisé dans une **installation commerciale**. Cet appareil génère, utilise et émet de l'énergie de radiofréquences et peut, en cas d'installation ou d'utilisation non conforme aux instructions, engendrer des interférences nuisibles au niveau des radiocommunications. L'utilisation de cet appareil dans une zone résidentielle risque de provoquer des interférences nuisibles. Le cas échéant, l'utilisateur devra remédier à ces interférences à ses propres frais.

Toute modification apportée au produit et non expressément approuvée par la partie responsable de la conformité de l'appareil est strictement interdite. Une telle modification est susceptible d'entraîner la révocation de l'autorisation d'utilisation de l'appareil. Au besoin, l'utilisateur consultera son revendeur ou un technicien qualifié en radio/télévision, qui procédera à une rectification.

La brochure suivante, publiée par la Commission fédérale des communications (FCC), peut s'avérer utile : « How to Identify and Resolve Radio-TV Interference Problems » (Comment identifier et résoudre les problèmes d'interférences de radio et de télévision). Cette brochure est disponible auprès du Government Printing Office, Washington, DC 20402, États-Unis, sous la référence n° 004-000-00345-4.

Clause de non-responsabilité UL

Underwriter Laboratories Inc. (« UL ») n'a pas testé les performances ni la fiabilité des aspects sécurité ou signalisation de ce produit. UL a uniquement testé les risques d'incendie, d'électrocution et/ou de blessure, tels que décrits dans Standard(s) for Safety for Information Technology Equipment, UL 60950-1 . La certification UL ne s'applique ni aux performances ni à la fiabilité des aspects de sécurité et de signalisation de ce produit.

UL EXCLUT TOUTE RESPONSABILITÉ, GARANTIE OU CERTIFICATION, QUANT AUX PERFORMANCES OU À LA FIABILITÉ DES FONCTIONS DE CE PRODUIT LIÉES À LA SÉCURITÉ ET À LA SIGNALISATION.

1.6 Informations de sécurité spécifiques pour la Protection contre les explosions



Avertissement!

N'OUVREZ PAS LE CAISSON DU PRODUIT !

Aucune réparation impliquant l'ouverture du caisson du produit n'est autorisée.

Le non-respect de cette précaution entraînera l'annulation de la certification et de la garantie.

Le produit est homologué pour une utilisation à des températures comprises entre -20 et +60 °C et il ne doit pas être utilisé en dehors de ces plages.

La certification de cet appareil dépend de la maintenance des chemins de flamme et de l'utilisation des matériaux suivants dans la construction de zones exposées : aluminum (BS-EN755 1997 6082T6) ; acier inoxydable (BS-EN10088 No.1.4404). Les écarts construction maximum (Ic) des chemins de flamme cylindriques sont inférieurs à ceux requis par le Tableau A de la norme EN 60079-1:2007, comme indiqué ci-dessous :

Chemin de flamme	Écart maximum (mm)
Entre le trou central d'inclinaison et la tige de caisson de support d'inclinaison (2 désactivé)	0.089
Entre le trou du bras d'étrier et la tige « resolver » d'inclinaison	0.061
Entre le trou du bras d'étrier et la tige du capuchon obturateur du bras d'étrier	0.061
Entre le trou du bras d'étrier et la tige du raccord d'étrier	0.061
Entre le trou supérieur de la partie orientable et la tige de raccord d'étrier (2 désactivé)	0.061
Entre le trou de couvercle supérieur et la tige de montage du moteur d'essuie-glace	0.060
Entre le trou du moteur d'essuie-glace et la tige de la bride de montage	0.100

La partie orientable et la partie supérieure de la partie orientable doivent être fixés avec des vis spéciales à tête d'assemblage M5 - longueur 0,8 x 10 mm S316, acier inoxydable, type A4/70.

Avertissement!

Prenez les précautions appropriées si la caméra est susceptible d'entrer en contact avec des substances agressives.



Si l'appareil est susceptible d'entrer en contact avec des substances agressives (par exemple, des liquides ou gaz acides pouvant attaquer les métaux, ou des solvants pouvant affecter des matériaux polymérisés), il est de la responsabilité de l'utilisateur de prendre les précautions nécessaires pour éviter un tel contact, et de s'assurer que le type de protection fourni avec l'équipement est approprié. Précautions à suivre : contrôles réguliers dans le cadre d'inspections de routine ou établissement de fiches techniques pour les substances chimiques.

La caméra est conçue pour une utilisation avec des gaz et vapeurs inflammables avec un appareil des groupes IIA, IIB et IIC, et avec les classes de température T1 à T6.

Les unités doivent porter la marque de certification suivante : **SIRA05ATEX1300X Exd IIC T6 Ta -20° à +60° C Gb.**

Directives CE

Cette caméra MIC est conforme aux directives CE suivantes :

- Directive ATEX (2014/34/UE)
- Directive EMC (2014/30/UE)
- Directive machines (2006/42/CE)
- Directive Basse Tension (2014/35/UE)
- Directive 2011/65/CE relative à la RoHS (restriction de l'utilisation de substances dangereuses)
- Directive 2002/96/CE relative aux DEEE (déchets d'équipements électriques et électroniques)

1.7 Assistance technique et service à la clientèle

Si l'unité doit être réparée, contactez le centre de réparation Bosch Security Systems le plus proche pour obtenir une autorisation de retour d'article et les consignes d'expédition.

Centres de réparation

États-Unis

Tél. : +1 800-366-2283 ou +1 585-340-4162

Fax : +1 800-366-1329

E-mail : cctv.repair@us.bosch.com

Service clientèle

Tél. : +1 888-289-0096

Fax : +1 585-223-9180

E-mail : security.sales@us.bosch.com

Support technique

Tél. : +1 800-326-1450

Fax : +1 585-223-3508 ou +1 717-735-6560

E-mail : technical.support@us.bosch.com

Centre de réparation

Tél. : +1 585-421-4220

Fax : +1 585-223-9180 ou 717-735-6561

E-mail : security.repair@us.bosch.com

Canada

Tél. : +1 514-738-2434

Fax : +1 514-738-8480

Europe, Moyen-Orient, Afrique

Contactez votre distributeur ou votre représentant Bosch local. Utilisez le lien :
<http://www.boschsecurity.com/startpage/html/europe.htm>

Région Asie-Pacifique

Contactez votre distributeur ou votre représentant Bosch local. Utilisez le lien :
http://www.boschsecurity.com/startpage/html/asia_pacific.htm

Informations supplémentaires

Pour plus d'informations, contactez votre organisation Bosch Security Systems la plus proche, ou consultez notre site Web à l'adresse www.boschsecurity.fr/www.boschsecurity.be

Bosch Security Systems B.V.

Torenallee 49
5617 BA Eindhoven
Netherlands

www.boschsecurity.com

© Bosch Security Systems B.V., 2016

