

# Eaton's Innovative Technology XT surge protective device



In today's business environment that calls for 24 hours a day, 7 days a week uptime and reliability, Eaton's Innovative Technology® XT50 and XT100 surge protective devices (SPDs) ensure that a customer's investment in equipment and processes is protected from the damaging effects of voltage transients. Designed for installation on service entrance, branch panels or individual equipment disconnects, the XT50/100 provides enhanced surge protection for mission-critical applications.

## Features

- Self-protected metal oxide varistor technology
- Rated 50 kA (XT50) or 100 kA (XT100) peak surge current
- Wide range of voltage applications from 100 to 600 Vac
- Wiring systems: single-phase, split-phase, three-phase wye or three-phase delta
- High-intensity LED phase status indicators
- NEMA® 4X (IP56) polycarbonate enclosure
- Space-saving design takes up less than 27 square inches of panel space
- #10 AWG (6 mm<sup>2</sup>) stranded wire included
- 0.75-inch threaded conduit fitting included
- Optional external mounting feet
- Can be used for UL 96A compliance
- Can be used for UL NFPA compliance
- Can be used for RoHS compliance

## Product application

Eaton's XT series of SPDs are designed for medium- and low-exposure level applications that require cost-effective, high-quality system protection including:

- Residential/small business
- Light industrial
- Light commercial
- Service entrance and branch panel protection

## Installation recommendations

When installing an SPD, it is important to mount the unit as close to the electrical equipment as possible, to keep the wiring (lead length) between the electrical equipment and the SPD as short as possible, and to twist/tie the conductors together to reduce the wire's inductive effects.

## Surge protection from the inside out

The XT series of surge protective devices are the first SPDs offered by Eaton's Innovative Technology to make use of self-protected metal oxide varistors that provide both high energy capacity and fail-safe operation. This technology, which uses a special low-temperature solder on each individual MOV, can sustain high surge currents and provide the necessary interruption of high fault currents (kAIC). The low-temperature solder functions to disconnect a failed MOV at its end-of-life, or before the MOV exceeds an unsafe temperature during low-level fault current events. Low-level fault currents are most common during temporary over-voltage conditions (TOV) and are the main cause of surge protective device failure.

SPD products that promote fuses with excessive surge current ratings do not provide the proper system coordination. They sacrifice low-level fault protection and in most cases do not disconnect during low current fault events. This can result in catastrophic failure (fire) and eventual tripping of the upstream breaker or fuse. With the XT50/100, you get both safety and system coordination.

Let-through voltage is a key performance measurement for SPDs. The most significant factor affecting let-through voltage is lead length. The XT's small size allows the device to be installed as close as possible to the equipment being protected. By minimizing the lead length, let-through voltage is reduced and performance is enhanced.



*Powering Business Worldwide*

## Specifications

Description	Specifications
Peak surge current	
XT50	50 kA peak per phase
XT100	100 kA peak per phase
Nominal discharge current	20 kA ①
Short-circuit current rating	100 kA
System voltages (Vac)	
Direct current ②	48, 125
Single-phase	200, 208, 220, 230, 240, 277, 480
Split-phase	100/200, 110/220, 120/240
Three-phase wye	100/175, 110/190, 120/208, 127/220, 220/380, 230/400, 240/415, 277/480, 305/525, 347/600
Three-phase delta	200, 208, 220, 230, 240, 380, 400, 415, 440, 480, 525, 600
Three-phase high leg delta	240
Input power frequency	47 to 420 Hz (50/60 Hz typical)
Protection modes	
Single-phase	L-N, L-G, N-G
Split-phase	L-N, L-G, L-L, N-G
Three-phase wye	L-N, L-G, L-L, N-G
Three-phase delta	L-G, L-L
Connection	#10 AWG (6 mm <sup>2</sup> )
Diagnostics	LED indicators, 1 per phase
Operating temperature	-13 °F to +140 °F (-25 °C to +60 °C)
Number of ports	1
Specific energy	100 kJ/ohm
Enclosure	NEMA 4X (IP56) polycarbonate
Mounting	Threaded 0.75-inches conduit fitting and multi-point mounting holes
Weight	≈2 lb (1.0 kg)
Vibration	Tested to IEC 60255-21-1 and -2

① 480L, 600D and 600Y units rated 10 kA I<sub>n</sub>.

② DC models only available in 50 kA.

## Standards, certifications and warranty

- UL® 1449 4th Edition and UL 1283 7th Edition listed
- CE and CSA® marked
- Five-year free replacement



## Standard dimensions

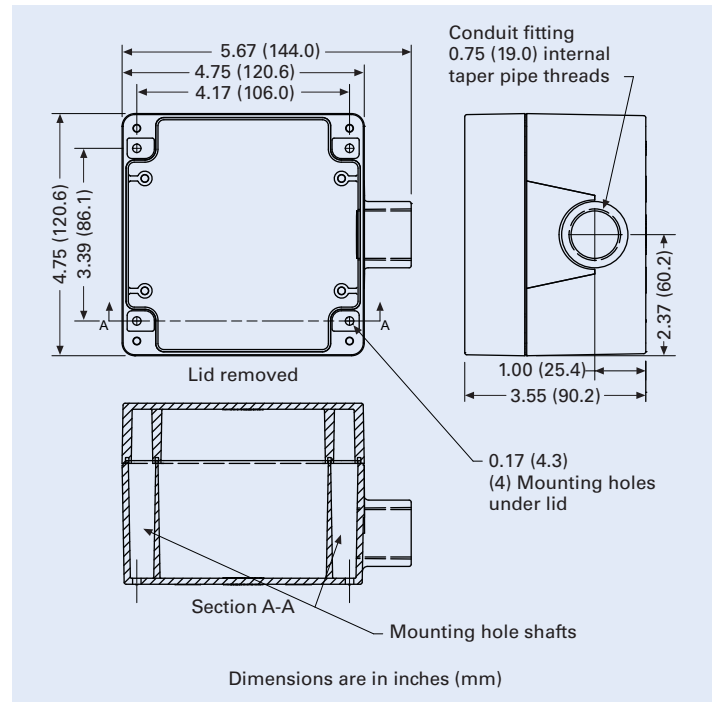

## Ordering guidelines

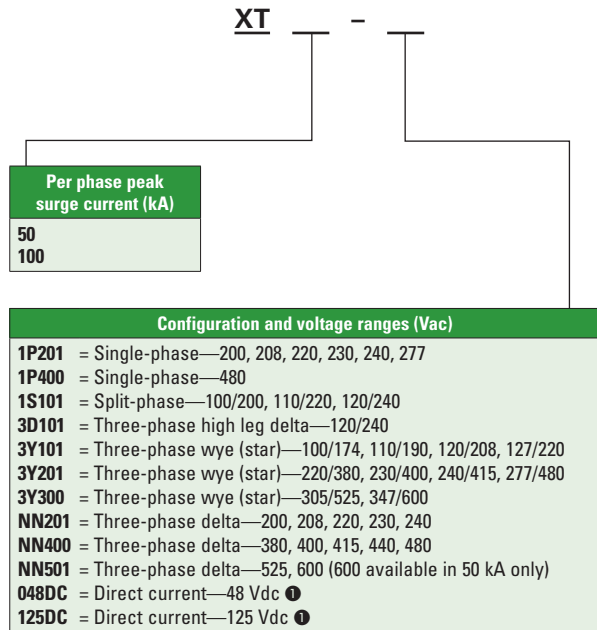

① DC models only available in 50 kA.

## XT50/100 accessories

Description	Catalog number
External mounting feet	<b>MNTGFTX</b>
Flush-mount plate	<b>FLUSHMNTPLATE12</b>

**Eaton**  
1000 Eaton Boulevard  
Cleveland, OH 44122  
United States  
Eaton.com

© 2018 Eaton  
All Rights Reserved  
Printed in USA  
Publication No. PA01006004E / Z21664  
November 2018

**EATON**  
Powering Business Worldwide

Eaton is a registered trademark.

All other trademarks are property of their respective owners.

Follow us on social media to get the latest product and support information.

