



# Installation, Operation, and Maintenance

---

## Midrange Self-Contained Units



Models SCWH/SIWH/SCRH/SIRH  
3, 5, 7.5, 10, 12, & 15-tons

"AO" and later design sequence

## About This Manual Literature Change History

Use this manual for commercial self-contained models SCWH, SIWH, SCRH, and SIRH. This is the original issue of this manual. It provides specific installation, owner maintenance, and diagnostic troubleshooting instructions for "AO" and later design sequences.

**Note: The procedures discussed in this manual should only be performed by qualified, experienced HVAC technicians.**

**Note: This document is customer property and must be retained for use by maintenance personnel.**

It is important to perform periodic maintenance to help ensure trouble free operation. Should equipment failure occur, contact a qualified Trane service organization for an experienced HVAC technician to properly diagnose and repair this equipment.

## Warnings and Cautions

Warnings and cautions appear at appropriate sections throughout this manual. Read these carefully.

### WARNING

Indicates a potentially hazardous situation, which could result in death or serious injury if not avoided.

### CAUTION

Indicates a potentially hazardous situation, which may result in minor or moderate injury if not avoided. Also, it may alert against unsafe practices.

### CAUTION

Indicates a situation that may result in equipment or property-damage-only accidents.

## Example Warnings and Cautions

### WARNING

**Hazardous Voltage!**  
Disconnect all electric power, including remote disconnects before servicing. Follow proper lockout/tagout procedures to ensure power cannot be inadvertently energized. Failure to disconnect power before servicing could result in death or serious injury.

### CAUTION

**Use Copper Conductors Only!**  
Unit terminals are not designed to accept other type conductors. Failure to use copper conductors may result in equipment damage.

## Common HVAC Acronyms

For convenience, a number of acronyms and abbreviations are used throughout this manual. These acronyms are alphabetically listed and defined below.

CFM = Cubic-feet-per-minute  
CKT. = Circuit  
CV = Constant volume  
CW = Clockwise  
CCW = Counterclockwise  
E/A = Exhaust air  
F/A = Fresh air  
HGBP = Hot gas bypass  
HVAC = Heating, ventilation and air conditioning  
IGV = Inlet guide vanes  
I/O = Inputs/outputs  
IOM = Installation/operation/maintenance manual  
LH = Left-hand  
O/A = Outside air  
psig = Pounds-per-square-inch, gauge pressure  
R/A = Return air  
RH = Right-hand  
RPM = Revolutions-per-minute  
S/A = Supply air  
SZ = Single-zone (unit airflow)  
VAV = Variable air volume  
w.c. = Water column

## Special Note on Refrigeration Emissions

World environmental scientists have concluded that ozone in our upper atmosphere is being reduced due to the release of CFC fully halogenated compounds.

Trane urges all HVAC service personnel to make every effort to prevent any refrigerant emissions while installing, operating, or servicing equipment. Always conserve refrigerants for continued use.

# contents

---

**Cross reference to related publications/information:**  
*Midrange Self-Contained catalog, PKG-PRC012-EN*

<b>Installation.....</b>	<b>2</b>
general information .....	2
pre-installation considerations .....	6
dimensions & weights .....	11
mechanical requirements .....	17
electrical requirements .....	19
installation procedure .....	21
pre-startup requirements .....	22
startup .....	23
<b>Operation.....</b>	<b>24</b>
sequence of operation .....	24
<b>Maintenance .....</b>	<b>25</b>
general information .....	25
maintenance procedures .....	26
periodic checklists .....	29
troubleshooting .....	30
typical wiring diagrams .....	32

# Installation general information

## Midrange Model Number Description

Following is a complete description of the midrange model number. Each digit in the model number has a corresponding code that identifies specific unit options.

S C W H 075 4 2 A0 1 0 1 0  
1 2 3 4 567 8 9 1011 12 13 14 15

### Digit 1 - unit model

S = self contained

### Digit 2 - unit type

C = commercial

I = industrial

### Digit 3 - condenser medium

R = remote air-cooled

W = water cooled

### Digit 4 - development sequence

H = development series

### Digit 5, 6, 7- unit nominal capacity

030 = 3 tons

050 = 5 tons

075 = 7.5 tons

100 = 10 tons

120 = 12 tons

150 = 15 tons

### Digit 8 - unit voltage

3 = 208 - 230 volt/60 hz/3 ph

4 = 460 volt/60 hz/3 ph

5 = 575 volt/60 hz/3 ph

### Digit 9 - air flow configuration

2 = vertical discharge / front return

3 = vertical discharge / rear return

### Digit 10, 11 - design sequence

A0 = design sequence

### Digit 12 - air filter type

1 = one-inch fiberglass throwaway

### Digit 13 - control

0 = control interface

### Digit 14 - unit finish

1 = painted

2 = corrosion resistant coating

### Digit 15 - coil finish

0 = none

E = evaporator coated

## Unit Airflow Configurations

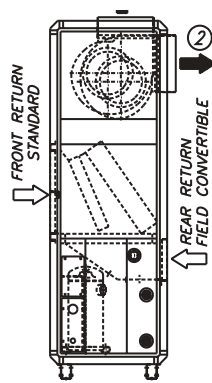

model 030/050/750

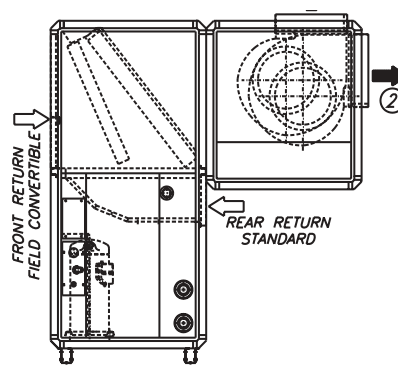

model 100/120/150

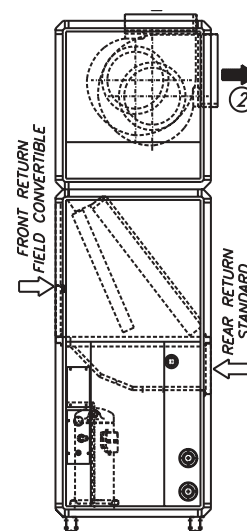

	unit size	discharge	fan location	comments
①	030/050/075	vertical CCW	top	standard
②		horizontal CW	top	field converted
③	100/120/150	vertical CCW	top	standard
④		vertical CW	top	field converted
⑤		horizontal CW	top	
⑥		vertical CW	rear	
⑦		horizontal CW	rear	
⑧		horizontal CCW	rear	

# Installation

## General

The midrange models SCWH/SCRH/SIWH/SIRH is a high efficiency, vertical air conditioner. units have either front or top discharge configuration options and easy service access. Unit construction is heavy gage steel with a baked enamel finish. Available unit voltages are 208/3/60, 230/3/60, 460/3/60, and 575/3/60.

### Refrigeration Circuits

Units are configured in single or double refrigeration circuits. Each circuit consists of:

- high efficiency scroll compressor mounted on rubber isolation grommets
- evaporator coils designed for optimum performance and efficiency with lanced fins and rifled tubing
- filter-drier

### Evaporator Section

The evaporator fan section consists of one or two forward curved centrifugal fans powered by a premium efficiency motor through an adjustable motor sheave and fixed diameter blower pulley.

### Controls

The standard control panel consists of a high voltage terminal block, overload relays for each fan motor, transformer, 3-pole 24-volt contactors for each motor and compressor, and a 5-second delay timer. Remote thermostat controls are field installed.

### Field-Installed Accessories

These items ship separately for field installation:

- steam coil
- hot water coil
- plenum
- oversized motors
- remote thermostat

**Note: Application of the above options and/or accessories may require field adjustment of fan speeds to ensure proper airflow and performance.**

### Unit Nameplate

The unit nameplate identifies the unit model number, appropriate service literature, and wiring diagram numbers. It is mounted on the control panel door. Reference this information when making inquiries or ordering parts or literature.

## Refrigerant Handling Procedures

### Environmental Accountability Policy

Trane urges that all HVAC servicers to make every effort to eliminate, if possible, or vigorously reduce the emission of CFC, HCFC, and HFC refrigerants to the atmosphere. Always act in a responsible manner to conserve refrigerants for continued usage even when acceptable alternatives are available.

### Recover and Recycle Refrigerants

Never release refrigerant to the atmosphere! Always recover and/or recycle refrigerant for reuse, reprocessing (reclaimed), or properly dispose if removing from equipment. Always determine the recycle or reclaim requirements of the refrigerant before beginning the recovery procedure. Obtain a chemical analysis of the refrigerant if necessary. Questions about recovered refrigerant and acceptable refrigerant quality standards are addressed in ARI Standard 700.

### Refrigerant Handling and Safety

Consult the manufacturer's material safety data sheet (MSDS) for information on refrigerant handling to fully understand health, safety, storage, handling, and disposal requirements. Use the approved containment vessels and refer to appropriate safety standards. Comply with all applicable transportation standards when shipping refrigerant containers.

### Service Equipment and Procedures

To minimize refrigerant emissions while recovering refrigerant, use the manufacturer's recommended recycling equipment per the MSDS. Use equipment and methods which will pull the lowest possible system vacuum while recovering and condensing refrigerant. Equipment capable of pulling a vacuum of less than 1,000 microns of mercury is recommended.

Do not open the unit to the atmosphere for service work until refrigerant is fully removed/recovered. When leak-testing with trace refrigerant and nitrogen, use HCFC-22 (R-22) rather than CFC-12 (R-12) or any other fully-halogenated refrigerant. Be aware of any new leak test methods which may eliminate

refrigerants as a trace gas. Perform evacuation prior to charging with a vacuum pump capable of pulling a vacuum of 1,000 microns of mercury or less. Let the unit stand for 12 hours and with the vacuum not rising above 2,500 microns of mercury.

A rise above 2,500 microns of mercury indicates a leak test is required to locate and repair any leaks. A leak test is required on any repaired area.

Charge refrigerant into the equipment only after equipment does not leak or contain moisture. Reference proper refrigerant charge requirements in the maintenance section of this manual to ensure efficient machine operation. When charging is complete, purge or drain charging lines into an approved refrigerant container. Seal all used refrigerant containers with approved closure devices to prevent unused refrigerant from escaping to the atmosphere. Take extra care to properly maintain all service equipment directly supporting refrigerant service work such as gauges, hoses, vacuum pumps, and recycling equipment.

When cleaning system components or parts, avoid using CFC-11 (R-11) or CFC-113 (R-113). Use only cleaning-solvents that do not have ozone depletion factors. Properly dispose of used materials. Refrigeration system cleanup methods using filters and driers are preferred. Check for leaks when excessive purge operation is observed.

Keep abreast of unit enhancements, conversion refrigerants, compatible parts, and manufacturer's recommendations that will reduce refrigerant emissions and increase equipment operating efficiencies.



# pre-installation considerations

## Installation

### Pre-Installation Considerations

#### Pre-Installation Checklist

Complete the following checklist before beginning unit installation.

- Verify the unit size and tagging with the unit nameplate.
- Make certain the floor or foundation is level, solid, and sufficient to support the unit and accessory weights. Level or repair the floor before positioning the unit if necessary.
- Allow minimum recommended clearances for routine maintenance and service. Refer to unit submittals for dimensions.
- Allow three fan diameters above the unit for the discharge ductwork. Return air enters the rear of the unit and conditioned supply air discharges through the top.
- Electrical connection knockouts are on the top, left side of the unit.
- Allow adequate space for piping access and panel removal. Condenser water piping, refrigerant piping, and condensate drain connections are on the lower left end panel.
- Electrical supply power must meet specific balance and voltage requirements as described in the "Electrical Requirements" section.
- Water-cooled units only: The installer is responsible for providing a condenser main, standby water pump, cooling tower, pressure gauges, strainers, and all components for waterside piping. See the "Water Piping" section for general waterside recommendations.
- Air-cooled units only: The installer is responsible for providing and installing the remote air-cooled condenser and refrigerant piping, including filter driers.

### Receiving and Handling

#### Shipping Package

Midrange units ship assembled on skids. Units ship assembled, piped, and charged with either R410a (models SCWH/SIWH) or a dry nitrogen charge (models SCRH/SIRH).

#### Receiving Checklist

Complete the following checklist immediately after receiving unit shipment to detect possible shipping damage.

- Inspect individual cartons before accepting. Check for rattles, bent carton corners, or other visible indications of shipping damage.
- If a unit appears damaged, inspect it immediately before accepting the shipment. Make specific notations concerning the damage on the freight bill. Do not refuse delivery.
- Inspect the unit for concealed damage before it is stored and as soon as possible after delivery. Report concealed damage to the freight line within the allotted time after delivery. Check with the carrier for their allotted time to submit a claim.
- Do not move damaged material from the receiving location. It is the receiver's responsibility to provide reasonable evidence that concealed damage did not occur after delivery.
- Do not continue unpacking the shipment if it appears damaged. Retain all internal packing, cartons, and crate. Take photos of damaged material if possible.
- Notify the carrier's terminal of the damage immediately by phone and mail. Request an immediate joint inspection of the damage by the carrier and consignee.
- Notify your Trane representative of the damage and arrange for repair. Have the carrier inspect the damage before making any repairs to the unit.

#### Unit Storage

Take precautions to prevent condensate from forming inside the electrical compartments and motors if the unit is stored before it is installed.

#### Service Access

Maintain adequate clearances around and above the unit to ensure proper unit operation and allow sufficient service access. Trane recommends 36-inches service access on all sides of the unit. Service access locations are shown in figures on pages 8 through 9.

#### WARNING

##### *Hazardous Voltage!*

Disconnect all electric power, including remote disconnects before servicing. Follow proper lockout/tagout procedures to ensure power cannot be inadvertently energized. Failure to disconnect power before servicing could result in death or serious injury.

### Installation Preparation

Before installing the unit, perform the following procedures to ensure proper unit operation.

1. Verify the floor or foundation is level. Shim or repair as necessary. To ensure proper unit operation, install the unit level in both horizontal axes.
2. Allow adequate service and code clearances as recommended in "Service Access" section. Position the unit and skid assembly in its final location. Test lift the unit to determine exact unit balance and stability before hoisting it to the installation location. See the "Proper Lifting Procedure" section for proper rigging procedures and cautions.
3. Remove the skids from under the unit. If you find internal damage, file a claim immediately to the delivering carrier.
4. Remove the protective shipping covers from the unit.
5. Verify the compressor isolator shipping brackets are removed and the isolators are properly tightened for operation.

# Installation

## pre-installation considerations

### Service Access

#### 3 through 7.5-ton SCRH/SIRH/SCWH/SIWH

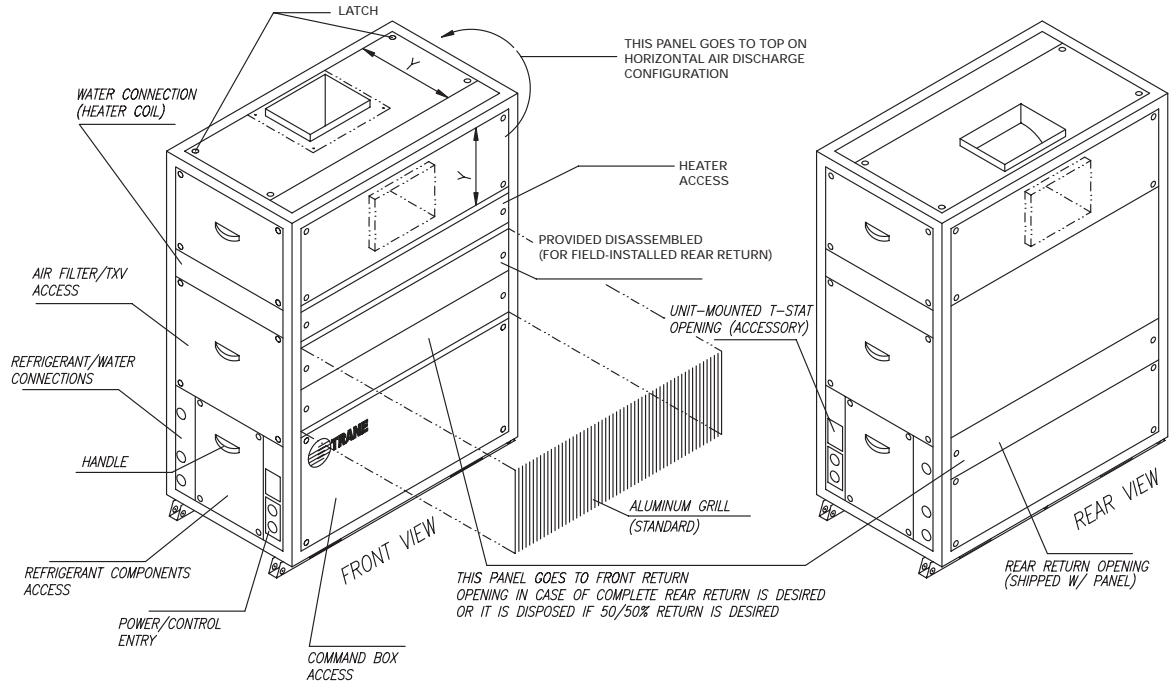

#### 3 through 15-ton SCWH/SIWH/SRCH/SIRH with top-mounted fan configuration

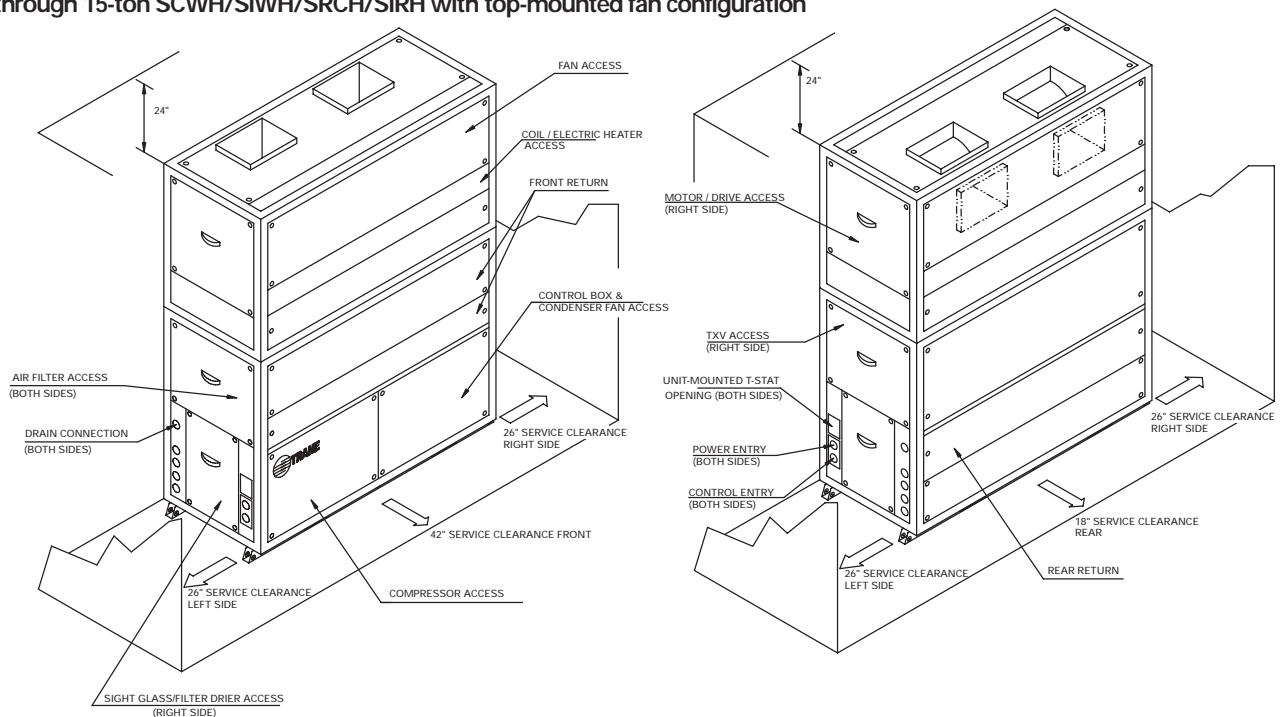



# Installation

# pre-installation considerations

## Service Access

10 through 15-ton SCRH/SIRH/SCWH/SIWH

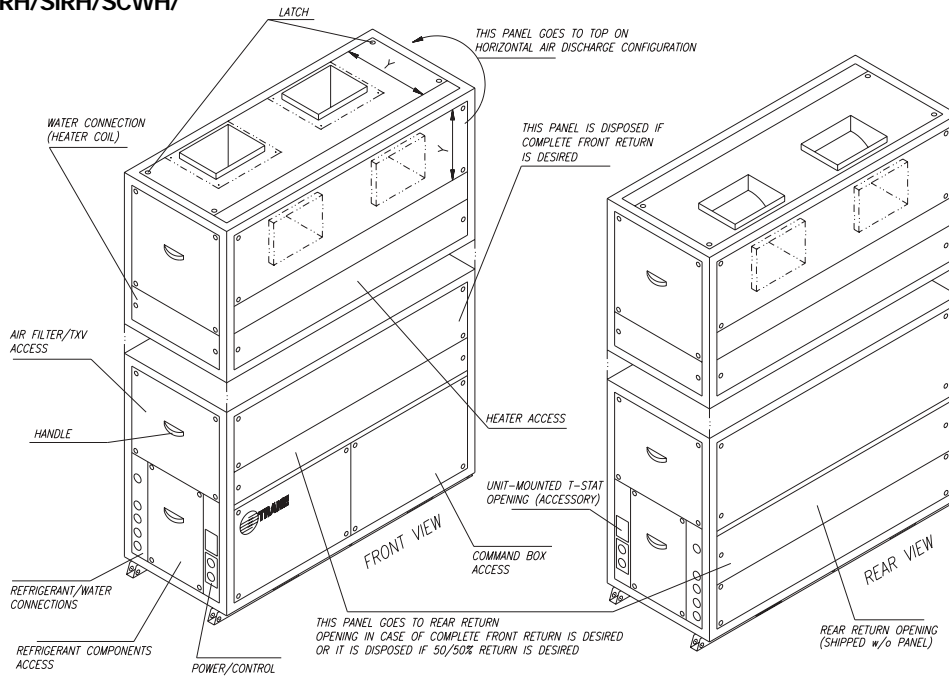

10, 12, & 15-ton SCWH/SIWH/SRCH/SIRH with side-mounted fan configuration, field converted

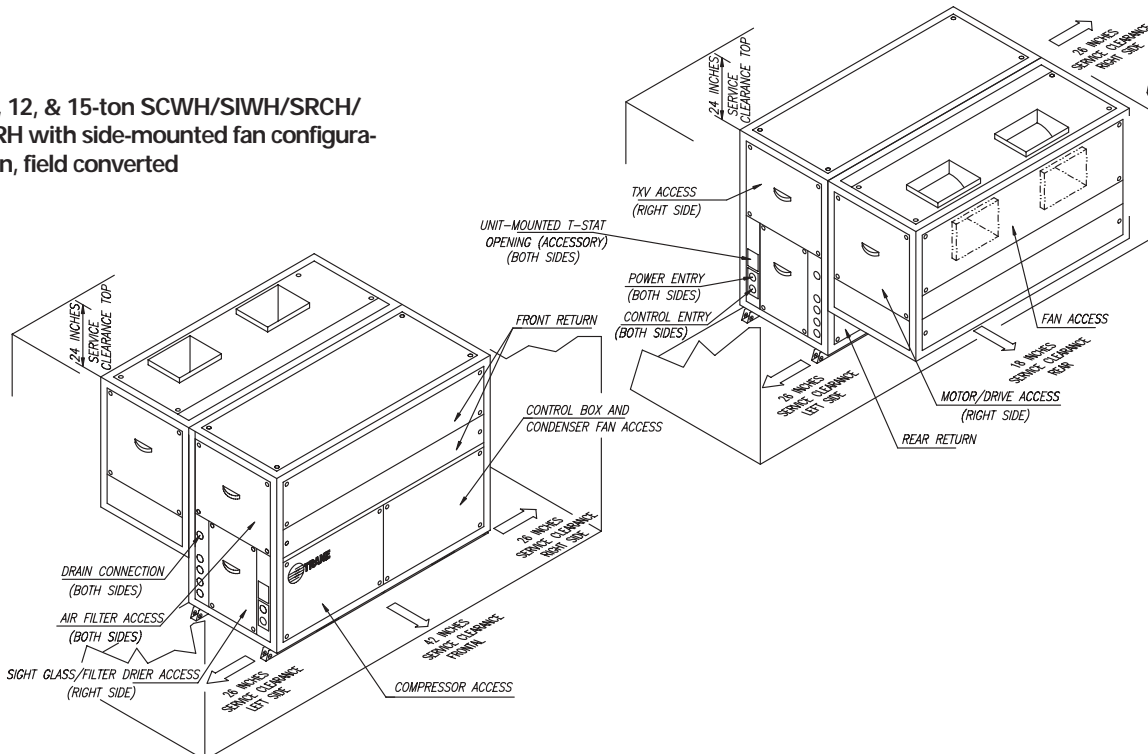



# Installation

# pre-installation considerations

## Isolator Placement

**Note: Isolators are field-provided.**

**Table I-PC-1. Isolator load points, units with a vertical discharge configuration, lbs.**

model	SCRB/SIRB				SCWB/SIWB			
	L1	L2	L3	L4	L1	L2	L3	L4
3-ton	99	105	120	127	105	133	118	124
5-ton	115	122	157	166	129	165	166	165
7.5-ton	154	203	227	221	177	234	230	231
10-ton	208	266	273	253	263	334	293	300
15-ton	243	332	359	356	315	388	382	375

**Table I-PC-2. Isolator load points, units with a horizontal discharge configuration, lbs.**

model	SCRB/SIRB				SCWB/SIWB			
	L1	L2	L3	L4	L1	L2	L3	L4
7.5-ton	250	108	313	135	285	126	319	140
10-ton	318	150	363	169	383	211	383	211
15-ton	404	166	510	210	514	215	514	215

**Table I-PC-3. Isolator load points & types, units with a horizontal discharge, inverted "L" configuration, lbs.**

	air-cooled models				water-cooled models			
	L1	L2	L3	L4	L1	L2	L3	L4
<b>10-ton unit</b>	318	150	363	169	383	211	383	211
spring	red	yellow	red	yellow	red	yellow	red	yellow
rubber-in-shear	green	red	green	red	green	red	green	red
<b>15-ton unit</b>	404	166	510	210	514	215	514	215
spring	purple	yellow	purple	yellow	purple	yellow	purple	yellow
rubber-in-shear	gray	red	gray	red	gray	red	gray	red

Note: Units ship with two different color isolators and should be placed as depicted in this chart to properly support the unit weight. See Figures I-PC-1 & I-PC-2 for correct isolator positions by unit size.

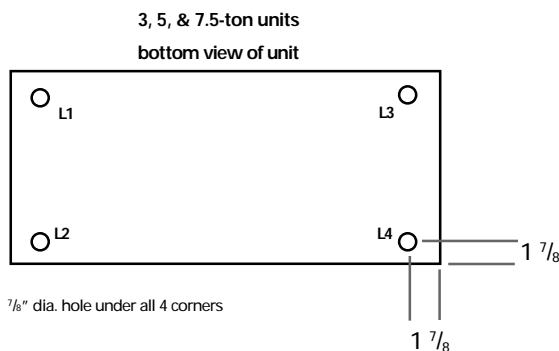

**Figure I-PC-1. Isolator mounting hole locations on 3, 5, & 7.5-ton units**

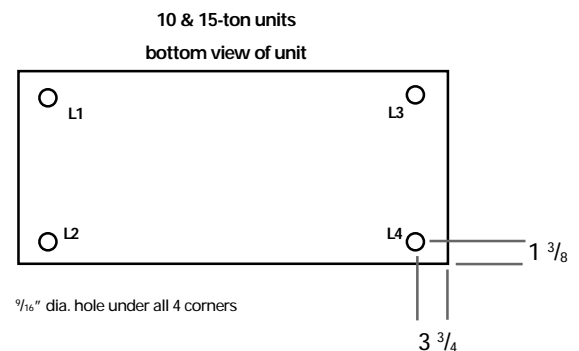

**Figure I-PC-2. Isolator mounting hole locations on 10 & 15-ton units**

# Installation

**⚠ WARNING*****Improper Unit Lift!***

Test lift unit approximately 24 inches high to verify the proper center-of-gravity lift point. To avoid dropping the unit, reposition the lifting point if the unit is not level. Failure to properly lift the unit could result in death, serious injury, or possible equipment/property-only damage.

**Proper Lifting Procedure**

Follow these instructions and reference Figure I-PC-3.

1. Slide a fork lift into the opening provided on the unit base. Move the fork lift carefully.
2. Using slings, attach through the circular holes provided on the unit base. Protect the unit from damage by rigging equipment.

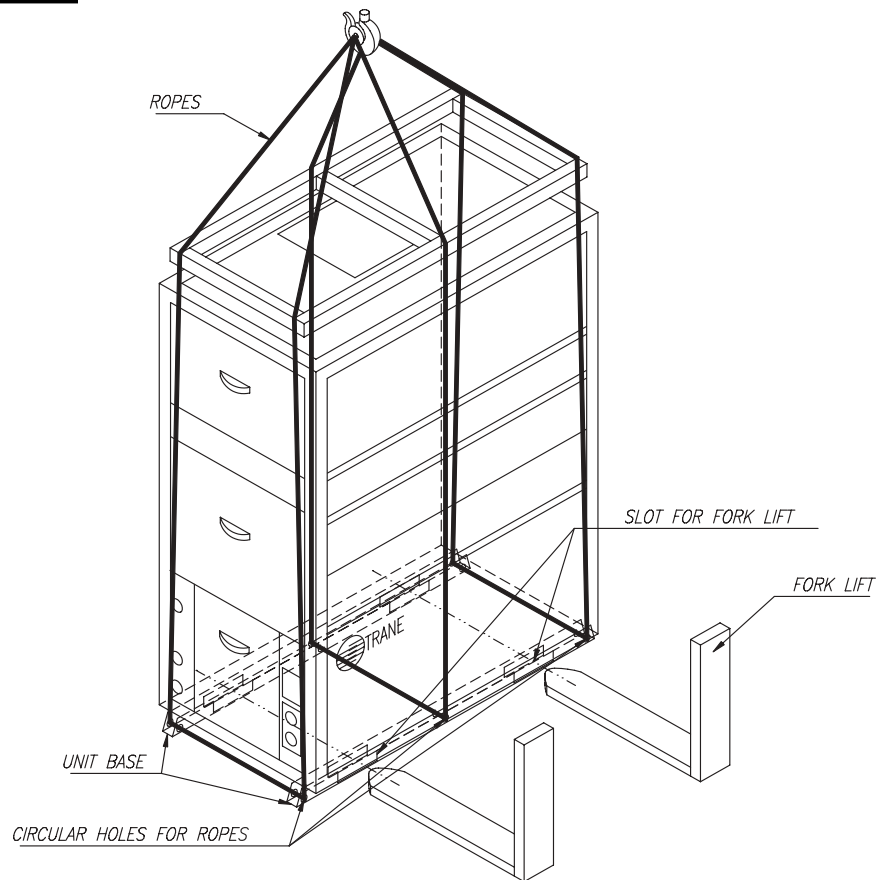
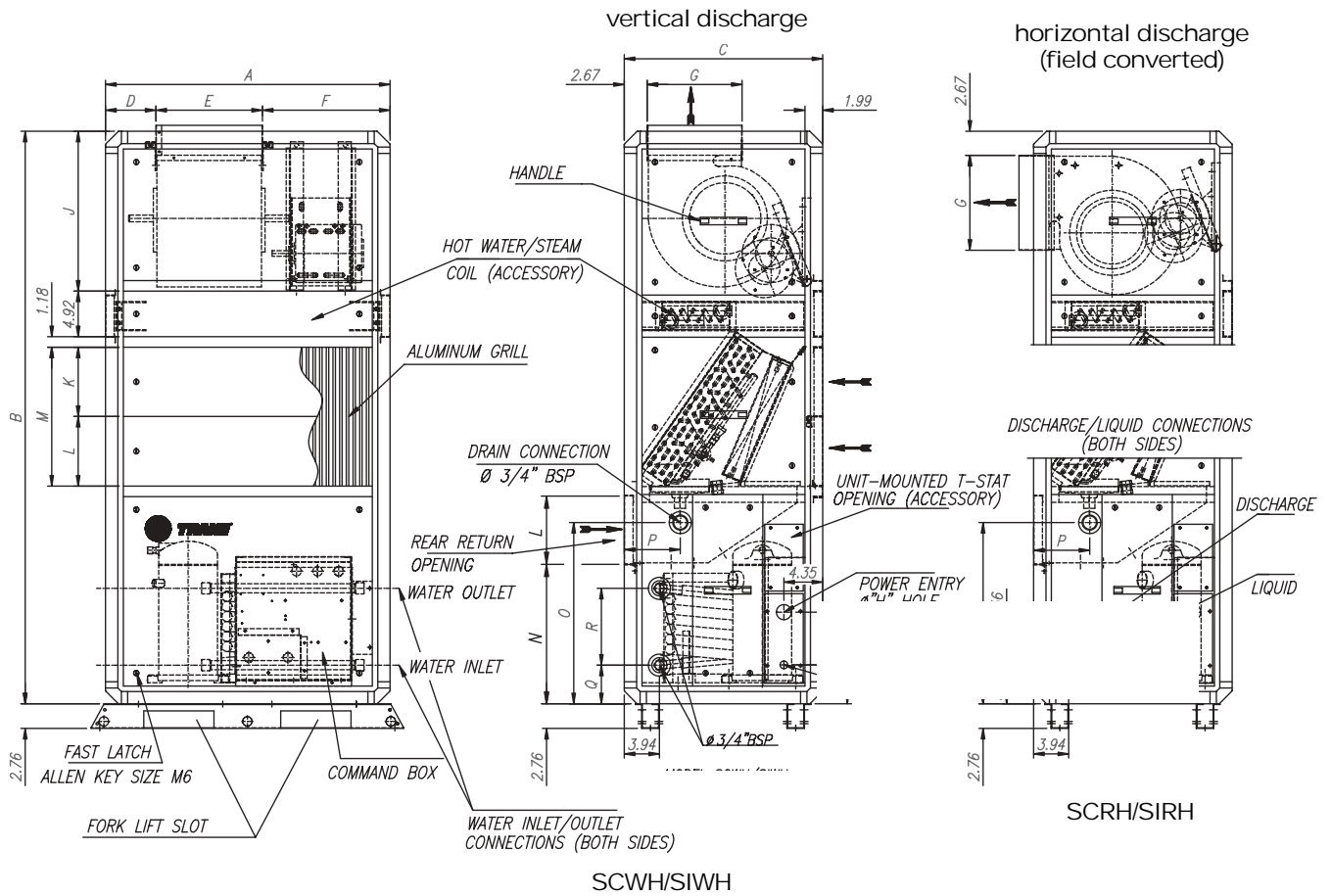

*Figure I-PC-3. Proper unit lifting procedure*

# Installation

# dimensions & weights

## 3 & 5-tons SCWH/SIWH/SCRH/SIRH



**SCWH/SIWH/SCRH/SIRH dimensions & weight, in-lbs.**

unit size	A	B	C	D	E	F	G	J	K	L	M	N	O	P	Q	R	S	shipping weight	operating weight
3	31.89	64.17	22.24	5.65	11.93	14.31	10.63	18.00	7.80	7.80	15.60	15.63	20.20	6.28	4.33	8.58	4.37	494	459
5	36.41	75.98	24.01	7.73	13.03	15.65	11.61	20.31	12.32	8.66	20.98	18.58	24.20	7.10	5.43	6.38	7.12	592	555



# Installation

# dimensions & weights

## 7.5-tons SCWH/SIWH/SCRH/SIRH

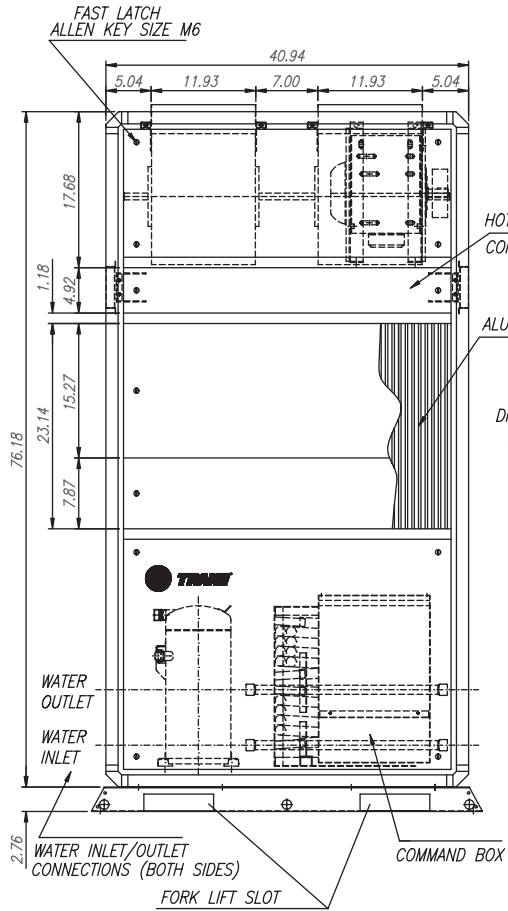

vertical discharge

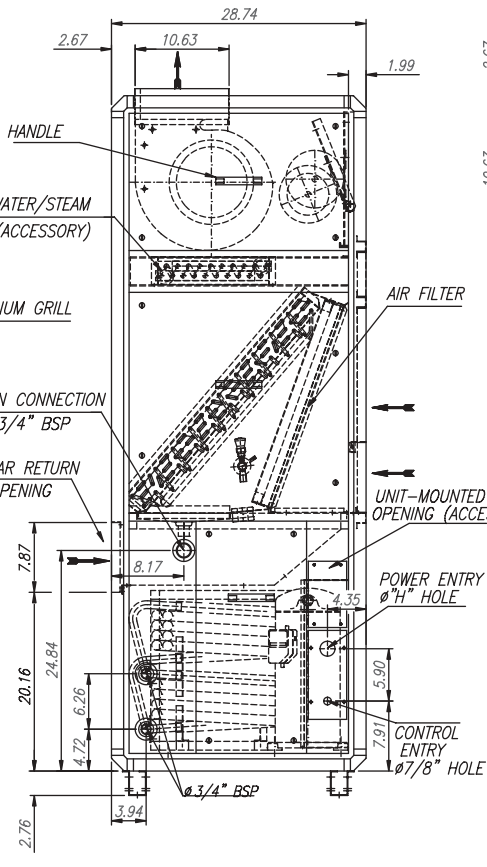

SCWH/SIWH

horizontal discharge  
(field converted)

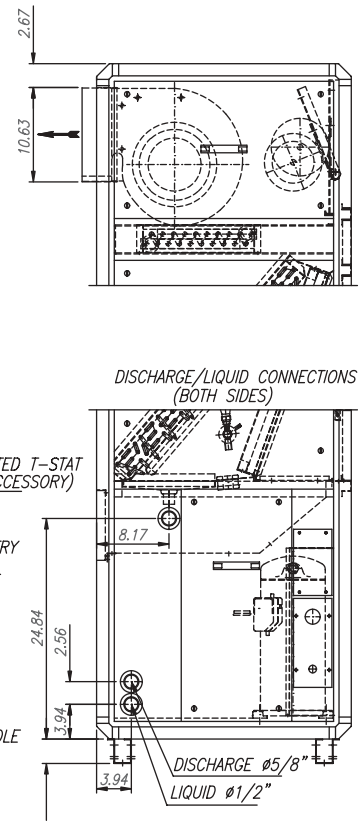

SCRH/SIRH

### SCWH/SIWH/SCRH/SIRH weight, lbs.

unit size	shipping weight	operating weight
7.5	702	657

# Installation

# dimensions & weights

## 10, 12, & 15-tons with top-mounted fan configuration SCWH/SIWH/SCRH/SIRH

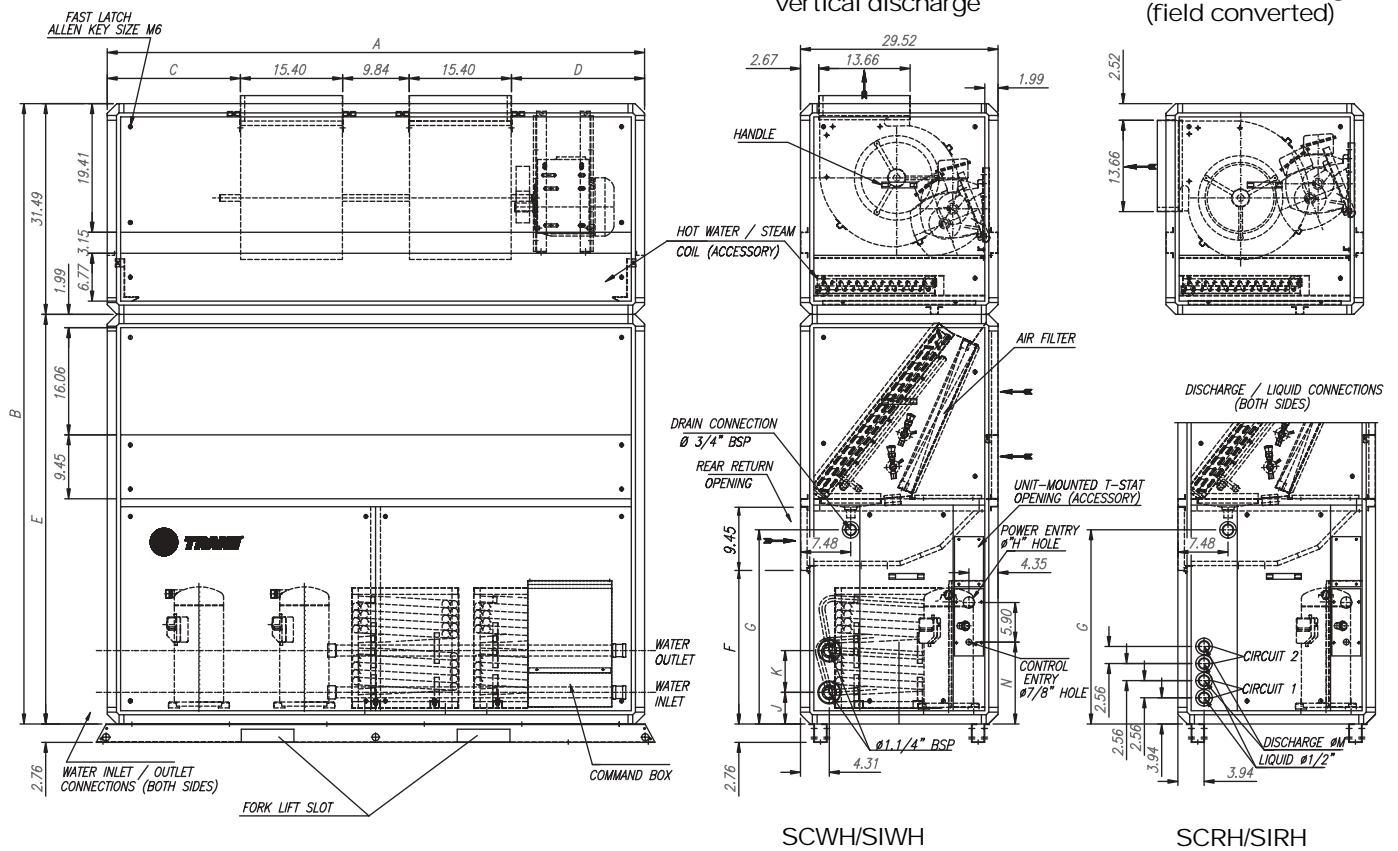

SCWH/SIWH/SCRH/SIRH dimensions & weight, in-lbs.

unit tons	A	B	C	D	E	F	G	J	K	M	N	shipping weight	operating weight
10	66.75	88.78	7.04	18.07	57.28	19.01	25.0	5.23	7.48	5/8	8.30	984	917
12	65.75	92.71	7.04	18.07	61.22	22.95	29.01	5.23	7.48	5/8	12.24	977	907
15	80.31	92.71	19.83	19.83	61.22	22.95	29.01	4.76	5.12	3/4	12.24	1098	1021



# Installation dimensions & weights

## 10, 12, & 15-tons with side-mounted fan configuration, field converted SCWH/SIWH/SCRH/SIRH

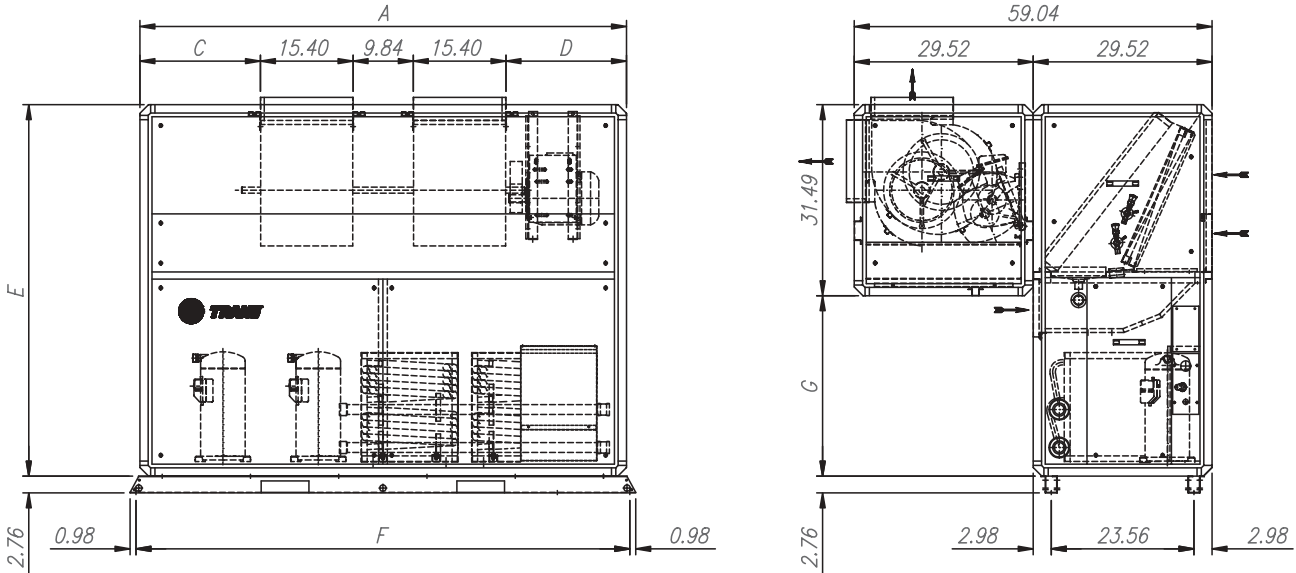

- Notes:
1. Base rail must be attached to the floor before converting unit to side-mounted fan configuration.
  2. Coil or electric heater cannot be assembled inside the cabinet with the side-mounted fan configuration.

**SCWH/SIWH/SCRH/SIRH Dimensions, in.**

unit tons	A	C	D	E	F	G
10	65.75	7.04	18.07	57.28	66.93	25.79
12	65.75	7.04	18.07	61.22	66.93	29.73
15	80.31	19.83	19.83	61.22	81.49	29.73

# Installation

## dimensions & weights

### Plenum

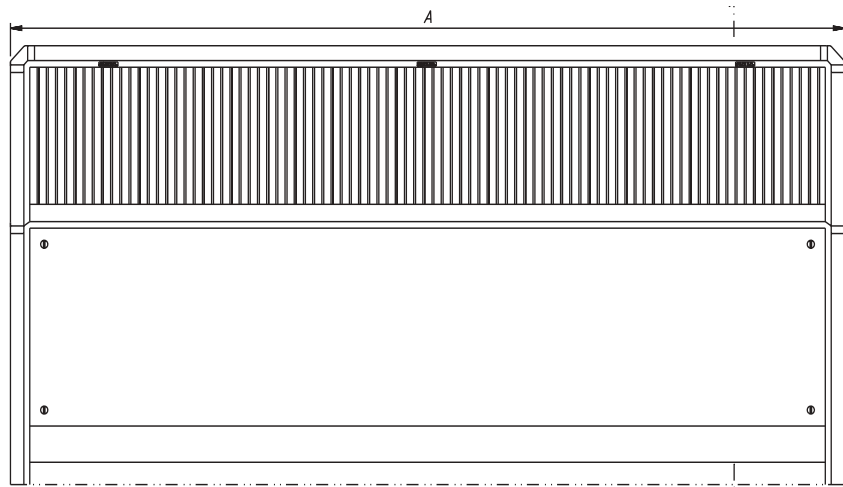
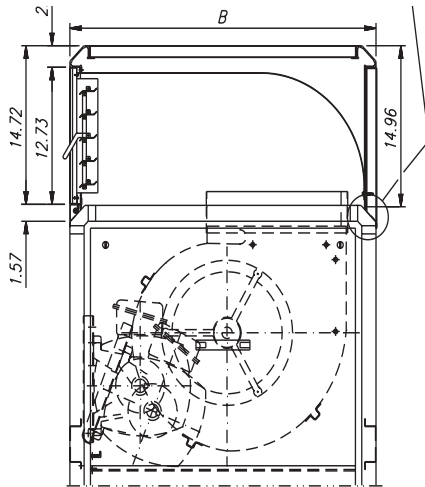

*Plenum dimensions & weight, in-lbs.*

unit size	A	B	weight
3-ton	31.89	22.24	44
5-ton	36.41	24.01	54
7.5-ton	40.94	28.74	73
10 & 12-ton	65.75	29.52	120
15-ton	80.31	29.52	146

### Hot water coil 3 & 5-ton units

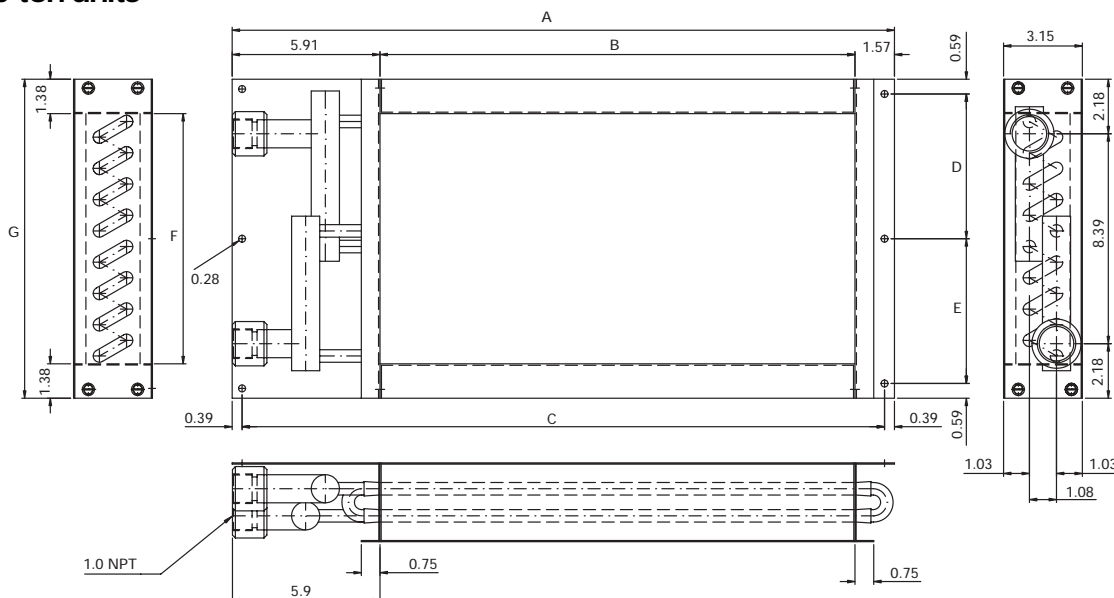

*SCWH/SCRH/SCRH/SIRH Hot water coil dimensions & weights, 3 & 5-ton units, in-lbs.*

size	A	B	C	D	E	F	G	weight
3-ton	26.46	18.98	25.67	5.79	5.79	10.00	12.76	13
5-ton	30.98	23.50	30.20	7.040	7.040	12.50	15.26	18

# Installation

## dimensions & weights

### Hot water coil 7.5-ton units

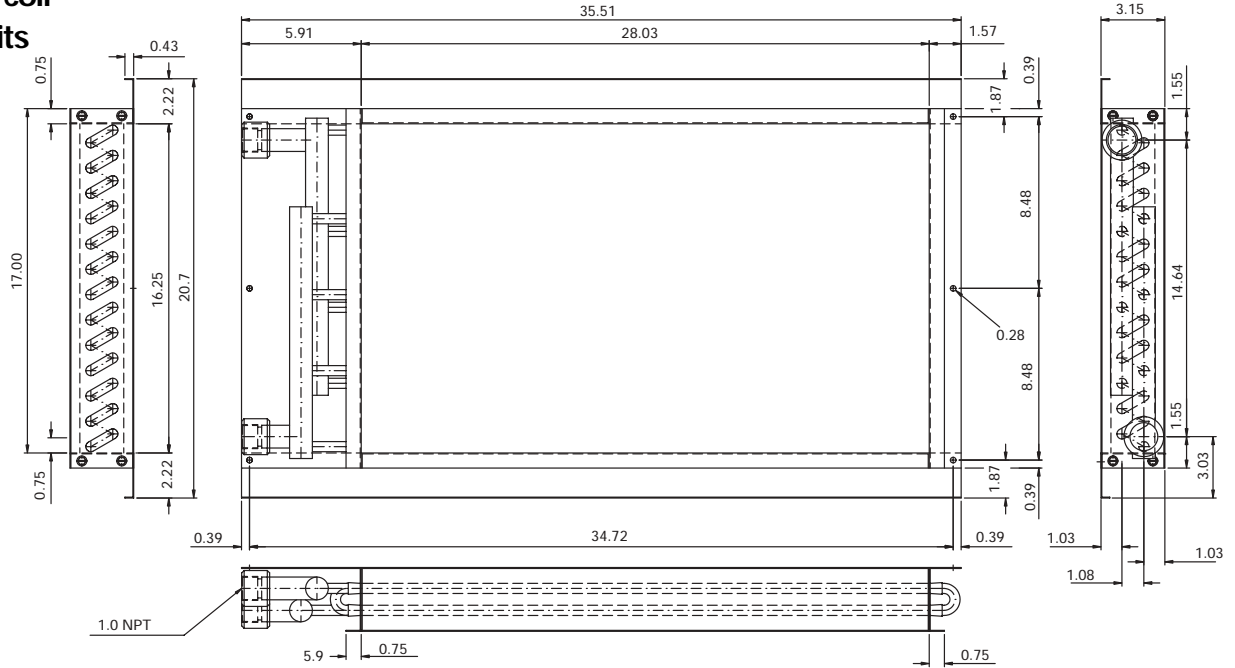

*SCWH/SCRH/SCRH/SIRH Hot water coil dimensions & weights, in-lbs.*

size	A	B	C	D	weight
7.5-ton	-	-	-	-	24
10-ton	58.72	50.98	6.95	59.51	49
12-ton	58.72	50.98	6.95	59.51	49
15-ton	73.29	63.98	8.52	74.07	55

### Hot water coil 10 thru 15-ton units

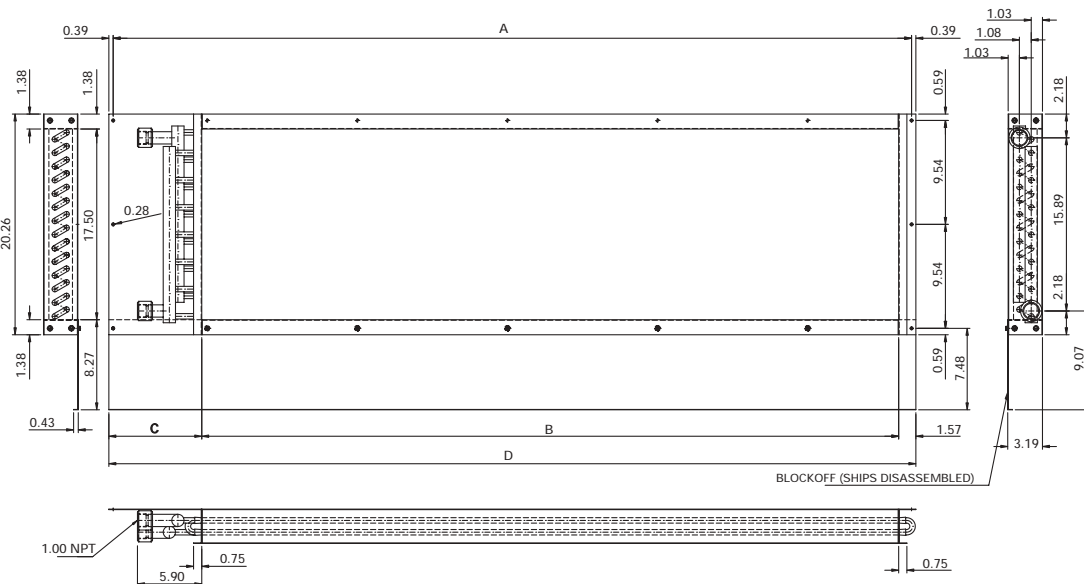



# Installation

## Duct Connections

Install all air ducts according to the National Fire Protection Association standards for the "Installation of Air Conditioning and Ventilation Systems other than Residence Type (NFPA 90A) and Residence Type Warm Air Heating and Air Conditioning Systems (NFPA 90B).

Make duct connections to the unit with a flexible material such as heavy canvas. If a fire hazard exists, Trane recommends using Flexweave 1000, type FW30 or equivalent canvas. Use **three inches** for the return duct and **three inches** for the discharge duct. Keep the material loose to absorb fan vibration.

Run the ductwork straight from the opening for a minimum of three fan diameters. Do not make abrupt turns or transitions near the unit due to increased noise and excessive static losses. Use elbows with splitters or turning vanes to minimize static losses.

Poorly constructed turning vanes may cause airflow generated noise. Check total external static pressures against fan characteristics to be sure the required airflow is available throughout the ductwork.

---

### WARNING

#### *Hazardous Voltage!*

Disconnect all electric power, including remote disconnects before servicing. Follow proper lockout/tagout procedures to ensure power cannot be inadvertently energized. Failure to disconnect power before servicing could result in death or serious injury.

---

## Water Piping

### Condenser Connections

**Note: To prevent water damage, install piping drain and vent plugs.**

Condenser water piping knockouts are in the lower left end panel. If necessary, remove insulation to gain access. All field installed piping must conform to applicable local, state, and federal codes. To complete condenser water connections follow the procedure below.

1. Remove back panel to access the water connection fittings.
2. Attach the water supply line to the inlet connection, and the return line to the outlet connection. The water connection fittings are copper, so exercise extreme care when connecting steel piping to copper fittings.
3. Ensure that water piping is aligned to the unit connection fittings. Failure to align piping could cause stripped threads, leakage, and possible unit failure.
4. Connection to the unit water piping requires a backing wrench to prevent distortion of connecting tubing. Apply backing wrench to water connection points on unit.

### Condensate Drain Connections

Install a water regulating valve in the water supply line to maintain head pressure when operating with city water of varying temperature.

These units require a minimum water pressure of 15 psig and will operate at a maximum of 400 psig.

Provide safeguards against cold weather

drain line freeze.

### Cooling Tower Piping

Cooling tower control affects the unit cycle rates. Condenser water temperature swings from 10-15°F may cause excessive compressor, water valve, and unit cycling. Be sure to set the tower controls to minimize compressor/unit cycling.

The cooling tower system requires a separate drain in the water supply line for service and repair.

### Water Temperature Requirements

Install a water regulating valve in the water supply line to maintain head pressure when operating with water of varying temperature. The valve modulates condenser water flow to control condensing pressure. The valve opens or closes in response to compressor discharge pressure as sensed by its capillary line connection in the liquid line shradder valve. When the valve is properly installed, water flow automatically decreases as discharge pressure falls and increases as discharge pressure rises. Field installation of the water regulating valve assembly requires one valve for each refrigeration circuit.

# Installation

## mechanical requirements

### Refrigerant Piping (Air-Cooled Units Only)

Reference industry recommendations for air-cooled unit refrigerant piping. If suspending piping from the building, use isolation hangers to prevent vibration transmission.

Air-cooled units ship with a holding charge of nitrogen. Before installing unit piping, momentarily depress either the suction or discharge line access valve to verify that the holding charge has not been lost. If nitrogen does not escape when depressing the access valve, leak-test the entire refrigerant system to determine the source of loss.

The charge is contained by a continuous loop of both hot gas and liquid lines. You must cut the loop for connection to discharge and liquid lines. See Figure I-MR-1.

#### Brazing Procedures

Proper brazing techniques are essential when installing refrigerant piping. Keep the following factors in mind when making sweat connections.

1. When heating copper in the presence of air, copper oxide forms. To prevent copper oxide from forming inside the tubing during brazing, sweep an inert gas, such as dry nitrogen, through the tubing. Nitrogen displaces air in the tubing and prevents oxidation of interior surfaces. A nitrogen flow of one to three cubic feet per minute is sufficient to displace the air. Use a pressure regulating valve or flow meter to control the flow.

2. Ensure tubing surfaces that require brazing are clean and the ends of the tubes are carefully reamed to remove any burrs.
3. Make sure the inner and outer tubes of the joint are symmetrical and have a close clearance, providing an easy slip fit. If the joint is too loose, the tensile strength of the connection will be significantly reduced. Make the overlap distance equal to the inner tube diameter.
4. Wrap the body of each refrigerant line component with a wet cloth to keep it cool during brazing. Excessive heat can damage the components.
5. If using flux, apply it sparingly to the joint. Excess flux will contaminate the refrigerant system.
6. Apply heat evenly over the length and circumference of the joint, making sure the entire joint becomes hot enough to melt the brazing material.
7. Begin brazing when the joint is hot enough to melt the brazing rod. The hot copper tubing, not the flame, should melt the rod.
8. Continue to apply heat around the joint circumference until the brazing material is drawn into the joint by capillary action, making a mechanically sound and gas-tight connection.
9. Visually inspect the connection after brazing to locate any pin holes or crevices in the joint. Use a mirror to inspect connections that are difficult to see.

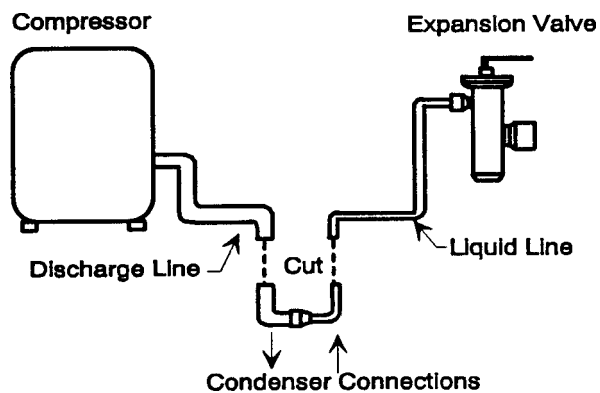

Figure I-MR-1. Air-cooled unit refrigerant piping

## Installation

### Electrical Requirements

Follow these guidelines, referring to unit wiring diagrams and supply power dimensional information to ensure correct electrical requirements at the installation site. Reference supply power wiring locations on unit submittals or in the "Dimensions and Weights" section. Specific unit wiring diagrams are provided on each unit. Use these diagrams for connections or trouble analysis.

#### Unit Wiring Diagrams

Specific unit wiring diagrams are provided on the inside of the control panel door. Use these diagrams for connections or trouble analysis.

#### Supply Power Wiring

It is the installer's responsibility to provide power supply wiring to the unit terminal block or the non-fused disconnect switch option. Wiring should conform to NEC and all applicable code requirements.

1. Verify the power supply available is compatible with the unit nameplate ratings. The supply power must be within 10% of the rated voltage listed on the unit nameplate.
2. Reference the electrical data in Table I-ER-1. Protect the electrical service from over current and short circuit conditions in accordance with NEC requirements. Size protection devices according to the electrical data on the unit nameplate.
3. If using a field-supplied disconnect, install it at or near the unit in accordance with NEC. Do not mount a field-supplied disconnect on the unit. Reference the electrical service entrance location on unit submittals.
4. Complete the unit power wiring connections onto either the main terminal block or the field-provided non-fused disconnect switch.
5. Provide proper unit grounding in accordance with local and national codes.

### Electrical Data Calculations

RLA = rated load amps  
 Compressor LRA = locked rotor amps  
 Fan motor LRA = locked rotor amps,  
 N.E.C. Table 430 - 151  
 FLA = Full load amps, N.E.C.  
 Table 430 - 150

Voltage utilization range is  $\pm 10\%$

Minimum circuit ampacity (MCA)  
 = 1.25 x largest motor amps (FLA or RLA) + the sum of the remaining motor amps.

Maximum fuse size (MFS) and maximum circuit breaker size (MCB) = 2.25 x largest motor amps (FLA or RLA) + the sum of the remaining motor amps.

Note: If the rating value determined does not equal a standard current rating of over current protective device, use the next lower standard rating for the marked maximum rating.

#### Voltage Range

Voltages must be within  $\pm 10\%$  the nameplate voltage. Ensure the unit voltage is balanced by measuring at the compressor terminals. Voltage imbalance on three phase systems can cause motor overheating and premature failure. Maximum allowable imbalance is 2.0%.

#### Voltage Imbalance

Read the voltage at the compressor terminals to determine if it is balanced. Voltage imbalance on three phase systems can cause motor overheating and premature failure. The maximum allowable imbalance is 2.0%. Voltage imbalance is defined as 100 times the sum of the deviation of the three voltages from the average (without regard to sign) divided by the average voltage. For example, if the three measured voltages are 221, 230, and 227, the average voltage would be:

$$\frac{(221 + 230 + 227)}{3} = 226 \text{ volts}$$

The percentage of voltage imbalance is then:

$$100 * \frac{(226-221)}{226} = 2.2\%$$

In this example, 2.2% imbalance is not acceptable. Whenever a voltage imbalance of more than 2.0% exists, check the voltage at the unit disconnect switch. If the imbalance at the unit disconnect switch does **not** exceed 2.0%, faulty unit wiring is causing the imbalance. Conduct a thorough inspection of the unit electrical wiring connections to locate the fault, and make any repairs necessary.

#### WARNING

*Live Electrical Components!*  
 During installation, testing, servicing, and troubleshooting this equipment, it may be necessary to work with live electrical components. Have a qualified licensed electrician or other individual who is properly trained in handling live electrical components perform these tasks. Failure to follow all electrical safety precautions when exposed to live electrical components could result in death or serious injury.

#### WARNING

*Hazardous Voltage!*  
 Disconnect all electric power, including remote disconnects before servicing. Follow proper lockout/tagout procedures to ensure power cannot be inadvertently energized. Failure to disconnect power before servicing could result in death or serious injury.

#### CAUTION

*Use Copper Conductors Only!*  
 Unit terminals are not designed to accept other type conductors. Failure to use copper conductors may result in equipment damage.



# Installation

# electrical requirements

Table I-ER-1. Model SCWH/SIWH/SCRH/SIRH electrical data

model	tons	voltage	compressor			evaporator standard motor					evaporator oversized motor				
			RLA	LRA	qty.	evap. fan motor		min. circuit ampacity	MFS / MCB	evap. fan motor			min. circuit ampacity	MFS / MCB	
hp	FLA	qty.	hp	FLA	qty.	hp	FLA			qty.					
SC*H0303....	3	208-230V/60Hz/3Ph	12.9	77.0	1	0.5	2.21	1	18.3	30	1	3.15	1	19.3	30
SC*H0304....		460V/60Hz/3Ph	5.7	35.0		1.00	8.1	15	1.42	8.5		15			
SC*H0305....		575V/60Hz/3Ph	4.8	31.0		0.80	6.8	15	1.14	7.1		15			
SC*H0503....	5	208-230V/60Hz/3Ph	22.9	155.0	1	1	5.00	1	33.6	50	2	5.81	1	34.4	50
SC*H0504....		460V/60Hz/3Ph	10.7	75.0			2.50		15.9	25		2.63		16.0	25
SC*H0505....		575V/60Hz/3Ph	8.5	54.0			1.50		12.1	20		2.10		12.7	20
SC*H0753....	7.5	208-230V/60Hz/3Ph	27.9	164.0	1	2	6.30	1	41.2	60	2	5.81	1	40.7	60
SC*H0754....		460V/60Hz/3Ph	13.6	100.0			3.10		20.1	30		2.63		19.6	30
SC*H0755....		575V/60Hz/3Ph	10.2	78.0			2.40		15.2	25		2.10		14.9	25
SC*H1003....	10	208-230V/60Hz/3Ph	22.9	155.0	2	2	6.30	1	57.8	80	5	13.70	1	65.2	80
SC*H1004....		460V/60Hz/3Ph	10.7	75.0			3.10		27.2	35		6.18		30.3	40
SC*H1005....		575V/60Hz/3Ph	8.5	54.0			2.40		21.5	30		4.94		24.1	30
SC*H1203....	12	208-230V/60Hz/3Ph	25.4	147.7	2	3	9.40	1	66.5	90	5	13.70	1	70.8	90
SC*H1204....		460V/60Hz/3Ph	11.8	75.0			4.60		31.2	40		6.18		32.7	45
SC*H1205....		575V/60Hz/3Ph	9.3	59.6			3.40		24.4	30		4.94		25.9	35
SC*H1503....	15	208-230V/60Hz/3Ph	27.9	164.0	2	3	9.40	1	72.2	100	5	13.70	1	76.5	100
SC*H1504....		460V/60Hz/3Ph	13.6	100.0			4.60		35.2	45		6.18		36.8	50
SC*H1505....		575V/60Hz/3Ph	10.9	78.0			3.40		27.9	35		4.94		29.5	35

Notes:

1. Voltage range:

Nominal voltage 208 - 230V - acceptable range: 187 - 253V

Nominal voltage 460V - acceptable range: 414 - 506V

Nominal voltage 575V - acceptable range: 518 - 633V

2. Ampacity is calculated per UL formula, ampacity = (1.25 x compressor RLA + sum of the second compressor RLA (if used) + evaporator motor FLA

3. Maximum fuse size is calculated per UL formula, MFS = (2.25 x compressor RLA) + sum of second compressor RLA (if used) + evaporator motor FLA

**WARNING**

*Hazardous Voltage!*

Disconnect all electric power, including remote disconnects before servicing. Follow proper lockout/tagout procedures to ensure power cannot be inadvertently energized. Failure to disconnect power before servicing could result in death or serious injury.

**CAUTION**

*Use Copper Conductors Only!*

Unit terminals are not designed to accept other type conductors. Failure to use copper conductors may result in equipment damage.

# Installation

## installation procedure

### Installation Checklist

Reference the checklist below to verify all steps required to successfully install a deluxe self-contained unit are complete. This checklist is intended to acquaint the installing personnel with what is required in the installation process. It does not replace the detailed instructions detailed in the applicable sections of this manual.

#### WARNING

##### *Hazardous voltage!*

Before servicing unit disconnect all electrical power including remote disconnects. Follow proper lockout/tagout procedures to ensure power cannot be inadvertently energized. Failure to disconnect power before servicing can cause death or serious injury.

#### General Unit Requirements

- Install and secure the ductwork to the unit.
- Check unit for shipping damage and material shortage. Refer to the Receiving Checklist.

#### Electrical Requirements

- Verify that the electrical power supply characteristics comply with the unit nameplate specifications.
- Inspect all control components; tighten any loose connections.
- Connect properly sized and protected power supply wiring to a field supplied/installed disconnect and unit power terminal block, or to the optional unit mounted disconnect switch.
- Properly ground the unit.

#### Field Installed Control Wiring (Optional)

- Complete the field wiring connections.

**Note:** All field installed wiring must comply with NEC and applicable local codes.

#### Fan Discharge Conversion

Complete the steps below to convert the fan discharge from vertical to horizontal.

1. Remove all mid and top fan section panels.
2. Loosen the brackets inside the unit that clamp the mid and fan sections together.
3. Remove the control box cover and disconnect the motor power wires. Feed wires up through the unit and secure out of the way until rotation is complete.
4. Rotate the fan section to desired position.
5. Re-route the motor power wires back to the control box. Ensure all wiring is free and not routed over any sharp edges.

6. Reconnect the motor power wires per the unit wiring diagram.
7. Bolt and/or clamp all brackets back into place.
8. Replace control box cover and all exterior panels.
9. Verify the fan rotation and motor amp draw.

#### Plenum Installation

1. Uncrate the plenum and accessory bag.
2. Rotate the evaporator blower to the vertical discharge configuration.
3. Apply the soft gasket provided around the aluminum frame on top of the unit as shown in Figure I-IP-1.
4. Using a screwdriver, tighten the self-drilling screws as shown in Figure I-IP-1. Be sure to tighten all screws on the rear, right, and left sides through the pilot holes on the plenum panels.
5. When installation is complete, adjust the motor pulley and the discharge grille for proper airflow.

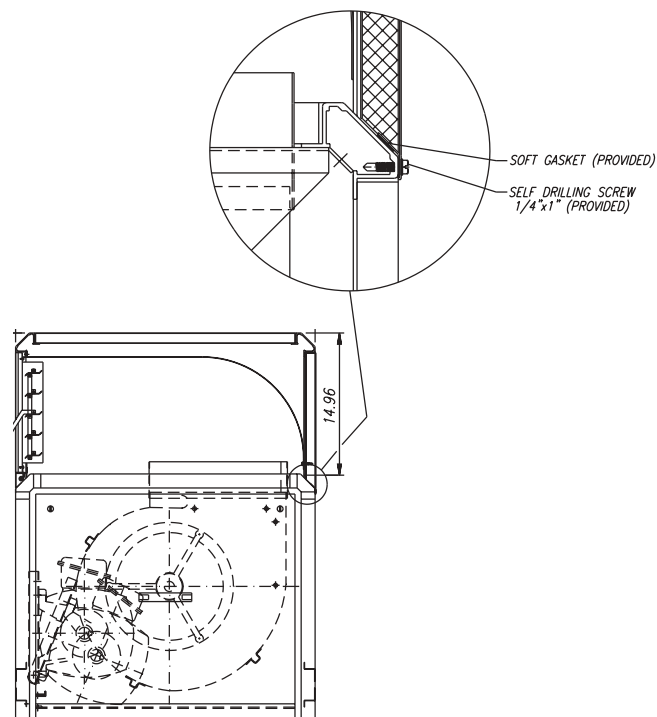

Figure I-IP-1. Plenum installation

# Installation

# pre-startup requirements

## Pre-Startup Checklist

Complete this checklist after installing the unit to verify all recommended installation procedures are complete before unit startup. This does not replace the detailed instructions in the appropriate sections of this manual. Always read the entire section carefully to become familiar with the procedures.

---

### WARNING

*Hazardous Voltage!*  
Disconnect all electrical power, including remote disconnects before servicing. Follow proper lockout/tagout procedures to ensure power cannot be inadvertently energized. Failure to disconnect power before servicing could result in death or serious injury.

---

### Receiving

- Inspect unit and components for shipping damage. File damage claims immediately with the delivering carrier.**
- Check nameplate unit data so that it matches the sales order requirements.
- Check unit for missing material. Look for ship-with accessories that are packaged separately and placed inside the access panel, fan section, or compressor section. See the “Receiving and Handling” section.

### Unit Location

- Ensure the unit location is adequate for unit dimensions, ductwork, piping, and electrical connections.
- Ensure access and maintenance clearances around the unit are adequate. See the “Service Access” section.

### Unit Mounting

- Remove shipping brackets on the compressor assembly and supply fan.

### Component Overview

- Verify the fan and motor sheaves are aligned.
- Check the belt tension for proper adjustment.
- Ensure the fan rotates freely.
- Tighten locking screws, bearing set screws and sheaves.
- Ensure bearing locking collars do not wobble when rotated.
- Ensure all air filters are properly installed with consideration of size and air flow.
- Manually rotate the evaporator fan to ensure free movement. Verify that all of the fan mounting hardware is tight.

### Ductwork

- Verify that all ductwork conforms to NFPA 90A or 90B and all applicable local codes.

# Installation

# startup

---

## Unit Startup Procedures

1. Check all electrical connections for tightness.
2. Be sure all unit accessories are properly set and installed.
3. Model SCWH/SIWH: Verify condenser water piping is properly connected, supply, and return.
4. Model SCRH/SIRH: Verify refrigerant piping is properly connected, hot gas, and liquid.
5. Inspect all ductwork and duct connections.
6. Check for proper belt tension.
7. Check fan drive sheaves, pulleys, and bearings.

### Unit Startup Checklist

1. Turn the thermostat to the OFF position.
2. Engage power supply by closing power disconnect.
3. Switch thermostat to fan position and adjust temperature setting below room temperature. Evaporator fan should start.

4. Check evaporator section for proper operation.
5. Switch thermostat to cool position and adjust temperature setting to below room temperature. The evaporator fan and compressor(s) should start.

---

***Note: These units are equipped with high efficiency scroll compressors. Check for proper scroll rotation prior to operating unit.***

---

6. Check the evaporator fan for proper rotation. If fan rotation is incorrect, switch thermostat to Off position and disconnect power. Reverse two phase leads at disconnect and return back to Step 1 of startup.
7. Allow unit to run until all system temperatures and pressures stabilize.
8. Check systems for proper operation and performance. Observe unit in operation and check for unusual noise, vibration, belt, and fan clearances.



# Operation

# sequence of operation

---

## Sequence of Operation

The thermostat controls the unit operation. It has both manual and automatic switches so the thermostat maintains desired comfort levels.

The fan switch allows manual selection of the fan speed using the On or Auto setting. With the switch set in the On position, the evaporator fan runs continuously, independent from the thermostat temperature setting. The Auto position cycles the evaporator fan on and off with the demand for heating or cooling.

The system switch may have two or more positions. For example, using a cooling only thermostat, the system switch can be set in the Off or the Cool position. The Off position disconnects power from the thermostat contacts that control the condensing unit. This prevents

the condensing unit from running, regardless of the thermostat temperature setting. The evaporator fan may circulate air if the fan switch is in the On position. With the switch in the Cool position, the condensing unit and evaporator will operate on a signal from the thermostat calling for cooling.

With the fan switch set to Auto and the system switch set to Cool, the following sequence takes place. On a rise in room temperature, the thermostat contacts close to provide power to the evaporator fan contactor, the condensing unit fan contactor, and the condensing unit compressor contactors. As the room temperature reaches setpoint, the thermostat contacts open to de-energize all contactors, and the system cycles off. This system will remain off until additional cooling is required and the cycle repeats.





# Maintenance

# general information

**Table M-GI-1. Midrange maintenance general data**

	SCWH030	SCWH050	SCWH075	SCWH100	SCWH120	SCWH150
dimensions, in-lbs.						
height	66.93	78.74	78.94	91.54	95.47	95.47
length	31.89	36.41	40.94	65.75	65.75	80.31
depth	22.24	24.01	28.74	29.52	29.52	29.52
weight (shipping / net)	494 / 459	592 / 555	702 / 657	1094 / 1027	1133 / 1063	1249 / 1172
cooling performance						
net cooling capacity, btu/h	36000	65290	87570	116986	138204	167303
EER	12.13	12.28	11.6	11.5	11.1	11.3
nominal air flow, cfm	1200	2000	3000	4000	4800	6000
system power, kW	3.0	5.3	7.6	10.2	12.5	14.8
Copeland scroll compressor						
quantity	1	1	1	2	2	2
model	ZP32	ZP57	ZP83	ZP57	ZP67	ZP83
indoor coil, 3/8" tube size						
face area, sq. ft.	3.19	4.98	7.13	12.12	12.12	14.56
rows / fpf	4 / 144	4 / 144	3 / 168	2 / 168	2 / 168	3 / 168
water condenser, tube & tube						
water connection, in.	3/4 NPT	3/4 NPT	3/4 NPT	1 1/4 NPT	1 1/4 NPT	1 1/4 NPT
indoor fan, belt-driven						
quantity	1	1	2	2	2	2
diameter x width	9 x 9	10 x 10	9 x 9	12 x 12	12 x 12	12 x 12
motor	1 / 0.5	1 / 1.0	1 / 2.0	1 / 2.0	1 / 3.0	1 / 3.0
motor frame size	56	56	56	56	56	56
air filter, 1" throwaway						
size / (quantity), in.	14 x 25 (1)	14 x 20 (1) + 20 x 20 (1)	18 x 24 (2)	12 x 24 (1) + 24 x 24 (2)		18 x 24 (3) + 24 x 24 (1)
refrigerant, R-410A, TXV control						
refrigerant charge (Ckt 1 / 2), lbs.	3.8	5.4	7.8	5.1 / 5.2	6.5/6.3	7.2/7.2
hot water coil, 2-row, 108 fpf, 1/2" tubes						
face area, sq. ft.	1.42	2.08	3.27	6.2	6.2	7.78

**Notes:**

1. Net cooling capacity is rated at 95°F ambient, 80°F entering dry bulb and 67°F entering wet bulb @ SCFM air condition.
2. EER is rated at ARI condition.

# Maintenance

## maintenance procedures

### Maintenance Procedures

This section describes specific maintenance procedures that must be performed as a part of the normal maintenance program. Always disconnect electrical power to the unit before performing these procedures and heed all warnings and cautions.

#### **WARNING**

##### *Live Electrical Components!*

During installation, testing, servicing, and troubleshooting this equipment, it may be necessary to work with live electrical components. Have a qualified licensed electrician or other individual who is properly trained in handling live electrical components perform these tasks. Failure to follow all electrical components could result in death or serious injury.

#### **WARNING**

##### *Hazardous Voltage!*

Disconnect all electrical power including remote disconnects before servicing unit. Follow proper lockout/tagout procedures to ensure power cannot be inadvertently energized. Failure to disconnect power before servicing can result in death or serious injury.

#### Periodic Maintenance Checklist

- Inspect coil surface for cleanliness. Clean as required, referring to the "Coil Cleaning" section.

#### Annual Maintenance Checklist

- Perform all monthly maintenance inspections.
- Perform seasonal startup checks.
- Leak test refrigerant circuits. Inspect contacts of fan motor contactors and relays. Replace all worn contacts.
- Clean and repaint any corroded surface.

---

**Note: the following coil cleaning procedures apply only to the outdoor condensers. Do not use these procedures for the reheat or evaporator coils.**

---

#### Cleaning the Condenser Coils

Clean the coil at least once each year or more frequently if located in a dirty environment, to help maintain proper unit operating efficiency. High discharge pressures are a good indication that the coil needs cleaning. Follow the detergent manufacturer instructions as closely as possible to avoid potential coil damage.

#### **WARNING**

##### *Hazardous Chemicals!*

Coil cleaning agents can be either acidic or highly alkaline. Handle chemical carefully. Proper handling should include goggles or face shield, chemical resistant gloves, boots, apron, or protective suit as required. For personal safety, refer to the cleaning agent manufacturer's materials safety data sheet and follow all recommended safe handling practices. Failure to follow all safety instructions could result in death or serious injury.

To clean the refrigerant coil, use a soft brush and sprayer, such as a garden pump up or high pressure type. In addition, use a quality detergent; like "SPREX AC", "OAKITE 161" or "OAKITE 166" and "COILOX."

---

**Note: If detergent is strongly alkaline (i.e. has a pH value greater than 8.5) after mixing, you must add an aluminum corrosion inhibitor.**

---

#### Coil Cleaning Procedure

1. Disconnect power to the unit.
2. Remove panels from the unit to gain access to the coil.
3. Use a soft brush to remove loose dirt and debris from both sides of the coil.
4. Straighten coil fins with fin comb as required.
5. Mix the detergent with water according to the manufacturers instructions.

Observe all recommendations of the cleanser manufacturer. The coil cleanser manufacturer's recommendations, warnings and cautions will at all times take precedence to these instructions.

1. Place solution in the sprayer. Be sure to follow these guidelines if using a high-pressure sprayer:
  - a) Keep minimum nozzle spray angle 15°.
  - b) Spray solution at a 90° angle to the coil face.
  - c) Keep sprayer nozzle at least six inches from the coil.
  - d) Sprayer pressure must not exceed 600 psi.
2. Spray leaving air side of the coil first then spray the entering air side of the coil. Allow the detergent and water solution to stand on the coil for five minutes.
3. Rinse both sides of the coil with cool, clean water.
4. Inspect the coil. If it still appears dirty, repeat the cleaning procedure.
5. Reinstall all unit components and panels, and restore electrical power and gas supply to the unit.

#### **CAUTION**

##### *Freezing Temperatures!*

Do not allow liquid refrigerant to come into contact with the skin. If it does, treat the injury similar to frostbite. Slowly warm the affected area with lukewarm water and seek immediate medical attention. Direct contact with liquid refrigerant may cause minor or moderate injury.

# Maintenance

## Refrigerant System

### Special Note on Refrigerant Emissions

Follow the Trane recommended procedures on operation, maintenance, and service to ensure refrigerant conservation and emission reduction. Also, pay specific attention to the following:

- Whenever removing refrigerant from equipment, recover for reuse, recycle, reprocess (reclaim), or properly destroy it.
- Always determine possible refrigerant recycling or reclaiming requirements before beginning recovery. Questions about recovered refrigerants and acceptable refrigerant quality standards are addressed in ARI Standard 700.
- Use approved containment vessels and safety standards. Comply with all applicable transportation standards when shipping refrigerant containers.
- To minimize emissions while recovering refrigerant, use recycling equipment. Always attempt to use methods that pull the lowest possible system vacuum while recovering and condensing refrigerant into containment.
- When leak checking with trace refrigerant and nitrogen, use HCFC22 (R22) rather than CFC12 (R12) or any other fully halogenated refrigerants. Be aware of any new leak test methods that eliminate refrigerant as a trace gas.
- When cleaning system components or parts, do not use CFC11 (R11) or CFC113 (R113). Refrigeration system clean up methods using filters and dryers are recommended. Do not use solvents that have ozone depletion factors. Properly dispose of used materials.
- Take extra care to properly maintain all service equipment directly supporting refrigerant service work such as gauges, hoses, vacuum pumps, and recycling equipment.
- Stay aware of unit enhancements, conversion refrigerants, compatible parts, and manufacturer's recommendations that reduce refrigerant emissions and increase equipment operating efficiencies. Follow specific manufacturer's guidelines for conversion of existing systems.

- To assist in reducing power generation emissions, always attempt to improve equipment performance with improved maintenance and operations that will help conserve energy resources.

---

### WARNING

#### *Confined Space Hazards!*

Do not work in confined spaces where sufficient quantities of refrigerant or other hazardous, toxic, or flammable gas may be leaking. Refrigerant or other gases could displace available oxygen to breathe, causing possible asphyxiation or other serious health risks. Some gases may be flammable and or explosive. Evacuate the area immediately and contact the proper rescue or response authority. Failure to take appropriate precautions or to react properly to a potential hazard could result in death or serious injury.

---

### WARNING

#### *Hazard of Explosion!*

Use only dry nitrogen with a pressure regulator to pressurize the unit. Do not use acetylene, oxygen, compressed air, or mixtures containing them. Do not use mixtures of a hydrogen containing refrigerant and air above atmospheric pressure for pressure testing as they may become flammable and could result in an explosion. Refrigerant, when used as a trace gas should only be mixed with dry nitrogen for pressurizing units. Failure to follow these recommendations could result in death, serious injury, equipment, or property-only damage.

---

### WARNING

#### *Leak Testing!*

Do not exceed 200 psig when leak testing system. Failure to follow these instructions could result in an explosion causing death or serious injury.

In the event of required system repair, leak test the liquid line, evaporator coil, and suction line at pressures dictated by local codes, and using the following guidelines.

1. Charge enough refrigerant and dry nitrogen into the system to raise the pressure to 100 psig.
2. Use a halogen leak detector, halide torch, or soap bubbles to check for leaks. Check interconnecting piping joints, the evaporator coil connections, and all accessory connections.
3. If a leak is detected, release the test pressure, break the connections and reassemble it as a new joint, using proper brazing techniques.
4. If no leak is detected, use nitrogen to increase the test pressure to 150 psig and repeat the leak test. Also, use soap bubbles to check for leaks when nitrogen is added.
5. Retest the system to make sure new connections are solid.
6. If a leak is suspected after the system has been fully charged with refrigerant, use a halogen leak detector, halide torch, or soap bubbles to check for leaks.

### Refrigerant Evacuation

For field evacuation, use a rotary style vacuum pump capable of pulling a vacuum of 100 microns or less.

When connecting the vacuum pump to a refrigeration system, it is important to manifold the pump to both the high and low side of the system. Follow the pump manufacturer's directions.

---

### WARNING

#### *Use of Pressure Regulator – Valves – Gauges!*

Always use pressure regulators, valves, and gauges to control drum and line pressures when pressure testing equipment. Failure to follow these instructions could result in an explosion causing death, serious injury, or equipment damage.



# Maintenance

# maintenance procedures

**CAUTION**

*Motor Winding Damage!*

Do not use a megohm meter or apply greater than 50 VDC to a compressor motor winding while it is under a deep vacuum. Voltage sparkover may cause damage to the motor windings.



**WARNING**

*Hazardous Pressures!*

If a heat source is required to raise the tank pressure during removal of refrigerant from cylinders, use only warm water or heat blankets to raise the tank temperature. Do not exceed a temperature of 150°F. Do not, under any circumstances, apply direct flame to any portion of the cylinder. Failure to follow these safety precautions could result in a violent explosion, which could result in death or serious injury.

**Charging the Refrigerant System**

To completely charge the system, charge gaseous refrigerant into the suction line schrader valve with the unit running. However, make sure that some refrigerant is present in each circuit before starting the compressors.

**CAUTION**

**Compressor Damage!**

Do not allow liquid refrigerant to enter the suction line. Excessive liquid accumulation in the liquid lines may result in compressor damage.

**CAUTION**

**Compressor Damage!**

Never manually or automatically pump down below 7 psig. This will cause the compressor to operate in a vacuum and result in compressor damage.

**Table M-MP-1. Normal operation condition**

	water-cooled	air-cooled
high pressure	280 to 430 psig	320 to 570 psig
low pressure	100 to 160 psig	
superheat	4 to 9°C	
subcooling	5 to 10°C	

**Table M-MP-2. Controls adjustment**

control	disarming	rearming	unit (ton / voltage)
high pressure control (air-cooled & 12-ton water cooled)	624±17.5 psig	464±29 psig	
high pressure control (water-cooled except 12-ton)	450±10 psig	348±14.5 psig	
low pressure control	51±7 psig	94±7 psig	
motor windings thermostat, standard motor only	130±5C	90±5	3 / 204-230 & 575
	135±5C	92	5 / 208-230
	130±5C	92	5 / 575
	90±5C	57	7.5 - 10 / 208-230
	120±5C	69	7.5 - 10 / 575
	90±5C	57	12 - 15 / 208-230
	105±5C	61	12 - 15 / 575

# Maintenance

## periodic checklists

### Periodic Checklists

#### Monthly Checklist

The following checklist provides the recommended maintenance schedule to keep the unit running efficiently.

#### WARNING

**Hazardous Voltage!**  
Disconnect all electrical power including remote disconnects before servicing unit. Follow proper lockout/tagout procedures to ensure power cannot be inadvertently energized. Failure to disconnect power before servicing can result in death or serious injury.

1. Inspect unit air filters. Clean or replace if airflow is blocked or if filters are dirty.
2. Inspect coils for icing. Icing on the coils may indicate low airflow supply, restricted airflow from dirty fins.
3. Check the fan belt condition and tension. Adjust tension if belt is floppy or squeals continually.
4. Check and record operating pressures.

#### Semi-Annual Maintenance

1. Verify the fan motor is properly aligned and bolted tight to the motor frame.
2. Lubricate fan bearings.
3. With power disconnected, manually rotate the fan wheel to check for obstructions in the housing or

- interference with fan blades. Remove obstructions and debris. Center the fan wheel if necessary.
4. Check the fan assembly sheave alignment. Tighten set screws to their proper torques.

**Note: Perform this procedure monthly if the unit is in a coastal or corrosive environment.**

#### Annual Maintenance

Check and tighten all set screws, bolts, locking collars and sheaves.

1. Inspect, clean, and tighten all electrical connections.
2. Visually inspect the entire unit casing for chips or corrosion. Remove rust or corrosion and repaint surfaces.
3. Visually check for leaks in refrigerant piping.
4. Inspect fan, motor, and control contacts. Replace badly worn or eroded contacts.

5. Inspect the thermal expansion valve sensing bulbs for cleanliness, good contact with the suction line, and adequate insulation from ambient air.

#### WARNING

**Live Electrical Components!**  
During installation, testing, servicing, and troubleshooting this equipment, it may be necessary to work with live electrical components. Have a qualified licensed electrician or other individual who is properly trained in handling live electrical components perform these tasks. Failure to follow all electrical components could result in death or serious injury.

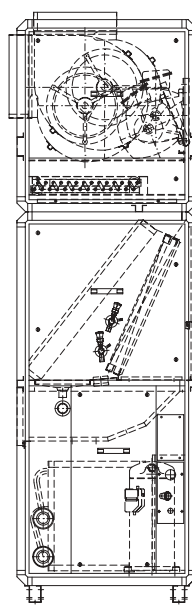

SCRH/SIRH/SCWH/SIWH 100-120-150

#### BELT TENSION ADJUSTMENT

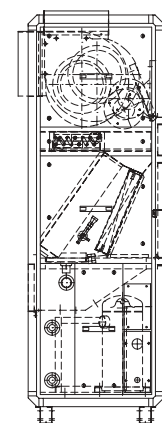

SCRH/SIRH/SCWH/SIWH 030-050-075

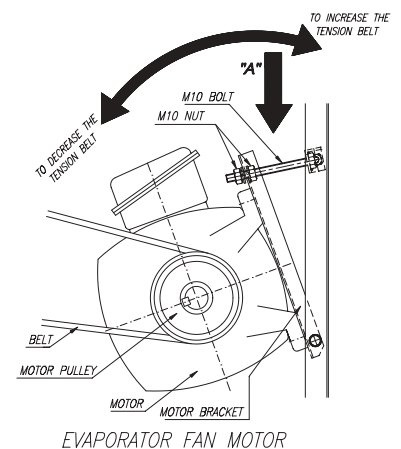

EVAPORATOR FAN MOTOR

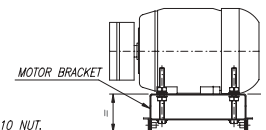

"A" VIEW  
MOTOR BRACKET  
ALIGNMENT (SEE NOTE 4)

- 1- USING A 17mm OPEN END WRENCH, LOOSEN THE BOTH, TOP AND BOTTOM, M10 NUT.
- 2- TO INCREASE THE BELT TENSION, MOVE DOWN THE MOTOR BRACKET.
- 3- TO DECREASE THE BELT TENSION, MOVE UP THE MOTOR BRACKET.
- 4- MAKE SURE THAT THE BOTH SIDE OF MOTOR BRACKET ARE ALIGNED WITH THE BASE. (SEE "A" VIEW)
- 5- "RETIGHTEN" THE M10 NUTS PROPERLY.
- 6- CHECK THE BELT TENSION; THE BELT CAN BE DEPRESSED APPROXIMATELY 1/2 INCH. WITH ONE FINGER BETWEEN THE FAN AND MOTOR PULLEY.

0511-2659



# Maintenance

# troubleshooting

## Troubleshooting

Use the following steps and procedures to help correct these common problems.

### Problem

The entire unit does not operate.

### Possible cause

1. Power interruption
2. Thermostat not operating
3. Electrical panel: a) 24-volt transformer defective; b) loose wire

### Remedy

1. Check for blown fuses or tripped circuit breakers. Replace or reset if necessary.
2. Setting may be too high; check unit and reset. Thermostat may be out of calibration or otherwise defective; replace.
3. Correct as required.

### Problem

Fan runs but compressor does not start.

### Possible cause

1. Low voltage
2. Remote thermostat
3. Compressor contactor open or burned
4. High pressure control cutting out unit
5. Refrigerant leak - no gas
6. Loose or defective wires.
7. Compressor shorted, open or burned
8. Defective compressor

### Remedy

1. Check power supply for voltage outside the acceptable voltage range.
2. Check the control unit for loose wires. Firm any loose connections.
3. Replace.
4. Check for loose wire connection, broken or burned contacts. If defective, replace.
5. Locate leak and repair. Recharge unit.
6. Tug on wires to see if they will separate from connections. Replace terminals if necessary.
7. Check for shorts, opens, and grounded. Remove and replace compressor.
8. Remove and replace.

### Problem

Unit held off by safety.

### Possible cause

1. Unit cutout on high pressure control, set at 385 psig
2. Refrigerant leak
3. Air restriction, dirty coils
4. Partial restriction in refrigerant system
5. High pressure control
6. TXV power element charge loss
7. Loose connection in electrical unit

### Remedy

1. Adjust tubes by bending slightly to firm position without touching other unit parts.
2. Level unit base. Fully support base.
3. Check and tighten loose screws.
4. Tighten screws on fan wheel shaft.
5. Adjust wheel position on motor shaft
6. Replace fan motor.
7. Replace fan bearing.

### Problem

Noisy operation.

### Possible cause

1. Copper tubing vibrating
2. Machine vibrating out of level

### Remedy

2. See if unit is low on refrigerant charge. Repair leak and recharge unit.
3. Verify if the air filter is dirty or has an airflow restriction, and correct problem.
4. Locate restriction by inspecting refrigerant lines for temperature changes. Remove restriction, evacuate, and recharge.
5. Replace, if defective.
6. Evacuate, replace element, recharge.
7. Trace and firm up connection.

# Maintenance troubleshooting

---

**Problem**

Insufficient cooling

**Possible cause**

1. Insufficient air flow due to: a) dirty evaporator; b) ice on evaporator coils (indicates airflow restriction through evaporator); c) dirty filter; d) obstructed discharge air intake; e) fan motor not running; f) evaporator fan or fan wheel slipping on motor shaft
2. Heat gain or loss in room exceeds unit capacity
3. Defective compressor
4. Insufficient refrigerant charge indicated  
by: a) low wattage; b) condenser air outlet cold
5. Overcharge of refrigerant indicated by high wattage and sweating of the compressor return line
6. Thermostat not set for full cooling
7. Insufficient airflow through condenser  
due to: a) dirty condenser; b) loose belt; c) fan loose on shaft
8. Cutout on high pressure
9. Only one refrigerant circuit operational in 2-circuit units

**Remedy**

1. Correct as follows: a) clean; b) defrost (using fan operation only); c) clean or replace filter; d) remove obstruction; e) check electrical system; f) adjust fan position. Tighten set screw on fan wheel.
2. Refer to original load calculations. Recalculate heat gain or loss.
3. Replace, if necessary.
4. Check refrigerant charge pressure with gauges. If refrigerant is low, recharge system.
5. Reclaim excess refrigerant.
6. Refer to thermostat operating instructions.
7. Correct as follows: a) clean coil; b) verify drive is adjusted correctly; c) tighten fan on shaft.
8. See that air is flowing and that damper is set properly.
9. Reset high pressure cutout on inoperative circuit. Check contactor in inoperative circuit.

**Problem**

Unit short cycles

**Possible cause**

1. Remote thermostat
2. Loose connection in electrical unit
3. Thermostat contacts fluttering
4. Air flow to evaporator is restricted
5. Insufficient charge

**Remedy**

1. Repair or replace.
2. Trace and repair.
3. Repair or replace.
4. Flush or blow dirt out of coil.
5. Reclaim, evacuate, recharge per nameplate.

**Problem**

Compressor starts and runs, but fan does not run.

**Possible cause**

1. Faulty switch
2. Open fan motor coil circuit
3. Fan binding on shroud or venturi ring

**Remedy**

1. Replace.
2. Replace.
3. Adjust fan mounting.





# Maintenance

# typical wiring diagram

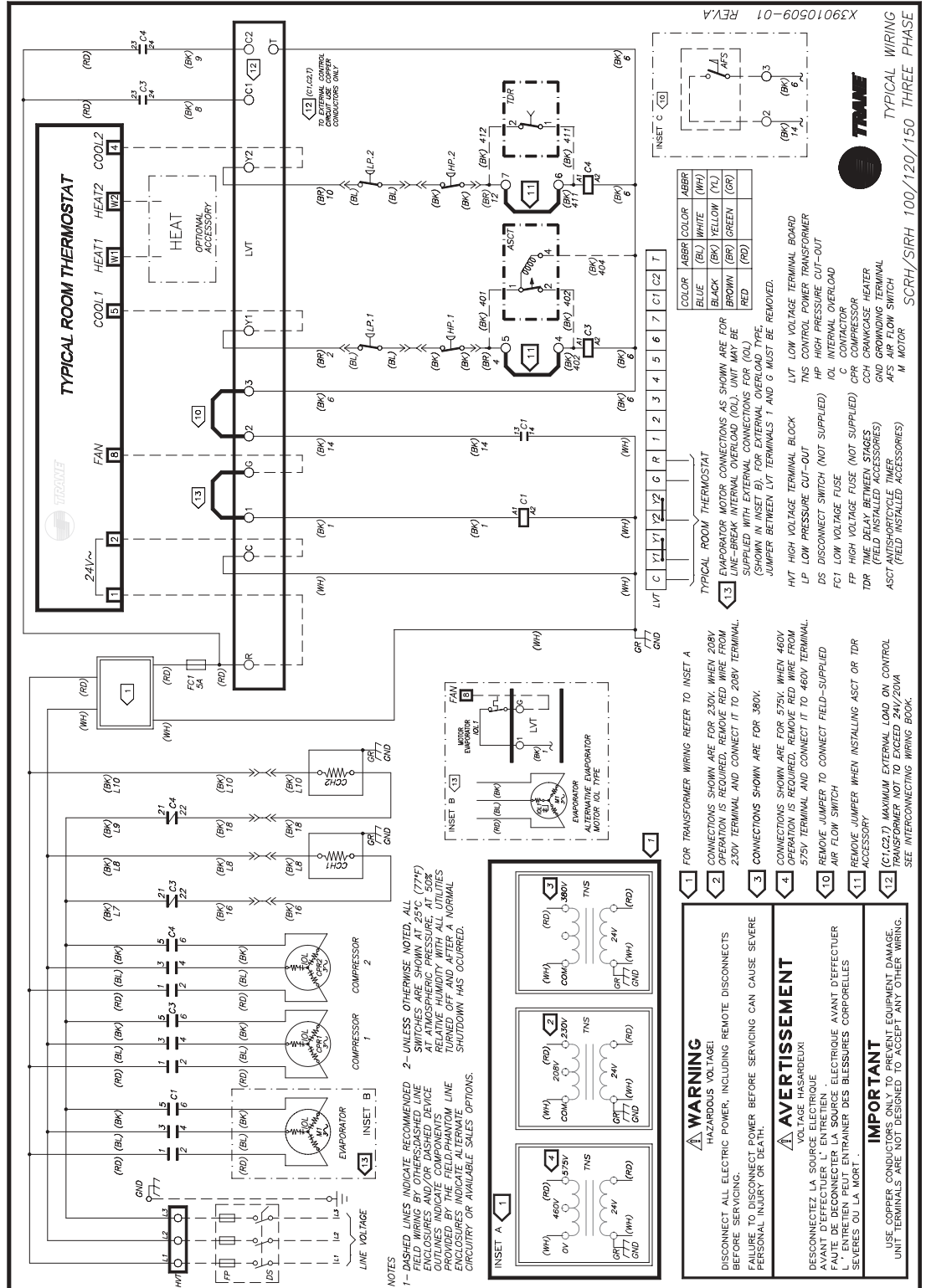







**TRANE®**

*a business of American Standard Inc.  
www.trane.com*

*For more information contact  
your local office or e-mail us at  
comfort@trane.com*

---

Literature Order Number

PKG-SVX14A-EN

---

File Number

PL-PKG-SVX14A-EN 0804

---

Supersedes

SWUB-IOM-2

---

Stocking Location

LaCrosse - Inland

---

Trane has a policy of continuous product improvement and reserves the right to change design and specifications without notice. Only qualified technicians should install and service equipment.