



## 38 SERIES STRAND SUBSTRATE SMOOTH FINISH OR CEDAR TEXTURE PREFINISHED LAP JOINT SIDING

### GENERAL

- At the time of manufacture, siding meets or exceeds the performance standards set forth in ICC-ES AC321 and has achieved code recognition under ESR-1301, CCMC 11826-L, APA recognition under PR-N124, and HUD recognition under HUD-MR-1318c. For copies of product approvals go online at <https://lpcorp.com/resources/product-literature/> or call LP Customer Support at 888-820-0325.
- Minimum 6 inch (152 mm) clearance must be maintained between siding and finish grade.
- Siding applied adjacent to porches, patios, walks, etc. must have a clearance of at least 1 inch (25 mm) above any surface.
- Minimum 1 inch (25 mm) clearance at intersection with roof line.
- Apply siding in a manner that prevents moisture intrusion and water buildup.
- All wood substrate that is exposed to the weather must be sealed in a manner that prevents moisture intrusion and water build up.
  - Seal ALL exposed cuts of siding and trim. Field spray applied coatings on cuts are not recommended.
  - Sealing can be accomplished by applying a coating or sealant according to the manufacturer's requirements.
- See Alternate Fastening Options for fastening lap siding to SIP or Wood Structural Panel Sheathing, Insulated Sheathing, ICF and Steel Frame assemblies.
- **DO NOT USE STAPLES.**
- SIDING MUST NOT BE IN DIRECT CONTACT WITH MASONRY, CONCRETE, BRICK, STONE, STUCCO OR MORTAR.
- Do not force siding into place.
- Climb cut the surface of the siding such that the rotation of the blade cuts downward on the prefinished surface.

### STORAGE AND HANDLING

- **Handle prefinished LP SmartSide ExpertFinish lap siding with extreme care during storage and application.**
- Store off the ground well supported, on a flat well-drained surface.
- Store products under a roof or separate waterproof covering.
- Additional support may be required to achieve a safe clearance from the ground.
- When the covering is removed, cut all unit banding.
- When unpackaging siding, cut the full length of the shrink-wrap to avoid dragging and scuffing of the sidings painted surface.

- Touch up any damage to finish that may occur during application per the Finishing, Care and Maintenance section in this document.

### STUD SPACING

- 38 Series Strand Substrate lap may be installed on studs spaced a maximum of 16 inches (406 mm) o.c.

### MOISTURE

- Moisture control and moisture vapor control are critical elements of proper housing design. Check your local building codes for application procedures for handling moisture and water vapor in your area.
- As with all wood products, do not apply engineered wood siding to a structure having excessive moisture conditions such as drying concrete, plaster or wet blown cellulose insulation. If such conditions exist, the building should be well ventilated to allow it to dry prior to the application of the siding.
- When using wet blown cellulose insulation, the insulation must not be in direct contact with the siding and it must be allowed to dry a minimum of 24 hours or longer if specified by the insulation manufacturer.
- Siding must not be applied to green or crooked structural framing members. Do not apply siding over rain-soaked or buckled sheathing materials.
- Gutters are recommended for control of roof water run off.

### WATER-RESISTIVE BARRIER (WRB)

- A properly installed WRB is required behind siding. Consult I-Codes or local building codes for details.
- LP will assume no responsibility for water penetration.

### SEALANT

- Use a Class 25 or higher exterior paintable, non-hardening sealant meeting the ASTM C920 Standard for Specification for Elastomeric Joint Sealants.
- Follow the sealant manufacturer's instructions for application.

### FLASHING FOR WINDOWS, DOORS & OPENINGS

- All openings must be properly sealed or flashed in a manner that prevents moisture intrusion or buildup. Several examples that accomplish this are shown on the following pages.
- Where siding butts window trim, door casings or corner trim, etc. leave a 3/16 inch (5 mm) gap and seal.

- Where siding butts stucco, brick or cultured stone, etc. leave a 3/8 inch (10 mm) gap and seal.

## KICK-OUT FLASHING

- Install kick-out flashing to direct the water into the gutter.
- Install step-flashing with minimum 4 inch (102 mm) upper leg.
- Properly integrate flashing with a WRB. Use a WRB, flashing tape or other items as needed to maintain the counterflashing principle.
- **DO NOT extend the siding or trim into the kick-out flashing or gutter.**
- Maintain a 1 inch (25 mm) clearance between the end of the gutter and the adjoining wall to allow for proper maintenance of the siding.

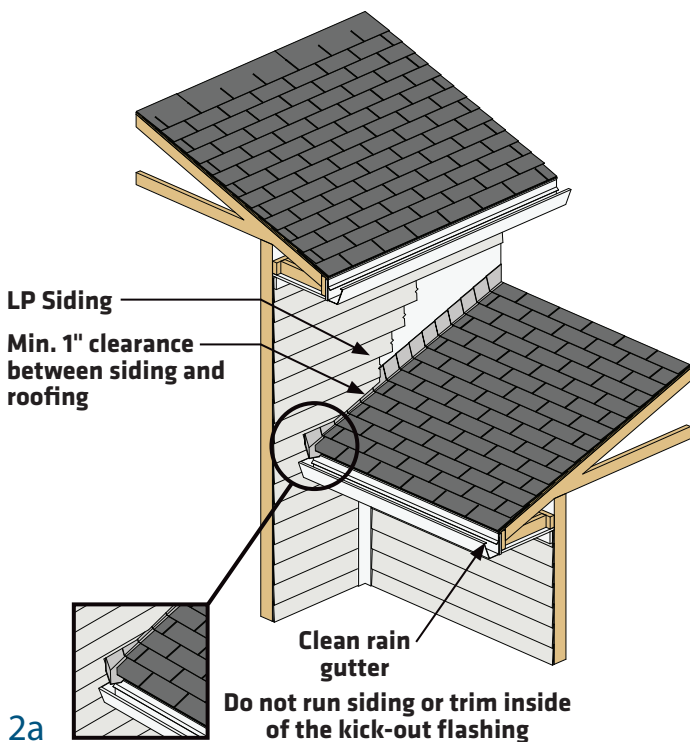

2a

## TRIM

- Trim and fascia must be applied in a manner that will not allow moisture intrusion or water buildup.
- LP® SmartSide® siding is not designed and/or manufactured to be used as trim.
- Trim should be thick enough so the lap siding does not extend beyond the face of the trim.

## FINISHING, CARE AND MAINTENANCE

### Finishing Guidelines:

- Touch up any damage to finish that may occur during application of siding.
- Apply touch up paint to cover scratches less than 1 inch in length and less than 1/16 inch wide, exposed nail heads or small nicks.
- Do not apply touch up paint to spots greater than 3/4 inch in diameter.
- Touch up paint should be used sparingly.
- Apply touch up paint only when air, siding and paint temperature is above 50°F.

- Store touch up paint at temperatures between 40°F and 100°F.
- Shake touch up paint for 90 seconds before every use.
- Do not use touch up paint if you suspect the touch up paint has frozen.
- Do not apply touch up paint to wet siding.
- Avoid touch up painting when condensation is likely to form.
- Avoid touch up painting when precipitation is possible.
- The touch up paint is air dried, while the factory applied coating is cured using ovens. For this reason, the touch up paint will have some minor differences initially and after time. Minimizing the use of touch up paint is the best approach to ensure these minor differences are less noticeable.
- Use appropriate tools provided in the LP SmartSide ExpertFinish® Touch Up Kit.
  - Cut end sealer for cut ends only
  - Nailhead sealer for nailheads only
- For additional touch up paint, please call 888-820-0325

### Care and Maintenance Guidelines:

- Periodic cleaning is recommended to remove dirt and debris that may build up over time. Work a small section at a time, starting from the top and working your way down to prevent streaking.
- First, rinse siding with garden hose using a low pressure spray.
- Next, wash the siding using clean water and mild detergent, apply the solution with a soft brush, cloth or sponge. Do not let the soap dry on the siding.
- Immediately follow all washing by rinsing with a garden hose using a low pressure spray. Make sure to rinse the soap all the way down to the bottom of the house.
- Spot clean and rinse missed areas as needed.
- **Never use harsh or harmful chemicals that can damage the finish on the siding.**

## NAILING INSTRUCTIONS

- LP SmartSide 38 Series lap siding may be attached directly to framing members spaced a maximum of 16 inches (406 mm) o.c.
- Check your local building codes before starting to install siding to confirm if wood structural panel wall sheathing is required.
- Siding butt joints should be staggered over successive courses.
- For siding installations without wood structural panels (WSP), butt joints must occur over stud locations.
- Siding shall be installed using a blind nailing method, with the nails placed per [diagrams 4a or 4b](#).
- Install bottom side of shiplap first. (See [diagrams 4a and 4b](#))
- Avoid sliding or forcing bottom shiplap into place, if top shiplap has been installed first.
- Overlap successive courses a minimum of 1 inch (25 mm).
- Use a minimum 0.092 inch shank diameter, hot-dipped galvanized nail (ASTM A153) or equivalent.
- Fasteners will be exposed on siding located immediately below window sills, etc. (See [diagram 5](#))

CONDITION		CORRECTION	
Snug		OK	
Flush		OK	
Visible fiber		Paint	
Countersunk 1/16" - 1/8"		Apply sealant	
Countersunk more than 1/8"		Apply sealant and re-nail	

### 3a

- A larger nail diameter might be required for some wind speeds or Exposures. Consult I-Codes or local building codes for details.
- All exposed face nails must be caulked and sealed in a manner that prevents moisture intrusion and water buildup.
- Penetrate structural framing or WSP and structural framing a minimum of 1-1/2 inches (38 mm).
- Nail from the center of the siding toward the ends, or from one end to the other end. **NEVER nail from the ends of the siding toward the middle.**
- Shim siding at studs as needed, to avoid drawing siding against uneven walls. Do not overdrive nails. Nail head should seat firmly to face of siding but not be overdriven to distort the siding surface.
- For information on fastening LP SmartSide products in high wind speed areas, refer to ICC-ES Report ESR-1301 or APA PR-N124.

#### Alternate Fastening Option to SIPS or Wood Structural Panel (WSP) Sheathing

- WSP must be a minimum 7/16 Category with an APA Trademark that contains the consensus Standard DOC PS 2.
- 38 Series Strand Substrate lap must be fastened with:
  - Minimum (0.092 inch shank diameter) hot-dipped galvanized ring shank nail, spaced a maximum of 8 inches (203 mm) o.c.
  - Minimum #8 (0.164 inch shank diameter) hot-dipped galvanized tapered head wood screw, spaced a maximum of 12 inches (305 mm) o.c. with minimum penetration of 1/4 inch (6 mm) beyond combined thickness of siding and WSP.
  - Allowed for 16 inch (406 mm) o.c. or 24 inch (610 mm) o.c. stud spacing.

#### Alternative Fastening Option over ICF Wall Assemblies

- 38 Series Strand Substrate Lap must be fastened with:
  - Minimum #8 (0.164 inch shank diameter) hot-dipped galvanized, tapered head, self-drilling screw.
  - Minimum penetration of 1/4 inch (6 mm) beyond the thickness of the nailing flange.
  - Larger screws may be required by the ICF Manufacturer based on the following minimum withdrawal requirements.
- Minimum withdrawal value of the ICF nailing flange must be 50 lbs. with a maximum 12 inches (305 mm) o.c. screw spacing.
- Minimum withdrawal value of the ICF nailing flange must be 31 lbs. with a maximum 6 inches (152 mm) o.c. screw spacing.

#### Alternative Fastening Options over Steel Stud Framing

- Minimum withdrawal value of the steel framing must be 50 lbs. Refer to the framing manufacturer's evaluation report.
- 38 Series Strand Substrate lap must be fastened with:
  - Stud spacing a maximum spacing of 16 inches (406 mm) o.c.
  - Minimum #8 (0.164 inch shank diameter) hot-dipped galvanized, tapered head, self-drilling screw.
  - Minimum penetration of 1/4 inch (6 mm) beyond combined thickness of siding and steel stud framing.
  - Minimum steel framing thickness of 0.032 inch (8 mm) or 20 gauge.

#### Insulated Sheathings

LP SmartSide lap sidings may be installed over low-compression, rigid foam insulation sheathing or exterior gypsum. The following precautions must be followed:

- Adequate bracing of the wall in accordance with the I-Codes or local building codes as required.
- For rigid foam insulation sheathing up to 1 inch (25 mm) thick, siding may be nailed directly through the foam sheathing unless a drainage plane is required by the local building code. Nail length must be increased to ensure a minimum 1-1/2 inch (38 mm) fastener penetration into the structural framing or WSP and structural framing.

### OVERLAP, CLEARANCE & NAILING SPACE

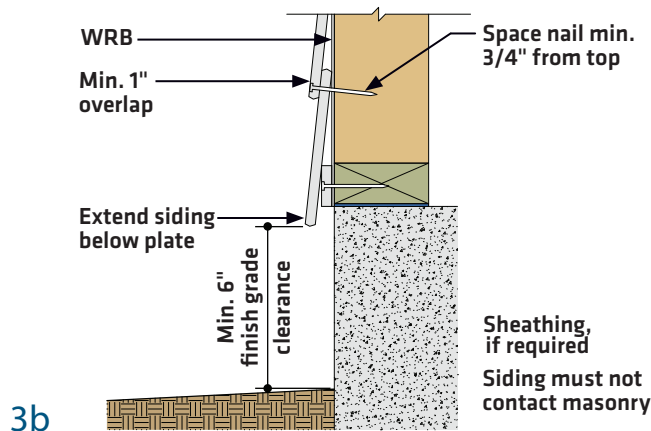

### 1 INCH (25 MM) ROOF & CHIMNEY CLEARANCE

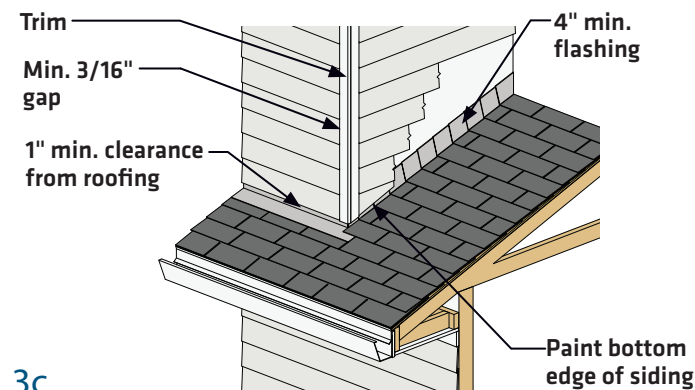

## BUTT AND END JOINTS

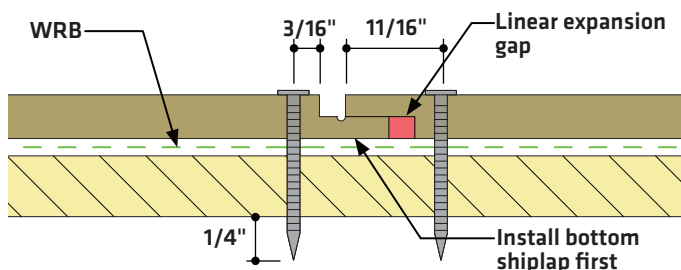

4a SHEATHING ONLY APPLICATION

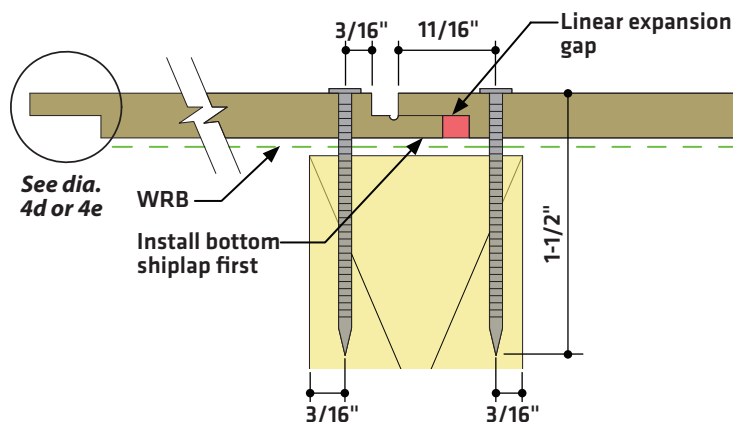

4b DIRECT TO STUD APPLICATION

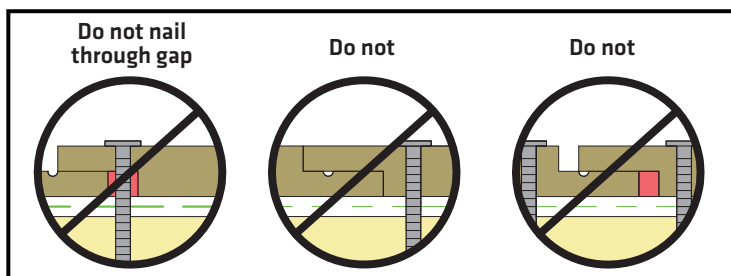

4c

LP Strand Substrate Lap Siding may also be installed in compliance with Category 8140- Exterior wall siding and sheathing for Wildland Urban Interface (WUI) applications atop LP FlameBlock sheathing. Refer to FlameBlock installation instructions and product data sheets. All LP lap sidings may be installed as exterior siding in Wildland Urban Interface (WUI) applications installed over one layer 5/8" (16 mm) Type X gypsum sheathing applied behind the exterior covering or cladding on the exterior side of the framing. They may also be installed over the exterior portion of a 1-hour fire-resistive exterior wall assembly designed for exterior fire exposure including assemblies using the gypsum panel and sheathing products listed in the Gypsum Association Fire Resistance Design Manual.

The Louisiana-Pacific Corporation ("LP") LP SmartSide Siding (the "Products") limited warranty (the "Warranty") applies only to structures on which the Products have been applied, finished and maintained in accordance with the published application, finishing and maintenance instructions in effect at the time of application. The failure to follow such application, finishing or maintenance instructions will void the Warranty as to the portion of the Products affected by the variance (the "Affected Products").

LP assumes no liability for any loss or damage sustained by the Affected Products and is expressly released by the purchaser or owner from any such loss or liability.

Any modification of the Warranty's application, finishing or maintenance requirements is void unless approved in writing by LP prior to application.

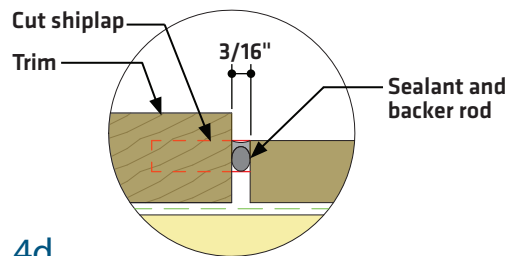

4d

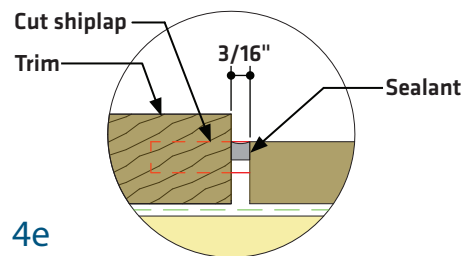

4e

- Caulk/sealant not required
- Butt joints must occur over studs, except for sheathing only applications. (Reference PR-N124 or ESR-1301)
- Seal all gaps at window, door and vertical trim intersections with a high-quality exterior sealant meeting the ASTM C920, minimum Class 25 sealant.
- Shiplap must be removed to full panel thickness and caulked. (See diagrams 4d and 4e)

For a copy of the warranty or for installation and technical support, visit the LP SmartSide product support Web site at:

**www.lpsmartside.com**

or for additional support call 888-820-0325.

WARRANTY REMEDIES ARE NOT AVAILABLE IF REQUIREMENTS ARE NOT FOLLOWED.

**⚠ WARNING: Drilling, sawing, sanding or machining wood products can expose you to wood dust, a substance known to the State of California to cause cancer. Avoid inhaling wood dust or use a dust mask or other safeguards for personal protection. For more information go to [www.P65Warnings.ca.gov/wood](http://www.P65Warnings.ca.gov/wood).**



©2020 Louisiana-Pacific Corporation. All rights reserved. LP, SmartSide and ExpertFinish are registered trademarks of Louisiana-Pacific Corporation. Printed in U.S.A.

NOTE: Louisiana-Pacific Corporation periodically updates and revises its product information. To verify that this version is current, call 888-820-0325.

Figure 5

OVER OPENINGS

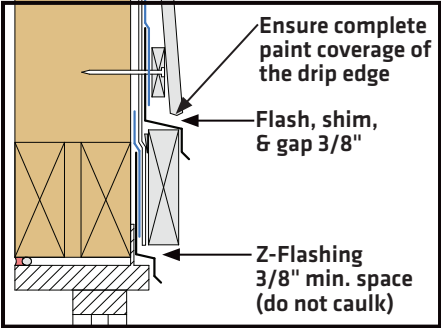

5a

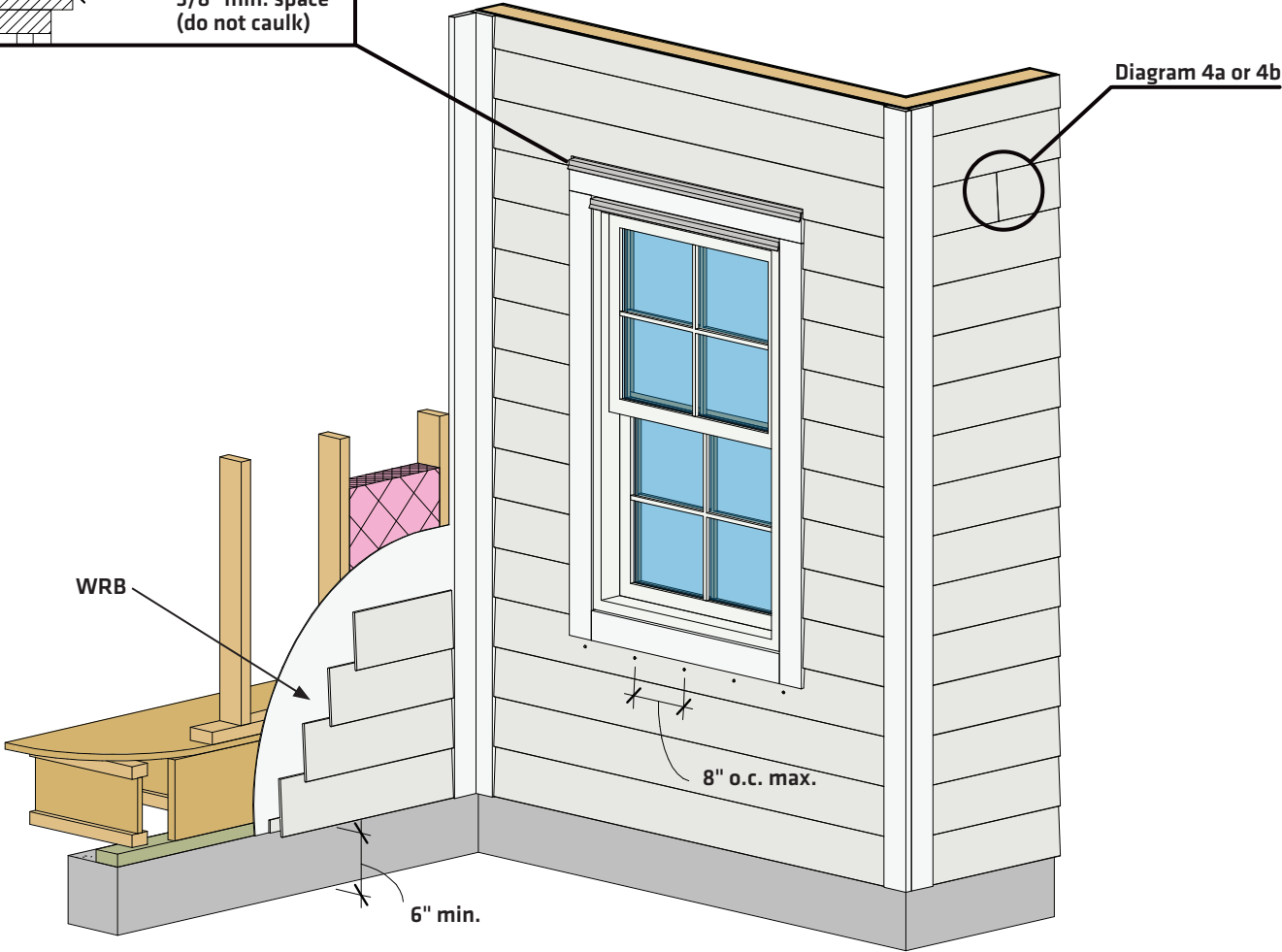

5b

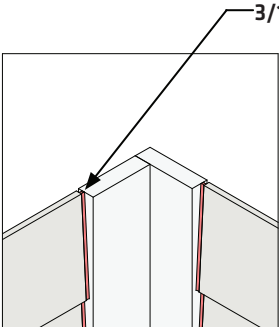

5c

PREFERRED INSIDE CORNER

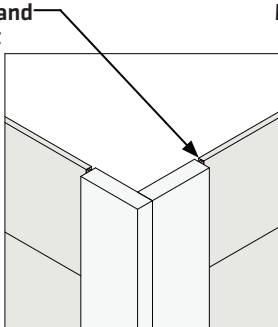

5d

PREFERRED OUTSIDE CORNER

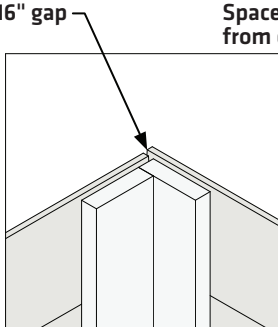

5e

ALTERNATE INSIDE CORNER

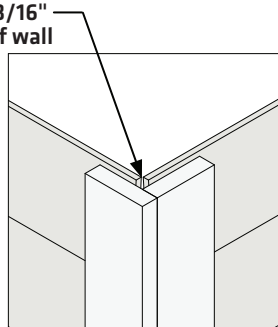

5f

ALTERNATE OUTSIDE CORNER