

GE STEAM POWER

**The Power of Yes.**



[ge.com/power](http://ge.com/power)

# TABLE OF CONTENTS

INTRODUCTION

PLANT INTEGRATOR APPROACH

DIGITAL FOR STEAM POWER PLANT

BOILERS

STEAM TURBINES

GENERATORS

AIR QUALITY CONTROL SYSTEMS (AQCS)

© November 2019, General Electric Company. GE Proprietary Information - This document contains General Electric Company (GE) proprietary information. It is the property of GE and shall not be used, disclosed to others or reproduced without the express written consent of GE, including, but without limitation, in the creation, manufacture, development, or derivation of any repairs, modifications, spare parts, or configuration changes or to obtain government or regulatory approval to do so, if consent is given for reproduction in whole or in part, this notice and the notice set forth on each page of this document shall appear in any such reproduction in whole or in part. The information contained in this document may also be controlled by the US export control laws. Unauthorized export or re-export is prohibited. This presentation and the information herein are provided for information purposes only and are subject to change without notice. NO REPRESENTATION OR WARRANTY IS MADE OR IMPLIED AS TO ITS COMPLETENESS, ACCURACY, OR FITNESS FOR ANY PARTICULAR PURPOSE. All relative statements are with respect to GE technology unless otherwise noted.





**Michael Keroulle**  
President & CEO - Steam Power

The steam power industry has never been more demanding. Operating budgets are tighter and the need for flexibility never more critical. When it comes to our customers' most pressing challenges, GE Steam Power is here to support them. When they come to us for help, our answer is "Yes."

Whether you're building a new power plant or maintaining one that's been running for decades, GE can provide hardware, software and manpower to help keep your plant running optimally, meeting all regulations and delivering power with the right returns. For the past 100 years, we've been a leader in cleaner coal technology and a trusted partner to deliver more value to our customers over the lifecycle of their plants. We are dedicated to technologies that are improving economics, are cleaner, and more sustainable.

Today the newest coal plants being built are using GE's ultra-super critical technology that can deliver 47.5% net plant efficiency rates — significantly higher than the global average of 34%. When you add GE's digital offerings, the results are even more impressive. And as the world's environmental regulations become even stricter, GE's broad portfolio of air quality control systems can help you meet the world's strictest regulations and provide cleaner air for local communities.

With a third of the global installed base each year, we perform more than a thousand outages and partner with our operators around the globe through more than 200 multi-year agreements. We have a hundred years of coal-fired power service expertise across 90+ OEM brands, and 24/7 on-call product support to help keep your power plant up and running. Every day, more than 6,000 field service engineers are on the ground, delivering solutions that ensure a productive future for power plants all over the world.

Can you count on GE to be your full lifecycle partner for coal and nuclear power plants? With local teams and service centers in more than 70 countries around the world, GE brings our global reach and local expertise to help our customers deliver affordable power, local jobs, and better infrastructure to help growing economies. Our employees use a century of steam power expertise to help customers overcome their toughest challenges. It's all about delivering higher efficiency, lower emissions and better economics for our customers around the world.

**This is our commitment to you. This is the Power of Yes.**

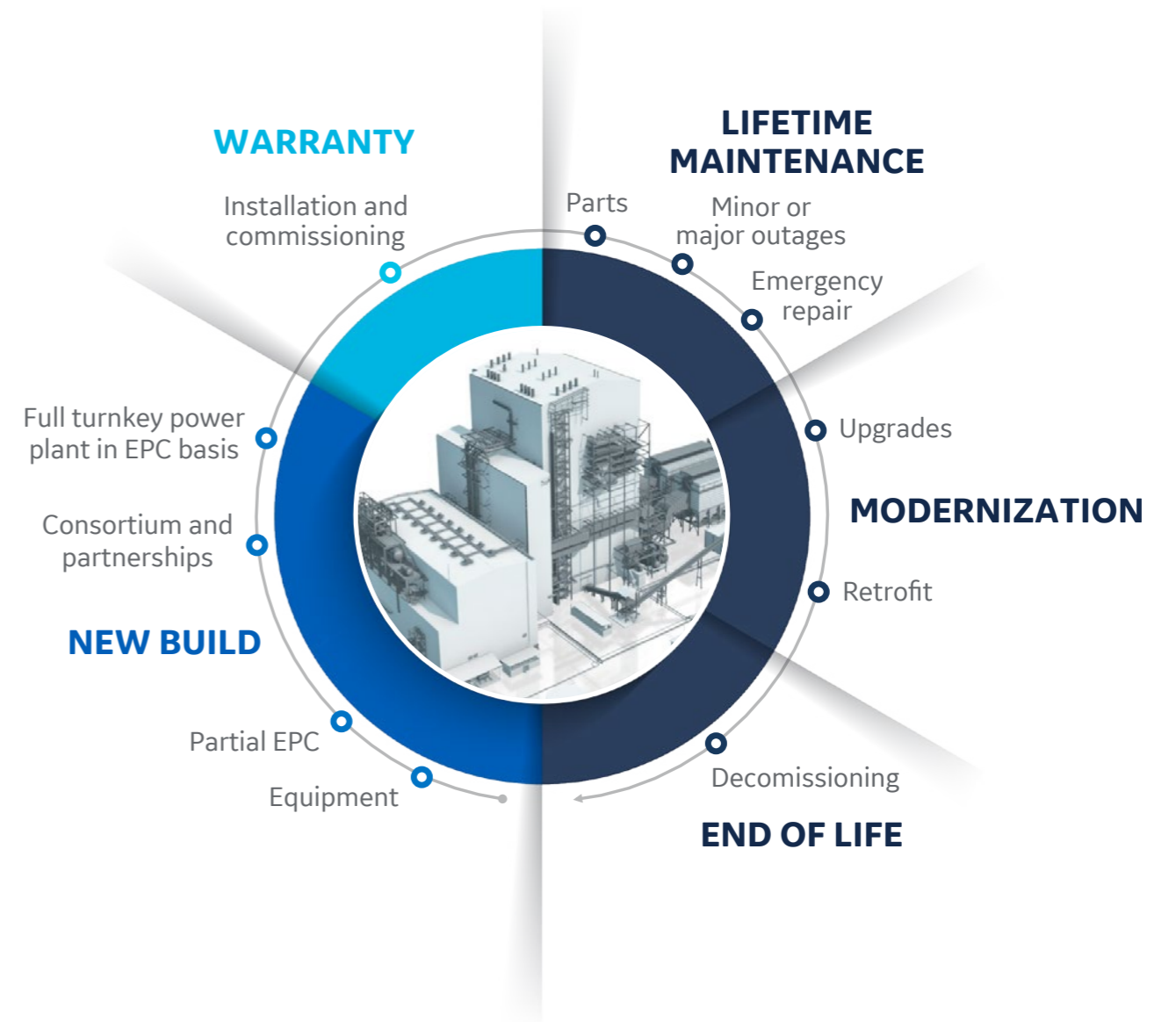

# Future of Coal Power Generation

Using the right mix of technologies which are smarter, cleaner and more sustainable.

The introduction and increasing penetration of renewables is changing the realities of the power market. Coal now has a different, but still very important, role to play in the energy mix, and is helping to enable renewables growth. Whilst nuclear power generation is foreseen to keep the same share of the energy mix in the next 10 years, Coal power generation will decrease to 30%. Yesterday, coal plants were operating in baseload. Today, they are operating in more of a grid response function. Flexible coal power is required to provide around the globe and available energy and balance the grid to support intermittent renewable energy whilst ensuring:

- Grid reliability
- Cost effectiveness (both CAPEX and OPEX, Cost of Electricity)
- Grid operability

## GLOBAL POWER OUTLOOK

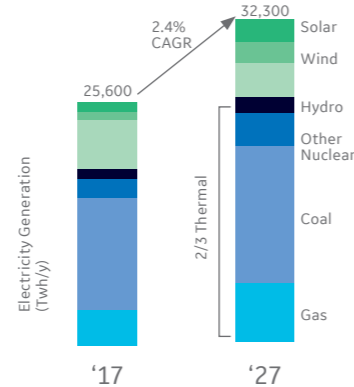

## INDUSTRY DYNAMICS

**Fossil Fuels**  
Remains 60%+ of industry and a must to stabilize the grids

**Renewables**  
Fastest growing segment although still less than 50%

**Emerging Markets**  
85% of electricity growth, each country with unique needs

\*14K from nuclear and coal



## Resources

With nearly 900 billion tons of reserves, coal remains a self-sufficient and affordable means to produce power and provide energy security. This includes using coal as a source of ancillary power in response to intermittent renewable energy sources.

## GE Difference

GE continues to push the limits of our best-in-class steam technology even further. As the economics of power generation have become tighter and regulations become even stricter, GE's technology is ready to respond to growing demands coming from each country and each customer's unique needs.

## Energy Mix

Our goal is to help countries meet their energy and economic development goals, given their local needs. In most countries, this requires an energy mix that includes renewables, gas and coal power generation.

## COAL FORECAST DEMAND OVER THE NEXT DECADE

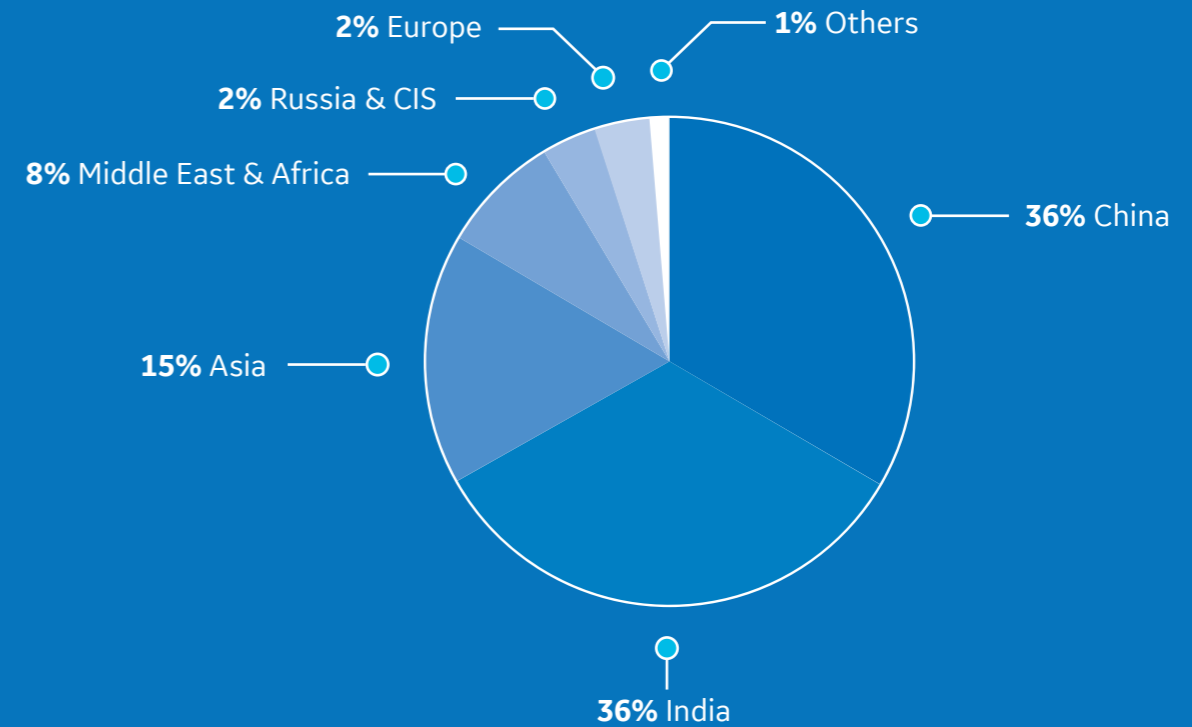

## COAL RESERVES

NOTE: Reserve figures in billion tonnes

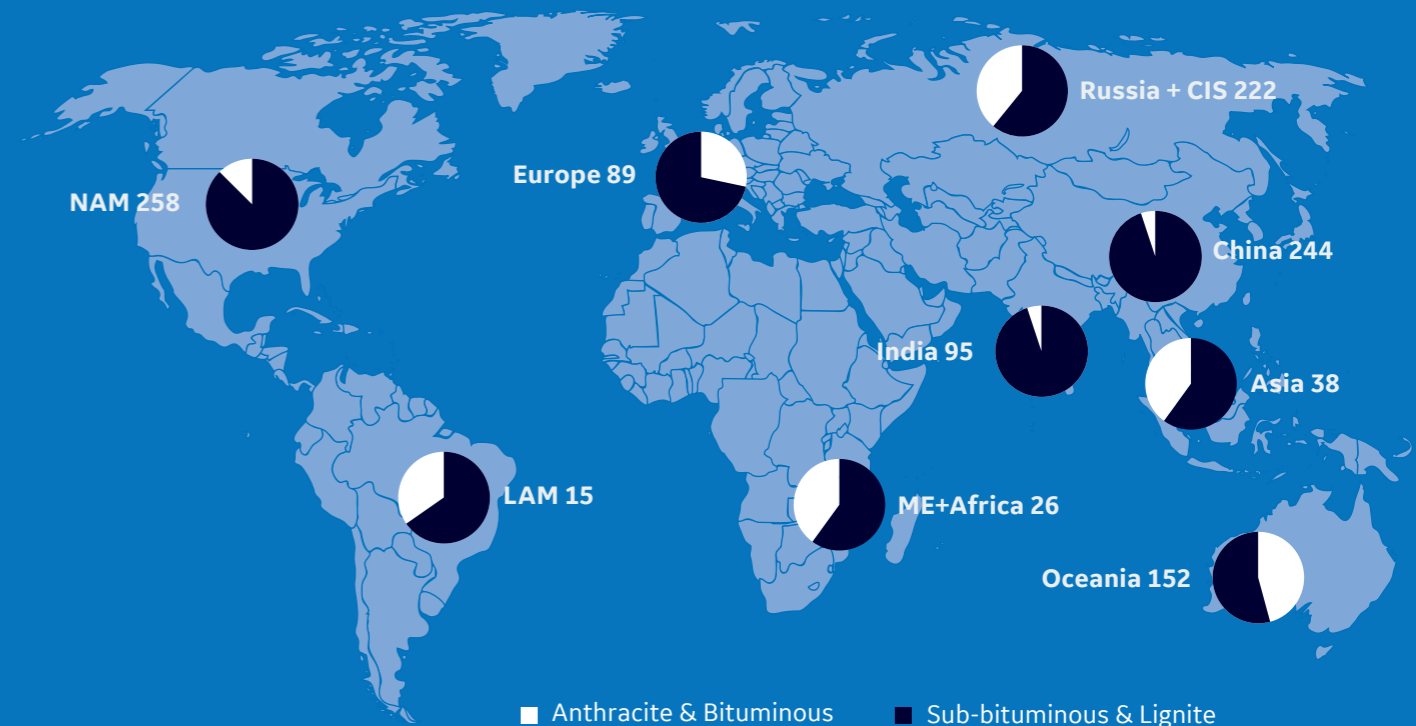

# Your Steam Lifecycle Partner

Local team backed by a global network of steam experts



**100+ Years** of steam power expertise working for you.



**10,000** employees dedicated to our customers.



**#1** Steam business in the world. Powering everyone.

## Delivering More Power & Flexibility

Customers are looking for a partner to help them get the most value from their plant over the complete life cycle. By leveraging GE's global network of unmatched expertise and proven technology, our customers get access to a global force of experts and the largest steam power portfolio in the industry covering 90+ oOEM brands through their local services team.

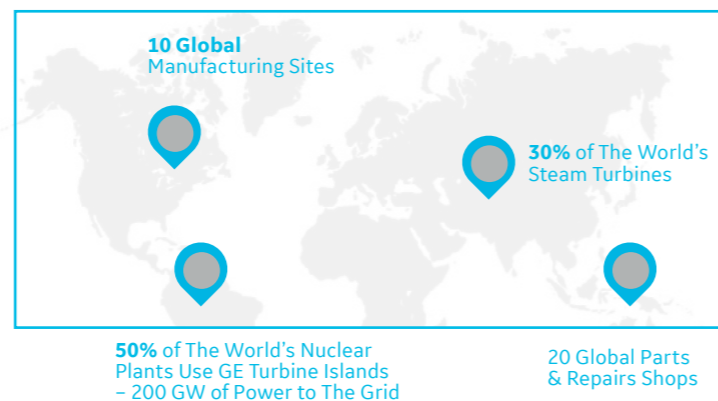

# Coal Portfolio Capabilities

**Integrated offerings**

- Integrated packages (EP)
- Power block/turbine island (EPC)
- Full turnkey (EPC)
- Integrated upgrades

**AQCS**

- Flue-gas desulfurization
- Particulate control
- Mercury control

**Boiler island**

- Two-pass, Tower and CFB technology
- Coal mills
- Primary and Secondary NOx control

**Turbine island**

- Steam turbine
- Generator
- Condensers/heaters

**30%**  
of the world's steam turbine capacity

**30%**  
of the world's boilers

**90+**  
Other OEM brands

The World's Largest Installed Base

Enabling Us to Deliver Each Year to Our Customers

Our Dedicated Community of Experts

# GE's Steam Power Portfolio

From oOEM solutions to partnership and global manufacturing to capabilities.

## Technology

|                |            |
|----------------|------------|
| Steam Turbines | Boilers    |
| AQCS           | Generators |

## Capabilities

|                          |                      |
|--------------------------|----------------------|
| Global parts & repairs   | Other OEM solutions  |
| Operations & maintenance | Software & analytics |

## Partnership

|                                |                             |
|--------------------------------|-----------------------------|
| EPC                            | Multi-year agreements       |
| Global Manufacturing Footprint | Overall lifecycle expertise |

**Overall lifecycle Partner for Steam and Nuclear Power Plants**



- 5000+ steam turbines
- 4900+ generators
- 1000+ boilers
- 4000+ AQCS



- 1000+ outages
- 200+ long-term service agreements
- 100+ steam turbine upgrades
- 200+ robotic inspections
- 50+ generator rewinds
- 50+ boiler upgrades
- 30+ AQCS upgrades



- 24/7 product support
- 10,500 field service representatives
- Complete OEM services partner
- Services for 90+ other OEM brands

Can GE deliver the highest efficiency for my coal power plant?

YES.

The RDK8 steam power plant in Karlsruhe, Germany, has achieved a 47.5% net thermal efficiency while producing 919 MW of electricity. Today, RDK8 is the world's most efficient coal-fired steam power plant thanks to GE's ultra-supercritical boiler and steam turbine generator. With such efficiency, RDK8's plant operator is expected to reduce specific CO2 emissions by 40% and to save 275,000 tons of coal per year, compared to the global average conventional coal-fired fleet.

This is the Power of Yes.



### Technology Milestone

# SteamH

Advanced Ultra-Supercritical Meets Digital Solutions

GE is first-to-market with an advanced ultra-supercritical product. We call this SteamH. GE's SteamH combines the world's leading steam plant technology operating at advanced ultra-supercritical conditions with digital power plant software powered by Predix™.

\*SteamH compared to the best technology in operation today.

# SteamH

Combining the world's leading steam plant technology with GE's digital power plant software.

**GE is first to market with advanced ultra-supercritical technology. We call this SteamH.**

SteamH combines the world's leading steam plant technology operating at advanced ultra-supercritical conditions with GE's digital power plant software powered by Predix - to help customers achieve the highest possible efficiency, lowest emissions and most value over the life of the plant. Available to customers today, GE's SteamH scope of supply covers a broad range of capacity and configurations to meet customer needs, from individual components to full turnkey plants, between 600-1350MW in size. It is based on GE's proven ultra-supercritical design with key components upgraded. With SteamH, GE can deliver more than 15 percentage points of additional efficiency beyond the global average installed base - pushing customers towards 50% efficiency.

### SteamH brings together the Physical and Digital

SteamH pushes the physical limits of GE's proven technology with higher steam parameters (reaching 650 °C), higher efficiency rates (approaching 50% efficiency), and the best materials (T24) that have been proven through more than 30,000 hours of testing in operational power plants. Compared to USC, SteamH delivers better performance, more value to customers and ultimately, more profitable growth; adding up to \$80M net present value over the life of the plant. Furthermore, we have paired our industry-leading steam technology with GE's digital capabilities powered by Predix to deliver better performance, greater efficiencies and improved reliability, at lower cost to the customer.



## What is SteamH and how did we get here?

### BASED ON THE PROVEN USC DESIGN WITH KEY COMPONENTS UPGRADED



660MW to 1,350MW plant at 330bar/650 °C/670 °C maximum cycle conditions

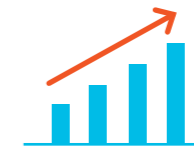

Participation in GER/EU & US programs since late 1990s



Extensive testing:  
Boiler & Piping: >30,000h  
Steam Turbine: >100,000h

**49.1%**

**EFFICIENCY**  
(World Average - 34%)

**30%**

**LOWER EMISSIONS**  
(vs World Average)

### Key Technology Milestones:

**1350MW**

**PINGSHAN II POWER STATION**  
Boiler Selection

**2x800MW**

**YILDIRIM KARABURUN**  
Total Plant Technology Selection

# Digital Capabilities

Enhancing the operating performance of power plants to increase efficiency, lower emissions and reduce cost.

By monitoring, analyzing and organizing data from more than 10,000 sensor inputs across the plant, GE's Digital Power Plant for Steam helps plant operators make smarter decisions about how to optimally run their power plants; achieving better performance, greater efficiency and improved reliability while lowering environmental impact.

Digital Transformation consists of the following practices:

- Connect: Creating the foundation to leverage analytics
- Monitor: Understanding the performance/health of assets
- Analyze: Determining the root causes for effective problem resolution
- Predict: Providing foresight to avoid issues before they occur
- Optimize: Maximizing the performance and profitability

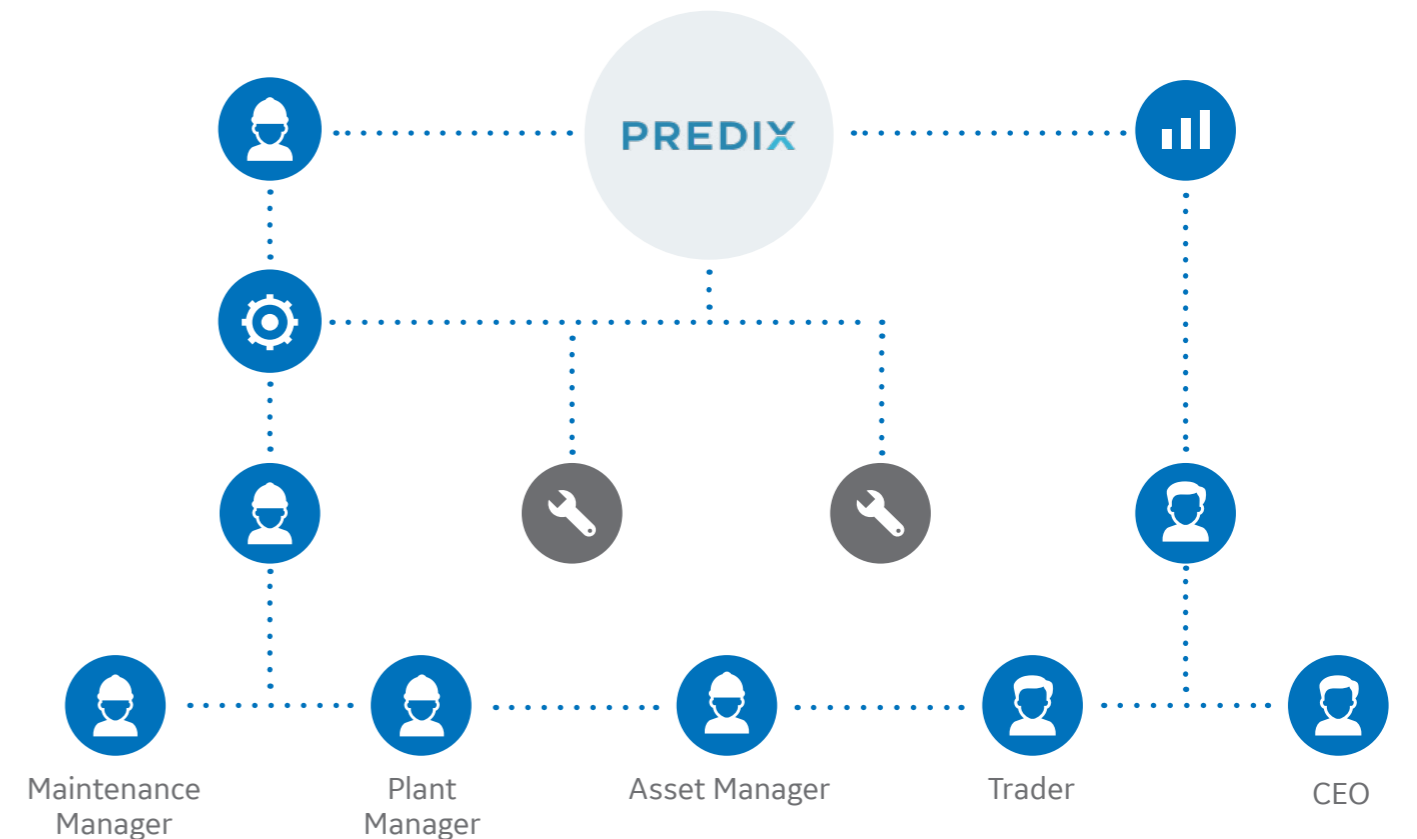
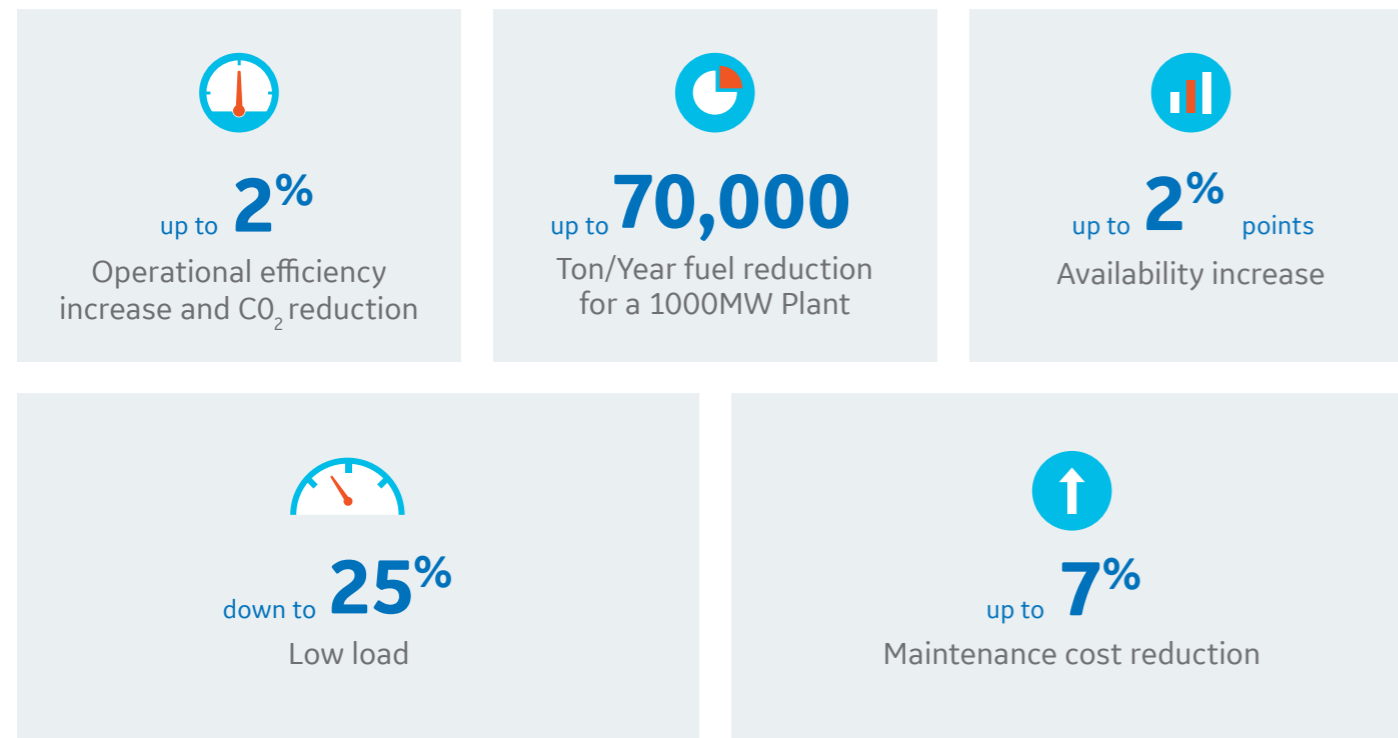



# Guarantees 4.0 with Digital Capabilities

GE offers long term guarantees and improved support for plant operation to reach the best performances in the long run.



up to **2%**  
Operational Efficiency  
increase and CO<sub>2</sub> reduction



up to **2%** points  
Availability Increase

In the past, GE guaranteed output & heat rate at one single performance test performed after delivery of the plant. Today, GE proposes to guarantee electricity production for a given fuel consumption over a period of time.

## Digital Tools make it possible

Long term guarantees are made possible and improved with GE Digital Tool Strategic Planning. This tool allows for the cyclical calculation of different types of heat balances, especially the detailed current status of the plant and status in which it should be (with reference to a benchmark).

## Electricity production and fuel consumption are repeatedly measured and incremented

During the Guarantees 4.0 period (typically 5 to 7 years), the electricity production and fuel consumptions are repeatedly measured and corrected by taking into consideration differences between assumed reference conditions and real measured parameters (air temperature, fuel type, load set point, grid conditions...). The corrected measurements of electricity production and fuel consumption are incremented over each year, and finally compared to the values guaranteed by GE.

During the Guarantee 4.0 period, GE offers an improved support for plant operation and maintenance to reach the best performances in the long run.

GE's Guarantees 4.0 are a game changer:

### Usual Lifecycle

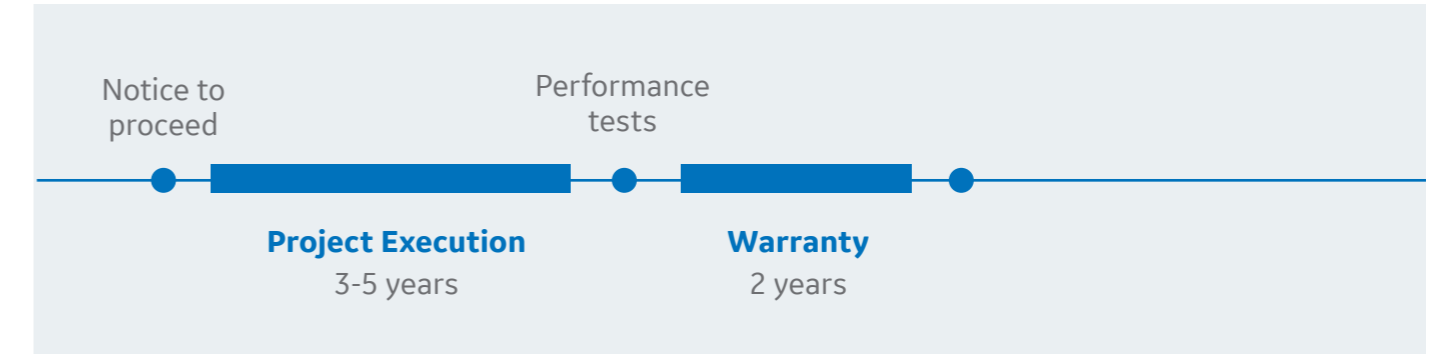

### New Guarantees 4.0 lifecycle

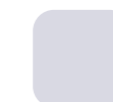
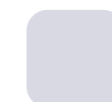
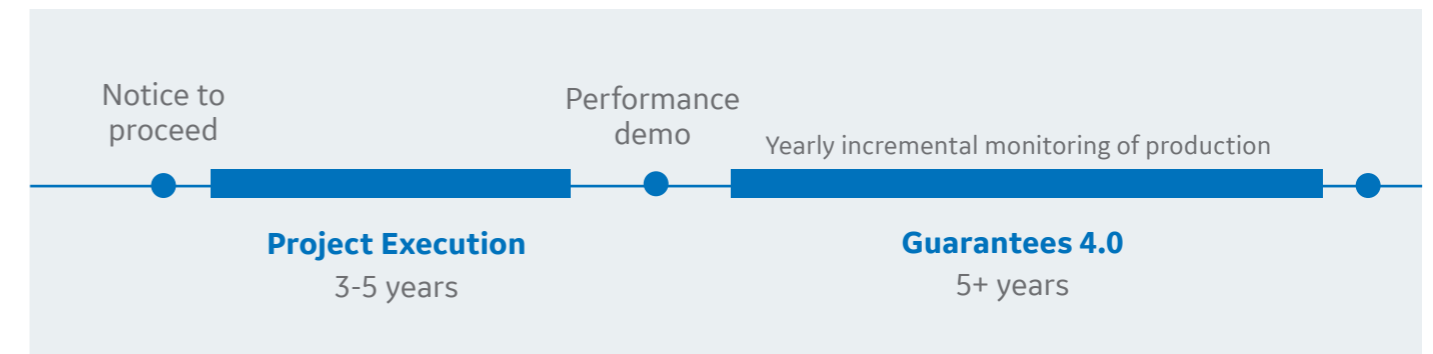

# Air Quality

## Lower emissions mean cleaner air

Many of the world's cities are already suffering from energy related air pollution today. As the world's population grows, with cities swelling and demand for energy surging, there is a need to improve air quality as regulators place even stricter emission limits on power plants and industrial installations.

With 80 years of experience and the broadest range of air quality control systems (AQCS), GE technology can address all the sources of non-greenhouse gas emissions like NOx, SOx and particulate matter from any coal-fired power plant to meet and exceed the world's strictest regulations. In fact, GE's coal plant technology can meet or exceed the same emissions standards for NOx and SOx as a combined cycle gas plant.

■ New emissions limits    ■ GE Steam Power capabilities

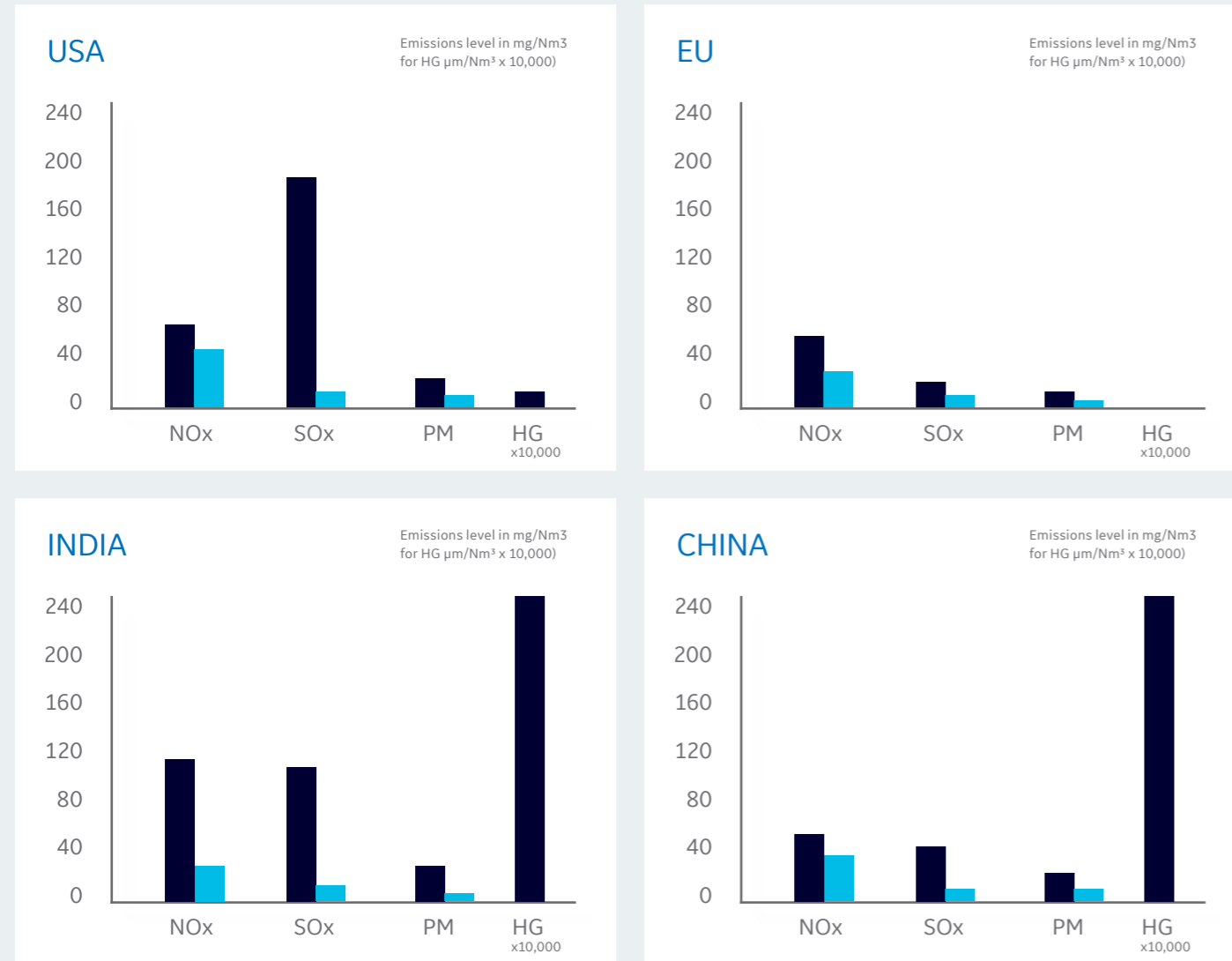

**>95%**  
NOx Removal

**>98%**  
SOx Removal

**>99.9%**  
Particulate Matter Removal

# PLANT INTEGRATOR APPROACH

Our plant integrator approach is based on our ability to combine GE's components and auxiliary equipment into fully enhanced and integrated systems.

## Maximizing efficiency and ensuring compliance with the strictest emissions regulations

The return of experience from manufacturing, construction, commissioning and operation results in a systematic continuous improvement of GE's components and standardized/pre-engineered solutions.

This leads to improved performance, as well as cost and delivery time reduction of our offering to our key markets and helps our customers achieve and exceed their objectives. Under the Plant Integrator approach, GE Power ensures the optimization of the power plant performance to reduce fuel consumption by maximizing efficiency and ensuring compliance with the strictest emissions regulations.

### 1. Boiler Island

Boilers for all fuels: Coal, Oil, Gas, Two-pass, Tower & CFB Tech. Coal Mills. NOx control: SCR systems.

### 2. Turbine Island

Steam turbine, Generator, Condensers/Heaters.

### 3. AQCS:

- a Flue Gas Desulphurization
- b Particulate Control
- c Mercury Control



### Integrated offerings

- ✓ Integrated packages (EP)
- ✓ Power block / Turbine island (EPC)
- ✓ Full turnkey (EPC)

### Extensive execution experience

**100+**

Years of experience in building steam power plants, making GE a global leader

**100+**

Gigawatts installed integrated power

**200+**

Integrated projects executed globally

## Integrated steam platforms (ISP)

GE has a systematic approach to developing standardized and pre-engineered components and power plant designs, while keeping sufficient flexibility to meet our customers' needs. This approach enables us to improve the manufacturing, assembly, construction, commissioning, operation and maintenance of the power plant, which results in improved reliability and availability of our offerings.

For each major segment of the market, GE has created a pre-engineered plant approach which delivers solutions matching specific needs coupled with competitive cycle times during offering and execution phases.

| Plant   | Steam cycle |                        |                   |                   |                     |
|---------|-------------|------------------------|-------------------|-------------------|---------------------|
|         | MW Class    | Cycle                  | P <sub>main</sub> | T <sub>main</sub> | T <sub>reheat</sub> |
| 150 MW  | USC         | 250 <sup>Bar</sup>     | 600°C             | 620°C             |                     |
| 350 MW  | USC         | 300 <sup>Bar</sup>     | 600°C             | 620°C             |                     |
| 660 MW  | A-USC       | 275-330 <sup>Bar</sup> | 600-650°C         | 620-670°C         | 620-670°C           |
| 800 MW  | A-USC       | 275-330 <sup>Bar</sup> | 600-650°C         | 620-670°C         | 620-670°C           |
| 1350 MW | A-USC       | 275-330 <sup>Bar</sup> | 600-650°C         | 620-670°C         | 620-670°C           |

These integrated steam platforms (ISP) make extensive use of standardization and design-to-cost, while still maintaining sufficient flexibility to meet individual project requirements.

## Product portfolio

The benefits of this approach to our clients are multifold:

### BUILT-IN FLEXIBILITY

To address most of the site and project specific conditions (fuels, codes and standards, cooling media, emission limits).

### IMPROVED HEALTH & SAFETY

Safer to construct and safer to operate.

### OPERATION & MAINTENANCE

Easier to maintain, leading to improved availability.

### IMPROVED QUALITY

Re-use of proven solutions and design principles combined with continuous improvement, systematic return of experience, and lessons learned from tendering, engineering and execution.

### REDUCED DELIVERY TIMES

Quicker response to customer requests during the tender phase, and reduced construction and commissioning time.

### EMISSIONS REGULATION

Each ISP is capable of meeting today's most stringent local, regional or global emissions requirement.

## 150MW & 350MW Plant Class USC

There continues to be a demand for steam plants in 150MW and 350MW classes. These plants can be built closer to the point of consumption. They can also react to the increasingly variable grid demands that are imposed by a growing penetration of renewable power generation.

GE has now taken the next step in developing the new generation of those plants. We have implemented our proven USC design to the 150MW and 350MW classes of power plant.

We now achieve a plant efficiency that is as much as 2.5% pts better than the previous generation of these plants. This efficiency is on-par with that of the best steam plants in operation today, regardless of the size.



PLANT INTEGRATOR APPROACH

# FLEXIBLE OFFERINGS

Freedom to fulfil individual customer requirements.



## The OEM with the full in-house product capability from conceptualization to final design.

GE applies the concept of flexible offerings across our portfolio, allowing our customers to select from a portfolio of products and systems that meet their specific requirements, while maintaining the key benefits of standardization and pre-engineering processes.

In addition, GE's Plant Integrator approach can deliver added value across the full range of offerings.

### Integrated offerings. Flexible scope

GE has a systematic approach to developing standardized and pre-engineered components and power plant designs, while keeping sufficient flexibility to meet our customers' needs.

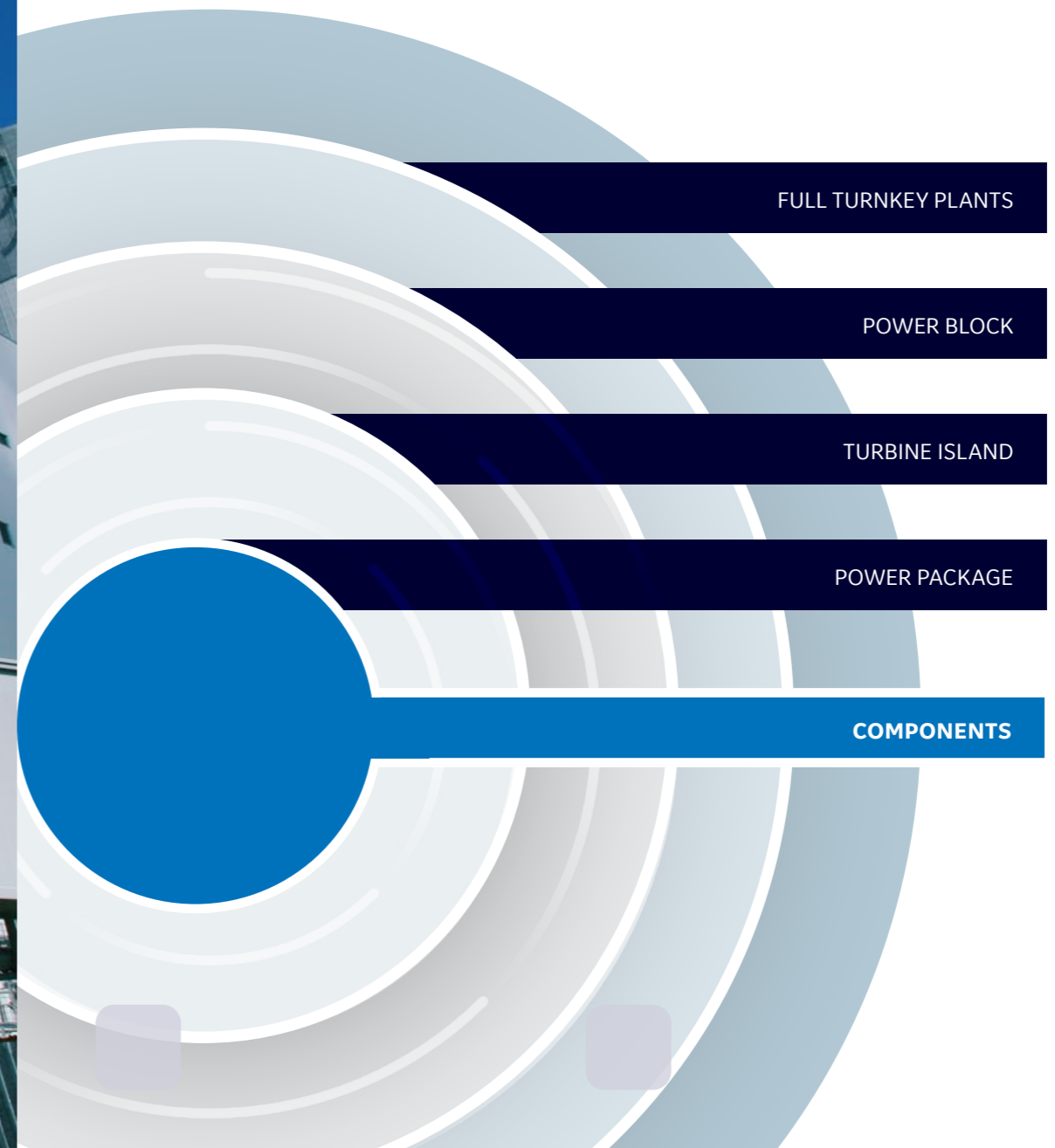

PLANT INTEGRATOR

# Integrated power packages (i.PP) - ideal solution for competitive EPC contractors

Whether you are a power plant owner or an EPC contractor, sourcing the main power generation equipment for your new build project is the most important decision you will make.

GE's i.PP supplies our customers with our world-class boilers, turbines and generators, all of which have been conceptualized to operate as one unit, allowing us to provide excellent performance and power output. With our flexible offerings concept, customers can add additional GE equipment, providing them with enhanced quality and performance.

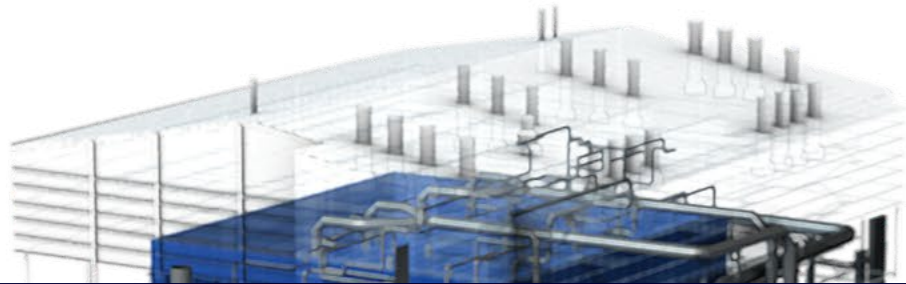

## Scope of offering

### Parts

- Boiler (core parts)
- Steam turbine
- Generator
- AQCS (optional)

### Service

- Integration
- Construction
- Commissioning
- O & M

### Performance

- Overall Performance Guarantee**
- Power output
  - Heat rate
  - Emissions



## Saudi Arabia

5 x 620 MW Integrated power package (i.PP)

### Product

620 MW supercritical heavy fuel oil (HFO) and gas-fired (dual fuel) power plant

### Scope

- Integrated power package (i.PP) including AQCS
- Boiler, steam turbine, generator
  - Electrostatic precipitators and flue gas desulfurization system
  - Basic engineering of the power block
  - Technical field services for erection & commissioning
  - CO<sub>2</sub>- capture ready

### Benefits

- Overall performance and emission guarantees (power output, heat rate, emissions)
- Steam extraction for desalination

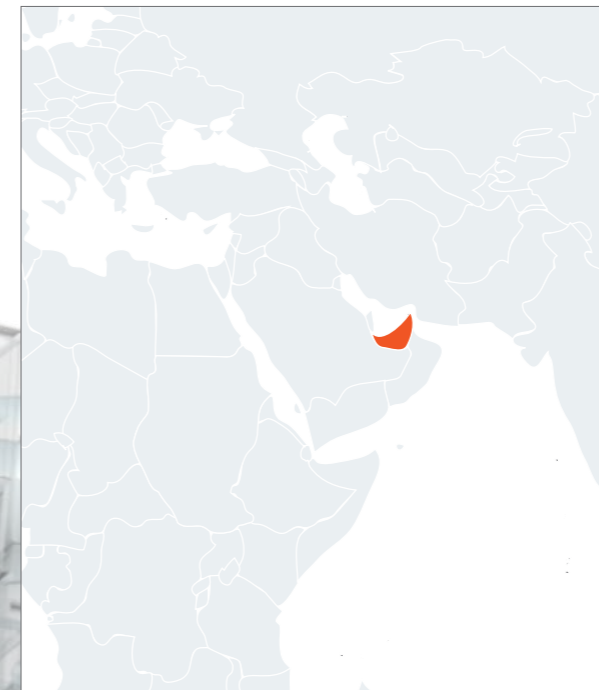

## United Arab Emirates - Case Study

4 x 660 MW Integrated power package (i.PP)

### Product

660 MW (gross) USC coal-fired steam power plant

### Scope

- Integrated power package (i.PP) including AQCS extended with grid code compliance package
- Boiler, steam turbine, generator
  - Electrostatic precipitators and flue gas desulfurization system
  - Basic engineering of the power block
  - Overall operating concept
  - Main equipment of the water & steam cycle
  - Advisory and site services
  - Commissioning

### Benefits

- Overall performance and emission guarantees (power output, heat rate, emissions)
- Compliance with stringent grid code requirements
- Generator support for optimized technical solutions with the most attractive tariffs

Contributes to **90 %** of the plant performance, using just the core OEM components

# One of the most critical parts of the power plant

## Turbine island

The turbine island is one of the most critical parts of the power plant, and of prime importance is the integration of key parameters and interfaces among the auxiliary components and steam water cycle.

With proven equipment and systems, the plant is able to consistently deliver the desired output throughout the product's life cycle. GE's flexible offering allows for excellent layout of the turbine hall, providing significant savings in construction and labor costs.

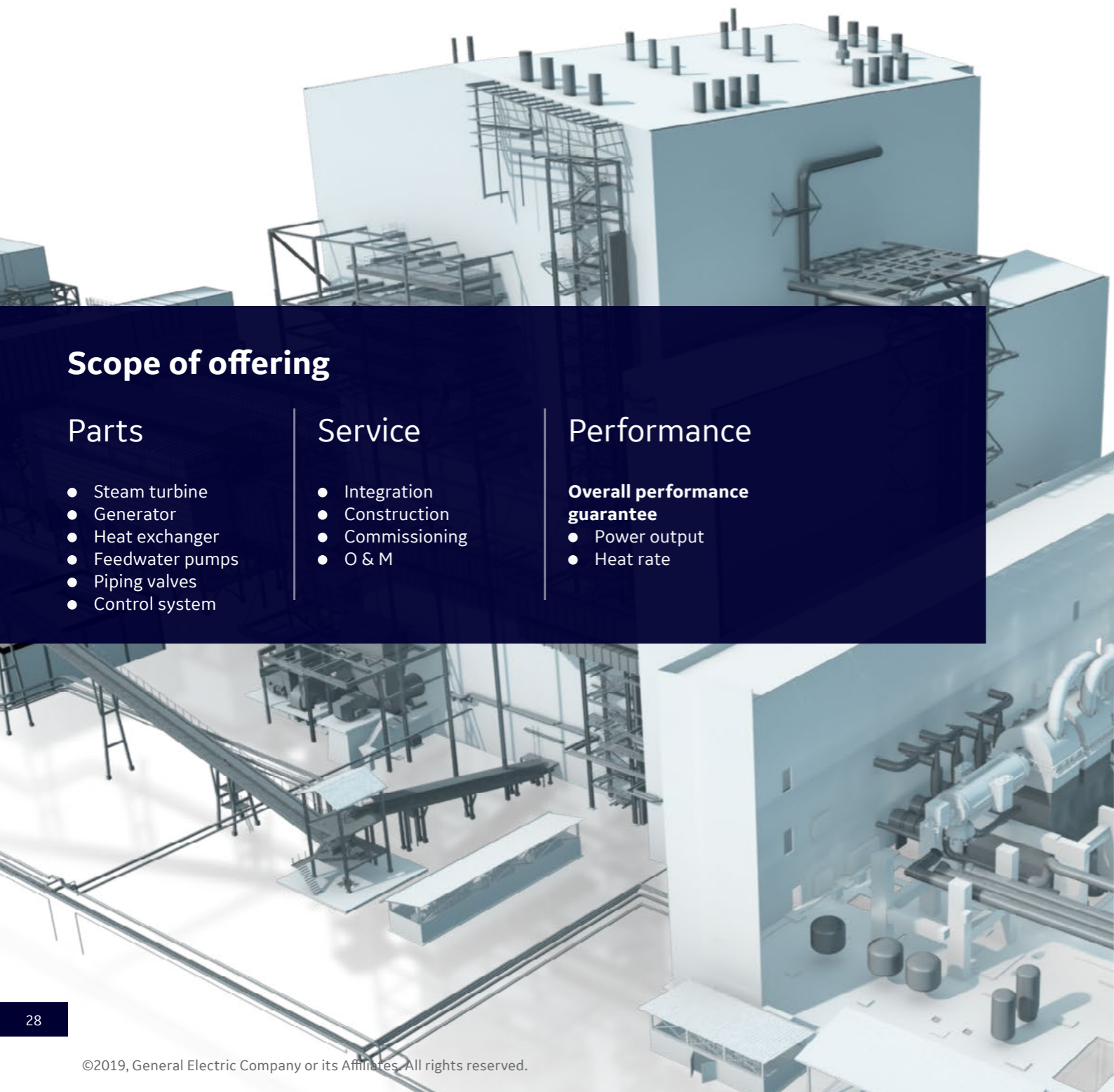

### Scope of offering

#### Parts

- Steam turbine
- Generator
- Heat exchanger
- Feedwater pumps
- Piping valves
- Control system

#### Service

- Integration
- Construction
- Commissioning
- O & M

#### Performance

- Overall performance guarantee**
- Power output
  - Heat rate

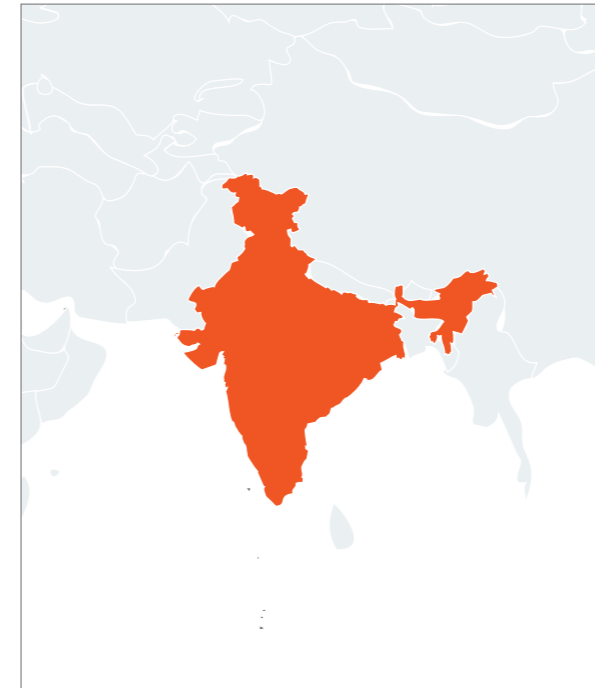

### India

7 x 660 MW SC turbine islands

#### Product

660 MW turbine island

#### Scope

- Steam turbine and auxiliary equipment
- Generator and auxiliary equipment
- Condensate system
- Feed water system
- Control, protection and instrumentation
- Construction and commissioning

#### Benefits

Integrated and enhanced systems meeting Indian requirements

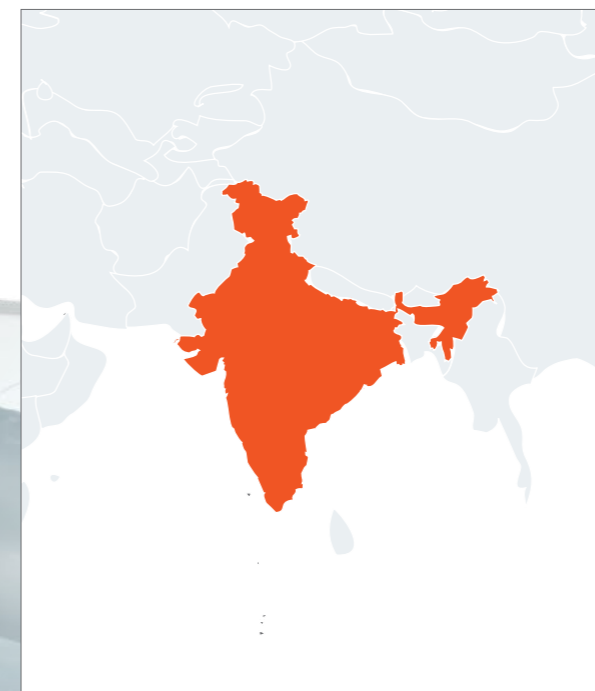

### India

2 X 800 MW USC turbine island

#### Product

660 & 800 MW turbine island

#### Scope

- Steam turbine & auxiliary equipment
- Generator & auxiliary equipment
- Condensate system
- Feed water system
- Control protection and instrumentation
- Construction and commissioning

#### Benefits

Higher efficiency USC steam parameters and larger unit size while still meeting Indian requirements

Providing critical OEM steam turbine, generator and enhanced water steam cycle interfaces

# Design and integration of all critical equipment and systems at the power plant level

## Power block

One of the most complicated and critical challenges of integration in a plant is the power block. The power block consists of the power plant's critical equipment including boiler, steam turbine, generator, air quality control systems and associated auxiliary systems. Integration is key to plant performance over its lifetime and provides a quicker and lower risk return on investment.

However, successful integration requires a global footprint and world-class EPC capabilities. GE's competitive power block offering is based on our extensive global experience integrating key components with varied scope of supply and our proven solutions.

### Scope of offering

#### Parts

- Full boiler island
- Full turbine island
- AQCS equipment

#### Service

- Integration
- Construction
- Commissioning
- O & M

#### Performance

- Overall performance guarantee**
- Power output
  - Heat rate



### Poland - Case Study

Opole 5&6, PGE  
2 x 900 MW USC power block

#### Product

900 MW coal-fired, ultra-supercritical power plant

#### Scope

- Boiler island equipment
- FGD and ESP area
- Turbines, generators and turbine hall equipment
- Handling systems (coal, ash and slurry)
- Plant Engineering
- Overall Project Management
- Construction support
- Commissioning

#### Benefits

- High efficiency (over 45%)
- Meets stringent european emissions regulation: sulfur dioxide (SOx), nitrogen oxides(NOx) and particulate matter



### Germany - Case Study

RDK8, EnBW  
1 x 912 MW USC Power Block

#### Product

912 MW coal-fired, ultra-supercritical power plant

#### Scope

Power block: Boiler and turbine islands

#### Benefits

- Overall net plant efficiency over 47% (up to 58% % with district heating)
- Meets stringent european emissions regulation:
  - CO < 740 g/kWh
  - CO and NOx < 100 mg/Nm3

**One of the highest efficiency steam power plants in the world**

# Design and integration of all critical equipment and systems at the power plant level



# Provides the full GE advantage over the life cycle of the plant

## Full turnkey plant

Today's plant owners and power operators know that it takes more than selecting a set of high efficiency components to achieve advanced economic and technical goals. In order to maximize long term returns on investment, it takes a company like GE, with extensive experience and world-class EPC capabilities – such as project management, logistics, and construction management.

GE's range of capabilities in design and integration of steam power plant solutions gives us a unique perspective that allows us to analyze the entire plant over its full life cycle as an integrated system.

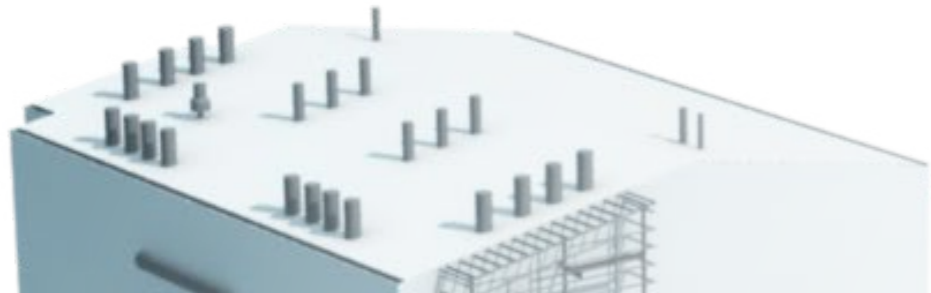

### Scope of Offering

#### Parts

- Full power block

#### Service

- Integration
- Construction
- Commissioning
- O & M

#### Performance

- Overall performance guarantee**
- Power output
  - Heat rate

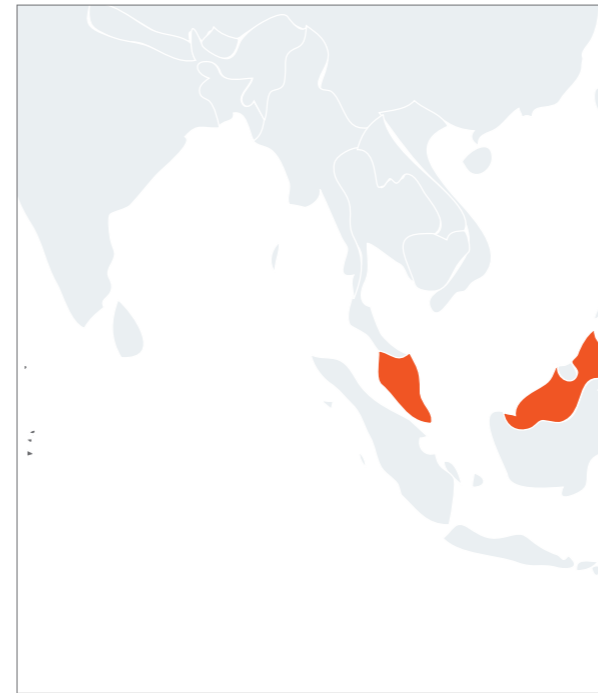

## Malaysia - Case Study

Manjung 4, TNB  
1 x 1,080 MW Gross USC coal plant

#### Product

1,080 MW coal-fired, ultra-supercritical power plant

#### Scope

- Boiler island including FGD and ESP
- Turbine island including turbine hall equipment
- Balance of power block
- Construction and commissioning support

#### Benefits

- High efficiency
- Meets stringent emissions regulation: sulfur dioxide (SO<sub>x</sub>), nitrogen oxides (NO<sub>x</sub>) and particulate matter



## Poland

Belchatow, PGE  
1 x 858 MW Gross USC lignite plant

#### Product

• 858 MW coal-fired, ultra-supercritical power plant

#### Scope

- Full turnkey steam power plant

#### Benefits

- Higher efficiency (close to 42%)
- Lower emissions of sulfur dioxide (SO<sub>x</sub>) and nitrogen oxides (NO<sub>x</sub>)

**Poland's largest and most efficient lignite-fired plant.**

Enhanced economics, shorter lead times, extended performance and reduced O&M costs

## Our partnership with Chinese EPCs

GE Steam Power has partnered with China's power industry for more than 50 years, and made great contributions to its rapid development. Following the acquisition of Alstom's energy business, GE Steam Power's product line has expanded and its strengths significantly enhanced. The combination of both parties' products, technologies, and experience has further improved the operations and efficiency of existing units.

GE has earned a good reputation both in China and in overseas markets for its product quality and exceptional performance. GE has world-class manufacturing bases for boilers, turbines, and generators in Wuhan and Beijing, and has become one of the "Big Four" Chinese power equipment suppliers.

Global coal reserves total approximately 900 billion tons, and coal remains an important component of energy supply. Presently, about 40% of global electric power is generated by coal-fired power plants. Developing countries along the Belt and Road need power to support local economic development, and coal-fired power plants remain the first choice for these markets.

GE Steam Power have participated in many EPC projects all over the world, providing electric power for millions of people. GE's advanced steam power generation technologies, products, and solutions are widely used in many important large coal-fired power generation and nuclear power projects. GE is in a leading position in terms of its ultra-supercritical technology with an efficiency of over 47%, much higher than the industry average.

## Case Study

Since 2010, GE Steam Power has closely cooperated with Chinese EPCs, and the Malaysia Manjung 4 Power Plant Project is the first overseas project in which GE Steam Power worked in consortium with Chinese EPCs. In 2016, the cooperation between GE and Chinese EPCs reached a new level, with more and more "Made in China" GE products being used in overseas EPC projects. GE is committed to working closely with Chinese partners to achieve win-win results in their overseas projects.

### Dubai Hassyan Clean Coal Project

GE worked together with HEI to supply an integrated power plant solution to the Middle East's first ultra-supercritical coal-fired power generation project – the Hassyan Project. The 4x600MW power plant will be fitted with GE's high efficiency ultra-supercritical technology, including boilers, steam turbines, generators and other equipment, with environmental control systems as well as project management support.

### Pakistan Hubco Coal-Fired Power Plant Project

The Pakistan Hubco Coal-Fired Power Plant project is invested by SPIC China Power International, and the EPC contractors are Energy China NEWPEI and TEPC. The total investment of this project is US\$2 billion, and commercial operations are expected to begin in 2019. Hubco is the first overseas coal-fired power plant project in which China Power International has invested with a controlling stake. GE will provide two sets of 660MW supercritical boilers, steam turbines, and steam turbine-generator products.

### Pakistan Thar II Power Plant Project

The Thar II Project (EPC: CMEC) is an independent power generation project of the Pakistani government. GE will provide the Engro, Hubco, and Habib projects of Thar Co., Ltd. with four 330MW CFB boilers. Both parties welcomed an important milestone in this project - GE delivered critical equipment for boilers, including cyclones, water walls, tubes sections, soot blowers, and air preheaters on July 6, 2017.

### Malaysia Manjung Coal-Fired Power Plant Project

The Malaysia Manjung Coal-Fired Power Plant Project is invested by TNB. It is the first 1,000MW ultra-supercritical coal-fired power plant in Southeast Asia and is also the first 1,000MW overseas project by a Chinese EPC company. GE was the EPC contractor together with its consortium partner, CMC (a subsidiary of Genertec), for this power plant. GE Steam Power' world-class EPC capabilities allowed the project to be delivered on time and within budget, and was recognized by awards from Asian Power and the International Project Management Association for the project.

### Pakistan Lucky Power Plant Project

The project invested by Lucky Electric Power Company will be the first 660MW ultra-supercritical power plant in Pakistan and the first lignite-fueled ultra-supercritical power plant across the Middle East, North Africa and Turkey region. SEPCOIII and GE bring together GE's industry-leading technologies with SEPCOIII's outstanding management skills and execution resources. GE Boiler design is specifically suited for generating power from Thar lignite, a fuel that is challenging to use because of its high moisture content.

The new power plant will provide 660 megawatts (MW) to the national grid, the equivalent power needed to supply up to 1.3 million Pakistani homes and industries.



# DIGITAL SOLUTIONS

## Industry in Transition

The electricity industry is undergoing a transformation. Old approaches and techniques are no longer viable—triggering the need for widespread change in the power industry: from grid supply to consumption. By embracing digitalization, companies can apply unprecedented insights, new capabilities and innovative business models to capture enormous opportunities across the entire Electricity Value Network.

## Digital Solutions

With the growing renewables generation, new regulatory requirements, and numerous other fluctuating conditions, operational needs and business models are continually evolving. Much like operational flexibility, digital is a crucial consideration that affects power plant design and component selection. The convergence of hardware, digital software, and advanced analytics is disrupting the status quo and ushering in a new era where reactive becomes predictive, and limits get pushed to new heights.

GE's Industrial Internet capabilities are positioning plant and fleet operators to harness and monetize in ways like never before. One example is the Digital Power Plant, a suite of hardware and software solutions that enable our customers to optimize all the critical components to adapt to changing market conditions. Our platform of apps and analytics adds the power you need to break through new barriers in performance, predictability, and profitability.

## GE Power Digital Solution Map

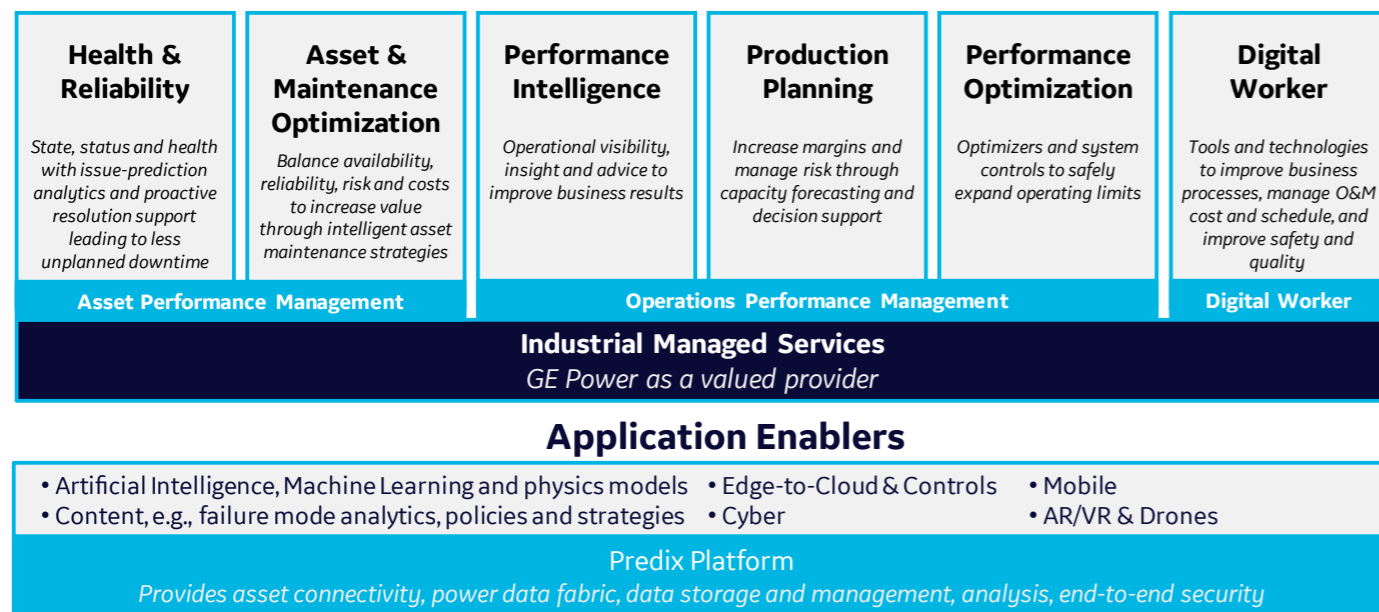

## Our solutions include:

|  |   |
|--|---|
| <b>ASSET PERFORMANCE MANAGEMENT</b>      | Enables the improvement of asset reliability and availability while reducing risk and maintenance costs. It connects historical data, real-time machine data, and other disparate data sources and applies advanced analytics, including physics-guided machine and deep learning, to deliver actionable insights. By predicting potential equipment failures and quickly diagnosing related issues, APM reduces unplanned downtime and improves availability. Additionally, the software helps develop customized maintenance strategies that enhance plant reliability while reducing overall maintenance needs |
| <b>OPERATIONS PERFORMANCE MANAGEMENT</b> | Provides critical decision support and improves productivity by pushing the operating envelope to capitalize on more economic operations for every plant in the fleet. Enabled by edge-to-cloud technology, the solution analyzes historical, plant, and other data sources to deliver executable advice or close the loop and drive desired outcomes for better efficiency, flexibility, and reliability.  |
| <b>DIGITAL WORKER</b>                    | Augment the abilities of workers of every skill level. Mobile service delivery solutions, paired with predictive analytics, give workers the information they need, when they need it, whether remotely or on-site, and enable greater collaboration with other workers to accelerate knowledge sharing.  |
| <b>CYBER SECURITY</b>                    | GE's expertise in operational technology cyber security can help power companies and utilities plan, design and build operational resilience into people, processes and technology. GE uses a cohesive risk management approach to address cyber security challenges throughout the evolution of a company's security maturity.   |

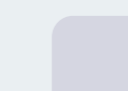
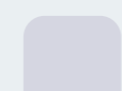

## Delivering Outcomes through Digital solutions

Our digital solutions combine hardware and/or sensors, new optimization algorithms/solvers, intuitive User Interface (UI) features, and an edge-based, Industrial Internet Control System (IICS), and Supervisory Control Servers to provide enhanced guidance and supervisory control on how to efficiently operate a steam power plant across the load range.

GE's Digital solutions deliver the following outcomes:



### Efficiency

**Is your plant delivering on your desired business outcomes through enhanced efficiency?**

The growing mix of renewables, volatile fuel prices and emergence of competitive applications globally requires today's power generation fleet to run more efficiently than ever before. Plants facing variable fuel prices, fuel quality and load levels are adopting new approaches to improve efficiency and reduce operating costs. GE's Digital Solutions can help your plant achieve better efficiency results with more frequent dispatch, more attractive margins and lower fuel costs.



### Reliability & Availability

**Is your plant providing the information and insights you need to proactively manage key performance metrics?**

As the power industry faces a complex set of new dynamics and emerging disruptive forces to the operating environment, the expectation to maintain high reliability and availability benchmarks remains. Incentive and penalty levels associated with achieving these benchmarks are increasing in many regions. GE's proven technologies can help your plant meet rising performance expectations.



### Flexibility

**Is your plant configured and controlled for enhanced cyclic operation?**

Caused by liberalization of the power market and the increased market share of renewable energy, today's power plant and fleet requirements have changed towards an increased flexibility, which is essential when responding to the challenges of grid fluctuations and fuel price volatility. Plants are increasingly focused on increasing revenue during high demand while decreasing costs when demand is low. With cutting-edge tools and data-driven insights, GE can unlock new opportunities to increase your plant's flexibilities, such as lowering minimum load, reducing start-up time and improving ramp rate.



### Emissions

**Is your plant prepared to increase returns within emissions regulations?**

Power plants that rely on fossil fuels to generate electricity will play a significant role in producing the world's electricity long into the future. For example, coal-based power is expected to contribute 30% of the world's electricity through 2025. Changing regulations and developing emissions standards have created the need for active management of emissions levels. GE Digital understands how to navigate evolving conditions and deliver digital solutions to help your plant comply with stringent emissions regulations, or reduce reagent consumption as required at the backend equipment.

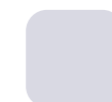
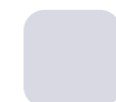

# Our Digital Products for Steam

## Plant Efficiency Advisor

The Plant Efficiency Advisor supports plant operation, through additional information for decision support like Key Performance Indicators and Scorecards. Moreover, it continuously calculates the overall plant level and at the individual equipment component level thermodynamic performance. Finally, it facilitates the evaluation of performance deviations and their subsequent correction/ mitigation via direct tool recommendations.

This capability leverages GE's internal plant thermal performance tool, which is used during initial design of the plant and its components. Once the overall actual plant heat balance is calculated ("as-is") through data reconciliation of the imported operational data, the plant "as-should" performances are calculated using the design heat balance tool. Based on the comparison of the two, the capability monitors and identifies the performance gaps of the components in the plant. The performance tool calculates "what-if" scenarios to act as a simulator, validating assumptions and testing scenarios with different operational input parameters and component configurations.

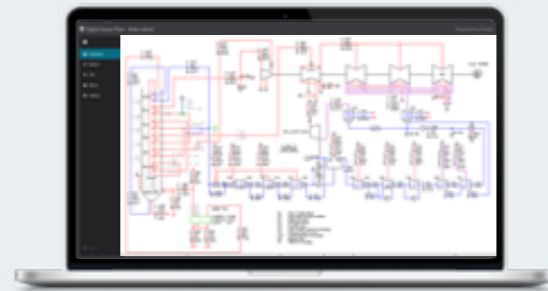

## Fuel Management Advisor

The Fuel Management Advisor provides recommendations to the operator based on advanced analytics that combine inputs from the DCS, operations of the plant, and additional feedback from an added online measurement of the coal ultimate, proximate and ash analysis before it enters the mill. This capability processes the results in real-time, providing early warning to relevant features in the case of:

- Coal quality change
- Continuous boiler control parameters adjustment
- Efficiency enhancement by optimizing auxiliary power operation
- Adapting exhaust temperatures to actual sulphur concentration
- Predicting primary NOx emissions

More generally the fuel management advisor helps decrease fuel consumption with increase of efficiency, decreased emissions, and increased availability and reliability of the boiler.



## Mill Optimization

The Mill Optimization is a digital application for coal mills that consists of a combination of mill process calculations, algorithms, inputs from the DCS system, and signals from new installed sensors (i.e. moisture sensor, vibration sensor), and coal properties sensor (i.e. fuel analyzer from the Fuel Management Advisor). This capability adjusts mill and firing system operations dynamically to best process parameters for gas flow, pulverized fuel fineness, primary NOx, etc. and adapts operational setpoints for variable loads and coal quality. This solution leverages all inputs and engineering first principles-based algorithms to optimize air flow, air temperature, grinding pressure and classifier adjustment.



## BoilerOpt: Combustion Optimization

The Combustion Optimization leverages advanced optimization technologies, such as neural networks and Model Predictive Control (MPC), to learn complex process relationships, dynamically determine the optimal fuel and air set points for the unit's goals and constraints, and direct the control system to make the necessary adjustments in real-time. This solution runs in closed-loop mode on a 24/7 basis and continuously adjusts the bias and trim settings that affect combustion performance. This results in increased boiler efficiency, reduced NOx emissions, and better control over steam temperatures, CO, LOI (Loss of Ignition), and opacity.

## BoilerOpt: Soot Cleaning Optimization

The Soot Cleaning Optimization is a soot blowing optimization software solution that determines the effect of soot blowing activity on heat transfer throughout the furnace and back pass and circumvents the negative availability and efficiency impacts of boiler over- and under-cleaning. Using expert rules and neural networks, the Soot Cleaning Optimization balances boiler cleaning actions to reduce boiler tube erosion and excessive thermal shocking, while improving steam temperatures and sprays and minimizing fouling, plugging and slagging events. It works in conjunction with existing soot blowing controls to drive closed-loop optimization.

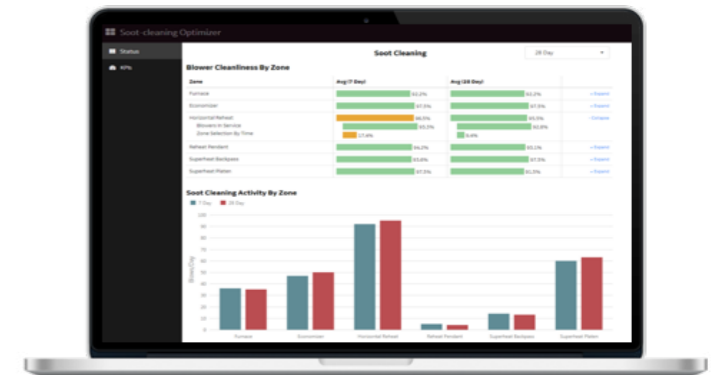

## Digital Boiler+

Digital Boiler + introduces a suite of sensors, boiler hardware upgrades, advanced controls strategy, and analytics to provide two plant operating modes: Low Excess Air mode for heat rate improvement and Low Load Stability mode.

The Low Excess Air mode uses improved digital sensors located at each coal burner to provide finer control on where air is injected. With improved air distribution in the Main Burner Zone, overall excess air can be minimized while maintaining NO<sub>x</sub> and CO emissions under control. Lower excess air improves boiler efficiency, reduces auxiliary power consumption, and decreases overall emissions.

In Low Load Stability mode, Digital Boiler + eliminates combustion imbalances to ensure the stability of the flame during low load operation.

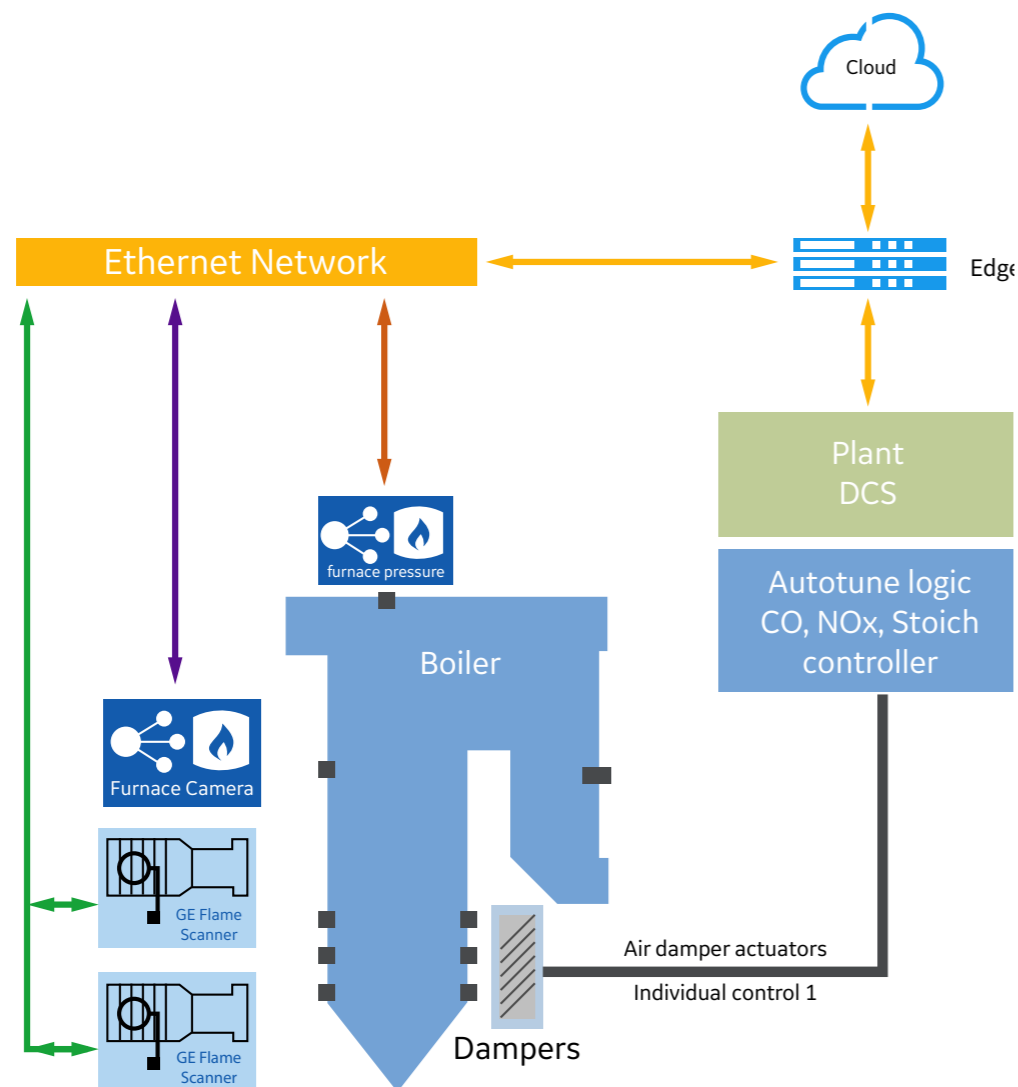

## Boiler Health Monitor For Thick-Wall Components

Boiler Health Monitor for thick-wall components is a solution that provides the true health and lifetime of thick wall components such as headers, drums, circulating pumps, etc.). This solution can be leveraged for evaluating effects of normal operation, rapid startups, load changes and cyclic operations and the impact on the lifetime of the pressure parts and creep stressed piping systems. The lifetime monitor system for thick walled components consists of:

- Thermocouples placed in critical locations on pressure parts to support creep and fatigue calculations, and alert on localized high-fatigue conditions due to flooding or overspray
- Key DCS operating data (i.e. pressures, temperatures, and steam flows) supports creep and fatigue calculations
- Analytics based on industry standards: EN 12952-4 for Creep, fatigue, and lifetime assessment calculations with enhancements based on GE boiler OEM knowledge and experience

## ESP Advisor

The ESP Advisor is a set of advanced analytics that provide further enhancement to the ESP (Electrostatic Precipitator) System and existing controls, through the continual monitoring of operations and the overall health of the major mechanical and electrical components of the ESP: (Rapping System, Gas Flow Distribution, High Voltage switchgear). These analytics will deliver improvements in availability. Following the actions of the ESP advisor can help in delaying the maintenance cycle (so that necessary spares can be procured in advance) and generate alarm conditions by identifying potential issues.

The main equipment issues tracked consist of the Rapping System (CE & DE), collecting plates, discharge electrode misalignment or breakage, contaminated insulators or baffle plate failure that cause clogging in the gas path. The carrying out of such health checks contribute to the avoidance of sparking/arcing, high opacity and particulate excursions and ESP unavailability.

## NID Advisor for Dry Flue Gas Desulfurization (DFGD)

The NID Advisor takes measurements and performs analytics to identify whether the NID (Novel Integrated Desulfurization) process is operating in an abnormal condition and provides advice on the identification of potential issues and their mitigation. Therefore, the NID advisor ensures that the process is meeting regulations while optimizing lime consumption. This algorithm monitors the overall health of the NID and suggests actions towards delaying the maintenance cycle (so that necessary spares can be procured in advance) or generate an alarm to avoid any major component failures inside the NID.

The principle is to propose potential failures that may cause abnormal response in data from the equipment. For each of these potential failures, a set of actions are then proposed as a corrective/mitigative measure.

Can GE help  
me use heavy  
fuel oil with  
best-in-class  
technology?

YES.

The Saudi's state-owned Saline Water Conversion Corporation decided to build the third phase of Yanbu 3 with both power generation and seawater desalination in mind. The plant will be one of the country's first supercritical power plants to run on Heavy Fuel Oil. We provided the integrated Power Package (i.PP): an efficient, cost effective solution that enables plant contractors to take advantage from core GE technology, including boiler, steam turbine and generator and expertise in plant EPC, while keeping overall performance guaranties.

The plant will deliver **2.7GW and 550,000 m3 of desalinated water** per day.

**This is the Power of Yes.**

## ↕ ⌚ Rotor Stress Controller

This capability monitors and controls the thermal stress within the steam turbine rotor to ensure safe and flexible operation. It leverages process measurements to calculate in real-time the present stress levels and takes necessary actions to operate the turbine as close as possible to the permissible stress limits. The key customer benefits are accelerated turbine start-ups and more robust transient operation due to improved controls, leading to better flexibility and reliability. The Rotor Stress Controller includes also a life time assessment indicator module, enabling the customer to make better trade-offs between turbine rotor life time and turbine operational flexibility, which makes it possible for the customer to make better trade-offs between life time and flexibility operation.

## ↕ ⌚ Turbine Lifetime Advisor

This capability is an advisory device that provides the customer with turbine lifetime related information for better asset performance management and more flexible operation. It records operation data such as startup time, lifetime consumption, process variables and control system parameters. It supports customer's decision-making process to optimize plant operation based on business needs and future maintenance planning. The Turbine Lifetime Advisor requires a turbine rotor stress controller, which is part of the steam turbine closed loop control function. The operation data will be stored on premise or in the cloud for further analysis.

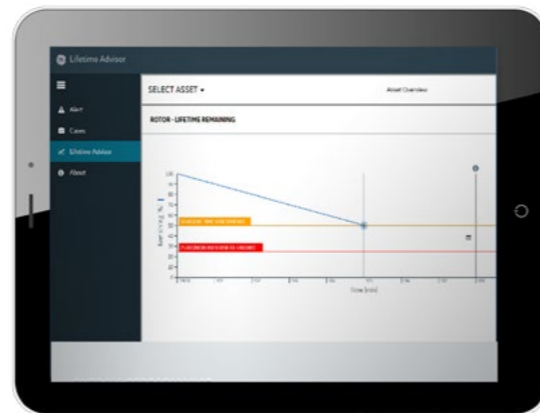

## ↕ ⌚ Turbine Startup Optimization

This capability acts as a superordinate control for turbine start-up and operation optimization including improved disturbance handling. It increases steam turbine availability, improves operational flexibility and reduces fuel consumption. The Turbine Startup Optimization is based on a model predictive control concept and combines a feedback control with an online optimization consisting of a transient digital twin with a detailed rotor stress model to predict future evolution based on past and current measurements. The key customer values include flexible and faster start-up strategies, reduced start-up time without compromising turbine lifetime, robust transient operations, and adaptable optimization based on customer specific objectives, constraints and limitations of the plant.

## ⌚ Turbine Torsional Vibration Advisor

The growing share of renewable and distributed power generation increases the risk of electrical network instabilities. Disturbances of the grid can cause fluctuations in the generator rotor torque of large power generation units, resulting in vibration of the shaft line and causing possible damage to the shaft line components.

The Turbine Torsional Vibration Advisor is a GE digital solution for model-based torsional vibration monitoring and diagnostics. The system offers the health monitoring of the power shaft line for better outage planning. The advisor enables real-time insight into stresses and vibration amplitudes at all critical locations along the rotor, for example, couplings, blades, and retaining rings of turbo-generators. It combines a state-of-the-art signal processing technology with a rotor dynamic digital twin to improve prediction accuracy.

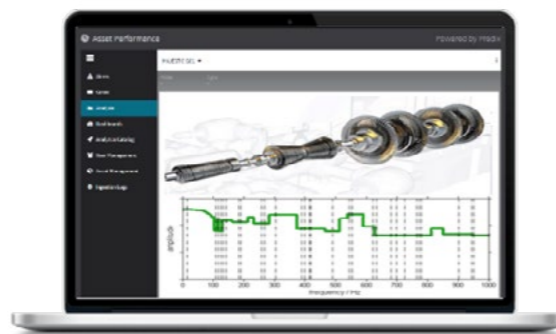

## ⌚ Valve and Actuator Monitoring System

The increasing availability of renewable energy sources has caused changes in power plant operation regimes. The steam turbine valves are now continuously controlled, whereas formerly they used to be either fully open or closed.

This capability includes required hardware and software to monitor the behavior of steam turbine valves. It provides assessment functionalities to determine valve performance and health. It improves the valve reliability and availability by visualization and advices. It helps the customer to minimize valve failures, improve maintenance planning, extend maintenance intervals, and reduce valve testing requirements



## ⌚ Generator Health Monitoring (GHM)

The Generator Health Monitor is a modular online monitoring suite available for any type of Generator that allows continuous monitoring and assessment to identify evolving issues related to:

- Stator bar insulation
- Rotor interturn insulation
- Bearing insulation and electro-erosion
- Stator end winding support tightness
- Water-cooled stator bar cooling efficiency
- Rush gear sparking and Hydrogen into water leakages for water-cooled stator bars.

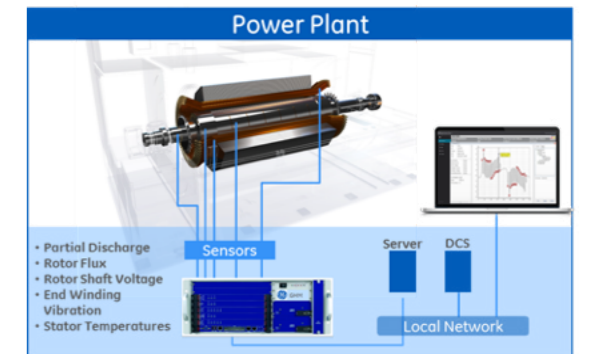

This facilitates improved outage planning, increasing availability and reliability while reducing maintenance costs.

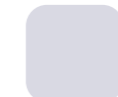
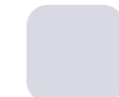



# Cyber Services

**Cyberattack and security breaches can quickly cascade into serious financial damage or impact on human safety.**

GE Power Automation & Control Cyber Services help keep installations up-to-date, recover from unplanned events faster, evaluate system security, and provide updates to prevent against external and internal threats.

These services ensure that your hardware is protected, that your system's firewall, antivirus, and patches are up-to-date, and that through a highly-secured remote access connection our trained professionals are able to access and maintain your control and intrusion detection systems.

Each of these services is performed in a secure environment, protecting your critical installations and systems, by our dedicated team specially trained and sensitized on cyber security regulations and standards.

# Cyber Services

CYBER SECURITY SERVICES

**GE's expertise in operational technology cyber security can help power companies and utilities plan, design, and build operational resilience into people, processes, and technology.**

**GE cyber security strategy is adapted to customer needs, divided into three stages:**

## STAGE 1 - ASSESS

Identify immediate security issues that can impact operations, even if the environment is thought to be air-gapped.

### Cyber Security Health Check

A first-level risk assessment aimed at identifying the most relevant area of improvement. Thanks to this assessment, it is possible to prioritize a smaller number of actions with high pay-off results.

### Cyber Security Site Assessment

In-depth, comprehensive evaluation of an operational site facility, based on industry standards and best practices, resulting in an individualized report with prioritized mitigation recommendations and strategies.

### Regulations compliance

- NERC CIP Cyber Vulnerability Assessment
- IEC Security Practices Certification
- IEC 62443 GAP Assessment

## STAGE 2 - PROTECT

Implement security monitoring and defensive layers to comply with standards and strengthen the security posture of a company.

### Basic Cyber Package

This offering provides a first line of protection for existing equipment/technologies to reduce attack surface and deploy the best solution with minimal system impact.

### Key benefits:

Improve security with cost-effective solution and little or no system downtime; fast deployment of cyber defense solutions and compliance to regulations for critical infrastructure.

### Advance Cyber Package

This package provides an in-depth knowledge of existing cyber security environment and detailed risk assessment of the plant to prevent intrusions and failures.

### Key benefits:

Gain awareness of plant status concerning cyber security and strengthen plant security and responsiveness against threats

## STAGE 3 - PREVENT

For the industrial layers of an organization, pursue proactive and predictive security measures such as having a response plan and trained personnel to execute it during or after cyber events.

## CONSULTING CYBER SERVICES & CYBER SECURITY TRAINING

To help to coordinate cross-functional relations (including OT & IT) and to develop cyber security awareness, we provide a comprehensive portfolio of security training courses on integration of cyber security and compliance to National/International regulations. Training content is developed and delivered by GE's security experts to increase staff knowledge and awareness of the cyber world.

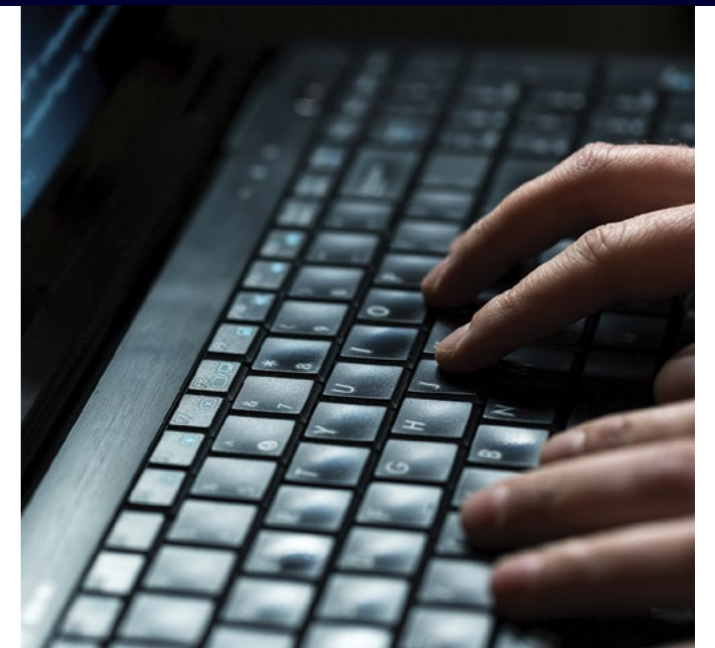

| Basic Cyber Package                  |
|--------------------------------------|
| • Health Check                       |
| • ALSPA Patch Management             |
| • Port Disabling & Station Hardening |
| • Network Hardening                  |
| • Security Logs Collector            |
| • Asset Content Monitoring           |
| • Secure Remote Access               |

| Advanced Cyber Package                |
|---------------------------------------|
| • Site Assessment                     |
| • Security Server                     |
| • Back up & Restore                   |
| • HMI Upgrade                         |
| • Intrusion Detection System          |
| • Secured Overall External Connection |

| Cyber Consulting Services   |
|---|
| • Audits  |
| • Cyber Security Training/Awareness                                       |
| • Support on National/International Regulations (ANSI in EU, NERC in USA) |
| • Incident Response (Disaster Recovery Plan)                              |

## Back-up & Restore

Available on every Windows technology-based system, the Back-up & Restore service provides secure maintenance and operation, reducing the time needed to restart equipment or the system after a crash or other unplanned event.

### KEY BENEFITS

- Stock Historian archives or other configurations
- First point for a fast disaster recovery plant
- Securely back-up data to an external data center
- Both full or partial back-up functions available
- Back-up periodically and when requested by the customer
- Restore from NAS or data center to DCS
- Easy retrieval from host servers for fast disaster recovery
- Easy to return to previous release of the DCS or Controcad database

## Patch Management

The Patch Management service improves your system's life cycle and increases plant availability while complying with cyber security regulations. We provide periodic software updates to our customers via secure remote access or by mailing a CD/DVD. This service includes operating system, antivirus, and ALSPA software updates.

### AVAILABLE PACKAGES:

- Security patches for Windows 7 or Windows 10
- Signature and engine of antivirus
- Antivirus update
- ALSPA patches: HMI, CCAD, MFC3000/CE3000

### KEY BENEFITS

- Performed in a secure environment
- Access to current software upgrade programs
- Easier maintainability
- Ability to bundle System Update with Remote Access for installation improvement

# BOILERS

GE boilers offer the widest portfolio of custom-made boilers in the industry for all fuels. Our unique design and sizing capabilities build on 100+ year of experience for efficient and clean combustion with enhanced flexibility and reliability over the lifetime of the asset.

GE's Boilers portfolio addresses all fuels with PC boilers that can burn a wide range of hard coals, lignite, and oil/gas, and CFB for both conventional and difficult to burn fuels.

GE's technologies ensure optimal fuel preparation, clean and efficient combustion with high reliability and flexibility. Our experienced -based design enables the burning of a wide fuel range, while avoiding or mitigating the impact of slagging, fouling, corrosion and erosion in the furnace. This results in enhanced availability for our customers with boiler reliability as high as **94%**.

## Extensive fuel experience

### Project experience

|                                |  |   |  |                                |                              |
|--------------------------------|--|---|--|--------------------------------|------------------------------|
| Fiddlers Ferry<br>Drax<br>Amer | Neurath F/G<br>Belchatow II<br>Sostanj 6<br>Levice 5<br>Niederaussem K<br>Mae Moh 4-13 | Manjung 1-4<br>Comanche 3<br>RDK 8<br>Westfalen D/E<br>Barh II<br>Waigaoqiao II & III | Yanbu 3<br>Shoaiba I, II & III<br>Ravenswood 3<br>Pittsburgh 7<br>LaSpezia 4 | Baima<br>Luohuang 1-4<br>Narva | Tamuin I & II<br>Mailiao 1-2 |
|--------------------------------|--|---|--|--------------------------------|------------------------------|

### Fuels

|  |         |                              |           |                         |                           |
|--|---------|------------------------------|-----------|-------------------------|---------------------------|
| Biomass<br>Biomass Co-firing                 | Lignite | Bituminous<br>Sub-Bituminous | Oil       | Anthracite<br>Oil Shale | Petcoke                   |
| Circulating Fluidized Bed<br>Pulverised Coal |         | Pulverised Coal              | HFO / LFO |                         | Circulating Fluidized Bed |

## Increased efficiency

Unmatched design and fuel expertise ensures right-sized boilers for all fuels

30% of the world's coal installed base : 270 GW

## Evolutionary platform approach

Achieve higher availability and proven boiler reliability up to 94% to ensure maximum uptime

## High availability and reliability

Operate at best efficiency for reduced coal consumption and emissions

## Enhanced operational flexibility

Offer enhanced cycling flexibility for increased dispatch and ancillary services

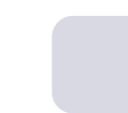
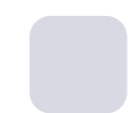
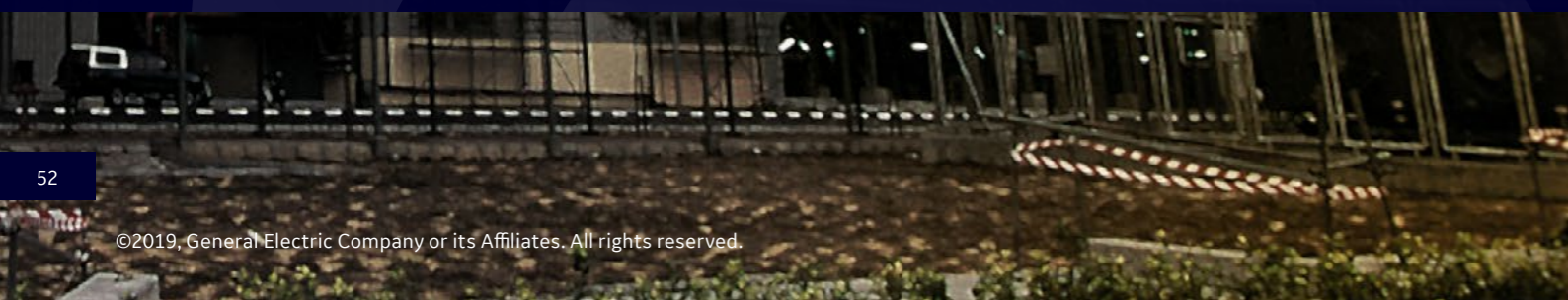

# Fuel capability

Our knowledge of fuel and combustion, a core GE competence, is derived from 100+ years in the industry. We have extensive field experience gathered through over 270 GW of installed boiler capacity - more than 30% of the installed base.

GE's mastery of coal milling, firing systems and boiler arrangements for all types of coal and other fuels enables to maximize carbon burnout. This field experience, combined with our extensive laboratory expertise, is built into our design standards to ensure we offer high performing, reliable boilers based on an outstanding coal data base covering the features of almost all global coals. We also use state of the art modelling and analytics capabilities to define optimal furnace arrangements. We are ensuring our boilers are right-sized, optimizing performance, flexibility and cost effectiveness.

## Our experience for a given fuel basket

Lignite example data:

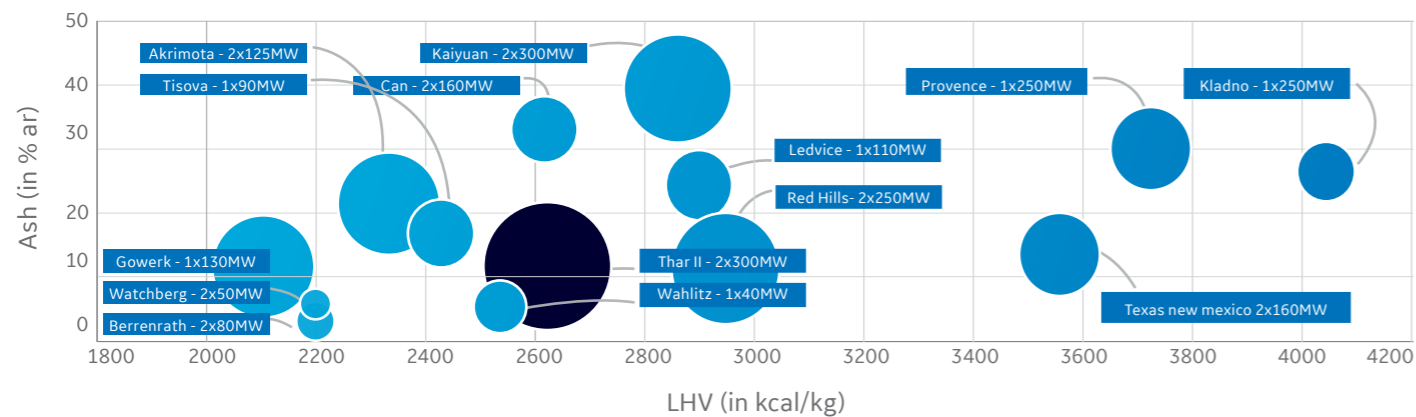
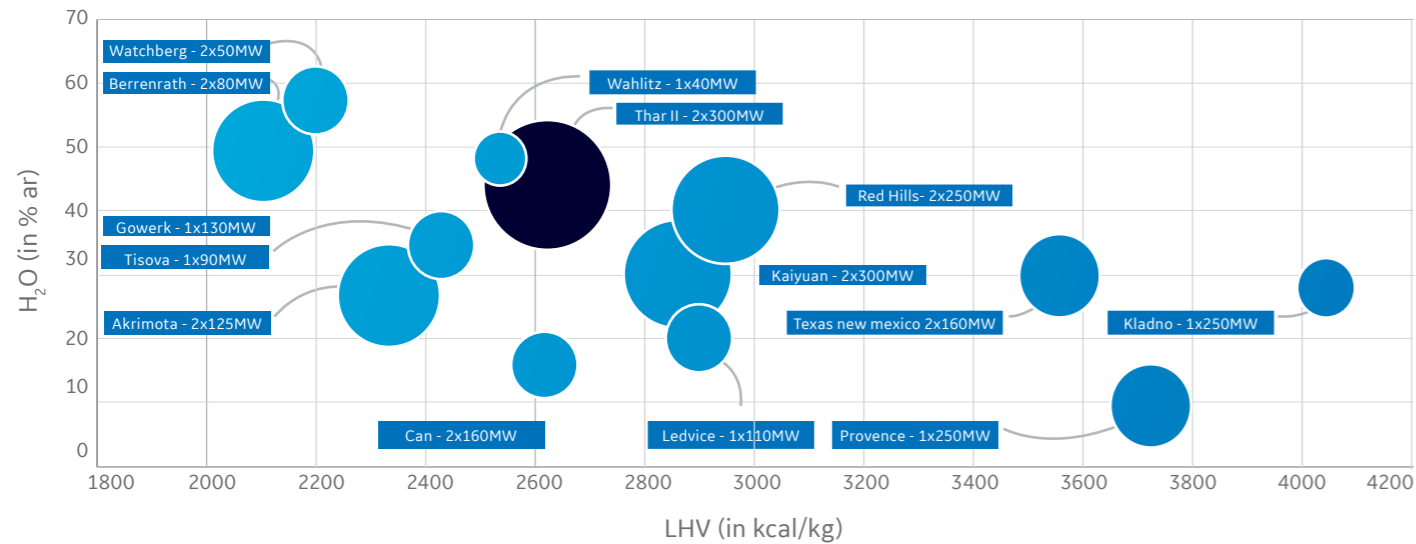

GE has a full range of boiler offerings, from boiler to complete boiler island configurations, depending on our customers' specific project needs.

|             | PC                  | CFB |
|-------------|---------------------|-----|
| Coal        | Lignite B           | ●   |
|             | Lignite A           | ●   |
|             | Subbit. C           | ●   |
|             | Subbit. B           | ●   |
|             | Subbit. A           | ●   |
|             | Bit. high vol. C    | ●   |
|             | Bit. high vol. B    | ●   |
|             | Bit. high vol. A    | ●   |
|             | Bit. med. vol.      | ●   |
|             | Bit. low vol.       | ●   |
|             | Semi-anthracite     | ●   |
|             | Anthracite          | ●   |
| Oil         | Heavy fuel oil      | ●   |
|             | Vacuum residual oil | ●   |
|             | Crude oil           | ●   |
| Gas         | Natural gas         | ●   |
|             | Coke oven gas       | ●   |
|             | Blast furnace gas   | ●   |
| Oppty. Fuel | Biomass             | ●   |
|             | Oil shale           | ●   |
|             | Petcoke             | ★   |
|             | Waste coal          | ●   |

★ Co-firing in limited amounts

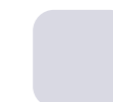
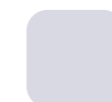

## Boiler arrangements for different fuels enabling advanced steam cycles

GE has pioneered the introduction of supercritical steam generation technology with over 116GW of SC and USC installed base worldwide. It continues to drive technologies towards high efficiency ultra-supercritical steam parameters. Our expertise in thermal, hydraulic and material sciences has led to boiler designs that contribute to cycle efficiency of 44 to 48% on an LHV basis, significantly reducing both fuel and emission control costs for our customers.

For pulverized coal technologies, GE has offered both two-pass and tower designs in single and double reheat configuration for over 50 years. The latest generation of A-USC design supports steam pressure of 330 bar and temperature at reheat turbine inlet up to 670°C generating a net plant efficiency of 1.6 % compared to the most advanced installed plant.

Our boilers are designed for the optimal size to balance capital expenditure versus auxiliary consumption and pressure drop.

GE provides the highest thermal efficiency at performance tests, in operation, and over load range. Building on its USC experience in pulverized coal boilers, and expertise in designing Circulating Fluidized Bed boilers, GE has introduced highly efficient ultra-supercritical CFB technology, suited for difficult fuels such as lignite up to 660 MW and up to 900 MW for hard coal, thanks to our modular design.

## GE's pulverised coal (PC) boilers are generating steam for today's large scale global power projects with up to 1350MW electrical output for coal units at pressures and temperatures that enable Net Plant Efficiencies of up to 49.1%

Our two pass and tower boilers can reach up to 330 bar/ 650°C /670°C in single reheat configuration, and 330 bar /650°C /670° C /670° C in double reheat configuration.

In the 2-pass configuration, radiant pendant surfaces are located above the furnace, and convective surfaces are arranged horizontally in the second pass, enabling reduced height of the furnace and simple element support structure. The two pass configuration is available with both spiral and vertical wall design.

The Tower configuration has been developed mostly for high moisture lignite. It eliminates change in direction of gas flow reducing erosion potential for more difficult to burn fuels. It offers specialized firing systems to burn all types of lignite. Tower boiler technology is integrated with an advanced beater wheel mill providing efficient operation and maintenance with high cycling flexibility.

For HFO, two pass and tower is available up to 1,000MW electrical in single reheat configuration with 270 bar/565°C /585°C .

## GE CFB technology

For low-grade and difficult-to-burn fuels such as anthracite, lignite, petroleum coke, oil shale, discarded coal and biomass, GE offers Circulating Fluidized Bed technologies with different arrangements suited to fuel .

GE CFB technology has low inherent NOx emissions at 50-200 mg/Nm<sup>3</sup> due to the following features:

- Relatively low and uniform furnace temperatures of approximately 850°C to 900°C
- Air staging in the lower furnace through the introduction of primary air and secondary air at appropriate levels
- Uniformly distributed fuel and air due to intense mixing inside the bed of solids in the furnace
- Isothermal conditions in the circulating solid loop due to the positive impact of highly efficient cyclones

Additionally, low SO<sub>2</sub> emissions with 95 to 98% sulfur removal through:

- Injection of prepared and dried limestone in the furnace
- Potentially inherent capture by the fuel-bound calcium
- Dry scrubber NID achieving 98 % sulfur removal while reducing limestone consumption
- Just-In-Time (JIT) system for limestone drying and crushing available for direct limestone feeding

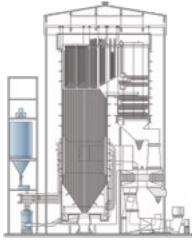
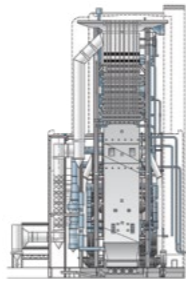
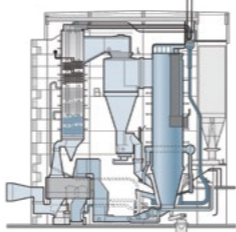
| Pulverised Coal  |  | CFB boiler   |
|--|--|--|
| Two-pass boiler  | Tower boiler   |  |
|   |   |                                 |
| Bituminous, sub-bituminous<br>Lignite A<br>Oil and gas                               | Bituminous, sub-bituminous<br>Lignite A and B  | Anthracite through lignite A and B<br><br>Opportunity fuels:<br>petroleum coke, biomass, waste coal, oil shale, etc. |
| Up to 1,350 MWe<br>Up to 330 bar / 650°C / 670°C<br>DRH 330 bar / 650°C /670°C/670°C | Up to 1,350 MWe<br>Up to 330 bar / 650°C / 670°C<br>DRH 330 bar / 650°C /670°C/670°C | Up to 660 MWe for lignite, higher for hard coal<br><br>Up to 300 bar / 600°C / 620°C                                 |

Typical fuels

Capacity

## State-of-the-art combustion and steam generation

At GE, we have developed over time the most advanced firing techniques with efficient fuel distribution and air staging. This allows controlled and uniform combustion for low emissions and minimal carbon losses. For pulverized coal boilers, GE first introduced tangential firing in 1927. Fuel and air are injected through windboxes from the corners of the furnace, aimed tangential to an imaginary circle at the center of the furnace. This creates a single rotating flame envelope (vortex) that produces a uniform and consistent heat profile across the furnace walls. GE has continuously upgraded its technologies with concentric firing systems and tilting burners, enabling high efficiency combustion over the operating load range. GE staging techniques and overfire air arrangements minimize the availability of oxygen during the critical early phases of combustion and enable flame stability.

GE offers optimized combustion for low primary NOx to reduce or eliminate need for secondary NOx removal while maintaining minimum NOx emission (<100\* mg/Nm3)

Our advanced combustion technologies and high cycle efficiency also reduce fly ash hence lowering disposal cost. Overall reduced emissions from primary control and higher cycle efficiency lead to lower reagent use in air quality control systems (OPEX savings)

## Operational flexibility

As businesses seek ways to decrease costs while maintaining or growing revenue, boilers must remain flexible and be able to react quickly to changing conditions with the increased penetration of renewable power generation. Traditional fossil plants must be ready to operate safely through transient mode and be able to provide additional reserve margin for enhanced grid stability.

GE boilers achieve this thanks to specific flexible operations features such as enhanced temperature control, sliding pressure capability and our dynamic classifiers. Our pulverized coal boilers currently allow for ramp rate as fast as 6% per minute and down to 20% for hard coal and 35% for lignite based on BMCR.

For customers using imported coal, or looking at diversified coal supplies, our boiler designs offer extensive fuel firing flexibility for customers to be able to burn safely and reliably a large variety of coal.

These features enable:

- Clean and efficient combustion facilitating low primary NOx formation resulting in less SCR catalyst and less reagent consumption
- Lower maintenance costs and less frequent outages

## Coal Mills

Licenses for our milling technology can be found in all coal-powered regions of the world. Pulverizing solid fuel to powder enables fuel drying and transportation for combustion.

Fine grinding increases the fuel exposed surface area while simultaneously drying and controlling its distribution. These are integral steps to efficient, low emission combustion which is optimized in combination with boiler thermal performance.

We design and continuously develop a complete range of milling technologies that include vertical spindle bowl mills and beater wheel mills, with classifier options to match our customers' efficiency and fuel flexibility demands. Our mill and classifier portfolio can process all fuel blends commonly used for power generation, while maintaining excellent combustion efficiency under low emissions conditions with reduced power consumption and maintenance requirements. Our mills have the ability to handle all solid fuels and fuel blends suitable for power generation; from anthracite to lignite B.

Our mills have a modular design adaptable to fuels and capacity needs, and offer a unique construction concept that allow mill installation without welding, enabling increased quality and less construction costs. Our interchangeable modular components also reduce inventory cost and minimize outage frequency and duration.



Bowl mills - HP Type



Bowl mills - SM Type



Beater wheel mills - Type S, V, SV

|                             |  |  |   |
|-----------------------------|--|--|---|
| <b>Capacity range (t/h)</b> | 18 to 170                              | 12 to 170  | 44 to 170                                 |
| <b>Classifier</b>           | Static or Dynamic                      | Static, Dynamic & Combined   | Box Type (Static)                         |
| <b>Loading</b>              | Spring (Hydraulic Option)              | Hydraulic (Spring Option)  | Speed Control for Operational Flexibility |
| <b>Coal</b>                 | Bituminous/Sub-Bituminous<br>Lignite A | Bituminous/sub-bituminous<br>Lignite A<br>Anthracite<br>Petroleum coke | Bituminous/Sub-Bituminous<br>Lignite A    |

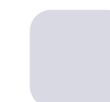
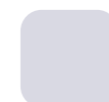

PORTFOLIO AND OVERVIEW

# STEAM TURBINES

GE's steam turbine platform offers a broad product portfolio that accommodates a wide range of site conditions, operational needs, advanced steam cycles, and applications. In fossil-fired steam plants, our steam turbines offer class-leading ultra-supercritical steam parameters

## A world leader in the development and application of steam turbine technology

GE has supplied more than 30% of the world's installed steam turbine capacity, totaling more than 1000 GW of installed fleet. For more than a century, we have consolidated the best available technology from numerous suppliers into a single platform that supports our advanced, innovative, efficient and reliable turbine solutions.

|  |              |  |          |
|--|--------------|--|----------|
| REHEAT<br>330bar (4786psi)<br>650°C(1200°F)<br>670°C (1238°F)                          | GE STF-D1250 |  | >54.0% ^ |
| DOUBLE REHEAT<br>330bar (4786psi)<br>620°C(1150°F)<br>630°C (1166°F)<br>630°C (1166°F) | GE STF-D1250 |  | >53.0% ^ |
| REHEAT<br>300bar (4786psi)<br>585°C (1112°F)<br>620°C (1150°F)                         | GE STF-D1050 |  | 51.0% ^  |
| REHEAT<br>300bar (4350psi)<br>600°C (1112°F)<br>600°C (1112°F)                         | GE STF-A1050 |  | 50.0% ^  |
| REHEAT<br>245bar (3553psi)<br>565°C (1050°F)<br>565°C (1050°F)                         | GE STF-D850  |  | 49.0% ^  |
| REHEAT<br>245bar (3553psi)<br>565°C (1050°F)<br>565°C (1050°F)                         | GE STF-A850  |  | 47.8% ^  |
| REHEAT<br>190bar (2756psi)<br>565°C (1050°F)<br>565°C (1050°F)                         | GE STF-D650  |  | 47.5% ^  |
| REHEAT<br>190bar (2756psi)<br>565°C (1050°F)<br>565°C (1050°F)                         | GE STF-A650  |  | 47.5% ^  |
| NON-REHEAT<br>140bar (2031psi)<br>565°C (1050°F)                                       | GE STF-D250  |  | 40.5% ^  |
| NON-REHEAT<br>140bar (2031psi)<br>565°C (1050°F)                                       | GE STF-A200  |  | 40.5% ^  |

^ Up to % Steam Turbine efficiency

### Increased efficiency

Continuous improvements to the water steam cycle are supported by our broad rear stage portfolio. Our advanced 3D blading platform helps enhance the load grade and customize the flow path for project specific conditions and increased performance.

### Evolutionary platform approach

The application of proven design principles to all module types and sizes helps achieve higher reliability. Operational feedback is systematically applied across GE's entire modular turbine product portfolio to enhance customer value.

### High availability and reliability

Advanced lifetime assessment procedures reduce maintenance and increase turbine availability. Our long-term testing program validates material behaviour to help ensure high reliability of our steam turbine components.

### Enhanced operational flexibility

Advanced fracture mechanic methods provide reliable lifetime assessment of the steam turbine components and increased cycling capabilities. An enhanced blade groove design reduces thermal stresses for increased rotor life.

## Welded rotors

Introduced in 1930, our welded rotor technology has stood the test of time with no ruptures reported in our large diameter rotors – manufactured by welding together separate smaller forgings. This beneficial design allows for:

- Appropriate forging material selection, based on temperature level at each section of the turbine
- Stress reduction during thermal transients for faster and more frequent load cycling capability
- Better access for ultra-sonic testing equipment – translating to higher reliability

## Shrink ring design

Our shrink ring design allows for a rotationally symmetric inner casing resulting in:

- Reduced distortions while clearances are maintained during operation – providing sustained higher efficiency
- A more compact design with smaller wall thicknesses for flexible load cycling and faster startup times translating to higher reliability

## Advanced blading

Innovative blading technology is apparent in our:

- Modern, three-dimensional profile design that results in higher efficiency
- High pressure (HP), intermediate pressure (IP), and low pressure (LP) front stage blades that are milled from a single forging for excellent mechanical integrity and higher reliability

## LP Large last stage blades

Our enhanced last stage blade portfolio offers:

- Dense staggered last stage blade sizes for project-specific cold-end conditions and increased efficiency
- A robust design with stress-enhanced grooves and blade attachments for higher reliability

## Single bearing design

Our multi-casing turbines have a single bearing between each turbine section for:

- Avoidance of load shifting for higher reliability
- Efficient shaft alignment for reduced construction time
- Shorter overall turbine shaft length for lower building costs

### Blade size for 50 Hz and 60 Hz

|                  |                  |                  |                  |                  |                  |                  |
|------------------|------------------|------------------|------------------|------------------|------------------|------------------|
| <b>50 Hz</b>     | 27"              | 33"              | 37"              | 41"              | 48"              | -                |
| <b>60 Hz</b>     | -                | -                | 30"              | 34"              | 40"              | 50"              |
| <b>Design</b>    | Single Connected | Single Connected | Single Connected | Single Connected | Double Connected | Double Connected |
| <b>Materials</b> | 12% Cr Steel     | 12% Cr Steel     | 12% Cr Steel     | 12% Cr Steel     | PH Steel         | Titanium         |

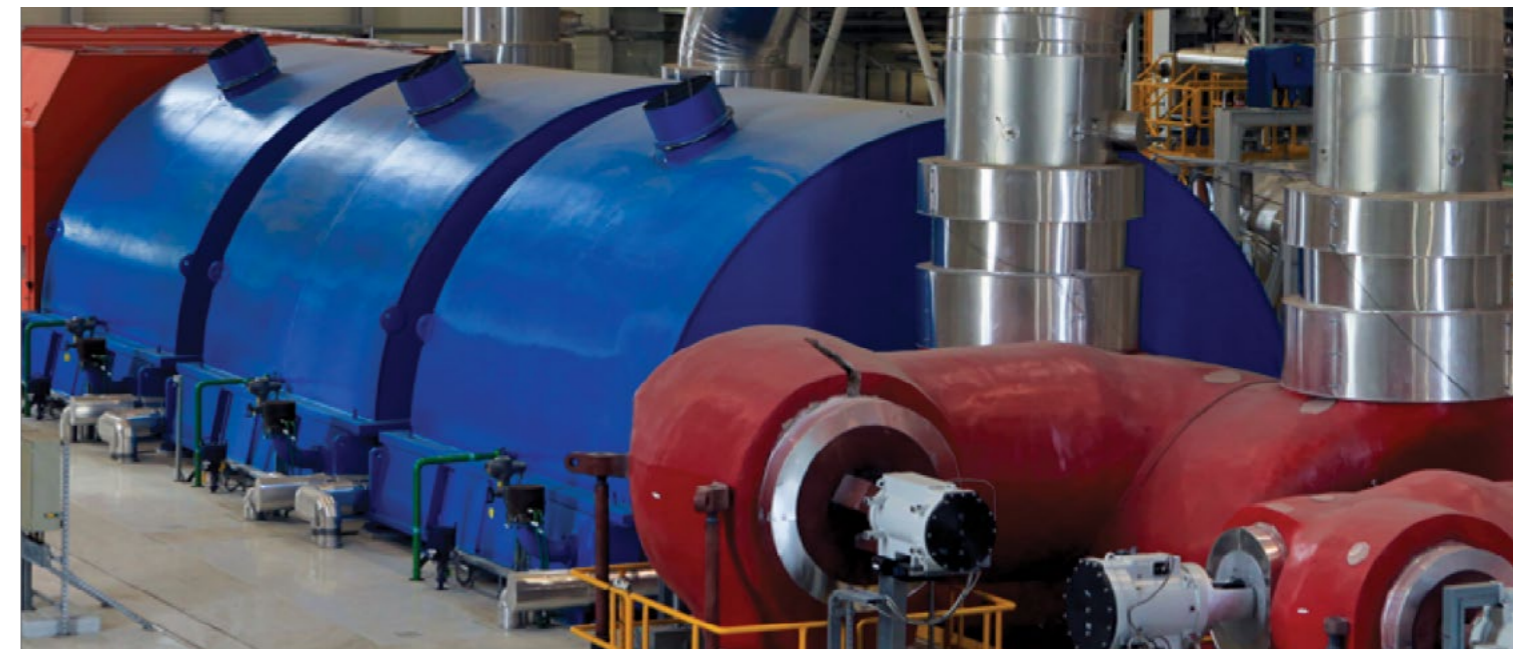

## GE STF-D1050, STF-D850, STF-D650 and Steam Turbines

### Designed for efficiency and reliability

GE's D-Series is a modular product platform for single and double reheat utility steam turbines in the 100 to 1,200 MW power output range. Our modular concept governs all engineering and manufacturing processes, and results in reduced construction and commissioning times, higher reliability, and excellent efficiency. To enhance performance, the steam path is always adapted to the specific project requirements.

The extensive LP last stage blade portfolio for 50 Hz and 60 Hz models offers rear stage sizes from 30 inches up to 48 inches. The number and size of LP turbines can be tailored to specific site conditions. The STF D1050 steam turbine configuration can have up to six casings.

- The D-Series are designed for main inlet conditions up to 650°C (1200°F) and 330 bar (4786 psi) with reheat temperatures up to 670°C (1238°F).
- HP turbines can be equipped with a second main steam injection system by means of integrated overload valves. This method provides additional load reserve in cases of sudden steps in power demand.
- Startup valves (TAL) help ensure a safe and trip-free runback from full load to house load after load rejection.
- HP, IP and valve units are shipped fully assembled enabling shorter installation time on site. The LP turbine is dispatched in pre-assembled lots for easier handling and reduced construction time on site.
- Skid mounted lube and control oil systems with pre-assembled pumps, filters, valves, and interconnecting piping are available for all turbine sizes.
- Sleeved rotor couplings help ensure durable shaft alignment and smoother operation.

\* A proprietary steam turbine control & protection system to ensure safe and reliable operation and integration with wider plant control system scope  
 \*An IEC61508 compliant safety system

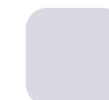
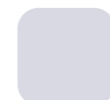





GE STF- D1050 DRH

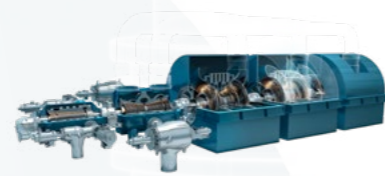

GE STF-D1050 SRH



GE STF-D850

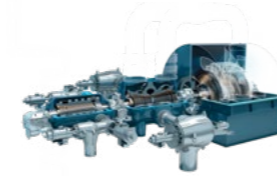

GE STF-D650

GE STF-D250

|                                 |   |   |   |  |   |
|---------------------------------|---|---|---|--|---|
| <b>Main steam</b>               | 330bar (4786psi)<br>620°C (1184°F)                                  | 330bar (4786psi)<br>650°C (1200°F)                                  | 245bar (3553psi)<br>585°C (1085°F)                                  | 190bar (2756psi)<br>565°C (1049°F)   | 140bar (2030psi)<br>565°C (1049°F)            |
| <b>Reheat temperature</b>       | 630°C (1166°F) RH1<br>630°C (1166°F) RH2                            | 670°C (1238°F)  | 585°C (1085°F)  | 565°C (1049°F)   | -   |
| <b>Frequency</b>                | 50 Hz   | 50 Hz and 60 Hz   | 50 Hz and 60 Hz   | 50 Hz and 60 Hz  | 50 Hz and 60 Hz                               |
| <b>Output</b>                   | ≤ 1100 MW   | ≤ 1200 MW   | ≤ 1000 MW   | ≤ 700 MW   | ≤ 300   |
| <b>Steam turbine efficiency</b> | Up to 54%   | Up to 54%   | Up to 49%   | Up to 47.5%  | Up to 40.5%                                   |
| <b>Maximum backpressure</b>     | 0.35 bar (10.34 inHg)<br>0.7 bar (20.67 inHg)                       | 0.35 bar (10.34 inHg)<br>0.7 bar (20.67 inHg)                       | 0.35 bar (10.34 inHg)<br>0.7 bar (20.67 inHg)                       | 0.35 bar (10.34 inHg)<br>0.7 bar (20.67 inHg)  | 0.35 bar (10.34 inHg)<br>0.7 bar (20.67 inHg) |
| <b>Control concept</b>          | Sliding pressure mode<br>Hybrid mode with or without overload valve | Sliding pressure mode<br>Hybrid mode with or without overload valve | Sliding pressure mode<br>Hybrid mode with or without overload valve | Sliding pressure mode<br>Fixed pressure mode<br>Hybrid mode with or without overload valve | Sliding pressure mode<br>Fixed pressure mode  |

The D-Series are designed for main inlet conditions up to 650°C (1200°F) and 330 bar (4786 psi) and reheat temperatures up to 670°C (1238°F).



## STF-A/D1050 Steam Turbine

### Platform with enhanced design flexibility

While USC cycles with 600°C/620°C have become the industrial standard for larger utility steam turbines, many of the smaller size steam plants below 400MW output are still designed and operated with subcritical water steam cycles using 540°C/540°C.

By downsizing the well proven modular USC platform advanced steam cycles can now be used with steam turbines from 1200MW down to 150MW output. The STF-A/D1050 platform extension can be tailored to meet our customer specific project requirements in a double (A) and triple (D) casing arrangement.

A1050 Turbines with a rear stage size up to 34"/41" are completely shop assembled and shipped to site to reduce construction time.

By downsizing the well proven USC technology to steam turbines designed for 150 to 400MW output the efficiency can be increased by more than 3% pts reducing the heat rate by more than 6%.

The reuse of the well proven USC technology and materials embedded in standardized casing sections results in high reliability of the STF-A/D1050 platform.

The STF platform can be tailored to meet our customers' specific project requirements.

### Designed for flexibility and optimized plant layouts

- The STF-A/D1050 is designed for main steam inlet conditions up to 600°C(1012°F)and 300bar (4350psi)
- Family of highly efficient last stage blades to accommodate to a large condenser pressure range typical for water and air cooled condensing plants
- Single (A1050) or double flow (D1050) LP turbines to meet the project specific back pressure conditions
- LP turbines with side-or axial steam exhaust supporting a low-level turbine arrangement to reduce civil cost

|                                 |                                      |
|---------------------------------|--------------------------------------|
| <b>Main steam</b>               | 300bar (4350 psi)<br>600°C (1112F)   |
| <b>Frequency</b>                | 50 Hz and 60 Hz                      |
| <b>Output</b>                   | 150 –400MW                           |
| <b>Steam turbine efficiency</b> | Up to 51.0%                          |
| <b>Maximum backpressure</b>     | 0.7 bar (20.67 inHg)                 |
| <b>Control concept</b>          | Sliding pressure mode<br>Hybrid mode |

Decades of experience have shaped GE's STF platform into an innovative selection of preengineered sections and modules that offer flexibility.

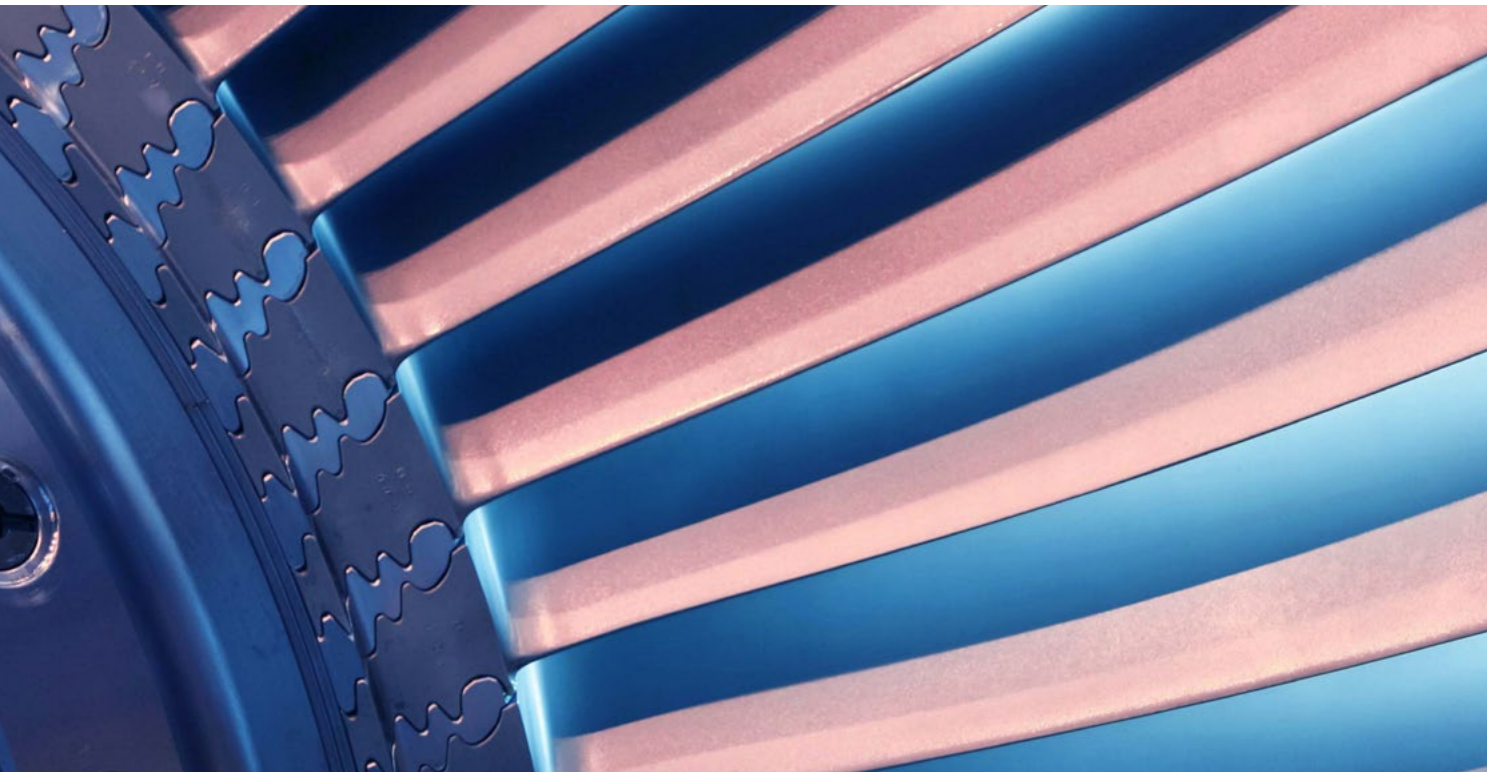

## STF-D1250 Steam Turbine

### Platform with enhanced design flexibility

While USC cycles with 600°C/620°C have become the industrial standard for large utility steam turbines, the technology and the materials for more advanced steam cycles have been further developed and are available now.

The well proven STF D-1050 platform has been extended to accommodate to steam conditions as high as 330bar/650°/670°. This increases significantly the steam cycle and turbine efficiency.

Due to GE's modular platform concept the required design and material changes are moderate and limited to the high-and medium pressure turbine and their associated valves. By reusing the well staggered low-pressure turbine family GE's platform can offer the most efficient rear stage option for any site condition.

The robust single reheat cycle combines highest efficiencies with flexible and dependable plant operation.

### Designed for efficiency and reliability

- The well proven STF-D1050 is now available for advanced main steam inlet conditions up to 650°C(1200°F) and 330bar(4786psi)
- Family of highly efficient last stage blades to accommodate to a large condenser pressure range in the 50Hz and 60Hz markets
- Single reheat cycle design for highest efficiencies and adequate operational flexibility.
- Consequent application of the single bearing concept to offer the most compact turbine-generator shaft line available in the market

|                                 |                                   |
|---------------------------------|-----------------------------------|
| <b>Main steam</b>               | 330bar (4786psi)<br>650°C (1200F) |
| <b>Frequency</b>                | 50 Hz and 60 Hz                   |
| <b>Output</b>                   | 800-1200MW                        |
| <b>Steam turbine efficiency</b> | Up to 55.0%                       |
| <b>Maximum backpressure</b>     | 0.7 bar (20.67 inHg)              |
| <b>Control concept</b>          | Sliding pressure mode             |

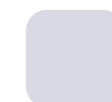
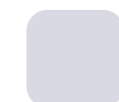

PORTFOLIO AND OVERVIEW

# GENERATORS

Designed for efficiency and reliability, enhancing operation and limiting maintenance cost.

## Enhanced technical performance and reduced maintenance costs

GE's generators are experienced and reliable machines that offer high technical performances. Our generators have successfully operated in more than 12,000 installations worldwide, providing different power output levels and cooling media depending on customer need. Designed to help lower plant investment costs, our generators enhance operation and limit maintenance costs.

### GEN-W: Water-Cooled (formerly GIGATOP 2-Pole)

Water-Cooled generators are GE's enhanced solution for coal power plant applications.

Over 680 GE water-cooled generators have been installed since their introduction in 1961. A power plant in the Netherlands has the world's most powerful generator (1,113 MW) running in a coal power plant.

### GEN-H: Hydrogen-Cooled (formerly TOPGAS)

Hydrogen-cooled generators are high-efficiency machines.

The high power output of this product family provides a cost-effective alternative to conventional water-cooled machines that are commonly used for similar high power output levels.

### GEN-A: Air-Cooled (formerly TOPAIR)

Precise and robust generators offering high power output and efficiency. This machine can be used in many different applications.

### GEN-A: Air-Cooled (formerly TOPACK)

Ideal generators for applications demanding simple, packaged and ready-to-install generators. There are more than 1,180 machines installed worldwide.

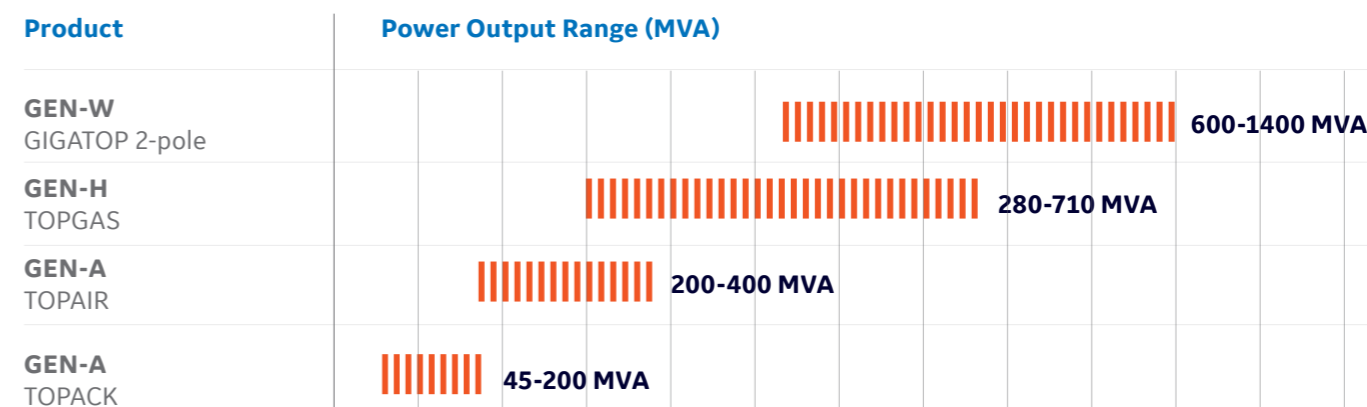

GE's generators are designed to meet all relevant standards, regulations and grid codes that may apply in specific 50 Hz and 60 Hz countries. Machines are designed according to IEC and IEEE standards and are designed for temperature rises of class 130 (B). The insulation, using either DURITENAX or MICADUR\* tape (depending on the product family), fulfills thermal class 155 (F). We perform quality tests and inspections during manufacturing, delivery, construction and commissioning of the machines to help ensure high quality and conformance with our customers' needs.

Can GE deliver  
my turnkey  
power plant  
on time and  
on budget?

# YES.

As the EPC contractor, GE successfully delivered Manjung 4, 1000 MW ultra supercritical plant in Malaysia, in **just four years** and within budget. We received **awards** from Asian Power and International Project Management Association for this project.

In addition to its incredible **efficiency 10% higher** than the global average, the plant has achieved extremely high availability, particularly during the second year of operation with a **97% availability** rate.

**This is the Power of Yes.**



## Technologies bring added value

GE's generators use technologies and contain features that save time and money for the end customer. Based on many years of proven experience and continuous feedback from our customers, these technologies often are shared among different product families, as shown in the following three examples.



### Tubes in stainless steel for stator-winding cooling

Used on GEN-W Water-Cooled generator

- The cooling tubes in the stator winding of GE's GEN-W Water-Cooled generator are made of stainless steel, so they can't corrode, and the risk of clogging leading to an unplanned forced outage is eliminated. GE is the only manufacturer to offer this feature.



### Self-retightening end-winding support

Used on GEN-A, GEN-W & GEN-H generators

- GE's generators have a self-retightening end-winding support, which allows thermal expansion of the bars while simultaneously tightening the winding in radial and tangential directions. This system saves maintenance time for the generator end user, avoids forced outages, and increases plant availability on the grid.

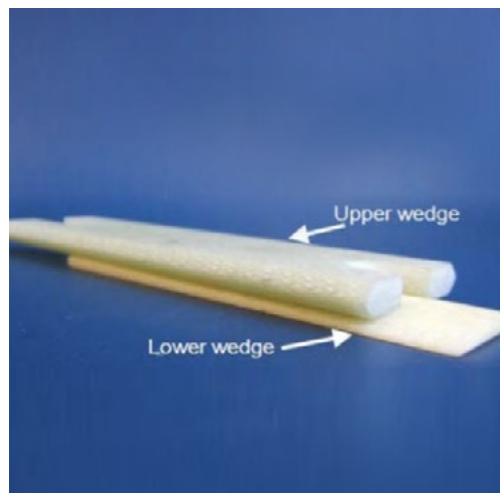

### Concave-Convex wedges

Used on GEN-A, GEN-W & GEN-H generators

- The concave-convex wedges used in GE's generators have a unique design that sustains pressure on the stator bars. This constant pressure prevents radial movements of the winding, avoiding a forced outage from insulation breakdown while cutting maintenance hours and increasing plant availability.

## GE's generators have additional design features that enhance technical performance and reduce maintenance costs:

- Roebel bars in the stator winding reduce losses and heighten efficiency.
- The MICADUR\* insulation system is a well-proven insulation tape that helps ensure high reliability.
- Laminated press-plates and low-loss core laminations enhance efficiency.

The following table summarizes the availability of some features within each product family:

|   | GEN-W                          | GEN-H                          | GEN-A       | GEN-A                 |
|---|--------------------------------|--------------------------------|-------------|-----------------------|
| <b>Stator end-winding support for short maintenance time</b>                | ●                              | ●                              | ●           | ●                     |
| <b>Enhanced stator bars insulation for reliable operation</b>               | MICADUR VPI                    | MICADUR VPI                    | MICADUR VPI | DURITENNAX Resin Rich |
| <b>Concave-convex wedges for reliability and short maintenance time</b>     | ●                              | ●                              | ●           | Ripple Spring System  |
| <b>Enhanced stator core design for low losses and maintenance</b>           | ●                              | ●                              | ●           | ●                     |
| <b>Enhanced seal oil system for low hydrogen losses and high efficiency</b> | Triple-circuit seal oil system | Single-circuit seal oil system | -           | -                     |
| <b>Enhanced cooling system for high efficiency</b>                          | Hydrogen and water             | Hydrogen                       | Air         | Air                   |
| <b>Skid-mounted auxiliaries that save time on site</b>                      | ●                              | ●                              | -           | -                     |
| <b>Total GE Installed fleets</b>  | 680                            | 3551                           | 4458        | 1180                  |



## GEN-W: Water-Cooled

### Reliable water cooled generator

The 2-pole hydrogen and water-cooled generator is used for coal power plants, nuclear full speed turbines, and gas power plants and can be found in over 680 systems since 1961. Flexible in design, each machine fits the end user's power needs with high efficiency. This generator has proven to be highly reliable.

Based on technology pioneered in the 1970s, the GEN-W Water-Cooled generator is constantly improved with continuous feedback from operational experience worldwide. Designed for both rail and road transport, the generator has only a small number of individual parts, which translates into shorter delivery and faster installation time.

### Applications

- GEN-W generator is well-suited for the nuclear full-speed Turbine Generator package.
- GEN-W generator represents more than 680 units installed.

### SUCCESS STORIES

#### First 1,000 MW coal plant in China from GE

Since the rail network in China has narrow tunnel profiles and load restrictions, a specific GEN-W generator was designed to fulfill all of China's specific technical and rail transportation requirements for dimensions and weight.

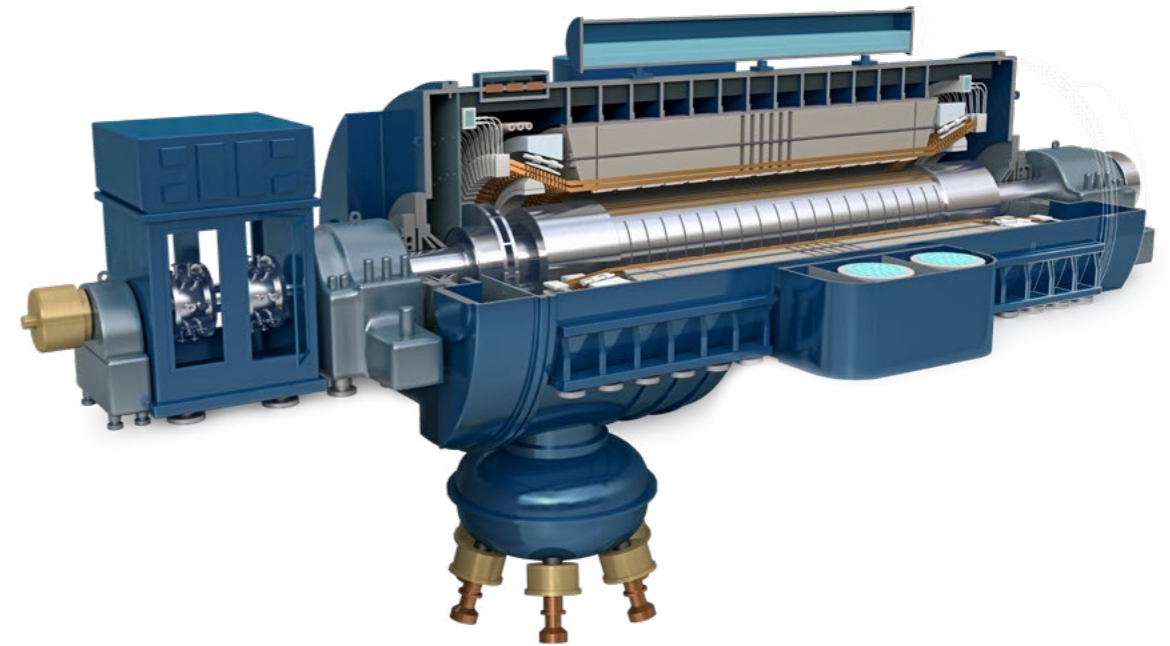

|                         |                     |                     |
|-------------------------|---------------------|---------------------|
| <b>Frequency</b>        | 50 Hz               | 60 Hz               |
| <b>Power factor</b>     | 0.8 to 0.9          | 0.85                |
| <b>Apparent power</b>   | 600 MVA to 1400 MVA | 600 MVA to 1050 MVA |
| <b>Efficiency</b>       | Up to 99%           | Up to 98.9%         |
| <b>Terminal voltage</b> | 18 kV to 27 kV      | 22 kV to 26 kV      |
| <b>Reliability*</b>     | 99.996%             | 99.996%             |

\*Average reliability calculated according to standard IEEE-762 from measurements collected over nine GEN-W units between 1990 and 2012 by the independent company Strategic Power System

### Key features

#### High power output levels

For example, the GEN-W generator in the operation in Leibstadt (Switzerland) nuclear plant at 1,190 MW.

#### Robust and reliable design

The design takes into account normal operation and transients.

#### Efficient and flexible

The cooling system sustains a high level of efficiency and has a unique design of press plates for higher reactive power and stabilization in case of grid disturbance.

#### Continuously evolving technology

The first model was developed in the 1960s and has evolved continuously ever since, based on feedback collected from operating experience.

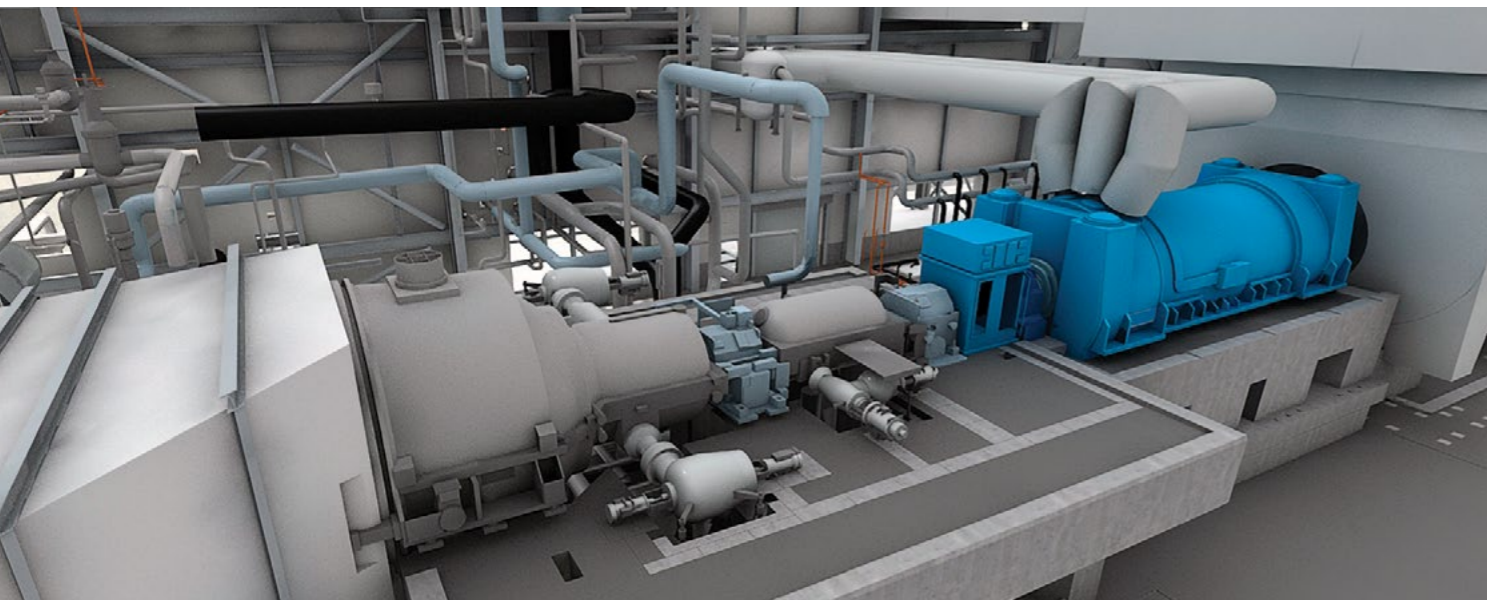

## GEN-H: Hydrogen-Cooled

### Best-in-class hydrogen-cooled generator

GEN-H hydrogen-cooled generators benefit from a strong heritage of technology and extensive operational feedback. The GEN-H power output range is a cost-effective alternative to bigger and more complex hydrogen-water-cooled generators.

The low density, high specific heat and high thermal conductivity of hydrogen gas enables the highest efficiency generators on GE's portfolio. Hydrogen-cooled generators use proven technologies and advanced materials.

#### SUCCESS STORIES

##### GEN-H in high cyclic operation

A unit in a 400 MW gas-fired combined cycle plant, powering a Japanese steel production facility, has been operating reliably in daily start-stop mode since September 2002, accumulating more than 2,050 starts & more than 48,000 operating hours.

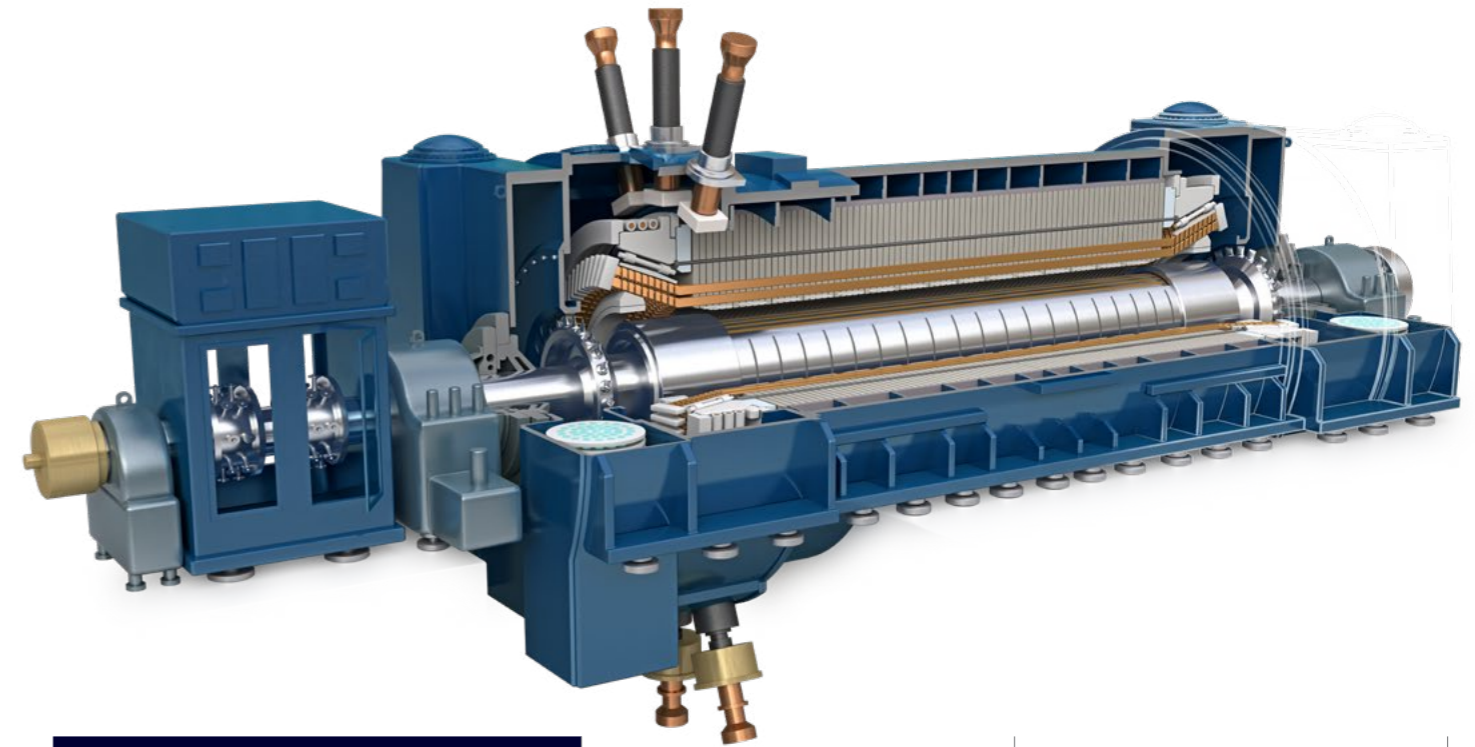

|                         |                    |                    |
|-------------------------|--------------------|--------------------|
| <b>Frequency</b>        | 50 Hz              | 60 Hz              |
| <b>Power factor</b>     | 0.8                | 0.85               |
| <b>Apparent power</b>   | 320 MVA to 710 MVA | 280 MVA to 690 MVA |
| <b>Efficiency</b>       | Up to 98.9%        | Up to 99%          |
| <b>Terminal voltage</b> | 18 kV to 23 kV     | 19 kV to 25 kV     |
| <b>Reliability*</b>     | 99.715%            | 99.715%            |

\* Average reliability calculated according to Standard IEEE-762 from measurements collected from 34 GEN-H units between 1998 and 2012 by the independent company Strategic Power System.

### Key features

#### Lower investment cost

Derived from the high power rating and the generator's efficiency, GEN-H machines are a cost-effective alternative to more complex hydrogen-water-cooled generators that normally are used for similar power output levels

#### High efficiency of around 99%

Mainly because of the enhanced winding and hydrogen cooling system

#### Excellent 99.7 % reliability

Based on measurements collected from 34 units between 1998 and 2012.

#### Easy to maintain

Thanks to specific design features of the stator bar wedging and stator end-winding support parts





## GEN-A: Air-Cooled

### Precise and robust air-cooled generator

The most powerful air-cooled generator in operation today, GE's GEN-A unit has accumulated worldwide operational experience from more than 570 installations. It is a robust machine providing high reliability and maintainability.

Air-cooled generators have a power output range that usually is found in larger and less cost-effective hydrogen-cooled generators. This is the result of continuous, evolutionary development that has pushed the limits of power output while enhancing efficiency and controlling investment costs.

At the same time, it is simple and easy to operate and maintain. The flexible GEN-A, because of its short production time (parallel manufacture of stator and casing, pre-assembly, and ease of transport), is a generator that can be up and running quickly. This reduces construction and commissioning time and accelerates plant revenue flow. GEN-A units are available in standardized sizes, with different capabilities and performances.

#### SUCCESS STORIES

##### **GEN-A (TOPAIR) working in a tough environment**

More than 200 GEN-A generators have been installed in the Middle East, where their durability and robustness are tested to the limit by extreme operating conditions. 32 GEN-A units have been operating in Saudi Arabia since 1978. Bahrain is host to one of the world's largest air-cooled generators, which has been operating since 1999 and has accumulated more than a million operating hours.

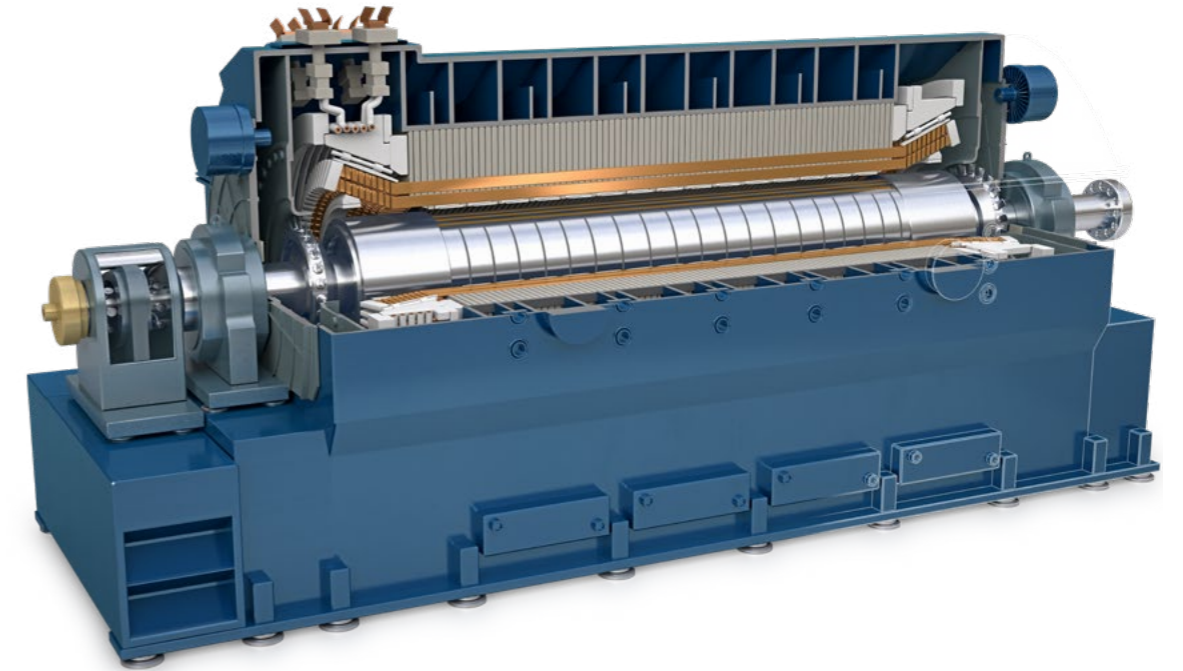

|                         |                    |                    |
|-------------------------|--------------------|--------------------|
| <b>Frequency</b>        | 50 Hz              | 60 Hz              |
| <b>Power factor</b>     | 0.8                | 0.85               |
| <b>Apparent power</b>   | 200 MVA to 400 MVA | 200 MVA to 345 MVA |
| <b>Efficiency</b>       | Up to 98.9%        | Up to 98.9%        |
| <b>Terminal voltage</b> | 11.5 kV to 22 kV   | 13.8 kV to 22 kV   |
| <b>Reliability*</b>     | 99.911%            | 99.911%            |

\* Average reliability calculated according to Standard IEEE-762 from measurements collected from 304 GEN-A units between 1990 and 2012 by the independent company Strategic Power System.

### Key features

#### Cost advantage

Due to high power rating and over hydrogen-cooled equivalent efficiency generators

#### Proven operational flexibility

From demonstrated robustness and reliability over many years in all operation modes

#### Continuous improvement

Based on measurements collected from 34 units between 1998 and 2012

#### Extensive worldwide

Operational experience with more than 570 units installed worldwide



## GEN-A: Air-Cooled

### Packaged air-cooled generator

The packaged, air-cooled generator is remarkable for its breadth of customer advantages and its accumulated experience.

The packaged GEN-A solution comes complete with all necessary electrical equipment, saving our customers time, effort and money. Compact and modular, based on standardized manufacturing processes, a GEN-A generator quickly gives our customers exactly what they need. It is delivered as a single unit that is ready to install, simple to integrate into the power plant, and easy to maintain.

The GEN-A generator is highly reliable, with a wide power range that is versatile enough to handle all kinds of applications – indoor or outdoor and in a variety of climates. GEN-A generators are available in standardized sizes, with different capabilities and performances.

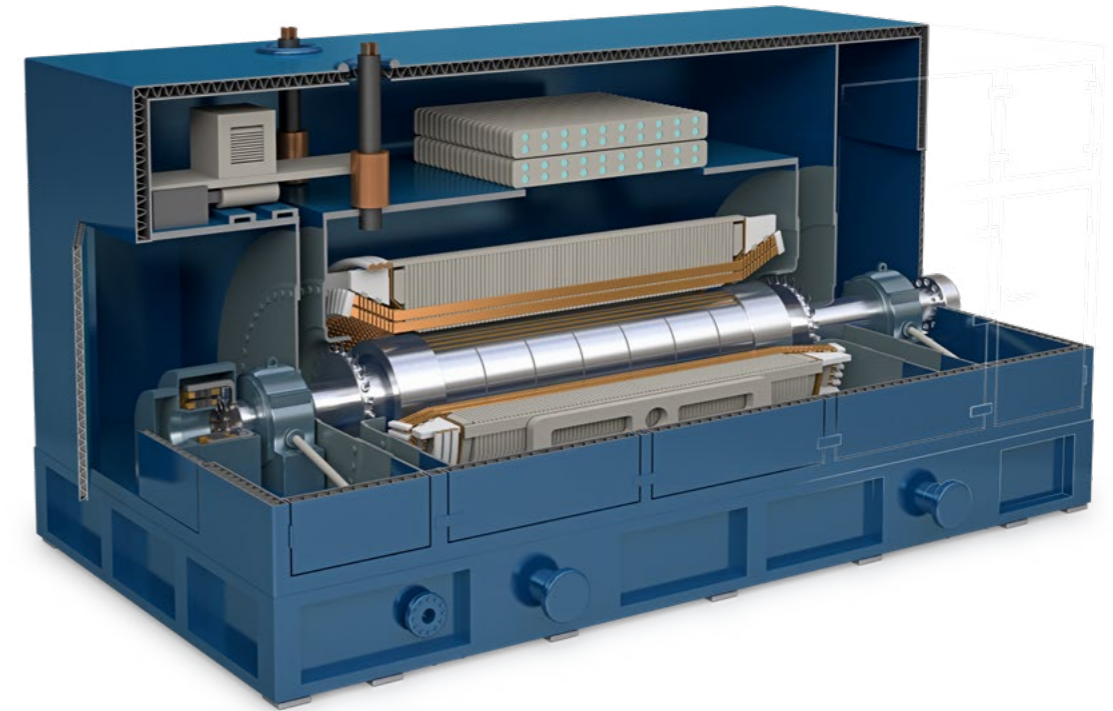

|                         |                   |                   |
|-------------------------|-------------------|-------------------|
| <b>Frequency</b>        | 50 Hz             | 60 Hz             |
| <b>Power factor</b>     | 0.8               | 0.85              |
| <b>Apparent power</b>   | 45 MVA to 200 MVA | 45 MVA to 200 MVA |
| <b>Efficiency</b>       | Up to 98.7%       | Up to 98.6%       |
| <b>Terminal voltage</b> | 11 kV to 15 kV    | 13.8 kV           |

### SUCCESS STORIES

#### Extreme operating conditions

A refinery in Kazakhstan is located at one of the largest oil fields in the world & faces extreme ambient temperatures reaching -36°C. 2 GEN-A units are installed there to produce electrical power and these machines have operated reliably for more than 10 years.

### Key features

#### Fully packed

Generator that comes complete with all electrical systems

#### Compact size & easy maintenance

For quick and easy transportation and installation

#### Reliable and robust

Product, with more than 1,180 installations worldwide and proven in many different environments

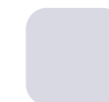
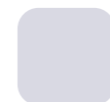

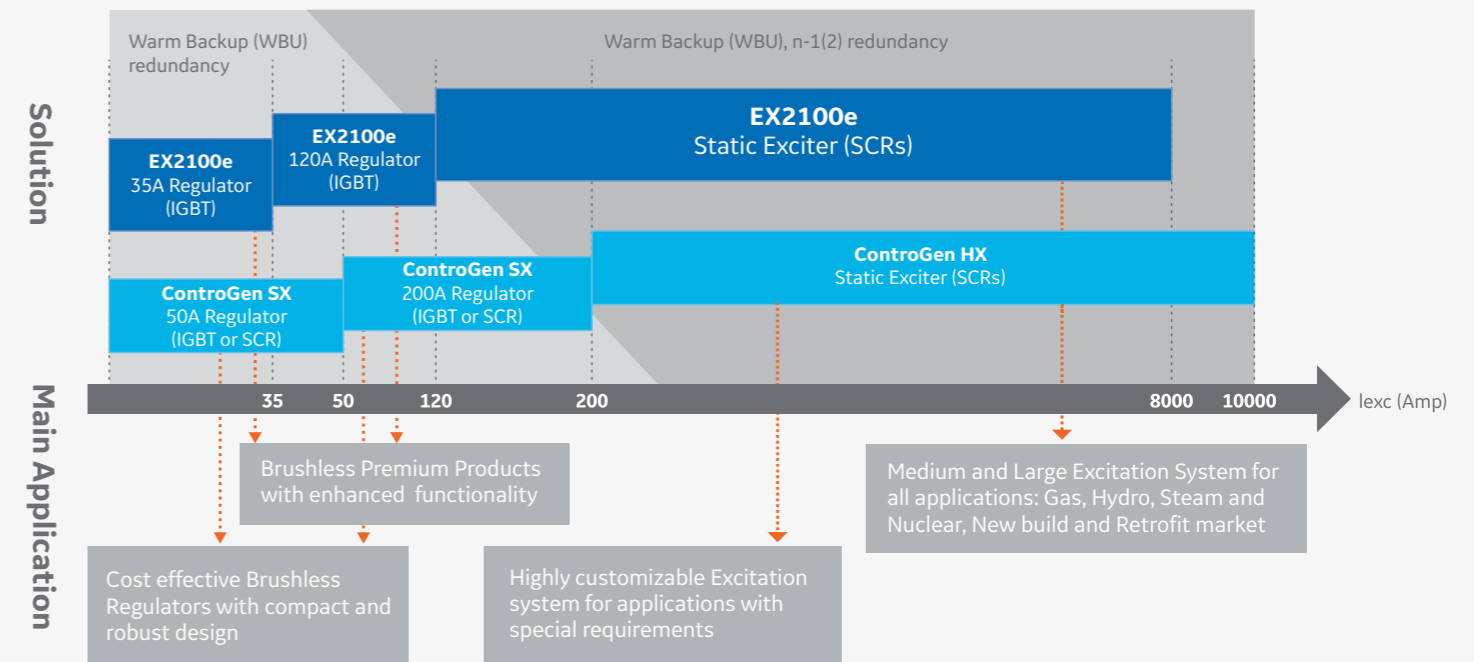

### A flexible and configurable portfolio across a range of power generation applications

GE has developed a broad portfolio of excitation solutions to respond to your specific requirements. These range from standardized configurations offering added value and short lead times, to flexible and customizable solutions for more demanding applications.

**Depending on your needs, your excitation solution can be delivered with the following redundancy configurations:**

- Simplex configuration (no redundancy)
- Control redundancy
- Power bridge redundancy: Dual, N-1, N-2
- Cooling systems redundancy
- Power supplies redundancy

GE's complete portfolio offers excitation solutions for both brushless and static applications across two product lines, EX2100e and ControGen\*. The ControGen platform extends the excitation portfolio to high current applications.

EX2100e and ControGen SX regulators are designed for brushless applications.

EX2100e regulators are available in two versions, 35A and 120A (excitation currents up to 35A and 120A respectively). These regulators offer a standardized solution based on the Mark VIe control platform, which can provide seamless integration for customers already using the Mark VIe distributed control systems (DCS) and turbine controls in order to maintain a consistent hardware platform. It also helps to streamline plant operation and maintenance, since both the plant control system and excitation solution share the same development, diagnostic, and troubleshooting tools. This greatly simplifies training of operation personnel.

EX2100e regulators are designed with the latest Insulated Gate Bipolar Transistor (IGBT) technologies, using an H-bridge configuration and IGBT-controlled active discharge design for better excitation current control.

ControGen SX, a second regulator solution for brushless applications, features two versions, 50A and 200A. The compact design of the 50A regulator provides a low-footprint solution for demanding

brushless applications. It is designed for both new projects and retrofit projects requiring a high degree of customization, specific packaging, and complex mechanical integration. The 50A ControGen SX regulator provides additional flexibility regarding the power technology. Customers can opt for either IGBT chopper-based configuration or Silicon Controlled Rectifier (SCR) configuration.

The 200A ControGen SX regulator, based on an "all-in-one-box" concept for the control and communication modules and separated SCR power bridge, is designed for higher excitation currents up to 200A with full flexibility for integration, satisfying the most demanding retrofit projects.

**The EX2100e static exciter solution is based on GE's Mark VIe control platform with two options:**

- A standardized option with predefined configurations, offering better value and shorter lead time
- A more open and flexible option, for more demanding applications, providing a range of customization possibilities.

The embedded Mark VIe hardware platform enables EX2100e static exciters

to interface easily with other Mark VIe products (DCS and turbine control). This reduces the complexity of plant operation and maintenance thanks to the common development, diagnostic and troubleshooting tools.

More complex and demanding static excitation applications require the ControGen HX solution, with increased customization options available for the control, communication and power technology. ControGen HX can deliver excitation currents as high as 10000A with its control designed to drive up to 6 SCR bridges and with active current sharing capability ensuring optimal distribution of current among parallelized power bridges.

**The entire excitation product line is available in several configurations:**

- Can be supplied as a complete excitation system in a single cabinet
- Can be installed (delivered as a kit or as pre-assembled frames) in an existing cubicle

GE offers a complete dismantling, installation, commissioning and training services.



## Regulators

EX2100E 35 A

|                                  |   |
|----------------------------------|---|
| <b>Technology</b>                | IGBT  |
| <b>Configurations</b>            | Simplex/Dual  |
| <b>Nominal Continuous Output</b> | 35 Adc  |
| <b>AC input range</b>            | 90 – 280V rms @ 50/60 to 480hz  |
| <b>DC Input range</b>            | 80-250 V dc   |
| <b>Cooling</b>                   | Air-convection natural cooling  |
| <b>Operating Conditions</b>      | Operating altitude: < 1000m (Higher with derating)<br>Ambient humidity: 0 – 95% non-condensing<br>Ambient Temperature: 0 to 40°C (50°C with derating) |
| <b>Certification</b>             | UL/CSA/CE   |



EX2100e 120A

|                                  |   |
|----------------------------------|---|
| <b>Technology</b>                | IGBT  |
| <b>Configurations</b>            | Simplex/Dual  |
| <b>Nominal Continuous Output</b> | 120 Adc   |
| <b>AC input range</b>            | 90 to 480V rms @ 50/60 to 480hz   |
| <b>DC Input range</b>            | 80-250 V dc   |
| <b>Cooling</b>                   | Air forced cooling (fans)   |
| <b>Operating Conditions</b>      | Operating altitude: < 1000m (Higher with derating)<br>Ambient humidity: 0 – 95% non-condensing<br>Ambient Temperature: 0 to 40°C (50°C with derating) |
| <b>Certification</b>             | UL/CSA/CE   |

### Key features/benefits

- **Performance:** High-performance control and protection features from advanced software tools and a wide list of operational features help drive increased productivity through operational excellence and flexibility.
- **Reliability:** Designed for increased reliability and low lifecycle cost thanks to a design based on a simplified architecture (less hardware and cabling, improved troubleshooting).
- **Availability:** Proven technology and advanced redundancy paired with high testing standards help increase availability and productivity.

- **Maintainability:** A simplified control architecture, combined with long-term support and world-class parts and service, improves maintainability.

### Ideal Applications

- EX2100e Regulators are designed for brushless excitation application for all generation plants (gas, steam, hydro, nuclear).



## Regulators

ControGen SX 50A

|                                  |   |
|----------------------------------|---|
| <b>Technology</b>                | IGBT or SCR   |
| <b>Configurations</b>            | Simplex/Dual  |
| <b>Nominal Continuous Output</b> | 50 Adc  |
| <b>AC input range</b>            | 20-350 Vrms   |
| <b>DC Input range</b>            | On project basis – customization  |
| <b>Cooling</b>                   | Air-convection natural cooling  |
| <b>Operating Conditions</b>      | Operating altitude: < 1000m (Higher with derating)<br>Ambient humidity: 0 – 95% non-condensing<br>Ambient Temperature: 0 to 40°C (50°C with derating) |
| <b>Certification</b>             | CE  |



ControGen SX 200A

|                                  |   |
|----------------------------------|---|
| <b>Technology</b>                | SCR   |
| <b>Configurations</b>            | Simplex/ Dual   |
| <b>Nominal Continuous Output</b> | 200 Adc   |
| <b>AC input range</b>            | 20-350 Vrms   |
| <b>DC Input range</b>            | On project basis – customization  |
| <b>Cooling</b>                   | Air-convection natural cooling  |
| <b>Operating Conditions</b>      | Operating altitude: < 1000m (Higher with derating)<br>Ambient humidity: 0 – 95% non-condensing<br>Ambient Temperature: 0 to 40°C (50°C with derating) |
| <b>Certification</b>             | CE  |

### Key features/benefits

- **Extended capacities:** An all-in-one, powerful system suitable for fleet-wide application, reducing capital and operational overhead.
- **Reliability:** Compact, robust design with redundant architecture and integrated safety functions for increased reliability.
- **Monitoring and maintenance:** Oscilloscope capacities for easy tuning. Trend recorder for fast troubleshooting.

### Ideal Applications

- ControGen SX regulators can address regulation of AC synchronous generators for all type of plants (steam, gas, hydro).

## Static Excitation Solutions

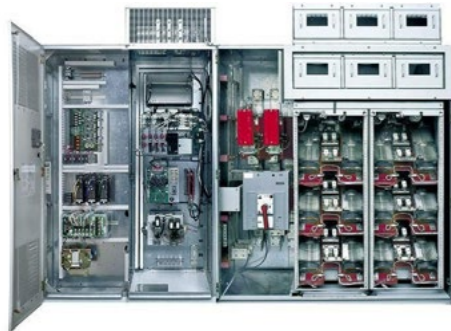

EX2100e

|   |  |
|---|--|
| <b>Technology</b>                                   | SCR  |
| <b>Configurations available (Controller/Bridge)</b> | Dependent on configuration<br>Simplex/Simplex<br>Simplex/Dual<br>Triple Modular Redundancy/ Dual (Warm Back Up)<br>TMR/2, 3 or 4 bridges for 100mm and H2500 options |
| <b>Nominal Continuous Output</b>                    | up to 7700A with the 100mm configuration   |
| <b>AC input range</b>                               | up to 1400Vrms for the 100mm   |
| <b>Cooling</b>                                      | Forced air cooling   |
| <b>Operating Conditions</b>                         | Operating altitude: < 1000m (Higher with derating)<br>Ambient humidity: 0 – 95% non-condensing<br>Ambient Temperature: 0 to 40°C (50°C with derating)                |
| <b>Certification</b>                                | UL, CSA & CE depending on configuration  |

### Key features

- **Performance:** High-performance control and protection features with advanced software tools and a wide list of operational features drive increased productivity through operational excellence and flexibility.
- **Reliability:** Designed for increased reliability and low lifecycle cost thanks to a design based on a simplified architecture (less hardware and cabling, improved troubleshooting).
- **Availability:** Proven technology and advanced redundancy paired with high testing standards help increase availability and productivity.
- **Maintainability:** A simplified control architecture, combined with long-term support and world-class parts and service support, improve maintainability.

### Applications

- EX2100e exciters cover all static excitation applications for all types of power plants (steam, gas, hydro).



## Static Excitation Solutions

ControGen HX

|   |   |
|---|---|
| <b>Technology</b>                                   | SCR   |
| <b>Configurations available (Controller/Bridge)</b> | Simplex/Simplex<br>Dual/Dual (simple or full twin redundancy)<br>Dual/3 (up to 8 bridges)   |
| <b>Nominal Continuous Output</b>                    | Up to 10000A  |
| <b>AC input range</b>                               | 860 Vrms (1)  |
| <b>Cooling</b>                                      | Forced  |
| <b>Operating Conditions</b>                         | Operating altitude: < 1000m (Higher with derating)<br>Ambient humidity: 0 – 95% non-condensing<br>Ambient Temperature: 0 to 40°C (50°C with derating) |
| <b>Certification</b>                                | CE  |

### Key features

- **Performance:** ControGen HX offers advanced functions to help improve the performance of your entire system.
- **Reliability:** The scalable redundancy of the controllers, power supplies, pulse generating devices, and power bridges makes the system tolerant to internal or external failures and helps ensure continuous operation.
- **Customizable:** ControGen HX is a highly customizable excitation system for applications with special requirements.

### Ideal Applications

- ControGen HX can be applied to any kind of power generation applications (steam and hydraulic turbines, gas turbines, and nuclear).

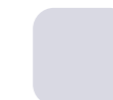
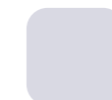

# Condensers

## Proven technology for higher plant performance

For 50 years, more than 1000 of our condensers have been engineered, commissioned and delivered. Over the past 35 years, we have retrofitted more than 70 condenser tube bundles and set a record of 19 days for a retrofit.

GE condensers are designed for each specific installation, meeting sustained high-performance requirements, enhancing reliability, adapting to varied site cooling conditions, and providing simplified construction with pre-assembled modules.

GE's range of condenser technologies (Church Window and Daisy) have been proven to meet highest performance requirements (outperforming HEI standard by up to 30 %) - and to realize highly compact tube bundle designs.

## Key benefits

- Higher performance and reliability, patented tube bundle design and a track record of outstanding performance over the past 50 years.
- Highly efficient tube bundles features
  - Highest heat transfer coefficients and greatest efficiency.
  - No condensate subcooling.
  - Extreme low oxygen content in the condensate.
  - Allows a highly compact customized design to comply with challenging space constraints.
- Reduced costs, simplified construction.
- Condensers are delivered as fully tubed modules, so that little welding is required on site. The condenser typically houses low pressure heaters for simplified arrangement of the turbine building, keeping steam-side pressure losses at minimum by means of advanced steam path optimization.
- Robust design for flexible operation. Is designed to handle turbine and steam generator overloads and variations in cooling water temperature.
- It is resistant to impingement erosion and tube vibration.

## SUCCESS STORIES

### Mannheim 9, Germany - Outstanding condenser performance

In 2015, the condenser of the 900 MW USC power plant has been commissioned and performance measurement substantiate a heat transfer coefficient exceeding 25% of the value calculated as per HEI (Heat Exchange Institute) Standards.

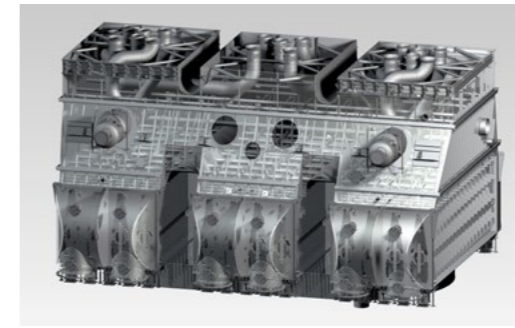

| Typical solutions for:  | 600 MW              | 900 MW          | 1000 MW         |
|---|---------------------|-----------------|-----------------|
| <b>Condenser vacuum type</b>  | Dual                | Single          | Single          |
| <b>Condenser thermal load (MW)</b>                                  | 583                 | 818             | 1139            |
| <b>Absolute pressure at turbine/condenser connection (mbar abs)</b> | 32/42               | 31              | 75              |
| <b>Max condensate O2 content at 100 % load with make-up (ppm)</b>   | 15                  | 15              | 15              |
| <b>Terminal temperature difference (°C)</b>                         | 2.5/2.5             | 2.5             | 4               |
| <b>Circulating water</b>  |                     |                 |                 |
| <b>Circulating water temperature design (°C)</b>                    | 18.4/22.9           | 14.1            | 31              |
| <b>Circulating water nature</b>                                     | Cooling tower water | River water     | Sea water       |
| <b>Circulating water flow (m³/s)</b>                                | 16                  | 25              | 52.9            |
| <b>Circulating water temperature rise (°C)</b>                      | 4.5/4.3             | 8.1             | 5.3             |
| <b>Tubes</b>  |                     |                 |                 |
| <b>Exchange surface (m²)</b>  | 18810/20630         | 40650           | 46530           |
| <b>Material</b>   | Stainless steel     | Stainless steel | Titanium        |
| <b>Length (m)</b>   | 12.8/11.7           | 15.7            | 11.4            |
| <b>Tube to tubesheet joint</b>                                      | Expanded            | Expanded        | Expanded/Welded |
| <b>Weights</b>  |                     |                 |                 |
| <b>In operation (tons)</b>  | 1140                | 1160            | 1450            |
| <b>Dimensions</b>   |                     |                 |                 |
| <b>Overall width (m)</b>  | 6.7/6.7             | 23.9            | 18.3            |
| <b>Overall length (m)</b>   | 21.6                | 21.3            | 15.7            |
| <b>Overall height (m)</b>   | 16.8                | 12.9            | 15              |

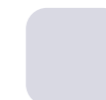
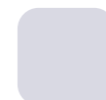

## Feedwater plant package

GE integrates heat exchangers and pumps in the portfolio and brings insight into the steam/water cycle integration.

### Condensate extraction pump

The condensate extraction pumps are from two main families: the vertical multi-stage bowl diffuser type, or can type, with a single- or double-suction impeller and the horizontal multistage in line construction. We offer various configurations, with or without a pump in standby. Multistage arrangements are used for extended applications as combined condensate extraction and polishing. Variable speed drives are available for all types of specifications, including large flow requirements. The pumps are designed to operate safely and economically on a large operating range. The modular design allows for tailored solutions in particular for harsh water conditions.



### Low pressure heaters

GE low pressure feedwater heaters are of shell and tube type design and contribute to improved plant efficiency by following features:

- High heat transfer due to excellent air removal on the steam side.
- Optimal partition of the heat exchange area into condensing and subcooling zones.
- Optimal thermodynamic and economic integration into the steam/water cycle.
- Customized duplex heater solutions for optimized arrangement in condenser neck.

Our custom-manufactured LP heaters offer outstanding reliability.



### Feedwater storage tank and deaerator

This combined unit performs three functions: It eliminates all oxygen to avoid any damage to the boiler and steam generator respectively, it also heats the feedwater with a steam extraction from the turbine, and it provides a reserve of deaerated and heated water, necessary for follow plant operation. Our technology covers spray, tray and re-boiling deaerator types which allow to meet customer and plant requirements in an optimum way.



### Vertical turbine pumps

GE's proven vertical turbine pumps are highly efficient for power plant water main cooling and SWFGD systems. The outstanding hydraulic database allows setting up your pumps with the best in class efficiency with axial, mixed flow or centrifugal impellers. Our pumps are designed to be robust and reliable with the use of Duplex alloy for harsh sea water quality and easy to maintain with GE's simple, light and efficient design.



Quantitative analysis and heat balance models help determine preferred configuration. Customers can expect operational flexibility, high efficiency and reliability, and overall cost effectiveness.

### High pressure heaters

Feedwater heaters are used in a regenerative water-steam cycle to improve the thermodynamic efficiency. Our HP heaters are tubesheet type heat exchangers of shell and tube design. The design ensures high heat transfer, optimum partition into the different heat exchange areas (desuperheating, condensation, subcooling) and economic integration into the w/s cycle.

GE offers separate topping desuperheaters to establish optimum w/s cycle configurations.

GE HP feedwater heaters provide a robust design for flexible plant operation, supported by state-of-the-art design methods to assess and improve lifetime requirements.



### Concrete volute pumps

GE's concrete volute pumps offer high reliability, averaging above 99.9% in more than 30 years of proven operation, with a very high flow rate (up to 50 m<sup>3</sup>/s). The simple design with minimal components and enhanced corrosion-resistant features makes concrete volute pumps particularly suitable to sites where large volumes of water must be pumped such as cooling water and SWFGD systems.



#### SUCCESS STORIES

##### **Belchatow, Poland - Single train HP feedwater heaters**

Large HP feedwater heaters with a tubesheet diameter of ~2.5 m and a thickness >550 mm have been successful in operation since commissioning during 2011.

PORTFOLIO AND OVERVIEW

# AIR QUALITY CONTROL SYSTEMS (AQCS)

Providing advanced emission controls, we offer a variety of solutions to upgrade our customers' existing equipment with our latest innovations for improved performance and low/or lower operating cost.



## Pioneer in air quality control for power and industrial applications

We have provided our customers with advanced air quality control systems (AQCS) for more than 80 years. GE's expertise, technology and comprehensive product portfolio enable our customers to meet and exceed today's stringent emission regulations for particulate and gaseous pollutants emitted from power plants and industrial operations.

### Our success

**80** years

of experience providing advanced emission controls

**500** GW

In power applications

**6000**

Units in industrial applications

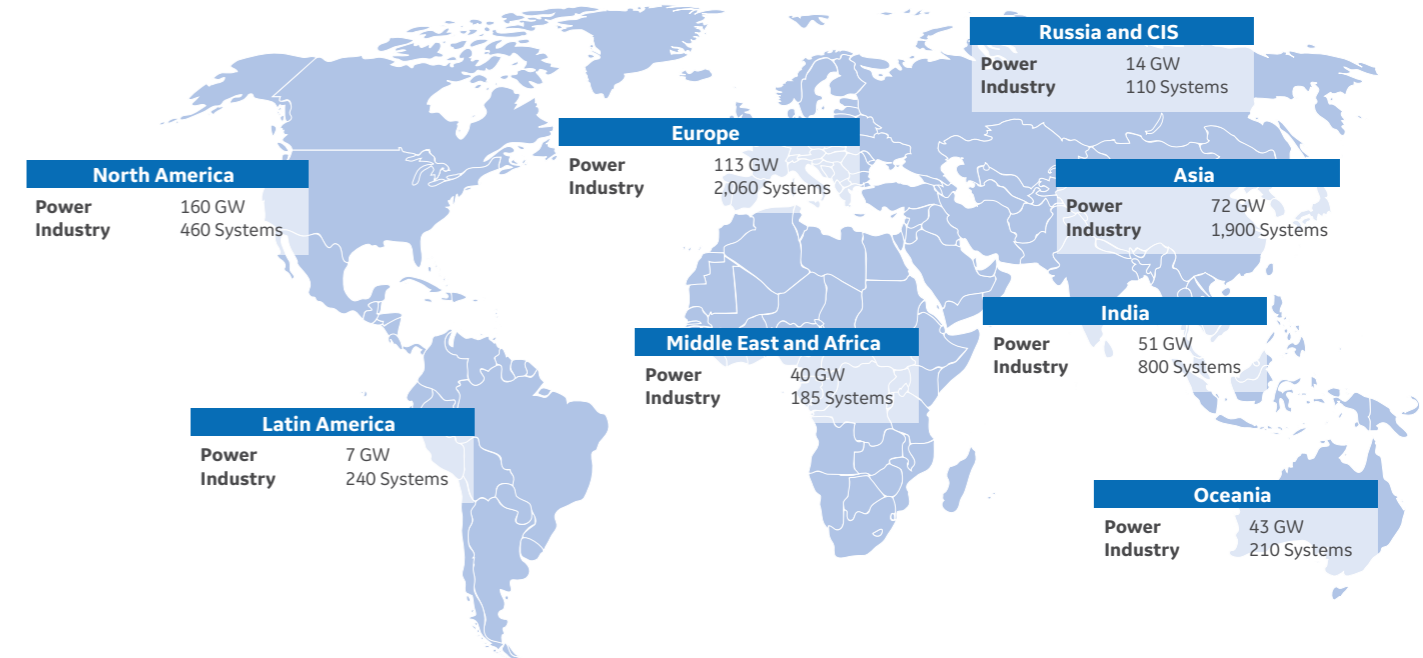

Meet and exceed the most stringent gas emission regulation requirements for Power and Industrial plants

Wide operating range in terms of inlet conditions enabling flexible and reliable operations

Compact footprint reducing construction cost

Low power consumption resulting in low OPEX



# Particulate control

## Dry and wet electrostatic precipitators (ESPs)

Advancements in GE ESP technologies over the past decade have produced continued improvement in particulate removal efficiency, reductions in capital costs and footprint. GE offers a wide range of robust, cost effective and reliable ESP designs for a variety of applications.

Backed by decades of experience on an extended range of fuel combinations and industrial applications, our solutions cater to increasingly strict regulations at a lower life cycle cost. We offer:

- Spiral and rigid designs of emitting electrodes
- Tumbling hammer and electric impact rapping systems
- Flexible layout and modular designs
- Integrated ESP control systems, including the latest generation of EPIC controller for enhanced ESP performance and power savings
- Switched Integrated Rectifiers (SIR) for increased power input, lower power losses and improved particulate removal efficiency. Ideal for performance enhancements of existing ESPs.

### Key features of dry ESP

- Cost efficient modular design
- Less than 10 mg/Nm<sup>3</sup> emissions
- More than 242 GW installed in power generation

In addition to dry ESP technology, GE also offers horizontal wet ESPs for specific applications

### Key features of wet ESP

- Ultra-low particulate emissions (less than 1mg/Nm<sup>3</sup>), acid mists, aerosols, hazardous air pollutants (HAPs)
- More than 80 references for various applications

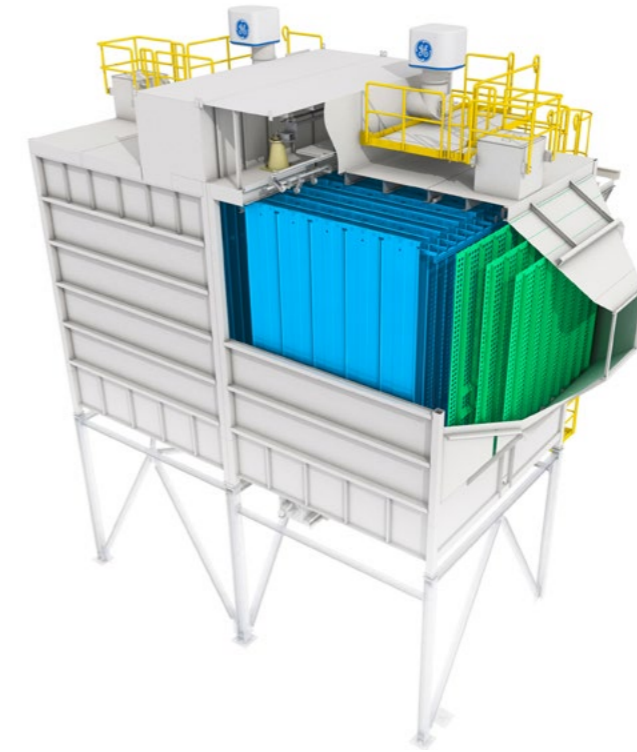

### Dry ESP

|   |  |
|---|--|
| <b>Applications</b>                                 | Power - Boilers and Heaters, Industry* |
| <b>Power capacity (MWe)</b>                         | 10 to 1300                             |
| <b>Gas temperatures (°C)</b>                        | 25 – 400                               |
| <b>Dust loading at ESP inlet (g/Nm<sup>3</sup>)</b> | 0.2 – 200                              |
| <b>Emission at ESP outlet (mg/Nm<sup>3</sup>)</b>   | Down to 10-30 (filterable only)        |

### Wet ESP

|  |  |
|--|--|
| <b>Applications</b>                                  | Power - Boilers and Heaters, Synthesis gas and Industry* |
| <b>Gas temperatures (°C)</b>                         | Up to 70, saturated gas                                  |
| <b>Gas flow rate (m<sup>3</sup>/s)</b>               | 15 – 2000  |
| <b>Dust loading at ESP inlet (g/Nm<sup>3</sup>)</b>  | Up to 1.2  |
| <b>PM Emission at ESP outlet (mg/Nm<sup>3</sup>)</b> | Down to 0.5 (filterable only)                            |
| <b>SO<sub>3</sub> Emissions (ppm)</b>                | Down to 1  |

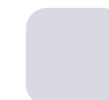
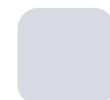

# Particulate control

## Fabric Filter (FF)

GE fabric filters have been developed over the past decade for lower particulate emissions, reductions in capital cost and footprint. GE fabric filters offer a robust solution especially when the dust characteristics are challenging or variable. GE offers both high ratio (pulse jet) and low ratio (reverse air) options.

Fabric filters may be used stand-alone or integrated in Dry Flue Gas Desulfurization (DFGD) solutions (NID or SDA), for dry scrubbing in the aluminum industry (Abart™), or as the principal and polishing filters in mercury control solutions (Mer-Cure™ or Filsorption™).

### Key features:

- Lower than 5 mg/Nm<sup>3</sup> particulate emissions achievable, greater than 99.97% particulates, high PM10 and PM 2.5 removal rate
- More than 47 GW installed in power applications
- Filters with bags up to 12 meters tall for reduced footprint and operational costs
- Large fuel flexibility and ability to handle varying boiler loads
- Renowned OPTIPULSE™ filtration technology with gravimetric flow and OPTIPOW™ plunger valves for efficient bag cleaning
- Modulated Pulse Cleaning for longer bag life and lower particulate emission
- Stand-alone or integrated in multi-pollutant systems
- Latest advanced controller for superior FF performance
- The combination of OPTIPOW™ valves and advanced controller on a new or existing fabric filter provides longer bag life compared to other solutions available in the market

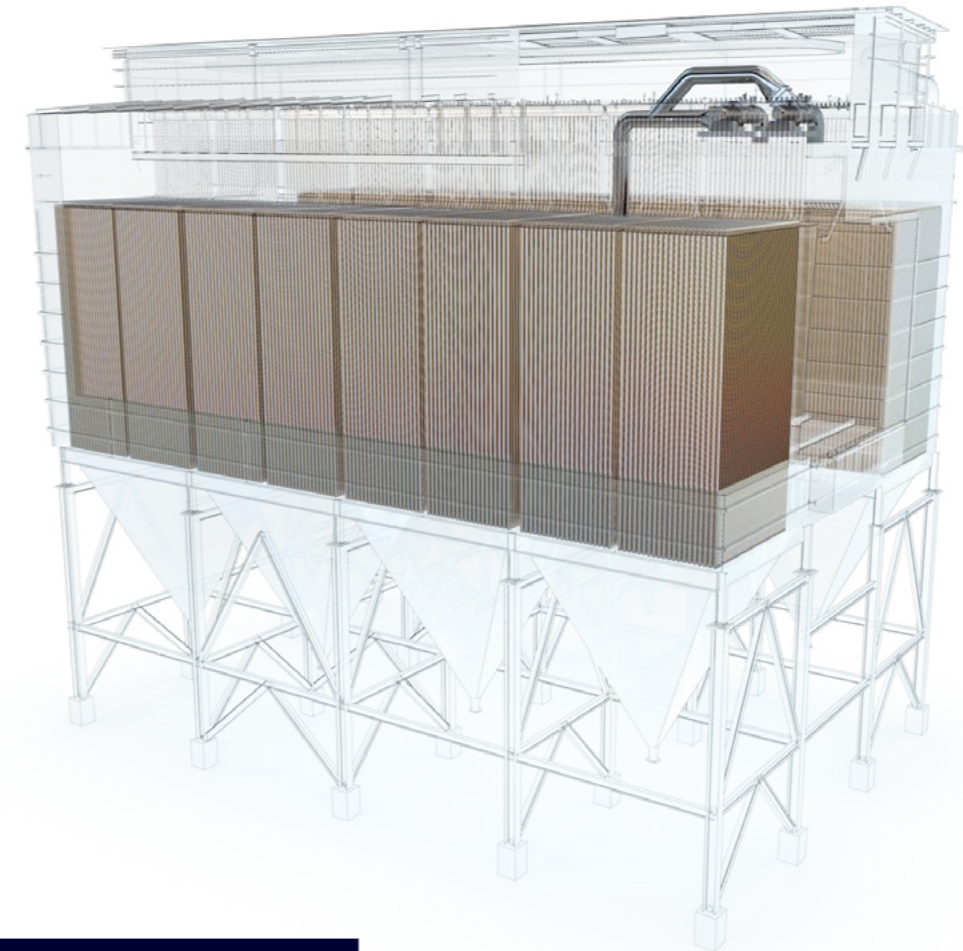

|  |   |
|--|---|
| <b>Types</b>                                       | Pulse jet filters and Reverse air filters       |
| <b>Applications</b>                                | Power – Boilers and Heaters, Industry*          |
| <b>Power capacity (MWe)</b>                        | 10 to 1000                                      |
| <b>Gas temperatures (°C)</b>                       | 25 – 260  |
| <b>Dust loading at FF inlet (g/Nm<sup>3</sup>)</b> | 2 – 100, for DFGD application up to 2000        |
| <b>Emission at FF outlet (mg/Nm<sup>3</sup>)</b>   | Down to 1-5 (filterable only)                   |
| <b>Bag life guarantee (Years)</b>                  | 1 to 6 depending on application and filter type |

\* Industry- Cement: Kiln, Mills, Cooler; Auxiliary dedusting, Iron & Steel: sintering, pelletization, cast house, stock house, coke oven; Biomass fired boilers; Waste to Energy plants; Pulp & Paper: lime kiln et.al.

### SUCCESS STORIES

**GE has installed one mega fabric filter after boiler no 4 at the Manjung power plant in Malaysia.** This unit is of 1000 MWe capacity. The fabric filter has 10 m long bags and is divided into 20 compartments. It was designed for low emissions for a wide range of coals. The stack emission during the recently conducted performance test was measured at less than 5 mg/Nm<sup>3</sup>.

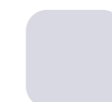
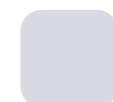

# SOx control

## Dry flue gas desulfurization (DFGD)

Dry desulfurization systems have been used for SOx control and multi-pollutant control for several decades. They are generally based on lime utilization as sorbent and the end product is dry with no need for any waste water treatment as compared to wet systems.

## GE's portfolio of dry flue gas desulfurization (DFGD) solutions includes:

**NID**  
 GE NID technology offers the highest removal efficiency thanks to a collaborative approach with customers. It offers high operability with optimized utilization of absorbents to meet emissions demands on acid gasses and other pollutants. GE robust design results in availability, up to 99%, while reducing downtime with our digital offerings

**Spray dryer absorber (SDA)**  
 This conventional dry FGD system is made up of a reactor followed by a fabric filter. In the reactor, the reagent slurry solution is atomized using either GE's rotary atomizer technology or dual fluid nozzles, and the droplets react with the gaseous pollutants in the flue gas stream.

**Key features:**

- |  |  |
|--|--|
| <p><b>NID</b></p> <ul style="list-style-type: none"> <li>• More than 20 years of successful commercial operation, 19 GW installed for power applications</li> <li>• Up to 98% SO<sub>2</sub> removal, up to 4% sulfur in coal, multi-pollutant control</li> <li>• Compact footprint: less than 50%, compared to Spray Dryer Absorber (SDA)</li> <li>• Modular and standard design to reduce construction costs and provide scalability from small projects up to very large power plant</li> <li>• Simple operation and maintenance; low operational costs</li> <li>• Can be combined with PAC injection for efficient mercury capture.</li> </ul> | <p><b>SDA</b></p> <ul style="list-style-type: none"> <li>• More than 35 years of experience, 17 GW installed capacity for power applications</li> <li>• More than 80 references for various applications</li> <li>• Can be combined with PAC injection for efficient mercury capture.</li> </ul> |
|--|--|

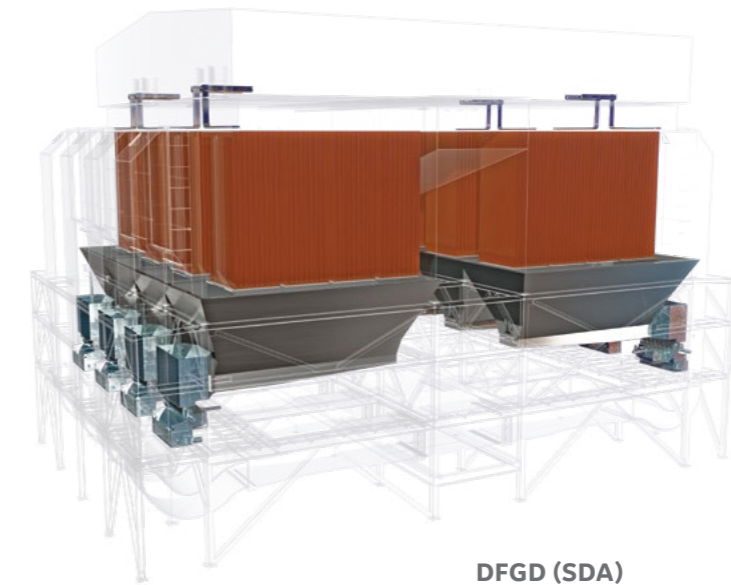

**DFGD (NID)**

|  |                            |
|--|----------------------------|
| <b>SO<sub>2</sub> Removal rate (%)</b>                             | Up to 98                   |
| <b>SO<sub>3</sub> Removal rate (%)</b>                             | Up to 95                   |
| <b>HCl Removal rate (%)</b>  | Up to 95                   |
| <b>HF Removal rate (%)</b>   | Up to 95                   |
| <b>Maximum SO<sub>2</sub> content at inlet (mg/Nm<sup>3</sup>)</b> | 10,000                     |
| <b>Particulate emission guarantee (mg/Nm<sup>3</sup>)</b>          | 10                         |
| <b>Fuel</b>  | Applicable for all fuels   |
| <b>Max inlet temperature (°C)</b>                                  | 200                        |
| <b>Load range per module (%)</b>                                   | 50 - 100                   |
| <b>Reagent</b>   | Ca(OH) <sub>2</sub> or CaO |

**DFGD (SDA)**

|  |                            |
|--|----------------------------|
| <b>SO<sub>2</sub> Removal rate (%)</b>                             | Up to 98                   |
| <b>SO<sub>3</sub> Removal rate (%)</b>                             | Up to 95                   |
| <b>HCl Removal rate (%)</b>  | Up to 95                   |
| <b>HF Removal rate (%)</b>   | Up to 95                   |
| <b>Maximum SO<sub>2</sub> content at inlet (mg/Nm<sup>3</sup>)</b> | 6,000                      |
| <b>Particulate emission guarantee (mg/Nm<sup>3</sup>)</b>          | 10                         |
| <b>Fuel</b>  | Applicable for all fuels   |
| <b>Max inlet temperature (°C)</b>                                  | 260                        |
| <b>Load range per module (%)</b>                                   | 15 - 100                   |
| <b>Reagent</b>   | Ca(OH) <sub>2</sub> or CaO |

GE desulfurisation solutions enable to exceed the most stringent requirements of gas emission regulations for power plants with a variety of technologies. GE SOx control technologies are able to cope with wide operating ranges in terms of fuel, flow-rate and offer simple operation and maintenance with the highest availability for low CAPEX and OPEX.

# SOx control

## Wet flue gas desulfurization (WFGD)

GE 3rd generation WFGD design facilitates an efficient reaction allowing pollutant removal of more than 99.5% of all the acid gases such as: SO<sub>2</sub>, HCl, HF. With GE advanced control technology, it offers installation flexibility on different types of power plant at various load operation. Thanks to its 50-year experience in designing WFGD, GE is guaranteeing the highest availability up to 99% and further reduces downtime with GE digital offerings.

### GE's WFGD portfolio consists of the following options:

#### WFGD-open spray tower (OST)

The third generation WFD-OST operates over a range of 300 to 1,300 MW. The system offers lower power consumption and has smaller dimensions and lower cost compared to previous generations, while reaching nearly zero emissions. The gypsum by-product recovered is usable in wallboard or cement.

#### GE's Flowpac WFGD

GE's WFGD is designed for unit sizes up to 360 MW. In this turbulent bed absorber, flue gas passes through a bed of gypsum and limestone slurry. It is targeted for applications with fuels having medium to high sulfur content and requiring increased SO<sub>2</sub> and SO<sub>3</sub> removal efficiency. In addition, it is well suited for varying fuel conditions.

#### Sea water FGD (SWFGD) technology

GE's SWFGD is a unique no by-product SO<sub>2</sub> removal solution. Thanks to more than 40 years of experience in SWFGD technology for power generation and industry applications, we are the leading provider of SWFGD for power generation and industry applications.

Recent improvements is seawater distribution in the absorber and improved air addition approach and design approach in the seawater treatment plant (SWTP) have reduced system power consumption and reduced footprint.

#### Key features:

#### WFGD (OST)

- Approximately 60 GW installed capacity
- Flexible absorber performance with controllability of the SO<sub>2</sub> removal rate
- Improved performance control through patented SulfiTrac™ sulfite analyzer. Reduces mercury emissions, saves power, and improves treatability of purge water
- Fuel flexibility for all types of fuel (including heavy fuel oil)
- Lower power consumption with lower emissions of particulates and aerosols

#### SWFGD

- An economical desulfurization solution for plants in coastal areas
- Approximately 51 GW in operation or under construction for a variety of applications and a wide range of fuels
- No solid reagent or byproduct handling or disposal and related operating costs



#### SWFGD

|  |   |
|--|---|
| <b>Maximum gas flow rate - per absorber (Nm<sup>3</sup>/h)</b>     | 3,400,000                                     |
| <b>Power plant size (MW)</b>                                       | up to 1,000                                   |
| <b>Fuel</b>  | Coal, lignite, oil, HFO, industrial processes |
| <b>Maximum SO<sub>2</sub> content at inlet (mg/Nm<sup>3</sup>)</b> | 15,000  |
| <b>SO<sub>2</sub> Removal rate with GGH (%)</b>                    | 98  |
| <b>SO<sub>2</sub> Emissions (mg/Nm<sup>3</sup>)</b>                | 30  |
| <b>Load range (% MCR)</b>  | 20 - 100                                      |
| <b>Seawater temperature inlet to absorber (°C)</b>                 | 4 - 45  |
| <b>Alkalinity - minimum (mmol/l)</b>                               | 1.2   |
| <b>pH Seawater inlet (minimum)</b>                                 | 7.7   |

#### WFGD OST

|  |   |
|--|---|
| <b>Maximum gas flow rate - per absorber (Nm<sup>3</sup>/h)</b>     | 3,200,000                                     |
| <b>Power plant size (MW)</b>                                       | up to 1,300                                   |
| <b>Fuel</b>  | Coal, lignite, oil, HFO, industrial processes |
| <b>Maximum SO<sub>2</sub> content at inlet (mg/Nm<sup>3</sup>)</b> | 17,000  |
| <b>SO<sub>2</sub> Removal rate with GGH (%)</b>                    | > 99 achieved                                 |
| <b>SO<sub>2</sub> Emissions (mg/Nm<sup>3</sup>)</b>                | 15  |
| <b>Load range (% MCR)</b>  | 20 - 100                                      |
| <b>HCl Removal Rate (%)</b>  | > 99  |
| <b>HF Removal Rate (%)</b>   | > 99  |
| <b>Reagent</b>   | Limestone, lime or sodium                     |

# NOx control

## Selective Catalytic Reduction (SCR)

GE's Selective catalytic reduction (SCR) technology controls nitrogen oxides (NOx) formed in combustion processes. With more than 30 years of experience with SCR technology for power generation and industry applications, GE's lower cost DeNOx solutions help customers reach their requested performance levels.

The GE SCR system including ammonia injection, mixing system and unique design features offer the lowest operation cost in combination with high performance and high reliability.

**Key features:**

- More than 49 GW installed with more than 80 installations
- Up to 95% NOx removal, low ammonia slip (less than 2 ppm)
- Proprietary IsoSwirl™ mixing technology and specific ammonia injection grid design for improved performances
- Mercury oxidation capability can be included
- Design for superior flow distribution
- Economizer by-pass to be included if needed
- Partnerships with leading catalyst suppliers

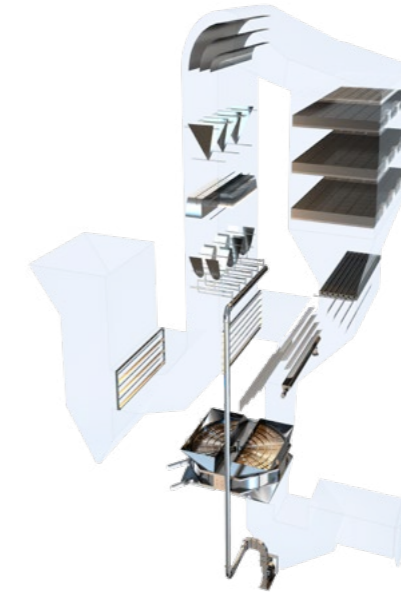

|   |   |
|---|---|
| <b>Reactor size (m³/h)</b>                          | up to 5,400,000   |
| <b>Fuel type</b>                                    | Gas, fuel oil, orimulsion, petroleum coke, biofuel (virgin wood or peat), coal  |
| <b>Reactor position</b>                             | High dust SCR for power plants and CHP plants; tail end SCR for power plants and industrial applications  |
| <b>Reactor flow direction</b>                       | <ul style="list-style-type: none"> <li>• Coal applications: vertical down</li> <li>• Oil applications: vertical up or vertical down</li> <li>• Gas applications: vertical up or vertical down and horizontal</li> </ul> |
| <b>Cleaning method</b>                              | Soot blower using steam or compressed air, sonic air horns, air sweepers  |
| <b>NO<sub>x</sub> Removal efficiency (%)</b>        | Up to 95  |
| <b>NH<sub>3</sub> Slip (ppm)</b>                    | 2   |
| <b>Operation temperature (°C)</b>                   | 300-435 for coal/oil<br>230-454 for gas<br>200-300 for tail end solutions   |
| <b>NO<sub>x</sub> Inlet concentration (ppm)</b>     | 1000  |
| <b>O<sub>2</sub> (%)</b>                            | 1 (minimum)   |
| <b>SO<sub>2</sub> (ppm)</b>                         | up to 3,500   |
| <b>SO<sub>2</sub>/SO<sub>3</sub> Conversion (%)</b> | 0.5 - 2.0   |
| <b>Ash load (mg/Nm³)</b>                            | up to 35,000  |
| <b>Reagent type</b>                                 | Anhydrous ammonia, aqueous ammonia, urea  |

**SUCCESS STORIES**

**In July 2008 EDP, the main power producer in Portugal, chose this technology to retrofit their power station of Sines with four new SCR units.** These SCR units are designed for 81% NOx removal efficiency and use heated ammonia solution as the reagent and a vanadium/titanium honeycomb catalyst. With these SCR units, Portugal has become one of the few countries in Europe to have equipped all of its coal-fired plants with systems to control both SOx (sulfur oxides) and NOx, thus meeting European Union emission targets.

## Other AQCS solutions

In addition to addressing the most common pollutants, such as particulate matter, SOx and NOx, GE offers solutions for capturing other pollutants.

### Mercury

The Filsorption™ system uses activated carbon injection upstream of a standard primary or secondary particulate control system. The Mer-Cure™ system uses a proprietary approach injection of sorbent upstream, for air preheaters, for improved mercury capture.

- More than 25 years and 29 GW installed
- More than two million hours of reliable operation

### Volatile organic compounds (VOC)

For VOC mitigation, GE provides thermal oxidizers and regenerative thermal oxidizers (RTO) – mature technologies that have been sold for many decades. Systems provide heat recovery (steam, hot air, hot oil), and zero fuel operation of RTO.

### Spray dryer evaporator (SDE™) / Zero discharge (ZD)

GE offers a proven SDE™ solution for plants operating WFGD technologies to achieve Zero Discharge (ZD). Our simple and cost effective SDE™ technology uses a slip stream of hot flue gas to evaporate waste water. The dissolved or suspended solids are collected in existing particulate removal equipment, or optionally with a separate collector. Standard truck shippable design is available for smaller applications that reduces costs and project schedule. The SDE™ can evaporate waste water as a stand alone system, or for large waste water flows it can be used along with a brine concentrator to reduce the volume. Optional addition of lime to the wastewater feed stream can provide partial acid gas (SO<sub>3</sub> and HCl) removal.



#### Regenerative thermal oxidizer

|   |               |
|---|---------------|
| <b>Gas flow rate (Nm<sup>3</sup>/min)</b>     | 30-3,000      |
| <b>VOC Concentration (% of LEL)</b>           | 0-25          |
| <b>Load range (%)</b>                         | 33-100        |
| <b>Inlet dust load (mg/Nm<sup>3</sup> wg)</b> | Max 2.0       |
| <b>Oxygen content in process gas (%)</b>      | 8-21          |
| <b>VOC Destruction efficiency (%)</b>         | Up to 95-99.5 |

#### VOC Control Thermal Oxidizer

|   |            |
|---|------------|
| <b>Gas flow rate (Nm<sup>3</sup>/min)</b>     | up to 1200 |
| <b>VOC Concentration (% of LEL)</b>           | 0-25       |
| <b>Load range (%)</b>                         | 33-100     |
| <b>Inlet dust load (mg/Nm<sup>3</sup> wg)</b> | Max 2.0    |
| <b>Oxygen content in process gas (%)</b>      | 10-21      |
| <b>VOC Destruction efficiency (%)</b>         | Max. 99.5  |

**Mercury control filtration for power (typical)**

|  |   |
|--|---|
| <b>Fuel</b>  | Boiler flue gas   |
| <b>Reagent</b>                                     | Activated carbon or activated lignite coke and/or non carbon sorbents |
| <b>Bromine injection</b>                           | Optional depending on the halogen content in the coal                 |
| <b>Removal efficiency (%)</b>                      | Up to 92  |
| <b>Temperature (°C)</b>                            | 200   |
| <b>PAC Addition rate (kg/106 Nm<sup>3</sup>/h)</b> | 50-200  |

**Zero discharge SDE™ for power (typical)**

|   |               |
|---|---------------|
| <b>Evaporation rate (m<sup>3</sup>/h)</b> | 5-35          |
| <b>Wastewater TDS (mg/l)</b>              | Up to 140,000 |
| <b>Wastewater TSS (%)</b>                 | Up to 20      |
| <b>Gas flow rate (Nm<sup>3</sup>/h)</b>   | Up to 500,000 |
| <b>Max inlet temperature (°C)</b>         | 400           |
| <b>Load range per module (%)</b>          | 30-100        |



# Specialized solutions for AQCS

## Solutions for particulate AQCS equipment

### ESP energization, SIR technology

Switch Integrated Rectifiers (SIR) technology offers a cost efficient solution to meet new and more stringent emission legislation as well as reduction of auxiliary power requirements.

#### Key features

- Avoids cost intensive retrofit
- Suitable for ESPs in power and industrial applications, such as coal fired boilers, cement and pulp & paper
- Suitable for installation on new or existing ESPs from GE and also other OEMs
- More than 4000 SIR units in operation around the world; a solution developed in the 1990s
- Reduces particle emissions up to 70% compared to conventional technology, and emission levels down to below 20 mg/Nm<sup>3</sup>, when required
- Highest available energy efficiency, 96% (at rated power)
- Very low reactive power consumption, power factor >90% (at rated power)
- Optimizes power input to ESP



### Switch integrated rectifiers (SIR)

|                                   | SIR4 180                           | SIR4 120   | SIR4 102                            | SIR4 60   | SIR4 35                      |
|-----------------------------------|------------------------------------|--|-------------------------------------|---|------------------------------|
| <b>Sizes Available HV</b>         | 70 kV / 2500 mA<br>85 kV / 2100 mA | 70 kV - 1700 mA<br>85 kV - 1400 mA<br>100 kV - 1200 mA | 70 kV - 1500 mA<br>85 kV - 1200 mA  | 60 kV -1000 mA<br>70 kV - 800 mA<br>85 kV -700 mA | 85 kV - 400 mA               |
| <b>Power Supply Input (50 Hz)</b> | 380 V - 313 A<br>400 V - 297 A     | 400 V - 196 A<br>500 V - 157 A                         | 380 V - 180 A<br>400 V - 175 A      | 380 V - 104 A<br>400 V - 99 A                     | 380 V - 61 A<br>400 V - 58 A |
| <b>Power Supply Input (60 Hz)</b> | 480 V - 248 A                      | 480 V - 163 A  | 480 V - 146 A                       | 480 V- 83A  | 480 V - 48 A                 |
| <b>Operating Temperature*</b>     | -25°C to +40°C                     | -40°C to +40°C   | -25°C to +40°C<br>-25°C to +45°C ** | -25°C to +40°C                                    | -25°C to +40°C               |
| <b>Size (wxdxh)</b>               | 845 x 1300 x 1210 mm               | 845 x 1300 x 1210 mm<br>845 x 1300 x 1360 mm ***       | 845 x 1300 x 1210 mm                | 845 x 1295 x 985 mm                               | 845 x 1295 x 985 mm          |
| <b>Weight</b>                     | 620 kg                             | 480 kg   | 430 kg                              | 310 kg  | 310 kg                       |

\* Extended temperature range available upon request,\*\* applies to 480 V, 60 Hz, \*\*\* applies to 100 kV model

### SUCCESS STORY

**GE's Environmental Control Systems and GE Power Service in Malaysia supplied, installed and commissioned the GE high frequency transformers, SIR 4, and control units, EPIC III, at KAPAR Energy Ventures site.**

This is a 500 MW coal fired boiler located 50 km west of Kuala Lumpur. With our powerful high frequency transformers and intelligent control units, we were able to reduce particulate emissions by 50%, compared to the level before the installation and this was done with no other investment in the flue gas cleaning system! In addition the GE Process monitoring system ProMo was installed enabling remote monitoring and adjusting of the flue gas handling system parameters for even higher efficiency.

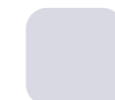
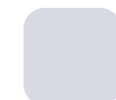



## OVERVIEW

# CARBON CAPTURE SYSTEMS

As a leader in the development of both clean coal technologies and air quality control systems, GE is at the forefront in the development of carbon capture technologies (CCS). With an intensive research and development program, we have designed and constructed CO<sub>2</sub> Capture projects around the world.



As a leader in the development of both cleaner coal technologies and air quality control systems, GE is at the forefront in the development of carbon capture technologies. With an intensive research and development program, we have designed and constructed 13 CO<sub>2</sub> capture solutions (CCS) demonstration projects around the world, and these technologies are ready for large-scale implementation.

Given the variety of plant types and fuel combinations in operation today, GE's portfolio of technologies provides our customers with solutions that take into account many variables, including installation costs, overall plant efficiencies, and operation and maintenance costs. Our CCS technologies offer both post-combustion and oxy-combustion solutions for applications covering new build plants and the existing installed base. Additionally, our post combustion technologies can be scaled down for industrial flue gas from sources such as steel mills, cement factories, refineries and chemical plants. We are also developing second-generation technologies such as regenerative calcium cycle (RCC) and chemical looping combustion (CLC).

### What we offer

Our CCS services range from concept engineering and feasibility studies to plant commissioning. Our full scope of solutions includes design, equipment supply, installation, power block system integration, CO<sub>2</sub> capture and processing equipment, and the full power plant. We make sure our customers have everything they need, including cost control, quality control, health and safety and O&M training.

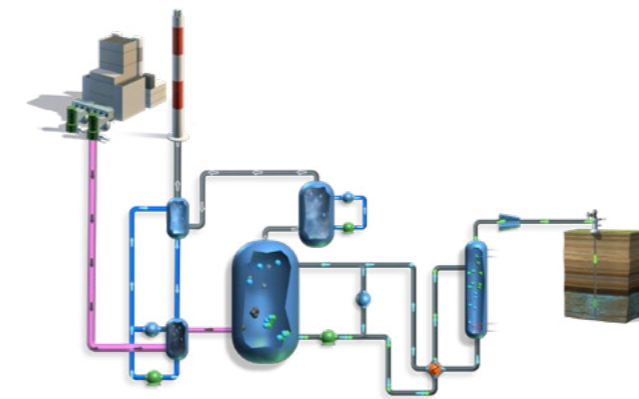

### Post-combustion (New + retrofit)

- Flue gas is conditioned
- CO<sub>2</sub> is chemically absorbed to a solvent (advanced amines or chilled ammonia).
- CO<sub>2</sub> is released by raising the temperatures and allowing the solvent to be recycled
- CO<sub>2</sub> product is dried and compressed and sent for storage or utilization

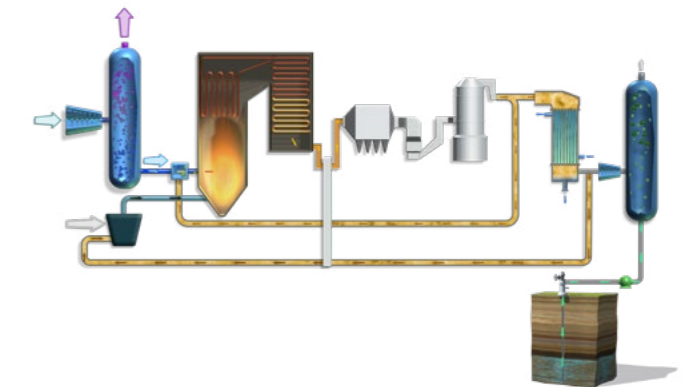

### Oxy-combustion (New + retrofit)

- Fuel is burned in a mixture of oxygen and re-circulated flue gas. Due to the absence of nitrogen, the resulting flue gas is rich in CO<sub>2</sub>.
- After water condensing and further purification, CO<sub>2</sub> is compressed and sent for storage or utilization.

| Parameters   | Post-combustion (AAP & CAP)                                   | Oxy-combustion - Gas processing             |                                   |
|--|---|---|-----------------------------------|
| <b>Flue gas inlet conditions</b>                           | <b>Temperature [°C]</b>                                       | 30-100                                      | 20 - 100                          |
|  | <b>Pressure [bara]</b>  | 1   | 1                                 |
|  | <b>Flow Rate (t/h)</b>  | 70 -1.150                                   | Up to 875                         |
|  | <b>CO<sub>2</sub> Vol (% dry basis)</b>                       | 4 - 15                                      | 70 - 95                           |
|  | <b>H<sub>2</sub>O (%)</b>                                     | 5-30  | 2-25                              |
|  | <b>N<sub>2</sub> Vol (% dry basis)</b>                        | 70-90                                       | 2-5                               |
|  | <b>O<sub>2</sub> Vol (% dry basis)</b>                        | 3-10  | 20 - 50                           |
| <b>CO<sub>2</sub> capture rate (%)</b>                     | up to 90  | 90  |                                   |
| <b>Utilities consumption</b>                               | <b>Specific steam consumption [GJ/tCO<sub>2</sub>]</b>        | 2.2-3.0                                     |                                   |
|  | <b>Specific electricity consumption [kWh/tCO<sub>2</sub>]</b> | 120-150                                     | 122-160                           |
|  | <b>Solvent make-up rate [kg/tCO<sub>2</sub>]</b>              | 0.2-0.4                                     |                                   |
|  | <b>Cooling water need [t/tCO<sub>2</sub>]</b>                 | 70-90 @ DT=10°C                             | 32-43                             |
|  | <b>Chemicals make-up rate [kg/tCO<sub>2</sub>]</b>            | Depending strongly on feed gas compositions | Depending on feed gas composition |
| <b>CO<sub>2</sub> Product Specification and Conditions</b> | <b>Temperature [°C]</b>                                       | 20-50                                       | -20 - 50                          |
|  | <b>Pressure [bara]</b>  | 1-200                                       | 19 - 200                          |
|  | <b>Flow Rate (t/h)</b>  | 12.5-230                                    | Up to 276                         |
|  | <b>CO<sub>2</sub> Vol (% dry basis)</b>                       | >99.5-99.9                                  | > 99                              |
|  | <b>H<sub>2</sub>O (%)</b>                                     | <10 -500 (depending on targeted use)        | < 10                              |



Integrated GE approach, providing both technical and economical benefits

# Smarter. Cleaner. Steam Power.

[www.gepower.com/steam](http://www.gepower.com/steam)

# Power Services Catalog

[https://content.gepower.com/  
pw-hq/2018PSCatalog](https://content.gepower.com/pw-hq/2018PSCatalog)



When it comes to our customers' most pressing questions, our answer is YES. It's a small but meaningful word that ensures the power is on for everyone, everywhere. At GE, we are transforming the future of steam power, creating extraordinary outcomes for tomorrow and beyond.

**This is the Power of Yes.**

Visit us to learn more  
[gepower.com/powerofyes](http://gepower.com/powerofyes)



