



NEW ZEALAND

EDICT OF GOVERNMENT

In order to promote public education and public safety, equal justice for all, a better informed citizenry, the rule of law, world trade and world peace, this legal document is hereby made available on a noncommercial basis, as it is the right of all humans to know and speak the laws that govern them.

AS-NZS 3012 (2010) (English): Electrical
installations - Construction and demolition sites
[By Authority of New Zealand Electricity (Safety)
Regulations 2010 (SR 2010/36)]

*We will sell to no man,
we will not deny or defer to any man either justice or right.*

Magna Carta—Tūtohingā Nui

*Kore rawa e hoko ki te tangata, e kore e whakakāhoretia,
e tautuku rānei te tangata ki te ture, tika ranei.*



BLANK PAGE



AS/NZS 3012:2010



Australian/New Zealand Standard™
Electrical installations—Construction



AS/NZS 3012:2010

This Joint Australian/New Zealand Standard was prepared by Joint Technical Committee EL-001, Wiring Rules. It was approved on behalf of the Council of Standards Australia on 6 May 2010 and on behalf of the Council of Standards New Zealand on 4 June 2010.

This Standard was published on 22 June 2010.

The following are represented on Committee EL-001:

Association of Consulting Engineers Australia
Australian Building Codes Board
Australian Electrical and Electronic Manufacturers Association
Canterbury Manufacturers Association New Zealand
Communications, Electrical and Plumbing Union
Consumers' Federation of Australia
Electrical Contractors Association of New Zealand
Electrical Regulatory Authorities Council
Electrical Safety Organisation (New Zealand)
Electrical and Communications Association (Queensland)
ElectroComms & Energy Utilities Industries Skills Council
Energy Networks Association
Engineers Australia
Institute of Electrical Inspectors
Ministry of Economic Development (New Zealand)
National Electrical and Communications Association
New Zealand Council of Elders
New Zealand Electrical Institute
Telstra Corporation Limited
WorkSafe Victoria

Additional Interests:

Australian Industry Group
Department of Justice (Tasmania)
Housing Industry Association
Master Builders Association of Australia
WorkCover New South Wales

Keeping Standards up-to-date

Standards are living documents which reflect progress in science, technology and systems. To maintain their currency, all Standards are periodically reviewed, and new editions are published. Between editions, amendments may be issued. Standards may also be withdrawn. It is important that readers assure themselves they are using a current Standard, which should include any amendments which may have been published since the Standard was purchased.

Detailed information about joint Australian/New Zealand Standards can be found by visiting the Standards Web Shop at www.saiglobal.com.au or Standards New Zealand web site at www.standards.co.nz and looking up the relevant Standard in the on-line catalogue.

For more frequent listings or notification of revisions, amendments and withdrawals, Standards Australia and Standards New Zealand offer a number of update options. For information about these services, users should contact their respective national Standards organization.

We also welcome suggestions for improvement in our Standards, and especially encourage readers to notify us immediately of any apparent inaccuracies or ambiguities. Please address your comments to the Chief Executive of either Standards Australia or Standards New Zealand at the address shown on the back cover.

This Standard was issued in draft form for comment as DR 09065.

Australian/New Zealand Standard™

**Electrical installations—Construction
and demolition sites**

Originated in Australia as AS 3012—1990.
Previous edition AS/NZS 3012:2003.
Fourth edition 2010.

COPYRIGHT

© Standards Australia/Standards New Zealand

All rights are reserved. No part of this work may be reproduced or copied in any form or by any means, electronic or mechanical, including photocopying, without the written permission of the publisher.

Jointly published by Standards Australia, GPO Box 476, Sydney, NSW 2001 and Standards New Zealand, Private Bag 2439, Wellington 6140

ISBN 978 0 7337 9622 7

PREFACE

This Standard was prepared by the Joint Standards Australia/Standards New Zealand Committee EL-001, Wiring Rules, to supersede AS/NZS 3012:2003.

The objective of this Standard is to establish sound practices for the safe use of electricity at construction and demolition sites. It is to be used in conjunction with AS/NZS 3000, *Electrical installations (known as the Australian/New Zealand Wiring Rules)*.

The main differences between this Standard and AS/NZS 3012:2003 include the following:

- (a) Requirements of this Standard have been updated to reflect changes in the latest edition of AS/NZS 3000.
- (b) A definition has been added for 'assembly for construction sites' (Clause 1.4.6).
- (c) A definition has been added for 'auxiliary socket-outlet panel' (Clause 1.4.7).
- (d) A definition has been added for 'competent person' (Clause 1.4.9).
- (e) The definition of construction wiring has been revised (Clause 1.4.11).
- (f) Requirements for appliances, luminaires and electrical equipment supplied by final sub-circuits of permanent installation wiring have been clarified (Clause 2.1.2).
- (g) Requirements for the use of inverters on construction and demolition sites have been revised (Clause 2.4.6.4).
- (h) Requirements for the assessment of risk for permanent wiring located where construction or demolition work may be carried out have been added (Clause 2.4.6.5).
- (i) Requirements for protection against mechanical damage for construction wiring have been added (Clause 2.4.6.5).
- (j) Requirements for double-pole switching of socket-outlets have been clarified (Clause 2.4.7).
- (k) Requirements for portable socket-outlet assemblies have been revised (Clause 2.6.10).
- (l) Requirements for auxiliary socket-outlet panels have been added. (Clause 2.6.11).
- (m) The use of electrical portable outlet devices (EPODs) to AS/NZS 3105 has been prohibited (Clause 2.6.12).
- (n) Requirements for supply to transportable structures have been revised (Clause 2.9).
- (o) Testing and inspection of fixed and portable electrical equipment has been clarified. (See Section 3.)
- (p) Referenced documents in Appendix A have been updated.
- (q) Variation added to Appendix B for the use of auxiliary socket-outlet panels in domestic housing construction.
- (r) Appendix D updated with current Regulatory contact information.
- (s) Appendix G added to provide guidance on the verification (inspection and testing) of generators and inverters with RCD protection.
- (t) Appendix H added to provide guidance on the arrangement of construction equipment.
- (u) Appendix I added to provide a verification form for use in New Zealand.
- (v) Appendix J added to provide information for supply systems for construction and demolition sites.

- (w) Appendix K added to provide information for alternative supply systems for construction and demolition sites.

Any requirement that is applicable only in Australia only or New Zealand only is indicated by the symbol **A** or **NZ** in the right margin.

Statements expressed in mandatory terms in notes to figures are deemed to be requirements of this Standard.

The terms 'normative' and 'informative' have been used in this Standard to define the application of the appendix to which they apply. A 'normative' appendix is an integral part of a Standard, whereas an 'informative' appendix is for information and guidance.

CONTENTS

	<i>Page</i>
SECTION 1 SCOPE AND GENERAL	
1.1 SCOPE	5
1.2 APPLICATION	6
1.3 REFERENCED DOCUMENTS	6
1.4 DEFINITIONS	6
SECTION 2 INSTALLATION	
2.1 SUPPLY	9
2.2 MAXIMUM DEMAND.....	10
2.3 SWITCHBOARDS INSTALLED FOR THE PURPOSE OF CONSTRUCTION AND DEMOLITION	10
2.4 CONTROL AND PROTECTION.....	11
2.5 CONSTRUCTION WIRING	18
2.6 FLEXIBLE CORDS, CORD EXTENSION SETS, FLEXIBLE CABLES AND ACCESSORIES.....	20
2.7 LIGHTING AND LUMINAIRES.....	25
2.8 LIFT SHAFTS.....	26
2.9 TRANSPORTABLE STRUCTURES.....	27
SECTION 3 VERIFICATION (INSPECTION AND TESTING)	
3.1 APPLICATION	29
3.2 FREQUENCY OF VERIFICATION (INSPECTION AND TESTING)	29
3.3 PERSONNEL	29
3.4 CONSTRUCTION WIRING AND TRANSPORTABLE STRUCTURES	30
3.5 RCDS	30
3.6 OTHER ELECTRICAL EQUIPMENT ON SITE.....	30
3.7 CONNECTION BETWEEN GENERATOR WINDINGS, FRAME AND EQUIPOTENTIAL BONDING SYSTEM.....	31
3.8 ACTIONS RESULTING FROM INSPECTION AND TEST.....	31
3.9 PORTABLE GENERATOR SETS AND INVERTERS	33
3.10 DOCUMENTATION.....	33
APPENDICES	
A LIST OF REFERENCED DOCUMENTS	34
B ELECTRICAL INSTALLATIONS IN THE DOMESTIC HOUSING CONSTRUCTION INDUSTRY	36
C CLASSIFICATION OF BUILDINGS AND STRUCTURES	37
D REGULATORY APPLICATION ON CONSTRUCTION AND DEMOLITION SITES.....	39
E MARKING OF SWITCHBOARDS TO INDICATE THE PRESENCE OF LIVE PARTS.....	46
F RECOMMENDED COLOURS FOR TAGS ON TESTED EQUIPMENT	47
G ELECTRICAL VERIFICATION OF GENERATORS WITH RCD PROTECTION TO AS/NZS 3012 AND AS/NZS 3760.....	48
H ELECTRICAL VERIFICATION OF PORTABLE INVERTERS	49
I NEW ZEALAND ONLY VERIFICATION FORM FOR CONSTRUCTION AND DEMOLITION SITES	52
J GUIDE TO ARRANGEMENT OF SWITCHBOARDS, CONSTRUCTION WIRING AND EQUIPMENT	53
K ALTERNATIVE SUPPLY SYSTEM FOR CONSTRUCTION AND DEMOLITION SITES	54

STANDARDS AUSTRALIA/STANDARDS NEW ZEALAND

Australian/New Zealand Standard**Electrical installations—Construction and demolition sites**

SECTION 1 SCOPE AND GENERAL

1.1 SCOPE

This Standard sets out minimum requirements for the design, construction and testing of electrical installations that supply electricity to appliances and equipment on construction and demolition sites, and for the in-service testing of portable, transportable and fixed electrical equipment used on construction and demolition sites.

For a single domestic residence intended to be occupied as a residential housing unit, or, adjoining units each with a separate exterior entry and intended to be occupied as residential housing units, the requirements of this Standard are varied as detailed in Appendix B.

NOTE: The Building Code of Australia (BCA) classification of building and structures is given in Appendix C.

The requirements are intended to protect persons, livestock and property from electric shock, fire and physical injury hazards that may arise from an electrical installation that is used with reasonable care and with due regard to the intended purpose of the electrical installation.

NOTE: For requirements and recommendations regarding safe working on or near electrical equipment and installations, refer to AS/NZS 4836 and to Codes of Practice or other guidance issued by the regulatory authorities.

This Standard applies to electrical installations associated with construction and demolition sites which include—

- (a) building work, excavation work, compressed air work and diving work;
- (b) parts of buildings that undergo structural alterations, such as extensions, major repairs or demolition, to the extent that the work necessitates the provision of a temporary electrical installation;
- (c) work on or in connection with the construction or maintenance of roads, airfields or airstrips, civil engineering works or bridges, or of the permanent way of a railway or tramway;
- (d) dredging or salvaging work;
- (e) the laying, lining or maintenance of pipes or cables;
- (f) earthmoving work carried out with equipment requiring the use of other than manual power;
- (g) any work in which explosives are used;
- (h) site offices, cloakrooms, meeting rooms, dormitories, canteens, toilets, appliances and other facilities provided during any work referred to in (a) to (g); and
- (i) land clearing in preparation for any work referred to in (a) to (g).

1.2 APPLICATION

Electrical installations on construction and demolition sites shall be carried out in accordance with AS/NZS 3000, except as varied herein, and with the applicable additional requirements of this Standard.

This Standard shall be read and used in conjunction with the requirements of local Electricity Safety and Occupational Health and Safety legislation and guidelines.

NOTE: Appendix D gives details of relevant authorities in Australia.

1.3 REFERENCED DOCUMENTS

Documents referred to in this Standard are listed in Appendix A.

1.4 DEFINITIONS

For the purpose of this Standard the definitions given in AS/NZS 3000 and those below apply.

1.4.1 Appliance

A consuming device, other than a lamp, in which electricity is converted into heat, motion, or any other form of energy, or is substantially changed in its electrical character.

1.4.2 Appliance, fixed

An appliance that is fastened to a support or otherwise secured in a specific location.

1.4.3 Appliance, hand-held

A portable appliance intended to be held in the hand during normal use, the motor, if any, forming an integral part of the appliance.

1.4.4 Appliance, portable

Either an appliance that is moved while in operation or an appliance that can easily be moved from one place to another while connected to the supply.

1.4.5 Appliance, stationary

Either a fixed appliance or an appliance having a mass exceeding 18 kg and not provided with a carrying handle.

1.4.6 Assembly for Construction Sites (ACS)

Switchboards complying with AS/NZS 3439.4 and the requirements of Clause 2.3.2.

NOTE: Further information is given in Appendix K.

1.4.7 Auxiliary socket-outlet panel

A socket-outlet assembly, supplied by a fixed-wired dedicated final sub-circuit of construction wiring. (See Clause 2.6.11).

1.4.8 Cable, flexible

A cable, the conductors, insulation and covering of which afford flexibility.

1.4.9 Competent person

A person, who has acquired, through training, qualification or experience or a combination of these, the knowledge and skill enabling that person to perform the required task correctly.

1.4.10 Construction and demolition site

A site where work in accordance with Clause 1.1 is carried out.

1.4.11 Construction-wiring (Construction and demolition wiring)

A system of wiring that is installed to provide electrical supply for construction and demolition work and is not intended to form part of the permanent electrical installation.

The term includes—

- (a) consumers mains and sub-mains supplying site switchboards; and
- (b) sub-mains to site facilities in which electricity is used, such as sheds, amenities or transportable structures; and
- (c) final sub-circuits connected at circuit-breakers on a site switchboard, supplying plant, construction equipment such as temporary construction lighting, auxiliary socket-outlet panels, hoists, and personnel lifts.

Construction wiring does not include flexible cords or flexible cables used to connect appliances or luminaires to a socket-outlet, but does include flexible cords or flexible cables used for items (a), (b) or (c) above.

NOTE: Construction wiring and equipment is normally intended to be removed at the completion of construction work and is not intended to form part of the permanent installation. This does not exclude parts of the permanent installation being used to support or supply construction wiring provided it satisfies the relevant requirements of this Standard. Unused conductors must be treated so they comply with the 'Voltage in unused conductors' section of AS/NZS 3000.

1.4.12 Cord, flexible

A flexible cable, no wire of which exceeds 0.31 mm diameter and no conductor of which exceeds 4 mm² cross-sectional area, and having not more than five cores.

1.4.13 Detachable connection

The connection of electrical equipment to a source of supply by means of a plug and socket.

1.4.14 Direct connection

The connection of electrical equipment directly to the source conductors by means of a terminal, stud or other such arrangements.

1.4.15 Double-pole switch

A switch that operates in both poles substantially at the same time.

NOTE: For single phase circuits, all live (active and neutral) conductors are switched.

1.4.16 Electrical equipment

Wiring systems, switchgear, controlgear, accessories, appliances, luminaires and fittings used for such purposes as generation, conversion, storage, transmission, distribution or utilization of electrical energy.

1.4.17 Fixed equipment

Electrical equipment that is fastened to a support or otherwise secured in a specific location.

1.4.18 Inverter

Device that uses semi-conductor devices to transfer power between a d.c. source and an a.c. load.

1.4.19 Isolated inverter

Inverter with protection by electrical separation, using double insulation or reinforced insulation between input circuits and output circuits and between output circuits and accessible conductive parts.

1.4.20 Permanent wiring

Wiring that forms part of the permanent electrical installation of a building or site.

1.4.21 Portable socket-outlet assembly (PSOA)

An assembly, other than a cord extension set, having a heavy duty sheathed flexible cord, one or more socket-outlets, an overload protection device, a residual current device and a plug intended for connection to a low-voltage socket-outlet. It may also incorporate a reeling or coiling arrangement.

NOTE: As a PSOA is a type of portable RCD (PRCD), it is a declared article and must comply with the relevant requirements of AS/NZS 3190 and have regulatory approval.

1.4.22 Qualified person

A qualified person for electrical installation work is a suitably licensed electrician in Australia or a licensed electrical worker in New Zealand.

1.4.23 RCD protected inverter (RCDP inverter)

Inverter that is fitted with a residual current device (RCD) in the output circuit and with equipotential bonding of the earthing terminal of the a.c. output connector with input circuits and the accessible conductive parts and with polarized output circuits achieved by connecting of the earthing terminal of the a.c. output connector to either the—

- (a) upstream side of the RCD on the pole that is connected to the neutral terminal of the a.c. output connector; or
- (b) centre tap of the output circuit supply on the upstream side of the RCD.

NOTES:

- 1 This type of inverter may have accessible conductive parts that are separated from the output circuits by double or reinforced insulation—these parts do not need to be bonded.
- 2 Where the d.c. input circuit is such that the input terminals are effectively connected together by a low impedance (e.g. internal impedance of a secondary battery), equipotential bonding of a single input terminal is considered to satisfy the requirement for all such input terminals.

1.4.24 Residual current device (RCD)

A device intended to isolate supply to protected circuits, socket-outlets or electrical equipment in the event of a current flow to earth that exceeds a predetermined value.

NOTE: RCDs are classified in AS/NZS 3190, AS/NZS 61008.1 and AS/NZS 61009.1.

1.4.25 Shall

Indicates a statement is mandatory.

1.4.26 Should

Indicates a recommendation.

1.4.27 Transportable structures

The term transportable structure includes both vehicles and structures with or without wheels that can readily be moved from one site to another either under their own motive power or by some other means.

NOTE: Includes temporary site offices, cloakrooms, meeting offices, dormitories, canteens, toilets, workshops, site huts or other facilities provided on construction and demolition sites.

SECTION 2 INSTALLATION

2.1 SUPPLY

2.1.1 Construction wiring

Construction wiring shall be supplied from—

- (a) an electricity distributor's main; or
- (b) an existing switchboard in the permanent installation of the premises; or
- (c) a low voltage generator complying with the principles of AS 2790, which shall be installed in accordance with AS/NZS 3010; or
- (d) an inverter complying with the requirements of AS/NZS 4763(Int).

2.1.2 Appliances, luminaires and electrical equipment

All appliances, luminaires and other electrical equipment shall be supplied from—

- (a) a final sub-circuit of the construction wiring, provided with overcurrent protection in accordance with Clause 2.4.5.2 and additional protection in accordance with Clause 2.4.6.1; or
- (b) permanent wiring, provided with additional protection in accordance with Clause 2.4.6.2; or
- (c) a stand-alone power source, provided, where necessary, with additional protection in accordance with Clause 2.4.6.3 or Clause 2.4.6.4, as applicable.

2.1.3 Identification of source of supply

Where there is more than one switchboard on site, each directly connected appliance shall be legibly and indelibly marked to identify the switchboard at which its final sub-circuit originates (see also Clause 2.3.2.1(f)).

Exception: This requirement does not apply to appliances connected by means of a plug and socket or to luminaires.

2.1.4 Connection devices

All plugs, socket-outlets and appliance couplers shall comply with AS/NZS 3112, AS/NZS 3123 or IEC 60309 as applicable and shall have an IP rating appropriate for the environment. Devices for interconnection of sub-mains shall be designed to prevent inadvertent disconnection under load.

NOTE: Further guidance on IP ratings is provided in AS/NZS 3000.

2.1.5 Polarization

All plugs, fixed socket-outlets and cord extension sockets of single and multiphase shall be connected so the polarity of the single phase complies with the requirements of AS/NZS 3000 and the phase sequence of multiphase is the same for all fixed socket-outlets and cord extension sets on a construction or demolition site.

2.1.6 Separate circuit requirements

One or more separate circuits shall be provided for each of the specific types of electrical equipment listed below:

- (a) Socket-outlets.
- (b) Lighting points.
- (c) Permanently connected welding equipment.

- (d) Other specific electrical equipment as required by AS/NZS 3000.
- (e) Transportable structures (see also Clause 2.9 and AS/NZS 3001).
- (f) Auxiliary socket-outlet panels.

2.2 MAXIMUM DEMAND

The maximum demand of mains and sub-mains of construction wiring shall be determined by one of the methods specified in AS/NZS 3000.

2.3 SWITCHBOARDS INSTALLED FOR THE PURPOSE OF CONSTRUCTION AND DEMOLITION

2.3.1 Location

2.3.1.1 General

All switchboards shall be installed in accordance with AS/NZS 3000.

All switchboards shall be readily accessible and shall be protected from damage during the course of the construction or demolition work.

Every switchboard or part of a switchboard that is supplied from a separate source of supply shall be legibly and indelibly marked to identify the source of supply from which it originates.

NOTE: If the source of supply is a generating set, a unique identifier such as the plant number of the generating set satisfies this requirement.

2.3.1.2 Distribution boards

In multi-level buildings, distribution boards shall be positioned in a manner that eliminates the need for flexible cords or cables to be run between levels.

Exception: This requirement need not apply to work in lift shafts, stairwells, service shafts, formwork, external staging or sub-mains of construction wiring or a single domestic residence as detailed in Appendix B.

2.3.2 Switchboard construction

2.3.2.1 General requirements

All switchboards including those described in Clause 2.3.2.2 shall be constructed to comply with the following requirements:

- (a) Robust construction and materials to withstand mechanical damage from environment or other external influences that may be expected at the location.
- (b) The enclosure shall have a degree of protection appropriate for the environment in which it is installed subject to a minimum degree of protection of IP23.
- (c) Live parts shall be effectively protected at all times against contact by persons operating equipment located on the switchboard, including the connection or disconnection of plugs to socket-outlets.
- (d) Where the switchboard is provided with a socket-outlet, means to prevent strain at connections or terminations, such as an insulated or covered tie bar, shall be provided for the anchorage of external cables and flexible cords.
- (e) Where provided with a door or lid to maintain degree of protection, the door or lid shall—
 - (i) require the use of a tool for removal; and
 - (ii) be fitted with a facility for locking; and
 - (iii) be fitted with a means of retention in the open position; and

- (iv) not damage leads and allow the safe entry of leads if the switchboard is provided with socket-outlets. A clearly visible and legible sign shall be fixed on the external surface. For example words to the effect of 'KEEP CLOSED—RUN ALL LEADS THROUGH BOTTOM'; and
- (v) be kept closed except when access is required.
- (f) Where there is more than one switchboard on the site, marking shall be provided, by means of numbers, letters or both, to distinguish one switchboard from another.
- (g) Switchboards shall be marked in accordance with Appendix E to indicate the presence of live parts.

NOTE: Some Regulatory Jurisdictions require provision to be made on construction and demolition switchboards supplying more than one final sub-circuit, for the fitting of a lockable or sealable cover over circuit-breakers and RCDs associated with these circuits or other devices that would control the resetting of circuit-breakers and RCDs, but does not prevent access to isolation switches.

2.3.2.2 Alternative switchboard construction

Alternative switchboards shall comply with AS/NZS 3439.4 and the additional requirements of Appendix K.

NOTE: Switchboards complying with AS/NZS 3439.4 are deemed to comply with 2.3.2.1(a), (b) and (c).

2.3.3 Mounting of switchboards

Switchboards shall be securely attached to a pole, post, wall, floor or other structure unless of a stable, freestanding design that takes into account any external forces that may be exerted on the switchboard, for example, by flexible cords.

2.3.4 Socket-outlets

Socket-outlets provided on switchboards for the connection of portable appliances and other electrical equipment shall be rated at not less than 10 A.

NOTE: Where required all switchboards should be fitted with at least one 15 A or one 16 A, single phase, socket-outlet. For example, such socket-outlets may be required to supply welders and floor sanders.

2.3.5 Support of cables entering switchboards

At each switchboard, a fixed secure and stable means shall be provided to prevent mechanical damage to flexible cords and cables and prevent the transfer of mechanical strain to the cable connections (see Clause 2.5.3).

NOTE: An example of such a means is to support flexible cords and cables above the floor or ground on stands, cross-arms or similar, covered with material that is non-conducting.

2.3.6 Guide to arrangement of switchboards, wiring and equipment

Appendix J provides a diagram for guidance on the arrangement of construction systems. Requirements on safety services are included.

2.4 CONTROL AND PROTECTION

2.4.1 Control

Each switchboard shall be provided with one isolating switch marked in accordance with Clause 2.4.3 and complying with the requirements for isolating switches in AS/NZS 3000. This switch shall interrupt supply to all final sub-circuits and sub-mains originating from the switchboard, including circuits supplying socket-outlets mounted on the switchboard.

Exceptions:

- (a) One additional switch may be provided, marked in accordance with Clause 2.4.3, for the control of all final sub-circuits intended to operate out of normal working hours.
- (b) Additional switches controlling safety services, where required by AS/NZS 3000, shall be provided and clearly identified, all in accordance with AS/NZS 3000.

NOTE: Consideration should be given to generator supplies to ensure that the isolating switch provides isolation from all incoming supplies

2.4.2 Securing of isolating switch

Isolating switches shall be provided with a means to prevent electrical equipment from being inadvertently energised. The means of isolation shall be such that a deliberate action in addition to the normal method of operation is required to energise the circuit.

The following methods are considered to satisfy this requirement—

- (a) provision for the fitting of a padlock; or
- (b) location within a lockable space or enclosure.

NOTE: Warning tags or notices alone are not acceptable, but may be used in conjunction with (a) or (b) above.

Short-circuiting and earthing should be used only as a supplementary measure.

2.4.3 Marking of isolating switches

All isolating switches controlling the portions of the installation included in Clause 2.4.1 shall be marked as required by AS/NZS 3000 and as follows:

‘MAIN SWITCH’—on main switchboards.

‘DISTRIBUTION BOARD ISOLATING SWITCH’—on distribution boards.

‘ISOLATING SWITCH AFTER HOURS SUPPLY—DO NOT SWITCH OFF’—for circuits supplying electrical equipment operating out of normal working hours.

Main switches for safety services shall be identified in accordance with AS/NZS 3000.

2.4.4 Size of marking

Letters used for marking referred to in Clause 2.4.3 shall not be less than 6 mm high and of a contrasting colour to the background material.

2.4.5 Overload protection**2.4.5.1 Sub-mains**

Devices for protection against overload and short-circuit currents in sub-mains shall be one of the following types:

- (a) Enclosed fuse-links complying with the appropriate Standard(s) in the AS 60269 series and be rated IP2X.
- (b) Miniature overcurrent circuit-breakers complying with AS 3111 and AS/NZS 60898.1.
- (c) Moulded-case circuit-breakers complying with AS 60947.2.
- (d) Circuit-breakers complying with AS 60947.2.

2.4.5.2 Final sub-circuits

Devices for protection against overload and short-circuit currents in final sub-circuits shall be one of the following types:

- (a) Miniature overcurrent circuit-breakers complying with AS 3111 and AS/NZS 60898.1.

- (b) Moulded-case circuit-breakers complying with AS 60947.2.
- (c) Where supplying fixed appliances rated at 50 A per phase or greater, enclosed fuse-links complying with the AS 60269 series of Standards and having a degree of protection of at least IP2X when the removal carrier is inserted or removed.

2.4.6 Additional protection—basic protection (protection against direct contact) and fault protection (protection against indirect contact)

2.4.6.1 Final sub-circuits of construction wiring

All final sub-circuits of construction wiring shall be protected at the switchboard where the final sub-circuits originate by residual current devices, with a maximum rated residual current of 30 mA, that operate in all live (active and neutral) conductors. The final sub-circuits shall be arranged—

- (a) where the number of RCDs installed exceeds one; or
- (b) where more than one lighting circuit is installed,

the lighting circuits shall be distributed between RCDs.

NOTE: This arrangement is intended to minimize the impact of the operation of a single RCD.

Exceptions: Additional protection by an RCD need not apply to any of the following types of final sub-circuit:

- (i) *Final sub-circuits supplying electrical equipment where safe mechanical operation is at risk, e.g. electric cranes or personnel lifts.*
- (ii) *Final sub-circuits where all appliances, luminaires and other electrical equipment are supplied from a directly connected SELV or PELV source in accordance with the requirements of AS/NZS 3000 for extra low-voltage supply.*

NOTE: A 110 V centre-tapped transformer to the requirements of AS/NZS 61558.2.23 is deemed to be a PELV source of supply but any circuits connected to the transformer must be fitted with plugs and sockets that are not interchangeable with other systems of supply (see AS/NZS 3000).

- (iii) *Final sub-circuits where all appliances, luminaires and other electrical equipment are supplied from a directly connected safety isolating transformer complying with AS/NZS 61558.2.23, supplying a separated circuit for electrical equipment installed in accordance with the electrical separation requirements of AS/NZS 3000 and with each winding supplying not more than one item of Class I (earthed conductive parts) electrical equipment.*

NOTE: This description includes a single winding supplying one or more items of Class II (double insulated) electrical equipment and a single winding supplying one item of Class I (earthed conductive parts) electrical equipment plus one or more items of Class II (double insulated) electrical equipment.

2.4.6.2 Appliances, luminaires and other electrical equipment supplied by final sub-circuits of permanent installation wiring

Where appliances, luminaires and other electrical equipment are supplied from a final sub-circuit of the permanent installation, the equipment shall be protected by an RCD with a maximum rated residual current of 30 mA located in accordance with one of the following:

- (a) At the switchboard at the origin of the final sub-circuit.
- (b) Incorporated into the socket-outlet supplying the electrical equipment.
- (c) Incorporated into a portable socket-outlet assembly complying with Clause 2.6.10, arranged for connection to the supply socket-outlet either directly or by means of a plug and flexible cord of maximum length 2 m.

NOTE: This provision allows for construction or demolition work in existing premises that involves the use of plug-in equipment, such as tools and task lighting, to be carried out using existing socket-outlets that are in the vicinity of the construction work. When the construction work is more significant in terms of duration, scale or equipment, arrangements should be made to have construction wiring and equipment installed that conforms to the requirements of this Standard.

2.4.6.3 *Electrical equipment supplied by low-voltage generators*

LV generators complying with the principles of AS 2790 shall be connected in accordance with AS/NZS 3010 and as follows:

NOTE: LV is any voltage exceeding 50 V a.c. or 120 V d.c. but not exceeding 1000 V a.c. or 1500 V d.c. For example, welding generators with auxiliary circuits supplying 115 V a.c. that do not originate from an isolated winding is required to be RCD protected as per Clause 2.4.6.3(c).

- (a) Where a site switchboard is supplied directly by a generator all sub-mains and final sub-circuits originating at that switchboard shall be protected in accordance with Clauses 2.4.5 and 2.4.6.1 as illustrated in Figure 2.1.
- (b) Isolated winding generators, connected in accordance with Figure 2.2, shall only be used on construction and demolition sites to supply a separated circuit for electrical equipment, installed in accordance with the electrical separation requirements of AS/NZS 3000. Each winding shall supply not more than one item of Class I (earthed conductive parts) electrical equipment.

NOTES:

- 1 One or more items of Class II (double insulated) electrical equipment may be connected to an isolated winding generator.
- 2 Portable RCDs will not operate as there is no neutral to earth connection upstream of the RCD.
- 3 In some jurisdictions, the use of isolated winding generators is not permitted on construction and demolition sites.
- 4 The 2 pole switching shown in Figure 2.2 is required as both conductors are considered to be live—neither is earthed in normal operation.
- 5 The connection of the generating set bonding system to the general mass of earth through an earth electrode is not required or recommended as there is double insulation from the live parts to the frame.
- 6 Only one Class I item (one is based on probability) is allowed as the first fault from a live part to earth makes it a non-isolated system.

- (c) Generators providing electrical supply via permanently connected RCDs with maximum rated residual current of 30 mA, operating in all live (active and neutral) conductors, and connected as per Figure 2.3, may be used to supply multiple items of equipment.

NOTES:

- 1 The RCD protected system allows the use of multiple Class I (metal frame with a bonding conductor) items as the first fault causes a residual current device to trip.
- 2 The connection of the generating set bonding system to the general mass of earth through an earth electrode is not required or recommended. At 240 V a current of 30 mA will not flow if the fault path resistance exceeds 8 k Ω . Without an earth electrode the current is reduced, but an RCD will operate at 30 mA irrespective of the arrangement. The protection required is given without an electrode. It is considered the possible fault current should be as low as practicable and hence an electrode should NOT be used.
- 3 This principle does not apply to the MEN system where the neutral is earthed at the source and at multiple points. (See Figure 2.1).
- 4 The following examples of fault current paths and currents (see Figure 2.3) have been considered when deciding an earth electrode is not required:

- (a) A fault between live parts and the equipotentially bonded exposed conductive parts such as the frame of a Class I appliance or from the internal live parts of Class II appliances to the bonding system.
- (b) The fault path is from the live conductor through the fault to the equipotentially bonded system to the neutral. The current is likely to exceed 30 mA. The magnitude of the current is not influenced by the presence or absence of an earth electrode.
- (c) Fault between live parts and the mass of earth:
 - (i) *Example A: A generator on the back of a truck* The fault path is from the live parts to the mass of earth-through the insulation resistance of the tyres and truck tray parts to the generator frame, which is connected to the neutral.

The tyres are high resistance so the current is low and the situation is similar to an isolated system. The current is likely to be below 30 mA
 - (ii) *Example B: A generator resting on the mass of earth* The fault path is from the live parts to the mass of earth through the casual resistance of the generator frame which is connected to the neutral.

The casual resistance of the generator frame to the mass of earth may be low so the current may exceed 30 mA.
 - (iii) *Example C: A generator with an earth electrode* The fault path is from the live parts to the mass of earth through the resistance of the earth electrode to the generator frame which is connected to the neutral.

The earth resistance is lower than for Example B and the current is likely to exceed 30 mA.

2.4.6.4 *Electrical equipment supplied by inverters*

Inverters used on construction and demolition sites shall comply with the requirements of AS/NZS 4763(Int) and be one of the following types:

- (a) An RCD protected inverter (RCDP Inverter) with a maximum rated residual current of 30 mA.
- (b) An isolated inverter.

Isolated inverters shall only be used on construction and demolition sites to supply a separated circuit for electrical equipment, installed in accordance with the electrical separation requirements of AS/NZS 3000. Each winding shall supply not more than one item of Class I (earthed conductive parts) electrical equipment.

NOTES:

- 1 AS/NZS 4763(Int) requires identification of the classification, by the means given in Paragraph H1.
- 2 One or more items of Class II (double insulated) electrical equipment may be connected to an isolated winding inverter.
- 3 Wiring of dedicated battery storage systems for inverters should comply with AS/NZS 3000, Clause 7.8. Battery storage systems should comply with AS 4086.2.

2.4.6.5 *Permanent wiring located where construction or demolition work may be carried out*

Permanent wiring located where construction or demolition work may be carried out shall be considered to be energised until proven otherwise by inspection and testing.

All energized permanent wiring located where construction or demolition work may be carried out shall be suitably identified and assessed for the risk of mechanical and environmental damage from construction activities. If a risk of damage exists, such wiring shall be protected in accordance with Clause 2.5.3.

NOTE: Particular care should be taken with permanent wiring located in ceiling spaces. All permanent wiring should be considered to be live until proven otherwise.

2.4.7 Switching of single-phase socket-outlets

Every single-phase socket-outlet in the following situations shall be individually controlled by a double-pole switch—

- Portable generators of the isolated winding type fitted with integral socket-outlets;
- Portable inverters of the isolated type fitted with socket-outlets;
- Portable socket-outlet assemblies;
- In Australia only, on or in transportable structures that are connected to supply by a flexible cord and plug; and
- Socket-outlets on equipment that is supplied by means of a plug and socket.

NOTE: Socket-outlets may be either the type with a manual switch or an integral switch that switches on when the plug top is inserted and switches off when it is removed.

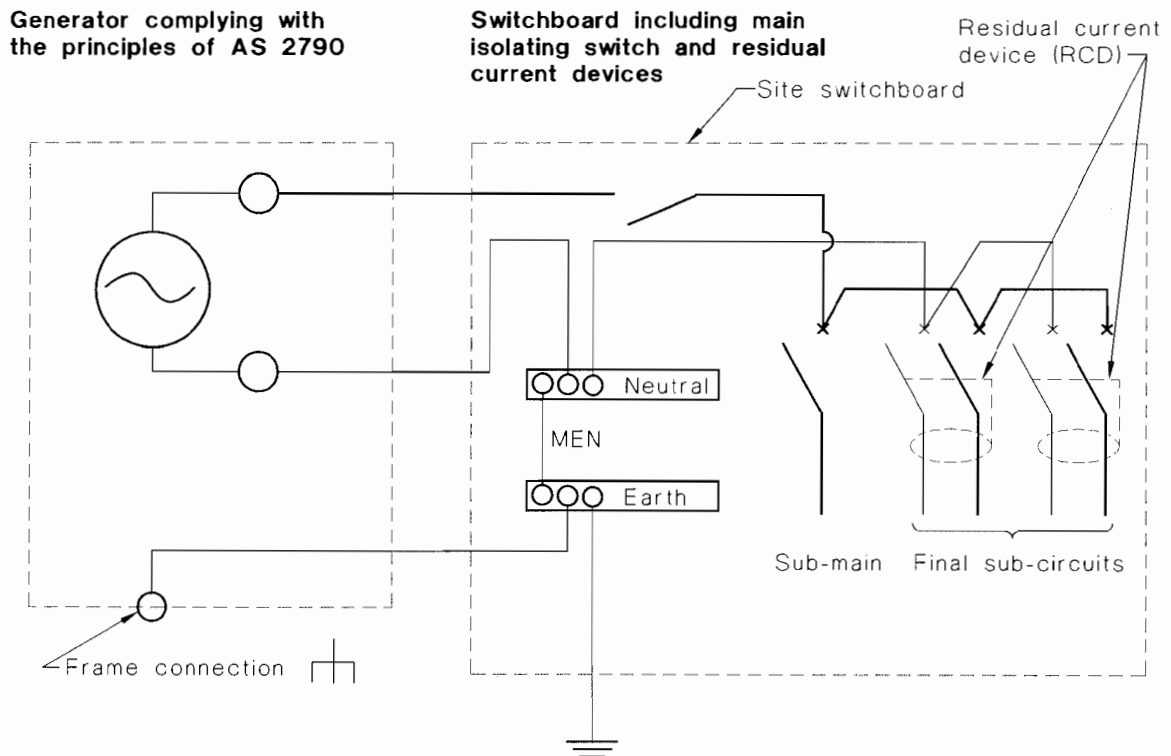

FIGURE 2.1 CONNECTION FROM STAND-ALONE GENERATOR TO SITE SWITCHBOARD WITH AN MEN LINK AND ELECTRODE

Generator complying with
the principles of AS 2790

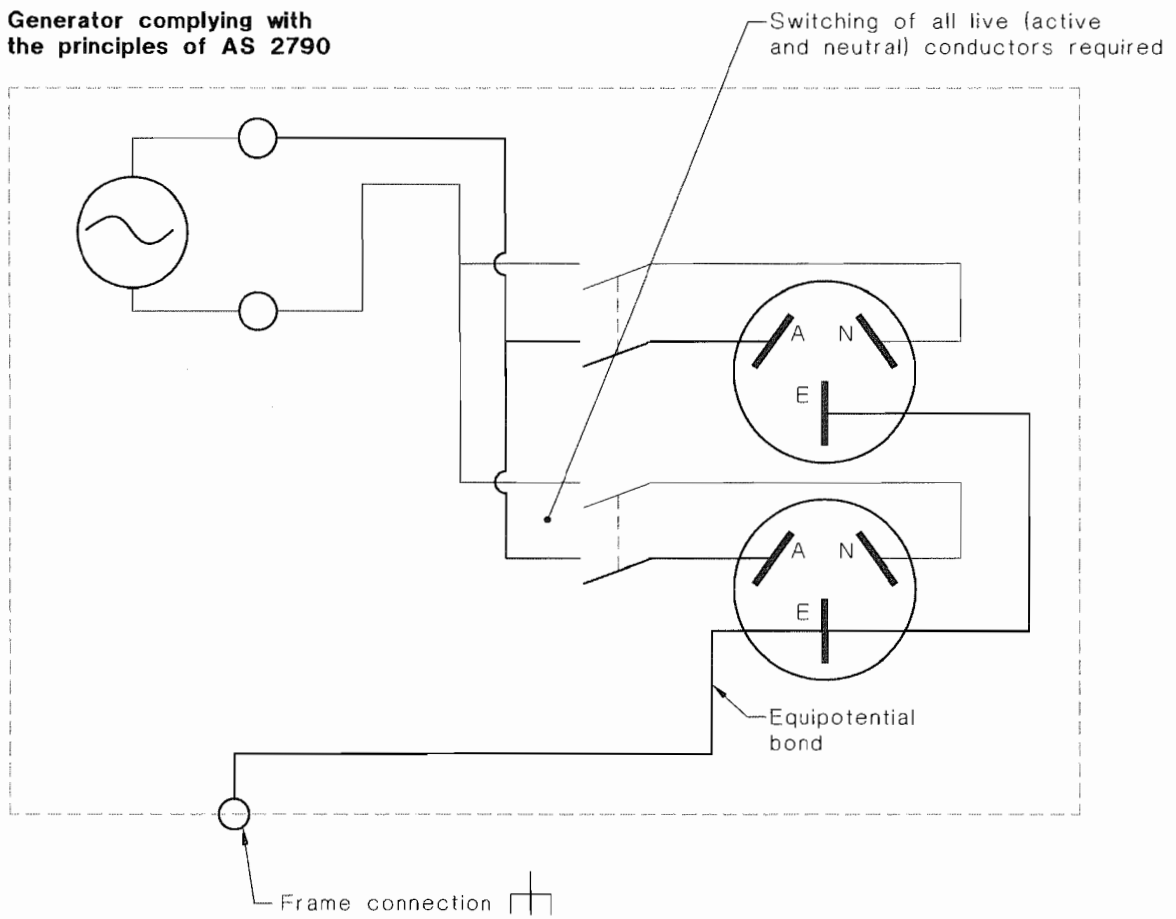

FIGURE 2.2 ISOLATED WINDING GENERATOR WITH INTEGRAL SOCKET-OUTLETS

Generator complying with the principles of AS 2790

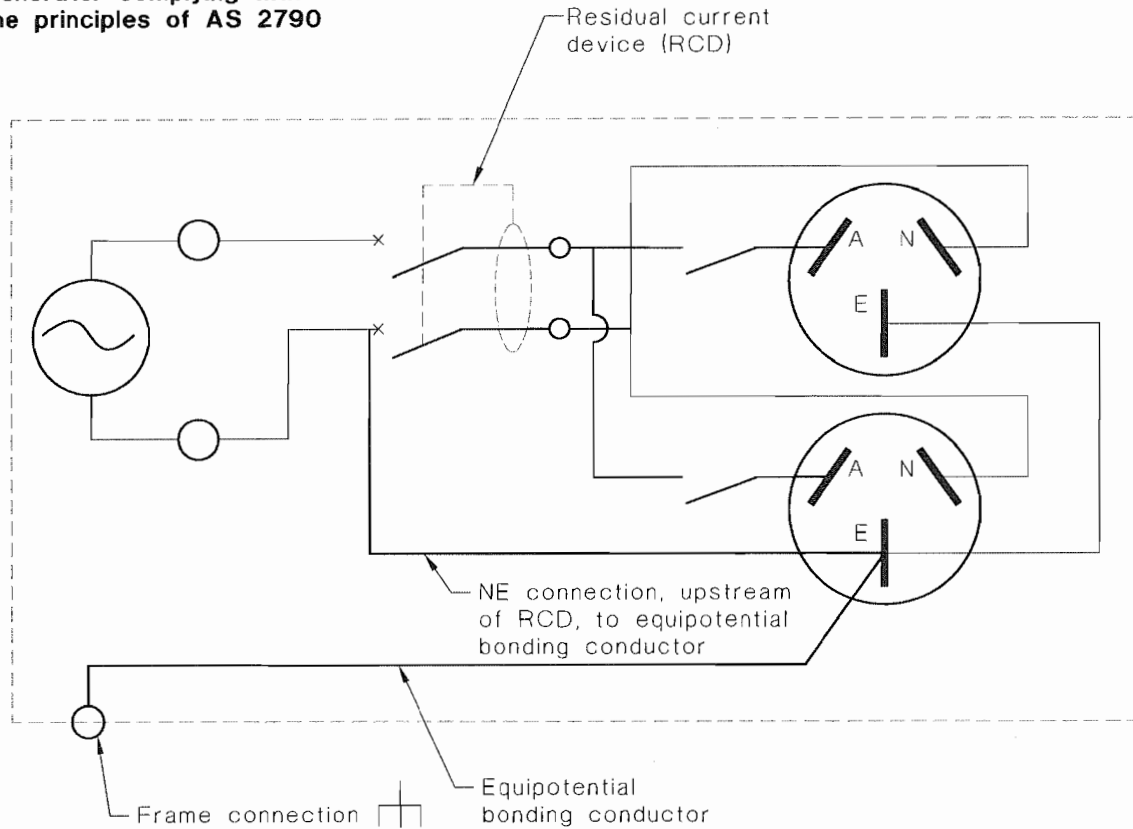

FIGURE 2.3 GENERATOR WITH INTEGRAL RCD PROTECTED SOCKET-OUTLET

2.5 CONSTRUCTION WIRING

2.5.1 Cables and fittings

Cables and fittings used in construction wiring shall comply with the requirements of AS/NZS 3000.

NOTE: The requirements of AS/NZS 2802 apply to trailing cables used for surface wiring.

2.5.2 Installation of cables

Cables shall be installed in accordance with AS/NZS 3000 except as varied in Clauses 2.5.3 to 2.5.8 below. Construction wiring shall not be tied, bundled or grouped with permanent wiring.

2.5.3 Protection against mechanical damage

A risk assessment should be undertaken, prior to the installation of cables or whenever a change occurs, as to the likelihood of the cables being exposed to mechanical damage.

Where the risk assessment identifies a risk of damage to cables, and the cables cannot be relocated to an alternative position, they must be protected by a suitable enclosure or barrier not less effective than—

- (a) medium duty rigid or corrugated conduit of insulating material; or
- (b) heavy duty rigid or corrugated conduit of insulating material; or
- (c) flexible electrical hose; or
- (d) armoured cable; or
- (e) other means that provide equivalent protection against mechanical damage. AS/NZS 3000 provides guidance in Appendix H.

Where a risk assessment is not undertaken, protection against mechanical damage by the use of a suitable enclosure or barrier not less effective than Items (a) to (e) above shall be provided.

NOTE: The following are typical examples of situations where cables may require mechanical protection:

- (a) Cables run within 2.5 m of the floor or ground level.
- (b) Cables run on exterior surfaces and in close proximity to scaffolding.
- (c) Cables supplying switchboards and final sub-circuits to equipment located on formwork decks.
- (d) Cables run on the site's perimeter fencing that are securely fixed in position, e.g. by securing the posts in the ground or by fixing to another secure structure. Cabling is NOT to be attached to free-standing fencing.
- (e) Cables slung under a concrete ceiling slab more than 150 mm away from the juncture of the ceiling slab and a wall or beam that would otherwise provide protection.
- (f) Cables coming in close proximity to unearthed metal structures being installed as part of the construction process (for example sheet metal ducts and hydraulic piping).
- (g) Cables run across the top of transportable structures, storage containers, shipping containers or the like.
- (h) Cables run across or over metallic roofs or edges.
- (i) Cables run in adverse environments.

2.5.4 Marking

Construction wiring shall be readily distinguishable from permanent wiring by using cable sheaths of a different colour or by attaching iridescent yellow tape spaced at intervals not exceeding 5 m and marked with the words 'construction wiring'. If live permanent wiring is located where construction activity is occurring it, or its location, shall be marked as live with the words 'live wiring' at intervals not exceeding 5 m. Live permanent wiring shall be readily distinguishable from construction wiring.

NOTE: Unidentified wiring is deemed to be live.

2.5.5 Use of unarmoured cables

Unarmoured cables shall not be installed on metallic roofs or similar structures unless suitably protected against mechanical damage.

2.5.6 Location and marking of overhead wiring (including aerial and catenary wiring)

Overhead wiring should be positioned to avoid crossing roadways or access ways where cranes, high loads or heavy machinery may travel.

Where it is not possible to avoid access ways, an effective means shall be provided to minimize the risk of vehicular contact with the overhead wiring system.

This condition may be satisfied by the placement of flagged catenary wires or cables of suitable material across the access way—

- (a) 6 m on either side of the overhead wiring; and
- (b) 0.6 m below the lowest point of the overhead electrical cables or lower.

2.5.7 Type of aerial conductor

All aerial conductors installed on construction and demolition sites shall be insulated.

NOTES:

- 1 Where underground or bare aerial conductors owned by the electricity distributor are located on or near the site it is recommended the electricity distributor be consulted about de-energizing, providing adequate safety clearances, or insulating the conductors, as applicable.
- 2 Local regulations may prohibit the use of aerial conductors in bushfire-prone areas.

2.5.8 Cables supported by a catenary

Cables supported by means of a catenary shall be stranded or flexible cables affording double insulation or the equivalent of double insulation.

Cables supported by a catenary shall maintain clearances in accordance with AS/NZS 3000.

NOTE: Local regulations may prohibit cables supported on catenaries in bushfire-prone areas.

2.6 FLEXIBLE CORDS, CORD EXTENSION SETS, FLEXIBLE CABLES AND ACCESSORIES

2.6.1 General

Clause 2.6 applies to the following:

- (a) Flexible cords

Exception: This clause does not apply to flexible cords that are:

- (i) permanently attached to electrical equipment; or
- (ii) 5 m or less in length.

- (b) Accessories used to connect electrical equipment to switchboards.

- (c) Flexible cables.

- (d) Cord extension sets.

Cord extension sets shall comply with AS/NZS 3199 except as varied by Clauses 2.6.2 to 2.6.9. All cords shall be wired identically.

2.6.2 Minimum conductor size and core configuration

The minimum cross-sectional area of each conductor in a flexible cord shall be 1.0 mm². Flexible cords shall contain an earthing conductor in addition to the live conductors.

2.6.3 Type of flexible cord and cable

Flexible cords used in cord extension sets shall be heavy duty sheathed and shall comply with AS/NZS 3191. Flexible cable shall comply with AS/NZS 5000.

2.6.4 Colour

The sheath of a flexible cord shall not contain the colour green.

NOTE: This is to avoid potential confusion with individual earthing conductors.

2.6.5 Current-carrying capacity

Every conductor shall have a current-carrying capacity not less than the current it is expected to carry.

This current-carrying capacity shall be determined in accordance with—

- (a) in Australia, AS/NZS 3008.1.1; or
- (b) in New Zealand, AS/NZS 3008.1.2.

NOTE: AS/NZS 3000 gives details on simplified protective device selection.

2.6.6 Accessories for connection

Cord extension sets shall be fitted with the following accessories for connection:

- (a) A plug in accordance with—
 - (i) AS/NZS 3112; or
 - (ii) AS/NZS 3123; or
 - (iii) IEC 60309.



- (b) A cord extension socket in accordance with—
- (i) AS/NZS 3120; or
 - (ii) AS/NZS 3123; or
 - (iii) IEC 60309.

Double adaptors and 3-pin plug adaptors (piggyback) or similar fittings shall not be used on construction and demolition sites.

2.6.7 Maximum length

The maximum length of a flexible cord, for a given conductor cross-sectional area, shall comply with Table 1.

TABLE 1
MAXIMUM LENGTHS OF FLEXIBLE CORDS AND FLEXIBLE CABLES

1	2	3	4	5	6
Rated current	Conductor area	Maximum length of flexible cords and cables, in metres			
		General use (length based on 5% voltage drop at rated current)		Specific use for circuits where the safety of personnel utilising the equipment is dependent on the reliable starting of motors. (length based on 3% voltage drop at rated current)	
		Single phase 3 core cable (L, N, E)	Three phase 4 core cable (L1, L2, L3, E)	Single phase 3 core cable (L, N, E)	Three phase 4 core cable (L1, L2, L3, E)
		(A)	(mm²)	(m)	(m)
10	1.0	25	50	15	30
	1.5	35	70	20	40
	2.5	60	120	35	70
	4.0	100	200	60	120
15/16	1.5	25	50	15	30
	2.5	40	80	25	50
	4.0	65	130	40	80
	6.0	100	200	60	120
	10.0	170	340	100	200
20	2.5	30	60	20	40
	4.0	50	100	30	60
	6.0	75	150	45	90
	10.0	130	260	75	150

NOTES:

- The lengths for 4 core cables above assume a balanced three phase load.
- Examples of equipment covered in Columns 5 and 6 are trailing cables for suspended scaffolds, swing stages and false cars.
- Examples of equipment covered in Columns 3 and 4 are tools including saws, grinders and drills.
- The percentage voltage drops given are in addition to the 5% maximum voltage drop allowed in the installation to the point of connection.

2.6.8 Limitations on the use of cord extension sets

Cord extension sets shall—

- (a) when used in multistorey buildings, be confined to the storey of the switchboard from which they originate.

Exception: This requirement need not apply to work in lift shafts, stairwells, service shafts, formwork, external staging or sub-mains of construction wiring or a single domestic residence as detailed in Appendix B.

NOTE: Within each storey, switchboards (or auxiliary socket-outlet panel boards) should be positioned to ensure that the maximum permitted length of flexible cords is not exceeded.

- (b) not be joined such that the total length of any such combination exceeds the relevant maximum value specified in Clause 2.6.7.

NOTE: It is recommended that a single cord extension set be used.

Flexible extension cords should not be used while in a coiled or reeled configuration.

2.6.9 Protection of flexible cords or cables

Flexible cords and cables shall not be subject to mechanical damage, damage by liquids or damage by high temperatures.

Where flexible cords or cables supplying electrical equipment are more than 4m in length or are not in view of the person using the electrical equipment, they shall be—

- (a) provided with suitable protection against, or located where they are not subjected to, mechanical damage, damage by liquids or high temperature; or
- (b) supported off the floor or ground on stands or hangers covered with material that is non-conducting and will prevent mechanical damage to the cable.

2.6.10 Portable socket-outlet assemblies (PSOAs)

Portable socket-outlet assemblies shall comply with the requirements of a Class H portable residual current device to AS/NZS 3190 and include, where not specifically stated as requirements of the above-mentioned Class H portable residual current devices or socket-outlet assemblies, the following:

- (a) The enclosure shall be constructed of a suitable impact resistant and durable material and shall be of Class II (double insulated) construction.
- (b) Socket-outlets mounted on the assembly shall—
 - (i) comply with AS/NZS 3112, AS/NZS 3123 or IEC 60309;
 - (ii) be protected against damage by suitable means such as covers or extended sides;
 - (iii) if single phase, be individually controlled by a double-pole switch; and
 - (iv) shall have a degree of protection appropriate for the environment, subject to a minimum degree of protection of IP33.
- (c) The flexible cord supplying the assembly shall be—
 - (i) of the heavy duty sheathed type complying with AS/NZS 3191;
 - (ii) fitted with a plug complying with AS/NZS 3112, AS/NZS 3123 or IEC 60309; and
 - (iii) a maximum length of 2 m.
- (d) The assembly shall incorporate overload protection with a rating no greater than the rating of the flexible cord and plug supplying the assembly. Where three or more socket-outlets are fitted to the assembly, overload protection shall be provided by a miniature overcurrent circuit-breaker complying with AS 3111, AS/NZS 60898.1 or AS/NZS 60898.2. The socket-outlet rating shall not exceed the rating of the overload protection device, i.e. a 10 A assembly shall not be fitted with 15 A socket-outlets.
- (e) All socket-outlets mounted on these assemblies shall be protected by a RCD with a maximum rated residual current of 30 mA that operates in all live (active and neutral) conductors.
- (f) The assembly shall be marked, to indicate compliance with this Standard.*

NOTES:

- 1 These assemblies may be single-phase or three-phase.
- 2 For the purpose of calculating the maximum allowable length of flexible cord (from Table 1), the length of the supply flexible cord to the portable socket-outlet assembly should be taken into account.
- 3 As a PSOA is a type of portable RCD (PRCD), it is a declared article and must comply with the relevant requirements of AS/NZS 3190 and have regulatory approval.

* Applicable 2 years after publication of this Standard.

2.6.11 Auxiliary socket-outlet panels

Auxiliary socket-outlet panels shall be constructed to comply with the following general requirements:

- (a) The panel shall be—
 - (i) of robust construction and materials to withstand mechanical damage from the environment or other external influences that may be expected at the location;
 - (ii) located at a height of between 1.2 to 2 m above the floor and mounted securely to a permanent structure or a temporary structure that has been specifically designed for the purpose;
 - (iii) provided with an isolating switch controlling the incoming supply, with the switch clearly marked to indicate its function unless the function of the switch is obvious;
 - (iv) supplied by a dedicated final sub-circuit protected at the switchboard where the final sub-circuit originates by an RCD, with a maximum rated residual current of 30 mA, that operates in all live (active and neutral conductors) in accordance with Clause 2.4.6.1 and a circuit-breaker in accordance with Clause 2.4.5.2;
 - (v) provided with means to prevent mechanical damage to outgoing cables and relieve strain on plug and socket-outlet connections of flexible cords; and
NOTE: A typical means of achieving this is by providing a support (e.g. tie bar, hanger, cross arm or stand) covered with a non-conductive material to which the cables can be anchored.
 - (vi) labelled in accordance with Clause 2.1.3 to indicate the source of supply.
- (b) The panel shall have a degree of protection appropriate for the environment in which it is installed subject to a minimum degree of protection IP23.
- (c) Socket-outlets mounted on the panel shall—
 - (i) comply with AS/NZS 3112, AS/NZS 3123 or IEC 60309; and
 - (ii) be protected against damage by extended sides or covers; and
 - (iii) be rated at not less than 10 A and be individually controlled by a double pole switch.
- (d) The cable from the switchboard to the panel is construction wiring and shall be—
 - (i) a minimum cross-sectional area of 4 mm² for active and neutral conductors and corresponding 2.5 mm² earth conductors;
 - (ii) when used in multistorey buildings, confined to the storey of the switchboard from which they originate, except in lift shafts, service shafts, mezzanine levels, stairwells, formwork or external staging;
 - (iii) compliant with the AS/NZS 5000 series;
 - (iv) identified in accordance with Clause 2.5.4; and
 - (v) protected, where required, from mechanical damage in accordance with Clause 2.5.3.

2.6.12 Electrical portable outlet devices (EPODS)

Electrical portable outlet devices to AS/NZS 3105 (e.g. domestic type power boards) do not comply with the requirements of Clauses 2.6.10 or 2.6.11 and shall not be used on construction and demolition sites.

2.7 LIGHTING AND LUMINAIRES

2.7.1 General lighting

Recommended minimum lighting levels are 40 lx for walkways and 160 lx for general areas.

2.7.2 Mechanical protection

Lamps in luminaires shall be protected against mechanical damage.

2.7.3 Emergency evacuation lighting

Emergency evacuation lighting, when required, shall be sufficient to allow safe egress from the site.

As a minimum requirement, sufficient battery-powered lighting shall be installed in stairways and passageways and adjacent to switchboards to allow safe access to and egress from the area if there is insufficient natural lighting. Emergency lighting at a minimum level of 20 lx shall be provided for a minimum of one hour following loss of normal lighting in the area.

Guidance on appropriate spacings for luminaires can be found in AS 2293.1.

Internally illuminated emergency evacuation signage may be integrated in an existing emergency lighting system providing that system of lighting incorporates battery backup light fittings capable of illuminating the exit signage and providing clear direction on the safe means of egress from the workplace in the event of power failure.

2.7.4 Hand-held luminaires

Hand-held luminaires shall comply with AS/NZS 60598.2.8.

2.7.5 Edison screw type lampholders

Every low voltage edison screw lampholder shall be connected to the supply so that, where a neutral conductor is required, it shall be connected to the outer contact.

2.7.6 Festoon lighting

- (a) Festoon lampholders shall be permanently moulded to their supply cable and shall be provided with a non-conductive mechanical guard for the lamp.
- (b) The maximum permitted operating voltages for festoon lighting are:
 - (i) In Australia, extra-low voltage (≤ 50 V a.c.).
 - (ii) In New Zealand, low voltage (e.g. 230 V a.c.) provided the circuit is protected by 30 mA RCDs, as detailed in Clause 2.4.6.
- (c) Festoon lighting shall be supported at least 2.5 m above any floor, ground, platform or working area or be installed immediately below a ceiling.

Exception: This requirement need not apply in stairwells, lift shafts, and service shafts where adequate support shall be provided.

2.7.7 Portable luminaires

Portable luminaires shall be provided with the following:

- (a) A minimum degree of protection IP2X in accordance with AS 60529.
- (b) A mechanical guard for the lamp.
- (c) Adequate stability.

A

NZ

2.8 LIFT SHAFTS

2.8.1 General

Construction wiring dedicated to the installation of lift shaft equipment shall consist of a separate final sub-circuit protected in accordance with Clause 2.4.6.1.

Circuit breakers shall be locked and tagged to prevent inadvertent isolation of supply to the lift shaft by others on the site.

Lift shaft lighting shall be supplied from either construction wiring or permanent wiring and should conform with the following minimum requirements:

- (a) Luminaires should be—
 - (i) at a minimum lighting level equivalent to that provided by a 36 watt fluorescent and suitably guarded against mechanical damage;
 - (ii) connected to supply via a plug and socket arrangement; and
 - (iii) installed at intervals not exceeding 6 m with the uppermost fixture installed within 1 m of the top of the lift shaft.
- (b) The relevant requirements of AS 1735.2 apply where lighting is installed and intended to be part of the permanent lift installation.

2.8.2 Multiple lift shafts

Where a lift shaft will contain more than one lift, the vertical space provided for one lift should be provided with effective illumination from the vertical space provided for the immediately adjacent lift.

2.8.3 Emergency lighting

Emergency lighting at a minimum level of 20 lux shall be provided for a minimum duration of one hour following loss of normal lighting to allow safe egress from the lift shaft. (Refer to the relevant requirements of AS/NZS 1680.0).

Emergency lighting shall be positioned so that persons can exit at each egress point from the lift shaft.

2.8.4 False-car (Guided work platform)

Where false-cars are installed for the purpose of the installation of lift shaft equipment, construction wiring for electrical supply to the false-car should conform to the following requirements:

- (a) Be supplied from a minimum 230 V, 20 A socket-outlet on a separate final sub-circuit protected by a 30 mA residual current device that operates in all live (active and neutral) conductors. The supply should be provided for the sole purpose of providing adequate power to the climbing hoist, including task lighting and power for the use of electrical tools when working from the false-car working platform.
- (b) Electrical wiring providing supply to the false-car working platform shall be heavy duty double insulated flexible cord or cable with a minimum conductor size of 4 mm².
- (c) The flexible cord or cable should be—
 - (i) secured at the top of the lift shaft and at the point of attachment to the false-car by suitable means to prevent mechanical damage;
 - (ii) suspended in the lift shaft in a manner that will ensure adequate running clearance between the false-car and the lift shaft to prevent fouling or mechanical damage to the cord or cable; and
 - (iii) of sufficient length to allow for free travel of the false-car throughout the length of the lift shaft.

2.9 TRANSPORTABLE STRUCTURES

Electrical installations of transportable structures and their site supplies shall comply with AS/NZS 3001 and with the following:

- (a) Transportable structures shall be supplied by one of the following methods:
- (i) Sub-mains originating at a circuit-breaker on a switchboard and installed as construction wiring.
 - (ii) Final sub-circuits originating at a circuit-breaker on a switchboard and installed as construction wiring.
 - (iii) Flexible cord and plug connected to a final sub-circuit via a socket-outlet in accordance with the requirements of AS/NZS 3001 including—
 - (A) each socket-outlet shall have a degree of protection not less than IPX4, both when the plug is inserted and when it is not;
 - (B) each socket-outlet shall be individually protected by a circuit-breaker;
 - (C) the circuit-breaker shall not have a rating greater than that of the socket-outlet, except where a 16 A circuit-breaker is protecting a 15 A socket-outlet; and
 - (D) each socket-outlet shall be protected by an RCD with an operating current not exceeding 30 mA that operates in all live conductors (active and neutral).

NOTE: It is recommended that a separate RCD is provided for each socket-outlet to minimize the impact of the operation of a single RCD.

Supply shall not be taken from a socket-outlet associated with one transportable structure to supply another transportable structure except where item (e) applies.

- (b) Where supplied by flexible cord the minimum cross-sectional area of the flexible cord shall be 2.5 mm² and the maximum length of flexible cord shall be 15 m.
- (c) Socket-outlets installed inside transportable structures shall—
- (i) be protected by RCDs, with a maximum rated residual current of 30 mA, that operate in all live (active and neutral) conductors;
 - (ii) be used only to supply electrical equipment and lighting within that transportable structure; and
 - (iii) in Australia, where the structure is supplied by flexible cord and plug, be controlled by double-pole switches. A
- (d) Socket-outlets installed on the outside of transportable structures shall—
- (i) be protected by 30 mA RCD that operates in all live (active and neutral) conductors; and
- Exceptions: This condition need not apply to—*
- (A) *supply to other transportable structures as described in Clause 2.9(d)(iv) below; and*
 - (B) *sub-main (interconnecting cable) supply systems complying with Appendix K.*
- (ii) be used only to supply electrical equipment and lighting located immediately adjacent to the structure; and
 - (iii) be controlled by switches that operate in all live (active and neutral) conductors, where the structure is supplied by flexible cord and plug; and

- (iv) only supply power to other transportable structures when the socket-outlet is part of an interconnecting system in accordance with (e) below.
- (e) All components of an interconnecting supply system for transportable structures shall be of equal or greater current carrying capacity than the protective devices that protect the interconnecting system at the point of connection to the supply. Overcurrent devices incorporated in the interconnecting system may be used to provide overcurrent protection to individual cables.

NOTE: In New Zealand, some caravans may include a link between neutral and earth. In order to avoid inappropriate operation of any upstream RCD, caravans that are fitted with such a link should be modified to comply with the requirements in AS/NZS 3001.



SECTION 3 VERIFICATION (INSPECTION AND TESTING)

3.1 APPLICATION

This Section describes the verification (inspection and testing) procedures and frequency to be followed on all components of the electrical installations of construction and demolition sites. It applies to—

- (a) construction wiring;
- (b) switchboards;
- (c) RCDs;
- (d) transportable structures;
- (e) the connection between generator windings and the equipotential bonding system on generators fitted with an RCD;
- (f) the connection between the frame and the equipotential bonding system of an isolated winding generator;
- (g) inverters; and
- (h) any other electrical equipment used on construction and demolition sites.

3.2 FREQUENCY OF VERIFICATION (INSPECTION AND TESTING)

The frequency of verification is determined by examination of the actual environment where the equipment is being used rather than the type of equipment in use. The frequency is based on the level of hazard/risk and the degree of abuse to which the equipment is exposed. This consideration should be based on the specific conditions immediately effecting the particular item of equipment and not on general site conditions.

NOTE: Regulatory authorities, other Standards, workplace safety requirements or manufacturers' instructions may specify shorter intervals appropriate to particular industries or specific types of equipment.

Construction wiring and electrical equipment shall be inspected and tested as follows:

- (a) For new equipment, prior to the initial introduction into service.
- (b) Before return to service after a repair or servicing, which could have affected the electrical safety.
- (c) For hire equipment, inspection prior to each hire and testing at not greater than monthly intervals. If hire equipment remains on site then Table 3 applies.
- (d) At intervals not exceeding those specified in Table 3.

3.3 PERSONNEL

The verification (inspection and testing) required by Clauses 3.4 and 3.7(b) shall be carried out by a qualified person authorized to carry out the electrical installation work required.

The verification (inspection and testing) required by Clauses 3.5, 3.6 and 3.7(a) inclusive shall be carried out by a competent person.

3.4 CONSTRUCTION WIRING AND TRANSPORTABLE STRUCTURES

3.4.1 Initial verification

All construction wiring, including switchboards, fixed RCDs and transportable structures, shall be verified (inspected and tested) in accordance with AS/NZS 3000 following initial installation.

3.4.2 Periodic verification

Construction wiring (including switchboards and transportable structures) shall be visually inspected to verify the integrity of the installation at intervals not exceeding those specified in Table 3. RCDs shall be tested in accordance with Clause 3.5. Faults shall be rectified in accordance with Clause 3.8.1.

In New Zealand only, complete a construction and demolition verification certificate after completion of the verification detailed in Clause 3.4.2 .

NZ

NOTE: A suitable form is contained in Appendix I.

3.5 RCDS

RCDs shall—

- (a) be successfully operated by means of their in-built test facility (push-button); and
- (b) be subject to and comply with a test for operating time of RCDs in accordance with AS/NZS 3760.

NOTES:

- 1 An RCD tester may be used for this test.
- 2 Fixed RCDs include switchboard types and socket-outlet types.
- 3 Portable RCDs include RCDs on portable equipment.

3.6 OTHER ELECTRICAL EQUIPMENT ON SITE

3.6.1 General

All other electrical equipment on site, including power tools, flexible cords, cord extension sets and portable socket-outlet assemblies, shall be tested in accordance with Clauses 3.6.2 and 3.6.3, as appropriate, and inspected in accordance with the methods of AS/NZS 3760, before being put into service and thereafter at intervals not exceeding those listed in Table 3 of this Standard.

3.6.2 Protective earthing continuity

All Class I (earthed conductive parts) electrical equipment shall have the continuity of the protective earthing conductor from the plug earth pin or supply point to exposed conductive parts tested in accordance with the requirements of AS/NZS 3760.

The measured earthing conductor resistance values shall be less than the maximum values given in AS/NZS 3760.

NOTE: In accordance with AS/NZS 3760, equipment should not be dismantled to perform these tests.

3.6.3 Insulation resistance or leakage current

The insulation resistance or leakage current of Class I (earthed conductive parts) and Class II (double insulated) electrical equipment shall be tested in accordance with the method given in AS/NZS 3760, except that, for fixed equipment, the insulation resistance shall be measured from the earth terminal of the equipment rather than the earth pin of a plug.

The insulation resistance values measured shall be not less than the minimum values given in AS/NZS 3760.

3.6.4 Arc welding equipment

Where arc welders are incorporated into generating sets, tests shall be conducted to ensure that the insulation resistances are not less than those given in Table 2.

TABLE 2
MINIMUM INSULATION RESISTANCE

Parts to be tested			Minimum insulation resistance (M Ω)
Input circuit (including control circuits connected to it)	to	Welding circuit (including control circuits connected to it)	5
All circuits	to	Exposed conductive parts	2.5
Welding circuit (including control circuits connected to it)	to	Any auxiliary circuit that operates at a voltage exceeding extra-low-voltage	10
Welding circuit (including control circuits connected to it)	to	Any auxiliary circuit that operates at a voltage not exceeding extra-low-voltage	1
Separate welding circuit	to	Separate welding circuit*	1

* In the case of multiple welding circuit outlets.

3.7 CONNECTION BETWEEN GENERATOR WINDINGS, FRAME AND EQUIPOTENTIAL BONDING SYSTEM

Connections shall be tested and verified as follows:

- Where an RCD is used with, or connected to, a generator, the integrity of the connection between the generator windings and the equipotential bonding system on the generator (refer to Figure 2.3) shall be verified in accordance with Appendix G.
- Where, in accordance with Clause 2.4.6.3(b), an isolated winding generator is used, the continuity of the connection from the frame to the equipotential bonding system (refer to Figure 2.2) shall be tested. The resistance of this connection shall be less than 1 Ω . In addition, the insulation resistance between the generator winding and the frame shall be greater than 1 M Ω .

3.8 ACTIONS RESULTING FROM INSPECTION AND TEST

3.8.1 Construction wiring

Where a visual inspection identifies damage or non-compliance with this Standard, that part of the installation shall be isolated, repaired or replaced and tested as required.

3.8.2 Non-compliant equipment

Where inspection or testing identifies equipment that fails to comply with the criteria given in this Standard, the equipment shall be—

- withdrawn from service immediately, have a label attached to it warning against further use; and
- sent for repair, disposal or destruction by an authorized repair agent or service personnel.

3.8.3 Compliant equipment

New equipment, after inspection and tests shall be fitted with a durable, non-reusable, non-metallic tag. Construction wiring, switchboards, fixed RCDs, fixed and transportable electrical equipment need not be tagged.

Following periodic verification (inspection and testing), compliant equipment shall be re-tagged. The items covered in Clause 3.4.2 need not be tagged.

The tag, which may be colour coded to identify the period in which the test was performed, shall include the—

- (a) name of the person or company who performed the tests; and
- (b) test or re-test date.

NOTE: Appendix F gives a recommended colour coding schedule for tags on compliant equipment

TABLE 3
PERIODIC VERIFICATION INTERVALS

1	2	3	4	5	6	7
Environment	Transportable structures, Class I (earthed conductive parts) and Class II (doubled insulated) electrical equipment		Residual current devices (RCDs)			
	Transportable structures¹, fixed and transportable equipment² and construction wiring³ including switchboards	Portable equipment⁴	Pushbutton test (by user)		Operating time (RCD tester)	
			Portable⁵	Non-portable fixed⁶	Portable^{5,7}	Non-portable fixed⁶
Construction and demolition sites in accordance with Clause 1.1	6 months	3 months	After connection to a socket or before connection of equipment, and at least once every day in use.	1 month	3 months	12 months

NOTES:

- 1 In New Zealand, verification (inspection and testing) intervals for transportable structures do not apply.
- 2 Transportable structures and fixed and transportable electrical equipment (Clause 3.6).
- 3 Construction wiring including switchboards (Clause 3.4).
- 4 Portable equipment—appliances, flexible cords, cord extension sets, PSOAs, generators, inverters, (Clause 3.6) excluding hire equipment (see Clause 3.2(c)).
- 5 Portable RCD includes RCDs on portable equipment, or RCDs associated with portable generators (Clause 3.5) or RCD protected inverters.
- 6 See Clause 3.5 for details of the required test.
- 7 Includes connection between generator winding and equipotential bonding system (Clause 3.7).

NZ

3.9 PORTABLE GENERATOR SETS AND INVERTERS

Electrical verification of portable generator sets shall be carried out in accordance with Appendix G.

Electrical verification of portable inverters shall be carried out in accordance with Appendix H.

3.10 DOCUMENTATION

Records of inspection and tests shall be kept. All the following should be recorded:

- (a) A register of all equipment.
- (b) A record of formal inspection and tests.
- (c) A repair register.
- (d) A record of all faulty equipment.
- (e) For construction wiring:
 - (i) Visual inspection—date, checklist (as per AS/NZS 3000 checklist).
 - (ii) Continuity of earthing system—values obtained for main earth, bonding earth and protective earth.
 - (iii) Insulation resistance value.
 - (iv) Polarity—checklist.
 - (v) Correct circuit connections—checklist.
 - (vi) RCD—values for trip time.

NOTE: Electronic records are acceptable.

Where an item is not tagged, in accordance with Clause 3.8.3, records shall be available on site for audit or made available for audit on the next working day.

In addition, electrical regulators may require further documentation for compliance of the installation and electrical work.

NOTE: The existing State regulatory requirements for certification of electrical work may be used for the documentation required in 3.10(e) subject to the recording of values. Copies of the certification are retained by the electrician and the builder or owner/occupier.

APPENDIX A
LIST OF REFERENCED DOCUMENTS
(Normative)

AS	
1735	Lifts, escalators and moving walks
1735.2	Part 2: Passenger and goods lifts—Electric
2293	Emergency escape lighting and exit signs for buildings
2293.1	Part 1: System design, installation and operation
2790	Electricity generating sets—Transportable (Up to 25 kW)
3111	Approval and test specification—Miniature overcurrent circuit-breakers
4086	Secondary batteries for use with stand-alone power systems
4086.2	Part 2: Installation and maintenance
60269	Low-voltage fuses (all parts)
60529	Degrees of protection provided by enclosures (IP code)
60947	Low-voltage switchgear and controlgear
60947.2	Part 2: Circuit-breakers
AS/NZS	
1680	Interior lighting
1680.0	Part 0: Safe movement
2802	Electric cables—Reeling and trailing for mining and general use (other than underground coal mining)
3000	Electrical installations (known as the Australian/New Zealand Wiring Rules)
3001	Electrical installations—Transportable structures and vehicles including their site supplies
3008	Electrical installation—Selection of cables
3008.1.1	Part 1.1: Cables for alternating voltages up to and including 0.6/1 kV—Typical Australian installation conditions
3008.1.2	Part 1.2: Cables for alternating voltages up to and including 0.6/1 kV—Typical New Zealand installation conditions
3010	Electrical installations—Generating sets
3105	Approval and test specification—Electrical portable outlet devices
3112	Approval and test specification—Plugs and socket-outlets
3120	Approval and test specification—Cord extension sockets
3123	Approval and test specification—Plugs, socket-outlets and couplers for general industrial application
3190	Approval and test specification—Residual current devices (current-operated earth-leakage devices)
3191	Electric flexible cords
3199	Approval and test specification—Cord extension sets
3760	In-service safety inspection and testing of electrical equipment

AS/NZS	
3439	Low-voltage switchgear and controlgear assemblies
3439.4	Part 4: Particular requirements for assemblies for construction sites (ACS)
4763(Int)	Safety of portable inverters
4836	Safe working on low-voltage electrical installations
5000	Electrical cables—Polymeric insulated (all parts)
60598 Luminaires	
60598.2.8	Part 2.8: Particular requirements—Handlamps
60898	Electrical accessories—Circuit-breakers for overcurrent protection for household and similar applications
60898.1	Part 1: Circuit-breakers for a.c. operation
60898.2	Part 2: Circuit-breakers for a.c. and d.c. operation
61008	Residual current operated circuit-breakers without integral overcurrent protection for household and similar uses (RCCBs)
61008.1	Part 1: General rules
61009	Residual current operated circuit-breakers with integral overcurrent protection for household and similar uses (RCBOs)
61009.1	Part 1: General rules
61558 Safety of power transformers, power supply units and similar devices	
61558.2.23	Part 2.23: Particular requirements for transformers for construction sites
IEC	
60309	Plugs, socket-outlets and couplers for industrial purposes (all parts)
OTHER	
BCA	Building Code of Australia

APPENDIX B
ELECTRICAL INSTALLATIONS IN THE DOMESTIC HOUSING
CONSTRUCTION INDUSTRY

(Normative)

B1 GENERAL

Conditions in the domestic housing construction industry differ to those experienced during commercial construction. This Appendix has been added to highlight areas where this Standard can be varied for certain types of domestic housing construction. These types of domestic housing construction are defined as Classes 1, 2 and 10.

The BCA classification of buildings also applies in New Zealand.

NZ

NOTE: See Appendix C.

Variations are listed below, with any clarification or alternative arrangements.

B2 SPECIFIC CLAUSE VARIATIONS

For a single domestic residence intended to be occupied as a residential housing unit, or adjoining units each with a separate exterior entry and intended to be occupied as residential housing units, the requirements of this Standard are varied as listed for the following clauses in Section 2 of this Standard:

2.3.1.2 Distribution boards

Delete the requirement for a distribution switchboard on each level.

2.6.8 Limitations on the use of cord extension sets

Delete (a) and replace with:

When used in domestic housing construction, be confined to not more than one storey up or down from the storey of the switchboard from which they originate and be mechanically protected in accordance with AS/NZS 3000 at the transition between storeys and in places where damage is likely to occur.

APPENDIX C
CLASSIFICATION OF BUILDINGS AND STRUCTURES
(Informative)

C1 PRINCIPLES OF CLASSIFICATION

The classification of a building or part of a building is determined in the Building Code of Australia (BCA) by the purpose for which it is designed, constructed or adapted to be used.

The classifications listed below are taken directly from the BCA.

For the purposes of this Standard, Classes 1, 2 and 10 below are considered to be domestic housing construction.

C2 CLASSIFICATIONS

Buildings are classified as follows:

- (a) *Class 1*—one or more buildings that in association constitute—
 - (i) *Class 1a*—a single dwelling being—
 - (A) a detached house; or
 - (B) one of a group of two or more attached dwellings, each being a building separated by a fire resisting wall, including a row house, terrace house, town house or villa unit; or
 - (ii) *Class 1b*—a boarding house, guest house, hostel or the like
 - (A) with a total area of all floors not exceeding 300 m² measured over the enclosing walls of the Class 1b building; or
 - (B) In which not more than 12 persons would ordinarily be resident;

which is not located above or below another dwelling or another Class of building other than a private garage.
- (b) *Class 2*—a building containing two or more sole-occupancy units each being a separate dwelling.
- (c) *Class 3*—a residential building, other than a building of Class 1 or 2, which is a common place of long term or transient living for a number of unrelated persons, including—
 - (i) a boarding house, guest house, hostel, lodging house or backpackers accommodation; or
 - (ii) a residential part of a hotel or motel; or
 - (iii) a residential part of a *school*; or
 - (iv) accommodation for the aged, children or people with disabilities; or
 - (v) a residential part of a *health-care building* that accommodates members of staff, or
 - (vi) a residential part of a *detention centre*.
- (d) *Class 4*—a dwelling in a building that is Class 5, 6, 7, 8 or 9 if it is the only dwelling in the building.
- (e) *Class 5*—an office building used for professional or commercial purposes, excluding buildings of Class 6, 7, 8 or 9.

- (f) *Class 6*—a shop or other building for the sale of goods by retail or the supply of services direct to the public, including—
 - (i) an eating room, café, restaurant, milk or soft-drink bar; or
 - (ii) a dining room, bar area that is not an *assembly building*, shop or kiosk part of a hotel or motel; or
 - (iii) a hairdresser's or barber's shop, public laundry or undertaker's establishment; or
 - (iv) a market or sale room, showroom or service station.
- (g) *Class 7*—a building that is—
 - (i) *Class 7a*—a *carpark*; or
 - (ii) *Class 7b*—for storage or display of goods or produce for sale by wholesale.
- (h) *Class 8*—a laboratory or a building in which a handicraft or process for the production, assembling, altering, repairing, packing, finishing or cleaning of goods is carried on for trade, sale or gain.
- (i) *Class 9*—a building of a public nature—
 - (i) *Class 9a*—a health care building, including those parts of the building set aside as a laboratory; or
 - (ii) *Class 9b*—an assembly building, including a trade workshop, laboratory or the like in a primary or secondary school, but excluding any other parts of the building that are of another Class; or
 - (iii) *Class 9c*—an aged care building.
- (j) *Class 10*—a non-habitable building or structure—
 - (i) *Class 10a*—a non-habitable building being a *private garage*, carport, shed or the like; or
 - (ii) *Class 10b*—a structure being a fence, mast, antenna, retaining or free-standing wall, *swimming pool* or the like.

APPENDIX D
REGULATORY APPLICATION ON CONSTRUCTION AND
DEMOLITION SITES

(Informative)

D1 GENERAL

Compliance with this Standard is a requirement of AS/NZS 3000.

Relevant regulatory authorities in the Australian States and Territories and in New Zealand require compliance with this Standard under their various regulatory instruments and may also provide requirements in addition to this Standard in relevant legislation or Industry Codes of Practice.

The purpose of this Appendix is to provide details of the relevant authorities that enforce regulations on electrical installations of construction and demolition sites in each of the Australian States and Territories and in New Zealand.

This information is accurate at the time of publication of this Standard. Users are advised to consult the relevant nominated regulatory authority for information current at the time of use.

D2 REGULATORY AUTHORITIES AND REGULATORY INSTRUMENTS

D2.1 New South Wales

WorkCover NSW, as the State OHS Regulator, applies regulation to electrical installations at construction and demolition sites.

WorkCover NSW has adopted AS/NZS 3012 (this Standard) under its '*Code of Practice—Technical guidance*'. The Code provides practical guidance for NSW employers and other persons in meeting their obligations under the Occupational Health and Safety Regulations 2001.

An earlier NSW Code of Practice, '*Electrical practices for construction work*' also covers the verification (inspection and testing) of electrical installations and electrical equipment on construction sites. In the event of any inconsistencies between AS/NZS 3012 and the Code of Practice, the NSW Code prevails.

Contact details:

WorkCover NSW

Information Centre: Phone: 13 10 50

Head office:

92-100 Donnison Street
GOSFORD NSW 2250

Postal address:

Locked Bag 2906
LISAROW NSW 2252

Telephone: (02) 4321 5000

Facsimile: (02) 4321 4145

Website: www.workcover.nsw.gov.au

The NSW Department of Primary Industries, Mine Safety Operations is the OHS Regulator for NSW Mines. Compliance to AS/NZS 3000 is mandatory in mining legislation. AS/NZS 3012 is normative a reference within AS/NZS 3000.

Contact details:

NSW Department of Primary Industries, Mine Safety Operations
516 High Street
MAITLAND NSW 2320

Postal address:

PO Box 344
HUNTER REGION MAIL CENTRE NSW 2310

Telephone: (02) 4931 666

Facsimile: (02) 4931 6790

Website: www.dpi.nsw.gov.au

D2.2 Victoria

In Victoria regulation of electrical installations on construction and demolition sites is a joint responsibility of Energy Safe Victoria [ESV] and WorkSafe Victoria [WorkSafe].

AS/NZS 3000 is called up by the Electricity Act 1998 and the Electricity (Installation) Regulations 2009. AS/NZS 3012 is given the status of a mandatory compliance document in AS/NZS 3000.

WorkSafe is responsible for regulating the Occupational Health and Safety Act and Regulations

Victoria also has an Industry Guideline that provides advice on compliance to this Standard. Some construction sites may have requirements in addition to the minimum safety requirements set out in this Standard.

Contact details:

Energy Safe Victoria
Level 3
4 Riverside Quay
SOUTHBANK VIC 3006

Postal address:

PO Box 262
COLLINS STREET WEST VIC 8007

Telephone: (03) 9203 9700

Facsimile: (03) 9686 2197

Website: www.esv.vic.gov.au

WorkSafe

WorkSafe Advisory Service 1800 136 089

WorkSafe Incident Notification 132 360

Website: www.worksafe.vic.gov.au

D2.3 Queensland

In Queensland, the Electrical Safety Office and Workplace Health and Safety have regulatory responsibility for electrical installations on construction and demolition sites.

Contact details:

Electrical Safety Office
Level 16, State Law Building
50 Ann Street
BRISBANE QLD 4001

Postal address:

GPO Box 69
BRISBANE QLD 4001

Telephone: 1300 362 320

Facsimile: (07) 3237 9890

Website: www.eso.qld.gov.au.

D2.4 Australian Capital Territory

ACT Department of Urban Services through the ACT Building Electrical and Plumbing Control (BEPCON) applies regulation of electrical installations on construction and demolition sites.

BEPCON calls up AS/NZS 3012 specifically in its 'Safe Demolition Work – ACT Code of Practice'.

Contact details:

BEPCON

Central Office
Ground Floor, North
Dame Pattie Menzies House
16 Challis Street
DICKSON ACT 2602

Telephone: (02) 6207 6400

Facsimile: (02) 6207 6324

Website: www.palm.act.gov.au/bepcon

D2.5 Tasmania

The Office of Electricity Standards and Safety has responsibility for electrical safety in Tasmania.

AS/NZS 3000 is called up by the Occupational Licensing (Standards of Electrical Works) Code of Practice established under Section 53 of the *Occupational Licensing Act 2005*. 'Electrical Installations (as defined) shall comply with AS/NZS 3012 in accordance with AS/NZS 3000'.

Electrical Work on construction and demolition sites is also subject to the terms of the *Workplace Health and Safety (WH&S) Act 1995*, which is administered by Workplace Standards Tasmania. The Workplace Health and Safety Regulations 1998 state that relevant codes and guidelines shall be used and AS/NZS 3012 is deemed to be the relevant code or guideline for electrical installations on construction and demolition sites.

Both the Office of Electricity Standards and Safety and Workplace Standards Tasmania are parts of the Department of Justice.

Contact details:

Workplace Standards Tasmania
30 Gordons Hill Rd
ROSNY PARK TAS 7018

Postal address:

PO Box 56
ROSNY PARK TAS 7018

Telephone: 1300 366 322

Facsimile: (03) 6233 8338

Website: www.wst.tas.gov.au

D2.6 Northern Territory

The Department of Employment, Education and Training through NT WorkSafe has jurisdiction over electrical installations on construction and demolition sites in the Northern Territory.

AS/NZS 3000, AS/NZS 3012 (this Standard) and AS/NZS 3100 are called up by the Work Health (Occupational Health and Safety) Regulations.

Subject to the regulations, all electrical installations, materials, equipment and apparatus at a workplace shall comply with AS/NZS 3000 and AS/NZS 3100.

Electrical installations on construction sites shall comply with AS/NZS 3012 (this Standard).

Contact details:

NT WorkSafe
First Floor
Darwin Plaza Building, The Mall
41 Smith Street
DARWIN NT 0800

Postal Address:

GPO Box 4821
DARWIN NT 0801

Telephone: (08) 8999 5010

Facsimile: (08) 8999 5141

Website: www.worksafe.nt.gov.au

D2.7 South Australia

In South Australia, the Office of the Technical Regulator (SA) has jurisdiction over electrical installations on construction and demolition sites.

AS/NZS 3000 is called up by the *Electricity Act 1996*, Electricity (General) Regulations 1997. AS/NZS 3012 (this Standard) is given the status of a mandatory compliance document in AS/NZS 3000.

Electrical Work on construction and demolition sites is also subject to the terms of the *Occupational Health, Safety and Welfare Act 1986* and the Occupational Health, Safety and Welfare Regulations 1995, which are administered by Safework SA.

Contact details:

Office of the Technical Regulator
Department for Transport, Energy and Infrastructure
L8, ANZ Building
11 Waymouth Street
ADELAIDE SA 5000
Telephone: (08) 8226 5518
Facsimile: (08) 8226 5529
Website: www.technicalregulator.sa.gov.au

Safework SA
Level 3
1 Richmond Road
KESWICK SA 5035
Postal Address:
GPO Box 465,
ADELAIDE SA 5001
Telephone: (08) 8303 0400
Facsimile: (08) 8303 0277
Website: www.safework.sa.gov.au

D2.8 Western Australia

In Western Australia, the Energy Safety Division of the Department of Consumer and Employment Protection (DOCEP) has jurisdiction over electrical installations on construction and electrical work generally.

AS/NZS 3000 is called up by the *Electricity Act 1945*, Electricity (Licensing) Regulations 1991 and the Electricity Regulations 1947. AS/NZS 3012 is given the status of a mandatory compliance document in AS/NZS 3000.

Electrical Work on construction and demolition sites is also subject to the terms of the *Occupational Safety and Health Act 1984* and the Occupational Safety and Health Regulations 1996, which are administered by WorkSafe Western Australia, which is also a Division of DOCEP.

Contact details:

Energy Safety

303 Sevenoaks St (corner Grose Ave)
CANNINGTON WA 6107

Telephone: (08) 9422 5200

Facsimile: (08) 9422 5244

Website: www.energysafety.wa.gov.au

Work Safe Western Australia

5th Floor

1260 Hay Street

WEST PERTH WA 6005

Postal address:

PO Box 294

WEST PERTH WA 6872

Telephone: (08) 9327 8777

Facsimile: (08) 9321 8973

Website: www.safetyline.wa.gov.au

APPENDIX E
MARKING OF SWITCHBOARDS TO INDICATE THE PRESENCE
OF LIVE PARTS

(Normative)

Where access to live parts is required, the following symbolic electric shock risk sign shall be displayed in locations where additional attention is required to be given to the removal of covers and the like.



In addition, a DANGER sign as illustrated below, with an additional message, for example, indicating the presence of live parts within, should be conspicuously displayed on the enclosure of the ASSEMBLY to alert persons to the hazard.

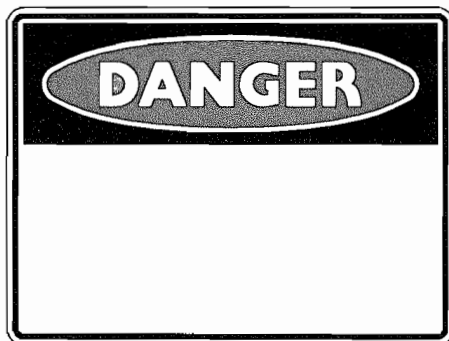

APPENDIX F
RECOMMENDED COLOURS FOR TAGS ON TESTED EQUIPMENT

(Informative)

This Appendix gives a recommended colour coding schedule for tags on tested equipment. The tag should indicate by its colour the period in which the test was performed in accordance with the following schedule:

- (a) *Red* December–February.
- (b) *Green* March–May.
- (c) *Blue* June–August.
- (d) *Yellow* September–November.

NOTE: Some construction sites will not allow the use of equipment on site unless the tag colour readily indicates the required retest date in accordance with Table 3. The colours shown above apply to 3-monthly requirements.

APPENDIX G

ELECTRICAL VERIFICATION OF GENERATORS WITH RCD PROTECTION
TO AS/NZS 3012 AND AS/NZS 3760

(Normative)

G1 PRIOR TO INTRODUCTION TO SERVICE ON SITE AND AT INTERVALS IN ACCORDANCE WITH CLAUSE 3.2

- (a) Inspection shall be performed in accordance with the relevant requirements of AS/NZS 3760.
- (b) Testing of earth continuity and equipotential bonding shall be performed in accordance with AS/NZS 3760, with the generator not running. The resistance shall not exceed 1Ω from the socket E, to the stator, to the frame and to the socket N, with the RCD closed.

NOTE: Insulation resistance is not tested, due to the neutral-earth connection.

- (c) RCD operation and correct connection shall be verified to Clause 3.5 and the relevant requirements of AS/NZS 3760 with the generator running. The following requirements shall be met:
 - (i) When the test button is pushed, the RCD shall trip without undue delay; and
 - (ii) When tested at 30 mA, the RCD shall trip within 300 ms.

G2 PRIOR TO EACH USE AND AT LEAST ONCE PER DAY

The test button shall be pushed and the RCD shall trip without undue delay.

APPENDIX H
ELECTRICAL VERIFICATION OF PORTABLE INVERTERS
(Normative)

H1 MARKING AND DOCUMENTATION

All inverters that meet AS/NZS 4763(Int) requirements shall be marked by the words or a graphical symbol to identify the applicable installation situation as follows:

- (a) Isolated inverters shall be identified by the words 'isolated inverter' or the diagram in Figure H1.1 on the inverter:

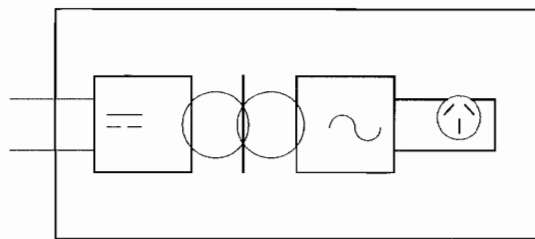

FIGURE H1.1 ISOLATED INVERTER

- (b) RCD protected inverter identification and documentation:

- (i) RCD protected inverters shall be identified by the words 'RCDP inverter' or the diagram in Figure H1.2 on the inverter:

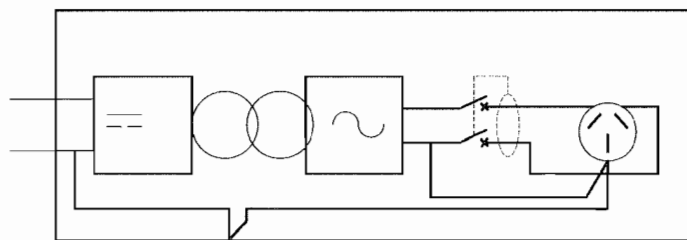

FIGURE H1.2 RCDP INVERTER

- (ii) Inverters that have been retrofitted with an RCD shall have documentation verifying compliance with AS/NZS 4763(Int) as follows:
- (A) *Clause 3.1.5* Bonding connections (see Paragraph H2).
 - (B) *Clause 15.12* The RCD is integral (cannot be removed without the use of a tool) and the RCD has been tested for both a.c. and d.c. pulse residual current.
 - (C) *Clause 16.10* The RCD is Type A.

H2 VERIFICATION OF INVERTER SEPARATION AND RCD OPERATION

H2.1 General

This Paragraph (H2) details tests for the verification of the electrical separation in isolated inverters and for verification of the bonding and RCD operation in RCD protected inverters.

All tests shall be performed prior to the introduction of all inverters into service and at intervals as specified in Paragraph H3.

H2.2 Electrical separation for isolated inverters

The inverter is connected to the rated supply voltage with no load and then with a load connected to the output circuit.

A true rms reading volt meter, along with a parallel resistor, is connected from the battery negative terminal to each of the following:

- (a) The socket-outlet Active contact.
- (b) The socket-outlet Neutral contact.

The voltage shall not exceed 25 V.

NOTE: The parallel resistor is to ensure the voltages are from a source with a sufficiently low value of impedance that is capable of delivering a perception current to a person. A resistor in the range 1.5 k Ω to 15 k Ω is suitable.

H2.3 Bonding and RCD operation for RCD protected inverters

H2.3.1 Bonding test

The continuity is measured to ensure the battery negative, the inverter frame and the socket-outlet earth contact are connected together.

The value of resistance shall not exceed 1 Ω .

H2.3.2 RCD test

The inverter is connected to the rated supply voltage with no load and then with a load connected to the output circuit.

- (a) *Functional test with the RCD test button* The button is pushed to initiate a trip of the RCD. The RCD must trip without undue delay. The test is made 5 times.
- (b) *Residual current rating* Operation at the rated residual current using a test resistor and verification that the neutral-earth (or centre tap) connection is upstream of the RCD.

A resistor in series with a switch is connected from the socket-outlet active terminal to the socket-outlet earth terminal. The RCD is closed and then the test switch is closed.

The RCD must trip without undue delay. The test is made 5 times.

NOTES:

- 1 The resistor is sized to give the rated residual current. For example, with a 230 V true rms output with a rated residual current of 30 mA, the resistor should be 7.6 k Ω . Other values are given in the notes to Figure H2.
- 2 If an RCD tester is used it must be verified by the supplier as suitable for the output waveform of the inverter.

H3 PERIODIC TESTING INTERVALS

Testing intervals shall be in accordance with Clause 3.2 and Table 3

Isolated inverters and equipotentially bonded inverters are tested at intervals as specified for Class II portable devices.

RCD protected inverters are tested at intervals as specified for portable RCDs.

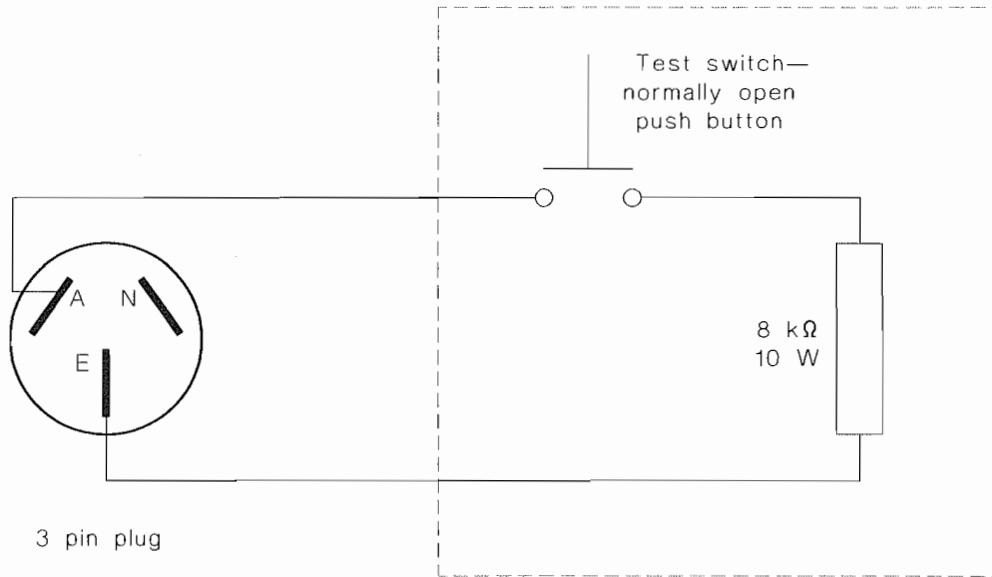

If the test box is metallic it should be connected to earth

NOTE: For a rated residual current of 30 mA the values of the resistor are as follows:

For 230 V true rms output..... 7.6 kΩ

For 240 V true rms output..... 8 kΩ

For 120/120 V centre tap 4 kΩ

FIGURE H2 RESIDUAL CURRENT TEST BOX (RESISTOR SIZED FOR 240 V rms)

APPENDIX 1
 NEW ZEALAND ONLY
 VERIFICATION FORM FOR CONSTRUCTION AND DEMOLITION SITES
 (Normative)

11 INTRODUCTION

11.1 Verification

There are mandated requirements in the NZ Electricity (Safety) Regulations 2010 for the verification of Construction and Demolition sites at the intervals detailed in Table 3 to the requirements of AS/NZS 3000 and the additional requirements of AS/NZS 3012 (this Standard). The NZ Electrical Workers Licensing Board should be consulted for the competency requirements for those persons carrying out inspections.

This Appendix provides a suitable form for this verification. This form may be copied for production of forms.

11.2 Verification form

CERTIFICATE OF VERIFICATION
Construction and demolition site details:
Client:
Address of construction and demolition site:
.....
.....
This certificate covers verification of Construction site/Demolition site (delete as required):
.....
.....
.....
Verification:
I have carried out a verification of the above site in accordance with AS/NZS 3000 and the additional requirements of AS/NZS 3012 and certify that the installation meets the requirements detailed for the issue of a Certificate of Verification
Name of person who carried out inspection:
Registration type and number:
.....
Signature:.....
Date: / /20

APPENDIX J

GUIDE TO ARRANGEMENT OF SWITCHBOARDS,
CONSTRUCTION WIRING AND EQUIPMENT

(Normative)

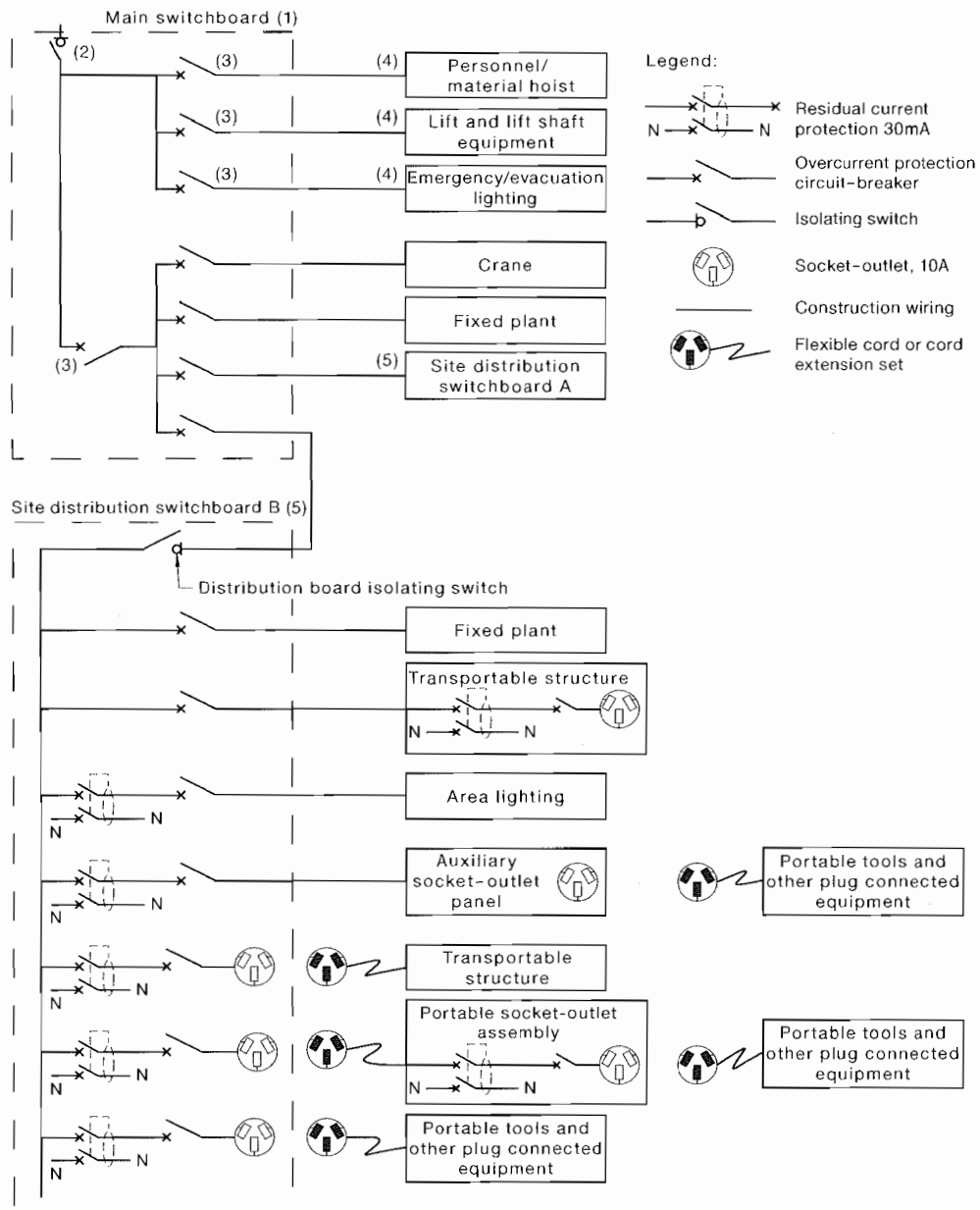

NOTES:

- 1 Safety services shall comply with the requirements of the Wiring Rules.
- 2 If safety services are supplied downstream of this switch, then this switch shall be locked in the on position and marked **Isolating switch—operation by authorized persons only**. If there are no safety services this is the main switch.
- 3 Main switch if switch (2) is not provided.
- 4 Safety service.
- 5 Only the main switchboard may supply safety services.

FIGURE J1 GUIDE TO ARRANGEMENT OF SWITCHBOARDS CONSTRUCTION
WIRING AND EQUIPMENT

APPENDIX K

ALTERNATIVE SUPPLY SYSTEM FOR CONSTRUCTION AND DEMOLITION SITES

(Normative)

K1 SCOPE

This Appendix covers information and additional requirements for the use of Assemblies for Construction Sites (ACS) complying with AS/NZS 3439.4 as an alternative supply system for construction and demolition sites.

This Appendix provides further information to supplement that covered in Clause 2.3.2.

NOTE: This Appendix uses the AS/NZS 3439.4 term 'Assemblies for Construction Sites'. These units may be known by the term 'Cascadable Reticulation Units' (CRU) in other Standards, e.g. AS/NZS 3002.

K2 ALTERNATIVE SUPPLY SYSTEMS

K2.1 Installation and verification

- (a) Australia and New Zealand require a qualified person for the installation and verification of direct connected sub-mains and equipment
- (b) Australia requires a qualified person for the installation and verification of sub-mains (interconnecting cable) for plug and socket connected ACSs. A
- (c) New Zealand requires a competent person for the installation and verification of sub-mains (interconnecting cable) for plug and socket connected ACSs. NZ

K3 GENERAL REQUIREMENTS AND FUNCTIONS OF ASSEMBLIES FOR CONSTRUCTION SITES (ACS)

K3.1 General

All ACS shall comply with the requirements of AS/NZS 3439.4 and the relevant requirements of this Standard.

K3.2 ACS description

An ACS system consisting of an incoming ACS unit and several outgoing ACS units is shown in Figure K1. Safety services shall be installed to the requirements of AS/NZS 3000.

The interconnecting cables are classified as sub-mains and may use direct or detachable connections. The circuits within the units supplying socket-outlets and/or major items of plant are classified as final sub-circuits.

Incoming and outgoing ACS units may incorporate additional units such as—

- (a) metering units;
- (b) transformer units with low voltage to extra low voltage (LV/ELV) transformers to provide SELV or PELV supplies; and
- (c) transformer units with low voltage to low voltage (LV/LV) transformers to provide separated (isolated) LV supplies.

An outgoing ACS unit may provide a supply to—

- (i) other ACS outgoing units;
- (ii) lighting;

- (iii) machines or electric tools; or
- (iv) other construction site equipment.

K3.3 ACS installation system

A number of compatible ACS assemblies may be interconnected to form a complete installation, or part of an installation. ACS assemblies shall provide basic protection (protection against direct contact) from electric shock and, where possible, discrimination by suitable selection of protective devices. For example, the breaking capacity, current rating and operating time under fault conditions.

In Australia only, on the incoming supply function unit for each floor of a multi-storey construction the detachable incoming supply connections (both ends) shall be fitted with a device requiring a key or tool for disconnection (detachment) and all other ACS units connected to this unit shall be limited to that floor.

A

Exception: This requirement need not apply to work in lift shafts, stairwells, service shafts, formwork or external staging.

K3.4 Assembly characteristics

The various assembly characteristics are laid down by the manufacturer, or are the subject of an agreement between manufacturer and user, taking into account the nature of supply and/or distribution network and relevant installation requirements. A single ACS assembly may incorporate a number of functions.

K4 GENERAL CLASSIFICATION OF ACS ASSEMBLIES

K4.1 Transportable ACS unit

Assemblies that are intended for use in a place where they are not permanently fixed and the location may vary during work on the site. When the transportable ACS is to be moved to another location, it must be disconnected from the supply.

K4.2 Mobile ACS unit

Assemblies that are capable of being moved as work advances on the site. These may not require disconnection from the supply when being relocated.

K4.3 Incoming ACS unit

- (a) The cable connection facilities, terminals, connecting devices, connectors, or plug and socket-outlet accessories shall be compatible with the current rating of the ACS assembly.
- (b) Incoming and outgoing isolating and over-current protective devices shall be provided. There shall be means for securing these devices in the open position. The protection shall be sized to ensure that, with the maximum earth fault loop impedance to a socket-outlet on the most distant ACS, automatic disconnection of supply occurs within 400 ms as per AS/NZS 3000, i.e. fault protection for indirect contact is ensured.
- (c) The incoming ACS assembly is typically a transportable ACS.
- (d) The cabling to an incoming ACS shall be by direct connection.
- (e) The connection to major items of plant shall be by direct connection from an incoming ACS unit.

K4.4 Metering ACS unit

- (a) The metering ACS assembly shall be designed by or in agreement with the electricity distributor requirements if it is intended to use the metering device(s) to measure the energy consumed for the purposes of payment for the energy consumed.

- (b) The metering ACS assembly is typically a transportable ACS.
- (c) The sub-main cabling to a metering ACS shall be by direct connection.

K4.5 Transformer ACS unit

K4.5.1 General

The transformer ACS unit includes a low-voltage to extra low-voltage (LV/ELV) transformer and/or a low-voltage to low-voltage transformer (LV/LV).

K4.5.2 LV/ELV ACS unit

- (a) The LV/ELV ACS unit provides either a SELV or PELV supply complying with AS/NZS 3000 requirements.
- (b) Each LV/ELV ACS unit consists of—
 - (i) the protective and control devices in the transformer primary circuit;
 - (ii) a ELV safety transformer complying with the requirements of AS/NZS 61558; and
 - (iii) the protective devices, control switches and connection methods required for the ELV output circuits as detailed in AS/NZS 3000.
- (c) The LV/ELV ACS unit is typically a mobile ACS.

K4.5.3 LV/LV ACS unit

- (a) The LV/LV ACS unit provides a separated (isolated) LV supply complying with AS/NZS 3000 requirements.
- (b) Each LV/LV ACS unit consists of—
 - (i) the protective and control devices on the transformer primary circuit;
 - (ii) an LV/LV transformer, which shall be an isolating transformer complying with AS/NZS 61558; and
 - (iii) the protective and control devices for the output circuit(s) and socket-outlets shall be to AS/NZS 3000 requirements.
- (c) The equipotential bonding of socket-outlet earth connections supplied by a common isolating transformer secondary winding shall be to AS/NZS 3000 requirements.
- (d) The LV/LV ACS unit is typically a mobile ACS.

K4.6 Outgoing ACS unit

- (a) The outgoing ACS unit consists of one incoming and a number of outgoing circuits.
- (b) There shall be over-current protection, suitable for isolation, for the incoming and outgoing supply.

Exception: The incoming over-current protection may be omitted if the ACS assembly is directly connected to an upstream ACS assembly that is able to provide the overcurrent protection required for the downstream ACS assembly. However, a load break isolator on the incoming supply is still required.

- (c) The input isolation switch device shall be easily accessible without the use of a key or tool.
- (d) The input isolation switch shall operate simultaneously on all poles and switch all active conductors.

- (e) Additional protection of final sub-circuits shall comply with Clause 2.4.6 and 2.9.

NOTES:

- 1 To avoid unwanted tripping because of leakage currents and transient disturbances, care should be taken to ensure the sum of the leakage currents of electrical equipment on the load side of an RCD is significantly less than its rated residual current. RCDs may operate at any value of residual current in excess of 50% of the rated residual current.

It is recommended the loading of the circuit should be such that the leakage current does not exceed one third of the tripping current.

- 2 To avoid excessive leakage current causing unwanted tripping where socket-outlets are protected by one RCD having a rated residual current not greater than 30 mA, consideration should be given to the number of socket-outlets protected and the nature of electrical equipment likely to be connected to the socket-outlets.
- 3 Where RCDs are used, consideration should be given to the nature of the load, for example, the supply waveform shape and the presence of high frequency and/or d.c. components for the selection of the correct type of RCD.

- (f) In New Zealand the all RCDs shall be type A. NZ

- (g) Final sub-circuits supplying socket-outlets shall be provided with overcurrent protection rated suitable for that final sub-circuit. An overcurrent protective device may protect more than one socket-outlet.

NOTE: Consideration should be given to effects of unintended tripping, when an overcurrent protective device protects multiple socket-outlets.

- (h) The outgoing ACS unit is typically a mobile ACS.

K5 Interconnecting cables

K5.1 General

The sub-mains (interconnecting cables) of an ACS system are construction wiring and the requirements of Clause 2.5.3 for the provision of additional mechanical protection apply.

In addition, detachable sub-mains (interconnecting cables) of an ACS system shall also be screened cables, with the screen being earthed.

NOTE: This provides protection against physical mechanical damage from sharp objects, or in the case of the interconnecting cable being mechanically damaged by crushing or being cut, provides additional protection by the automatic disconnection of the supply by operation of the protective device protecting the cable.

K5.2 Connections

Direct or detachable connections may be used for sub-mains (interconnecting cables). See Clause K2.1

K5.3 Detachable sub-main, plugs, cord connectors and appliance inlets

Detachable sub-main plugs, cord connectors and appliance inlets shall comply with IEC 60309 or AS/NZS 3123 as agreed by the manufacturer and the user.

Devices for interconnection of sub-mains shall be rated at 32 A or above and be designed to prevent inadvertent disconnection under load.

K5.4 Distinction of sub-main sockets from other socket-outlets

The use of plug and socket-outlet systems commonly used on the site to supply electrical equipment shall not be used for the detachable connection of sub-mains.

K5.5 Overcurrent protection socket-outlets for detachable sub-mains

All socket-outlets used for the connection of detachable sub-mains shall be provided with overcurrent protection rated at equal to or less than the rating of the socket-outlets.

K5.6 Labelling

Fixed socket-outlets or cord extension sockets used for interconnecting cabling systems shall be identified as construction wiring and not suitable for electrical supply to hand held tools. The ACS units shall be clearly marked with instructions to isolate the unit before connection or disconnection of the sub-mains.

K6 INSTALLATION OF ACS ASSEMBLIES

K6.1 General

All ACS assemblies shall comply with Clause 2.3 and other relevant requirements. Detachable interconnecting cables shall be earth screened or armoured cables.

K6.2 Openings

Openings in ACS assemblies for cable entries, cover plates, etc. shall be such that, when the interconnecting cables, including their anchoring devices, are properly installed, the protective measures against contact with live parts and stated degree of IP protection is maintained.

K6.3 Interconnecting cables

Interconnecting cables shall be installed and protected to comply with Clause 2.5.

K6.4 Strain relief

Cables to and from ACS assemblies and connection facilities shall be suitably restrained to prevent undue stress on the interconnecting cable connections (see Clause 2.3.5).

K7 INITIAL AND PERIODIC VERIFICATION

K7.1 Initial verification

All ACS units and the detachable sub-main cabling systems, including fittings (if provided) shall be inspected, tested and tagged prior to use as per Clause 3.

Following completion of the assembly of the ACS system, the requirements of Section 3 for initial verification of construction wiring apply.

K7.2 Periodic verification

The requirements of Section 3 for periodic verification apply.

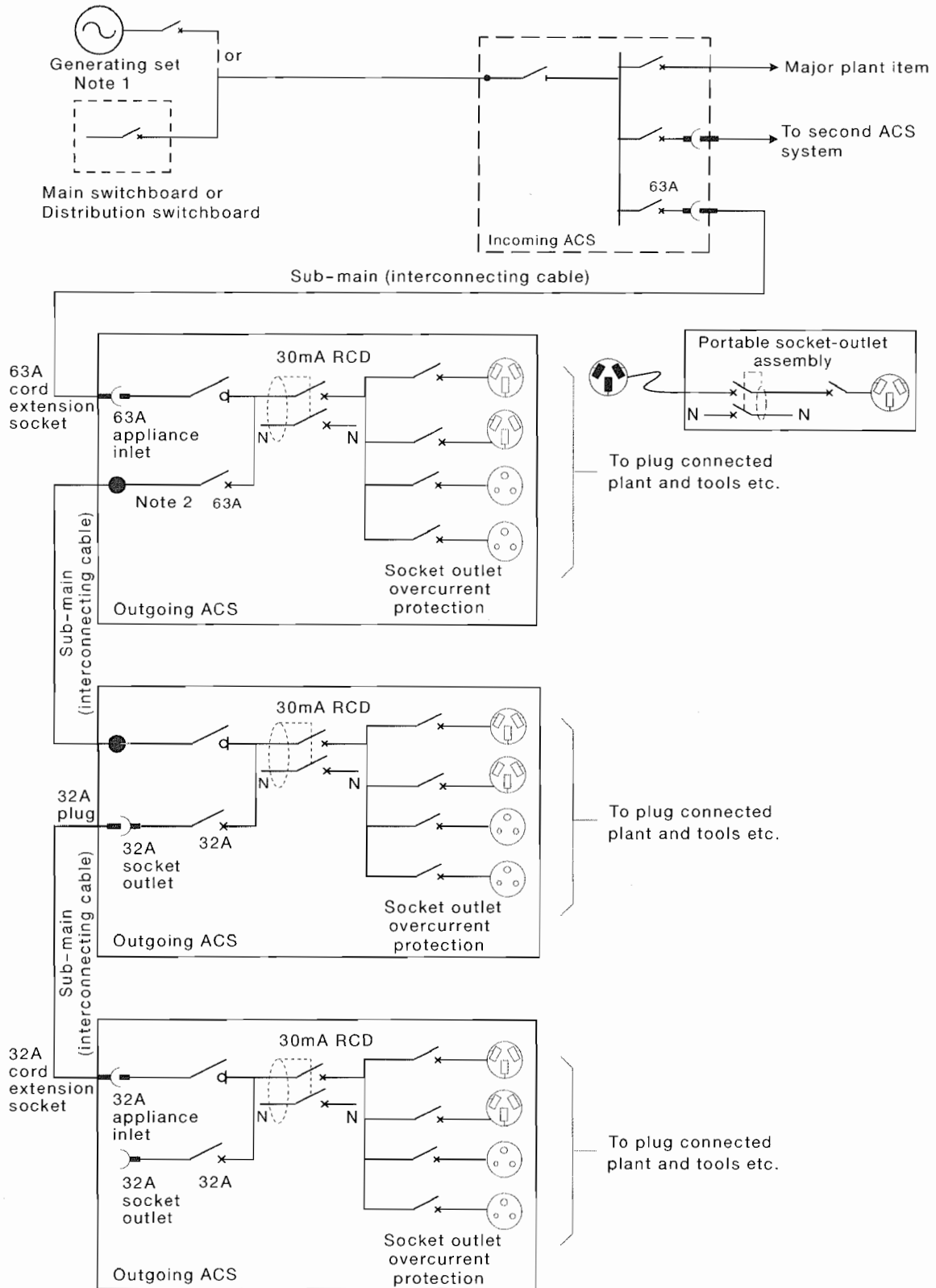

NOTES:

- 1 Generator set shall have the alternator star point connection bonded to the equipotential earthing system of ACS assemblies to ensure correct RCD operation.
- 2 This connection is shown as a direct connection for explanatory purposes only. Refer to Paragraph K5 for details.

FIGURE K1 GUIDE TO ARRANGEMENT OF SWITCHBOARDS, CONSTRUCTION WIRING AND EQUIPMENT

NOTES

Standards Australia

Standards Australia is an independent company, limited by guarantee, which prepares and publishes most of the voluntary technical and commercial standards used in Australia. These standards are developed through an open process of consultation and consensus, in which all interested parties are invited to participate. Through a Memorandum of Understanding with the Commonwealth government, Standards Australia is recognized as Australia's peak national standards body.

Standards New Zealand

The first national Standards organization was created in New Zealand in 1932. The Standards Council of New Zealand is the national authority responsible for the production of Standards. Standards New Zealand is the trading arm of the Standards Council established under the Standards Act 1988.

Australian/New Zealand Standards

Under a Memorandum of Understanding between Standards Australia and Standards New Zealand, Australian/New Zealand Standards are prepared by committees of experts from industry, governments, consumers and other sectors. The requirements or recommendations contained in published Standards are a consensus of the views of representative interests and also take account of comments received from other sources. They reflect the latest scientific and industry experience. Australian/New Zealand Standards are kept under continuous review after publication and are updated regularly to take account of changing technology.

International Involvement

Standards Australia and Standards New Zealand are responsible for ensuring that the Australian and New Zealand viewpoints are considered in the formulation of international Standards and that the latest international experience is incorporated in national and Joint Standards. This role is vital in assisting local industry to compete in international markets. Both organizations are the national members of ISO (the International Organization for Standardization) and IEC (the International Electrotechnical Commission).

Visit our web sites

www.standards.org.au

www.standards.co.nz

www.standards.com.au



STANDARDS

NEW ZEALAND

PAEREWA AOTEAROA

