

TRUSTED POWER OF ONE QUALITY  
BATH EXPERT PLUMBING HEALTHCARE  
ASSISTED LIVING  
DESIGNER SHOWER  
INNOVATION  
HOSPITALITY  
COMMITMENT  
SYSTEMS EXCELLENCE

DONE RIGHT RENOVATION

ARCHITECT SPEED TECHNOLOGY  
VALUE KITCHEN

**Oatey** COMMERCIAL

RELIABILITY COST SAVINGS  
NEW CONSTRUCTION  
ENGINEER  
SPECIFICATIONS

SOLUTION FASTER INSTALLATION

MULTI-FAMILY

BUILDER  
ADA COMPLIANT



# ENGINEERED TO INSPIRE. DESIGNED TO PERFORM.

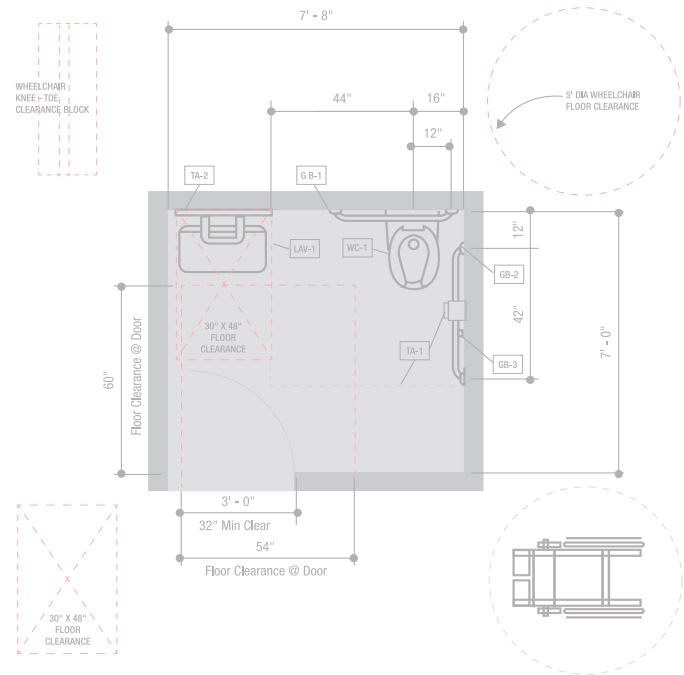

## ABOUT OATEY COMMERCIAL

Since 1916, Oatey has provided reliable, high-quality products for the residential and commercial plumbing industries. Today, Oatey operates a comprehensive manufacturing and distribution network to supply more than 6,000 products for professional builders, contractors, engineers and do-it-yourself consumers around the world. The company has successfully met customer needs for more than a century by offering innovative plumbing solutions that deliver results the first time. All Oatey products and brands are backed with the highest-quality technical and customer support programs in the industry.

Oatey Commercial is your powerful, single source to help you face the many challenges of construction. We offer a wide range of products and leading brands created specifically for architects, designers, and engineers to see their vision through.

From tubular, cements and sealants, to drains and testing products, Oatey Commercial delivers thousands of best-in-class products and the most trusted brands in the plumbing industry.

And it's all backed by over 100 years of manufacturing expertise and a knowledgeable customer service staff.

No two construction projects are the same. And the demands and requirements of a project are even more unique. It takes innovative solutions and an expert team to keep the project on time, on budget and built to rigorous specifications.

Trusted by plumbers for decades, Oatey consistently delivers superior product performance through strong partnerships, a spirit of innovation and a never-ending commitment to quality.



# RELIABLE PRODUCTS. TRUSTED BRANDS. EXPERT SUPPORT.

Oatey Commercial products are designed to meet the unique needs of hospitals, hotels, clinics, restaurants and any other facility in the commercial space. Decade after decade, our consistent approach has earned us the respect of builders, suppliers, architects and plumbers across the globe.

## TUBULAR

**Dearborn™** offers an expansive assortment of brass, plastic, and commercial tubular products. Whether it's P-Traps, Grab Bars, or ADA Safety Covers, Dearborn has you covered.

- Offering includes P-Traps, Tailpieces, Extension Tubes, Waste Arms, Center & End Outlet Wastes, Grab Bars, Trap Covers and much more.
- Dearborn products are offered in 1-1/4" & 1-1/2" variations, multiple gauges and different connection types depending on the job.
- Dearborn Safety Series ADA Compliant Tubular Covers are fast and easy to install while offering a long-lasting, clean appearance.



## PIPE PLUGS

**Cherne®** is the global leader in pipe plug and testing equipment. The Cherne Plumbing Test-Ball® plugs were designed to test drain, waste and vent systems and may be used in any type of pipe, inserted through a test tee, and seal out of round pipes.

- Cherne® Test-Balls
- Cherne® Clean-Seal Plugs
- Cherne® Long Test-Balls
- Cherne® Grippers



## THREAD SEALANTS

**Hercules®** has a diverse product line of thread sealants offering both soft and hard set formulations. We have products which are listed to FBC, CSA, and NSF to fulfill any application need.

- Hercules® Pro Dope
- Hercules® Real Tuff
- Hercules® Block
- Hercules® Megaloc



## AIR ADMITTANCE VALVES

**Oatey®** offers a wide range of Sure-Vent® Air Admittance Valves and accessories to enable installation in virtually any application.

- Oatey Sure-Vent® AAVs are available in four different sizes.
- Opens and closes as needed by building plumbing systems.
- Complies to ASSE Standard 1050 and 1051 and IAPMO listed sizes.



## DRAINS

Oatey® drains are offered for preformed showers, tile showers and floor drains in new construction and retrofit applications. QuickDrain USA™ products provide a wall-to-wall drain solution. A variety of finishes and configurations are available.

- Oatey® Shower & Floor Drains
- Oatey® Commercial Drains
- QuickDrain USA™



## HAMMER ARRESTORS

Oatey® Quiet Pipes® water hammer arrestors solve current and potential water hammer problems. When a valve is closed abruptly, the water moves into the pressurized chamber of the hammer and the water pressure is absorbed to prevent banging within the pipeline.

- A simple piston design delivers superior quality and ensures longer life.
- A wide variety of connection options are available, saving plumbers time and eliminating the need for costly transition joints.
- Oatey Quiet Pipes® water hammer arrestors carry a limited warranty that is equal in duration to the lifetime of the plumbing system in which they are installed.



## CEMENTS AND SEALANTS

Oatey® is the global leader and manufacturer of solvent cement. We proudly manufacture our products in the USA, and are committed to quality and consistency. Our assortment includes industrial primers and cements, in addition to unique formulations to address the needs of every solvent cement application.



## SUPPLY BOXES

Oatey® MODA® Supply Box System is designed to meet the needs of plumbing contractors for washing machine, ice maker, lavatory, toilet, dishwasher, secondary drain, Sure-Vent® Air Admittance Valve, and gas applications. A universal single box platform provides maximum versatility, installation simplicity and rugged reliability. MODA® Supply Box System is the ultimate solution for speed and flexibility.



## FLANGES

Oatey® flanges come in a wide variety of sizes, materials and configurations. PVC, Cast Iron, and ABS are available in both open and testable versions.

- Oatey® Level Fit Flanges
- Oatey® Easy Tap™ Flanges
- Oatey® Twist-N-Set® Replacement Flanges
- Oatey® Specialty Flanges





# DEARBORN

## CASE STUDY

### The Challenge

Veterans Village in Las Vegas desperately needed a new Crisis Intervention Center where U.S. military vets could drop in to get food, medical care, meal assistance, counseling and other assistance to help prevent homelessness and put vets on a positive path. The new center had to be easily accessible to the many vets who use wheelchairs. Without the budget for a new building, Veterans Village leaders asked for help to make the Crisis Intervention Center a reality.

### The Solution

The Las Vegas community responded enthusiastically, with more than 100 local companies and trade unions donating their expertise, materials and labor to the project.

The Dearborn ADA pipe wraps that Oatey donated to the project were a godsend for the plumbers, thanks to a simple and intuitive installation process. Made of EVA foam insulating material, the ADA pipe wrap conforms easily to 1¼" and 1½" tubular pipes, making it exceptionally fast and easy to install.

Commercial plumbers simply wrapped the product around the P-traps and supply lines under bathroom and kitchen sinks, snapped it into place, and used hook and loop fasteners to hold it in place. Then they cut the lightweight but heavy-duty wrap with scissors for a seamless fit.

### The Results

Veterans Village opened the new Crisis Intervention Center on Veterans Day, Nov. 11, 2017. Incredibly, the on-site construction that started Nov. 1 was completed Nov. 10, in a little over one week.

The ADA pipe wraps used throughout the building will also deliver immediate and long-term benefits for the center and the veterans it serves.

**“This center takes us to the next level instantly,” says Arnold Stalk, founder of Veterans Village. “It prevents the slide into homelessness and poverty, and it will help thousands of people a year.”**





# MODA™

## INFINITE SOLUTIONS

### What makes the Oatey MODA Modular Supply Box System so innovative?

Oatey designed the MODA box using extensive knowledge of the many plumbing problems that can occur on the job site. It's the most advanced system, supporting all your plumbing needs, including Standard, Fire-Rated and Gas.

### How does MODA box make a contractor's job easier?

Its universal single box platform provides maximum versatility, installation simplicity and rugged reliability, offering the ultimate in speed and flexibility. The MODA Supply Box System is designed to meet the needs of contractors for washing machine, ice maker, lavatory, toilet, dishwasher, secondary drain, Sure-Vent® Air Admittance Valve and gas applications.



FEATURE STORIES

**“What other systems missed, Oatey included.”**

## What are some of the unique features & benefits of the MODA box?

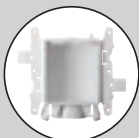

**Universal Single Box Platform** – Single faceplate is compatible with all box types so all boxes can snap to one another and common brackets can be used.



**Stronger, Simpler Connections** – Unique interlocking wing flanges accommodate on-stud, straddle-stud and three-box installations. Advanced design makes for easy installation and repositioning on the job.

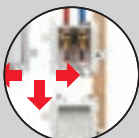

**Layout Versatility** – Separate valve and drain boxes allow paired or split boxes between walls or stud bays to prevent supply/drain crossovers.



**Tool-Free Test Plug** – Quarter-turn test plug with gasket provided means no knock outs falling into drains and no tools required.



**AAV Box Adapter** – Quarter-turn adapter with gasket maintains air-tight seal and can be retrofitted on any drain box.



**Easy Maintenance Valve with LocPin™** – Two-piece design makes valve replacement a snap, without damaging drywall.

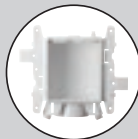

**Tough PVC Construction** – Stands up to the roughest job site abuse, and no transition cement needed when solvent welding PVC pipe.



**Intumescent Pad** 🔥 – Activated by heat and designed to expand, protecting the back of the box from extreme heat.



**Metal Brackets** 🔥 – Designed to provide additional support and hold in place under extreme temperatures.

# QUICKDRAIN

ELEGANT DESIGN · VERSATILE · FUNCTIONAL · COST-EFFECTIVE



QuickDrain includes innovative solutions for the drain body, shower pan and waterproofing, making it **the most complete and fastest-installing system on the market**. Boasting sophisticated detail and free of leaks or standing water, it's more than just a linear drain, **it's a total shower solution!**

## WallDrain

Built into the wall, offering a totally concealed and luxurious look.

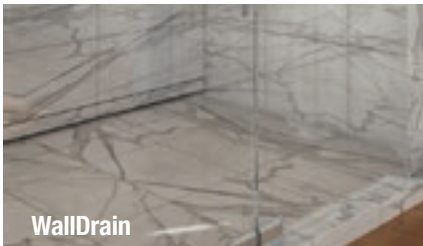

## ProLine

Made of 316L Stainless Steel and completely customizable. Perfect for construction jobs with spec requirements.



## ShowerLine

With a PVC drain body, it's the most cost-effective QuickDrain solution and is ideal for tub-to-shower conversions.



Every shower install is unique, but QuickDrain ensures each one is simple, fast and perfect. **Every time.**

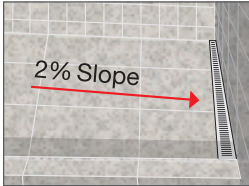

### One slope. No errors.

Instead of four different slopes toward the drain, QuickDrain requires just one. That means fewer chances of installer error.



### All in a matter of hours.

Traditional mud bed PVC pan liner jobs require a minimum two days of construction, waiting for mortar to set. The QuickDrain system can be completely installed in less than one day.



### Easy access.

Most retrofit drain systems need to access plumbing from the bathroom below, resulting in lost hotel revenue and a major inconvenience for residential applications. Its ability to work with existing plumbing makes QuickDrain the ideal choice for tub-to-shower conversions.

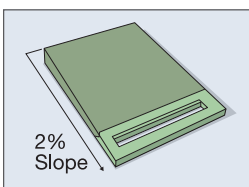

### Less labor.

The QuickDrain system allows installers to move on to the next job quickly. And, pre-sloped PET pans eliminate the need to float concrete, saving big on labor costs.

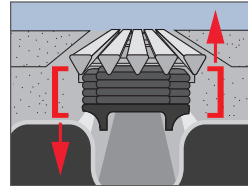

### Adjustable height.

Stackable spacers mean installers can easily adjust the drain cover after installation to ensure the cover is flush with the floor.

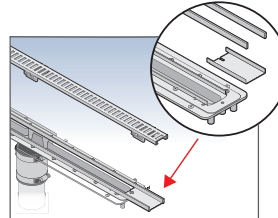

### Adjustable length.

Trough extensions and covers can be custom-trimmed at the jobsite after the body is installed, providing wall-to-wall coverage.

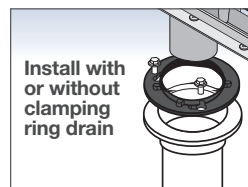

### Versatility.

ProLine and ShowerLine can be installed with or without a traditional style clamping ring.

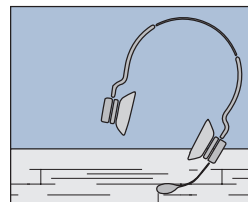

### Customer Service.

Training and customer service is our priority. We'll assist with design, ship directly to the job site and even send out a field tech for installation training.



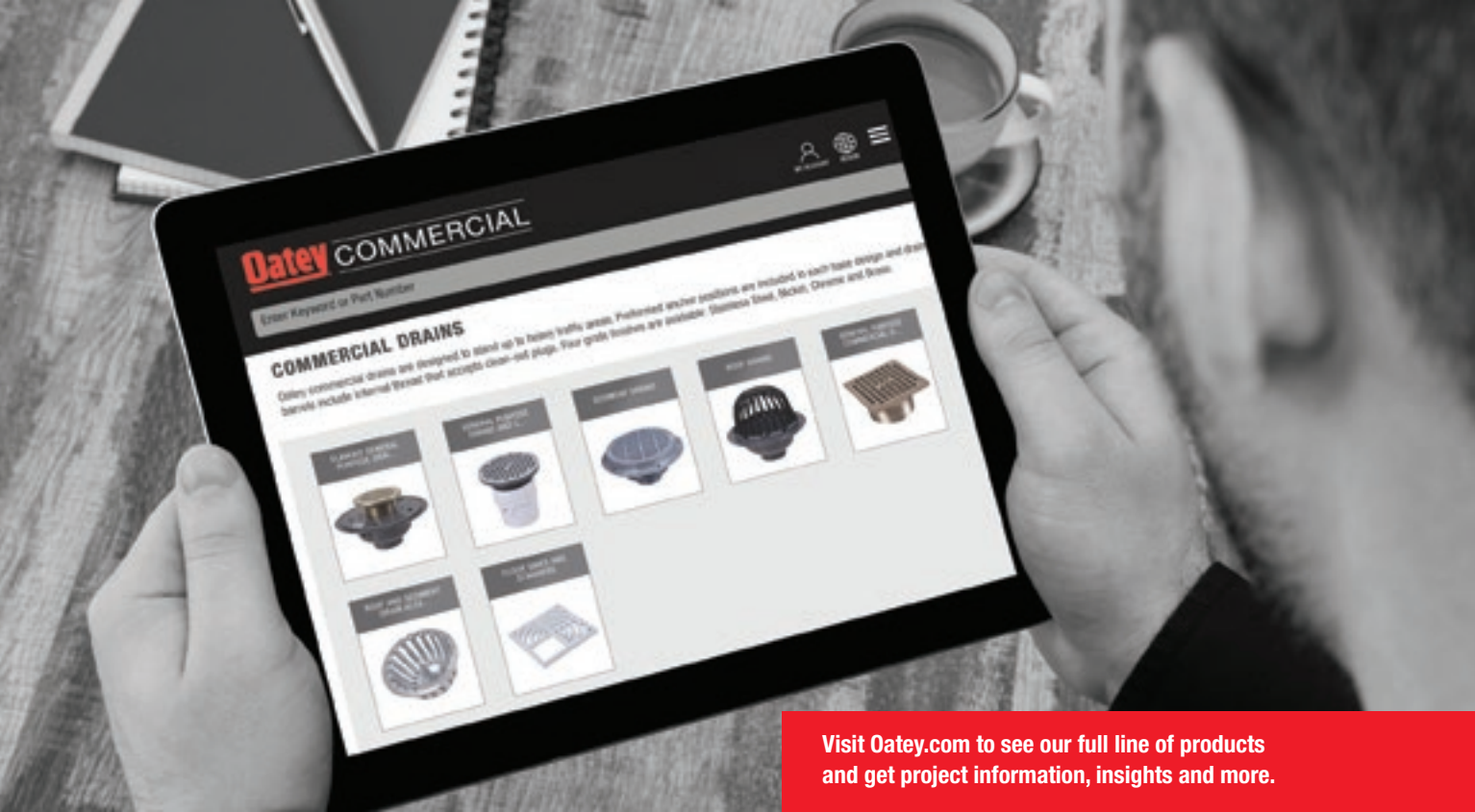

Visit [Oatey.com](http://Oatey.com) to see our full line of products and get project information, insights and more.



# STAY ON SCHEDULE, ON BUDGET AND ON TOP OF IT.

Doing a job right the first time requires reliable, quality plumbing products that are easy to use, save money and exceed customer expectations.

As the choice of plumbing professionals, Oatey has a rigorous quality management process for its products to ensure they meet the highest standards. We're committed to offering the industry's most reliable products and trusted brands, backed by industry-leading customer service and expertise built up over a century in the plumbing industry. In addition to innovative, reliable products, you'll get quick, professional answers to your questions to keep projects moving.

## PLAN. DESIGN. SPEC.

At Oatey, we know you need reliable products to keep projects running smoothly and that you require the most accurate information to specify products for your jobs. Visit [Oatey.com](http://Oatey.com) for detailed product descriptions, educational information, how-to videos, case studies and new product updates.

Plus, find the tools you need including:

- BIMObject
- MasterSpec
- ARCAT
- ARCOM
- 3-Part CSIs
- Specifications



### QUESTIONS?

Call 866-998-6685

Email [info@oateycommercial.com](mailto:info@oateycommercial.com)

For a complete list of Oatey Commercial parts, materials and design options, visit [Oatey.com](http://Oatey.com) or call 866.998.6685



LAVATORY SUPPLY  
TUBULAR SYSTEM

# SAFETY SERIES, BRASS TUBULAR AND GRAB BARS

EXPERT

NEAT AND CLEAN APPEARANCE

FASTER INSTALLATION

PROTECTS

FAST AND EASY

J-BEND COVER SET

ADA COMPLIANT MINIMIZES LIABILITY

DURABLE DESIGN

EVA FOAM

COVERS

ACCOMMODATES OFF-SET

HOOK & LOOP

ANY APPLICATION

LEAK FREE

SET TIME

180° OPENING

UNDER-LAVATORY

SECURE

EASY TO CUT AND TRIM

**Oatey** COMMERCIAL

BETTER FIT

WILL NOT YELLOW

FLEXIBLE

BROAD APPLICATION

DEARBORN DURABLE



# SAFETY SERIES, BRASS TUBULAR AND GRAB BARS

**BRASS, PLASTIC OR COMMERCIAL TUBULAR, DEARBORN  
HAS WHAT YOU'RE LOOKING FOR.**

The Dearborn Tubular offering includes P-Traps, Tailpieces, Extension Tubes, Waste Arms, Center End Outlet Wastes, Grab Bars and much more. No matter what size, material or configuration you need, Dearborn has what you need to get the job done right.



## ADA COMPLIANT LAVATORY TUBULAR COVERS - SAFETY SERIES

### SPECIFICATIONS

Design must open at 180° for easy installation and secure fit. Product shall be form fitting to provide a long lasting aesthetic look. Product shall be comprised of EVA foam material that will not fade or discolor over time, and its flexibility must allow for easy accommodation for a secure fit around supply line offsets. Product must accommodate both 1-1/4" and 1-1/2" tubular or cast brass p-traps as well as traps with and without cleanouts. Product must be certified antimicrobial per ISO 846 Method C. Valve cover securely encloses supply stop, but is easily removed when valve must be quickly closed.

PRODUCT NO.	DESCRIPTION	CTN. QTY.
<b>BRASS &amp; PLASTIC TUBULAR P-TRAP - STRAIGHT GRID DRAIN</b>		
ADA099	Universal Plastic & Brass P-Trap and Straight Grid Drain Cover Kit	10
ADA110	Universal P-Trap Full Cover Kit, Straight Grid Drain, Single Supply Line and Valve Cover	10
ADA101	Universal P-Trap Full Cover Kit, Straight Grid Drain, Two Supply Line and Valve Covers	10
<b>BRASS &amp; PLASTIC TUBULAR P-TRAP - OFFSET GRID DRAIN</b>		
ADA100	Universal P-Trap Full Cover Kit, Offset Grid Drain, Two Supply Line and Valve Covers	10



### APPROVALS & LISTINGS

IAPMO PS-94 - Insulated Protectors for P-Traps, Supply Stops, and Risers

ASTM C1822-2018 - Insulating Covers on Accessible Lavatory Piping

ASME A112.18.9 - Material and performance standard for exposed waste and supplies for public/commercial and private/residential buildings

ASTM E84 (25/450) - Surface Burning Characteristics

ASTM G21 & G22, ISO 846 Method C (Anti-fungal, Antibacterial, Antimicrobial)

Canada Barrier Free Code

### FEATURES & MATERIALS

#### Material:

EVA insulating Material

**Durometer:** Shore C

#### UV Resistance:

Will not fade or discolor

**Fastening:** Secure Fit

Hook and Loop

**Color:** White

**Maintenance:** Product can be cleaned with all common and industrial cleaning agents

**Painting:** Product can be painted with latex based coatings

**Trimming:** Easily trimmed with all common cutting tools (scissors, razor knife, shears, etc)

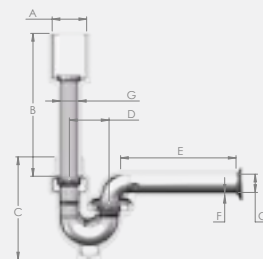

### UNIVERSAL DIMENSIONS:

**A:** 2.90"      **E:** 9.70"

**B:** 12.00"    **F:** 0.25"

**C:** 8.65"      **G:** 1.53"

**D:** 3.33"

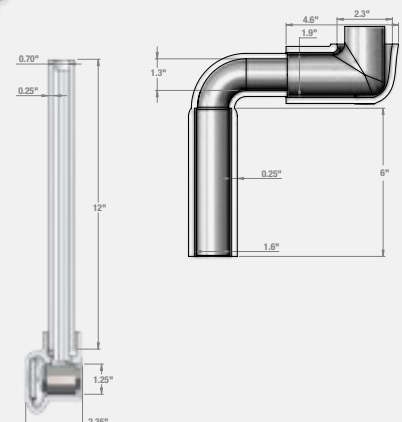



## ADA COMPLIANT LAVATORY TUBULAR COVERS - SAFETY SERIES

### SPECIFICATIONS

Design must open at 180° for easy installation and secure fit. Product shall be form fitting to provide a long lasting aesthetic look. Product shall be comprised of EVA foam material that will not fade or discolor over time, and its flexibility must allow for easy accommodation for a secure fit around supply line offsets. Product must accommodate both 1-1/4" and 1-1/2" tubular or cast brass p-traps as well as traps with and without cleanouts. Product must be certified antimicrobial per ISO 846 Method C. Valve cover securely encloses supply stop, but is easily removed when valve must be quickly closed.

PRODUCT NO.	DESCRIPTION	CTN. QTY.
<b>ACCESSORIES</b>		
ADA094	Single Supply and Valve Cover (1 Each)	10
ADA095	Wall Tube Extension Cover	10
ADA097	Offset Grid Drain Cover	10
ADA098	Two Supply and Valve Covers (2 Each)	10
<b>SCH 40 TUBULAR P-TRAP</b>		
ADA103	Schedule 40 P-Trap and Straight Grid Drain Cover Kit	10
ADA104	Schedule 40 P-Trap Full Cover Kit, Single Supply Line & Valve Cover	10
ADA105	Schedule 40 P-Trap Full Cover Kit, Two Supply Line & Valve Cover	10
<b>OFFSET WASTE ARM</b>		
ADA106	Universal Plastic & Brass Offset Waste Arm Cover Kit	10
<b>CENTER/END OUTLET WASTE</b>		
ADA107	Universal Plastic & Brass Center & End Outlet Waste Cover Kit	10
<b>SINK TRAP &amp; PLASTIC TUBULAR P-TRAP</b>		
ADA108	Universal Plastic & Sink Trap (Mass Code) and Straight Grid Drain Cover Kit	10
ADA111	Universal Plastic & Sink Trap (Mass Code) Full Cover Kit, Straight Grid Drain, Two Supply Lines & Valve Covers	10
ADA112	Universal Plastic & Sink Trap (Mass Code) Full Cover Kit, Offset Grid Drain, Two Supply Lines & Valve Covers	10

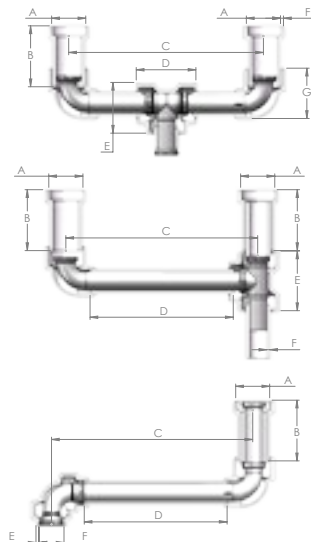

#### CENTER OUTLET DIMENSIONS:

A: 2.86"      E: 4.25"  
 B: 5.10"      F: 0.25"  
 C: 16.32"     G: 4.21"  
 D: 5.00"

#### END OUTLET DIMENSIONS:

A: 2.86"      D: 12.00"  
 B: 5.10"      E: 5.00"  
 C: 16.08"     F: 0.25"

#### WASTE ARM DIMENSIONS:

A: 2.86"      D: 12.00"  
 B: 5.10"      E: 0.25"  
 C: 16.90"     F: 2.10"



PNs ADA106 & ADA107 shown in use with ADA101

### APPROVALS & LISTINGS

IAPMO PS-94 - Insulated Protectors for P-Traps, Supply Stops, and Risers  
 ASTM C1822-2018 - Insulating Covers on Accessible Lavatory Piping  
 ASME A112.18.9 - Material and performance standard for exposed waste and supplies for public/commercial and private/residential buildings  
 ASTM E84 (25/450) - Surface Burning Characteristics  
 ASTM G21 & G22, ISO 846 Method C (Anti-fungal, Antibacterial, Antimicrobial)  
 Canada Barrier Free Code

### FEATURES & MATERIALS

**Material:**  
 EVA insulating Material  
**Durometer:** Shore C  
**UV Resistance:**  
 Will not fade or discolor  
**Fastening:** Secure Fit Hook and Loop  
**Color:** White

**Maintenance:** Product can be cleaned with all common and industrial cleaning agents  
**Painting:** Product can be painted with latex based coatings  
**Trimming:** Easily trimmed with all common cutting tools (scissors, razor knife, shears, etc)

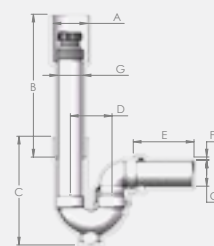

#### SCH 40 DIMENSIONS:

A: 2.90"      E: 5.10"  
 B: 12.00"     F: 0.25"  
 C: 9.13"      G: 2.20"  
 D: 3.50"

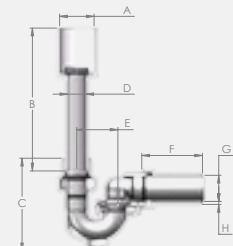

#### SINK TRAP DIMENSIONS:

A: 2.90"      E: 3.45"  
 B: 12.00"     F: 5.10"  
 C: 7.80"      G: 2.20"  
 D: 1.52"      H: 0.25"



## 1-1/4" P-TRAPS WITHOUT CLEANOUT

### SPECIFICATIONS

Dearborn Brass 1-1/4" Brass Tubular P-Trap without Cleanout are designed for use in tubular drain applications. Available in 17, 20 or Budget Gauge Brass. Options include Brass Nuts, Deep Flange, Longer Wall Tube and Ground Joint.

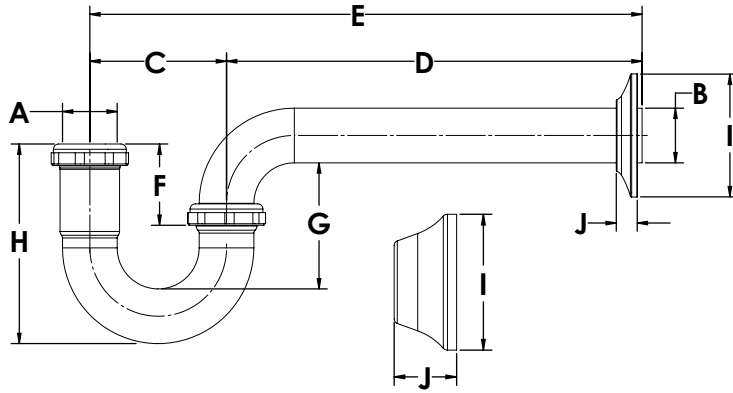

Option: Deep Flange



### APPROVALS & LISTINGS

cUPC (17 Ga. items)

### FEATURES & MATERIALS

Finish: Chrome Plated

#### 1-1/4" P-Trap Without Cleanout:

- (1) Metal Flange
- (1) Quarter Bend
- (1) J-Bend
- (2) Rubber Washers
- (2) Nuts
- (1) Reducing Washer

PRODUCT NO.	DESCRIPTION	CTN. QTY.	SIZE A	SIZE B	SIZE C	SIZE D	SIZE E	SIZE F	SIZE G	SIZE H	SIZE I	SIZE J	GAUGE
2700-1	P-Trap - Budget Ga.	25	1.25	1.25	3.10	7.50	10.60	1.80	3.30	4.30	2.80	0.40	Budget
2700A-1	P-Trap - Budget Ga.	25	1.25	1.25	3.10	9.50	12.60	1.80	3.30	4.30	2.80	0.40	Budget
2700DF-1	P-Trap - Budget Ga. w/ Deep Flange	25	1.25	1.25	3.10	7.50	10.60	1.80	3.30	4.30	3.00	1.40	Budget
700-1	P-Trap - 20 Ga.	25	1.25	1.25	3.10	7.50	10.60	1.80	3.30	4.30	2.80	0.40	20
700A-1	P-Trap - 20 Ga.	25	1.25	1.25	3.10	10.0	13.10	1.80	3.30	4.30	2.80	0.40	20
700BN-1	P-Trap - 20 Ga. w/ Brass Nuts	25	1.25	1.25	3.10	7.50	10.60	1.80	3.30	4.30	2.80	0.40	20
700DF-1	P-Trap - 20 Ga. w/ Deep Flange	25	1.25	1.25	3.10	7.50	10.60	1.80	3.30	4.30	3.00	1.40	20
700DFBN-1	P-Trap - 20 Ga. w/ Deep Flange & Brass Nuts	25	1.25	1.25	3.10	7.50	10.60	1.80	3.30	4.30	3.00	1.40	20
701-1	P-Trap - 17 Ga.	25	1.25	1.25	3.10	7.50	10.60	1.80	3.30	4.30	2.80	0.40	17
701BN-1	P-Trap - 17 Ga. w/ Brass Nuts	25	1.25	1.25	3.10	7.50	10.60	1.80	3.30	4.30	2.80	0.40	17
701DF-1	P-Trap - 17 Ga. w/ Deep Flange	25	1.25	1.25	3.10	7.50	10.60	1.80	3.30	4.30	3.00	1.40	17
701DFBN-1	P-Trap - 17 Ga. w/ Deep Flange & Brass Nuts	25	1.25	1.25	3.10	7.50	10.60	1.80	3.30	4.30	3.00	1.40	17
701A-1	P-Trap - 17 Ga.	25	1.25	1.25	3.10	10.0	13.10	1.80	3.30	4.30	2.80	0.40	17
701ADF-1	P-Trap - 17 Ga. w/ Deep Flange	25	1.25	1.25	3.10	10.0	13.10	1.80	3.30	4.30	3.00	1.40	17



## 1-1/2" P-TRAPS WITH CLEANOUT

### SPECIFICATIONS

Dearborn Brass 1-1/2" Brass Tubular P-Trap without Cleanout are designed for use in tubular drain applications. Available in 17, 20 or Budget Gauge Brass. Options include Brass Nuts, Deep Flange, Longer Wall Tube, Ground Joint and Unfinished Brass.

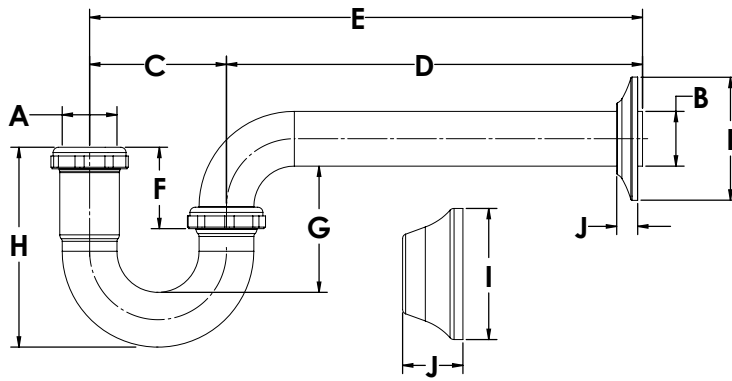

Option: Deep Flange



### APPROVALS & LISTINGS

cUPC

### FEATURES & MATERIALS

Finish: Chrome

#### 1-1/2" P-Trap Without Cleanout:

- (1) Metal Flange
- (1) Quarter Bend
- (1) J-Bend
- (2) Rubber Washers
- (2) Nuts
- (1) Reducing Washer

PRODUCT NO.	DESCRIPTION	CTN. QTY.	SIZE A	SIZE B	SIZE C	SIZE D	SIZE E	SIZE F	SIZE G	SIZE H	SIZE I	SIZE J	GAUGE
2702-1	P-Trap - Budget Ga.	25	1.50	1.50	3.10	8.125	11.225	1.80	3.30	4.30	2.80	0.40	Budget
2702DF-1	P-Trap - Budget Ga. w/ Deep Flange	25	1.50	1.50	3.10	8.125	11.225	1.80	3.30	4.30	3.00	1.40	Budget
702-1	P-Trap - 20 Ga.	25	1.50	1.50	3.10	8.125	11.225	1.80	3.30	4.30	2.80	0.40	20
702BN-1	P-Trap - 20 Ga. w/ Brass Nuts	25	1.50	1.50	3.10	8.125	11.225	1.80	3.30	4.30	2.80	0.40	20
702DF-1	P-Trap - 20 Ga. w/ Deep Flange	25	1.50	1.50	3.10	8.125	11.225	1.80	3.30	4.30	3.00	1.40	20
702DFBN-1	P-Trap - 20 Ga. w/ Deep Flange & Brass Nuts	25	1.50	1.50	3.10	8.125	11.225	1.80	3.30	4.30	3.00	1.40	20
702A-1	P-Trap - 20 Ga.	25	1.50	1.50	3.10	11.125	14.225	1.80	3.30	4.30	2.80	0.40	20
704-1	P-Trap - 17 Ga.	25	1.50	1.50	3.10	8.125	11.225	1.80	3.30	4.30	2.80	0.40	17
704BN-1	P-Trap - 17 Ga. w/ Brass Nuts	25	1.50	1.50	3.10	8.125	11.225	1.80	3.30	4.30	2.80	0.40	17
704DF-1	P-Trap - 17 Ga. w/ Deep Flange	25	1.50	1.50	3.10	8.125	11.225	1.80	3.30	4.30	3.00	1.40	17
704DFBN-1	P-Trap - 17 Ga. w/ Deep Flange & Brass Nuts	25	1.50	1.50	3.10	8.125	11.225	1.80	3.30	4.30	3.00	1.40	17
704A-1	P-Trap - 17 Ga.	25	1.50	1.50	3.10	11.125	14.225	1.80	3.30	4.30	2.80	0.40	17
704G-1	P-Trap - 17 Ga. w/ Ground Joint	25	1.50	1.50	3.10	8.125	11.225	1.80	3.30	4.30	2.80	0.40	17
704GBN-1	P-Trap - 17 Ga. w/ Ground Joint & Brass Nuts	25	1.50	1.50	3.10	8.125	11.225	1.80	3.30	4.30	2.80	0.40	17
704GBN-3	P-Trap - 17 Ga. w/ Ground Joint & Brass Nuts, Unfinished	25	1.50	1.50	3.10	8.125	11.225	1.80	3.30	4.30	2.80	0.40	17
704GD-FBN-1	P-Trap - 17 Ga. w/ Ground Joint, Deep Flange & Brass Nuts	25	1.50	1.50	3.10	8.125	11.225	1.80	3.30	4.30	3.00	1.40	17
704GBNA-1	P-Trap - 17 GA. w/ Ground Joint & Brass Nuts	10	1.50	1.50	3.10	15.00	18.10	1.80	3.30	4.30	2.80	0.40	17
704GBNA-3	P-Trap - 17 Ga. w/ Ground Joint & Brass Nuts, Unfinished	10	1.50	1.50	3.10	15.00	18.10	1.80	3.30	4.30	2.80	0.40	17





## 1-1/4" P-TRAPS WITH CLEANOUT

### SPECIFICATIONS

Dearborn Brass 1-1/4" Brass Tubular P-Trap with Cleanout are designed for use in tubular drain applications. Available in 17 or 20 Budget Gauge Brass. Options include Brass Nuts, Deep Flange, and Extended Wall Tube.

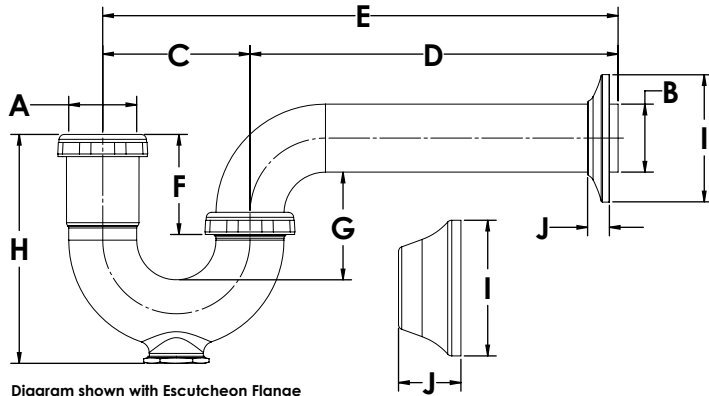

Diagram shown with Escutcheon Flange

Option: Deep Flange



### APPROVALS & LISTINGS

cUPC (17 Ga. items)

### FEATURES & MATERIALS

Finish: Chrome

#### 1-1/4" P-Trap With Cleanout:

- (1) Metal Flange
- (1) Quarter Bend
- (1) J-Bend w/ Cleanout Plug and Fiber Cleanout Washer
- (2) Rubber Washers
- (2) Nuts

PRODUCT NO.	DESCRIPTION	CTN. QTY.	SIZE A	SIZE B	SIZE C	SIZE D	SIZE E	SIZE F	SIZE G	SIZE H	SIZE I	SIZE J	GAUGE
706-1	P-Trap w/ Cleanout - 20 Ga.	10	1.25	1.25	3.10	7.50	10.60	2.60	3.10	5.00	2.81	0.48	20
707-1	P-Trap w/ Cleanout - 17 Ga.	10	1.25	1.25	3.10	7.50	10.60	2.60	3.10	5.00	2.81	0.48	17
707DF-1	P-Trap w/ Cleanout - 17 Ga. w/ Deep Flange	10	1.25	1.25	3.10	7.50	10.60	2.60	3.10	5.00	2.99	1.38	17
707A-1	P-Trap w/ Cleanout - 17 Ga.	10	1.25	1.25	3.10	10.00	13.10	2.60	3.10	5.00	2.81	0.48	17
707BN-1	P-Trap w/ Cleanout - 17 Ga. w/ Brass Nuts	10	1.25	1.25	3.10	7.50	10.60	2.60	3.10	5.00	2.81	0.48	17
707C-1	P-Trap w/ Cleanout - 17 Ga.	10	1.25	1.25	3.10	15.00	18.10	2.60	3.10	5.00	2.81	0.48	17



## 1-1/2" P-TRAPS WITHOUT CLEANOUT

### SPECIFICATIONS

Dearborn Brass 1-1/2" Brass Tubular P-Trap with Cleanout are designed for use in tubular drain applications. Available in 17 or 20 Gauge Brass. Options include Brass Nuts, Deep Flange, Unfinished Brass, Ground Joint and Extended Wall Tube.

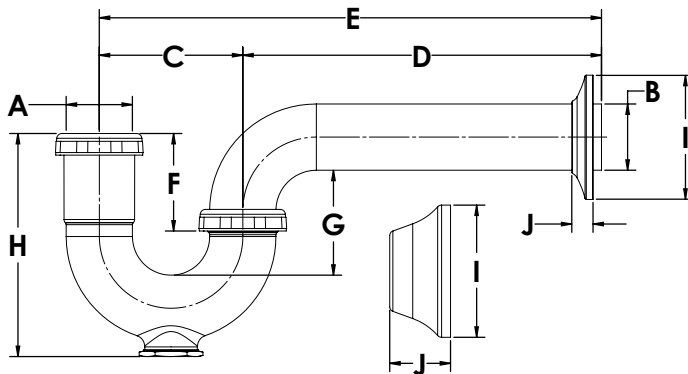

Diagram shown with Escutcheon Flange

Option: Deep Flange



### APPROVALS & LISTINGS

cUPC (17 Ga. items)

### FEATURES & MATERIALS

Finish: Chrome

#### 1-1/2" P-Trap With Cleanout:

- (1) Metal Flange
- (1) Quarter Bend
- (1) J-Bend w/ Cleanout Plug and Fiber Cleanout Washer
- (2) Washers
- (2) Nuts

PRODUCT NO.	DESCRIPTION	CTN. QTY.	SIZE A	SIZE B	SIZE C	SIZE D	SIZE E	SIZE F	SIZE G	SIZE H	SIZE I	SIZE J	GAUGE
708-1	P-Trap w/ Cleanout - 20 Ga.	10	1.50	1.50	3.10	8.125	11.225	2.60	3.10	5.00	2.81	0.48	20
710-1	P-Trap w/ Cleanout - 17 Ga.	10	1.50	1.50	3.10	8.125	11.225	2.60	3.10	5.00	2.81	0.48	17
710BN-1	P-Trap w/ Cleanout - 17 Ga. w/ Brass Nuts	10	1.50	1.50	3.10	8.125	11.225	2.60	3.10	5.00	2.81	0.48	17
710DF-1	P-Trap w/ Cleanout - 17 Ga. w/ Deep Flange	10	1.50	1.50	3.10	8.125	11.225	2.60	3.10	5.00	2.99	1.38	17
710GBN-1	P-Trap w/ Cleanout - 17 Ga. w/ Ground Joint & Brass Nuts	10	1.50	1.50	3.10	8.125	11.225	2.60	3.10	5.00	2.81	0.48	17
710GD-FBN-1	P-Trap w/ Cleanout - 17 Ga. w/ Ground Joint, Deep Flange & Brass Nuts	10	1.50	1.50	3.10	8.125	11.225	2.60	3.10	5.00	2.99	1.38	17



## 1-1/4" REPAIR TRAPS

### SPECIFICATIONS

Dearborn Brass 1-1/4" Brass Tubular Repair Traps are designed for use in tubular drain applications.

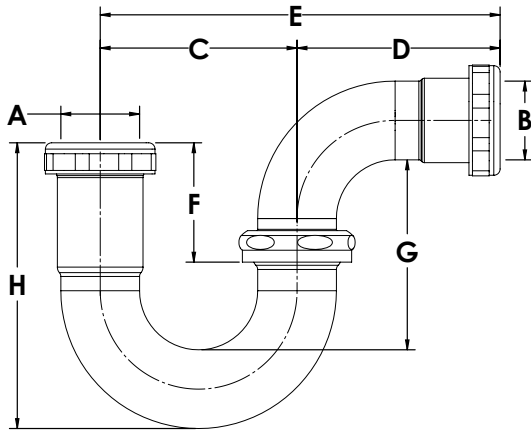

### FEATURES & MATERIALS

**Finish:** Chrome

**Material:** 20 Gauge Brass

#### Repair Trap:

- (1) J-Bend
- (1) Repair Outlet Bend with Brass Nut
- (3) Rubber Washers
- (2) Zinc Nuts

PRODUCT NO.	DESCRIPTION	CTN. QTY.	SIZE A	SIZE B	SIZE C	SIZE D	SIZE E	SIZE F	SIZE G	SIZE H	GAUGE
700R-1	Repair Trap - 20 Ga.	10	1.25	1.25	3.12	3.13	6.25	1.80	3.10	4.30	20



## 1-1/2" REPAIR TRAPS

### SPECIFICATIONS

Dearborn Brass 1-1/2" Brass Tubular Repair Traps are designed for use in tubular drain applications.

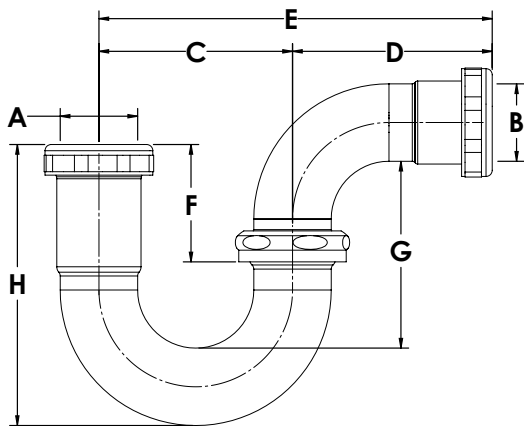

### FEATURES & MATERIALS

**Finish:** Chrome Plated

**Material:** 20 Gauge Brass

#### Repair Trap:

- (1) J-Bend
- (1) Repair Outlet Bend with Brass Nut
- (3) Rubber Washers
- (2) Zinc Nuts
- (1) Reducing Washer

PRODUCT NO.	DESCRIPTION	CTN. QTY.	SIZE A	SIZE B	SIZE C	SIZE D	SIZE E	SIZE F	SIZE G	SIZE H	GAUGE
702R-1	Repair Trap - 20 Ga.	10	1.50	1.50	3.12	3.13	6.25	1.80	3.10	4.30	20



## L.A. CODE TRAP

### SPECIFICATIONS

L.A. Code trap is designed for use in tubular drain applications.

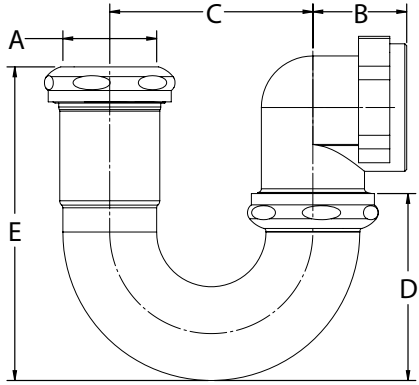

### APPROVALS & LISTINGS

cUPC

### FEATURES & MATERIALS

**Finish:** Chrome Plated or Unfinished

**Material:** 17 Gauge Brass

#### L.A. Code Trap:

- (1) Brass Nut(s)
- (1) Brass 90 Degree Elbow
- (1) Rubber Gasket
- (2) Rubber Washers
- (1) Reducing Washer

PRODUCT NO.	DESCRIPTION	CTN. QTY.	SIZE A	SIZE B	SIZE C	SIZE D	SIZE E	GAUGE
750-1	Repair Trap - 17 Ga. w/ Reducing Poly Washer	10	1.50	1.50	3.25	3.00	5.00	17
750-3	Repair Trap - 17 Ga. w/ Reducing Poly Washer, Unfinished	10	1.50	1.50	3.25	3.00	5.00	17



## WASHINGTON CODE TRAP WITHOUT CLEANOUT

### SPECIFICATIONS

Dearborn Brass 1-1/2" x 1-1/4" Washington Code Sink Traps is designed for use in tubular drain applications.

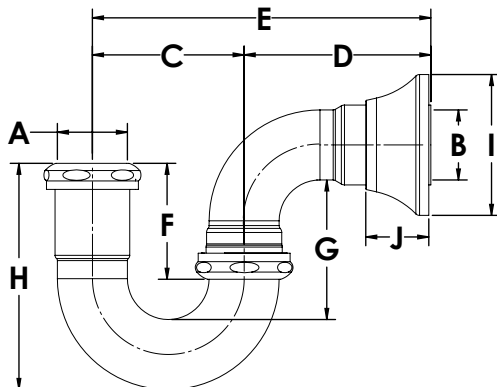

### APPROVALS & LISTINGS

cUPC

### FEATURES & MATERIALS

**Finish:** Chrome

**Material:** 17 Gauge Brass

#### 1-1/2" x 1-1/4" Sink Trap:

- (1) Deep Metal Flange
- (1) Outlet Bend
- (1) Sink J-Bend with Ground Joint Flange
- (1) Brass Nut
- (1) 1-1/2" x 1-1/4" Polyethylene Reducing Washer
- (1) 1-1/2" x 1-1/4" Rubber Washer

PRODUCT NO.	SIZE	DESCRIPTION	CTN. QTY.	SIZE A	SIZE B	SIZE C	SIZE D	SIZE E	SIZE F	SIZE G	SIZE H	SIZE I	SIZE J	GAUGE
743GD-FBN-1	1-1/2" x 1-1/4"	Wash Code P-Trap w/ Deep Flange & Brass Nuts	10	1.50	1.50	3.25	4.00	7.25	2.50	3.00	5.00	3.00	1.35	17



## WASHINGTON CODE TRAPS WITH CLEANOUT

### SPECIFICATIONS

Dearborn Brass 1-1/2" x 1-1/4" Washington Code Sink Traps is designed for use in tubular drain applications.

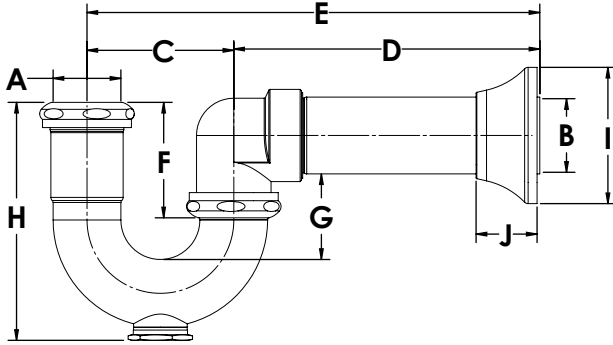

### APPROVALS & LISTINGS

cUPC

### FEATURES & MATERIALS

**Finish:** Chrome Plated

**Material:** 17 Gauge Brass

#### 1-1/2" x 1-1/4" Sink Trap:

- (1) Deep Metal Flange
- (1) Outlet Bend
- (1) Sink J-Bend with Ground Joint Flange
- (1) Brass Nut
- (1) 1-1/2" x 1-1/4" Polyethylene Reducing Washer
- (1) 1-1/2" x 1-1/4" Rubber Washer

PRODUCT NO.	SIZE	DESCRIPTION	CTN. QTY.	SIZE A	SIZE B	SIZE C	SIZE D	SIZE E	SIZE F	SIZE G	SIZE H	SIZE I	SIZE J	GAUGE
747GD-FBN-1	1-1/2" x 1-1/4"	Wash Code P-Trap w/ Cleanout, Deep Flange & Brass Nuts	10	1.50	1.50	3.25	4.00	7.25	2.60	1.90	5.30	3.00	1.35	17
727DFBN-6-1	1-1/2" x 1-1/4"	Sink Trap w/ Cleanout & 6" (SWT) Extension, Deep Flange & Brass	10	1.50	1.50	3.25	6.70	10.0	2.60	1.90	5.30	3.00	1.35	17



## SINK TRAPS WITH EXTENSION COVER TUBE

### SPECIFICATIONS

Dearborn Brass Sink Traps with Extension Tube Covers are designed for use in tubular drain applications. Available options include ABS or PVC Adapter.

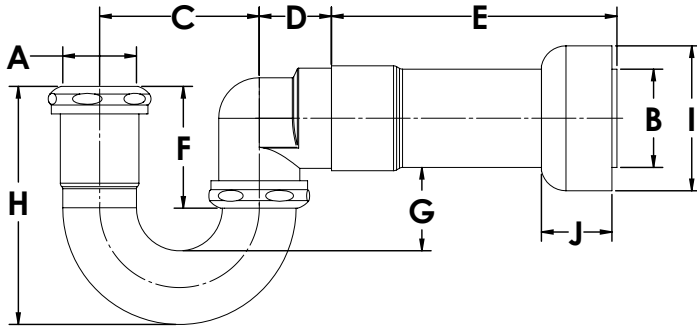

### APPROVALS & LISTINGS

cUPC

### FEATURES & MATERIALS

**Finish:** Chrome Plated

**Material:** 17 Gauge Brass

#### Sink Trap with Cover Tube:

- (1) Metal Flange
- (1) Sink J-Bend with Ground Joint Flange
- (1) Cover Tube
- (1) Schedule 40 Adapter (ABS or PVC)
- (1) Brass Nut
- (1) Rubber Washer
- (1) Polyethylene Reducing Washer

PRODUCT NO.	SIZE	DESCRIPTION	CTN. QTY.	SIZE A	SIZE B	SIZE C	SIZE D	SIZE E	SIZE F	SIZE G	SIZE H	SIZE I	SIZE J	GAUGE
730GPBN-6-1	1-1/2" x 1-1/4"	Sink Trap w/ Schedule 40 PVC Adapter, Ground Joint, Cover Tube & Escutcheon & Brass Nuts	5	1.50	2.00	3.25	1.40	6.00	2.60	1.80	5.00	2.95	1.44	17
730GABN-6-1	1-1/2" x 1-1/4"	Sink Trap w/ Schedule 40 ABS Adapter, Ground Joint, Cover Tube & Escutcheon & Brass Nuts	5	1.50	2.00	3.25	1.40	6.00	2.60	1.80	5.00	2.95	1.44	17



## SINK TRAPS WITH EXTENSION COVER TUBE & CLEANOUT

### SPECIFICATIONS

Dearborn Brass Sink Trap with Cleanout with Extension Tube Covers are designed for use in tubular drain applications. Cleanout plug provides convenient access to drain trap.

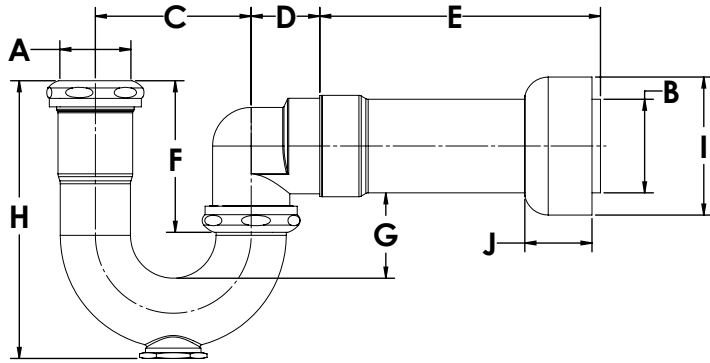

### APPROVALS & LISTINGS

cUPC

### FEATURES & MATERIALS

**Finish:** Chrome Plated

**Material:** 17 Gauge Brass

#### Sink Trap with Cleanout & Extension Cover Tube:

- (1) Metal Flange
- (1) Sink J-Bend with Ground Joint Flange
- (1) Chrome Plated Cover Tube
- (1) Schedule 40 PVC Adapter
- (1) Cleanout Plug
- (1) Fiber Cleanout Washer
- (1) Brass Nut
- (1) Rubber Washer
- (1) Polyethylene Reducing Washer

PRODUCT NO.	SIZE	DESCRIPTION	CTN. QTY.	SIZE A	SIZE B	SIZE C	SIZE D	SIZE E	SIZE F	SIZE G	SIZE H	SIZE I	SIZE J	GAUGE
732GPBN-6-1	1-1/2" x 1-1/4"	Sink Trap w/ Cleanout, Schedule 40 PVC Adapter, Ground Joint, Cover Tube & Escutcheon & Brass Nuts	5	1.50	2.00	3.25	1.40	6.00	2.60	1.80	5.90	2.95	1.44	17



## 1-1/4" SINK TRAPS WITHOUT CLEANOUT

### SPECIFICATIONS

Dearborn Brass 1-1/4" Brass Tubular Sink Trap with Slip Joint is designed for use in tubular drain applications.

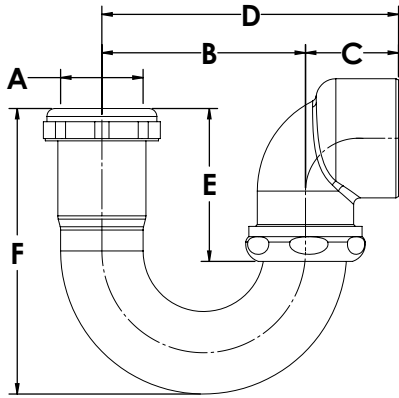

### FEATURES & MATERIALS

**Finish:** Chrome Plated

#### 1-1/4" Sink Trap without Cleanout:

- (1) Sink J-Bend
- (1) Sink Trap Elbow
- (1) Metal Flange
- (1) Brass Nut
- (1) Zinc Nut
- (2) Washers
- (1) Reducing Washer

PRODUCT NO.	DESCRIPTION	CTN. QTY.	SIZE A	SIZE B	SIZE C	SIZE D	SIZE E	SIZE F	GAUGE
736W-1	Sink Trap w/ Washer Joint NPT - 20 Ga.	10	1.25	3.10	1.60	4.70	2.20	4.30	20





## 1-1/2" SINK TRAPS WITHOUT CLEANOUT

### SPECIFICATIONS

Dearborn Brass 1-1/2" Brass Tubular Sink Trap with Slip Joint or Ground Joint is designed for use in tubular drain applications. Available in 17 or 20 Gauge Brass.

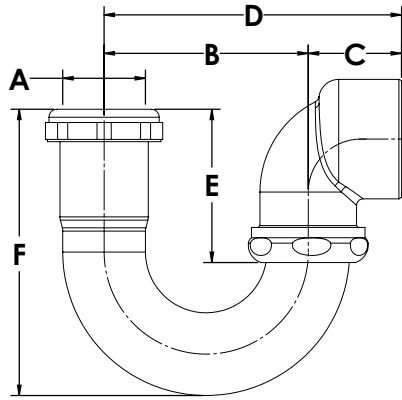

### APPROVALS & LISTINGS

cUPC (17 Ga. items)

### FEATURES & MATERIALS

**Finish:** Chrome Plated

#### 1-1/2" Sink Trap Without Cleanout:

- (1) Sink J-Bend
- (1) Sink Trap Elbow
- (1) Metal Flange
- (1) Brass Nut
- (1) Zinc Nut
- (1) Washer
- (1) Reducing Washer

PRODUCT NO.	DESCRIPTION	CTN. QTY.	SIZE A	SIZE B	SIZE C	SIZE D	SIZE E	SIZE F	GAUGE
738W-1	Sink Trap w/ Washer Joint NPT - 20 Ga	10	1.50	3.10	1.60	4.70	2.20	4.30	20
740W-1	Sink Trap w/ Washer Joint NPT - 17 Ga	10	1.50	3.10	1.60	4.70	2.20	4.30	17
740-1	Sink Trap w/ Ground Joint NPT - 17 Ga.	10	1.50	3.10	1.60	4.70	2.20	4.30	17



## 1-1/4" J-BENDS WITHOUT CLEANOUT

### SPECIFICATIONS

Dearborn Brass 1-1/4" Brass Tubular J-Bends are designed for use in tubular drain applications. Available in 17, 20 or Budget Gauge Brass.

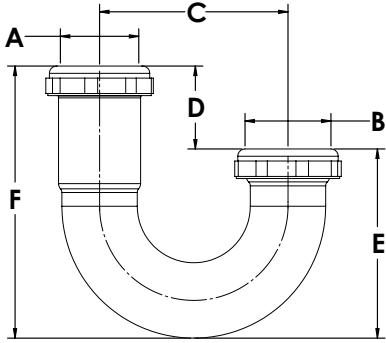

### APPROVALS & LISTINGS

cUPC (17 Ga. items)

### FEATURES & MATERIALS

**Finish:** Chrome Plated

#### J-Bend:

- (1) J-Bend
- (2) Zinc Nuts
- (2) Rubber Washers

PRODUCT NO.	DESCRIPTION	CTN. QTY.	SIZE A	SIZE B	SIZE C	SIZE D	SIZE E	SIZE F	GAUGE
2650-1	J-Bend - Budget Ga.	10	1.25	1.25	3.14	1.50	2.60	4.00	Budget
650-1	J-Bend - 20 Ga.	10	1.25	1.25	3.14	1.50	2.60	4.00	20
652-1	J-Bend - 17 Ga.	10	1.25	1.25	3.14	1.50	2.60	4.00	17



## 1-1/2" J-BENDS WITHOUT CLEANOUT

### SPECIFICATIONS

Dearborn Brass 1-1/2" Brass Tubular J-Bends are designed for use in tubular drain applications. Available in 17, 20 or Budget Gauge Brass.

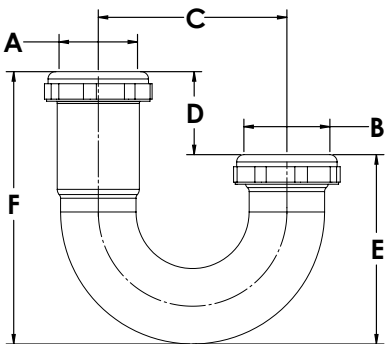

### APPROVALS & LISTINGS

cUPC (17 Ga. items)

### FEATURES & MATERIALS

**Finish:** Chrome Plated

#### J-Bend:

- (1) J-Bend
- (2) Zinc Nuts
- (2) Rubber Washers
- (1) Reducing Washer

PRODUCT NO.	DESCRIPTION	CTN. QTY.	SIZE A	SIZE B	SIZE C	SIZE D	SIZE E	SIZE F	GAUGE
2651-1	J-Bend - Budget Ga.	10	1.50	1.50	3.14	1.50	2.60	4.00	Budget
651-1	J-Bend - 20 Ga.	10	1.50	1.50	3.14	1.50	2.60	4.00	20
653-1	J-Bend - 17 Ga.	10	1.50	1.50	3.14	1.50	2.60	4.00	17



## 1-1/4" SINK J-BENDS WITHOUT CLEANOUT

### SPECIFICATIONS

Dearborn Brass 1-1/4" Brass Tubular Sink J-Bends are designed for use in tubular drain applications.

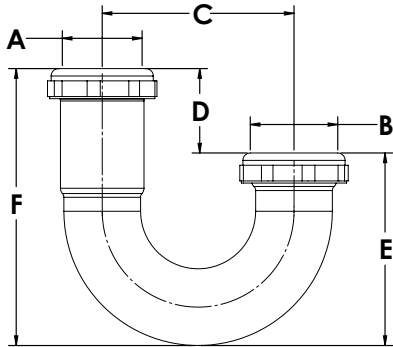

### FEATURES & MATERIALS

**Finish:** Chrome Plated

**Sink J-Bend:**

- (1) Sink J-Bend
- (1) Captured Nut
- (2) Rubber Washers

PRODUCT NO.	DESCRIPTION	CTN. QTY.	SIZE A	SIZE B	SIZE C	SIZE D	SIZE E	SIZE F	GAUGE
656W-1	Sink J-Bend w/ Washer Joint - 20 Ga.	10	1.25	1.25	3.14	1.50	2.60	4.00	20



## 1-1/2" J-BENDS WITHOUT CLEANOUT

### SPECIFICATIONS

Dearborn Brass 1-1/2" Brass Tubular Sink J-Bends are designed for use in tubular drain applications. Available in 17 or 20 Gauge Brass. Options include Brass Nut and Unfinished Brass.

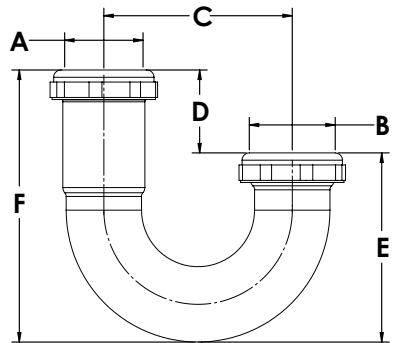

### APPROVALS & LISTINGS

cUPC (17 Ga. items)

### FEATURES & MATERIALS

**Finish:** Chrome Plated or Unfinished Brass

**Sink J-Bend:**

- (1) Sink J-Bend
- (1) Captured Nut
- (2) Rubber Washers

PRODUCT NO.	DESCRIPTION	CTN. QTY.	SIZE A	SIZE B	SIZE C	SIZE D	SIZE E	SIZE F	GAUGE
2654W-1	Sink J-Bend w/ Washer Joint - Budget Ga.	10	1.50	1.50	3.14	1.50	2.60	4.00	Budget
654W-1	Sink J-Bend w/ Washer Joint - 20 Ga.	10	1.50	1.50	3.14	1.50	2.60	4.00	20
655W-1	Sink J-Bend w/ Washer Joint - 17 Ga.	10	1.50	1.50	3.14	1.50	2.60	4.00	17
654-1	Sink J-Bend w/ Ground Joint - 20 Ga.	10	1.50	1.50	3.14	1.50	2.60	4.00	20
655BN-1	Sink J-Bend w/ Ground Joint - 17 Ga. w/ Brass Nuts	10	1.50	1.50	3.14	1.50	2.60	4.00	17
655BN-3	Sink J-Bend w/ Ground Joint - 17 Ga. w/ Brass Nuts, Unfinished	10	1.50	1.50	3.14	1.50	2.60	4.00	17



## 1-1/4" SEMI-CAST P-TRAPS WITH CLEANOUT

### SPECIFICATIONS

Dearborn Brass 1-1/4" Semi-Cast Brass P-Traps are designed for installation in commercial applications.

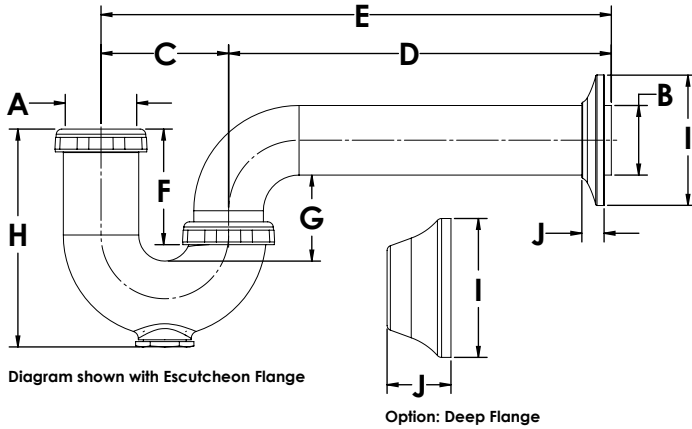

### APPROVALS & LISTINGS

cUPC

### FEATURES & MATERIALS

**Finish:** Chrome Plated

**Material:** 17 Gauge Brass

#### Semi-Cast P-Trap:

- (1) Cast J-Bend with Cleanout
- (1) Quarter Bend
- (1) Deep Metal Flange
- (1) Cleanout Plug
- (1) Fiber Cleanout Washer
- (2) Brass Nuts
- (1) 1-1/2" x 1-1/4" Reducing Washer
- (2) 1-1/2" Poly Washers
- (2) 1-1/2" Rubber Washers

PRODUCT NO.	DESCRIPTION	CTN. QTY.	SIZE A	SIZE B	SIZE C	SIZE D	SIZE E	SIZE F	SIZE G	SIZE H	SIZE I	SIZE J	GAUGE
507-1	Semi-Cast P-Trap w/ Cleanout 17 Ga. w/ Deep Flange & Brass Nuts	12	1.25	1.25	2.50	10.00	12.50	1.80	3.30	4.30	2.99	1.38	17
5507-1	Semi-Cast P-Trap w/ Cleanout 17 Ga. w/ Deep Flange & Brass Nuts, White Box	12	1.25	1.25	2.50	10.00	12.50	1.80	3.30	4.30	2.99	1.38	17
5507A-1	Semi-Cast P-Trap w/ Cleanout 17 Ga. w/ Deep Flange & Brass Nuts	12	1.25	1.25	2.50	13.00	15.50	1.80	3.30	4.30	2.99	1.38	17
505-1	Semi-Cast P-Trap w/ Cleanout 17 Ga. w/ Shallow Flange & Zinc Nuts	12	1.25	1.25	2.50	7.50	10.00	1.80	3.30	4.30	2.81	0.48	17



## 1-1/2" SEMI-CAST P-TRAPS WITH CLEANOUT

### SPECIFICATIONS

Dearborn Brass 1-1/2" Semi-Cast Brass P-Traps are designed for installation in commercial applications.

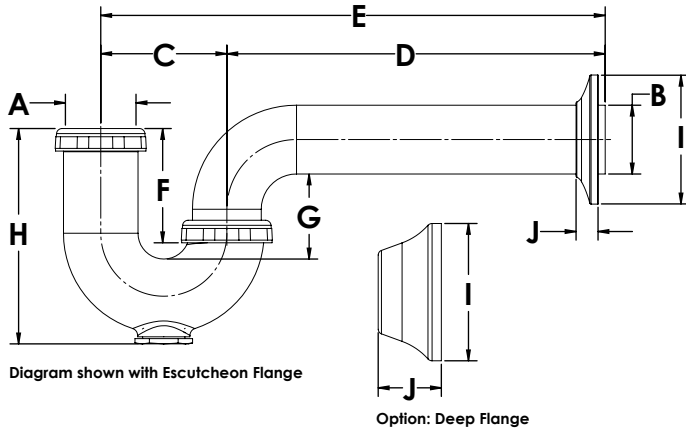

### APPROVALS & LISTINGS

cUPC

### FEATURES & MATERIALS

**Finish:** Chrome Plated

**Material:** 17 Gauge Brass

#### Semi-Cast P-Trap:

- (1) Cast J-Bend with Cleanout
- (1) 17 Ga. Quarter Bend
- (1) Deep Metal Flange
- (1) Cleanout Plug
- (1) Fiber Cleanout Washer
- (2) Brass Nuts
- (1) 1-1/2" x 1-1/4" Reducing Washer
- (2) 1-1/2" Poly Washers
- (2) 1-1/2" Rubber Washers

PRODUCT NO.	DESCRIPTION	CTN. QTY.	SIZE A	SIZE B	SIZE C	SIZE D	SIZE E	SIZE F	SIZE G	SIZE H	SIZE I	SIZE J	GAUGE
510-1	Semi-Cast P-Trap w/ Cleanout 17 Ga. w/ Deep Flange & Brass Nuts	12	1.50	1.50	2.50	10.00	12.50	1.80	3.30	4.30	2.99	1.38	17
5510-1	Semi-Cast P-Trap w/ Cleanout 17 Ga. w/ Deep Flange & Brass Nuts, White Box	12	1.50	1.50	2.50	10.00	12.50	1.80	3.30	4.30	2.99	1.38	17
5510A-1	Semi-Cast P-Trap w/ Cleanout 17 Ga. w/ Deep Flange & Brass Nuts	12	1.50	1.50	2.50	13.00	15.50	1.80	3.30	4.30	2.99	1.38	17
509-1	Semi-Cast P-Trap w/ Cleanout 17 Ga. w/ Shallow Flange & Zinc Nuts	12	1.50	1.50	2.50	7.50	10.00	1.80	3.30	4.30	2.81	0.48	17



## CENTER OUTLET WASTE WITH SLIP JOINT CONNECTION

### SPECIFICATIONS

Dearborn Brass 1-1/2" Brass Tubular Center Outlet Waste with Slip Joint Connection is designed for use in tubular drain applications. Available in 17, 20 or Budget Gauge Brass. Options include 16" or 21" lengths and Baffle Tee.

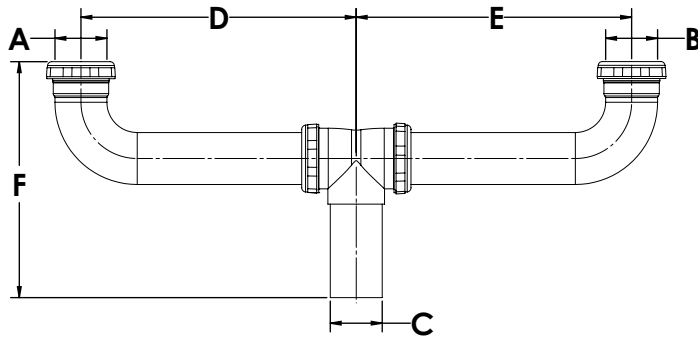

### APPROVALS & LISTINGS

cUPC (17 Ga. items)

### FEATURES & MATERIALS

**Finish:** Chrome Plated

#### Center Outlet Waste:

- (2) Waste Arms
- (1) Tailpiece
- (1) Twin Tee
- (2) Zinc Nuts
- (2) Rubber Washers

PRODUCT NO.	SIZE	DESCRIPTION	CTN. QTY.	SIZE A	SIZE B	SIZE C	SIZE D	SIZE E	SIZE F	GAUGE
2114A-1	1-1/2" x 16"	Center Outlet Waste, Slip Joint - Budget Ga.	5	1.50	1.50	1.50	8.00	8.00	6.00	Budget
114A-1	1-1/2" x 16"	Center Outlet Waste, Slip Joint - 20 Ga.	5	1.50	1.50	1.50	8.00	8.00	6.00	20
114B-1	1-1/2" x 21"	Center Outlet Waste, Slip Joint - 20 Ga.	5	1.50	1.50	1.50	10.50	10.50	6.00	20
117A-1	1-1/2" x 16"	Center Outlet Waste, Slip Joint - 17 Ga.	5	1.50	1.50	1.50	8.00	8.00	6.00	17
79A-1	1-1/2" x 16"	Center Outlet Waste, Slip Joint w/ Baffle Tee - 20 Ga.	5	1.50	1.50	1.50	8.00	8.00	6.00	20



## CENTER OUTLET WASTE WITH HI-LINE (FLANGED) CONNECTION

### SPECIFICATIONS

Dearborn Brass 1-1/2" Brass Tubular Center Outlet Waste with Hi-Line (Flanged) Connection is designed for use in tubular drain applications. Available in 17, 20 or Budget Gauge Brass. Options include 16" or 21" lengths and Baffle Tee.

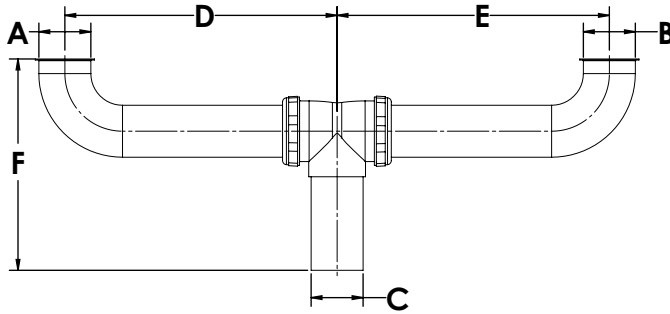

### APPROVALS & LISTINGS

cUPC (17 Ga. items)

### FEATURES & MATERIALS

**Finish:** Chrome Plated

#### Center Outlet Waste:

- (2) Waste Arms
- (1) Tailpiece
- (1) Twin Tee
- (2) Zinc Nuts
- (2) Rubber Washers

PRODUCT NO.	SIZE	DESCRIPTION	CTN. QTY.	SIZE A	SIZE B	SIZE C	SIZE D	SIZE E	SIZE F	GAUGE
2123A-1	1-1/2" x 16"	Center Outlet Waste, Hi-Line - Budget Ga.	5	1.50	1.50	1.50	8.00	8.00	5.80	Budget
123A-1	1-1/2" x 16"	Center Outlet Waste, Hi-Line - 20 Ga.	5	1.50	1.50	1.50	8.00	8.00	5.80	20
133A-1	1-1/2" x 16"	Center Outlet Waste, Hi-Line - 17 Ga.	5	1.50	1.50	1.50	8.00	8.00	5.80	17
83A-1	1-1/2" x 16"	Center Outlet Waste, Hi-Line w/ Baffle Tee - 20 Ga.	5	1.50	1.50	1.50	8.00	8.00	5.80	20



## 1-1/4" WALL TUBES

### SPECIFICATIONS

Dearborn Brass 1-1/4" Brass Tubular Wall Tubes are designed for use in tubular drain applications.

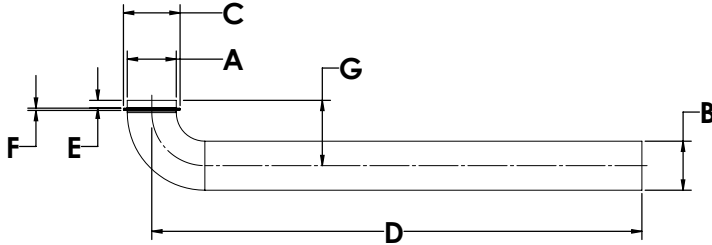

PRODUCT NO.	DESCRIPTION	CTN. QTY.	SIZE A	SIZE B	SIZE C	SIZE D	SIZE E	SIZE F	SIZE G	GAUGE
401A-17-1	Wall Tube 10" - 17 Ga.	10	1.25	1.25	1.50	10.00	0.24	0.10	2.10	17
401C-17-1	Wall Tube 21" - 17 Ga.	25	1.25	1.25	1.50	21.00	0.24	0.10	2.10	17
401D-17-1	Wall Tube 33" - 17 Ga.	25	1.25	1.25	1.50	33.00	0.24	0.10	2.10	17
401E-17-1	Wall Tube 45" - 17 Ga	10	1.25	1.25	1.50	45.00	0.24	0.10	2.10	17



### APPROVALS & LISTINGS

cUPC

### FEATURES & MATERIALS

**Finish:** Chrome Plated

**Wall Tube:**

(1) Quarter Bend Tube



## 1-1/2" WALL TUBES

### SPECIFICATIONS

Dearborn Brass 1-1/2" Brass Tubular Wall Tubes are designed for use in tubular drain applications. Available in 17 or Budget Gauge Brass.

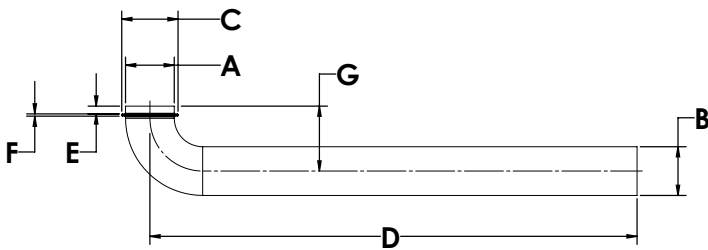

PRODUCT NO.	DESCRIPTION	CTN. QTY.	SIZE A	SIZE B	SIZE C	SIZE D	SIZE E	SIZE F	SIZE G	GAUGE
2402A-1	Wall Tube 11.25" - Budget Ga.	10	1.50	1.50	1.50	11.25	0.24	0.07	2.00	Budget
402-17-1	Wall Tube 8.25" - 17 Ga.	10	1.25	1.25	1.50	8.25	0.24	0.10	2.10	17
402A-17-1	Wall Tube 11.25" - 17 Ga.	10	1.25	1.25	1.50	11.25	0.24	0.10	2.10	17
402B-17-1	Wall Tube 15" - 17 Ga.	10	1.25	1.25	1.50	15.00	0.24	0.10	2.10	17
402C-17-1	Wall Tube 21" - 17 Ga.	25	1.25	1.25	1.50	21.00	0.24	0.10	2.10	17
402D-17-1	Wall Tube 33" - 17 Ga.	25	1.25	1.25	1.50	33.00	0.24	0.10	2.10	17
402E-17-1	Wall Tube 45" - 17 Ga.	20	1.25	1.25	1.50	45.00	0.24	0.10	2.10	17
402F-17-1	Wall Tube 57" - 17 Ga.	20	1.25	1.25	1.50	57.00	0.24	0.10	2.10	17



### APPROVALS & LISTINGS

cUPC

### FEATURES & MATERIALS

**Finish:** Chrome Plated

**Wall Tube:**

(1) Quarter Bend Tube





## WASHING MACHINE TRAP

### SPECIFICATIONS

Dearborn Brass 1-1/2" Brass Tubular Washing Machine Trap is designed for use in tubular drain applications.

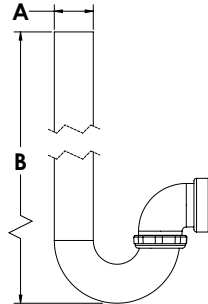

### FEATURES & MATERIALS

**Finish:** Chrome Plated

**Material:** 17 Gauge Brass

#### Washing Machine Trap:

- (1) Long J-Bend
- (1) Sink Trap
- (1) Zinc Nut
- (1) Rubber Washer

PRODUCT NO.	DESCRIPTION	CTN. QTY.	SIZE A	SIZE B	GAUGE
89-17-1	Washing Machine Trap NPT-17 Ga.	1	1.50	25.50	17



## END OUTLET WASTE WITH SLIP JOINT CONNCTION

### SPECIFICATIONS

Dearborn Brass 1-1/2" Brass Tubular Slip Joint End Outlet Waste is designed for use in tubular drain applications. Available in 17, 20 or Budget Gauge Brass. Options include Brass Nuts, Baffle Tee and 16" or 21".

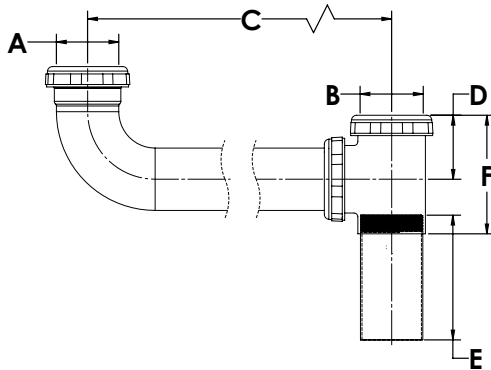

### APPROVALS & LISTINGS

cUPC (17 Ga. items)

### FEATURES & MATERIALS

**Finish:** Chrome Plated

#### End Outlet Waste:

- (1) Waste Arm
- (1) Tailpiece
- (1) Tee
- (3) Nuts
- (3) Washers

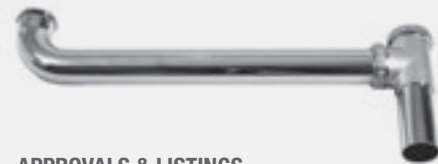

PRODUCT NO.	DESCRIPTION	CTN. QTY.	SIZE A	SIZE B	SIZE C	SIZE D	SIZE E	SIZE F	GAUGE
2108A-1	End Outlet Waste, Slip Joint - Budget Ga.	10	1.50	1.50	16.00	1.50	3.00	2.80	Budget
111A-1	End Outlet Waste, Slip Joint - 17 Ga.	10	1.50	1.50	16.00	1.50	3.00	2.80	17
111ABN-1	End Outlet Waste, Slip Joint - 17 Ga. w/ Brass Nuts	10	1.50	1.50	16.00	1.50	3.00	2.80	17
2178A-1	End Outlet Waste, Slip Joint w/ Baffle Tee - Budget Ga.	10	1.50	1.50	16.00	1.50	3.00	2.80	Budget
78A-1	End Outlet Waste, Slip Joint w/ Baffle Tee - 20 Ga.	10	1.50	1.50	16.00	1.50	3.00	2.80	20
78A-17BN-1	End Outlet Waste, Slip Joint w/ Baffle Tee & Brass Nuts - 17 Ga	10	1.50	1.50	16.00	1.50	3.00	2.80	17
78A-17-1	End Outlet Waste, Slip Joint w/ Baffle Tee - 17 Ga	10	1.50	1.50	16.00	1.50	3.00	2.80	17



## END OUTLET WASTE WITH HI-LINE (FLANGED) CONNECTION

### SPECIFICATIONS

Dearborn Brass 1-1/2" Brass Tubular Hi-Line End Outlet Waste is designed for use in tubular drain applications. Available 17, 20, Budget Gauge Brass. Options include 16" or 21" lengths made from Unfinished Brass, Brass Nuts and Baffle Tee.

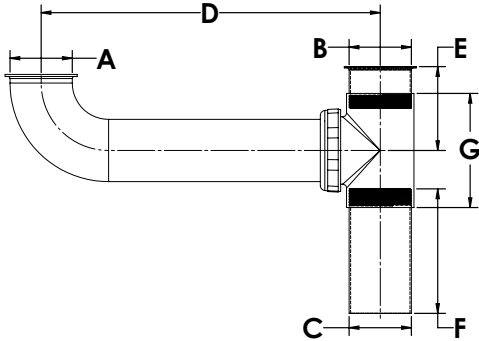

PRODUCT NO.	DESCRIPTION	CTN. QTY.	SIZE A	SIZE B	SIZE C	SIZE D	SIZE E	SIZE F	SIZE G	GAUGE
2121A-1	End Outlet Waste, Hi-Line - Budget Ga.	10	1.50	1.50	1.50	16.00	2.25	3.00	2.50	Budget
121A-1	End Outlet Waste, Hi-Line - 20 Ga.	10	1.50	1.50	1.50	16.00	2.25	3.00	2.50	20
121B-1	End Outlet Waste, Hi-Line - 20 Ga.	10	1.50	1.50	1.50	21.00	2.25	3.00	2.50	20
131A-1	End Outlet Waste, Hi-Line - 17 Ga.	10	1.50	1.50	1.50	16.00	2.25	3.00	2.50	17



### APPROVALS & LISTINGS

cUPC (17 Ga. items)

### FEATURES & MATERIALS

**Finish:** Chrome Plated or Unfinished brass

#### End Outlet Waste with Hi-Line:

- (1) Waste Arm
- (1) Tailpiece
- (1) Tee
- (1) Hi-Line Nipple
- (1) Nut
- (1) Rubber Washer



## 3 PART END OUTLET WASTE WITH SLIP JOINT CONNECTION

### SPECIFICATIONS

Dearborn Brass 1-1/2" Brass Tubular Three Part End Outlet Waste is designed for use in tubular drain applications.

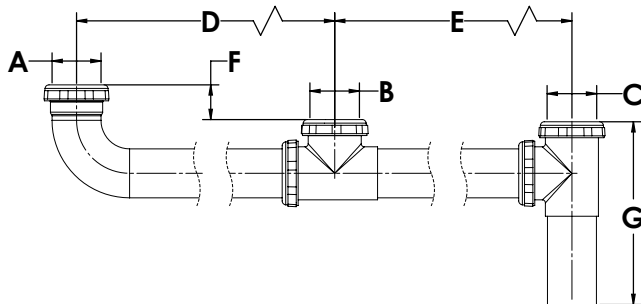

PRODUCT NO.	DESCRIPTION	CTN. QTY.	SIZE A	SIZE B	SIZE C	SIZE D	SIZE E	SIZE F	SIZE G	GAUGE
109-20-1	3 Part End Outlet Waste, Slip Joint - 20 Ga.	1	1.50	1.50	16.00	24.00	24.00	1.10	5.50	20



### FEATURES & MATERIALS

**Finish:** Chrome Plated

**Material:** 20 Gauge Brass

#### 3 Part End Outlet Waste:

- (1) Waste Arm
- (1) Tailpiece
- (2) Tees
- (5) Zinc Nuts
- (5) Rubber Washers



## 1-1/2" WASTE ARMS WITH SLIP JOINT

### SPECIFICATIONS

Dearborn Brass 1-1/2" Brass Tubular Waste Arm with Slip Joint Connection are designed for use in tubular drain applications. Available 17, 20, Budget Gauge Brass. Options include Brass Nuts and various lengths for use with Center or End Outlet Waste Assembly.

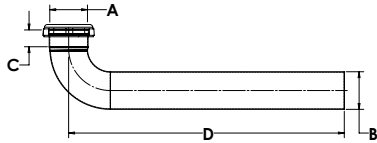

### APPROVALS & LISTINGS

cUPC (17 Ga. items)

### FEATURES & MATERIALS

**Finish:** Chrome Plated or Unfinished Brass

**Waste Arm with Slip Joint Connection:**

- (1) Waste Arm
- (1) Nut
- (1) Rubber Washer

PRODUCT NO.	DESCRIPTION	CTN. QTY.	SIZE A	SIZE B	SIZE C	SIZE D	GAUGE
2137-1	Waste Arm w/ Slip Joint For 16" Center Outlet - Budget Ga.	10	1.50	1.50	0.67	7.00	Budget
2137B-1	Waste Arm w/ Slip Joint For 24" Center Outlet - Budget Ga.	10	1.50	1.50	0.67	11.00	Budget
2137C-1	Waste Arm w/ Slip Joint For 16" Center Outlet - Budget Ga.	10	1.50	1.50	0.67	15.00	Budget
137-1	Waste Arm w/ Slip Joint For 16" Center Outlet - 20 Ga.	10	1.50	1.50	0.67	7.00	20
137C-1	Waste Arm w/ Slip Joint For 16" End Outlet - 20 Ga.	10	1.50	1.50	0.67	15.00	20
137CBN-3	Waste Arm w/ Slip Joint For 16" End Outlet - 20 Ga. w/ Brass Nuts, Unfinished	10	1.50	1.50	0.67	15.00	20
137D-1	Waste Arm w/ Slip Joint For 21" End Outlet - 20 Ga.	10	1.50	1.50	0.67	20.00	20
137E-1	Waste Arm w/ Slip Joint For 24" End Outlet - 20 Ga.	10	1.50	1.50	0.67	23.00	20
137EBN-3	Waste Arm w/ Slip Joint For 24" End Outlet - 20 Ga. w/ Brass Nuts, Unfinished	10	1.50	1.50	0.67	23.00	20
137-17BN-1	Waste Arm w/ Slip Joint For 16" Center Outlet - 17 Ga. w/ Brass Nuts	10	1.50	1.50	0.67	7.00	17
137C-17-1	Waste Arm w/ Slip Joint For 16" End Outlet - 17 Ga.	10	1.50	1.50	0.67	15.00	17
137C-17BN-3	Waste Arm w/ Slip Joint For 16" End Outlet - 17 Ga. w/ Brass Nuts, Unfinished	10	1.50	1.50	0.67	15.00	17
137E-17-1	Waste Arm w/ Slip Joint For 24" End Outlet - 17 Ga.	10	1.50	1.50	0.67	23.00	17



## 1-1/2" WASTE ARMS WITH HI-LINE (FLANGED) CONNECTION

### SPECIFICATIONS

Dearborn Brass 1-1/2" Brass Tubular Waste Arms with Hi-Line (Flanged) Connection are designed for use in tubular drain applications. Available in 17, 20 or Budget Gauge Brass. Options include various lengths for use with Center or End Outlet Waste Assembly.

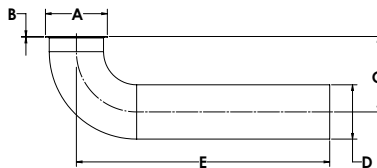

### APPROVALS & LISTINGS

cUPC (17 Ga. items)

### FEATURES & MATERIALS

**Finish:** Chrome Plated

**Waste Arm with High-Line (Flanged) Connection:**

- (1) Waste Arm

PRODUCT NO.	DESCRIPTION	CTN. QTY.	SIZE A	SIZE B	SIZE C	SIZE D	SIZE E	GAUGE
2138-1	Waste Arm w/ Hi-Line For 16" Center Outlet - Budget Ga.	10	1.50	0.05	1.50	1.50	7.00	Budget
2138C-1	Waste Arm w/ Hi-Line For 16" End Outlet - Budget Ga.	10	1.50	1.50	0.67	1.50	15.00	Budget
138-1	Waste Arm w/ Hi-Line For 16" Center Outlet - 20 Ga.	10	1.50	1.50	0.67	1.50	7.00	Budget
138C-1	Waste Arm w/ Hi-Line For 16" End Outlet - 20 Ga.	10	1.50	1.50	0.67	1.50	15.00	20
138D-1	Waste Arm w/ Hi-Line For 21" End Outlet - 20 Ga.	10	1.50	1.50	0.67	1.50	20.00	20
138B-17-1	Waste Arm w/ Hi-Line For 24" Center Outlet - 17 Ga.	10	1.50	1.50	0.67	1.50	11.00	17
138C-17-1	Waste Arm w/ Hi-Line For 16" End Outlet - 17 Ga.	10	1.5	1.50	0.67	1.50	15.00	17
138E-17-1	Waste Arm w/ Hi-Line For 24" End Outlet - 17 Ga.	10	1.50	1.50	0.67	1.50	23.00	17



## 1-1/4" EXTENSION TUBES WITH SOLDER JOINT

### SPECIFICATIONS

Dearborn Brass 1-1/4" Brass Tubular Extension Tubes with Solder Joints are designed for use in tubular drain applications. Available in 17 or Budget Gauge Brass. Options include various tube lengths.

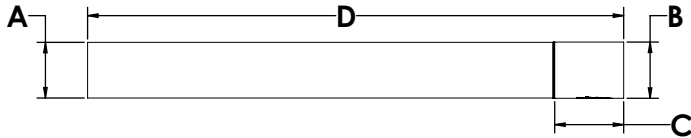

PRODUCT NO.	SIZE	DESCRIPTION	CTN. QTY.	SIZE A	SIZE B	SIZE C	SIZE D	GAUGE
787A-1	1-1/4" x 12"	Extension Tube w/ Solder Joint - Budget Ga.	10	1.25	1.25	1.60	12.00	Budget
787A-17-1	1-1/4" x 12"	Extension Tube w/ Solder Joint - 17 Ga.	10	1.25	1.25	1.60	12.00	17



### APPROVALS & LISTINGS

cUPC (17 Ga. items)

### FEATURES & MATERIALS

**Finish:** Chrome Plated

**Extension Tube with Solder Joint:**

(1) Extension Tube



## 1-1/2" EXTENSION TUBES WITH SOLDER JOINT

### SPECIFICATIONS

Dearborn Brass 1-1/2" Brass Tubular Extension Tubes with Solder Joints are designed for use in tubular drain applications. Available in 17 or Budget Gauge Brass. Options include various tube lengths.

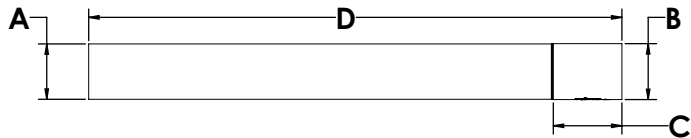

PRODUCT NO.	SIZE	DESCRIPTION	CTN. QTY.	SIZE A	SIZE B	SIZE C	SIZE D	GAUGE
788A-1	1-1/2" x 8"	Extension Tube w/ Solder Joint - Budget Ga.	10	1.50	1.50	1.60	8.00	Budget
789A-1	1-1/2" x 12"	Extension Tube w/ Solder Joint - Budget Ga.	10	1.50	1.50	1.60	12.00	Budget
789A-17-1	1-1/2" x 12"	Extension Tube w/ Solder Joint - 17 Ga.	10	1.50	1.50	1.60	12.00	17
789A-17-3	1-1/2" x 12"	Extension Tube w/ Solder Joint - 17 Ga., Unfinished	10	1.50	1.50	1.60	12.00	17



### APPROVALS & LISTINGS

cUPC (17 Ga. items)

### FEATURES & MATERIALS

**Finish:** Chrome Plated

**Extension Tube with Solder Joint:**

(1) Extension Tube



## 1-1/4" EXTENSION TUBES WITH THREADED JOINT

### SPECIFICATIONS

Dearborn Tubular Extension Tubes with Threaded Joint are manufactured with 17 or 20 gauge brass in various sizes for use in tubular drain applications.

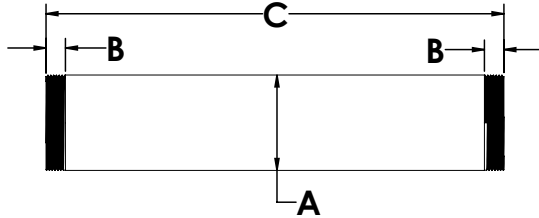

### APPROVALS & LISTINGS

cUPC (17 Ga. items)

### FEATURES & MATERIALS

**Finish:** Chrome Plated

**Extension Tube with Threaded Joint:**

(1) Extension Tube

PRODUCT NO.	SIZE	DESCRIPTION	CTN. QTY.	SIZE A	SIZE B	SIZE C	GAUGE
819-1	1-1/4" x 6"	Extension Tube, Threaded Both Ends - 20 Ga.	10	1.25	0.26	6.00	20
820A-1	1-1/4" x 8"	Extension Tube, Threaded Both Ends - 20 Ga.	10	1.25	0.26	8.00	20
822-1	1-1/4" x 12"	Extension Tube, Threaded Both Ends - 20 Ga.	10	1.25	0.26	12.00	20
822-3	1-1/4" x 12"	Extension Tube, Threaded Both Ends - 20 Ga., Unfinished	10	1.25	0.26	12.00	20
820C-1	1-1/4" x 8"	Extension Tube, Threaded Both Ends - 17 Ga.	10	1.25	0.26	8.00	17
822A-1	1-1/4" x 12"	Extension Tube, Threaded Both Ends - 17 Ga.	10	1.25	0.26	12.00	17



## 1-1/2" EXTENSION TUBES WITH THREADED JOINT BOTH ENDS

### SPECIFICATIONS

Dearborn Tubular Extension Tubes with Threaded Joint are manufactured with 17 or 20 gauge brass in various sizes for use in tubular drain applications.

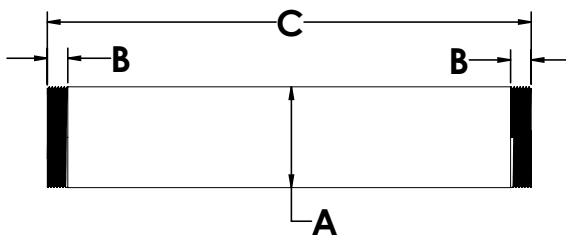

### APPROVALS & LISTINGS

cUPC (17 Ga. items)

### FEATURES & MATERIALS

**Finish:** Chrome Plated or Unfinished Brass

**Extension Tube with Threaded Joint Both Ends:**

(1) Threaded Both End Extension Tube

PRODUCT NO.	SIZE	DESCRIPTION	CTN. QTY.	SIZE A	SIZE B	SIZE C	GAUGE
828-1	1-1/2" x 6"	Extension Tube, Threaded Both Ends - 20 Ga.	10	1.50	0.26	6.00	20
825A-1	1-1/2" x 8"	Extension Tube, Threaded Both Ends - 20 Ga.	10	1.50	0.26	8.00	20
827-1	1-1/2" x 12"	Extension Tube, Threaded Both Ends - 20 Ga.	10	1.50	0.26	12.00	20
827-3	1-1/2" x 12"	Extension Tube, Threaded Both Ends - 20 Ga., Unfinished	10	1.50	0.26	12.00	20
827A-1	1-1/2" x 12"	Extension Tube, Threaded Both Ends - 17 Ga.	10	1.50	0.26	12.00	17
827A-3	1-1/2" x 12"	Extension Tube, Threaded Both Ends - 17 Ga., Unfinished	10	1.50	0.26	12.00	17



## 1-3/8" EXTENSION TUBES WITH THREADED JOINT

### SPECIFICATIONS

Dearborn Tubular Extension Tubes with Threaded Joint are manufactured with 17 or 20 gauge brass in various sizes for use in tubular drain applications.

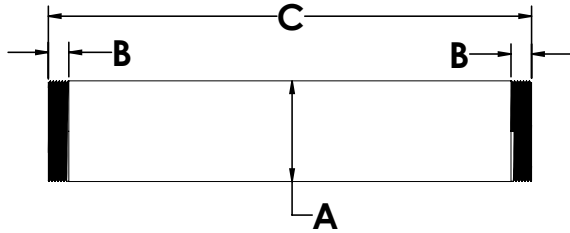

PRODUCT NO.	SIZE	DESCRIPTION	CTN. QTY.	SIZE A	SIZE B	SIZE C	GAUGE
824-1	1-3/8" x 12"	Extension Tube, Threaded Both Ends - 17 Ga.	10	1.38	0.31	12.00	17



### APPROVALS & LISTINGS

cUPC (17 Ga. items)

### FEATURES & MATERIALS

**Finish:** Chrome Plated

**Extension Tube with Threaded Joint:**

(1) Extension Tube



## 1-1/4" EXTENSION TUBES WITH SLIP JOINT

### SPECIFICATIONS

Dearborn Brass 1-1/4" Brass Tubular Extension Tubes with Slip Joint Connection are designed for use in tubular drain applications. Available in 17, 20 or Budget Gauge Brass. Options include Brass nuts, Unfinished Brass and various tube lengths.

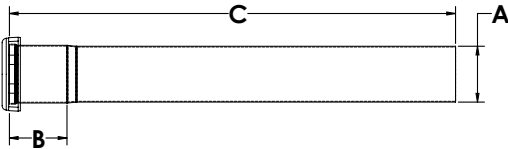

PRODUCT NO.	SIZE	DESCRIPTION	CTN. QTY.	SIZE A	SIZE B	SIZE C	GAUGE
790-1	1-1/4" x 6"	Extension Tube w/ Slip Joint - Budget Ga.	10	1.25	1.50	6.00	Budget
790A-1	1-1/4" x 8"	Extension Tube w/ Slip Joint - Budget Ga.	10	1.25	1.50	8.00	Budget
791A-1	1-1/4" x 12"	Extension Tube w/ Slip Joint - Budget Ga.	10	1.25	1.50	12.00	Budget
790-20-1	1-1/4" x 6"	Extension Tube w/ Slip Joint - 20 Ga.	10	1.25	1.50	6.00	20
790A-20-1	1-1/4" x 8"	Extension Tube w/ Slip Joint - 20 Ga.	10	1.25	1.50	8.00	20
791A-20-1	1-1/4" x 12"	Extension Tube w/ Slip Joint - 20 Ga.	10	1.25	1.50	12.00	20
791A-20BN-1	1-1/4" x 12"	Extension Tube w/ Slip Joint- 20 Ga. w/ Brass Nuts	10	1.25	1.50	12.00	20
790-17-1	1-1/4" x 6"	Extension Tube w/ Slip Joint - 17 Ga.	10	1.25	1.50	6.00	17
790-17BN-1	1-1/4" x 6"	Extension Tube w/ Slip Joint - 17 Ga. w/ Brass Nut	10	1.25	1.50	6.00	17
790A-17-1	1-1/4" x 8"	Extension Tube w/ Slip Joint - 17 Ga.	10	1.25	1.50	8.00	17
790A-17BN-1	1-1/4" x 8"	Extension Tube w/ Slip Joint - 17 Ga. w/ Brass Nut	10	1.25	1.50	8.00	17
791A-17-1	1-1/4" x 12"	Extension Tube w/ Slip Joint - 17 Ga.	10	1.25	1.50	12.00	17
791A-17BN-1	1-1/4" x 12"	Extension Tube w/ Slip Joint - 17 Ga. w/ Brass Nut	10	1.25	1.50	12.00	17
791B-17BN-1	1-1/4" x 24"	Extension Tube w/ Slip Joint - 17 Ga. w/ Brass Nut	10	1.25	1.50	24.00	17



### APPROVALS & LISTINGS

cUPC (17 Ga. items)

### FEATURES & MATERIALS

**Finish:** Chrome Plated or Unfinished Brass

**Extension Tube with Slip Joint Connection:**

(1) Extension Tube

(1) Nut

(1) Washer



## 1-1/2" EXTENSION TUBES WITH SLIP JOINT

### SPECIFICATIONS

Dearborn Brass 1-1/2" Brass Tubular Extension Tubes with Slip Joint Connection are designed for use in tubular drain applications. Available in 17, 20 or Budget Gauge Brass. Options include Brass nuts, Unfinished Brass and various tube lengths.

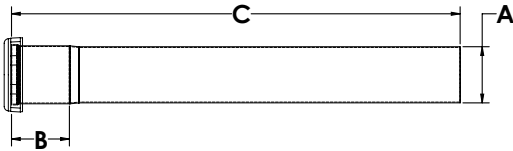

### APPROVALS & LISTINGS

cUPC (17 Ga. items)

### FEATURES & MATERIALS

**Finish:** Chrome Plated or Unfinished Brass

#### Extension Tube with Slip Joint Connection:

- (1) Extension Tube
- (1) Nut
- (1) Washer
- (1) Reducing Washer

PRODUCT NO.	SIZE	DESCRIPTION	CTN. QTY.	SIZE A	SIZE B	SIZE C	GAUGE
792-1	1-1/2" x 6"	Extension Tube w/ Slip Joint - Budget Ga.	10	1.50	1.60	6.00	Budget
792A-1	1-1/2" x 8"	Extension Tube w/ Slip Joint - Budget Ga.	10	1.50	1.60	8.00	Budget
793A-1	1-1/2" x 12"	Extension Tube w/ Slip Joint - Budget Ga.	10	1.50	1.60	12.00	Budget
792-20-1	1-1/2" x 6"	Extension Tube w/ Slip Joint - 20 Ga.	10	1.50	1.60	6.00	20
792A-20-1	1-1/2" x 8"	Extension Tube w/ Slip Joint - 20 Ga.	10	1.50	1.60	8.00	20
792A-20BN-1	1-1/2" x 8"	Extension Tube w/ Slip Joint - 20 Ga. w/ Brass Nut	10	1.50	1.60	8.00	20
793A-20-1	1-1/2" x 12"	Extension Tube w/ Slip Joint - 20 Ga.	10	1.50	1.60	12.00	20
793A-20BN-1	1-1/2" x 12"	Extension Tube w/ Slip Joint - 20 Ga. w/ Brass Nut	10	1.50	1.60	12.00	20
793A-20BN-3	1-1/2" x 12"	Extension Tube w/ Slip Joint - 20 Ga. w/ Brass Nut, Unfinished	10	1.50	1.60	12.00	20
792-17-1	1-1/2" x 6"	Extension Tube w/ Slip Joint - 17 Ga.	10	1.50	1.60	6.00	17
792A-17-1	1-1/2" x 8"	Extension Tube w/ Slip Joint - 17 Ga.	10	1.50	1.60	8.00	17
792A-17BN-1	1-1/2" x 8"	Extension Tube w/ Slip Joint - 17 Ga. w/ Brass Nut	10	1.50	1.60	8.00	17
793A-17-1	1-1/2" x 12"	Extension Tube w/ Slip Joint - 17 Ga.	10	1.50	1.60	12.00	17
793A-17BN-1	1-1/2" x 12"	Extension Tube w/ Slip Joint - 17 Ga. w/ Brass Nut	10	1.50	1.60	12.00	17
793A-17BN-3	1-1/2" x 12"	Extension Tube w/ Slip Joint - 17 Ga. w/ Brass Nut, Unfinished	10	1.50	1.60	12.00	17
794-17BN-1	1-1/2" x 24"	Extension Tube w/ Slip Joint - 17 Ga. w/ Brass Nut	10	1.50	1.60	24.00	17



## 1-1/2" DOUBLE FLANGED STRAINER TAILPIECES

### SPECIFICATIONS

Dearborn Brass Flanged Strainer Tailpieces are designed for use in tubular drain applications. Available in 17, 20 or Budget Gauge Brass. Options include Unfinished Brass and various tube lengths.

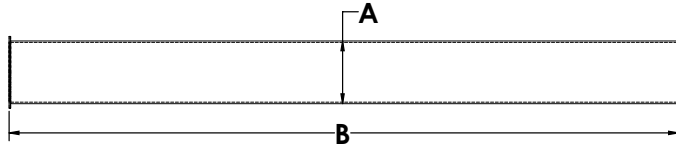

### APPROVALS & LISTINGS

cUPC (17 Ga. items)

### FEATURES & MATERIALS

**Finish:** Chrome Plated or Unfinished Brass

#### Sink Strainer Tailpieces:

(1) Double Flanged Strainer Tailpiece

PRODUCT NO.	SIZE	DESCRIPTION	CTN. QTY.	SIZE A	SIZE B	GAUGE
803ED-17-1	1-1/2" x 16"	Double Flanged Strainer Tailpiece -17 Ga.	10	1.50	16.00	17
803ED-17-3	1-1/2" x 16"	Double Flanged Strainer Tailpiece -17 Ga., Unfinished	10	1.50	16.00	17
803ED-20-1	1-1/2" X 16"	Double Flanged Strainer Tailpiece -20 Ga.	10	1.50	16.00	20
803ED-20-3	1-1/2" X 16"	Double Flanged Strainer Tailpiece -20 Ga., Unfinished	10	1.50	16.00	20
803BD-1	1-1/2" x 12"	Double Flanged Strainer Tailpiece - Budget Ga.	10	1.50	12.00	Budget
803ED-1	1-1/2" x 16"	Double Flanged Strainer Tailpiece - Budget Ga.	10	1.50	16.00	Budget



## 1-1/4" DOUBLE SLIP JOINT EXTENSION TUBES

### SPECIFICATIONS

Dearborn Brass 1-1/4" Brass Tubular Double Slip Joint Extension Tubes are designed for use in tubular drain applications. Available in 20 or Budget Gauge Brass. Options include 12" or 16" length and Brass Nuts.

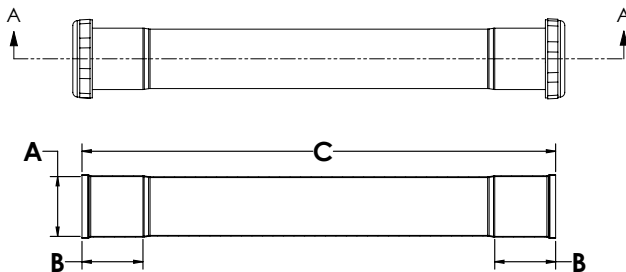

### FEATURES & MATERIALS

**Finish:** Chrome Plated

#### 1-1/4" Double Slip Joint Extension Tube:

- (1) Double Extension Tube
- (2) Nuts
- (2) Rubber Washers

PRODUCT NO.	SIZE	DESCRIPTION	CTN. QTY.	SIZE A	SIZE B	SIZE C	GAUGE
791B-1	1-1/4" x 12"	Double Slip Joint Extension Tube - Budget Ga.	5	1.25	1.58	12.00	Budget
791BD-1	1-1/4" x 16"	Double Slip Joint Extension Tube - Budget Ga.	5	1.25	1.58	16.00	Budget
791BD-20BN-1	1-1/4" x 16"	Double Slip Joint Extension Tube - 20 Ga. w/ Brass Nuts	5	1.25	1.58	16.00	20





## 1-1/2" DOUBLE SLIP JOINT EXTENSION TUBES

### SPECIFICATIONS

Dearborn Brass 1-1/2" Brass Tubular Double Slip Joint Extension Tubes are designed for use in tubular drain applications. Available in 20 or Budget Gauge Brass. Options include 12" or 16" length and Brass Nuts.

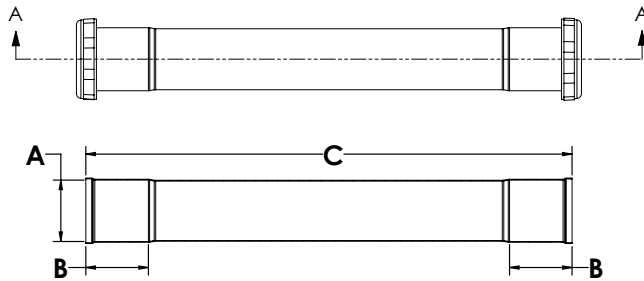

### FEATURES & MATERIALS

**Finish:** Chrome Plated

#### 1-1/2" Double Slip Joint Extension Tube:

- (1) Double Extension Tube
- (2) Nuts
- (2) Rubber Washers
- (2) Reducing Washers

PRODUCT NO.	SIZE	DESCRIPTION	CTN. QTY.	SIZE A	SIZE B	SIZE C	GAUGE
793B-1	1-1/2" x 12"	Double Slip Joint Extension Tube - Budget Ga.	5	1.50	1.58	12.00	Budget
793BD-1	1-1/2" x 16"	Double Slip Joint Extension Tube - Budget Ga.	5	1.50	1.58	16.00	Budget
793BD-20BN-1	1-1/2" x 16"	Double Slip Joint Extension Tube - 20 Ga. w/ Brass Nuts	5	1.50	1.58	16.00	20
793BD-20BN-3	1-1/2" x 16"	Double Slip Joint Extension Tube - 20 Ga. w/ Brass Nuts, Unfinished	5	1.50	1.58	16.00	20



## 1-1/2" X 1-1/4" FLANGED STRAINER TAILPIECES

### SPECIFICATIONS

Dearborn Brass Flanged Strainer Tailpieces are designed for use in tubular drain applications. Available in 17, 20 or Budget Gauge Brass. Options include various tube lengths.

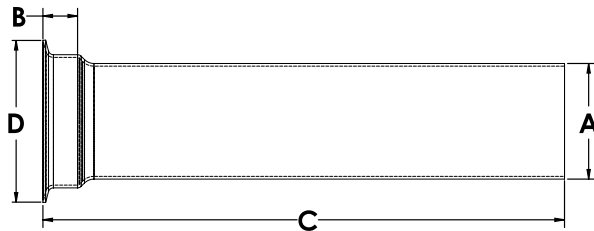

### FEATURES & MATERIALS

**Finish:** Chrome Plated

#### Sink Strainer Tailpieces:

- (1) Flanged Strainer Tailpiece

PRODUCT NO.	SIZE	DESCRIPTION	CTN. QTY.	SIZE A	SIZE B	SIZE C	SIZE D	GAUGE
795-1	1-1/2" x 1-1/4" x 6"	Flanged Strainer Tailpiece - 20 Ga.	10	1.25	0.32	6.00	1.76	20
796-1	1-1/2" x 1-1/4" x 8"	Flanged Strainer Tailpiece - 20 Ga.	10	1.25	0.32	8.00	1.76	20
798-1	1-1/2" x 1-1/4" x 12"	Flanged Strainer Tailpiece - 20 Ga.	10	1.25	0.32	12.00	1.76	20



## 1-1/2" FLANGED STRAINER TAILPIECES

### SPECIFICATIONS

Dearborn Brass Flanged Strainer Tailpieces are designed for use in tubular drain applications. Available in 17, 20 or Budget Gauge Brass. Options include Unfinished Brass and various tube lengths.

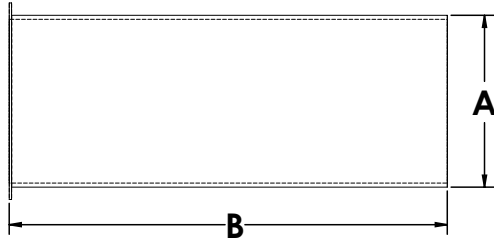

### APPROVALS & LISTINGS

cUPC (17 Ga. items)

### FEATURES & MATERIALS

**Finish:** Chrome Plated or Unfinished Brass

### Sink Strainer Tailpieces:

(1) Flanged Strainer Tailpiece

PRODUCT NO.	SIZE	DESCRIPTION	CTN. QTY.	SIZE A	SIZE B	GAUGE
799-1	1-1/2" x 4"	Flanged Strainer Tailpiece - Budget Ga.	10	1.50	4.00	Budget
799-3	1-1/2" x 4"	Flanged Strainer Tailpiece - Budget Ga., Unfinished	10	1.50	4.00	Budget
800-1	1-1/2" x 6"	Flanged Strainer Tailpiece - Budget Ga.	10	1.50	6.00	Budget
801-1	1-1/2" x 8"	Flanged Strainer Tailpiece - Budget Ga.	10	1.50	8.00	Budget
803-1	1-1/2" x 12"	Flanged Strainer Tailpiece - Budget Ga.	10	1.50	12.00	Budget
800-20-1	1-1/2" x 6"	Flanged Strainer Tailpiece - 20 Ga.	10	1.50	6.00	20
801-20-1	1-1/2" x 8"	Flanged Strainer Tailpiece - 20 Ga.	10	1.50	8.00	20
801-20-3	1-1/2" x 8"	Flanged Strainer Tailpiece - 20 Ga., Unfinished	10	1.50	8.00	20
803-20-1	1-1/2" x 12"	Flanged Strainer Tailpiece - 20 Ga.	10	1.50	12.00	20
803-20-3	1-1/2" x 12"	Flanged Strainer Tailpiece - 20 Ga., Unfinished	10	1.50	12.00	20
799-17-1	1-1/2" x 4"	Flanged Strainer Tailpiece -17 Ga.	10	1.50	4.00	17
799-17-3	1-1/2" x 4"	Flanged Strainer Tailpiece, 17 Ga., Unfinished	10	1.50	4.00	17
800-17-1	1-1/2" x 6"	Flanged Strainer Tailpiece -17 Ga.	10	1.50	6.00	17
800-17-3	1-1/2" x 6"	Flanged Strainer Tailpiece -17 Ga., Unfinished	10	1.50	6.00	17
801-17-1	1-1/2" x 8"	Flanged Strainer Tailpiece -17 Ga.	10	1.50	8.00	17
801-17-3	1-1/2" x 8"	Flanged Strainer Tailpiece -17 Ga., Unfinished	10	1.50	8.00	17
803-17-1	1-1/2" x 12"	Flanged Strainer Tailpiece -17 Ga.	10	1.50	12.00	17
803-17-3	1-1/2" x 12"	Flanged Strainer Tailpiece -17 Ga., Unfinished	10	1.50	12.00	17



## 1-1/2" BRANCH TAILPIECES WITH 1/2" NOMINAL SWEAT BRANCH

### SPECIFICATIONS

Dearborn Brass 1-1/2" Brass Tubular Branch Tailpieces with Nominal Sweat Branch are designed for use in tubular drain applications. Available in 17, 20 or Budget Gauge Brass. Options include Unfinished Brass, various lengths and Brass Nuts.

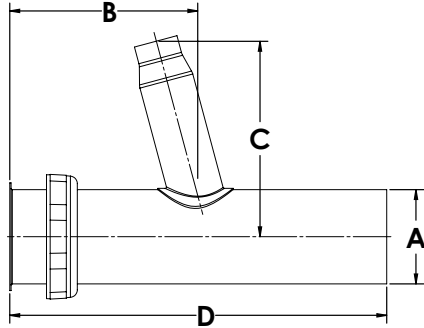

### APPROVALS & LISTINGS

cUPC (17 Ga. items)

### FEATURES & MATERIALS

**Finish:** Chrome Plated or Unfinished Brass

**Branch Tailpiece with Hose & Clamp Connection:**

(1) Branch Tailpiece

PRODUCT NO.	SIZE	DESCRIPTION	CTN. QTY.	SIZE A	SIZE B	SIZE C	SIZE D	GAUGE
812A-1	1-1/2" x 6"	Branch Tailpiece, 1/2" Nominal Sweat Branch, Budget Ga.	10	1.50	2.95	3.11	6.00	Budget
812B-1	1-1/2" x 8"	Branch Tailpiece, 1/2" Nominal Sweat Branch, Budget Ga.	10	1.50	2.95	3.11	8.00	Budget
812B-3	1-1/2" x 8"	Branch Tailpiece, 1/2" Nominal Sweat Branch, Budget Ga., Unfinished	10	1.50	2.00	3.11	8.00	Budget
812B-17BN-3	1-1/2" x 8"	Branch Tailpiece DC, 1/2" Nominal Sweat Branch, 17 Ga. w/ Brass Nut, Unfinished	10	1.50	2.00	3.11	8.00	17



## 1-1/2" BRANCH TAILPIECES WITH HOSE & CLAMP

### SPECIFICATIONS

Dearborn Brass 1-1/2" Brass Tubular Branch Tailpieces With Hose & Clamp are designed for use in tubular drain applications. Available in 17, 20 or Budget Gauge Brass. Options include various lengths and brass nuts.

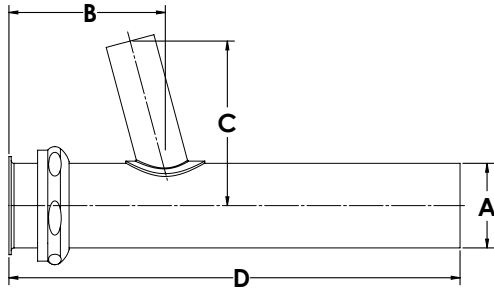

### APPROVALS & LISTINGS

cUPC (17 Ga. items)

### FEATURES & MATERIALS

**Finish:** Chrome Plated

#### Branch Tailpiece with Hose & Clamp Connection:

- (1) Branch Tailpiece
- (1) Captured Nut

PRODUCT NO.	SIZE	DESCRIPTION	CTN. QTY.	SIZE A	SIZE B	SIZE C	SIZE D	GAUGE
814A-1	1-1/2" x 6"	Branch Tailpiece, Hose & Clamp - Budget Ga.	10	1.50	2.00	2.92	6.00	Budget
814B-1	1-1/2" x 8"	Branch Tailpiece, Hose & Clamp - Budget Ga.	10	1.50	2.00	2.92	8.00	Budget
814BBN-1	1-1/2" x 8"	Branch Tailpiece, Hose & Clamp w/ Brass Nuts - 20 Ga.	10	1.50	2.00	2.92	8.00	20
814B-17-1	1-1/2" x 8"	Branch Tailpiece, Hose & Clamp - 17 Ga.	10	1.50	2.00	2.92	8.00	17



## 1-1/4" BRANCH TAILPIECES WITH HOSE & CLAMP, THREADED TOP

### SPECIFICATIONS

Dearborn Brass 1-1/2" Brass Tubular Branch Tailpieces With Hose & Clamp are designed for use in tubular drain applications.

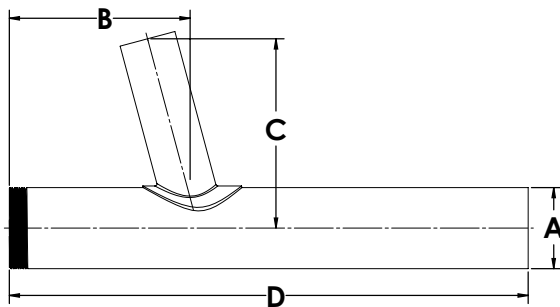

### FEATURES & MATERIALS

**Finish:** Chrome Plated

#### Branch Tailpiece with Hose & Clamp Connection:

- (1) Branch Tailpiece

PRODUCT NO.	SIZE	DESCRIPTION	CTN. QTY.	SIZE A	SIZE B	SIZE C	SIZE D	GAUGE
817TB-1	1-1/4" x 8"	Branch Tailpiece, Hose & Clamp, Threaded Top - 20 Ga., 7/8" Branch	10	1.25	2.00	2.87	8.00	20



## 1-1/2" BRANCH TAILPIECES WITH HOSE & CLAMP, THREADED UP

### SPECIFICATIONS

Dearborn Brass 1-1/2" Brass Tubular Branch Tailpieces With Hose & Clamp are designed for use in tubular drain applications.

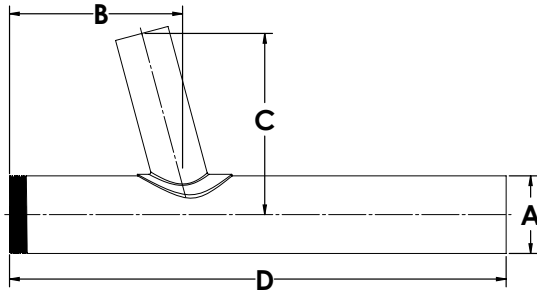

### FEATURES & MATERIALS

**Finish:** Chrome Plated or Unfinished Brass  
**1-1/2" Branch Tailpieces, Hose & Clamp, Threaded Up:**

- (1) Branch Tailpiece

PRODUCT NO.	SIZE	DESCRIPTION	CTN. QTY.	SIZE A	SIZE B	SIZE C	SIZE D	GAUGE
814TB-1	1-1/2" x 8"	Branch Tailpiece, Hose & Clamp, Threaded Top - 20 Ga.	10	1.50	2.00	2.92	8.00	20



## 1-1/4" BRANCH TAILPIECES WITH HOSE & CLAMP, SLIP JOINT TOP

### SPECIFICATIONS

Dearborn Brass 1-1/4" Brass Tubular Branch Tailpieces With Hose & Clamp are designed for use in tubular drain applications. Available in 17, 20 or Budget Gauge Brass. Options include Unfinished Brass and various lengths.

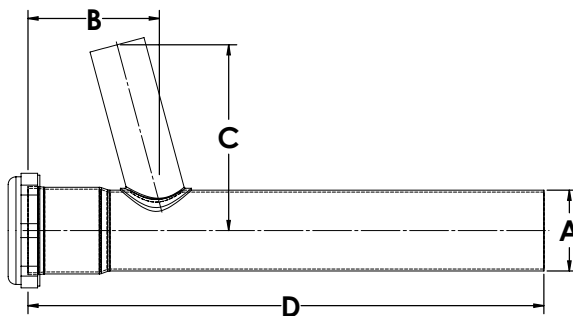

### FEATURES & MATERIALS

**Finish:** Chrome Plated or Unfinished Brass  
**1-1/4" Branch Tailpieces, Hose & Clamp, Slip Joint Top:**

- (1) Branch Tailpiece
- (1) Nut
- (1) Washer

PRODUCT NO.	SIZE	DESCRIPTION	CTN. QTY.	SIZE A	SIZE B	SIZE C	SIZE D	GAUGE
817ET-1	1-1/4" x 8"	Branch Tailpiece, Hose & Clamp, Slip Joint Top - 20 Ga., (Nut Down)	10	1.25	2.00	2.87	8.00	20
817ETBN-1	1-1/4" x 8"	Branch Tailpiece, Hose & Clamp, Slip Joint Top - 20 Ga. w/ Brass Nut (Nut Down)	10	1.25	2.00	2.87	8.00	20
817ETBN-3	1-1/4" x 8"	Branch Tailpiece, Hose & Clamp, Slip Joint Top - 20 Ga. w/ Brass Nut, Unfinished (Nut Down)	10	1.25	2.00	2.87	8.00	20



## 1-1/2" BRANCH TAILPIECES WITH HOSE & CLAMP, SLIP JOINT TOP

### SPECIFICATIONS

Dearborn Brass 1-1/2" Brass Tubular Branch Tailpieces With Hose & Clamp are designed for use in tubular drain applications. Available in 17, 20 or Budget Gauge Brass. Options include Unfinished Brass and various lengths.

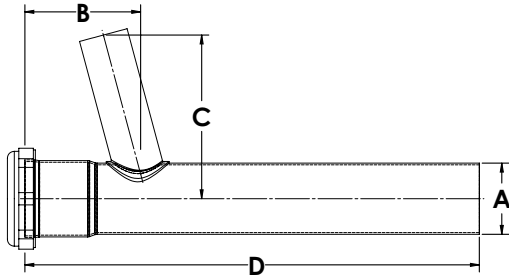

### APPROVALS & LISTINGS

cUPC (17 Ga. items)

### FEATURES & MATERIALS

**Finish:** Chrome Plated or Unfinished Brass

**1-1/2" Branch Tailpieces, Hose & Clamp,**

**Slip Joint Top:**

- (1) Branch Tailpiece
- (1) Nut
- (1) Washer
- (1) Reducing Washer

PRODUCT NO.	SIZE	DESCRIPTION	CTN. QTY.	SIZE A	SIZE B	SIZE C	SIZE D	GAUGE
814ET-1	1-1/2" x 8"	Branch Tailpiece, Hose & Clamp, Slip Joint Top - 20 Ga., 7/8" Branch (Nut Down)	10	1.50	2.00	3.13	8.00	20
814ETBN-1	1-1/2" x 8"	Branch Tailpiece, Hose & Clamp, Slip Joint Top, 20 Ga. w/ Brass Nut, 7/8" Branch (Nut Down)	10	1.50	2.00	2.92	8.00	20
814ETBN-3	1-1/2" x 8"	Branch Tailpiece, Hose & Clamp, Slip Joint Top - 20 Ga. w/ Brass Nut, 7/8" Branch (Nut Down), Unfinished	10	1.50	2.00	2.92	8.00	20
814ET-17-1	1-1/2" x 8"	Branch Tailpiece, Hose & Clamp, Slip Joint Top - 17 Ga., 7/8" Branch (Nut Down)	10	1.50	2.00	2.92	8.00	17



## BRANCH TAILPIECES, 3/4" HOSE OR 1/2" NOMINAL SWEAT

### SPECIFICATIONS

Dearborn Brass 1-1/2" Brass Tubular Branch Tailpieces with Hose & Clamp or Nominal Sweat Branch are designed for use in tubular drain applications.

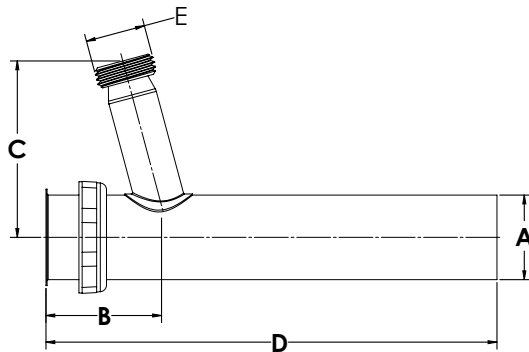

### FEATURES & MATERIALS

**Finish:** Chrome Plated

**Branch Tailpiece with Hose & Clamp Connection:**

- (1) Branch Tailpiece
- (1) Captured Nut

PRODUCT NO.	SIZE	DESCRIPTION	CTN. QTY.	SIZE A	SIZE B	SIZE C	SIZE D	SIZE E	GAUGE
813B-1	1-1/2" x 8"	Branch Tailpiece, 3/4" Hose or 1/2" Nominal Sweat, Budget Ga.	10	1.50	2.00	3.13	8.00	.75 - 11.5 NH	Budget



## BRANCH TAILPIECES, DISHWASHER TAILPIECE WITH BRASS NUT

### SPECIFICATIONS

Dearborn Brass 1-1/2" Dishwasher Tailpiece is designed for use with tubular drain applications.

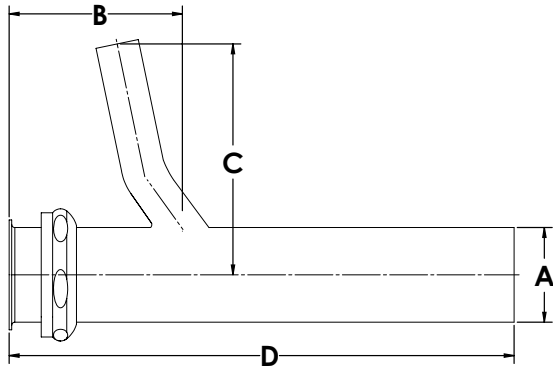

### FEATURES & MATERIALS

**Finish:** Unfinished Brass

**Branch Tailpiece with Hose & Clamp Connection:**

- (1) Branch Tailpiece
- (1) Captured Nut

PRODUCT NO.	SIZE	DESCRIPTION	CTN. QTY.	SIZE A	SIZE B	SIZE C	SIZE D	GAUGE
813B-3	1-1/2" x 12"	Dishwasher tailpiece with brass nut	10	1.50	2.00	4.10	12.00	22



## 1-1/4" DOUBLE SLIP JOINT CONNECTION

### SPECIFICATIONS

Dearborn Brass 1-1/4" Double Slip Joint Connectors are designed for use in tubular drain applications.

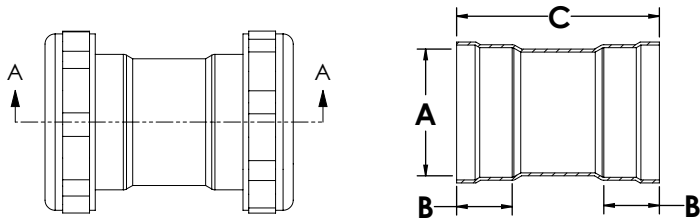

### FEATURES & MATERIALS

**Finish:** Chrome Plated

**Material:** 20 Gauge Brass

#### Double Slip Joint Connector:

- (1) Connector
- (2) Zinc Nuts
- (2) Rubber Washers

PRODUCT NO.	DESCRIPTION	CTN. QTY.	SIZE A	SIZE B	SIZE C	GAUGE
793C-1	Double Slip Joint Connection - 20 Ga	10	1.25	0.59	2.00	20



## 1-1/2" DOUBLE SLIP JOINT CONNECTION

### SPECIFICATIONS

Dearborn Brass 1-1/2" Double Slip Joint Connectors are designed for use in tubular drain applications.

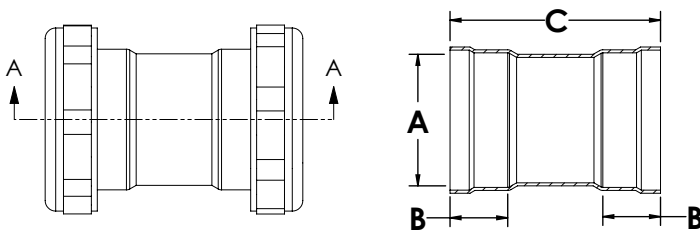

### FEATURES & MATERIALS

**Finish:** Chrome Plated

**Material:** 20 Gauge Brass

#### Double Slip Joint Connector:

- (1) Connector
- (2) Zinc Nuts
- (2) Rubber Washers

PRODUCT NO.	DESCRIPTION	CTN. QTY.	SIZE A	SIZE B	SIZE C	GAUGE
793D-1	Double Slip Joint Connection - 20 Ga.	10	1.50	0.59	2.00	20





## 1-1/4" SLIP JOINT CONNECTION - 45 DEGREES

### SPECIFICATIONS

Dearborn Brass 1-1/4" Brass Tubular Slip Joint Connections are designed for use in tubular drain applications.

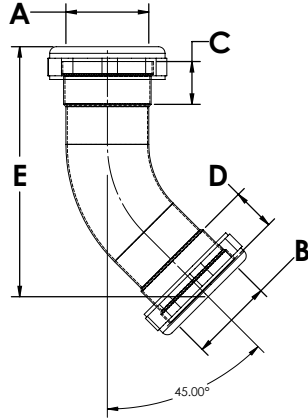

### FEATURES & MATERIALS

**Finish:** Chrome Plated

**Material:** 20 Gauge Brass

#### 1-1/4" Slip Joint Connection:

- (1) Connector
- (2) Nuts
- (2) Rubber Washers

PRODUCT NO.	DESCRIPTION	CTN. QTY.	SIZE A	SIZE B	SIZE C	SIZE D	SIZE E	GAUGE
8477	45 Degree Slip Joint Elbow, Chrome - 20 Ga.	5	1.25	1.25	0.66	0.66	3.50	20



## 1-1/2" SLIP JOINT CONNECTION - 45 DEGREES

### SPECIFICATIONS

Dearborn Brass 1-1/2" Brass Tubular Slip Joint Connections are designed for use in tubular drain applications.

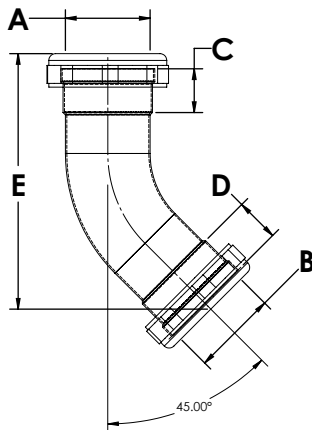

### FEATURES & MATERIALS

**Finish:** Chrome Plated

**Material:** 20 Gauge Brass

#### 1-1/2" Slip Joint Connection:

- (1) Connector
- (2) Nuts
- (2) Rubber Washers

PRODUCT NO.	DESCRIPTION	CTN. QTY.	SIZE A	SIZE B	SIZE C	SIZE D	SIZE E	GAUGE
8478	45 Degree Slip Joint Elbow, Chrome - 20 Ga.	5	1.50	1.50	0.71	0.71	3.50	20



## 1-1/4" SLIP JOINT CONNECTION - 90 DEGREES

### SPECIFICATIONS

Dearborn Brass 1-1/4" Brass Tubular Slip Joint Connections are designed for use in tubular drain applications.

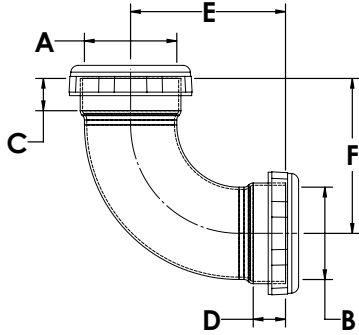

### FEATURES & MATERIALS

**Finish:** Chrome Plated

**Material:** 20 Gauge Brass

#### Double Slip Joint Connector:

- (1) Connector
- (2) Zinc Nuts
- (2) Rubber Washers

PRODUCT NO.	DESCRIPTION	CTN. QTY.	SIZE A	SIZE B	SIZE C	SIZE D	SIZE E	SIZE E	GAUGE
8482	90 Degree Slip Joint Elbow, Chrome - 20 Ga.	5	1.25	1.25	0.58	0.58	2.44	2.44	20



## 1-1/2" SLIP JOINT CONNECTION - 90 DEGREES

### SPECIFICATIONS

Dearborn Brass 1-1/2" Brass Tubular Slip Joint Connections are designed for use in tubular drain applications.

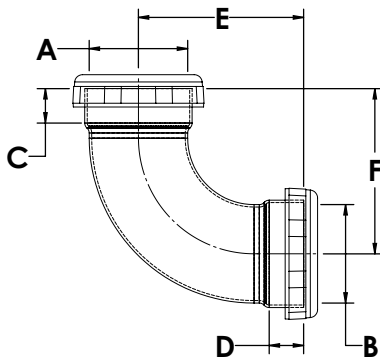

### FEATURES & MATERIALS

**Finish:** Chrome Plated

**Material:** 20 Gauge Brass

#### Double Slip Joint Connector:

- (1) Connector
- (2) Zinc Nuts
- (2) Rubber Washers

PRODUCT NO.	DESCRIPTION	CTN. QTY.	SIZE A	SIZE B	SIZE C	SIZE D	SIZE E	SIZE E	GAUGE
8483	90 Degree Slip Joint Elbow, Chrome - 20 Ga	5	1.50	1.50	0.50	0.50	2.50	2.50	20



## 1-1/4" SLIP JOINT CONNECTION - TEE

### SPECIFICATIONS

Dearborn Brass 1-1/4" Brass Tubular Slip Joint Connection Tees are designed for use in tubular drain applications.

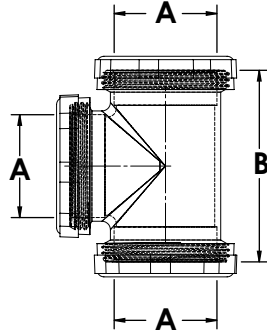

### FEATURES & MATERIALS

**Finish:** Chrome Plated

**Material:** 20 Gauge Brass

#### 1-1/4" Slip Joint Connection - Tee:

- (1) Connector
- (2) Nuts
- (2) Rubber Washers
- (3) Nuts
- (3) Rubber Washers

PRODUCT NO.	DESCRIPTION	CTN. QTY.	SIZE A	SIZE B	GAUGE
8482	90 Degree Slip Joint Elbow, Chrome - 20 Ga.	5	1.25	1.25	20



## 1-1/2" SLIP JOINT CONNECTION - TEE

### SPECIFICATIONS

Dearborn Brass 1-1/2" Brass Tubular Slip Joint Connection Tees are designed for use in tubular drain applications.

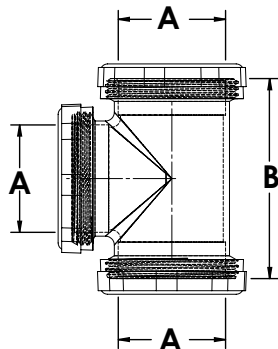

### FEATURES & MATERIALS

**Finish:** Chrome Plated

**Material:** 20 Gauge Brass

#### 1-1/2" Slip Joint Connection - Tee:

- (1) Connector
- (3) Nuts
- (3) Rubber Washers

PRODUCT NO.	DESCRIPTION	CTN. QTY.	SIZE A	SIZE B	GAUGE
8481	Tee Slip Joint, Chrome - 20 Ga.	5	1.50	2.82	20



## PATENT OVERFLOW & CENTER OUTLET PLUGS

### SPECIFICATIONS

Dearborn Brass Two Piece Patent Overflow Plug is designed for use in tubular drain applications with lavatory sinks. Available in 5", 6" 8" or 12" lengths.

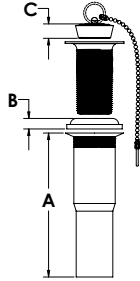

### FEATURES & MATERIALS

**Finish:** Chrome Plated

**Material:** 20 Gauge Brass

#### Two piece assembly:

- (1) Tailpiece
- (1) Flange
- (1) Friction Washer
- (1) Sloped Gasket
- (1) Chain & Plug
- (1) Nut

PRODUCT NO.	SIZE	DESCRIPTION	CTN. QTY.	SIZE A	SIZE B	SIZE C	GAUGE
2763-1	1-1/4" x 5"	Patent Overflow Plug Ind. Boxed 1 Pc. - 20 Ga.	10	5.00	0.38	0.52	20
2764A-1	1-1/4" x 8"	Patent Overflow Plug Ind. Boxed 1 Pc. - 20 Ga.	10	8.00	0.38	0.52	20
2765-1	1-1/4" x 12"	Patent Overflow Plug Ind. Boxed 1 Pc. - 20 Ga.	10	12.00	0.38	0.52	20
763-1	1-1/4" x 5"	Patent Overflow Plug Ind. Boxed 2 Pc. - 20 Ga.	10	5.00	0.38	0.52	20
763K-1	1-1/4" x 5"	Center Outlet Plug Ind. Boxed 2 Pc. Less Overflow - 20 Ga.	10	5.00	0.38	0.52	20
764-1	1-1/4" x 6"	Patent Overflow Plug Ind. Boxed 2 Pc. - 20 Ga.	10	6.00	0.38	0.52	20
764A-1	1-1/4" x 8"	Patent Overflow Plug Ind. Boxed 2 Pc. - 20 Ga.	10	8.00	0.38	0.52	20
765-1	1-1/4" x 12"	Patent Overflow Plug Ind. Boxed 2 Pc. - 20 Ga.	10	12.00	0.38	0.52	20



## CAST BRASS FLANGES WITH SET SCREW

### SPECIFICATIONS

Dearborn Brass Cast Brass Flange with Set Screw for use with tubular installations.

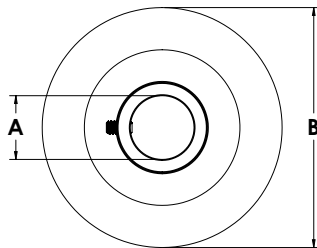

### FEATURES & MATERIALS

**Finish:** Chrome Plated

**Material:** Cast Brass

#### Cast Brass Flange:

- (1) Cast Brass Flange
- (1) Set Screw

PRODUCT NO.	SIZE	DESCRIPTION	CTN. QTY.	SIZE A	SIZE B
1119-1	3/8"	NPT Cast Brass Flange w/ Set Screw	12	0.375	2.50
1119A-1	1/2"	NPT Cast Brass Flange w/ Set Screw	12	0.50	2.50
1119D-1	5/8"	O.D. Cast Brass Flange w/ Set Screw	12	0.625	2.375
1121A-1	1-1/4"	O.D. Cast Brass Deep Flange w/ Set Screw	12	1.25	3.00
1121B-1	1-1/2"	O.D. Cast Brass Deep Flange w/ Set Screw	12	1.50	3.00



## SEMI-CAST GRID PATENT OVERFLOW PLUGS

### SPECIFICATIONS

Dearborn Brass Two Piece Patent Overflow Plug is designed for use in tubular drain applications with lavatory sinks. Two piece design allows overflow to flow to sink drain. Available in 5", 6" 8" or 12" lengths.



### APPROVALS & LISTINGS

cUPC (17 Ga. items)

### FEATURES & MATERIALS

**Finish:** Chrome Plated

**Material:** Semi-Cast Brass

#### Semi-Cast Grid Patent Overflow Plug:

- (1) Tailpiece
- (1) Flange
- (1) Friction Washer
- (1) Sloped Gasket
- (1) Cast Grid
- (1) Nut

PRODUCT NO.	SIZE	DESCRIPTION	CTN. QTY.	SIZE A	SIZE B	SIZE C	SIZE D	GAUGE
760-1	1-1/4" x 6"	Semi-Cast Grid Patent Overflow Plug w/ 1-1/4" x 6" - 17 Ga. Tailpiece	25	2.20	1.25	2.80	6.00	17
761-1	1-1/2" x 6"	Semi-Cast Grid Patent Overflow Plug w/ 1-1/2" x 6" - 17 Ga. Tailpiece	25	2.20	1.50	2.80	6.00	20



## SEMI-CAST GRID WHEELCHAIR PATENT OVERFLOW PLUG

### SPECIFICATIONS

Dearborn Brass Semi-Cast Wheelchair Grid Patent Overflow Plug with 1-1/4" – 17 gauge tailpiece. Designed for installation in most commercial applications.

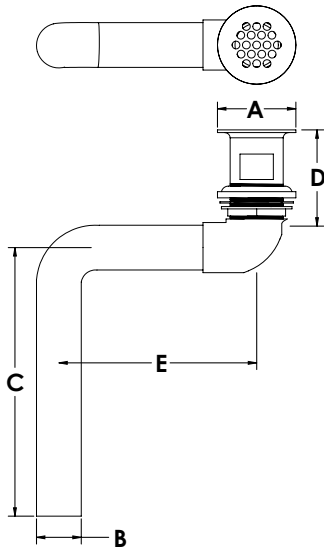

### APPROVALS & LISTINGS

cUPC

### FEATURES & MATERIALS

**Finish:** Chrome Plated

**Material:** Semi-Cast Brass

#### Semi-Cast Grid Wheelchair Patent Overflow Plug:

- (1) Cast Grid
- (1) P.O. Plug with nuts and washers
- (1) 90° Elbow
- (1) 17 gauge tailpiece

PRODUCT NO.	SIZE	DESCRIPTION	CTN. QTY.	SIZE A	SIZE B	SIZE C	SIZE D	SIZE E	GAUGE
760W-1	1-1/4"	Semi-Cast Grid Wheelchair Patent Overflow Plug w/ 1-1/4" - 17 Ga. Tailpiece	10	2.20	1.25	5.30	2.80	7.50	17



## 1-1/4" GRAB BARS WITH EXPOSED FLANGES, SATIN FINISH

### SPECIFICATIONS

Dearborn Brass Stainless Steel Grab Bars are designed for use in hospitals, hotels, government facilities, commercial building and residential home settings. ADA Compliant.

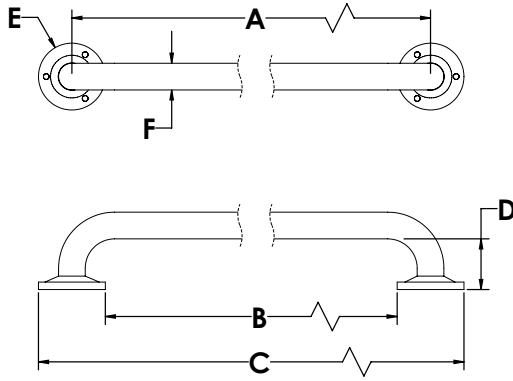

### APPROVALS & LISTINGS

ASTM F 446 with 1-1/2" clearance  
ANSI A117.1

### FEATURES & MATERIALS

**Finish:** Satin Finish

**Material:** Bar: 18 ga. 304 Stainless Steel

Flange: 14 ga. 304 Stainless Steel

Screws: #10 x 2" Self Tapping Stainless Steel

PRODUCT NO.	SIZE	DESCRIPTION	CTN. QTY.	SIZE A	SIZE B	SIZE C	SIZE D	SIZE E	SIZE F
DB7416	1-1/4" x 16"	Stainless Steel Grab Bar w/ Exposed Flange, Satin Finish	4	16.00	13.00	19.00	1.75	3.00	1.25
DB7424	1-1/4" x 24"	Stainless Steel Grab Bar w/ Exposed Flange, Satin Finish	4	24.00	21.00	27.00	1.75	3.00	1.25
DB7436	1-1/4" x 36"	Stainless Steel Grab Bar w/ Exposed Flange, Satin Finish	4	36.00	33.00	39.00	1.75	3.00	1.25
DB7442	1-1/4" x 42"	Stainless Steel Grab Bar w/ Exposed Flange, Satin Finish	4	42.00	39.00	45.00	1.75	3.00	1.25



## 1-1/2" GRAB BARS WITH EXPOSED FLANGES, SATIN FINISH

### SPECIFICATIONS

Dearborn Brass Stainless Steel Grab Bars are designed for use in hospitals, hotels, government facilities, commercial building and residential home settings. ADA Compliant.

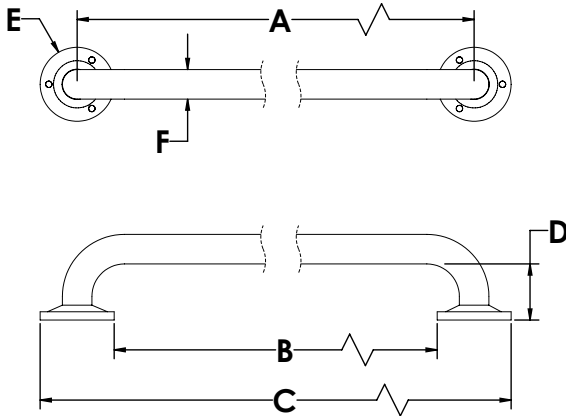

### APPROVALS & LISTINGS

ASTM F 446 with 1-1/2" clearance  
ANSI A117.1

### FEATURES & MATERIALS

**Finish:** Satin Finish

**Material:** Bar: 18 ga. 304 Stainless Steel

Flange: 14 ga. 304 Stainless Steel

Screws: #10 x 2" Self Tapping Stainless Steel

PRODUCT NO.	SIZE	DESCRIPTION	CTN. QTY.	SIZE A	SIZE B	SIZE C	SIZE D	SIZE E	SIZE F
DB7518	1-1/2" x 18"	Stainless Steel Grab Bar w/ Exposed Flange, Satin Finish	4	18.00	15.00	21.00	1.75	3.00	1.50
DB7524	1-1/2" x 24"	Stainless Steel Grab Bar w/ Exposed Flange, Satin Finish	4	24.00	21.00	27.00	1.75	3.00	1.50
DB7532	1-1/2" x 32"	Stainless Steel Grab Bar w/ Exposed Flange, Satin Finish	4	32.00	29.00	35.00	1.75	3.00	1.50
DB7536	1-1/2" x 36"	Stainless Steel Grab Bar w/ Exposed Flange, Satin Finish	4	36.00	33.00	39.00	1.75	3.00	1.50
DB7542	1-1/2" x 42"	Stainless Steel Grab Bar w/ Exposed Flange, Satin Finish	4	42.00	39.00	45.00	1.75	3.00	1.50





## 1-1/4" GRAB BARS WITH CONCEALED FLANGES, SATIN FINISH

### SPECIFICATIONS

Dearborn Brass Stainless Steel Grab Bars are designed for use in hospitals, hotels, government facilities, commercial building and residential home settings. ADA Compliant.

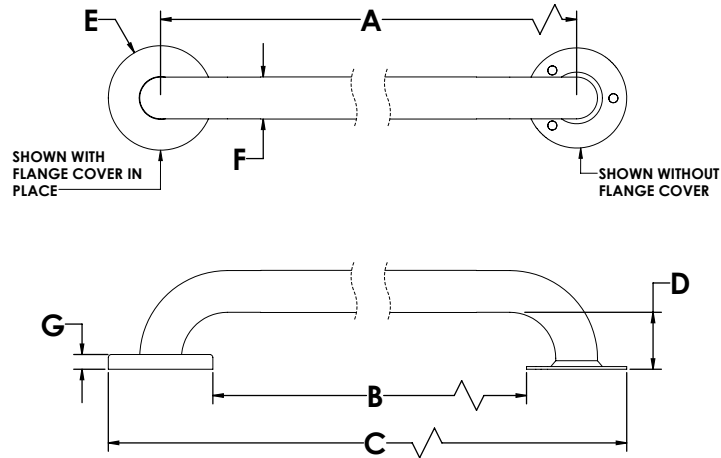

### APPROVALS & LISTINGS

ASTM F 446 with 1-1/2" clearance  
ANSI A117.1

### FEATURES & MATERIALS

**Finish:** Satin Finish

**Material:** Bar: 18 ga. 304 Stainless Steel

Flange: 14 ga. 304 Stainless Steel

Screws: #10 x 2" Self Tapping Stainless Steel

PRODUCT NO.	SIZE	DESCRIPTION	CTN. QTY.	SIZE A	SIZE B	SIZE C	SIZE D	SIZE E	SIZE F	SIZE G
DB8712	1-1/4" x 12"	Stainless Steel Grab Bar w/ Concealed Flange, Satin Finish	4	12.00	9.00	15.00	1.75	3.00	1.25	0.44
DB8716	1-1/4" x 16"	Stainless Steel Grab Bar w/ Concealed Flange, Satin Finish	4	16.00	13.00	19.00	1.75	3.00	1.25	0.44
DB8718	1-1/4" x 18"	Stainless Steel Grab Bar w/ Concealed Flange, Satin Finish	4	18.00	15.00	21.00	1.75	3.00	1.25	0.44
DB8724	1-1/4" x 24"	Stainless Steel Grab Bar w/ Concealed Flange, Satin Finish	4	24.00	21.00	27.00	1.75	3.00	1.25	0.44
DB8730	1-1/4" x 30"	Stainless Steel Grab Bar w/ Concealed Flange, Satin Finish	4	30.00	27.00	33.00	1.75	3.00	1.25	0.44
DB8732	1-1/4" x 32"	Stainless Steel Grab Bar w/ Concealed Flange, Satin Finish	4	32.00	29.00	35.00	1.75	3.00	1.25	0.44
DB8736	1-1/4" x 36"	Stainless Steel Grab Bar w/ Concealed Flange, Satin Finish	4	36.00	33.00	39.00	1.75	3.00	1.25	0.44
DB8742	1-1/4" x 42"	Stainless Steel Grab Bar w/ Concealed Flange, Satin Finish	4	42.00	39.00	45.00	1.75	3.00	1.25	0.44
DB8748	1-1/4" x 48"	Stainless Steel Grab Bar w/ Concealed Flange, Satin Finish	4	48.00	45.00	51.00	1.75	3.00	1.25	0.44



## 1-1/2" GRAB BARS WITH CONCEALED FLANGES, SATIN FINISH

### SPECIFICATIONS

Dearborn Brass Stainless Steel Grab Bars are designed for use in hospitals, hotels, government facilities, commercial building and residential home settings. ADA Compliant.

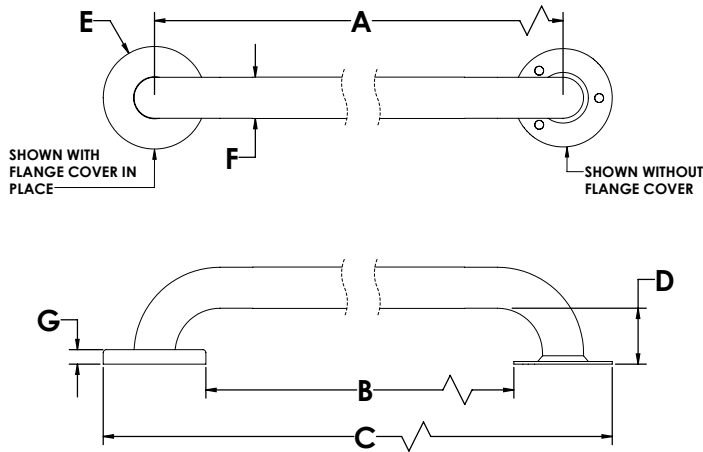

### APPROVALS & LISTINGS

ASTM F 446 with 1-1/2" clearance  
ANSI A117.1

### FEATURES & MATERIALS

**Finish:** Satin Finish

**Material:** Bar: 18 ga. 304 Stainless Steel

Flange: 14 ga. 304 Stainless Steel

Screws: #10 x 2" Self Tapping Stainless Steel

PRODUCT NO.	SIZE	DESCRIPTION	CTN. QTY.	SIZE A	SIZE B	SIZE C	SIZE D	SIZE E	SIZE F
DB8912	1-1/2" x 12"	Stainless Steel Grab Bar w/ Concealed Flange, Satin Finish	4	12.00	9.00	15.00	3.00	1.50	0.44
DB8916	1-1/2" x 16"	Stainless Steel Grab Bar w/ Concealed Flange, Satin Finish	4	16.00	13.00	19.00	3.00	1.50	0.44
DB8918	1-1/2" x 18"	Stainless Steel Grab Bar w/ Concealed Flange, Satin Finish	4	18.00	15.00	21.00	3.00	1.50	0.44
DB8924	1-1/2" x 24"	Stainless Steel Grab Bar w/ Concealed Flange, Satin Finish	4	24.00	21.00	27.00	3.00	1.50	0.44
DB8930	1-1/2" x 30"	Stainless Steel Grab Bar w/ Concealed Flange, Satin Finish	4	30.00	27.00	33.00	3.00	1.50	0.44
DB8932	1-1/2" x 32"	Stainless Steel Grab Bar w/ Concealed Flange, Satin Finish	4	32.00	29.00	35.00	3.00	1.50	0.44
DB8936	1-1/2" x 36"	Stainless Steel Grab Bar w/ Concealed Flange, Satin Finish	4	36.00	33.00	39.00	3.00	1.50	0.44
DB8942	1-1/2" x 42"	Stainless Steel Grab Bar w/ Concealed Flange, Satin Finish	4	42.00	39.00	45.00	3.00	1.50	0.44
DB8948	1-1/2" x 48"	Stainless Steel Grab Bar w/ Concealed Flange, Satin Finish	4	48.00	45.00	51.00	3.00	1.50	0.44



## 1-1/4" GRAB BARS WITH CONCEALED FLANGES, PEENED FINISH

### SPECIFICATIONS

Dearborn Brass Stainless Steel Grab Bars are designed for use in hospitals, hotels, government facilities, commercial building and residential home settings. ADA Compliant.

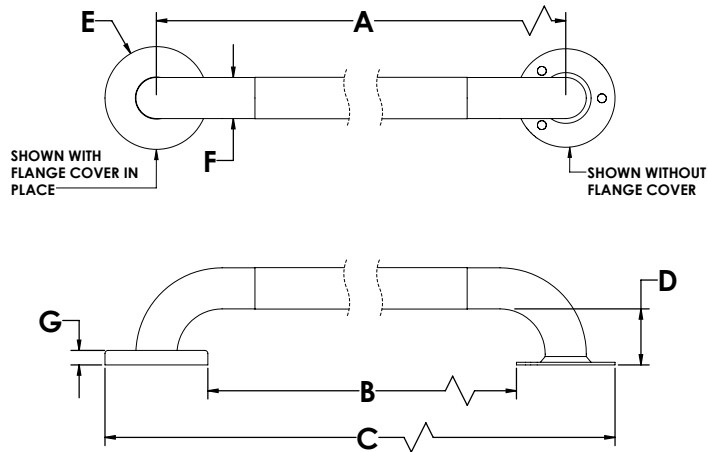

### APPROVALS & LISTINGS

ASTM F 446 with 1-1/2" clearance  
ANSI A117.1

### FEATURES & MATERIALS

**Finish:** Peened Finish

**Material:** Bar: 18 ga. 304 Stainless Steel

Flange: 14 ga. 304 Stainless Steel

Screws: #10 x 2" Self Tapping Stainless Steel

PRODUCT NO.	SIZE	DESCRIPTION	CTN. QTY.	SIZE A	SIZE B	SIZE C	SIZE D	SIZE E	SIZE F	SIZE G
DB8712P	1-1/4" x 12"	Stainless Steel Grab Bar w/ Concealed Flange, Peened Finish	4	12.00	9.00	15.00	1.75	3.00	1.25	0.44
DB8716P	1-1/4" x 16"	Stainless Steel Grab Bar w/ Concealed Flange, Peened Finish	4	16.00	13.00	19.00	1.75	3.00	1.25	0.44
DB8724P	1-1/4" x 24"	Stainless Steel Grab Bar w/ Concealed Flange, Peened Finish	4	24.00	21.00	27.00	1.75	3.00	1.25	0.44
DB8736P	1-1/4" x 36"	Stainless Steel Grab Bar w/ Concealed Flange, Peened Finish	4	36.00	33.00	39.00	1.75	3.00	1.25	0.44
DB8742P	1-1/4" x 42"	Stainless Steel Grab Bar w/ Concealed Flange, Peened Finish	4	42.00	39.00	45.00	1.75	3.00	1.25	0.44



## 1-1/2" GRAB BARS WITH CONCEALED FLANGES, PEENED FINISH

### SPECIFICATIONS

Dearborn Brass Stainless Steel Grab Bars are designed for use in hospitals, hotels, government facilities, commercial building and residential home settings. ADA Compliant.

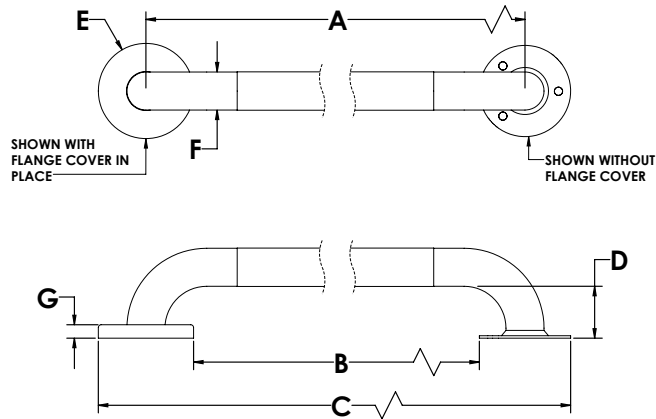

### APPROVALS & LISTINGS

ASTM F 446 with 1-1/2" clearance  
ANSI A117.1

### FEATURES & MATERIALS

**Finish:** Peened Finish

**Material:** Bar: 18 ga. 304 Stainless Steel

Flange: 14 ga. 304 Stainless Steel

Screws: #10 x 2" Self Tapping Stainless Steel

PRODUCT NO.	SIZE	DESCRIPTION	CTN. QTY.	SIZE A	SIZE B	SIZE C	SIZE D	SIZE E	SIZE F	SIZE G
DB8918P	1-1/2" x 18"	Stainless Steel Grab Bar w/ Concealed Flange, Peened Finish	4	18.00	15.00	21.00	1.75	3.00	1.50	0.44
DB8924P	1-1/2" x 24"	Stainless Steel Grab Bar w/ Concealed Flange, Peened Finish	4	24.00	21.00	27.00	1.75	3.00	1.50	0.44
DB8932P	1-1/2" x 32"	Stainless Steel Grab Bar w/ Concealed Flange, Peened Finish	4	32.00	29.00	35.00	1.75	3.00	1.50	0.44
DB8936P	1-1/2" x 36"	Stainless Steel Grab Bar w/ Concealed Flange, Peened Finish	4	36.00	33.00	39.00	1.75	3.00	1.50	0.44
DB8942P	1-1/2" x 42"	Stainless Steel Grab Bar w/ Concealed Flange, Peened Finish	4	42.00	39.00	45.00	1.75	3.00	1.50	0.44
DB8948P	1-1/2" x 48"	Stainless Steel Grab Bar w/ Concealed Flange, Peened Finish	4	48.00	45.00	51.00	1.75	3.00	1.50	0.44

**SUPPLY  
BOXES**

WASHING MACHINE OUTLET BOX

TWO PIECE VALVES

JOB-SITE READY

**RUGGED**

FLEXIBILITY

CONTRACTOR

CONNECTION TYPES

REDEFINING

EASE OF USE

SURE-VENT

**STURDY**

PRODUCTIVITY

EASE OF USE

**FLEXIBILITY**

INFINITE SOLUTIONS

REINFORCED

**RELIABLE**

CONFIGURATION OPTIONS

**COMPLIANT**

UNIVERSAL PLATFORM

SPEED

**Oatey**

**COMMERCIAL**

EASY ASSEMBLY

**FIRE-RATED**

**VERSATILE**

READY TO USE

COSMO

MULTIPLE APPLICATIONS

**FASTER INSTALL**

**QUADTRO**

INTEGRATED

WATER HAMMER ARRESTORS

ICE MAKER OUTLET BOX

**MODA**

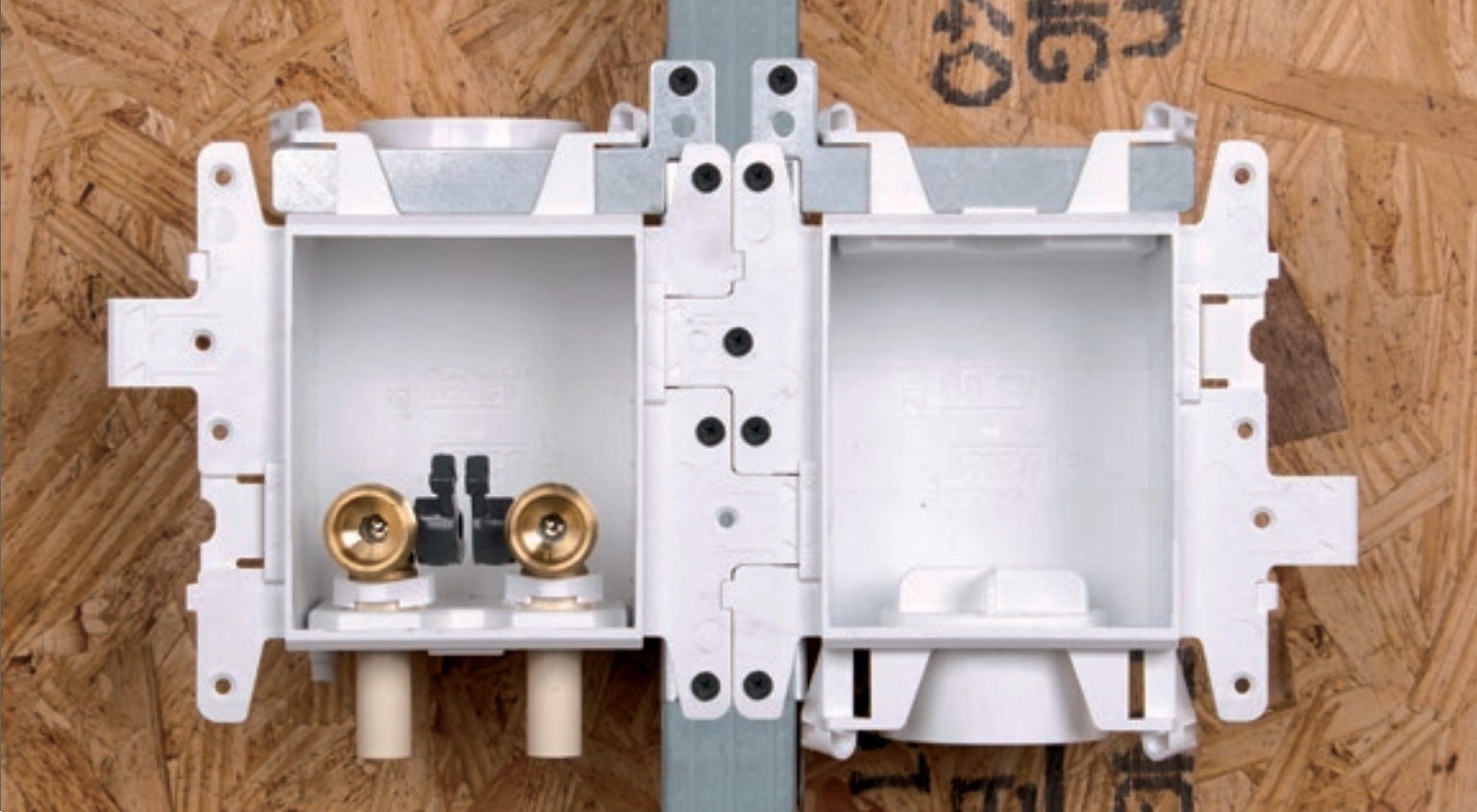
**Oatey**

# SUPPLY BOXES

**CHOOSE STANDARD PLASTIC, METAL OR FIRE-RATED.**

Oatey® supply boxes can be used in commercial or residential applications that require supply valves and waste drains recessed into the wall. Available configurations include Kitchen, Dishwasher, Ice Maker, Washing Machine, Lavatory, Toilet and Air Admittance Valves. Plus, the available water hammer arrestor option provides water pressure shock arrestors required for installation on supply lines to quick closing valves.

## CENTRO II WASHING MACHINE OUTLET BOXES

### SPECIFICATIONS

Oatey's Centro II Washing Machine Box is used for commercial and residential washing machine applications. It can be mounted with the valves on the top or bottom and comes with two support brackets and two piece uninstalled valves.

- Takes up less space and will fit almost anywhere.
- WMOB made of PVC.
- Brackets and Faceplate made of HIPS.
- 2 knockout drain caps.
- 2" Socket Hubs.
- Mountable with valves on top or bottom.
- 2 piece valves come uninstalled or installed.
- Two support brackets.
- Available in a wide variety of tailpiece configurations and packaging options.

PRODUCT NO.	DESCRIPTION	CTN. QTY.
<b>No Hammer Assembled</b>		
38100	1/4 Turn, Copper, No Hammer, Assembled, Standard Pack	12
38102	1/4 Turn, CPVC, No Hammer, Assembled, Standard Pack	12
38104	1/4 Turn, ASTM F1807, No Hammer, Assembled, Standard Pack	12
38106	1/4 Turn, ASTM F1960, No Hammer, Assembled, Standard Pack	12
38150	1/4 Turn, Copper, No Hammer, Assembled, Contractor Pack	12
38153	1/4 Turn, CPVC, No Hammer, Assembled, Contractor Pack	12
38151	1/4 Turn, ASTM F1807, No Hammer, Assembled, Contractor Pack	12
38152	1/4 Turn, ASTM F1960, No Hammer, Assembled, Contractor Pack	12
38322	1/4 Turn, Push Connect, No Hammer, Assembled, Contractor Pack	12
38334	1/4 Turn, Viega, No Hammer, Standard Pack	12
38335	1/4 Turn, Viega, No Hammer, Standard Pack	12
38342	1/4 Turn, Viega, No Hammer, Contractor Pack	12
<b>Hammer Assembled</b>		
38101	1/4 Turn, Copper, Hammer, Assembled, Standard Pack	12
38103	1/4 Turn, CPVC, Hammer, Assembled, Standard Pack	12
38105	1/4 Turn, ASTM F1807, Hammer, Assembled, Standard Pack	12
38107	1/4 Turn, ASTM F1960, Hammer, Assembled, Standard Pack	12
38154	1/4 Turn, Copper, Hammer, Assembled, Contractor Pack	12
38157	1/4 Turn, CPVC, Hammer, Assembled, Contractor Pack	12
38155	1/4 Turn, ASTM F1807, Hammer, Assembled, Contractor Pack	12
38156	1/4 Turn, ASTM F1960, Hammer, Assembled, Contractor Pack	12
38323	1/4 Turn, Push Connect, Hammer, Assembled, Contractor Pack	12
<b>No Hammer Unassembled</b>		
38108	1/4 Turn, Copper, No Hammer, Unassembled, Standard Pack	12
38110	1/4 Turn, CPVC, No Hammer, Unassembled, Standard Pack	12
38112	1/4 Turn, ASTM F1807, No Hammer, Unassembled, Standard Pack	12
38114	1/4 Turn, ASTM F1960, No Hammer, Unassembled, Standard Pack	12
<b>Hammer Unassembled</b>		
38111	1/4 Turn, CPVC, Hammer, Unassembled, Standard Pack	12
38113	1/4 Turn, F1807, Hammer, Unassembled, Standard Pack	12
38115	1/4 Turn, F1960, Hammer, Unassembled, Standard Pack	12
<b>Plain Boxes</b>		
38120	Plain Box, Display Pack	4
38121	Plain Box, Standard Pack	12
<b>Accessories</b>		
38381	Centro II, Plastic Faceplate	12
38383	Brackets 12" Long Plastic	12
38294	Hot/Cold Temperature Indicator Clips for Supply Valves (12 Red, 12 Blue)	24

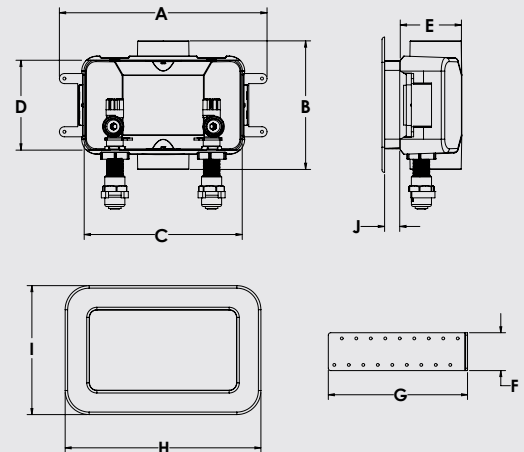
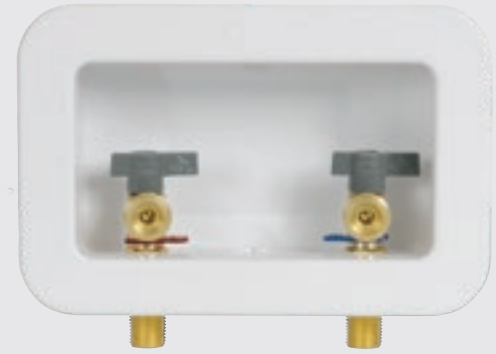

### DIMENSIONS

- A:** Box Width 10.30"
- B:** Box Height 6.38"
- C:** Box Opening Width 7.84"
- D:** Box Opening Height 4.46"
- E:** Box Depth 3.03"
- F:** Bracket Height 1.97"
- G:** Bracket Width 7.25"
- H:** Faceplate Width 10.19"
- I:** Faceplate Height 6.71"
- J:** Faceplate Depth 0.75"

*STANDARD PACK: Faceplates are pre-assembled on box.*

*CONTRACTOR PACK: Faceplates are NOT pre-assembled on box (but come separately packed with the box).*



## QUADTRO® WASHING MACHINE OUTLET BOXES

### SPECIFICATIONS

Oatey QUADTRO® Washing Machine Outlet Boxes shall be used in commercial or residential applications which require supply valves and waste drains recessed into the wall. Available water hammer arrestor option provides water pressure shock arrestors required for installation on supply lines to quick closing valves. Easy to remove knockout.

- 2" drain opening fits PVC or ABS Sch. 40 DWV pipe
- All washing machine outlet boxes are shipped 12 per carton
- Box made of high impact polystyrene
- 4 support brackets included for mounting
- Snap-on faceplate frame accommodates up to 1" drywall

PRODUCT NO.	DESCRIPTION	CTN. QTY.
<b>Washing Machine Outlet Boxes</b>		
38330	1/4 Turn, Viega, No Hammer – Standard Pack	12
38331	1/4 Turn, Viega, Hammer – Standard Pack	12
38338	1/4 Turn, Viega, No Hammer – Contractor Pack	12
38350	1/4 Turn, Single Lever, Viega, Standard Pack	12
38530	1/4 Turn Brass Ball Valve – Copper Sweat – Standard Pack	12
38531	1/4 Turn Brass Ball Valve – CPVC – Standard Pack	12
38532	1/4 Turn Brass Ball Valve – ASTM F1807 PEX – Standard Pack	12
38533	1/4 Turn Brass Ball Valve – ASTM F1960 PEX – Standard Pack	12
38535	Single Lever Ball Valve – Copper Sweat – Standard Pack	12
38536	Single Lever Ball Valve – CPVC – Standard Pack	12
38537	Single Lever Ball Valve – ASTM F1807 PEX – Standard Pack	12
38538	Single Lever Ball Valve – ASTM F1960 PEX – Standard Pack	12
38539	Single Lever Ball Valve – ASTM F1974 PEX – Standard Pack	12
38540	1/4 Turn Brass Hammer Ball Valve – Copper Sweat – Standard Pack	12
38541	1/4 Turn Brass Hammer Ball Valve – CPVC – Standard Pack	12
38542	1/4 Turn Brass Hammer Ball Valve – ASTM F1807 PEX – Standard Pack	12
38543	1/4 Turn Brass Hammer Ball Valve – ASTM F1960 PEX – Standard Pack	12
38544	1/4 Turn Brass Hammer Ball Valve – ASTM F1974 PEX – Standard Pack	12
38545	Single Lever Hammer Ball Valve – Copper Sweat – Standard Pack	12
38546	Single Lever Hammer Ball Valve – CPVC – Standard Pack	12
38547	Single Lever Hammer Ball Valve – ASTM F1807 PEX – Standard Pack	12
38548	Single Lever Hammer Ball Valve – ASTM F1960 PEX – Standard Pack	12
38550	Plain Box – No Valves – Standard Pack	12
38551	1/4 Turn Brass Ball Valve – Compression – Standard Pack	12
38552	Brass Boiler Drain Valve – Copper Sweat – Standard Pack	12
38555	1/4 Turn Brass Ball Valve – F2080 PEX – Standard Pack	12
38556	1/4 Turn Brass Ball Valve – 3/8" PEX – Standard Pack	12
38560	1/4 Turn Brass Ball Valve – Copper Sweat – Contractor Pack	12
38561	1/4 Turn Brass Ball Valve – CPVC – Contractor Pack	12
38562	1/4 Turn Brass Ball Valve – ASTM F1807 PEX – Contractor Pack	12
38563	1/4 Turn Brass Ball Valve – ASTM F1960 PEX – Contractor Pack	12
<b>Accessories</b>		
38941	Plastic Faceplate for Quadtro Center and Offset WMOB	12
38768	Plastic Brackets, 4" Long, for Plastic Boxes	12
38648	Plastic Brackets, 12" Long, for Plastic Boxes	12
38576	Quadtro Test Cap	12
38577	Quadtro Hug/O-ring	24



### APPROVALS & LISTINGS

**Valves:** ASME A112.18.1 / CSA B125.1 NSF / ANSI 61 & 372

**Water Hammer Arrestors:** ASSE 1010

**Boxes:** IAPMO-Listed

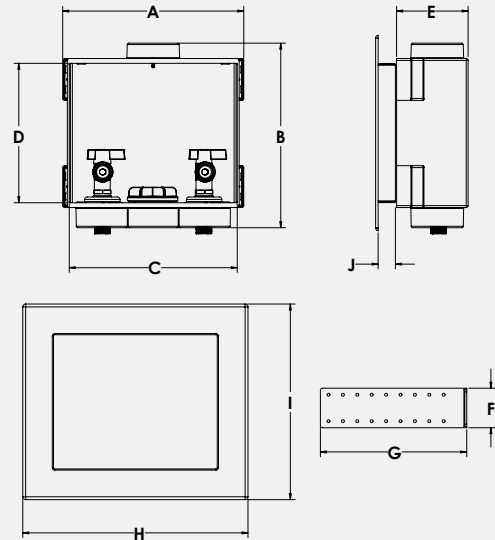

### DIMENSIONS

- A:** Box Width 9.43"
- B:** Box Height 9.61"
- C:** Box Opening Width 8.75"
- D:** Box Opening Height 7.26"
- E:** Box Depth 3.73"
- F:** Bracket Height 2.06"
- G:** Bracket Width 7.62"
- H:** Faceplate Width 11.73"
- I:** Faceplate Height 10.19"
- J:** Faceplate Depth 0.90"

*STANDARD PACK: Faceplates are pre-assembled on box.*

*CONTRACTOR PACK: Faceplates are NOT pre-assembled on box (but comes separately packed with the box).*

### ACCESSORY COMPONENTS INCLUDE:



Side Brackets (4)

Faceplate (1)

Test Plug (1)





## SPECIFICATIONS

Oatey Reversible Drain Metal Washing Machine Outlet Boxes can be used in commercial or residential applications which require supply valves and waste drains recessed into the wall. Available water hammer arrestor option provides water pressure shock arrestors required on supply lines to quick closing valves.

- 2" drain opening - rubber coupling or solvent weld
- All reversible metal washing machine outlet boxes are shipped 1 per carton
- Allows for left or right hand drain
- Box made of 20 gauge steel
- 2 support brackets
- Easy to remove ½" metal cap knockouts
- Screw-on faceplate frame accommodates up to 1" drywall
- Faceplate made of 18 gauge steel

PRODUCT NO.	DESCRIPTION	CTN. QTY.
<b>Reversible Metal Washing Machine Outlet Boxes</b>		
38979	1/4 Turn Brass Ball Valves – CPVC – Rubber Tailpiece – Standard Pack	1
38981	1/4 Turn Brass Ball Valves – Copper Sweat – PVC Tailpiece – Standard Pack	1
38982	Single Lever Turn Brass Ball Valve – Copper Sweat - PVC Tailpiece – Standard Pack	1
38983	1/4 Turn Brass Ball Valves – Copper Sweat – ABS Tailpiece – Standard Pack	1
38984	Single Lever Turn Brass Ball Valve – Copper Sweat – ABS Tailpiece – Standard Pack	1
38985	1/4 Turn Brass Ball Valves – Copper Sweat – 2" Rubber Tailpiece – Standard Pack	1
38986	Single Lever Turn Brass Ball Valve – Copper Sweat – 2" Rubber Tailpiece – Standard Pack	1
38993	1/4 Turn Brass Ball Valves – Copper Sweat – Metal 2" NPT Tailpiece – Standard Pack	1
38995	1/4 Turn Brass Hammer Ball Valves – Copper Sweat – 2" Rubber Tailpiece – Standard Pack	1
38996	1/4 Turn Brass Hammer Ball Valves – CPVC – With Grommets – Top Mount	1
<b>Accessories</b>		
38975	Metal Faceplate for Metal WMOB	1
38976	Metal Brackets for Metal WMOB	1
38990	2" Rubber Tailpiece for Metal WMOB	1
38980	Plain box – No valves – No Tailpiece – Standard Pack	1
38987	2" PVC Drain Tailpiece for Metal WMOB	1
38976	Metal Brackets for Metal WMOB	1



## APPROVALS & LISTINGS

Valves: ASME A112.18.1

Water Hammer Arrestors: ASSE 1010

Boxes: IAPMO-Listed

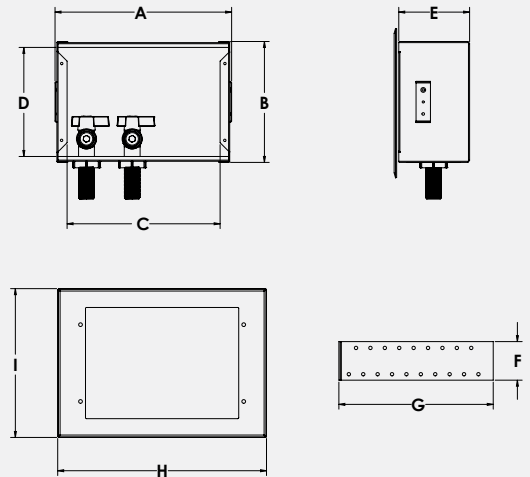

## DIMENSIONS

**A:** Box Width 9.20"

**B:** Box Height 6.30"

**C:** Box Opening Width 7.97"

**D:** Box Opening Height 5.68"

**E:** Box Depth 3.69"

**F:** Bracket Height 2.01"

**G:** Bracket Width 8.04"

**H:** Faceplate Width 10.88"

**I:** Faceplate Height 7.75"

*STANDARD PACK: Faceplates are pre-assembled on box.*

*CONTRACTOR PACK: Faceplates are NOT pre-assembled on box (but come separately packed with the box).*



## SQUARE ICE MAKER OUTLET BOXES

### SPECIFICATIONS

Oatey Ice Maker Boxes can be used in commercial or residential applications which require supply valves recessed into the wall. Available water hammer arrestor option provides water pressure shock arrestors required for installation on supply lines to quick closing valves.

- Provides quick, safe water supply and shut-off for refrigerator, ice maker and water dispenser
- Box made of high impact polystyrene
- 2 support brackets
- Snap-on faceplate frame accommodates up to 1" drywall

PRODUCT NO.	DESCRIPTION	CTN. QTY.
39156	Square, 1/4 Turn, Copper, Low Lead – Standard Pack	6
39157	Square, 1/4 Turn, Copper, Low Lead – Contractor Pack	12
39145	Square, 1/4 Turn, Copper, Low Lead – Standard Pack, 6' SS Hose	6
39155	Square, 1/4 Turn, CPVC, Low Lead – Standard Pack	6
39158	Square, 1/4 Turn, F1807, Low Lead – Standard Pack	6
39160	Square, 1/4 Turn, F1807, Low Lead – Contractor Pack	12
39146	Square, 1/4 Turn, F1807, Low Lead – Standard Pack, 6' SS Hose	6
39161	Square, 1/4 Turn, F1960, Low Lead – Standard Pack	6
38626	Square, 1/4 Turn, F1960, Low Lead – Contractor Pack	12
39154	Square, 1/4 Turn, F1960, Low Lead – Standard Pack, 6' SS Hose	6
39162	Square, Boiler Drain Copper, Low Lead, NAFTA – Standard Pack	6
39152	Square, 1/4 Turn, Copper, Hammer, Low Lead – Standard Pack	6
39151	1/4 Turn Brass Hammer Ball Valve, Low Lead – Copper Sweat – Display Box	6
39142	Square, 1/4 Turn, Copper, Hammer, Low Lead – Standard Pack, 6' SS Hose	6
39148	Square, 1/4 Turn, CPVC, Hammer, Low Lead – Standard Pack	6
39143	Square, 1/4 Turn, CPVC, Hammer, Low Lead – Standard Pack, 6' SS Hose	6
39149	Square, 1/4 Turn, F1807, Hammer, Low Lead – Standard Pack	6
38628	Square, 1/4 Turn, F1807, Hammer, Low Lead – Contractor Pack	12
39148	1/4 Turn Brass Hammer Ball Valve, Low Lead – CPVC – Standard	6
39159	Square 1/4 Turn CPVC, Low Lead - Contractor Pack	12
39150	Square, 1/4 Turn, F1960, Hammer, Low Lead – Standard Pack	6
38625	Square, 1/4 Turn, F1960, Hammer, Low Lead – Contractor Pack	12
39153	Square, 1/4 Turn, CPVC, Low Lead - Standard Pack, 6' SS Hose	6
Accessories		
38810	Square, Plain Box, No Valves – Standard Pack	6
38806	Square, Plain Box, No Valves, With Grommet – Standard Pack	6
38942	Square, Plastic Faceplate	24
38768	Brackets 4" Long Plastic	12
38648	Brackets 12" Long Plastic	12



### APPROVALS & LISTINGS

Valves: NSF 61, Section 9, ASME A112.18.1

Water Hammer Arrestors: ASSE 1010

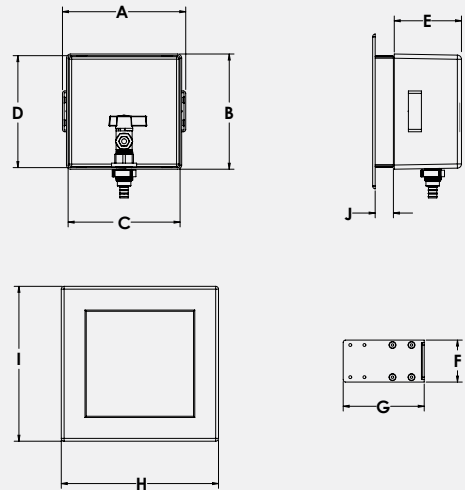

### DIMENSIONS

**A:** Box Width 6.42"

**B:** Box Height 6.00"

**C:** Box Opening Width 5.83"

**D:** Box Opening Height 5.83"

**E:** Box Depth 3.50"

**F:** Bracket Height 2.19"

**G:** Bracket Width 4.22"

**H:** Faceplate Width 8.19"

**I:** Faceplate Height 8.07"

**J:** Faceplate Depth 0.95"

*STANDARD PACK: Faceplates are pre-assembled on box.*

*CONTRACTOR PACK: Faceplates are NOT pre-assembled on box (but come separately packed with the box).*



## SPECIFICATIONS

Oatey's Ice Maker Supply Box with Hose can be used in commercial or residential applications which require supply valves recessed into the wall. The box includes 6' Stainless Steel Hose for connection to appliance.

- Provides quick, safe water supply and shut-off for refrigerator ice maker and water dispenser
- Stainless steel hose allows for easy connection to appliance
- Box made of high impact polystyrene
- Two support brackets
- Snap-on faceplate accommodates up to 1" drywall. Faceplate: 7-3/8" diameter

PRODUCT NO.	DESCRIPTION	CTN. QTY.
39265	Round IMOB 1/4 Turn Copper Contractor pack, SS Hose LL	12
39266	Round IMOB 1/4 Turn Copper Standard Pack, SS Hose LL	6
39267	Round IMOB 1/4 Turn CPVC Standard Pack, SS Hose LL	6
39207	1/4 Turn Brass Ball Valve - Low Lead - Copper Sweat - Standard Pack	6
39208	1/4 Turn Brass Ball Valve - Low Lead - CPVC - Standard Pack	6
39209	1/4 Turn Brass Ball Valve - Low Lead - 1/2" ASTM F1807 Pex - Standard Pack	6
39210	1/4 Turn Brass Ball Valve - Low Lead - 1/2" ASTM F 1960 Pex - Standard Pack	6
39211	1/4 Turn Brass Hammer Ball Valve - Low Lead - Copper Sweat - Standard Pack	6
39212	1/4 Turn Brass Hammer Ball Valve - Low Lead - CPVC - Standard Pack	6
39213	1/4 Turn Brass Hammer Ball Valve - Low Lead - 1/2" ASTM F1807 Pex - Standard Pack	6
39214	1/4 Turn, Round, F1960 Hammer, Low Lead - Standard Pack	6
39215	Round Ice Maker Outlet Box Faceplate	6
39216	Plain Box - Standard Pack - No Valve	6
38768	Brackets 4" Long Plastic	12
38648	Brackets 12" Long Plastic	12



## APPROVALS & LISTINGS

**Valves:** NSF Standard 61, Section 9, ASME A112.18.1

**Water Hammer Arrestors:** ASSE 1010

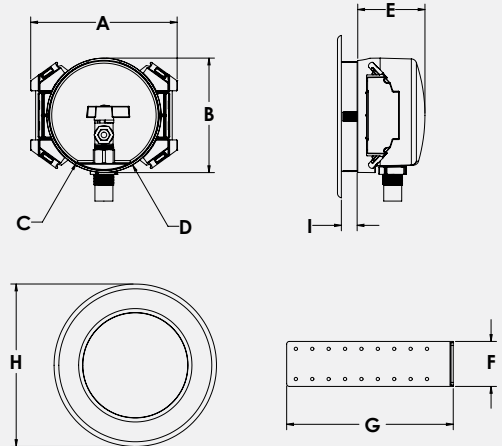

## DIMENSIONS

**A:** Box Width 6.70"

**B:** Box Height 5.24"

**C:** Box Opening Diameter 5.06"

**D:** Box Opening Diameter 5.22"

**E:** Box Depth 3.08"

**F:** Bracket Height 2.06"

**G:** Bracket Width 7.62"

**H:** Faceplate Width 7.43"

**I:** Faceplate Height 0.72"



## I2K® ICE MAKER OUTLET BOXES

### SPECIFICATIONS

Oatey Ice Maker Boxes can be used in commercial or residential applications which require supply valves recessed into the wall.

- Nails preloaded - no support bracket needed
- Right or left hand installation
- Box made of high impact polystyrene
- Valves comply with requirements of NSF 61, Section 9
- Available with Copper, CPVC, PEX and Push Connect connections
- Snap-on faceplate frame
- US Patent # D 428,117

PRODUCT NO.	DESCRIPTION	CTN. QTY.
<b>I2K® Ice Maker Box With Nails</b>		
39130	I2K, 1/4 Turn, Copper, Low Lead – Display Pack	4
39132	I2K, 1/4 Turn, F1960, Low Lead – Contractor Pack	12
39133	1/4 Turn Brass Ball Valve, Low Lead – CPVC Standard Pack	6
39134	1/4 Turn Brass Ball Valve, Low Lead – Copper Sweat – Standard Pack	6
39135	I2K, 1/4 Turn, Copper, Low Lead – Contractor Pack	12
39136	I2K, 1/4 Turn, F1807, Low Lead – Standard Pack	6
39137	I2K, 1/4 Turn, CPVC, Low Lead – Contractor Pack	12
39138	I2K, 1/4 Turn, F1807, Low Lead – Contractor Pack	12
39139	I2K, Boiler Drain, Copper, Low Lead, NAFTA – Standard Pack	6
39125	I2K, 1/4 Turn, Copper, Hammer, Low Lead – Standard Pack	12
39126	I2K, 1/4 Turn, CPVC, Hammer, Low Lead – Standard Pack	12
39127	I2K, 1/4 Turn, F1807, Hammer, Low Lead – Standard Pack	12
39128	I2K, 1/4 Turn, F1960, Hammer, Low Lead – Standard Pack	12
38312	I2K, 1/4 Turn Push Connect, No Hammer – Standard Pack	6
38313	1/4 Turn, Push Connect, Hammer, Assembled – Standard Pack	6
38320	I2K, 1/4 Turn Pursh Connect, No Hammer – Contractor Pack	12
38332	1/4 Turn, Viega, No Hammer – Standard Pack	6
38333	1/4 Turn, Viega, Hammer – Standard Pack	6
<b>Accessories</b>		
38622	Plastic Faceplate, 1" deep, for I2K and S2K	12
38621	Plastic Faceplate, 1/2" deep, for I2K and S2K	12
38619	Plain Box – Standard Pack	6



### APPROVALS & LISTINGS

Valves: NSF Standard 61, Section 9, ASME A112.18.1

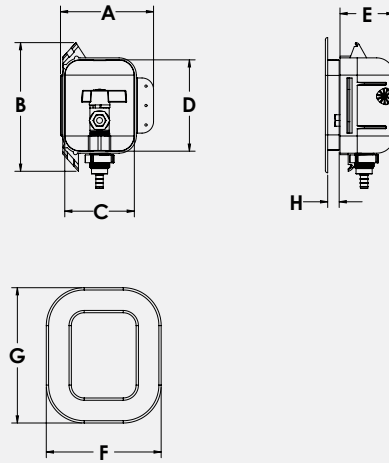

### DIMENSIONS

- A:** Box Width 4.05"
- B:** Box Height 5.60"
- C:** Box Opening Width 3.03"
- D:** Box Opening Height 3.98"
- E:** Box Depth 2.35"
- F:** Faceplate Width 5.00"
- G:** Faceplate Height 5.89"
- H:** Faceplate Depth 0.50"

STANDARD PACK: Faceplates are pre-assembled on box.

CONTRACTOR PACK: Faceplates are NOT pre-assembled on box (but come separately packed with the box).

## WASHING MACHINE OUTLET BOX

### SPECIFICATIONS

Oatey MODA™ Washing Machine Outlet Boxes shall be used in residential or commercial applications requiring supply valves and a waste drain recessed in the wall. The MODA™ washing machine assembly contains a valve box and a drain box, connected by inter-locking wing flanges that can be easily disassembled and re-assembled. The inter-locking wing flanges shall allow installation on a single stud, between two studs or on separate walls, without the need for additional components. Valves shall be a two-piece design, permitting field replacement, and shall be secured with a stainless steel retention clip. Valves are available with or without water hammer arrestors and shall be installed upright or inverted. The assembly shall include a removable quarter-turn plug for DWV testing, and shall include an emergency drain port for added protection from hose leaks.

PRODUCT NO.	DESCRIPTION	CTN. QTY.
<b>No Hammer</b>		
37601	MODA Washing Machine, Copper (Male), Standard	12
37603	MODA Washing Machine, F1807 PEX (Brass) Standard	12
37605	MODA Washing Machine, F1960 PEX (Brass) Standard	12
37602	MODA Washing Machine, CPVC (Male) Standard	12
37608	MODA Washing Machine, Push Connect Standard	12
37617	MODA Washing Machine, Copper (Male), Contractor	12
37619	MODA Washing Machine, F1807 PEX (Brass) Contractor	12
37621	MODA Washing Machine, F1960 PEX (Brass) Contractor	12
37618	MODA Washing Machine, CPVC (Male) Contractor	12
<b>Hammer</b>		
37609	MODA Washing Machine, Copper (Male), Standard	12
37611	MODA Washing Machine, F1807 PEX (Brass) Standard	12
37613	MODA Washing Machine, F1960 PEX (Brass) Standard	12
37610	MODA Washing Machine, CPVC (Male) Standard	12
37616	MODA Washing Machine, Push Connect Standard	12
37625	MODA Washing Machine, Copper (Male), Contractor	12
37627	MODA Washing Machine, F1807 PEX (Brass) Contractor	12
37629	MODA Washing Machine, F1960 PEX (Brass) Contractor	12
37626	MODA Washing Machine, CPVC (Male) Contractor	12



### ACCESSORY COMPONENTS INCLUDE:



Side Brackets



Sticker Cover for Debris Protection



Faceplate



Center Support



Test Plug



LocPin™ Stainless Steel Retention Clip



Blue & Red Clips

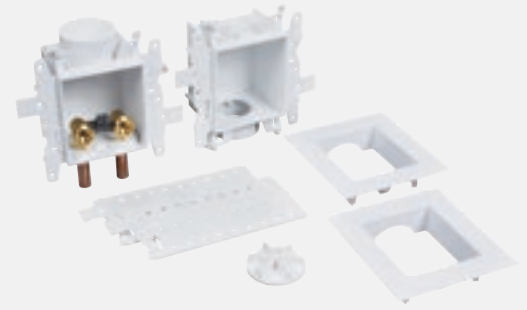

### APPROVALS & LISTINGS

**Valves:** ASME A12.18.1 / CSA B125.1 NSF / ANSI 61 & 372

**Water Hammer Arrestors:** ASSE 1010

**Boxes:** IAPMO-Listed

### FEATURES & MATERIALS

**Outlet Box & Brackets:** PVC

**Valve Body:** Forged Brass C37700

**Valve Retention Clip:** Stainless Steel

**Valve O-Rings:** NSF/FDA Approved EPDM (2)

### PERFORMANCE SPECIFICATIONS

**Temperature Rating (Valve):** 250° F / 121° C

**Max Testing Pressure (Valve):** 100 psi (Air) / 250 psi (Water)

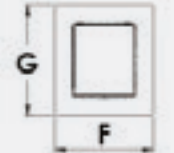
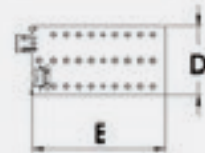
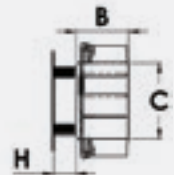
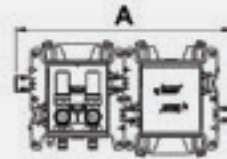

### DIMENSIONS

**A:** Assembled Width 14.13"

**B:** Box Depth 3.38"

**C:** Box Height 4.85"

**D:** Bracket Width 4.00"

**E:** Bracket Length 8.00"

**F:** Faceplate Width 6.00"

**G:** Faceplate Height 6.45"

**H:** Faceplate Depth 1.25"

All MODA boxes come with faceplates, side brackets and protective sticker. MODA Drain Boxes also come with a tool-free quarter-turn test plug.



## WASHING MACHINE OUTLET BOXES (SINGLE)

### SPECIFICATIONS

Oatey MODA™ Washing Machine Outlet Boxes shall be used in residential or commercial applications requiring supply valves and a waste drain recessed in the wall. The MODA™ washing machine assembly contains two supply valves and a drain connection, with inter-locking wing flanges on each side. Box shall be manufactured of PVC, allowing solvent welded joints to be prepared in accordance with ASTM D2855 for PVC drainage systems (without the use of specialty cements). The wing flanges shall allow installation on a single stud, or between two studs in combination with the included side brackets. No additional components shall be required for a between stud installation. Valves shall be a two-piece design, permitting field replacement, and shall be secured with a stainless steel retention clip. Valves are available with or without water hammer arrestors and shall be installed in an inverted configuration. The assembly shall include a knockout cap for DWV testing.

PRODUCT NO.	DESCRIPTION	CTN. QTY.
<b>No Hammer</b>		
37540	MODA Washing Machine, Copper (Male), Standard	12
37541	MODA Washing Machine, F1807 PEX (Brass) Standard	12
37543	MODA Washing Machine, F1960 PEX (Brass) Standard	12
37545	MODA Washing Machine, CPVC (Male) Standard	12
37546	MODA Washing Machine, Push Connect Standard	12
<b>Hammer</b>		
37550	MODA Washing Machine, Copper (Male), Standard	12
37551	MODA Washing Machine, F1807 PEX (Brass) Standard	12
37553	MODA Washing Machine, F1960 PEX (Brass) Standard	12
37555	MODA Washing Machine, CPVC (Male) Standard	12
37556	MODA Washing Machine, Push Connect Standard	12



### APPROVALS & LISTINGS

**Valves:** ASME A112.18.1 / CSA B125.1

**Water Hammer Arrestors:** ASSE 1010

**Boxes:** IAPMO-Listed, PS-54

### FEATURES & MATERIALS

**Outlet Box & Brackets:** PVC

**Valve Body:** Forged Brass C37700

**Valve Retention Clip:** Stainless Steel

**Valve O-Rings:** NSF/FDA Approved EPDM (2)

### PERFORMANCE SPECIFICATIONS

**Temperature Rating (Valve):** 250° F / 121° C

**Max Testing Pressure (Valve):** 100 psi (Air) / 250 psi (Water)



### ACCESSORY COMPONENTS INCLUDE:



Side Brackets



Faceplate



Sticker Cover for Debris Protection



LocPin™  
Stainless Steel  
Retention Clip



Blue & Red Clips

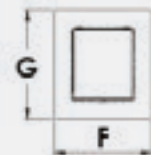
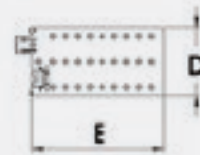
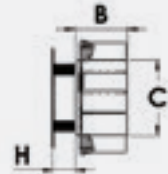
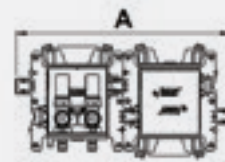

### DIMENSIONS

**A:** Box Width 8.00"

**B:** Box Depth 3.38"

**C:** Box Height 4.85"

**D:** Bracket Width 4.00"

**E:** Bracket Length 8.00"

**F:** Faceplate Width 6.00"

**G:** Faceplate Height 6.45"

**H:** Faceplate Depth 1.25"

**ICE MAKER OUTLET BOX**

**SPECIFICATIONS**

Oatey MODA™ Ice Maker Supply Boxes shall be used in residential or commercial applications requiring a supply valve recessed in the wall. The MODA™ ice maker box assembly contains a 1/4" OD compression valve pre-installed in a PVC box, with inter-locking wing flanges on each side. The wing flanges shall allow installation on a single stud, or between two studs using the included side brackets. No additional components shall be required for a between stud installation. Valves shall be a two-piece design, permitting field replacement, and shall be secured with a stainless steel retention clip. Valves are available with or without water hammer arrestors and shall be installed upright or inverted. The assembly shall include an emergency drain port for protection from tubing leaks.

PRODUCT NO.	DESCRIPTION	CTN. QTY.
<b>No Hammer Arrestors</b>		
37679	MODA Ice Maker, Copper (Male), Standard	12
37681	MODA Ice Maker, F1807 PEX (Brass), Standard	12
37683	MODA Ice Maker, F1960 PEX (Brass), Standard	12
37680	MODA Ice Maker, CPVC (Male), Standard	12
37686	MODA Ice Maker, Push Connect, Standard	12
37695	MODA Ice Maker, Copper (Male), Contractor	12
37697	MODA Ice Maker, F1807 PEX (Brass), Contractor	12
37699	MODA Ice Maker, F1960 PEX (Brass), Contractor	12
37696	MODA Ice Maker, CPVC (Male), Contractor	12
<b>Hammer Arrestors</b>		
37687	MODA Ice Maker, Copper (Male), Standard	12
37689	MODA Ice Maker, F1807 PEX (Brass), Standard	12
37691	MODA Ice Maker, F1960 PEX (Brass), Standard	12
37688	MODA Ice Maker, CPVC (Male), Standard	12
37694	MODA Ice Maker, Push Connect, Standard	12
37703	MODA Ice Maker, Copper (Male), Contractor	12
37705	MODA Ice Maker, F1807 PEX (Brass), Contractor	12
37707	MODA Ice Maker, F1960 PEX (Brass), Contractor	12
37704	MODA Ice Maker, CPVC (Male), Contractor	12



**ACCESSORY COMPONENTS INCLUDE:**



Side Brackets



Faceplate



Sticker Cover for Debris Protection



LocPin™  
Stainless Steel Retention Clip

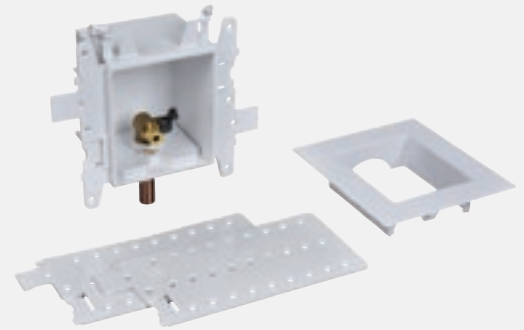

**APPROVALS & LISTINGS**

**Valves:** ASME A112.18.1 / CSA B125.1 NSF / ANSI 61 & 372

**Water Hammer Arrestors:** ASSE 1010

**Boxes:** IAPMO-Listed, PS-54

**FEATURES & MATERIALS**

**Outlet Box & Brackets:** PVC

**Valve Body:** Forged Brass C46500 No Lead

**Valve Retention Clip:** Stainless Steel

**Valve O-Rings:** NSF Approved EPDM (2)

**PERFORMANCE SPECIFICATIONS**

**Temperature Rating (Valve):** 250°F / 121°C

**Max Testing Pressure (Valve):** 100 psi (Air) / 250 psi (Water)

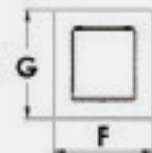
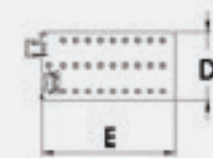
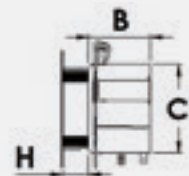
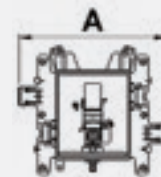

**DIMENSIONS**

**A:** Box Width 8.00"

**B:** Box Depth 3.38"

**C:** Box Height 4.85"

**D:** Bracket Width 4.00"

**E:** Bracket Length 8.00"

**F:** Faceplate Width 6.00"

**G:** Faceplate Height 6.45"

**H:** Faceplate Depth 1.25"

All MODA boxes come with faceplates, side brackets and protective sticker. MODA Drain Boxes also come with a tool-free quarter-turn test plug.



## TOILET OR DISHWASHER SUPPLY BOXES

### SPECIFICATIONS

Oatey MODA™ Toilet Supply Boxes shall be used in residential or commercial applications requiring a supply valve recessed in the wall. The MODA™ toilet box assembly contains a 3/8" OD compression valve pre-installed in a PVC box, with inter-locking wing flanges on each side. The wing flanges shall allow installation on a single stud, or between two studs using the included side brackets. No additional components shall be required for a between stud installation. Valves shall be a two-piece design, permitting field replacement, and shall be secured with a stainless steel retention clip. Valves are available with or without water hammer arrestors and shall be installed upright or inverted. The assembly shall include an emergency drain port for protection from supply hose leaks.

PRODUCT NO.	DESCRIPTION	CTN. QTY.
<b>No Hammer</b>		
37897	MODA Toilet / Dishwasher, Copper (Male), Standard	12
37899	MODA Toilet / Dishwasher, F1807 PEX (Brass), Standard	12
37901	MODA Toilet / Dishwasher, F1960 PEX (Brass), Standard	12
37898	MODA Toilet / Dishwasher, CPVC (Male), Standard	12
37904	MODA Toilet / Dishwasher, Push Connect, Standard	12
<b>Hammer</b>		
37905	MODA Toilet / Dishwasher, Copper (Male), Standard	12
37907	MODA Toilet / Dishwasher, F1807 PEX (Brass), Standard	12
37909	MODA Toilet / Dishwasher, F1960 PEX (Brass), Standard	12
37906	MODA Toilet / Dishwasher, CPVC (Male), Standard	12
37912	MODA Toilet / Dishwasher, Push Connect, Standard	12

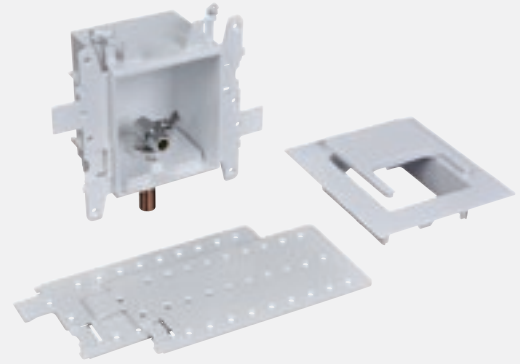

### APPROVALS & LISTINGS

**Valves:** ASME A112.18.1 / CSA B125.1 NSF / ANSI 61 & 372

**Water Hammer Arrestors:** ASSE 1010

**Boxes:** IAPMO-Listed, PS-54

### FEATURES & MATERIALS

**Outlet Box & Brackets:** PVC

**Valve Body:** Forged Brass C46500 No Lead (Chrome Plated)

**Valve Retention Clip:** Stainless Steel

**Valve O-Rings:** NSF Approved EPDM (2)

### PERFORMANCE SPECIFICATIONS

**Temperature Rating (Valve):** 250° F / 121° C

**Max Testing Pressure (Valve):** 100 psi (Air) / 250 psi (Water)



### ACCESSORY COMPONENTS INCLUDE:



Side Brackets



Faceplate



Sticker Cover for Debris Protection



LocPin™  
Stainless Steel  
Retention Clip



Faceplate Insert

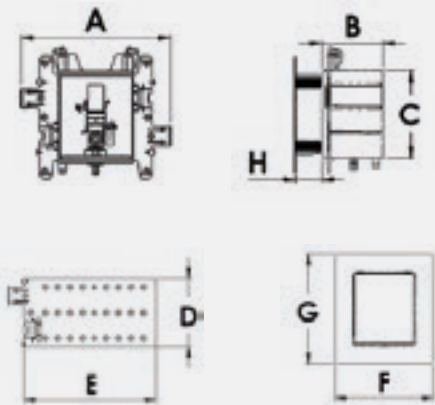

### DIMENSIONS

**A:** Box Width 8.00"

**B:** Box Depth 3.38"

**C:** Box Height 4.85"

**D:** Bracket Width 4.00"

**E:** Bracket Length 8.00"

**F:** Faceplate Width 6.00"

**G:** Faceplate Height 6.45"

**H:** Faceplate Depth 1.25"

All MODA boxes come with faceplates, side brackets and protective sticker.  
MODA Drain Boxes also come with a tool-free quarter-turn test plug.



## LAVATORY SUPPLY BOXES – TWO VALVE BOX

### SPECIFICATIONS

Oatey MODA™ Lavatory Supply Boxes shall be used in residential or commercial applications requiring a supply valve recessed in the wall. The MODA™ lavatory assembly contains two 3/8" OD compression valves pre-installed in a PVC box, connected by inter-locking wing flanges that can be easily disassembled and re-assembled. The wing flanges shall allow installation on a single stud, or between two studs using the included side brackets. No additional components shall be required for a between stud installation. Valves shall be a two-piece design, permitting field replacement, and shall be secured with a stainless steel retention clip. Valves are available with or without water hammer arrestors and shall be installed upright or inverted. The assembly shall include an emergency drain port for protection from supply hose leaks.

PRODUCT NO.	DESCRIPTION	CTN. QTY.
<b>No Hammer Arrestors</b>		
37741	MODA Lavatory, Copper (Male), Standard	12
37743	MODA Lavatory, F1807 PEX (Brass), Standard	12
37745	MODA Lavatory, F1960 PEX (Brass), Standard	12
37742	MODA Lavatory, CPVC (Male), Standard	12
37748	MODA Lavatory, Push Connect, Standard	12
37757	MODA Lavatory, Copper (Male), Contractor	12
37759	MODA Lavatory, F1807 PEX (Brass), Contractor	12
37761	MODA Lavatory, F1960 PEX (Brass), Contractor	12
37758	MODA Lavatory, CPVC (Male), Contractor	12
<b>Hammer Arrestors</b>		
37749	MODA Lavatory, Copper (Male), Standard	12
37751	MODA Lavatory, F1807 PEX (Brass), Standard	12
37753	MODA Lavatory, F1960 PEX (Brass), Standard	12
37750	MODA Lavatory, CPVC (Male), Standard	12
37756	MODA Lavatory, Push Connect, Standard	12
37765	MODA Lavatory, Copper (Male), Contractor	12
37767	MODA Lavatory, F1807 PEX (Brass), Contractor	12
37769	MODA Lavatory, F1960 PEX (Brass), Contractor	12
37766	MODA Lavatory, CPVC (Male), Contractor	12



### ACCESSORY COMPONENTS INCLUDE:



Side Brackets



Faceplate



Sticker Cover for Debris Protection



LocPin™  
Stainless Steel  
Retention Clip



Faceplate Insert



Blue & Red Clips

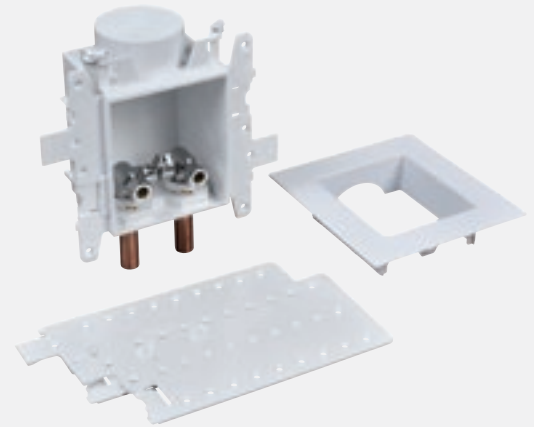

### APPROVALS & LISTINGS

**Valves:** ASME A112.18.1 / CSA B125.1 NSF / ANSI 61 & 372

**Water Hammer Arrestors:** ASSE 1010

**Boxes:** IAPMO-Listed, PS-54

### FEATURES & MATERIALS

**Outlet Box & Brackets:** PVC

**Valve Body:** Forged Brass C46500 No Lead (Chrome Plated)

**Valve Retention Clip:** Stainless Steel

**Valve O-Rings:** NSF/FDA Approved EPDM (2)

### PERFORMANCE SPECIFICATIONS

**Temperature Rating (Valve):** 250° F / 121° C

**Max Testing Pressure (Valve):** 100 psi (Air) / 250 psi (Water)

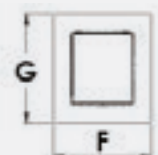
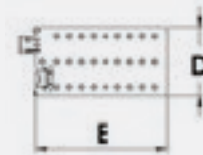
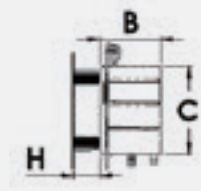
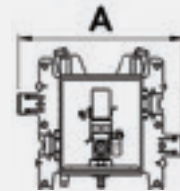

### DIMENSIONS

**A:** Box Width 8.00"

**B:** Box Depth 3.38"

**C:** Box Height 4.85"

**D:** Bracket Width 4.00"

**E:** Bracket Length 8.00"

**F:** Faceplate Width 6.00"

**G:** Faceplate Height 6.45"

**H:** Faceplate Depth 1.25"

All MODA boxes come with faceplates, side brackets and protective sticker. MODA Drain Boxes also come with a tool-free quarter-turn test plug.



## KITCHEN OUTLET BOX – TWO VALVE BOX + ONE VALVE BOX

### SPECIFICATIONS

Oatey MODA™ Kitchen Outlet Boxes shall be used in residential or commercial applications requiring a supply valve recessed in the wall. The MODA™ lavatory assembly contains three 3/8" OD compression valves pre-installed in a two PVC boxes, connected by inter-locking wing flanges that can be easily disassembled and re-assembled. The inter-locking wing flanges shall allow installation on a single stud, between two studs or on separate walls, without the need for additional components. No additional components shall be required for a between stud installation. Valves shall be a two-piece design, permitting field replacement, and shall be secured with a stainless steel retention clip. Valves are available with or without water hammer arrestors and shall be installed upright or inverted. The assembly shall include a include an emergency drain port for protection from tubing leaks.

PRODUCT NO.	DESCRIPTION	CTN. QTY.
<b>No Hammer Arrestors</b>		
37819	MODA Kitchen, Copper (Male), Standard	12
37821	MODA Kitchen, F1807 PEX (Brass), Standard	12
37823	MODA Kitchen, F1960 PEX (Brass), Standard	12
37820	MODA Kitchen, CPVC (Male), Standard	12
37826	MODA Kitchen, Push Connect, Standard	12
<b>Hammer Arrestors</b>		
37827	MODA Kitchen, Copper (Male), Standard	12
37829	MODA Kitchen, F1807 PEX (Brass), Standard	12
37831	MODA Kitchen, F1960 PEX (Brass), Standard	12
37828	MODA Kitchen, CPVC (Male), Standard	12
37834	MODA Kitchen, Push Connect, Standard	12



### ACCESSORY COMPONENTS INCLUDE:



Side Brackets



Faceplate



Sticker Cover for Debris Protection



Center Support



LocPin™  
Stainless Steel  
Retention Clip



Blue & Red Clips

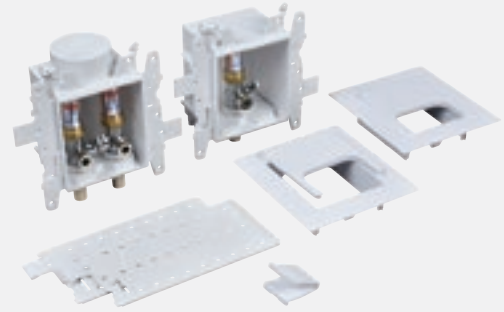

### APPROVALS & LISTINGS

**Valves:** ASME A112.18.1 / CSA B125.1 NSF / ANSI 61 & 372

**Water Hammer Arrestors:** ASSE 1010

**Boxes:** IAPMO-Listed

### FEATURES & MATERIALS

**Outlet Box & Brackets:** PVC

**Valve Body:** Forged Brass C46500 No Lead (Chrome Plated)

**Valve Retention Clip:** Stainless Steel

**Valve O-Rings:** NSF/FDA Approved EPDM (2)

### PERFORMANCE SPECIFICATIONS

**Temperature Rating (Valve):** 250° F / 121° C

**Max Testing Pressure (Valve):** 100 psi (Air) / 250 psi (Water)

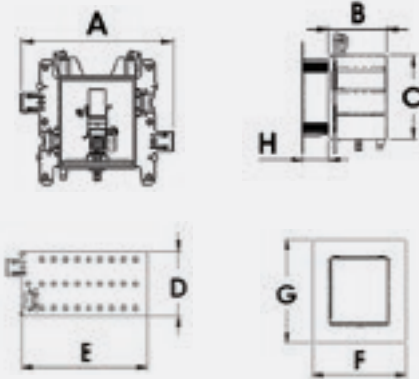

### DIMENSIONS

**A:** Assembled Width 14.13"

**B:** Box Depth 3.38"

**C:** Box Height 4.85"

**D:** Bracket Width 4.00"

**E:** Bracket Length 8.00"

**F:** Faceplate Width 6.00"

**G:** Faceplate Height 6.45"

**H:** Faceplate Depth 1.25"

All MODA boxes come with faceplates, side brackets and protective sticker. MODA Drain Boxes also come with a tool-free quarter-turn test plug.

**SECONDARY DRAIN KIT**

**SPECIFICATIONS**

Oatey MODA™ Secondary Drain Kit Outlet Boxes shall be used in residential or commercial applications requiring drain line access recessed in the wall. MODA™ secondary drain kits contain a quarter-turn drainage funnel, and a pre-installed inlet adapter for connection to condensate, water softener or other auxiliary drain lines. When installed, the drainage funnel provides a 1" air gap to the drain, while permitting the use of a washing machine hose in the same drain line. The inlet adapter shall have with a male test plug, secured with a stainless steel retention ring. The drain connection shall include a removable quarter-turn plug for DWV testing. Box shall be manufactured of PVC, allowing solvent welded joints to be prepared in accordance with ASTM D2855 for PVC drainage systems (without the use of specialty cements). The outlet boxes shall also include inter-locking wing flanges on each side. The outlet box wing flanges shall allow installation on a single stud, or between two studs using the included side brackets. No additional components shall be required for a between stud installation.

PRODUCT NO.	SIZE	DESCRIPTION	CTN. QTY.
37557	1/2"	MODA Secondary Drain Kit, Copper (Male), Standard	12
37985	1/2"	MODA Secondary Drain Kit, F1807 PEX (Brass), Standard	12
37986	1/2"	MODA Secondary Drain Kit, F1960 PEX (Brass), Standard	12
37558	1/2"	MODA Secondary Drain Kit, CPVC (Male), Standard	12
37559	3/4"	MODA Secondary Drain Kit Copper (Male), Standard	12
37987	3/4"	MODA Secondary Drain Kit, F1807 PEX (Brass), Standard	12
37988	3/4"	MODA Secondary Drain Kit, F1960 PEX (Brass), Standard	12

\*Designed to be paired with single washing machine box



**ACCESSORY COMPONENTS INCLUDE:**



Side Brackets



Faceplate



Sticker Cover for Debris Protection



DWW Test Plug



Quarter-Turn Drainage Funnel



Funnel Top with Clip



**APPROVALS & LISTINGS**

**Boxes:** IAPMO-Listed

**FEATURES & MATERIALS**

**Outlet Box, Funnel & Brackets:** PVC

**Plug Retention Ring:** Stainless Steel

**PERFORMANCE SPECIFICATIONS**

**Temperature Range:** 250° F / 71° C

**Maximum Flow Rate:** 8.5 Gallons per Minute

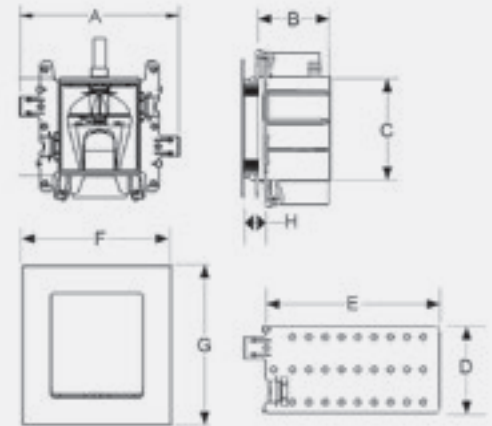

**DIMENSIONS**

**A:** Box Width 8.00"

**B:** Box Depth 3.38"

**C:** Box Height 4.85"

**D:** Bracket Width 4.00"

**E:** Bracket Length 8.00"

**F:** Faceplate Width 6.00"

**G:** Faceplate Height 6.45"

**H:** Faceplate Depth 1.25"

All MODA boxes come with faceplates, side brackets and protective sticker. MODA Drain Boxes also come with a tool-free quarter turn test plug.



## SURE-VENT® AIR ADMITTANCE VALVE BOXES

### SPECIFICATIONS

The purpose of an Air Admittance Valve is to provide a method of allowing air to enter the plumbing drainage system without the use of a vent extended to open air and to prevent sewer gases from escaping into a building. An Air Admittance Valve is a one way valve designed to allow air to enter the plumbing drainage system when negative pressures develop in the piping system. The device shall close by gravity and seal the vent terminal at zero differential pressure (no flow conditions) and under positive internal pressures.

PRODUCT NO.	DESCRIPTION	CTN. QTY.
37981	MODA, Sure-Vent, 160Branch/24 Stack DFU, Standard Pack	12

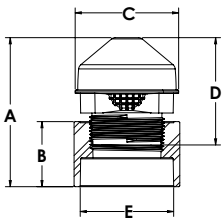

#### 20 BRANCH, 8 STACK DIMENSIONS

- A:** Overall Height 3.59"      **D:** Height D 2.54"
- B:** Adapter Height 1.65"      **E:** Adapter ID 2" Hub
- C:** Diameter 2.62"

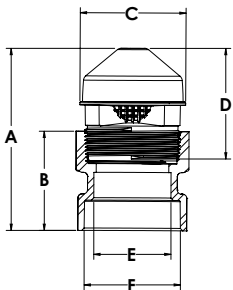

#### 160 BRANCH, 24 STACK DIMENSIONS

- A:** Overall Height 4.53"      **D:** Height D 2.79"
- B:** Adapter Height 2.46"      **E:** Adapter ID 1.5" Hub
- C:** Diameter 2.62"      **F:** Adapter OD 2" Hub

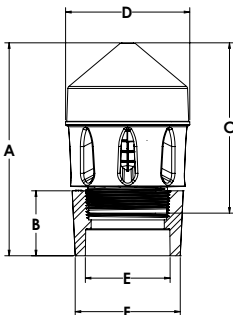

#### 160 BRANCH, 72 STACK DIMENSIONS

- A:** Overall Height 6.00"      **D:** Height Without Adapter 3.50"
- B:** Adapter Height 1.83"      **E:** Adapter ID 2" Hub
- C:** Diameter 4.80"      **F:** Adapter OD 3" Pipe

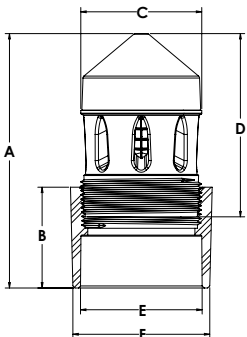

#### 160 BRANCH, 500 STACK DIMENSIONS

- A:** Overall Height 7.23"      **D:** Height Without Adapter 5.23"
- B:** Adapter Height 2.92"      **E:** Adapter ID 3" Hub
- C:** Diameter 3.50"      **F:** Adapter OD 4" Pipe



### APPROVALS & LISTINGS

ASSE 1050 & 1051  
 ICC ESR-1664  
 NSF Standard 14  
 IAPMO – Classified Mark  
 ASTM D 2665/D 2661  
 International Plumbing Code (IPC) 2003  
 International Residential Code (IRC) 2003

### FEATURES & MATERIALS

**Tension Membrane:** Silicone  
**Sweet Spot™:** Sweet Spot™ technology opens at -0.01 psi and seals at 0 psi and above  
**Screening:** Screening on air inlets to guard the seal  
**Grip:** Protective sleeve provides grip for installation and keeps valve free from debris  
**Tested:** 100% functionally tested at ¼" H<sub>2</sub>O and 30" H<sub>2</sub>O ensuring trouble free performance  
**Warranty:** Limited Lifetime Warranty



## PLAIN BOXES

### SPECIFICATIONS

The Moda Supply Box System is designed to meet the needs of plumbing contractors for washing machine, ice maker, lavatory, toilet, dishwasher and Sure-Vent® Air Admittance Valve applications. A universal single box platform provides maximum versatility, installation simplicity and rugged reliability. MODA Supply Box System is the ultimate solution for speed and flexibility.

PRODUCT NO.	DESCRIPTION	CTN. QTY.
37971	MODA Plain Box, 1 Valve Port, Standard	12
37972	MODA Plain Box, 2 Valve Port, Standard	12
37970	MODA Plain Box, Standard Drain, Standard	12
37450 	MODA Plain Box, Standard Drain	12
37973	MODA Plain Box, Drain + Aux Port, Standard	12
37974	MODA Plain Box, Drain + 2 Aux Port, Standard	12

 Denotes Fire-Rated

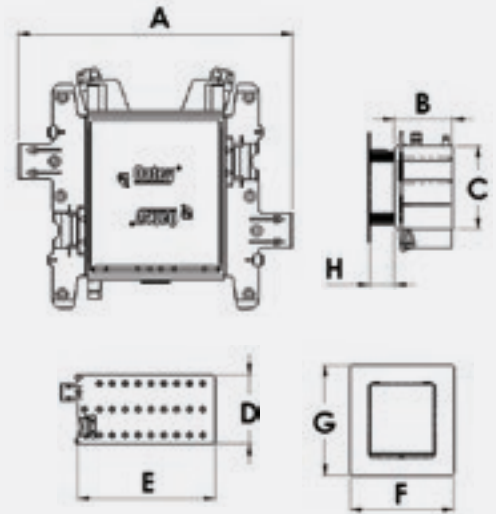
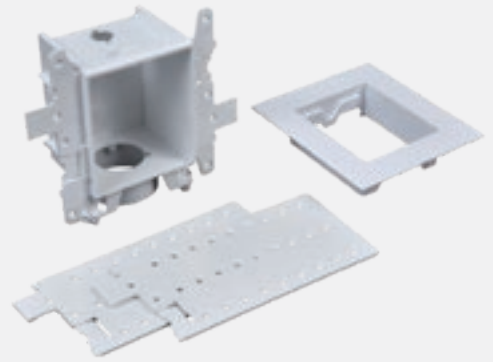

### DIMENSIONS

**A:** Box Width 8.00"

**B:** Box Depth 3.38"

**C:** Box Height 4.85"

**D:** Bracket Width 4.00"

**E:** Bracket Length 8.00"

**F:** Faceplate Width 6.00"

**G:** Faceplate Height 6.45"

**H:** Faceplate Depth 1.25"



## GAS SUPPLY BOX AND BOX EXTENSION

### SPECIFICATIONS

Oatey MODA™ Gas Supply Boxes shall be used in gas supply systems for residential or commercial applications. Boxes shall allow for mounting direct-to-stud or between studs with supply line from top or bottom. Valves shall be available with yellow handle, with or without brass shank, and plastic brackets for between stud configuration. Outlet shall be 1/2" or 3/4" with 1/4 turn valve.

PRODUCT NO.	DESCRIPTION	CTN. QTY.
<b>Gas Supply</b>		
37560	MODA Gas Supply Box, Brass, 1/2 NPT Valve	1
37561	MODA Gas Supply Box, Brass, 3/4 NPT Valve	1
37562	MODA Gas Supply Box, 1/2 NPT Valve, Test Plug, ADAP, Locknut Kit	1
37563	MODA Gas Supply Box, 3/4 NPT Valve, Test Plug, ADAP, Locknut Kit	1
37564	MODA Gas Supply Box, Plain Box, No Valves	1

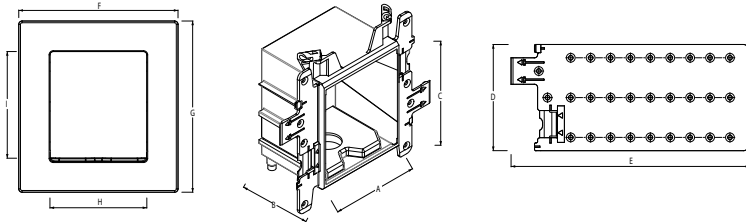

### DIMENSIONS

- A:** Box Width 4.00"
- B:** Box Depth 3.38"
- C:** Box Height 4.85"
- D:** Bracket Width 4.00"
- E:** Bracket Length 8.00"
- F:** Faceplate Width 6.00"
- G:** Faceplate Height 6.45"
- H:** Faceplate Opening Width 3.62"
- I:** Faceplate Opening Height 4.12"
- J:** Faceplate Depth 1.25"

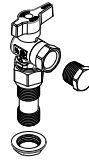

### APPROVALS & LISTINGS

Valves: ANSI Z21.15/CSA9.1-2009

### FEATURES & MATERIALS

- Supply Box:** PVC
- Faceplate:** HIPS
- Bracket:** PVC
- Valve Body:** Brass
- Valve Handle:** Aluminum Alloy
- Locknut:** Zinc Alloy
- Adapter:** Brass
- Test Plug:** Brass
- Sizes (Outlets):** 1/2" & 3/4"

### GAS TYPES

- Natural
- Propane

### PERFORMANCE SPECIFICATIONS

- Max Working Pressure:** 1/2 psig
- Max Working Pressure:** 10 psi

### SPECIFICATIONS

Oatey MODA™ Box Extensions shall be used where supply boxes are installed in thicker wall applications. The extension shall extend the supply box face 1" and accommodate additional layers of drywall. The extension shall fit to any MODA box, supply or drain, and is stackable if additional extensions are required.

PRODUCT NO.	DESCRIPTION	CTN. QTY.
<b>Box Extension</b>		
37565	MODA Box Extension	6

### DIMENSIONS

- A:** Height 4.875"
- B:** Width 4"
- C:** Depth 0.94"

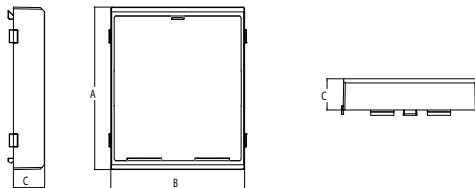

### FEATURES & MATERIALS

- Frame Extension:** PVC

### PERFORMANCE SPECIFICATIONS

- Melting Point:** 200°F
- Working Temperature:** 150°F

**ACCESSORIES + VALVES**

**SPECIFICATIONS**

The Moda Supply Box System is designed to meet the needs of plumbing contractors for washing machine, ice maker, lavatory, toilet, dishwasher and Sure-Vent® Air Admittance Valve applications. A universal single box platform provides maximum versatility, installation simplicity & rugged reliability. The MODA System is the ultimate solution for speed & flexibility.

- One universal faceplate is compatible with all MODA boxes.
- Interlocking wing flanges accommodate on-stud, straddle-stud and 3-box installation.
- Tough PVC construction and no transition cement needed when solvent welding PVC.
- 2 piece valve with LocPin™ makes repairing valves easy without damaging drywall.

PRODUCT NO.	DESCRIPTION	CTN. QTY.
<b>MODA™ Accessories</b>		
37531	MODA Faceplate	12
37532	MODA Faceplate Insert - Solid	12
37533	MODA Faceplate Insert - Semi-Cover	12
37534	MODA Faceplate Insert - Louvered	12
37535	MODA Plastic Bracket	12
37453	MODA Large Metal Bracket	6
37454	MODA L - Bracket	12
35971	MODA Secondary Drain, Condensate Test Plug	6
37565	MODA Box Extension	6
38576	MODA DWV Quarter Turn Test Plug	12
37536	MODA Secondary Drainage Funnel	12
37537	MODA Sure-Vent Adapter	12
37538	MODA Valve Clip Cover	12
37539	MODA Center Support	12
37529	MODA Debris Cover Sticker	12
37530	Telescoping Steel Bracket	12
<b>MODA™ Valves</b>		
37500	MODA Valve Top + Clip, WMOB, NoHam, Gray Handle, Cold	1
37501	MODA Valve Top + Clip, WMOB, NoHam, Gray Handle, Hot	1
37502	MODA Valve Top + Clip, WMOB, Ham, Gray Handle, Cold	1
37503	MODA Valve Top + Clip, WMOB, Ham, Gray Handle, Hot	1
37504	MODA Valve Top + Clip, Utility, NoHam, Gray Handle, Cold	1
37505	MODA Valve Top + Clip, Utility, NoHam, Gray Handle, Hot	1
37506	MODA Valve Top + Clip, Utility, Ham, Gray Handle, Cold	1
37507	MODA Valve Top + Clip, Utility, Ham, Gray Handle, Hot	1
37508	MODA Valve Top + Clip, IMOB, No Hammer	1
37509	MODA Valve Top + Clip, IMOB, Hammer	1
37510	MODA 1/2" Copper Tailpiece Adapter Male	1
37511	MODA 1/2" Brass F1807 Tailpiece Adapter	1
37512	MODA 1/2" Brass F1960 Tailpiece Adapter	1
37515	MODA 1/2" CPVC Tailpiece Adapter Male	1
37516	MODA 3/4" Copper Tailpiece Adapter Male	1
37517	MODA 3/4" Brass F1807 Tailpiece Adapter	1
37518	MODA 3/4" Brass F1960 Tailpiece Adapter	1
38294	Hot/Cold Valve Temperature Indicator Clips (12 Red, 12 Blue)	24



All MODA boxes come with faceplates, side brackets and protective sticker. MODA Drain Boxes also come with a tool-free quarter-turn test plug.



## FIRE-RATED WASHING MACHINE OUTLET BOXES

### SPECIFICATIONS

Oatey MODA™ Fire-Rated Washing Machine Outlet Boxes shall be used in residential or commercial applications requiring supply valves and a waste drain recessed in the wall. The MODA™ fire-rated washing machine assembly contains a valve box and a drain box, with interlocking flanges on each side. Box shall be manufactured of PVC, allowing solvent welded joints to be prepared in accordance with ASTM D2855 for PVC drainage systems (without the use of specialty cements). The wing flanges in conjunction with the metal bracket allow for direct to stud installation. L-shape brackets are included for support based on wall rating (see instruction sheet). All double boxes can be interlocked for direct installation to steel and wood studs. They can also be installed independently on separate studs. Valves shall be a two-piece design, permitting field replacement, and shall be secured with a stainless steel retention clip. Valves are available with or without water hammer arrestors and shall be installed upright. The assembly shall include a removable quarter-turn knock out plug for DWV testing, and shall include an emergency drain port for added protection from valve leaks.

PRODUCT NO.	DESCRIPTION	CTN. QTY.
<b>No Hammer</b>		
37350	WMOB, Copper, NoHam, Single Pack	1
37351	WMOB, F1807-Brass, NoHam, Single Pack	1
37353	WMOB, F1960-Brass, NoHam, Single Pack	1
37355	WMOB, CPVC, NoHam, Single Pack	1
37356	WMOB, Push Cnc, NoHam, Single Pack	1
<b>Hammer</b>		
37357	WMOB, Copper, Ham, Single Pack	1
37358	WMOB, F1807-Brass, Ham, Single Pack	1
37360	WMOB, F1960-Brass, Ham, Single Pack	1
37362	WMOB, CPVC, Ham, Single Pack	1
37363	WMOB, Push Cnc, Ham, Single Pack	1



### ACCESSORY COMPONENTS INCLUDE:



Faceplates (2)



Test Plug



Sticker Cover for  
Debris Protection



Intumescent Pad  
(Pre-Installed)



Metal Brackets (2)



L-shape Brackets (4)



### APPROVALS & LISTINGS

**Valves:** ASME A112.18.1 / CSA B125.1 NSF / ANSI 61 & 372

**Boxes:** IAPMO-Listed, PS-54

**Listed with Massachusetts Board of Plumbing**

**Listed by Warnock Hersey to meet: ASTM E814**

**2-Hour Design:** F-Rating: 2 Hour, T-Rating: 1-1/4 Hour

**1-Hour Design:** F-Rating: 1 Hour, T-Rating: 3/4 Hour

**CAN/ULC S115**

**2-Hour Design:** FH Rating: 2 Hour, FTH Rating: 1-1/4 Hour

**1-Hour Design:** FH Rating: 1 Hour, FTH Rating: 3/4 Hour

### FEATURES & MATERIALS

**Outlet Box & Brackets:** PVC

**Valve Body:** Forged Brass C37700

**Valve Retention Clip:** Stainless Steel

**Valve O-Rings:** NSF Approved EPDM (2)

**Metal Bracket and L-shape Brackets:** 16 Gauge Galvanized Steel

**Arrestor Body:** Copper (Type L)

**Piston:** Polypropylene with two NBR O-rings

**Piston Lubrication:** Dow Corning Molykote 111

### PERFORMANCE SPECIFICATIONS

**Temperature Rating (Valve):** 250° F/121° C

**Max Testing Pressure (Valve):** 100 psi (Air) / 250 psi (Water)

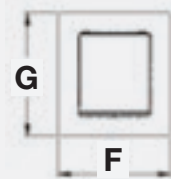
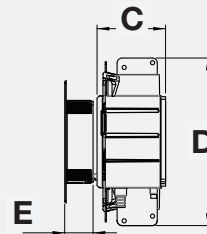
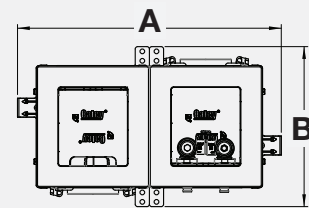

### DIMENSIONS

**A:** Assembled Width 13.96"

**B:** Box Height 8.46"

**C:** Box Depth 3.63"

**D:** Metal Bracket Height 8.87"

**E:** Faceplate Depth 1.25"

**F:** Faceplate Width 6.00"

**G:** Faceplate Height 6.45"



**Oatey****MODA™**  
MODULAR SUPPLY BOX SYSTEM**FIRE-RATED TOILET SUPPLY  
OUTLET BOX****SPECIFICATIONS**

Oatey MODA™ Fire-Rated Toilet Supply Boxes shall be used in residential or commercial applications requiring a supply valve recessed in the wall. The MODA™ fire-rated toilet box assembly contains a 3/8" OD compression valve pre-installed in a PVC box, with inter-locking wing flanges on each side. The wing flanges shall allow installation on a single stud in conjunction with the metal bracket. L-shape brackets are included for support based on wall rating ( see instruction sheet). Valves shall be a two-piece design, permitting field replacement, and shall be secured with a stainless steel retention clip. Valves are available with or without water hammer arrestors and shall be installed upright. The assembly shall include an emergency drain port for protection from supply hose leaks.

PRODUCT NO.	DESCRIPTION	CTN. QTY.
<b>No Hammer</b>		
37420	TLT, Copper, NoHam, Single Pack	1
37421	TLT, F1807-Brass, NoHam, Single Pack	1
37423	TLT, F1960-Brass, NoHam, Single Pack	1
37425	TLT, CPVC, NoHam, Single Pack	1
37426	TLT, Push CNC, NoHam, Single Pack	1
<b>Hammer</b>		
37427	TLT, Copper, Ham, Single Pack	1
37428	TLT, F1807-Brass, Ham, Single Pack	1
37430	TLT, F1960-Brass, Ham, Single Pack	1
37432	TLT, CPVC, Ham, Single Pack	1
37433	TLT, Push CNC, Ham, Single Pack	1

**ACCESSORY COMPONENTS INCLUDE:**

Faceplates

Intumescent Pad  
(Pre-Installed)Sticker Cover for  
Debris Protection

Metal Brackets (1)

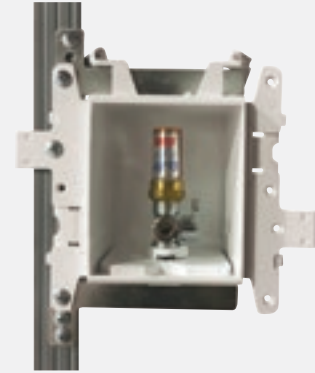

L-shape Brackets (2)

**APPROVALS & LISTINGS**

**Valves:** ASME A112.18.1 / CSA B125.1 NSF / ANSI 61 & 372

**Boxes:** IAPMO-Listed, PS-54

**Listed with Massachusetts Board of Plumbing**

**Listed by Warnock Hersey to meet: ASTM E814**

**2-Hour Design:** F-Rating: 2 Hour, T-Rating: 1-1/4 Hour

**1-Hour Design:** F-Rating: 1 Hour, T-Rating: 3/4 Hour

**CAN/ULC S115**

**2-Hour Design:** FH Rating: 2 Hour, FTH Rating: 1-1/4 Hour

**1-Hour Design:** FH Rating: 1 Hour, FTH Rating: 3/4 Hour

**FEATURES & MATERIALS**

**Outlet Box & Brackets:** PVC

**Valve Body:** Forged Brass C46500 No Lead

**Valve Retention Clip:** Stainless Steel

**Valve O-Rings:** NSF Approved EPDM (2)

**Metal Bracket and L-shape Brackets:** 16 Gauge

Galvanized Steel

**Arrestor Body:** Copper (Type L)

**Piston:** Polypropylene with two NBR O-rings

**Piston Lubrication:** Dow Corning Molykote 111

**PERFORMANCE SPECIFICATIONS**

**Temperature Rating (Valve):** 250° F/121° C

**Max Testing Pressure (Valve):** 100 psi (Air) / 250 psi (Water)

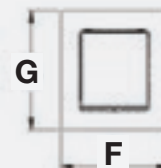
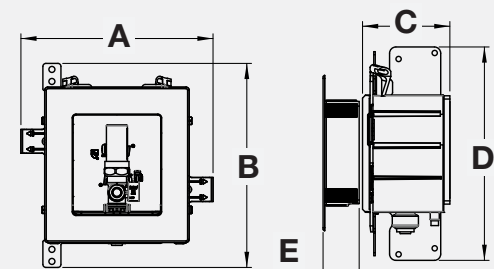
**DIMENSIONS**

**A:** Box Width 7.98"

**B:** Box Height 8.46"

**C:** Box Depth 3.63"

**D:** Metal Bracket Height 8.87"

**E:** Faceplate Depth 1.25"

**F:** Faceplate Width 6.00"

**G:** Faceplate Height 6.45"



## FIRE-RATED SURE-VENT® AIR ADMITTANCE VALVE BOX

### SPECIFICATIONS

Oatey Sure-Vent® Air Admittance Valves provide a method of allowing air to enter the plumbing drainage system without the use of a vent extended to open air and to prevent sewer gases from escaping into a building. An air admittance valve is a one way valve designed to allow air to enter the plumbing drainage system when negative pressures develop in the piping system. The device shall close by gravity and seal the vent terminal at zero differential pressure (no flow conditions) and under positive internal pressures. Valves shall be 100% functionally tested at ¼" H<sub>2</sub>O and 30" H<sub>2</sub>O water column. The valves shall utilize a soft-centered, silicone membrane with Sweet Spot™ technology, allowing valve to open at -0.01 psi and seals at 0 psi and above. The MODA™ fire rated supply box shall have interlocking flanges that can connect to any MODA supply box in conjunction with a metal bracket. L-shape brackets are included for support based on wall rating (see instruction sheet). Boxes shall be manufactured of PVC, allowing solvent welded joints to be prepared in accordance with ASTM D2855 for PVC drainage systems (without the use of specialty cements).

Always consult local plumbing codes prior to installing a Sure-Vent® AAV. Individual, branch and circuit vents are permitted to terminate with a connection to a Sure-Vent® AAV. Reference detailed instructions on Oatey.com for specific guidance on Sure-Vent® AAV placement within a plumbing system.

PRODUCT NO.	DESCRIPTION	CTN. QTY.
37434	MODA, Sure-Vent, 160Branch/24 Stack DFU, Single Pack	1



### ACCESSORY COMPONENTS INCLUDE:



Faceplates



Test Plug



Sticker Cover for Debris Protection



Faceplate Insert



Intumescent Pad (Pre-Installed)



Center Support (For Added Rigidity)



Metal Brackets (2)



L-shape Brackets (2)



### APPROVALS & LISTINGS

**Listings:** ASSE 1050 & 1051, ICC ESR-1664, NSF Standard 14, IAPMO – Classified Mark, ASTM D 2665

**Code Approvals:** International Plumbing Code 2012  
Uniform Plumbing Code 2012

**Listed to Warnock Hersey to meet: ASTM E-814, CAN/ULC S115**

**2-Hour Design:** 2 hour (F), 83 min (T)

**1-Hour Design:** 1 hour (F), 45 min (T)

### FEATURES & MATERIALS

**Outlet Box & Brackets:** PVC

**Valve:** PVC with 2" NPT Threads

**Box Connection:** PVC ¼ Turn Adapter with Sealing Gasket

### PERFORMANCE SPECIFICATIONS

**Temperature Rating:** -40° F/-40° C to 150° F/66° C

**DFU Rating:** 20 (stack or branch)

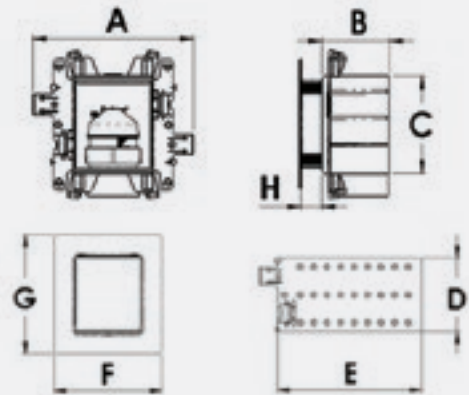

### DIMENSIONS

**A:** Box Width 8.00"

**B:** Box Depth 3.38"

**C:** Box Height 4.85"

**D:** Bracket Width 4.00"

**E:** Bracket Length 8.00"

**F:** Faceplate Width 6.00"

**G:** Faceplate Height 6.45"

**H:** Faceplate Depth 1.25"

Oatey



## FIRE-RATED LAVATORY SUPPLY BOX

### SPECIFICATIONS

Oatey MODA™ Fire-Rated Lavatory Supply Boxes shall be used in residential or commercial applications requiring a supply valve recessed in the wall. The MODA™ fire-rated lavatory assembly contains two 3/8" OD compression valves pre-installed in a PVC box, connected by inter-locking wing flanges. The wing flanges shall allow installation on a single stud in conjunction with the metal bracket. L-shape brackets are included for support based on wall rating (see instruction sheet). Valves shall be a two-piece design, permitting field replacement, and shall be secured with a stainless steel retention clip. Valves are available with or without water hammer arrestors and shall be installed upright. The assembly shall include an emergency drain port for protection from supply hose leaks.

PRODUCT NO.	DESCRIPTION	CTN. QTY.
<b>No Hammer</b>		
37392	LAV, Copper, NoHam, Single Pack	1
37393	LAV, F1807-Brass, NoHam, Single Pack	1
37395	LAV, F1960-Brass, NoHam, Single Pack	1
37397	LAV, CPVC, NoHam, Single Pack	1
37398	LAV, Push Cnc, NoHam, Single Pack	1
<b>Hammer</b>		
37399	LAV, Copper, Ham, Single Pack	1
37400	LAV, F1807-Brass, Ham, Single Pack	1
37402	LAV, F1960-Brass, Ham, Single Pack	1
37404	LAV, CPVC, Ham, Single Pack	1
37405	LAV, Push Cnc, Ham, Single Pack	1



### ACCESSORY COMPONENTS INCLUDE:



Faceplate



Intumescent Pad (Pre-Installed)



Sticker Cover for Debris Protection



Metal Brackets (1)



L-shape Brackets (2)

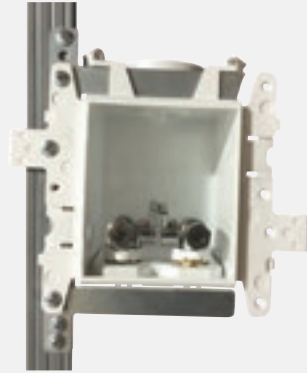

### APPROVALS & LISTINGS

**Valves:** ASME A112.18.1 / CSA B125.1 NSF / ANSI 61 & 372  
**Water Hammer Arrestors:** ASSE 1010, PDI WH 201

**Boxes:** IAPMO-Listed, PS-54

**Listed with Massachusetts Board of Plumbing  
 Listed by Warnock Hersey to meet: ASTM E814**

**2-Hour Design:** F-Rating: 2 Hour, T-Rating: 1-1/4 Hour

**1-Hour Design:** F-Rating: 1 Hour, T-Rating: 3/4 Hour

**CAN/ULC S115**

**2-Hour Design:** FH Rating: 2 Hour, FTH Rating: 1-1/4 Hour

**1-Hour Design:** FH Rating: 1 Hour, FTH Rating: 3/4 Hour

### FEATURES & MATERIALS

**Outlet Box & Brackets:** PVC

**Valve Body:** Forged Brass C46500 No Lead (Chrome Plated)

**Valve Retention Clip:** Stainless Steel

**Valve O-Rings:** NSF Approved EPDM (2)

**Metal Bracket and L-shape Brackets:** 16 Gauge Galvanized Steel

**Arrestor Body:** Copper (Type L)

**Piston:** Polypropylene with two NBR O-rings

**Piston Lubrication:** Dow Corning Molykote 111

### PERFORMANCE SPECIFICATIONS

**Temperature Rating (Valve):** 250° F/121° C

**Max Testing Pressure (Valve):** 100 psi (Air) / 250 psi (Water)

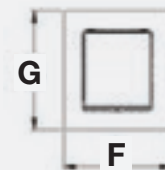
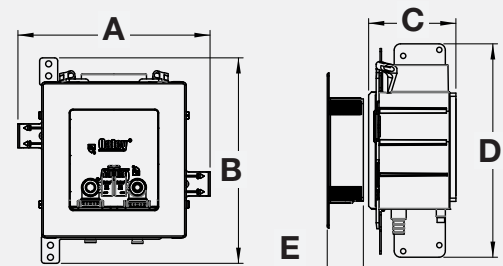

### DIMENSIONS

**A:** Box Width 7.98"

**B:** Box Height 8.46"

**C:** Box Depth 3.63"

**D:** Metal Bracket Height 8.87"

**E:** Faceplate Depth 1.25"

**F:** Faceplate Width 6.00"

**G:** Faceplate Height 6.45"



## FIRE-RATED KITCHEN SUPPLY BOXES

### SPECIFICATIONS

Oatey MODA™ Fire-Rated Kitchen Supply Boxes shall be used in residential or commercial applications requiring a supply valve recessed in the wall. The MODA™ fire-rated lavatory assembly contains three 3/8" OD compression valves pre-installed into two PVC boxes, connected by inter-locking wing flanges that can be easily disassembled and re-assembled. The wing flanges shall allow installation on a single stud in conjunction with the metal bracket. L-shape brackets are included for support based on wall rating (see instruction sheet). All double boxes can be interlocked for direct installation to steel and wood studs. They can also be installed independently on separate studs. Valves shall be a two-piece design, permitting field replacement, and shall be secured with a stainless steel retention clip. Valves are available with or without water hammer arrestors and shall be installed upright. The assembly shall include an emergency drain port for protection from supply hose leaks.

PRODUCT NO.	DESCRIPTION	CTN. QTY.
<b>No Hammer</b>		
37406	KTCN, Copper, NoHam, Single Pack	1
37407	KTCN, F1807-Brass, NoHam, Single Pack	1
37409	KTCN, F1960-Brass, NoHam, Single Pack	1
37411	KTCN, CPVC, NoHam, Single Pack	1
37412	KTCN, Push Cnc, NoHam, Single Pack	1
<b>Hammer</b>		
37413	KTCN, Copper, DW-Ham, Single Pack	1
37414	KTCN, F1807-Brass, DW-Ham, Single Pack	1
37416	KTCN, F1960-Brass, DW-Ham, Single Pack	1
37418	KTCN, CPVC, DW-Ham, Single Pack	1
37419	KTCN, Push Cnc, DW-Ham, Single Pack	1



### ACCESSORY COMPONENTS INCLUDE:



Faceplate



Intumescent Pad  
(Pre-Installed)



Sticker Cover for  
Debris Protection



Metal Brackets (2)



L-shape Brackets (4)

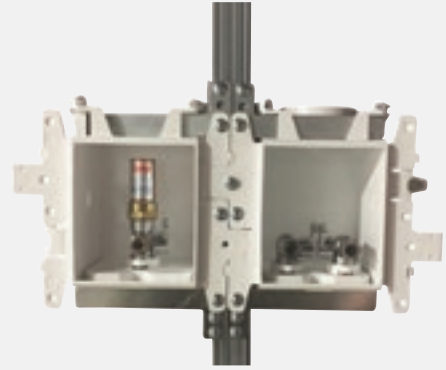

### APPROVALS & LISTINGS

**Valves:** ASME A112.18.1 / CSA B125.1 NSF / ANSI 61 & 372

**Water Hammer Arrestors:** ASSE 1010, PDI WH 201

**Boxes:** IAPMO-Listed, PS-54

**Listed with Massachusetts Board of Plumbing**

**Listed by Warnock Hersey to meet: ASTM E814**

**2-Hour Design:** F-Rating: 2 Hour, T-Rating: 1-1/4 Hour

**1-Hour Design:** F-Rating: 1 Hour, T-Rating: 3/4 Hour

**CAN/ULC S115**

**2-Hour Design:** FH Rating: 2 Hour, FTH Rating: 1-1/4 Hour

**1-Hour Design:** FH Rating: 1 Hour, FTH Rating: 3/4 Hour

### FEATURES & MATERIALS

**Outlet Box & Brackets:** PVC

**Valve Body:** Forged Brass C46500 No Lead (Chrome Plated)

**Valve Retention Clip:** Stainless Steel

**Valve O-Rings:** NSF Approved EPDM (2)

**Metal Bracket and L-shape Brackets:** 16 Gauge Galvanized Steel

**Arrestor Body:** Copper (Type L)

**Piston:** Polypropylene with two NBR O-rings

**Piston Lubrication:** Dow Corning Molykote 111

### PERFORMANCE SPECIFICATIONS

**Temperature Rating (Valve):** 250° F/121° C

**Max Testing Pressure (Valve):** 100 psi (Air) / 250 psi (Water)

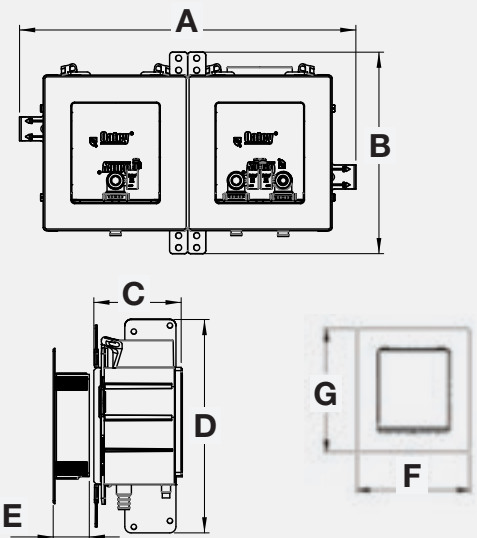

### DIMENSIONS

**A:** Box Width 13.96"

**B:** Box Height 8.46"

**C:** Box Depth 3.63"

**D:** Metal Bracket Height 8.87"

**E:** Faceplate Depth 1.25"

**F:** Faceplate Width 6.00"

**G:** Faceplate Height 6.45"

Oatey



## FIRE-RATED ICE MAKER SUPPLY BOX

### SPECIFICATIONS

Oatey MODA™ Fire-Rated Ice Maker Supply Boxes shall be used in residential or commercial applications requiring a supply valve recessed in the wall. The MODA™ fire-rated ice maker box assembly contains a 1/4" OD compression valve pre-installed in a PVC box, with inter-locking wing flanges on each side. The wing flanges in conjunction with the metal bracket allow for direct to stud installation. L-shape brackets are included for support based on wall rating (see instruction sheet). Valves shall be a two-piece design, permitting field replacement, and shall be secured with a stainless steel retention clip. Valves are available with or without water hammer arrestors and shall be installed upright. The assembly shall include an emergency drain port for protection from tubing leaks.

PRODUCT NO.	DESCRIPTION	CTN. QTY.
<b>No Hammer</b>		
37378	IMOB, Copper, NoHam, Single Pack	1
37379	IMOB, F1807-Brass, NoHam, Single Pack	1
37381	IMOB, F1960-Brass, NoHam, Single Pack	1
37383	IMOB, CPVC, NoHam, Single Pack	1
37384	IMOB, Push Cnc, NoHam, Single Pack	1
<b>Hammer</b>		
37385	IMOB, Copper, Ham, Single Pack	1
37386	IMOB, F1807-Brass, Ham, Single Pack	1
37388	IMOB, F1960-Brass, Ham, Single Pack	1
37390	IMOB, CPVC, Ham, Single Pack	1
37391	IMOB, Push Cnc, Ham, Single Pack	1



### ACCESSORY COMPONENTS INCLUDE:



Faceplate



Intumescent Pad (Pre-Installed)



Sticker Cover for Debris Protection



Metal Bracket (1)



L-shape Brackets (2)

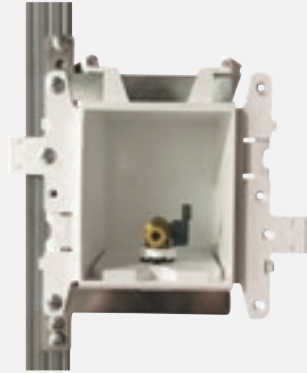

### APPROVALS & LISTINGS

**Valves:** ASME A112.18.1 / CSA B125.1 NSF / ANSI 61 & 372

**Water Hammer Arrestors:** ASSE 1010, PDI WH 201

**Boxes:** IAPMO-Listed, PS-54

**Listed with Massachusetts Board of Plumbing**

**Listed by Warnock Hersey to meet: ASTM E814**

**2-Hour Design:** F-Rating: 2 Hour, T-Rating: 1-1/4 Hour

**1-Hour Design:** F-Rating: 1 Hour, T-Rating: 3/4 Hour

**CAN/ULC S115**

**2-Hour Design:** FH Rating: 2 Hour, FTH Rating: 1-1/4 Hour

**1-Hour Design:** FH Rating: 1 Hour, FTH Rating: 3/4 Hour

### FEATURES & MATERIALS

**Outlet Box & Brackets:** PVC

**Valve Body:** Forged Brass C46500 No Lead

**Valve Retention Clip:** Stainless Steel

**Valve O-Rings:** NSF Approved EPDM (2)

**Metal Bracket and L-shape Brackets:** 16 Gauge Galvanized Steel

**Arrestor Body:** Copper (Type L)

**Piston:** Polypropylene with two NBR O-rings

**Piston Lubrication:** Dow Corning Molykote 111

### PERFORMANCE SPECIFICATIONS

**Temperature Rating (Valve):** 250° F/121° C

**Max Testing Pressure (Valve):** 100 psi (Air) / 250 psi (Water)

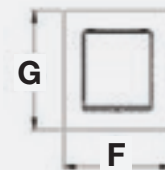
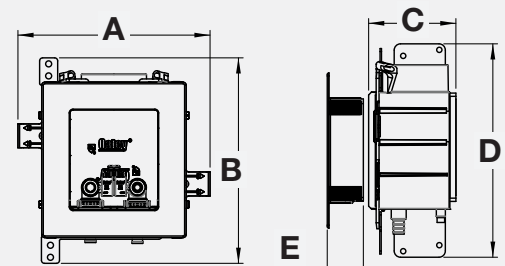

### DIMENSIONS

**A:** Box Width 7.98"

**B:** Box Height 8.46"

**C:** Box Depth 3.63"

**D:** Metal Bracket Height 8.87"

**E:** Faceplate Depth 1.25"

**F:** Faceplate Width 6.00"

**G:** Faceplate Height 6.45"



## FIRE-RATED GAS SUPPLY BOX

### SPECIFICATIONS

Oatey MODA™ Fire-Rated Gas Supply Boxes shall be used in gas supply systems for residential or commercial applications. Boxes shall allow for mounting direct-to-stud or between studs with supply line from bottom. Valves shall be available with yellow handle, with or without brass shank, and plastic brackets for between stud configuration. Outlet shall be 1/2" or 3/4" with 1/4 turn valve. Hercules Megaloc Thread Sealant shall be used with gas valves.

PRODUCT NO.	DESCRIPTION	CTN. QTY.
37446	MODA FR, BR, 1/2 NPT Valve, Single Pack	1
37447	MODA FR, BR, 3/4 NPT Valve, Single Pack	1



### ACCESSORY COMPONENTS INCLUDE:



Faceplate



Test Plug



Sticker Cover for Debris Protection



Intumescent Pad (Pre-Installed)



Metal Bracket (1)



L-shape Brackets (2)

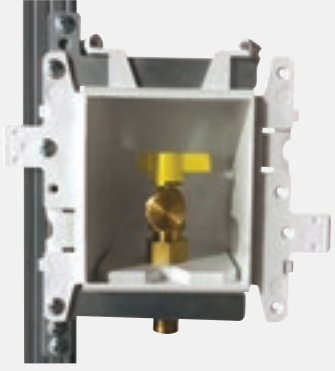

### APPROVALS & LISTINGS

**Valves:** ANSI Z21.15 / CSA9.1-2009 / ASME A112.18.1 / CSA B125.1 NSF / ANSI 61 & 372

**Boxes:** IAPMO-Listed, PS-54

**Listed with Massachusetts Board of Plumbing**

**Listed by Warnock Hersey to meet: ASTM E814**

**2-Hour Design:** F-Rating: 2 Hour, T-Rating: 1-1/4 Hour

**1-Hour Design:** F-Rating: 1 Hour, T-Rating: 3/4 Hour

**CAN/ULC S115**

**2-Hour Design:** FH Rating: 2 Hour, FTH Rating: 1-1/4 Hour

**1-Hour Design:** FH Rating: 1 Hour, FTH Rating: 3/4 Hour

### FEATURES & MATERIALS

**Outlet Box & Brackets:** PVC

**Valve Handle:** Aluminum Alloy

**Valve Body, Test Plug and Adapter:** Brass

**Locknut:** Zinc Alloy

**Valve Sizes (Outlets):** 1/2" & 3/4"

**Metal Bracket and L-shape Brackets:** 16 Gauge

Galvanized Steel

**Gas Types:** Natural gas, propane

### PERFORMANCE SPECIFICATIONS

**Max Working Pressure:** 1/2 PSIG

**Max Testing Pressure:** 10 PSI

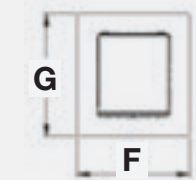
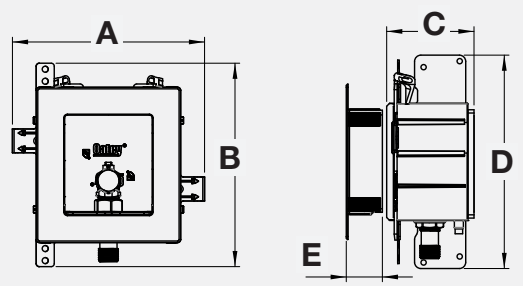

### DIMENSIONS

**A:** Box Width 7.98"

**B:** Box Height 8.46"

**C:** Box Depth 3.63"

**D:** Metal Bracket Height 8.87"

**E:** Faceplate Depth 1.25"

**F:** Faceplate Width 6.00"

**G:** Faceplate Height 6.45"



## FIRE-RATED WASHING MACHINE OUTLET BOXES

### SPECIFICATIONS

Oatey Fire-Rated Washing Machine Outlet Boxes can be used in applications requiring supply valves and waste drains recessed into a fire-rated wall. Unit shall allow for the mounting of supply lines from top or bottom on the left or right side. Unit shall be available with single lever or ¼ turn brass ball valves in configurations with and without water hammer arrestors listed to ASSE 1010. Adjustable metal support bracket shall be installed on top and bottom of unit for support in stud wall. Drain size to be 2" with ¼ turn test cap.

PRODUCT NO.	DESCRIPTION	CTN. QTY.
38470	1/4 Turn Brass Ball Valve, Copper Sweat, Standard Pack	1
38471	1/4 Turn Brass Ball Valve, CPVC, Standard Pack	1
38472	1/4 Turn Brass Ball Valve, 1/2" ASTM F1807 PEX, Standard Pack	1
38473	1/4 Turn Brass Ball Valve, 1/2" ASTM F1960 PEX, Standard Pack	1
38474	Single Lever Brass Ball Valve, Copper Sweat, Standard Pack	1
38475	Single Lever Brass Ball Valve, CPVC, Standard Pack	1
38476	Single Lever Brass Ball Valve, 1/2" ASTM F1807 PEX, Standard Pack	1
38477	Single Lever Brass Ball Valve, 1/2" ASTM F1960 PEX, Standard Pack	1
38478	1/4 Turn Brass Ball Valve with Water Hammer Arrestor, Copper Sweat, Standard Pack	1
38479	1/4 Turn Brass Ball Valve with Water Hammer Arrestor, CPVC, Standard Pack	1
38480	1/4 Turn Brass Ball Valve with Water Hammer Arrestor, 1/2" ASTM F1807 PEX, Standard Pack	1
38481	1/4 Turn Brass Ball Valve with Water Hammer Arrestor, 1/2" ASTM F1960 PEX, Standard Pack	1
38482	Single Lever Brass Ball Valve with Water Hammer Arrestor, Copper Sweat, Standard Pack	1
38483	Single Lever Brass Ball Valve with Water Hammer Arrestor, CPVC, Standard Pack	1
38484	Single Lever Brass Ball Valve with Water Hammer Arrestor, 1/2" ASTM F1807 PEX, Standard Pack	1
38485	Single Lever Brass Ball Valve with Water Hammer Arrestor, 1/2" ASTM F1960 PEX, Standard Pack	1
Accessories		
38494	Plain Washing Machine Outlet Box, without faceplate or brackets	1
38496	Washing Machine Outlet Box Faceplate	1
38498	Adjustable Metal Support Bracket, 2-pieces	1
38576	Washing Machine Outlet Box Test Cap	1

FyreWrap is a registered trademark of Unifrax LLC.



### APPROVALS & LISTINGS

#### ASTM E814

1-hour wall: 60 min. (F)      2-hour wall: 120 min (F)  
1-hour wall: 32 min (T)      2-hour wall: 85 min (T)

#### CAN/ULC S115

**1-hour wall:** 60 min. (F/FH)      **2-hour wall:** 120 min. (F/FH)  
**1-hour wall:** 32 min (FT/FTH)      **2-hour wall:** 85 min. (FT/FTH)

### MULTIPLE VALVE INSTALLATION OPTIONS:

Right-hand offset, bottom mount      Left-hand offset, bottom mount  
Right-hand offset, top mount      Left-hand offset, top mount

### ADJUSTABLE MOUNTING BRACKET:

Use nails or screws to secure into stud wall

**Faceplate:** Snap – on faceplate accommodates up to two layers of 5/8" gypsum

**Drain:** 2" Drain Piece fits 2" PVC or ABS Schedule 40 pipe

### FEATURES & MATERIALS

**Outlet Box:** Bulk Molded Compound (BMC), Thermostat fire-rated plastic      **Plugs:** Bulk Molded Compound (BMC) thermostat Fire-rated plastic

**Adjustable Mounting Bracket:** Galvanized Steel      **Test Cap:** PVC  
**2" DWV Drain Piece:** PVC      **Box Pad:** UL Classified FyreWrap Insulation Material

### Drain Piece Metal Sleeve:

Galvanized steel with integrated intumescent pad

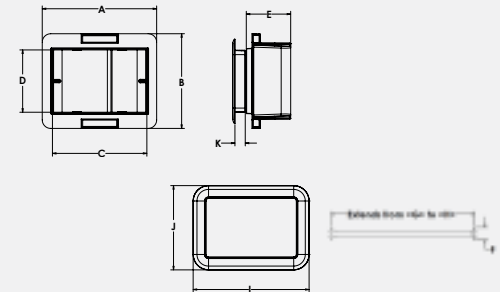

### DIMENSIONS

**A:** Box Width 10.10"      **F:** Bracket Height 1.22"  
**B:** Box Height 8.36"      **G:** Bracket Width 14.25"  
**C:** Box Opening Width 8.33"      **H:** Bracket Width 23.00"  
**D:** Box Opening Height 5.50"      **I:** Faceplate Width 10.24"  
**E:** Box Depth 3.92"      **J:** Faceplate Height 7.44"  
**K:** Faceplate Depth 0.91"



## METAL ICE MAKER SUPPLY BOXES

### SPECIFICATIONS

Oatey Metal Ice Maker Outlet Boxes can be used in applications requiring supply valves recessed into a wall. Unit shall allow for the mounting of supply lines from top or bottom on the left or right side. Unit shall be available with 1/4 turn brass ball valves in configurations with and without water hammer arrestor.

PRODUCT NO.	DESCRIPTION	CTN. QTY.
<b>No Hammer, Low Lead</b>		
39141	Metal, 1/4 Turn, Copper, Low Lead - Standard Pack	1
<b>Hammer, Low Lead</b>		
39140	Metal, 1/4 Turn, Copper, Low Lead - Standard Pack	1
<b>Accessories</b>		
38687	Metal, Plain Box, No Valves - Standard Pack	1
38686	Metal Faceplate	1



### APPROVALS & LISTINGS

**Valves:** ASME A112.18.1 /NSF Standard 61, Section 9

**Water Hammer Arrestors:** ASSE 1010

### FEATURES & MATERIALS

**Outlet Box:** 20 Gauge Steel

**Faceplate:** 28 Gauge Steel

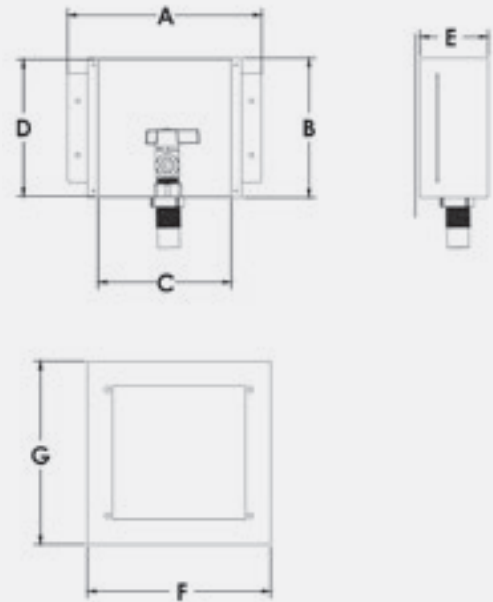

### DIMENSIONS

**A:** Box Width 7.16"

**B:** Box Height 5.15"

**C:** Box Opening Width 4.91"

**D:** Box Opening Height 5.04"

**E:** Box Depth 2.5"

**F:** Bracket Height 6.75"

**G:** Bracket Width 6.75"

*STANDARD PACK: Faceplates are pre-assembled on box.*

*CONTRACTOR PACK: Faceplates are NOT pre-assembled on box (but come separately packed with the box).*





## FIRE-RATED ICE MAKER OUTLET BOXES

### SPECIFICATIONS

Oatey Fire-Rated Ice Maker Outlet Boxes can be used in applications requiring supply valves recessed into a fire-rated wall. Unit shall allow for the mounting of supply lines from top or bottom on the left or right side. Unit shall be available with 1/4 turn brass ball valves in configurations with and without water hammer arrestors listed to ASSE 1010. Adjustable metal support bracket shall be installed on top and bottom of unit for support in stud wall.

PRODUCT NO.	DESCRIPTION	CTN. QTY.
<b>No Hammer, Low Lead</b>		
39117	1/4 Turn Brass Ball Valve - Low Lead - Copper Sweat - Standard Pack	1
39118	1/4 Turn Brass Ball Valve - Low Lead - CPVC- Standard Pack	1
39119	1/4 Turn Brass Ball Valve - Low Lead - 1/2" ASTM F1807 PEX - Standard Pack	1
39120	1/4 Turn Brass Ball Valve - Low Lead - 1/2" ASTM F1960 PEX - Standard Pack	1
39121	1/4 Turn Brass Hammer Ball Valve - Low Lead - Copper Sweat Standard Pack	1
39122	1/4 Turn Brass Hammer Ball Valve - Low Lead - CPVC Standard Pack	1
39123	1/4 Turn Brass Hammer Ball Valve - Low Lead - 1/2" ASTM F1807 PEX - Standard Pack	1
39124	1/4 Turn Brass Hammer Ball Valve - Low Lead - 1/2" ASTM F1960 PEX - Standard Pack	1
<b>Accessories</b>		
38495	Plain Fire Ice Maker Outlet Box, without faceplate or brackets	6
38497	Ice Maker Outlet Box Faceplate	6
38498	Adjustable Metal Support Bracket, 2-pieces	6

FyreWrap is a registered trademark of Unifrax LLC.



### APPROVALS & LISTINGS

#### ASTM E814

1-hour wall: 60 min. (F)  
1-hour wall: 32 min (T)  
2-hour wall: 120 min (F)  
2-hour wall: 85 min (T)

#### CAN/ULC S115

**1-hour wall:** 60 min. (F/FH)  
**1-hour wall:** 32 min (FT/FTH)  
**2-hour wall:** 120 min. (F/FH)  
**2-hour wall:** 85 min. (FT/FTH)

#### ADJUSTABLE MOUNTING BRACKET:

Use nails or screws to secure into stud wall

**Faceplate:** Snap –on faceplate accommodates up to two layers of 5/8" gypsum

#### FEATURES & MATERIALS

**Outlet Box:** Bulk Molded Compound (BMC), Thermoset fire-rated plastic

**Adjustable Mounting Bracket:** Galvanized Steel

**Box Pad:** UL Classified FyreWrap Insulation Material

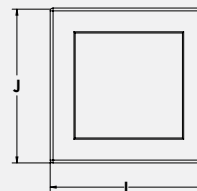
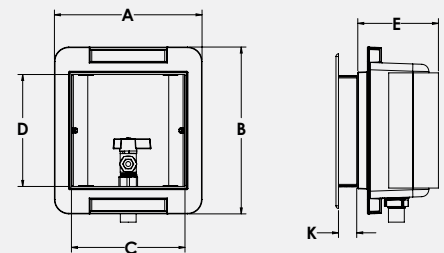

#### DIMENSIONS

**A:** Box Width 7.69"

**B:** Box Height 8.69"

**C:** Box Opening Width 5.91"

**D:** Box Opening Height 5.83"

**E:** Box Depth 4.20"

**F:** Bracket Height 1.22"

**G:** Bracket Width 14.25"

**H:** Bracket Width 23.00"

**I:** Faceplate Width 8.19"

**J:** Faceplate Height 8.01"

**K:** Faceplate Depth 0.95"



WASHING MACHINE VALVES, NO HAMMER

PRODUCT NO.	DESCRIPTION	CTN. QTY.
<b>Standard Side Handle Valves</b>		
39320	WMOB Valve, 1/4 Turn, Copper, No Hammer, Gray Handle, Hot	1
39321	WMOB Valve, 1/4 Turn, Copper, No Hammer, Gray Handle, Cold	1
39325	WMOB Valve, 1/4 Turn, CPVC, No Hammer, Gray Handle, Hot	1
39326	WMOB Valve, 1/4 Turn, CPVC, No Hammer, Gray Handle, Cold	1
39330	WMOB Valve, 1/4 Turn, F1807, No Hammer, Gray Handle, Hot	1
39331	WMOB Valve, 1/4 Turn, F1807, No Hammer, Gray Handle, Cold	1
39335	WMOB Valve, 1/4 Turn, F1960, No Hammer, Gray Handle, Hot	1
39336	WMOB Valve, 1/4 Turn, F1960, No Hammer, Gray Handle, Cold	1
<b>Standard Top Handle Valves</b>		
39322	WMOB Valve, 1/4 Turn, Copper, No Hammer, Gray Top Handle	1
39327	WMOB Valve, 1/4 Turn, CPVC, No Hammer, Gray Top Handle	1
39332	WMOB Valve, 1/4 Turn, F1807, No Hammer, Gray Top Handle	1
39337	WMOB Valve, 1/4 Turn, F1960, No Hammer, Gray Top Handle	1
<b>Quadro Valves</b>		
39340	Quadro Valve, 1/4 Turn, Copper, No Hammer, Red Handle, Hot	1
39353	Quadro Valve, 1/4 Turn, Copper, No Hammer, Blue Handle, Cold	1
39341	Quadro Valve, 1/4 Turn, CPVC, No Hammer, Red Handle, Hot	1
39354	Quadro Valve, 1/4 Turn, CPVC, No Hammer, Blue Handle, Cold	1
39342	Quadro Valve, 1/4 Turn, F1807, No Hammer, Red Handle, Hot	1
39355	Quadro Valve, 1/4 Turn, F1807, No Hammer, Blue Handle, Cold	1
39343	Quadro Valve, 1/4 Turn, F1960, No Hammer, Red Handle, Hot	1
39356	Quadro Valve, 1/4 Turn, F1960, No Hammer, Blue Handle, Cold	1



## HAMMER ARRESTOR VALVES, ICE MAKER OUTLET BOX VALVES AND ACCESSORIES

PRODUCT NO.	DESCRIPTION	CTN. QTY.
<b>Standard Side Handle Valves with Hammer Arrestor</b>		
39323	WMOB Valve, 1/4 Turn, Copper, Hammer, Gray Handle, Hot	1
39324	WMOB Valve, 1/4 Turn, Copper, Hammer, Gray Handle, Cold	1
39328	WMOB Valve, 1/4 Turn, CPVC, Hammer, Gray Handle, Hot	1
39329	WMOB Valve, 1/4 Turn, CPVC, Hammer, Gray Handle, Cold	1
39333	WMOB Valve, 1/4 Turn, F1807, Hammer, Gray Handle, Hot	1
39334	WMOB Valve, 1/4 Turn, F1807, Hammer, Gray Handle, Cold	1
39338	WMOB Valve, 1/4 Turn, F1960, Hammer, Gray Handle, Hot	1
39339	WMOB Valve, 1/4 Turn, F1960, Hammer, Gray Handle, Cold	1
<b>Quadro Valves with Hammer Arrestor</b>		
39344	Quadro Valve, 1/4 Turn, Copper, Hammer, Red Handle, Hot	1
39357	Quadro Valve, 1/4 Turn, Copper, Hammer, Blue Handle, Cold	1
39345	Quadro Valve, 1/4 Turn, CPVC, Hammer, Red Handle, Hot	1
39358	Quadro Valve, 1/4 Turn, CPVC, Hammer, Blue Handle, Cold	1
39346	Quadro Valve, 1/4 Turn, F1807, Hammer, Red Handle, Hot	1
39347	Quadro Valve, 1/4 Turn, F1960, Hammer, Red Handle, Hot	1
39359	Quadro Valve, 1/4 Turn, F1807, Hammer, Blue Handle, Cold	1
39360	Quadro Valve, 1/4 Turn, F1960, Hammer, Blue Handle, Cold	1

PRODUCT NO.	DESCRIPTION	CTN. QTY.
<b>No Hammer – Low Lead</b>		
39176	IMOB Valve, 1/4 Turn, Copper, No Hammer, Low Lead	1
39175	IMOB Valve, 1/4 Turn, CPVC, No Hammer, Low Lead	1
39173	IMOB Valve, 1/4 Turn, F1960 No Hammer, Low Lead	1
39174	IMOB Valve, 1/4 Turn, F1807, No Hammer, Low Lead	1
39171	IMOB Valve, Boiler Drain, Copper, No Hammer, Low Lead	1
<b>Hammer Low – Lead</b>		
39166	IMOB Valve, 1/4 Turn, Copper, Hammer, Low Lead	1
39167	IMOB Valve, 1/4 Turn, CPVC, Hammer, Low Lead	1
39168	IMOB Valve, 1/4 Turn, F1807, Hammer, Low Lead	1
39169	IMOB Valve, 1/4 Turn, F1960, Hammer, Low Lead	1

PRODUCT NO.	DESCRIPTION	CTN. QTY.
38294	Hot/Cold Temperature Indicator Clips for Supply Valves (12 Red, 12 Blue)	24
38295	Single Lever Handle Connector	12
38779	Adapter 1/2" Female NPT X 1/2" Copper	1
38829	Locknut 1/2" Plastic	1
38769	Grommets 1/2"	12
38440	Drain, MIP w/ Adapter Long Shank	1





**HAMMER  
ARRESTORS**

PRESSURIZED

PREVENT  
BANGING

PRESS FITTINGS

CONTROLLED

SILENCE

REPUTABLE

LEADERSHIP

DISSIPATED

COMPREHENSIVE

FLOW VELOCITY

LEAD-FREE

**Oatey** COMMERCIAL

NO TOOLS NECESSARY

OUTPERFORM

COPPER

PUSH FITTINGS

POLYPROPYLENE

QUICK-CLOSING VALVES

PROBLEM-SOLVING

EFFECTIVE

ABSORB WATER SHOCK

MINIMAL TIME

RESIDENTIAL

EFFICIENT



# HAMMER ARRESTORS

**SILENCE THE WATER HAMMER.**

The persistent clanking, banging and pounding in your pipes behind the wall might sound like a tiny war is being waged but have no fear, Oatey Quiet Pipes® is finally here.

That annoying sound is called water hammer and it can happen just about anywhere in any type of building. Water hammer can occur when flushing your toilet, turning on or off a water valve or even with the changing of cycles in your washing machine. The change in water flow causes waves inside the pipes that create a hammer sound. Depending on the size of the plumbing system, water hammer can cause serious damage to pipes.

Left untreated, water hammer can harm different parts of the plumbing system including pipe supports, faucets, valves and even water heaters.



# QUIET PIPES®

## WATER HAMMER ARRESTORS SIZE A-F

### SPECIFICATIONS

Oatey Quiet Pipes Hammer Arrestors shall be installed in any diameter pipe supply application which could experience water hammer due to quick closing valves or faucets. Arrestor chambers shall be specifically sized to accommodate and dissipate energy generated by such valves and faucets. Arrestors shall be effective when installed at any angle. Arrestor shall be lead-free, made of copper and include a polypropylene piston with two NBR O-rings. Arrestors shall be ANSI/ASSE1010-2004 certified and approved for installation with no access panel required.

PRODUCT NO.	DESCRIPTION	CTN. QTY.
34476	A, 1/2" F1960 PEX	12
34481	A, 1/2" MIP	12
34482	A, 1/2" F1807 PEX	12
34499	A, 1/2" Male Sweat/Press	12
34491	A, 1/2" Female CPVC	24
34500	B, 3/4" Male Sweat/Press	12
34484	B, 3/4" MIP	30
34492	B, 3/4" Female CPVC	24
34493	B, 3/4" F1807 PEX	30
34495	B, 3/4" F1960 PEX	30
34477	C, 1" Female CPVC	12
34497	D, 1" MIP	6
34485	C, 1" MIP	24
34501	C, 1" Male Sweat/Press	6
34494	C, 1" F1807 PEX	24
34496	C, 1" F1960 PEX	24
34502	D, 1" Male Sweat/Press	6
34479	E, 1" MIP	6
34503	E, 1" Male Sweat/Press	6
34480	F, 1" MIP	6
34504	F, 1" Male Sweat/Press	6

### DIMENSIONS

Arrestor Size:	A	A	A	A	A	B	B
Product #:	34476	34481	34482	34499	34491	34500	34484
Arrestor Body Diameter [A]:	1.13"	1.13"	1.13"	1.13"	1.13"	1.13"	1.13"
Overall Height [B]:	4.78"	4.78"	4.68"	6.73"	5.30"	7.31"	5.41"
Fitting Type [C]:	F1960 PEX	MIP	F1807 PEX	Male Sweat/Press	Female CPVC	Male Sweat/Press	MIP
Fitting Size [C]:	1/2"	1/2"	1/2"	1/2"	1/2"	3/4"	3/4"

Arrestor Size:	B	B	B	C	C	C	C
Product #:	34492	34493	34495	34477	34485	34501	34494
Arrestor Body Diameter [A]:	1.13"	1.13"	1.13"	1.38"	1.38"	1.38"	1.38"
Overall Height [B]:	5.95"	5.34"	5.65"	7.02"	6.76"	8.45"	6.59"
Fitting Type [C]:	Female CPVC	F1807 PEX	F1960 PEX	Female CPVC	MIP	Male Sweat/Press	F1807 PEX
Fitting Size [C]:	3/4"	3/4"	3/4"	1"	1"	1"	1"

Arrestor Size:	C	D	D	E	E	F	F
Product #:	34496	34502	34497	34479	34503	34480	34504
Arrestor Body Diameter [A]:	1.38"	1.63"	1.63"	2.13"	2.13"	2.13"	2.13"
Overall Height [B]:	6.98"	10.08"	8.10"	9.26"	11.00"	11.25"	13.00"
Fitting Type [C]:	F1960 PEX	Male Sweat/Press	MIP	MIP	Male Sweat/Press	MIP	Male Sweat/Press
Fitting Size [C]:	1"	1"	1"	1"	1"	1"	1"



### APPROVALS & LISTINGS

ANSI/ASSE1010-2004 / cUPC / PDI WH-201-2017

### FEATURES & MATERIALS

**Arrestor Body:** Copper (Type K)

**Piston:** Polypropylene with two NBR O-rings

**Piston Lubrication:** Dow Corning Molykote 111

**Fittings Available:** Male Sweat/Press, Female CPVC, MIP, F1807 PEX & F1960 PEX (no lead brass C46400)

### PERFORMANCE SPECIFICATIONS

**Temperature Range:** 33° - 180° F

**Max Working Pressure:** 0-400 PSI

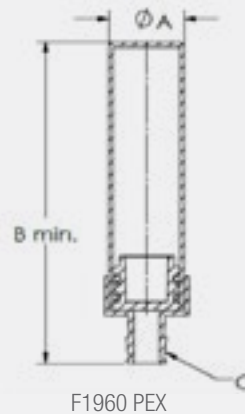



# QUIET PIPES® HAMMER ARRESTORS SIZE AA

## SPECIFICATIONS

Oatey Quiet Pipes Hammer Arrestors shall be installed in any small diameter pipe supply application which could experience water hammer due to quick closing valves or faucets. Arrestor chambers shall be specifically sized to accommodate and dissipate energy generated by such valves and faucets. Arrestors shall be effective when installed at any angle. Arrestor shall be lead-free, made of copper and include a polypropylene piston with two NBR O-rings. Arrestors shall be ANSI/ASSE1010-2004, listed and approved for installation with no access panel required. Compatible with press fittings or push fittings.

PRODUCT NO.	DESCRIPTION	CTN. QTY.
34498	AA, 1/2" Male Sweat/Press	30
34458	AA, 1/2" Female CPVC	30
34459	AA, 1/2" Male CPVC	30
34460	AA, 1/2" F1960 PEX	30
34461	AA, 1/2" F1807 PEX	30
39177	AA, 1/2" MIP	6
38600	AA, 3/4" x 3/4" Washing Machine	6
34463	AA, 3/4" Male Sweat/Press	30



## DIMENSIONS

Arrestor Size:	AA	AA	AA	AA	AA	AA	AA	AA
Product #:	34498	34458	34459	34460	34461	39177	38600	34463
Arrestor Body Diameter [A]:	0.88"	0.88"	0.88"	0.88"	0.88"	0.88"	0.88"	0.88"
Overall Height [B]:	5.57"	2.97"	2.97"	3.85"	3.87"	3.28"	4.16"	5.36"
Fitting Type [C]:	Male Sweat/Press	Female CPVC	Male CPVC	F1960 PEX	F1807 PEX	MIP	Branch	Male Sweat/Press
Fitting Size [C]:	1/2"	1/2"	1/2"	1/2"	1/2"	1/2"	3/4"	3/4"



## APPROVALS & LISTINGS

ANSI/ASSE1010-2004 / cUPC / PDI WH-201-2017

## FEATURES & MATERIALS

**Arrestor Body:** Copper (Type L)

**Piston:** Polypropylene with two NBR O-rings

**Piston Lubrication:** Dow Corning Molykote 111

**Fittings Available:** Male Sweat/Press, Female CPVC, Male CPVC, F1807 PEX & F1960 PEX (no lead brass C46400)

## PERFORMANCE SPECIFICATIONS

**Temperature Range:** 33°– 180° F

**Max Working Pressure:** 0–60 PSI

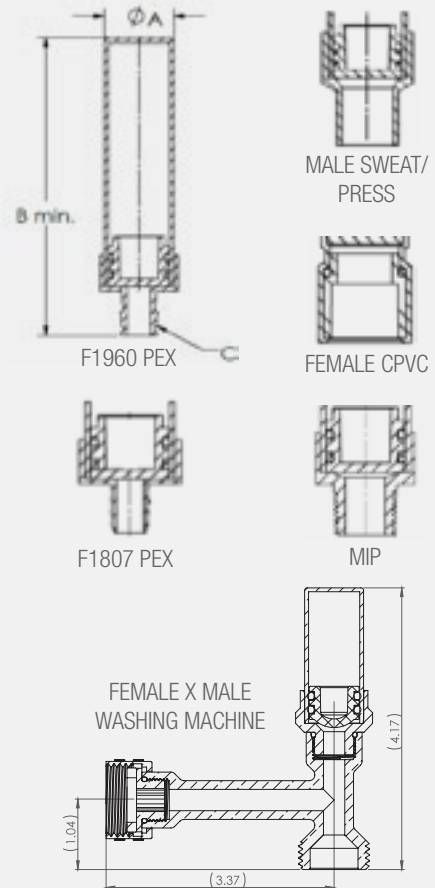



# QUIET PIPES®

## HAMMER ARRESTORS TEE FITTING

### SPECIFICATIONS

Oatey Quiet Pipes Hammer Arrestors shall be installed in any diameter pipe supply application which could experience water hammer due to quick closing valves or faucets. Arrestor chambers shall be specifically sized to accommodate and dissipate energy generated by such valves and faucets. Arrestors shall be effective when installed at any angle. Arrestor shall be lead-free, made of copper and include a polypropylene piston with two NBR o-rings. Arrestors shall conform to ANSI/ASSE1010-2004, listed and approved for installation with no access panel required.

PRODUCT NO.	DESCRIPTION	CTN. QTY.
34473	AA, 1/4" O.D. Compression	30
34475	AA, 1/4" Female Compression	30
34465	AA, 3/8" Female Compression	30
34474	AA, 3/8" O.D. Compression	30
34471	AA, 1/2" F1960 PEX	30
34472	AA, 1/2" F1807 PEX	30
34467	AA, 5/8" Female Compression	30



### DIMENSIONS

Arrestor Size:	AA	AA	AA	AA	AA	AA	AA
<b>Product #:</b>	34473	34475	34465	34474	34471	34472	34467
<b>Arrestor Body Diameter [A]:</b>	0.88"	0.88"	0.88"	0.88"	0.88"	0.88"	0.88"
<b>Overall Height [B]:</b>	2.75"	2.75"	2.75"	2.75"	2.75"	2.75"	2.75"
<b>Connection Type [C]:</b>	O.D. Comp.	Female Comp.	Female Comp.	O.D. Comp.	F1960 PEX	F1807 PEX	Female Comp.
<b>Connection Type [D]:</b>	O.D. Comp.	O.D. Comp.	O.D. Comp.	O.D. Comp.	F1960 PEX	F1807 PEX	O.D. Comp.
<b>Connection Size</b>	1/4"	1/4"	3/8"	3/8"	1/2"	1/2"	5/8"



### APPROVALS & LISTINGS

ANSI/ASSE1010-2004 / cUPC / PDI WH-201-2017

### FEATURES & MATERIALS

**Arrestor Body:** Copper (Type L)

**Piston:** Polypropylene with two NBR O-rings

**Piston Lubrication:** Dow Corning Molykote 111

**Fittings Available:** Female Compression, O.D. Compression, F1807 PEX & F1960 PEX (no lead brass C46400)

### PERFORMANCE SPECIFICATIONS

**Temperature Range:** 33°– 180° F

**Max Working Pressure:** 0–60 PSI

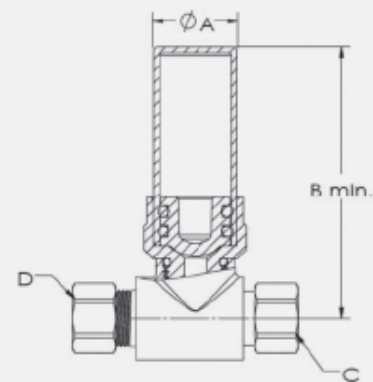



UNMATCHED PERFORMANCE **AIR ADMITTANCE VALVES**

LIFETIME PERFORMANCE

EASILY ACCOMMODATING

**DURABLE**

CONSISTENCY

FLEXIBLE FOAM

INNOVATION

SURE-VENT

REDUCED LABOR

SOLUTION

FORM FIT DESIGN

PATENTED TENSION MEMBRANE

EXCELLENCE

**QUALITY**

ADVANCED SEALING TECHNOLOGY

**VALUE**

**Oatey** COMMERCIAL

ISLAND SINK

SWEET SPOT

EFFICIENT

SUPERIOR ENGINEERING

PRESSURE SENSITIVITY

**TRUSTED**

**CONVENIENT**

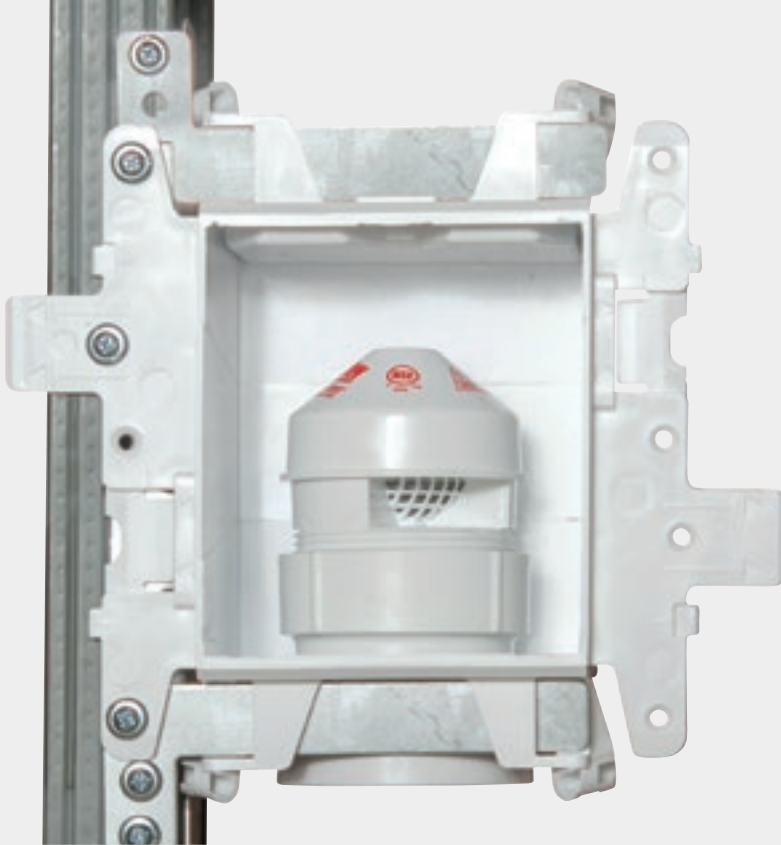
**Oatey**

# AIR ADMITTANCE VALVES (AAV)

Sensitivity to pressure changes, combined with its ability to consistently open and close, is what distinguishes the Oatey® Sure-Vent® AAV from all others. Superior engineering along with stringent quality standards ensure a lifetime of unmatched performance. Available in 6, 20, 160, and 500 DFU.

**SPECIFICATIONS**

The purpose of an Air Admittance Valve is to provide a method of allowing air to enter the plumbing drainage system without the use of a vent extended to open air and to prevent sewer gases from escaping into a building. An Air Admittance Valve is a one way valve designed to allow air to enter the plumbing drainage system when negative pressures develop in the piping system. The device shall close by gravity and seal the vent terminal at zero differential pressure (no flow conditions) and under positive internal pressures.

PRODUCT NO.	DESCRIPTION	PACK	CTN. WT.
<b>20 Branch, 8 Stack DFU Sure-Vent Air Admittance Valve With Schedule 40 Adapter</b>			
39228	20 Branch, 8 Stack DFU Sure-Vent, 1.5 In, W/PVC Sch. 40 Adapter	6	2.2 lbs.
39229	20 Branch, 8 Stack DFU Sure-Vent, 1.5 In, W/ABS Sch. 40 Adapter	6	2.2 lbs.
39005	20 Branch, 8 Stack DFU Sure-Vent, 1.5 In PVC Sch. 40 Adapter	50	18 lbs.
39227	20 Branch, 8 Stack DFU Sure-Vent, 1.5 In W/Abs Sch. 40 Adapter	6	18 lbs.
39250	20 Branch, 8 Stack DFU Sure-Vent, 1.5 In, 90 Deg PVC Sch. 40 Adapter	50	18 lbs.
39251	20 Branch, 8 Stack DFU Sure-Vent, 1.5 In, 90 Deg ABS Sch. 40 Adapter	6	18 lbs.
39254	20 Branch, 8 Stack DFU Sure-Vent, 1.5 In, Straight PVC Sch. 40 Adapter	50	18 lbs.
39256	20 Branch, 8 Stack DFU Sure-Vent, 1.5 In, Straight ABS Sch. 40 Adapter	50	18 lbs.
39255	20 Branch, 8 Stack DFU Sure-Vent, 1.5 In, Straight PVC Sch. 40 Adapter	6	2.2 lbs.
39020	20 Branch, 8 Stack DFU Sure-Vent, 1.5 In, No Adapter	6	2.2 lbs.
<b>20 Branch, 8 Stack DFU Sure-Vent Air Admittance Valve With Schedule 40 Adapter</b>			
39225	20 Branch, 8 Stack DFU Sure-Vent, 1.5 In White Tubular Adapter	6	3 lbs.
39226	20 Branch, 8 Stack DFU Sure-Vent, 1.5 In Black Tubular Adapter	6	3 lbs.
39239	20 Branch, 8 Stack DFU Sure-Vent, 1.5 In, Installation Pack W/ Tubular Adapter	6	3 lbs.
39020	20 Branch, 8 Stack DFU Sure-Vent, 1.5 In, No Adapter	50	5 lbs.
392393	20 Branch, 8 Stack DFU Sure-Vent, 1.5 In, Installation Pack- 3 Pack	6	3 lbs.
39245	20 Branch, 8 Stack DFU Sure-Vent, 1.5 In, Trap Pack	30	14 lbs.
<b>160 Branch, 24 Stack DFU Sure-Vent Air Admittance Valve With Schedule 40 Adapter</b>			
39016	160 Branch, 24 Stack DFU Sure-Vent, 1.5 x 2 In PVC Sch. 40 Adapter	6	2.2 lbs.
39018	160 Branch, 24 Stack DFU Sure-Vent, 1.5 x 2 In ABS Sch. 40 Adapter	6	2.2 lbs.
39017	160 Branch, 24 Stack DFU Sure-Vent, 1.5 x 2 In PVC Sch. 40 Adapter	50	18 lbs.
39019	160 Branch, 24 Stack DFU Sure-Vent, 1.5 x 2 In ABS Sch. 40 Adapter	50	18 lbs.
39238	160 Branch, 24 Stack DFU Sure-Vent, 1.5 In W/Mechanical Adapter	12	4 lbs.
<b>160 Branch, 72 Stack Dfu Sure-Vent Air Admittance Valve With Schedule 40 Adapter</b>			
39220	160 Branch, 72 Stack DFU Sure-Vent, 2 x 3 In PVC Sch. 40 Adapter	6	3.2 lbs.
39221	160 Branch, 72 Stack DFU Sure-Vent, 2 x 3 In ABS Sch. 40 Adapter	6	3.2 lbs.
<b>160 Branch, 500 Stack Dfu Sure-Vent Air Admittance Valve With Schedule 40 Adapter</b>			
39223	160 Branch, 500 Stack DFU Sure-Vent, 3 x 4 In PVC Sch. 40 Adapter	6	5 lbs.
39224	160 Branch, 500 Stack DFU Sure-Vent, 3 x 4 In ABS Sch. 40 Adapter	6	5 lbs.



	DFU Rating	Connection	Membrane	Adapter
<b>A</b>	20 Branch, 8 Stack	1.5" PVC NPT Threads	Silicone	1.5" PVC
<b>B</b>	160 Branch, 24 Stack	2" PVC NPT Threads	Silicone	1.5" x 2" PVC or ABS
<b>C</b>	160 Branch, 72 Stack	2" PVC NPT Threads	Silicone	2" x 3" PVC or ABS
<b>D</b>	160 Branch, 500 Stack	3" PVC NPT Threads	Silicone	3" x 4" PVC or ABS



AIR ADMITTANCE VALVES

**APPROVALS & LISTINGS**

ASSE 1050 & 1051 / ICC ESR-1664 / NSF Standard 14 / IAPMO – Classified Mark / ASTM D 2665/D 2661 / International Plumbing Code (IPC) 2003 / International Residential Code (IRC) 2003

**FEATURES & MATERIALS**

- Tension Membrane:** Silicone
- Sweet Spot™:** Sweet Spot™ technology opens at -0.01 psi and seals at 0 psi and above
- Screening:** Screening on air inlets to guard the seal
- Grip:** Protective sleeve provides grip for installation and keeps valve free from debris
- Tested:** 100% functionally tested at 1/4" H<sub>2</sub>O and 30" H<sub>2</sub>O ensuring trouble free performance
- Warranty:** Limited Warranty

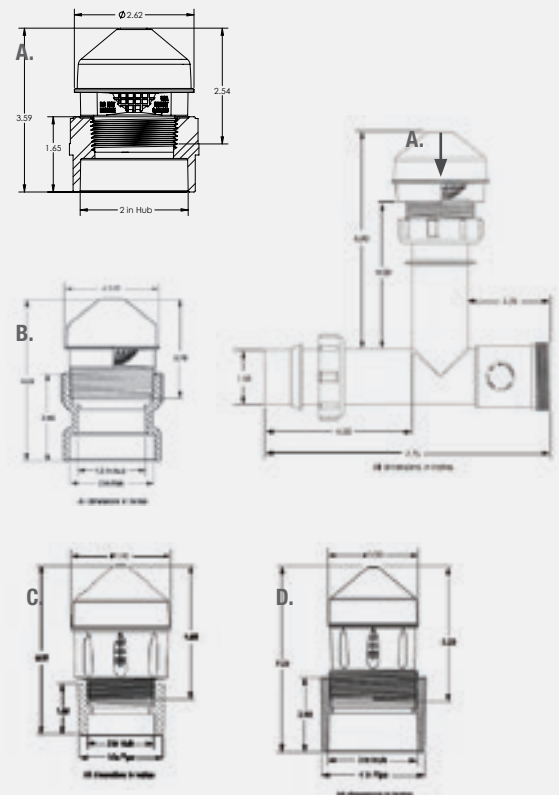



# SURE-VENT®

**AIR ADMITTANCE VALVE – 160 DFU  
CAPACITY, 500 DFU CAPACITY, METAL WALL,  
WALL BOX**

## ACCESSORIES

- Allows access to Sure-Vent air admittance valve.
- Fits Oatey Sure-Vents – 6, 20, 160 DFU (Sold Separately.)

PRODUCT NO.	DESCRIPTION	CTN. QTY.
39010	Sure-Vent Wall Box with Metal Grille Faceplate	12
39011	Metal Grille Faceplate for Wall Box	10

- New, smaller size: 4-1/2" x 5-3/4".
- High-impact polystyrene construction.
- Accommodates 6 or 20 DFU AAVs with 1-1/2" or 2" adapters.
- UPC listed.

PRODUCT NO.	DESCRIPTION	CTN. QTY.
39260	Box Kit	6
39261	Louvered Faceplate	6
39262	Box Kit with PVC Adapter and 20 DFU AAV	6
39263	Box Kit with ABS Adapter and 20 DFU AAV	6



## PLAIN BOXES

- One universal faceplate is compatible with all MODA boxes. Every plain box comes with faceplate and side brackets.
- Unique interlocking wing flanges accommodate on-stud, straddle-stud and three-box installation.
- Tough PVC construction and no transition cement needed when solvent welding PVC.

PRODUCT NO.	DESCRIPTION	CTN. QTY.
37981	MODA Sure-Vent, 160 Branch/ 24 Stack DFU, Standard	12



**FIRE-RATED AIR ADMITTANCE VALVES**

**SPECIFICATIONS**

Oatey MODA™ Fire-Rated Sure-Vent® Air Admittance Valves provide a method of allowing air to enter the plumbing drainage system without the use of a vent extended to open air and to prevent sewer gases from escaping into a building. An air admittance valve is a one way valve designed to allow air to enter the plumbing drainage system when negative pressures develop in the piping system. The device shall close by gravity and seal the vent terminal at zero differential pressure (no flow conditions) and under positive internal pressures. Valves shall be 100% functionally tested at 1/4" H<sub>2</sub>O and 30" H<sub>2</sub>O water column. The valves shall utilize a soft-centered, silicone membrane with Sweet Spot™ technology, allowing valve to open at -0.01 psi and seals at 0 psi and above. The MODA fire rated supply box shall have interlocking flanges that can connect to any MODA supply box in conjunction with a metal bracket. L-shape brackets are included for support based on wall rating (see instruction sheet). Boxes shall be manufactured of PVC, allowing solvent welded joints to be prepared in accordance with ASTM D2855 for PVC drainage systems (without the use of specialty cements).

PRODUCT NO.	DESCRIPTION
37434	MODA Sure-Vent, 160 Branch/24 Stack DFU, Single Pack



**ACCESSORY COMPONENTS INCLUDE:**



Faceplates



Intumescent Pad (Pre-Installed)



Sticker Cover for Debris Protection



Faceplate Insert



Metal Brackets (1)



L-shape Brackets (2)



Test Plug



**APPROVALS & LISTINGS**

ASSE 1050 & 1051 / ICC ESR-1664 / NSF Standard 14/ IAPMO – Classified Mark / ASTM D 2665/ International Plumbing Code 2012 / Uniform Plumbing Code 2012 / **Listed with Massachusetts Board of Plumbing**  
**Listed by Warnock Hersey to meet:**

**ASTM E814/UL 1479**

**2-Hour Design F-Rating:** 2 Hour, T-Rating: 1-1/4 Hour

**1-Hour Design F-Rating:** 1 Hour, T-Rating: 3/4 Hour

**CAN/ULC S115**

**2-Hour Design FH Rating:** 2 Hour, FTH Rating: 1-1/4 Hour

**1-Hour Design FH Rating:** 1 Hour, FTH Rating: 3/4 Hour

**FEATURES & MATERIALS**

**Outlet Box & Brackets:** PVC

**Adapter:** PVC with 2" NPT Threads

**Box Connection:** PVC 1/4 Turn Adapter with Sealing Gasket

**Temperature Range:** -40° F/-40° C to 150° F/66° C

**DFU Rating:** 160 Branch, 24 Stack

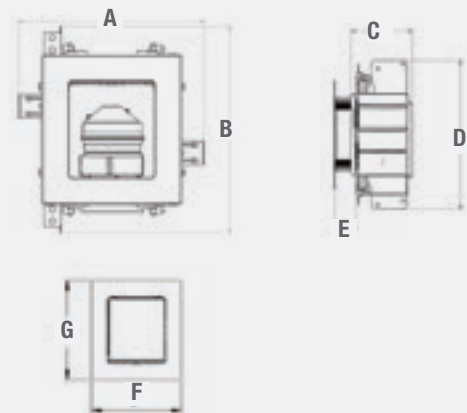

**DIMENSIONS**

**A:** Assembled Width 14.13"

**B:** Box Depth 3.38"

**C:** Box Height 4.85"

**D:** Bracket Width 4.00"

**E:** Bracket Length 8.00"

**F:** Faceplate Width 6.00"

**G:** Faceplate Height 6.45"

**H:** Faceplate Depth 1.25"



**Every Drain Needs a Trap. Every Trap Needs a Vent.**

To prevent sewer gases from being released into the structure, plumbing code states that a trap is required for all fixtures. A trap is designed to create a barrier between the structure and sewer system. Trap seals can only be compromised under two conditions — high sewer pressure and water siphonage, in both cases vents prevent this from happening.

Under high sewer pressures without a vent, trap seals will allow sewer gases to escape and enter the structure. This happens when the sewer pressure is greater than the pressure from the column of water in the trap. A vent will keep the sewer and atmospheric pressures equalized to maintain the trap seal.

Water moving through pipes can create a negative pressure or a siphon. The siphon will pull the water from a trap, leaving a clear path for sewer gases to enter the structure. A vent will prohibit siphoning, maintaining a trap seal.

**Why Use a Sure-Vent® Air Admittance Valve?**

Air Admittance Valves (AAVs) open and close in conjunction with normal DWV system operation, effectively eliminating the need for secondary vent pipes. An AAV provides an alternative to secondary venting when utilized within the scope of model plumbing codes, referenced standards and Oatey installation instructions.

AAVs provide the ideal venting solution for island sinks, remote bathroom groups and remodeling jobs by eliminating the need to tie into a stack vent.

AAVs are often more economical than installing vent pipe in new construction because they reduce the added need for materials and labor.

The Oatey Sure-Vent® offers UNMATCHED PERFORMANCE by opening and closing under the smallest pressures, multiple sizes for OPTIMIZED DFUs and SUPERIOR SEALING technology, providing a lifetime of reliability.

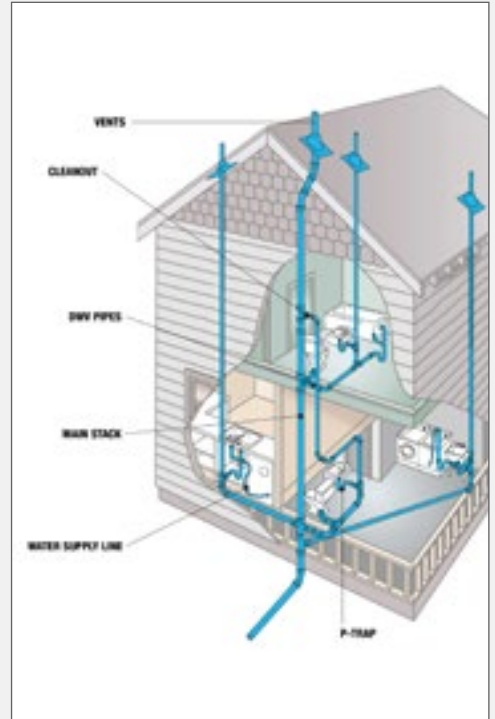

*Traditional Vented House*

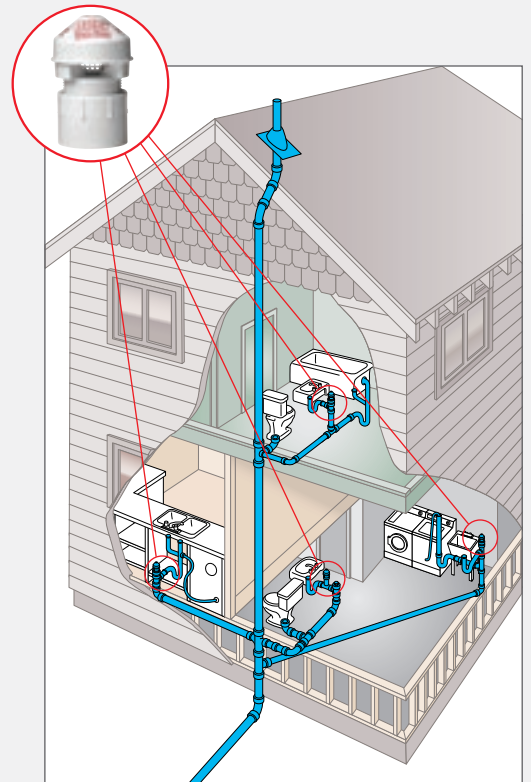

*AAV Vented House*



TWIST N SET

DONE RIGHT **FLANGES**

BATHROOM REMODEL

METAL

SECURE ATTACHMENT

SIMPLE INSTALL  
360° SWIVEL

TRUSTED

FAST SET

MOLDED-IN TEST CAP

ADDED STRENGTH

EASY CONNECTION

LOWER EXPENSE

PVC

ADJUSTABLE  
NO TOOLS NECESSARY

MINIMAL TIME

ELIMINATE LEAK PATHS

LEVELING

PRECISION SPIGOT FIT

MOSS BAY

**Oatey** COMMERCIAL

LEVEL FIT

STAINLESS STEEL

PREVENT CALLBACKS

BRASS

UPC TRUSTED

ABS

CAST IRON



# FLANGES

THE PART YOU NEED TO DO THE JOB RIGHT.

Oatey closet flanges come in a wide variety of sizes, materials and configurations. PVC, cast iron and ABS are all available in both open and testable versions.



## LEVEL FIT CLOSET FLANGE WITH PLASTIC 2 SLOT-2 SLIDE RING

### SPECIFICATIONS

Oatey Level Fit 2 Slot-2 Slide Ring Closet Flanges are designed to connect a water closet outlet to a plumbing system and sit flush with the floor. Oatey Level Fit 2 Slot-2 Slide Ring Closet Flanges solvent weld over 3" or inside 4" Sch. 40 DWV pipe.

- Flange with two mounting slots
- Countersunk screw holes provide secure attachment to floor
- Flange sits flush on floor
- Available with molded-in test cap

PRODUCT NO.	DESCRIPTION	CTN. QTY.
43528	3" or 4" ABS 2 Slot-2 Slide Ring Closet Flange, plastic ring with test cap	12
43529	3" or 4" PVC 2 Slot-2 Slide Ring Closet Flange, plastic ring with test cap	12
43530	3" or 4" ABS 2 Slot-2 Slide Ring Closet Flange, plastic ring without test cap	12
43531	3" or 4" PVC 2 Slot-2 Slide Ring Closet Flange, plastic ring without test cap	12



## LEVEL FIT LONG PATTERN

### SPECIFICATIONS

Oatey Level Fit Long Pattern Closet Flanges are designed to connect a water closet outlet to a plumbing system and sit flush with the floor. Oatey 3" or 4" Level Fit Closet Flanges solvent weld over 3" or inside 4" Sch 40 DWV pipe.

- Flange with two mounting slots
- Countersunk screw holes provide secure attachment to floor
- Flange sits flush on floor
- Available with molded-in test cap
- Longer length to allow for pipes cut short

PRODUCT NO.	DESCRIPTION	CTN. QTY.
43522	3" or 4" ABS Long Pattern Closet Flange, plastic ring with test cap	6
43523	3" or 4" PVC Long Pattern Closet Flange, plastic ring with test cap	6
43524	3" or 4" ABS Long Pattern Closet Flange, plastic ring without test cap	6
43525	3" or 4" PVC Long Pattern Closet Flange, plastic ring without test cap	6
43532	3" or 4" ABS Long Pattern Closet Flange, metal ring with test cap	6
43533	3" or 4" PVC Long Pattern Closet Flange, metal ring with test cap	6
43534	3" or 4" PVC Long Pattern Closet Flange w/ metal ring	6
43535	3" or 4" PVC Long Pattern Closet Flange w/ metal ring	6

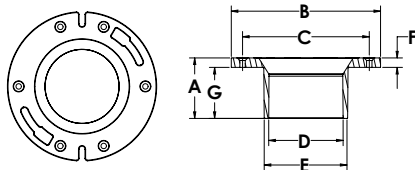

### APPROVALS & LISTINGS

**PVC Compliance Listing:** IAPMO Listing File #2896  
 Markings: UPC, cUPC, ASTM D 2665  
**ABS Compliance Listing:** IAPMO Listing File # 3905  
 Markings: UPC, cUPC, ASTM D 2661

### MATERIAL

**ABS Plastic:** Black  
**PVC Plastic:** White

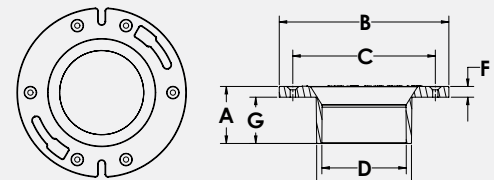

### LEVEL FIT CLOSET FLANGE WITH PLASTIC 2 SLOT-2 SLIDE RING DIMENSIONS

**A:** Overall Height 2.30"      **E:** Hub O.D. 4.00"  
**B:** Overall Diameter 7.00"      **F:** Flange Ring Thickness 0.40"  
**C:** Screw Centers 6.00"      **G:** Height 1.90"  
**D:** Hub I.D. 3.50"



### APPROVALS & LISTINGS

**PVC Compliance Listing:** IAPMO Listing File #2896  
 Markings: UPC, cUPC, ASTM D 2665  
**ABS Compliance Listing:** IAPMO Listing File # 3905  
 Markings: UPC, cUPC, ASTM D 2661

### MATERIAL

**ABS Plastic:** Black  
**PVC Plastic:** White  
**Metal Ring:** Painted

### LEVEL FIT LONG PATTERN FLANGE DIMENSIONS

**A:** Overall Height 2.90"      **E:** Hub O.D. 4.00"  
**B:** Overall Diameter 7.00"      **F:** Flange Ring Thickness 0.40"  
**C:** Screw Centers 6.00"      **G:** Height 2.40"  
**D:** Hub I.D. 3.50"



## LEVEL FIT CLOSET FLANGE WITH PLASTIC RING, LONG MOUNTING SLOTS

### SPECIFICATIONS

Oatey Level Fit Adjustable Closet Flanges are designed with four countersunk holes for secure attachment to the floor. Radial slots extend 130 degrees to allow exact alignment of the water closet. All plastic flange solvent welds over 3" or inside 4" Sch. 40 DWV pipe.

- Radial slots extend 130 degrees to allow exact alignment of water closet
- Available with molded in test cap

PRODUCT NO.	DESCRIPTION	CTN. QTY.
43510	3" or 4" ABS adjustable closet flange	12
43511	3" or 4" PVC adjustable closet flange	12
43526	3" or 4" ABS adjustable flange w/test cap	12
43527	3" or 4" PVC adjustable flange w/test cap	12

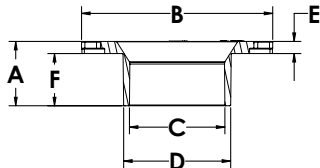
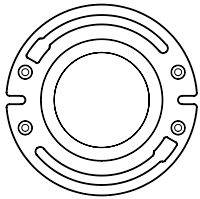

### APPROVALS & LISTINGS

**PVC Compliance Listing:** IAPMO Listing File #2896  
 Markings: UPC, cUPC, ASTM D 2665

**ABS Compliance Listing:** IAPMO Listing File #3905  
 Markings: UPC, cUPC, ASTM D 2661

### MATERIAL

**ABS Plastic:** Black  
**PVC Plastic:** White

### LEVEL FIT CLOSET FLANGE WITH PLASTIC RING DIMENSIONS

- A:** Overall Height 2.30"
- B:** Overall Diameter 7.00"
- C:** Hub i.D. 4.00"
- D:** Hub i.D. 4.00"
- E:** Flange Ring Thickness 0.40"
- F:** Height 1.90"



## LEVEL FIT OFFSET CLOSET FLANGES

### SPECIFICATIONS

Oatey Level Fit Offset Closet Flanges with Metal Ring are designed to connect a water closet outlet to a plumbing system and sit flush with the floor. 3" or 4" Level Fit Offset Closet Flange solvent welds over 3" Schedule 40 DWV pipe or inside 4" Schedule 40 DWV pipe.

- Designed with 2" offset to allow for a margin of error for drain pipe/flange alignment
- Metal ring provides added strength and cracking resistance to the flange and can be rotated to allow precise alignment of bolts and screws

PRODUCT NO.	DESCRIPTION	CTN. QTY.
43500	3" or 4" ABS Offset Closet Flange, metal ring	12
43501	3" or 4" PVC Offset Closet Flange, metal ring	12
43804	3" or 4" PVC Offset Closet Flange, metal ring	16
43605	3" or 4" PVC Offset Closet Flange W/ SS Ring	12
43606	3" or 4" ABS Offset Closet Flange W/ SS Ring	12

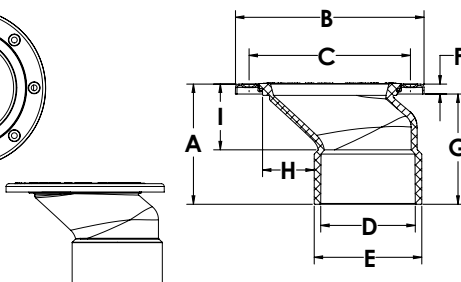
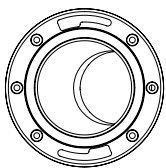

### APPROVALS & LISTINGS

**PVC Compliance Listing:** IAPMO Listing File #2896  
 Markings: UPC, cUPC, ASTM D 2665

**ABS Compliance Listing:** IAPMO Listing File # 3905  
 Markings: UPC, cUPC, ASTM D 2661

### MATERIAL

**ABS Plastic:** Black  
**PVC Plastic:** White  
**Stainless Steel Ring:** 400 Series  
**Metal Ring:** Painted

### LEVEL FIT OFFSET CLOSET FLANGE WITH METAL AND STAINLESS STEEL RINGS

- A:** Overall Height 4.47"
- B:** Overall Diameter 7.01"
- C:** Screw Center 6.00"
- D:** Hub ID 3.52"
- E:** Hub OD 4.0"
- F:** Flange Ring Thickness 0.37"
- G:** Depth 4.10"
- H:** Offset Distance 1.92"
- I:** Offset Distance 2.44"



## LEVEL FIT 45° CLOSET FLANGE

### SPECIFICATIONS

Oatey Level Fit 45 Degree Closet Flanges with Plastic or Stainless Steel Ring are designed for where clearance doesn't allow for normal flange installation. 3" or 4" Level Fit 45 degree closet flange solvent welds over 3" or inside 4" Sch. 40 DWV pipe.

- 45 Degree bend, 360 degree rotation allows wide range of plumbing connections in tight spaces
- Design allows flange to set flush

PRODUCT NO.	DESCRIPTION	CTN. QTY.
43815	3" or 4" ABS 45° Swivel Closet Flange	6
43816	3" or 4" PVC 45° Swivel Closet Flange	6
43607	3" or 4" PVC 45° Swivel Closet Flange w/SS Ring	12
43608	3" or 4" ABS 45° Swivel Closet Flange w/SS Ring	12

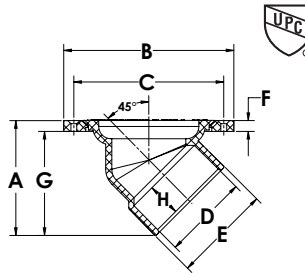
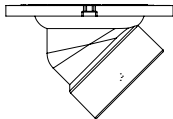
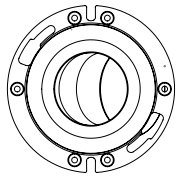

### APPROVALS & LISTINGS

**PVC Compliance Listing:** IAPMO Listing File #2896  
Markings: UPC, cUPC, ASTM D 2665

**ABS Compliance Listing:** IAPMO Listing File # 3905  
Markings: UPC, cUPC, ASTM D 2661

### MATERIAL

**ABS Plastic:** Black

**PVC Plastic:** White

**Stainless Steel Ring:** 400 Series

### LEVEL FIT 45° CLOSET FLANGE DIMENSIONS

- A:** Overall Height 4.70"      **F:** Flange Ring Thickness 0.45"  
**B:** Overall Diameter 6.97"      **G:** Depth 4.26"  
**C:** Screw Center 6.14"      **H:** Hub Depth 1.5"  
**D:** Hub ID 3.52"      **E:** Hub OD 4.0"  
**E:** Hub OD 4.0"



## CAST IRON CLOSET FLANGE

### SPECIFICATIONS

Oatey Cast Iron Closet Flanges are designed for use on plastic or heavy weight, no hub or service weight soil pipe. Does not require caulking. Comes complete with body, brass ring, bolts and gasket.

- Available with rubber cap

PRODUCT NO.	DESCRIPTION	CTN. QTY.
42253	3" Cast Iron Flange w/o test cap	6
42255	4" Cast Iron Flange w/o test cap	6
42256	4" Cast Iron Flange w/ test cap	6

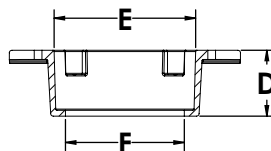
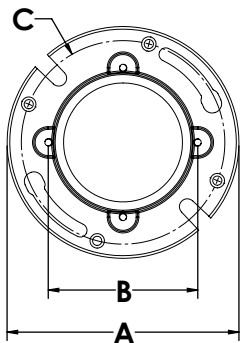

### MATERIAL

**Cast Iron:** Red

### 3" CAST IRON CLOSET FLANGE DIMENSIONS

- A:** Overall Diameter 6.9"      **D:** Overall Height 2.0"  
**B:** Screw Center 1 4.5"      **E:** Inner Dimension 1 4.2"  
**C:** Screw Center 2 6.1"      **F:** Inner Dimension 2 3.6"

### 4" CAST IRON CLOSET FLANGE DIMENSIONS

- A:** Overall Diameter 6.9"      **D:** Overall Height 2.0"  
**B:** Screw Center 1 5.5"      **E:** Inner Dimension 1 5.3"  
**C:** Screw Center 2 6.1"      **F:** Inner Dimension 2 4.7"



## CAST IRON DEEP SET CLOSET FLANGE

### SPECIFICATIONS

Oatey Deep Set Cast Iron Closet Flanges are designed for use on plastic or heavy weight, no hub or service weight soil pipe. Complete with body, brass ring, bolts and gasket.

- 4" Deep Set

PRODUCT NO.	DESCRIPTION	CTN. QTY.
42257	4" x 4" 165 Deep set cast iron closet flange	8



### MATERIAL

Cast Iron: Red

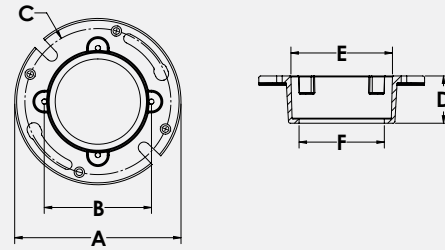

### CAST IRON DEEPSET CLOSET FLANGE DIMENSIONS

- A:** Overall Diameter 6.90"
- B:** Screw Center 1 5.50"
- C:** Screw Center 2 6.10"
- D:** Overall Height 3.40"
- E:** Inner Dimension 1 5.30"
- F:** Inner Dimension 2 Approx. 4.50"



## TWIST-N-SET® REPLACEMENT CLOSET FLANGE

### SPECIFICATIONS

Oatey Twist-N-Set Cast Iron Replacement Closet Flanges are designed to replace broken cast iron closet flanges. Gasket expands to fit inside of service weight, heavy weight and no hub pipe. Installs easily without tools.

PRODUCT NO.	DESCRIPTION	CTN. QTY.
43654	3" PVC Twist N Set Closet Flange	2
43655	3" ABS Twist N Set Closet Flange	2
43651	4" PVC Twist N Set Closet Flange	2
43650	4" ABS Twist N Set Closet Flange	2
43653	4" Cast Iron Twist N Set Closet Flange	2



### MATERIAL

ABS Plastic: Black  
PVC Plastic: White

### 3" TWIST-N-SET DIMENSIONS

- A:** Overall Height 3.88"
- B:** Overall Diameter 7.00"
- C:** Screw Center 6.0"
- D:** Hub Entrance ID 2.54"
- E:** Hub OD 2.89"
- F:** Hub ID 2.59"
- G:** Height 3.43"
- H:** Flange Ring Thickness 0.45"
- I:** Gasket OD (Bottom/Top) 2.86"/3.03"
- J:** Gasket Height 1.00"

### 4" TWIST-N-SET DIMENSIONS

- A:** Overall Height 3.36"
- B:** Overall Diameter 6.95"
- C:** Screw Center 6.0"
- D:** Hub Entrance ID 2.73"
- E:** Hub OD 3.75"
- F:** Hub ID 3.24"
- G:** Height 2.90"
- H:** Flange Ring Thickness 0.46"
- I:** Gasket OD 3.75"
- J:** Gasket Height 1.00"

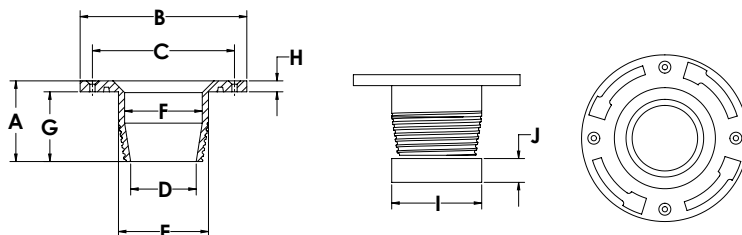



## REPLACEMENT CLOSET FLANGE

### SPECIFICATIONS

Oatey Cast Iron Closet Flange Replacement is designed for use to replace broken or corroded cast iron closet flanges. Flange slides easily into 4" cast iron piping with mechanical compression providing secure seal. Flange can be installed without tearing up the floor.

PRODUCT NO.	DESCRIPTION	CTN. QTY.
43538	4" ABS Closet Flange Replacement	12
43539	4" PVC Closet Flange Replacement	12



## CLOSET FLANGE SPACER

### SPECIFICATIONS

Oatey Closet Flange Spacers are designed to build up an existing closet flange when new flooring is installed and renders finished floor height below grade. Available in thickness of 1/4" or 1/2".

- Can be stacked to desired height

PRODUCT NO.	DESCRIPTION	CTN. QTY.
43519	1/4" Closet Flange Spacer	12
43646	1/2" Closet Flange Spacer	12



## HORIZONTAL ADJUSTABLE URINAL FLANGE KIT

### SPECIFICATIONS

Oatey's horizontal adjustable urinal mounting slots accommodates urinals with 3-1/2" to 7" mount centers. The flange fits over 2" Schedule 40 DWV pipe. Kit includes all bolts, nuts, washers and gaskets.

PRODUCT NO.	DESCRIPTION	CTN. QTY.
43540	2" ABS horizontal adjustable urinal flange kit	10
43541	2" PVC horizontal adjustable urinal flange kit	10
43542	2" ABS horizontal spigot urinal flange kit	10
43543	2" PVC horizontal spigot urinal flange kit	10

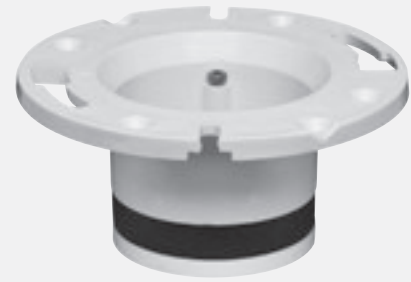
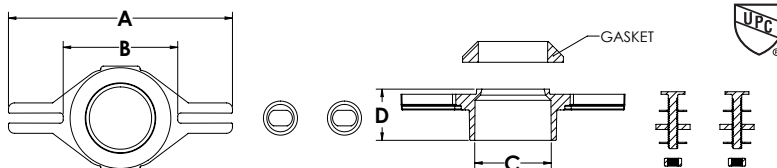

### MATERIAL

ABS Plastic: Black  
PVC Plastic: White

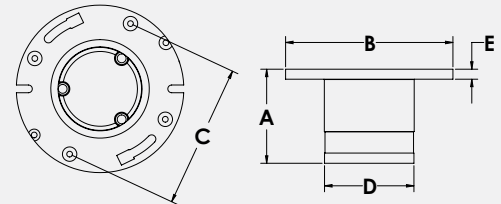

### REPLACEMENT CLOSET FLANGE DIMENSIONS

**A:** Overall Height 4.00"      **D:** Hub O.D. 3.70"  
**B:** Overall Diameter 6.90"      **E:** Flange Ring Thickness 0.40"  
**C:** Screw Centers 6.00"

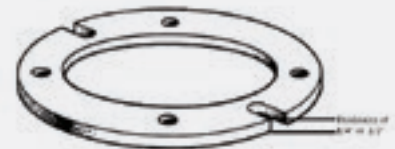

### APPROVALS & LISTINGS

IAPMO Listed

### MATERIAL

ABS Plastic: Black  
PVC Plastic: White

### HORIZONTAL ADJUSTABLE URINAL FLANGE KIT DIMENSIONS

**A:** Minimum Adjustable 7.00"      **C:** I.D. 2.40"  
**B:** Maximum Adjustable 3.60"      **D:** Height 1.60"



## STAINLESS STEEL CLOSET FLANGE REPLACEMENT RING

### SPECIFICATIONS

- For use on 3" or 4" closet flanges
- Six countersunk holes and two closet bolt slots for secure attachment to the floor

PRODUCT NO.	DESCRIPTION	CTN. QTY.
42778	3" or 4" Stainless Steel Closet Flange	12

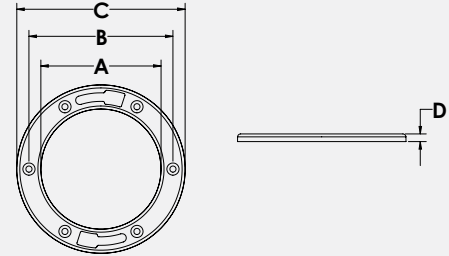

### STAINLESS STEEL CLOSET FLANGE REPLACEMENT RING DIMENSIONS

- A:** Ring ID 5.01"      **C:** Ring OD 7.01"  
**B:** Screw Center 6.00"      **D:** Overall Height 0.32"



## BRASS CLOSET FLANGE REPLACEMENT RING

### SPECIFICATIONS

- For use 4" closet flanges
- Three countersunk holes and three closet bolt slots for secure attachment to the floor

PRODUCT NO.	DESCRIPTION	CTN. QTY.
43551	3" or 4" Brass Closet Flange Replacement Ring	12



## METAL REPLACEMENT FLANGE

### SPECIFICATIONS

- For rusted or corroded metal closet flange rings
- For use on PVC or ABS closet flanges
- Includes closet bolts

PRODUCT NO.	DESCRIPTION	CTN. QTY.
42777	Replacement Flange	12

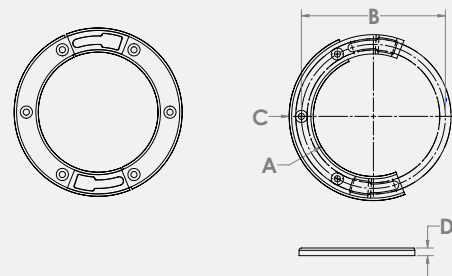

### MOSS BAY REPLACEMENT FLANGE DIMENSIONS

- A:** Ring ID 5.01"      **C:** Ring OD 7.01"  
**B:** Screw Center 6.00"      **D:** Overall Height 0.32"



#1 SOLVENT  
MANUFACTURER IN WORLD

**SOLVENT CEMENTS  
& PRIMERS**

EXPERT

INDUSTRIAL GRADE

PVC PIPE

LO-VOC

RAIN-R-SHINE

TRANSPARENT

HEAVY DUTY

REDUCED LABOR

LARGE FITTINGS

WET OR DRY CONDITIONS

VALUE ALL-TEMP

SUPERIOR BOND STRENGTH

EXCELLENCE

SET TIME

ANY APPLICATION

ADVANCED SEALING TECHNOLOGY  
COMMERCIAL APPLICATIONS

**Oatey** COMMERCIAL

CURE TIME

FAST CURING

NSF

ALL WEATHER

BROAD APPLICATION

SPECIALLY FORMULATED

PRESSURE SENSITIVITY

OATEY

EXCELLENCE

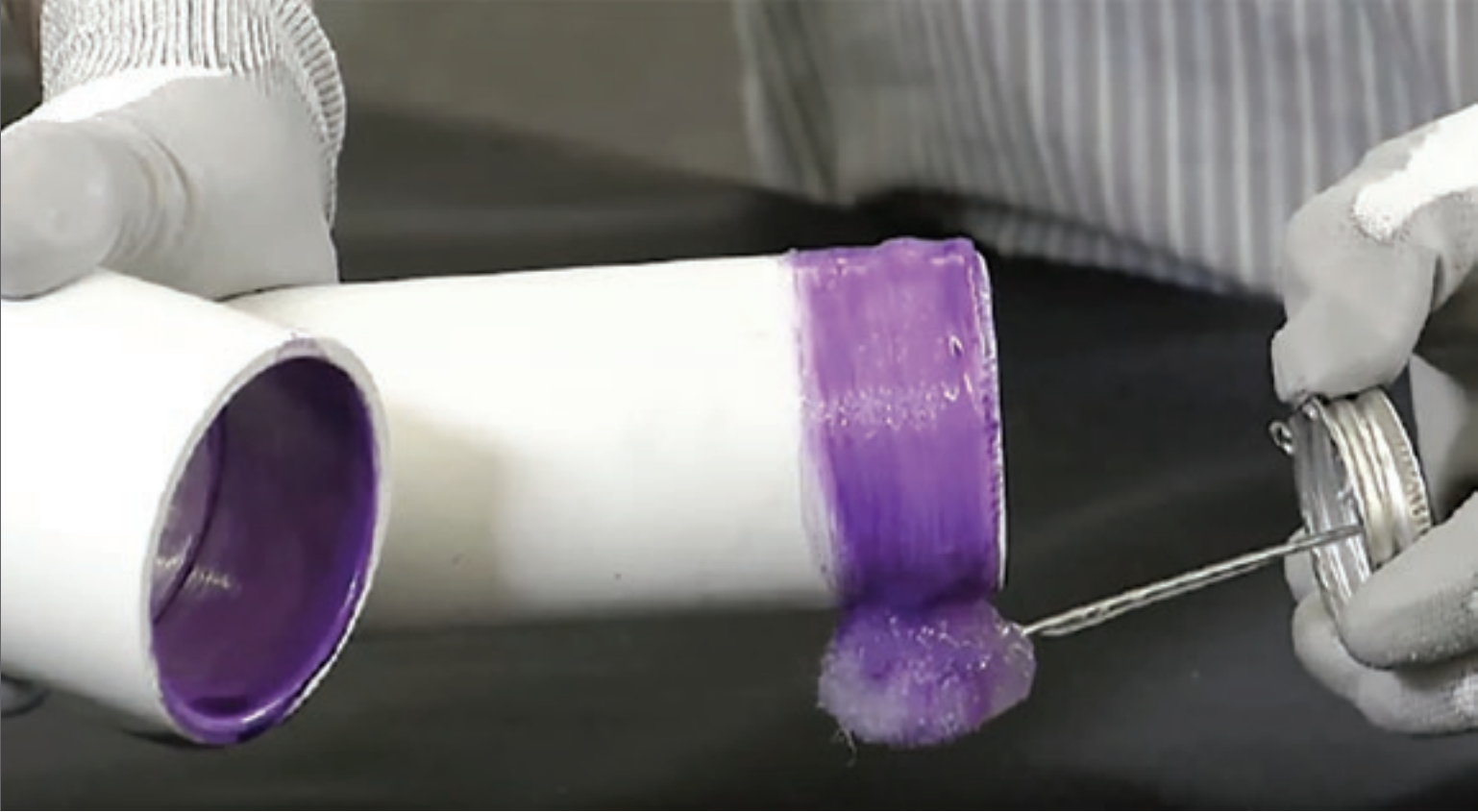

# SOLVENT CEMENTS & PRIMERS

**THE CHOICE OF PLUMBING PROFESSIONALS FOR NEARLY  
100 YEARS.**

Oatey® gives you more than just the strongest solvent welded joint – you get the confidence of the top-selling brands, backed by years of extensive research and leadership in the plumbing industry. That's why Oatey® has been the choice of plumbing professionals for nearly 100 years. Oatey® sells only Lo-VOC solvent cements, which means they are compliant with South Coast Air Quality Management District (SCAQMD) Rule 1168 and Ozone Transport Commission (OTC) standards. Plus they meet ASTM, NSF and UPC standards for a wide variety of applications, including potable water, DWV (drain, waste and vent), industrial, pool/spa, turf/irrigation, sewer and many more.

Oatey offers many products, as noted in this catalog that have achieved GREENGUARD Gold Certification (UL 2818 - 2013 Gold Standard for Chemical Emissions for Building Materials, Finishes and Furnishings). These products will satisfy LEED® V4 criteria while giving you multiple options. By virtue of achieving GREENGUARD Gold certification, these products also comply with California Department of Public Health "Standard Method for the Testing and Evaluation of Volatile Organic Chemical Emissions from Indoor Sources Using Environmental Chambers, Version 1.2" (CA Section 01350).



## PVC HEAVY DUTY CLEAR CEMENT

### SPECIFICATIONS

- Heavy bodied clear cement for use on all schedules and classes of PVC pipe and fittings up to 12" with interference fit, 18" for DWV applications.
- Lo-VOC Solvent Cement meets California South Coast Air Quality Management Districts (SCAQMD) 1168/316A or BAAQMD Method 40 requirements.
- Thick formula fills gaps in large diameter pipe and fitting joints.
- Recommended for potable water, pressure pipe, conduit and DWV applications.

PRODUCT NO.	SIZE	DESCRIPTION	CTN. QTY.
30850	4 oz.	PVC Heavy Duty Clear Cement	24
30863	8 oz.	PVC Heavy Duty Clear Cement	24
30876	16 oz.	PVC Heavy Duty Clear Cement	24
31008	32 oz.	PVC Heavy Duty Clear Cement	12
31011	Gallon	PVC Heavy Duty Clear Cement - Wide Mouth Can	6

### SET TIME / CURE TIME

- 30° F to 50° F:** 4 – 5 minutes  
**50° F to 70° F:** 3 – 4 minutes  
**70° F to 90° F:** 1 – 2 minutes



## PVC HEAVY DUTY GRAY CEMENT

### SPECIFICATIONS

- Heavy bodied gray cement for use on all schedules and classes of PVC pipe and fittings up to 12" diameter with interference fit, up to 18" for non-pressure.
- Lo-VOC Solvent Cement meets California South Coast Air Quality Management District (SCAQMD) 1168/316A or BAAQMD Method 40 and various environmental requirements.
- Thick formula fills gaps in large diameter pipe and fitting joints.
- Recommended for potable water, pressure pipe, conduit and DWV.

PRODUCT NO.	SIZE	DESCRIPTION	CTN. QTY.
31093	4 oz.	PVC Heavy Duty Gray Cement	24
31094	8 oz.	PVC Heavy Duty Gray Cement	24
31095	16 oz.	PVC Heavy Duty Gray Cement	24
31105	32 oz.	PVC Heavy Duty Gray Cement	12
31118	Gallon	PVC Heavy Duty Gray Cement - Wide Mouth Can	6

### SET TIME / CURE TIME

- 30° F to 50° F:** 6 – 7 minutes  
**50° F to 70° F:** 4 – 5 minutes  
**70° F to 90° F:** 1 – 3 minutes



### APPROVALS & LISTINGS

ASTM Standard D2564, NSF Standard 61 for PW, DWV and Sewer Waste, IAPMO Listed

**VOC:** Maximum VOC per SCAQMD 1168/316A or BAAQMD Method 40: 510 g/L

### CHEMICAL PROPERTIES

**Appearance:** Clear Liquid

**Viscosity:** Min. 1600° cps @ 73° F ± 2° F

**Density:** 7.86 ± 0.2 lbs/gallon

**Shelf Life:** 3 Years from Mfg. Date



### APPROVALS & LISTINGS

ASTM Standard D2564, NSF Standard 61 for PW, DWV and Sewer Waste, IAPMO Listed

**VOC:** Maximum VOC per SCAQMD 1168/316A or BAAQMD Method 40: 510 g/L

### CHEMICAL PROPERTIES

**Appearance:** Gray Liquid

**Viscosity:** Min. 1600° cps @ 73° F ± 2° F

**Density:** 7.86 ± 0.2 lbs/gallon

**Shelf Life:** 3 Years from Mfg. Date



## PVC MEDIUM CLEAR CEMENT

### SPECIFICATIONS

- Medium bodied clear cement for use on all schedules and classes of PVC pipe and fittings up to 6" diameter with interference fit.
- Lo-VOC Solvent Cement meets California South Coast Air Quality Management District (SCAQMD) 1168/316A or BAAQMD Method 40 and various environmental requirements.
- Recommended for potable water, pressure pipe, conduit and DWV.

PRODUCT NO.	SIZE	DESCRIPTION	CTN. QTY.
31017	4 oz.	PVC Medium Clear Cement	24
31018	8 oz.	PVC Medium Clear Cement	24
31019	16 oz.	PVC Medium Clear Cement	24
31020	32 oz.	PVC Medium Clear Cement	12
31021	Gallon	PVC Medium Clear Cement	6

### SET TIME / CURE TIME

30° F to 50° F: 5 – 6 minutes

50° F to 70° F: 3 – 4 minutes

70° F to 90° F: 1 – 2 minutes



### APPROVALS & LISTINGS

ASTM Standard D2564, NSF Standard 61 for PW, DWV and Sewer Waste, IAPMO Listed

**VOC:** Maximum VOC per SCAQMD 1168/316A or BAAQMD Method 40: 510 g/L

### CHEMICAL PROPERTIES

**Appearance:** Clear Liquid

**Viscosity:** Min. 500° cps @ 73° F ± 2° F

**Density:** 7.74 ± 0.2 lbs/gallon

**Shelf Life:** 3 Years from Mfg. Date



## PVC HEAVY DUTY GRAY FAST SET CEMENT

### SPECIFICATIONS

- Very heavy bodied medium setting gray cement for use on all schedules and classes of PVC pipe and fittings up to 18" diameter with interference fit.
- Lo-VOC Solvent Cement meets California South Coast Air Quality Management District (SCAQMD) 1168/316A or BAAQMD Method 40 and various environmental requirements.
- Formulated for a faster cure time so you can pressurize a system faster.
- Builds up for large diameter installations.
- Fills gaps in large diameter pipe and loose fitting joints.
- Recommended for potable water, pressure pipe, conduit and DWV.

PRODUCT NO.	SIZE	DESCRIPTION	CTN. QTY.
31121	16 oz.	PVC Heavy Duty Gray Fast Set Cement	24
31122	32 oz.	PVC Heavy Duty Gray Fast Set Cement	10
31123	Gallon	PVC Heavy Duty Gray Fast Set Cement - Wide Mouth Can	12

### SET TIME / CURE TIME

30° F to 50° F: 3 – 4 minutes

50° F to 70° F: 1 – 1/2" – 3 minutes

70° F to 90° F: 1 – 1/2" – 2 minutes



### APPROVALS & LISTINGS

ASTM Standard D2564, NSF Standard 61 for PW, DWV and Sewer Waste, IAPMO Listed

**VOC:** Maximum VOC per SCAQMD 1168/316A or BAAQMD Method 40: 510 g/L

### CHEMICAL PROPERTIES

**Appearance:** Gray Liquid

**Viscosity:** Min. 1600° cps @ 73° F ± 2° F

**Density:** 7.86 ± 0.2 lbs/gallon

**Shelf Life:** 3 Years from Mfg. Date



## PVC HEAVY DUTY MEDIUM SET GRAY CEMENT

### SPECIFICATIONS

- Very heavy bodied medium setting gray cement for use on all schedules and classes of PVC pipe and fittings up to 18" diameter with interference fit.
- Lo-VOC Solvent Cement meets California South Coast Air Quality Management District (SCAQMD) 1168/316A or BAAQMD Method 40 and various environmental requirements.
- Fills gaps in large diameter pipe and loose fitting joints.
- Recommended for potable water, pressure pipe, conduit and DWV.

PRODUCT NO.	SIZE	DESCRIPTION	CTN. QTY.
32262	16 oz.	Heavy Duty Medium Set Gray Cement	24
32263	32 oz.	Heavy Duty Medium Set Gray Cement	12
32264	Gallon	Heavy Duty Medium Set Gray Cement	6

### SET TIME / CURE TIME

30° F to 50° F: 4 – 5 minutes

50° F to 70° F: 2 – 3 minutes

70° F to 90° F: 1 – 2 minutes



### APPROVALS & LISTINGS

ASTM Standard D2564, NSF Standard 61 for PW, DWV and Sewer Waste, IAPMO Listed

**VOC:** Maximum VOC per SCAQMD 1168/316A or BAAQMD Method 40: 510 g/L

### CHEMICAL PROPERTIES

**Appearance:** Gray Liquid

**Viscosity:** Min. 2400° cps @ 73° F ± 2° F

**Density:** 7.86 ± 0.2 lbs/gallon

**Shelf Life:** 3 Years from Mfg. Date



## PVC MEDIUM GRAY CEMENT

### SPECIFICATIONS

- Medium bodied gray cement for use on all schedules and classes of PVC pipe and fittings up to 6" diameter with interference fit.
- Lo-VOC Solvent Cement meets California South Coast Air Quality Management District (SCAQMD) 1168/316A or BAAQMD Method 40 and various environmental requirements.
- Recommended for potable water, pressure pipe, conduit and DWV.

PRODUCT NO.	SIZE	DESCRIPTION	CTN. QTY.
30883	4 oz.	PVC Medium Gray Cement	24
30884	8 oz.	PVC Medium Gray Cement	24
30885	16 oz.	PVC Medium Gray Cement	24
30886	32 oz.	PVC Medium Gray Cement	12
30887	Gallon	PVC Medium Gray Cement	6

### SET TIME / CURE TIME

30° F to 50° F: 5 – 6 minutes

50° F to 70° F: 3 – 4 minutes

70° F to 90° F: 1 – 2 minutes



### APPROVALS & LISTINGS

ASTM Standard D2564, NSF Standard 61 for PW, DWV and Sewer Waste, IAPMO Listed

**VOC:** Maximum VOC per SCAQMD 1168/316A or BAAQMD Method 40: 510 g/L

### CHEMICAL PROPERTIES

**Appearance:** Gray Liquid

**Viscosity:** Min. 500° cps @ 73° F ± 2° F

**Density:** 7.74 ± 0.2 lbs/gallon

**Shelf Life:** 3 Years from Mfg. Date



## PVC REGULAR CLEAR CEMENT

### SPECIFICATIONS

- Regular bodied clear cement for use on all schedules and classes of PVC pipe and fittings up to 4" for Sch. 40 and up to 2" for Sch. 80.
- Lo-VOC Solvent Cement meets California South Coast Air Quality Management District (SCAQMD) 1168/316A or BAAQMD Method 40 and various environmental requirements.
- Recommended for potable water, pressure pipe, conduit and DWV.

PRODUCT NO.	SIZE	DESCRIPTION	CTN. QTY.
31012	4 oz.	PVC Regular Clear Cement	24
31013	8 oz.	PVC Regular Clear Cement	24
31014	16 oz.	PVC Regular Clear Cement	24
31015	32 oz.	PVC Regular Clear Cement	12
31016	Gallon	PVC Regular Clear Cement	6

### SET TIME / CURE TIME

30° F to 50° F: 5 – 6 minutes

50° F to 70° F: 3 – 4 minutes

70° F to 90° F: 1 – 2 minutes



### APPROVALS & LISTINGS

ASTM Standard D2564, NSF Standard 61 for PW, DWV and Sewer Waste, IAPMO Listed

**VOC:** Maximum VOC per SCAQMD 1168/316A or BAAQMD Method 40: 510 g/L

### CHEMICAL PROPERTIES

**Appearance:** Clear Liquid

**Viscosity:** Min. 90° cps @ 73° F ± 2° F

**Density:** 7.47 ± 0.2 lbs/gallon

**Shelf Life:** 3 Years from Mfg. Date



## PVC REGULAR CLEAR ADVANCED CEMENT

### SPECIFICATIONS

- Regular bodied clear cement for use on PVC pipe and fittings up to 4" for DWV Sch. 40 and up to 2" for Sch. 80.
- Lo-VOC Solvent Cement meets California South Coast Air Quality Management District (SCAQMD) 1168/316A or BAAQMD Method 40 and various environmental requirements.
- Sets up quickly.
- Recommended for potable water, pressure pipe, conduit and DWV.

PRODUCT NO.	SIZE	DESCRIPTION	CTN. QTY.
31925	4 oz.	PVC Regular Clear Advanced Cement	24
31926	8 oz.	PVC Regular Clear Advanced Cement	24
31927	16 oz.	PVC Regular Clear Advanced Cement	24
31928	32 oz.	PVC Regular Clear Advanced Cement	12
31929	Gallon	PVC Regular Clear Advanced Cement - Wide Mouth Can	6

### SET TIME / CURE TIME

30° F to 50° F: 6 – 7 minutes

50° F to 70° F: 4 – 5 minutes

70° F to 90° F: 1 – 3 minutes



### APPROVALS & LISTINGS

ASTM Standard D2564, NSF Standard 61 for PW, DWV and Sewer Waste, IAPMO Listed

**VOC:** Maximum VOC per SCAQMD 1168/316A or BAAQMD Method 40: 510 g/L

### CHEMICAL PROPERTIES

**Appearance:** Clear Liquid

**Viscosity:** Min. 90° cps @ 73° F ± 2° F

**Density:** 7.47 ± 0.2 lbs/gallon

**Shelf Life:** 3 Years from Mfg. Date



## PVC RAIN-R-SHINE® BLUE CEMENT

### SPECIFICATIONS

- Fast setting solvent cement formulated for quick pressurization in plumbing, irrigation and DWV applications.
- Formulated to provide a longer working time in hot conditions.
- Medium body blue cement for use on all schedules and classes of PVC pipe and fittings up to 6" diameter with interference fit.
- Lo-VOC Solvent Cement meets California South Coast Air Quality Management District (SCAQMD) 1168/316A or BAAQMD Method 40 and various environmental requirements.
- No primer needed where local code permits.
- Recommended for potable water, sewer, and DWV applications.
- Recommended application temperature 40°F to 110°F / 4°C to 43°C.

PRODUCT NO.	SIZE	DESCRIPTION	CTN. QTY.
30890	4 oz.	PVC Rain-R-Shine® Medium Blue Cement	24
30891	8 oz.	PVC Rain-R-Shine® Medium Blue Cement	24
30893	16 oz.	PVC Rain-R-Shine® Medium Blue Cement	24
30894	32 oz.	PVC Rain-R-Shine® Medium Blue Cement	12
30895	Gallon	PVC Rain-R-Shine® Medium Blue Cement – Wide Mouth Can	6

### SET TIME / CURE TIME

30° F to 50° F: 4 – 5 minutes

50° F to 70° F: 3 – 4 minutes

70° F to 90° F: 1 – 2 minutes



## HOT MEDIUM BLUE LAVA PVC CEMENT

### SPECIFICATIONS

- Extremely fast setting thick formula clings to pipe in wet and underwater applications.
- Preferred formula for emergency, repair, and cut in work.
- Medium bodied blue cement for use on all schedules and classes of PVC pipe and fittings up to 6" diameter with interference fit.
- Lo-VOC Solvent Cement meets California South Coast Air Quality Air Quality Management District (SCAQMD) 1168/316A or BAAQMD Method 40 and various environmental requirements.
- No primer needed where local code permits.
- Recommended for potable water, sewer, and DWV applications.
- Recommended application temperature 40°F to 110°F / 4°C to 43°C.

PRODUCT NO.	SIZE	DESCRIPTION	CTN. QTY.
32160	4 oz.	Hot Medium Blue Lava PVC Cement	24
32161	8 oz.	Hot Medium Blue Lava PVC Cement	24
32162	16 oz.	Hot Medium Blue Lava PVC Cement	24
32163	32 oz.	Hot Medium Blue Lava PVC Cement	12
32164	Gallon	Hot Medium Blue Lava PVC Cement	6

### SET TIME / CURE TIME

30° F to 50° F: 4 – 5 minutes

50° F to 70° F: 3 – 4 minutes

70° F to 90° F: 1 – 2 minutes



### APPROVALS & LISTINGS

ASTM Standard D2564, NSF Standard 61 for PW, DWV and Sewer Waste, IAPMO Listed

**VOC:** Maximum VOC per SCAQMD 1168/316A or BAAQMD Method 40: 510 g/L

### CHEMICAL PROPERTIES

**Appearance:** Blue Liquid

**Viscosity:** Min. 500° cps @ 73° F ± 2° F

**Density:** 7.83 ± 0.2 lbs/gallon

**Shelf Life:** 3 Years from Mfg. Date



### APPROVALS & LISTINGS

ASTM D2564

**VOC:** Maximum VOC per SCAQMD 1168/316A or BAAQMD Method 40: 510 g/L

### CHEMICAL PROPERTIES

**Appearance:** Blue Liquid

**Viscosity:** Min. 1500 cps @ 73° F ± 2° F

**Shelf Life:** 3 Years from Mfg. Date



## PVC ALL WEATHER CLEAR CEMENT

### SPECIFICATIONS

- Medium bodied clear cement for use on all schedules and classes of PVC pipe and fittings up to 6" diameter with interference fit.
- Lo-VOC Solvent Cement meets California South Coast Air Quality Management District (SCAQMD) 1168/316A or BAAQMD Method 40 and various environmental requirements.
- No primer needed on non-pressure DWV, where local codes permit.
- Recommended for use on potable water, drain, waste, and vent systems.
- Recommended application temperature -15°F to 110°F / -26°C to 43°C.

PRODUCT NO.	SIZE	DESCRIPTION	CTN. QTY.
31132	16 oz.	PVC All Weather Clear Cement	24
31133	32 oz.	PVC All Weather Clear Cement	12
31135	Gallon	PVC All Weather Clear Cement – Wide Mouth Can	6

### SET TIME / CURE TIME

30° F to 50° F: 3 – 4 minutes

50° F to 70° F: 2 – 3 minutes

70° F to 90° F: 1 – 2 minutes



PW-DWV-SW

SECOND GENERATION COMPLIANT



### APPROVALS & LISTINGS

ASTM Standard D2564, NSF Standard 61 for PW, DWV and Sewer Waste, IAPMO Listed

**VOC:** Maximum VOC per SCAQMD 1168/316A or BAAQMD Method 40: 510 g/L

### CHEMICAL PROPERTIES

**Appearance:** Clear Liquid

**Viscosity:** Min. 500° cps @ 73° F ± 2° F

**Density:** 7.89 ± 0.2 lbs/gallon

**Shelf Life:** 3 Years from Mfg. Date



## PVC FLEXIBLE CLEAR CEMENT

### SPECIFICATIONS

- Medium bodied clear cement for use on flexible PVC pipe and rigid fittings up to 6" diameter with interference fit.
- Lo-VOC Solvent Cement meets California South Coast Air Quality Management District (SCAQMD) 1168/316A or BAAQMD Method 40 and various environmental requirements.
- Meets manufacturer's rated line pressure for flexible PVC pipe.
- Formulated to withstand pressures and vibrations commonly associated with spa and swimming pool installations.

PRODUCT NO.	SIZE	DESCRIPTION	CTN. QTY.
30875	4 oz.	PVC Flexible Clear Cement	12
30879	32 oz.	PVC Flexible Clear Cement	12

### SET TIME / CURE TIME

30° F to 50° F: 4 – 5 minutes

50° F to 70° F: 3 – 4 minutes

70° F to 90° F: 1 – 2 minutes



PW-DWV-SW

SECOND GENERATION COMPLIANT



### APPROVALS & LISTINGS

ASTM Standard D2564, NSF Standard 61 for DWV and Sewer Waste, IAPMO Listed

**VOC:** Maximum VOC per SCAQMD 1168/316A or BAAQMD Method 40: 510 g/L

### CHEMICAL PROPERTIES

**Appearance:** Clear Liquid

**Viscosity:** Min. 500° cps @ 73° F ± 2° F

**Density:** 7.69 ± 0.2 lbs/gallon

**Shelf Life:** 3 Years from Mfg. Date





## EP42 CPVC HEAVY DUTY ORANGE INDUSTRIAL CEMENT

### SPECIFICATIONS

- Heavy bodied solvent cement formulated for use on PVC and CPVC piping systems requiring chemical resistance to caustics, including hypochlorite, mineral acids and aqueous salt solutions.
- Resistant to caustics and hypochlorites up to 15 percent solution. Refer to EP 42 Chemical Resistance Chart for compatibility prior to using with chemical solutions.
- For use with all CPVC materials including Corzan Industrial Piping Systems.
- Ultra violet indicator allows for quick and easy inspection of dry fit joints with any UV light source.
- Complies with various environmental requirements and SCAQMD Rule 1168/316A or BAAQMD Method 40 for VOC.

PRODUCT NO.	SIZE	DESCRIPTION	CTN. QTY.
30331	16 oz.	EP42 CPVC HD Orange Industrial Cement	24
30332	32 oz.	EP42 CPVC HD Orange Industrial Cement	12

### SET TIME / CURE TIME

30° F to 50° F: 4 – 5 minutes

50° F to 70° F: 2 – 3 minutes

70° F to 90° F: 1 – 2 minutes



PW-DWV-SW



### APPROVALS & LISTINGS

ASTM Standard F493

**VOC:** Maximum VOC per SCAQMD 1168/316A or BAAQMD Method 40: 490 g/L

### CHEMICAL PROPERTIES

**Appearance:** Orange Liquid

**Viscosity:** Min. 1600° cps @ 73° F ± 2° F

**Density:** 8.18 ± 0.2 lbs/gallon

**Shelf Life:** 2 Years from Mfg. Date



## EP42 CPVC HEAVY DUTY GRAY INDUSTRIAL CEMENT

### SPECIFICATIONS

- Heavy bodied solvent cement formulated for use on CPVC piping systems requiring chemical resistance to caustics, including hypochlorite, mineral acids and aqueous salt solutions.
- Resistant to caustics and hypochlorites up to 15 percent solution. Refer to EP 42 Chemical Resistance Chart for compatibility prior to using with chemical solutions.
- For use with all CPVC materials including Corzan® Industrial Piping Systems.
- Ultra violet indicator allows for quick and easy inspection of dry fit joints with any UV light source.
- Complies with various environmental requirements and SCAQMD Rule 1168/316A or BAAQMD Method 40 for VOC.
- Approved for Corzan® CPVC Piping Systems.

PRODUCT NO.	SIZE	DESCRIPTION	CTN. QTY.
30328	16 oz.	EP42 CPVC HD Gray Industrial Cement	24
30329	32 oz.	EP42 CPVC HD Gray Industrial Cement	12
30330	Gallon	EP42 CPVC HD Gray Industrial Cement	6

### SET TIME / CURE TIME

30° F to 50° F: 4 – 5 minutes

50° F to 70° F: 2 – 3 minutes

70° F to 90° F: 1 – 2 minutes



PW-DWV-SW



### APPROVALS & LISTINGS

ASTM Standard F493

**VOC:** Maximum VOC per SCAQMD 1168/316A or BAAQMD Method 40: 490 g/L

### CHEMICAL PROPERTIES

**Appearance:** Gray Liquid

**Viscosity:** Min. 1600° cps @ 73° F ± 2° F

**Density:** 8.18 ± 0.2 lbs/gallon

**Shelf Life:** 2 Years from Mfg. Date



## ALL WEATHER CPVC FLOWGUARD GOLD®\* 1-STEP YELLOW CEMENT

### SPECIFICATIONS

- For copper tube size (CTS) CPVC hot and cold potable water pipe and fittings up to 2" diameter interference fit.
- Lo-VOC Solvent Cement meets California South Coast Air Quality Management District (SCAQMD) 1168/316A or BAAQMD Method 40 and various environmental requirements.
- May be used without primer where local codes permit.
- For cold water systems and hot water systems up to 200°F / 93°C.

\*FlowGuard Gold is a registered trademark of The Lubrizol Corporation.

PRODUCT NO.	SIZE	DESCRIPTION	CTN. QTY.
31910	4 oz.	CPVC Flowguard Gold® 1-Step Yellow Cement	24
31911	8 oz.	CPVC Flowguard Gold® 1-Step Yellow Cement	24
31912	16 oz.	CPVC Flowguard Gold® 1-Step Yellow Cement	24
31913	32 oz.	CPVC Flowguard Gold® 1-Step Yellow Cement	12
31914	Gallon	CPVC Flowguard Gold® 1-Step Yellow Cement	6

### SET TIME / CURE TIME

30° F to 50° F: 4 – 5 minutes

50° F to 70° F: 2 – 3 minutes

70° F to 90° F: 1 – 2 minutes



### APPROVALS & LISTINGS

ASTM F493, NSF Standard 61 for DWV and Sewer Waste, IAPMO Listed

**VOC:** Maximum VOC per SCAQMD 1168/316A or BAAQMD Method 40: 490 g/L

### CHEMICAL PROPERTIES

**Appearance:** Yellow Liquid

**Viscosity:** Min. 500° cps @ 73° F ± 2° F

**Density:** 7.98 ± 0.2 lbs/gallon

**Shelf Life:** 2 Years from Mfg. Date



## ALL WEATHER 1-STEP FLOWGUARD GOLD®\* WITH ULTRAVIOLET INDICATOR

### SPECIFICATIONS

- For copper tube size (CTS) CPVC hot and cold potable water pipe and fittings up to 2" diameter interference fit.
- Lo-VOC Solvent Cement meets California South Coast Air Quality Management District (SCAQMD) 1168/316A or BAAQMD Method 40 and various environmental requirements.
- CPVC FlowGuard Gold® with UltraViolet Indicator is specially formulated to allow for quick and easy inspection of dry fit joints using any ultraviolet light source.
- When solvent cement is applied properly, the yellow formula will glow BLUE under ultraviolet light.
- May be used without primer where local codes permit.
- For cold water systems and hot water systems up to 200°F / 93°C.

\*FlowGuard Gold is a registered trademark of The Lubrizol Corporation.

PRODUCT NO.	SIZE	DESCRIPTION	CTN. QTY.
31917	8 oz.	1-Step CPVC Flowguard Gold® Cement with UV Indicator	24
31918	16 oz.	1-Step CPVC Flowguard Gold® Cement with UV Indicator	24
31919	32 oz.	1-Step CPVC Flowguard Gold® Cement with UV Indicator	12

### SET TIME / CURE TIME

30° F to 50° F: 4 – 5 minutes

50° F to 70° F: 2 – 3 minutes

70° F to 90° F: 1 – 2 minutes



### APPROVALS & LISTINGS

ASTM F493, NSF Standard 61 for PW, DWV and Sewer Waste, IAPMO Listed

**VOC:** Maximum VOC per SCAQMD 1168/316A or BAAQMD Method 40: 490 g/L

### CHEMICAL PROPERTIES

**Appearance:** Yellow Liquid

**Viscosity:** Min. 500° cps @ 73° F ± 2° F

**Density:** 7.98 ± 0.2 lbs/gallon

**Shelf Life:** 2 Years from Mfg. Date



## CPVC MEDIUM ORANGE CEMENT

### SPECIFICATIONS

- Medium bodied orange cement for use on all schedules and classes of CPVC pipe and fittings up to 6" diameter with interference fit.
- Lo-VOC Solvent Cement meets California South Coast Air Quality Management District (SCAQMD) 1168/316A or BAAQMD Method 40 and various environmental requirements.
- Approved for Corzan®\* CPVC Piping Systems.
- For Commercial hot and cold water systems up to 200°F / 93°C.

\*Corzan is a registered trademark of The Lubrizol Corporation.

PRODUCT NO.	SIZE	DESCRIPTION	CTN. QTY.
31128	4 oz.	CPVC Medium Orange Cement	24
31129	8 oz.	CPVC Medium Orange Cement	24
31130	16 oz.	CPVC Medium Orange Cement	24
31131	32 oz.	CPVC Medium Orange Cement	12
31127	Gallon	CPVC Medium Orange Cement	6

### SET TIME / CURE TIME

30° F to 50° F: 4 – 5 minutes

50° F to 70° F: 2 – 3 minutes

70° F to 90° F: 1 – 2 minutes



### APPROVALS & LISTINGS

ASTM F493, NSF Standard 61 for PW, DWV and Sewer Waste, IAPMO Listed

**VOC:** Maximum VOC per SCAQMD 1168/316A or BAAQMD Method 40: 490 g/L

### CHEMICAL PROPERTIES

**Appearance:** Orange Liquid

**Viscosity:** Min. 500° cps @ 73° F ± 2° F

**Density:** 7.99 ± 0.2 lbs/gallon

**Shelf Life:** 2 Years from Mfg. Date



## CPVC HEAVY DUTY ORANGE CEMENT

### SPECIFICATIONS

- Heavy bodied orange cement for use on all schedules and classes of CPVC pipe and fittings up to 12" diameter with interference fit.
- Lo-VOC Solvent Cement meets California South Coast Air Quality Management District (SCAQMD) 1168/316A or BAAQMD Method 40 and various environmental requirements.
- Approved for Corzan®\* CPVC Piping Systems.
- For Commercial hot and cold water systems up to 200°F / 93°C.

\*Corzan is a registered trademark of The Lubrizol Corporation.

PRODUCT NO.	SIZE	DESCRIPTION	CTN. QTY.
31082	16 oz.	CPVC Heavy Duty Orange Cement	24
31083	32 oz.	CPVC Heavy Duty Orange Cement	12
31084	Gallon	CPVC Heavy Duty Orange Cement – Wide Mouth Can	6

### SET TIME / CURE TIME

30° F to 50° F: 4 – 5 minutes

50° F to 70° F: 2 – 3 minutes

70° F to 90° F: 1 – 2 minutes



### APPROVALS & LISTINGS

ASTM F493, NSF Standard 61 for DWV and Sewer Waste, IAPMO Listed

**VOC:** Maximum VOC per SCAQMD 1168/316A or BAAQMD Method 40: 490 g/L

### CHEMICAL PROPERTIES

**Appearance:** Orange Liquid

**Viscosity:** Min. 1600° cps @ 73° F ± 2° F

**Density:** 8.05 ± 0.2 lbs/gallon

**Shelf Life:** 2 Years from Mfg. Date



## CPVC HEAVY DUTY GRAY CEMENT

### SPECIFICATIONS

- Heavy bodied gray cement for use on all schedules and classes of CPVC pipe and fittings up to 12" diameter with interference fit.
- Lo-VOC Solvent Cement meets California South Coast Air Quality Management District (SCAQMD) 1168/316A or BAAQMD Method 40 and various environmental requirements.
- Approved for Corzan®\* CPVC Piping Systems.
- For Commercial hot and cold water systems up to 200°F / 93°C.

\*Corzan is a registered trademark of The Lubrizol Corporation.

PRODUCT NO.	SIZE	DESCRIPTION	CTN. QTY.
31036	16 oz.	CPVC Heavy Duty Gray Cement	24
31037	32 oz.	CPVC Heavy Duty Gray Cement	12

### SET TIME / CURE TIME

30° F to 50° F: 4 – 5 minutes

50° F to 70° F: 2 – 3 minutes

70° F to 90° F: 1 – 2 minutes



### APPROVALS & LISTINGS

ASTM F493, NSF Standard 61 for PW, DWV and Sewer Waste, IAPMO Listed

**VOC:** Maximum VOC per SCAQMD 1168/316A or BAAQMD Method 40: 490 g/L

### CHEMICAL PROPERTIES

**Appearance:** Gray Liquid

**Viscosity:** Min. 1600° cps @ 73° F ± 2° F

**Density:** 8.05 ± 0.2 lbs/gallon

**Shelf Life:** 2 Years from Mfg. Date



## CPVC HEAVY DUTY ORANGE LAVA CEMENT

### SPECIFICATIONS

- Heavy bodied orange cement for use on all schedules and classes of CPVC pipe and fittings up to 12" diameter with interference fit. Formulated for repair and cut-in work.
- Lo-VOC Solvent Cement meets California South Coast Air Quality Management District (SCAQMD) 1168/316A or BAAQMD Method 40 and various environmental requirements.
- Approved for Corzan®\* CPVC Piping Systems.
- For Commercial hot and cold water systems up to 200°F / 93°C.

PRODUCT NO.	SIZE	DESCRIPTION	CTN. QTY.
32166	8 oz.	Heavy Duty Orange PVC Cement	24
32167	16 oz.	Heavy Duty Orange PVC Cement	24
32168	32 oz.	Heavy Duty Orange PVC Cement	12

### SET TIME / CURE TIME

30° F to 50° F: 4 – 5 minutes

50° F to 70° F: 3 – 4 minutes

70° F to 90° F: 1 – 2 minutes



### APPROVALS & LISTINGS

ASTM F493, NSF Standard 61 for PW, DWV and Sewer Waste, IAPMO Listed

**VOC:** Maximum VOC per SCAQMD 1168/316A or BAAQMD Method 40: 490 g/L

### CHEMICAL PROPERTIES

**Appearance:** Orange Liquid

**Viscosity:** Min. 1600° cps @ 73° F ± 2° F

**Density:** 8.05 ± 0.2 lbs/gallon

**Shelf Life:** 2 Years from Mfg. Date



## ABS TO PVC TRANSITION GREEN CEMENT

### SPECIFICATIONS

- Oatey ABS to PVC Transition Green Solvent Cement is recommended for solvent welding non-pressure ABS to non-pressure PVC pipe and fittings up to 6" diameter.
- This product is compliant with California South Coast Air Quality Management District (SCAQMD) Rule 1168 and Ozone Transport Commission (OTC) regulations for Volatile Organic Compound emission levels.
- This product is not for use in a system using or being tested by compressed air or gases.
- Some plumbing codes prohibit chemically joining (solvent weld) dissimilar materials (ABS/PVC). Verify with local building officials that the use of Transition Cement is permitted.
- ABS to PVC Transition Green Solvent Cement can be used for sewer and drain, waste and vent systems.

PRODUCT NO.	SIZE	DESCRIPTION	CTN. QTY.
30900	4 oz.	ABS To PVC Transition Green Cement	24
30925	16 oz.	ABS To PVC Transition Green Cement	6
30926	32 oz.	ABS To PVC Transition Green Cement	12

### SET TIME / CURE TIME

30° F to 50° F: 5 – 6 minutes

50° F to 70° F: 3 – 4 minutes

70° F to 90° F: 1 – 2 minutes



### APPROVALS & LISTINGS

ASTM D3148, NSF Standard 61 for DWV and Sewer Waste, IAPMO Listed

**VOC:** Maximum VOC per SCAQMD 1168/316A or BAAQMD Method 40: 510 g/L

### CHEMICAL PROPERTIES

**Appearance:** Green Liquid

**Viscosity:** Min. 1000° cps @ 73° F ± 2° F

**Density:** 7.74 ± 0.2 lbs/gallon

**Shelf Life:** 3 Years from Mfg. Date



## ABS MEDIUM BLACK CEMENT

### SPECIFICATIONS

- Medium bodied black cement for use on all schedules and classes of ABS pipe and fittings up to 6" diameter with interference fit.
- Lo-VOC Solvent Cement meets California South Coast Air Quality Management District (SCAQMD) 1168/316A or BAAQMD Method 40 and various environmental requirements.
- For all non-pressure applications.

PRODUCT NO.	SIZE	DESCRIPTION	CTN. QTY.
30999	4 oz.	ABS Medium Black Cement	24
30889	8 oz.	ABS Medium Black Cement	24
30892	16 oz.	ABS Medium Black Cement	24
30902	32 oz.	ABS Medium Black Cement	12
30915	Gallon	ABS Medium Black Cement	6

### SET TIME / CURE TIME

30° F to 50° F: 5 – 6 minutes

50° F to 70° F: 3 – 4 minutes

70° F to 90° F: 1 – 2 minutes



### APPROVALS & LISTINGS

ASTM D2235, NSF Standard 61 for DWV and Sewer Waste, IAPMO Listed

**VOC:** Maximum VOC per SCAQMD 1168/316A or BAAQMD Method 40: 325 g/L

### CHEMICAL PROPERTIES

**Appearance:** Black Liquid

**Viscosity:** Min. 500° cps @ 73° F ± 2° F

**Density:** 7.42 ± 0.2 lbs/gallon

**Shelf Life:** 3 Years from Mfg. Date



## ABS SPECIAL MILKY CLEAR CEMENT

### SPECIFICATIONS

- Oatey Special Medium Milky Clear Solvent Cement is recommended for solvent welding non-pressure ABS pipe and fittings up to 6" with interference fit.
- ABS Solvent Cement applies milky in color and dries clear making it ideal for finish work.
- This product is compliant with California South Coast Air Quality Management District (SCAQMD) Rule 1168 and Ozone Transport Commission (OTC) regulations for Volatile Organic Compound emission levels.
- This product is not for use in a system using or being tested by compressed air or gases.
- ABS Solvent Cement can be used for sewer and drain, waste and vent systems.

PRODUCT NO.	SIZE	DESCRIPTION	CTN. QTY.
30922	16 oz.	ABS Special Milky Clear Cement	24
30923	32 oz.	ABS Special Milky Clear Cement	12
30924	Gallon	ABS Special Milky Clear Cement	6

### SET TIME / CURE TIME

- 30° F to 50° F: 6 – 7 minutes
- 50° F to 70° F: 5 – 6 minutes
- 70° F to 90° F: 1 – 2 minutes



### APPROVALS & LISTINGS

ASTM D2235, NSF Standard 61 for DWV and Sewer Waste, IAPMO Listed

**VOC:** Maximum VOC per SCAQMD 1168/316A or BAAQMD Method 40: 325 g/L

### CHEMICAL PROPERTIES

**Appearance:** Milky Clear Liquid

**Viscosity:** Min. 500° cps @ 73° F ± 2° F

**Density:** 7.39 ± 0.2 lbs/gallon

**Shelf Life:** 3 Years from Mfg. Date



## ABS EXTRA SPECIAL BLACK CEMENT

### SPECIFICATIONS

- Medium bodied black cement for use on all schedules and classes of ABS pipe and fittings up to 6" diameter with interference fit.
- Lo-VOC Solvent Cement meets California South Coast Air Quality Management District (SCAQMD) 1168/316A or BAAQMD Method 40 and various environmental requirements.
- Formulated especially for the hot, arid climates in the Western states.
- For all non-pressure applications.

PRODUCT NO.	SIZE	DESCRIPTION	CTN. QTY.
30916	4 oz.	ABS Extra Special Black Cement	24
30917	8 oz.	ABS Extra Special Black Cement	24
30918	16 oz.	ABS Extra Special Black Cement	24
30919	32 oz.	ABS Extra Special Black Cement	12
30920	Gallon	ABS Extra Special Black Cement	6

### SET TIME / CURE TIME

- 30° F to 50° F: 6 – 7 minutes
- 50° F to 70° F: 5 – 6 minutes
- 70° F to 90° F: 1 – 2 minutes



### APPROVALS & LISTINGS

ASTM D2235, NSF Standard 61 for DWV and Sewer Waste, IAPMO Listed

**VOC:** Maximum VOC per SCAQMD 1168/316A or BAAQMD Method 40: 325 g/L

### CHEMICAL PROPERTIES

**Appearance:** Black Liquid

**Viscosity:** Min. 500° cps @ 73° F ± 2° F

**Density:** 7.26 ± 0.2 lbs/gallon

**Shelf Life:** 3 Years from Mfg. Date



## INDUSTRIAL GRADE PURPLE PRIMER – NSF LISTED

### SPECIFICATIONS

- Very Aggressive Purple-tinted primer for use on PVC and CPVC pipe and fittings.
- Lo-VOC Solvent Cement meets California South Coast Air Quality Management District (SCAQMD) 1168/316A or BAAQMD Method 40 and various environmental requirements.
- Recommended for Commercial and large diameter thermoplastic piping systems, specifically CPVC Sch. 40 / 80.
- Ideal for use in cold weather applications.
- Removes surface dirt, grease and grime as well as softens the pipe surface to allow a fast, secure solvent weld.
- For use in areas where plumbing code calls for verification that a primer has been used.

PRODUCT NO.	SIZE	DESCRIPTION	CTN. QTY.
30770	16 oz.	Purple Primer – Industrial Grade	24
30771	32 oz.	Purple Primer – Industrial Grade	12
30772	Gallon	Purple Primer – Industrial Grade	6



### APPROVALS & LISTINGS

ASTM F656, NSF Standard 61 for PW, DWV and Sewer Waste, IAPMO Listed

**VOC:** Maximum VOC per SCAQMD 1168/316A or BAAQMD Method 40: 550 g/L

### CHEMICAL PROPERTIES

**Appearance:** Purple Liquid

**Density:** 7.15 ± 0.2 lbs/gallon

**Shelf Life:** 3 Years from Mfg. Date



## PURPLE PRIMER – NSF LISTED

### SPECIFICATIONS

- Purple-tinted aggressive primer for use on PVC and CPVC pipe and fittings.
- Lo-VOC Solvent Cement meets California South Coast Air Quality Management District (SCAQMD) 1168/316A or BAAQMD Method 40 and various environmental requirements.
- Removes surface dirt, grease and grime as well as softens the pipe surface to allow a fast, secure solvent weld.
- For use in areas where plumbing code calls for verification that a primer has been used.

PRODUCT NO.	SIZE	DESCRIPTION	CTN. QTY.
30755	4 oz.	Purple Primer	24
30756	8 oz.	Purple Primer	24
30757	16 oz.	Purple Primer	24
30758	32 oz.	Purple Primer	12
30759	Gallon	Purple Primer – Wide Mouth Can	6



### APPROVALS & LISTINGS

ASTM F656, NSF Standard 61 for PW, DWV and Sewer Waste, IAPMO Listed

**VOC:** Maximum VOC per SCAQMD 1168/316A or BAAQMD Method 40: 550 g/L

### CHEMICAL PROPERTIES

**Appearance:** Purple Liquid

**Density:** 6.97 ± 0.2 lbs/gallon

**Shelf Life:** 3 Years from Mfg. Date



## INDUSTRIAL GRADE CLEAR PRIMER – NSF LISTED

### SPECIFICATIONS

- Aggressive clear primer for use on PVC and CPVC pipe and fittings in industrial applications.
- Lo-VOC Solvent Cement meets California South Coast Air Quality Management District (SCAQMD) 1168/316A or BAAQMD Method 40 and various environmental requirements.
- Removes surface dirt, grease and grime as well as softens the pipe surface to allow a fast, secure solvent weld
- Ideal for use in cold weather applications.
- Recommended for Commercial and large diameter thermoplastic piping systems, specifically CPVC Sch. 40 / 80.

PRODUCT NO.	SIZE	DESCRIPTION	CTN. QTY.
30773	16 oz.	Clear Primer – Industrial Grade	24
30774	32 oz.	Clear Primer – Industrial Grade	12
30775	Gallon	Clear Primer – Industrial Grade	6



### APPROVALS & LISTINGS

ASTM F656, NSF Standard 61 for PW, DWV and Sewer Waste, IAPMO Listed

**VOC:** Maximum VOC per SCAQMD 1168/316A or BAAQMD Method 40: 550 g/L

### CHEMICAL PROPERTIES

**Appearance:** Clear Primer

**Density:** 7.15 ± 0.2 lbs/gallon

**Shelf Life:** 3 Years from Mfg. Date



## CLEAR PRIMER – NSF LISTED

### SPECIFICATIONS

- Clear aggressive primer for use on PVC and CPVC pipe and fittings.
- Lo-VOC Solvent Cement meets California South Coast Air Quality Management District (SCAQMD) 1168/316A or BAAQMD Method 40 and various environmental requirements.
- Removes surface dirt, grease and grime as well as softens the pipe surface to allow a fast, secure solvent weld.

PRODUCT NO.	SIZE	DESCRIPTION	CTN. QTY.
30750	4 oz.	Clear Primer	24
30751	8 oz.	Clear Primer	24
30752	16 oz.	Clear Primer	24
30753	32 oz.	Clear Primer	12
30754	Gallon	Clear Primer	6



### APPROVALS & LISTINGS

ASTM F656, NSF Standard 61 for PW, DWV and Sewer Waste, IAPMO Listed

**VOC:** Maximum VOC per SCAQMD 1168/316A or BAAQMD Method 40: 550 g/L

### CHEMICAL PROPERTIES

**Appearance:** Clear Primer

**Density:** 6.97 ± 0.2 lbs/gallon

**Shelf Life:** 3 Years from Mfg. Date





## PURPLE PRIMER CLEANER

### SPECIFICATIONS

- Purple-tinted primer for use on PVC and CPVC pipe and fittings.
- Lo-VOC Solvent Cement meets California South Coast Air Quality Management District (SCAQMD) 1171/M24 or BAAQMD Method 40 and various environmental requirements.
- Less aggressive than clear and purple primers.
- Always check local codes for acceptability of this product.
- Removes surface dirt, grease and grime for preparation before solvent cementing.

PRODUCT NO.	SIZE	DESCRIPTION	CTN. QTY.
30780	4 oz.	Purple Primer/Cleaner	24
30783	8 oz.	Purple Primer/Cleaner	24
30796	16 oz.	Purple Primer/Cleaner	24
30806	32 oz.	Purple Primer/Cleaner	12
30768	Gallon	Purple Primer/Cleaner	6



**VOC:** Maximum VOC < 25 g/L per SCAQMD 1171/EPA Method 24 or BAAQMD Method 40: 550 g/L

### CHEMICAL PROPERTIES

**Appearance:** Purple Liquid

**Density:** 6.18 ± 0.2 lbs/gallon

**Shelf Life:** 3 Years from Mfg. Date



## CLEAR CLEANER

### SPECIFICATIONS

- Clear Cleaner for ABS, PVC and CPVC pipe and fittings.
- Lo-VOC Solvent Cement meets California South Coast Air Quality Management District (SCAQMD) 1171/M24 or BAAQMD Method 40 and various environmental requirements.
- All schedules and all diameters.
- Flows freely and evaporates quickly.
- Fast acting cleaner removes surface dirt, grease and grime.

PRODUCT NO.	SIZE	DESCRIPTION	CTN. QTY.
30779	4 oz.	Cleaner	24
30782	8 oz.	Cleaner	24
30795	16 oz.	Cleaner – Display Pack	24
30805	32 oz.	Cleaner	12
30766	Gallon	Cleaner – Wide Mouth Can	6



**VOC:** Maximum VOC < 25 g/L per SCAQMD 1171/EPA Method 24 or BAAQMD Method 40: 550 g/L

### CHEMICAL PROPERTIES

**Appearance:** Clear Liquid

**Density:** 6.62 ± 0.2 lbs/gallon

**Shelf Life:** 3 Years from Mfg. Date



Oatey solvent cement and primer products are now certified to UL Greenguard Gold!



## UL GREENGUARD GOLD CERTIFIED, LEED CONTRIBUTING PRODUCTS

We are excited to announce that Oatey solvent cement and primer products are now certified to UL Greenguard Gold!

Oatey is the **only solvent cement manufacturer to obtain this certification!** This puts our cements and primers in a winning position for jobs and specs where LEED Building Certification is a focus.

### This certification signifies:

- When used in a job, UL Greenguard Gold listed products can provide you with LEED points
- These products have been certified by UL for compliance with UL 2818-2013, Gold Standard for Chemical Emissions for Building Materials, Finishes and Furnishings. For more information visit <https://www.ul.com/resources/ul-greenguard-certification-program>
- These products comply with California Department of Public Health “Standard Method for the Testing and Evaluation of Volatile Organic Chemical Emissions from Indoor Sources Using Environmental Chambers, Version 1.1 (CA Section 0135). For more information visit <https://www.cdph.ca.gov/>
- To access the list of UL Greenguard Gold Certified Products, visit <https://spot.ul.com/main-app/products/catalog/?keywords=oatey>

## AVERAGE HANDLING/SET UP TIMES FOR PVC/PVC SOLVENT CEMENTS

Handling/Set Up Time is the time required to handling the joint. In damp or humid weather, allow 50% additional time.

TEMPERATURE DURING ASSEMBLY	PIPE DIAMETER 1/2" TO 1-1/4"	PIPE DIAMETER 1- 1/2" TO 3"	PIPE DIAMETER 4" TO 5"	PIPE DIAMETER 1/2" TO 1-1/4"	PIPE DIAMETER 6" TO 8"	PIPE DIAMETER 10" TO 16"
60° to 100°F	2 minutes	5 minutes	15 minutes	30 minutes	2 hours	4 hours
40° to 60°F	5 minutes	10 minutes	30 minutes	90 minutes	8 hours	16 hours
20° to 60°F	12 minutes	12 minutes	60 minutes	3 hours	12 hours	24 hours
0° to 20°F	15 minutes	15 minutes	2 hours	6 hours	24 hours	48 hours

## PVC & ABS AVERAGE JOINT CURE TIMES FOR SOLVENT CEMENTS

PIPE DIAMETER		TEMPERATURE DURING ASSEMBLY AND CURE PERIOD			
		60° TO 100°F 16° TO 38°C	40° TO 60°F 4° TO 16°C	20° TO 40°F -7° TO 4°C	0° TO 20°F -18° TO 7°C
1/2" to 1-1/4" 13 to 32mm	Up to 180 psi	15 minutes	20 minutes	30 minutes	60 minutes
	180+ psi	4 hours	8 hours	36 hours	48 hours
1-1/2" to 3" 40 to 80mm	Up to 180 psi	30 minutes	45 minutes	60 minutes	Please contact Oatey technical services for cure time information
	180+ psi	8 hours	16 hours	3 days	
4" to 5" 100 to 125mm	Up to 180 psi	2 hours	4 hours	36 hours	
	180+ psi	12 hours	24 hours	4 days	
6" to 8" 150 to 200mm	Up to 180 psi	8 hours	16 hours	3 days	
	180+ psi	24 hours	48 hours	9 days	
10" to 16" 250 to 400mm	Up to 100 psi	24 hours	48 hours	8 days	
18" or more 460mm or more	Up to 100 psi	36 hours	3 days	12 days	

Joint cure time is the time required before pressure testing the system. In damp or humid weather allow 50% more cure time.

## CPVC AVERAGE JOINT CURE TIMES FOR SOLVENT CEMENTS

PIPE DIAMETER		TEMPERATURE DURING ASSEMBLY AND CURE PERIOD			
		60° TO 100°F 16° TO 38°C	40° TO 60°F 4° TO 16°C	20° TO 40°F -7° TO 4°C	0° TO 20°F -18° TO 7°C
1/2" to 1-1/4" 13 to 32mm	Up to 180 psi	1 hour	2 hours	Please contact Oatey technical services for cure time information	
	180+ psi	6 hours	3 days		
1-1/2" to 3" 40 to 80mm	Up to 180 psi	5 hours	3 days		
	180+ psi	3 days	1 week		
4" to 5" 100 to 125mm	Up to 180 psi	16 hours	1 week		
	180+ psi	1 week	3 weeks		
6" to 8" 150 to 200mm	Up to 180 psi	1 week	2 weeks		
	180+ psi	2 weeks	4 weeks		
10" to 16" 250 to 400mm	Up to 100 psi				
18" or more 460mm or more	Up to 100 psi				

This data is applicable only for new piping installations and not recommended for repair or cut-ins on hot and cold water distribution systems. Please contact Oatey technical service for recommendations.

Do not test PVC and CVPC piping systems with compressed air or gas.

Notes: Cure schedule is the time required before pressure testing the system  
 - This chart can be used as a guideline to determine joint cure  
 - Cure times stated are for conditions with relative humidity of 60% or less  
 - In damp or humid cold weather allow 50% additional cure time

## OATEY CEMENT CHEMICAL COMPATIBILITY CHART

Chemical Name	Conc.	ABS	CPVC	PVC	EP42/CPVC Industrial
Acetic Acid CH <sub>3</sub> COOH	< 25%	No	Yes	Yes	Yes
Acetic Acid CH <sub>3</sub> COOH	> 25%		No	73	No
Alcohol, Methyl, Ethyl, Propyl, Iso-Propyls			No	Yes	No
Alcohol, Potable (Beer, Wine, Spirits)		73	Yes	Yes	Yes
Amines		No	No	No	No
Ammonia Hydroxide NH <sub>4</sub> OH	Sat'd.		No	No	No
Ammonium Hydroxide NH <sub>4</sub> OH	0.1	120	No	No	No
Ammonia Liquid NH <sub>3</sub>	1	Yes	No	No	No
Ammonia Gas NH <sub>3</sub>	1	No	No	Yes	No
Barium Nitrate Ba(NO <sub>3</sub> ) <sub>2</sub>	Sat'd.	73	Yes	73	Yes
Benzene and other Benzene derivatives		No	No	No	No
<i>Benzene Sulfonic Acid C<sub>6</sub>H<sub>5</sub>SO<sub>3</sub>H</i>	0.1		Yes	Yes	Yes
Benzoic Acid C <sub>6</sub> H <sub>5</sub> COOH		Yes	Yes	Yes	Yes
Beverages (Coffee, Milk, Tomato Juice)			Yes	Yes	Yes
Bicarbonate Solutions		73	Yes	Yes	Yes
"Bleach (Sodium Hypochlorite)"	"12% Cl"	73	No	No	Yes
Butane C <sub>4</sub> H <sub>10</sub>	0.5		Yes	Yes	Yes
<i>Calcium Hydroxide Ca(OH)<sub>2</sub></i>		Yes	No	No	Yes
<i>Carbon Dioxide CO<sub>2</sub></i>	All	Yes	Yes	Yes	Yes
Carbon Disulfide CS <sub>2</sub>		No	No	No	No
Carbon Tetrachloride CCl <sub>4</sub>		No	No	73	No
Carbonate Solutions		73	Yes	Yes	Yes
Caustic Soda (Sodium Hydroxide) NaOH	0.4	Yes	No	No	Yes
Chloride Solutions (inorganic)		Yes	Yes	Yes	Yes
Chlorine Gas		No	No	No	No
Chromic Acid H <sub>2</sub> CrO <sub>4</sub>	< 40%	No	Yes	Yes	Yes
Citric Acid C <sub>6</sub> H <sub>8</sub> O <sub>7</sub>	Sat'd.	Yes	Yes	Yes	Yes
Cyclohexanone C <sub>6</sub> H <sub>10</sub> O	Liquid	No	No	No	No
Ethers		No	No	No	No
Ethylene Glycol OHCH <sub>2</sub> CH <sub>2</sub> OH		73	No	Yes	No
Fish Oil			Yes	Yes	Yes
Fluorosilicic Acid (Hydrofluosilicic Acid) H <sub>2</sub> SiF <sub>6</sub>	0.5		73	Yes	73
Freon	1	No	73	Yes	73
Gasohol		No	No	No	No
Gasoline (All)		No	No	No	No
Glycerin C <sub>3</sub> H <sub>5</sub> (OH) <sub>3</sub>		140	Yes	Yes	Yes
Hydrochloric Acid HCl	0.3	No	Yes	Yes	Yes
Hydrogen Peroxide H <sub>2</sub> O <sub>2</sub>	0.9		Yes	Yes	Yes
Hydrogen Sulfide H <sub>2</sub> S	Wet		Yes	Yes	Yes
Hypochlorous Acid HOCl	0.1	73	Yes	Yes	Yes
Kerosene		73	No	No	No
Ketones (all)		No	No	No	No
Methylene Chloride CH <sub>2</sub> Cl <sub>2</sub>			No	No	No

Chemical Name	Conc.	ABS	CPVC	PVC	EP42/CPVC Industrial
Mineral Oil		73	Yes	Yes	Yes
Motor Oil			Yes	Yes	Yes
Nitrate Solutions (Inorganic)		Yes	Yes	Yes	Yes
Nitric Acid HNO3	<10%	No	Yes	Yes	Yes
Nitric Acid HNO3	< 50%	No	No	Yes	No
Nitric Acid HNO3	>50	No	No	No	No
Oleic Acid		Yes	Yes	Yes	Yes
Oxygen O2	Gas	Yes	Yes	Yes	Yes
Phosphate Solutions (Inorganic)		120	Yes	Yes	Yes
Phosphoric Acid H3PO4	<85%		Yes	Yes	Yes
Phthalates		No	No	No	No
Plant Based Oils (Castor, Corn, Linseed, Olive, Vegetable)			No	Yes	No
Plating Solutions (Brass, Chrome, Tin, Zinc,)			Yes	Yes	Yes
Potassium Fluoride KF			Yes	Yes	Yes
Potassium Iodide KI			Yes	73	Yes
Propylene Glycol	All		No	No	No
Salt Solutions	Sat'd.	Yes	Yes	Yes	Yes
Silicone Oil			Yes	73	Yes
Soaps		73	Yes	Yes	Yes
Sodium Chlorate NaClO3	Sat'd.		Yes	73	Yes
Sodium Chlorite NaClO2	0.25		Yes	No	Yes
Sodium Fluoride NaF		120	Yes	Yes	Yes
Sodium Hydroxide NaOH	< 5%		Yes	Yes	Yes
Sodium Hydroxide NaOH	< 70%	120	No	No	Yes
Sodium Hypochlorite NaOCl•5H2O		120	No	No	Yes
Starch, Dextrin, Gelatin Solutions			Yes	Yes	Yes
Steam		No	No	No	No
Stoddard's Solvent			No	No	No
Sugar Solutions (Dextrose, Fructose, Glucose)			Yes	Yes	Yes
Sulfate Solutions		Yes	Yes	Yes	Yes
Sulfuric Acid H2SO4	<30%	120	Yes	Yes	Yes
Sulfuric Acid H2SO4	< 50%	73	Yes	Yes	Yes
Sulfuric Acid H2SO4	<90%	No	Yes	Yes	Yes
Tetrahydrofuran C4H8O		No	No	No	No
Toluene (Toluol) CH3C6H5		No	No	No	No
Trichloroethylene CHCl=CCl2		No	No	No	No
Turpentine		No	No	Yes	No
Urea CO(NH2)2			Yes	Yes	Yes
Water, All but RO		Yes	Yes	Yes	Yes
Xylene (Xylol) C6H4(CH3)2		No	No	No	No

The information provided in this chart is not guaranteed. The piping system should be tested with the circulating materials under typical application conditions to determine suitability.

*If there is a Yes, then there are no limitations on the use of the cement with this chemical.*

*If there is a No, then you cannot use this chemical with this cement.*

*If there is a temperature, then there is a conditional use with this chemical*

*If there is a blank, this chemical has not been tested with this plastic.*



# SOLVENT WELD TRAINING & CERTIFICATION

PROVIDED **FREE** BY OATEY CO.

Oatey will train and test your plumbing installers on the proper way to prep pipe, apply primer and cement, assemble pipe and cure for perfect leak free installations in accordance with **ASME B31.3**.

Email completed form to [InsideSales@oatey.com](mailto:InsideSales@oatey.com) at least 1 month in advance of requested training date.



## ASME B31.3 Installer Qualifier Training Request Form

Form Submission Date	
Requested Training Date	
Requester (Company or Title)	
Contact Name	
Phone Number	
Fax Number	
Email Address	
Oatey/Hercules Distributor	
Distributor's Phone Number	
Location of Training	
Number of Installers Attending	
Are any Attendees Spanish-Speaking? If yes, how many?	
Will A/V Equipment be provided for PowerPoint? If not, props must be provided (see Page 2).	
PVC or CPVC	

## Purpose:

If your next project requires that the plumbing installers are trained and tested in accordance with ASME B31.3, Oatey has the capability to both train and test each installer.

From a mechanical contractor's point of view, B31.3 verifies that each installer has been properly trained in solvent welding and has passed a bonders procedures qualification test. An ASME B31.3 certification provides the assurance that the appropriate products are used in the correct corresponding applications. The solvent welding training portion of B31.3 is an in depth look at what pipe preparations need completed,

primer and cement application, assembly techniques, and areas of concern such as "interference fit", correct applicator size and cure times. The testing portion requires the installer to assemble a test sample consisting of 3" or 4" schedule 80 components. These samples are allowed to fully cure, then are tested at 750 psi for one hour. The sample cannot leak or separate during that time.

Each installer that attends the solvent welding class and successfully passes the pressure test will receive a "Card" verifying their completion of the ASME B31.3 training class.

## Participation Requirements:

- Contractor Training form and Roster
  - Completed form sent to Oatey (InsideSales@oatey.com) at least 1 month in advance of requested training date
- 12 contractors or less per group – for larger groups special arrangements may be made
- A/V Equipment provided for PowerPoint Training – if not available, props for demonstration of presentation are necessary – pipe fittings, cements, primer, beveling or chamfer tools, etc.
- Materials necessary **PER ATTENDEE** for Training & Certification
  - 12" lengths of 3" or 4" schedule 80 pipe precut, squared off and chamfered prior to training.
  - Two of 3" or 4" schedule 80 caps to match the pipe sizes. For each assembly, one cap should have a one-quarter inch hole drilled in the center to act as air relief, and one cap should remain undrilled.
  - Do not mismatch pipe and fittings – either all PVC or all CPVC and either all 3" or all 4".
- Pipe and fittings should be from the same manufacturer
- 1½" dauber for 3" pipe application and mini roller for 4" pipe application
- Beveling or chamfering tools – grinder, cordless router, file, etc.
- Sharpie Pen to note on fitting – Installer Name, Company, and Date
- Oatey does not charge for the training, provided the pipe and fittings are supplied by the wholesaler, contractor or rep.
- Fittings have to be cured for 4 weeks – please allow up to 8 weeks for testing to be completed.
- Notification of Pass/Fail will be sent from InsideSales@oatey.com
  - Passing contractor will receive a certified card
  - Contractors that do not pass have the ability to retake the test until they pass.
- In order to re-submit assemblies, a WebEx session will be scheduled with those members





INDUSTRY LEADER

SEAL TAPE

**THREAD  
SEALANTS**

CONSISTENCY

VALUE

PRO DOPE

EFFICIENT

MEGALOC

GRRIP

REAL TUFF

RESULTS

TRADITION

LEAK FREE

DONE RIGHT

TEAR RESISTANT

INNOVATIVE TECHNOLOGY

UNIQUE FORMULATION

NO DRIP

TRUSTED

BUILDERS

LEAK DETECTOR

PTFE

CLEAN SEAL

**Oatey** COMMERCIAL

EASY APPLICATION

TOUGH MEGABUBBLE

TEMPERATURE RESISTANT

STRETCH RESISTANT

BRUSH-ON BLOCK

HERCULES

LEGACY



# THREAD SEALANTS

**WHEN IT COMES TO THREAD SEALANTS, NOBODY DOES IT BETTER THAN OATEY® AND HERCULES®.**

Having formulated and manufactured thread sealants for more than 70 years, we continuously respond to the changing needs of professional plumbers with new technology, ideas and products. From low-pressure to high-pressure piping demands, from plastics to metals, as well as the market's need for PTFE — we lead the industry with Thread Sealants and Pipe Joint Compounds that solve the toughest challenges.



## MEGATAPE

### SPECIFICATIONS

- Hercules Megatape provides a clean, positive seal on threaded connections. Megatape is an all-purpose thread sealing tape and can be used with plastic, brass, copper, aluminum, stainless steel, galvanized steel or black iron piping. Its high density and 3.5 mil thickness make it the perfect choice for Plumbing Professionals.
- Hercules Megatape can be used on plastic, brass, copper, aluminum, stainless steel, galvanized steel or black iron piping.
- NOT FOR USE WITH LINES CARRYING OXYGEN.

PRODUCT NO.	SIZE	PACKING	WEIGHT
15100	1/2" X 1000"	63	6.0 lbs
15110	3/4" X 1000"	45	5.5 lbs
15120	1" X 1000"	36	5.65 lbs



## TAPE DOPE® HIGH DENSITY PROFESSIONAL GRADE PTFE THREAD SEALANT

### SPECIFICATIONS

- High density, high quality pipe joint tape for sealing threaded pipe, valves, fittings, accessories and controls. Securely seals all threaded piping including steel, galvanized and black iron, brass, copper, aluminum, stainless steel, glass, Monel, synthetic rubber, and all plastics.
- Does not shred; requires fewer wraps than cheaper inferior tapes. Self-lubricating and excellent dielectric properties minimize galvanic action. Will not harden, crack, or crumble. Joints can be disassembled with ease after years of use.
- Chemically inert, it is ideal for lines carrying water, steam, oils and gases as well as acids, corrosive chemicals, refrigerants, fuels and solvents. Will not contaminate material carried in pipes. Protects against any corrosive action of chemicals. Compressible solid that is not affected by weather.
- Can be used for repairs, original equipment, and maintenance of any threading application.

PRODUCT NO.	SIZE	PACKING	WEIGHT
15124	1/2" x 500"	24	1.55 lbs
15127	1/2" x 750"	24	3.0 lbs
15136	3/4" x 500"	12	1.7 lbs



### APPROVALS & LISTINGS

CUL Listed (MH20734)

When used for the intended end use application, this product is considered an "article" as defined in OSHA 29 CFR 1910.1200(c).

### PHYSICAL PROPERTIES

**Appearance:** Gray Tape

**Density:** 0.70 to 1.00 g/c3

**Pressure Rating\*:** 10,000 psi

**Temperature Range:** -450° F to 500° F

**Tensile Strength:** 1245 to 2500 psi

**Thickness:** 0.0035"

**Shelf Life:** Indefinite

**HMIS® ratings:** Health: 0

Flammability: 0

Physical hazard: 0

\*Pressure rating is relative to the torque and quality of the threads and the amount of tape used.



This product is not classified as hazardous in accordance with OSHA 1910. 1200.

### PHYSICAL PROPERTIES

**Appearance:** White Tape

**Density:** 1.0 - 1.3 g/cc

**Pressure Rating\*:** 10,000 PSI

**Temperature Range:** -450° F to 500° F

**Tensile Strength:** 1900 to 3300 psi

**Thickness:** 0.0035 +/- 0.0005"

**Shelf Life:** Indefinite

### APPLICATION / USES

Aluminum	Galvanized Iron	Steel Accessories
Black Iron	Glass	Steel Controls
Brass	Monel	Synthetic Rubber
Copper	All Plastics	Threaded Pipe
Fittings	Stainless Steel	Valves

**HMIS® ratings:** Health: 0

Flammability: 0

Physical hazard: 0



## TFE PIPE JOINT TAPE

### SPECIFICATIONS

- An economical, low density grade of polytetrafluoroethylene (PTFE) pipe joint tape for sealing threaded pipe, valves, fittings, accessories and controls including those made from steel, galvanized and black iron, brass, copper, aluminum, stainless steel, glass, synthetic rubber, and all plastics.
- TFE Pipe Joint Tape is weather resistant, flexible, non-stick, non-flammable, low dielectric constant, chemically inert and usable at low temperatures. Joints made with TFE Pipe Joint Tape will not "freeze," seize, or harden with age.
- Product withstands temperatures from -450° to 500°F and pressures to 10,000 lbs. psi. Meets or exceeds performance requirements for use on oxygen lines under MIL-T-27720A (ASG). Since TFE pipe joint tape is chemically inert, it is resistant to chemicals, heat, corrosion and impact making it suitable for many applications including use on chemical processing equipment, electrical insulation and mechanical applications. The lubricity of polytetrafluoroethylene helps make threaded joints easy to assemble and disassemble, so product is excellent for applications which are subject to frequent dismantling. White color for universal use. In applications where a heavier gauge, easier to apply, higher density product is desirable, Hercules Tape Dope® may be preferable to TFE Pipe Joint Tape.
- TFE Pipe Joint Tape can be used for repairs and maintenance of any threading application in plumbing, mechanical and chemical processing equipment, or as electrical insulation due to its low dielectric properties.
- Use TFE Pipe Joint Tape for sealing threaded pipes, valves, fittings and accessories.

PRODUCT NO.	SIZE	PACKING	WEIGHT
15162	1/2" x 260"	144	3.7 lbs.
15164	1/2" x 520"	144	4.5 lbs.
15169	1/2" x 1296"	36	2.7 lbs.
15176	3/4" x 520"	36	1.6 lbs.
15183	1" x 520"	36	2.0 lbs.



This product is not classified as hazardous in accordance with 29 CFR OSHA 1910.1200.

### PHYSICAL PROPERTIES

- Appearance:** White Tape
- Density:** 0.35 – 0.45 g/C<sup>3</sup>
- Pressure Rating\*:** 10,000 PSI
- Temperature Range:** -450° F to 500° F
- Thickness:** 0.0030 +/- 0.0005"
- Shelf Life:** Indefinite

**HMIS® ratings:** Health: 0  
 Flammability: 0  
 Physical hazard: 0



## PRO DOPE® THREAD SEALANT

### SPECIFICATIONS

- A versatile thread sealant for use on black iron, galvanized steel, copper, brass and aluminum pipe and fittings. Can be used on lines carrying natural gas, air, steam, hydronic heating, ammonia, brine, diluted acids and sprinkler systems. Pro Dope will not drip, is lead free, non-toxic and won't spill. It is non-separating and provides a tight, positive, leak free seal. Pro Dope prevents rust and inhibits corrosion by forming a protective coating on threads. It is non-hardening and joints can be disassembled without damage to pipe fittings or threads.
- Pro Dope is easily applied with a natural bristle brush in temperatures as low as -15°F and performs over a temperature range of 0°F to +350°F. Pressure rated to 250 psi for liquids and 200 psi for air/steam.
- Pro Dope is a grey colored thread sealant which contains no lead.

PRODUCT NO.	SIZE	PACKING	WEIGHT
15420	1/2 pt.* (1 lb.)	24	22.8 lbs.
15427	1 pt.* (2 lb.)	12	22.5 lbs.
15433	6 lb. pail**	6	39.0 lbs.
15435	1 gal. pail	4	59.0 lbs.
15445	5 gal. pail**	1	72.0 lbs.

\*Brush in Cap

\*\*Plastic Pail w/Handle



### APPROVALS & LISTINGS

Listed to NSF/ANSI 61

Listed with IAPMO

FBC system compatible

This product is not classified as hazardous in accordance with 29 CFR OSHA 1910.1200.

### PHYSICAL PROPERTIES

**Appearance:** Gray colored thread sealant

**Pressure Rating:** 250 psi for liquids and 200 psi for air/steam

**Temperature Performance:** 0°F to 350°F

**Brushability:** -15°F

### APPLICATION / USES

**Pro Dope can be used on these materials:**

Aluminum	Brass
Black Iron	Copper
Galvanized Steel	Monel
Stainless Steel	Many others

**Pro Dope can be used on lines carrying:**

Acids-Dilute	Inert Gases
Air (compressed gaseous)	Natural Gas
Ammonia Anhydrous	Nitrogen Gaseous
Ammonia Gaseous	Soap Liquid
Brine	Steam Lines
Carbon Dioxide	Vegetable Oils
Castor Oils	Water (hot & cold)
Caustic Alkalies (dilute)	Many other uses
Helium Gaseous	

**HMIS® ratings:** Health: 0

Flammability: 1

Physical hazard: 0



## REAL-TUFF™ THREAD SEALANT

### SPECIFICATIONS

- Multi-purpose heavy duty, white, PTFE paste thread sealant for use on Aluminum, Black Iron, Brass, Copper, Glass, Monel, Natural Rubber, Plastic (P.E., Reinforced), PVC, ABS, CPVC, Stainless Steel, Synthetic Rubber (Butyl, Neoprene). Contains a unique system of fine grain PTFE particles specifically designed to fill cracks and tiny thread imperfections. Leak free joints can be tested and put into service at once. Real-Tuff holds tight against expansion, contraction and vibration, is non-separating, will not run or drip from joints, contains no lead. Non-hardening lubricating formula permits low torque make-up and easy disassembly without galling or stripping threads.
- Real-Tuff withstands temperatures from -200°F to +550°F, and provides leak-proof hydraulic resistance to 12,000 psi. Withstands gas pressure up to 2,600 psi.
- Real-Tuff is non-flammable and contains no heavy metals or volatile solvents and is applied easily with a natural bristle brush, even at temperatures as low as -25°F.

PRODUCT NO.	SIZE	PACKING	WEIGHT
15605	2 oz. tube	48 (4-1 doz. trays)	7.7 lbs.
15615	1/4 pt.*	24	11.5 lbs.
15620	1/2 pt.*	24	22.5 lbs.
15625	1 pt.*	12	23.0 lbs.
15632	1 qt.*	12	44.0 lbs.
15635	1 gal.	4	58.1 lbs.

\*Brush in Cap



NSF  
Certified to NSF/ANSI 61



### APPROVALS & LISTINGS

Listed to NSF/ANSI 61

This product is not classified as hazardous in accordance with 20 CFR OSHA 1910.1200.

### PHYSICAL PROPERTIES

**Pressure Rating:** Liquids: 12,000 psi

Gases: 2,600 psi

**Temperature Performance:** -200°F to +550°F

**Brushability:** -25°F

### APPLICATION / USES

**Real-Tuff may be used on these materials:**

Aluminum	Monel	ABS
Black Iron	Natural Rubber	CPVC
Brass	Plastic	Stainless Steel
Copper	(P.E., Reinforced)	Synthetic Rubber
Glass	PVC	(Butyl, Neoprene)

**Real Tuff can be used on lines carrying:**

Acids- Concentrated	Caustic Alkalies (dilute)	Ketones
Acids-Dilute	Coal Gas	Liquefied Pet. Gases
Air Compressed (Gaseous)	Coal Tar Naptha	Lubricating Oils
Alcohols	Cutting Oils	Manufactured Gases
Aliphatic Solvents	Diesel Fuel Oil	Mineral Oils
Ammonia	Dry Cleaning Fluids	Natural Gas
Anhydrous	Ethylene Glycol	Nitrogen Gaseous
Ammonia Gaseous	Fatty Acid (liquid)	Petroleum Solvents
Ammonia Liquefied	Freons (all)	Propane
Aromatic Solvents	Gasohol	Propylene Glycol
Benzene	Gasoline	Soap Liquid
Brine	Glycerine	Sugar Liquid
Butane Gas	Heating Oils	Steam
Carbon Dioxide	Helium Gaseous	Toluene
Carbon	Hydraulic Oils	Tri-Chloro-Ethylene
Tetrachloride	Hydrogen	Vegetable Oils
Castor Oils	Inert Gases	Water (cold & hot)
Caustic Alkalies (concentrated)	Jet Fuel	Water Gas
	Kerosene	Xylene

**HMS® ratings:** Health: 0  
Flammability: 1  
Physical hazard: 0



## GRRIP™ PIPE JOINT & GASKET SEALANT

### SPECIFICATIONS

- All-purpose pipe joint and gasket sealing compound for use on metals including Aluminum, Black Iron, Brass, Copper, Stainless Steel, Galvanized Steel and on Plastics including PVC. Grrip sets up quickly and dries to form a very tough, yet flexible seal which will not harden, crack, crumble or shrink. Provides leak-proof resistance to high pressure, temperature, expansion, contraction and extreme vibration. Joints can be disassembled easily, without damage to pipe or equipment. Grrip can be removed from skin or clothing, tools or equipment with isopropyl alcohol or Hercules For Hands™ Hand Cleaners.
- Ideal for sealing jobs in plumbing, heating, piping, air conditioning, refrigeration, automotive and innumerable industrial applications. Grrip is applied easily with the natural bristle brush even at temperatures as low as +20°F and performs over a temperature range of -90°F to +450°F. It provides leak proof hydraulic resistance to 12,000 psi and withstands gas pressure 2,600 psi.
- Grrip is a black colored thread sealant which contains no lead.

PRODUCT NO.	SIZE	PACKING	WEIGHT
15510	1/4 pt.*	24	9.6 lbs.
15515	1/2 pt.*	24	18.7 lbs.
15520	1 pt.*	12	19.3 lbs.
15525	1 qt.	12	37.1 lbs.

\*Brush in Cap



### PHYSICAL PROPERTIES

**Pressure Rating:** Liquids 12,000 psi

Gases 2,600 psi

**Temperature Limitations:** -90°F to +450°F

**Brushability:** 20°F

### SPECIFIC APPLICATIONS

**Grrip may be used on these materials:**

Aluminum	Monel
Black Iron	PVC
Brass	Plastic (P.E. Reinforced)
Copper	Stainless Steel
Galvanized Steel	Many others
Glass	

### SPECIFIC USES

**Grrip™ can be used on lines carrying:**

Acids-Dilute Air	Gasoline	Natural Gas
(compressed gases)	Glycerine	Nitrogen (gaseous)
Brine	Heating Oils	Propane
Butane Gas	Helium (gaseous)	Propylene Glycol
Carbon Dioxide	Hydraulic Oils	Soap (liquid)
Castor Oils	Inert Gases	Steam Lines
Cutting Oils	Jet Fuel Kerosene	Vegetable Oils
Diesel Fuel Oil	L. P. Gases	Water (cold & hot)
Ethylene Glycol	Lubricating Oils	Water Gas
Fatty Acid (liquid)	Mineral Oils	Many other uses
Freons (all)		

**HMIS® ratings:** Health: 2  
Flammability: 2  
Physical hazard: 0



## MEGALOC® THREAD SEALANT

### SPECIFICATIONS

- Multi-purpose thread sealant made with DuPont™ KEVLAR® for use on metals including steel, stainless steel, brass, copper, aluminum, and on plastics including PVC, CPVC and ABS. Leak-free joints can be tested and put into service at once. MEGALOC wipes clean from hands and tools with a dry rag, is odor-free, grit-free, and will not separate or settle. MEGALOC does not harden, crack or become brittle; joints can be disassembled without damage to pipe, fittings, or threads years after the joint was made.
- MEGALOC is applied easily with a natural bristle brush even at temperatures as low as -25°F, and performs over a temperature range of -50°F to +400°F. It provides leak-proof hydraulic resistance to 12,000 psi and withstands gas pressure up to 2,600 psi. MEGALOC is non-toxic, non-hazardous, and non-flammable. It contains no lead, heavy metals, or volatile solvents.

PRODUCT NO.	SIZE	PACKING	WEIGHT
15802	1.1 fl. oz. tube**	24	3.0 lbs.
15804	1/4 pt.*	24	13.0 lbs.
15806	1/2 pt.*	24	20.8 lbs.
15808	1 pt.*	12	21.0 lbs.
15811	1 qt.*	12	39.0 lbs.
15814	1 gal.	4	44.7 lbs.
15816	5 gal.	1	59.3 lbs.
15818	55 gal.	1	627.0 lbs.

\* Brush in Cap

\*\*Plastic Tube

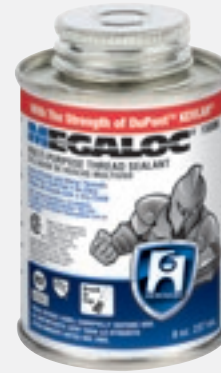

### APPROVALS & LISTINGS

Meets CSA requirements ANSI LC 7-2009 and CAN/ULC-S642-07. This product is not classified as hazardous in accordance with 29 CFR OSHA 1910.1200.

### PHYSICAL PROPERTIES

**Pressure Rating:** Liquids: 12,000 psi

Gases: 2,600 psi

**Temperature Performance:** -50°F to 400°F

**Brushability:** -25°F

### APPLICATION / USES

**MEGALOC can be used on these materials:**

Aluminum	Monel
Black Iron	Fiberglass (reinforced)
Brass	Polyethylene
Copper	Nylon Plastic
Glass	PVC

**MEGALOC can be used on lines carrying:**

Acids (dilute)	Gasoline	Natural Gas
Air (compressed gaseous)	Glycerine	Nitrogen (gaseous)
Brine Butane Gas	Heating Oils	Petroleum Solvents
Carbon Dioxide	Helium (gaseous)	Potable Water
Castor Oils	Hydraulic Oils	Propane
Caustic Alkalis (dilute)	Hydrogen	Propylene Glycol
Cutting Oils	Inert Gases	Soap (liquid)
Diesel Fuel Oil	Jet Fuel	Steam Lines
Ethylene Glycol	Kerosene	Vegetable Oils
Fatty Acid (liquid)	Liquefied Petroleum Gases	Water (cold & hot)
Freons (all)	Lubricating Oils	Many other uses
	Mineral Oils	

**HMIS® ratings:** Health: 0  
Flammability: 1  
Physical hazard: 0

The DuPont™ and KEVLAR® are registered trademarks or trademarks of DuPont or its affiliates.





## BLOCK™ THREAD AND GASKET SEALANT

### SPECIFICATIONS

- All purpose, high performance pipe joint and gasket sealing compound for use on metals including Aluminum, Black Iron, Brass, Copper, Stainless Steel, Galvanized Steel and on Plastics including PVC and CPVC. Block sets up quickly and dries to form a very tough, yet flexible seal which will not harden, crack, crumble or shrink. Provides leak-proof resistance to high pressure, temperature, expansion, contraction and extreme vibration. Joints can be disassembled easily, without damage to pipe or equipment. Block can be removed from skin or clothing, tools or equipment with isopropyl alcohol.
- Ideal for sealing jobs in plumbing, heating, piping, air conditioning, refrigeration, automotive and innumerable industrial applications. Block is applied easily with the natural bristle brush even at temperatures as low as +20°F and performs over a temperature range of -90°F to +450°F. It provides leak proof hydraulic resistance to 12,000 psi and withstands gas pressure to 2,600 psi. Block contains no lead.

PRODUCT NO.	SIZE	PACKING	WEIGHT
15703	1/4 pt.*	24	13.0 lbs.
15707	1/2 pt.*	24	20.8 lbs.
15711	1 pt.*	12	21.0 lbs.
15716	1 qt.*	12	39.0 lbs.

\*Brush in Cap



### PHYSICAL PROPERTIES

**Pressure Rating:** Liquids: 12,000 psi

Gases: 2,600 psi

**Temperature Performance:** -90°F to +450°F

**Brushability:** to 20°F

### APPLICATION / USES

**Block can be used on these materials:**

Aluminum	Glass
Black Iron	Monel
Brass	PVC
Copper	Stainless Steel
Galvanized Steel	Many others

**Block can be used on lines carrying:**

Acids-Dilute	Freons (all)	Natural Gas
Air (compressed gaseous)	Gasoline	Nitrogen (gaseous)
Brine	Glycerine	Propane
Butane Gas	Heating Oils	Propylene Glycol
Carbon Dioxide	Inert Gases	Soap (liquid)
Castor Oils	Jet Fuel	Steam Lines
Cutting Oils	Kerosene	Vegetable Oils
Diesel Fuel Oil	Liquefied	Water (cold & hot)
Ethylene Glycol	Petroleum Gases	Water Gas
Fatty Acid (liquid)	Lubricating Oils	
	Mineral Oils	

**HMS® ratings:** Health: 2  
 Flammability: 2  
 Physical hazard: 0



## THREAD SEALANT APPLICATION CHART

	Megaloc	Pro Dope	Real-Tuff	Tape Dope	TFE Pipe Joint Tape	Block	Grrip
Acids — Concentrated			<input type="checkbox"/>	<input type="checkbox"/>	<input type="checkbox"/>		
Acids — Dilute	<input type="checkbox"/>	<input type="checkbox"/>	<input type="checkbox"/>	<input type="checkbox"/>	<input type="checkbox"/>	<input type="checkbox"/>	<input type="checkbox"/>
Air Compressed (Gaseous)	<input type="checkbox"/>	<input type="checkbox"/>	<input type="checkbox"/>	<input type="checkbox"/>	<input type="checkbox"/>	<input type="checkbox"/>	<input type="checkbox"/>
Alcohols			<input type="checkbox"/>	<input type="checkbox"/>	<input type="checkbox"/>		
Aliphatic Solvents	<input type="checkbox"/>		<input type="checkbox"/>	<input type="checkbox"/>	<input type="checkbox"/>		
Ammonia Anhydrous	<input type="checkbox"/>	<input type="checkbox"/>	<input type="checkbox"/>	<input type="checkbox"/>	<input type="checkbox"/>		
Ammonia Gaseous	<input type="checkbox"/>	<input type="checkbox"/>	<input type="checkbox"/>	<input type="checkbox"/>	<input type="checkbox"/>		
Ammonia Liquefied	<input type="checkbox"/>		<input type="checkbox"/>	<input type="checkbox"/>	<input type="checkbox"/>		
Aromatic Solvents	<input type="checkbox"/>		<input type="checkbox"/>	<input type="checkbox"/>	<input type="checkbox"/>		
Benzene			<input type="checkbox"/>	<input type="checkbox"/>	<input type="checkbox"/>		
Brine	<input type="checkbox"/>	<input type="checkbox"/>	<input type="checkbox"/>	<input type="checkbox"/>	<input type="checkbox"/>	<input type="checkbox"/>	<input type="checkbox"/>
Butane Gas	<input type="checkbox"/>		<input type="checkbox"/>	<input type="checkbox"/>	<input type="checkbox"/>	<input type="checkbox"/>	<input type="checkbox"/>
Carbon Dioxide	<input type="checkbox"/>	<input type="checkbox"/>	<input type="checkbox"/>	<input type="checkbox"/>	<input type="checkbox"/>	<input type="checkbox"/>	<input type="checkbox"/>
Carbon Tetrachloride			<input type="checkbox"/>	<input type="checkbox"/>	<input type="checkbox"/>		
Castor Oils	<input type="checkbox"/>	<input type="checkbox"/>	<input type="checkbox"/>	<input type="checkbox"/>	<input type="checkbox"/>	<input type="checkbox"/>	<input type="checkbox"/>
Caustic Alkalis (Concentrated)			<input type="checkbox"/>	<input type="checkbox"/>	<input type="checkbox"/>		
Caustic Alkalis (Dilute)	<input type="checkbox"/>	<input type="checkbox"/>	<input type="checkbox"/>	<input type="checkbox"/>	<input type="checkbox"/>		
Chlorine Gas				<input type="checkbox"/>	<input type="checkbox"/>		
Coal Gas	<input type="checkbox"/>		<input type="checkbox"/>	<input type="checkbox"/>	<input type="checkbox"/>		
Coal Tar Naptha	<input type="checkbox"/>		<input type="checkbox"/>	<input type="checkbox"/>	<input type="checkbox"/>		
Cutting Oils	<input type="checkbox"/>		<input type="checkbox"/>	<input type="checkbox"/>	<input type="checkbox"/>	<input type="checkbox"/>	<input type="checkbox"/>
Diesel Fuel Oils	<input type="checkbox"/>		<input type="checkbox"/>	<input type="checkbox"/>	<input type="checkbox"/>	<input type="checkbox"/>	<input type="checkbox"/>
Distilled Water				<input type="checkbox"/>	<input type="checkbox"/>		
Dry Cleaning Fluids			<input type="checkbox"/>	<input type="checkbox"/>	<input type="checkbox"/>		
Ethylene Glycol	<input type="checkbox"/>		<input type="checkbox"/>	<input type="checkbox"/>	<input type="checkbox"/>	<input type="checkbox"/>	<input type="checkbox"/>
Fatty Acid (Liquid)	<input type="checkbox"/>		<input type="checkbox"/>	<input type="checkbox"/>	<input type="checkbox"/>	<input type="checkbox"/>	<input type="checkbox"/>
Food Processing Sys. (FDA App.)				<input type="checkbox"/>	<input type="checkbox"/>		
Freons (All)	<input type="checkbox"/>		<input type="checkbox"/>	<input type="checkbox"/>	<input type="checkbox"/>	<input type="checkbox"/>	<input type="checkbox"/>
Gasohol			<input type="checkbox"/>	<input type="checkbox"/>	<input type="checkbox"/>		
Gasoline	<input type="checkbox"/>		<input type="checkbox"/>	<input type="checkbox"/>	<input type="checkbox"/>	<input type="checkbox"/>	<input type="checkbox"/>
Glycerine	<input type="checkbox"/>		<input type="checkbox"/>	<input type="checkbox"/>	<input type="checkbox"/>	<input type="checkbox"/>	<input type="checkbox"/>
Heating Oils	<input type="checkbox"/>		<input type="checkbox"/>	<input type="checkbox"/>	<input type="checkbox"/>	<input type="checkbox"/>	<input type="checkbox"/>
Helium Gaseous	<input type="checkbox"/>	<input type="checkbox"/>	<input type="checkbox"/>	<input type="checkbox"/>	<input type="checkbox"/>	<input type="checkbox"/>	<input type="checkbox"/>
Hydraulic Oils	<input type="checkbox"/>		<input type="checkbox"/>	<input type="checkbox"/>	<input type="checkbox"/>	<input type="checkbox"/>	<input type="checkbox"/>
Hydrogen	<input type="checkbox"/>	<input type="checkbox"/>	<input type="checkbox"/>	<input type="checkbox"/>	<input type="checkbox"/>	<input type="checkbox"/>	<input type="checkbox"/>
Inert Gases	<input type="checkbox"/>	<input type="checkbox"/>	<input type="checkbox"/>	<input type="checkbox"/>	<input type="checkbox"/>	<input type="checkbox"/>	<input type="checkbox"/>

\*Verify suitability with pipe manufacturer

**CONTINUED ON NEXT PAGE.**



## THREAD SEALANT APPLICATION CHART *CONTINUED*

	Megaloc	Pipe Joint Compound	Pro Dope	Real-Tuff	Tape Dope	TFE Pipe Joint Tape	Block	Grip
Jet Fuel	<input type="checkbox"/>			<input type="checkbox"/>	<input type="checkbox"/>	<input type="checkbox"/>	<input type="checkbox"/>	<input type="checkbox"/>
Kerosene	<input type="checkbox"/>			<input type="checkbox"/>	<input type="checkbox"/>	<input type="checkbox"/>	<input type="checkbox"/>	<input type="checkbox"/>
Ketones				<input type="checkbox"/>	<input type="checkbox"/>	<input type="checkbox"/>		
Liquified Pet. Gases	<input type="checkbox"/>			<input type="checkbox"/>	<input type="checkbox"/>	<input type="checkbox"/>	<input type="checkbox"/>	<input type="checkbox"/>
Lubricating Oils	<input type="checkbox"/>			<input type="checkbox"/>	<input type="checkbox"/>	<input type="checkbox"/>	<input type="checkbox"/>	<input type="checkbox"/>
Manufactures Gases				<input type="checkbox"/>	<input type="checkbox"/>	<input type="checkbox"/>		
Mineral Oils	<input type="checkbox"/>			<input type="checkbox"/>	<input type="checkbox"/>	<input type="checkbox"/>	<input type="checkbox"/>	<input type="checkbox"/>
Natural Gas	<input type="checkbox"/>	<input type="checkbox"/>	<input type="checkbox"/>	<input type="checkbox"/>	<input type="checkbox"/>	<input type="checkbox"/>	<input type="checkbox"/>	<input type="checkbox"/>
Nitrogen Gaseous	<input type="checkbox"/>	<input type="checkbox"/>	<input type="checkbox"/>	<input type="checkbox"/>	<input type="checkbox"/>	<input type="checkbox"/>	<input type="checkbox"/>	<input type="checkbox"/>
Oxygen Gaseous					<input type="checkbox"/>			
Petroleum Solvents				<input type="checkbox"/>	<input type="checkbox"/>	<input type="checkbox"/>		
Propane	<input type="checkbox"/>			<input type="checkbox"/>	<input type="checkbox"/>	<input type="checkbox"/>	<input type="checkbox"/>	<input type="checkbox"/>
Propylene Glycol	<input type="checkbox"/>			<input type="checkbox"/>	<input type="checkbox"/>	<input type="checkbox"/>	<input type="checkbox"/>	<input type="checkbox"/>
Soap Liquid	<input type="checkbox"/>	<input type="checkbox"/>	<input type="checkbox"/>	<input type="checkbox"/>	<input type="checkbox"/>	<input type="checkbox"/>	<input type="checkbox"/>	<input type="checkbox"/>
Steam Lines	<input type="checkbox"/>	<input type="checkbox"/>	<input type="checkbox"/>	<input type="checkbox"/>	<input type="checkbox"/>	<input type="checkbox"/>	<input type="checkbox"/>	<input type="checkbox"/>
Sugar Liquid	<input type="checkbox"/>			<input type="checkbox"/>	<input type="checkbox"/>	<input type="checkbox"/>		
Toluene				<input type="checkbox"/>	<input type="checkbox"/>	<input type="checkbox"/>		
Tri-Chloro-Ethylene				<input type="checkbox"/>	<input type="checkbox"/>	<input type="checkbox"/>		
Vegetable Oils	<input type="checkbox"/>	<input type="checkbox"/>	<input type="checkbox"/>	<input type="checkbox"/>	<input type="checkbox"/>	<input type="checkbox"/>	<input type="checkbox"/>	<input type="checkbox"/>
Water (Cold & Hot)	<input type="checkbox"/>	<input type="checkbox"/>	<input type="checkbox"/>	<input type="checkbox"/>	<input type="checkbox"/>	<input type="checkbox"/>	<input type="checkbox"/>	<input type="checkbox"/>
Water Gas	<input type="checkbox"/>			<input type="checkbox"/>	<input type="checkbox"/>	<input type="checkbox"/>	<input type="checkbox"/>	<input type="checkbox"/>
Xylene				<input type="checkbox"/>	<input type="checkbox"/>	<input type="checkbox"/>		
<b>PIPE, VALVE, FITTING:</b>								
ABS	<input type="checkbox"/>			<input type="checkbox"/>	<input type="checkbox"/>	<input type="checkbox"/>		
Aluminum	<input type="checkbox"/>	<input type="checkbox"/>	<input type="checkbox"/>	<input type="checkbox"/>	<input type="checkbox"/>	<input type="checkbox"/>	<input type="checkbox"/>	<input type="checkbox"/>
Black Iron	<input type="checkbox"/>	<input type="checkbox"/>	<input type="checkbox"/>	<input type="checkbox"/>	<input type="checkbox"/>	<input type="checkbox"/>	<input type="checkbox"/>	<input type="checkbox"/>
Brass	<input type="checkbox"/>	<input type="checkbox"/>	<input type="checkbox"/>	<input type="checkbox"/>	<input type="checkbox"/>	<input type="checkbox"/>	<input type="checkbox"/>	<input type="checkbox"/>
C.P.V.C.*	<input type="checkbox"/>			<input type="checkbox"/>	<input type="checkbox"/>	<input type="checkbox"/>	<input type="checkbox"/>	<input type="checkbox"/>
Copper	<input type="checkbox"/>	<input type="checkbox"/>	<input type="checkbox"/>	<input type="checkbox"/>	<input type="checkbox"/>	<input type="checkbox"/>	<input type="checkbox"/>	<input type="checkbox"/>
Glass	<input type="checkbox"/>	<input type="checkbox"/>	<input type="checkbox"/>	<input type="checkbox"/>	<input type="checkbox"/>	<input type="checkbox"/>	<input type="checkbox"/>	<input type="checkbox"/>
Monel	<input type="checkbox"/>	<input type="checkbox"/>	<input type="checkbox"/>	<input type="checkbox"/>	<input type="checkbox"/>	<input type="checkbox"/>	<input type="checkbox"/>	<input type="checkbox"/>
Natural Rubber				<input type="checkbox"/>	<input type="checkbox"/>	<input type="checkbox"/>		
P.V.C.	<input type="checkbox"/>			<input type="checkbox"/>	<input type="checkbox"/>	<input type="checkbox"/>	<input type="checkbox"/>	<input type="checkbox"/>
Plastics (P.E. Reinforced)	<input type="checkbox"/>			<input type="checkbox"/>	<input type="checkbox"/>	<input type="checkbox"/>	<input type="checkbox"/>	<input type="checkbox"/>
Stainless Steel	<input type="checkbox"/>	<input type="checkbox"/>	<input type="checkbox"/>	<input type="checkbox"/>	<input type="checkbox"/>	<input type="checkbox"/>	<input type="checkbox"/>	<input type="checkbox"/>
Synthetic Rubber (Butyl, Neoprene)				<input type="checkbox"/>	<input type="checkbox"/>	<input type="checkbox"/>		

\*Verify suitability with pipe manufacturer



PLUGS

PRESSURE

FEET OF HEAD

MUNI-BALL

AIR-LOC

BIG MOUTH PLUGS

NATURAL RUBBER

RESIDENTIAL

MULTI-RANGE

COST-EFFECTIVE

CHEMICAL-RESISTANT

TESTING

EASY MANEUVERABILITY

EXCELLENCE

I-SERIES

HEAD PRESSURE

COMMERCIAL APPLICATIONS

LEAK LOCATION TESTS

DEFLECTION GAUGE

**Oatey** COMMERCIAL

PNEUMATIC

TEST BALL

NSF

CLEAN-SEAL

TEST WITH THE BEST

VENTILATORS

DWV

MANOMETER

PRESSURE SENSITIVITY



# CHERNE

**MORE THAN 60 YEARS OF PLUMBING AND  
UNDERGROUND INDUSTRY EXPERIENCE.**

Cherne is the recognized world leader in pipe plug and testing equipment manufacturing. In 1998, Cherne demonstrated its commitment to quality and continuous improvement by achieving ISO 9001 registration. Cherne is the only domestic pipe plug manufacturer to achieve this certification. Serving the plumbing and underground industries for over 60 years, Cherne is dedicated to providing customers with unparalleled product quality in addition to the highest level of customer service.

# CHERNE TESTING EQUIPMENT

Properly testing DWV (drain, waste and vent) lines is an essential part of any plumbing project to ensure a proper installation and be confident all plumbing connections are leak free. Testing may require an assortment of products and Cherne testing equipment makes it easy and efficient to test the entire building floor all at once. Below are some of the most common types of equipment used in Commercial jobs.

**Cherne Plumbing Test-Ball® Plugs** can be used in any type of pipe, inserted through a test tee and sealed out of round pipe.

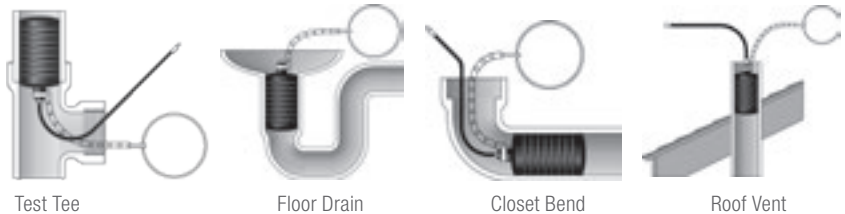

**Cherne Long Test-Ball® Plugs** are designed for waste stack testing or sewer air tests.

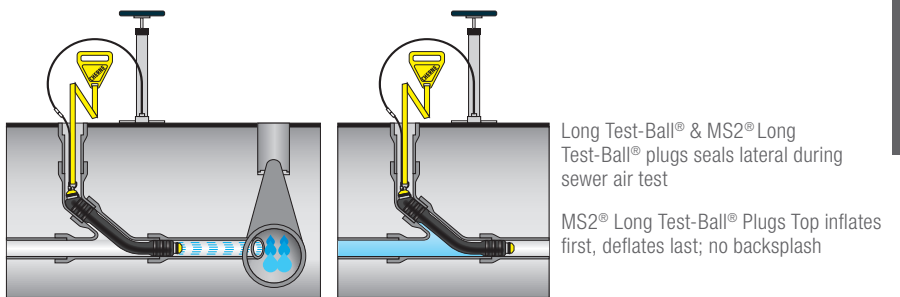

**Cherne Clean-Seal® Plugs** are designed for stack testing of drain, waste and vent plumbing systems and thread into a standard test tee.

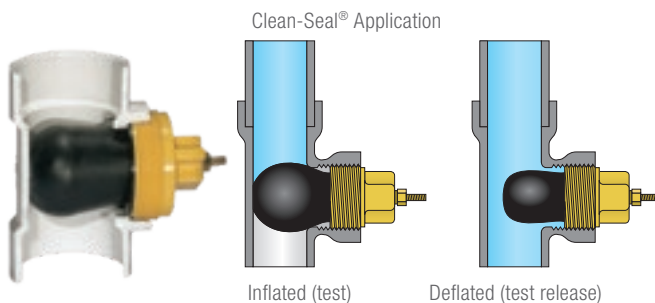

**Cherne Gripper Plugs** can be used in a variety of applications including DWV testing and stack testing.

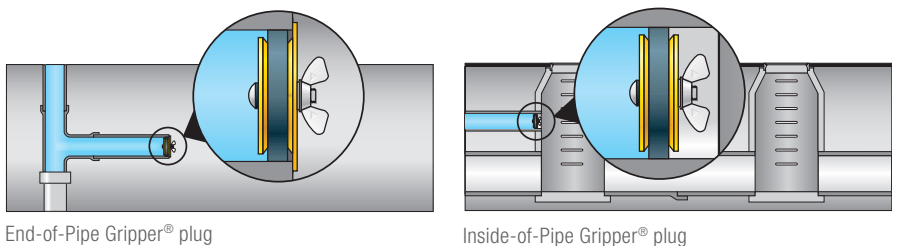

**Cherne Sure-Grip Plugs** have a variety of applications and fit all types of pipe at nominal sizes.

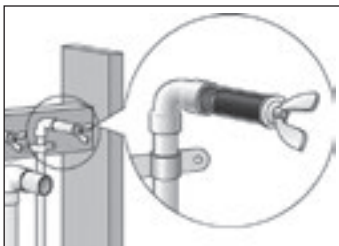

# DWV TESTING TYPES

## WATER TEST:

The DWV plumbing system is plugged leaving the top vent open. Water is then introduced to the system, purging any trapped air that may occur. The test passes if no water column is lost or no pressure drop is noted on a gauge.

## AIR TEST:

The DWV plumbing system is plugged at all openings including traps and vents, leaving one opening as a point to both introduce and monitor the test pressure. Air is introduced, pressurizing the system (normally 5 PSI or less), making sure all are outside the danger zone. (See safety and usage instructions.) The test passes if the measurable loss of pressure is within the time and pressure allowances of the test specifications.

## MANOMETER (OR U-TUBE):

Also known as a final test, the manometer test verifies trap tightness in a new plumbing system. All traps are filled with water and all vents are then plugged. The manometer tube is first filled with water so that it “zeroes” out. Then the lower tube of the manometer is placed through a trap. A second hose is then put through the same trap and a small amount of pressure is applied. A decrease in water column measured on the manometer scale indicates that there is a leak in the system.

## SCENT TEST:

The DWV system is plugged at all openings except one. Liquid scent is applied in that opening, which is then plugged. Leaks are detected via smell.

## CALCULATING HEAD PRESSURE/ FEET OF HEAD

- 1) Measure the distance of the pipe and multiply it by the slope of the grade.
- 2) Measure the distance of the pipe above the plug (used when pipe is vertical).

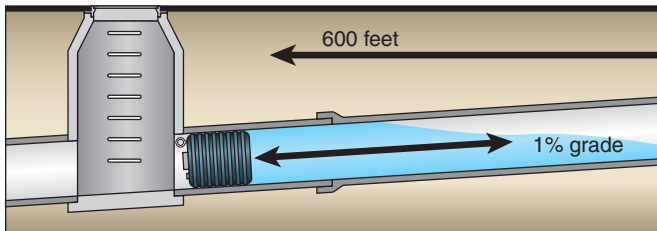

In the example above, the answer is  $600 \times .01 = 6$  feet of head.

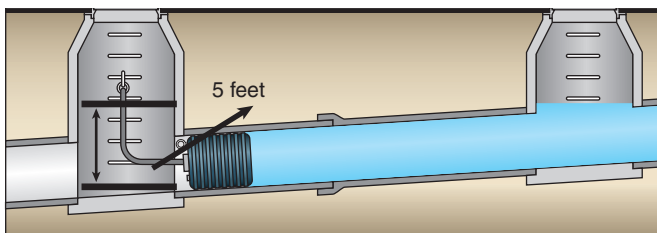

- 3) Attach a hose to a Muni-Ball® bypass. Raise the hose until the flow stops. Measure the height of the water in the hose.

In the example above, the answer is 5 feet of head.

## MEASURES CONVERSION CHART

UNIT	=	CONVERSION FACTOR	X	UNIT
Pounds per square inch	=	14.5	x	Bars
Gallons	=	7.48052	x	Cubic feet
Meters	=	.3048	x	Feet
Inches of mercury	=	.8825	x	Feet of water
Pounds per square inch	=	.4335	x	Feet of water
Millimeters	=	25.4	x	Inches
Feet of water	=	1.133	x	Inches of mercury
Pounds per square inch	=	.4912	x	Inches of mercury
Pounds	=	2.2046	x	Kilograms
Feet	=	3.281	x	Meters
Inches	=	.03937	x	Millimeters
Feet of water	=	2.307	x	Pounds per square inch (PSI)
Inches of mercury	=	2.036	x	Pounds per square inch (PSI)

## PRESSURE CONVERSION CHART

PSI	FEET OF HEAD	PSI	FEET OF HEAD
1	2.31	14	32.33
2	4.62	15	34.64
3	6.93	16	36.94
4	9.24	17	39.25
5	11.55	18	41.56
6	13.85	19	43.87
7	16.16	20	46.18
8	18.47	25	57.73
9	20.78	30	69.27
10	23.09	35	80.82
11	25.40	40	92.36
12	27.71	45	103.91
13	30.02	50	115.45

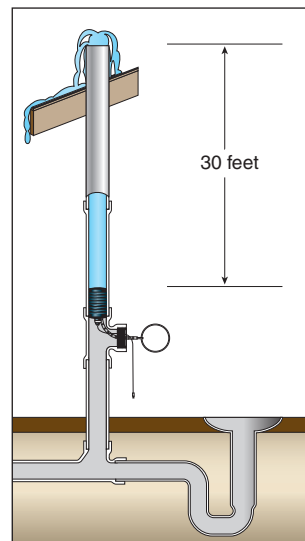

Always block plugs when conducting air tests.

In the example above, the answer is: 30 feet of pipe above the plug = 30 feet of head.



TOTAL SHOWER SOLUTION

**QUICKDRAIN**

PROLINE

WALLDRAIN

ENGINEERED

MICHAEL GRAVES

STYLE

FLEXIBILITY

POSSIBILITIES

FORM

LUXURY

STUNNING

COSMO

HEALTHCARE

SHOWERLINE

RENOVATION

SEAMLESS

COVERAGE

SUSTAINABLE

STACKABLE SPACERS

RENOVATION

CURBLESS

ALL-IN-ONE KIT

UNIVERSAL DESIGN

**Oatey**

**COMMERCIAL**

WALL TO WALL

STAINLESS STEEL

EDGE TO EDGE

TUB TO SHOWER

RETROFIT

ELEMENT

LINEAR DRAIN

DESIGN

TILEIN

ADJUSTABLE

DURABLE

PERFORMANCE

VERSATILITY

FUNCTION



# QUICKDRAIN USA

**MORE THAN A LINEAR DRAIN. A TOTAL SHOWER SOLUTION.**

QuickDrain is a sophisticated curbed or curbless total shower solution that reimagines how a linear drain should perform and be installed. The QuickDrain system can adapt to almost any existing plumbing condition, slashes construction time, saves on cost and minimizes impact on customers.

For more details, visit [www.quickdrainusa.com/quickdrain-submittals](http://www.quickdrainusa.com/quickdrain-submittals)



# WALLDRAIN

## DRAIN BODY KITS

### SPECIFICATIONS

- Length adjustability of drain body with use of drain extensions (24" for each side, 48" total) to accommodate shower sizes from 26" - 72" with the use of one drain and 56" - 96" with two drains linked together.
- Used with topical liquid waterproofing.
- Drain capacity for 2" outlet is 12 GPM (the actual volume is limited by the plumbing lines and P-trap). Multiple drains can be linked together to accommodate greater water flow or larger shower size

PRODUCT NO.	DESCRIPTION	A LENGTH
WALLD48	Vertical Installation Panel, Adjustment Panel, TileIn Cover	48"
WALLD48-SWO	Vertical Installation Panel, Adjustment Panel, TileIn Cover	48"
WALLD72	Vertical Installation Panel, Adjustment Panel, TileIn Cover	72"
WALLD72-SWO	Vertical Installation Panel, Adjustment Panel, TileIn Cover	72"
WALLD96	Vertical Installation Panel, Adjustment Panel, TileIn Cover	2 x 48"
WALLD96-SWO	Vertical Installation Panel, Adjustment Panel, TileIn Cover	2 x 48"
WALLD114	Vertical Installation Panel, Adjustment Panel, TileIn Cover	2 x 72"
WALLD114-SWO	Vertical Installation Panel, Adjustment Panel, TileIn Cover	2 x 72"



Vertical Installation Panel

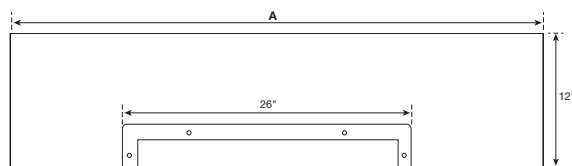

### APPROVALS AND LISTINGS

Before installing QuickDrain USA system, check with your local building department/plumbing inspector to ensure compliance with the local building codes. QuickDrain USA LLC is not responsible for any conflicts with local building codes. QuickDrain USA LLC is not responsible for improper installation of any part of the assembly or the waterproofing membrane. Dimensions are subject to manufacturer's tolerance and can change without notice.

### INCLUDES

- |                                 |                        |
|---------------------------------|------------------------|
| Vertical Installation Panel (1) | 48" Furring Strips (8) |
| (1) WallD24 Drain Body          | Reinforcement Fabric   |
| Adjustment Panel (1)            | Inside Corners (2)     |
| Adjustment Panel Base (1)       | Outside Corners (2)    |
| Magnet Cover (1)                | Transition Tape (1)    |
| Tile Edging (1)                 | Two Band Coupling      |
| Magnets (5)                     |                        |
| TileIn Cover                    |                        |
| Drain Extension (2)             |                        |
| Standoff (2)                    |                        |

Drain Body (side waste, horizontal outlet)

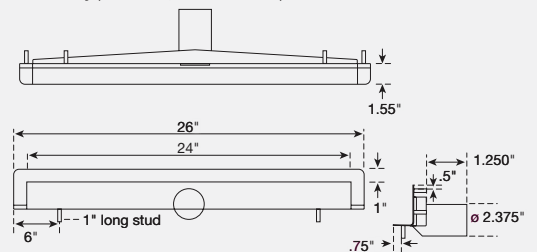

Drain Body (down waste, vertical outlet)

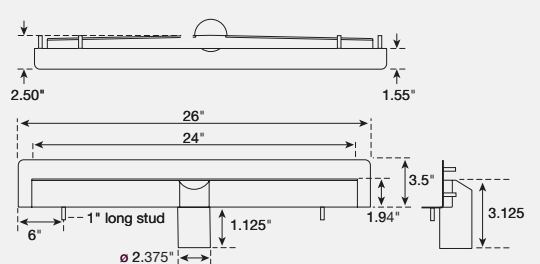

For more details, visit [www.quickdrainusa.com/quickdrain-submittals](http://www.quickdrainusa.com/quickdrain-submittals)



# WALLDRAIN

## WITH COMPLETE QUICKSLOPE PAN KIT

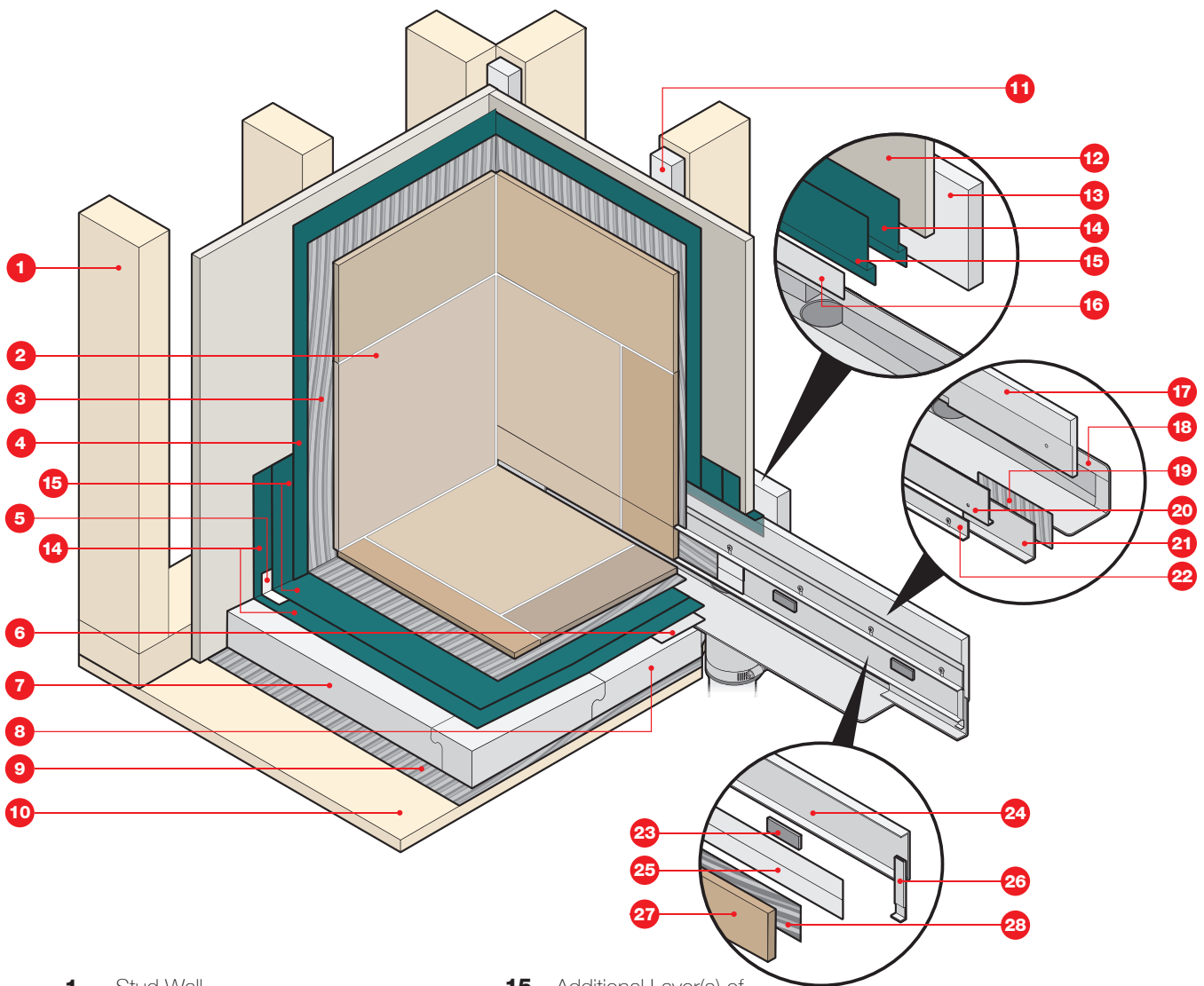

- |           |  |           |   |
|-----------|--|-----------|---|
| <b>1</b>  | Stud Wall                                      | <b>15</b> | Additional Layer(s) of Liquid Waterproofing, as needed per manufacturer's recommendations |
| <b>2</b>  | Wall Tile and Grout                            | <b>16</b> | Transition Tape   |
| <b>3</b>  | Thinset (for wall tile)                        | <b>17</b> | Adjustment Panel  |
| <b>4</b>  | Liquid Wall Waterproofing                      | <b>18</b> | Drain Body  |
| <b>5</b>  | Reinforcing Fabric                             | <b>19</b> | Thinset (for extension)   |
| <b>6</b>  | Transition Tape                                | <b>20</b> | Magnet Cover  |
| <b>7</b>  | Interlocking Slope Panels                      | <b>21</b> | Drain Extension   |
| <b>8</b>  | Horizontal Installation Panel                  | <b>22</b> | Tile Edging   |
| <b>9</b>  | Thinset  | <b>23</b> | Magnet  |
| <b>10</b> | Subfloor                                       | <b>24</b> | Tile-In Cover   |
| <b>11</b> | Furring Strips                                 | <b>25</b> | Transition Tape   |
| <b>12</b> | Wall Board                                     | <b>26</b> | Stand Off   |
| <b>13</b> | Vertical Installation Panel                    | <b>27</b> | Tile  |
| <b>14</b> | First Layer of Shower Pan Liquid Waterproofing | <b>28</b> | Thinset (for Tile-In)   |



# WALLDRAIN

WITH COMPLETE ADA SLOPE KIT

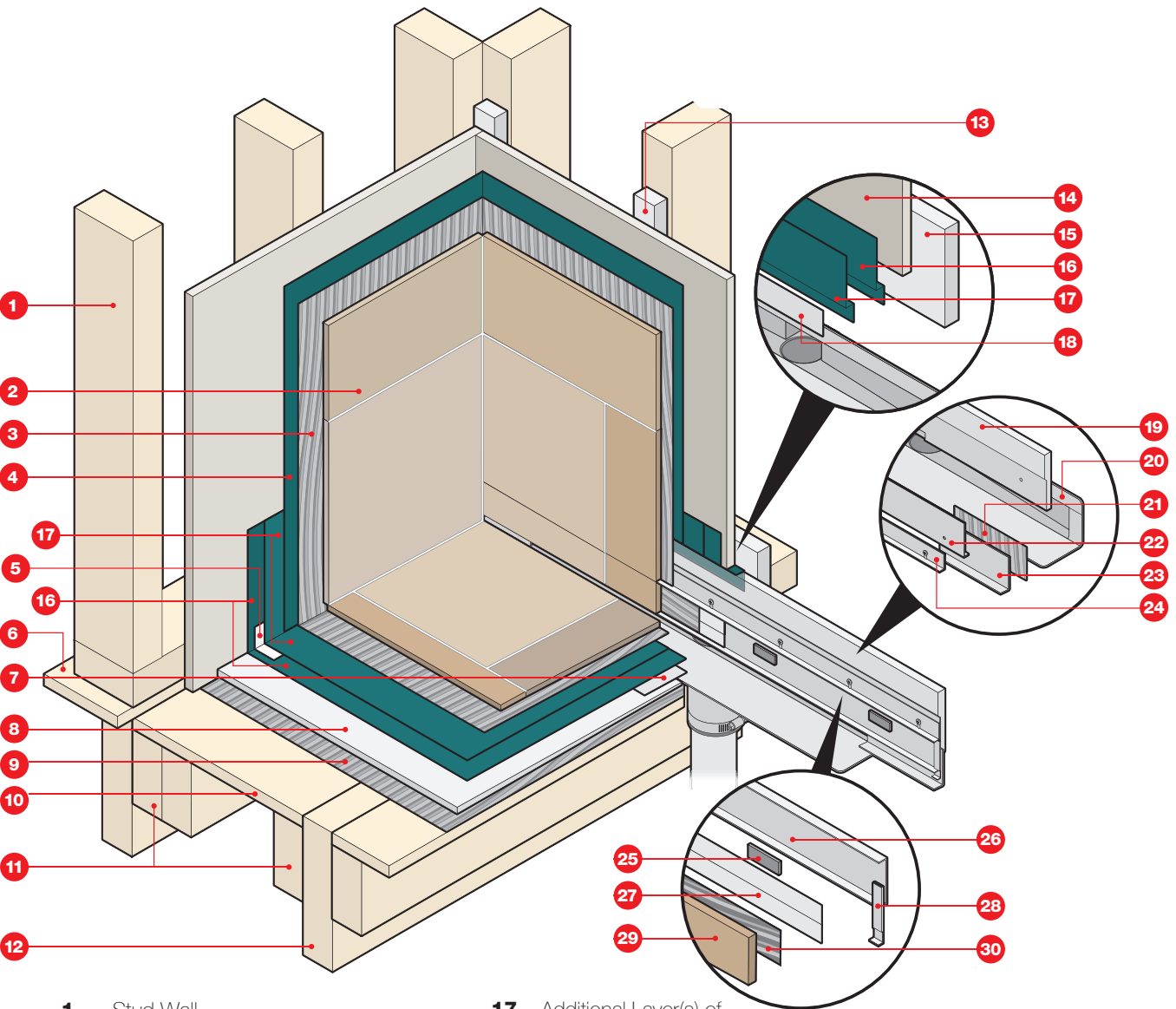

- 1** Stud Wall
- 2** Wall Tile and Grout
- 3** Thinset (for wall tile)
- 4** Liquid Wall Waterproofing
- 5** Reinforcing Fabric
- 6** Transition Tape
- 7** Original Subfloor
- 8** ADA Slope Panel
- 9** Thinset
- 10** Recessed Subfloor
- 11** Blocking Support
- 12** Floor Joists
- 13** Furring Strips
- 14** Wall Board
- 15** Vertical Installation Panel
- 16** First Layer of Shower Pan Liquid Waterproofing

- 17** Additional Layer(s) of Liquid Waterproofing, as needed per manufacturer's recommendations
- 18** Transition Tape
- 19** Adjustment Panel
- 20** Drain Body
- 21** Thinset (for extension)
- 22** Magnet Cover
- 23** Drain Extension
- 24** Tile Edging
- 25** Magnet
- 26** Tile-In Cover
- 27** Transition Tape
- 28** Stand Off
- 29** Tile
- 30** Thinset (for Tile-In)

For more details, visit [www.quickdrainusa.com/quickdrain-submittals](http://www.quickdrainusa.com/quickdrain-submittals)



# WALLDRAIN

## WITH REINFORCED CONCRETE MORTAR BED

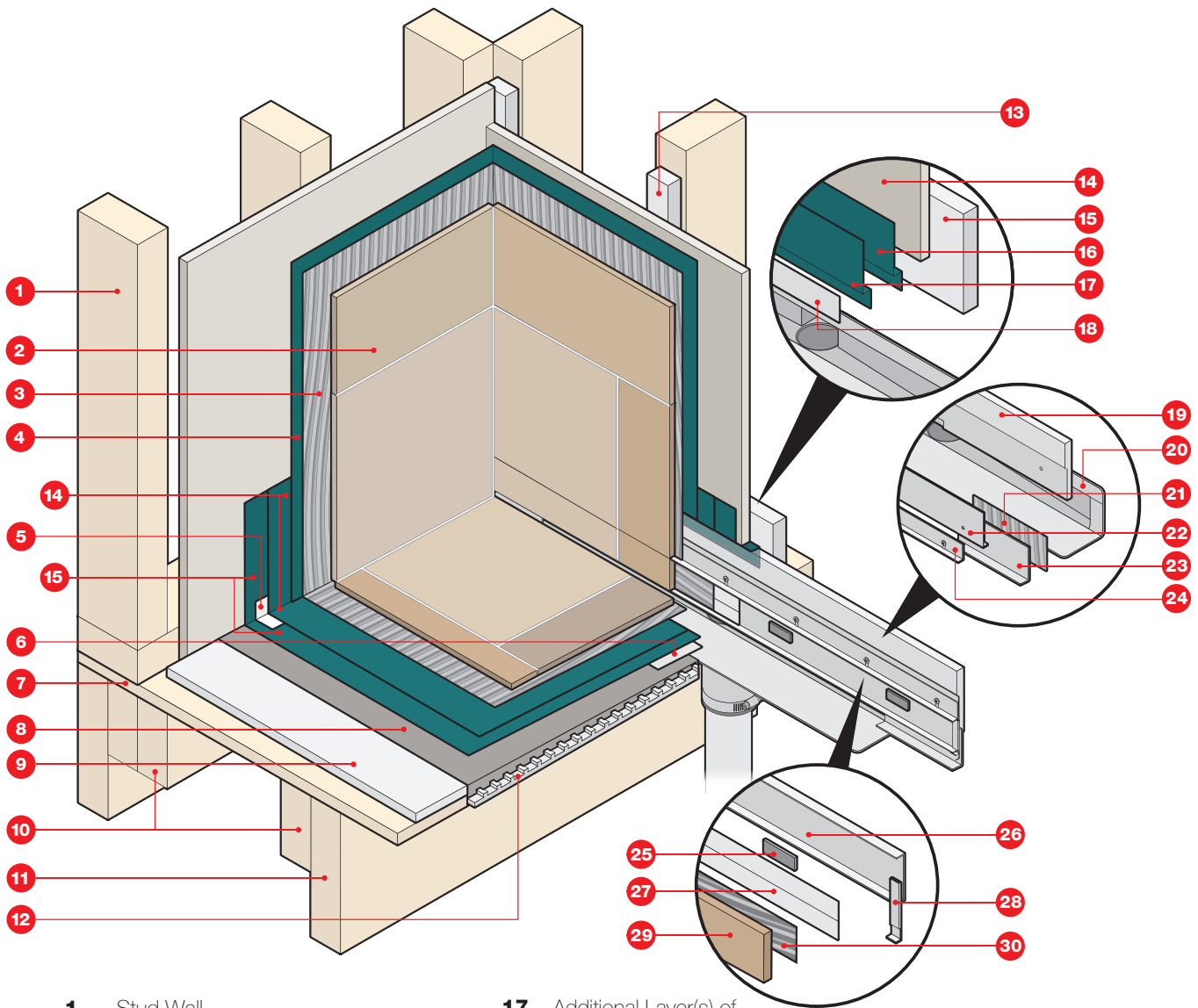

- 1 Stud Wall
- 2 Wall Tile and Grout
- 3 Thinset (for wall tile)
- 4 Liquid Wall Waterproofing
- 5 Reinforcing Fabric
- 6 Transition Tape
- 7 Original Subfloor
- 8 Concrete Slope
- 9 Backer Board
- 10 Blocking Support
- 11 Floor Joists
- 12 Subfloor Substrate
- 13 Furring Strips
- 14 Wall Board
- 15 Vertical Installation Panel
- 16 First Layer of Shower Pan Liquid Waterproofing

- 17 Additional Layer(s) of Liquid Waterproofing, as needed per manufacturer's recommendations
- 18 Transition Tape
- 19 Adjustment Panel
- 20 Drain Body
- 21 Thinset (for extension)
- 22 Magnet Cover
- 23 Drain Extension
- 24 Tile Edging
- 25 Magnet
- 26 Tile-In Cover
- 27 Transition Tape
- 28 Stand Off
- 29 Tile
- 30 Thinset (for Tile-In)



# PROLINE

## CUSTOM FABRICATED DRAIN BODY

### SPECIFICATIONS

- 18 Gauge 316L Stainless Steel.
- Key feature of the drain body is a fully-sloped trough that prevents standing water and solids being deposited into the trough.
- 2" or 1.5" I.D. schedule 10 stainless steel waste outlet.
- Waste outlets may be placed at nearly any location.
- Length adjustability of drain trough with use of trough extensions. QuickDrain USA recommends the drain cover extend the entire length of the shower pan (wall to wall or wall to curb).
- Height adjustability of drain cover with use of spacers for different thicknesses of finished material from 3/8" to 3/4". Custom spacers are available for finished material thicknesses from 1"-2 1/2".
- A signed QuickDrain drawing and purchase order are required to start fabrication on all custom drains.
- A 4-6 week lead time applies to custom orders.
- Custom Product - contact a QuickDrain representative for ordering assistance.

PRODUCT NO.	DESCRIPTION
PLD10 to PLD100 (CMDB)	<b>Non-Standard Size</b> Custom drains made in any size increment between 10"-100" Long. Maximum size with one waste outlet is 68" total length not including the flanges. Drains longer than 68" must have two waste outlets per trough due to the depth, length and internal pitch of the trough.
PLD10 to PLD100 (CMDB)	<b>Commercial Waste Outlet</b> Commercial facilities have special requirements. To meet fireproofing codes, waste outlets can be made in custom lengths from 2" to 14" below the trough. Longer pipes allow waste lines to go through concrete floor so the plumbing connection is done below fireproofing.
PLD10 to PLD100 (CMDB)	<b>Side Waste Outlet</b> Primarily used in retrofitting situations when there are limitations on space and location of existing floors and outlets. The side waste outlet drops and turns 90 degrees and is only 2 9/16" deep, eliminating the need to drill through concrete.
PLD10 to PLD100 (CMDB)	<b>Resinous Drain</b> These drains are suitable for epoxy flooring, urethane and sheet vinyl flooring, making them ideal for commercial use. The trough is surrounded by a 3 1/16" square stainless steel frame. <b>Resinous drain cover required.</b>
PLD10 to PLD100 (CMDB)	<b>Multiple Outlets</b> Water flow output of more than 10 gallons per minute can be addressed with additional outlets on the drain body. QuickDrain waste outlets can accommodate this increased flow. While the appearance is similar to a standard drain, these solutions can double or triple water flow capacity.

### CUSTOM DRAIN DIMENSIONS

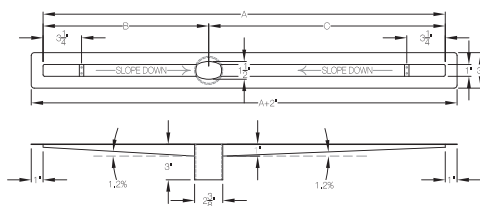

### COMMERCIAL WASTE OUTLET DIMENSIONS

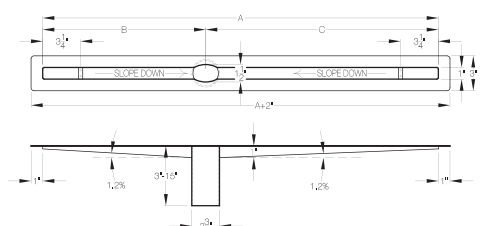

### APPROVALS AND LISTINGS

Before installing QuickDrain USA system, check with your local building department/plumbing inspector to ensure compliance with the local building codes. QuickDrain USA LLC is not responsible for any conflicts with local building codes. QuickDrain USA LLC is not responsible for improper installation of any part of the assembly or the waterproofing membrane. Dimensions are subject to manufacturer's tolerance and can change without notice.

### INCLUDES

- Height Adjustable Spacers
- Trough Extensions (2)
- Approved Two Band Coupling
- Cover Removal Key (2)
- Transition Tape
- Inside Corners (4)
- Outside Corners (2)
- Reinforcement Tape (1)
- \*Quantity varies by drain length

### OPTIONAL ACCESSORIES

- Drain Accessories:** Leveling or Placement Brackets (2)
- Shower Pan Accessories:** Quick Slopes, Flat Panels, Curb Forms
- Liquid Waterproofing Accessories:** Curb Covers

### REQUIRED PART (NOT INCLUDED)

#### Drain Cover

- Available in the designs below and in these lengths – 18", 32", 40", 48", 56", 64", and 72".
- Custom long lengths are an option in the COSMO, HORIZONTAL and VERTICAL designs - 72"-120".
- Resinous drain covers are an option in the COSMO design – 26.5"-100.5".

### RESINOUS DRAIN DIMENSIONS

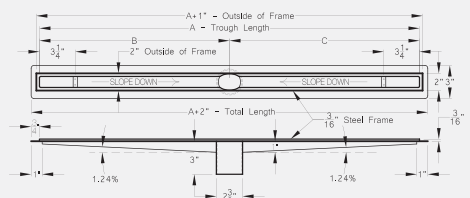

### MULTIPLE OUTLET DIMENSIONS

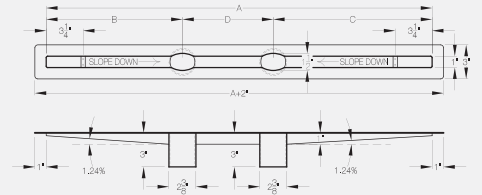

### SIDE WASTE OUTLET DIMENSIONS

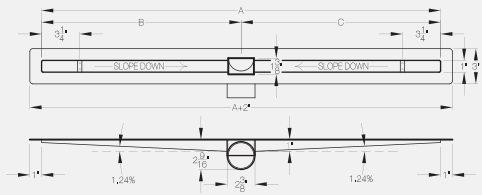

For more details, visit [www.quickdrainusa.com/quickdrain-submittals](http://www.quickdrainusa.com/quickdrain-submittals)



# PROLINE

## CUSTOM FABRICATED COMMERCIAL (LONG) WASTE OUTLET DRAIN BODY

### SPECIFICATIONS

- 18 Gauge 31 6L Stainless Steel.
- Waste outlet can be any length from 2" to 14" below trough.
- Drain body can be any size from 10" to 100".
- Internally pitched channel drain body. No water will be sitting in trough after each use.
- 34" maximum horizontal distance for pitched channel (from edge of trough to center of waste outlet).
- 2" I. D, schedule 10 Steel Pipe waste outlet.
- Waste outlets can be placed at virtually any location.
- Height adjustable cover for thickness of finish from .5" to 2.5".
- Custom Product - contact a QuickDrain representative for ordering assistance.

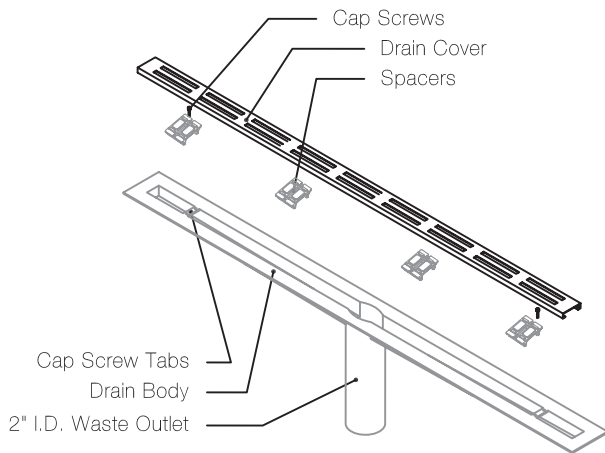

### STRAINER CORNER CONNECTOR

#### SPECIFICATIONS

- Made of 18 gauge 304 stainless steel.
- Connects two strainers at a right angle.
- Comes with two in-line strainer connectors to make connections and one 90° corner strainer extension.
- Works with all strainer types except the tile-in strainer.

PRODUCT NO.	DESCRIPTION
CRCSS	Strainer Corner Connector



### APPROVALS AND LISTINGS

CSA B125.2-2005 / PMG 1 042 Listing / CUPC 6181 Listing

### INCLUDES

- |                           |   |
|---------------------------|---|
| Height Adjustable Spacers | Transition Tape                         |
| Trough Extensions (2)     | Inside Corners (4)                      |
| Approved Two Band         | Outside Corners (2)                     |
| Coupling Cover Removal    | Reinforcement Tape (1)                  |
| Key (2)                   | <i>*Quantity varies by drain length</i> |

### REQUIRED PARTS (NOT INCLUDED)

#### Height Adjustable Spacers

#### Drain Cover

Available in the following lengths: 32", 40", 48", 56", 64" and 72".

### RECOMMENDED PARTS

- Leveling Brackets or Placement Brackets
- Quick Slope
- Outside Corners
- Curb Covers
- Inside Corners

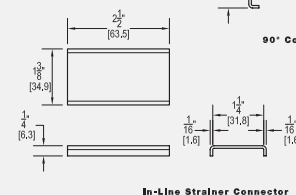
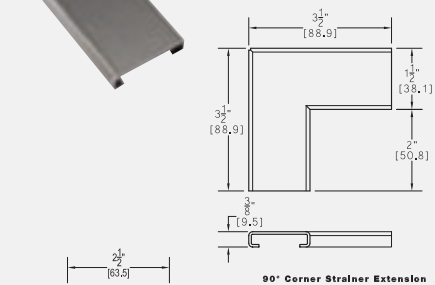
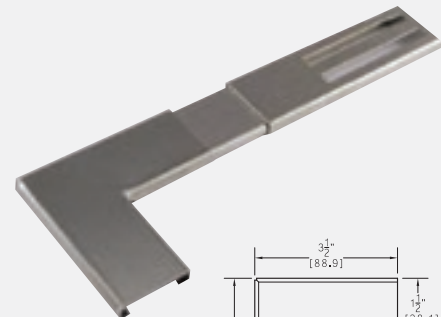
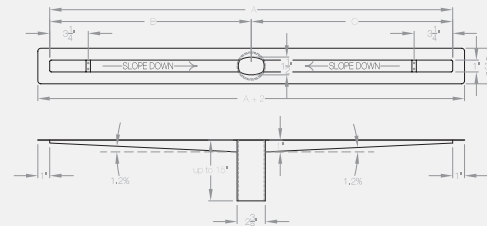

For more details, visit [www.quickdrainusa.com/quickdrain-submittals](http://www.quickdrainusa.com/quickdrain-submittals)





# PROLINE

## 45 DEGREE STRAINER CORNER CONNECTOR

### SPECIFICATIONS

- Made of 18 gauge 304 stainless steel.
- Connects two strainers at a right angle.
- Comes with two in-line strainer connectors to make connections and one 45° corner strainer extension.
- Works with all strainer types except the tile-in strainer.

PRODUCT NO.	DESCRIPTION
N/A	45 Degree Strainer Corner Connector

### CURB FORM

### SPECIFICATIONS

- Prefabricated material made of PET rigid foam (Polyethylene Terephthalate).
- Compression strength of 270 P.8.1.
- Bonds with thinset.
- Necessary part for fast and easy shower pan construction

PRODUCT NO.	DESCRIPTION
SLCURB	Curb Form

### TROUGH EXTENSION

### SPECIFICATIONS

- Protects membrane and funnels all water to drain trough when strainer is oversized.
- Can be trimmed on site to accommodate exact finish opening.
- Works with all strainer types.

PRODUCT NO.	DESCRIPTION
EX4SS	Through Extension

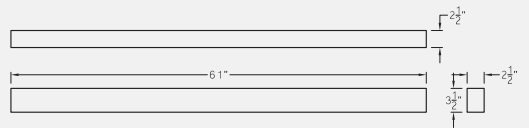
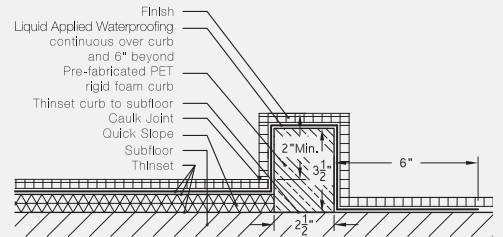
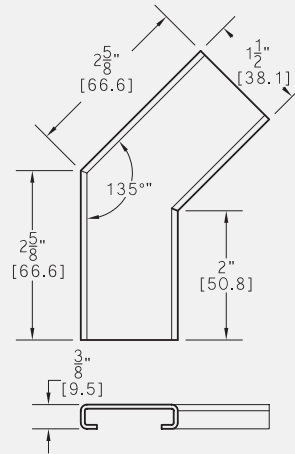
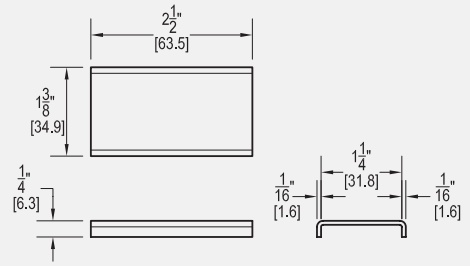

### FEATURES & MATERIALS

**Material:** 26 gauge 304 stainless steel

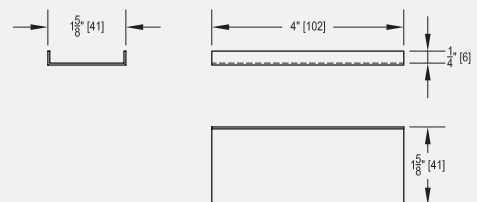

For more details, visit [www.quickdrainusa.com/quickdrain-submittals](http://www.quickdrainusa.com/quickdrain-submittals)



# PROLINE STRAINER CONNECTOR

## SPECIFICATIONS

- Connects multiple strainers in a line.
- Works with all strainer types except the tile in strainer.
- Can be used with or without the strainer extension.
- Can be cut down to accommodate exact finish openings.

PRODUCT NO.	DESCRIPTION
ILCSS	Strainer Connector



## FEATURES & MATERIALS

**Materials:** 18 gauge 304 stainless steel

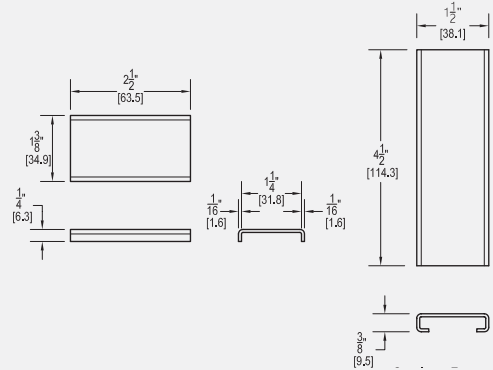

## LONG LEVELING BRACKET

### SPECIFICATIONS

- Placed on either end of drain body with screws to hold drain level - laterally and bilaterally - during installation process.
- Two piece system with wall mounted bracket and drain body bracket.

PRODUCT NO.	DESCRIPTION
LVBSL	Long Leveling Bracket

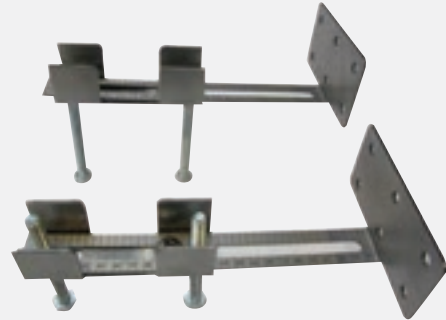

## FEATURES & MATERIALS

**Material:** 16 gauge cold rolled steel

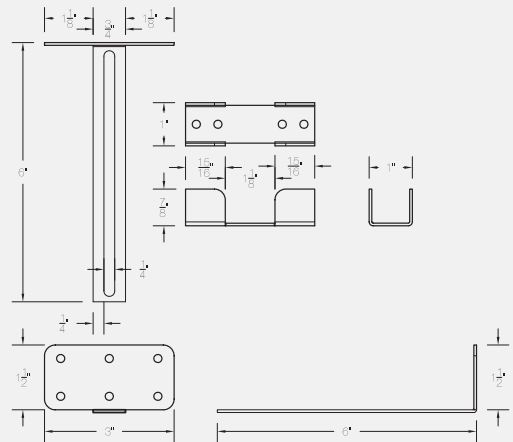

For more details, visit [www.quickdrainusa.com/quickdrain-submittals](http://www.quickdrainusa.com/quickdrain-submittals)



# PROLINE

## SHORT LEVELING BRACKET

### SPECIFICATIONS

- Placed on either end of drain body with screws to hold drain level - laterally and bilaterally - during installation process.
- Two piece system with wall mounted bracket and drain body bracket.

PRODUCT NO.	DESCRIPTION
LVBSS	Short Leveling Bracket

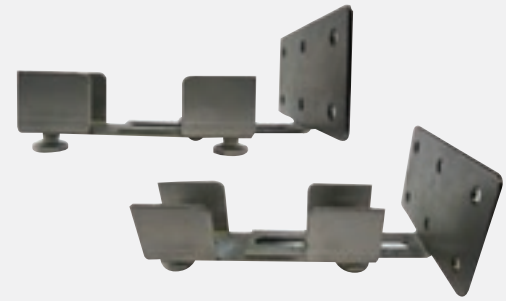

### FEATURES & MATERIALS

**Material:** 16 gauge cold rolled steel

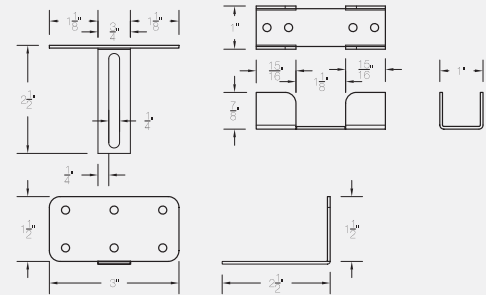

## FLAT PANEL

### SPECIFICATIONS

- ShowerLine pan—Tileable shower receptor for Linear Drain—is made of extruded rigid PET (polyethylene terephthalate) plastic foam. It is strong yet lightweight, non-reactive, economical, and shatterproof.
- Chemically stable, UV resistant and suitable for both interior and exterior use
- Can be used with both sheet and liquid topical waterproofing
- Speed and consistency of installation
- Eliminates the need for traditional mud bed installations
- Lightweight, durable with high compressive strength
- Interlocking design, can be quickly and easily modified to size and shape of on site conditions
- 100% post Consumer recycled and fully recyclable.
- Custom curb sizes available

PRODUCT NO.	DESCRIPTION
SLFP1760	Flat Panel

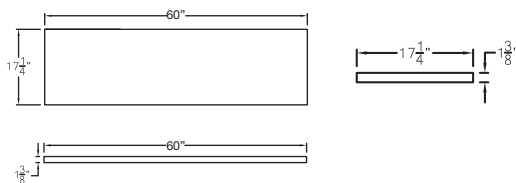

### APPROVALS AND LISTINGS

Before installing QuickDrain USA system, check with your local building department/plumbing inspector to ensure compliance with the local building codes. QuickDrain USA LLC is not responsible for any conflicts with local building codes. QuickDrain USA LLC is not responsible for improper installation of any part of the assembly or the waterproofing membrane. Dimensions are subject to manufacturer's tolerance and can change without notice. IAPMO PS-106-2013

### SHOWERLINE PAN INCLUDES

Flat Panel (SLFP1760)

### SUITABLE SUBSTRATES (INTERIOR ONLY)

Concrete  
Exterior Glue Plywood  
Cement backer board\*\*  
OSB Or Avantech

### APPLICATIONS / USES

Interior and exterior use  
Industrial, commercial and residential showers  
Gang showers  
Pet Showers

### FEATURES & MATERIALS

**Materials:** PET (polyethylene terephthalate) plastic foam

**Compressive Strength:** 145 PSI

For more details, visit [www.quickdrainusa.com/quickdrain-submittals](http://www.quickdrainusa.com/quickdrain-submittals)



# PROLINE PLACEMENT BRACKET

### SPECIFICATIONS

- Can be set on any type of sub-floor.
- Used for setting drain body level with the top of sub-floor.

PRODUCT NO.	DESCRIPTION
PLBSS	Placement Bracket

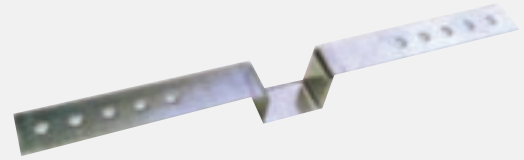

### FEATURES & MATERIALS

**Materials:** 20 gauge galvanized steel

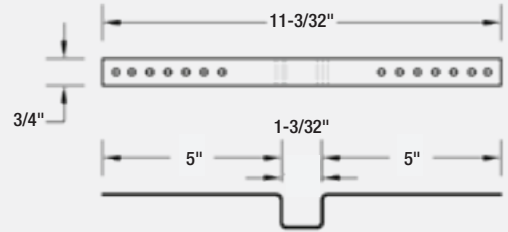

For more details, visit [www.quickdrainusa.com/quickdrain-submittals](http://www.quickdrainusa.com/quickdrain-submittals)



# PROLINE DRAIN BODY

## SPECIFICATIONS

- Key feature of the drain body is a fully sloped trough that prevents standing water and solids being deposited in the trough
- 2" I.D. schedule 10 Steel Pipe waste outlet
- Length adjustability of drain trough with use of trough extensions to accommodate finished openings from 26.25" - 72". QuickDrain USA recommends the drain cover extend the entire length of the shower pan (wall to wall or wall to curb)
- Height adjustability of drain cover with use of spacers for different thicknesses of finish material from 3/8" to 3/4". Custom spacers are available for finish material thicknesses from 1" - 2 1/2"
- Custom drain lengths available from 10"-100". Side outlets, commercial outlets, multiple outlets and resinous drains.
- For more information on our custom drains please visit our website: [www.quickdrainusa.com](http://www.quickdrainusa.com)
- Available with tamper proof cover and screws.

PRODUCT NO.	HEIGHT ADJUSTABLE SPACERS	COVER LENGTH
PLD26-N, PLD27.5-N	4	COVER32
PLD30-N, PLD33-N, PLD36-N	4	COVER40
PLD40-N, PLD44-N, PLD46-N	6	COVER48
PLD48-N, PLD52-N	6	COVER56
PLD57-N	8	COVER64
PLD63-N, PLD68-N	8	COVER72

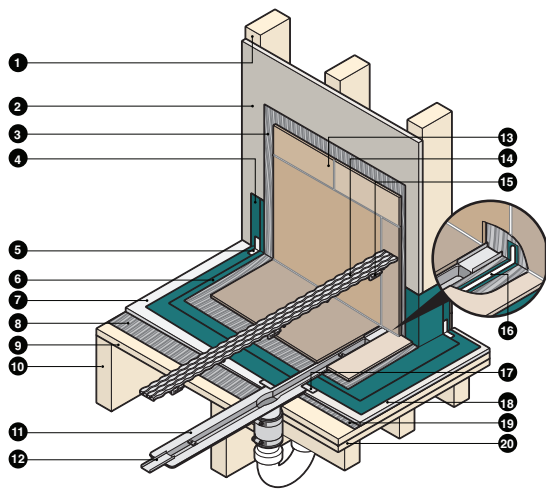

- |  |                                    |
|--|------------------------------------|
| 1 Stud Wall                            | 11 Drain Body                      |
| 2 Wall Board                           | 12 Trough Extension                |
| 3 Thinset (for wall tile)              | 13 Wall Tile and Grout             |
| 4 First layer of Liquid Waterproofing  | 14 Drain Cover                     |
| 5 Reinforcing Fabric                   | 15 Height Adjustable Spacer        |
| 6 Second layer of Liquid Waterproofing | 16 Capillary Break                 |
| 7 Quick Slope                          | 17 Transition Tape                 |
| 8 Thinset                              | 18 De-coupling Crack-isolation Mat |
| 9 Sub-floor                            | 19 Thinset                         |
| 10 Floor Joists (wood floor)           | 20 Blocking (wood floor)           |

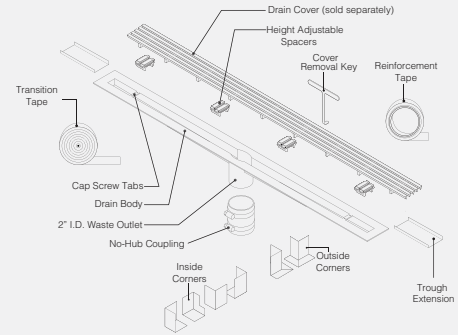

## APPROVALS AND LISTINGS

Before installing QuickDrain USA system, check with your local building department/plumbing inspector to ensure compliance with the local building codes. QuickDrain USA LLC is not responsible for any conflicts with local building codes. QuickDrain USA LLC is not responsible for improper installation of any part of the assembly or the waterproofing membrane. Dimensions are subject to manufacturer's tolerance and can change without notice.

## DRAIN BODY INCLUDES

- |                                |                        |
|--------------------------------|------------------------|
| Height adjustable spacers      | Transition Tape (1)    |
| Trough Extensions (2)          | Inside Corners (4)     |
| Approved Two Band Coupling (1) | Outside Corners (2)    |
| Cover removal key (2)          | Reinforcement Tape (1) |

## REQUIRED PART (NOT INCLUDED)

### Drain Cover

Available in the following lengths: 32", 40", 48", 56", 64" and 72".

### OPTIONAL ACCESSORIES

- Drain Accessories:** Leveling or Placement Brackets (2)
- Shower Pan Accessories:** Quick Slopes, Flat Panels, Curb Forms
- Liquid Waterproofing Accessories:** Curb Covers

## FEATURES & MATERIALS

**Materials:** 18 Gauge 316L Stainless Steel

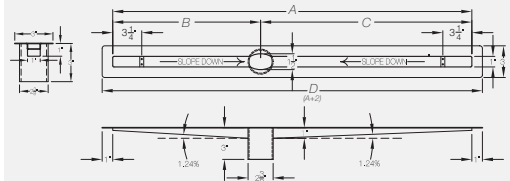

## DIMENSIONS (IN INCHES) SEE ABOVE DIAGRAM

Product No.	A	B	C	D
PLD26-N	26	13	13	28
PLD27.5-N	27.5	13.75	13.75	29.5
PLD30-N	30	12	18	32
PLD33-N	33	16.5	16.5	35
PLD36-N	36	15	21	38
PLD40-N	40	17	23	42
PLD44-N	44	19	25	46
PLD46-N	46	23	23	48
PLD48-N	48	21	27	50
PLD52-N	52	23	29	54
PLD57-N	57	25.5	31.5	59
PLD63-N	63	31.5	31.5	65
PLD68-N	68	34	34	70

For more details, visit [www.quickdrainusa.com/quickdrain-submittals](http://www.quickdrainusa.com/quickdrain-submittals)



# PROLINE DRAIN BODY

## SPECIFICATIONS

- Key feature of the drain body is a fully sloped trough that prevents standing water and solids being deposited in the trough
- 2" I.D. schedule 10 Steel Pipe waste outlet
- Length adjustability of drain trough with use of trough extensions to accommodate finished openings from 26.25" - 72". QuickDrain USA recommends the drain cover extend the entire length of the shower pan (wall to wall or wall to curb)
- Height adjustability of drain cover with use of spacers for different thicknesses of finish material from 3/8" to 3/4". Custom spacers are available for finish material thicknesses from 1" - 2 1/2"
- Custom drain lengths available from 10"-100". Side outlets, end outlets, commercial outlets, multiple outlets and resinous drains.
- For more information on our custom drains please visit our website: [www.quickdrainusa.com](http://www.quickdrainusa.com)

PRODUCT NO.	HEIGHT ADJUSTABLE SPACERS	COVER LENGTH
PLD26-HM, PLD27.5-HM	4	COVER32
PLD30-HM, PLD33-HM, PLD36-HM	4	COVER40
PLD40-HM, PLD44-HM, PLD46-HM	6	COVER48
PLD48-HM, PLD52-HM	6	COVER56
PLD57-HM	8	COVER64
PLD63-HM, PLD68-HM	8	COVER72

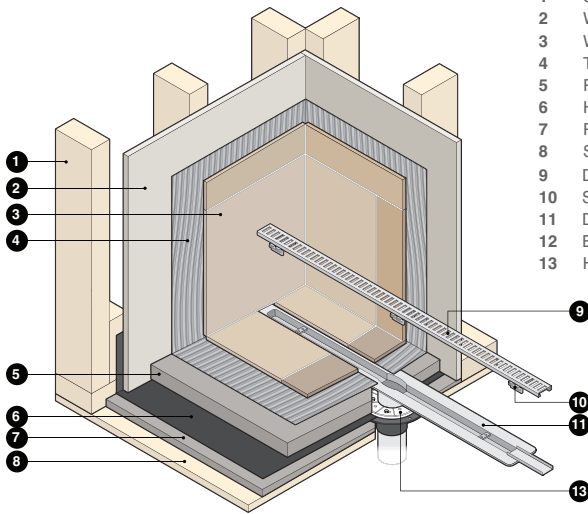

- 1 Stud Wall
- 2 Wall Board
- 3 Wall tile and Grout
- 4 Thinset (for wall tile)
- 5 Reinforced Concrete Slope
- 6 Hot Mop
- 7 Preslope
- 8 Subfloor
- 9 Drain Cover
- 10 Spacer
- 11 Drain Body
- 12 Extension
- 13 Hot Mop Drain-ABS

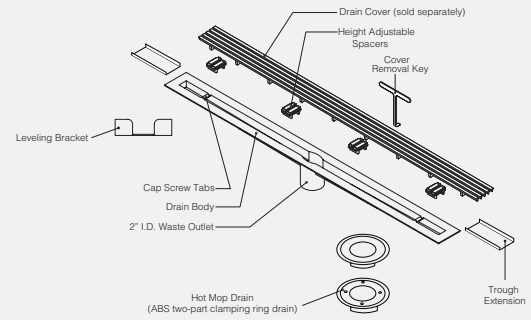

## APPROVALS AND LISTINGS

Before installing QuickDrain USA system, check with your local building department/plumbing inspector to ensure compliance with the local building codes. QuickDrain USA LLC is not responsible for any conflicts with local building codes. QuickDrain USA LLC is not responsible for improper installation of any part of the assembly or the waterproofing membrane. Dimensions are subject to manufacturer's tolerance and can change without notice.

## INCLUDES

- Height adjustable spacers
- Trough Extensions (2)
- Cover Removal Key (2)
- ABS Hot Mop Drain\* (1)
- Leveling Brackets (2)

\*see specifications on page 33

## REQUIRED PART (NOT INCLUDED)

### Drain Cover

Available in the following lengths: 32", 40", 48", 56", 64" and 72".

## FEATURES & MATERIALS

**Materials:** 18 Gauge 316L Stainless Steel

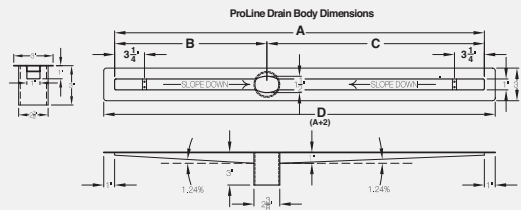

## DIMENSIONS (IN INCHES) SEE ABOVE DIAGRAM

Product No.	A	B	C	D
PLD26-HM	26	13	13	28
PLD27.5-HM	27.5	13.75	13.75	29.5
PLD30-HM	30	12	18	32
PLD33-HM	33	16.5	16.5	35
PLD36-HM	36	15	21	38
PLD40-HM	40	17	23	42
PLD44-HM	44	19	25	46
PLD46-HM	46	23	23	48
PLD48-HM	48	21	27	50
PLD52-HM	52	23	29	54
PLD57-HM	57	25.5	31.5	59
PLD63-HM	63	31.5	31.5	65
PLD68-HM	68	34	34	70

For more details, visit [www.quickdrainusa.com/quickdrain-submittals](http://www.quickdrainusa.com/quickdrain-submittals)



# PROLINE DRAIN BODY

## SPECIFICATIONS

- Key feature of the drain body is a fully sloped trough that prevents standing water and solids being deposited in the trough
- 2" I.D. schedule 10 Steel Pipe waste outlet
- Length adjustability of drain trough with use of trough extensions to accommodate finished openings from 26.25" - 72". QuickDrain USA recommends the drain cover extend the entire length of the shower pan (wall to wall or wall to curb)
- Height adjustability of drain cover with use of spacers for different thicknesses of finish material from 3/8" to 3/4". Custom spacers are available for finish material thicknesses from 1" - 2 1/2"
- Custom drain lengths available from 10"-100". Side outlets, end outlets, commercial outlets, multiple outlets and resinous drains.
- For more information on our custom drains please visit our website: [www.quickdrainusa.com](http://www.quickdrainusa.com)

PRODUCT NO.	HEIGHT ADJUSTABLE SPACERS	COVER LENGTH
PLD26-HMCI, PLD27.5-HMCI	4	COVER32
PLD30-HMCI, PLD33-HMCI, PLD36-HMCI	4	COVER40
PLD40-HMCI, PLD44-HMCI, PLD46-HMCI	6	COVER48
PLD48-HMCI, PLD52-HMCI	6	COVER56
PLD57-HMCI	8	COVER64
PLD63-HMCI, PLD68-HMCI	8	COVER72

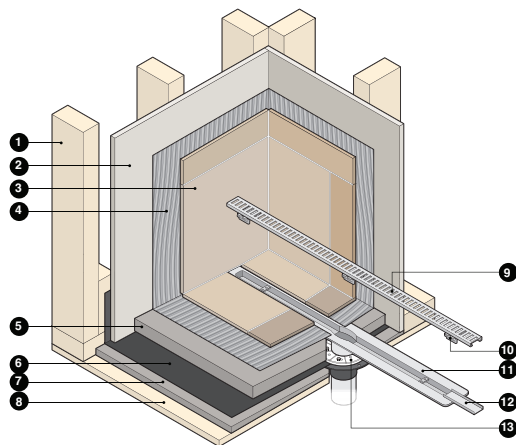

- 1 Stud Wall
- 2 Wall Board
- 3 Wall tile and Grout
- 4 Thinset (for wall tile)
- 5 Reinforced Concrete Slope
- 6 Hot Mop
- 7 Preslope
- 8 Subfloor
- 9 Drain Cover
- 10 Spacer
- 11 Drain Body
- 12 Extension
- 13 Hot Mop Drain-ABS

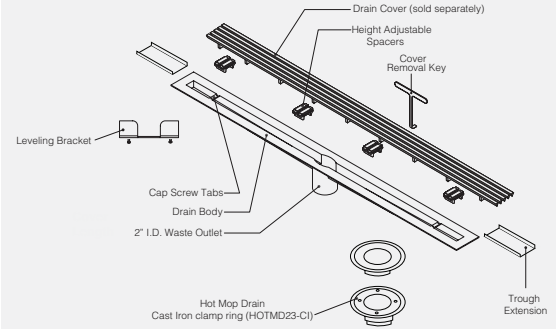

## APPROVALS AND LISTINGS

Before installing QuickDrain USA system, check with your local building department/plumbing inspector to ensure compliance with the local building codes. QuickDrain USA LLC is not responsible for any conflicts with local building codes. QuickDrain USA LLC is not responsible for improper installation of any part of the assembly or the waterproofing membrane. Dimensions are subject to manufacturer's tolerance and can change without notice.

## INCLUDES

- Height adjustable spacers
- Trough Extensions (2)
- Cover Removal Key
- Cast Iron Hot Mop Drain (1)
- Leveling Brackets (2)

## REQUIRED PART (NOT INCLUDED)

### Drain Cover

Available in the following lengths: 32", 40", 48", 56", 64" and 72".

## FEATURES & MATERIALS

**Materials:** 18 Gauge 316L Stainless Steel

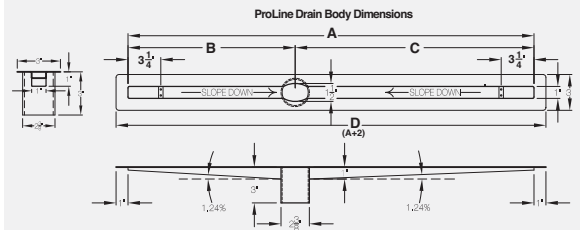

## DIMENSIONS (IN INCHES) SEE ABOVE DIAGRAM

Product No.	A	B	C	D
PLD26-HMCI	26	13	13	28
PLD27.5-HMCI	27.5	13.75	13.75	29.5
PLD30-HMCI	30	12	18	32
PLD33-HMCI	33	16.5	16.5	35
PLD36-HMCI	36	15	21	38
PLD40-HMCI	40	17	23	42
PLD44-HMCI	44	19	25	46
PLD46-HMCI	46	23	23	48
PLD48-HMCI	48	21	27	50
PLD52-HMCI	52	23	29	54
PLD57-HMCI	57	25.5	31.5	59
PLD63-HMCI	63	31.5	31.5	65
PLD68-HMCI	68	34	34	70

For more details, visit [www.quickdrainusa.com/quickdrain-submittals](http://www.quickdrainusa.com/quickdrain-submittals)



# PROLINE

## CUSTOM FABRICATED 2 WASTE OUTLET PROLINE DRAIN BODY

### SPECIFICATIONS

- Doubles drainage capacity.
- Drain body can be any size from 10" to 100".
- Internally pitched channel drain body.
- 34" maximum horizontal distance for pitched channel (from edge of trough to center of waste outlet).
- 2" I.D. schedule 10 Steel Pipe waste outlets.
- Waste outlets can be placed at virtually any location.
- Height adjustable cover for thickness of finish from .5" to 2.5".
- Custom Product - contact a QuickDrain representative for ordering assistance.

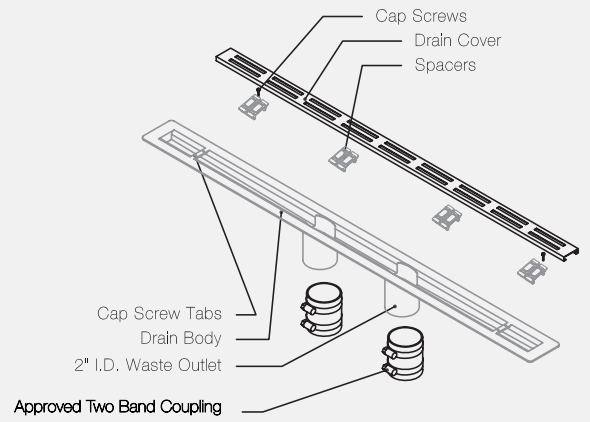

### APPROVALS AND LISTINGS

CSA B125.2-2005  
PMG 1 042 Listing  
CUPC 6181 Listing

### RECOMMENDED PARTS

Leveling Brackets or Placement Brackets  
PET QuickSlope Panels  
Outside Corners  
Curb Covers  
Inside Corners

### REQUIRED PARTS (NOT INCLUDED)

**Height Adjustable Spacers**  
**Drain Cover**

Available in the following lengths: 32", 40", 48", 56", 64" and 72".

### FEATURES & MATERIALS

**Materials:** 18 Gauge 316L Stainless Steel

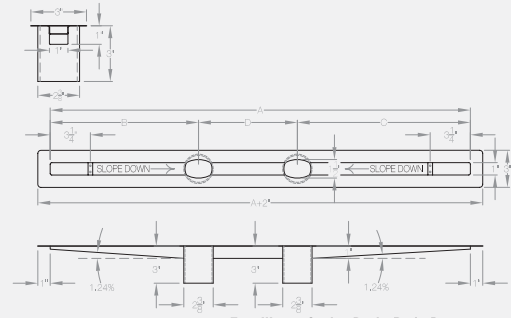

For more details, visit [www.quickdrainusa.com/quickdrain-submittals](http://www.quickdrainusa.com/quickdrain-submittals)





# PROLINE

## CUSTOM FABRICATED 3 WASTE OUTLET PROLINE DRAIN BODY

### SPECIFICATIONS

- Triples drainage capacity.
- Drain body can be any size from 10" to 100".
- Internally pitched channel drain body.
- 34" maximum horizontal distance for pitched channel (from edge of trough to center of waste outlet)
- 2" I.D. schedule 10 Steel Pipe waste outlets.
- Waste outlets can be placed at virtually any location.
- Height adjustable cover for thickness of finish from .5" to 2.5".
- Custom Product - contact a QuickDrain representative for ordering assistance.

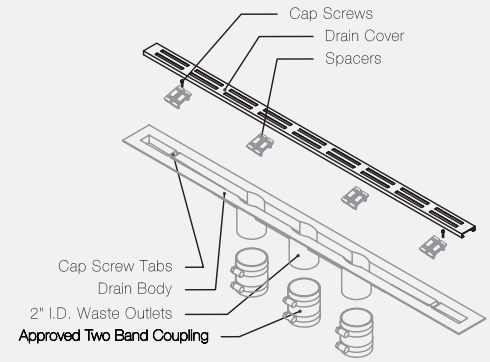

### APPROVALS AND LISTINGS

CSA B125.2-2005  
PMG 1 042 Listing  
CUPC 6181 Listing

### RECOMMENDED PARTS

Leveling Brackets or Placement Brackets  
PET QuickSlope Panels  
Outside Corners  
Curb Covers  
Inside Corners

### REQUIRED PARTS (NOT INCLUDED)

#### Height Adjustable Spacers

#### Drain Cover

Available in the following lengths: 32", 40", 48", 56", 64" and 72".

### FEATURES & MATERIALS

**Materials:** 18 Gauge 316L Stainless Steel

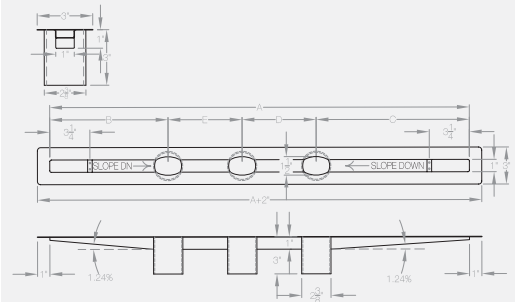



# PROLINE

## CUSTOM FABRICATED COMMERCIAL (LONG) WASTE OUTLET PROLINE DRAIN BODY

### SPECIFICATIONS

- Waste outlet can be fabricated custom length from 2" to 14" below trough.
- Drain body can be any size from 10" to 100".
- Integral waterproofing is factory attached 6" around the entire perimeter of the trough.
- Internally pitched drain body means no water will be sitting in trough after each use.
- 34" maximum horizontal distance for pitched channel.(from edge of trough to center of waste outlet)
- 2" I. D, schedule 10 steel vertical waste outlet.
- Waste outlets can be vertical, horizontal, and end orientation.
- Height adjustable strainer for thickness of finish from .5" to 2.5".
- Custom Product - contact a QuickDrain representative for ordering assistance.

#### Standard Cover Dimensions

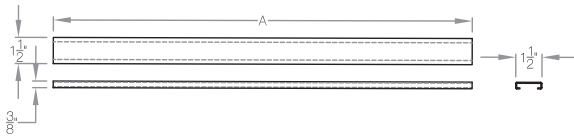

#### Tile-In Cover Dimensions

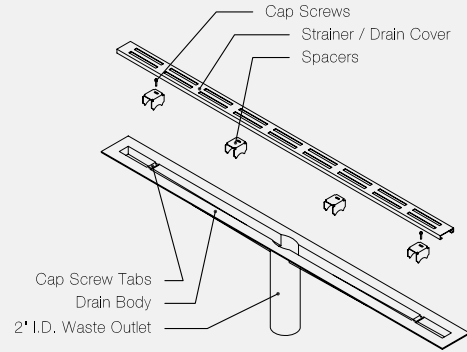
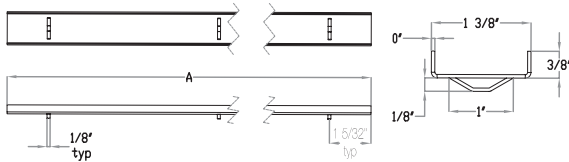

### APPROVALS AND LISTINGS

- 2006 IPC
- 2009 IPC
- 2007 IAPMO/UPC
- IGC 195-2009
- ASME A112.18.2-2005
- CSA B1 25.2-2005
- PMG 1042 Listing
- CUPC 6181 Listing

### RECOMMENDED PARTS

- Leveling Brackets or Placement Brackets
- Quick Slope
- Flat Panel
- Waterproofing Membrane
- Sealant
- Outside Corners

### REQUIRED PARTS (NOT INCLUDED)

- Height Adjustable Spacers
- Drain Cover

Available in the following lengths: 32", 40", 48", 56", 64" and 72".

### FEATURES & MATERIALS

**Materials:** 18 Gauge 316L Stainless Steel

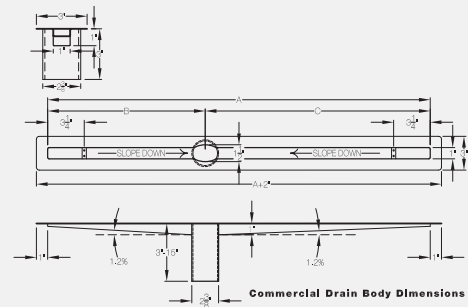

**DIMENSIONS (A, B, C, D):** to customer specification



# PROLINE

## CUSTOM FABRICATED RESINOUS FLOORING PROLINE DRAIN BODY

### SPECIFICATIONS

- Suitable for epoxy, urethane and sheet vinyl flooring.
- Total height from waterproofing to the finished floor, same as top of frame and strainer is 3/16".
- Spot welded resinous lip can be fabricated a minimum of 3/16" and maximum of 1/2" in height to accommodate varying floor thicknesses.
- Drain body can be any size from 10" to 100".
- Internally pitched channel drain body. No water will be sitting in trough after each use.
- 34" maximum horizontal distance for pitched channel. (from edge of trough to center of waste outlet)
- Channel can be flat for longer runs or multiple waste outlets.
- 2" I.D. schedule 10 steel vertical waste outlet.
- Waste outlets can be placed at virtually any location.
- Custom Product - contact a QuickDrain representative for ordering assistance.

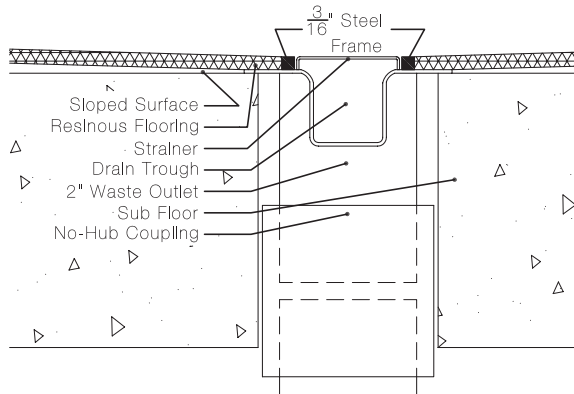

**ProLine Resinous Drain Installation Detail**

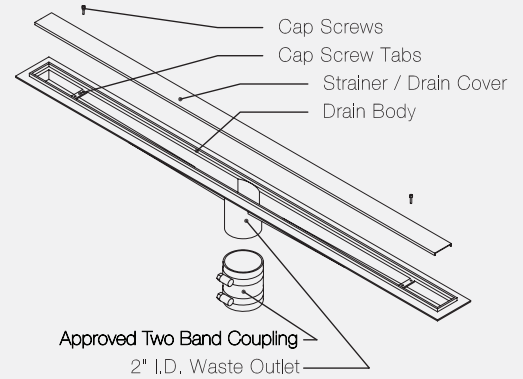

### APPROVALS AND LISTINGS

2006 IPC  
2009 IPC  
2007 IAPMO/UPC  
ASME A112.18.2-2005  
CSA B1 25.2-2005  
ASME A112.6

### RECOMMENDED PARTS

Leveling Brackets or Placement Brackets  
PET QuickSlope Panels  
Flat Panel  
Waterproofing Membrane  
Outside Corners

### REQUIRED PARTS (NOT INCLUDED)

#### Drain Cover

Available in the following lengths: 32", 40", 48", 56", 64" and 72".

### FEATURES & MATERIALS

**Materials:** 18 Gauge 316L Stainless Steel

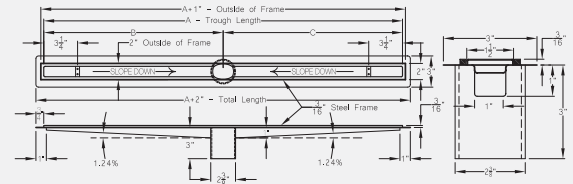

QUICKDRAIN



# PROLINE

## CUSTOM FABRICATED SIDE WASTE OUTLET PROLINE DRAIN BODY

### SPECIFICATIONS

- Used for above-floor waste plumbing installation.
- Drain body custom length from 10" to 100".
- Internally pitched channel drain body. No water will be sitting in trough after each use.
- 34" maximum horizontal distance for pitched channel. (from edge of trough to center of waste outlet)
- 2" I.D. schedule 10 Steel Pipe waste outlet.
- Waste outlets can be placed at virtually any location.
- Height adjustable cover for thickness of finish from .5" to 2.5".
- Custom Product - contact a QuickDrain representative for ordering assistance.



### APPROVALS AND LISTINGS

CSA B125.2-2005  
PMG 1042 Listing  
CUPC 6181 Listing

### RECOMMENDED PARTS

Leveling Brackets or Placement Brackets  
PET QuickSlope Panels  
Sealant  
Outside Corners  
Inside Corners

### REQUIRED PARTS (NOT INCLUDED)

#### Height Adjustable Spacers

#### Drain Cover

Available in the following lengths: 32", 40", 48", 56", 64" and 72".

### FEATURES & MATERIALS

**Materials:** 18 Gauge 316L Stainless Steel

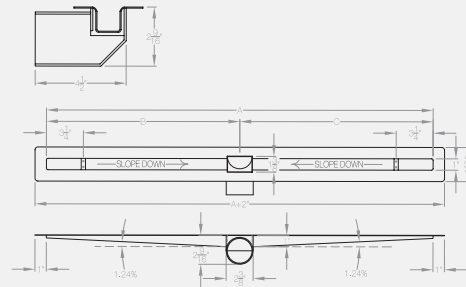

For more details, visit [www.quickdrainusa.com/quickdrain-submittals](http://www.quickdrainusa.com/quickdrain-submittals)



# PROLINE PAN KITS

## SPECIFICATIONS

ProLine pan—Tileable shower receptor for Linear Drain—is made of extruded rigid PET (polyethylene terephthalate) plastic foam. It is strong yet lightweight, non-reactive, economical, and shatterproof.

- Chemically stable, UV resistant and suitable for both in interior and exterior use
- Can be used with both sheet and liquid topical waterproofing
- Speed and consistency of installation
- Eliminates the need for traditional mud bed installations
- Lightweight, durable with high compressive strength
- Interlocking design, can be quickly and easily modified to length and width of on site conditions
- 100% post Consumer recycled and fully recyclable.
- Custom curb sizes available
- PET Pan Kits can be customized upon request

KIT PRODUCT NO.	PRODUCTS & QUANTITY INCLUDED IN KIT			
	DRAIN SUPPORT FRAME	SLQS1652	SLFP1760	SLFP860
PLPAN26	PLDSF26	2	2	-
PLPAN27.5	PLDSF27.5	2	2	-
PLPAN30	PLDSF30	2	2	1
PLPAN33	PLDSF33	2	2	1
PLPAN36	PLDSF36	2	2	1
PLPAN40	PLDSF40	3	3	-
PLPAN44	PLDSF44	3	3	-
PLPAN46	PLDSF46	3	3	1
PLPAN48	PLDSF48	3	3	1
PLPAN52	PLDSF52	3	3	1
PLPAN57	PLDSF57	4	4	-
PLPAN63	PLDSF63	4	4	1
PLPAN68	PLDSF68	4	4	1

## DIMENSIONS (CURB) SLCURB

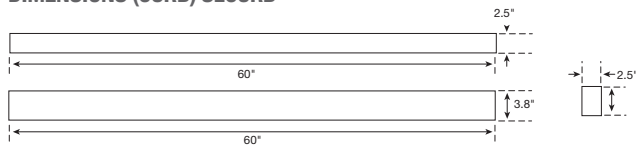

## DIMENSIONS (FLAT PANEL) SLFP1760

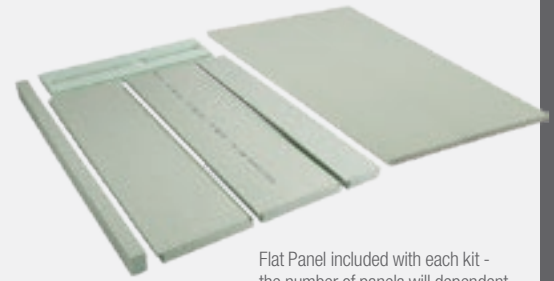
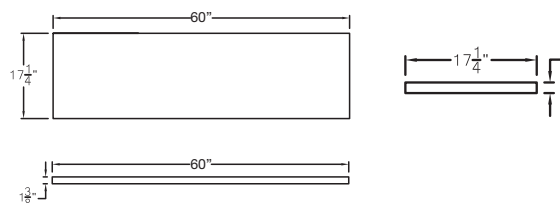

Flat Panel included with each kit - the number of panels will dependent on size of overall showerpan.

## APPROVALS AND LISTINGS

IAPMO PS-106-2013

## INCLUDES

- Flat Panel (SLFP1760)
- Drain Support Frame
- Quick Slope (SLQS1652, SLQS852)\*
- Curb (SLCURB)
- Screws (5)

## SUITABLE SUBSTRATES (INTERIOR ONLY)

- Concrete
- Exterior Glue Plywood
- Cement backer board
- OSB Or Avantech

## FEATURES & MATERIALS

**Materials:** PET (polyethylene terephthalate) plastic foam  
**Compressive Strength:** 145 PSI

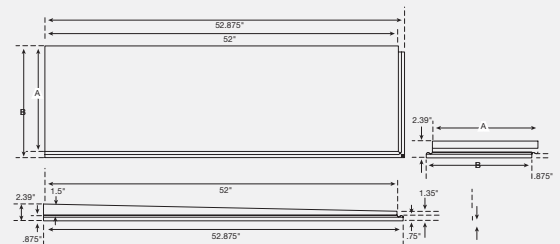

## DIMENSIONS (QUICK SLOPE) SEE ABOVE DIAGRAM

Product No.	A	B
SLQS1652	16"	16.875"
SLQS852	8"	-

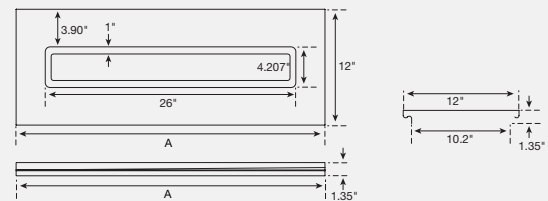

## DIMENSIONS (DRAIN SUPPORT FRAME) SEE ABOVE DIAGRAM

Product No.	A	Product No.	A
PLDSF32	32"	PLDSF52	56"
PLDSF40	40"	PLDSF63	64"
PLDSF48	48"	PLDSF68	72"

For more details, visit [www.quickdrainusa.com/quickdrain-submittals](http://www.quickdrainusa.com/quickdrain-submittals)



# PROLINE SPACER BASE & EXTENDERS (UP TO 7/8" HIGH)

## SPECIFICATIONS

- Spacers are used to set the Cover at the correct elevation after finish tile or stone is installed. This is the same distance as from the waterproofing to top of the finished flooring material
- Total height of spacer and cover from top of drain flange is 7/8"
- Spacers are required

PRODUCT NO.	DESCRIPTION
SP	Spacer Base & Extenders

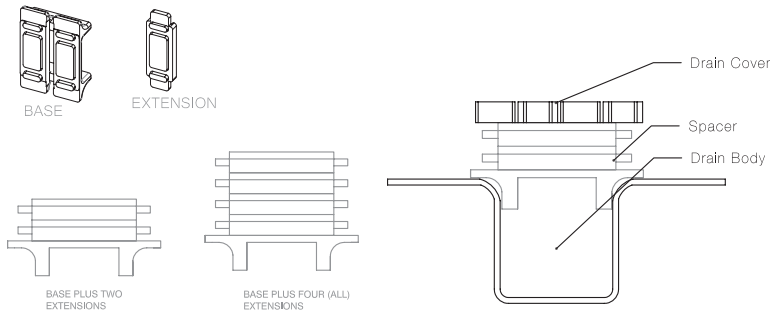

## APPROVALS AND LISTINGS

Before installing QuickDrain USA system, check with your local building department/plumbing inspector to ensure compliance with the local building codes. QuickDrain USA LLC is not responsible for any conflicts with local building codes. QuickDrain USA LLC is not responsible for improper installation of any part of the assembly or the waterproofing membrane. Dimensions are subject to manufacturer's tolerance and can change without notice.

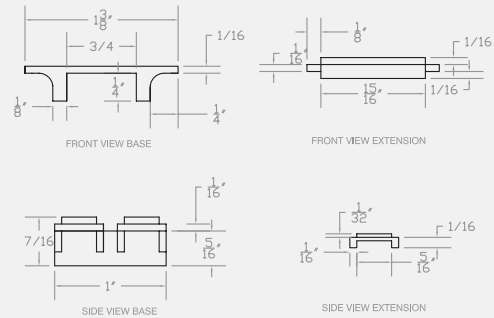



# PROLINE

## LOCKING METAL SPACERS

### SPECIFICATIONS

- Spacers are used to set the correct Cover at the correct elevation after finish tile or stone is installed. This is the same distance as from the waterproofing to top of the finished flooring material.
- Spacers are required with all PLD models.

PRODUCT NO.	DESCRIPTION	A LENGTH
SP1/2	Locking Metal Spacers	1/2"
SP1	Locking Metal Spacers	1"
SP1.5	Locking Metal Spacers	1-1/2"
SP1 3/4	Locking Metal Spacers	1-3/4"
SP2 1/2	Locking Metal Spacers	2-1/2"

\*See diagram on right



### FEATURES & MATERIALS

**Materials:** 18 Gauge 304 stainless steel.

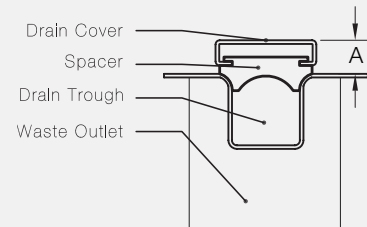
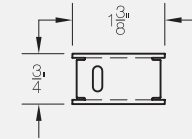



# PROLINE

## TAMPER RESISTANT DRAIN COVER

### SPECIFICATIONS

- Drain Cover is removable with Cover Removal Key
- Available in ten different standard lengths or custom lengths
- Drain cover may be cut on site to exact finished opening
- Spacers are required to hold the drain cover to the drain body
- Maximum Spacer height for tamper resistant drain cover is 1-3/4"

PRODUCT NO.	DESCRIPTION
N/A	Tamper Resistant Drain Cover
TMPS1/2	Tamper Resistant Screw for use with SP1/2
TMPS1-1/2	Tamper Resistant Screw for use with SP1-1/2
TMPS1-3/4	Tamper Resistant Screw for use with SP1-3/4
TMPS1	Tamper Resistant Screw for use with SP1

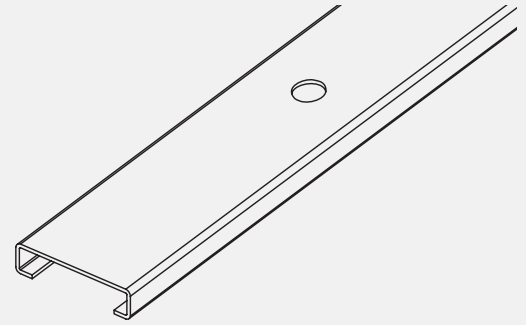
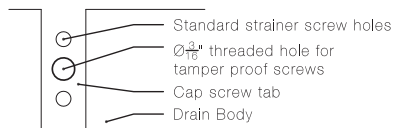
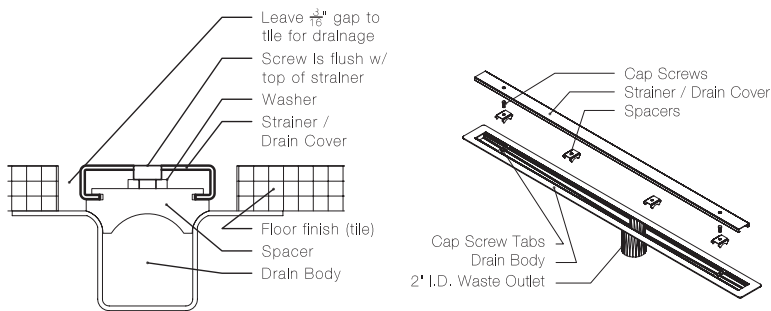

### FEATURES & MATERIALS

**Materials:** 18 Gauge 304 Stainless Steel

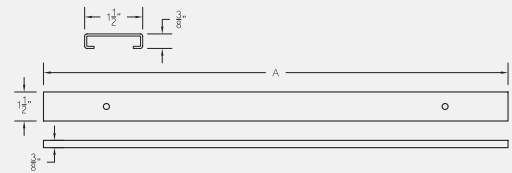





# PROLINE SINK DRAIN

## SPECIFICATIONS

- Sink Drain
- Key feature of the drain body is a fully-sloped trough that prevents standing water and solids being deposited into the trough
- 1.5" I.D. schedule 10 Steel Pipe waste outlet
- NOT SUITABLE AS A FLOOR DRAIN
- Height adjustability of drain cover with use of spacers for different thicknesses of finished material from 3/8" to 3/4". Custom spacers are available for finished material thicknesses from 1"-2 1/2"
- QuickDrain USA recommends the drain cover extend the entire length of the sink

PRODUCT NO.	HEIGHT ADJUSTABLE SPACERS	COVER LENGTH
PLD18S1	2	COVER18

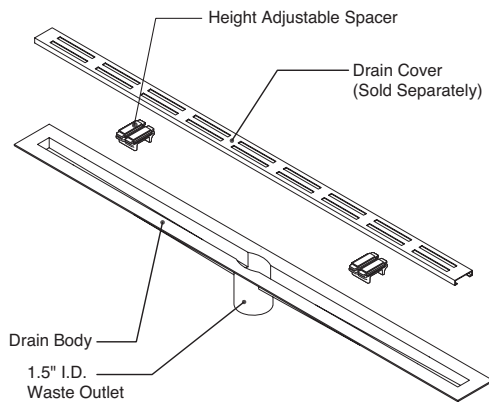

ProLine Sink Drain Assembly



## APPROVALS AND LISTINGS

Before installing QuickDrain USA system, check with your local building department/plumbing inspector to ensure compliance with the local building codes. QuickDrain USA LLC is not responsible for any conflicts with local building codes. QuickDrain USA LLC is not responsible for improper installation of any part of the assembly or the waterproofing membrane. Dimensions are subject to manufacturer's tolerance and can change without notice.

## DRAIN BODY INCLUDES

Height Adjustable Spacers

## REQUIRED PART (NOT INCLUDED)

### Drain Cover

Available in the following lengths: 18".

## FEATURES & MATERIALS

**Materials:** 18 Gauge 316L Stainless Steel

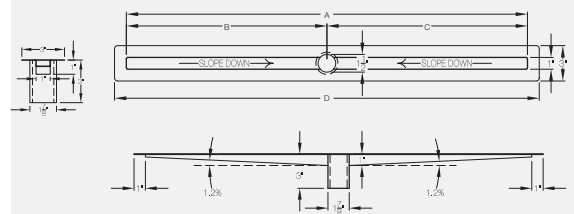

## DIMENSIONS (IN INCHES) SEE ABOVE DIAGRAM

**A:** 18

**C:** 9

**B:** 9

**D:** 20

















# COVERS

## COSMO COVER

### SPECIFICATIONS

- Cover is removable
- Available in twelve different standard lengths or custom length
- Cover can be cut on site to fit exact finish opening
- Spacers are required to hold the Cover to the Drain Body
- Available in Brushed or Polished Stainless Steel. Custom Finishes also available – inquire for details, lead times apply.
- QuickDrain USA™ Linear Drains and Covers are designed to span from Vertical to Vertical surface, which includes: Wall to another Vertical Wall, Wall to Curb, Wall to Glass Partition, or Wall to Glass Door.
- Cover must remain removable for maintenance and must never be grouted or caulked in place.

PRODUCT NO.	DESCRIPTION	A LENGTH
COSM018	Brushed Stainless Steel 	18"
COSM032	Brushed Stainless Steel 	32"
COSM040	Brushed Stainless Steel 	40"
COSM048	Brushed Stainless Steel 	48"
COSM056	Brushed Stainless Steel 	56"
COSM064	Brushed Stainless Steel 	64"
COSM072	Brushed Stainless Steel 	72"
COSM018-P	Polished Stainless Steel 	18"
COSM032-P	Polished Stainless Steel 	32"
COSM040-P	Polished Stainless Steel 	40"
COSM048-P	Polished Stainless Steel 	48"
COSM056-P	Polished Stainless Steel 	56"
COSM064-P	Polished Stainless Steel 	64"
COSM072-P	Polished Stainless Steel 	72"
COSM072-120	Polished Stainless Steel 	72-120"

**Note: Custom Finishes also available – inquire for details, lead times apply.**  
 \*See diagram on right

### COSMO DRAIN COVER - RESINOUS

### SPECIFICATIONS

- Drain Cover is removable
- Drain Cover cannot be cut on site

PRODUCT NO.	DESCRIPTION	A LENGTH
N/A	Cosmo Drain Cover - Resinous 	

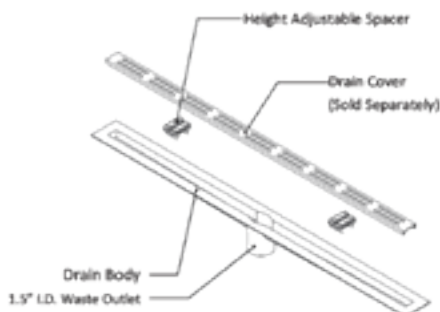

### FEATURES & MATERIALS

**Materials:** 18 Gauge 304 stainless steel.

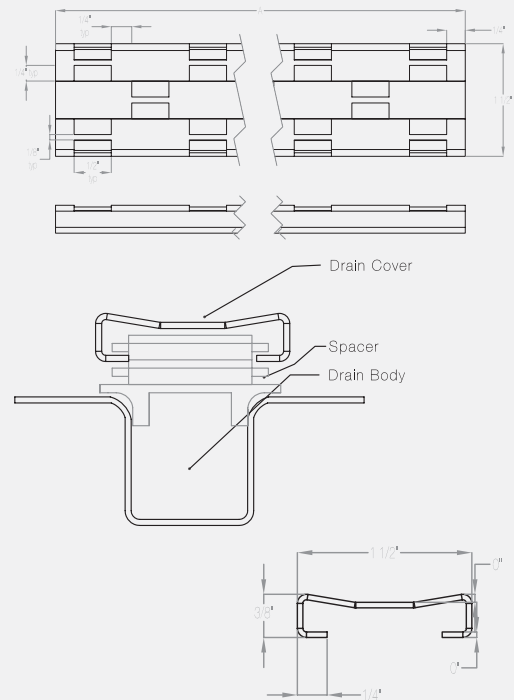

### FEATURES & MATERIALS

**Materials:** 18 Gauge 304 stainless steel.

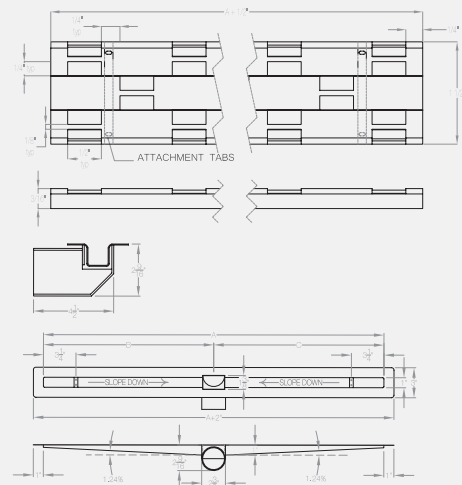

For more details, visit [www.quickdrainusa.com/quickdrain-submittals](http://www.quickdrainusa.com/quickdrain-submittals)



# COVERS

## LINES COVER

### SPECIFICATIONS

- Cover is removable
- Available in twelve different standard lengths or custom length
- Cover can be cut on site to fit exact finish opening
- Spacers are required to hold the Cover to the Drain Body
- Available in Brushed or Polished Stainless Steel. Custom Finishes also available – inquire for details, lead times apply.
- QuickDrain USA™ Linear Drains and Covers are designed to span from Vertical to Vertical surface, which includes: Wall to another Vertical Wall, Wall to Curb, Wall to Glass Partition, or Wall to Glass Door.
- Cover must remain removable for maintenance and must never be grouted or caulked in place.

PRODUCT NO.	DESCRIPTION		A LENGTH
LINES18	Brushed Stainless Steel		18"
LINES32	Brushed Stainless Steel		32"
LINES40	Brushed Stainless Steel		40"
LINES48	Brushed Stainless Steel		48"
LINES56	Brushed Stainless Steel		56"
LINES64	Brushed Stainless Steel		64"
LINES72	Brushed Stainless Steel		72"
LINES18-P	Polished Stainless Steel		18"
LINES32-P	Polished Stainless Steel		32"
LINES40-P	Polished Stainless Steel		40"
LINES48-P	Polished Stainless Steel		48"
LINES56-P	Polished Stainless Steel		56"
LINES64-P	Polished Stainless Steel		64"
LINES72-P	Polished Stainless Steel		72"
LINES72-120	Polished Stainless Steel		72-120"

**Note: Custom Finishes also available – inquire for details, lead times apply.**

\*See diagram on right

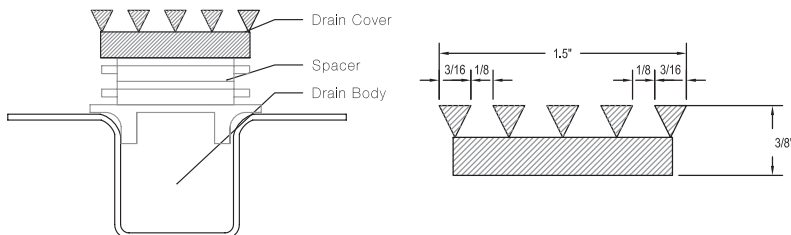

### FEATURES & MATERIALS

**Materials:** 18 Gauge 304 Stainless Steel

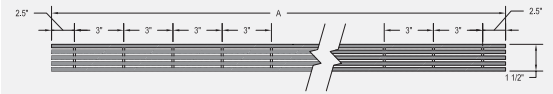

QUICKDRAIN



# COVERS

## STREAM COVER

### SPECIFICATIONS

- Cover is removable
- Available in twelve different standard lengths or custom length
- Cover can be cut on site to fit exact finish opening
- Spacers are required to hold the Cover to the Drain Body
- Available in Brushed Stainless Steel. Custom Finishes also available – inquire for details, lead times apply.
- QuickDrain USA™ Linear Drains and Covers are designed to span from Vertical to Vertical surface, which includes: Wall to another Vertical Wall, Wall to Curb, Wall to Glass Partition, or Wall to Glass Door.
- Cover must remain removable for maintenance and must never be grouted or caulked in place.

PRODUCT NO.	DESCRIPTION		A LENGTH
STREAM18	Stream Cover		18"
STREAM32	Stream Cover		32"
STREAM40	Stream Cover		40"
STREAM48	Stream Cover		48"
STREAM56	Stream Cover		56"
STREAM64	Stream Cover		64"
STREAM72	Stream Cover		72"

**Note: Custom Finishes also available – inquire for details, lead times apply.**

\*See diagram on right

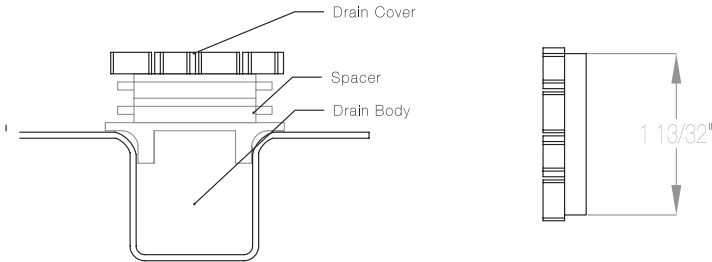

### FEATURES & MATERIALS

**Materials:** 18 Gauge 304 stainless steel.

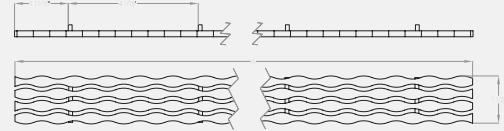



# COVERS

## TILE IN COVER

### SPECIFICATIONS

- Cover is removable
- Available in twelve different standard lengths or custom length
- Cover can be cut on site to fit exact finish opening
- Spacers are required to hold the Cover to the Drain Body
- Available in Brushed Stainless Steel. Custom Finishes also available – inquire for details, lead times apply.
- QuickDrain USA™ Linear Drains and Covers are designed to span from Vertical to Vertical surface, which includes: Wall to another Vertical Wall, Wall to Curb, Wall to Glass Partition, or Wall to Glass Door.
- Cover must remain removable for maintenance and must never be grouted or caulked in place.
- Be certain to place a spacer at each attachment point to minimize deflection
- QuickDrain USA does not recommend the use of the Tilein cover in a traffic or load-bearing location.

Tilein cover must be installed prior to floor tile to determine finished elevation

PRODUCT NO.	DESCRIPTION	A LENGTH
TILEIN18	Tile In Cover	18"
TILEIN32	Tile In Cover	32"
TILEIN40	Tile In Cover	40"
TILEIN48	Tile In Cover	48"
TILEIN56	Tile In Cover	56"
TILEIN64	Tile In Cover	64"
TILEIN72	Tile In Cover	72"

**Note: Custom Finishes also available – inquire for details, lead times apply.**

\*See diagram on right

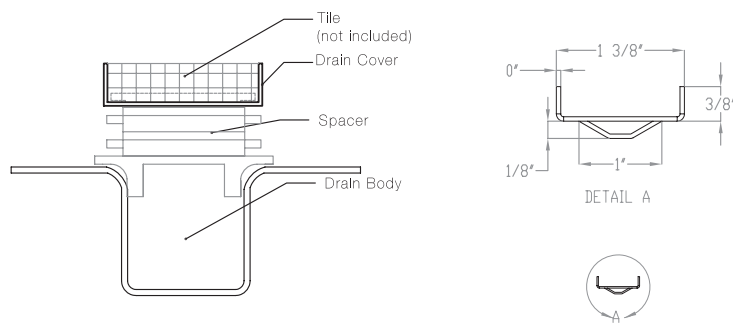

### FEATURES & MATERIALS

**Materials:** 18 Gauge 304 stainless steel.

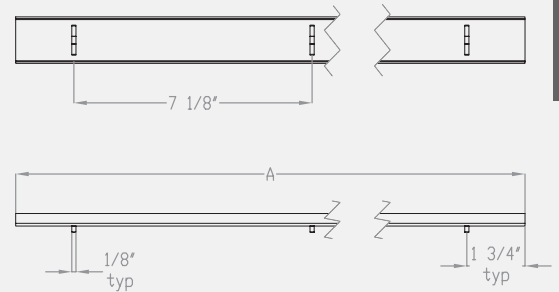



# COVERS ELEMENT COVER

### SPECIFICATIONS

- Removable
- Available in six different standard lengths
- Spacers are required to hold the cover to the drain body
- Can be used with both Showerline and Proline drains
- Can be cut on site to fit exact finished opening
- Height adjustable with use of spacers.
- Available in Brushed or Polished Stainless Steel. Custom Finishes also available – inquire for details, lead times apply.
- QuickDrain USA™ Linear Drains and Covers are designed to span from Vertical to Vertical surface, which includes: Wall to another Vertical Wall, Wall to Curb, Wall to Glass Partition, or Wall to Glass Door.
- Cover must remain removable for maintenance and must never be grouted or caulked in place.

PRODUCT NO.	DESCRIPTION	A LENGTH
ELEMENT32	Brushed Stainless Steel	32"
ELEMENT40	Brushed Stainless Steel	40"
ELEMENT42	Brushed Stainless Steel	48"
ELEMENT56	Brushed Stainless Steel	56"
ELEMENT64	Brushed Stainless Steel	64"
ELEMENT72	Brushed Stainless Steel	72"
ELEMENT32-P	Polished Stainless Steel	32"
ELEMENT40-P	Polished Stainless Steel	40"
ELEMENT42-P	Polished Stainless Steel	48"
ELEMENT56-P	Polished Stainless Steel	56"
ELEMENT64-P	Polished Stainless Steel	64"
ELEMENT72-P	Polished Stainless Steel	72"

**Note: Custom Finishes also available – inquire for details, lead times apply.**

\*See diagram on right



### APPROVALS AND LISTINGS

Before installing QuickDrain USA system, check with your local building department/plumbing inspector to ensure compliance with the local building codes. QuickDrain USA LLC is not responsible for any conflicts with local building codes. QuickDrain USA LLC is not responsible for improper installation of any part of the assembly or the waterproofing membrane. Dimensions are subject to manufacturer's tolerance and can change without notice.

### FEATURES & MATERIALS

**Materials:** 18 Gauge 304 stainless steel.





# COVERS

## HORIZONTAL COVER

### SPECIFICATIONS

- Removable
- Available in six different standard lengths
- Spacers are required to hold the cover to the drain body
- Can be used with both ShowerLine and ProLine drains
- Can be cut on site to fit exact finished opening
- Height adjustable with use of spacers.
- Available in Brushed or Polished Stainless Steel. Custom Finishes also available – inquire for details, lead times apply.
- QuickDrain USA™ Linear Drains and Covers are designed to span from Vertical to Vertical surface, which includes: Wall to another Vertical Wall, Wall to Curb, Wall to Glass Partition, or Wall to Glass Door.
- Cover must remain removable for maintenance and must never be grouted or caulked in place.
- Length adjustment of cover must be evenly trimmed on both sides.

PRODUCT NO.	DESCRIPTION	A LENGTH
HORIZONTAL32	Brushed Stainless Steel	32"
HORIZONTAL40	Brushed Stainless Steel	40"
HORIZONTAL42	Brushed Stainless Steel	48"
HORIZONTAL56	Brushed Stainless Steel	56"
HORIZONTAL64	Brushed Stainless Steel	64"
HORIZONTAL72	Brushed Stainless Steel	72"
HORIZONTAL32-P	Polished Stainless Steel	32"
HORIZONTAL40-P	Polished Stainless Steel	40"
HORIZONTAL42-P	Polished Stainless Steel	48"
HORIZONTAL56-P	Polished Stainless Steel	56"
HORIZONTAL64-P	Polished Stainless Steel	64"
HORIZONTAL72-P	Polished Stainless Steel	72"

**Note: Custom Finishes also available – inquire for details, lead times apply.**

\*See diagram on right



### APPROVALS AND LISTINGS

Before installing QuickDrain USA system, check with your local building department/plumbing inspector to ensure compliance with the local building codes. QuickDrain USA LLC is not responsible for any conflicts with local building codes. QuickDrain USA LLC is not responsible for improper installation of any part of the assembly or the waterproofing membrane. Dimensions are subject to manufacturer's tolerance and can change without notice.

### FEATURES & MATERIALS

**Materials:** 18 Gauge 304 stainless steel.

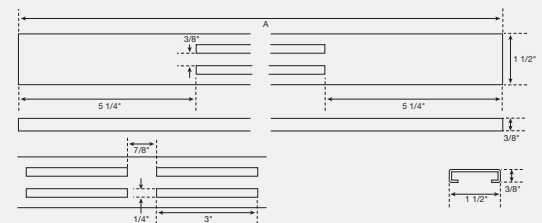



# COVERS

## VERTICAL COVER

### SPECIFICATIONS

- Removable
- Available in six different standard lengths
- Spacers are required to hold the cover to the drain body
- Can be used with ShowerLine and ProLine drains
- Can be cut on site to fit exact finished opening
- Height adjustable with use of spacers
- Available in Brushed or Polished Stainless Steel. Custom Finishes also available – inquire for details, lead times apply.
- QuickDrain USA™ Linear Drains and Covers are designed to span from Vertical to Vertical surface, which includes: Wall to another Vertical Wall, Wall to Curb, Wall to Glass Partition, or Wall to Glass Door.
- Cover must remain removable for maintenance and must never be grouted or caulked in place.

PRODUCT NO.	DESCRIPTION	A LENGTH
VERTICAL32	Brushed Stainless Steel	32"
VERTICAL40	Brushed Stainless Steel	40"
VERTICAL42	Brushed Stainless Steel	48"
VERTICAL56	Brushed Stainless Steel	56"
VERTICAL64	Brushed Stainless Steel	64"
VERTICAL72	Brushed Stainless Steel	72"
VERTICAL32-P	Polished Stainless Steel	32"
VERTICAL40-P	Polished Stainless Steel	40"
VERTICAL42-P	Polished Stainless Steel	48"
VERTICAL56-P	Polished Stainless Steel	56"
VERTICAL64-P	Polished Stainless Steel	64"
VERTICAL72-P	Polished Stainless Steel	72"

**Note: Custom Finishes also available – inquire for details, lead times apply.**

\*See diagram on right



### APPROVALS AND LISTINGS

Before installing QuickDrain USA system, check with your local building department/plumbing inspector to ensure compliance with the local building codes. QuickDrain USA LLC is not responsible for any conflicts with local building codes. QuickDrain USA LLC is not responsible for improper installation of any part of the assembly or the waterproofing membrane. Dimensions are subject to manufacturer's tolerance and can change without notice.

### FEATURES & MATERIALS

**Materials:** 18 Gauge 304 stainless steel.

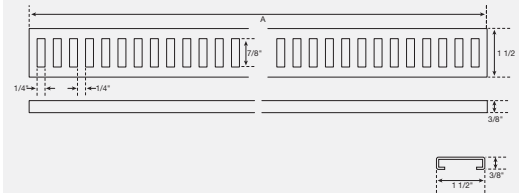





# SHOWERLINE

## ABS DRAIN BASE

### SPECIFICATIONS

The HOTMD23-ABS is designed for use in traditional shower pan installation. Using the countersunk holes, secure the flange base to the subfloor with an approved fastener. Shower pan drain shall have a solvent weld connection over 2" Sch. 40 DWV hub connection which conforms to ASTM D2665 (PVC) or D2661 (ABS). Strainer shall meet all necessary load and flow requirements for installations in shower areas.

PRODUCT NO.	DESCRIPTION
HOTMD23-ABS	ABS Drain Base



### APPROVALS AND LISTINGS

Uniform Plumbing Code (UPC®)  
National Plumbing Code of Canada  
International Plumbing Code (IPC®)  
ASME A112.18.2-2015/CSA B125.2-15

### FEATURES & MATERIALS

**Drain Base:** ABS

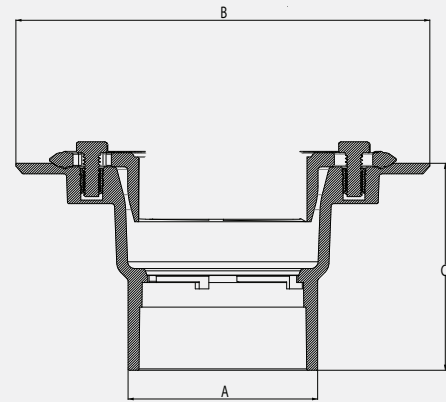

### DIMENSIONS

**A:** Hub Connection 2" Sch. 40  
**B:** Flange Diameter 5 7/8"

**C:** Base Height 2 7/8"



# SHOWERLINE

## PVC DRAIN BODY VERTICAL WASTE OUTLET

### SPECIFICATIONS

- Most important special feature is the internally sloped trough. This feature is a key to no stagnant water sitting in the trough any time and eliminates hard water build up
- Length adjustability of drain body with use of trough extensions (5" for each side, 10" total) to accommodate drain sizes from 24" - 72"
- Height adjustability of drain cover with use of spacers for different thicknesses of finish material from 3/8" to 3/4"
- Compatible to the following kinds of waterproofing: topical sheet waterproofing (QTS, Kerdi™, Noble TS™), topical liquid waterproofing (AquaDefense™, RedGard™, Hydro Ban™, Ardex 8+9™), hot mop, PolyVinyl Chloride (PVC) vinyl liner, rubber liner, Chlorinated PolyEthylene (CPE).
- Drain capacity for 2" outlet is 12 GPM in a shower pan with curb and 5 GPM in a shower pan without a curb at the entry. For 1.5" outlet it's 9 GPM and 3.5 GPM. (the actual volume is limited by the plumbing lines and P-trap).

PRODUCT NO.	HEIGHT ADJUSTABLE SPACERS	SCREWS
PVC2430D15, PVC2430D20	4	22
PVC3240D20	4	26
PVC4048D20	6	34
PVC4856D20	6	38
PVC5664D20	8	42
PVC6472D20	8	50

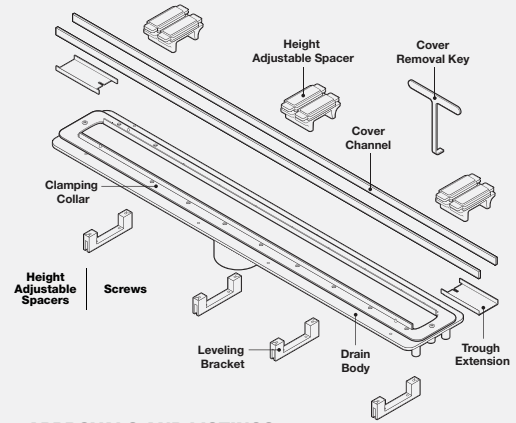
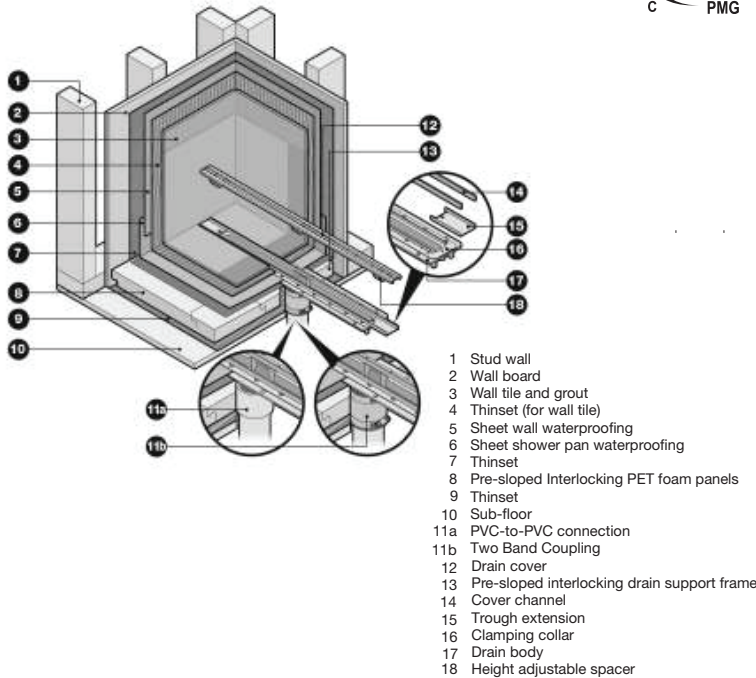

### APPROVALS AND LISTINGS

Before installing QuickDrain USA system, check with your local building department/plumbing inspector to ensure compliance with the local building codes. QuickDrain USA LLC is not responsible for any conflicts with local building codes. QuickDrain USA LLC is not responsible for improper installation of any part of the assembly or the waterproofing membrane. Dimensions are subject to manufacturer's tolerance and can change without notice.

### DRAIN ASSEMBLY INCLUDES

**PVC Parts:** Drain body (1), Leveling Brackets (4), Height Adjustable Spacers\*

**304 Stainless Steel Parts:** Clamping collar (1), Cover Channel (2), Trough Extension (2), Screws

**Other:** Cover Removal Key (2)

### REQUIRED PART (NOT INCLUDED)

#### Drain Cover

Available in the following lengths: 32", 40", 48", 56", 64" and 72".

#### QTS waterproofing sheet

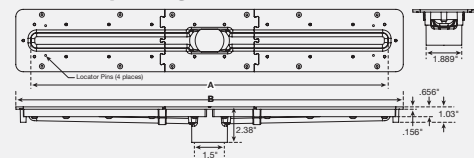

### DIMENSIONS SEE ABOVE DIAGRAM

Product No.	A	B
PVC2430D15	24"	26"
PVC3240D15	32"	34"
PVC4048D15	40"	42"
PVC4856D15	48"	50"
PVC5664D15	56"	58"
PVC6472D15	64"	66"

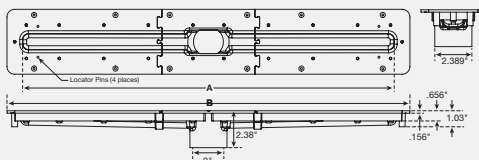

### DIMENSIONS SEE ABOVE DIAGRAM

Product No.	A	B
PVC2430D20	24"	26"
PVC3240D20	32"	34"
PVC4048D20	40"	42"
PVC4856D20	48"	50"
PVC5664D20	56"	58"
PVC6472D20	64"	66"

For more details, visit [www.quickdrainusa.com/quickdrain-submittals](http://www.quickdrainusa.com/quickdrain-submittals)



# SHOWERLINE

## PVC DRAIN BODY SIDE WASTE OUTLET

### SPECIFICATIONS

- Most important special feature is the internally sloped trough. This feature is a key to no stagnant water sitting in the trough any time and eliminates hard water build up
- Length adjustability of drain body with use of trough extensions (5" for each side, 10" total) to accommodate drain sizes from 24" - 72"
- Height adjustability of drain cover with use of spacers for different thicknesses of finish material from 3/8" to 3/4"
- Compatible to the following kinds of waterproofing: topical sheet waterproofing (QTS, Kerdi™, Noble TS™), topical liquid waterproofing (AquaDefense™, RedGard™, Hydro Ban™, Ardex 8+9™), hot mop, PolyVinyl Chloride (PVC) vinyl liner, rubber liner, Chlorinated PolyEthylene (CPE)
- Drain capacity for 2" outlet is 12 GPM in a shower pan with curb and 5 GPM in a shower pan without a curb at the entry. For 1.5" outlet it's 9 GPM and 3.5 GPM. (the actual volume is limited by the plumbing lines and P-trap).

PRODUCT NO.	HEIGHT ADJUSTABLE SPACERS	SCREWS
PVC2430D15-SWO, PVC2430D20-SWO	4	22
PVC3240D20-SWO	4	26

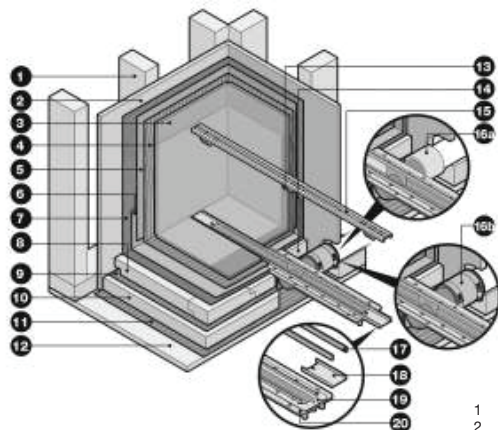

- Stud wall
- Wall board
- Wall tile and grout
- Thinset (for wall tile)
- Sheet wall waterproofing
- Sheet shower pan waterproofing
- Thinset
- Pre-sloped interlocking PET foam panels
- Thinset
- Flat foam panel
- Thinset
- Sub-floor
- Height adjustable spacer
- Pre-sloped interlocking drain support frame
- Drain cover
- 16a PVC-to-PVC connection
- 16b Two Band Coupling
- 17 Cover channel
- 18 Trough extension
- 19 Clamping collar
- 20 Drain body

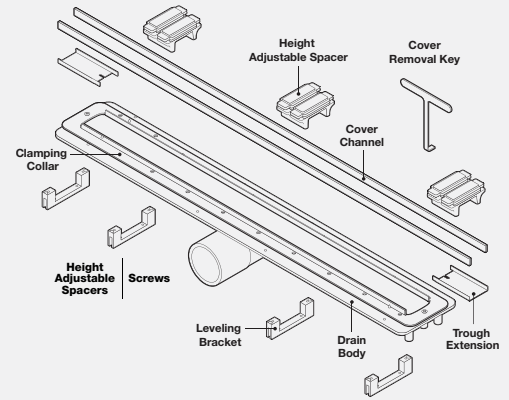

### APPROVALS AND LISTINGS

Before installing QuickDrain USA system, check with your local building department/plumbing inspector to ensure compliance with the local building codes. QuickDrain USA LLC is not responsible for any conflicts with local building codes. QuickDrain USA LLC is not responsible for improper installation of any part of the assembly or the waterproofing membrane. Dimensions are subject to manufacturer's tolerance and can change without notice.

### DRAIN ASSEMBLY INCLUDES

**PVC Parts:** Drain body (1), Leveling Brackets (4), Height Adjustable Spacers

**304 Stainless Steel Parts:** Clamping collar (1), Cover Channel (2), Trough Extension (2), Screws

**Other:** Cover Removal Key (2)

### REQUIRED PART (NOT INCLUDED)

#### Drain Cover

Available in the following lengths: 32", 40", 48", 56", 64" and 72".

#### QTS waterproofing sheet

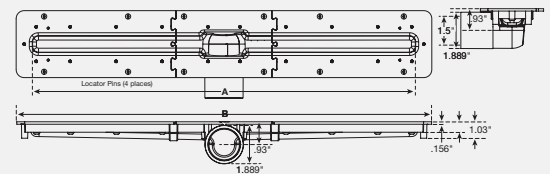

DIMENSIONS SEE ABOVE DIAGRAM

Product No.	A	B
PVC2430D15-SWO	24"	26"

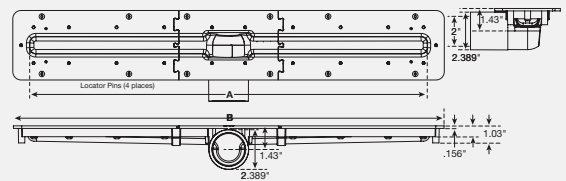

DIMENSIONS SEE ABOVE DIAGRAM

Product No.	A	B
PVC2430D20-SWO	24"	26"
PVC3240D20-SWO	32"	34"

For more details, visit [www.quickdrainusa.com/quickdrain-submittals](http://www.quickdrainusa.com/quickdrain-submittals)



# SHOWERLINE

## TWO BAND COUPLING

### SPECIFICATIONS

- Drain, Waste and Vent Use Only.
- 2" CI, PL or ST to 2" CI, PL, ST

PRODUCT NO.	DESCRIPTION
QD3000-22	Two Band Coupling



### APPROVALS AND LISTINGS

ASTM C1460 and ASTM C564.

### FEATURES & MATERIALS

**Gasket/Material:** Rubber

**Clamp/Shield:** All 300 SS

**Installation Torque:** 60 in-lb

**Temperature Range:** -30 F to 180 F





# SHOWERLINE

## QUICKLINER TS WATERPROOFING MEMBRANE

### SPECIFICATIONS

- 78" wide sheet of waterproofing pan liner, sold by the linear foot.
- Two outer layers of polypropylene spunlace non-woven material sandwiching an inner layer of waterproof polyethylene membrane.
- 0.6 mm thick. Easily creased into inside corners.
- Suitable for thin-bed shower waterproofing - No curing - Install tile immediately upon drying of thinset setting material.

PRODUCT NO.	DESCRIPTION
QTS78	Quickliner TS Waterproofing Membrane

### CHEMICAL PROPERTIES

Chemical Properties	Resistance After Storage Over 7 Days At Room Temp. In Following Chemicals	+ = Resistant 0 = Weakened - = Non-Resistant
Hydrochloric acid 3%	Internal	+
Sulphuric acid 35%	INTERNAL	+
Citric acid 100 g/l	INTERNAL	+
Lactic acid 5%	INTERNAL	+
Potassium hydroxide 3% / 20%	INTERNAL	+ / +
Sodium hypochlorite 0.3 g/l	INTERNAL	+
Salt water (20 g/l sea water salt)	INTERNAL	+



### APPROVALS AND LISTINGS

UPC 5130  
ANSI A118.10-2008  
ICC-ES PMG-1105

### FEATURES & MATERIALS

**Outer layers:** polypropylene spunlace non-woven material

**Inner layer:** waterproof polyethylene membrane

### PHYSICAL PROPERTIES

Physical Properties (approx.)	Din	Value
Burst Pressure: Max.	Internal	3.7 BAR
Breaking Load Longitudinal	DIN EN ISO 527-3	139N / 15MM
Breaking Load Lateral	DIN EN ISO 527-3	42N / 15MM
Extension Break Longitudinal	DIN EN ISO 527-3	52%
Extension Break Lateral	DIN EN ISO 527-3	182%
Power Absorption At 25% Elasticity Lateral	DIN EN ISO 527-3	1.5N / MM
Power Absorption At 50% Elasticity Lateral	DIN EN ISO 527-3	1.7N / MM
Resistance To Tearing Longitudinal	DIN EN 12310-2	54N
Resistance To Tearing Lateral	DIN EN 12310-2	160N
Resistance To Water Pressure	DIN EN 1928 (VER. B)	< 1.5 BAR
UVv-Resistance: Min.	DIN EN ISO 4892-2	500 H
Moisture Vapor Resistance Air Equivalent (Sd)	DIN EN 1931	> 85 M
BONDING STRENGTH	DIN EN 1348	> 0.4 N / MM SQ



# SHOWERLINE

## WATERPROOF CURB COVER

### SPECIFICATIONS

- Made of QuickLiner TS waterproofing membrane material
- Preformed to fit over our 2" wide SLCURB Form material
- Easily installed using QDMUS Sealant

PRODUCT NO.	DESCRIPTION
QTSCC	Waterproof Curb Cover

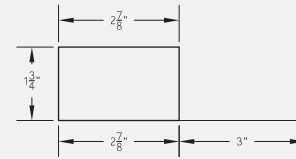
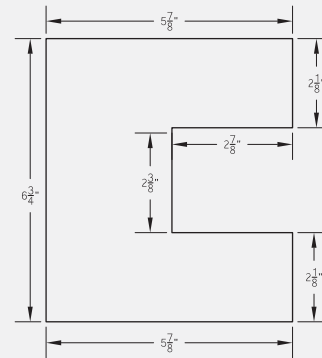

## WATERPROOFING MEMBRANE INSIDE CORNER

### SPECIFICATIONS

- Made of QuickLiner TS waterproofing membrane material
- Preformed to fit 90 degree inside corners
- Covers and waterproofs any inside corner in the shower pan
- Easily installed using QDMUS Sealant

PRODUCT NO.	DESCRIPTION
QTSIC	Waterproofing Membrane Inside Corner

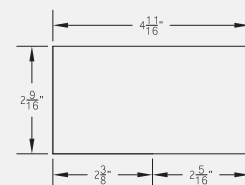
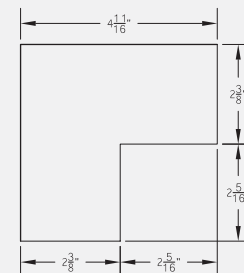
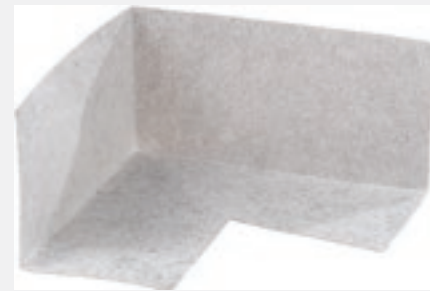

For more details, visit [www.quickdrainusa.com/quickdrain-submittals](http://www.quickdrainusa.com/quickdrain-submittals)



# SHOWERLINE

## QUICKLINER TS WATERPROOF MEMBRANE OUTSIDE CORNER

### SPECIFICATIONS

- Made of QuickLiner TS waterproofing membrane material
- Preformed to fit 90 degree outside corners
- Covers and waterproofs any outside corner in the shower pan
- Easily installed using QDMUS Sealant

PRODUCT NO.	DESCRIPTION
QTSOC	Quickliner TS Waterproof Membrane Outside Corner

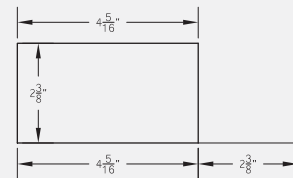
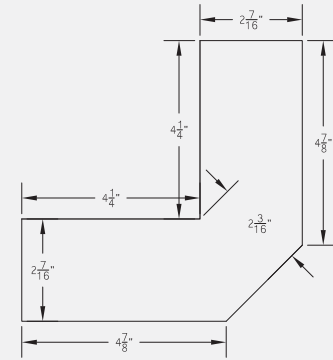

## 2" SHOWERLINE DRAIN CONNECTOR

### SPECIFICATIONS

- ShowerLine Drain Connector 2"
- Used for connecting multiple PVC drains

PRODUCT NO.	DESCRIPTION
SLDC2	2" ShowerLine Drain Connector



### FEATURES & MATERIALS

**Material:** 26 Gauge 304L stainless steel

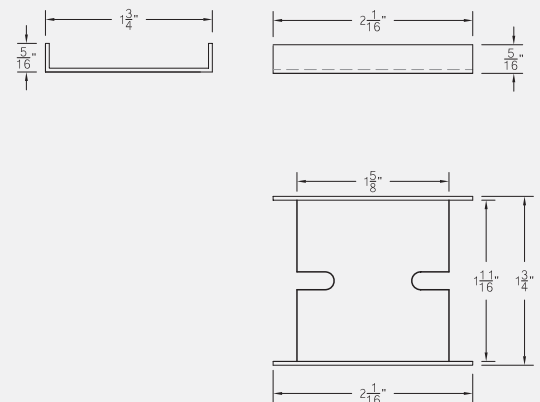

For more details, visit [www.quickdrainusa.com/quickdrain-submittals](http://www.quickdrainusa.com/quickdrain-submittals)



# SHOWERLINE

## 4" SHOWERLINE DRAIN CONNECTOR

### SPECIFICATIONS

- ShowerLine Drain Connector 4"
- Used for connecting multiple PVC drains

PRODUCT NO.	DESCRIPTION
SLDC4	4" ShowerLine Drain Connector



### FEATURES & MATERIALS

**Material:** 26 Gauge 304L stainless steel

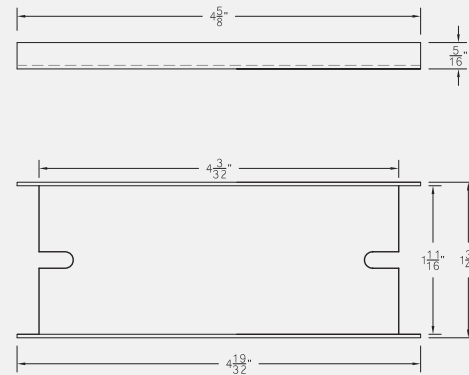

## SHOWERLINE TROUGH EXTENSION

### SPECIFICATIONS

- Protects membrane and funnels all water to drain trough when strainer is oversized.
- Can be trimmed on site to accommodate exact finish opening.
- Works with all strainer types.

PRODUCT NO.	DESCRIPTION
SLDE	ShowerLine Trough Extensions

### FEATURES & MATERIALS

**Material:** 26 Gauge 304L stainless steel

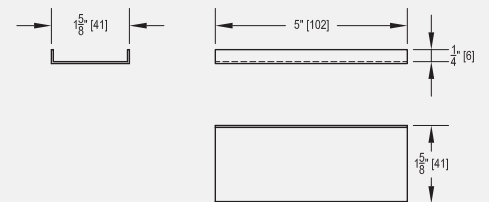

For more details, visit [www.quickdrainusa.com/quickdrain-submittals](http://www.quickdrainusa.com/quickdrain-submittals)





# SHOWERLINE

## LIQUID WATERPROOFING KITS

### SPECIFICATIONS

- Liquid waterproofing accessories for use with any liquid waterproofing: Aqua Defense, Hydroban, 3295, Ardex 8+9, RedGard
- Made of Non-Woven Polyester fabric
- Used to bridge joints and connections in the shower pan

QUANTITY INCLUDED IN KIT				
KIT PRODUCT NO.	CURB COVERS	OUTSIDE CORNERS	INSIDE CORNERS	REINFORCEMENT FABRIC
SLLWP	2	-	4	1
SLLWP-ADA*	-	2	2	1

\*For ADA or curbless shower installations.



### APPROVALS AND LISTINGS

Before installing QuickDrain USA system, check with your local building department/plumbing inspector to ensure compliance with the local building codes. QuickDrain USA LLC is not responsible for any conflicts with local building codes. QuickDrain USA LLC is not responsible for improper installation of any part of the assembly or the waterproofing membrane. Dimensions are subject to manufacturer's tolerance and can change without notice.

### WATERPROOFING KIT INCLUDES

- Non Woven Polyester Curb Covers
- Non Woven Polyester Outside Corners
- Non Woven Polyester Inside Corners
- Non Polyester Reinforcement Fabric



# SHOWERLINE FLAT PANEL

### SPECIFICATIONS

- Is made of extruded rigid PET (polyethylene terephthalate) plastic foam. It is strong yet lightweight, non-reactive, economical, and shatterproof.
- Chemically stable, UV resistant and suitable for both interior and exterior use
- Can be used with both sheet and liquid topical waterproofing
- Speed and consistency of installation
- Eliminates the need for traditional mud bed installations
- Lightweight, durable with high compressive strength
- Interlocking design, can be quickly and easily modified to size and shape of on site conditions
- 100% post Consumer recycled and fully recyclable.
- Custom curb sizes available

PRODUCT NO.	DESCRIPTION
SLFP1760	Flat Panel



### APPROVALS AND LISTINGS

Before installing QuickDrain USA system, check with your local building department/plumbing inspector to ensure compliance with the local building codes. QuickDrain USA LLC is not responsible for any conflicts with local building codes. QuickDrain USA LLC is not responsible for improper installation of any part of the assembly or the waterproofing membrane. Dimensions are subject to manufacturer's tolerance and can change without notice.  
IAPMO PS-106-2013

### SHOWERLINE PAN INCLUDES

Flat Panel (SLFP1760)

### SUITABLE SUBSTRATES (INTERIOR ONLY)

- Concrete
- Exterior Glue Plywood
- Cement backer board
- OSB Or Avantech

### APPLICATIONS / USES

- Interior and exterior use
- Industrial, commercial and residential showers
- Gang showers
- Pet Showers

### FEATURES & MATERIALS

**Materials:** PET (polyethylene terephthalate) plastic foam

**Compressive Strength:** 145 PSI

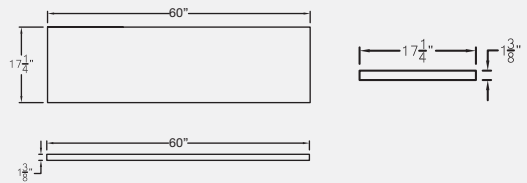

For more details, visit [www.quickdrainusa.com/quickdrain-submittals](http://www.quickdrainusa.com/quickdrain-submittals)



# SHOWERLINE PAN KITS

## SPECIFICATIONS

- Is made of extruded rigid PET (polyethylene terephthalate) plastic foam. It is strong yet lightweight, non-reactive, economical, and shatterproof.
- Chemically stable, UV resistant and suitable for both interior and exterior use
- Can be used with both sheet and liquid topical waterproofing
- Speed and consistency of installation
- Eliminates the need for traditional mud bed installations
- Lightweight, durable with high compressive strength
- Interlocking design, can be quickly and easily modified to size and shape of on site conditions
- 100% post Consumer recycled and fully recyclable.
- Custom curb sizes available
- PET Pan Kits can be customized upon request

KIT PRODUCT NO.	PRODUCTS & QUANTITY INCLUDED IN KIT		
	DRAIN SUPPORT FRAME	SLQS1652	SLQS852
SLPAN32	SLDSF32	2	-
SLPAN40	SLDSF40	2	1
SLPAN48	SLDSF48	3	-
SLPAN56	SLDSF56	3	1
SLPAN64	SLDSF64	4	-
SLPAN72	SLDSF72	4	1

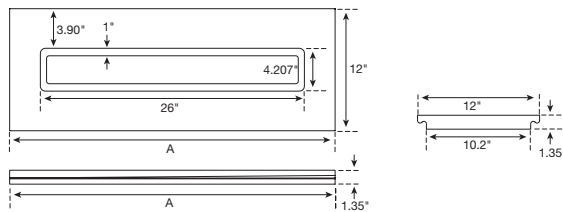

## DIMENSIONS

Model	A
SLDSF32	32"
SLDSF40	40"
SLDSF48	48"
SLDSF56	56"
SLDSF64	64"
SLDSF72	72"



## APPROVALS AND LISTINGS

Before installing QuickDrain USA system, check with your local building department/plumbing inspector to ensure compliance with the local building codes. QuickDrain USA LLC is not responsible for any conflicts with local building codes. QuickDrain USA LLC is not responsible for improper installation of any part of the assembly or the waterproofing membrane. Dimensions are subject to manufacturer's tolerance and can change without notice. IAPMO PS-106-2013

## SHOWERLINE PAN INCLUDES

- Drain Support Frame
- Quick Slope (SLQS1652, SLQS852)
- Curb (SL Curb)
- Screws (5)

## SUITABLE SUBSTRATES (INTERIOR ONLY)

- Concrete
- Exterior Glue Plywood
- Cement backer board
- OSB Or Avantech

## APPLICATIONS / USES

- Interior and exterior use
- Industrial, commercial and residential showers
- Gang showers
- Pet Showers

## FEATURES & MATERIALS

**Materials:** PET (polyethylene terephthalate) plastic foam  
**Compressive Strength:** 145 PSI

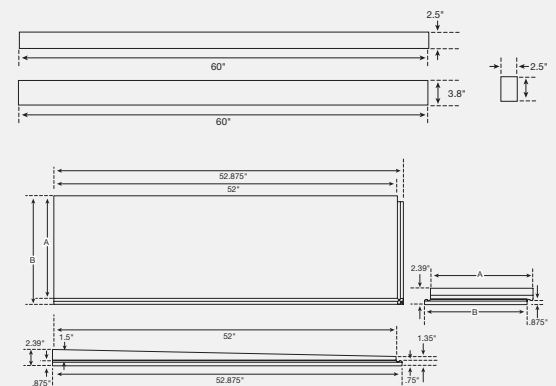

## DIMENSIONS

Model	A	B
SLQS1652	16"	16.875"
SLQS852	8"	-

For more details, visit [www.quickdrainusa.com/quickdrain-submittals](http://www.quickdrainusa.com/quickdrain-submittals)



# SHOWERLINE PAN KITS

## SPECIFICATIONS

- ShowerLine pan is made of extruded rigid PET (polyethylene terephthalate) plastic foam. It is strong yet lightweight, non-reactive, economical, and shatterproof.
- Chemically stable, UV resistant and suitable for both interior and exterior use
- Can be used with both sheet and liquid topical waterproofing
- Speed and consistency of installation
- Eliminates the need for traditional mud bed installations
- Lightweight, durable with high compressive strength
- Interlocking design, can be quickly and easily modified to size and shape of on site conditions
- 100% post Consumer recycled and fully recyclable.
- Custom curb sizes available

KIT PRODUCT NO.	PRODUCTS & QUANTITY INCLUDED IN KIT			
	DRAIN SUPPORT FRAME	SLQS1652	SLFP1760	CURB
SLPAN32-SWO	1	2	2	1

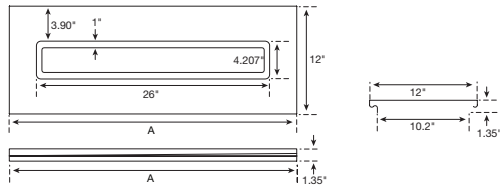

## DIMENSIONS

Model	A
SLDSF32	32"
SLDSF40	40"
SLDSF48	48"
SLDSF56	56"
SLDSF64	64"
SLDSF72	72"

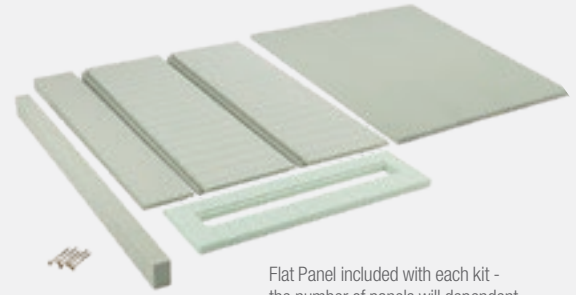
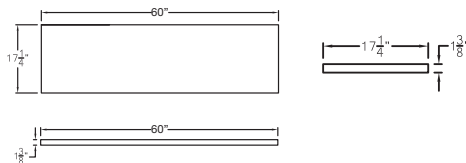

Flat Panel included with each kit - the number of panels will dependent on size of overall showerpan.

## APPROVALS AND LISTINGS

Before installing QuickDrain USA system, check with your local building department/plumbing inspector to ensure compliance with the local building codes. QuickDrain USA LLC is not responsible for any conflicts with local building codes. QuickDrain USA LLC is not responsible for improper installation of any part of the assembly or the waterproofing membrane. Dimensions are subject to manufacturer's tolerance and can change without notice. IAPMO PS-106-2013

## SHOWERLINE PAN INCLUDES

- Flat Panel (SLFP1760)
- Drain Support Frame (DSF)
- Quick Slope (SLQS1652)
- Curb (SL Curb)
- Screws (5)

## SUITABLE SUBSTRATES (INTERIOR ONLY)

- Concrete
- Exterior Glue Plywood
- Cement backer board
- OSB Or Avantech

## APPLICATIONS / USES

- Interior and exterior use
- Industrial, commercial and residential showers
- Gang showers
- Pet Showers

## FEATURES & MATERIALS

**Materials:** PET (polyethylene terephthalate) plastic foam  
**Compressive Strength:** 145 PSI

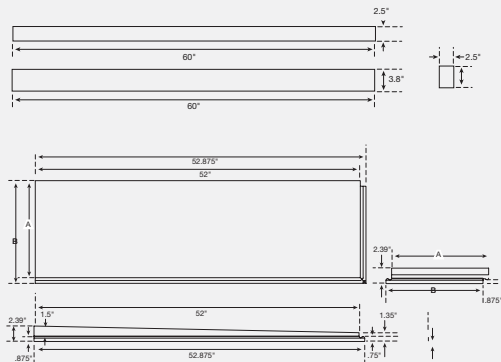

## DIMENSIONS

Model	A	B
SLQS1652	16"	16.875"
SLQS852	8"	-

For more details, visit [www.quickdrainusa.com/quickdrain-submittals](http://www.quickdrainusa.com/quickdrain-submittals)



# SHOWERLINE PAN KITS

## SPECIFICATIONS

- Is made of extruded rigid PET (polyethyleneterephthalate) plastic foam. It is strong yet lightweight, non-reactive, economical, and shatterproof
- Chemically stable, UV resistant and suitable for both interior and exterior use
- Can be used with both sheet and liquid topical waterproofing
- Speed and consistency of installation
- Eliminates the need for traditional mud bed installations
- Lightweight, durable with high compressive strength
- Can be quickly and easily modified to size and shape of on site conditions
- 100% Post Consumer recycled and fully recyclable

PRODUCTS & QUANTITY INCLUDED IN KIT	
KIT PRODUCT NO.	SLQSADA
SLPANADA48	3
SLPANADA64	4

SLPANADA4874, SLPANADA48100

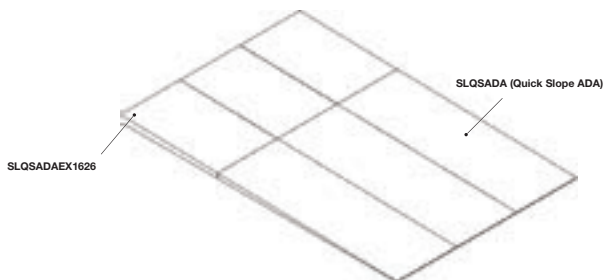

PRODUCTS & QUANTITY INCLUDED IN KIT			
KIT PRODUCT NO.	SLQSADA	SLQSADAEX1626	SLQSADAEX1652
SLPANADA4874	3	3	-
SLPANADA48100	3	-	3

SLPANADA6474, SLPANADA64100

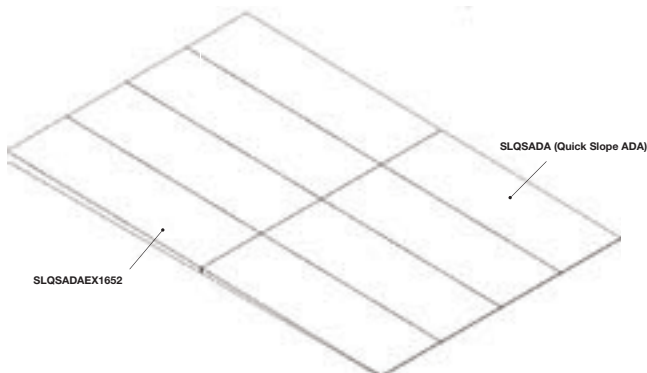

PRODUCTS & QUANTITY INCLUDED IN KIT			
KIT PRODUCT NO.	SLQSADA	SLQSADAEX1626	SLQSADAEX1652
SLPANADA6474	4	4	-
SLPANADA64100	4	-	4



Before installing QuickDrain USA system, check with your local building department/plumbing inspector to ensure compliance with the local building codes. QuickDrain USA LLC is not responsible for any conflicts with local building codes. QuickDrain USA LLC is not responsible for improper installation of any part of the assembly or the waterproofing membrane. Dimensions are subject to manufacturer's tolerance and can change without notice. IAPMO PS-106-2013

## SUITABLE SUBSTRATES (INTERIOR ONLY)

Concrete  
Exterior Glue Plywood  
Cement backer board  
OSB Or Avantech

## APPLICATIONS / USES

Interior and exterior use  
Industrial, commercial and residential showers  
Gang showers  
Pet Showers

## FEATURES & MATERIALS

**Materials:** PET (polyethylene terephthalate) plastic foam  
**Compressive Strength:** 145 PSI

### SLQSADA (Quick Slope ADA)

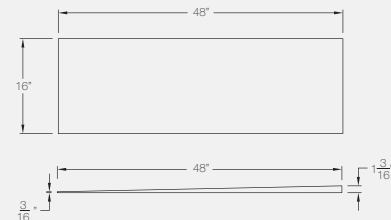

### SLQSADAEX1652

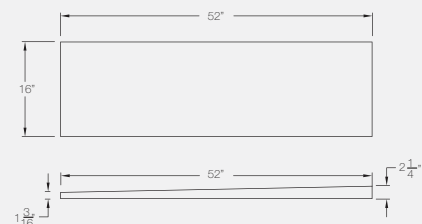

### SLQSADAEX1626

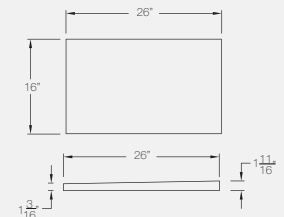



# SHOWERLINE

## QUICKSLOPE

### SPECIFICATIONS

- Chemically stable, UV resistant and suitable for both interior and exterior use
- Can be used with both sheet and liquid topical waterproofing
- Speed and consistency of installation
- Eliminates the need for traditional mud bed installations
- Lightweight, durable with high compressive strength
- 100% Post consumer recycled and fully recyclable

PRODUCT NO.	DESCRIPTION
SLQS852	QuickSlope



local building department/plumbing inspector to ensure compliance with the local building codes. QuickDrain USA LLC is not responsible for any conflicts with local building codes. QuickDrain USA LLC is not responsible for improper installation of any part of the assembly or the waterproofing membrane. Dimensions are subject to manufacturer's tolerance and can change without notice.  
IAPMO PS-106-2013

### SUITABLE SUBSTRATES (INTERIOR ONLY)

- Concrete
- Exterior Glue Plywood
- Cement backer board
- OSB Or Avantech

### APPLICATIONS / USES

- Interior and exterior use
- Industrial, commercial and residential showers
- Gang showers
- Pet Showers

### FEATURES & MATERIALS

**Compressive Strength:** 145 PSI

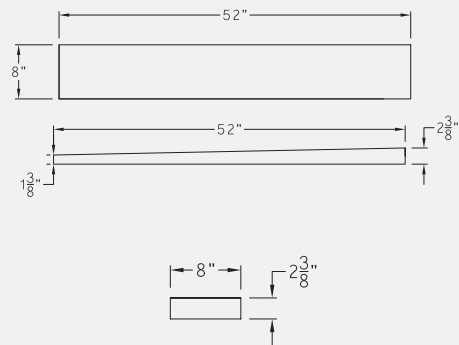

For more details, visit [www.quickdrainusa.com/quickdrain-submittals](http://www.quickdrainusa.com/quickdrain-submittals)



# SHOWERLINE QUICKSLOPE

## SPECIFICATIONS

- Chemically stable, UV resistant and suitable for both interior and exterior use
- Can be used with both sheet and liquid topical waterproofing
- Speed and consistency of installation
- Eliminates the need for traditional mud bed installations
- Lightweight, durable with high compressive strength
- 100% Post consumer recycled and fully recyclable

PRODUCT NO.	DESCRIPTION
SLQS1652	QuickSlope



## APPROVALS AND LISTINGS

Before installing QuickDrain USA system, check with your local building department/plumbing inspector to ensure compliance with the local building codes. QuickDrain USA LLC is not responsible for any conflicts with local building codes. QuickDrain USA LLC is not responsible for improper installation of any part of the assembly or the waterproofing membrane. Dimensions are subject to manufacturer's tolerance and can change without notice.  
IAPMO PS-106-2013

## SUITABLE SUBSTRATES (INTERIOR ONLY)

Concrete  
Exterior Glue Plywood  
Cement backer board  
OSB Or Avantech

## APPLICATIONS / USES

Interior and exterior use  
Industrial, commercial and residential showers  
Gang showers  
Pet Showers

## FEATURES & MATERIALS

**Compressive Strength:** 145 PSI

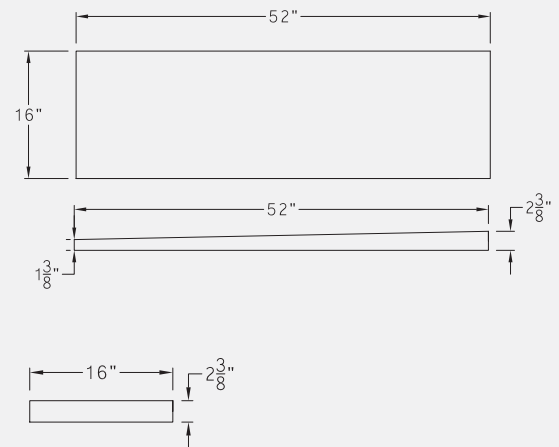

For more details, visit [www.quickdrainusa.com/quickdrain-submittals](http://www.quickdrainusa.com/quickdrain-submittals)



# SHOWERLINE ADA PANEL

### SPECIFICATIONS

- Chemically stable, UV resistant and suitable for both interior and exterior use
- Can be used with both sheet and liquid topical waterproofing
- Speed and consistency of installation
- Eliminates the need for traditional mud bed installations
- Lightweight, durable with high compressive strength
- 100% Post consumer recycled and fully recyclable

PRODUCT NO.	DESCRIPTION
SLQSADA	ADA Panel



### APPROVALS AND LISTINGS

Before installing QuickDrain USA system, check with your local building department/plumbing inspector to ensure compliance with the local building codes. QuickDrain USA LLC is not responsible for any conflicts with local building codes. QuickDrain USA LLC is not responsible for improper installation of any part of the assembly or the waterproofing membrane. Dimensions are subject to manufacturer's tolerance and can change without notice.  
IAPMO PS-106-2013

### SUITABLE SUBSTRATES (INTERIOR ONLY)

- Concrete
- Exterior Glue Plywood
- Cement backer board
- OSB Or Avantech

### APPLICATIONS / USES

- Interior and exterior use
- Industrial, commercial and residential showers
- Gang showers
- Pet Showers

### FEATURES & MATERIALS

**Compressive Strength:** 145 PSI

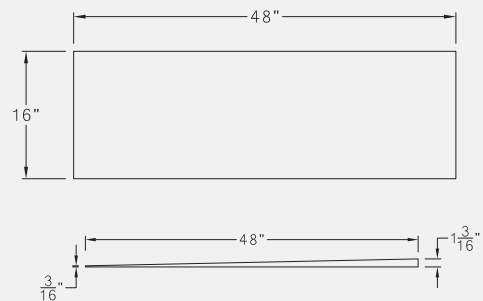

For more details, visit [www.quickdrainusa.com/quickdrain-submittals](http://www.quickdrainusa.com/quickdrain-submittals)





# SHOWERLINE

## SHEET WATERPROOFING KITS



### SPECIFICATIONS

- Waterproofing pan liner membrane and accessories used to create a watertight shower pan

KIT PRODUCT NO.	PRODUCTS AND QUANTITY INCLUDED IN KIT				
	WATERPROOF MEMBRANE	CURB COVERS	OUTSIDE CORNERS	INSIDE CORNERS	QDMUS
SLSWP32	48" x 78"	2	–	4	1
SLSWP40	56" x 78"	2	–	4	1
SLSWP48	64" x 78"	2	–	4	1
SLSWP56	72" x 78"	2	–	4	1
SLSWP64	80" x 78"	2	–	4	1
SLSWP72	88" x 78"	2	–	4	1
SLSWP-ADA	60" x 78"	–	2	2	1



### APPROVALS AND LISTINGS

Before installing QuickDrain USA system, check with your local building department/plumbing inspector to ensure compliance with the local building codes. QuickDrain USA LLC is not responsible for any conflicts with local building codes. QuickDrain USA LLC is not responsible for improper installation of any part of the assembly or the waterproofing membrane. Dimensions are subject to manufacturer's tolerance and can change without notice.  
ANSI A118.10  
IAPMO Listing #8483

### WATERPROOFING KIT INCLUDES

- Membrane
- Curb Covers (for curbed shower pans)
- Outside Corners (for ADA, curbless shower pans)
- Inside Corners
- QDMUS (sealant)



# RETROFIT DRAIN BODY

## SPECIFICATIONS

- No recess in the subfloor required
- Fits within the thickness of 3/8" tile + thin set
- Most important special feature is the internally sloped trough. This feature is a key to no stagnant water sitting in the trough any time and eliminates hard water build up
- Use with any kind of topical waterproofing: topical sheet waterproofing (QTS, Kerdi™, Noble TST™), topical liquid waterproofing (AquaDefense™, RedGard™, Hydro Ban™, Ardex 8+9™).

PRODUCT NO.	DESCRIPTION
RETROD66	Drain Body

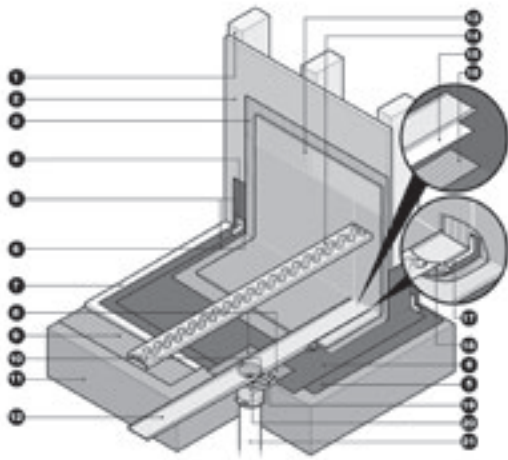

- |  |                                       |
|--|---------------------------------------|
| 1 Stud Wall                            | 13 Wall Tile and Grout                |
| 2 Backer Board                         | 14 Drain Cover                        |
| 3 Thinset (for wall tile)              | 15 Transition Tape (under drain body) |
| 4 Reinforcing Fabric                   | 16 Thinset (under drain body)         |
| 5 First Layer of Liquid Waterproofing  | 17 Modified Urethane Sealant          |
| 6 Second Layer of Liquid Waterproofing | 18 Tile Edging                        |
| 7 Slope                                | 19 Modified Urethane Sealant          |
| 8 Pipe Collar                          | 20 No-Hub Coupling                    |
| 9 Thinset                              | 21 Pipe Extension                     |
| 10 Weep Holes                          |                                       |
| 11 Concrete Subfloor                   |                                       |
| 12 Drain Body                          |                                       |

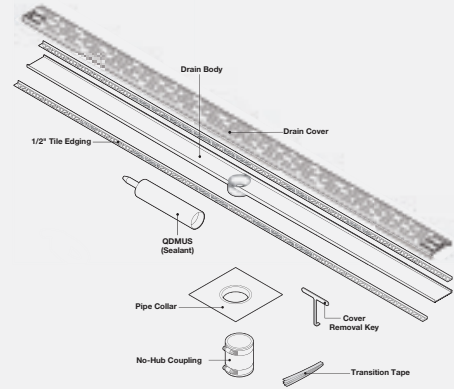

## APPROVALS AND LISTINGS

Before installing QuickDrain USA system, check with your local building department/plumbing inspector to ensure compliance with the local building codes. QuickDrain USA LLC is not responsible for any conflicts with local building codes. QuickDrain USA LLC is not responsible for improper installation of any part of the assembly or the waterproofing membrane. Dimensions are subject to manufacturer's tolerance and can change without notice. IAPMO PS-106-2013

## DRAIN ASSEMBLY INCLUDES

- Drain Body (1)
- Tile Edging (2)
- Drain Cover (1)
- Pipe Collar (1)
- No-hub Coupling (1)
- QDMUS (sealant)
- Transition Tape (1)
- Other: Cover Removal Key (2)

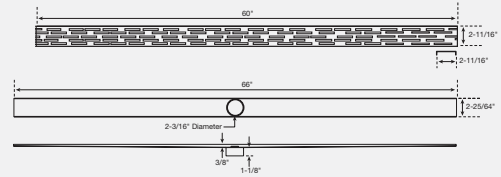



# POWER OF ONE

**#1 in the industry.** Oatey® is the number one source for purchasing the leading brands in the plumbing and home improvement industries.

**One call does it all.** Only Oatey brings you the plumbing industry's best brands in one source. Making it easy to purchase any product across all our brands on one invoice, in one shipment.

# Oatey®



deliver quality. build trust. improve lives.