



Amazon Fashion

Seller Imaging Guidelines

Clothing & Accessories

SPRING 2021

Welcome to Amazon Fashion

At Amazon Fashion, we are constantly striving to reinvent and improve the e-commerce experience to make Amazon the preferred online shopping destination for fashion customers.

We invite you to join us in this journey.



To get started, this guide will walk through expectations for product imagery used in **all apparel & accessories** sold on Amazon. Detailed **technical requirements, best practices, general information** about how images are used and examples of engaging and multi-faceted images are enclosed.

Amazon seeks to create an elevated, consistent & inclusive experience for all who shop at Amazon Fashion.

INDEX

		DESCRIPTION	PAGE
Imaging Basics		General Terminology	5
		Where Images are Displayed	6 – 7
		Types of Images	8 – 9
		Number of Images x Types of Shots	10
Amazon Site Standards		Main Image Requirements – DO's	12
		Main Image Requirements – DON'Ts	13
		Prohibited Images	14
		Mains v. Variants	15
Best Practices		Diversity & Inclusion	17 – 18
		Hair	19
		Styling	20
Technical Requirements		High Resolution & Zoom	22
		File Specifications & Naming	23
		On-Model Lighting	24 – 26
		Off-Model Lighting	27 – 28
Main Image Examples	ON-FIGURE	Dresses; One-piece Garments; Robes & Nightgowns; Suits & Tuxedos; Sleep Sets; Sweaters, Jackets, & Outerwear (Below the Knee)	30
		Sweaters, Jackets, & Outerwear (Above the Knee); One-piece Swimsuits & Rash Guards; Tops & Tees	31
		Trousers, Jeans, & Pants; Skirts; Shorts; Leggings & Pajama Bottoms	32
		Bras & Sports Bras; Swim Tops; Swimming Bottoms; Underwear	33 – 34
	OFF-FIGURE	All Kids, Baby, & Accessories; Multi-packs & Sets	35 – 37
Alternate Image Examples		Additional Image Examples	39 – 44



Imaging Basics

ASIN : **Amazon Standard Item Number.** This refers to a specific product sold on Amazon.

SKU : Stock Keeping Unit. An industry term used in retail that refers to a specific item being sold.

Parent : A specific color or pattern variation of a product that is used as the primary image set. You must supply a parent Main image. This image typically populates the search page.

Child : Used to show the product in a different color or pattern variation than the parent for a SKU. You must supply a child Main image that matches the color or pattern variation for every item you sell.

Main : The first image displayed for customers. All products, including parent and child SKUs, must have a Main image. All color or pattern variations should include a child Main image of that specific color or pattern. **There are specific requirements for Main images that differ from variant images.**

Variant : Any image in an image set that is not the primary image displayed first. Variants are used to highlight other aspects of the product, such as detail, material, movement, styling options, and more.

On-figure : Or “on-model.” An image or group of images that features a model.

Off-figure : Or “off-model.” An image or group of images without a model. Types of off-figure images can be flat or laydown, on a ghost mannequin, or on a traditional visible mannequin. **Note:** mannequins are not allowed in product images.

**.Main, .PTO__, .FL__,
.SWCH, etc.**

File naming convention for uploading different types of images: ex: MAIN, PT01, PT02, PT03, FL01, SWCH, ...

WHERE IMAGES ARE DISPLAYED

THIS GUIDE IS FOR INFORMATIONAL PURPOSES ONLY.

Product images can be found across the Amazon store. A few common areas they appear are:

Search Page

The Main image displays in search results.

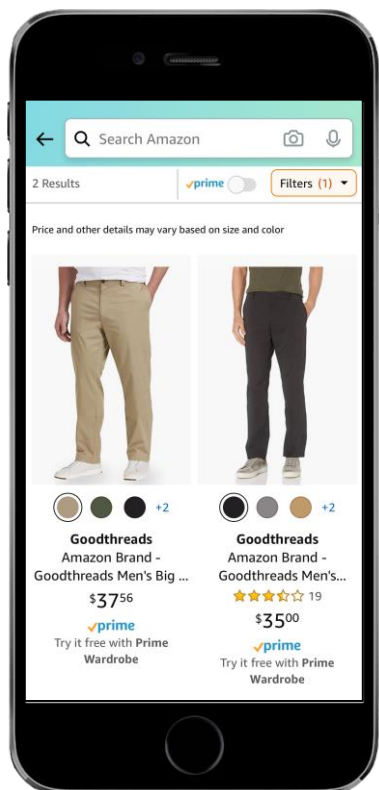

Browse Page

The Main image displays in browse widgets on category-specific pages.

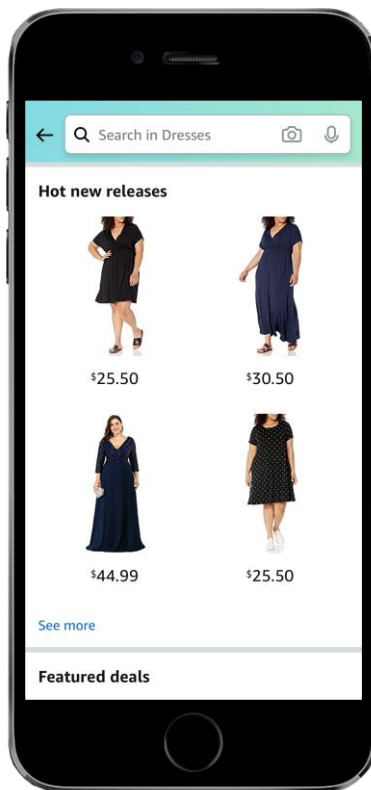

Detail Page

The product page is where customers view full product detail and images.



High-quality images incorporating **Amazon's imaging standards** found in this guide are eligible for consideration in **Amazon-created advertising** throughout Amazon Fashion's store.

Amazon.com Home Page

Advertisement in Amazon.com front page advertising widgets

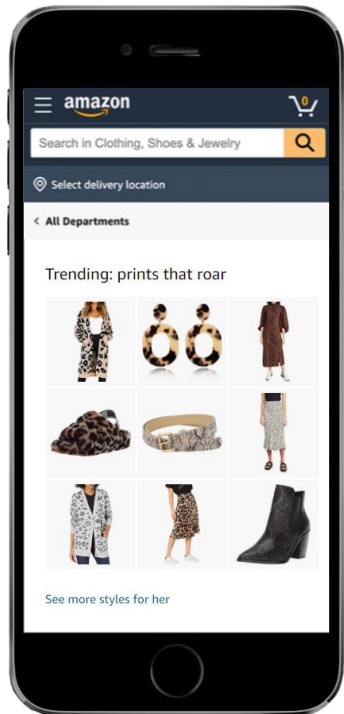

Fashion Sales Events

Inclusion in Fashion Sales Events

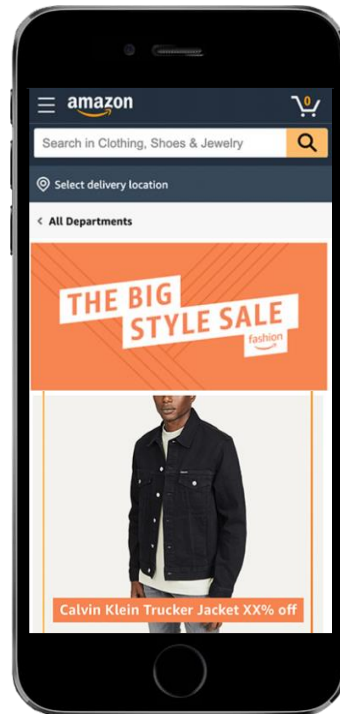

Styling Ideas Widget

Inclusion into Styling Ideas widget in Detail Pages

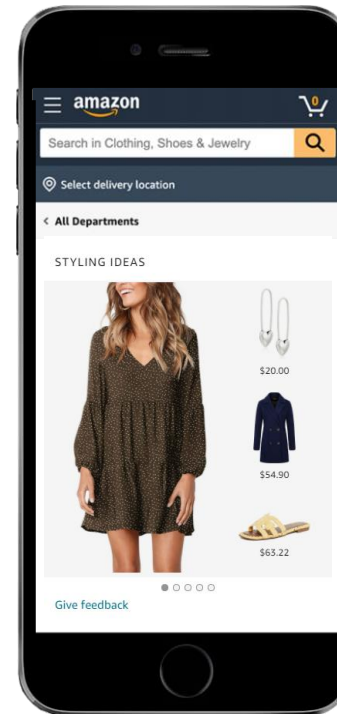

Curated Programs

Curated sites, like Customer's Most Loved, that highlight best sellers.

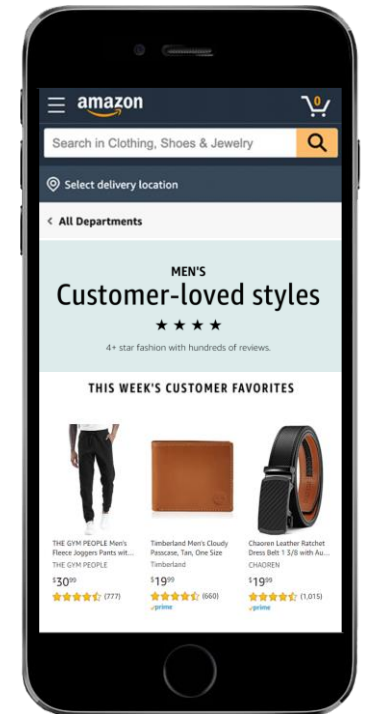

Amazon displays several images for each product in the catalog. You should provide several high resolution images for your products so customers can connect with your brand voice and make informed buying decisions.

Listings with missing Main images or Main images that fail to meet requirements as outlined on the following pages may result in the removal of your ASIN from search.



Main

Only one Main image is used per parent product. You must supply a parent Main image.

Child

Used to show the product in the specific color or pattern for the given child SKU.

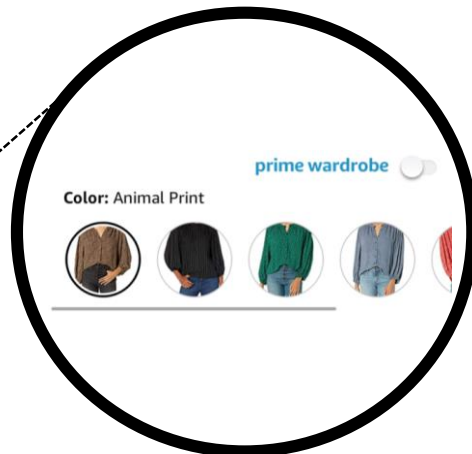

Variants

Used to show different views of the product to help clarify use, detail, fabric, cut, etc. You can supply up to six alternate images, for a total of seven images for each parent or child SKU.

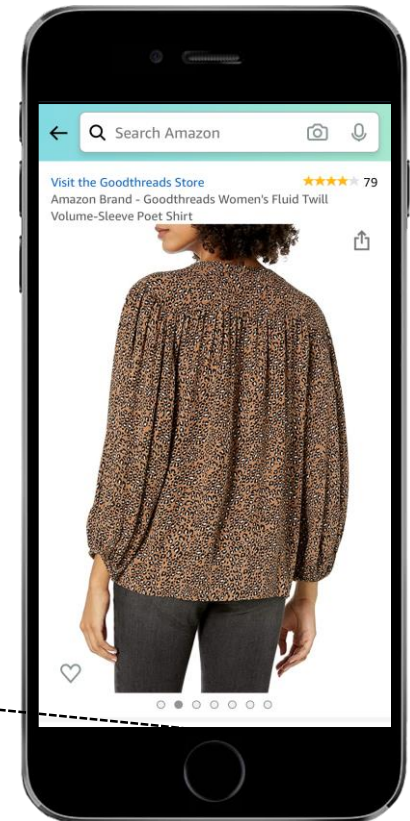
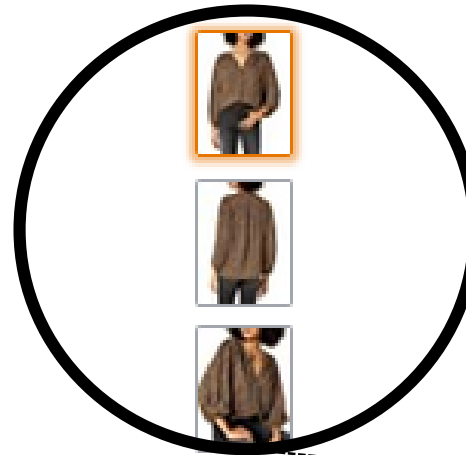

TYPES OF IMAGES

THIS GUIDE IS FOR INFORMATIONAL PURPOSES ONLY.

Parent Example

Main Image

Front – On-Figure



MAIN

Back – On-Figure



PT01

Detail – On-Figure



PT02

Styled – On-Figure



PT03

Laydown – Off-Figure



FL01

Flat Detail – Off-Figure



PT13

Variants (Alternate Images)

←-----> FILE NAMES

The **Parent** is a specific color or pattern variation of a product that is used as the primary image set. Another color or pattern variation of the product is a **Child**.

Every image set must have a single **Main** image, which is displayed first and used in Search & Browse. An image set can also have **Variants**, or alternate images, which are used to highlight other aspects of the product, such as detailing, material, movement, styling options, brand voice, and more.

One of the variants may also be a short video.

Child Examples

Main Images

Same product in different colors or patterns.



Variant images are recommended for each child as well.

NUMBER OF IMAGES X TYPES OF SHOTS

THIS GUIDE IS FOR INFORMATIONAL PURPOSES ONLY.

Based on customer studies, each product listing should have a **minimum of 5 and maximum 7 images** to enable an informed purchasing decision. These should include a **clear front and back image of the item**, as well as additional details showcasing all angles of your product.

To help customers discover new styles while connecting with your brand, consider adding a **styled shot** of inspiration, **multiple models** with various fits, a **close-up** of details, and a **video** to exhibit fabric and movement.

MAIN - REQUIRED

EXTREMELY IMPORTANT

← VALUABLE ADDITIONAL IMAGES →



Front On-Figure



Back On-Figure

Detail On-Figure



Styled On-Figure



Flat Off-figure



Detail Off-Figure



Styled & Detail Shots

MINIMUM OF **FIVE** & MAXIMUM OF **SEVEN** IMAGES PER PRODUCT.
A VARIANT MAY ALSO BE A SHORT VIDEO.

High-quality images incorporating Amazon's imaging standards found in this guide are eligible for consideration in Amazon-created advertising throughout Amazon Fashion's store.



Amazon Site Standards



Product **Main images** have specific requirements.

- ✔ MAIN images **must** have a **pure white background** (RGB Value 255, HEX Value #FFFFFF).
- ✔ MAIN images **must** be a **single product**, not stacks of images containing multiple products (except multipacks/sets).
- ✔ The product **must** fill **at least 85%** of the image area.
- ✔ Visible hair **should** fall **behind the shoulder** and not cover any part of the product.
- ✔ All **adult apparel** **should** be imaged on-model.
- ✔ All **kids, baby, accessories, multipacks & sets** **should** be off-model.
- ✔ Amazon accepts JPEG (.jpg) and TIFF (.tif). **JPEG is preferred.**

FAILURE TO MEET THESE REQUIREMENTS MAY RESULT IN THE REMOVAL OF YOUR ASIN FROM SEARCH.

MAIN IMAGE REQUIREMENTS – DON'Ts

THIS GUIDE IS FOR INFORMATIONAL PURPOSES ONLY.

❌ Product **Main** images **must not** contain any of the following:



Gray backgrounds



Food, drink, handbags, accessories, or props not included with purchase



Child or baby models; **all kids & baby items must be off-model**



Models kneeling, leaning, or lying down.



Multiple product views in a single image



Visible mannequins



Ghost mannequins



Promotional text such as "sale" or "free shipping" (use the Manage Promotions tool instead)



Logo, text, graphics, or other badging not part of the product



Showing packaging, brands, or swing tags

✘ Prohibited product images **of any kind must not** contain any of the following:



Shots of underwear, swimwear, or leotard products on child or baby models are strictly prohibited & subject to removal.



Images that display nudity or sexually suggestive images are prohibited and subject to removal.



Images of products that look second-hand or slightly used are prohibited.

FAILURE TO MEET THESE PROHIBITIONS WILL RESULT IN THE REMOVAL OF YOUR ASIN FROM SEARCH.

MAINS V. VARIANTS

Unlike Variant images, Main images have specific requirements, which were previously detailed. Images displayed throughout this guide are provided to show examples within a product's image set, including both Mains and Variants.

Example differences you may observe:

- Main images must always have a white background; Variants may have a different background.
- Main images will be shown from the nose-down; Variants may show a full face.
- Main images must have the product fill at least 85% of the frame; Variants may be further zoomed in or out.
- Main images must not have props; Variants may be fully styled with props included.

EXAMPLES: MAIN IMAGES



EXAMPLES: VARIANT IMAGES

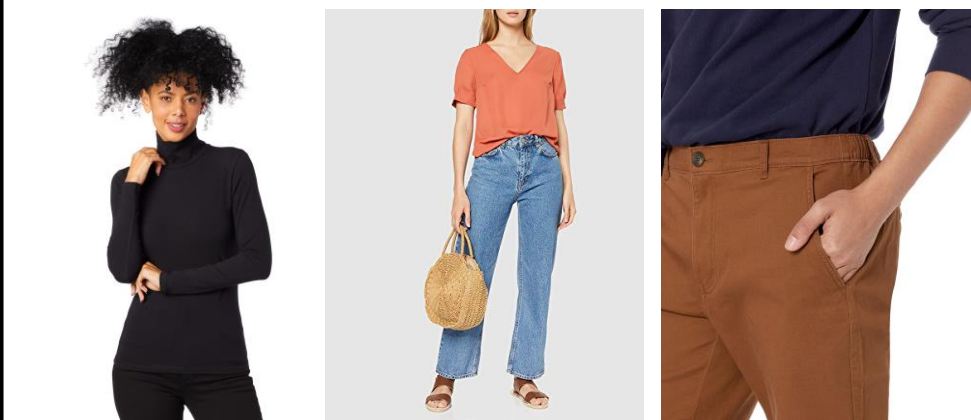



Best Practices



AMAZON VALUES ALL FORMS OF DIVERSITY, INCLUDING BUT NOT LIMITED TO SIZE, GENDER EXPRESSION, PHYSICAL ABILITY, RACE/ETHNICITY, AND AGE.

The models you use to represent your products should reflect the diversity of Amazon's customer base.

MODEL DIVERSITY & INCLUSION

THIS GUIDE IS FOR INFORMATIONAL PURPOSES ONLY.

Diversity should feel genuine.

Allow the clothing to remain the primary focus while also celebrating the distinct characteristics of our diverse customer base.



Hair enhances the outfit & brand personality.

Be sure to keep hair behind the shoulders so focus remains on the clothing, but also use hair types, textures, color, and styling to show individuality. Because Main images will be displayed at half-face, accentuate physical diversity characteristics that will remain in frame.



STYLING

THIS GUIDE IS FOR INFORMATIONAL PURPOSES ONLY.

The fit and styling of clothing is also a great opportunity to accentuate diversity while highlighting your brand voice. Especially in the variant images, express a product's story with stylistic choices that inspire and resonate with our diverse customer base.



Styling helps showcase diversity.



Technical Requirements

HIGH RESOLUTION & ZOOM

THIS GUIDE IS FOR INFORMATIONAL PURPOSES ONLY.

When you submit a **high-resolution image**, customers can zoom in on your product, and this has been proven to **increase customer trust and sales**. The minimum size requirement below enables this zoom function.

When you submit clothing product images, they **must** be:

1. At least **1,600 pixels** in height
2. Images must not exceed 10,000 pixels on the longest side.
3. **High-resolution at 72 dpi** (dots per inch)



**70% OF
CUSTOMERS
SHOP USING
THEIR MOBILE
OR TABLET**

SMALL
SCREEN,
BIG
DETAILS



FAQs

What are the recommended camera settings for high-resolution images? → F8 – f11, 400iso, 1/160 to 1/250 shutter speed

What are the recommended export settings for high-resolution images? → 8 bit JPEG, PNG-24 (optimal web viewing), interlaced

FILE SPECIFICATIONS & NAMING

THIS GUIDE IS FOR INFORMATIONAL PURPOSES ONLY.

Each image that you upload requires specific file requirements and naming assigned to it in order to ensure that the image maps to our site properly.

Image File Requirements:

- ✓ File format as JPG or PNG (JPG preferred).
- ✓ Color profile as RGB or CMYK (RGB is preferred because CMYK can display tonal variations when shown on the website).
- ✓ Resolution at least 72 dpi.
- ✓ Videos must be in a MOV or MP4 file format (MP4 is preferred).

The file name is composed of the **product identifier**, the **variant code**, and the image type **file extension**.

BOOSAMPLE.PT02.jpg

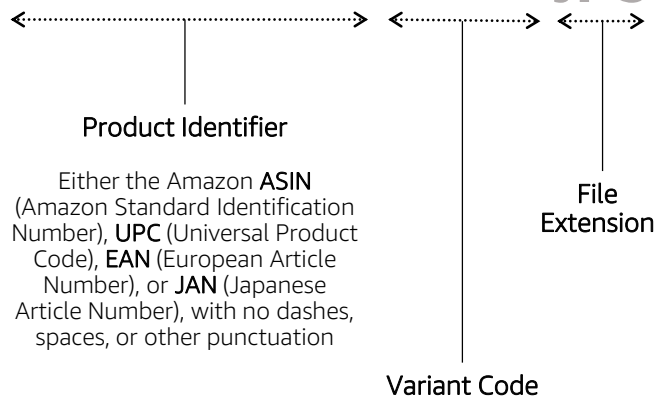

Example

Valid Variant Codes:

.MAIN

The primary image of an ASIN is called the **Main**. This image is **required** and represents an item in the search results and browse pages. It is the first image the customer will see when they click into the detail page.

.PT__

You can upload additional product images beyond the Main. These alternate or **variant** images are named **PT** images and **must** adhere to the following naming convention: **PT(zero)1, PT02, PT03, PT04, etc.** PT images may feature additional angles, configurations, product details, or environmental shots. These images are optional, but **highly recommended**.

.FL__

For products imaged on-figure, we recommend producing an off-figure alternate with the naming convention: **FL01**

Variant code (bolded) in full file name:

BOOSAMPLE.FL01.jpg

Studio-style Imaging is encouraged to showcase your product in natural or soft continuous light. The following outlines imaging basics for on-model photography. Avoid heavily retouched images and filters.

Recommended equipment:



- Full-frame digital camera with a minimum 12 MP
- 3x lights with stands (2 for the background, 1 for subject)
- Pure white background
- 2x white bounce cards
- Gray card
- Image editing software such as Adobe Photoshop, Lightroom, or Phase One

Recommended setup:

- 1 Set up your seamless background (if you are shooting full length, extend the seamless paper onto the ground).
- 2 Set up two lights, one on either side of the white background at around the height of your subject's chest, and set them back approximately 4 feet from the background.

Point the lights at a 45-degree angle to the background (angled towards the center of the background).

- 3 Place a center mark on the floor approximately 4 feet from where you placed the background lights. Take care not to mark your seamless background (if you are shooting head-to-toe). This will be where your model will stand.

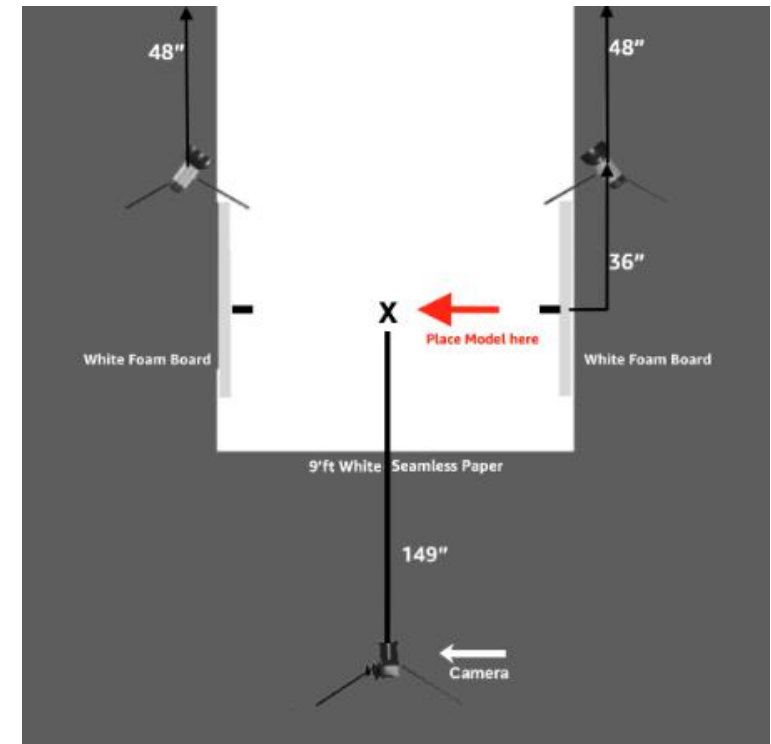

4 Set up your main light. This is going to light your subject. This should be placed approximately 12-13 feet from the subject, at around the height of your subject's head, and set at a 45-degree angle to the subject.

5 Place the 2 white bounce cards on either side of your subject (approximately 4 feet from the subject), taking care not to block the light coming from your main light.

6 Now you are ready to set the lighting power levels. Place your gray card on a stand at chest height on the subject mark.

7 Starting with the background lights, set both lights' power equally, and capture an image of the background.

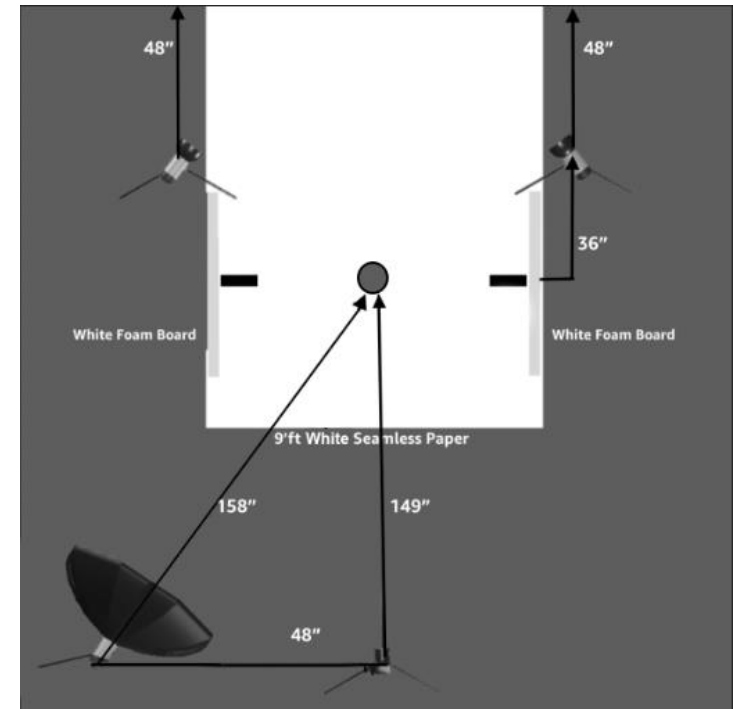
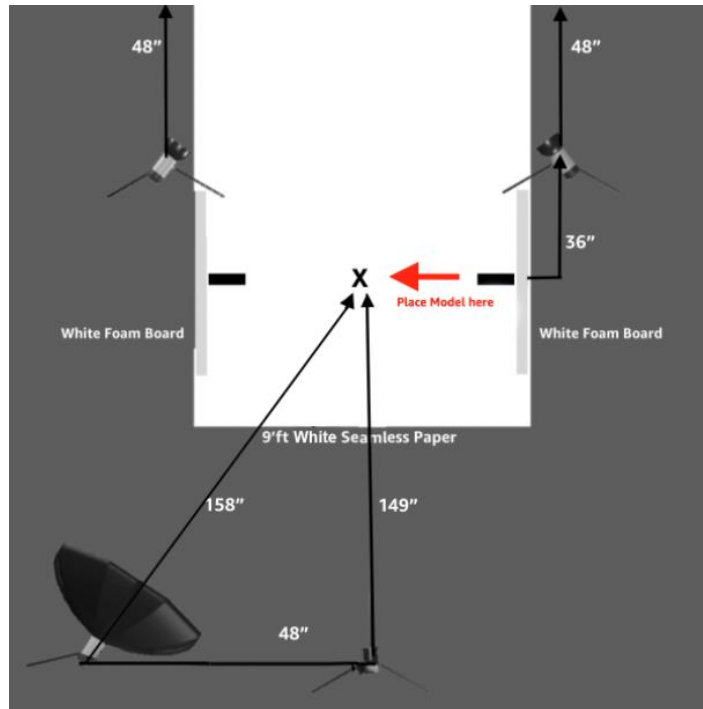

8 Adjust the power until the coverage of the background is even all the way across the area that will be in your image.

9 Import this image into your editing software. You are looking for pure white - #ffffff color RGB value is (255,255,255). If you don't have the tools necessary to do this, ensure that the background is pure white and your camera is set to Auto.

- 10 Turn on the main light. With all 3 lights on, capture an image with the gray card in the center. Import this into your software, and using the White Balance picker tool, click on the middle gray on the gray card. The acceptable gray value we are looking for is (178-184).

- 11 Finally, take a test image with the subject on the model's mark, and ensure that the image meets Amazon's criteria.



Avoid heavily retouched images and filters.

Outlined below are imaging basics for clothing photographed **off-model, laydown, or flat.**

Recommended equipment:



- Full-frame digital camera with a minimum 12 MP
- Light with stand for subject
- Pure white background
- Gray card
- Image editing software such as Adobe Photoshop, Lightroom, or Phase One

Recommended setup:

1 Set up a white shooting surface (board) on an easel.
Size: approximately 3 x 4 feet (large enough to accommodate the silhouette of your product)
Material: foam or a material that can be pinned into to secure the product

2 Set up one main (key) light to the left of your camera above (20 degrees down) your subject and set back approximately 8 feet from the background.

Point the light at a 45-degree angle to the background (angled towards the center of the background).

3 Place a center mark on your board. This is where your product will be positioned.

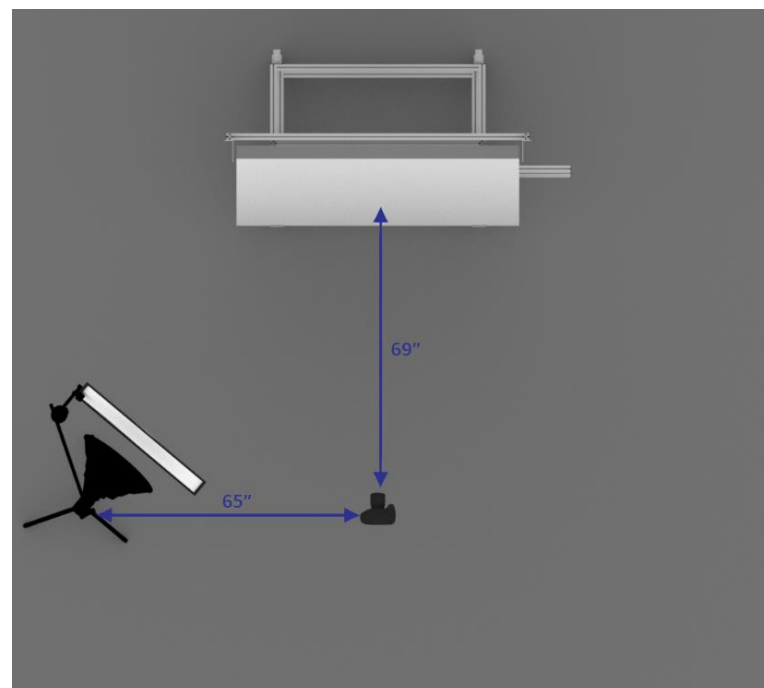

LIGHTING: OFF-MODEL (CONTINUED)

THIS GUIDE IS FOR INFORMATIONAL PURPOSES ONLY.

- 4 Now you are ready to set the lighting power levels.
- 5 Capture an image of the white background (board).
- 6 Adjust the power until the coverage of the background is even all the way across the area that will be in your image. You may need to rotate the light for evenness.
- 7 Import this image into your editing software. You are looking for pure white - color RGB value is (255,255,255). If you don't have the tools necessary to do this, ensure that the background is pure white and your camera is set to Auto.
- 8 Place your gray card in the center of your shooting board.
- 9 Capture an image with the gray card. Import this into your software, and using the White Balance picker tool, click on the middle gray on the gray card. The acceptable gray value we are looking for is (178-184).
- 10 Finally, take a test image with a product centered and pinned to the shooting board. Ensure that the image meets Amazon's criteria. You may choose to add a drop shadow in post-production.





Main Image Examples

FULL LENGTH

THIS GUIDE IS FOR INFORMATIONAL PURPOSES ONLY.

A **full-length** image is recommended for products that fall at or below the knee.

ADULT APPAREL SHOULD BE IMAGED ON-MODEL.



Dresses



Suits & Tuxedos



Sleep Sets



One-piece Garments



Sweaters, Jackets, & Outerwear (below the knee)

Robes & Nightgowns

TOP BODY

THIS GUIDE IS FOR INFORMATIONAL PURPOSES ONLY.

A **top-body** image is recommended for products below, falling below fingertips & above the knee.

ADULT APPAREL SHOULD BE IMAGED ON-MODEL.



One-piece Swimsuits & Rash Guards

Tops & Tees



Sweaters, Jackets, & Outerwear (above the knee)

WAIST DOWN

THIS GUIDE IS FOR INFORMATIONAL PURPOSES ONLY.

A **waist-down** image is recommended for products below, falling slightly above the navel & below the ribcage down to below the feet.

ADULT APPAREL SHOULD BE IMAGED ON-MODEL.



Pants & jeans



Shorts & Skirts

Leggings & Pajama Bottoms

SQUARE

THIS GUIDE IS FOR INFORMATIONAL PURPOSES ONLY.

A **square** image is recommended for underwear, swimwear, and bottoms that fall above the knee.

ADULT APPAREL SHOULD BE IMAGED ON-MODEL.



Bras & Sports Bras: Falls above the navel.



Swim Tops: Falls below the navel to differentiate from bras.

Underwear & Swim Bottoms: Falls above the navel and below the ribcage down to below the hands and above the knee.

BACK DETAIL (ATHLETIC CLOTHING)

THIS GUIDE IS FOR INFORMATIONAL PURPOSES ONLY.

If the back detail of an athletic clothing product is a key selling feature, **it is recommended to use the back detail as the Main image**, rather than the front shot.

ADULT APPAREL SHOULD BE IMAGED ON-MODEL.



Falls below the ribcage to down below the feet.

Athletic Bottoms



Falls below the fingertips and above the knee.

Athletic Tops



Falls above the navel/lower back.

Sports Bras

LAY DOWN

THIS GUIDE IS FOR INFORMATIONAL PURPOSES ONLY.

Off-model laydowns can be square or rectangular to maximize product size. The product should be shot **off-figure** ("flat"), using pins, liner, or stuffing, and using seams as a guideline to maintain symmetry from left to right. Products should be steamed and free of loose threads and fabric imperfections. **All kids, baby, accessories, and multipacks should be imaged off-figure.**



All Kids & Baby



Accessories, Including Scarves, Belts, Hats, Ties, & Cold-weather Accessories



ALL KIDS, BABY, & ACCESSORIES SHOULD BE IMAGED OFF-MODEL.



CASCADING LAY DOWN

THIS GUIDE IS FOR INFORMATIONAL PURPOSES ONLY.

ALL MULTIPACKS & SETS SHOULD BE IMAGED OFF-MODEL

The products should be laid on top of one another, cascading diagonally from left to right. The products should cascade from darkest on the top left to lightest at bottom right for lighting purposes, or with the print featured at the front. The products should be shot flat, using pins, liner, or stuffing, and using seams as a guideline to maintain symmetry from left to right. Products should be steamed and free of loose threads and fabric imperfections.

KIDS SETS, BABY SETS & MULTIPACKS





Alternate Image Examples



.MAIN (front)



.PT01 (back)



.PT02 (detail)



.FL01 (off-model)



WOMEN'S CLOTHING & SET EXAMPLES

THIS GUIDE IS FOR INFORMATIONAL PURPOSES ONLY.



.MAIN (front)



.PT01 (back)



.PT02 (detail)



.FL01 (off-model)



UNDERWEAR & SET EXAMPLES

THIS GUIDE IS FOR INFORMATIONAL PURPOSES ONLY.



.MAIN (front)



.PT01 (back)



.FL01 (off-model)



.MAIN (front)



.PT01 (front)



.PT02 (back)

SWIMWEAR EXAMPLES

THIS GUIDE IS FOR INFORMATIONAL PURPOSES ONLY.



.MAIN (front)



.PT01 (back)



.PT02 (detail)



.FL01 (off-model)



SWIMWEAR & MEN'S CLOTHING EXAMPLES

THIS GUIDE IS FOR INFORMATIONAL PURPOSES ONLY.



.MAIN (front)



.PT01 (back)



.PT02 (detail)



.FL01 (off-model)

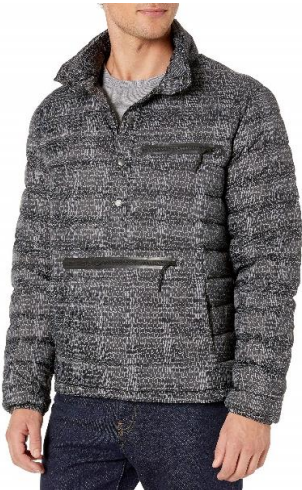



.MAIN (front)



.PT01 (back)



.FL01 (off-model)



.MAIN (off-model)



.PT01 (front)



.PT02 (back)

