



Charge, Equipotential and Field Mapper

Model No. ES-9060



Table of Contents

Equipment List	3-4
Introduction	5
Equipment Setup	6-10
Part I: Sketching the Charged Paths	6-7
Part II: Connecting the Electrodes to a Power Supply and Checking their Potential	7-8
Part III: Plotting an Equipotential	8-9
Part IV: Plotting Field Gradients	9-10
Equipotential and Field Mapping Experiments	11-15
Experiment 1: Parallel Plate Capacitor	11
Experiment 2: Point Source and Guard Ring	11
Experiment 3: Dipoles of Opposite Charge	12
Experiment 4: Dipoles of Like Charge	12
Experiment 5 :Floating Electrode	12
Experiment 6: Floating Insulator	13
Experiment 7: Line and Circular Source	13
Experiment 8: Line and Sharp Point	13
Experiment 9: Triode	14
Experiment 10: Fluid Mechanisms	14
Charge Mapping Experiments	16-21
Experiment 1: Charge Density Inside and Outside a Cylinder	18-19
Experiment 2: Charge Density on a Cone	19-20
Experiment 3: Charge Density on a Plane near a Point Source	20-21
Appendix A: Technical Support	22
Appendix B: Copyright and Warranty Information	22

Charge, Equipotential and Field Mapper

Model No. ES-9060

Equipment List

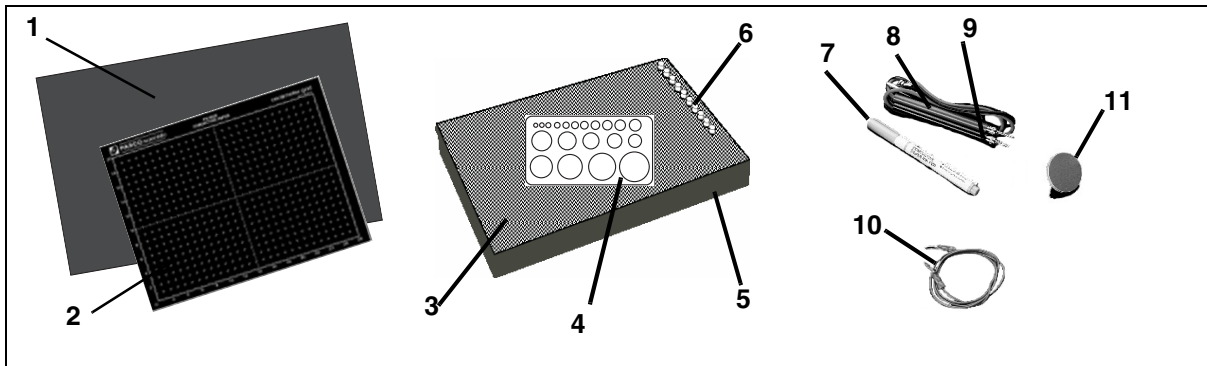

Included Equipment	Replacement Model Number*
1. Conductive paper, plain, 45 x 30 cm (no grid) (50 sheets)	646-01214
2. Conductive paper, black, 23 x 30 cm (with grid) (50 sheets)	PK-9025
3. Corkboard working surface, 32 x 48 cm (1)	648-02015
4. Circle template for drawing the conductive paths (1)	699-001
5. Large plastic tray for storing the paper and supplies (1)	648-02014
6. Push pins for attaching the paper to the board (10)	699-002
7. Conductive Ink Pen (for approximately 60 m of continuous line) (1)	PK-9031B
8. Probe, red lead (1)	517-022
9. Probe, black lead (1)	517-023
10. Wire, test lead, red, 18 awg (1)	710-032
11. Point Charge Disk (with blue charge pad) (1)	003-02018
12. Instruction sheet for PK-9025 Conductive Paper (1) (not shown)	012-04371
13. Instruction sheet for PK-9031B Conductive Ink Pen (1) (not shown)	012-04297
14. Safety sheet for PK-9031B Conductive Ink Pen (not shown)	012-04298

*Use Replacement Model Numbers to expedite replacement orders.

Additional Equipment Recommended (for Equipotential and Field Gradient Experiments)	Replacement Model No.
Voltmeter or Digital Multimeter (10 M Ω or higher)	ES-9078 or SE-9589
Electrostatics Voltage Source, DC Power Supply, or Battery	ES-9077

Additional Equipment Recommended (For Charge Mapping Experiments)	Replacement Model No.
Conductive Paper without grid, 30 cm x 46 cm (100 sheets)	PK-9026
Electrometer	ES-9078
Proof Plane	ES-9057B
Electrostatics Voltage Source or DC Power Supply	ES-9077
Faraday Ice Pail	ES-9042A

Introduction

The PASCO scientific model ES-9060 Equipotential, Charge and Field Mapper consists of two basic elements. The first is a carbon impregnated paper in the resistance range of 5 to 20 $K\Omega$ per square. This paper forms the conducting medium or space between the electrodes. The second

element is a conductive ink dispensed from a pen. The ink is produced from silver particles in a suspension liquid. As the ink dries, the silver flakes settle on top of each other forming a conductive path (or conductive ink electrodes). The resistance of the ink is between 0.03 and 0.05 Ω/cm for a 1 mm wide line.

Because the paper has a finite resistance, a current must flow through it to produce a potential difference. This current is supplied by the conductive ink electrodes, which causes a potential drop to occur across the paths. Because of the large difference between the ink's resistance and the resistance of the paper, this potential drop is less than 1% of that produced across the paper. Therefore, for all practical purposes, the potential drop across the electrodes may be considered negligible.

To plot equipotentials, charge and field gradients with the ES-9060 Equipotential, Charge and Field Mapper, you will need a voltmeter or other charge potential measuring device. It would be desirable that the potential measuring instrument have an infinite impedance. An electrometer, such as the PASCO Model ES-9054B (or ES-9078) would be optimal; however, a standard electronic voltmeter, such as PASCO's SE-9589 Handheld Digital Multimeter with a 10 $M\Omega$ (or higher) input impedance is sufficient. Since the impedance of a 10 $M\Omega$ voltmeter is at least 100 times greater than that of the paper, the greatest distortion of the field which can be produced by the voltmeter is approximately 1%.

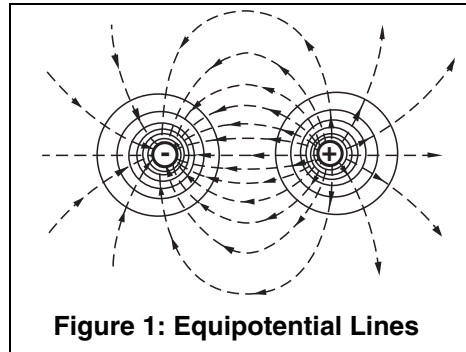

Figure 1: Equipotential Lines

Equipment Setup

Part I: Sketching the Charged Paths (Electrodes)

NOTE: The silver conductive ink reaches its maximum conductivity after 20 minutes of drying time. For optimal results, plan the time table for conducting the experiments and correlate drawing the conductive paths accordingly.

1. Plan and sketch the layout (size, shape, and relative spacing) of the charged path to be studied on a piece of paper. These paths can be any two dimensional shape, such as straight or curved lines, circles, dots, squares, etc. Since the charged paths will actually be conductive ink electrodes, they will be referred to as electrodes.
2. Draw the electrodes on the black paper (See Figure 2).

NOTE: This next steps (a-e) are the most difficult and crucial part of the experiment. Follow these steps carefully.

- a) Place the grid conductive paper printed side up, on a smooth hard surface. Do not attempt to draw the electrodes while the paper is on the corkboard.
- b) Vigorously shake the conductive ink pen (with the cap on) for 10-20 seconds to disperse any particle matter suspended in the ink.
- c) Remove the cap. On a piece of scrap paper, press lightly down on the spring-loaded tip while squeezing the pen barrel firmly. This starts the ink flowing. Slowly drawing the pen across the paper produces a solid line. Drawing speed and exerted pressure determines the path width (See Figure 3).
- d) Once a satisfactory line is produced on the scrap paper, draw the electrodes on the grid of the black conductive paper. If the line becomes thin or spotty, draw over it again. A solid line is essential for good measurements.

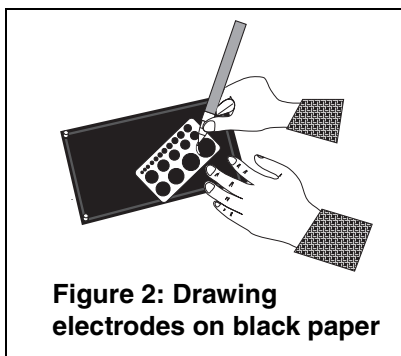

Figure 2: Drawing electrodes on black paper

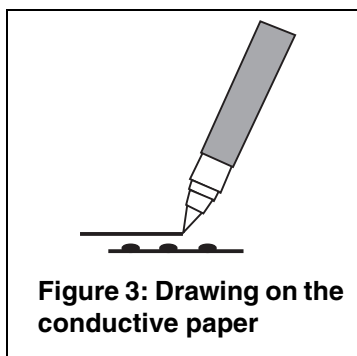

Figure 3: Drawing on the conductive paper

The line will be air dry in 3-5 minutes at room temperature. However, the medium won't reach maximum conductivity until after 20 minutes drying time.

- e) A plastic template is included with the PASCO Field Mapper for drawing circles (See Figure 4). Place the template on the conductive paper and draw the circles with the conductive ink pen. (If desired, you may first draw the circle template with a soft lead pencil and trace over the pencil line with the ink.)

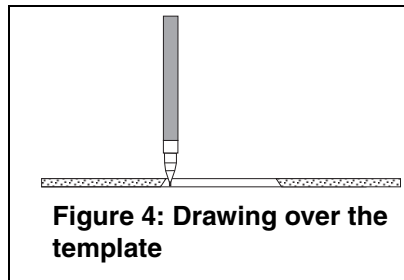

Figure 4: Drawing over the template

3. Mount the conductive paper on the corkboard using one of the metal push pins in each corner.

Part II: Connecting the Electrodes to a Power Supply and Checking their Potential

1. Using the supplied connecting wires, connect the electrodes to a battery, DC power supply, or any other potential source in the 5 to 20 VDC range (See Figure 5). The potential source should be capable of supplying 25 mA. (If possible, the potential should be equal to the full scale reading of the electronic voltmeter used in the experiment.)

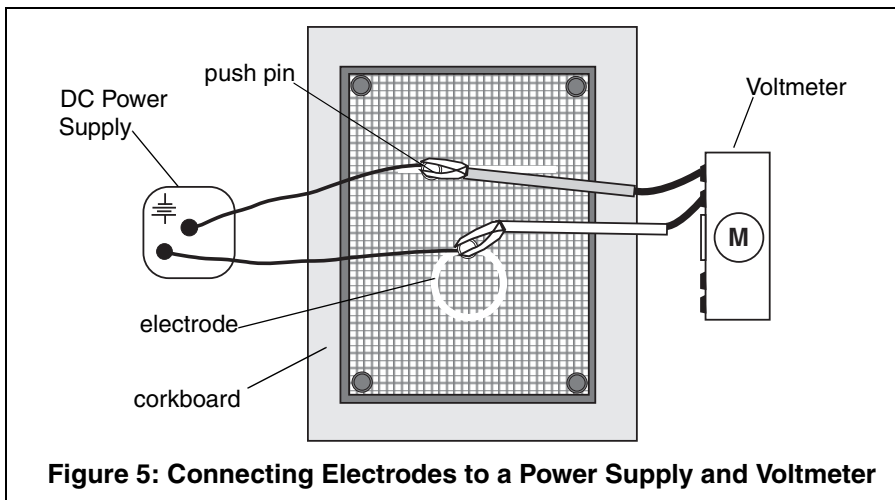

Figure 5: Connecting Electrodes to a Power Supply and Voltmeter

2. Place the terminal of a connecting wire over the electrode, then stick a metal push pin through its terminal and the electrode into the



Note: The Voltmeter used must meet the following specifications: a) be at least $10\text{ M}\Omega$ or higher and b) have a range which is equal to or higher than the potential used across the electrodes. Any commercial voltmeter, either analog or digital, is adequate. The PASCO ES-9078 Electrometer or the SE-9589 Digital Multimeter are recommended.

corkboard. Make certain the pin holds the terminal firmly to the electrode (See Figure 6).

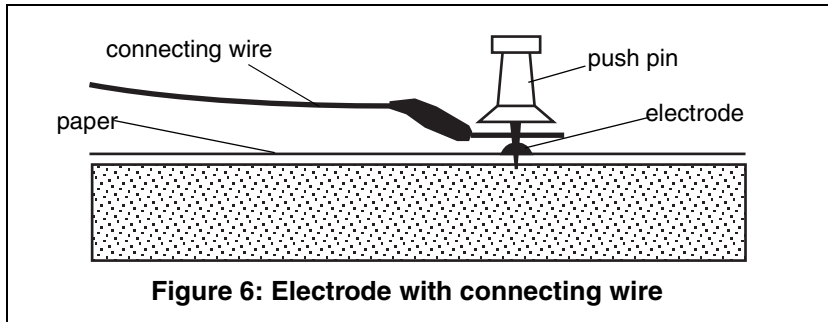

Figure 6: Electrode with connecting wire

NOTE: Check to see that the terminal which touches the electrode is clean. A dirty path may result in a bad contact.

3. Connect the other end of the wire to the battery.
4. To check the electrodes for proper conductivity, connect one voltmeter lead near the push pin on an electrode. Touch the voltmeter's second lead to other points on the same electrode. If the electrode has been properly drawn, the maximum potential between any two points on the same electrode will not exceed 1% of the potential applied between the two electrodes.

NOTE: This test can only be made if the potential source is connected across the two electrodes.

If the voltage across the same electrode is greater than 1% of the voltage applied between the two electrodes, then remove the paper from the corkboard and draw over the electrodes a second time with the conductive ink.

Part III: Plotting an Equipotential

Equipotentials are plotted by connecting one lead of the voltmeter (ground) to one of the electrode push pins. This electrode now becomes the reference. The other voltmeter lead (the probe) is used to measure the potential at any point on the paper simply by touching the probe to the paper at that point.

1. To map an equipotential, move the probe until the desired potential is indicated on the voltmeter.
2. Mark the paper at this point with a soft lead or light-colored lead pencil.

3. Continue to move the probe, but only in a direction which maintains the voltmeter at the same reading. Continue to mark these points.
4. Connect the points to produce an equipotential line.

Part IV: Plotting Field Gradients

To plot field gradients (field lines), you will place the two leads of the voltmeter on the conductive paper, side-by-side, at a set distance of separation (one centimeter is a useful separation to use). (Note: When plotting field gradients, neither lead of the voltmeter is connected to an electrode.) It is best to tape two leads of the voltmeter together for this procedure (See Figure 7). The technique is to use the voltmeter leads to find the direction from an electrode that follows the path of greatest potential difference from point to point.

NOTE: Do not attempt to make measurements by placing the leads on the grid marks on the conductive paper. Touch the voltmeter leads only on the solid black areas of the paper. It may be necessary to use a higher voltmeter sensitivity for this measurement than was used in measuring equipotentials.

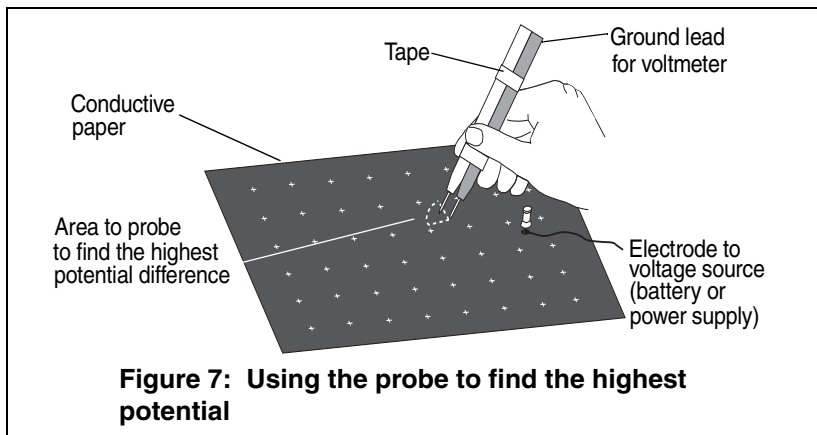

1. To plot the field lines on the conductive paper, place the voltmeter lead (connected to ground) near one of the dipoles.
2. Place the other voltmeter lead on the paper and note the voltmeter reading.
3. Now pivot the lead to several new positions while keeping the ground lead stationary (See Figure 7). Note the voltmeter readings as you touch the lead at each new spot on the paper.

- When the potential is the highest, draw an arrow on the paper from the ground lead to the other lead (See Figure 8). Then move the ground lead to the tip (head) of the arrow. Repeat the action of pivoting and touching the front lead until the potential reading in a given direction is highest.

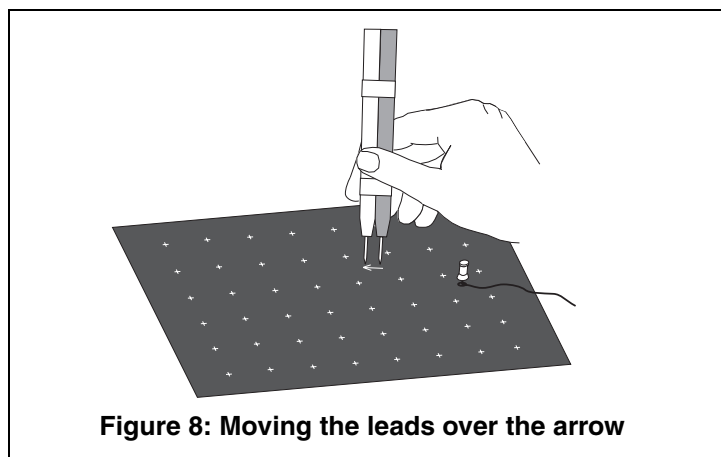

- Draw a new arrow. Repeat the action of putting the ground lead at the tip (head) of each new arrow and finding the direction in which the potential difference is highest. Eventually, the arrows drawn in this manner will form a field line.
- Return the dipole and select a new point at which to place the voltmeter's ground lead. Again, probe with the other lead until you find the direction of highest potential difference.
- Draw an arrow from the ground lead to the other lead, and repeat the process until a new field line is drawn. Continue selecting new points and drawing field lines around the original dipole (See Figure 9).

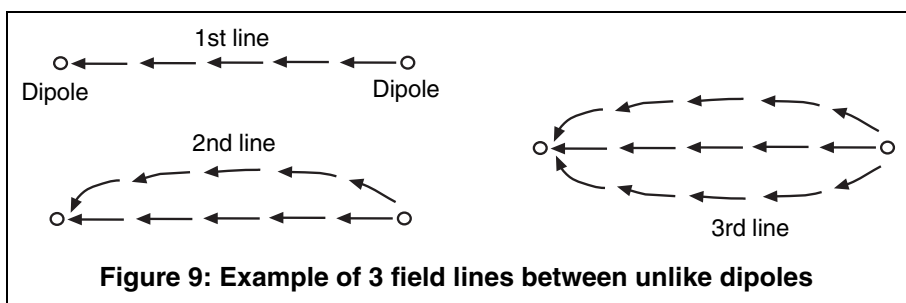

Equipotential and Field Mapping Experiments

The following are only some suggested experiments in mapping equipotentials and field gradients using the PASCO Field Mapper. The true value of the equipment lies in its complete flexibility, permitting the user to design any system of charged bodies, and then to map the equipotentials and field gradients.

NOTE: Only power supply connections are shown in the following schematics. Voltmeter connections are not shown because they vary depending on whether equipotentials or field gradients are being mapped.

Experiment 1: Parallel Plate Capacitor

Questions:

- What is the field outside the capacitor plates?
- How does the ratio of the plate length (l) versus separation (d) affect the fringing effect at the edges of the plates?
- What redesign of the plates, or perhaps the extra electrodes, could help eliminate the fringing effect?

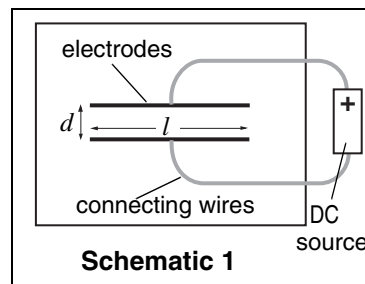

Experiment 2: Point Source and Guard Ring

Questions:

- What relation can be derived between the distance from the center of the point source and the equipotential value?
- Would this same relation hold if the system were three dimensional?
- What purpose does the large outer ring serve in this experiment?

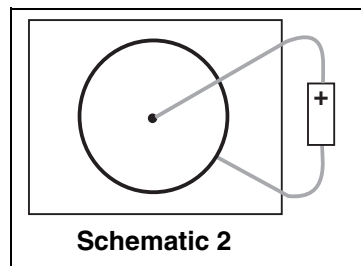

Experiment 3: Dipoles of Opposite Charge

Questions:

- What is the relation between the direction of a maximum value field gradient and equipotential line at the same point? (A geometrical relation is desired.)
- What effect does the finite size of the black paper have on the field?

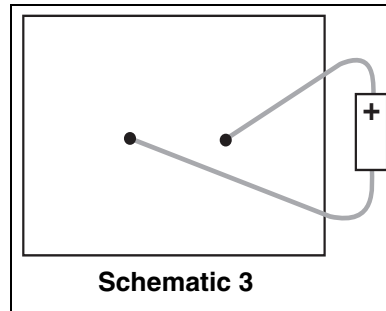
**Experiment 4: Dipoles of Like Charge**

Questions:

- How does the field of this configuration compare with dipoles of opposite charge? (See Experiment 3, “Dipoles of Opposite Charge.”)
- What distortion of the field is produced by the large electrode around the perimeter of the paper?

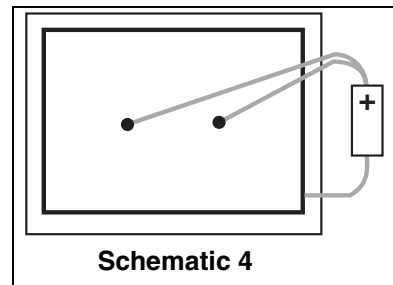
**Experiment 5: Floating Electrode**

Before drawing the circular electrode, map the equipotentials of the two straight electrodes. Draw the circular electrode and again map the equipotentials.

Questions:

- How does the circular electrode distort the field?
- What is the potential of the circular electrode? Of the area inside the electrode?
- What effect would moving the circular electrode have?

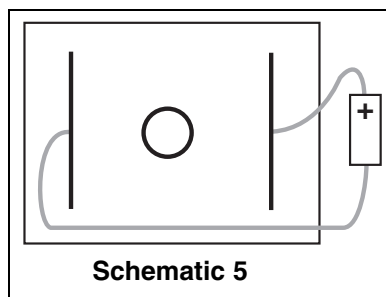

Experiment 6: Floating Insulator

Before cutting the rectangular insulator, map the equipotentials of the two straight electrodes. Cut out a rectangular section of the paper and again map the equipotentials.

Questions:

- How does the rectangular insulator distort the field?
- What effect would moving the rectangular insulator have?

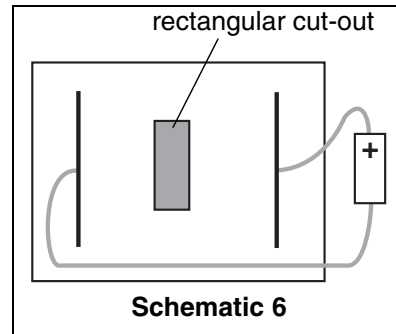

Experiment 7: Line and Circle Source

Draw only the line and point source "a." Map the equipotentials. Add circular electrode "b" and again map the equipotentials. Add circular electrode "c" and again map the equipotentials.

Questions:

- How is the spacing of the equipotentials affected by increasing the diameter of the circular electrode?

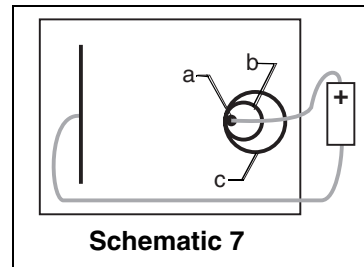

Experiment 8: Line and "Sharp" Point

Before drawing the two electrodes marked "a", map the equipotentials. Add the electrodes "a" and again map the equipotentials.

Questions:

- What effect did adding the extra electrodes have on the spacing of the equipotentials (field strength) around the point?
- Why did the field strength change, even though the radius of the point did not change?

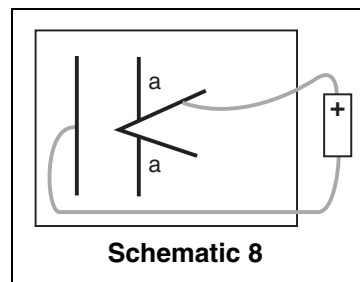

Experiment 9: Triode

Equipment required: 5 K Potentiometer

Use a 5 K Potentiometer to provide three potentials. Connect the three short electrodes with wires “a.” Do not let these wires touch the black paper except at the conductive ink electrodes.

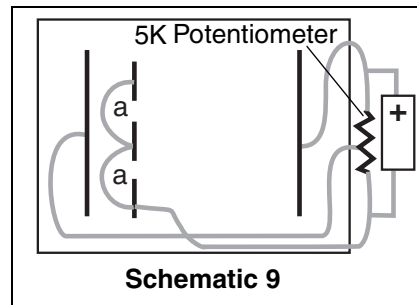

Questions:

- How is the field in the area between the short electrodes affected by the potential between the short electrodes and the closer, long electrode?
- Could this paper model of a triode act as an amplifying device? If not, why not?

Experiment 10: Fluid Mechanics Experiments

The PASCO Field Mapper can also be used to examine fluid flow. In many fluid systems, the velocity potential satisfies the Laplace equations (so does the electromagnetic potential). Consequently, there is a direct analogy between fluid flow and electric fields. In particular, the velocity potential of an incompressible fluid where the flow is both steady and not rotational satisfies the Laplace equation. A steady flow of water is a good approximation of this type of flow. Now the flow is generated by “sources” which supply the fluid and “sinks” which absorb the fluid. We are interested in “streamlines,” which can be thought of as lines traced out by a particular particle in the fluid. The streamlines begin at the sources and end at the sinks.

With the Field Mapper, we need to draw electrodes in the shape of the sources and sinks in the fluid flow to be examined. Then the electric field lines which we plot coincide with the streamlines in the fluid flow. (Remember that the electric field lines are perpendicular to the equipotential lines.) If there is some fixed obstruction in the fluid

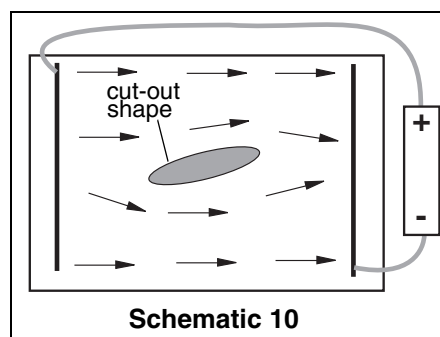

flow, we can represent it by cutting the same shape from the conductive paper. The schematic drawing shows a fluid flow which is analogous to the flow in a section of pipe (with frictionless walls). The

source is a straight line at the left, the sink is a straight line at the right. The tear-drop shaped section cut out of the middle is some obstruction. The field lines are the corresponding streamlines.

Procedure:

To use the Field Mapper to examine field flows, follow these steps.

1. Make sure that the fluid is incompressible and the flow is not rotational and steady.
2. Draw the electrodes on the conductive paper in the same shape and position as the sources and the sinks in the flow.
3. Cut out the sections of the conductive paper in the same shape and position as the obstructions in the fluid.
4. Connect a battery between the sources and the sinks. All sources should be connected to the same side of the battery. All sinks should be connected to the opposite side.
5. Plot the equipotentials and draw lines perpendicular to these. You can also pick any point and determine the direction of the maximum field gradient. This is the direction of the streamlines at that point.

Charge Mapping Experiments

The purpose of a charge mapping experiment is to investigate the way charge is distributed over a surface by measuring variations in charge density. A charged surface will be sampled with a proof plane. The proof plane will be inserted inside the Faraday Ice Pail to measure the charge. By sampling different sections of the surface, the relative charge density can be observed. For example, you may find that the amount of charge on two equal sized regions on the surface of a conductor may differ in magnitude or even in sign. This occurs for *non-uniform charge distribution*. Alternately, you may observe that everywhere on the surface the charge has the same magnitude and sign. This occurs for *uniform charge distribution*.

An important aspect of measuring charge distributions is charge conservation. The proof plane removes some charge from the surface it samples. If the proof plane is grounded after each measurement, the surface will be depleted of charge with consecutive measurements. However, by not grounding the proof plane (and by not letting it touch the ice pail), the charge on the surface is not depleted. That charge which the proof plane removed for one measurement is always returned to the surface when the next sampling is made.

The Proof Plane

As shown in Figure 10, the proof plane is an aluminum-covered conductive disk attached to an insulated handle. The conductive disk material is carbon-filled black polycarbonate (about $10^3 \Omega$) with an aluminum disk. The nonconducting neck is white polycarbonate (about $10^{14} \Omega$).

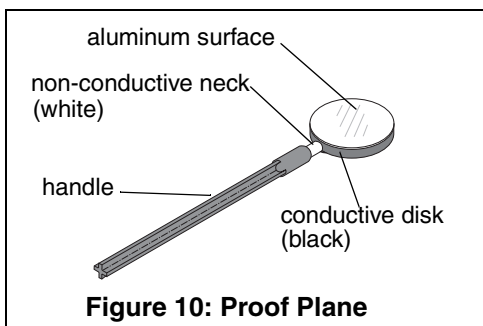
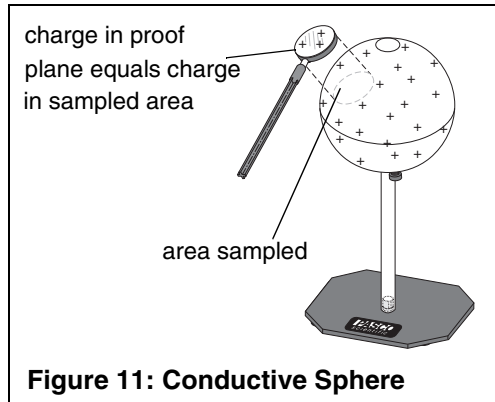

Figure 10: Proof Plane

The proof plane is used to sample the charge density on charged conductive surfaces. A Faraday Ice Pail can then be used to measure the charge density on the proof plane.

By touching the proof plane to a surface, the proof plane will acquire the same charge distribution as the section of the surface it touched (See Figure 11). By measuring the charge on the proof plane, the charge density on that part of the surface can be determined. The greater the charge on the proof plane, the greater the charge density on the surface where the proof plane made contact.



When a proof plane is touched to a conductive surface, the proof plane becomes part of the conductive surface. If the effect on the shape of the surface is significant, the sampling of the charge density will not be accurate. Therefore, always touch the proof plane to the conductor in such a way as to minimize the distortion of the shape of the surface. Figure 12 shows the recommended method for using the proof plane to sample charge on a conductive sphere.

NOTE: The proof planes can be used to test for charge polarity on conductors of any shape. However, if you want accurate readings of charge density, the conductor surface sampled has to be considerably larger than the disk of the proof plane and have a relatively large radius of curvature at the point of contact.

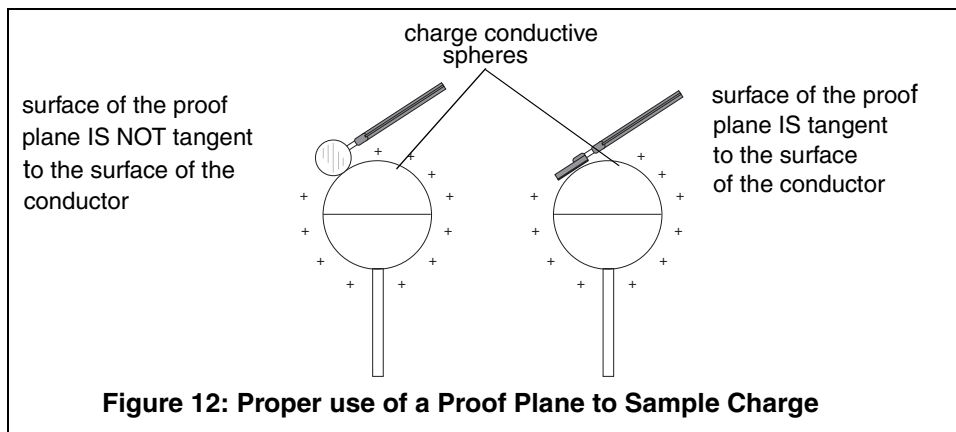

Experiment 1: Charge Density Inside and on the Surface of a Cylinder

Equipment Required:	
Charge Mapping Apparatus ES-9060)	Electrometer (ES-9078)
Proof Plane (ES-9057B)	Electrostatic Voltage Source (ES-9077)
Faraday Ice Pail (ES-9042A)	

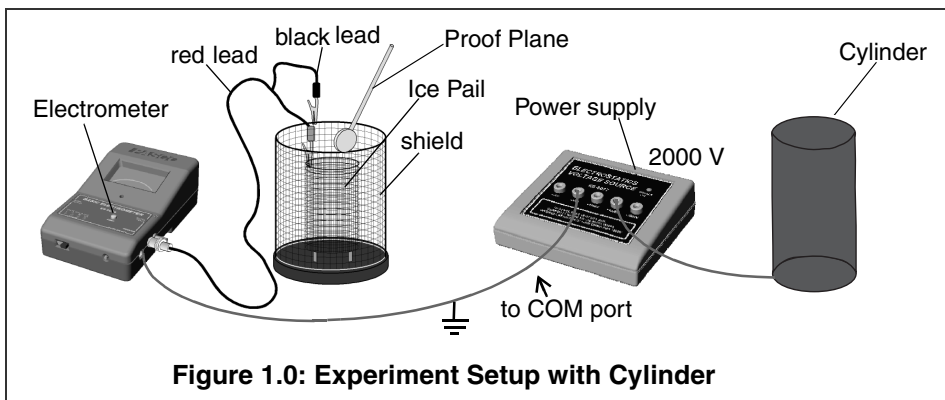

Figure 1.0: Experiment Setup with Cylinder

Procedure:

1. Connect the Electrometer, outer shield of the Faraday Ice Pail, and Electrostatics Voltage Source to a common earth ground. Follow the setup in Figure 1.0. Connect the black lead over the edge of the shield and the red lead over the edge of the ice pail. Connect the Voltage Source to the same earth ground as the shield and the Electrometer.



WARNING: To avoid the risk of shock or electrical injury, always ground your equipment. Before proceeding, follow the setup in Figure 1.0 and instructions in step 1. To ground yourself, keep one hand on the upper edge of the shield of the Faraday Ice Pail or on the earth-ground lead.

2. Zero the Electrometer to remove any residual charge.
3. Roll the large conductive paper into a cylinder 8 to 10 cm in diameter. Stand the cylinder on the corkboard, and connect the cylinder to the 2000V output of the power supply.
4. Use the Proof Plane, Electrometer, and Faraday Ice Pail to sample the charge densities at various places on the outer surface of the cylinder, inside of the cylinder, and the rim of the cylinder. Be sure to keep yourself grounded when sampling charges.

Questions:

- Why is the charge density different on the inside versus the outside of the cylinder?
- Why does the charge density change as one goes from the middle of the inside surface towards the rim?
- What is the charge density of an infinitely long cylinder?

Experiment 2: Charge Density on a Cone

Equipment Required:	
Charge Mapping Apparatus (ES-9060)	Electrometer (ES-9078)
Proof Plane (ES-9057B)	Electrostatic Voltage Source (ES-9077)
Faraday Ice Pail (ES-9042A)	

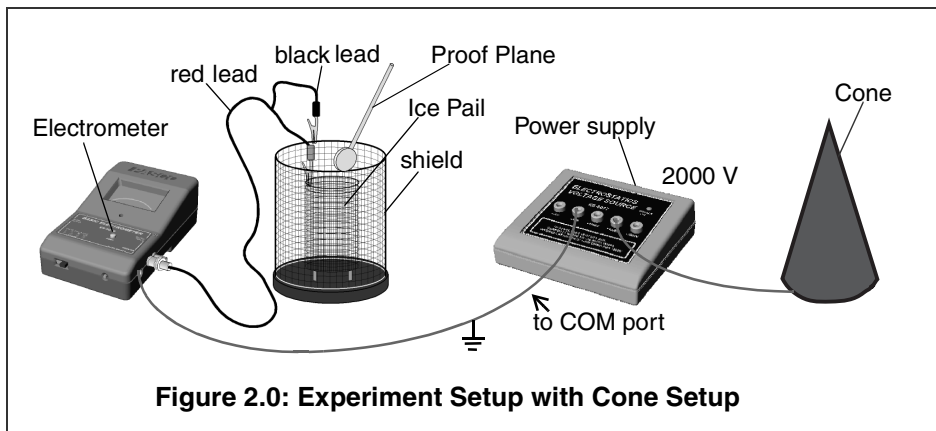
**Figure 2.0: Experiment Setup with Cone Setup****Procedure:**

1. Connect the Electrometer, outer shield of the Faraday Ice Pail, and Electrostatics Voltage Source to a common earth ground. Follow the setup in Figure 2.0. Connect the black lead over the edge of the shield and the red lead over the edge of the Ice Pail. Connect the voltage source to the same earth ground as the shield and the electrometer.



WARNING: To avoid the risk of shock or electrical injury, always ground your equipment and yourself. Before proceeding, follow the setup in Figure 2.0 and instructions in step 1. To ground yourself, keep one hand on the upper edge of the shield of the Faraday Ice Pail or on the earth-ground lead.

2. Zero the Electrometer to remove any residual charge.
3. Roll the large, conductive paper into a cone with a 10 cm diameter at the base. Make the pointed end with as low a radius as possible. Stand the cone on the corkboard, and connect the cone to the 2000V output of the power supply (See Figure 2.0).
4. Use the Proof Plane, Electrometer, and Faraday Ice Pail to sample the charge densities at various places on the cone from the 10 cm diameter base to the point. Be sure to keep yourself grounded when sampling charges.

Questions:

- a) Does there seem to be a ratio between the diameter of the cone where the proof plane touches and the charge density? (It is best to use the large end of the cone for this measurement.)
- b) Does the size of the proof plane have any effect on measurements made towards the tip of the cone? If so, why?

Experiment 3: Charge Density on a Plane near a Point Source

Equipment Required:	
Charge Mapping Apparatus ES-9060)	Electrometer (ES-9078)
Proof Plane (ES-9057B)	Electrostatic Voltage Source (ES-9077)
Faraday Ice Pail (ES-9042A)	

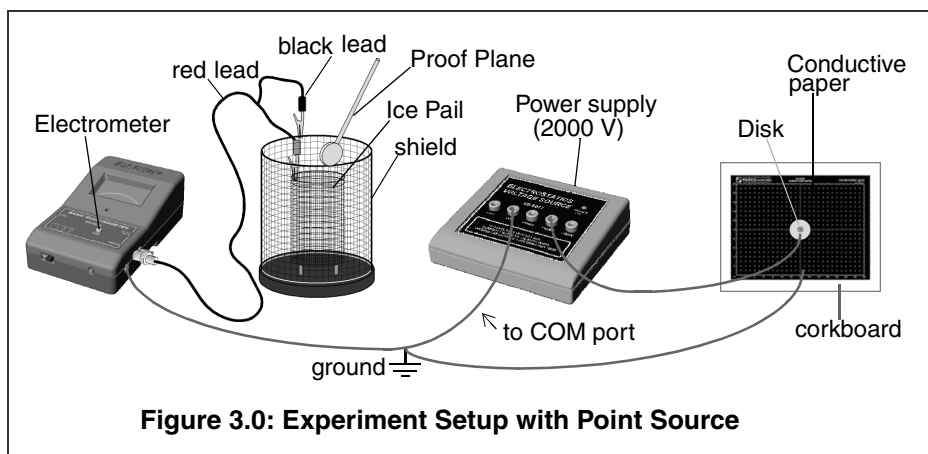

Procedure:

1. Connect the Electrometer, outer shield of the Faraday Ice Pail, and Electrostatics Voltage Source to a common earth ground. Follow the setup in Figure 3.0. Connect the black lead over the edge of the shield and the red lead over the edge of the ice pail. Connect the Voltage Source to the same earth ground as the shield and the Electrometer.



WARNING: To avoid the risk of shock or electrical injury, always ground your equipment. Before proceeding, follow the setup in Figure 3.0 and instructions in step 1. To ground yourself, keep one hand on the upper edge of the shield of the Faraday Ice Pail or on the earth-ground lead.

2. Zero the Electrometer to remove any residual charge.
3. Place a sheet of 30 x 46 cm conductive, black paper on the corkboard. Connect this paper to ground.
4. Place the “point charge disk” in the center of the paper with the plastic insulator between the paper and disk. Connect the disk to a 2000V DC or higher power supply (See Figure 3.0).
5. Ground yourself by placing one hand or finger on the shield of the ice pail or the ground connector.
6. Use the Proof Plane to sample the charge density about every 3 centimeters on a line from the disk to one of the corners of the paper.

Remember, any wires used to connect the paper shape to the power supply must also affect the charge distribution. Therefore, exercise extreme care in the placement of the wires.

Questions:

- a) Does there seem to be a ratio between the distance of the proof plane from the “point charge disk” and the charge density? What might this relationship be?
- b) Would the charge density be different if the conductive paper sheet were infinite in size?

Appendix A: Technical Support

For assistance with the ES-9060 Charge, Equipotential and Field Mapper or any other PASCO products, contact PASCO as follows:

Address: PASCO scientific

10101 Foothills Blvd.

Roseville, CA 95747-7100

Phone: (916) 786-3800 or 1-800-772-8700

FAX: (916) 786-3292

Web: www.pasco.com

Email: techsupp@pasco.com

Appendix B: Copyright and Warranty Information

Copyright Notice

The PASCO scientific 012-08455A *Charge, Equipotential, and Field Mapper Manual* is copyrighted and all rights reserved. However, permission is granted to non-profit educational institutions for reproduction of any part of the 012-08455A *Charge, Equipotential and Field Mapper Manual*, providing the reproductions are used only for their laboratories and are not sold for profit. Reproduction under any other circumstances, without the written consent of PASCO scientific, is prohibited.

Limited Warranty

PASCO scientific warrants the product to be free from defects in materials and workmanship for a period of one year from the date of shipment to the customer. PASCO will repair or replace, at its option, any part of the product which is deemed to be defective in material or workmanship. The warranty does not cover damage to the product caused by abuse or improper use. Determination of whether a product failure is the result of a manufacturing defect or improper use by the customer shall be made solely by PASCO scientific. Responsibility for the return of equipment for warranty repair belongs to the customer. Equipment must be properly packed to prevent damage and shipped postage or freight prepaid. (Damage caused by improper packing of the equipment for return shipment will not be covered by the warranty.) Shipping costs for returning the equipment after repair will be paid by PASCO scientific.

