

## User Profile Questionnaire

S1001-BDHO-FO-025

Dealer Name: \_\_\_\_\_

Date Of Sale

### Model Purchased

Main User Yes  No

- |                                    |                                     |                                       |   |                                      |
|------------------------------------|-------------------------------------|---------------------------------------|---|--------------------------------------|
| <input type="checkbox"/> Activa 5G | <input type="checkbox"/> Activa 125 | <input type="checkbox"/> Dream Yuga   | <input type="checkbox"/> CB Shine SP    | <input type="checkbox"/> CBR 250R    |
| <input type="checkbox"/> Dio       | <input type="checkbox"/> GRAZIA     | <input type="checkbox"/> Dream Neo    | <input type="checkbox"/> CB Unicorn     | <input type="checkbox"/> CBR 650F    |
| <input type="checkbox"/> Aviator   | <input type="checkbox"/> NAVI       | <input type="checkbox"/> CD 110 Dream | <input type="checkbox"/> CB Unicorn 160 | <input type="checkbox"/> Africa Twin |
| <input type="checkbox"/> Activa I  |                                     | <input type="checkbox"/> Livo         | <input type="checkbox"/> CB Hornet 160R |                                      |
| <input type="checkbox"/> CLIQ      |                                     | <input type="checkbox"/> CB Shine     | <input type="checkbox"/> X BLADE        |                                      |

Name: \_\_\_\_\_ Date of Birth: \_\_\_\_\_ Gender  Male  Female Marital Status  Married  Unmarried

City: \_\_\_\_\_ Phone No.: \_\_\_\_\_ Have Kids  Yes  No If Yes, How Many

01. Occupation

- 1 Student  2 Comp Employee  3 Own Business  4 Agriculture / Fishery  5 Housewife  6 Other

02. What is your Monthly Family Income (of combined household including yourself)?

- 1 ≤ 10,000  2 10,001 to 20,000  3 20,001 to 30,000  4 30,001 to 50,000  5 50,001 to 1,00,000  6 >1,00,000

03. Please give details of the model you are presently using for yourself ?(If you have any)

Maker \_\_\_\_\_ Model \_\_\_\_\_ Yr of Purchase \_\_\_\_\_

Continue....

04. What are the major reasons for buying this model now?

- 1 Able to afford a 2 wheeler now  4 Current 2 wheeler is not convenient  
 2 People needing 2 wheeler in the family increased  5 Current 4 wheeler is not suitable for daily usage  
 3 Current 2 wheeler Has Become Old  6 Other →

05. Is there someone other than you, who will ride this model?

- Yes (If Yes) →  Male  Female  
 No

06. Before buying this model, did you make comparison with any other models? **Mention cc**

- No comparison made  
 Yes, Please mention model (s) →  Model 1  Model 2  Model 3  Model 4

07. What are the reasons for your buying this model?

- 1 Style  2 Brand  3 Mileage  4 Reasonable Price  5 Advance Technology  
 6 Power & Pick up  7 After Sales Service  8 Low Maintenance  9 Resale Value  10 Riding Comfort  
 11 Other

## WELCOME

The vehicle presents you a challenge to master the machine, a challenge to adventure. You ride through the wind, linked to the road by a vehicle that responds to your commands as no other does. Unlike an automobile, there is no metal cage around you. Like an air plane, a pre-ride inspection and regular maintenance are essential to your safety. Your reward is freedom.

To meet the challenges safely, and to enjoy the adventure fully, you should become thoroughly familiar with this owner's manual BEFORE YOU RIDE THE VEHICLE.

As you read this manual, you will find information that is preceded by a **NOTICE** symbol. This information is intended to help you avoid damage to your vehicle, other property, or the environment.

When service is required, remember that your Honda dealer knows your vehicle. If you have the required mechanical "know-how" and tools, your dealer can supply you an official Honda shop manual on paid basis to help you perform many maintenance and repair tasks.

Accessories shown in the illustration are not part of the standard equipment.

For any query or assistance, please call Customer Care No.:

**1800 103 3434 (Toll free)**

Pleasant riding, and thank you for choosing a Honda!

- The specifications may vary with each locale.

© Honda Motor Co., Ltd. 2018

## **IMPORTANT INFORMATION**

- **RIDER AND PILLION RIDER**

This vehicle is designed to carry the rider and one pillion rider. Never exceed the maximum weight capacity.

- **ON-ROAD USE**

This vehicle is designed to be used only on the road.

- **READ THIS OWNER'S MANUAL CAREFULLY**

Pay special attention to the safety messages that appear throughout the manual.

This manual should be considered as a permanent part of the vehicle and should remain with the vehicle when resold.

**All information in this publication is based on the latest production information available at the time of approval for printing. Honda Motor Co., Ltd. reserves the right to make changes at any time without notice and without incurring any obligation.**

**No part of this publication may be reproduced without written permission.**

## TABLE OF CONTENTS

	Page		Page
<b>CATALYTIC CONVERTER</b> -----	<b>1</b>	Fuel-----	24
<b>A FEW WORDS ABOUT SAFETY</b> -----	<b>2</b>	Evaporative Emission Control System --	26
<b>VEHICLE SAFETY</b> -----	<b>3</b>	Engine Oil -----	27
Important Safety Information-----	3	Tyres-----	28
Protective Apparel -----	4	<b>ESSENTIAL INDIVIDUAL</b>	
Load Limits and Guidelines-----	5	<b>COMPONENTS</b> -----	<b>31</b>
Anti-theft Tips-----	7	Ignition Switch -----	31
<b>PARTS LOCATION</b> -----	<b>8</b>	Right Handlebar Controls-----	32
Serial Numbers-----	10	Left Handlebar Controls -----	33
Keys -----	10	<b>FEATURES</b> -----	<b>34</b>
Instrument and Indicators -----	11	<b>(Not required for operation)</b>	
<b>MAJOR COMPONENTS</b> -----	<b>18</b>	Steering Lock -----	34
<b>(Important Information to operate this</b>		Seat -----	34
<b>vehicle)</b>		Helmet Holder-----	35
Suspension -----	18	Document & Storage Compartment ----	36
Brakes -----	19	Right Under Cowl -----	36
Clutch-----	21	Headlight Aim Vertical Adjustment ----	37
Coolant -----	22		

## TABLE OF CONTENTS

	Page		Page
<b>OPERATION -----</b>	<b>38</b>	Coolant -----	54
Pre-ride Inspection -----	38	Air Cleaner -----	54
Starting the Engine -----	38	Drive Chain-----	56
Running-in -----	40	Front and Rear Suspension Inspection --	60
Riding-----	40	Side Stand -----	60
Braking -----	41	Wheel Removal-----	61
Parking -----	43	Brake Pad Wear -----	65
<b>MAINTENANCE -----</b>	<b>44</b>	Battery -----	66
The Importance of Maintenance -----	44	Fuse Replacement -----	68
Maintenance Safety -----	44	Brake Light Switch Adjustment -----	70
Safety Precautions -----	45	Bulb Replacement-----	70
Maintenance Schedule -----	46	<b>CLEANING -----</b>	<b>73</b>
Tool Kit & First Aid Kit -----	49	<b>STORAGE GUIDE -----</b>	<b>74</b>
Color Code -----	49	Storage -----	74
Engine Oil -----	50	Removal from Storage -----	75
Crankcase Breather -----	53	<b>SPECIFICATIONS -----</b>	<b>76</b>
Throttle Operation -----	53	<b>WARRANTY POLICY -----</b>	<b>79</b>

## CATALYTIC CONVERTER

This Vehicle is equipped with a catalytic converter.

The catalytic converter contains precious metals that serve as catalysts. Promoting chemical reactions to convert the exhaust gasses without affecting the metals.

The catalytic converter acts on HC, CO, and NOx. A replacement unit must be an original Honda part or its equivalent.

The catalytic converter must operate at a high temperature for the chemical reactions to take place. It can set on fire any combustible materials that come near it. Mark your vehicle away from high grasses, dry leaves, or other flammables.

A defective catalytic converter contributes to air pollution, and can impair your engine's performance. Follow these guidelines to protect your motorcycle's catalytic converter.

- Always use unleaded petrol. Even a small amount of leaded petrol can contaminate the catalyst metals, making the catalytic converter ineffective.
- Keep the engine tuned-up.
- Have your vehicle diagnosed and replaced if it is misfiring, backfiring stalling or otherwise not running properly.

## A FEW WORDS ABOUT SAFETY

Your safety, and the safety of others, is very important. Operating this vehicle safely is an important responsibility.

To help you make informed decisions about safety, we have provided operating procedures and other information on labels in this manual. This information alerts you to potential hazards that could hurt you or others.

Of course, it is not practical or possible to warn you about all hazards associated with operating or maintaining a vehicle. You must use your own good judgment.

You will find important safety information in a variety of forms, including :

- **Safety labels** - on the vehicle.
- **Safety messages** - preceded by a safety alert symbol  and one of three signal words: **DANGER**, **WARNING**, or **CAUTION**.

These signal words mean:

 **DANGER** You **WILL** be **KILLED** or **SERIOUSLY HURT** if you don't follow instructions.

 **WARNING** You **CAN** be **KILLED** or **SERIOUSLY HURT** if you don't follow instructions.

 **CAUTION** You **CAN** be **HURT** if you don't follow instructions.

- **Safety Heading** - such as Important Safety Reminders or Important Safety Precautions.
- **Safety Section** – such as vehicle Safety.
- **Instructions** – how to use this vehicle correctly and safely.

This entire manual is filled with important safety information—please read it carefully.



## **VEHICLE SAFETY**

### **IMPORTANT SAFETY INFORMATION**

Your vehicle can provide many years of service and pleasure if you take responsibility for your own safety and understand the challenges that you can meet on the road.

There is much that you can do to protect yourself when you ride. You'll find many helpful recommendations throughout this manual. Following a few that we consider most important.

#### **Always Wear a Helmet**

It's a proven fact: helmets significantly reduce the number and severity of head injuries. So always wear an approved helmet and make sure your pillion rider does the same. We also recommend that you wear eye protection, sturdy boots, gloves, and other protective gear (page 4 ).

#### **Make Yourself Easy to be Visible**

Some riders do not see vehicles because they are not looking for them. To make yourself more visible, wear bright reflective clothing, position yourself so other riders can see you, signal before turning or changing lanes, and use your horn when it will help others notice you.

#### **Ride Within Your Limits**

Pushing the limits is another major cause of vehicle accidents. Never ride beyond your personal abilities or faster than conditions warrant. Remember that alcohol, drugs, fatigue and inattention can significantly reduce your ability to make good judgements and ride safely.

#### **Keep Your Vehicle in Safe Condition**

For safe riding, it's important to inspect your vehicle before every ride and perform all recommended maintenance. Never exceed load limits, and only use accessories that have been approved by Honda for this vehicle. See page 6 for more details.

## Don't Drink and Ride

Alcohol and riding don't mix. Even one drink can reduce your ability to respond to changing conditions, and your reaction time gets worse with every additional drink. So don't drink and ride, and don't let your friends drink and ride either.

## PROTECTIVE APPAREL

For your safety, we strongly recommend that you always wear an approved helmet, eye protection, boots, gloves, long pants, and a long-sleeved shirt or jacket whenever you ride. Although complete protection is not possible, wearing proper gear can reduce the chance of injury when you ride. Following are suggestions to help you choose proper gear.

### **WARNING**

Not wearing a helmet increases the chance of serious injury or death in a crash.

Be sure you and your pillion rider always wear a helmet, eye protection and other protective apparel when you ride.

## Helmets and Eye Protection

Your helmet is your most important piece of riding gear because it offers the best protection against head injuries. A helmet should fit your head comfortably and securely. A bright-coloured helmet can make you more noticeable in traffic, as can reflective strips.

An open-face helmet offers some protection, but a full-face helmet offers more. Always wear a face shield or goggles to protect your eyes and help your vision.

## Additional Riding Gear

In addition to a helmet and eye protection, we also recommend:

- Sturdy boots with non-slip soles to help protect your feet and ankles.
- Leather gloves to keep your hands warm and help prevent blisters, cuts, burns and bruises.
- A vehicle riding suit or jacket for comfort as well as protection. Bright coloured and reflective clothing can help make you more noticeable in traffic. Be sure to avoid loose clothes that could get caught on any part of your vehicle.

## LOAD LIMITS AND GUIDELINES

Your vehicle has been designed to carry you one pillion rider. When you carry a pillion rider, you may feel some difference during acceleration and braking. But so long as you keep your vehicle well-maintained, with good tyres and brakes, you can safely carry loads within the given limits and guidelines.

However, exceeding the weight limit or carrying an unbalanced load can seriously affect your vehicle's handling, braking and stability. Non-Honda accessories, improper modifications, and poor maintenance can also reduce your safety margin.

The following pages give more specific information on loading, accessories and modifications.

### Loading

How much weight you put on your vehicle, and how you load it, are important to your safety. Anytime you ride with a pillion rider or cargo you should be aware of the following information.

## WARNING

Overloading or improper loading can cause a crash and you can be seriously hurt or killed.

Follow all load limits and other loading guidelines in this manual.

### Load Limits

Following are the load limits for your vehicle:

#### Maximum weight capacity:

**180 kg (397 lbs)**

Includes the weight of the rider, pillion rider, all cargo and all accessories

### LOADING GUIDELINES

Your vehicle is primarily intended for transporting you and a pillion rider. You may wish to secure a jacket or other small items to the seat when you are not riding with a pillion rider. If you wish to carry more cargo, check with your Honda dealer for advice, and be sure to read the information regarding accessories on page 6.

Improperly loading your vehicle can affect its stability and handling. Even if your vehicle is properly loaded, you should ride at reduced speeds whenever carrying cargo. Follow these guidelines whenever you carry a pillion rider or cargo:

- Check that both tyres are properly inflated.
- If you change your normal load, you may need to adjust the rear suspension (page 18)
- To prevent loose items from creating a hazard, make sure that all cargo is securely tied down before you ride away.
- Place cargo weight as close to the center of the vehicle as possible.
- Balance cargo weight evenly on both sides.
- Do not attach large or heavy items (such as a sleeping bag or tent) to the handlebars, forks or fender.

### **Accessories and Modifications**

Modifying your vehicle or using non-Honda accessories can make your vehicle unsafe. Before you consider making any modifications or adding an accessory, be sure to read the following information.

## **WARNING**

Improper accessories or modifications can cause a crash in which you can be seriously hurt or killed.

Follow all instructions in this owner's manual regarding accessories and modifications.

### **Accessories**

We strongly recommend that you use only Honda Genuine Accessories that have been specifically designed and tested for your vehicle. Because Honda cannot test all other accessories, you must be personally responsible for proper selection, installation and use of non-Honda accessories. Check with your Honda dealer for assistance and always follow these guidelines:

- Make sure the accessory does not obscure any lights, reduce ground clearance and banking angle, limit suspension travel or steering travel, alter your riding position or interfere with operating any controls.

- Be sure not to use any non-genuine electrical equipment or equipment having capacity exceeding vehicle's electrical system capacity (page 77). A blown fuse can cause a loss of lights or engine power.
- Do not pull a trailer or sidecar with your vehicle. This vehicle is not designed for these attachments, and their use can seriously impair your vehicle's handling.

## MODIFICATIONS

We strongly advise you not to remove any original equipment or modify your vehicle in any way that would change its design or operation. Such changes could seriously impair your vehicle's handling, stability and braking, making it unsafe to ride.

Removing or modifying your lights, mufflers, emission control system or other equipment can also make your vehicle illegal.

## ANTI-THEFT TIPS

1. Always lock the steering
2. Never leave the key in the ignition switch. This sounds simple but people do forget.
3. Be sure the registration information for your vehicle is accurate and current.
4. Put your vehicle in a locked garage whenever possible.
5. Use an additional anti-theft device of good quality.
6. Put your name, address, and phone number in this Owner's Manual and keep it on your vehicles at all times.

Many times stolen vehicles are identified by information in the Owner's Manual.

**NAME:** \_\_\_\_\_

**ADDRESS:** \_\_\_\_\_

**PHONE NO:** \_\_\_\_\_

## PARTS LOCATION

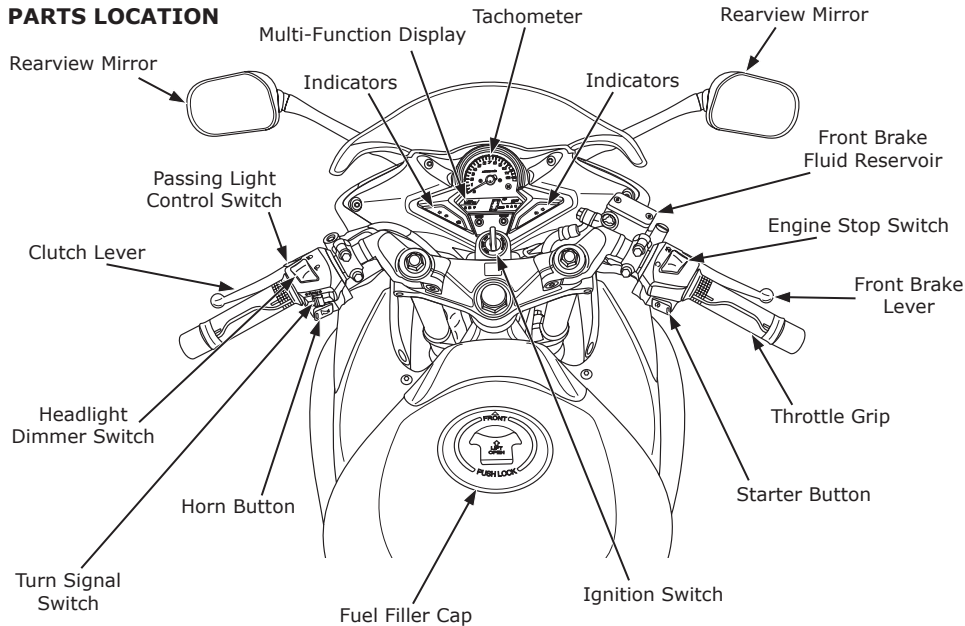

## Right Side View

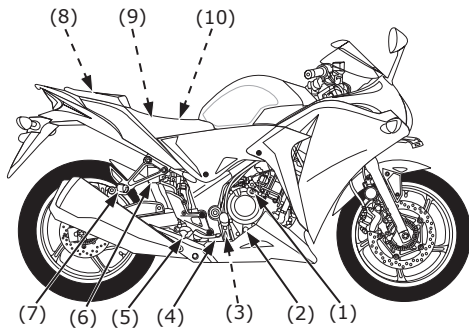

## Left Side View

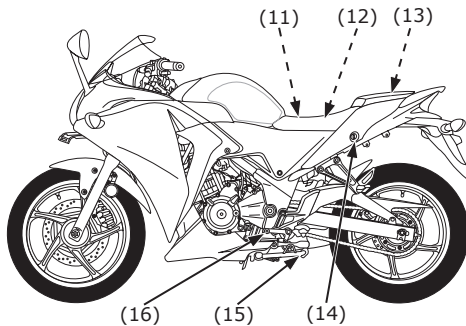

(1) Oil Filler Cap	(9) ABS Motor Fuse (CBR250RAJ)
(2) Engine Oil Inspection Window	(10) Battery
(3) Coolant Reserve Tank	(11) Main Fuse
(4) Rear Brake Pedal	(12) Fuse Box
(5) Footpeg	(13) Helmet Holder
(6) Rear Brake Fluid Reservoir	(14) Seat Lock
(7) Pillion Rider Footpeg	(15) Side Stand
(8) Storage Compartment	(16) Gearshift Pedal

## SERIAL NUMBERS

The frame and engine serial numbers are required when registering your vehicle. They may also be required by your Honda dealer when ordering replacement parts.

The "Frame Number" (1) is stamped on the right side of the steering head. The "Engine Number" (2) is stamped on the left side of the crankcase.

Record the numbers here for your reference.

FRAME NO. \_\_\_\_\_

ENGINE NO. \_\_\_\_\_

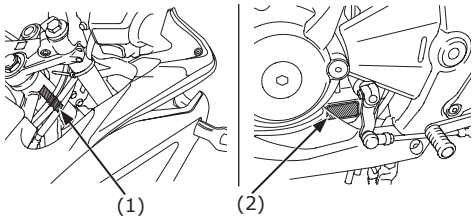

(1) Frame Number

(2) Engine Number

## KEYS

This vehicle has two "Ignition Keys" (1) and a "Key Number Plate" (2).

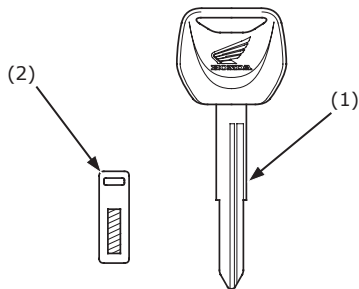

(1) Ignition Key

(2) Key Number Plate

You will need the key number if you ever have to replace a key. Store the plate in a safe place.

To reproduce keys, bring all keys, key number plate and vehicle to your Honda dealer.



## INSTRUMENT AND INDICATORS

The indicators are contained in the instrument panel. Their functions are described in the tables on the following pages.

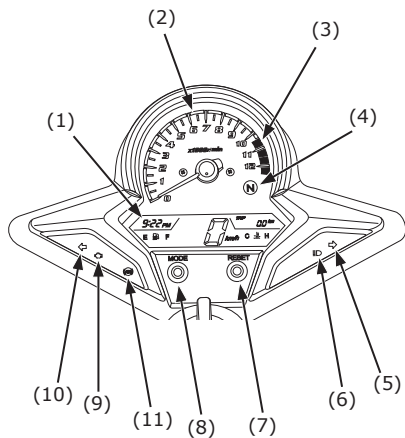

- (1) Multi- Function Display
- (2) Tachometer
- (3) Tachometer Red Zone
- (4) Neutral Indicator
- (5) Right Turn Signal Indicator
- (6) High Beam Indicator
- (7) Reset Button
- (8) Mode Button
- (9) Pgm-Fi Malfunction Indicator Lamp (MIL)
- (10) Left Turn Signal Indicator
- (11) Anti-Lock Brake System (ABS) Indicator (CBR250RAJ)

<b>(Ref.No.) Description</b>	<b>Function</b>
1. Multi-Function Display	The display includes the following functions; This display shows the initial display (page 14). Speedometer Shows riding speed (page 15). Odometer Shows accumulated mileage (page 15). Tripmeter Shows mileage per trip (page 15). Coolant Temperature Gauge Shows coolant temperature (page 15). Fuel Gauge Shows approximate fuel supply available (page 16). Digital Clock Shows hour and minute (page 17).
2. Tachometer	Shows engine revolutions per minute. The tachometer needle will swing to the maximum scale on the dial once when the ignition switch is turned ON.
3. Tachometer Red Zone	Never allow the tachometer needle to enter the red zone, even after the engine has been broken in. <b>NOTICE</b> Running the engine beyond recommended maximum engine speed (the beginning of the tachometer red zone) can damage the engine.
4. Neutral Indicator (green)	Lights when the transmission is in neutral.

<b>(Ref.No.) Description</b>	<b>Function</b>
5. Right Turn Signal Indicator (green)	Flashes when the right turn signal operates.
6. High Beam Indicator (blue)	Lights when the headlight is on high beam.
7. RESET Button	This button is used to reset the tripmeter (page 15) or to set the digital clock (page 17).
8. MODE Button	This button is used to select the odometer and tripmeter (page 15) or to set the digital clock (page 17).
9. PGM-FI Malfunction Indicator Lamp (MIL) (amber)	Lights when there is any abnormality in the PGM-FI (Programmed Fuel Injection) system. Should also light for a few seconds and then go off when the ignition switch is turned ON. If it comes on at any other time, reduce speed and take the vehicle to your Honda dealer as soon as possible.
10. Left Turn Signal Indicator (green)	Flashes when the left turn signal operates.
11. Anti-lock Brake System (ABS) Indicator (CBR250RAJ) (amber)	This indicator normally comes on when the ignition switch is turned ON, and goes off after you ride the vehicle at speed above 10 km/h (6 mph). If there is a problem with the Anti-lock Brake System, this indicator flashes and remains on (page 11).

## Initial Display

When the ignition switch is turned ON, the "Multi-function Display" (1) will temporarily show all the modes and digital segments. Thereafter, the "Speedometer" (2) starts a countdown to 0 km/h so that you can make sure the liquid crystal display is functioning properly.

"Digital Clock" (3) will reset if the battery is disconnected.

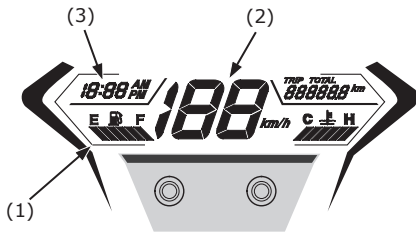

- (1) Multi-function Display
- (2) Speedometer
- (3) Digital Clock

## Multi-function Display

"Multi-function Display" (1) includes the following functions:

- Speedometer
- Odometer/Tripmeter
- Coolant Temperature Gauge
- Fuel Gauge
- Digital Clock

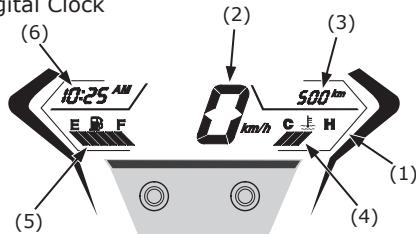

- (1) Multi-function Display
- (2) Speedometer
- (3) Odometer/Tripmeter
- (4) Coolant Temperature Gauge
- (5) Fuel Gauge
- (6) Digital Clock

## Speedometer

"Speedometer" (1) shows riding speed.

## Odometer/Tripmeter

The "Odometer" (2) shows accumulated mileage.

The "Tripmeter" (3) shows mileage per trip.

Push the "MODE Button" (4) to select the odometer and tripmeter.

To reset the tripmeter, push and hold the "RESET Button" (5) for more than 2 seconds when the display is in the tripmeter.

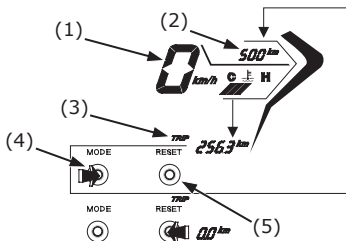

- (1) Speedometer
- (2) Odometer
- (3) Tripmeter
- (4) MODE Button
- (5) RESET Button

## Coolant Temperature Gauge

The "Coolant Temperature Gauge" (1) shows coolant temperature.

The normal operating temperature range is within the section between the "Segment C" (2) and "Segment H" (3).

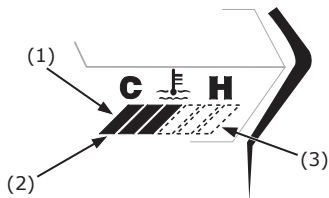

- (1) Coolant Temperature Gauge
- (2) Segment C
- (3) Segment H

## Overheating Message:

When the coolant is over specified temperature, the segment H flashes.

If this occurs, stop the engine and check the reserve tank coolant level.

Read page 22 and do not ride the vehicle until the problem has been corrected.

**NOTICE**

*Exceeding maximum running temperature may cause serious engine damage.*



**Coolant Temperature Gauge Failure Indication:**

If the cooling system has an error, the coolant temperature gauge will flash or will turn off.

If this occurs, visit your nearest Honda dealer as soon as possible.

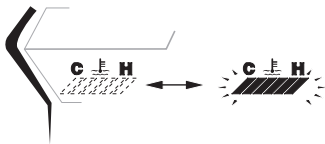

**Fuel Gauge**

The "Fuel Gauge" (1) liquid crystal display shows the approximate available fuel in a graduated display. When all segments up to "Segment F" (2) are on, the fuel tank is full.

The fuel tank capacity is:

13.0 L (3.43 US gal , 2.86 Imp gal)

When there is only one "Segment E" (3) left, fuel will be low and you should refuel as soon as possible.

The amount of fuel left in the tank with the vehicle set upright is approximately:

3.5 L (0.92 US gal , 0.77 Imp gal)

This segment flashes when the fuel decreases further.

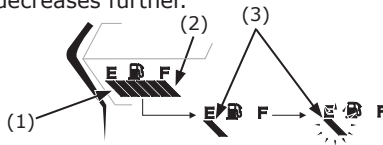

- (1) Fuel Gauge
- (2) Segment F
- (3) Segment E

### Fuel Gauge Failure Indication:

If the fuel system has an error, the fuel gauge will flash.

If this occurs, visit your nearest Honda dealer as soon as possible.

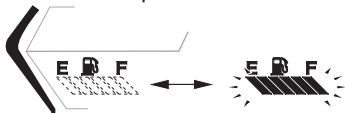

### Digital clock

Shows hour and minute. To set the "Digital Clock" (1), proceed as follows:

1. Turn the ignition switch ON.
2. Push and hold both the "MODE Button" (2) and "RESET Button" (3) for more than 2 seconds. The clock will be set in the adjust mode with the hour display flashing.

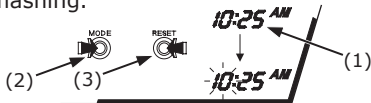

- (1) Digital Clock
- (2) MODE Button
- (3) RESET Button

3. To set the hour, push the RESET button until the desired hour and AM/PM are displayed.

- The time is advanced by one hour, each time the button is pushed.
- The time advances fast when the button is pushed and held.

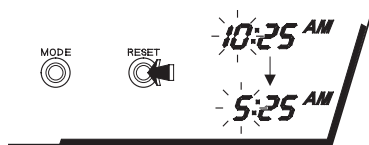

4. Push the MODE button. The minute display will start flashing.

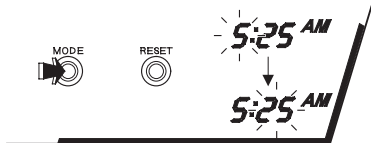

5. To set the minute, push the RESET button until the desired minute. The minute display will return to "00" when "60" is reached without affecting the hour display.
- The time advances by one minute, each time the button is pushed.
  - The time advances fast when the button is pushed and held.

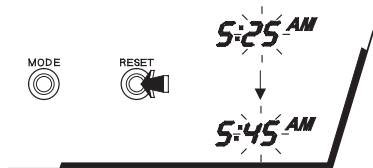

6. To end the adjustment, push the MODE button or turn the ignition switch OFF. The display will stop flashing automatically and the adjustment will be cancelled if the button is not pushed for about 30 seconds.

The clock will be reset AM 1:00 if the battery is disconnected.

## MAJOR COMPONENTS

**(Important Information to operate this vehicle)**

### SUSPENSION

The "Shock Absorber" (1) has 5 adjustment positions for different load or riding conditions.

Use a "Pin Spanner" (2) and "Extension Bar" (3) to adjust the rear shock absorber.

Always adjust the shock absorber position in sequence (1-2-3-4-5 or 5-4-3-2-1).

Attempting to adjust directly from 1 to 5 or 5 to 1 may damage the shock absorber.



Position 1 is for light loads and smooth road conditions. Positions 3 to 5 increase spring preload for a stiffer rear suspension, and can be used when the vehicle is heavily loaded.

Standard position: 2

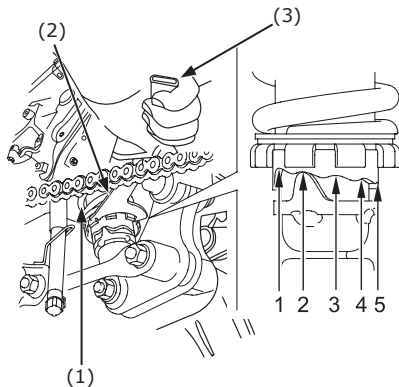

- (1) Shock Absorber
- (2) Pin Spanner
- (3) Extension Bar

## BRAKES

### Front/Rear Brake

This vehicle has a hydraulic front and rear disc brake.

As the brake pads wear, brake fluid level drops.

There are no adjustments to perform, but fluid level and pad wear must be inspected periodically. The system must be inspected frequently to ensure there are no fluid leaks. If the control lever free travel becomes excessive and the brake pads are not worn beyond the recommended limit (page 65), there is probably air in the brake system and it must be bled. Visit your nearest Honda dealer for this service.

### Front Brake Fluid Level:

With the vehicle in an upright position, check the fluid level. It should be above the "LOWER Level Mark" (1). If the level is at

or below the LOWER level mark, check the brake pads for wear (page 65).

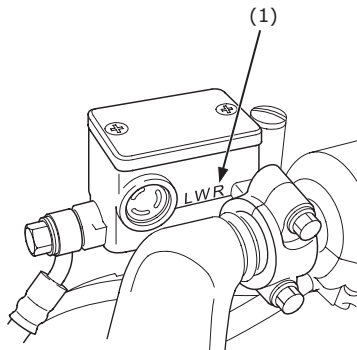

(1) LOWER Level Mark

### Rear Brake Fluid Level:

With the vehicle in an upright position, check the fluid level. It should be between the "UPPER Level Mark" (1) and "LOWER Level Mark" (2). If the level is at or below

the LOWER level mark, check the brake pads for wear (page 65).

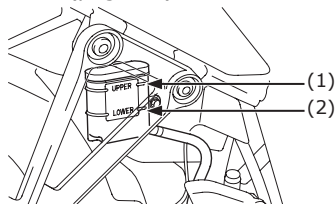

(1) UPPER Level Mark

(2) LOWER Level Mark

Worn pads should be replaced. If the pads are not worn, then brake system inspected for leaks.

The recommended brake fluid is Honda DOT 3 or 4 brake fluid (for Disc) and DOT 4 only (for ABS) from a sealed container, or an equivalent.

### Other Checks:

Make sure there are no fluid leaks. Check for deterioration or cracks in the hoses and fittings.

## CLUTCH

Clutch adjustment may be required if the vehicle stalls when shifting into gear or tends to creep; or if the clutch slips, causing acceleration to lag behind engine speed.

Minor adjustments can be made with the "Clutch Cable Adjuster" (2) at the "Clutch Lever" (1).

Normal clutch lever free play is:  
10 -20 mm(0.4 -0.8 in)

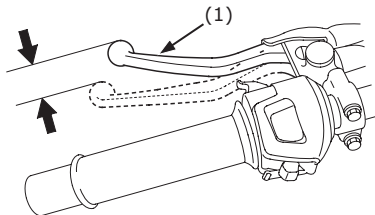

(1) Clutch Lever

1. Pull back the "Rubber Dust Cover" (3).
2. Loosen the "Lock Nut" (4) and turn the clutch cable adjuster. Tighten the lock nut and check the adjustment.

3. If the adjuster is threaded out near its limit or if the correct free play cannot be obtained, using the clutch cable adjuster, loosen the locknut and turn in the clutch cable adjuster completely. Tighten the lock nut and install the rubber dust cover.

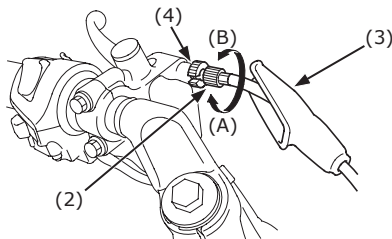

(2) Clutch Cable Adjuster

(3) Rubber Dust Cover

(4) Lock Nut

(A) Increase Free Play

(B) Decrease Free Play

4. Loosen the "Lock Nut" (5) at the lower end of the cable. Turn the "Adjusting Nut" (6)

to obtain the specified free play. Tighten the lock nut and check the adjustment.

5. Start the engine, pull in the clutch lever and shift into gear. Make sure the engine does not stall and the Vehicle does not creep. Gradually release the clutch lever and open the throttle. The vehicle should begin to move smoothly and accelerate gradually.

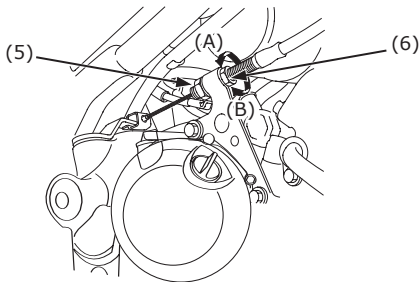

- (5) Lock Nut
- (6) Adjusting Nut
- (A) Increase Free Play
- (B) Decrease Free Play

If proper adjustment cannot be obtained or the clutch does not work correctly, Visit your nearest Honda dealer.

### **Other Checks:**

Check the clutch cable for kinks or signs of wear that could cause sticking or failure. Lubricate the clutch cable with a commercially available cable lubricant to prevent premature wear and corrosion.

## **COOLANT**

### **Coolant Recommendation**

Use only genuine HONDA PRE-MIX COOLANT containing corrosion inhibitors, specifically recommended for aluminium engines when adding or replacing the coolant.

Genuine HONDA PRE-MIX COOLANT is excellent at preventing corrosion and overheating. The effects last for up to 2 years.

The coolant should be inspected and replaced properly by following the maintenance schedule (page 47).

Use any genuine HONDA PRE-MIX COOLANT without diluting with water.

#### **NOTICE**

*Do not use non-ethylene glycol coolant, tap water, nor mineral water when adding or replacing the coolant.*

Use of improper coolant may cause damage, such as corrosions in the engine, blockage of the cooling passage or radiator and premature wear of the water pump seal.

#### **Inspection**

The reserve tank is located under the right side of the crankcase.

Check the coolant level in the "Reserve Tank" (1) while the engine is at the normal operating temperature with the vehicle in an upright position. If the coolant level is below the "Lower Level Mark" (2), remove the "Screw" (3). Pull out the "Prong" (4) from the "Hole" (5). Remove the "Cover" (6) and "Reserve Tank Cap" (7). Add coolant mixture until it reaches the "Upper Level Mark" (8). Always add coolant to the reserve tank.

Do not attempt to add coolant by removing the radiator cap.

If the reserve tank is empty, or if coolant loss is excessive, check for leaks and visit your nearest Honda dealer for repair.

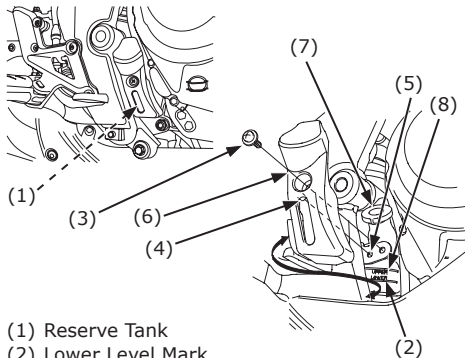

- (1) Reserve Tank
- (2) Lower Level Mark
- (3) Screw
- (4) Prong
- (5) Hole
- (6) Cover
- (7) Reserve Tank Cap
- (8) Upper Level Mark

## FUEL

### Fuel Tank

The fuel tank capacity including the reserve supply is:

13 Ltr. (3.43 US gal , 2.86 Imp gal)

To open the "Fuel Fill Cap" (1), open the "Lock Cover" (2), insert the "Ignition Key"(3) and turn it clockwise. The fuel fill cap will pop up and can be lifted off. Do not overfill the tank. There should be no fuel above the "Level Plate" (4).

After refuelling, to close the fuel fill cap, align the latch in the cap with the slot in the filler neck. Push the fuel fill cap into the filler neck until it snaps closed and locks. Remove the key and close the lock cover.

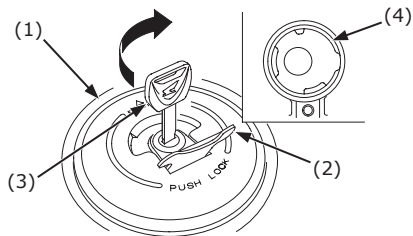

- (1) Fuel Fill Cap
- (2) Lock Cover
- (3) Ignition Key
- (4) Level Plate

### WARNING

Petrol is highly flammable and explosive. You can be burned or seriously injured when handling fuel.

- Stop the engine and keep heat, sparks, and flame away.
- Refuel only outdoors.
- Wipe up spills immediately.

Use unleaded petrol with a research octane number of 91 or higher.

The use of leaded petrol will cause premature damage to the catalytic converter.

#### **NOTICE**

*If "spark knock" or "pinking" occurs at a steady engine speed under normal load, change brands of petrol. If spark knock or pinking persists, consult your Honda dealer. Failure to do so is considered misuse, and damage caused by misuse is not covered by Honda's Limited Warranty.*



#### **WARNING**

Adulterated fuel not to be used. It causes damage to the engine parts and considered as misuse, damage caused by misuse is not covered under Honda warranty.

#### **Petrol Containing Alcohol**

If you decide to use a petrol containing alcohol (gasohol), be sure it's octane rating is at least as high as that recommended by Honda.

Do not use petrol that contains more than 20% ethanol.

- When certain types of petrol containing alcohol are used, problems such as hard starting, poor performance, etc. may occur.
- If you notice any undesirable operating symptoms while using a petrol that contains alcohol, or one that you think contains alcohol, try another station or switch to another brand of petrol.
- When a problem resulting from the use of petrol containing alcohol occurs, contact your Honda dealer.

## EVAPORATIVE EMISSION CONTROL SYSTEM

This vehicle is equipped with evaporative emission (EVAP) canister, which is designed to keep gasoline from evaporating into the atmosphere. Rather than venting a gas tank to the atmosphere.

If the problem occurs, contact your Honda dealer.

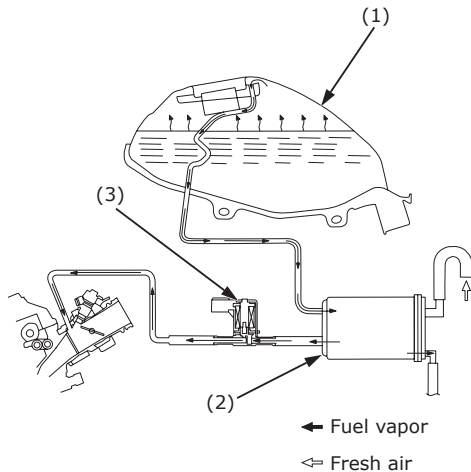

- (1) Fuel tank
- (2) Canister
- (3) Purge control solenoid valve



## ENGINE OIL

### Engine Oil Level Check

Check the engine oil level each day before riding the vehicle.

The level must be maintained between the "Upper Level Mark" (1) and "Lower Level Mark" (2) in the "Inspection Window" (3).

1. Start the engine and let it idle for 3-5 minutes.
2. Stop the engine and hold the vehicle in an upright position on firm, level ground.
3. After 2-3 minutes, check that the oil level should be between the upper and lower level marks in the inspection window.
4. If required, remove the "Oil Filler Cap" (4) and add the specified oil (see page 50) up to the upper level mark. Do not overfill.
5. Reinstall the oil filler cap. Check for oil leaks.

#### NOTICE

*Running the engine with insufficient oil quantity may cause serious engine damage.*

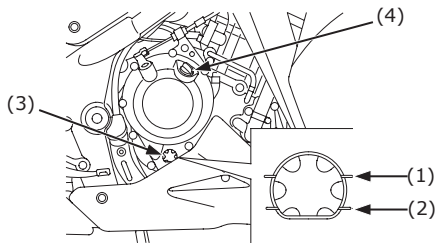

- (1) Upper Level Mark
- (2) Lower Level Mark
- (3) Inspection Window
- (4) Oil Filler Cap

## TYRES

To safely operate your vehicle, your tyres must be the proper type and size, in good condition with adequate tread, and correctly inflated for the load you are carrying. The following pages give more detailed information on how and when to check your air pressure, how to inspect your tyres for damage, and what to do when your tyres need to be repaired or replaced.

### WARNING

Using tyres that are excessively worn or improperly inflated can cause a crash in which you can be seriously hurt or killed.

Follow all instructions in this owner's manual regarding tyre inflation and maintenance.

### Air Pressure

Keeping your tyres properly inflated provides the best combination of handling, tread life and riding comfort. Generally,

under inflated tyres wear unevenly, adversely affect handling, and are more likely to fail from being overheated.

Over inflated tyres make your vehicle ride more harshly, are more prone to damage from road hazards, and wear unevenly.

We recommend that you visually check your tyres before every ride and use a gauge to measure air pressure at least once a month or any time you think the tyres might be low.

Always check air pressure when your tyres are "cold" when the vehicle has been parked for at least three hours. If you check air pressure when your tyres are "warm"- when the vehicle has been ridden for even a few miles - the readings will be higher than if the tyres were "cold". This is normal, so do not let air out of the tyres to match the recommended cold air pressures given below. If you do, the tyres will be under inflated.

The recommended “cold” tyre pressures are:

kPa (kgf/cm <sup>2</sup> , psi)		
Rider Only	Front	200 (2.00 , 29)
	Rear	200 (2.00 , 29)
Rider and One pillion rider	Front	200 (2.00 , 29)
	Rear	225 (2.25 , 33)

This vehicle is fitted with tubeless tyres in both wheels. Compared with ordinary tube tyre, the tubeless tyre releases slow air leak when punctured by a nail or other similar object. For this reason, even though they remain fully inflated, it is important to regularly check the tyre for embedded objects.

### Inspection

Whenever you check the tyre pressures, you should also examine the tyre treads and side walls for wear, damage, and foreign objects:

Look for:

- Bumps or bulges in the side of the tyre or the tread. Replace the tyre if you find any bumps or bulges.

- Cuts, splits or cracks in the tyre. Replace the tyre if you can see fabric or cord.
- Excessive tread wear.

Also, if you hit a pothole or hard object, pull to the side of the road as soon as you safely can and carefully inspect the tyres for damage.

### Tread Wear

Replace tyres before tread depth at the center of the tyre reaches the following limit:

Minimum tread depth	
Front:	1.5 mm (0.06 in)
Rear:	2.0 mm (0.08 in)

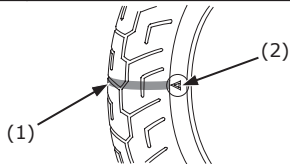

(1) Wear Indicator

(2) Wear Indicator Location Mark

## Tyre Repair

If a tubeless tyre is punctured or damaged, Please visit nearest tyre manufacture dealer and follow his recommendation for repair or replacement.

### CAUTION

Repair/Replacement of tubeless tyre by unauthorized person may render the tyre useless or tyre can fail while driving.

## Tyre Replacement

The tyres that came on your vehicle were designed to match the performance capabilities of your vehicle and provide the best combination of handling, braking, durability and comfort.

### WARNING

Installing improper tyres on your vehicle can affect handling and stability. This can cause a crash in which you can be seriously hurt or killed.

Always use the size and type of tyres recommended in this owner's manual.

The recommended tyres for your vehicle are:

Front: 110/70-17M/C 54S

Rear: 140/70-17M/C 66S

Whenever you replace a tyre, use one that is equivalent to the original and be sure the wheel is balanced after the new tyre is installed.

# ESSENTIAL INDIVIDUAL COMPONENTS

## IGNITION SWITCH

The “Ignition Switch” (1) is below the instrument panel.

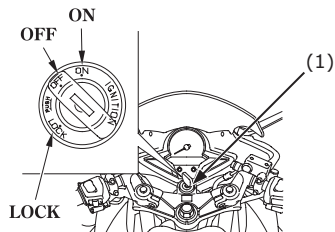

(1) Ignition Switch

Key Position	Function	Key Removal
LOCK (steering lock)	Steering is Locked. Engine and lights cannot be operated.	Key can be removed
OFF	Engine and lights cannot be operated.	Key can be removed
ON	Engine can be operated Turn signal, passing light control switch and horn can be operated. Headlight, Position light, meter light and tail light will glow.	Key cannot be removed

## RIGHT HANDLEBAR CONTROLS

### NOTICE

#### **Automatic Headlamp ON (AHO Compliance):-**

*This means that the Headlamp will get ON as soon as the ignition switch is ON.*

*There is no switch to turn OFF the Headlamp while riding. "Automatic Headlamp ON" feature of your vehicle helps other to recognize your vehicle position in foggy/dusty environment condition.*

#### **Engine Stop Switch**

The "Engine Stop Switch" (1) is next to the throttle grip. When the switch is in the ○ (RUN) position, the engine will operate. When the switch is in the ⊗ (OFF) position, the engine will not operate. This switch is intended primarily as an emergency switch and should normally remain in the ○ (RUN) position.

#### **Starter Button**

The "Starter Button" (2) is below the headlight switch.

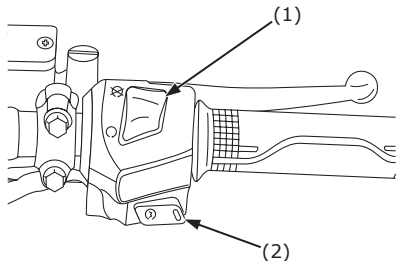

When the starter button is pressed the starter motor cranks the engine. See page 39 for the starting procedure.



- (1) Engine Stop Switch
- (2) Starter Button

## LEFT HANDLEBAR CONTROLS



### Headlight Dimmer Switch (1)

Push the dimmer switch to  (HI) to select high beam or to  (LO) to select low beam.

### Passing Light Control Switch (2)

When this switch is pressed, the headlight flashes on to signal approaching cars or when passing.

### Turn Signal Switch (3)

Move to  (L) to signal a left turn,  (R) to signal a right turn. Press to turn signal off.

### Horn Button (4)

Press the button to sound the horn.

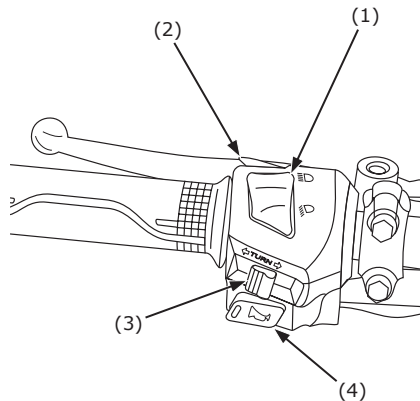

- (1) Headlight Dimmer Switch
- (2) Passing Light Control Switch
- (3) Turn Signal Switch
- (4) Horn Button

## FEATURES

(Not required for operation)

### STEERING LOCK

To lock the steering, turn the handlebar all the way to the left, turn the "Ignition Key"(1) to LOCK while pushing in. Remove the key. To unlock the steering, turn the key to OFF.

Do not turn the key to LOCK while riding the vehicle; loss of vehicle control will result.

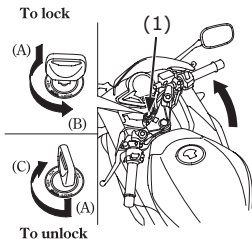

- (1) Ignition Key
- (A) Push in
- (B) Turn to LOCK
- (C) Turn to OFF

## SEAT

### Rear seat

To remove the "Rear Seat" (1), insert the "Ignition Key" (2) into the "Seat Lock" (3). Turn it clockwise, then pull the rear seat up and back.

To install the rear seat, insert the "Prongs"(4) into the "Rear Stays" (5) on the frame, and then push down on the rear of the rear seat. Be sure the seat is locked securely in position after installation.

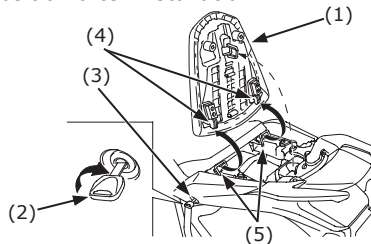

- (1) Rear Seat
- (2) Ignition Key
- (3) Seat Lock
- (4) Prongs
- (5) Rear Stays



## Front seat

To remove the "Front Seat" (1), remove the rear seat (page 34) and mounting "Bolts" (2), and then pull the seat back and up.

To install the front seat, insert the "Tab" (3) into the recess under the frame and tighten the mounting bolts securely.

Install the rear seat.

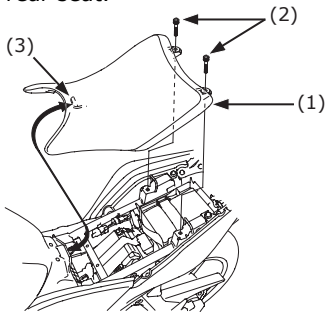

- (1) Front Seat
- (2) Mounting Bolts
- (3) Tab

## HELMET HOLDER

The helmet holder is located below the rear seat.

Remove the rear seat (page 34). Route the "Helmet Wire" (1) through the "Helmet D-ring" (2) and hook the loops of the helmet wire onto the "Helmet Holder" (3).

Install the rear seat and lock it securely.

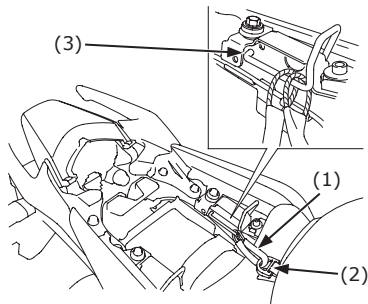

- (1) Helmet Wire
- (2) Helmet D-ring
- (3) Helmet Holder

## **⚠ WARNING**

Riding with a helmet attached to the holder can interfere with the rear wheel or suspension and could cause a crash in which you can be seriously hurt or killed. Use the helmet holder only while parked. Do not ride with a helmet secured by the holder.

## **DOCUMENT & STORAGE COMPARTMENT**

The "Documents" (1) and "Storage" (2) compartment is under the rear seat (page 34).

The Owner's Manual and other documents should be stored in the document bag. When washing your vehicle, be careful not to flood this area with water.

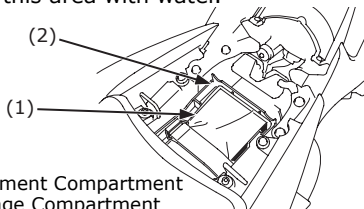

- (1) Document Compartment
- (2) Storage Compartment

## **RIGHT UNDER COWL**

The right under cowl must be removed to service the oil filter.

Removal:

1. Remove the "Bolt A" (1) and "Bolts B"(2).
2. Remove the "Hooks" (3) from the "Slots" (4).
3. Remove the "Middle Cowl" (5) and disconnect the "Front Turn Signal Connectors" (6).

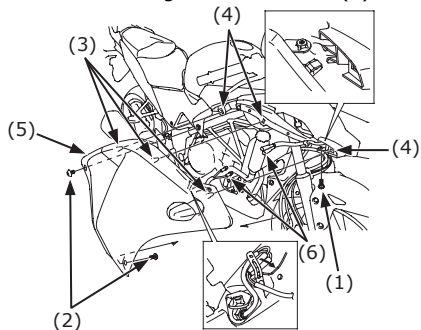

- (1) Bolt A
- (2) Bolts B
- (3) Hooks
- (4) Slots
- (5) Middle Cowl
- (6) Front Turn Signal Connectors

- Be careful not to apply weight to the middle cowl.
  - Carefully release the hooks.
4. Remove the "Right Under Cowl" (7) by removing the "Bolt C" (8), "Bolt D" (9) and "Screw" (10).

### Installation:

Installation can be done in the reverse order of removal.

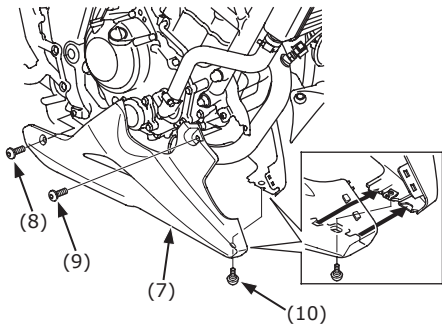

- (7) Right under cowl      (8) Bolt C  
 (9) Bolts D                      (10) Screw

## HEADLIGHT AIM VERTICAL ADJUSTMENT

Vertical adjustment can be made by turning the "Pinion" (1) in or out as necessary.

Obey local laws and regulations.

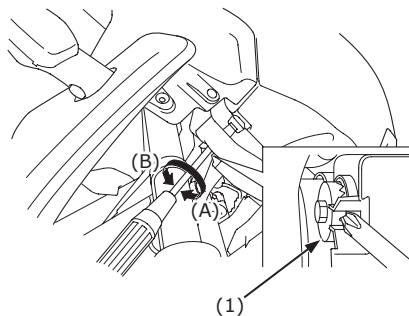

- (1) Pinion  
 (A) Up  
 (B) Down

## OPERATION

### PRE-RIDE INSPECTION

For your safety, it is very important to take a few moments before each ride to walk around your vehicle and check its condition. If you detect any problem, be sure you take care of it, or have it corrected by your Honda dealer.

#### **WARNING**

Improperly maintaining this vehicle or failing to correct a problem before riding can cause a crash in which you can be seriously hurt or killed.

Always perform a pre-ride inspection before every ride and correct any problems.

1. Engine oil level - add engine oil if required (page 27). Check for leaks.
2. Fuel level - fill fuel tank when necessary (page 24). Check for leaks.

3. Coolant level - add coolant if required (page 22). Check for leaks.
4. Front and rear brakes - check operation; make sure there is no brake fluid leakage (pages 19-20).
5. Tyres - check condition and pressure (pages 28-30).
6. Drive chain - check condition and slack (page 56). Adjust and lubricate if necessary.
7. Throttle - check for smooth opening and full closing in all steering positions (page 53).
8. Clutch - check operation, and adjust if necessary (pages 21-22).
9. Lights and horn - check that turn signals, indicators and horn function properly.
10. Engine stop switch - check for proper function (page 32).

### STARTING THE ENGINE

Always follow the proper starting procedure described below.

To protect the catalytic converter in your vehicle's exhaust system, avoid extending idling and the use of leaded petrol.

Your vehicle's exhaust contains poisonous carbon monoxide gas. High levels of carbon monoxide can collect rapidly in enclosed areas such as a garage.

Do not run the engine with the garage door closed. Even with the door open, run the engine only long enough to move your vehicle out of the garage.

Do not use the electric starter for more than 5 second at a time. Release the starter button for approximately 10 seconds before pressing it again.

### **Preparation**

Before starting, insert the key, turn the ignition switch ON and confirm the following:

- The transmission is in NEUTRAL (neutral indicator light is ON).
- The engine stop switch in at  (RUN).
- The ABS indicator is ON. (CBR250RAJ).
- The PGM-FI malfunction indicator lamp (MIL) is OFF.

### **(CBR250RAJ)**

The ABS indicator should go off after you ride the vehicle at a speed above 10 km/h (6 mph).

### **Starting Procedure**

This vehicle has a fuel-injected engine with an automatic choke. Follow the procedure indicated below.

### **Any Air Temperature:**

- With the throttle completely closed, press the start button.

The engine will not start if the throttle is fully open (because the electronic control module cuts off the fuel supply).

### **Flooded Engine**

If the engine fails to start after repeated attempts, it may be flooded.

1. Open the throttle fully.
2. Press the start button for 5 seconds.
3. Follow the normal starting procedure.
4. If the engine starts with unstable idle, open the throttleslightly. If the engine does not start, wait for 10 seconds, then follow steps 1 -3 again.

## Ignition Cut Off

Your vehicle is designed to automatically stop the engine and fuel pump if the vehicle is over-turned (a banking sensor cuts off the ignition system). Before restarting the engine, you must turn the ignition switch to the OFF position and then back to ON.

## RUNNING-IN

Help assure your vehicle's future reliability and performance by paying extra attention to how you ride during the first 500 km (300 miles).

During this period, avoid full-throttle starts and rapid acceleration.

## RIDING

Review Vehicle Safety (page 3-7) before you ride.

Make sure the side stand is fully retracted before riding the vehicle. If the stand is extended, it may interfere with control during a left turn.

Make sure flammable materials such as dry grass or leaves do not come in contact with the exhaust system when riding, idling, or parking your vehicle.

1. After the engine has been warmed up, the vehicle is ready for riding.
2. While the engine is idling, pull in the clutch lever and depress the gearshift pedal to shift into 1st (low) gear.
3. Slowly release the clutch lever and at the same time gradually increase engine speed by opening the throttle. Co-ordination of the throttle and clutch lever will assure a smooth positive start.
4. When the vehicle attains a moderate speed, close the throttle, pull in the clutch lever and shift to 2nd gear by raising the gearshift pedal. This sequence is repeated to progressively shift to 3rd, 4th, 5th and 6th (top) gear.

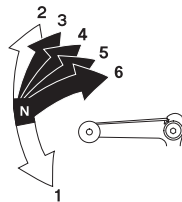

5. Coordinate the throttle and brakes for smooth deceleration.
6. Both front and rear brakes should be used at the same time and should not be applied strongly enough to lock the wheel, or braking effectiveness will be reduced and control of the vehicle be difficult.

### **BRAKING**

Your vehicle is equipped with a hydraulically-activated disc brake in front and rear. Operating the brake lever applies the front disc brake. Pressing the brake pedal applies the rear disc brake.

For normal braking, apply both the brake pedal and lever while down-shifting to match your road speed. For maximum braking, close the throttle and firmly apply the pedal and lever; pull in the clutch lever before coming to a complete stop to prevent stalling the engine.

#### **Important Safety Reminders:**

- Independent operation of only the brake lever or brake pedal reduces stopping performance.

- Extreme application of the brake controls may cause wheel lock, reducing control of the vehicle.
- When possible, reduce speed or brake before entering a turn; closing the throttle or braking in mid-turn may cause wheel slip. Wheel slip will reduce control of the vehicle.
- When riding in wet or rainy conditions, or on loose surfaces, the ability to maneuver and stop will be reduced. All of your actions should be smooth under these conditions. Rapid acceleration, braking or turning may cause loss of control. For your safety, exercise extreme caution when braking, accelerating or turning.
- When descending a long, steep grade, use engine compression braking by downshifting, with intermittent use of both brakes.
- Continuous brake application can overheat the brakes and reduce their effectiveness.

- Riding with your foot resting on the brake pedal or your hand on the brake lever may actuate the brake light, giving a false indication to other drivers. It may also overheat the brakes, reducing effectiveness.

### **Anti-Lock Brake System (ABS) (CBR250RAJ)**

This vehicle is equipped with 2 Channel ABS. Operating the front brake lever applies the front brake. Operating the rear brake pedal applies the rear brake. For full braking effectiveness, use both the lever and pedal simultaneously, as you would with a conventional vehicle braking system. As with a conventional vehicle braking system, excessively hard application of the brake controls may cause wheel lock, reducing control of the vehicle.

Anti-lock Brake System (ABS) designed to help prevent wheel lock during hard braking on uneven or other poor surfaces while running straight. Although the wheel may not lock if you are braking too hard in a turn the vehicle can still lose traction, causing a loss of control.

In some situations, a vehicle with ABS may require a longer stopping distance to stop on loose or uneven surfaces than an equivalent vehicle without ABS.

ABS cannot make up for road conditions, bad judgment, or improper operation of the brakes. It is still your responsibility to ride at reasonable speeds for weather, road surface, and traffic conditions, and to leave a margin of safety.

- ABS is self-checking and always ON.
- ABS may be activated by riding over a sharp drop or rise in the road level. It is important to follow the tyre recommendations (page 30). The ABS control unit works by comparing wheel speed. Always use the recommended front/rear tires and sprockets to ensure correct ABS operation.
- ABS does not function at low speeds (approximately 10 km/h (6 mph) or below).



- The brake lever and pedal may recoil slightly when applying the brakes. This is normal.
- ABS does not function if the battery is discharged.

### **ABS Indicator (CBR250RAJ)**

Normally, this indicator comes on when the ignition is turned ON, and goes off after you ride the vehicle at speed above 10km/h (6 mph). If there is an ABS problem, the indicator flashes and remains on. The ABS system does not operate when the ABS indicator is on.

If the ABS indicator comes on while riding, stop the vehicle in a safe place and turn off the engine.

Turn the ignition ON again. The indicator should come on, and go off after you ride the vehicle at speeds above 10 km/h (6 mph). If it does not go off, ABS is not functioning, but the brakes still work as normal Brake System and provide normal stopping ability. However, you should have the system checked by your Honda dealer as soon as possible.

The ABS indicator may flash if you turn the rear wheel while the vehicle is upright on the stand. This is normal. Turn the ignition OFF, then turn it ON. The indicator should come on, then go off after you run the vehicle above 10 km/h (6 mph).

### **PARKING**

1. After stopping the vehicle, shift the transmission into neutral, turn the handlebar fully to the left, turn the ignition switch OFF and remove the key.
2. Use the side stand to support the vehicle while parked.  
Park the vehicle on firm, level ground to prevent it from falling --over. If you must park on a slight incline, aim the front of the vehicle uphill to reduce the possibility of rolling off the side stand or overturning.
3. Lock the steering to help prevent theft (page 7).

The exhaust pipe and muffler become very hot during operation and remain sufficiently hot to inflict burns if touched even after shutting off the engine.

Make sure flammable materials such as dry grass or leaves do not come in contact with the exhaust system when parking your vehicle.

## **MAINTENANCE**

### **THE IMPORTANCE OF MAINTENANCE**

A well-maintained vehicle is essential for safe, economical and trouble-free riding. It will also help reduce air pollution.

To help you properly care for your vehicle, the following pages include a Maintenance Schedule and a maintenance Record for regularly scheduled maintenance.

These instructions are based on the assumption that the vehicle will be used exclusively for its designed purpose. Sustained high speed operation or operation in unusually wet or dusty conditions will require more frequent service than specified in the Maintenance Schedule. Consult your Honda dealer for recommendations applicable to your individual needs and use. If your vehicle overturns or becomes involved in a crash, be sure your Honda dealer inspects all major parts, even if you are able to make some repairs.

## **WARNING**

Improperly maintaining this vehicle or failing to correct a problem before you ride can cause a crash in which you can be seriously hurt or killed.

Always follow the inspection and maintenance recommendations and schedules in this owner's manual.

### **MAINTENANCE SAFETY**

This section includes instructions on some important maintenance tasks. You can perform some of these tasks with the tools provided if you have basic mechanical skills.

Other tasks that are more difficult and require special tools are best performed by professionals. Wheel removal should normally be handled only by a Honda technician or other qualified mechanic; instructions are included in this manual only to assist in emergency service.

Some of the most important safety precautions follow. However, we cannot warn you of every conceivable hazard that can arise in performing maintenance. Only you can decide whether or not you should perform a given task.

## **WARNING**

Failure to properly follow maintenance instructions and precautions can cause you to be seriously hurt or killed.

Always follow the procedures and precautions in this owner's manual.

### **SAFETY PRECAUTIONS**

- Make sure the engine is off before you begin any maintenance or repairs. This will help eliminate several potential hazards:
  - \* **Carbon monoxide poisoning from engine exhaust.**  
Be sure there is adequate ventilation whenever you operate the engine.
  - \* **Burns from hot parts.**  
Let the engine and exhaust system cool before touching.

### \* **Injury from moving parts.**

Do not run the engine unless instructed to do so.

- Read the instructions before you begin and make sure you have the tools and skills required.
- To help prevent the vehicle from falling over, park it on a firm, level surface, using the side stand or a maintenance stand to provide support.
- To reduce the possibility of a fire or explosion, be careful when working around petrol or batteries. Use only nonflammable solvent, not petrol, to clean parts. Keep cigarettes, sparks and flames away from the battery and all fuel-related parts.

Remember that your Honda dealer knows your vehicle best and is fully equipped to maintain and repair it.

To ensure the best quality and reliability, use only new genuine Honda parts or their equivalents for repair and replacement.

## **MAINTENANCE SCHEDULE**

Perform the pre-ride Inspection (Ref. page 38) at each scheduled maintenance period.

**I: INSPECT, CLEAN, ADJUST, LUBRICATE OR REPLACE IF NECESSARY**

**C: CLEAN R: REPLACE A: ADJUST L: LUBRICATE.**

The following Maintenance Schedule specifies all maintenance required to keep your vehicle in peak operating condition. Maintenance work should be performed in accordance with standards and specifications of Honda by properly trained and equipped technicians. Your Honda dealer meets all of these requirements.

- \* Should be serviced by your Honda dealer, unless the owner has the proper tools and service data and is mechanically qualified. Refer to the Official Honda Shop Manual.
- \*\* In the interest of safety, we recommend these items be serviced only by your Honda dealer.

Honda recommends that your Honda dealer should road test your vehicle after each periodic maintenance is carried out.

- NOTES: (1) At higher odometer reading, repeat at the frequency interval established here.
- (2) Service more frequently when riding in unusually wet or dusty areas.
  - (3) Service more frequently when riding in rain or at full throttle.
  - (4) Replacement requires mechanical skill.

ITEM	FREQUENCY	NOTE	ODOMETER READING (NOTE 1)							
			x1000Km	1	6	12	18	24	30	36
			x1000mi	0.6	4	8	12	16	20	24
			MONTHS	1	6	12	18	24	30	36
*	FUEL LINE				I		I		I	
*	THROTTLE OPERATION				I		I		I	
	AIR CLEANER	(NOTE 2)					R		R	
	CRANKCASE BREATHER	(NOTE 3)			C	C	C	C	C	
*	SPARK PLUG		EVERY 24000 Km (16000mi) I, EVERY 48000 Km (30000mi) R							
*	VALVE CLEARANCE			I				I		
	ENGINE OIL			R	R	R	R	R	R	
	ENGINE OIL FILTER			R		R		R	R	
*	ENGINE IDLE SPEED			I	I	I	I	I	I	
**	FUEL FILTER (IN type only)		EVERY 48000 Km (30000mi) R							
	RADIATOR COOLANT	(NOTE 4)				I		I	R	
*	COOLING SYSTEM					I		I	I	
*	SECONDARY AIR SUPPLY SYSTEM					I		I	I	
*	EVAPORATIVE EMISSION CONTROL SYSTEM						I		I	
	DRIVE CHAIN		EVERY 1000 km (600 mil)I, L							
	DRIVE CHAIN SLIDER					I		I	I	

The vehicle must be serviced at every 6000 kms or within 6 months whichever is earlier from the date of previous service. For NOTES refer page 46.

ITEM	FREQUENCY	NOTE	ODOMETER READING (NOTE 1)							
			x1000Km	1	6	12	18	24	30	36
			x1000mi	0.6	4	8	12	16	20	24
			MONTHS	1	6	12	18	24	30	36
*	BATTERY VOLTAGE			I	I	I	I	I	I	I
	BRAKE FLUID	(NOTE 4)			I	I	R	I	I	R
	BRAKE PADS WEAR				I	I	I	I	I	I
	BRAKE SYSTEM			I		I		I		I
*	BRAKE LIGHT SWITCH					I		I		I
*	HEADLIGHT AIM					I		I		I
	LIGHTS/HORN				I	I	I	I	I	I
	CLUTCH SYSTEM			I	I	I	I	I	I	I
	SIDE STAND					I		I		I
*	SUSPENSION					I		I		I
*	NUTS, BOLTS, FASTENERS			I		I		I		I
**	WHEELS/TYRES					I		I		I
**	STEERING HEAD BEARINGS			I		I		I		I

The vehicle must be serviced at every 6000 kms or within 6 months whichever is earlier from the date of previous service. For NOTES refer page 46.

## TOOL KIT & FIRST AID KIT

The "Tool Kit" (1) and "First Aid Kit" (2) is in the storage compartment under the rear seat (page 34).

Some roadside repairs, minor adjustments and parts replacement can be performed with the tools contained in the kit.

- Spanner 8x12
- Spanner 10x14
- Handle Eye Wrench, 12 mm
- Driver, No.2 Plus Minus
- Wire Helmet Set
- Eye Wrench 24
- Eye Wrench 19
- Hex Wrench 5
- Pin Spanner
- Tool Bag
- Grip

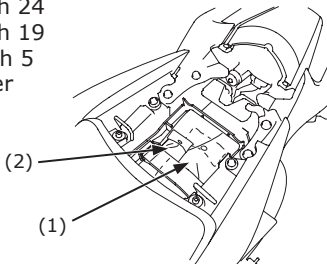

(1) Tool Kit

(2) First Aid Kit

## COLOR CODE

The color table is attached below.

It is useful during ordering the replacement parts.

S. No.	Color	Color Code
1	Mat Axis Gray Metallic	NH-303M
2	Sports Red	R-321
3	Pearl Sports Yellow	Y-206P
4	Vibrant Orange	YR-250

The above color code table helps in providing the correct color part as per your vehicle color.

## ENGINE OIL

Refer to the Safety Precautions on page 45.

### Engine Oil

Good engine oil has many desirable qualities. Use only high detergent, quality motor oil certified on the container to meet or exceed requirements for API Service Classification MA

### Viscosity:

Viscosity grade of engine oil should be based on average atmospheric temperature in your riding area. The following provides a guide to the selection of the proper grade or viscosity of oil to be used at various atmospheric temperatures.

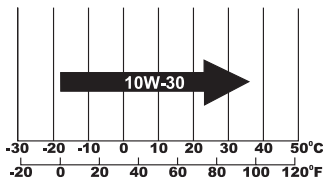

## Engine Oil and Filter

Engine oil quality is the chief factor affecting engine service life. Change the engine oil as specified in the maintenance schedule (page 47).

When running in very dusty conditions, oil changes should be performed more frequently than specified in the maintenance schedule.

**Please dispose of used engine oil in a manner that is compatible with the environment. We suggest you take it in a sealed container to your local recycling center or service station for reclamation. Do not throw it in the trash or pour it on the ground or down a drain.**

Used engine oil may cause skin cancer if repeatedly left in contact with the skin for prolonged periods. Although this is unlikely unless you handle used oil on a daily basis, it is still advisable to thoroughly wash your hands with soap and water as soon as possible after handling used oil.



Changing the oil filter requires a torque wrench. If you do not have it and the necessary skill, we recommend that you have your Honda dealer perform this service.

If a torque wrench is not used for this installation, visit your nearest Honda dealer as soon as possible to verify proper assembly. Change the engine oil with the engine at normal operating temperature and the vehicle on its side stand to assure complete and rapid draining.

1. Place a drain pan under the crankcase.
2. To drain the oil, remove the oil filler cap, "Oil Drain Bolt" (1) and "Sealing Washer" (2).

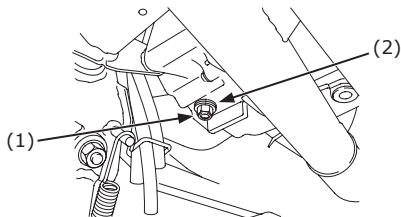

- (1) Oil Drain Bolt  
(2) Sealing Washer

3. Remove the right under cowl (page 36).
4. Remove the "Oil Filter Cover" (3), "Gasket" (4) "Spring" (5) and "Oil Filter" (6), by removing the "Oil Filter Cover Bolt" (7).
5. Install the new oil filter with the "OUT-SIDE Mark" (8) facing out.

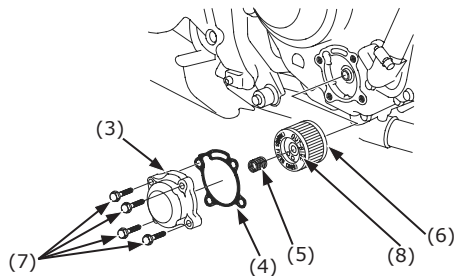

- (3) Oil Filter Cover  
(4) Gasket  
(5) Spring  
(6) Oil Filter  
(7) Oil Filter Cover Bolt  
(8) "OUT-SIDE" Mark

Use only the Honda Genuine oil filter or a filter of equivalent quality specified for your model. Using wrong filter or a non-Honda filter which is not of equivalent quality may cause engine damage.

**NOTICE**

Improper installation of the oil filter can cause serious engine damage.

6. Install the oil filter spring into the oil filter cover. Then, install the new gasket and oil filter cover.

Make sure the oil filter cover bolts are tightened securely to the specified torque.

Oil filter cover bolts torque:

**12 N·m (1.2 kgf·m , 9 lbf·ft)**

7. Check that the sealing washer on the drain bolt is in good condition and install the bolt. Replace the sealing washer every other time the oil is changed, or each time if necessary.

Engine oil drain bolt torque:

**24 N·m (2.4 kgf·m , 18 lbf·ft)**

8. Fill the crankcase with the recommended grade oil; approximately:

1.4 L (1.5 US qt , 1.2 Imp qt)  
without oil filter

1.5 L (1.6 US qt , 1.3 Imp qt)  
with oil filter

9. Install the oil filler cap.
10. Start the engine and let it idle for 3 - 5 minutes.
11. 2 - 3 minutes after stopping the engine, check that the oil level is at the upper level mark in the inspection window with the vehicle upright on firm, level ground. Make sure there are no oil leaks.

## CRANKCASE BREATHER

Refer to the Safety Precautions on page 45.

1. Remove the "Crankcase Breather Tube Plug" (1) from the tube and drain deposits into a suitable container.
2. Reinstall the crankcase breather tube plug.

Service more frequently when riding in rain or at full throttle.

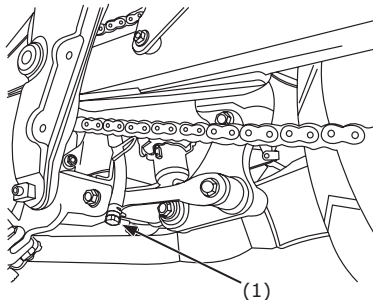

(1) Crankcase breather tube plug

## THROTTLE OPERATION

Refer to the Safety Precautions on page 45.

1. Check for smooth rotation of the throttle grip from the fully open to the fully closed position at both full steering positions.
2. Measure the throttle grip free play at the throttle grip flange.  
The standard free play should be approximately:  
2-6 mm (0.1-0.2 in)

To adjust the free play, slide the "Throttle Cable Boot" (1), then loosen the "Lock Nut" (2) and turn the "Adjuster" (3).

After adjustment, tighten the lock nut and return the throttle cable boot securely.

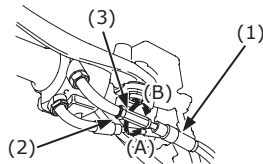

- (1) Throttle cable boot (2) Lock nut  
(3) Adjuster (A) Increase  
(B) Decrease

## COOLANT

Refer to the Safety Precautions on page 45.

### Coolant Replacement

Coolant should be replaced by your Honda dealer, unless the owner has proper tools and service data and is mechanically qualified. Refer to an official Honda Shop Manual.

Always add coolant to the reserve tank. Do not attempt to add coolant by removing the radiator cap.

### WARNING

Removing the radiator cap while the engine is hot can cause the coolant to spray out, seriously scalding you.

Always let the engine and radiator cool down before removing the radiator cap.

## AIR CLEANER

Refer to the Safety Precautions on page 45.

The air cleaner element should be replaced at regular intervals (page 47). Replace more frequently when riding in unusually wet or dusty areas.

1. Remove the rear & front seat (page 34-35).
2. Remove the "Air Cleaner Case Cover" (1) by removing the "Screws" (2).
3. Remove the "Air Cleaner Element" (3) by pushing the "Tabs" (4).
4. Install the new air cleaner element. Make sure the air cleaner element is fixed. Use the Honda Genuine air cleaner element or an equivalent air cleaner element specified for your model. Using the wrong Honda air cleaner element or a non-Honda air cleaner element which is not of equivalent quality may cause premature engine wear or performance problems.

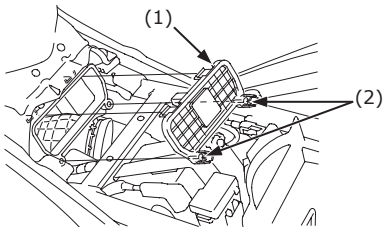

(1) Air Cleaner Case Cover

(2) Screws

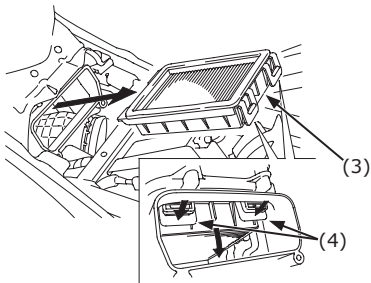

(3) Air Cleaner Element

(4) Tabs

5. If the filter element is cleaned using pressured air or any solvent, viscous oil will be lost and as the base element is coarse paper, dust may enter along with air which will damage the engine.
6. Replace the air cleaner element if it is excessively dirty, torn or damage.
7. Install the removed parts in the reverse order of removal.

## **⚠ CAUTION**

Never clean air cleaner element. Replacement should be done at regular intervals

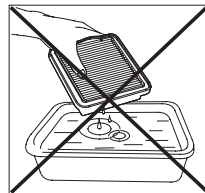
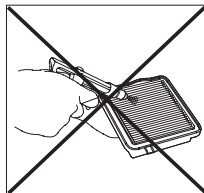

## DRIVE CHAIN

Refer to the safety precautions on page 45.

The service life of the "Drive Chain" (1) is dependent upon proper lubrication and adjustment. Poor maintenance can cause premature wear or damage to the drive chain and sprockets.

The drive chain should be checked and lubricated as part of the pre-ride Inspection (page 38). Under severe usage, or when the vehicle is ridden in unusually dusty or muddy areas, more frequent maintenance will be necessary.

### Inspection:

1. Turn the engine off, place the vehicle on its side stand, and shift the transmission into neutral.
2. Move the chain up and down with your finger. Drive chain slack should be adjusted approximately to allow the following vertical movement by hand:

Chain slack should be:

20-30 mm (0.8 - 1.2 in)

3. Roll the vehicle forward and then stop to check the drive chain slackness again. Repeat this procedure several times. Drive chain slack should remain constant. If the chain is slack only in certain sections, some links are kinked and binding. Binding and kinking can be eliminated by lubrication.

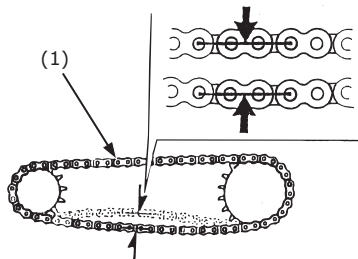

(1) Drive Chain

4. Roll the vehicle forward. Stop and place it on its side stand. Inspect the drive chain and sprockets for any of the following conditions :

## DRIVE CHAIN

- Damaged Rollers
- Loose pins
- Dry or Rusted Links
- Kinked or Binding Links
- Excessive Wear
- Improper Adjustment
- Damaged or Missing O-ring

## SPROCKETS

- Excessively Worn Teeth
- Broken or Damaged Teeth

A drive chain with damaged rollers, loose pins or missing O-rings must be replaced. The rusting, requires supplementary lubrication. Kinked or binding links should be thoroughly lubricated and worked free. If links cannot be freed, the chain must be replaced.

Damaged sprocket  
Teeth

**Replace**

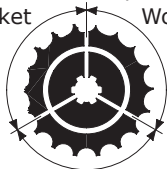

Worn sprocket  
Teeth

**Replace**

Normal sprocket Teeth

**GOOD**

## Adjustment:

Drive chain slack should be checked and adjusted, if necessary, every 1,000 km (600 miles). When operated at sustained high speeds or under conditions of frequent rapid acceleration, the chain may require more frequent adjustment.

If the drive chain requires adjustment, the procedure is as follows:

1. Place the vehicle on its side stand with the transmission in neutral and the ignition switch OFF.
2. Loosen the "Rear Axle Nut" (1).
3. Loosen the "Drive Chain Lock Nuts" (2) on the both sides of swingarm.
4. Turn both "Drive Chain Adjusting Nuts"(3) an equal number of turns until the correct drive chain slack is obtained. Turn the drive chain adjusting nuts clockwise to tighten the chain, or counterclockwise to provide more slack. Adjust the chain slack at a point midway between the drive sprocket and the rear wheel sprocket.

Roll the vehicle forward. Stop and place it on its side stand. Recheck chain slack.

5. Check rear axle alignment by making sure the "Chain Adjuster Index Marks" (4) align with the "Rear Edge of Adjusting Slot" (5).

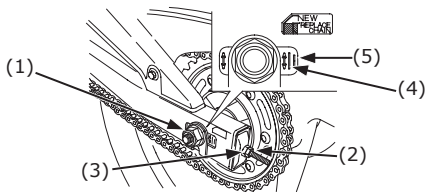

- (1) Rear Axle Nut  
(2) Drive Chain Lock Nut  
(3) Drive Chain Adjusting Nut  
(4) Chain Adjuster Index Marks  
(5) Rear Edge of Adjusting Slot

Both left and right marks should correspond. If the axle is misaligned, turn the left or right adjusting nut until the marks correspond on the rear edge of the adjusting slots and recheck chain slack.

6. Tighten the rear axle nut to the specified torque.

Rear axle nut torque:

**88 N·m (9.0 kgf·m , 65 lbf·ft)**

If a torque wrench is not used for this installation, visit your nearest Honda dealer as soon as possible to verify proper assembly.

7. Tighten the drive chain adjusting nuts lightly, then tighten the drive chain lock nuts by holding the drive chain adjusting nuts with a spanner.  
8. Recheck drive chain slack.

### **Wear Inspection:**

Check the chain wear label when adjusting the chain. If the "Red Zone" (6) on the label aligns with the "Arrow Mark" (7) on the chain adjuster plates after the chain has been adjusted to the proper slack, the chain is excessively worn and must be replaced. The proper slack is :

20 - 30 mm (0.8 - 1.2 in)

Damage to the bottom part of the frame may be caused by excessive drive chain slack of more than:

50 mm (2.0 in)



This vehicle has a staked master link drive chain. If chain adjustment done upto maximum level (Red Zone) than replace chain. Visit your nearest Honda dealer

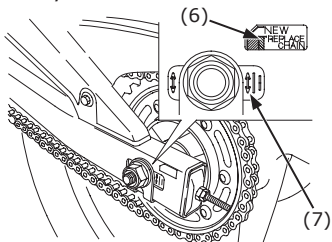

(6) Red Zone

(7) Arrow Mark

### Lubrication and Cleaning:

This vehicle is equipped with seal type chain hence proper care needs to be taken during its cleaning and lubrication. Lubricate every 1,000 km (600 miles) or sooner if chain appears dry.

After inspecting the slack, clean the chain and sprockets while rotating the rear wheel. Use dry cloth with chain cleaner designed specifically for O-ring chains, or neutral detergent. Use a soft brush if the chain is dirty.

After cleaning, wipe dry and lubricate with drive chain lubricant designed specifically for O-ring chains. If not available, use SAE 80 or 90 gear oil.

Do not use a steam cleaner, a high pressure cleaner, a wire brush, volatile solvent such as gasoline and benzene, abrasive cleaner, chain cleaner or lubricant not designed specifically for O-ring chains as these can damage the rubber O-ring seals.

Avoid getting lubricant on the brakes or tyres. Avoid applying excess chain lubricant to prevent spray onto your clothes and the vehicle.

Replacement chain:

Type: Endless O-ring

Size: 520, Link: 108

### NOTICE

*However for lubrication and cleaning, please contact Honda authorized service center.*

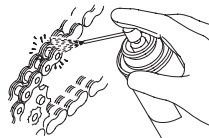

## DRIVE CHAIN SLIDER

Refer to the Safety Precautions on page 45. Check the "Chain Slider" (1) for wear.

The chain slider must be replaced if it is worn to the "Wear Limit Line" (2). For replacement, visit your nearest Honda dealer.

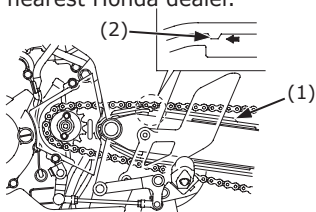

(1) Chain Slider

(2) Wear Limit Line

## FRONT AND REAR SUSPENSION INSPECTION

Refer to the Safety Precautions on page 45.

1. Check the front fork assembly by locking the front brake and pumping the fork up and down vigorously. Suspension action should be smooth and there must be no oil leakage.

2. Rear fork bushing - this can be checked by pushing hard against the side of the rear wheel while the vehicle is on a support block. Feeling for looseness of the fork bushings.
3. Carefully inspect all front and rear suspension fasteners for tightness.

## SIDE STAND

Refer to the Safety Precautions on page 45.

Check the "Side Stand Spring" (1) for damage and loss of tension, and the side stand assembly for freedom of movement.

If the side stand is squeaky or stiff, clean the pivot area and lubricate the pivot bolt with clean engine oil.

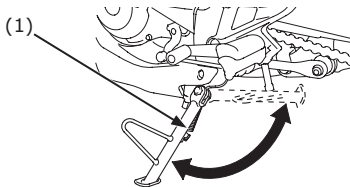

(1) Side Stand Spring

## WHEEL REMOVAL

Refer to the Safety Precautions on page 45.

This vehicle is equipped with a side stand only. Therefore, if front or rear wheel removal is required, it will be necessary to raise the center of the vehicle with a jack or other firm support. If none is available, visit your nearest Honda dealer for this service.

### (CBR250RAJ only)

When removing and installing the wheel, be careful not to damage the wheel speed sensor and pulser ring.

### Front Wheel Removal

1. Support the vehicle securely and raise the front wheel off the ground using a safety stand or a hoist.
2. Remove the "Front Axle Nut" (1).
3. Loosen the "Axle Pinch Bolt" (2).
4. Remove the "Front Axle Shaft" (3), front wheel and side collar.

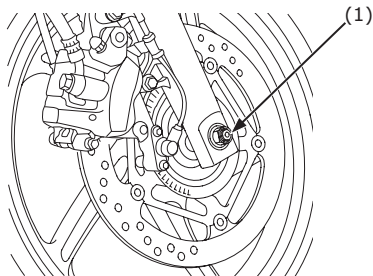

(1) Front Axle Nut

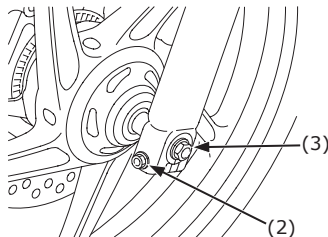

(2) Axle Pinch Bolt

(3) Front Axle Shaft

Avoid getting grease, oil, or dirt on the disc or pad surfaces. Any contamination can cause poor brake performance or rapid pad wear after reassembly.

Do not depress the brake lever when the wheel is off the vehicle. The caliper pistons will be forced out of the cylinders with subsequent loss of brake fluid. If this occurs, servicing of the brake system will be necessary. Visit your nearest Honda dealer for this service.

### **Front Wheel Installation**

1. Install the side collars into the left and right side wheel hub.
2. Position the wheel between the fork legs and insert the front axle shaft from the left side, through the right fork leg and wheel hub.

To avoid damaging the brake pads while installing the wheel, carefully fit the brake disc between the pads.

3. Tighten the front axle nut to the specified torque.

Front axle nut torque:

**59 N·m (6.0 kgf·m , 44 lbf·ft)**

4. Tighten the axle pinch bolt on the left fork leg to the specified torque.

Axle pinch bolt torque:

**22 N·m (2.2 kgf·m , 16 lbf·ft)**

5. After installing the wheel, apply the brake several times and then check if the wheel rotates freely. Recheck the wheel if the brake drags or if the wheel does not rotate freely.

If a torque wrench is not used for installation, visit your nearest Honda dealer as soon as possible to verify proper assembly. Improper assembly may reduce braking efficiency.

## Rear Wheel Removal

1. Support the vehicle securely, raise the rear wheel off the ground.
2. Loosen the "Drive Chain Lock Nut" (1) and "Drive Chain Adjusting Nut" (2).
3. Remove the "Rear Axle Nut" (3).
4. Remove the "Drive Chain" (4) from the driven sprocket by pushing the rear wheel forward.

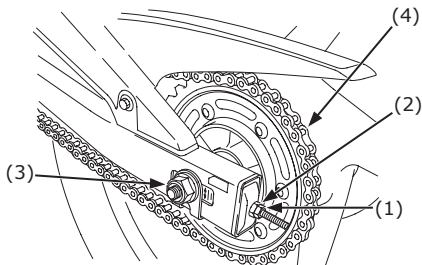

- (1) Drive Chain Lock Nut
- (2) Drive Chain Adjusting Nut
- (3) Rear Axle Nut
- (4) Drive Chain

5. Remove the "Rear Axle Shaft" (5), side collars and rear wheel from the swingarm.

Do not depress the brake pedal while the wheel is off the vehicle. The caliper piston will be forced out of the cylinder with subsequent loss of brake fluid. If this occurs, servicing of the brake system will be necessary. Visit your nearest Honda dealer for this service.

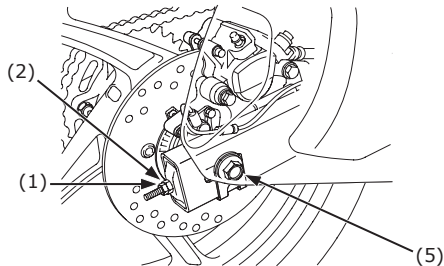

- (5) Rear Axle Shaft

## Rear Wheel Installation

To install the rear wheel, reverse the removal procedure.

1. Install the rear axle shaft, side collars and rear wheel to the swingarm.
  - Make sure that the "Lug" (1) on the "Brake Caliper Bracket" (2) is located in the "Slot" (3) in the "Swingarm" (4).

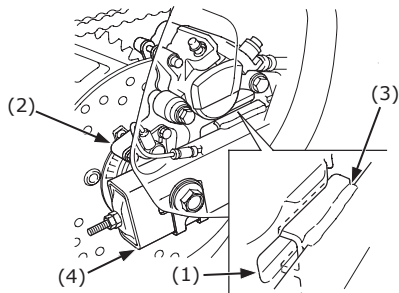

- (1) Lug
- (2) Brake Caliper Bracket
- (3) Slot
- (4) Swingarm

2. Install the drive chain over the driven sprocket.
3. Install the rear axle nut.
4. Adjust the drive chain (page 57).
5. Tighten the rear axle nut to the specified torque:

**88 N·m (9.0 kgf·m , 65 lbf·ft)**

When installing the wheel, carefully fit the brake disc between the brake pads to avoid damaging the pads.

After installing the wheel, apply the brake several times and then check if the wheel rotates freely. Recheck the wheel if the brake drags or if the wheel does not rotate freely.

If a torque wrench is not used for installation, visit your nearest Honda dealer as soon as possible to verify proper assembly. Improper assembly may reduce braking efficiency.

## BRAKE PAD WEAR

Refer to the Safety Precautions on page 45.

Brake pad wear depends upon the severity of usage, the type of riding, and road conditions. (Generally, the pads will wear faster on wet and dirty roads.)

Inspect the pads at each regular maintenance interval (page 48).

### Front Brake

#### (CBR250RJ)

Check the "Wear Indicator Grooves" (1) in each pad.

If either pad is worn to the bottom of the grooves, replace both pads as a set. visit your nearest Honda dealer for this service.

#### (CBR250RAJ)

Check the "Cutouts" (2) in each pad.

If either pad is worn to the cutout, replace both pads as a set. Visit your nearest Honda dealer for this service.

#### CBR250RJ

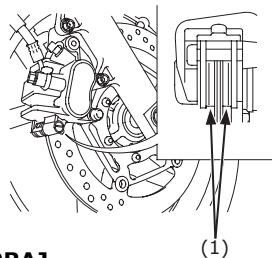

#### CBR250RAJ

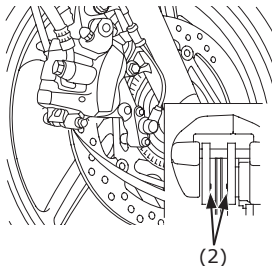

- (1) Wear Indicator Grooves
- (2) Cutouts

## Rear Brake

Check the "Wear Indicator Grooves" (1) in each pad.

If either pad is worn to the bottom of the grooves, replace both pads as a set. Visit your nearest Honda dealer for this service.

REAR BRAKE

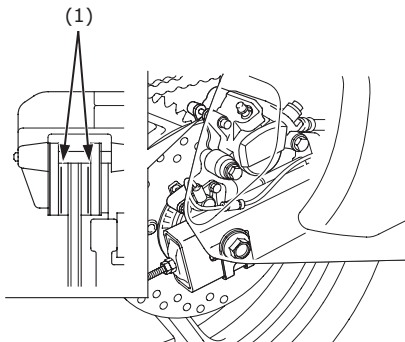

(1) Wear indicator grooves

## BATTERY

Refer to the Safety Precautions on page 45. It is not necessary to check the battery electrolyte level or add distilled water as the battery is a maintenance-free (sealed) type. If your battery seems weak and/or is leaking electrolyte (causing hard starting or other electrical troubles), contact your Honda dealer or battery manufacturer.

### NOTICE

*Your battery is a maintenance-free type and can be permanently damaged if the cap strip is removed.*



This symbol on the battery means that this product must not be treated as household waste.

### NOTICE

*Battery contains lead, which is a hazardous material and if improperly disposed, can be harmful to the environment and human health.*

Always return the used maintenance-free battery to the Honda dealer.



## **WARNING**

The battery gives off explosive hydrogen gas during normal operation.

A spark or flame can cause the battery to explode with enough force to kill or seriously hurt you.

Wear protective clothing and a face shield, or have a skilled mechanic do the battery maintenance.

### **Removal:**

"Battery" (1) is in the battery box under the front seat.

1. Make sure the ignition switch is OFF.
2. Remove the rear and front seats (pages 34-35).
3. Remove the "Battery Holder" (2) by removing the "Bolt" (3).
4. Disconnect the "Negative (-) Terminal Lead" (4) from the battery first, then disconnect the "Positive (+) Terminal Lead" (5).
5. Pull out the battery from the battery box.

### **Installation:**

1. Reinstall in the reverse order of removal. Be sure to connect the positive (+) terminal first, then the negative (-) terminal.
2. Check all bolts and other fasteners are secure.

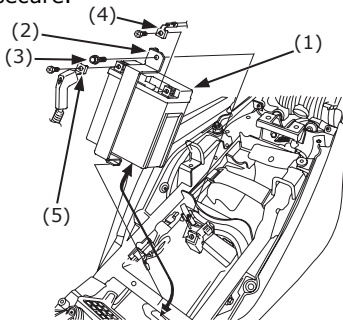

- (1) Battery
- (2) Battery Holder
- (3) Bolt
- (4) Negative (-) Terminal Lead
- (5) Positive (+) Terminal Lead

## FUSE REPLACEMENT

Refer to the Safety Precautions on page 45. When frequent fuse failure occurs, it usually indicates a short circuit or an overload in the electrical system. Visit your nearest Honda dealer for repair.

### NOTICE

*Never use a fuse with a different rating from that specified. Serious damage to the electrical system or a fire may result, causing a dangerous loss of lights or engine power.*

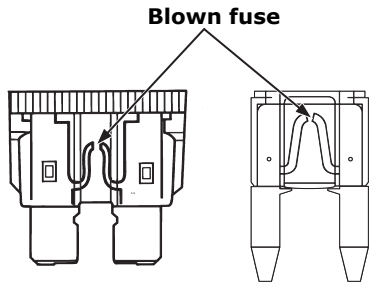

## Fuse Boxes: (CBR250RAJ)

The "Fuse Boxes" (1) are located under the seat. The specified fuses are:

10 A, 30 A

1. Remove the front seat (page 35).
2. Open the "Fuse Box Covers" (2).
3. Pull out the old fuse. If the fuse is blown, install a spare fuse.  
The "Spare Fuses" (3) are located in the fuse boxes.
4. Close the fuse box covers and install the seat.

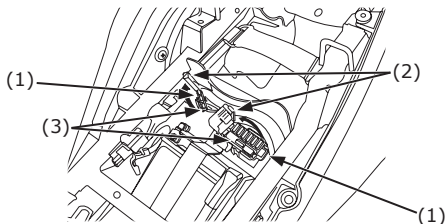

- (1) Fuse Boxes
- (2) Fuse Box Covers
- (3) Spare Fuses

## Fuse Box: (CBR250RJ)

The fuse box is located under the front seat. The specified fuses are: 10 A

1. Turn the ignition switch OFF before checking or replacing the fuses to prevent an accidental short-circuit.
2. Remove the rear and front seats (pages 34-35).
3. Open the "Fuse Box Cover" (1).
4. Pull out the old fuse and install a new fuse. The "Spare Fuse" (2) is located in the fuse box.
5. Close the fuse box cover and install the seats.

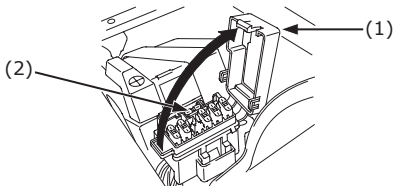

- (1) Fuse Box Cover  
(2) Spare Fuses

## Main Fuse:

The "Main Fuse" (1) is located on the starter magnetic switch near the battery.

The specified fuse is: 30 A

1. Turn the ignition switch OFF before checking or replacing the fuse to prevent an accidental short-circuit.
2. Remove the rear and front seats (pages 34-35).
3. Disconnect the "Wire Connector" (2) of the starter magnetic switch.
4. Pull out the old fuse and install a new fuse. The "Spare Main Fuse" (3) is attached to the battery cover.
5. Reconnect the connector.
6. Install the remaining parts in the reverse order of removal.

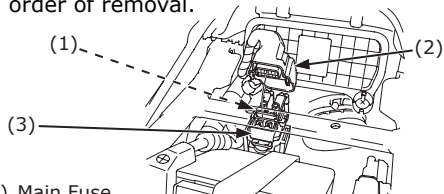

- (1) Main Fuse  
(2) Wire Connector  
(3) Spare Main Fuse

## BRAKELIGHT SWITCH ADJUSTMENT

Refer to the Safety Precautions on page 45.

Check the operation of the "Rear Brakelight Switch" (1) at the right side behind the engine from time to time.

Adjustment is done by turning the "Adjusting Nut" (2). Turn the nut in the direction (A) if the switch operates too late and in direction (B) if the switch operates too soon.

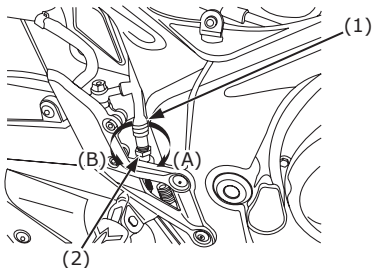

(1) Rear Brakelight Switch

(2) Adjusting Nut

## BULB REPLACEMENT

Refer to the Safety Precautions on page 45.

The light bulb becomes very hot while the light is ON, and remains hot for a while after it is turned OFF. Be sure to let it cool down before servicing.

Don't put finger on bulb, as they may create hot spots on the bulb and cause it to break.

Wear clean gloves while replacing the bulb. If you touch the bulb with your bare hands, clean it with a cloth moistened with alcohol to prevent its early failure.

- Be sure to turn the ignition switch OFF when replacing the bulb.
- Do not use bulbs other than those specified.
- After installing a new bulb, check that the light operates properly.

## Brake/Tail Light Bulb

1. Remove the rear seat (page 34).
2. Turn the "Socket" (1) counterclockwise, and remove it.
3. Slightly press the "Bulb" (2) and turn it counterclockwise.
4. Install a new bulb in the reverse order of removal.
5. Install the rear seat.

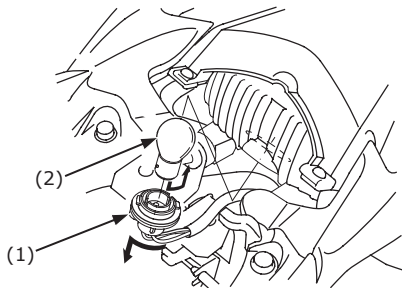

- (1) Socket  
(2) Bulb

## Front/Rear Turn Signal Bulb

The right and left turn signal bulbs replacement can be done in the same way.

1. Remove the "Turn Signal Lens" (1) and the "Lens Packing" (2) by removing the "Screw A" (3) and "Screw B" (4).
2. Slightly press the "Bulb" (5) and turn it counterclockwise.
3. Install a new bulb in the reverse order of removal.
  - Use only the amber bulb.

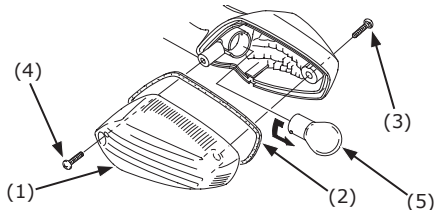

- (1) Turn Signal Lens  
(2) Lens Packing  
(3) Screw A  
(4) Screw B  
(5) Bulb

## License Light Bulb

1. Remove the "License Light Cover" (1) by removing the "Screws" (2).
2. Pull out the "Bulb" (3) without turning.
3. Install a new bulb in the reverse order of removal.

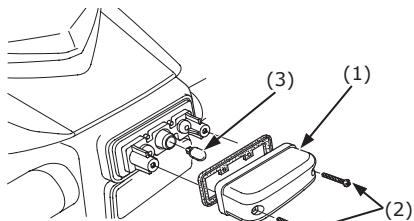



- (1) License Light Cover  
(2) Screws  
(3) Bulb

## LED Headlight

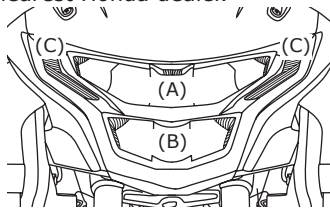
This vehicle is equipped with LED Headlight. If there is LED which is not turned ON, visit your nearest Honda dealer.



- (1) Position Light (C)  
(2) High Beam (B)  
(3) Low Beam (A)

Switch Position	Light	Glows
Ignition ON	Position Light & High or Low Beam	C & A or B
	High Beam 	A, B & C
	Low Beam 	A & C

## CLEANING

Clean your vehicle regularly to protect the surface finishes and inspect for damage, wear, and oil or brake fluid leakage.

Avoid cleaning products that are not specifically designed for vehicle or automobile surfaces.

They may contain harsh detergents or chemical solvents that could damage the metal, paint, and plastic on your vehicle.

If your vehicle is still warm from recent operation, give the engine and exhaust system time to cool off.

We recommend avoiding the use of high pressure water spray (typical in coin operated car washes).

### NOTICE

*High pressure water (or air) can damage certain parts of the vehicle.*

### Washing the vehicle

1. Rinse the vehicle thoroughly with cool water to remove loose dirt.
2. Clean the vehicle with a sponge or soft cloth using cool water.

Avoid directing water to muffler outlets and electrical parts.

3. Clean the plastic parts using a cloth or sponge dampened with a solution of mild detergent and water. Rub the soiled area gently rinsing it frequently with fresh water.

Take care to keep brake fluid or chemical solvents off the vehicle.

They will damage the plastic and painted surfaces.

The inside of the headlight lens may be clouded immediately after washing the vehicle. Moisture condensation inside the headlight lens will disappear gradually by lighting the headlight in high beam. Run the engine while keeping the headlight on.

4. After cleaning, rinse the vehicle thoroughly with plenty of clean water. Strong detergent residue can corrode alloy parts.
5. Dry the vehicle, start the engine, and let it run for several minutes.
6. Test the brakes before riding the vehicle. Several applications may be necessary to restore normal braking performance.

7. Lubricate the drive chain immediately after washing and drying the vehicle.

Braking efficiency may be temporarily impaired immediately after washing the vehicle.

Anticipate longer stopping distance to avoid a possible accident.

### **Finishing Touches**

After washing your vehicle, consider using a commercially-available spray cleaner/polish or quality liquid or paste wax to finish the job. Use only a nonabrasive polish or wax made specifically for vehicles or automobiles. Apply the polish or wax according to the instructions on the container.

If a surface on your vehicle is chipped or scratched, your Honda dealer has touchup paint to match your vehicle's color. Be sure to use your vehicle's color code (page 49) when you buy touch-up paint.

### **Removing Road Salt**

The salt contained in the road surface freezing prevention medicine which a road was sprayed with in winter, and the seawater becomes the cause which rust occurs in.

Wash your vehicle by the following point after it runs through such a place.

1. Clean the vehicle using cool water (page 73).

Do not use warm water.

This worsens the effect of the salt.

2. Dry the vehicle and the surface of the metal is protected with the wax.

## **STORAGE GUIDE**

Extended storage, such as for winter, requires that you take certain steps to reduce the effects of deterioration from Non-use of the vehicle. In addition, necessary repairs should be made before storing the vehicle; otherwise, these repairs may be forgotten by the time the vehicle is removed from storage.

### **STORAGE**

1. Change the engine oil.
2. Make sure the cooling system is filled with a HONDA PRE-MIX COOLANT.
3. Empty the fuel tank into an approved petrol container using a commercially available hand siphon or an equivalent method. Spray the inside of the tank with an aerosol rust-inhibiting oil. Reinstall the fuel fill cap on the tank.



## **WARNING**

Petrol is highly flammable and explosive. You can be burned or seriously injured when handling fuel.

- Stop the engine and keep heat, sparks, and flame away.
- Refuel only outdoors.
- Wipe up spills immediately.

4. To prevent rusting in the cylinder, perform the following:
  - Remove the spark plug cap from the spark plug. Using tape or string, secure the cap to any convenient plastic body part so that it is positioned away from the spark plug.
  - Remove the spark plug from the engine and store it in a safe place. Do not connect the spark plug to the spark plug cap.
  - Pour a table spoon (15-20 cm<sup>3</sup>) of clean engine oil into the cylinder and cover the spark plug hole with a piece of cloth.
  - Crank the engine several times to distribute the oil.
  - Reinstall the spark plug and spark plug cap.

5. Remove the battery. Store in an area protected from freezing temperatures and direct sunlight.
6. Wash and dry the vehicle. Wax all painted surfaces. Coat chrome with rust inhibiting oil.
7. Lubricate the drive chain (page 59).
8. Inflate the tyres to their recommended pressures. Place the vehicle on blocks to raise both tyres off the ground.
9. Cover the vehicle (don't use plastic or other coated materials) and store in an unheated area, free of dampness with a minimum of daily temperature variation. Do not store the vehicle in direct sunlight.

### **REMOVAL FROM STORAGE**

1. Uncover and clean the vehicle.
2. Change the engine oil if more than 4 months have passed since the start of storage.
3. Drain any excess aerosol rust-inhibiting oil from the fuel tank. Fill the fuel tank with fresh petrol.
4. Perform all Pre-ride Inspection checks (page 38).

Test ride the vehicle at low speeds in a safe riding area away from traffic.

# SPECIFICATIONS

## DIMENSIONS

Overall length -----	2,030mm (79.9 in)
Overall width -----	720 mm (28.3 in)
Overall height -----	1,127 mm (44.4 in)
Wheel base -----	1,369 mm (53.9 in)

## WEIGHT

Dry weight -----	156 kg (344 lbs)
------------------	------------------

## CAPACITIES

Engine oil	After draining -----	1.4 L (1.5 US qt, 1.2 Imp qt)
	After draining & oil filter change -	1.5 L (1.6 US qt, 1.3 Imp qt)
	After disassembly -----	1.8 L (1.9 US qt, 1.6 Imp qt)
Fuel tank -----	13.0 L (3.43 US gal, 2.86 Imp gal)	
Cooling system capacity	Full -----	1.1 L (1.2 US qt, 1.0 Imp qt)
	Exchange -----	0.79 L (0.83 US qt, 0.81 Imp qt)
Passenger capacity -----	Rider and one pillion rider	
Maximum weight capacity -----	180 Kg (397 lbs)	

## ENGINE

Bore and stroke -----	76.0 x 55.0 mm (2.99 x 2.17 in)	
Compression ratio -----	10.7:1	
Displacement -----	249.6 cm <sup>3</sup> (15.23 CU-in)	
Spark plug -----	NGK SIMR8A9	
Spark plug gap -----	0.8-0.9 mm (0.031-0.035 in)	
Idle speed -----	1,400 ± 100 min <sup>-1</sup> (rpm)	
Valve clearance (Cold)	Intake -----	0.16 ± 0.02 mm (0.006 in)
	Exhaust -----	0.27 ± 0.02 mm (0.011 in)

## CHASSIS AND SUSPENSION

Caster -----	25°
Trail -----	95 mm (3.7 in)
Tyre size, front -----	110/70 - 17M/C 54S
Tyre size, rear -----	140/70 - 17M/C 66S
Suspension	
Front -----	Telescopic Fork
Rear -----	Pro-link
Turning radius -----	2.64 m

## FUEL SYSTEM

Type -----	Fi (Fuel Injection)
------------	---------------------

## POWER TRANSMISSION

Primary reduction -----	2.808
Gear ratio,	
1st -----	3.333
2nd -----	2.117
3rd -----	1.571
4th -----	1.304
5th -----	1.115
6th -----	0.962
Final reduction -----	2.714

## ELECTRICAL

Battery -----	12V-6Ah/ MF - Maintenance Free
Generator -----	0.29 kW/5,000 min <sup>-1</sup> (rpm)

## COOLING SYSTEM

Engine cooling system	Liquid
Radiator Type	Fin Type
Thermostat Temp./Max Lift	82°C/3.6mm
Cooling fan drive temp.	98°C
Water Pump Type	Centrifugal

## LIGHTS

Head light	LED
Tail light	5W
Stop light	21W
License plate lamp	5W
Turn signal light	
Front	21Wx2
Rear	21Wx2
Position light	LED
Speedometer lights	LED
Tachometer lamp	LED
Neutral indicator	1.7 W
Turn signal indicator	LED
High beam indicator	LED
Temp. indicator	LED

## FUSE

Main fuse	30A
Other fuse	10A

## Warranty Policy

Honda Motorcycle & Scooter India (Pvt.) Ltd. (HMSI) gives the following warranty in respect of “**CBR 250R**” manufactured by them.

Proper care and precaution has been taken to ensure the best quality in respect of the material and workmanship in manufacturing “**CBR 250R**”.

HMSI will replace or repair at their authorised workshops, free of charge, within a period of 24 months from the date of sale or until the vehicle has been driven for 32,000 kms. of run, whichever event occurs first, such part or parts thereof as may be found, on examination, to have manufacturing defect.

Warranty claims in respect of proprietary parts like tyres and battery are warranted by their respective manufacturers and should be claimed on them directly by customer.

**NOTE:** Battery Warranty is applicable from 21 months from Date Of Charging at manufacturer or 18 Months from the Date Of Sale or 20000 Kms whichever is earlier.

In all such cases the decision of the respective manufacturer will be final and binding.

HMSI shall not be liable in any manner to replace them though their dealers will give full assistance in preferring such claims on their manufacturers.

HMSI undertake no liability in the matter of consequential loss or damage caused due to the failure of the parts. Delay, if any, at the repairing workshop in carrying out repair to vehicle shall not be a ground for extending the warranty period nor shall it give any right to the customer for claiming any compensation for damages.

HMSI reserves the right either to repair or replace the defective part.

Where a defective part can be replaced by part/s of alternative brand/s, which are normally used by HMSI in the course of manufacturing, HMSI reserves the right to carry out the replacement by a part or parts of any such alternative brands.

**Valid in India only**

This warranty and any claim arising there from is subject to Gurgaon jurisdiction only.

No claim for exchange or repair can be consider unless the customer:

- a. Ensures that immediately upon discovery of the defect, he approaches any nearest authorised dealer of HMSI with the concerned vehicle and enables him to remove and dispatch the part/parts attributing to manufacturing defect to the company.
- b. Produces Owner's Manual in original, to enable that dealer to verify the details. It must be expressly understood that claims forwarded directly to us by the wner/customer will not be entertained at all and such defective part/parts thus forwarded by them will lie at our factory at their own risk, and this warranty shall not be enforceable.

Further this warranty is not applicable to:

1. Any **"CBR 250R"** on which any free and paid services has not been carried out, as per schedule given in Owner's Manual.
2. Normal maintenance operations like valve adjustment, cleaning of fuel system, engine tune-up or such other adjustments.
3. HMSI does not warrant normal wear and tear items like Brake Pad, Brake Disc ,Clutch Disc, Chain, Chain Sprocket, Wheel Rim (in case of misalignment and bent), Bushes, Fasteners, Shims, Washers and Electrical Items like Bulbs, Rubber and Plastic Components like Grommets, O-Rings,Bellows as well as Packings, Gaskets, Oil Seals and Consumables like Fuel Filter, Oil Filter Element, Air Cleaner Element, Engine Oil, Grease, Brake Fluid, Suspension Oil,Coolant and other items as specified by HMSI.
4. Fasteners and clips which needs replacement during maintenance/service will not be covered under warranty.
5. If there is any damage to the painted surface due to industrial pollution or other extraneous factors.
6. Any damage resulting from unavoidable natural disaster i.e fire collision, earthquake, flood etc.
7. Any damage caused by exposure of the product to soot and smoke, chemical agents, bird-droppings, sea water, sea breeze, or other environmental phenomenon.
8. If there is any damage caused due to usage of improper oil/grease, non genuine parts.

9. No warranty will be applicable in case of damage to Engine or Cooling system due to non-usage of Honda Pre-Mixed Coolant or due to usage of water or Non- Recommended coolant.
10. For two-wheelers, which have been used for any commercial purposes as taxi etc.
11. For maintenance repairs required due to misuse while driving or due to adulteration of oil, petrol or due to bad road conditions.
12. Recommended fuel quality not used.
13. Parts of the vehicle that have been subjected to misuse, accident, negligent treatment or which have been used in conjunction with parts and an equipment not manufactured or recommended for use by HMSI if in the sole judgment of HMSI, such use prematurely affects the performance and reliability of the vehicle.
14. Parts of the vehicle that have been altered or modified or replaced in unauthorised manner, and which in the sole judgment of HMSI affect its performance and reliability.
15. The vehicle that has not been serviced by HMSI authorised dealer as per the service schedule or which have not been operated or maintained in accordance with instructions mentioned in the Owner's Manual.
16. The vehicles used for any competition or race and/or for attempting to set up any kind of record HMSI reserves the right to make any changes in design or to add any improvement on the vehicle at any time without incurring any obligations to install the same on a vehicle previously supplied and sold. Also the conditions of this warranty are subject to alteration without any notice.

This warranty is entirely written warranty given by HMSI for "**CBR 250R**" and no other person, including the dealer or its or his agent or employee is authorised to extend or enlarge this warranty.

This warranty is given in lieu of and excludes every condition or warranty whether statutory or otherwise not herein expressly set out.

### **EMISSION WARRANTY**

Subject to other terms of the warranty policy and other conditions and obligations laid down hereunder, the manufacturer certifies that the components liable to affect the emission of the gaseous pollutants in the vehicle in normal use despite the use to which it may be subjected, comply with provisions of rule 115(2) of the Central Motor Vehicle Rules, 1989 and further warrants that if on examination by a service

Valid in India only

center duly authorized by the manufacturer, the vehicle is discovered to be failing to meet the emission standard as specified in the said rule, the authorized service center shall take such corrective measures as may be necessary and shall at its sole discretion replace free of charge such components of emission control system as are specified in schedule.

#### A. Conditions

1. This warranty will be in addition to and run parallel to the product warranty given by the manufacturer and will apply to components as mentioned later. This warranty is applicable in Delhi, Mumbai, Kolkata and Chennai with effective from 1st July 2001. Other places when included will be covered under warranty accordingly.
2. The period of the vehicle's emission warranty will be determined starting from the date of the vehicle sale. The period of time and kilometers that are covered under the provisions of warranty may vary but should not be less than the minimum warranty period based on the vehicle category.

**For a two-wheeler the emission warranty period is 30,000 kms or 3 years whichever is earlier.**

3. Warranty claim for the components under Emission warranty will be admitted, for a prima facie examination, in the event of failure of the vehicle to meet the emission standard as specified in sub-rule (2) of Rule No 115 of the Central Motor vehicle Rules.
4. The warranty claim will be accepted only after the examinations carried out by Authorized Service Centers leads to a firm conclusion that none of the original settings have been tampered with and that the components has/have a manufacturing defect, and/or, that the vehicle is unable to meet the in-use emission standard, in spite of the vehicle being maintained and used in accordance with the instructions in the owner's manual.
5. The methods of examination to determine the warrantable condition of the components will be at the sole discretion of manufacturers and or their Authorized service centers and results of such examination will be final and binding. If, on examination, a warrantable condition is not established, the manufacturers will have to charge all, or part, of the cost of such examination.
6. In case of a vehicle in which the components covered under Emission warranty, the



manufacturer will replace, at Authorized centers free of charge, the components which are covered, but the consumables as mentioned in Owner's Manual shall be charged as per actuals.

7. In case of a vehicle in which the components covered under Emission warranty or the associated parts are not independently replaceable on account of their being integral parts of a complete assembly, the manufacturer will have the sole discretion to replace either the entire assembly or by using some of the parts of the system through suitable repairs or modifications.
8. Any consequential repairs or replacement of parts which may be found necessary to establish compliance to in-use emission standards, in addition to replacement of the parts covered under emission warranty, will not be made free of cost unless such parts are also found to be in a warrantable condition within the scope and limit of the product warranty. The consumables shall be charged as per actuals during such repairs or replacement of parts.
9. All the parts removed for replacement under warranty will be the property of the manufacturer.
10. The manufacturer will not be responsible for the cost of transportation of the vehicle to the nearest Authorized Service center or any loss due to non-availability of the vehicle during the period of lodging of a warranty claim and examination by the manufacturer and repairs.
11. The manufacturer will not be responsible for any penalties that may be charged by statutory authorities on account of failure to comply with the in use emission standards.
12. Emission warranty will be applicable irrespective of the change of ownership of the vehicle provided all the conditions as laid down in this document are met from the date of original sale of the vehicle.
13. The emission warranty will be applicable only if:
  - a. Observes all the important instructions and any other precautions listed in the Owner's Manual for use of the vehicle.
  - b. Under all circumstances uses lubricants and fuel as recommended by manufacturer.
  - c. Regularly obtains and carries out maintenance in accordance with the manufacturers guidelines and enters the details in the Logbook.

**Valid in India only**

- d. Immediately approaches the nearest authorized service center upon discovery of failure to comply with the in use emission standards in spite of having maintained and used the vehicle in accordance with the instructions in the Owner's Manual and having carried out such repairs and adjustments as may be required with a view to establish such compliance.
  - e. Produces the 'Pollution Under Control' certificate valid for the period immediately preceding the test during which the failure is discovered, the test having been carried out either for obtaining a new certificate, or pursuant upon being directed by an officer as referred to in sub-rule(2) of Rule 116 of the Central Motor Vehicle Rules.
  - f. Produces the Owner's Manual and Log book for verification details.
  - g. Produces receipts covering maintenance of the vehicle as specified in the Owner's Manual from the date of original purchase of the vehicle.
  - h. Produces valid certificate of insurance and RTO registration.
14. Conditions under which warranty is not applicable:

A valid 'Pollution Under Control' certificate as described in customer obligation D(6) above is not produced.

A vehicle which is not serviced by Authorized service center as per the service schedule described in the maintenance chart given in the Owner's Manual.

A vehicle, which has been subjected to abnormal use, abuse, neglect and improper maintenance or has met with an accident. Use of replacement parts not specified and approved by the manufacturer.

A vehicle, or parts thereof, which has been altered, tampered with or modified or replaced in an unauthorized manner.

A vehicle on which the odometer is not functioning or the odometer has been changed/tampered with so that the actual mileage cannot be readily determined.

A vehicle which has been used for competitions, races, rallies or for the purpose of establishing records

Examination by the manufacturers or his Authorized Service Centers of the vehicle shows that any of the conditions stipulated in the Owner's Manual with regard to use and maintenance have been violated.

A vehicle, which has been run on, adulterated fuel, leaded fuel or lubricant or fuel/lubricants other than those specified by the manufacturer in the Owner's Manual with regard to use and maintenance have been violated.

### SCOPE AND LIMITS

1. This emission warranty is in addition to product warranty and shall run parallel to the product warranty for the vehicle as per the scope and limit described in the Owner's Manual and all conditions described there in will apply in addition to those exclusively stipulated in this warranty.
2. The emission warranty covers only compliance with the emission standard as specified in the sub rule (2) of rule 115 of CMVR. It does not cover any other performance of these parts or routine test and consequent maintenance

or adjustments to establish compliance to the in use emission standard as applicable to the state, in which the vehicle is registered and is in use.

The parts which are covered under emission warranty are Injector, PGM-FI unit, Pump unit fuel, Ignition coil, Muffler and Canister comp. etc.

**NOTE:**The emission warranty is applicable only when a customer enters into emission warranty contract.