

KP2SC Self-Contained Compactor

INCLUDES INFORMATION FOR THE FOLLOWING MODELS:

- KP2SC20
- KP2SC25
- KP2SC30
- KP2SC35
- KP2SCL20
- KP2SCL30

TABLE OF CONTENTS

FOREWORD

PURPOSE OF MANUAL	1
SCOPE	1
ABOUT K-PAC™	1
CORPORATE HEADQUARTERS	1
DEALER SUPPORT	2

GENERAL

IDENTIFICATION PLATE	5
FEATURES	6
SPECIFICATIONS	6
KP2SC SPECIFICATIONS	6
STANDARD POWER PACK	6
CYCLE TIME	6
DIMENSIONS	7
STANDARD POWER PACK	7

SAFETY

IMPORTANT SAFETY INFORMATION	9
SAFETY ALERT SYMBOL	9
SAFETY ALERTS	10
SAFETY DECAL REQUIREMENTS	11
COMPACTOR SAFETY DECALS	11
SAFETY DECAL LOCATIONS	12
Left Side	12
Chamber and Tailgate	12
Right Side	13
SAFETY DECAL IDENTIFICATION	14
POWER PACK SAFETY DECALS	15
SAFETY DECAL LOCATIONS	15
Power Pack	15
SAFETY DECAL IDENTIFICATION	16
LOCKOUT/TAGOUT	17
LOCKOUT/TAGOUT PROCEDURE	17
REMOVE LOCKOUT/TAGOUT	20
PROCEDURES FOR WORK IN CONFINED SPACES	20
HIGH VOLTAGE SAFETY	20
DEFINITIONS	21
ARC FLASH	21
PROCEDURES FOR ELECTRICAL ARC FLASH AND SHOCK SAFETY	21
MOST COMMON HAND SIGNALS USED IN THE FIELD	22

INSTALLATION

INSTALLATION REQUIREMENTS	23
GENERAL	23
MAIN POWER DISCONNECT	23
INSTALLATION INSTRUCTIONS	23
INSTALLATION SITE	23
ELECTRICAL INSTALLATION	26
MAIN POWER DISCONNECT	27
WIRE COLORS	28
WIRING CONNECTIONS	29

TABLE OF CONTENTS

OPERATION

CONTROL PANEL and REMOTE CONTROL	31
OPERATING INSTRUCTIONS FOR STANDARD COMPACTORS	32
AUTO MODE	32
MANUAL MODE	32
CONTAINER FULL LIGHTS	32

START-UP AND TESTING INSTRUCTIONS

POWER PACK START-UP	33
HYDRAULIC HOSE INSTALLATION	35
MANUAL MODE - RAM CYLINDER CYCLING	36
AUTO MODE - RAM CYLINDER CYCLING	36
VALIDATE INTERLOCKS	36

MAINTENANCE

MAINTENANCE INSTRUCTIONS	37
PREVENTIVE MAINTENANCE	38
INITIAL CHECK	38
AFTER EMPTYING	38
MONTHLY CHECK	38
3-MONTH CHECK	38
MAINTENANCE INSTRUCTIONS FOR TAILGATE SEALS	38
FILTER MAINTENANCE	38
YEARLY CHECK	39
HYDRAULIC HOSE MAINTENANCE	39
LUBRICATION	40
RECOMMENDED HYDRAULIC FLUID	41
GENERAL MAINTENANCE TIPS	42
OIL	42
FILTERS	42
RELIEF VALVES	42
PUMP	42
HEAT	42

SERVICE

PLC PROGRAMMING PROCEDURE	43
TIMER AND CYCLE SETTINGS	46
MAIN RELIEF ADJUSTMENT	50
PRESSURE SWITCH ADJUSTMENT	51
CYLINDER PIVOT PIN INSPECTION	52

SCHEMATICS

CONTROL PANEL VOLTAGE OPTIONS	53
CONTROL TRANSFORMER WIRING	53
POWER PACK ELECTRICAL SCHEMATIC	54
208, 230, 460 VAC, 10HP, 3 PHASE, 60 HERTZ	54
ELECTRICAL SCHEMATIC SECTIONS	55
Section "A"	55
Section "B"	55
Section "C"	56
Section "C"	56
HYDRAULIC SCHEMATIC	57
10HP, 3 PHASE, 60-HERTZ	57

TABLE OF CONTENTS

PARTS

OVERVIEW	59
CONTAINER	60
Door and Hinges Illustration	60
Door and Hinges Parts List	61
Door Latch Linkage Illustration	62
Door Latch Linkage Parts List	63
CHAMBER	64
Cover Plate, Rollers and Ram Blocks Illustration	64
Cover Plate, Rollers and Ram Blocks Parts List	65
Ram and Follower Assembly Illustration	66
Ram and Follower Assembly Parts List	67
Ram Cylinders and Mounting Illustration	68
Ram Cylinders and Mounting Parts List	69
Ram Cylinder Hydraulics Illustration	70
Ram Cylinder Hydraulics Parts List	71
CONTROL PANEL	72
Panel Cover Illustration	72
Panel Cover Parts List	73
Inside Panel Illustration	74
Inside Panel Parts List	75
POWER PACK	76
Assembly Illustration	76
Assembly Parts List	77
Hydraulic Reservoir Illustration	78
Hydraulic Reservoir Parts List	79
Pump Hydraulics Illustration	80
Pump Hydraulics Parts List	81
Motor and Pump Illustration	82
Motor and Pump Parts List	83

TABLE OF CONTENTS

This Page Intentionally Left Blank

FOREWORD

PURPOSE OF MANUAL

You have purchased a quality designed and manufactured K-PAC™ compactor. Advanced features have been designed into the compactor for modern disposal operations. As with any investment, a return is expected and the return received from this investment will be in the form of maximum performance during many years of dependable service.

In order to maintain quality performance of the new K-PAC™ compactor, it is important that all of the information in the manual be reviewed and studied carefully before operation.

It is suggested that owner/users read ANSI National Standards Z245.2-2013 for stationary compactors. Copies may be purchased from the American National Standards Institute, 11 W. 42nd Street, New York, NY, 10036, Phone: 212-642-4900.

SCOPE

This manual provides information for use by the owner/user. This manual contains a variety of information for General, Safety, Installation, Operation, Start-Up, Maintenance, Service, Schematics and Parts.

ABOUT K-PAC™

K-PAC™ Equipment, a division of New Way® has established itself as a leader in innovation and dependability in the waste equipment industry. From engineering to production, K-PAC™ is committed to providing top quality equipment and service. K-PAC™'s neat, clean appearance, in both the rear and front loading model, blends attractively with its surroundings.

In 2008 New Way® acquired K-PAC™ Equipment, a leader in solid waste compaction equipment. New Way® now offers two lines of K-PAC™ Industrial & Commercial Compactors: stationary compactors and self-contained compactors. There is a K-PAC™ model to fit nearly every commercial and industrial application. From solid waste to heavy industrial waste compactors, K-PAC™ compactors will crush nearly anything you throw their way.

CORPORATE HEADQUARTERS

Contact New Way® Trucks for K-PAC™ factory direct sales and product support.

New Way® TRUCKS

P.O. Box 336
101 State Street
Scranton, IA 51462

TELEPHONE

Direct: 712-652-3396
Sales: 800-831-1858
Parts and Service: 844-652-3395

WEBSITE

www.kpac-wastecompaction.com

FOREWORD

DEALER SUPPORT

K-PAC™ is committed to the design and manufacture of the best compactors, but it is our dealers that bring it all together for you. K-PAC™ boasts a large, dedicated dealer network throughout the United States as well as internationally. We understand and appreciate the value that our dealers provide to us and to end users. Our dealers are our most important partner in helping you to install, support and maintain your compactor.

The following is a list of K-PAC™ dealers that can support your needs:

CALIFORNIA

EDCO Waste & Recycling Services
Lemon Grove (San Diego), CA 91945
OFC: 619-287-5696, x4104

Gold Coast Ecology
Simi Valley, CA 93063-6425
OFC: 805-501-5659

COLORADO

Elliott Equipment
Commerce City, CO 80022
OFC: 303-853-4840

ILLINOIS

Elliott Equipment
OFC: 563-391-4840 - Davenport
OFC: 563-391-4840 - Grimes (Corporate)

Rantoul Truck Center
Rantoul, IL 61866
OFC: 217-893-4158 Toll Free: 877-898-9900

INDIANA

Municipal Equipment
Toll Free: 800-248-7590

IOWA

Elliott Equipment
OFC: 563-391-4840 - Davenport
OFC: 563-391-4840 - Grimes (Corporate)

KANSAS

Elliott Equipment
OFC: 816-761-4840

KENTUCKY

Municipal Equipment
OFC: 800-248-7590

MINNESOTA

Olympic Sales
Greg Krutsinger
OFC: 701-281-8221

FOREWORD

MISSOURI

Elliott Equipment
Grandview, MO 64030
OFC: 816-761-4840

NEBRASKA

Elliott Equipment
Lincoln, NE 68521
OFC: 402-474-4840

NEW YORK

Long Island Sanitation, LLC
1670 New Highway
Farmingdale, NY 11735
OFC: 631-531-9292

VIRGINIA

Municipal Equipment
OFC: 800-248-7590

WASHINGTON

GK Industrial Refuse Systems
Auburn, WA 98002
OFC: 800-295-5543

WYOMING

Elliott Equipment
OFC: 563-391-4840 - Davenport
OFC: 563-391-4840 - Grimes

FOREWORD

This Page Intentionally Left Blank

GENERAL

IDENTIFICATION PLATE

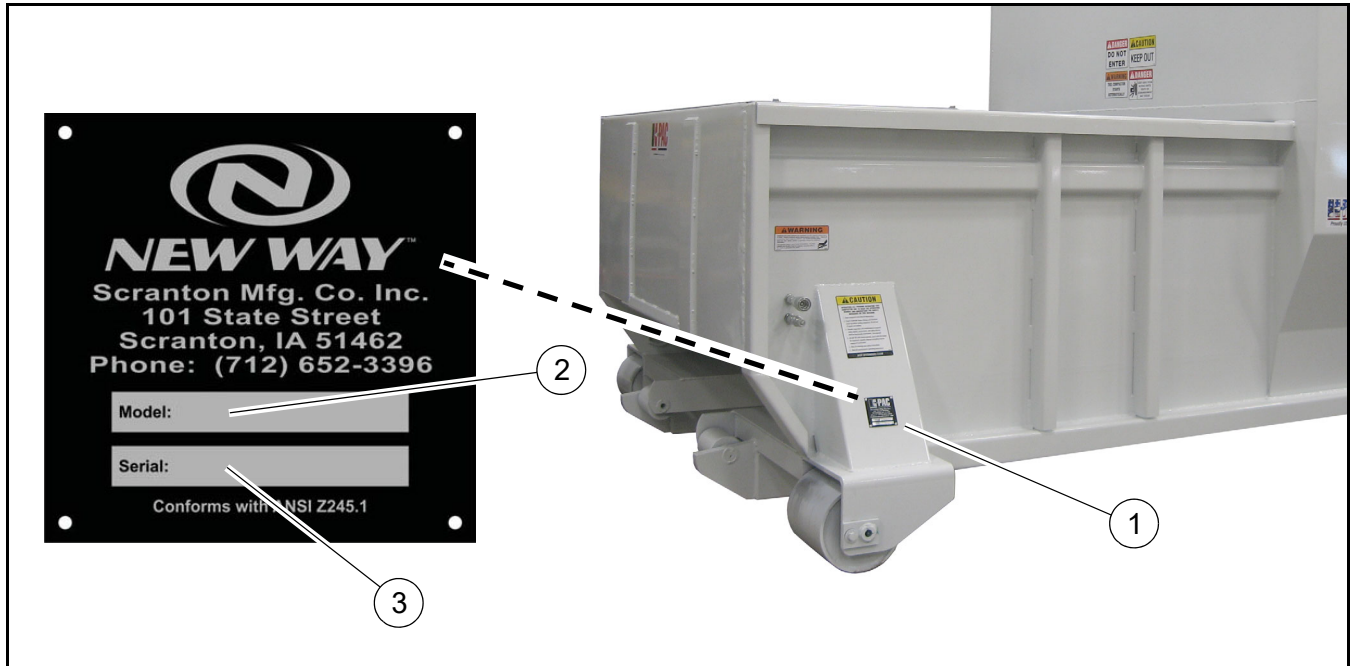

Figure 1

An identification plate (**Figure 1, 1**) is located at the left-front corner of the chamber.

The identification plate contains the compactor model number (**Figure 1, 2**). The model number for compactors covered by this manual will have the format KP2SC-XX-Yd. The first part of the model number, KP2SC, is the code which represents the model. Code KP2SC represents a self-contained compactor with a 2 cubic yard charge chamber and a side opening door. The code is followed by a dash number that represents the container capacity. Capacity sizes of 20, 25, 30 and 35 Cu Yd are available. A low profile charge chamber option is available for 20 and 30 Cu Yd capacities.

A specific serial number (**Figure 1, 3**) is assigned to each compactor when it is manufactured. This serial number is important and should be used when requesting service or ordering parts. The serial number for compactors covered by this manual will have the format K1716-XX-XX. The first part of the serial number, K1716, represents the sales order number for the compactor. The next -XX represents the month the compactor was manufactured. The last -XX represents the year the compactor was manufactured.

GENERAL

FEATURES

- Clear charge chamber opening of 41" x 68" is the largest in industry to prevent "bridging."
- Full 14" ram penetration out performs competitive models.
- 46.5" feed height eases ground level loading.
- Guided and supported ram with easily replaceable guide shoes increases structural life and reduces maintenance costs.
- "NoShok" system eliminates limit switches (80% of service calls) and improves hydraulic life.
- .38" High Strength hopper floor is 52% thicker and 300% stronger than competitive guided ram compactors.
- Wider ground rollers improve pavement life over competition.
- Epoxy based paint with UV inhibitors exceed industry standards.
- Adjustable door hinges and strongest structural design insure door rigidity to provide liquid integrity.
- Full door seal of closed cell neoprene (as used in nuclear submarines) provides superior sealing and outlasts competitive seals.
- Self-cleaning compactor sump (sub-floor) to prevent debris buildup behind ram.

SPECIFICATIONS

KP2SC SPECIFICATIONS

• Ram Face	53"W x 46"H
• Clear Top Opening	41" x 68"
• Loading Height	46.5"
• Ram Penetration	14"
• Packing Force Normal	42,250 lbs.
• Packing Force Max.	45,700 lbs.
• Packing Pressure Normal	1,850 PSI
• Packing Pressure Maximum	2,100 PSI
• Hopper Floor	.38 A36 Plate
• Compactor Sides	.25 Plate
• Ram Top	.38 Plate
• Ram Face	.25 Plate

STANDARD POWER PACK

• Power Pack	10 HP / 3 Phase 208/230/460 Volt 60 Hertz
• Hydraulic Pump	12 GPM
• Reservoir	20 Gallons
• Cylinders	2 - 4" x 37" Diagonal

CYCLE TIME

• Time	34 Seconds
--------	------------

GENERAL

DIMENSIONS

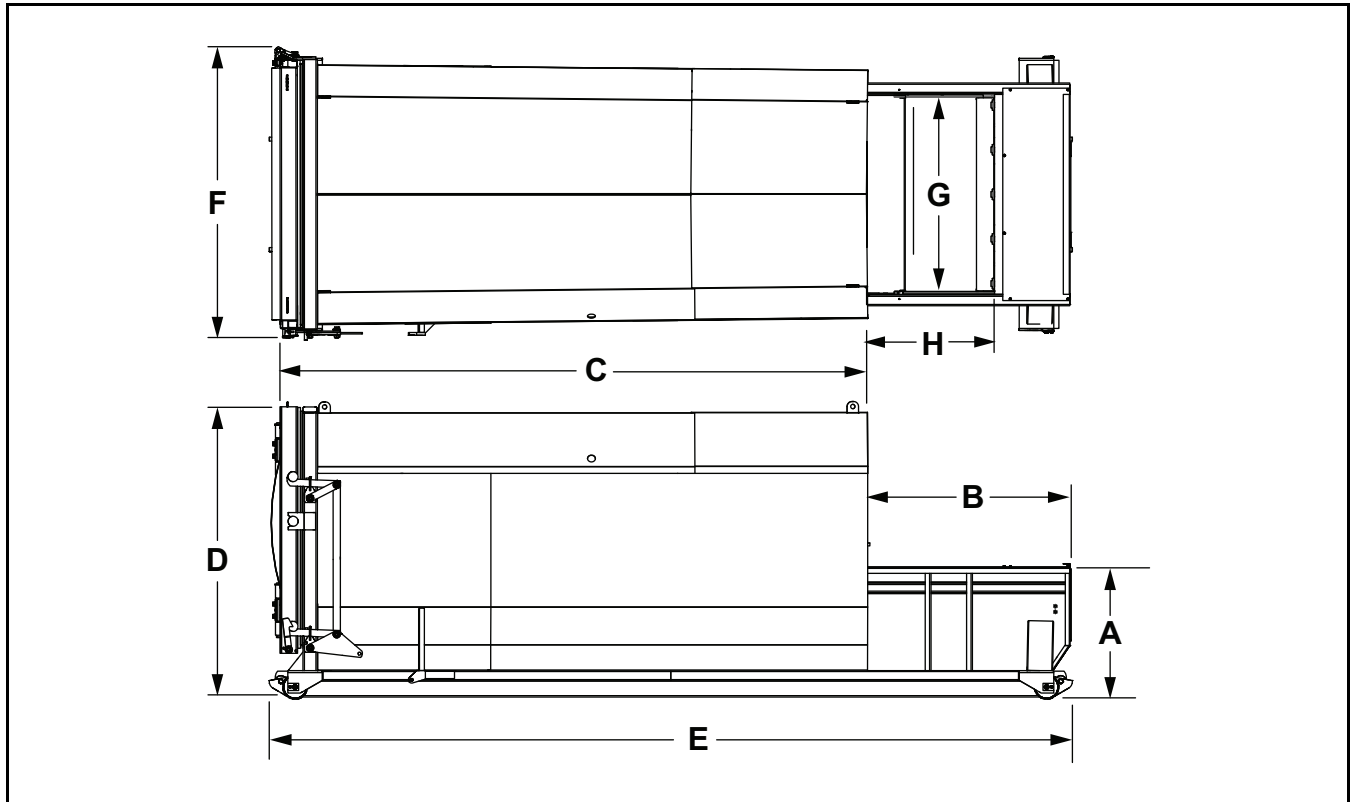

	MODEL	KP2SC20	KP2SC25	KP2SC30	KP2SC35	KP2SC20-LP	KP2SC30-LP
	Total Capacity - (Cu Yd)	20	25	30	35	20	30
A	Chamber Height (Inches)	46.5	46.5	46.5	46.5	46.5	46.5
B	Chamber Length (Inches)	71.5	71.5	71.5	71.5	71.5	71.5
C	Body Length (Inches)	117	147	177	207	135	207
D	Overall Height (Inches)	102	102	102	102	90	90
E	Overall Length (Inches)	188	219	249	279	207	279
F	Tailgate Width (Inches)	101.5	101.5	101.5	101.5	101.5	101.5
G	Chamber Width (Inches)	68	68	68	68	68	68
H	Chamber Opening (Inches)	41	41	41	41	41	41
	Weight	9300	9835	10370	10900	9030	10100

STANDARD POWER PACK

- Motor - 10HP 208 / 230 / 460 3-Phase 60 Cycle
- Control Voltage - 115 VAC
- Key operated Start/Stop/Reverse

GENERAL

This Page Intentionally Left Blank

SAFETY

IMPORTANT SAFETY INFORMATION

READ AND UNDERSTAND THIS ENTIRE MANUAL BEFORE OPERATING, REPAIRING OR ADJUSTING YOUR K-PAC™ COMPACTOR.

THOSE WHO USE AND MAINTAIN THIS EQUIPMENT MUST BE THOROUGHLY TRAINED AND FAMILIAR WITH THE PRODUCT.

 <b style="font-size: 1.2em; margin-left: 10px;">WARNING	<p>IF INCORRECTLY USED, THIS EQUIPMENT CAN CAUSE SEVERE INJURY. THOSE WHO USE AND MAINTAIN THE EQUIPMENT SHOULD BE TRAINED IN ITS PROPER USE, WARNED OF ITS DANGERS AND SHOULD READ AND FULLY UNDERSTAND THIS ENTIRE MANUAL BEFORE ATTEMPTING TO SET UP, OPERATE, ADJUST OR SERVICE THE EQUIPMENT. KEEP THIS MANUAL FOR FUTURE REFERENCE.</p>
---	--

Should operators of this equipment have a reading or learning disability, dyslexia, or other such condition, then they must be assigned a mentor/trainer to read and explain to them the entire contents of this manual as well as the safety guidelines, danger, caution, and warning decals on this unit. Such individuals should not be allowed to operate this equipment until they thoroughly understand all of these materials. Failure to do so can result in serious injury or death.

SAFETY ALERT SYMBOL

	<p>THIS SAFETY SYMBOL INDICATES IMPORTANT SAFETY MESSAGES IN THIS MANUAL. WHEN YOU SEE THIS SYMBOL, CAREFULLY READ THE MESSAGE THAT FOLLOWS. BE ALERT TO THE POSSIBILITY OF PERSONAL INJURY OR DEATH.</p>
---	--

Elimination of the hazards listed in this manual should not be construed as providing guarantees that the equipment will meet or exceed all standards or regulations, or will be completely safe to all personnel. The operator should inspect and review the compactor after it is in his possession for adequacy in safety for the function for which it will be used.

SAFETY

SAFETY ALERTS

Safety notices are one of the primary ways to call your attention to potential hazards. The following safety notices are used throughout this manual.

**DANGER**

DANGER indicates a hazardous situation which, if not avoided, will result in death or serious injury.

**WARNING**

WARNING indicates a hazardous situation which, if not avoided, could result in death or serious injury.

**CAUTION**

CAUTION indicates a hazardous situation which, if not avoided, could result in minor or moderate injury.

NOTICE

NOTICE is used to address practices not related to personal injury.

**SAFETY
INSTRUCTIONS**

SAFETY INSTRUCTIONS is used to indicate general instructions relative to safe work practices.

Read, understand and follow the safety guidelines and heed dangers and warnings listed below and contained in this manual as well as on the Compactor itself to promote reliable operation and prevent serious personal injury.

The “signal words” of DANGER, WARNING AND CAUTION have specific meanings to alert you to the relative level of hazard.

Take the safety warnings seriously. If you do not understand them or have questions about them, contact K-PAC™ for assistance.

SAFETY

SAFETY DECAL REQUIREMENTS

When your compactor leaves the factory, SAFETY DECALS are installed for everyone’s protection. The decals are subject to wear and abuse due to the nature of operation. These decals must be maintained. Additional decals may be purchased through your K-PAC™ dealer or directly from the factory. Refer to decal placement illustrations later in this Safety section.

COMPACTOR SAFETY DECALS

The following safety decals are found on your compactor and warn of hazards related to the use of this equipment. Read and understand all safety decals before operating this equipment.

NOTICE	<p>Depending on the Compactor configuration and optional equipment, the actual location of the decals and/or placards may vary slightly from the examples shown.</p>
--------	---

If any safety decals on the equipment are not clearly readable, contact your K-PAC™ dealer.

NOTICE	<p>Specifications, appearance and part numbers for safety decals are subject to change without notice.</p>
--------	---

No.	Part Number	Qty.	Description
1	501940	3	K-PAC LOGO, Large
2	123550	1	K-PAC LOGO, Small
3	503085	2	K-PAC LOGO, Proudly USA Made
4	101437	3	DANGER, Do Not Enter
5	502852	2	DANGER, Stay Clear At All Times When Container Is Off Ground
6	101433	1	DANGER, Keep away from moving parts: Death or dismemberment may occur
7	502850	2	DANGER, Be aware of power lines and overhead obstructions, Contact by the hoist or container could cause serious injury or death to the operator and bystanders
8	134893	4	DANGER, Use LOCKOUT/TAGOUT Before Working On Equipment
9	134892	4	SAFETY INSTRUCTIONS, Before entering or climbing on compactor to perform any work, read and follow OSHA Regulations concerning entry and working in “CONFINED SPACE” OSHA 1910.146 AND “LOCKOUT/TAGOUT” OSHA 1910.147
10	502851	1	WARNING, Pinch Point, Stay Clear Of The Latch Area, Serious Personal Injury May Occur
11	502848	2	WARNING, Escaping Fluid Under Pressure Can Penetrate The Skin Causing Serious Injury Or Death
12	502844	2	CAUTION, Operators - All persons operating this compactor are to read the operators manual and understand the safety messages on this machine
13	502853	1	CAUTION, Do not remove cover except for servicing
14	502857	1	Wipe off seal after dumping

SAFETY

SAFETY DECAL LOCATIONS

Left Side

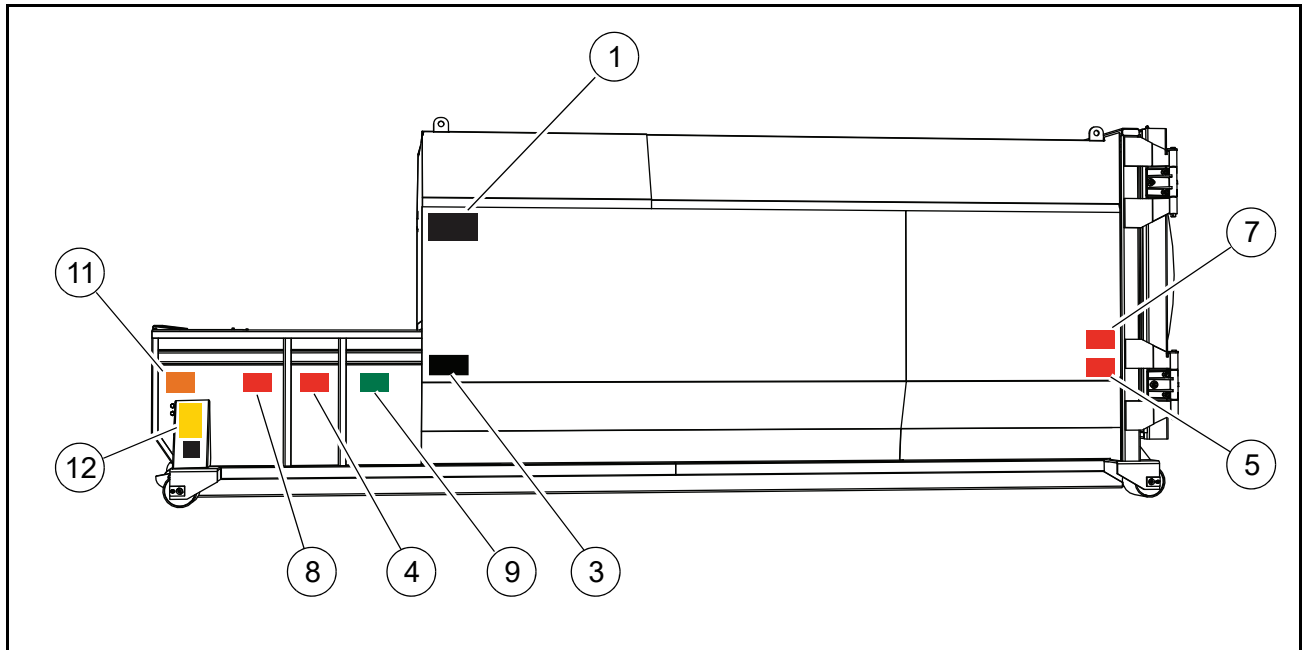

Chamber and Tailgate

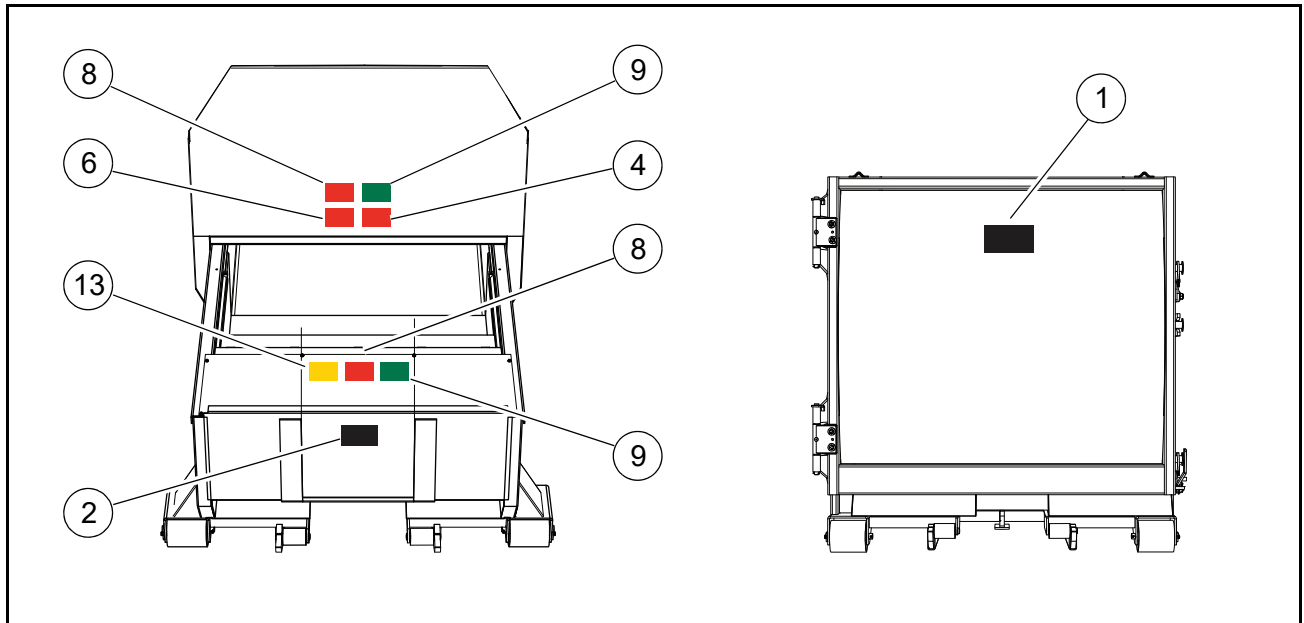

SAFETY

Right Side

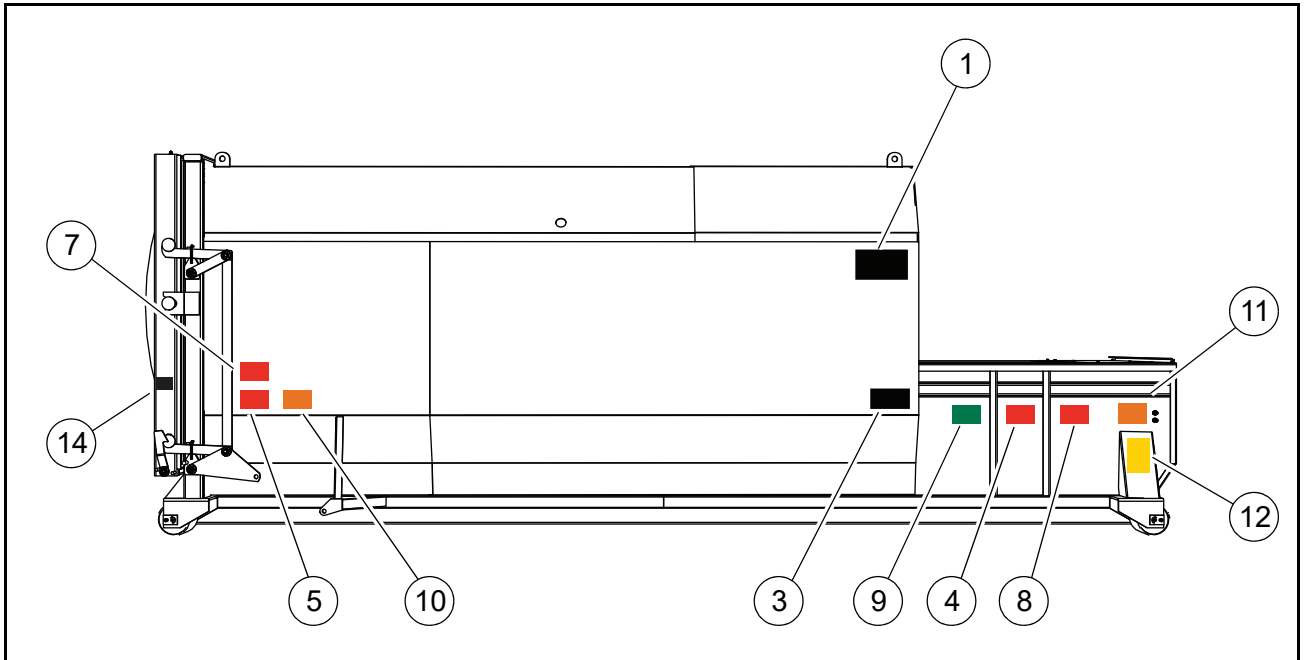

SAFETY

SAFETY DECAL IDENTIFICATION

 <p>501940</p>	 <p>123550</p>	 <p>503085</p>
 <p>101437</p>	 <p>502852</p>	 <p>101433</p>
 <p>502850</p>	 <p>134893</p>	 <p>134892</p>
 <p>502851</p>	 <p>502848</p>	
 <p>502844</p>	 <p>802853</p>	 <p>502857</p>

SAFETY

POWER PACK SAFETY DECALS

The following safety decals are found on your compactor and warn of hazards related to the use of this equipment. Read and understand all safety decals before operating this equipment.

NOTICE	<p>Depending on the Compactor configuration and optional equipment, the actual location of the decals and/or placards may vary slightly from the examples shown.</p>
--------	---

If any safety decals on the equipment are not clearly readable, contact your K-PAC™ dealer.

NOTICE	<p>Specifications, appearance and part numbers for safety decals are subject to change without notice.</p>
--------	---

No.	Part Number	Qty.	Description
1	502840	1	DANGER, High voltage
2	134933	1	DANGER, Do not open cover, Must be a QUALIFIED PERSON to open and access control panel
3	134932	2	DANGER, Arc flash and shock hazard, Appropriate PPE required
4	502847	1	WARNING, These controls shall be located outside the area and beyond the reach of the compactor
5	123550	2	K-PAC LOGO, Small

SAFETY DECAL LOCATIONS

Power Pack

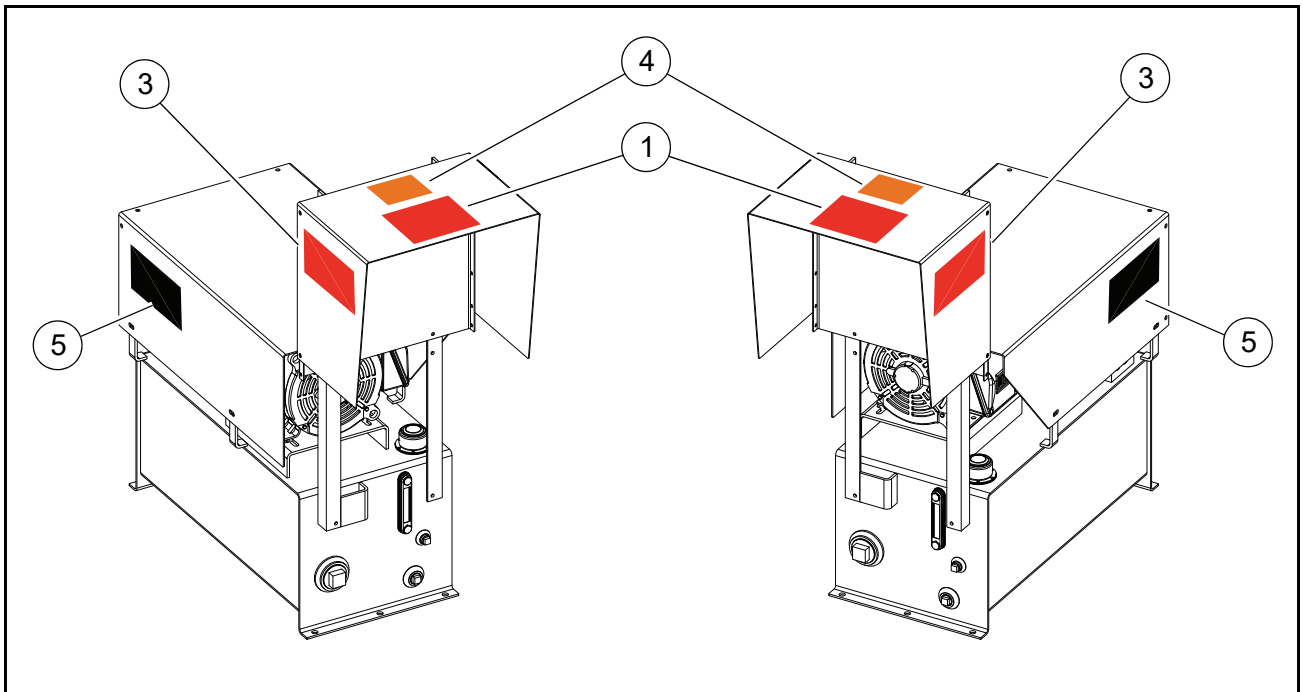

SAFETY

Control Panel

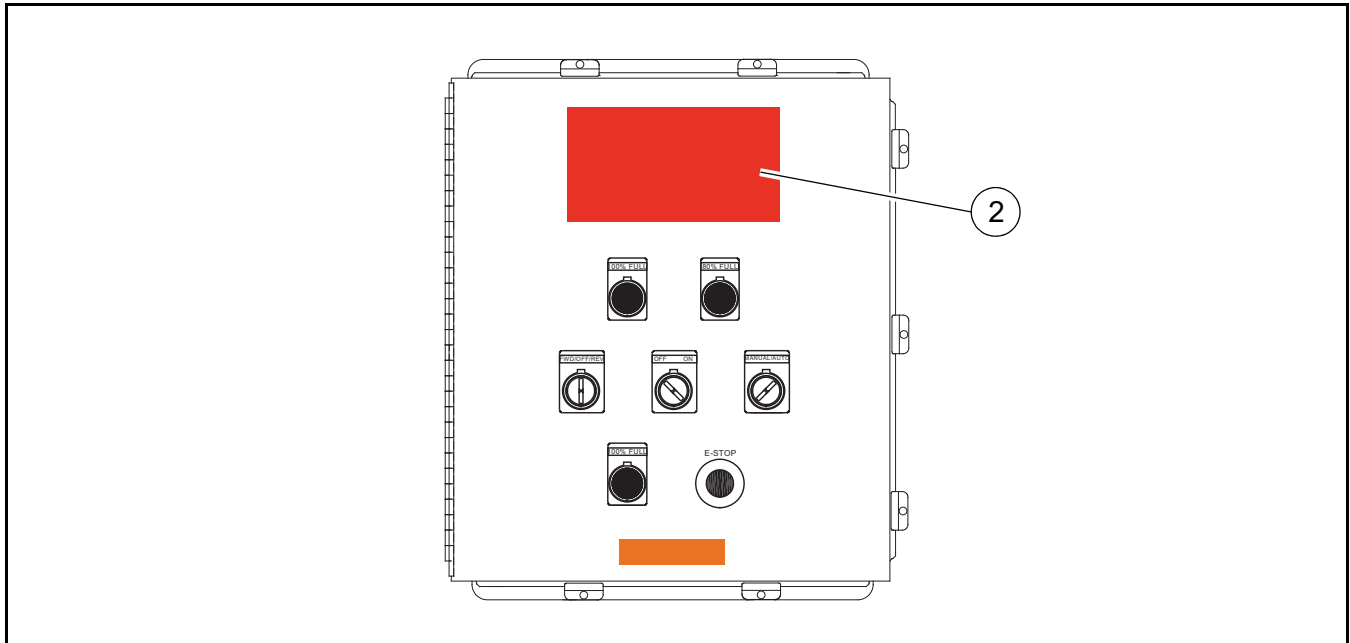

SAFETY DECAL IDENTIFICATION

 <p>502840</p>	 <p>134933</p>	 <p>134932</p>
 <p>502847</p>	 <p>123550</p>	

SAFETY

LOCKOUT/TAGOUT



Before performing any service and/or maintenance, OSHA regulation 1910.147 for LOCKOUT/TAGOUT must be read, understood and followed when performing any service and/or maintenance.

Follow all company procedures for LOCKOUT/TAGOUT policy. Disable and de-energize all systems and apply energy control measures. Also consider stored energy.



Before entering the compactor after LOCKOUT/TAGOUT, OSHA regulation 1910.146 for CONFINED SPACE must be read, understood and followed when performing any service and/or maintenance.

LOCKOUT/TAGOUT PROCEDURE

Per ANSI standard Z245.2-2013, the owner/employer shall have a hazardous energy control LOCKOUT/TAGOUT procedure to follow when performing service and maintenance on stationary compactors where the unexpected energization or start-up of equipment or release of stored energy could cause injury to employees.



Because stationary compactors are offered with many customer request options and installations are unique for each compactor, the following LOCKOUT/TAGOUT procedure provided may not cover all hazards.

A hazard assessment must be performed by the owner/ employer when they implement their hazardous energy control LOCKOUT/TAGOUT procedure to ensure all hazards are addressed.

The following are instructions to LOCKOUT/TAGOUT the compactor to ensure that the stationary compactor is stopped, isolated from all potentially hazardous energy sources and locked out before employees perform any servicing or maintenance where the unexpected energization or start-up of the stationary compactor or release of stored energy.

The following are instructions to LOCKOUT/TAGOUT the compactor to ensure that the stationary compactor is stopped, isolated from all potentially hazardous energy sources, stored energy released and LOCKOUT/TAGOUT applied to prevent the unexpected energization or start-up of the stationary compactor.

- Notify all affected employees that servicing or maintenance is required on a stationary compactor and that the compactor must be shut down and locked out to perform the servicing or maintenance.
- The authorized employee shall refer to the company procedure to perform a hazard assessment to identify the type and magnitude of the energy that the compactor utilizes, shall understand the hazards of the energy, and shall know the methods to control the energy.
- Operate the compactor to place all components in a position so they are not subject to possible free fall and/or movement. Install additional blocking devices to prevent this potential when required.

SAFETY

WARNING	<p>When performing work on the ram after LOCKOUT/TAGOUT has been applied, the ram must be blocked/secured in place.</p>
----------------	---

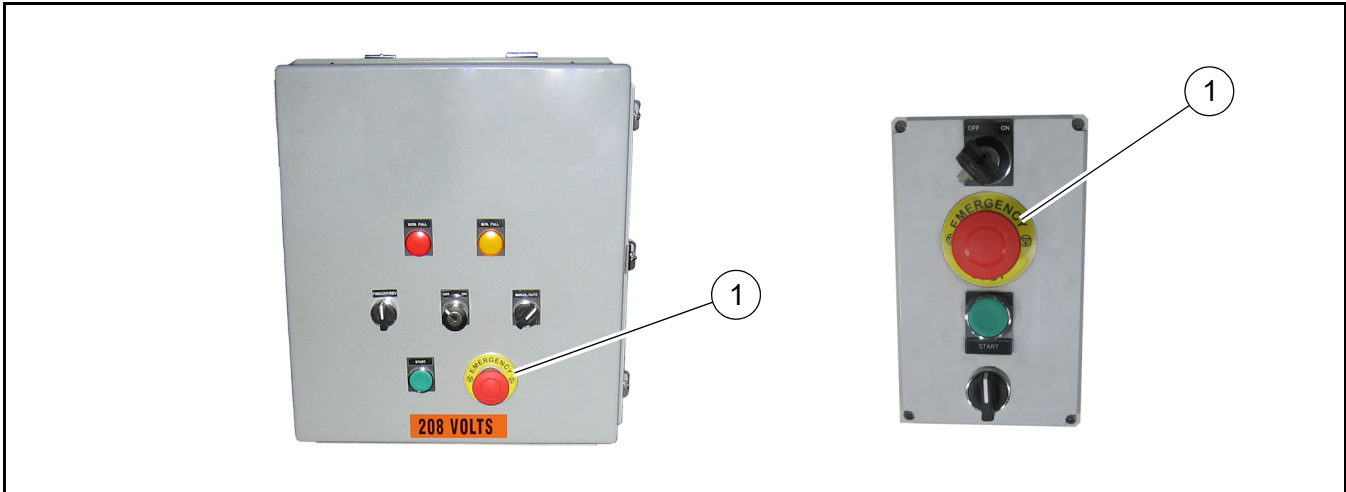

Figure 2

- Depress one of the E-STOP buttons (**Figure 2, 1**) to turn the Power Pack controls Off.

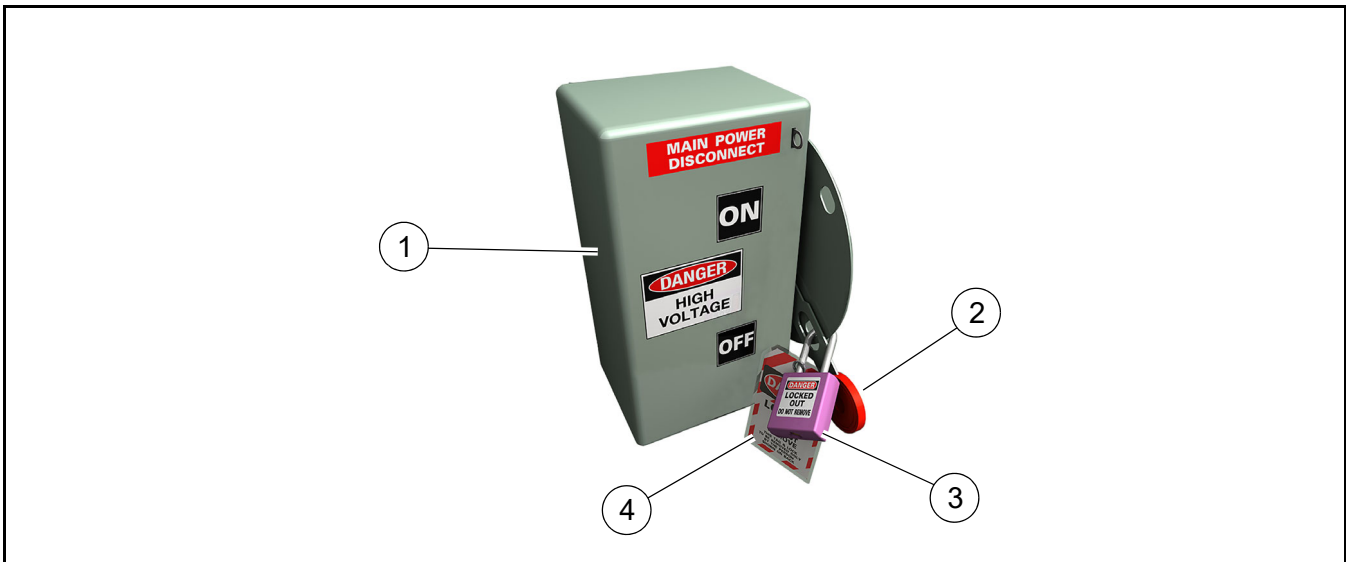

Figure 3

- Identify the Main Power Disconnect (**Figure 3, 1**) for the energy source.
- Switch the lever (**Figure 3, 2**) to the OFF position to shut off the electrical power supply to the Power Pack.
- Apply LOCKOUT/TAGOUT by affixing lock (**Figure 3, 3**) and tag (**Figure 3, 4**) to secure the lever in the OFF position.

SAFETY

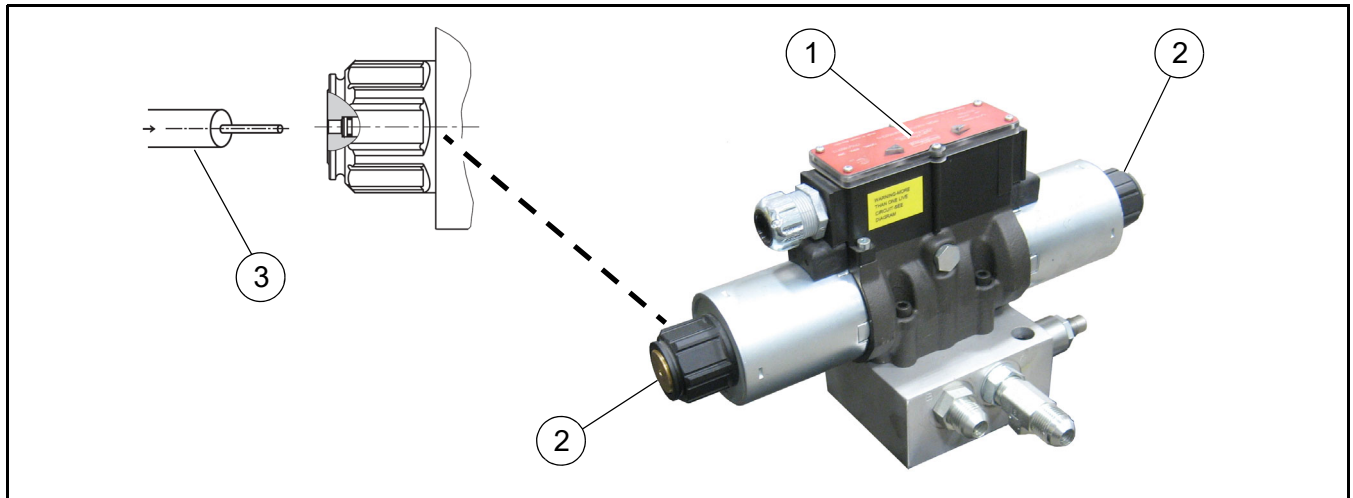

Figure 4

- Stored or residual hydraulic pressure must be relieved after blocking devices are installed. Locate the direct acting directional control valve (**Figure 4, 1**) on the Power Pack.
- Both solenoids (**Figure 4, 2**) on the directional valve have a manual override.
- Insert an 1/8" or less diameter pin or screw driver (**Figure 4, 3**) into the end of both solenoid spools to relieve hydraulic pressure from both hydraulic lines for the ram cylinder.
- Disable the Power Pack by turning the ON-OFF switch (**Figure 5, 1**) to OFF on the control panel. Remove the key and keep in your possession.



Figure 5

- After applying LOCKOUT/TAGOUT to system, verify the system has been isolated and disconnected from the energy source.
- First check that no personnel are exposed.
- Operate the controls to verify they have been disabled.

NOTICE

The stationary compactor is now in LOCKOUT/TAGOUT.

SAFETY

REMOVE LOCKOUT/TAGOUT

The removal of LOCKOUT/TAGOUT should be performed by the same authorized employee that it was applied by. Use the following steps to remove LOCKOUT/TAGOUT and restore the compactor back to service.

- Check the stationary compactor and the immediate area around to ensure that nonessential items are removed from the area.
- Check the compactor and surrounding area to verify that all components are intact.
- Check the work area to ensure that all affected employees are safely positioned or removed from the area.
- Verify that the controls are in neutral.
- Remove the LOCKOUT/TAGOUT lock (**Figure 3, 3**) and tag (**Figure 3, 4**) that secured the lever on the Main Power Disconnect.
- Switch the lever (**Figure 3, 2**) to the ON position to enable the electrical power supply to the Power Pack.
- Insert the key into the ON-OFF switch (**Figure 5, 1**) on the control panel or remote. Enable the Power Pack by turning the ON-OFF switch to ON.

NOTICE

The removal of some forms of blocking may require re-energizing of the stationary compactor before safe removal.

- Reassess area to determine that the equipment is safe for operation.
- Notify affected employees that the servicing or maintenance is completed and the compactor is ready for use.

PROCEDURES FOR WORK IN CONFINED SPACES

The owner/employer shall have a written procedure for work in confined spaces meeting the criteria of OSHA regulation 1910.146. The procedure shall utilize the LOCKOUT/TAGOUT procedure previously provided.

SAFETY INSTRUCTIONS

Before entering or climbing on compactor to perform any work, read and follow OSHA regulations concerning entry and working in “CONFINED SPACE” OSHA 1910.146 and “LOCKOUT/TAGOUT” OSHA 1940.147.

Follow OSHA regulations while performing any work to the compactor.

Follow all safety instructions in your K-PAC™ manual.

Failure to do so can result in serious personal injury or death.

HIGH VOLTAGE SAFETY

High voltage electricity can be dangerous because of many variables. Precautions must be taken against the risk of death or injury. When any kind of electrical work is being undertaken, it is vital that a risk assessment encompassing all electrical hazards be taken. Energized electrical work shall only be performed by or under the direct supervision of a QUALIFIED PERSON.

Guidance for electrical safety comes from several standards:

- General Industry Safety Standards (OSHA 29 CFR 1910)
- Standard for Electrical safety in the Workplace (NFPA 70E)
- IEEE Guide for Performing Arc-Flash Hazard Calculations (IEEE 1584)

OSHA 1910 Subpart “S” (1910.301 to 1910.399) specifies Electrical Safety-related work practices. The latest edition of NFPA 70E is also being used as a guideline for enforcing OSHA electrical safety rules.

SAFETY

DEFINITIONS

OSHA 1910.399 specifically defines a QUALIFIED PERSON as “One who has received training in and has demonstrated skills and knowledge in the construction and operation of electric equipment and installations and the hazards involved.”

The NFPA 70E® 2012 “Standard for Electrical Safety in the Workplace®” definition for a QUALIFIED PERSON is almost identical.

 DANGER	<p>All electrical work when installing and servicing must be performed by a QUALIFIED PERSON.</p>
---	--

NOTICE	<p>QUALIFIED PERSON is one who has received training in and has demonstrated skills and knowledge in the construction and operation of electric equipment and installations and the hazards involved.</p>
---------------	--

ARC FLASH

Arc flash is a phenomenon where a flashover of electric current leaves its intended path and travels through the air from one conductor to another, or to ground. The results are often violent and when a human is in close proximity to the arc flash, serious injury and even death can occur.

Arc flash can be caused by many things. Three factors determine the severity of an arc flash injury:

- Proximity of the worker to the hazard
- Temperature
- Time for circuit to break

Because of the violent nature of an arc flash exposure when an employee is injured, the injury is serious - even resulting in death. It's not uncommon for an injured employee to never regain their past Quality of life.

PROCEDURES FOR ELECTRICAL ARC FLASH AND SHOCK SAFETY

Prior to intentionally coming into contact with energized electrical conductors or circuit parts of 50 volts or greater with the hands, feet or other body parts with tools, probes (energized electrical work), a shock and hazard analysis shall be performed to determine the safe work practices that are required to perform that work.

Those safe work practices shall include the identification of the following, at a minimum:

- Electrical shock and arc flash boundaries
- Personal protective equipment to be worn
- Need for electrically insulated measuring equipment and other tools
- Other specialized work practices to be followed to perform that work safely
- Requirements for the use of an Electrical Hot Work Permit

 DANGER	<p>All latches on the control panel must be secured at all times. Do not loosen latches or open cover unless you are QUALIFIED PERSON.</p>
---	---







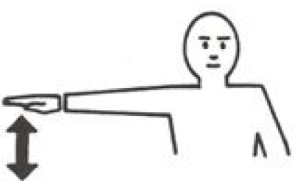

SAFETY

MOST COMMON HAND SIGNALS USED IN THE FIELD

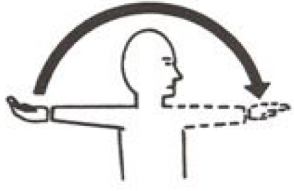
Below are the various hand and arm signals that can be used when visual communication is required and the participants remain relatively close together.

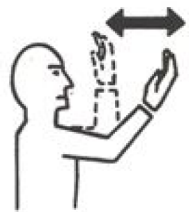
When receiving hand signals, be sure to pay attention to the signalers facial expressions too.

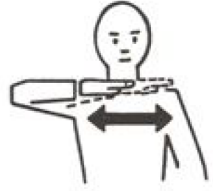
Recognize too that multiple hand signals can be combined in sequence in order to more accurately communicate the thought or action.

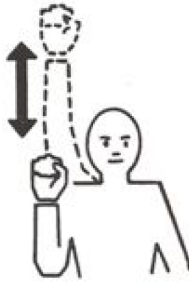
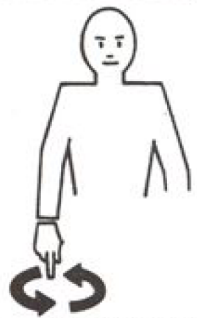
	 <p style="text-align: center;">SLOW IT DOWN - DECREASE SPEED</p>	 <p style="text-align: center;">THIS FAR TO GO</p>	 <p style="text-align: center;">MOVE OUT - TAKE OFF</p>
 <p style="text-align: center;">RAISE EQUIPMENT</p>	 <p style="text-align: center;">MOVE TOWARD ME - FOLLOW ME</p>	 <p style="text-align: center;">STOP</p>	 <p style="text-align: center;">STOP THE ENGINE</p>
 <p style="text-align: center;">START THE ENGINE</p>	 <p style="text-align: center;">COME TO ME</p>	 <p style="text-align: center;">SPEED IT UP - INCREASE SPEED</p>	 <p style="text-align: center;">LOWER EQUIPMENT</p>

INSTALLATION

INSTALLATION REQUIREMENTS

GENERAL

The installer of the stationary compactor shall do so in accordance with the appropriate sections of American national Standard ANSI Z245.2, applicable codes, local ordinances and the manufacturer's recommendations. The installer shall affix to such equipment the date of installation, installer's name and a statement attesting to compliance with ANSI Standards.

MAIN POWER DISCONNECT

Installation shall include a power disconnecting means that can be locked in the OFF position.

Power disconnects and live electrical components shall have adequate work space in accordance with ANSI/NFPA 70, National Electrical Code, Section 110, requirements for electrical installations.

Power disconnects with more than 200 volt operating systems shall be labeled with "ARC FLASH" warning decals on the main disconnect panel face.

INSTALLATION INSTRUCTIONS

IT SHALL BE THE RESPONSIBILITY OF THE INSTALLER OF THE SELF CONTAINED COMPACTORS TO INSTALL COMPACTORS IN ACCORDANCE WITH CURRENT ANSI Z245.2 - 2013 SAFETY STANDARD AND OTHER APPLICABLE CODES. **K-PAC™ DOES NOT ASSUME RESPONSIBILITY FOR INSTALLATION PROCEDURES OF THIS EQUIPMENT.** CONFORMANCE TO APPLICABLE LOCAL, STATE AND FEDERAL LAWS CONCERNING INSTALLATION RESTS WITH THE CUSTOMER.

 WARNING	<p>All involved personnel shall study this manual completely before proceeding. Study the installation carefully to be certain that all safety guards, and safety devices are provided and in the proper place to protect personnel and equipment during and after the installation.</p>
--	---

INSTALLATION SITE

1. Careful consideration should be given to the site selected for the K-PAC™ Compactor.
2. **Concrete Pad:** Ample room should be provided for the collecting vehicle to maneuver, including room to avoid OVERHEAD ELECTRIC AND TELEPHONE LINES. The compactor should be placed on a reinforced concrete pad. Preferred dimensions of the concrete pad are 10'-0" wide and length of 5'-0" greater than the length of the self-contained compactor roll-off platform. It should be a minimum of 3,000 PSI concrete, steel reinforced, 6" thick. For good housekeeping practices, it is recommended that a drain beneath the platform be incorporated in the pad to allow for wash-down, etc.

NOTICE	<p>Concrete should be flush with the surrounding ground level. This is important for roll-off truck access.</p>
---------------	--

NOTICE	<p>The pad must be level on outside 2 feet to allow contact of all four rollers.</p>
---------------	---

To provide accessibility, the concrete pad should be positioned to allow 2'-0" between the container and the building wall if installed parallel with the building. Allow a minimum of 45'-0" of clear space from container end of pad for container handling vehicle.

INSTALLATION

Container guide (optional) should be anchored with bolts grouted in with setting compound approximately 5" deep. Spacing between guides is determined by rail spacing of the containers.

- Dock Installation:** If appropriate options are ordered from K-PAC™, the compactor will be furnished with an open top 4-sided chamber (mounted or unmounted as ordered), or a closed chamber with safety hand and toe rails.

If the compactor cannot be directly abutted to the dock, or if there is any difference in the height between dock and compactor, an appropriately sturdy transition section should be provided (by the customer) and securely affixed to both dock and compactor. Hand and toe rails should be extended as required to suit this transition. **(ANSI Z245.2 - 2013 Standard).**

NOTICE

Transition must allow for pickup of compactor by roll-off truck and return without damage to transition.

- Hopper Options:** There are many hopper options available. Make sure that an appropriate hopper is installed for the application to ensure safe operation. The type of compacted material should be considered to protect operator and any nearby personnel from possible flying debris.
- Guarding:** Protection for personnel from contacting any moving parts or material loaded at the point of operation or other mechanical operations shall be provided by one of the following methods or by other means as effective as the following means:

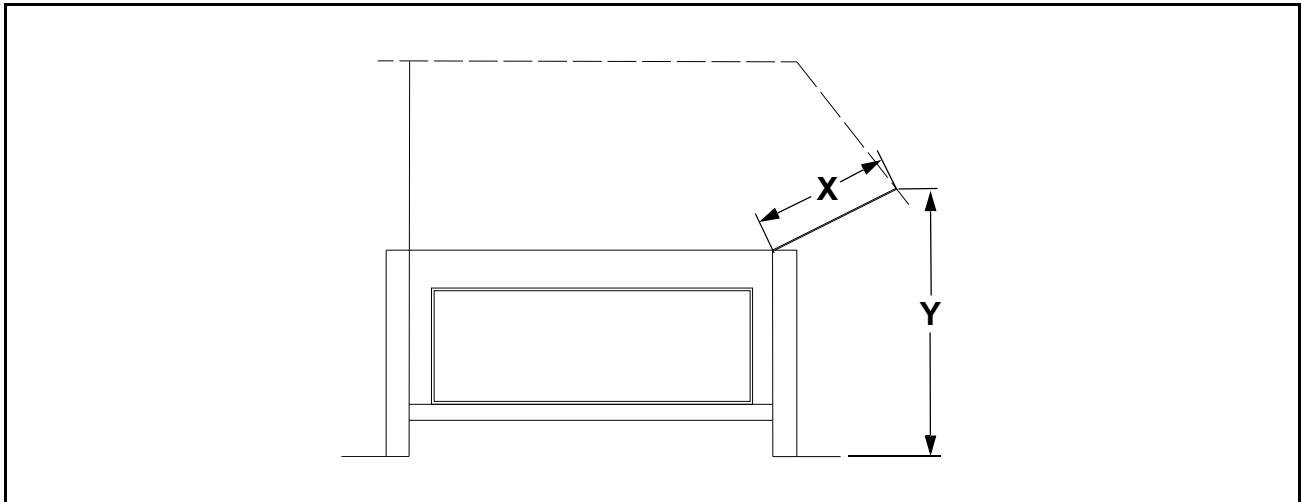

Figure 6

The installation of a guard or loading hopper (**Figure 6**) with a minimum loading height above the working surface of 42 inches (Dimension "Y") and the sum of dimensions "X" and "Y" equaling 84 inches or greater, that shall prevent any person from contacting moving parts or material at the point of operation.

NOTICE

Any guarding provided shall allow adequate clearances for entering and exiting for servicing and operation of the stationary compactor.

- Interlocks:** Access door(s) of loading chambers shall have an interlock system that prevents cycling motion while the access door(s) is/are open unless the provisions of guarding.

When movement of a guard actuates an interlock, the arrangement shall be such that the guard is in place when the interlock is in the position that permits operation of the parts being guarded.

INSTALLATION

7. **Emergency Stop:** Multiple points of operation shall have an emergency stop readily accessible to each point of operation and material feed area. Where possible, the emergency stop should be located within 3 ft of each point of operation, material feed area or access door, if chute fed.
8. **Power Pack:** Must be located within 3' of the loading chamber for access in an emergency. If this is not possible, an auxiliary emergency stop control must be installed within this 3' range. Power pack to be anchored as required by the customer.

 **CAUTION**

The Power Pack must be located so the Control Panel with an Emergency Stop switch is readily accessible to the operator and within three (3) feet of charging chamber access door. If installation requires the Power Pack to be located in a more remote area, a second Emergency Stop should be provided by installing a remote control in the manner described above.

INSTALLATION

ELECTRICAL INSTALLATION

DANGER	<p>All electrical work when installing and servicing must be performed by a QUALIFIED PERSON.</p>
---------------	--

NOTICE	<p>QUALIFIED PERSON is one who has received training in and has demonstrated skills and knowledge in the construction and operation of electric equipment and installations and the hazards involved.</p>
---------------	--

All wiring should be in accordance with Local and National Electric Code regulations. Recommended fuses and wire sizes are listed on a chart below, but the ratings must always meet or exceed any local code.

Motor Horsepower	Line Voltage	Dual Element Time Delay Fusetron - Amps	Minimum Wire Size to 100' Copper	Minimum Wire Size to 200' Copper
10 HP 3 Phase	208	45	8 Ga.	6 Ga.
	230	45	8 Ga.	6 Ga.
	460	25	10 Ga.	8 Ga.



Figure 7

There are three voltage options available, 208, 230 or 460 volts for the 10 Horsepower 3 Phase electric motor. The control panel is prewired to the voltage specified when the compactor was ordered. The voltage that the control panel is wired to is designated with an orange decal (**Figure 7, 1**) on the cover of the control panel.

INSTALLATION

MAIN POWER DISCONNECT

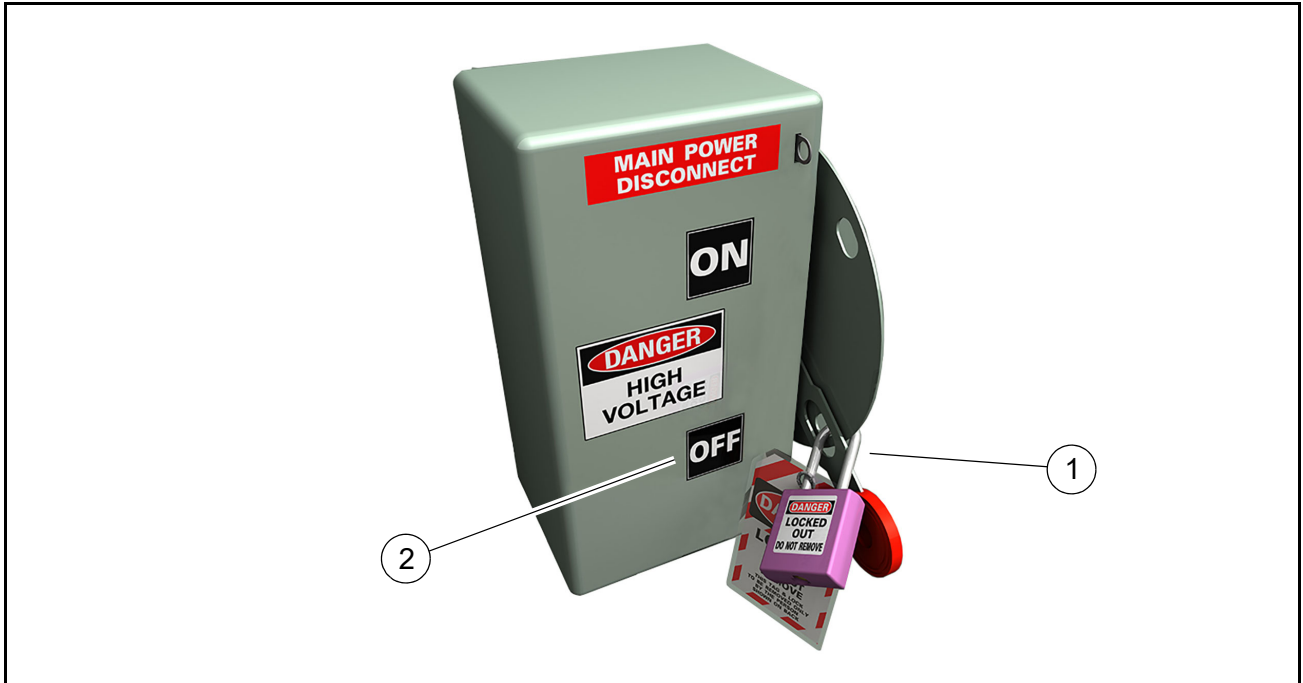

Figure 8

A dedicated 50 Amp fuse disconnect circuit is required to provide power to the power pack. The main power disconnect must have the ability to be padlocked (**Figure 8, 1**) in the OFF position (**Figure 8, 2**) for OSHA LOCKOUT/TAGOUT.

The main power disconnect and live electrical components shall have adequate work space in accordance with ANSI/NFPA 70, National Electrical Code, Section 110, Requirements for electrical installations.

Power disconnects with more than 200 volt operating systems shall be labeled with “ARC FLASH” warning decals on the main disconnect panel face.

Check and verify the voltage the control panel is wired to ensure the Main Power Disconnect is wired to match.

INSTALLATION

WIRE COLORS

The US National Electrical Code only mandates white (or grey) for the neutral power conductor and bare copper, green, or green with yellow stripe for the protective ground. In principle any other colors except these may be used for the power conductors. The colors adopted as local practice are shown in table below. Black, red, and blue are used for 208/230 VAC three-phase; brown, orange and yellow are used for 460 VAC. Conductors larger than #6 AWG are only available in black and are color taped at the ends.

Function	Label	Color, 208/230 VAC	Color, 460 VAC
Line, 3-phase	L1	black	brown
Line, 3-phase	L2	red	orange
Line, 3-phase	L3	blue	yellow
Neutral	N	white	grey
Protective ground	PG	bare, green or green/yellow	green

INSTALLATION

WIRING CONNECTIONS

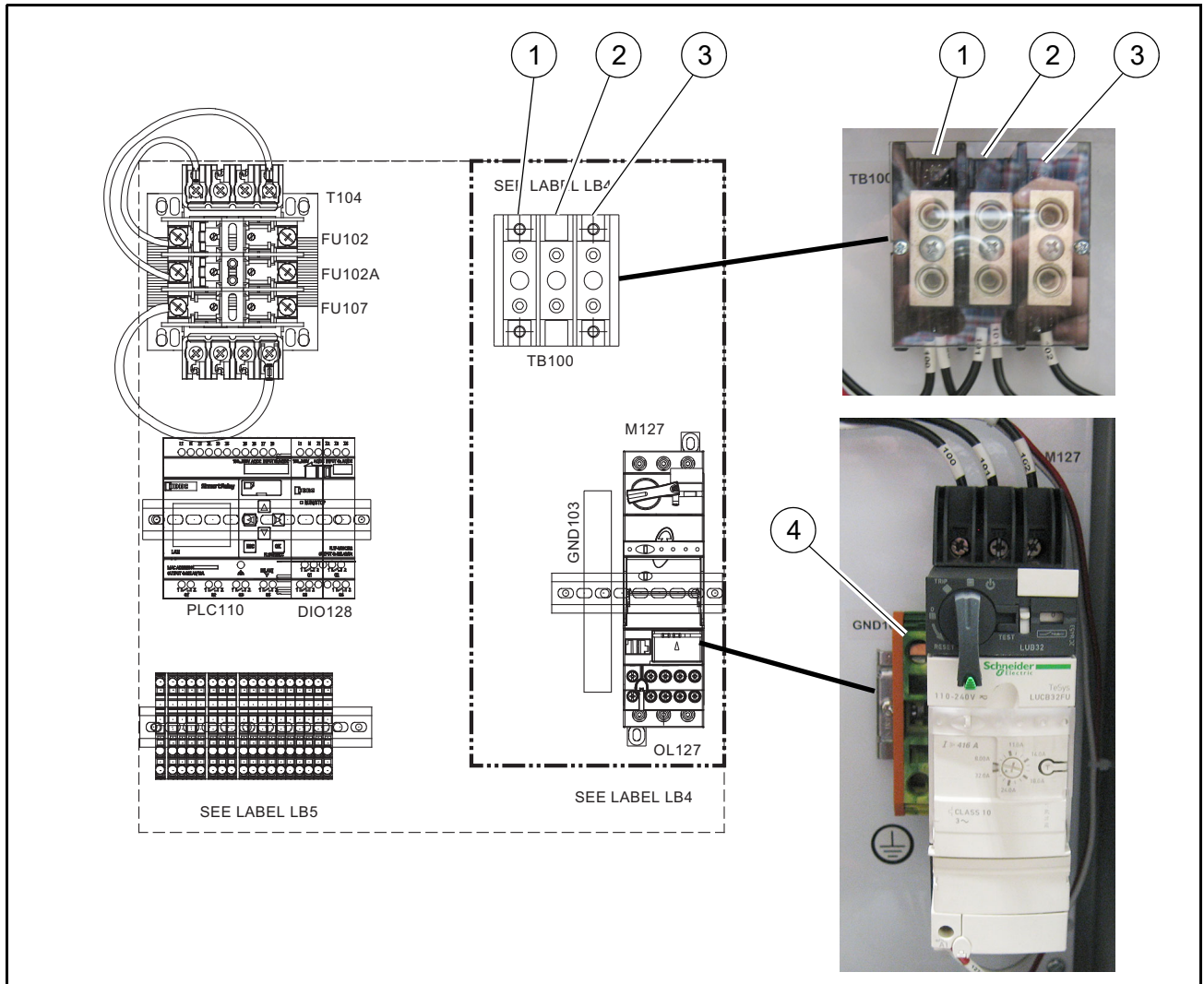

Figure 9

A 3-Pole Power Terminal Block is located at the top right on the back panel inside the Control Panel. The Terminal Block provides a means of connecting the 3-phase line wires from the Main Power Disconnect.

The three line wires are identified as L1, L2 and L3. The L1 wire is connected to the farthest left terminal (**Figure 9, 1**) on the Power Terminal Block. The L2 wire is connected to the middle terminal (**Figure 9, 2**) on the Power Terminal Block. The L3 wire is connected to farthest right terminal (**Figure 9, 3**) on the Power Terminal Block.

A Ground Terminal Block is located on the left side of the Motor Starter and Overload in the control panel. The Motor Starter and Overload are located at the bottom right of the back panel in the Control Panel. The ground wire is connected to the top terminal (**Figure 9, 4**) of the Ground Terminal Block.

INSTALLATION

 **DANGER**

All latches on the control panel must be secured at all times. Do not loosen latches or open cover unless you are a **QUALIFIED PERSON**.

NOTICE

QUALIFIED PERSON is one who has received training in and has demonstrated skills and knowledge in the construction and operation of electric equipment and installations and the hazards involved.

OPERATION

CONTROL PANEL and REMOTE CONTROL

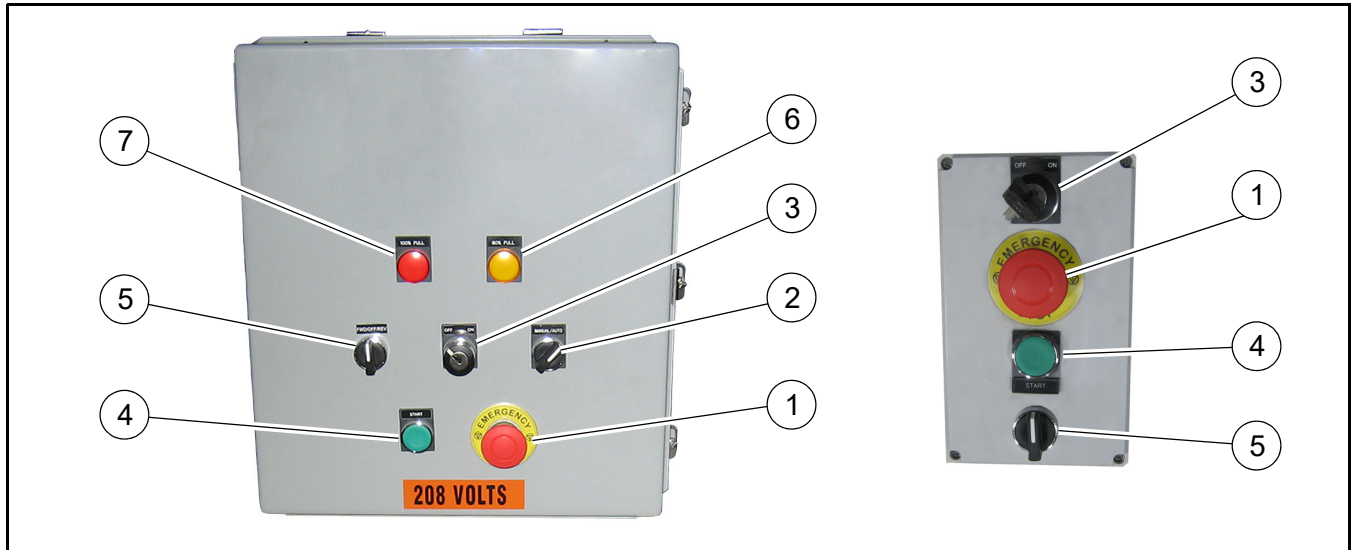

Figure 10

The control box enables the operator to control the Compactor functions and provides a central location for diagnosing any electrical issues.

The following is a brief description for each switch starting from the left and moving right:

NO.	POSITION	DESCRIPTION
1	EMERGENCY Switch	The EMERGENCY Switch provides a means to control the Compactor. Push DOWN on the EMERGENCY Switch to disable all of the Compactor functions. Pull UP on the EMERGENCY Switch to enable the Compactor functions.
2	MANUAL/AUTO Switch	Turn the switch counter-clockwise to select MANUAL mode. When in the Manual mode, the compactor ram cylinders are controlled by the FWD/OFF/REV Switch. Turn the switch clockwise to select AUTO mode. When in the AUTO mode, the compactor ram cylinders are controlled by the START switch.
3	OFF/ON Security Switch	A key-locked OFF/ON Switch is provided to control who can operate the compactor. The lock requires a key to switch between the ON or OFF position. When in the OFF position, the compactor controls are securely disabled. When in the ON position, the compactor controls are enabled.
4	START Switch	DEPRESS the START Switch to start the AUTO pack function. The default setting is three cycles.
5	FWD/OFF/REV Switch	The switch is a momentary switch that is normally in the OFF position. Turn the switch counter-clockwise to FWD position to extend the ram into the container. Turn the switch clockwise to REV position to retract the ram from the container.
6	80% FULL Light	Yellow Light indicates when the container is approximately 80% of full capacity.
7	100% FULL Light	Red Light indicates when the container has reached capacity and is 100% of full capacity.

OPERATION

OPERATING INSTRUCTIONS FOR STANDARD COMPACTORS

1. Place material to be discarded into the charge chamber.
2. Pull UP on the EMERGENCY Switch (**Figure 10, 1**) to enable the Compactor controls.
3. Insert key in OFF/ON Security Switch (**Figure 10, 3**) and turn clockwise to ON position.
4. Determine pack mode and make selection on MANUAL/AUTO Switch (**Figure 10, 2**).

AUTO MODE

NOTICE

AUTO pack mode is programmed for 3 cycles from the factory.

1. Depress the START Button (**Figure 10, 4**) for 1 to 2 seconds, then release.
2. Upon start-up of pack cycle, the ram cylinders will extend until they are fully extended.
3. After the cylinders are fully extended, there should be a 1 second delay.
4. After the extend delay, the ram cylinders will begin retracting. The ram will completely retract and stop for a 1 second delay.
5. The pack cycle will start again and repeat until 3 cycles have been completed.

NOTICE

The default pack cycle times from the factory are 20 seconds for extend and 14 seconds for retract.

MANUAL MODE

1. The FWD/OFF/REV Switch (**Figure 10, 5**) is normally in the OFF position.
2. Turn the switch counter-clockwise to the FWD position to extend the ram cylinders into the container.
3. Turn the switch clockwise to the REV position to retract the ram cylinders.

CONTAINER FULL LIGHTS

There are two container full lights located at the top of the control panel cover. The yellow 80% FULL light (**Figure 10, 6**) indicates when the container is approximately 80% of full capacity. The red 100% FULL light (**Figure 10, 7**) indicates when the container is full and has reached 100% capacity.

START-UP AND TESTING INSTRUCTIONS

POWER PACK START-UP

DANGER

Make sure that all access covers, chamber door or gates are closed and secured.

Before proceeding with this test, make sure that persons are clear of the loading chamber and the container.

Do not test this unit until you have read and understood the operating and maintenance instructions in this manual.

1. With the Main Power Disconnect switch OFF, visually inspect all hydraulic, mechanical and electrical connections on the Power Pack and Compactor. All connections must be tight.
2. Lubricate all oil and grease points on the compactor as instructed in the MAINTENANCE section of this manual.

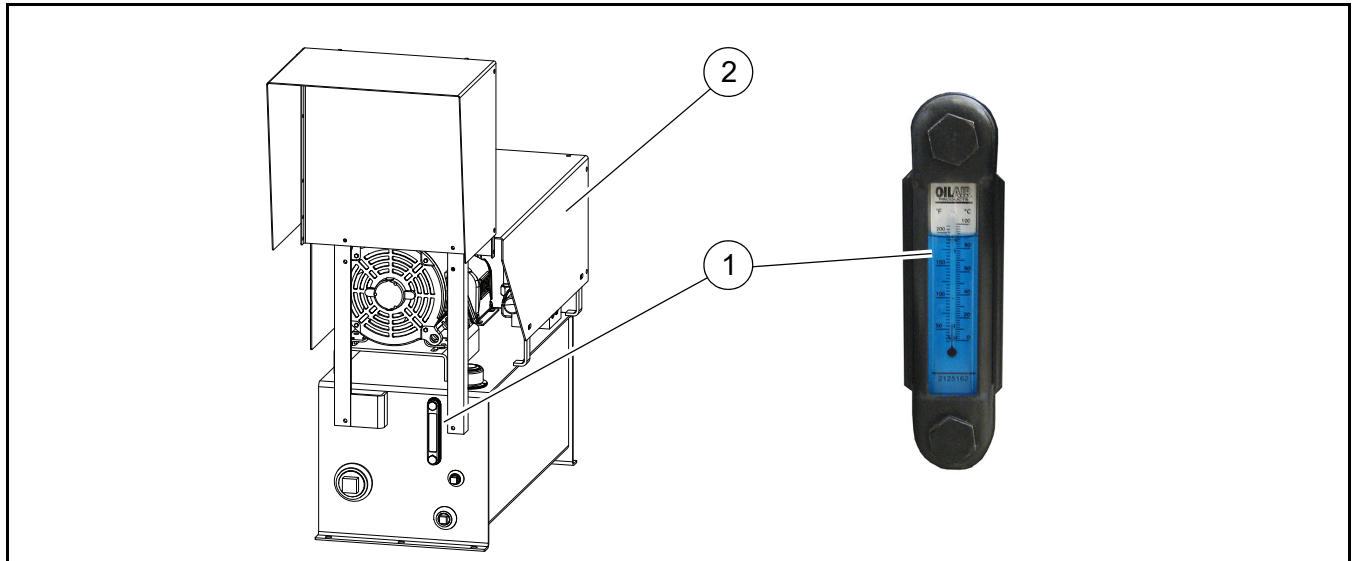

Figure 11

3. Check the hydraulic fluid in the reservoir to be sure it is adequate. The oil must be to the 3/4 level or full on the sight gauge (**Figure 11, 1**). To add or replace, use an ISO Viscosity grade 15 of Northland Tamar Extreme[®] LTE premium anti-wear hydraulic fluid. Hydraulic fluid can be used from an alternative vendor, but the fluid must meet the properties identified in the table in the MAINTENANCE section. Also, any alternative hydraulic fluid must meet the performance specifications identified at the bottom of the table.
4. Remove the cover (**Figure 11, 2**) over the motor and pump to provide access to the motor and pump.
5. Turn the Main Power Disconnect switch to the ON position. BE ALERT for smoking, electrical arcing, or fuse failure. If any irregularity is observed, switch the Main Power Disconnect to the OFF position IMMEDIATELY. Find the source of trouble and make the necessary corrections.

START-UP AND TESTING INSTRUCTIONS

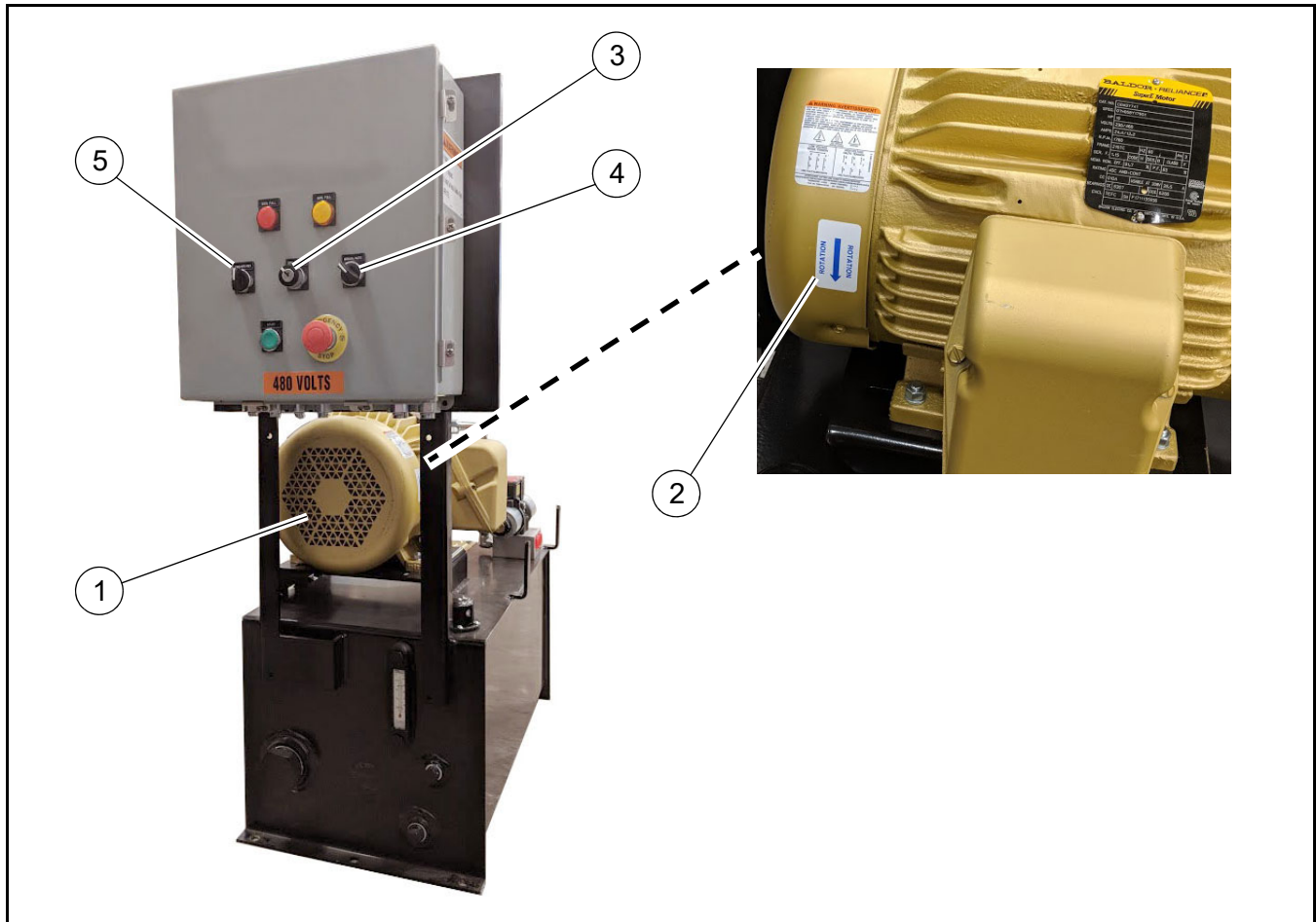

Figure 12

6. Locate the fan cover (**Figure 12, 1**) for inspection of the motor fan to identify motor rotation.
7. Identify label (**Figure 12, 2**) on fan cover to determine the correct motor rotation.
8. Turn the key-locked OFF/ON Switch (**Figure 12, 3**) to the ON position to enable the compactor controls.
9. Turn the MANUAL /AUTO Switch (**Figure 12, 4**) to select the MANUAL mode.
10. Quickly turn the FWD/OFF/REV Switch (**Figure 12, 5**) to the FWD position and back to OFF and stop the motor.
11. Observe if the rotation of the motor fan through the fan cover to determine if the rotation is correct. If the pump runs backwards, STOP IMMEDIATELY!



CAUTION

The pump will be damaged if it is run in reverse even for short periods of time. The direction of rotation must be in agreement with the marking on the motor.

NOTICE

On 3-Phase motors, reversing any two incoming power lines will reverse the pump motor rotation.

12. If rotation is correct, jog the electric motor to prime the pump. If the pump makes excessive noise, shut the system down and check the suction line for leaks or an obstruction.

START-UP AND TESTING INSTRUCTIONS

HYDRAULIC HOSE INSTALLATION

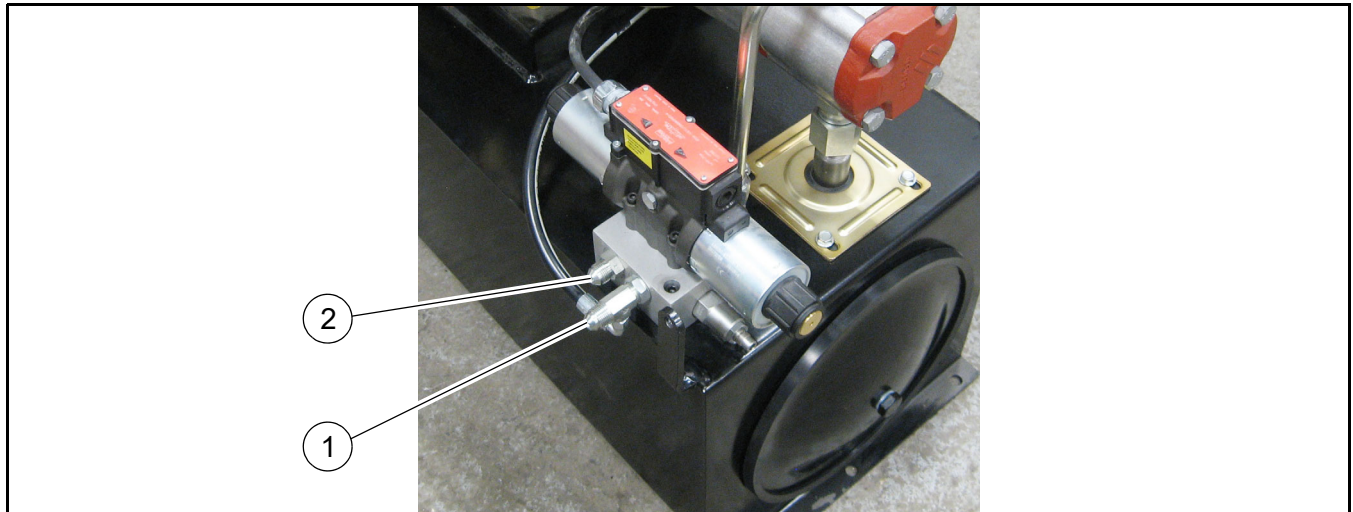

Figure 13

1. Hydraulic hoses are connected to and shipped with the Power Pack. The standard length for the hoses is 12 feet unless a different length was ordered. The hose for the ram cylinders extend function is connected to the tee fitting (**Figure 13, 1**) in the (A) port of the manifold. The hose for the ram cylinders retract function is connected to the adapter fitting (**Figure 13, 2**) in the (B) port of the manifold.

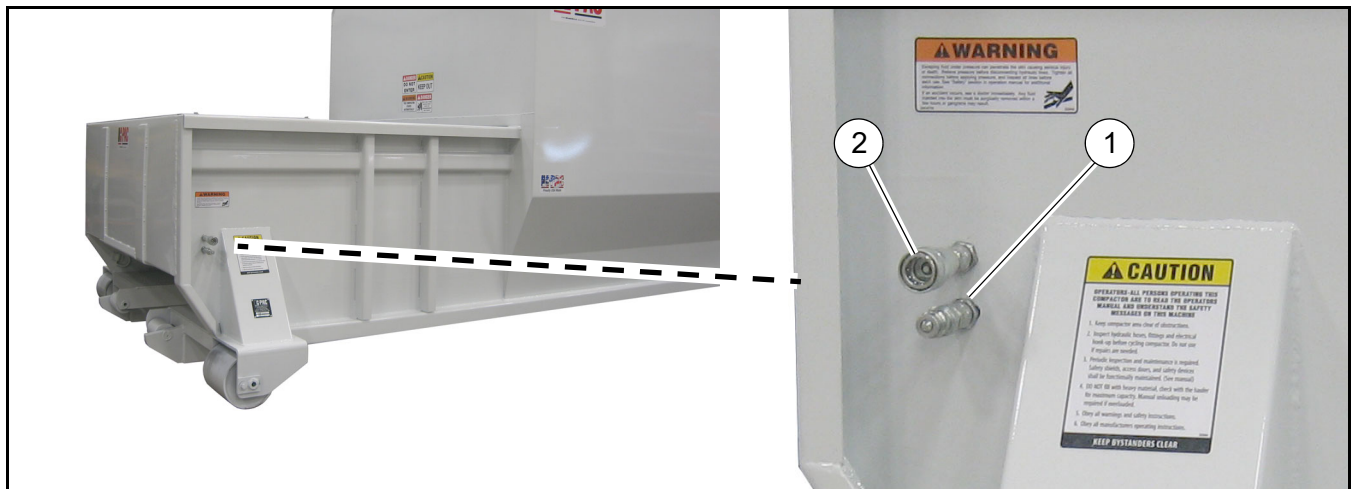

Figure 14

2. The hose connections are located at the left-front of the chamber on the compactor body.
3. The ram cylinders extend hose connected to port (A) on the Power Pack manifold has a quick disconnect coupler on the end of the hose. Connect the coupler to the nipple (**Figure 14, 1**) located at the bottom.
4. The ram cylinders retract hose connected to port (B) on the Power Pack manifold has a quick disconnect nipple on the end of the hose. Connect the nipple to the coupler (**Figure 14, 2**) located at the top.

START-UP AND TESTING INSTRUCTIONS

MANUAL MODE - RAM CYLINDER CYCLING

1. With the MANUAL mode selected, turn the FWD/OFF/REV Switch to the REV position to retract the ram cylinders until they are fully retracted.

CAUTION

When retracting, monitor the hydraulic fluid level in the reservoir for the Power Pack so it is not over-filled. It may be necessary to remove fluid from reservoir.

NOTICE

The hydraulic fluid level must be checked with the ram cylinders completely retracted to prevent over-filling.

2. With the MANUAL mode selected, turn the FWD/OFF/REV Switch to the FWD position to extend the ram cylinders until they are fully extended.
3. After completely extending the ram cylinders, turn the FWD/OFF/REV Switch to the REV position to retract the ram cylinders until they are fully retracted.
4. With the ram cylinders fully retracted, inspect and adjust the hydraulic fluid level in the reservoir.
5. Repeat previous steps several times to remove air from hydraulic system.

AUTO MODE - RAM CYLINDER CYCLING

1. Turn the MANUAL /AUTO Switch to select the AUTO mode.
2. Depress the START Button for 1 to 2 seconds, then release.
3. Upon start-up of pack cycle, the ram cylinders will extend until they are fully extended.
4. After the cylinders are fully extended, there should be a 1 second delay.
5. After the extend delay, the ram cylinders will begin retracting. The ram will completely retract and stop for a 1 second delay.
6. The pack cycle will start again and repeat until 3 cycles have been completed.

NOTICE

AUTO pack mode is programmed for 3 cycles from the factory.

7. After the completion of the packing cycle, the Power Pack should stop automatically and shut down. If it does not, press the EMERGENCY STOP button. Check the timers in power panel. They may be faulty or incorrectly adjusted. Refer to SERVICE section for procedure to set PLC.

VALIDATE INTERLOCKS

Depending on the application and the options ordered and provided, the compactor can be equipped with interlocks. All interlocks need to be verified that they are functioning properly.

WARNING

Make sure the interlocks are installed and functioning properly.

With the factory electric interlock installed, opening of the chamber access door or gate will shut down the power pack. Doors or gate must be closed for power pack to operate.

MAINTENANCE

MAINTENANCE INSTRUCTIONS

It shall be the responsibility of the employer who operates the equipment to ensure the proper caring for, cleaning, inspecting, and maintaining of compaction equipment, in the case of employers who maintain their own equipment, the training of competent personnel for this purpose.

It shall be the responsibility of the employer to establish and follow a program of periodic and regular inspections of compaction equipment, and to ensure that all parts, auxiliary equipment, and safeguards are in safe operating condition and adjusted in accordance with the manufacturer's recommended procedures. The employer shall maintain records of these inspections and of maintenance work performed.

 **DANGER**

Before performing any service and/or maintenance, OSHA regulation 1910.147 for LOCKOUT/TAGOUT must be read, understood and followed when performing any service and/or maintenance.

Follow all company procedures for LOCKOUT/TAGOUT policy. Disable or de-energize all systems and apply energy control measures. Also consider stored energy.

 **DANGER**

Before entering the compactor after LOCKOUT/TAGOUT, OSHA regulation 1910.146 for CONFINED SPACE must be read, understood and followed when performing any service and/or maintenance.

 **DANGER**

When access covers are removed from compactor to perform service or maintenance, they must be reinstalled and secured in position before removing LOCKOUT/TAGOUT.

 **WARNING**

Escaping fluid under pressure can penetrate the skin causing serious injury. Avoid the hazard by relieving pressure before disconnecting hydraulic lines. Tighten all connections before applying pressure.

Search for leaks with a piece of cardboard. Protect hands and body from high pressure fluids.

If an accident occurs, see a doctor immediately. Any fluid injected into the skin must be surgically removed within a few hours or gangrene may result.

 **WARNING**

Flammable spray can be generated by heating near pressurized hydraulic hoses, resulting in severe burns to yourself and bystanders. Do not heat by welding, or using a torch near hoses. Hose can be accidentally cut when heat goes beyond the immediate flame area.

MAINTENANCE

PREVENTIVE MAINTENANCE

We recommend that the user of the K-PAC™ compactors adopt a program of regularly scheduled maintenance procedures. This schedule should be followed to insure against premature failure of mechanical or hydraulic components.

INITIAL CHECK

- All nuts and bolts during the first week of use, and then monthly thereafter.
- Hydraulic reservoir oil level should be at mid to upper range of sight glass with ram retracted.
- Hydraulic lines for leaks.
- Hydraulic hose condition. (Check for damage, kinks, etc.)
- Access covers to be sure fasteners are in place.
- Power Pack. Remove dust and dirt from outside of control box. Wipe off any dirt or grease, oil or moisture.

AFTER EMPTYING

- Wipe tailgate seal and mating surface clean: insure tailgate ratchet is tight.

MONTHLY CHECK

- Check external hoses for chafing, rubbing, or other deterioration and damage.
- Check for any obvious unsafe conditions, such as electrical lines or operator obstructions, in compactor area.
- Check oil level in hydraulic reservoir.
- Wash unit out.

3-MONTH CHECK

- Check functional operation of standard controls and options (stop button, timers, lights, etc.)
- Open top cover and wash out behind ram. Clean out any accumulation of waste material.
- Check hydraulic cylinder and internal hoses for leakage; hoses for chafing and wear.

MAINTENANCE INSTRUCTIONS FOR TAILGATE SEALS

- To prevent leakage, seal and mating surface should be wiped clean after unit has been emptied.
- Periodically inspect seal for abrasions.
- Check that seal is contacting the mating surface properly. If corrosion or damage has occurred on this surface, it may be necessary to sand off smooth.

FILTER MAINTENANCE

- Hydraulic filter should be cleaned after one (1) month of operation and then at regular intervals of not more than six (6) months.
- Filter may be removed from unit by disconnecting pipe on suction side of pump, removing four bolts retaining cover plate, and lifting filter from reservoir. Filter may also be removed by tipping tank at angle and removing cleanout cover on end. With cover removed, filter can be accessed and removed.
- Care should be exercised in cleaning filter to insure that the element is not torn. Clean with soft brush and standard industrial solvent.
- Replace filter after cleaning; tighten union securely. Be sure to tighten pipe to pump before tightening 4 bolts on cover plate. Pump noise and “crackle” sound is most often caused by air entering pump suction line. Tightening the suction fittings will usually eliminate such problems.

MAINTENANCE

YEARLY CHECK

- Electrician to check all electrical connections, check motor resistance (recording successive readings helps to prevent future failure). Under heavy use, grease the motor. (DO NOT OVER-GREASE)
- Hydraulic system - prior to winter season, drain and clean inside of reservoir by removing clean-out cover. Check and clean filter, replace cover and refill. Check for tightness. Refill reservoir with recommended hydraulic fluid.
- Check structure of compactor for potential trouble areas and repair as needed.
- Check hoses to insure that they do not become severely worn before being replaced. A broken hose will allow the reservoir to be pumped dry and ruin the pump.
- Check condition of the ram UHMW slide blocks for wear. Replace if necessary. Keeping the slide blocks replaced when required will greatly extend the life of the compactor floor and sides.
- Check condition of cylinder pivot pins and wear bushings. Replace as necessary.
- Open top inspection cover plate and clean out any accumulation of waste material. Wash area and replace cover. If build-up is significant, then a more frequent clean-out is advised.

NOTICE

Too much accumulation and build-up of waste material can cause hydraulic hose and fitting failure.

HYDRAULIC HOSE MAINTENANCE

- **INSPECT** the hose assembly before each use.
- **REPLACE** the hose assembly immediately if:
 - a. The jacket of the hose appears abnormal.
 - b. You have reason to believe it may be abnormal.
 - c. There is any fluid leakage.
 - d. The couplings are damaged.
 - e. The hose is damaged or kinked.
 - f. The reinforcement is visible through the jacket.
- DO NOT **EXCEED** the maximum recommended working pressure of the hose.
- DO NOT **KINK** the hose assembly.
- DO NOT **BEND** the hose assembly beyond its minimum recommended bend radius.
- DO NOT **EXPOSE** to temperatures in excess of 225° Fahrenheit.
- DO NOT USE AS A **STRENGTH MEMBER** for pulling or lifting equipment.

CAUTION

If replacing hydraulic hose, use only hose that meets or exceeds 3,000 PSI working pressure

MAINTENANCE

LUBRICATION

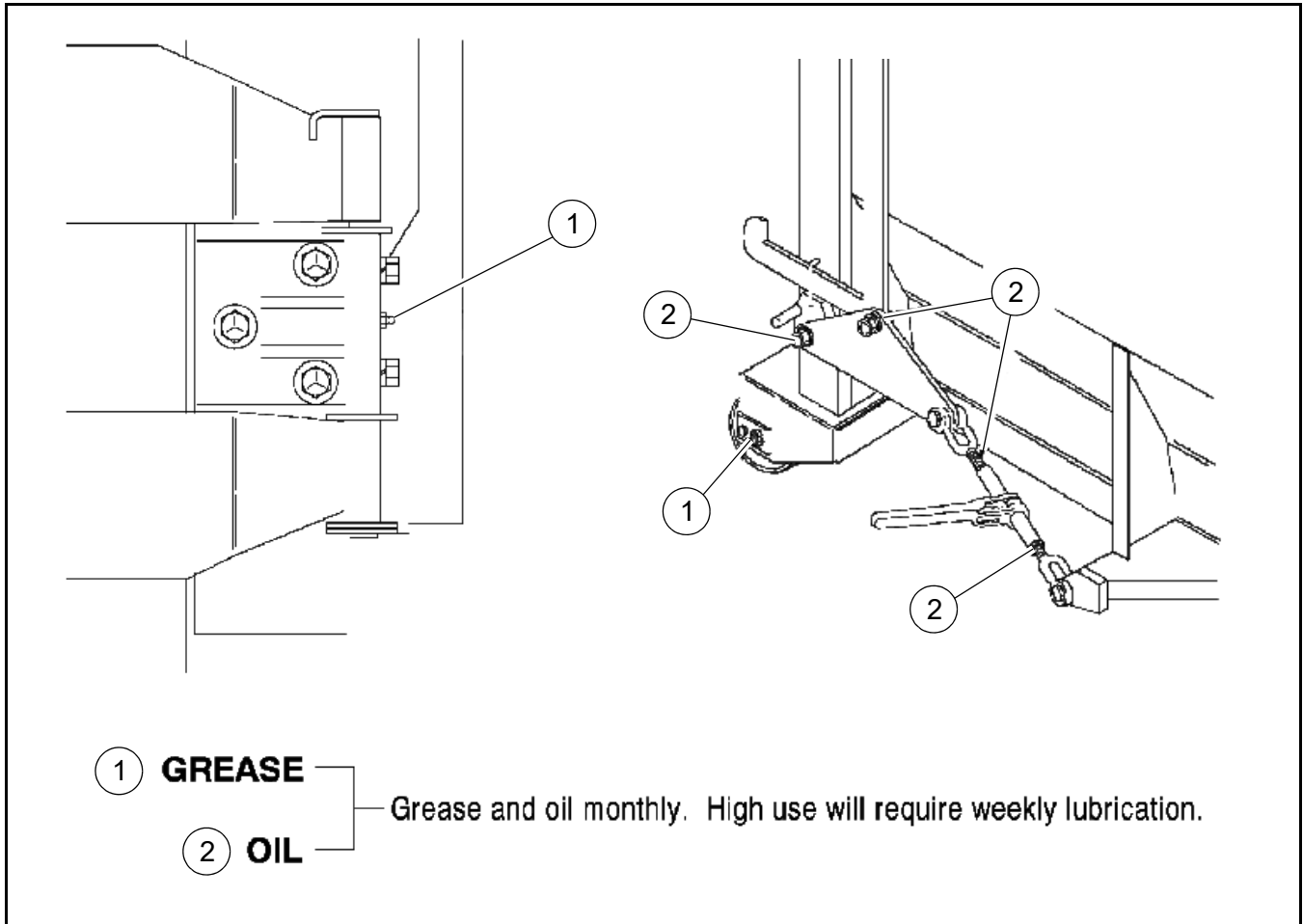

Figure 15

MAINTENANCE

RECOMMENDED HYDRAULIC FLUID

Northland Talamar Extreme[®] LTE premium anti-wear hydraulic fluid is currently used for all K-PAC[™] stationary compactors. An ISO Viscosity grade of 15 is used to function properly in a broad range of ambient-temperature operating environments.

The Talamar Extreme[®] LTE provides improved oil fluidity and pumpability at low temperatures and stable operating viscosities in high temperature applications.

The following table provides the properties for Northland Talamar Extreme[®] LTE premium anti-wear hydraulic fluid. Hydraulic fluid can be used from an alternative vendor, but the fluid must meet the properties identified in the table. Also, any alternative hydraulic fluid must meet the performance specifications identified at the bottom of the table.

PROPERTIES	STANDARD	SPECIFICATION
ISO Viscosity Grade	ASTM D2422	15
Gravity Deg. API	ASTM D287	33.5
Specific Gravity	ASTM D1298	0.857
Pour Point °F	ASTM D97	-55
Flash Point °F, min.	ASTM D92	375
Viscosity: cST @ 40°C	ASTM D445	18
Viscosity: cST @ 100°C		4.6
Viscosity: SUS @ 100°F	ASTM D2161	95
Viscosity: SUS @ 210°F		42
Viscosity Index, min	ASTM S2270	185
Brookfield Viscosity, cP, max. @ -20°C	ASTM D2983	410
Rust Test	ASTM D892	pass
Foam Test, max.	ASTM D892	10/0
		20/0
		10/0
Dielectric Strength, KV min.		35
PERFORMANCE SPECIFICATIONS		
Denison HF-0, HF-2	ASTM D2882	
Vickers / Eaton M-2950-S 35VQ25		

MAINTENANCE

GENERAL MAINTENANCE TIPS

OIL

Even if high-grade oil was installed at start-up, oil does become contaminated in time. Watch for discoloration, foaming or change in viscosity. Ambient conditions as to heat or foreign materials will contribute to problems. Dust and chemicals can be drawn into system vents.

FILTERS

After the start-up of a new system, filter and strainers need very special attention. Chips from pipe threads, metal particles, and other foreign materials can be introduced during hook-up. Clean or replace filter elements after the first month of operation.

RELIEF VALVES

The relief valve is the greatest source of pump and system protection. Likewise, the relief valve is usually the first item to give a warning of other problems. This valve is designed to fail open, or “fail-safe”. Relief valve malfunction is most often due to contaminants in the fluid. This is a good time to clean up the system; flush-out, change filter, open and clean any valve passages if necessary.

PUMP

Pump noise is a definite sign of trouble. Check shaft alignment and condition of coupler first. Cavitation is another cause of pump noise. Check for a restricted suction line, undersized pipes if altered, or dirty filter or strainer. Look for a suction line leak, air getting into the suction line by way of the plumbing or low oil supply will cause pump noise as well as erratic and noisy valves. Finally, a worn pump will also feel hotter than the surface of the reservoir. System pressures will drop and cycle rates will become slower. If pump is replaced, be sure to change filters and check out the entire system during down time. Also, check cleanliness of oil at this time.

HEAT

Heat will be developed by all mechanical devices. The amount of heat will depend upon the use, duty cycle, proper adjustment, age, etc. Hydraulic power packs usually can throw off any excess heat by way of the surfaces of the plumbing and reservoir. Hydraulic power packs should operate in the range of 140° maximum, 160° absolute maximum.

If your new power pack operates too hot, be sure you are using the correct viscosity range and high-grade oil specification. Also important that the oil level is up in the reservoir. Check for any partially open by-pass valves. Check for worn directional valves or leaking cylinders. Internal-system leaks at high pressure are the greatest source of heat.

SERVICE

PLC PROGRAMMING PROCEDURE

HOME MENU - When the PLC is initially powered, the Home Menu (**Figure 16, 1**) is displayed on the PLC control screen. Notice the flashing date and time screen. To navigate to the Main Menu to change timer and cycle settings, press the ESC button (**Figure 16, 2**) once. This will take you to the Main Menu.

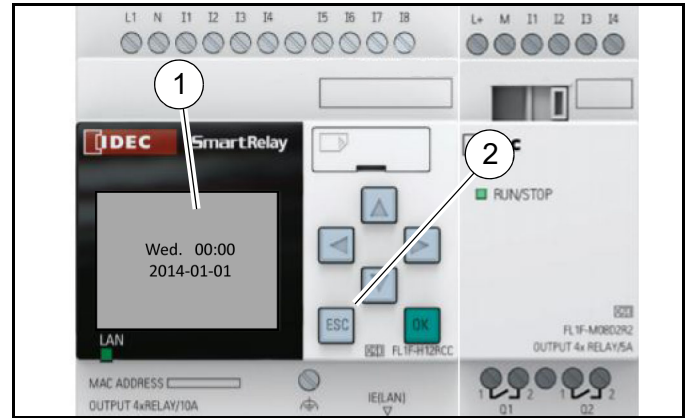

Figure 16

STOP MENU - During normal operation, the top menu line will read Stop (**Figure 17, 1**). This indicates that the program is running. To stop the program, use the navigation buttons (**Figure 17, 2**) to place the cursor on the Stop menu line and then press the OK button (**Figure 17, 3**).

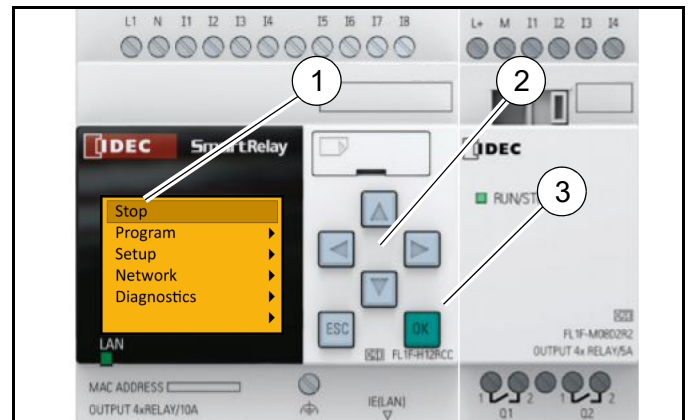

Figure 17

STOP PROMPT MENU - A menu will be displayed prompting if you want to stop the program. To stop the program, use the navigation buttons (**Figure 18, 1**) to place the cursor on the choice of Yes (**Figure 18, 2**). After selecting the Yes choice, press the OK button (**Figure 18, 3**).

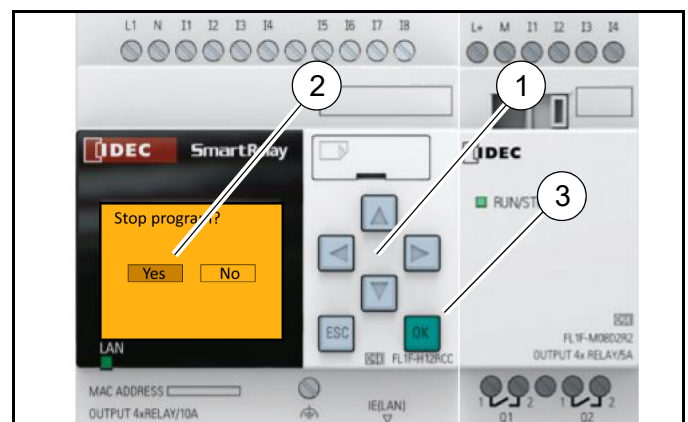

Figure 18

SERVICE

START MENU - When the top menu line reads Start (**Figure 19, 1**), this indicates that the program is not running. To start the program, navigate to the Start menu line by using the navigation buttons (**Figure 19, 2**) to place the cursor on the Start menu line and then press the OK button (**Figure 19, 3**).

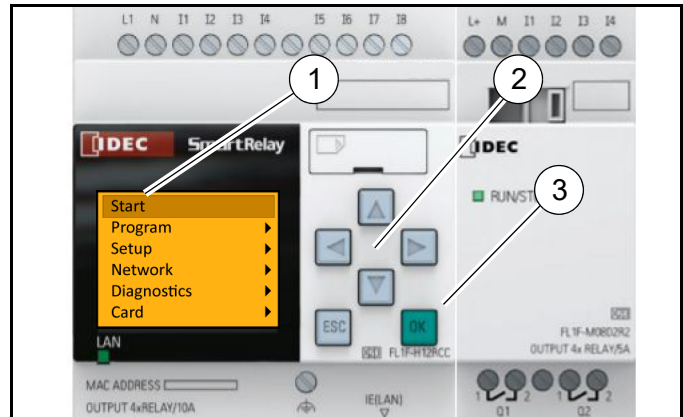

Figure 19

START PROMPT MENU - A menu will be displayed prompting if you want to start the program. To start the program, use the navigation buttons (**Figure 20, 1**) to place the cursor on the choice of Yes (**Figure 20, 2**). After selecting the Yes choice, press the OK button (**Figure 20, 3**).

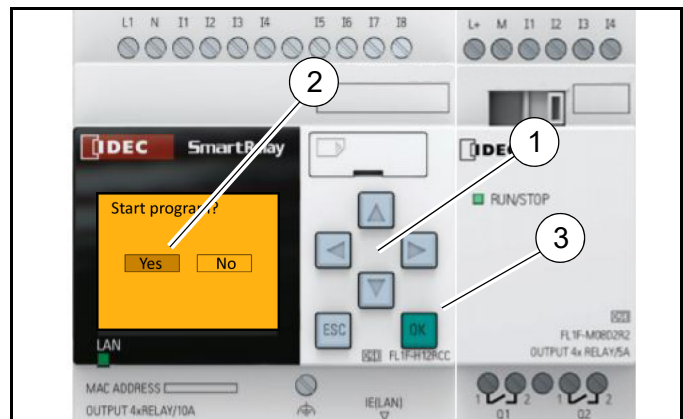

Figure 20

MAIN MENU - Check the top menu line to verify Stop (**Figure 21, 1**) is displayed indicating the program is running. If the menu line displays Start, use the previous menus to start the program.

Use the navigation buttons (**Figure 21, 2**) to select the Program menu line (**Figure 21, 3**). After selecting, press the OK button to navigate to the Program menu.

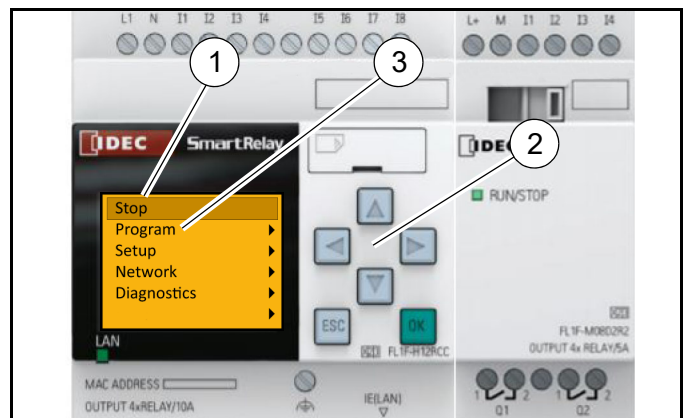

Figure 21

NOTICE

Check the top menu line on the Main menu to verify Stop (Figure 21, 1) is displayed indicating the program is running.

SERVICE

PROGRAM MENU - The Program menu provides two menu options. To identify the Program Name, use the navigation buttons (**Figure 22, 1**) to select Prog Name menu line (**Figure 22, 2**). Select the OK button (**Figure 22, 3**) to navigate to the Prog Name menu.

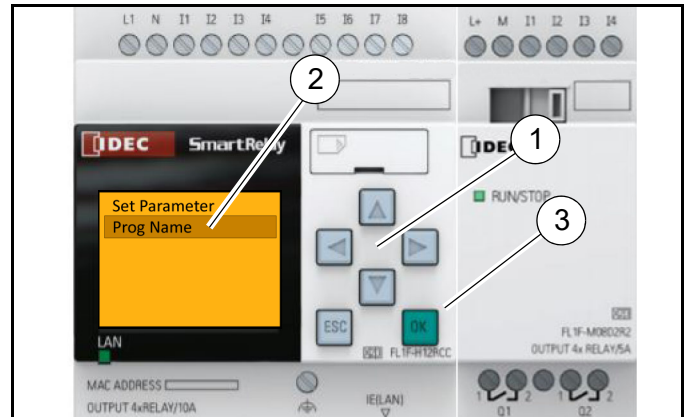

Figure 22

PROG NAME MENU - The Prog Name will be displayed in a text box (**Figure 23, 1**). To return to the previous menu, select the ESC button (**Figure 23, 2**).

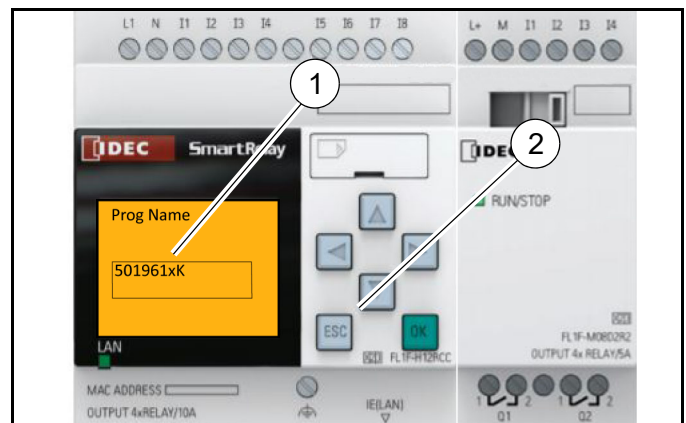

Figure 23

PROGRAM MENU (Continued) - The Set Parameter menu (**Figure 24, 1**) provides access to the timer and cycle settings. Use the navigation buttons (**Figure 24, 2**) to select the Set Parameter menu line. Select the OK (**Figure 24, 3**) button to navigate to the Set Parameter menu.

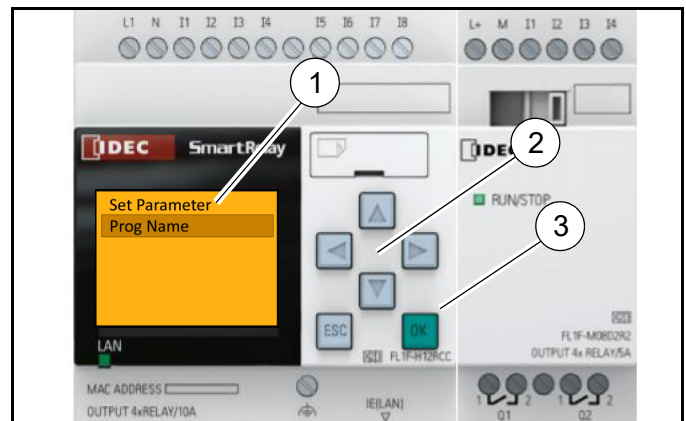

Figure 24

SERVICE

SET PARAMETER MENU - The Set Parameter menu provides access to the timer and cycle settings. To navigate between the menu lines, use the UP and Down navigation buttons (**Figure 25, 1**) to scroll through the menus. Select the OK button (**Figure 25, 2**) to navigate to the selected menu.

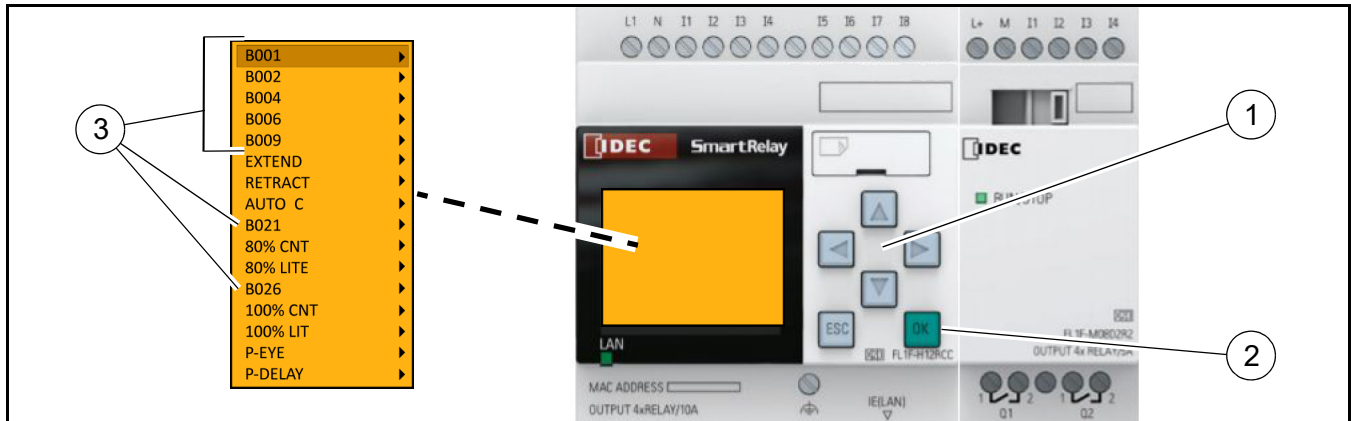

Figure 25

TIMER AND CYCLE SETTINGS

Scrolling is required to access all of the menu name menus. Menu name menus starting with a capital "B" followed by 3 numeric digits should not be selected for editing.

NOTICE

Do not access menu name menus starting with a capital "B" followed by 3 numeric digits. These menu names are preset and used to adjust program parameters.

Use the remaining 9 menu names to access the timer and cycle settings. The following menu names can be selected using the navigation buttons (**Figure 25, 1**) to select.

MENU	DESCRIPTION
EXTEND	Controls the time the ram cylinders will extend. The default setting is 20 seconds.
RETRACT	Controls the time the ram cylinders will retract. The default setting is 15 seconds.
AUTO C	Controls the number of cycles that the unit will complete when you depress the start button or the photo-eye is tripped. The default setting is 3 cycles.
80% CNT	Controls when the 80% light comes ON. The default setting is 5.
80% LITE	Is the timer that controls the time the signal is received before it is sent to the 80% CNT. The default setting is 5 seconds.
100% CNT	Controls when the 100% light comes ON. The default setting is 6.
100% LIT	Is the timer that controls the time the signal is received before it is sent to the 100% CNT. The default setting is 6.05 seconds.
P-EYE	The function will shut down the compactor if the photo-eye becomes blocked for more than a period time. The default setting is 5 minutes.
P-DELAY	Time the compactor will delay the auto-cycle if triggered by the optional photo-eye.

SERVICE

EXTEND MENU - The Extend menu (**Figure 26, 1**) is the first menu to appear. The menu sets the time the ram cylinders will extend. To change the time, press the OK button (**Figure 26, 2**) and a cursor should appear on the extend time box (**Figure 26, 3**). Use the Up and Down navigation buttons (**Figure 26, 4**) to increase or decrease the time. The left or right arrows will allow you to make finer adjustments in tenths and hundredths of a second. The default setting is 19 seconds. After the desired time is obtained, press the OK button again to accept settings.

All of the following timers and counters are adjusted in the same manner as previously described. The order in which they are described will correspond with the use of the Down navigation button.

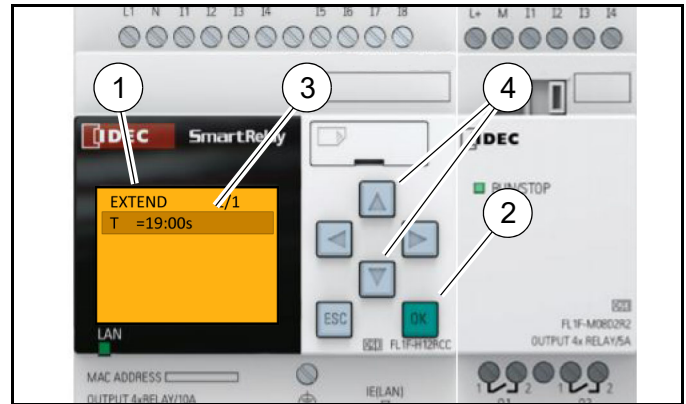

Figure 26

RETRACT MENU - The Retract menu (**Figure 27, 1**) sets the time the ram cylinders will retract. The default setting is 15 seconds (**Figure 27, 2**). After the desired time is obtained, press the OK button (**Figure 27, 3**) again to accept settings.

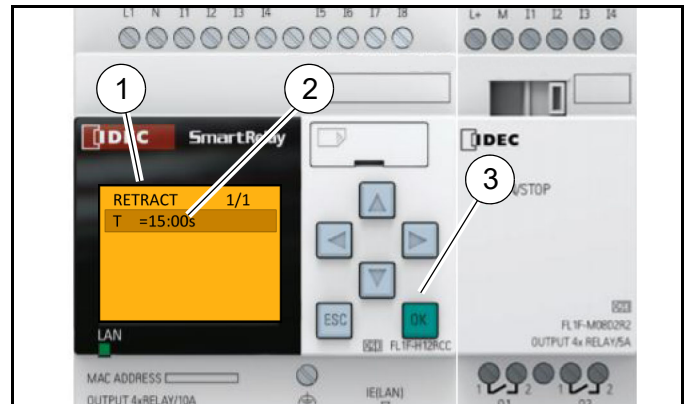

Figure 27

AUTO C MENU - Auto C (**Figure 28, 1**) function controls the number of cycles that the unit will complete after the start button is pressed or the photo eye is tripped. The factory setting is 3 cycles (**Figure 28, 2**).

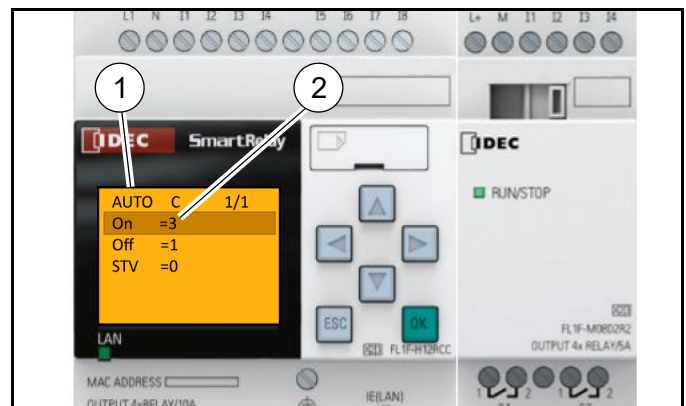

Figure 28

SERVICE

80% CNT MENU - The 80% CNT (**Figure 29, 1**) function controls at what point the 80% light comes On. The default setting is set at five (**Figure 29, 2**), which means that after a total of five signals are received from the 80% LITE MENU, the 80% light will be triggered to come On.

The 80% CNT must be set lower than the 100% CNT, otherwise the 100% light will come On before the 80% light.

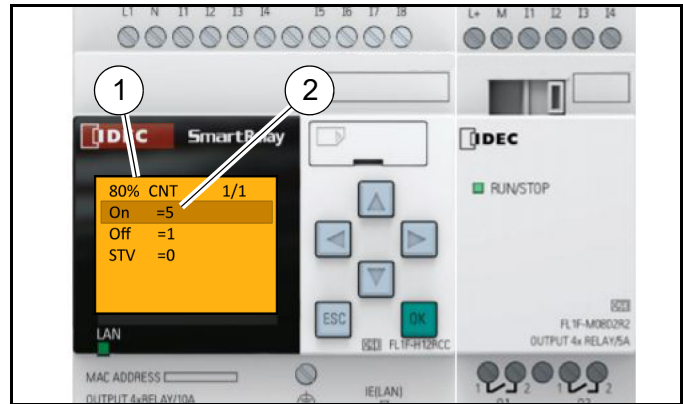

Figure 29

80% LITE MENU - The 80% LITE (**Figure 30, 1**) menu is the timer that controls the time required before a signal is sent to the 80% CNT. The default setting is five seconds (**Figure 30, 2**). For example if the pressure switch is tripped for more than 5 seconds while the unit is in the auto mode and the ram is extending, it will send a signal to the 80% CNT counter.

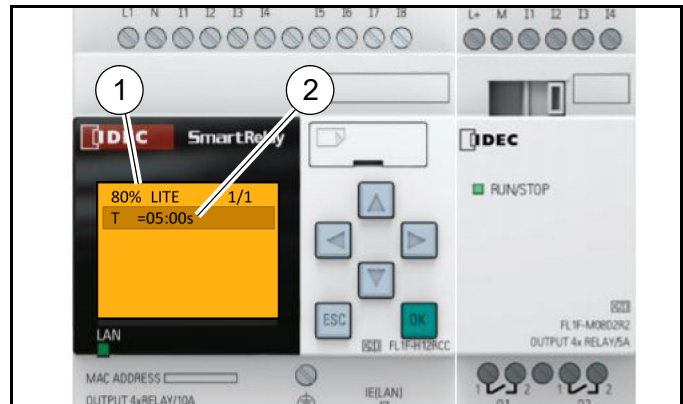

Figure 30

100% CNT MENU - The 100% CNT (**Figure 31, 1**) function controls at what point the 100% light comes On. The default setting is set at six (**Figure 31, 2**), which means that after a total of six signals are received from the 100% LIT MENU, the 100% light will be triggered to come On.

To reset the 100% light after it has come On, depress the Emergency Stop. After depressing, pull Up again to resume normal operation.

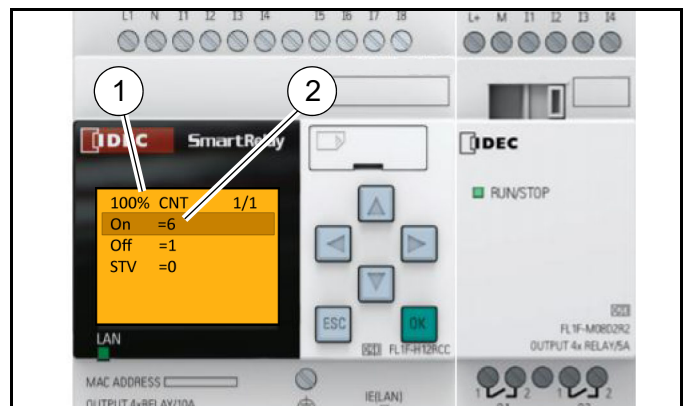

Figure 31

SERVICE

100% LIT MENU - The 100% LIT (**Figure 32, 1**) menu is the timer that controls the time required before a signal is sent to the 100% CNT. It's default setting is 6.05 seconds (**Figure 32, 2**). For example if the pressure switch is tripped for more than 6.05 seconds while the unit is in the auto mode and the ram is extending, it will send a signal to the 100% CNT counter.

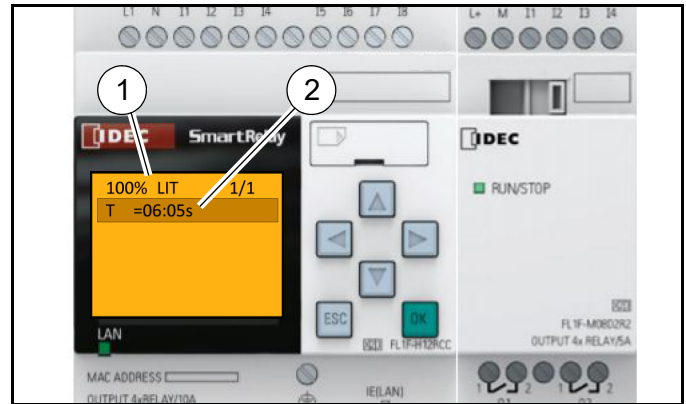

Figure 32

NOTICE

It is important that the 100% LIT timer is set longer than the 80% LITE timer or else the 100% light will trigger before the 80% light.

P-EYE MENU - The P-EYE function (**Figure 33, 1**) will shut down the compactor if the photo eye becomes blocked for more than a predetermined time. The default setting for the P-EYE function is 5 minutes (**Figure 33, 2**). This function prevents the unit from running indefinitely and overheating, also known as auto shut-down.

If this timer is tripped, the Emergency Stop must be shut OFF and switched ON to reset and resume normal operation.

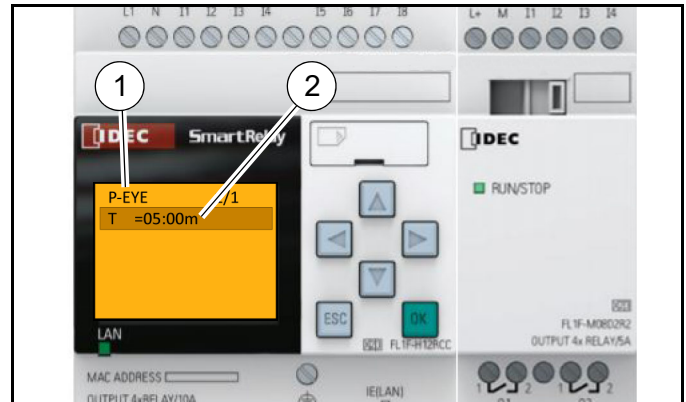

Figure 33

P-DELAY MENU - The P-DELAY (**Figure 34, 1**) is the time in which the compactor will delay the auto cycle if triggered by the photo-eye. The default setting is 4 seconds (**Figure 34, 2**). This feature is used so that the photo-eye must send a signal to the PLC for 4 seconds before it starts the auto-cycle.

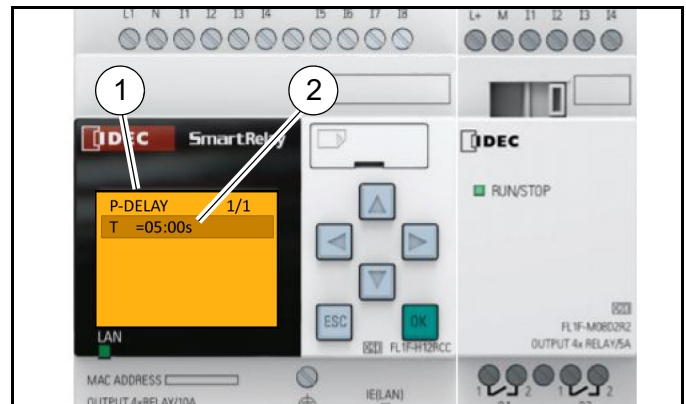

Figure 34

SERVICE

MAIN RELIEF ADJUSTMENT

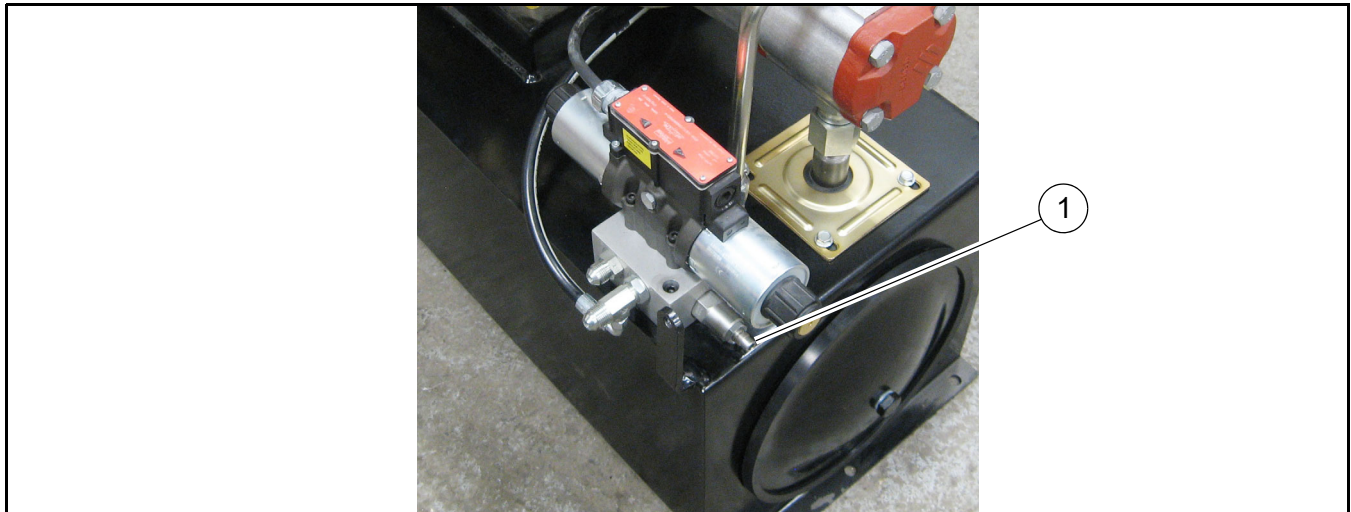

Figure 35

1. Disconnect Power Pack hoses from compactor to eliminate the ram cylinders with built in by-pass.
2. Locate pressure gage installed on Power Pack.
3. Select the MANUAL mode on the MANUAL/AUTO Switch (**Figure 16, 2**) located on the control panel.
4. Turn the FWD/OFF/REV Switch counter-clockwise to the FWD position to activate the extend function.
5. Hydraulic pressure will build against the uncoupled Quick Couplers.
6. Observe the pressure reading on the pressure gage. Release the FWD/OFF/REV Switch and it will return to the OFF position.
7. If pressure was not 2,100 psi or pressure desired then continue on.
8. Loosen relief valve lock nut (**Figure 35, 1**) and turn relief clock-wise to raise or counter-clockwise to lower as required.

NOTICE

Maximum pressure setting is 2,100 PSI and must not be exceeded.

9. Retighten relief valve lock nut.
10. Repeat steps 4 through 8. If the pressure reading was 2,100 psi, the main relief is properly set.
11. Reconnect the hoses to compactor and restart unit to check operation.

SERVICE

PRESSURE SWITCH ADJUSTMENT



Figure 36

1. Refer to the MAIN RELIEF ADJUSTMENT procedure and lower the main relief setting to 1850 psi.
2. Locate the pressure switch (**Figure 36, 1**) installed below the control panel on the Power Pack.
3. Remove the locking screw (**Figure 36, 2**) from the switch to enable the switch to be adjusted.
4. Make 12 turns counter-clockwise to lower the switch setting.

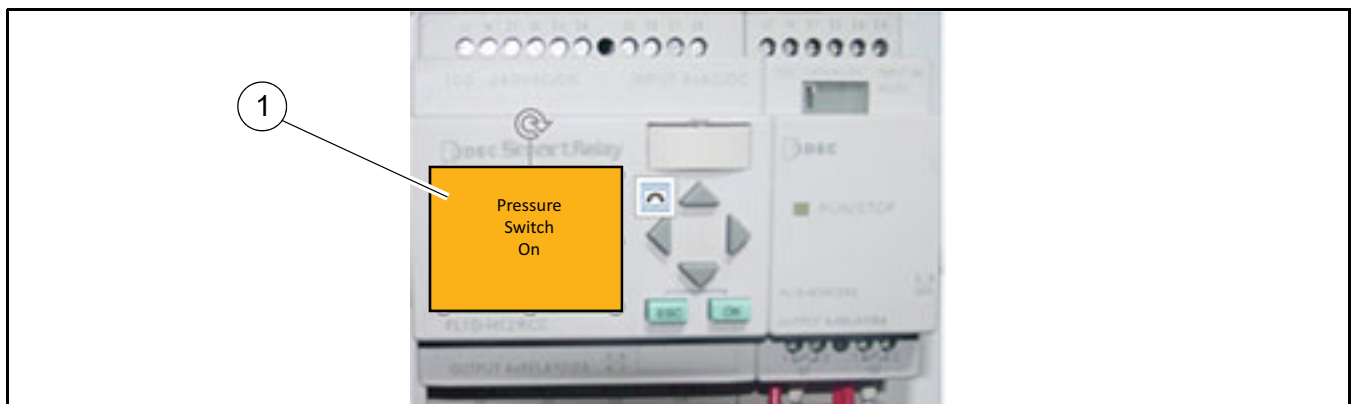
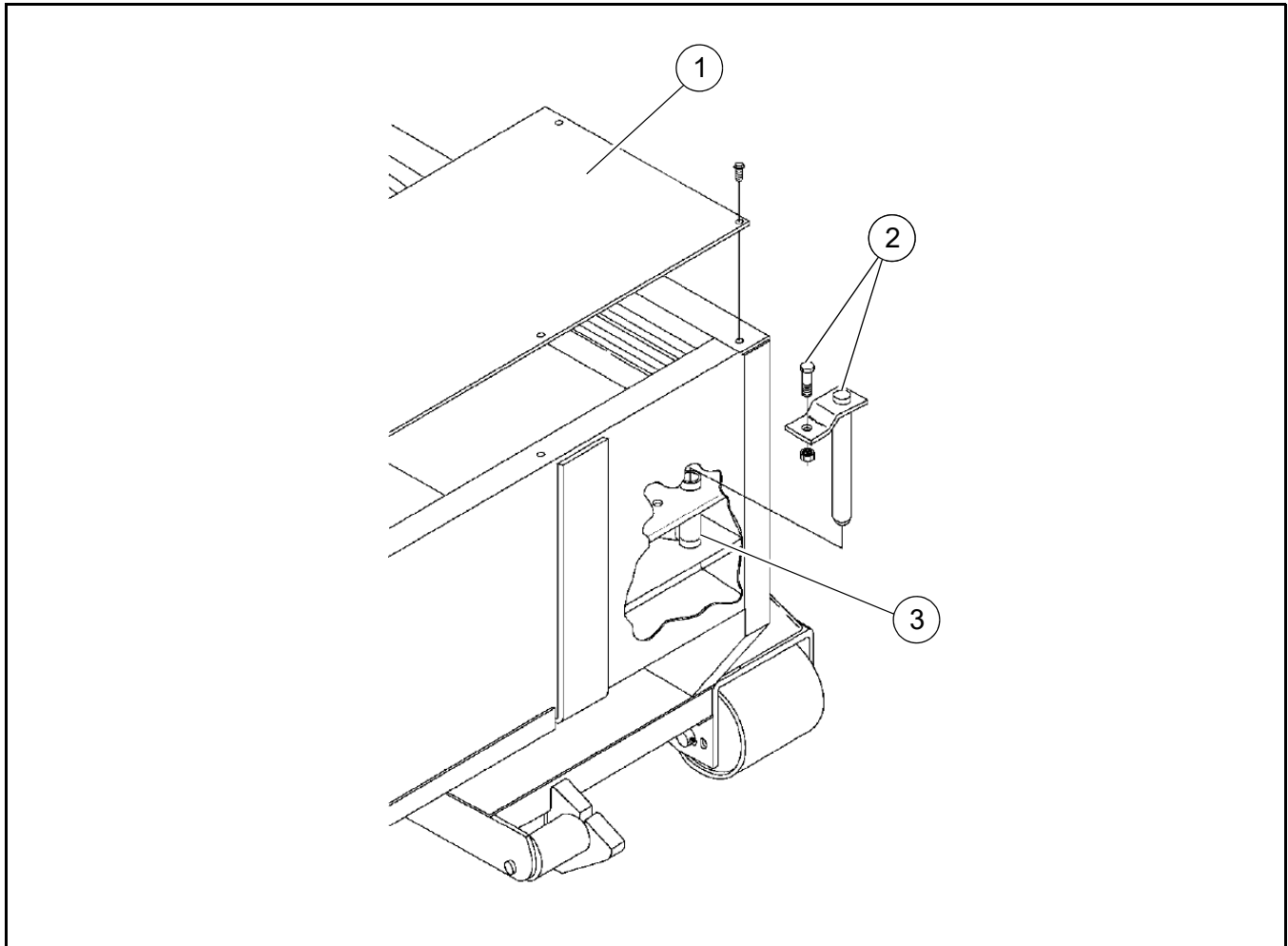

Figure 37

5. Repeat the procedure for setting the main relief and monitor the screen on the PLC in the control panel to determine if the pressure switch signal was received. A message (**Figure 37, 1**) will be displayed on the PLC screen when the pressure switch signal is received.
6. If a pressure switch signal was not received, turn the pressure switch clock-wise a partial turn and repeat the procedure.
7. Repeat until the pressure switch signal is received. This indicates the pressure switch is properly set at 1,850 psi.
8. Insert and tighten the locking screw so the pressure switch maintains its adjustment.
9. Reset the main relief to its original setting of 2,100 psi.

SERVICE

CYLINDER PIVOT PIN INSPECTION**Figure 38**

1. Remove access cover (**Figure 38, 1**) as shown.
2. Remove pin at each end of cylinder by removing bolt and pin (**Figure 38, 2**). Check condition of pin and bushing in cylinder (**Figure 38, 3**). If pin or bushing show significant wear, replace.
3. When re-installing pins, make sure retaining pin is tightened securely.

SCHEMATICS

CONTROL PANEL VOLTAGE OPTIONS

The Power Pack control panel is available in three different voltage options. The available voltage options are 208, 230 and 460 Volt AC. During manufacturing the control panel will be wired to the voltage specified on the sales order.

The only control panel differences between voltages is the wiring of the Control Transformer. The transformer has multiple terminals that are used to set the appropriate voltage setup.

CONTROL TRANSFORMER WIRING

208 VOLT AC - The 103 wire is attached to the H2 terminal (**Figure 39, 1**) on the Control Transformer.

230 VOLT AC - The 103 wire is attached to the H3 terminal (**Figure 39, 2**) on the Control Transformer.

460 VOLT AC - The 103 wire is attached to the H4 terminal (**Figure 39, 3**) on the Control Transformer.

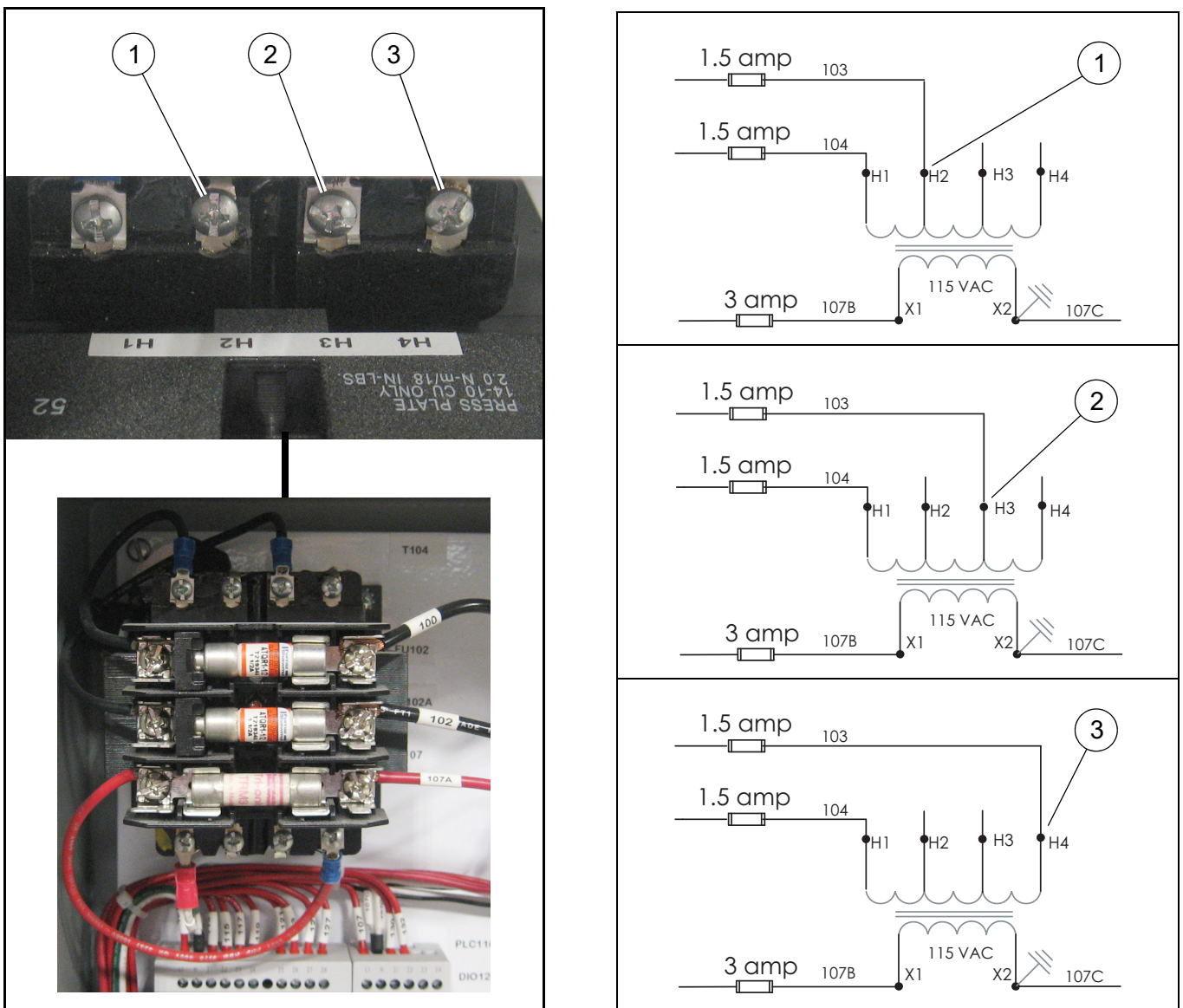
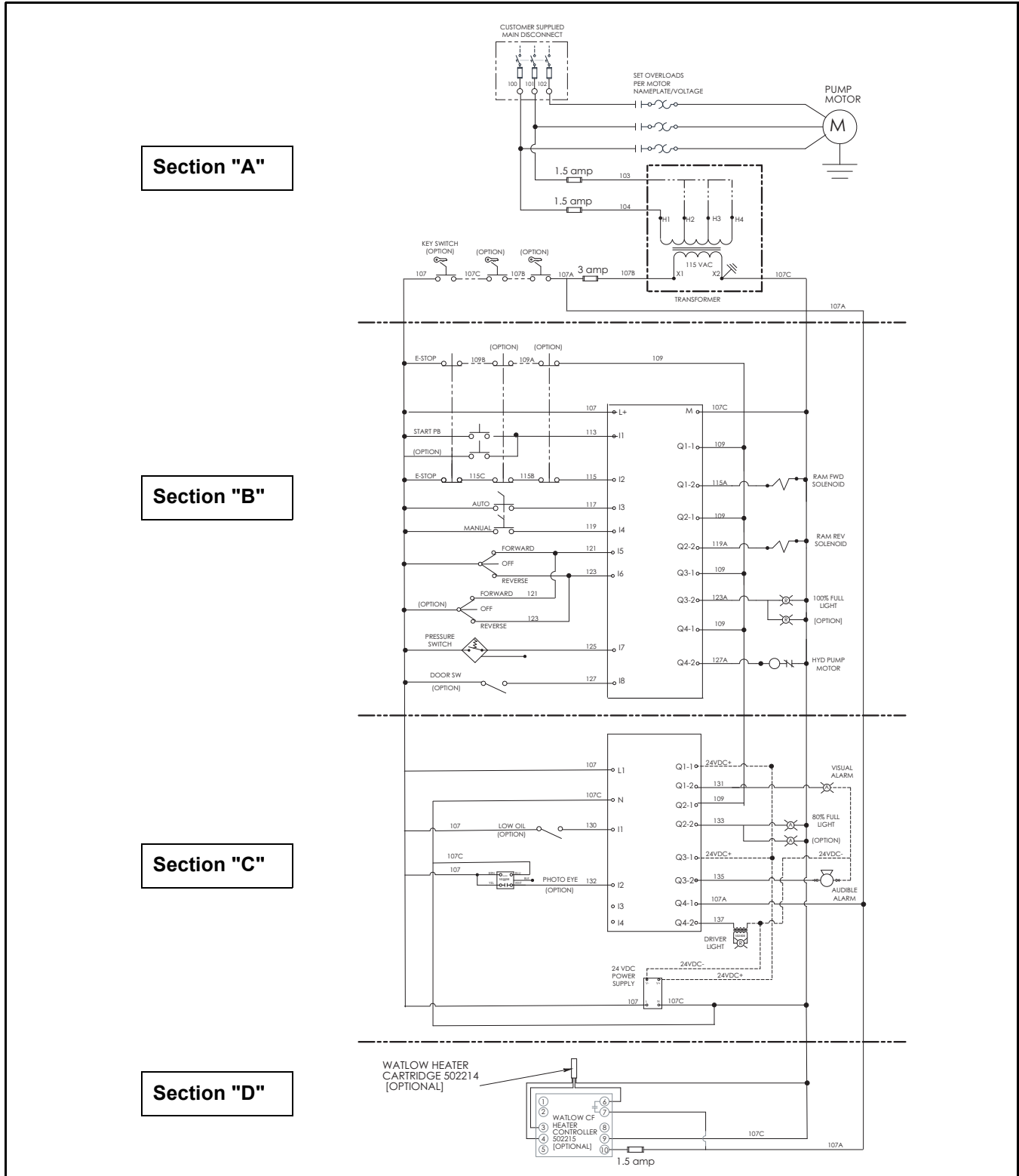

Figure 39

SCHEMATICS

POWER PACK ELECTRICAL SCHEMATIC

208, 230, 460 VAC, 10HP, 3 PHASE, 60 HERTZ



SCHEMATICS

ELECTRICAL SCHEMATIC SECTIONS

Section "A"

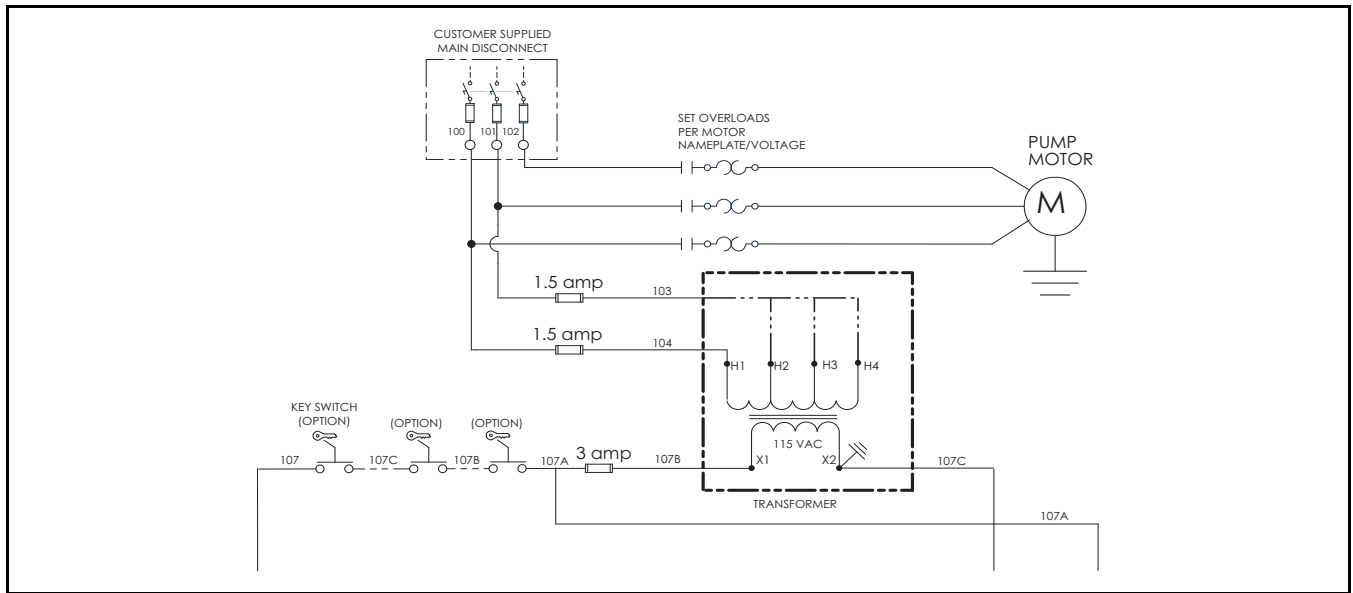

Section "B"

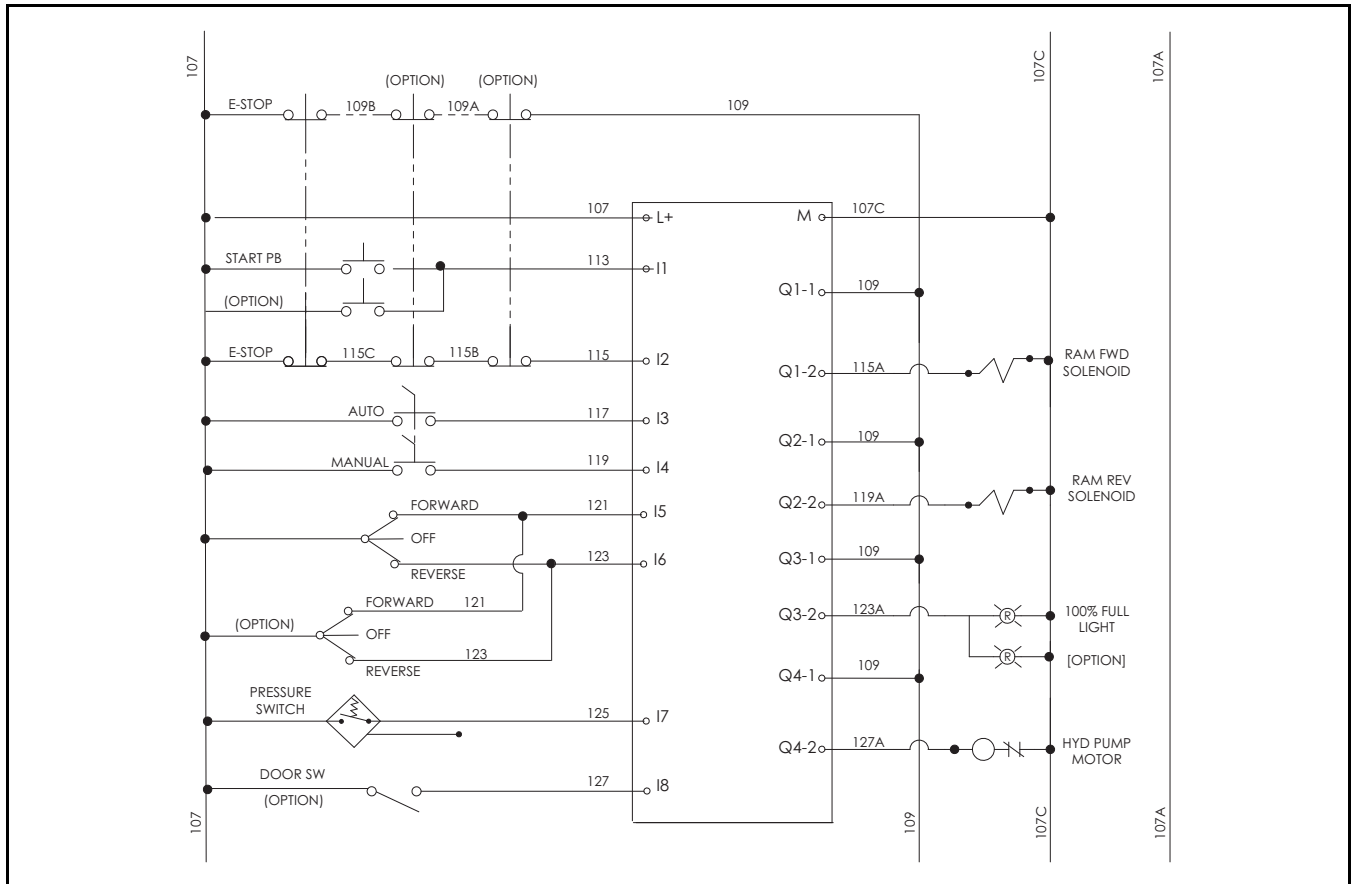

SCHEMATICS

Section "C"

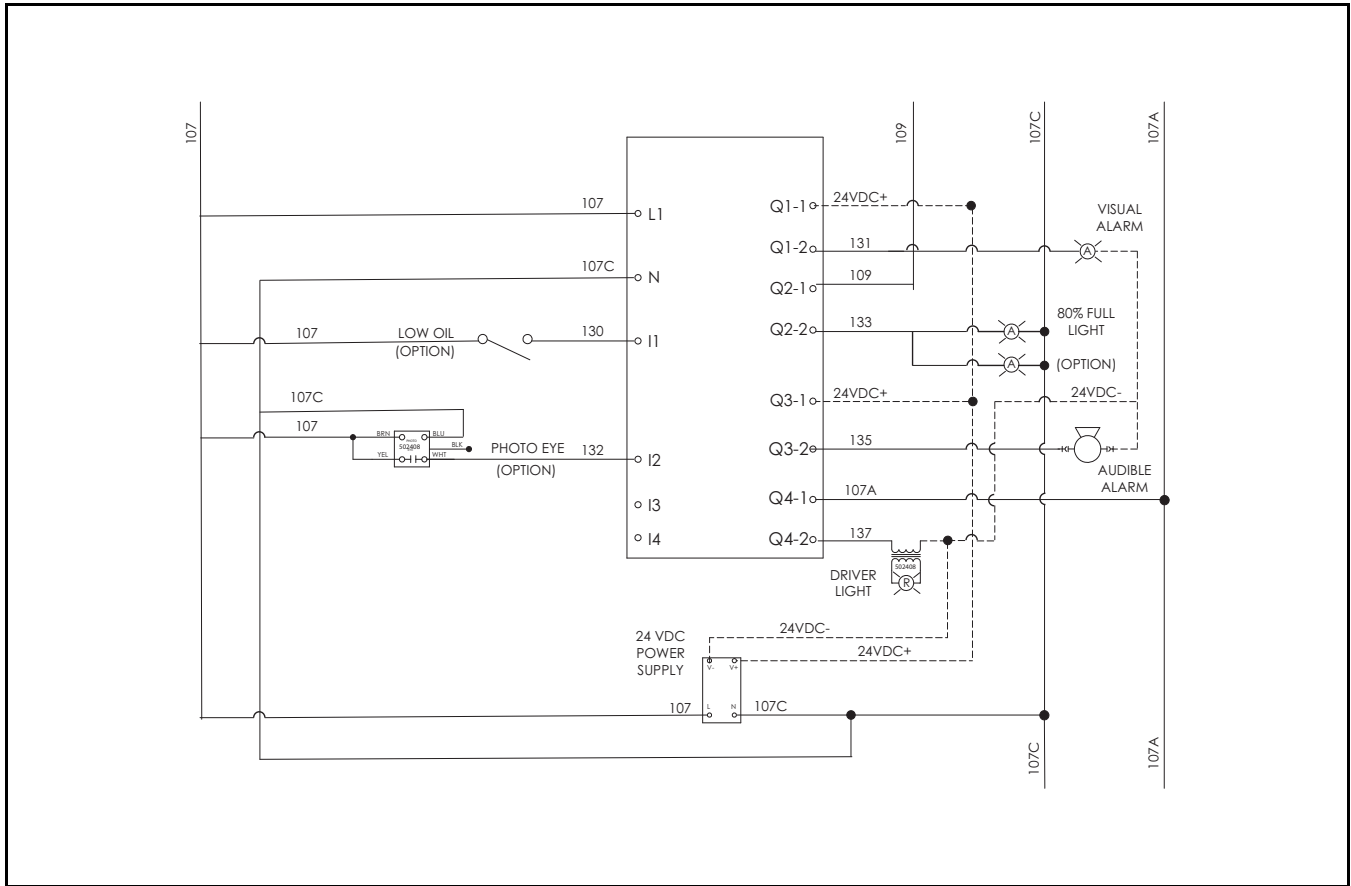

Section "C"

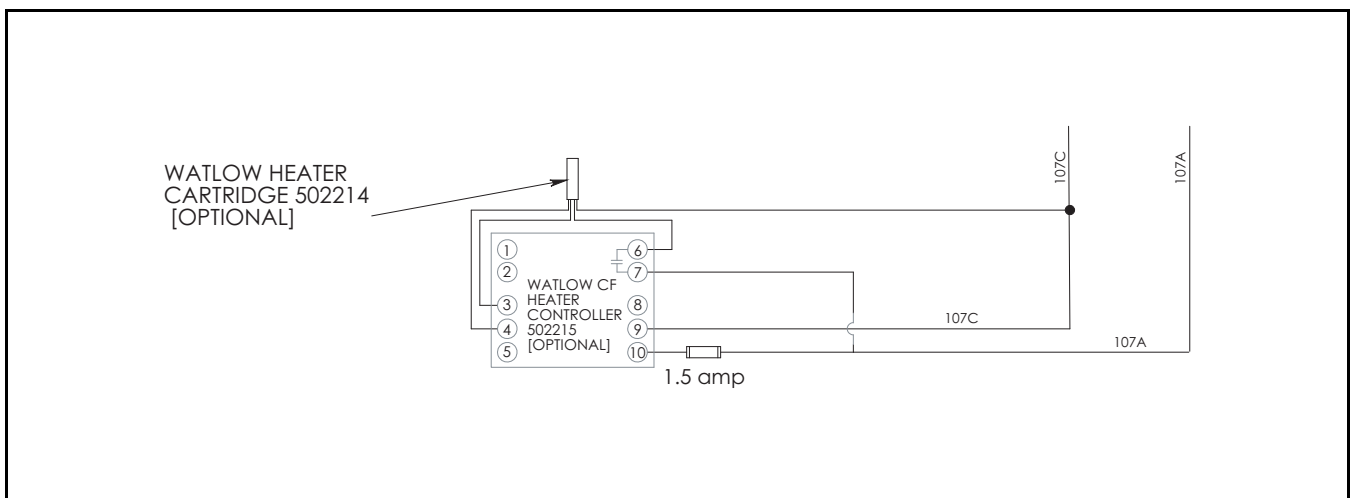

SCHEMATICS

HYDRAULIC SCHEMATIC

10HP, 3 PHASE, 60-HERTZ

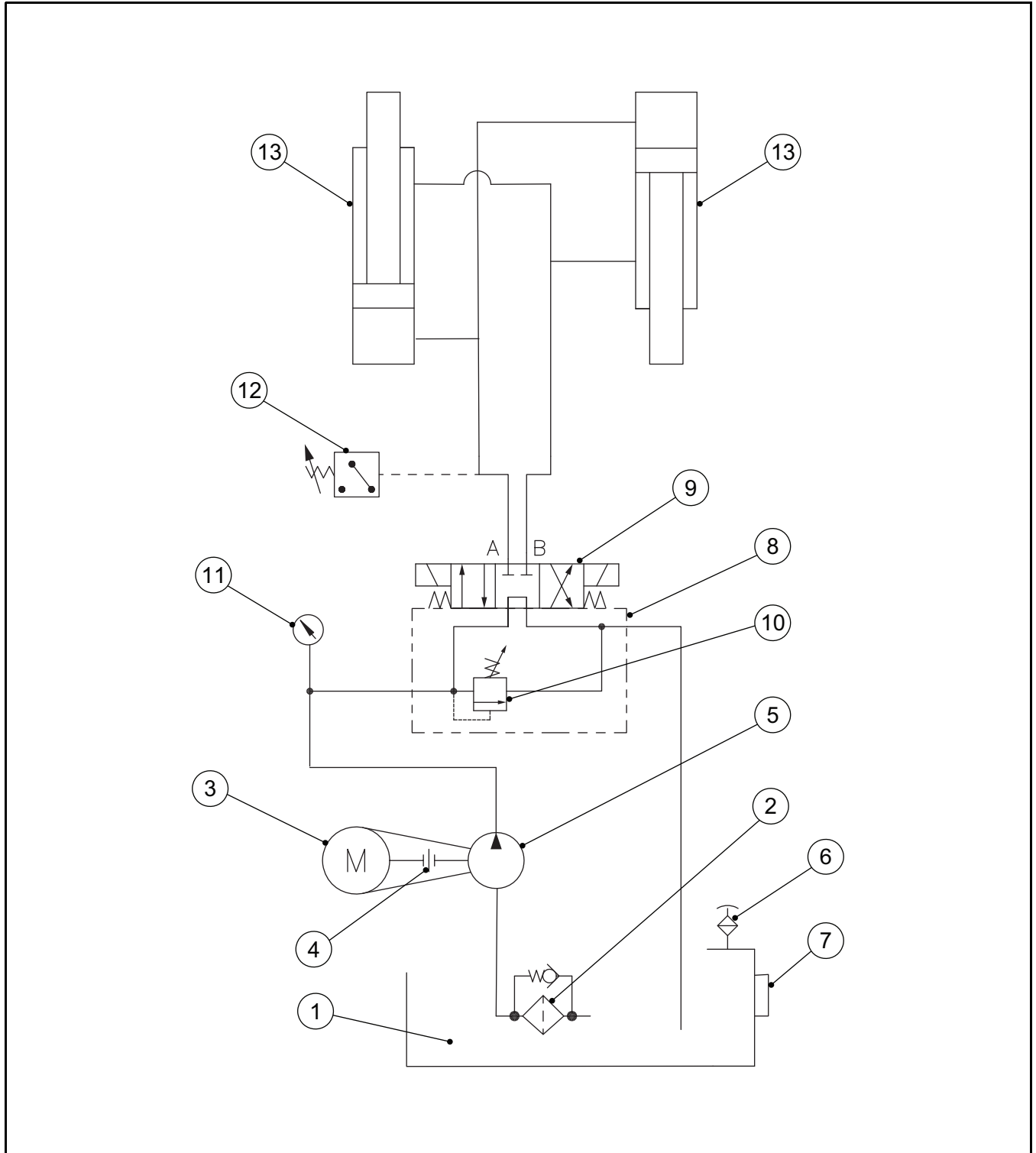

SCHEMATICS

HYDRAULIC SCHEMATIC**10HP, 3 PHASE, 60-HERTZ**

Item	Part Number	Qty	Description	Note
1	500864	1	RESERVOIR, 18 GAL	
2	502111	1	STRAINER	
3	501849	1	ELECTRIC MOTOR, 10 HP, 3 PHASE, 60 HERTZ	
4	503159	1	COUPLER, PUMP	
4	503160	1	SPIDER, JAW COUPLING	
4	503161	1	COUPLER, MOTOR	
5	503141	1	PUMP, GEAR, 12 GPM	
6	503148	1	BREATHER, FILTER	
7	503153	1	SITE GLASS, 5"	
8	503140	1	MANIFOLD	
9	503149	1	DIRECTIONAL VALVE	
10	500849	1	RELIEF VALVE, 2,100 PSI	
11	503147	1	PRESSURE GAGE	
12	500719	1	PRESSURE SWITCH, 1,850 PSI	
13	500405	2	RAM CYLINDER, BY-PASSING	

PARTS

OVERVIEW

Many features have been utilized in the Parts section. Facing pages have been used to ensure the illustration is displayed with the parts list. Descriptions are indented to indicate when the component is included with the assembly. Notes are used to provide additional information.

The following is a summary of the layout used for the parts list:

Item	Part Number	Qty	Description	Note
1	NSS	1	INDICATOR LAMP, 100% FULL, RED	
	502376	1	• HEAD ONLY, PILOT LIGHT, RED	
	502377	1	• COMPLETE LIGHT BODY, RED	N1
2	NSS	1	SELECTOR SWITCH, OFF/ON, KEYED	
	503134	1	• HEAD ONLY, KEYED SWITCH, STAY PUT	
	NSS	1	• CONTACT BLOCKS - SINGLE, NO	N2
N1	INCLUDES FIXING COLLAR AND LIGHT BLOCK WITH INTEGRAL LED			
N2	INCLUDES BODY/FIXING COLLAR			

Figure 40

Item (**Figure 40, 1**) is used to reference the callout and leader in the illustration of the facing page.

Part Number (**Figure 40, 2**) identifies a component or assembly part. A part number is used when the part can be ordered as a replacement. A part that is not available to be ordered is identified with **NSS** indicating the part is Not Serviced Separately.

Qty (**Figure 40, 3**) indicates the quantity required by its parent part number. In some situations the quantity required can vary. In these situations the quantity is not specified. The quantity is identified with **AR** indicating to use the quantity As Required.

Description (**Figure 40, 4**) describes the component or assembly part. The description will include information relative to size, type or application.

Bullets (**Figure 40, 5**) are used at the beginning of the Description to identify the indentation level for the Part Number. All Part Numbers with descriptions indented an additional level are included when ordering the Part Number with the previous indentation level.

Note (**Figure 40, 6**) is used to indicate when additional information is available for a Part Number. A Note is identified by a N1, N2, etc. The capital letter **N** indicates that it is a Note followed by a unique identifier number.

Notes are located at the bottom (**Figure 40, 7**) of the Parts Table using the identifier.

PARTS

CONTAINER

Door and Hinges Illustration

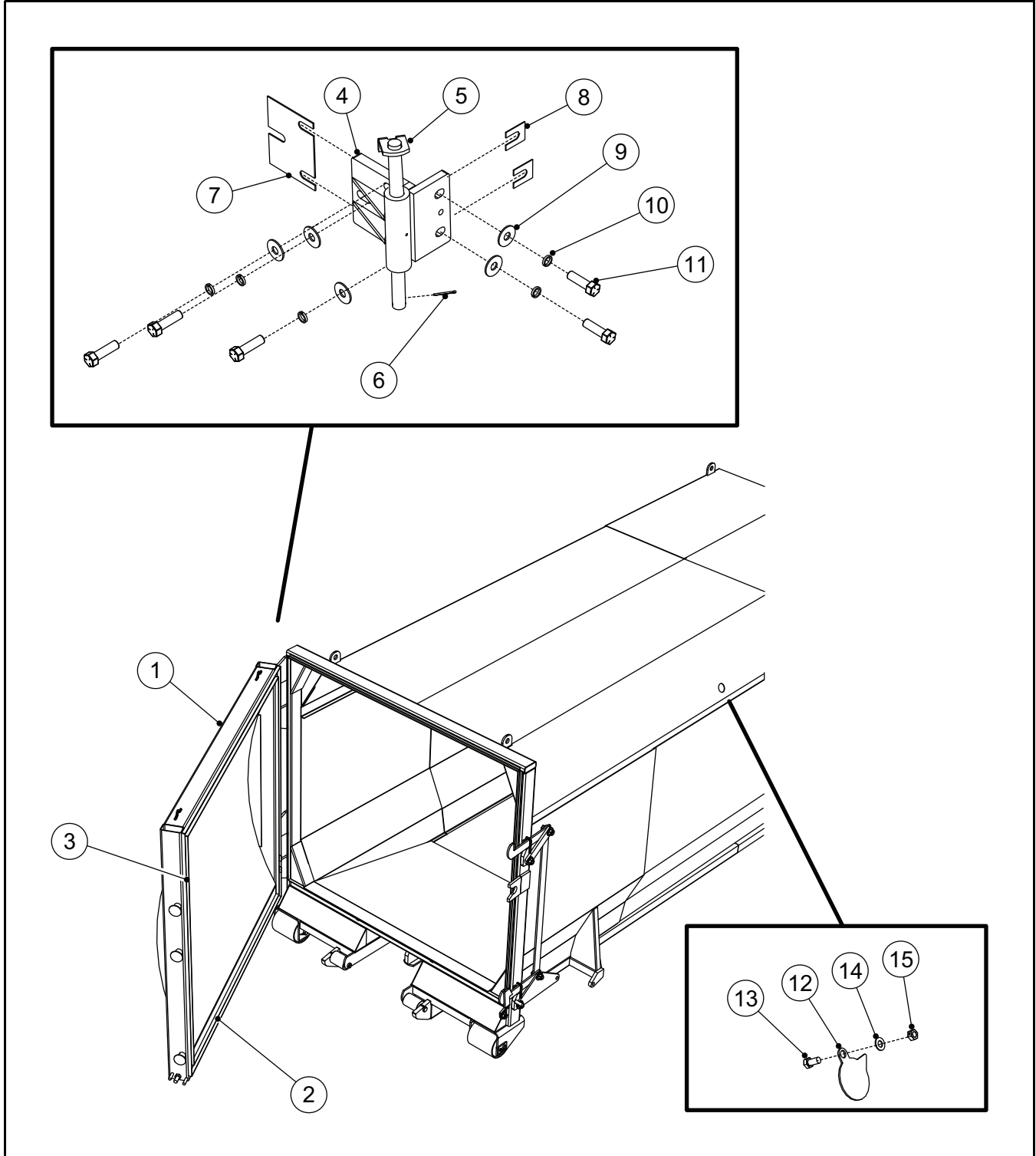

Reference: 500906

PARTS

CONTAINER

Door and Hinges Parts List

Item	Part Number	Qty	Description	Note
1	100016	1	DOOR WELDMENT, STANDARD	
1	501384	1	DOOR WELDMENT, LOW PROFILE	
2	502949	2	DOOR SEAL, HORIZONTAL, 80"	N1
3	502948	2	DOOR SEAL, VERTICAL, STANDARD, 93"	N1
3	502949	2	DOOR SEAL, VERTICAL, LOW PROFILE, 80"	N1
4	500711	2	DOOR HINGE	
5	500708	2	PIN, DOOR HINGE	
6	101042	2	COTTER PIN	
7	500707	AR	SHIM, SIDE	
8	500569	AR	SHIM, REAR	
9	100018	10	WASHER, FLAT	
10	101407	10	WASHER, SPLIT	
11	100016	10	BOLT, HHCS, .75-10 X 2.5, GR5	
12	500537	1	COVER, FIRE HOSE PORT	
13	100805	1	BOLT, JJCS, .5-13X1, GR5	
14	122196	1	WASHER, FLAT, .5, ZN	
15	100499	1	NUT, HEX, LOCK, REV, .5-13, ZN	
	501927	AR	GLUE, ADHESIVE SEALANT	N1
N1	GLUE (501927) REQUIRED WHEN INSTALLING DOOR SEALS			

PARTS

CONTAINER

Door Latch Linkage Illustration

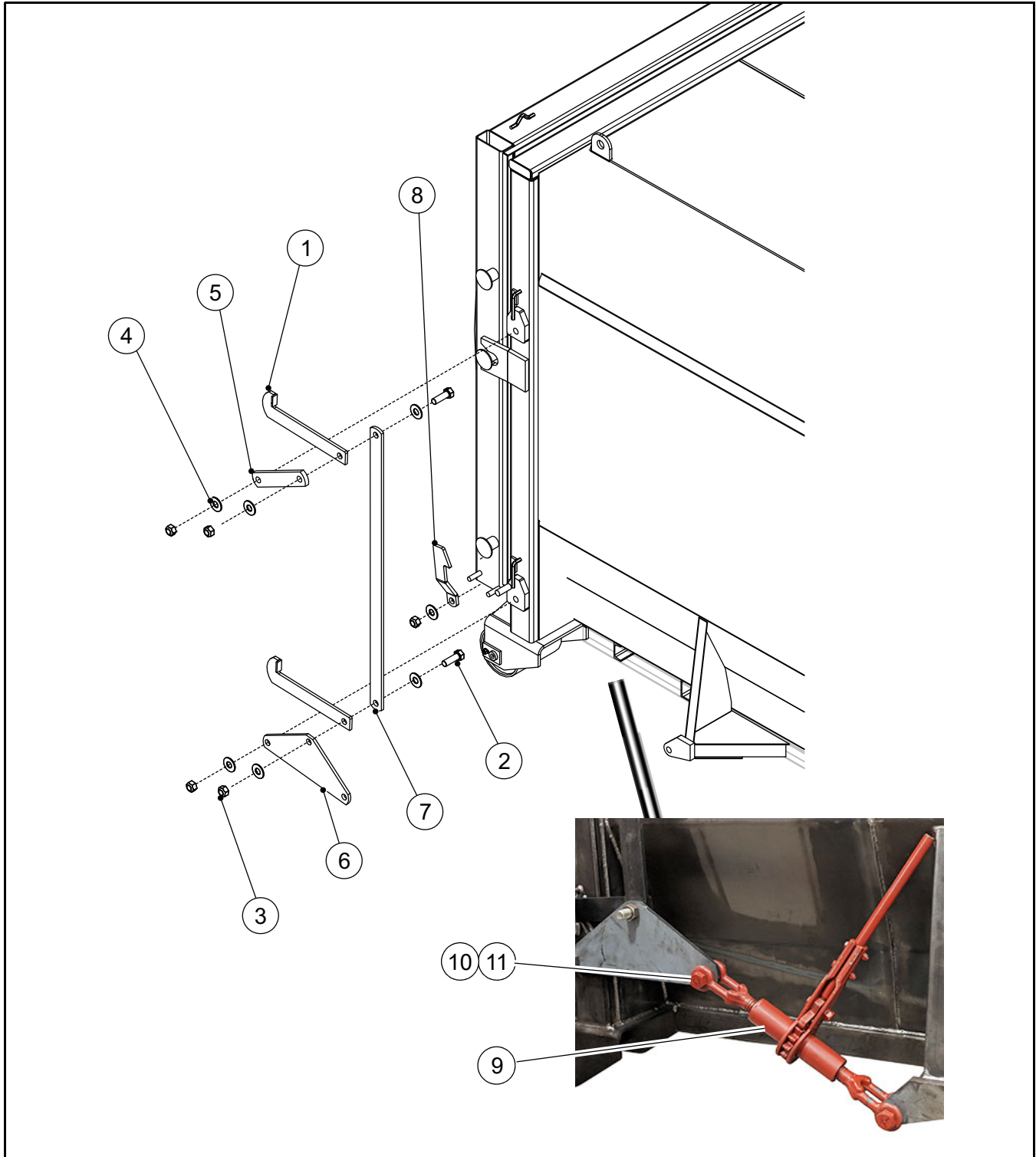

Reference: 500906

PARTS

CONTAINER

Door Latch Linkage Parts List

Item	Part Number	Qty	Description	Note
1	500572	2	LATCH, DOOR, KP2SC	
2	100571	2	BOLT, HHCS, 1-8X3, GR8	
3	101018	5	NUT, HEX, LOCK, TOP, 1-8, GR8, ZN	
4	111235	7	WASHER, FLAT, 1, USS, ZN	
5	500573	1	DOOR LINK, PLATE, KP2SC	
6	500574	1	PIVOT PLATE, KP2SC	
7	500575	1	CONNECTING LINK, PLATE, KP2SC	
8	500576	1	DOOR CATCH, PLATE,	
9	500717	1	TURNBUCKLE	
10	NSS	2	• BOLT	
11	NSS	2	• NUT	

PARTS

CHAMBER

Cover Plate, Rollers and Ram Blocks Illustration

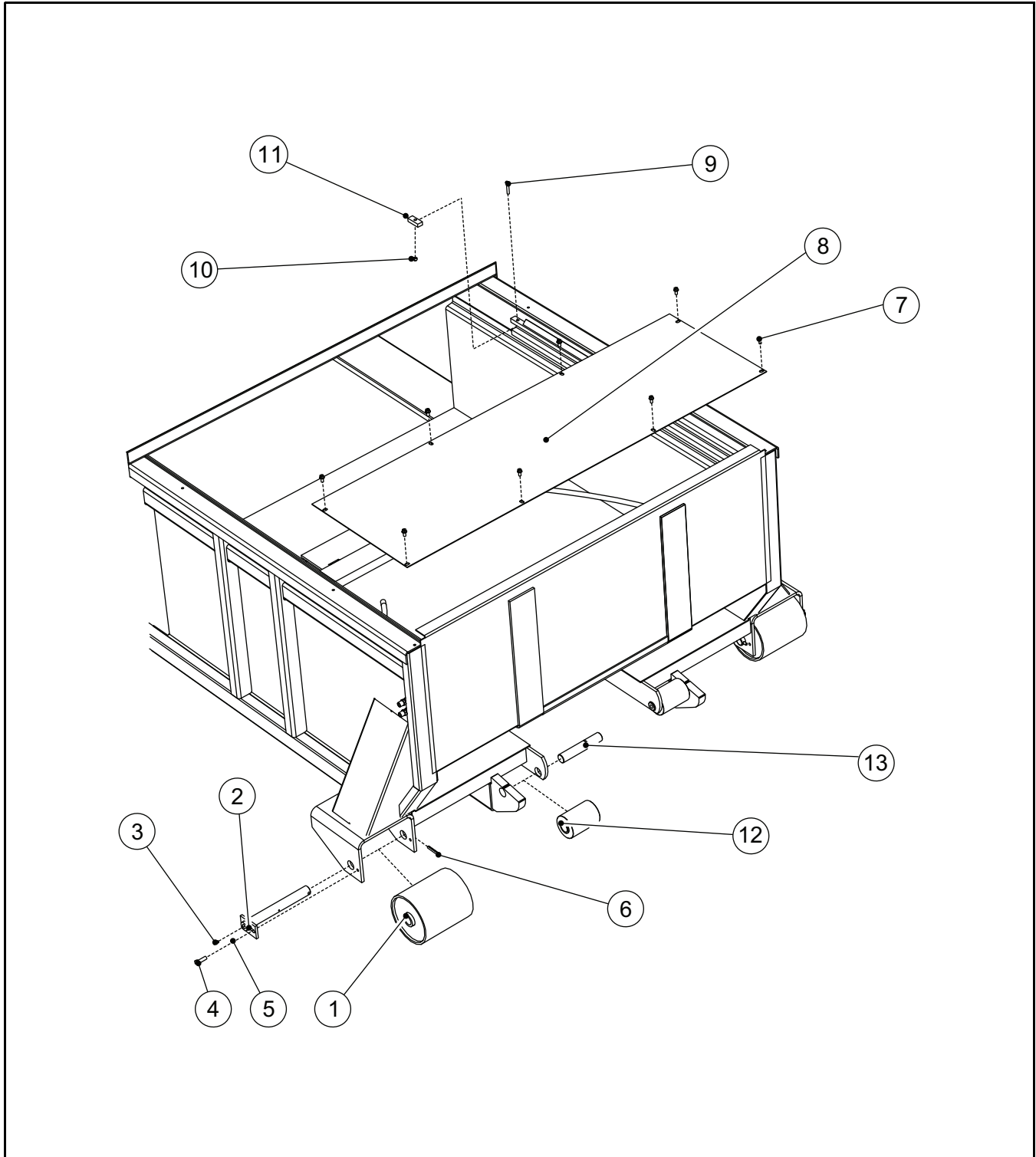

Reference: 500906

PARTS

CHAMBER

Cover Plate, Rollers and Ram Blocks Parts List

Item	Part Number	Qty	Description	Note
1	500581	4	FLOOR ROLLER WLDT, KP2SC	
2	500577	4	AXLE WLDT, KP2SC	
3	107154	4	GREASE ZERK, .125 NPT	
4	109547	4	BOLT, HHCS, .5-13X1.5, GR5, ZN	
5	113661	4	WASHER, SPLIT LOCK, .5, ZINC	
6	120713	4	ROLL PIN, SLOTTED, .375 X 2.5	
7	500051	8	SCREW, THD CUT, .375-16X.75, ZN	
8	500406	1	COVER, TOP, HEAD, KP2SC	
9	120094	2	BOLT, HHCS, .375-16X2, GR5, ZN	
10	120945	2	NUT, HEX, LOCK, TOP, .375-16, ZN	
11	500430	2	STOP, .625X1X2.5, KP2SC	
12	500475	4	NOSE ROLLER, KP2SC	
13	500476	4	AXLE, ROLLER, KP2SC	

PARTS

CHAMBER

Ram and Follower Assembly Illustration

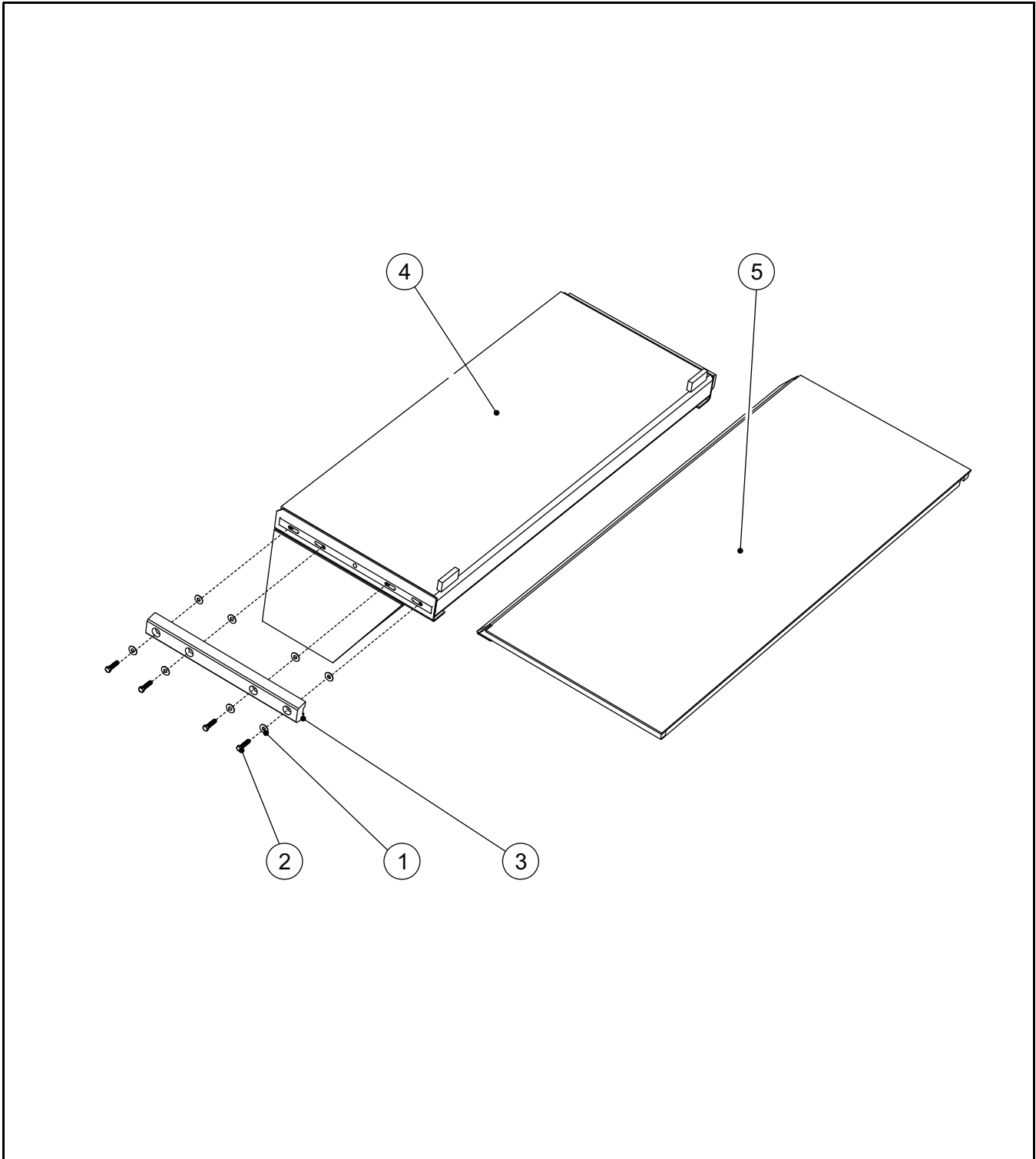

Reference: 500906

PARTS

CHAMBER

Ram and Follower Assembly Parts List

Item	Part Number	Qty	Description	Note
1	113018	16	WASHER, .50, ZINC PLATE	
2	122298	8	BOLT, HHCS, .5-13X2, GR8, ZN&YL	
3	500886	2	SLIDE BLOCK, UHMW	
4	500424	1	RAM PACK PANEL WLDT, KP2SC	
5	500451	1	SLIDE COVER WLDT, KP2SC	

PARTS

CHAMBER

Ram Cylinders and Mounting Illustration

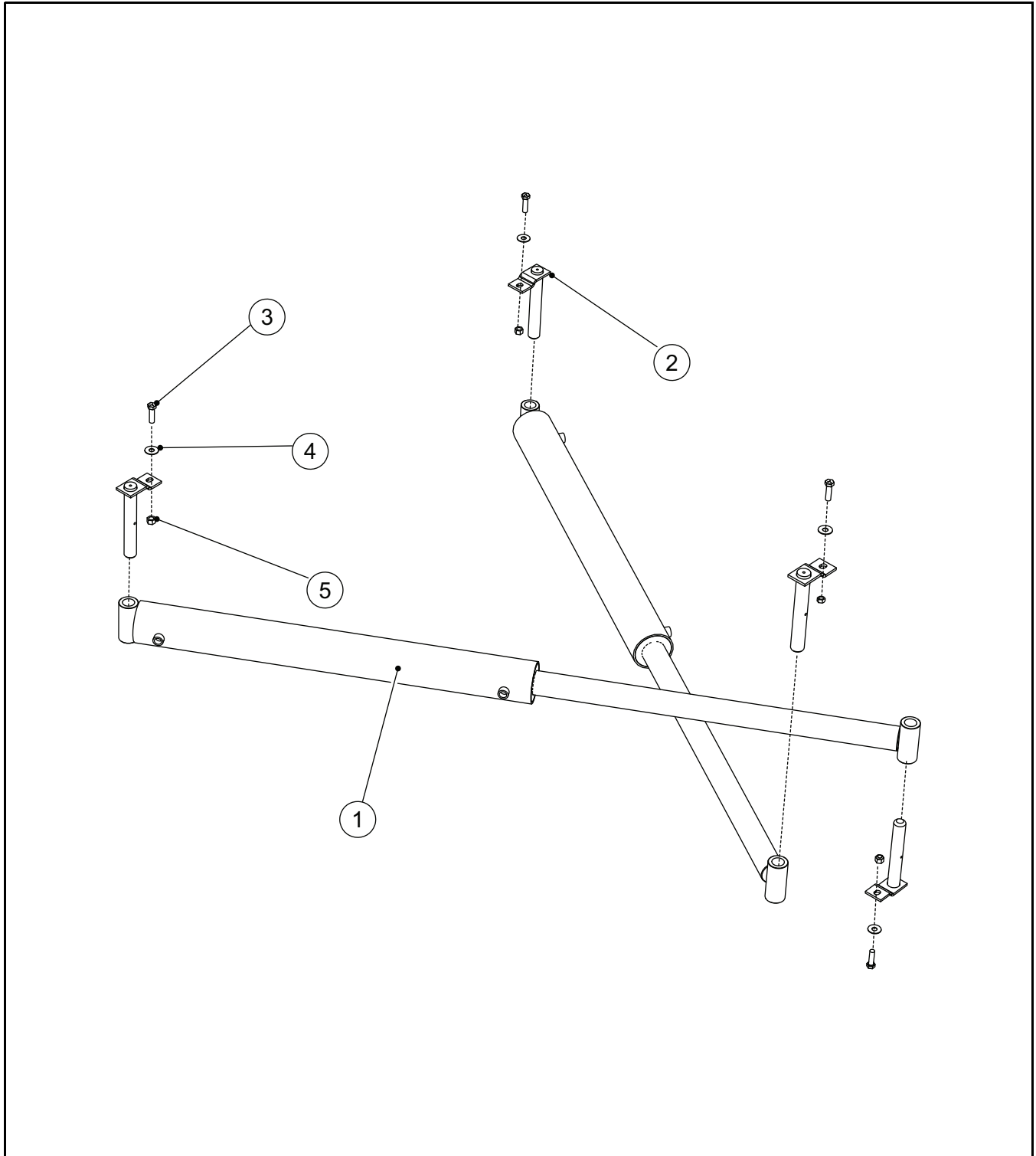

Reference: 500906

PARTS

CHAMBER

Ram Cylinders and Mounting Parts List

Item	Part Number	Qty	Description	Note
1	500405	2	RAM CYLINDER, 4X37, BY-PASS	
2	500411	4	PIN, WELDMENT, CYLINDER	
3	120944	4	BOLT, HHCS, .5-13X1.75, GR 5	
4	113018	4	WASHER, .5, ZINC PLATE	
5	120946	4	NUT, HEX, LOCK, TOP, .5-13, ZN	

PARTS

CHAMBER

Ram Cylinder Hydraulics Illustration

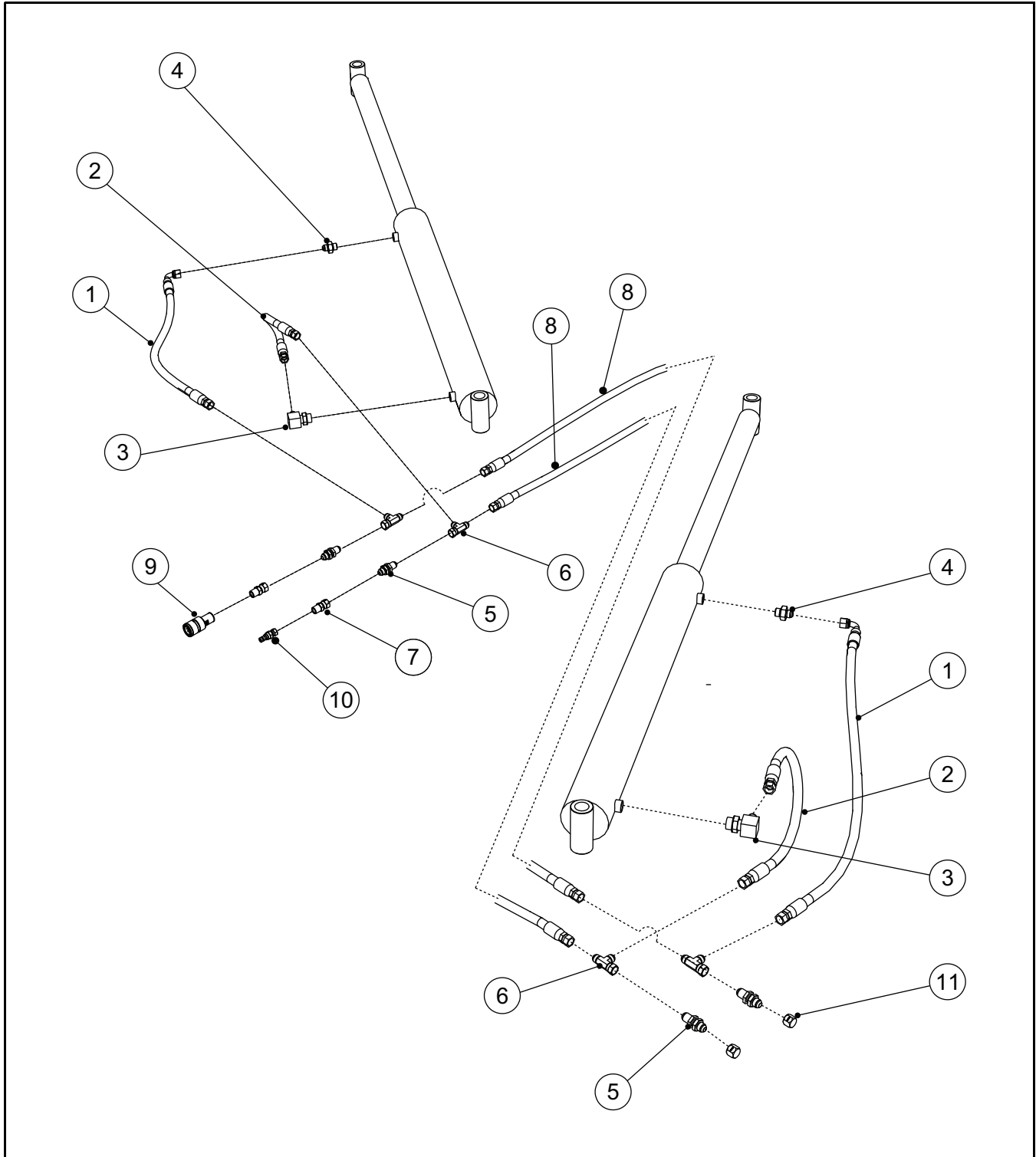

Reference: 500906

PARTS

CHAMBER

Ram Cylinder Hydraulics Parts List

Item	Part Number	Qty	Description	Note
1	502952	2	HOSE ASSY, 45", H3008-08FX0N-08FX0N-45	
2	502951	2	HOSE ASSY, 29", H3008-08FX0N-08FX0N-29	
3	100108	2	ELBOW 90°, JIC TO O-RING, 8MJ-12MO-9N	
4	102290	2	ADAPTER, JIC TO O-RING, 8MJ-12MO-0N	
5	101081	4	BULKHEAD UNION W/ LOCKNUT, JIC, 8MJ-8BH-0N	
6	101104	4	SWIVEL RUN TEE, JIC, 8MJ-8FX-8MJ-RN	
7	109926	2	ADAPTER, JIC TO PIPE, 8MP-8FX-ON	
8	502950	2	HOSE ASSY, 66", H3008-08FXON-66-2	
9	105811	1	QUICK DISCONNECT FEMALE COUPLER, .5 NPT, 4250-4	
10	109926	1	QUICK DISCONNECT MALE NIPPLE, .5 NPT, 8010-4	
11	110912	2	CAP, JIC, 8FJ-C	

PARTS

CONTROL PANEL

Panel Cover Illustration

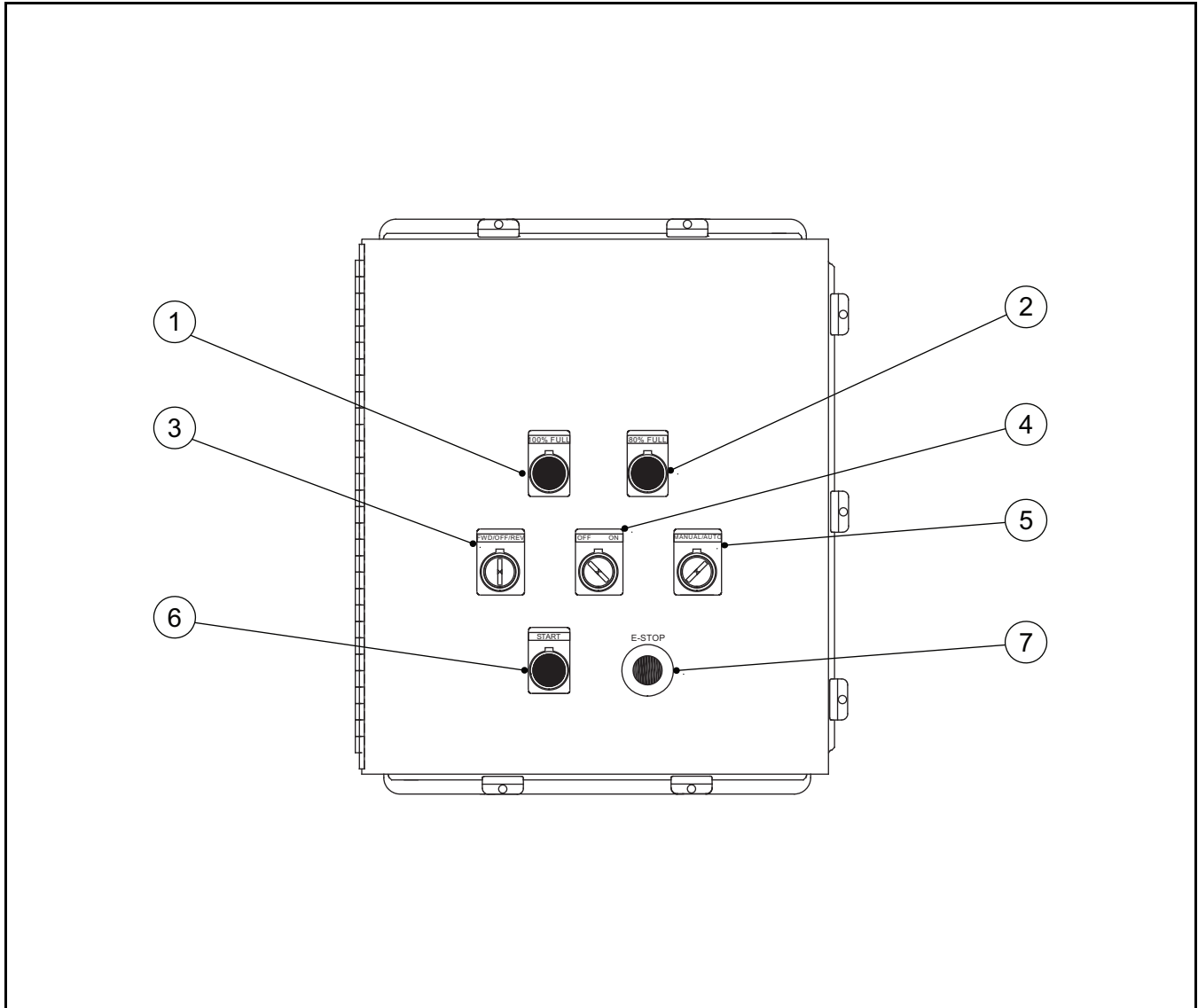

Reference: 500301 500305 502212

Item	Part Number	Qty	Description	Note
1	NSS	1	INDICATOR LAMP, 100% FULL, RED	
	502376	1	• HEAD ONLY, PILOT LIGHT, RED	
	502377	1	• COMPLETE LIGHT BODY, RED	N1
2	NSS	1	INDICATOR LAMP, 80% FULL, ORANGE	
	503833	1	• HEAD ONLY, PILOT LIGHT, ORANGE	
	502471	1	• COMPLETE LIGHT BODY, ORANGE	N1

PARTS

CONTROL PANEL

Panel Cover Parts List

Item	Part Number	Qty	Description	Note
3	NSS	1	3-POSITION SWITCH, FWD/OFF/REV	
	132785	1	• HEAD ONLY, SELECTOR SWITCH, SPRING RETURN	
	NSS	1	• CONTACT BLOCKS - DOUBLE, NO	N2
	127244	1	•• BODY/FIXING COLLAR	
	123551	2	•• SINGLE CONTACT BLOCK, NO	
4	NSS	1	SELECTOR SWITCH, OFF/ON, KEYED	
	503134	1	• HEAD ONLY, KEYED SWITCH, STAY PUT	
	NSS	1	• CONTACT BLOCKS - SINGLE, NO	N2
	127244	1	•• BODY/FIXING COLLAR	
	123551	1	•• SINGLE CONTACT BLOCK, NO	
5	NSS	1	SELECTOR SWITCH, MANUAL/AUTO	
	503135	1	• HEAD ONLY, SELECTOR SWITCH, STAY PUT	
	NSS	1	• CONTACT BLOCKS - DOUBLE, NO/NC	N2
	127244	1	•• BODY/FIXING COLLAR	
	123551	1	•• SINGLE CONTACT BLOCK, NO	
	123328	1	•• SINGLE CONTACT BLOCK, NC	
6	NSS	1	PUSH BUTTON, START, GREEN, FLUSH	
	502469	1	• HEAD ONLY, PUSH BUTTON, GREEN	
	NSS	1	• CONTACT BLOCK - SINGLE, NO	N2
	127244	1	•• BODY/FIXING COLLAR	
	123551	1	•• SINGLE CONTACT BLOCK, NO	
7	NSS	1	MUSHROOM-HEADED, E-STOP, PUSH BUTTON	
	503136	1	• HEAD ONLY, EMERGENCY SWITCH, RED	
	NSS	1	• CONTACT BLOCKS - DOUBLE, NC	N2
	127244	1	•• BODY/FIXING COLLAR	
	123328	2	•• SINGLE CONTACT BLOCK, NC	
	110834	1	• LEGEND, CIRCULAR YELLOW, EMERGENCY STOP	
N1	INCLUDES FIXING COLLAR AND LIGHT BLOCK WITH INTEGRAL LED			
N2	INCLUDES BODY/FIXING COLLAR			

PARTS

CONTROL PANEL

Inside Panel Illustration

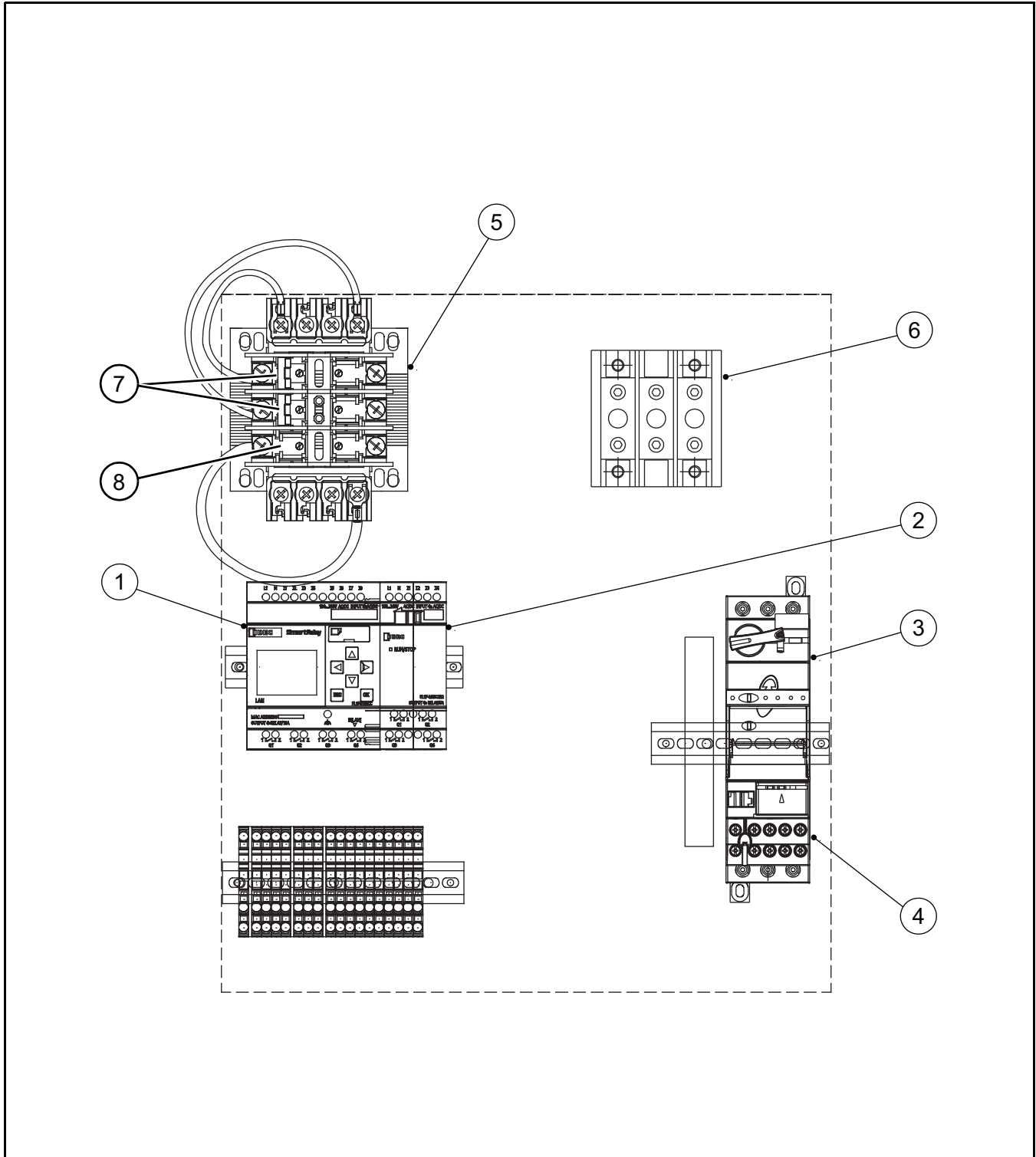

Reference: 500301 500305 502212

PARTS

CONTROL PANEL

Inside Panel Parts List

Item	Part Number	Qty	Description	Note
1	502345	1	PROGRAMMABLE RELAY (SMART)	
2	502373	1	EXPANSION I/O MODULE	
3	511003	1	MODULE, MOTOR STARTER POWER BASE	
4	502266	1	MODULE, OVERLOAD	
5	503137	1	CONTROL TRANSFORMER, 150VA, 208/230/460 VAC	
6	503138	1	POWER DISTRIBUTION BLOCK	
7	503059	2	FUSE, 1-1/2 AMP, 600V	
8	503139	1	FUSE, MIDGET, 3 AMP, 250V	

PARTS

POWER PACK

Assembly Illustration

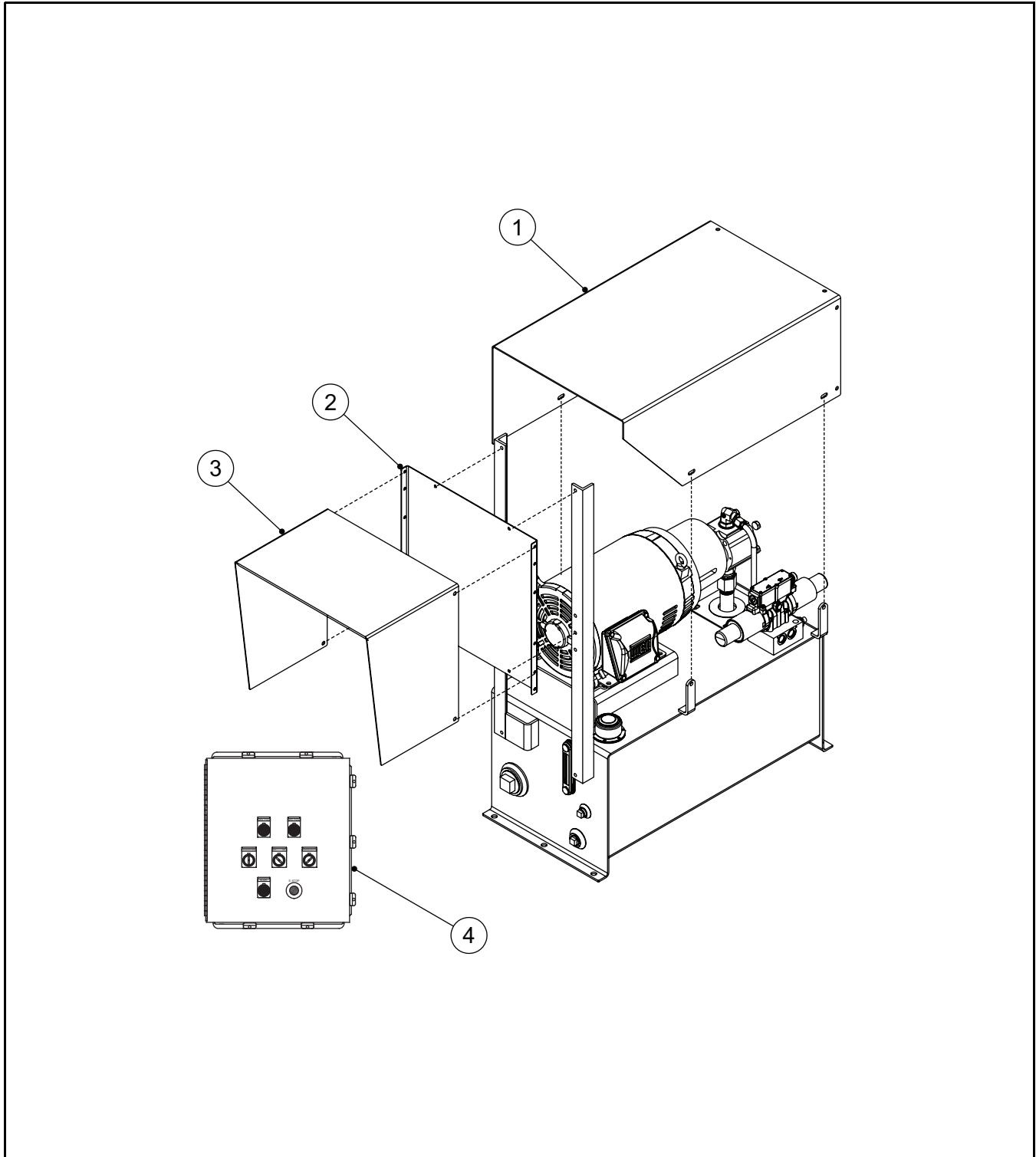

Reference: 501261

PARTS

POWER PACK

Assembly Parts List

Item	Part Number	Qty	Description	Note
1	500580	1	COVER, MOTOR AND PUMP	
2	500769	1	BACK PLATE	
3	500768	1	COVER, CONTROL PANEL	
4	502212	1	CONTROL PANEL ASSY, 208 VAC, 10 HP, THREE PHASE	
4	500301	1	CONTROL PANEL ASSY, 230 VAC, 10 HP, THREE PHASE	
4	500305	1	CONTROL PANEL ASSY, 460 VAC, 10 HP, THREE PHASE	

PARTS

POWER PACK

Hydraulic Reservoir Illustration

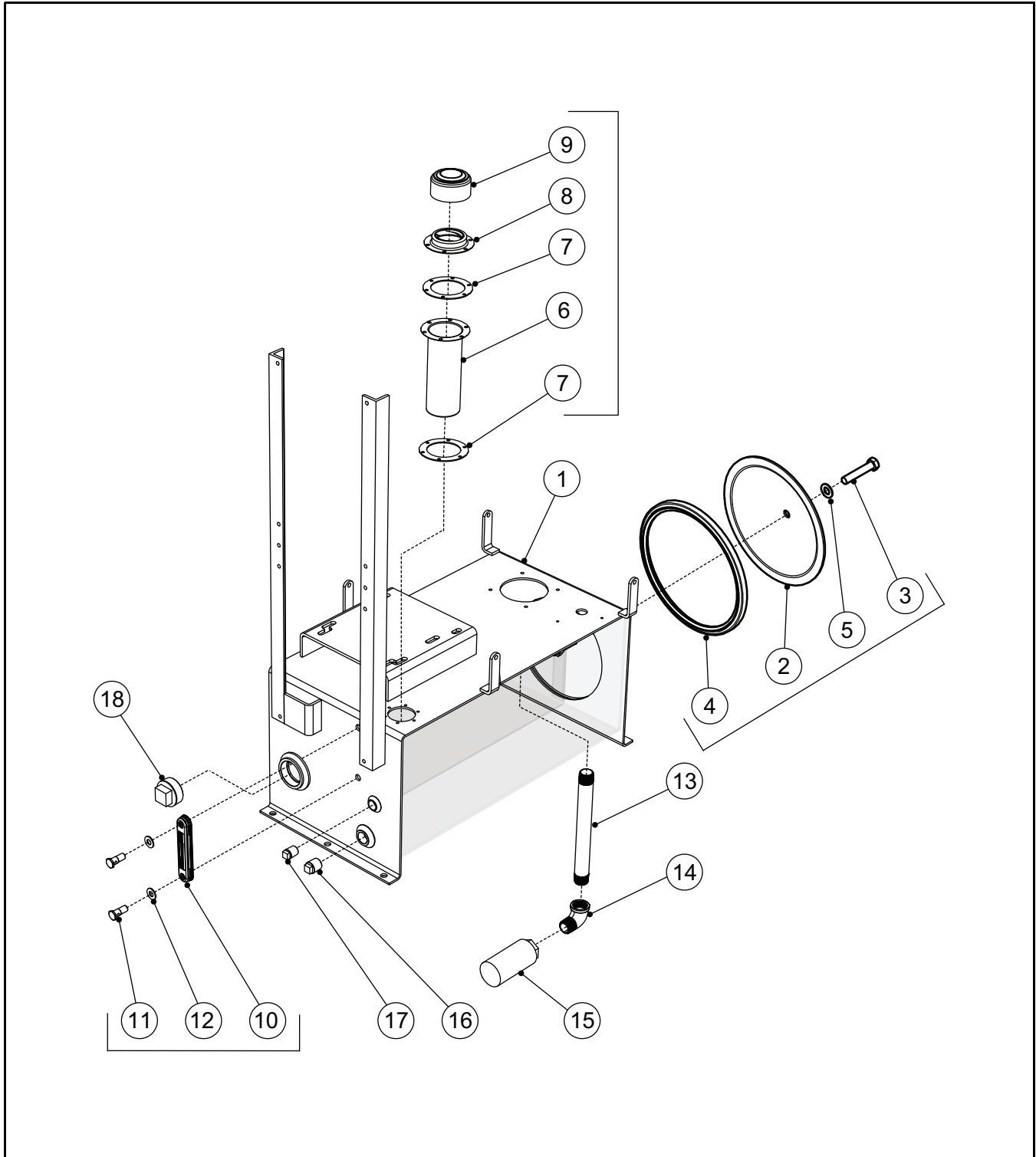

Reference: 501261

PARTS

POWER PACK

Hydraulic Reservoir Parts List

Item	Part Number	Qty	Description	Note
1	502345	1	RESERVOIR, W/C	
	503153	1	CLEAN-OUT COVER ASSY	N1
2	NSS	1	• COVER, CLEAN-OUT	
3	NSS	1	• BOLT, .625 UNC X 3	
4	NSS	1	• GASKET, CLEAN-OUT COVER	
5	NSS	1	• WASHER, FLAT, .625	
	503148	1	FILLER, STRAINER AND BREATHER ASSY, 6", 40 MICRON	N2
6	NSS	1	• BASKET, STAINLESS	
7	NSS	2	• GASKET, CORK	
8	NSS	1	• FLANGE	
9	NSS	1	• CAP, BREATHER	
	503153	1	LEVEL/TEMP GAUGE ASSY	N3
10	NSS	1	• LEVEL/TEMP GAUGE	
11	NSS	2	• HOLLOW BOLT, .5-13 UNC X 1.75"	F4
12	NSS	2	• WASHER	
13	500921	1	NIPPLE, PIPE, 1" NPT X 12"	
14	124549	1	90° STREET ELBOW, PIPE, 1" NPT	
15	502111	1	SUCTION FILTER	
16	108881	1	PLUG, MAGNETIC, PIPE, 3/4" NPT	
17	501260	1	PLUG, PIPE, 1/2" NPT	
18	102765	1	PLUG, PIPE, 2" NPT	
N1	INCLUDES ITEMS 3, 4, 5 AND 6			
N2	INCLUDES ITEMS 6, 7, 8 AND 9			
N3	INCLUDES ITEMS 10, 11 AND 12			
N4	MAX TIGHTENING TORQUE SUGGESTED 4 FT-LBS			

PARTS

POWER PACK

Pump Hydraulics Illustration

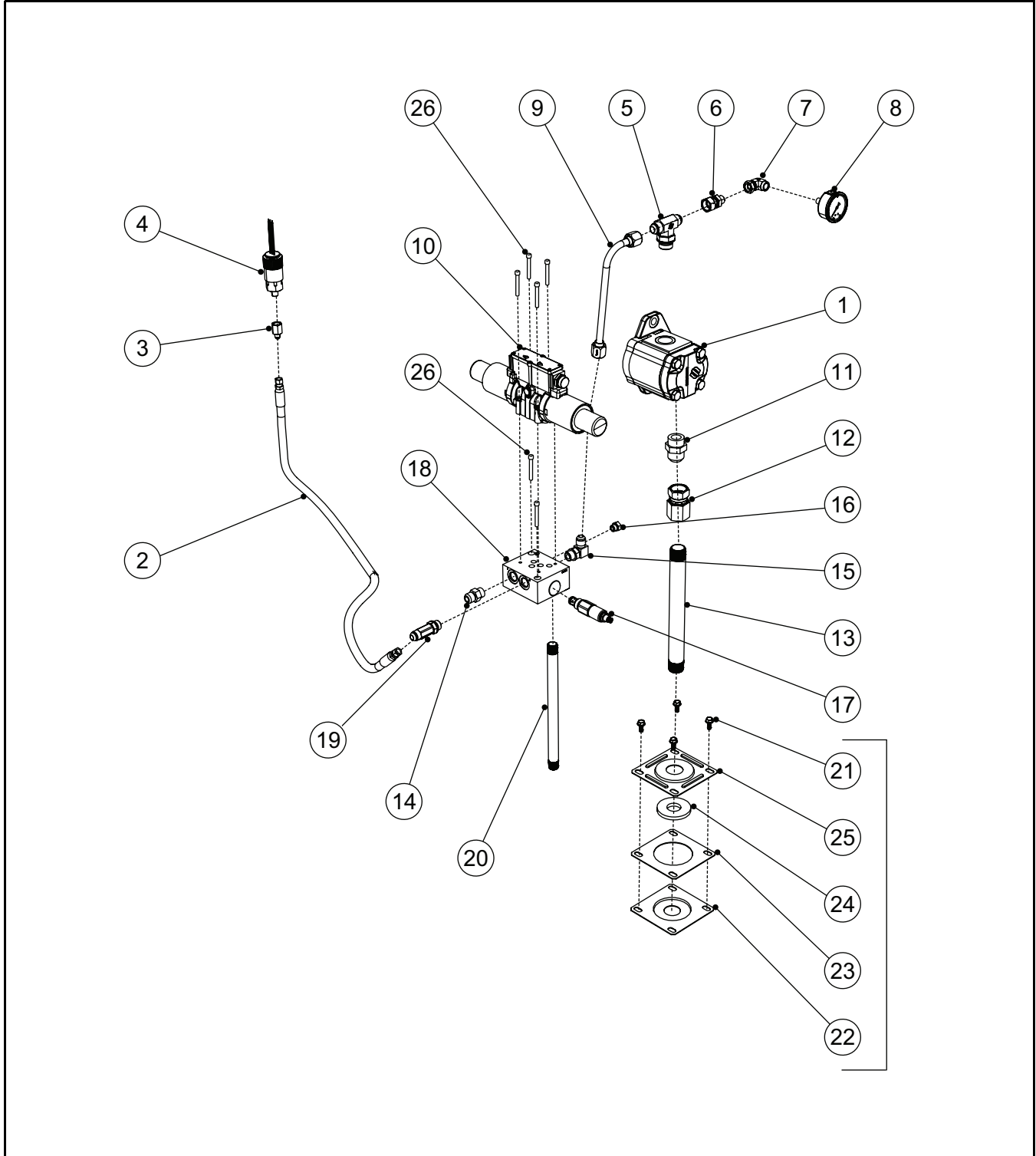

Reference: 501261

PARTS

POWER PACK

Pump Hydraulics Parts List

Item	Part Number	Qty	Description	Note
1	503141	1	PUMP, GEAR	
2	503155	1	HOSE ASSY, 46", H3004-04FX0N-04FX0N-46	
3	106401	1	ADAPTER, JIC TO PIPE, 4MJ-4FP-0N	
4	500719	1	PRESSURE SWITCH	
5	503144	1	BRANCH TEE, JIC TO O-RING, 10MJ-10MJ-12MO-TN	
6	503145	1	ADAPTER, JIC SWIVEL TO PIPE, 10FX-6MP-0N	
7	503146	1	ADAPTER, 90° SWIVEL ELBOW, PIPE TO PIPE, 4FP-6FX-9N	
8	503147	1	GAUGE, PRESSURE	
9	503143	1	TUBE ASSY, PRESSURE	
10	503149	1	VALVE ASSY	
11	100100	1	ADAPTER, JIC TO O-RING, 16MJ-16MO-0N	
12	110968	1	ADAPTER, JIC SWIVEL TO PIPE, 16FX-16FP-0N	
13	503142	1	PIPE, SUCTION, 12 IN	
14	101098	1	ADAPTER, JIC TO O-RING, 8MJ-8MO-0N	
15	101113	1	ADAPTER, 90° ELBOW, JIC TO O-RING, 8MJ-8MO-9N	
16	107610	1	PLUG, O-RING, 6MO-P-HH	
17	500849	1	VALVE, RELIEF, 3,000 PSI	
18	503140	1	MANIFOLD, VALVE	
19	503154	1	RUN TEE, JIC TO O-RING, 8MJ-8MO-4MJ-RN	
20	503150	1	PIPE, RETURN, 12"	
	501850	1	SUCTION FLANGE ASSY, 1" PIPE	N1
21	NSS	1	• BOLT, HEX HEAD, .312-18 UNC X 1, ZN	
22	NSS	1	• BASE PLATE	
23	NSS	1	• GASKET, CORK	
24	NSS	1	• SEAL, RUBBER	
25	NSS	2	• TOP PLATE	
26	112607	6	SCREW, SOCKET HEAD, .25-20 X 2	
N1	INCLUDES ITEMS 21, 22, 23, 24 AND 25			

PARTS

POWER PACK

Motor and Pump Illustration

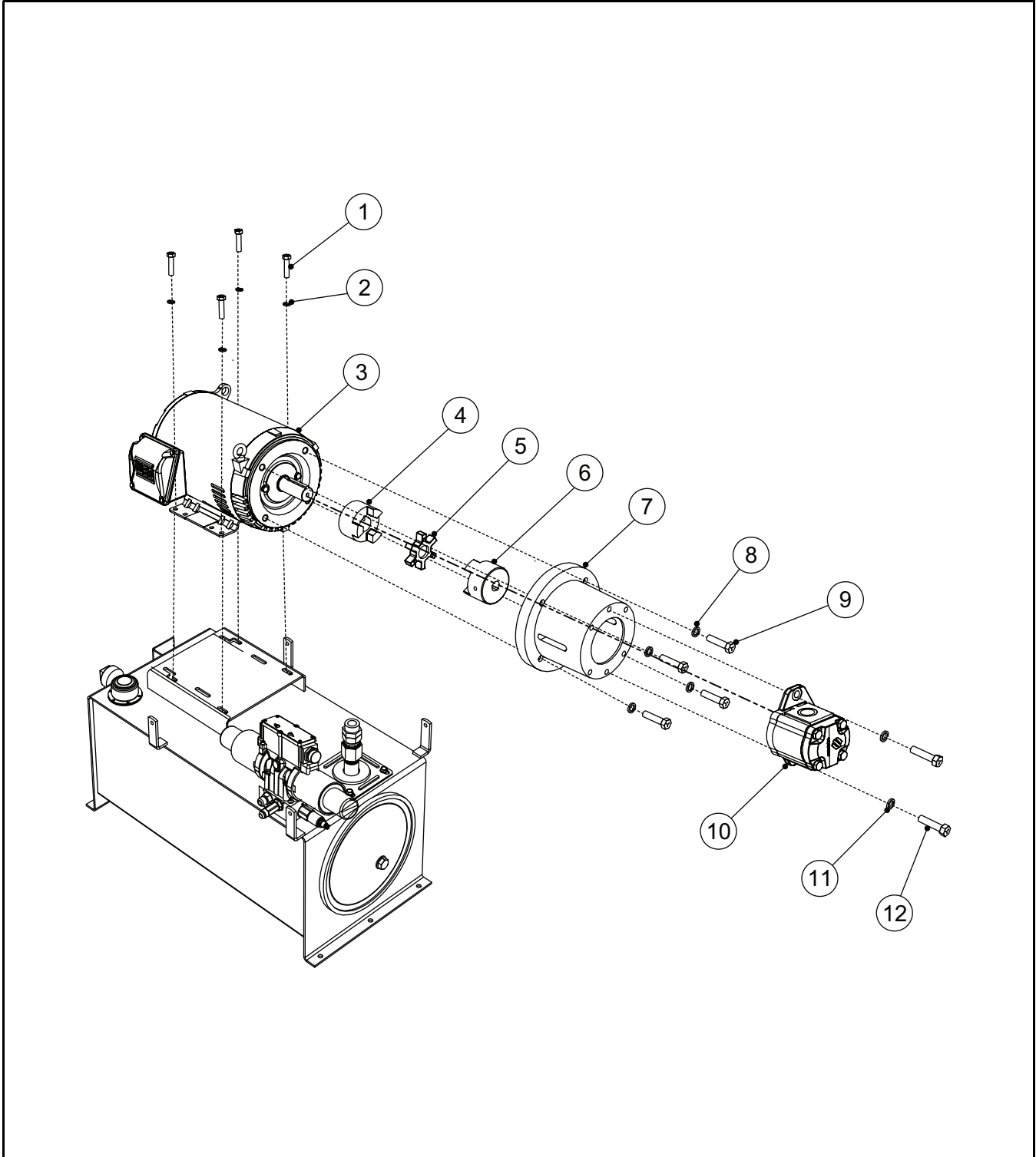

Reference: 501261

PARTS

POWER PACK

Motor and Pump Parts List

Item	Part Number	Qty	Description	Note
1	113241	4	BOLT, HHCS, .375-16 X 1.5, GR5, ZN	
2	104661	4	WASHER, LOCK-SPLIT, .375, ZN	
3	501849	1	MOTOR, ELECTRIC, 3 PHASE, 10 HP	
4	503161	1	COUPLER, MOTOR	
5	503160	1	SPIDER, COUPLER	
6	503159	1	COUPLER, PUMP	
7	503151	1	ADAPTER, MOTOR/PUMP, 10 HP	
8	100498	4	WASHER, LOCK, SPLIT, .5	
9	121464	4	BOLT, HHCS, .5-13 X 2, GR5, ZN	
10	503141	1	PUMP, GEAR	
11	100498	2	WASHER, LOCK, SPLIT, .5	
12	121464	2	BOLT, HHCS, .5-13X2, GR5, ZN	

PARTS

This Page Intentionally Left Blank