

OWNER'S MANUAL

VERSION 2.0

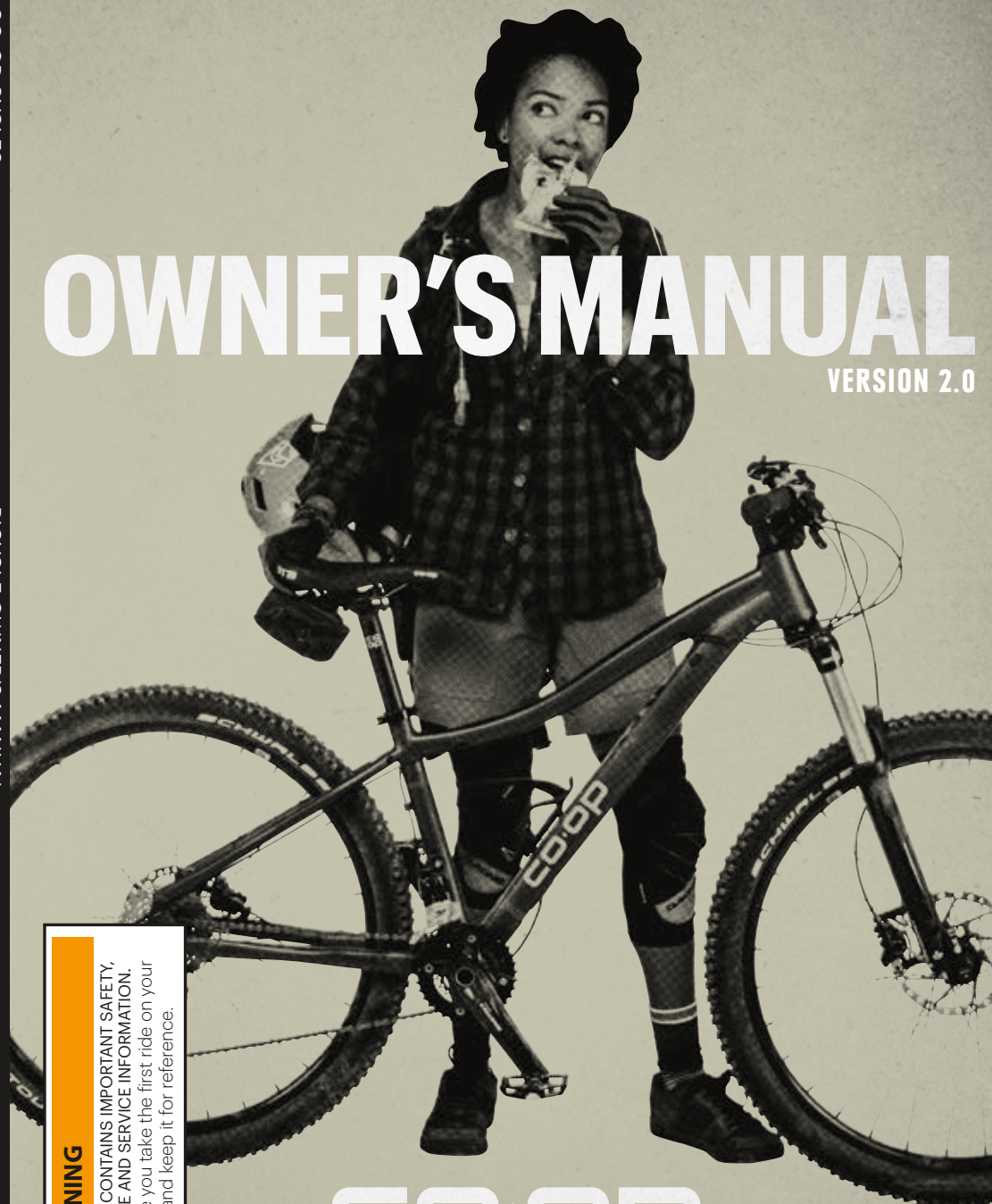

WARNING

THIS MANUAL CONTAINS IMPORTANT SAFETY, PERFORMANCE AND SERVICE INFORMATION. Read it before you take the first ride on your new bicycle, and keep it for reference.

CO-OP
CYCLES

CONGRATULATIONS ON YOUR PURCHASE OF A CO-OP CYCLES BICYCLE

ABOUT US:

Co-op Cycles is a trademark of Recreational Equipment, Inc. (REI).
Co-op Cycles are manufactured and distributed exclusively by REI.

100% SATISFACTION GUARANTEE

We stand behind everything we sell. If you are not satisfied with your REI purchase, you can return it for a replacement or refund. Items must be returned within a year of purchase, except items purchased from REI-OUTLET.com, which must be returned within 30 days of purchase.

LIMITED WARRANTY

If your item has a manufacturing defect in its materials or workmanship, you can return it at any time.

USEFUL LIFE

Nothing lasts forever, including your bike. When the useful life of your bike or its components is over, continued use is hazardous. Every Co-op Cycles frame and the components attached to the frame have a finite, limited useful life. **ALL CO-OP CYCLES FRAMES AND COMPONENTS SHOULD BE PERIODICALLY CHECKED BY AN REI OR OTHER PROFESSIONAL BICYCLE MECHANIC** for signs of wear, damage, stress and/or other potential points of failure. The frequency of these checks is affected by frequency of use, environmental considerations, bicycle type, riding style, rider weight, riding conditions and other factors. Please contact us for additional information.

CONTACT US

PHONE:

From the U.S. and Canada: 1-800-426-4840
International: 1-253-891-2500 (English language only)
Fax: 1-253-891-2523

ONLINE:

REI.com

RETAIL STORES:

To learn which REI retail location will best serve your needs, please visit [REI.com/stores](https://www.rei.com/stores) or call the Contact Center.

USE OF THIS MANUAL

Co-op Cycles Bicycle Owner's Manual

This manual contains important information affecting your safety and the proper use of bicycles. It is a very important manual for every bike we make. It is organized into two parts:

PART I

Is a generic guide to the proper function and use of bicycles. This generic information is used by many bike companies. Most aspects of bicycles are common or "generic."

PART II

Contains information specific to Co-op Cycles and topics we feel you need to know and understand about our bikes.

A manual alone cannot teach you how to ride, and a manual the size of an encyclopedia could not cover every combination of bicycle, rider and conditions. Thus, as a reasonable person would expect the Co-op Cycles' manuals and supplements focus on the bicycle, not teaching you to ride.

This manual is not intended as a comprehensive use, service, repair or maintenance manual. It contains no assembly instructions. This manual is not a service manual for any parts of your bike. Please see REI for all service, repairs or maintenance. REI can refer you to classes or books on bicycle use and maintenance.

Owner's Manual Supplements

Co-op Cycles Owner's Manual Supplements are "supplements" to this manual providing important additional model-specific safety, maintenance and technical information. Co-op Cycles Owner's Manual Supplements are not replacements for this or any other manual for your bike.

You can download Adobe Acrobat PDF versions of any Co-op Cycles Owner's Manual or Owner's Manual Supplements or Tech Notes from our website. Go to: <http://www.coopcycles.com>.

Other Manuals & Instructions

Many of the components on your bike were not made by Co-op Cycles. When available from the manufacturer, Co-op Cycles packages these manuals and/or instructions with our bikes for delivery to you. We strongly recommend that you read and follow all the manufacturer's specific instructions included with your bike.

REI—Your Authorized Co-op Cycles Retailer

REI is your primary contact for service and adjustment of your bicycle, instruction in its use, and any warranty questions.

Your new bike will be delivered by REI in a completely assembled and properly adjusted condition, complete with all required safety equipment, Owner's Manuals, any Co-op Cycles Owner's Manual Supplements, and the available manufacturer's instructions (shipped by Co-op Cycles) for parts and components for your bike.

To find your nearest REI store, visit REI.com.

Use Only Genuine Replacement Parts

It is important to your safety and the performance of your Co-op Cycles bicycle that you use only genuine Co-op Cycles replacement parts.

This note does not apply to widely used generic bicycle components such as derailleurs.

CONTENTS

PART I

GENERAL WARNING.....	4
A SPECIAL NOTE FOR PARENTS	4
SECTION 1. FIRST	5-8
1.A Bike Fit.....	5
1.B Safety First	5
1.C Mechanical Safety Check.....	6
1.D First Ride	8
SECTION 2. SAFETY	8-14
2.A The Basics	9
2.B Riding Safety.....	10
2.C Off-Road Safety.....	11
2.D Wet-Weather Riding	11
2.E Night Riding.....	12
2.F Extreme, Stunt, or Competition Riding	13
2.G Changing Components/Adding Accessories	14
SECTION 3. FIT	15-19
3.A Standover Height	15
3.B Saddle Position.....	16
3.C. Handlebar Height and Angle.....	18
3.D Control Position Adjustments	19
3.E Brake Reach.....	19
SECTION 4. TECH	20 - 37
4.A Wheels	20
4.B Seatpost Cam Action Clamp.....	26
4.C Brakes.....	27
Coaster Brakes	30
4.D Shifting Gears.....	31
4.E Pedals.....	33
4.F Bicycle Suspension	34
4.G Tires and Tubes	35
SECTION 5. SERVICE	38-41
5.A Service Intervals.....	39
5.B If Your Bicycle Sustains an Impact.....	41

PART II

SECTION A. IMPORTANT SAFETY INFO...42-51	
A Wide Range of Injuries Are Possible	42
Bicycles Cannot Protect You	42
Bicycling Inherent Risk	42
Warning Label	43
Riding in Traffic, Commuting	43
Riding at Night, Dusk, Dawn	44
Refinishing	45
Modifications	45
Child Carriers.....	46
Bicycles Have Sharp Surfaces	46
Bar Ends	46
Installing Accessories	46
Aerodynamic Handlebars	47
About Shimmy	48
Toe Clip Overlap	48
Shifting Gears While Pedaling.....	48
Tire Size.....	49
Tire & Rim Pressure Compatibility	49
How to Check Wheel Rim Wear.....	50
Understanding Disc Brakes on Road Bikes	50
Brake Power Modulators	51
Aftermarket Brake Systems	51
Aftermarket Power Systems	51
SECTION B. INTENDED USE	52-57
This section also includes weight limit information.	
CONDITION 0 Children's Sidewalk	53
CONDITION 1 High-Performance Road	53
CONDITION 2 General Purpose Riding	54
CONDITION 3 Cross-Country, Marathon, Hardtails	55
CONDITION 4 All Mountain, Overmountain.....	56
CONDITION 5 Gravity, Freeride, Downhill, Dirt Jump.....	57

SECTION C. MOUNTAIN BIKE RIDING 58-61

Off-Road Riding	58
Bike Types.....	58
Inspection and Maintenance Routines.....	58
Suspension	59
Jumping	59
Stay In Control	59
Downhill and Lift-Serviced Riding	59
Freeride and Downhill Riding	60

SECTION D. INSPECT FOR SAFETY..... 62-68

1. Understanding Metals.....	63
2. Understanding Composites (Carbon Fiber)	66
3. Understanding Components.....	68

SECTION E. MAINTENANCE 69-74

Warranty Tune.....	69
Cleaning.....	69
Preventing Corrosion	69
Lubrication	70
Tightening Torques.....	70
Repair/Work Stands.....	71
Riding Through Water.....	71
Protect From Extreme Temperatures	71
Applying Frame Protection.....	72
Water Bottles	73
Serial Number.....	74

SECTION F. LIMITED WARRANTY75

Product Registration	75
REI Limited Warranty.....	75

SECTION G. PRE-RIDE CHECKLIST76

APPENDIX

A. Maximum Fork Length.....	77
B. Care And Maintenance Of Carbon Fiber Seatposts	78
C. Care And Maintenance Of Carbon Fiber Forks And Stems	80
D. Full Suspension Bicycles	83
E. Bicycle Racks	84
F. Using Bicycle Trainers.....	86
Trainers: Risks To Children	

PART I

GENERAL WARNING

Like any sport, bicycling involves risk of injury and damage. By choosing to ride a bicycle, you assume the responsibility for that risk, so you need to know—and to practice—the rules of safe and responsible riding and of proper use and maintenance. Proper use and maintenance of your bicycle reduces risk of injury.

This Manual contains many “Warnings” and “Cautions” concerning the consequences of failure to maintain or inspect your bicycle and of failure to follow safe cycling practices.

The combination of the safety alert symbol  and the word WARNING indicates a potentially hazardous situation which, if not avoided, could result in serious injury or death.

The combination of the safety alert symbol  and the word CAUTION indicates a potentially hazardous situation which, if not avoided, may result in minor or moderate injury, or is an alert against unsafe practices.

The word CAUTION used without the safety alert symbol indicates a situation which, if not avoided, could result in serious damage to the bicycle or the voiding of your warranty.

Many of the Warnings and Cautions say “you may lose control and fall.” Because any fall can result in serious injury or even death, we do not always repeat the warning of possible injury or death.

Because it is impossible to anticipate every situation or condition which can occur while riding, this Manual makes no representation about the safe use of the bicycle under all conditions. There are risks associated with the use of any bicycle which cannot be predicted or avoided, and which are the sole responsibility of the rider.

A SPECIAL NOTE FOR PARENTS

WARNING

This manual does not cover Juvenile or BMX bicycles.

As a parent or guardian, you are responsible for the activities and safety of your minor child, and that includes making sure that the bicycle is properly fitted to the child; that it is in good repair and safe operating condition; that you and your child have learned and understand the safe operation of the bicycle; and that you and your child have learned, understand and obey not only the applicable local motor vehicle, bicycle and traffic laws, but also the common sense rules of safe and responsible bicycling. As a parent, you should read this manual, as well as review its warnings and the bicycle’s functions and operating procedures with your child, before letting your child ride the bicycle.

WARNING

MAKE SURE THAT YOUR CHILD ALWAYS WEARS AN APPROVED BICYCLE HELMET WHEN RIDING; BUT ALSO MAKE SURE THAT YOUR CHILD UNDERSTANDS THAT A BICYCLE HELMET IS FOR BICYCLING ONLY AND MUST BE REMOVED WHEN NOT RIDING.

A helmet must not be worn while playing, in play areas, on playground equipment, while climbing trees, or at any time while not riding a bicycle. Failure to follow this warning could result in serious injury or death.

SECTION 1. FIRST

NOTE:

We strongly urge you to read this Manual in its entirety before your first ride. At the very least, read and make sure that you understand each point in this section, and refer to the cited sections on any issue which you don’t completely understand. Please note that not all bicycles have all of the features described in this manual. Ask REI to point out the features of your bicycle.

1.A - BIKE FIT

1. Is your bike the right size? To check, see SECTION 3.A. If your bicycle is too large or too small for you, you may lose control and fall. If your new bike is not the right size, ask REI to exchange it before you ride it.
2. Is the saddle at the right height? To check, see SECTION 3.B. If you adjust your saddle height, follow the Minimum Insertion instructions in SECTION 3.B.
3. Are saddle and seatpost securely clamped? A correctly tightened saddle will allow no saddle movement in any direction. See SECTION 3.B.
4. Are the stem and handlebar at the right height for you? If not, see SECTION 3.C.
5. Can you comfortably operate the brakes? If not, you may be able to adjust their angle and reach. See SECTION 3.D and 3.E.
6. Do you fully understand how to operate your new bicycle? If not, before your first ride, have REI explain any functions or features that you do not understand.

1.B - SAFETY FIRST

1. Always wear an approved helmet when riding your bike, and follow the helmet manufacturer’s instructions for fit, use and care.
2. Do you have all the other required and recommended safety equipment? See SECTION 2. It’s your responsibility to familiarize yourself with the laws of the areas where you ride, and to comply with all applicable laws.
3. Do you know how to correctly operate your wheel quick releases? Check SECTION 4.A.1 to make sure. Riding with an improperly adjusted wheel quick release can cause the wheel to wobble or disengage from the bicycle, and cause serious injury or death.
4. If your bike has toeclips and straps or clipless (“step-in”) pedals, make sure you know how they work (see SECTION 4.E). These pedals require special techniques and skills. Follow the pedal manufacturer’s instructions for use, adjustment and care.
5. Do you have “toe overlap”? On smaller framed bicycles your toe or toeclip may be able to contact the front wheel when a pedal is all the way forward and the wheel is turned. Read SECTION 4.E. If you have toeclip overlap.
6. Does your bike have suspension? If so, check SECTION 4.F. Suspension can change the way a bicycle performs. Follow the suspension manufacturer’s instructions for use, adjustment and care.

PART I

1.C - MECHANICAL SAFETY CHECK

Routinely check the condition of your bicycle before every ride.

Nuts, Bolts, Screws & Other Fasteners

Because manufacturers use a wide variety of fastener sizes and shapes made in a variety of materials, often differing by model and component, the correct tightening force or torque cannot be generalized.

To make sure that the many fasteners on your bicycle are correctly tightened, see page 78.

Always refer to the torque specifications in the instructions provided by the manufacturer of a component in question.

Correctly tightening a fastener requires a calibrated torque wrench. A professional bicycle mechanic with a torque wrench should torque the fasteners on your bicycle. If you choose to work on your own bicycle, you must use a torque wrench and the correct tightening torque specifications from the bicycle or component manufacturer or from REI. If you need to make an adjustment at home or in the field, we urge you to exercise care, and to have the fasteners you worked on checked by REI as soon as possible.

Note that there are some components which require special tools and knowledge. In Sections 3 and 4, we discuss the items which you may be able to adjust yourself. All other adjustments and repairs should be done by a qualified bike mechanic.

WARNING

CORRECT TIGHTENING FORCE ON FASTENERS –NUTS, BOLTS, SCREWS– ON YOUR BICYCLE IS IMPORTANT.

Too little force, and the fastener may not hold securely. Too much force, and the fastener can strip threads, stretch, deform or break. Either way, incorrect tightening force can result in component failure, which can cause you to lose control and fall.

Make sure nothing is loose. Lift the front wheel off the ground by two or three inches, then let it bounce on the ground. Anything sound, feel or look loose? Do a visual and tactile inspection of the whole bike. Any loose parts or accessories? If so, secure them. If you're not sure, ask someone with experience to check.

Tires & Wheels

Make sure tires are correctly inflated (see SECTION 4.G.1). Check by putting one hand on the saddle and one on the intersection of the handlebar and stem, then bouncing your weight on the bike while looking at tire deflection. Compare what you see with how it looks when you know the tires are correctly inflated, and adjust if necessary.

Tires in good shape? Spin each wheel slowly and look for cuts in the tread and sidewall. Replace damaged tires before riding the bike.

Wheels true? Spin each wheel and check for brake clearance and side-to-side wobble. If a wheel wobbles side-to-side even slightly, or rubs against or hits the brake pads, take the bike to a qualified bike shop to have the wheel trued.

CAUTION

Wheels must be true for the brakes to work effectively. Wheel truing is a skill which requires special tools and experience. Do not attempt to true a wheel unless you have the knowledge, experience and tools needed to do the job correctly.

Wheel rims clean and undamaged? Make sure the rims are clean and undamaged at the tire bead and, if you have rim brakes, along the braking surface. Check to make sure that any rim wear indicator marking is not visible at any point on the wheel rim.

WARNING

BICYCLE WHEEL RIMS ARE SUBJECT TO WEAR.

Ask REI about wheel rim wear. Some wheel rims have a rim wear indicator which becomes visible as the rim's braking surface wears. A visible rim wear indicator on the side of the wheel rim is an indication that the wheel rim has reached its maximum usable life. Riding a wheel that is at the end of its usable life can result in wheel failure, which can cause you to lose control and fall.

Brakes

Check the brakes for proper operation (see SECTION 4.C). Squeeze the brake levers. Are the brake quick-releases closed? All control cables seated and securely engaged? Do the brake pads contact the wheel rim squarely and make full contact with the rim? Do the brake pads touch the wheel rim within an inch of brake lever movement? Can you apply full braking force at the levers without having them touch the handlebar? If not, your brakes need adjustment. Do not ride the bike until the brakes are properly adjusted by a professional bicycle mechanic.

Wheel Retention System

Make sure the front and rear wheels are correctly secured. See SECTION 4.A.

Seatpost

If your seatpost has an over-center cam action fastener for easy height adjustment, check that it is properly adjusted and in the locked position. See Section 4.B.

Handlebar and Saddle Alignment

Make sure the saddle and handlebar stem are parallel to the bike's center line and clamped tight enough so that you can't twist them out of alignment. See SECTION 3.B and 3.C.

Handlebar Ends

Make sure the handlebar grips are secure and in good condition. If not, have REI replace them. Make sure the handlebar ends and extensions are plugged. If not, plug them before you ride. If the handlebars have bar-end extensions, make sure they are clamped tight enough so you can't twist them.

WARNING

LOOSE OR DAMAGED HANDLEBAR GRIPS OR EXTENSIONS CAN CAUSE YOU TO LOSE CONTROL AND FALL. UNPLUGGED HANDLEBARS OR EXTENSIONS CAN CUT YOU AND CAUSE SERIOUS INJURY IN AN OTHERWISE MINOR ACCIDENT.

VERY IMPORTANT SAFETY NOTE:

Please also read and become thoroughly familiar with the important information on the lifespan of your bicycle and its components in PART II, SECTION D. INSPECT FOR SAFETY.

PART I

1.D - FIRST RIDE

When you buckle on your helmet and go for your first familiarization ride on your new bicycle, be sure to pick a controlled environment, away from cars, other cyclists, obstacles or other hazards. Ride to become familiar with the controls, features and performance of your new bike.

Familiarize yourself with the braking action of the bike (see SECTION 4.C). Test the brakes at slow speed, putting your weight toward the rear and gently applying the brakes, rear brake first. Sudden or excessive application of the front brake could pitch you over the handlebar. Applying brakes too hard can lock up a wheel, which could cause you to lose control and fall. Skidding is an example of what can happen when a wheel locks up.

If your bicycle has toeclips or clipless pedals, practice getting in and out of the pedals. See paragraph B.4 above and SECTION 4.E.4.

If your bike has suspension, familiarize yourself with how the suspension responds to brake application and rider weight shifts. See paragraph B.6 above and SECTION 4.F.

Practice shifting the gears (see SECTION 4.D). Remember to never move the shifter while pedaling backward, nor pedal backward immediately after having moved the shifter. This could jam the chain and cause serious damage to the bicycle.

Check out the handling and response of the bike; and check the comfort.

If you have any questions, or if you feel anything about the bike is not as it should be, consult REI before you ride.

SECTION 2. SAFETY



WARNING

MANY STATES REQUIRE SPECIFIC SAFETY DEVICES. IT IS YOUR RESPONSIBILITY TO FAMILIARIZE YOURSELF WITH THE LAWS OF THE STATE WHERE YOU RIDE AND TO COMPLY WITH ALL APPLICABLE LAWS, INCLUDING PROPERLY EQUIPPING YOURSELF AND YOUR BIKE AS THE LAW REQUIRES.

Observe all local bicycle laws and regulations.

Observe regulations about bicycle lighting, licensing of bicycles, riding on sidewalks, laws regulating bike path and trail use, helmet laws, child carrier laws, special bicycle traffic laws.

It's your responsibility to know and obey the laws.

2.A - THE BASICS

1. Always wear a cycling helmet which meets the latest certification standards and is appropriate for the type of riding you do. Always follow the helmet manufacturer's instructions for fit, use and care of your helmet. Most serious bicycle injuries involve head injuries which might have been avoided if the rider had worn an appropriate helmet.



Figure 1. Bicycle Helmet

Your helmet should be:

- U.S. Consumer Product Safety Commission (CPSC) certified (look for the label on the helmet)
- Properly sized for you
- Properly fitted to you
- Properly attached to your head!
- Undamaged

ASK REI FOR HELP



WARNING

FAILURE TO WEAR A HELMET WHEN RIDING MAY RESULT IN SERIOUS INJURY OR DEATH.

2. Always do the Mechanical Safety Check (SECTION 1.C) before you get on a bike.
3. Be thoroughly familiar with the controls of your bicycle: brakes (SECTION 4.C.); pedals (SECTION 4.E.); shifting (SECTION 4.D.)
4. Be careful to keep body parts and other objects away from the sharp teeth of chainrings, the moving chain, the turning pedals and cranks, and the spinning wheels of your bicycle.
5. Always wear:
 - Shoes that will stay on your feet and will grip the pedals. Never ride barefoot or in sandals.
 - Bright, visible clothing that is not so loose that it can be tangled in the bicycle or snagged by objects at the side of the road or trail.
 - Protective eye wear, to protect against airborne dirt, dust and bugs –tinted when the sun is bright, clear when it's not.
6. Unless your bicycle was specifically designed for jumping, don't jump with your bike. Jumping a bike, particularly a BMX or mountain bike, can be fun; but it can put huge and unpredictable stress on the bicycle and its components. Riders who insist on jumping their bikes risk serious damage, to their bicycles as well as to themselves. Before you attempt to jump, do stunt riding or race with your bike, read and understand SECTION 2.F.
7. Ride at a speed appropriate for conditions. Increased speed means higher risk.

PART I

2.B - RIDING SAFETY

1. Obey all rules of the road and all local traffic laws.
2. You are sharing the road or the path with others—motorists, pedestrians and other cyclists. Respect their rights.
3. Ride defensively. Always assume that others do not see you.
4. Look ahead, and be ready to avoid:
 - Vehicles slowing or turning, entering the road or your lane ahead of you, or coming up behind you.
 - Parked car doors opening.
 - Pedestrians stepping out.
 - Children or pets playing near the road.
 - Potholes, sewer grating, railroad tracks, expansion joints, road or sidewalk construction, debris and other obstructions that could cause you to swerve into traffic, catch your wheel or otherwise cause you to lose control and have an accident.
 - The many other hazards and distractions which can occur on a bicycle ride.
5. Ride in designated bike lanes, on designated bike paths or as close to the edge of the road as possible, in the direction of traffic flow or as directed by local governing laws.
6. Stop at stop signs and traffic lights; slow down and look both ways at street intersections. Remember that a bicycle always loses in a collision with a motor vehicle, so be prepared to yield even if you have the right of way.
7. Use approved hand signals for turning and stopping.
8. Never ride with headphones. They mask traffic sounds and emergency vehicle sirens, distract you from concentrating on what's going on around you, and their wires can tangle in the moving parts of the bicycle, causing you to lose control.
9. Never carry a passenger, and before installing a child carrier or trailer, check with REI to make sure the bicycle is designed for it. If the bicycle is suitable for a child carrier or trailer, make sure that the carrier or trailer is correctly mounted and the child secured and wearing an approved and properly fitted helmet.
10. Never carry anything which obstructs your vision or your complete control of the bicycle, or which could become entangled in the moving parts of the bicycle.
11. Never hitch a ride by holding on to another vehicle.
12. Don't do stunts, wheelies or jumps. If you intend to do stunts, wheelies, jumps or go racing with your bike despite our advice not to, read SECTION 2.F, Downhill, Stunt or Competition Biking, **now**. Think carefully about your skills before deciding to take the large risks that go with this kind of riding.
13. Don't weave through traffic or make any moves that may surprise people with whom you are sharing the road.
14. Observe and yield the right of way.
15. Never ride your bicycle while under the influence of alcohol or drugs.
16. If possible, avoid riding in bad weather, when visibility is obscured, at dawn, dusk or in the dark, or when extremely tired. Each of these conditions increases the risk of accident.

2.C - OFF-ROAD SAFETY

We recommend that children not ride on rough terrain unless they are accompanied by an adult.

1. The variable conditions and hazards of off-road riding require close attention and specific skills. Start slowly on easier terrain and build up your skills. If your bike has suspension, the increased speed you may develop also increases your risk of losing control and falling. Get to know how to handle your bike safely before trying increased speed or more difficult terrain.
2. Wear safety gear appropriate to the kind of riding you plan to do.
3. Don't ride alone in remote areas. Even when riding with others, make sure that someone knows where you're going and when you expect to be back.
4. Always take along some kind of identification, so that people know who you are in case of an accident; and take along a couple of dollars in cash for a candy bar, a cool drink or an emergency phone call.
5. Yield right of way to pedestrians and animals. Ride in a way that does not frighten or endanger them, and give them enough room so that their unexpected moves don't endanger you.
6. Be prepared. If something goes wrong while you're riding off-road, help may not be close.
7. Before you attempt to jump, do stunt riding or race with your bike, read and understand SECTION 2.F.

Off-Road Respect

Obey the local laws regulating where and how you can ride off-road, and respect private property. You may be sharing the trail with others—hikers, equestrians, other cyclists. Respect their rights. Stay on the designated trail. Don't contribute to erosion by riding in mud or with unnecessary sliding. Don't disturb the ecosystem by cutting your own trail or shortcut through vegetation or streams. It is your responsibility to minimize your impact on the environment. Leave things as you found them; and always take out everything you brought in.

2.D - WET-WEATHER RIDING

Under wet conditions, the stopping power of your brakes (as well as the brakes of other vehicles sharing the road) is dramatically reduced and your tires don't grip nearly as well. This makes it harder to control speed and easier to lose control.



WARNING

WET WEATHER IMPAIRS TRACTION, BRAKING AND VISIBILITY, BOTH FOR THE BICYCLIST AND FOR OTHER VEHICLES SHARING THE ROAD.

The risk of an accident is dramatically increased in wet conditions.

To make sure that you can slow down and stop safely in wet conditions, ride more slowly and apply your brakes earlier and more gradually than you would under normal, dry conditions. See also SECTION 4.C.

PART I

2.E - NIGHT RIDING

Riding a bicycle at night is much more dangerous than riding during the day. A bicyclist is very difficult for motorists and pedestrians to see. Therefore, children should never ride at dawn, at dusk or at night. Adults who chose to accept the greatly increased risk of riding at dawn, at dusk or at night need to take extra care both riding and choosing specialized equipment which helps reduce that risk. Consult REI about night riding safety equipment.

WARNING

REFLECTORS ARE NOT A SUBSTITUTE FOR REQUIRED LIGHTS. RIDING AT DAWN, AT DUSK, AT NIGHT OR AT OTHER TIMES OF POOR VISIBILITY WITHOUT AN ADEQUATE BICYCLE LIGHTING SYSTEM AND WITHOUT REFLECTORS IS DANGEROUS AND MAY RESULT IN SERIOUS INJURY OR DEATH.

Bicycle reflectors are designed to pick up and reflect street lights and car lights in a way that may help you to be seen and recognized as a moving bicyclist.

CAUTION

Check reflectors and their mounting brackets regularly to make sure that they are clean, straight, unbroken and securely mounted. Have REI replace damaged reflectors and straighten or tighten any that are bent or loose.

The mounting brackets of front and rear reflectors are often designed as brake straddle cable safety catches which prevent the straddle cable from catching on the tire tread if the cable jumps out of its yoke or breaks.

WARNING

DO NOT REMOVE THE FRONT OR REAR REFLECTORS OR REFLECTOR BRACKETS FROM YOUR BICYCLE.

They are an integral part of the bicycle's safety system.

REMOVING THE REFLECTORS MAY REDUCE YOUR VISIBILITY TO OTHERS USING THE ROADWAY. BEING STRUCK BY OTHER VEHICLES MAY RESULT IN SERIOUS INJURY OR DEATH.

The reflector brackets may protect you from the brake straddle cable catching on the tire in the event of brake cable failure. If a brake straddle cable catches on the tire, it can cause the wheel to stop suddenly, causing you to lose control and fall.

If you choose to ride under conditions of poor visibility, check and be sure you comply with all local laws about night riding, and take the following strongly recommended additional precautions:

- Purchase and install battery- or generator-powered head and tail lights which meet all regulatory requirements and provide adequate visibility.
- Wear light colored, reflective clothing and accessories, such as a reflective vest, reflective arm and leg bands, reflective stripes on your helmet, flashing lights attached to your body and/or your bicycle ... any reflective device or light source that moves will help you get the attention of approaching motorists, pedestrians and other traffic.
- Make sure your clothing or anything you may be carrying on the bicycle does not obstruct a reflector or light.
- Make sure that your bicycle is equipped with correctly positioned and securely mounted reflectors.

WHILE RIDING AT DAWN, AT DUSK OR AT NIGHT:

- Ride slowly.
- Avoid dark areas and areas of heavy or fast-moving traffic.
- Avoid road hazards.
- If possible, ride on familiar routes.

IF RIDING IN TRAFFIC:

- Be predictable. Ride so that drivers can see you and predict your movements.
- Be alert. Ride defensively and expect the unexpected.
- If you plan to ride in traffic often, ask REI about traffic safety classes or a good book on bicycle traffic safety.

2.F - EXTREME, STUNT OR COMPETITION RIDING

Whether you call it Aggro, Hucking, Freeride, North Shore, Downhill, Jumping, Stunt Riding, Racing or something else: if you engage in this sort of extreme, aggressive riding you **will** get hurt, and you voluntarily assume a greatly increased risk of injury or death.

Not all bicycles are designed for these types of riding, and those that are may not be suitable for all types of aggressive riding. Check with REI about the suitability of your bicycle before engaging in extreme riding.

When riding fast downhill, you can reach speeds achieved by motorcycles, and therefore face similar hazards and risks. Have your bicycle and equipment carefully inspected by a qualified mechanic and be sure it is in perfect condition. Consult with expert riders and race officials on conditions and equipment advisable at the site where you plan to ride. Wear appropriate safety gear, including an approved full-face helmet, full-finger gloves, and body armor. Ultimately, it is your responsibility to have proper equipment and to be familiar with course conditions.

WARNING

ALTHOUGH MANY CATALOGS, ADVERTISEMENTS AND ARTICLES ABOUT BICYCLING DEPICT RIDERS ENGAGED IN EXTREME RIDING, THIS ACTIVITY IS EXTREMELY DANGEROUS, INCREASES YOUR RISK OF INJURY OR DEATH, AND INCREASES THE SEVERITY OF ANY INJURY.

Remember that the action depicted is being performed by professionals with many years of training and experience.

Know your limits and always wear a helmet and other appropriate safety gear. Even with state-of-the-art protective safety gear, you could be seriously injured or killed when jumping, stunt riding, riding downhill at speed or in competition.

WARNING

Bicycles and bicycle parts have limitations with regard to strength and integrity, and this type of riding can exceed those limitations or dramatically reduce the length of their safe use.

(continued on next page...)

PART I

(continued from previous page...)

We recommend against this type of riding because of the increased risks; but if you choose to take the risk, at least:

- Take lessons from a competent instructor first
- Start with easy learning exercises and slowly develop your skills before trying more difficult or dangerous riding.
- Use only designated areas for stunts, jumping, racing or fast downhill riding
- Wear a full-face helmet, safety pads and other safety gear.
- Understand and recognize that the stresses imposed on your bike by this kind of activity may break or damage parts of the bicycle and void the warranty.
- Take your bicycle to REI if anything breaks or bends. Do not ride your bicycle when any part is damaged.

If you ride downhill at speed, do stunt riding or ride in competition, know the limits of your skill and experience. Ultimately, avoiding injury is your responsibility.

2.G - CHANGING COMPONENTS OR ADDING ACCESSORIES

There are many components and accessories available to enhance the comfort, performance and appearance of your bicycle. However, if you change components or add accessories, you do so at your own risk. REI may not have tested that component or accessory for compatibility, reliability or safety on your bicycle.

Before installing any component or accessory, including a different size tire, make sure that it is compatible with your bicycle by checking with REI.

Be sure to read, understand and follow the instructions that accompany the products you purchase for your bicycle. See also PART II, SECTION D. INSPECT FOR SAFETY.

Be sure to read, understand and follow the instructions that accompany the products you purchase for your bicycle. See also PART II, SECTION D. INSPECT FOR SAFETY.

WARNING

FAILURE TO CONFIRM COMPATIBILITY, PROPERLY INSTALL, OPERATE AND MAINTAIN ANY COMPONENT OR ACCESSORY CAN RESULT IN SERIOUS INJURY OR DEATH.

WARNING

Changing the components on your bike with anything other than genuine replacement parts compromises the safety of your bicycle and may void the warranty. Check with REI before changing the components on your bike.

SECTION 3. FIT

NOTE: Correct fit is an essential element of bicycling safety, performance and comfort. Making the adjustments to your bicycle which result in correct fit for your body and riding conditions requires experience, skill and special tools. Always have REI make the adjustments on your bicycle; or, if you have the experience, skill and tools, have REI check your work before riding.

WARNING

IF YOUR BICYCLE DOES NOT FIT PROPERLY, YOU MAY LOSE CONTROL AND FALL.

If your new bike doesn't fit, ask REI to exchange it before you ride it.

3.A - STANDOVER HEIGHT

1. Diamond frame bicycles

Standover height is the basic element of bike fit (see fig. 2). It is the distance from the ground to the top of the bicycle's frame at that point where your crotch is when straddling the bike. To check for correct standover height, straddle the bike while wearing the kind of shoes in which you'll be riding, and bounce vigorously on your heels. If your crotch touches the frame, the bike is too big for you. Don't even ride the bike around the block. A bike which you ride only on paved surfaces and never take off-road should give you a minimum standover height clearance of two inches (5 cm). A bike that you'll ride on unpaved surfaces should give you a minimum of three inches (7.5 cm) of standover height clearance. And a bike that you'll use off road should give you four inches (10 cm) or more of clearance.

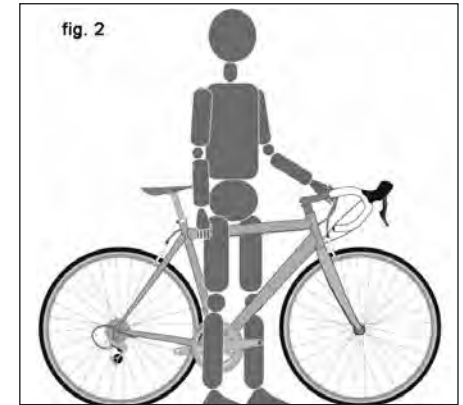

Figure 2. Standover Height

WARNING

IF YOU PLAN TO USE YOUR BIKE FOR JUMPING OR STUNT RIDING, READ SECTION 2.F AGAIN.

2. Step-through frame bicycles

Standover height does not apply to bicycles with step-through frames. Instead, the limiting dimension is determined by saddle height range. You must be able to adjust your saddle position as described in 3.B. SADDLE POSITION without exceeding the limits set by the height of the top of the seat tube and the "Minimum Insertion" or "Maximum Extension" mark on the seatpost.

PART I

3.B - SADDLE POSITION

Correct saddle adjustment is an important factor in getting the most performance and comfort from your bicycle. If the saddle position is not comfortable for you, see REI.

The saddle can be adjusted in three directions:

1. Up and Down Adjustment

To check for correct saddle height (fig. 3):

- Sit on the saddle;
- Place one heel on a pedal;
- Rotate the crank until the pedal with your heel on it is in the down position and the crank arm is parallel to the seat tube.

If your leg is not completely straight, your saddle height needs to be adjusted. If your hips must rock for the heel to reach the pedal, the saddle is too high. If your leg is bent at the knee with your heel on the pedal, the saddle is too low.

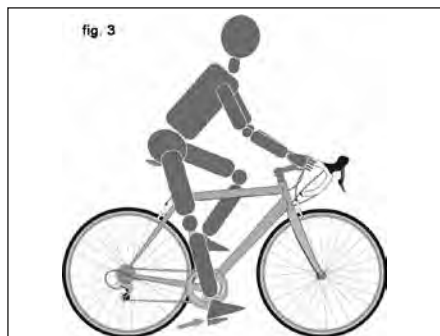

Figure 3. Saddle Position

Ask REI to set the saddle for your optimal riding position and to show you how to make this adjustment. If you choose to make your own saddle height adjustment:

- loosen the seatpost clamp
- raise or lower the seatpost in the seat tube
- make sure the saddle is straight fore and aft
- re-tighten the seatpost clamp to the recommended torque (See manufacturer's instructions).

Once the saddle is at the correct height, make sure that the seatpost does not project from the frame beyond its "Minimum Insertion" or "Maximum Extension" mark (fig. 4).

NOTE: Some bicycles have a sight hole in the seat tube, the purpose of which is to make it easy to see whether the seatpost is inserted in the seat tube far enough to be safe. If your bicycle has such a sight hole, use it instead of the "Minimum Insertion" or "Maximum Extension" mark to make sure the seatpost is inserted in the seat tube far enough to be visible through the sight hole.

If your bike has an interrupted seat tube, as is the case on some suspension bikes, you must also make sure that the seatpost is far enough into the frame so that you can touch it through the bottom of the interrupted seat tube with the tip of your finger without inserting your finger beyond its first knuckle. Also see NOTE above and fig. 5).

WARNING

If your seatpost is not inserted in the seat tube as described in B.1 above, the seatpost may break, which could cause you to lose control and fall.

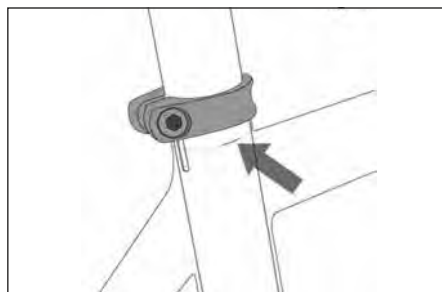

Figure 4. Minimum Insertion Mark



Figure 5. Interrupted Seat Tube

2. Front and Back Adjustment

The saddle can be adjusted forward or back to help you get the optimal position on the bike. Ask REI to set the saddle for your optimal riding position and to show you how to make this adjustment.

If you choose to make your own front and back adjustment, make sure that the clamp mechanism is clamping on the straight part of the saddle rails and is not touching the curved part of the rails, and that you are using the recommended torque on the clamping fastener(s) (See manufacturer's instructions).

3. Saddle Angle Adjustment

Most people prefer a horizontal saddle; but some riders like the saddle nose angled up or down just a little. REI can adjust saddle angle or teach you how to do it.

If you choose to make your own saddle angle adjustment and you have a single bolt saddle clamp on your seatpost, it is critical that you loosen the clamp bolt sufficiently to allow any serrations on the mechanism to disengage before changing the saddle's angle, and then that the serrations fully re-engage before you tighten the clamp bolt to the recommended torque (See manufacturer's instructions).

NOTE: If your bicycle is equipped with a suspension seatpost, periodically ask REI to check it. Ask REI for recommended service intervals for your suspension seatpost.

Small changes in saddle position can have a substantial effect on performance and comfort. To find your best saddle position, make only one adjustment at a time.

WARNING

When making saddle angle adjustments with a single bolt saddle clamp, always check to make sure that the serrations on the mating surfaces of the clamp are not worn. Worn serrations on the clamp can allow the saddle to move, causing you to lose control and fall.

Always tighten fasteners to the correct torque. Bolts that are too tight can stretch and deform. Bolts that are too loose can move and fatigue. Either mistake can lead to a sudden failure of the bolt, causing you to lose control and fall.

WARNING

After any saddle adjustment, be sure that the saddle adjusting mechanism is properly tightened before riding. A loose saddle clamp or seatpost binder can cause damage to the seatpost, or can cause you to lose control and fall.

A correctly tightened saddle adjusting mechanism will allow no saddle movement in any direction. Periodically check to make sure that the saddle adjusting mechanism is properly tightened.

(continued on next page...)

PART I

(continued from previous page...)

If, in spite of carefully adjusting the saddle height, tilt and fore-and-aft position, your saddle is still uncomfortable, you may need a different saddle design. Saddles, like people, come in many different shapes, sizes and resilience. REI can help you select a saddle which, when correctly adjusted for your body and riding style, will be comfortable.

WARNING

Some people have claimed that extended riding with a saddle which is incorrectly adjusted or which does not support your pelvic area correctly can cause short-term or long-term injury to nerves and blood vessels, or even impotence.

If your saddle causes you pain, numbness or other discomfort, listen to your body and stop riding until you see REI about saddle adjustment or a different saddle.

3.C - Handlebar Height And Angle

Your bike is equipped either with a “threadless” stem, which clamps on to the outside of the steerer tube, or with a “quill” stem, which clamps inside the steerer tube by way of an expanding binder bolt. If you aren’t absolutely sure which type of stem your bike has, ask REI.

If your bike has a “threadless” stem (fig. 6), REI may be able to change handlebar height by moving height adjustment spacers from below the stem to above the stem, or vice versa. Otherwise, you’ll have to get a stem of different length or rise. Consult REI. Do not attempt to do this yourself, as it requires special knowledge.

If your bike has a “quill” stem (fig. 7), you can ask REI to adjust the handlebar height a bit by adjusting stem height.

A quill stem has an etched or stamped mark on its shaft which designates the stem’s “Minimum Insertion” or “Maximum Extension.” This mark must not be visible above the headset.

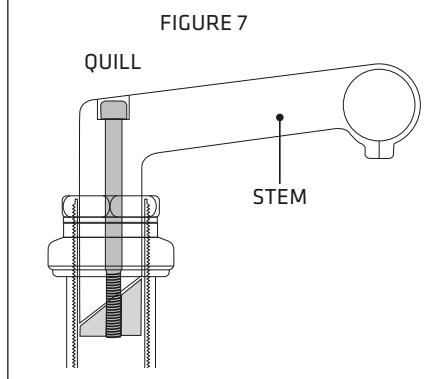
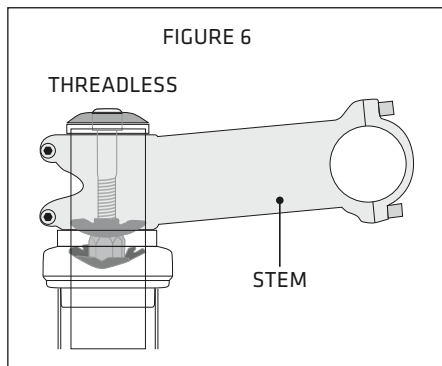

WARNING

A QUILL STEM’S “MINIMUM INSERTION MARK” MUST NOT BE VISIBLE ABOVE THE TOP OF THE HEADSET.

If the stem is extended beyond the minimum insertion mark the stem may break or damage the fork’s steerer tube, which could cause you to lose control and fall.

WARNING

There must always be a 5mm spacer on top of the stem that extends above the steerer tube by 2-3mm.

WARNING

On some bicycles, changing the stem or stem height can affect the tension of the front brake cable, locking the front brake or creating excess cable slack which can make the front brake inoperable. If the front brake pads move in towards the wheel rim or out away from the wheel rim when the stem or stem height is changed, the brakes must be correctly adjusted before you ride the bicycle.

Some bicycles are equipped with an adjustable-angle stem. If your bicycle has an adjustable-angle stem, ask REI to show you how to adjust it. Do not attempt to make the adjustment yourself, as changing stem angle may also require adjustments to the bicycle’s controls.

WARNING

Always tighten fasteners to the correct torque. Bolts that are too tight can stretch and deform. Bolts that are too loose can move and fatigue. Either mistake can lead to a sudden failure of the bolt, causing you to lose control and fall.

WARNING

AN INSUFFICIENTLY TIGHTENED STEM BINDER BOLT, HANDLEBAR BINDER BOLT OR BAR END EXTENSION CLAMPING BOLT MAY COMPROMISE STEERING ACTION, WHICH COULD CAUSE YOU TO LOSE CONTROL AND FALL.

Place the front wheel of the bicycle between your legs and attempt to twist the handlebar/stem assembly. If you can twist the stem in relation to the front wheel, turn the handlebar in relation to the stem, or turn the bar end extensions in relation to the handlebar, the bolts are insufficiently tightened.

REI can also change the angle of the handlebar or bar end extensions.

3.D - Control Position Adjustments

The angle of the brake and shift control levers and their position on the handlebar can be changed. Ask REI to make the adjustments for you.

If you choose to make your own control lever angle adjustment, be sure to re-tighten the clamp fasteners to the recommended torque (See manufacturer’s instructions).

3.E - Brake Reach

Many bikes have brake levers which can be adjusted for reach. If you have small hands or find it difficult to squeeze the brake levers, REI may be able to adjust the reach or fit shorter reach brake levers.

WARNING

THE SHORTER THE BRAKE LEVER REACH, THE MORE CRITICAL IT IS TO HAVE CORRECTLY ADJUSTED BRAKES, SO THAT FULL BRAKING POWER CAN BE APPLIED WITHIN AVAILABLE BRAKE LEVER TRAVEL.

Brake lever travel insufficient to apply full braking power can result in loss of control, which may result in serious injury or death.

PART I

SECTION 4. TECH

It's important to your safety, performance and enjoyment to understand how things work on your bicycle.

We urge you to ask REI how to do the things described in this section before you attempt them yourself, and that you have REI check your work before you ride the bike.

If you have even the slightest doubt as to whether you understand something in this section of the Manual, talk to REI.

See also:

PART I "Coaster Brakes"
PART II, SECTION B., INTENDED USE
PART II, SECTION D., INSPECT FOR SAFETY
PART II, SECTION E., MAINTENANCE

4.A - Wheels

Bicycle wheels are designed to be removable for easier transportation and for repair of a tire puncture. In most cases, the wheel axles are inserted into slots, called "dropouts" in the fork and frame, but some new bikes use what is called a "through-axle" wheel mounting system.

If you have a bike equipped with through-axle front or rear wheels, make sure that REI has given you the manufacturer's instructions, and follow those when installing or removing a through-axle wheel. If you don't know what a through-axle is, ask REI.

If you do not have a bicycle with a through-axle mounting system, it will have wheel secured in one of the following three ways:

- A hollow axle with a shaft ("skewer") running through it which has an adjustable tension nut on one end and an over-center cam on the other (cam action system, fig. 8a & 8b).
- A hollow axle with a shaft ("skewer") running through it which has a nut on one end and a fitting for a hex key, lock lever or other tightening device on the other (through bolt, fig. 9)
- Hex nuts or hex key bolts which are threaded onto or into the hub axle (bolt-on wheel, fig. 10)

WARNING

RIDING WITH AN IMPROPERLY SECURED WHEEL CAN ALLOW THE WHEEL TO WOBBLE OR FALL OFF THE BICYCLE, OR TO SUDDENLY STOP, WHICH CAN CAUSE SERIOUS INJURY OR DEATH. THEREFORE, IT IS ESSENTIAL THAT YOU:

1. Ask REI to help you make sure you know how to install and remove your wheels safely.
2. Understand and apply the correct technique for clamping your wheel in place.
3. Each time, before you ride the bike, check that the wheel is securely clamped. The clamping action of a correctly secured wheel must emboss the surfaces of the dropouts.

Some bicycles are equipped with a quick-release lever and a disc brake. If the bicycle is ridden with the lever incorrectly adjusted or open, and the lever contacts the disc or wheel (next figure), the front wheel could stop suddenly, causing the rider to fall. Always make sure your wheels are correctly attached, and the attachment mechanisms closed and locked, before riding the bicycle.

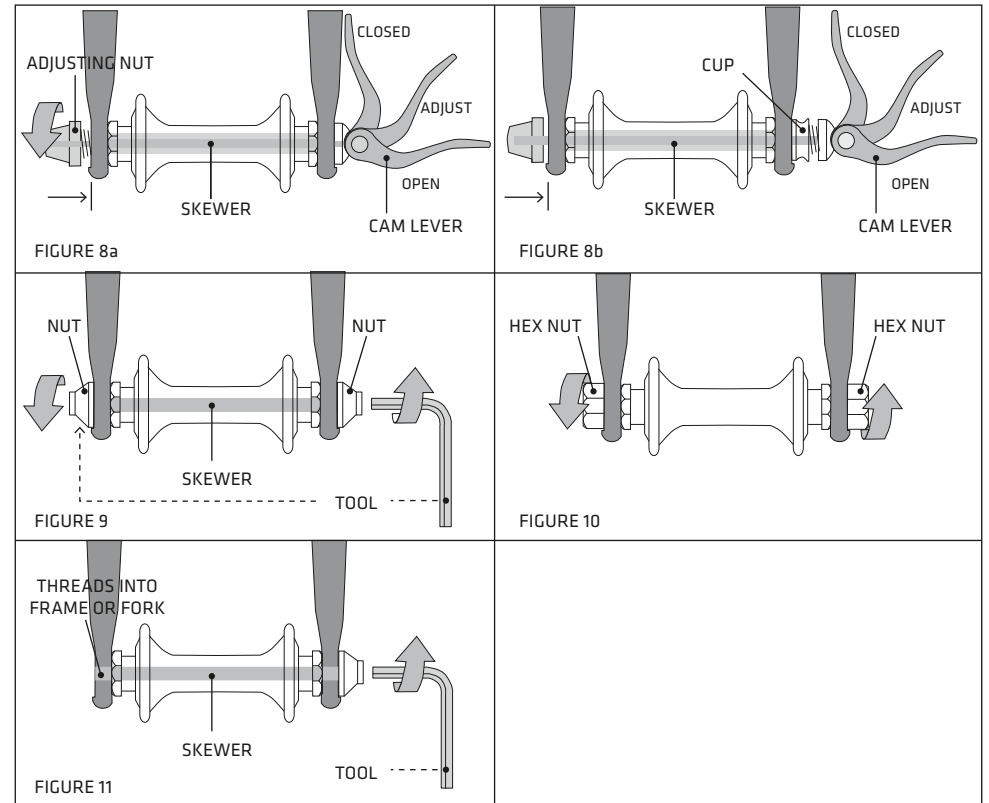
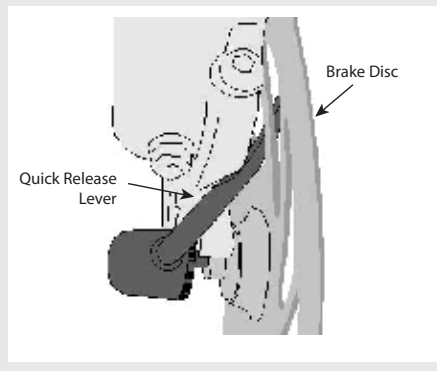

Your bicycle may be equipped with a different securing method for the front wheel than for the rear wheel. Discuss the wheel securing method for your bicycle with REI.

It is very important that you understand the type of wheel-securing method on your bicycle, that you know how to secure the wheels correctly, and that you know how to apply the correct clamping force that safely secures the wheel.

Ask REI to instruct you in correct wheel removal and installation, and ask for the manufacturer's instructions.

PART I

1. Front Wheel Secondary Retention Devices

Most bicycles have front forks which utilize a secondary wheel retention device to reduce the risk of the wheel disengaging from the fork if the wheel is incorrectly secured. Secondary retention devices are not a substitute for correctly securing your front wheel.

Secondary retention devices fall into two basic categories:

- a. The clip-on type is a part which the manufacturer adds to the front wheel hub or front fork.
- b. The integral type is molded, cast or machined into the outer faces of the front fork dropouts.

Ask REI to explain the particular secondary retention device on your bike.

WARNING

DO NOT REMOVE OR DISABLE THE SECONDARY RETENTION DEVICE.

As its name implies, it serves as a back-up for a critical adjustment. If the wheel is not secured correctly, the secondary retention device can reduce the risk of the wheel disengaging from the fork. Removing or disabling the secondary retention device may also void the warranty.

Secondary retention devices are not a substitute for correctly securing your wheel. Failure to properly secure the wheel can cause the wheel to wobble or disengage, which could cause you to lose control and fall, resulting in serious injury or death.

2. Wheels With Cam Action Systems

There are currently two types of over-center cam wheel retention mechanisms: the traditional over-center cam (fig. 8a) and the cam-and-cup system (fig. 8b). Both use an over-center cam action to clamp the bike's wheel in place. Your bicycle may have a cam-and-cup front wheel retention system and a traditional rear wheel cam action system.

a. Adjusting the traditional cam action mechanism (fig. 8a)

The wheel hub is clamped in place by the force of the over-center cam pushing against one dropout and pulling the tension-adjusting nut, by way of the skewer, against the other dropout. The amount of clamping force is controlled by the tension-adjusting nut. Turning the tension-adjusting nut clockwise while keeping the cam lever from rotating increases clamping force; turning it counterclockwise while keeping the cam lever from rotating reduces clamping force. Less than half a turn of the tension-adjusting nut can make the difference between safe clamping force and unsafe clamping force.

WARNING

THE FULL FORCE OF THE CAM ACTION IS NEEDED TO CLAMP THE WHEEL SECURELY.

Holding the nut with one hand and turning the lever like a wing nut with the other hand until everything is as tight as you can get it will not clamp a cam action wheel safely in the dropouts.

See also WARNING on page 20.

b. Adjusting the cam-and-cup mechanism (fig. 8B)

The cam-and-cup system on your front wheel will have been correctly adjusted for your bicycle by REI. Ask REI to check the adjustment every six months. Do not use a cam-and-cup front wheel on any bicycle other than the one for which REI adjusted it.

3. Removing and Installing Wheels

WARNING

IF YOUR BIKE IS EQUIPPED WITH A HUB BRAKE SUCH AS A REAR COASTER BRAKE, FRONT OR REAR DRUM, BAND OR ROLLER BRAKE; OR IF IT HAS AN INTERNAL GEAR REAR HUB, DO NOT ATTEMPT TO REMOVE THE WHEEL.

The removal and re-installation of most hub brakes and internal gear hubs requires special knowledge. Incorrect removal or assembly can result in brake or gear failure, which can cause you to lose control and fall.

CAUTION

If your bike has a disc brake, exercise care in touching the rotor or caliper. Disc rotors have sharp edges, and both rotor and caliper can get very hot during use.

a. Removing a disk brake or rim brake front wheel

- (1) If your bike has rim brakes, disengage the brake's quick-release mechanism to increase the clearance between the tire and the brake pads (See Section 4.C fig. 11 through 15).

- (2) If your bike has cam action front wheel retention, move the cam lever from the locked or CLOSED position to the OPEN position (figs. 8a & b). If your bike has through-bolt or bolt-on front wheel retention, loosen the fastener(s) a few turns counterclockwise using an appropriate wrench, lock key or the integral lever.

- (3) If your front fork has a clip-on type secondary retention device, disengage it. If your front fork has an integral secondary retention device, and a traditional cam action system (fig. 8a) loosen the tension-adjusting nut enough to allow removing the wheel from the dropouts. If your front wheel uses a cam-and-cup system, (fig. 8b) squeeze the cup and cam lever together while removing the wheel. No rotation of any part is necessary with the cam-and-cup system.

You may need to tap the top of the wheel with the palm of your hand to release the wheel from the front fork.

b. Installing a disk brake or rim brake front wheel

CAUTION

If your bike is equipped with a front disk brake, be careful not to damage the disk, caliper or brake pads when re-inserting the disk into the caliper. Never activate a disk brake's control lever unless the disk is correctly inserted in the caliper. See also Section 4.C.

- (1) If your bike has cam action front wheel retention, move the cam lever so that it curves away from the wheel (fig. 8b). This is the OPEN position. If your bike has through-bolt or bolt-on front wheel retention, go to the next step.

(continued on next page...)

(continued from previous page...)

- (2) With the steering fork facing forward, insert the wheel between the fork blades so that the axle seats firmly at the top of the fork dropouts. The cam lever, if there is one, should be on rider's left side of the bicycle (fig. 8a & b). If your bike has a clip-on type secondary retention device, engage it.
- (3) If you have a traditional cam action mechanism: holding the cam lever in the ADJUST position with your right hand, tighten the tension-adjusting nut with your left hand until it is finger tight against the fork dropout (fig. 8a). If you have a cam-and-cup system: the nut and cup (fig. 8b) will have snapped into the recessed area of the fork dropouts and no adjustment should be required.
- (4) While pushing the wheel firmly to the top of the slots in the fork dropouts, and at the same time centering the wheel rim in the fork:
 - (a) With a cam action system, move the cam lever upwards and swing it into the CLOSED position (fig. 8a & b). The lever should now be parallel to the fork blade and curved toward the wheel. To apply enough clamping force, you should have to wrap your fingers around the fork blade for leverage, and the lever should leave a clear imprint in the palm of your hand.
 - (b) With a through-bolt or bolt-on system, tighten the fasteners to the torque specifications in Appendix D or the hub manufacturer's instructions.

NOTE:

If, on a traditional cam action system, the lever cannot be pushed all the way to a position parallel to the fork blade, return the lever to the OPEN position. Then turn the tension-adjusting nut counterclockwise one-quarter turn and try tightening the lever again.

- (6) With a through-bolt or bolt-on system, tighten the fasteners to the torque specifications in "PART II Tightening Torques" or the hub manufacturer's instructions.

 **WARNING**

SECURELY CLAMPING THE WHEEL WITH A CAM ACTION RETENTION DEVICE TAKES CONSIDERABLE FORCE.

If you can fully close the cam lever without wrapping your fingers around the fork blade for leverage, the lever does not leave a clear imprint in the palm of your hand, and the serrations on the wheel fastener do not emboss the surfaces of the dropouts, the tension is insufficient. Open the lever; turn the tension-adjusting nut clockwise a quarter turn; then try again.

See also WARNING on page 20.

- (6) If you disengaged the brake quick-release mechanism in 3. a. (1) above, re-engage it to restore correct brake pad-to-rim clearance.
- (7) Spin the wheel to make sure that it is centered in the frame and clears the brake pads; then squeeze the brake lever and make sure that the brakes are operating correctly.

c. Removing a disk brake or rim brake rear wheel

- (1) If you have a multi-speed bike with a derailleur gear system: shift the rear derailleur to high gear (the smallest, outermost rear sprocket).

If you have an internal gear rear hub, consult REI or the hub manufacturer's instructions before attempting to remove the rear wheel.

If you have a single-speed bike with rim or disk brake, go to step (4) below.

- (2) If your bike has rim brakes, disengage the brake's quick-release mechanism to increase the clearance between the wheel rim and the brake pads (see Section 4.C, figs. 11 through 15).

- (3) On a derailleur gear system, pull the derailleur body back with your right hand.
- (4) With a cam action mechanism, move the quick-release lever to the OPEN position (fig. 8b). With a through bolt or bolt on mechanism, loosen the fastener(s) with an appropriate wrench, lock lever or integral lever; then push the wheel forward far enough to be able to remove the chain from the rear sprocket.
- (5) Lift the rear wheel off the ground a few inches and remove it from the rear dropouts.

d. Installing a disk brake or rim brake rear wheel

 **CAUTION**

If your bike is equipped with a rear disk brake, be careful not to damage the disk, caliper or brake pads when re-inserting the disk into the caliper. Never activate a disk brake's control lever unless the disk is correctly inserted in the caliper.

- (1) With a cam action system, move the cam lever to the OPEN position (see fig. 8a & b). The lever should be on the side of the wheel opposite the derailleur and freewheel sprockets.
- (2) On a derailleur bike, make sure that the rear derailleur is still in its outermost, high gear, position; then pull the derailleur body back with your right hand. Put the chain on top of the smallest freewheel sprocket.
- (3) On single-speed, remove the chain from the front sprocket, so that you have plenty of slack in the chain. Put the chain on the rear wheel sprocket.
- (4) Then, insert the wheel into the frame dropouts and pull it all the way in to the dropouts.

- (5) On a single speed or an internal-gear hub, replace the chain on the chainring; pull the wheel back in the dropouts so that it is straight in the frame and the chain has about 1/4 inches of up-and-down play.
- (6) With a cam action system, move the cam lever upwards and swing it into the CLOSED position (fig. 8a & b). The lever should now be parallel to the seat stay or chain stay and curved toward the wheel. To apply enough clamping force, you should have to wrap your fingers around the seat stay or chainstay for leverage, and the lever should leave a clear imprint in the palm of your hand.
- (7) With a through-bolt or bolt-on system, tighten the fasteners to the torque specifications in PART II "Tightening Torques" or the hub manufacturer's instructions.

NOTE:

If, on a traditional cam action system, the lever cannot be pushed all the way to a position parallel to the seat stay or chain stay, return the lever to the OPEN position. Then turn the tension-adjusting nut counterclockwise one-quarter turn and try tightening the lever again.

 **WARNING**

SECURELY CLAMPING THE WHEEL WITH A CAM ACTION RETENTION DEVICE TAKES CONSIDERABLE FORCE.

If you can fully close the cam lever without wrapping your fingers around the seat stay or chain stay for leverage, the lever does not leave a clear imprint in the palm of your hand, and the serrations on the wheel fastener do not emboss the surfaces of the dropouts, the tension is insufficient. Open the lever; turn the tension-adjusting nut clockwise a quarter turn; then try again.

See also WARNING on page 20.

(continued on next page...)

PART I

(continued from previous page...)

- 8) If you disengaged the brake quick-release mechanism in 3. c. (2) above, re-engage it to restore correct brake pad-to-rim clearance.
- 9) Spin the wheel to make sure that it is centered in the frame and clears the brake pads; then squeeze the brake lever and make sure that the brakes are operating correctly.

4.B. SEATPOST CAM ACTION CLAMP

Some bikes are equipped with a cam action seatpost binder. The seatpost cam action binder works exactly like the traditional wheel cam action fastener (Section 4.A.2). While a cam action binder looks like a long bolt with a lever on one end and a nut on the other, the binder uses an over-center cam action to firmly clamp the seatpost (see fig. 8a).

WARNING

Riding with an improperly tightened seatpost can allow the saddle to turn or move and cause you to lose control and fall. Therefore:

1. Ask REI to help you make sure you know how to correctly clamp your seatpost.
2. Understand and apply the correct technique for clamping your seatpost.
3. Before you ride the bike, first check that the seatpost is securely clamped.

Adjusting The Seatpost Cam Action Mechanism

The action of the cam squeezes the seat collar around the seatpost to hold the seatpost securely in place. The amount of clamping force is controlled by the tension-adjusting nut. Turning the tension-adjusting nut clockwise while keeping the cam lever from rotating increases clamping force; turning it counterclockwise while keeping the cam lever from rotating reduces clamping force. Less than half a turn of the tension-adjusting nut can make the difference between safe and unsafe clamping force.

WARNING

THE FULL FORCE OF THE CAM ACTION IS NEEDED TO CLAMP THE SEATPOST SECURELY.

Holding the nut with one hand and turning the lever like a wing nut with the other hand until everything is as tight as you can get it will not clamp the seatpost safely.

WARNING

If you can fully close the cam lever without wrapping your fingers around the seatpost or a frame tube for leverage, and the lever does not leave a clear imprint in the palm of your hand, the tension is insufficient. Open the lever; turn the tension-adjusting nut clockwise a quarter turn; then try again.

4.C - BRAKES

There are three general types of bicycle brakes: rim brakes, which operate by squeezing the wheel rim between two brake pads; disc brakes, which operate by squeezing a hub-mounted disc between two brake pads; and internal hub brakes. All three can be operated by way of a handlebar mounted lever. On some models of bicycle, the internal hub brake is operated by pedaling backwards. This is called a Coaster Brake and is described in "Coaster Brakes" in this section.

WARNING

1. Riding with improperly adjusted brakes or worn brake pads, or wheels on which the rim wear mark is visible is dangerous and can result in serious injury or death.
2. Applying brakes too hard or too suddenly can lock up a wheel, which could cause you to lose control and fall. Sudden or excessive application of the front brake may pitch the rider over the handlebars, which may result in serious injury or death.
3. Some bicycle brakes, such as disc brakes (fig. 11) and linear-pull brakes (fig.12), are extremely powerful. Take extra care in becoming familiar with these brakes and exercise particular care when using them.
4. Some bicycle brakes are equipped with a brake force modulator, a small, cylindrical device through which the brake control cable runs and which is designed to provide a more progressive application of braking force. A modulator makes the initial brake lever force more gentle, progressively increasing force until full force is achieved. If your bike is equipped with a brake force modulator, take extra care in becoming familiar with its performance characteristics.
5. Disc brakes can get extremely hot with extended use. Be careful not to touch a disc brake until it has had plenty of time to cool.
6. See the brake manufacturer's instructions for installation, operation and care of your brakes. If you do not have the manufacturer's instructions, see REI or contact the brake manufacturer.
7. If replacing worn or damaged parts, use only manufacturer-approved genuine replacement parts.

1. Brake Controls And Features

It's very important to your safety that you learn and remember which brake lever controls which brake on your bike.

Traditionally, in the U.S. the right brake lever controls the rear brake and the left brake lever controls the front brake; but, to check how your bike's brakes are set up, squeeze one brake lever and look to see which brake, front or rear, engages. Now do the same with the other brake lever.

Make sure that your hands can reach and squeeze the brake levers comfortably. If your hands are too small to operate the levers comfortably, consult REI before riding the bike. The lever reach may be adjustable; or you may need a different brake lever design.

Most rim brakes have some form of quick-release mechanism to allow the brake pads to clear the tire when a wheel is removed or reinstalled. When the brake quick release is in the open position, the brakes are inoperative. Ask REI to make sure that you understand the way the brake quick release works on your bike (see figs. 12, 13, 14 & 15) and check each time to make sure both brakes work correctly before you get on the bike.

2. How Brakes Work

The braking action of a bicycle is a function of the friction between the brake surfaces—usually the brake pads and the wheel rim. To make sure that you have maximum friction available, keep your wheel rims and brake pads clean and free of dirt, lubricants, waxes or polishes.

(continued on next page...)

PART I

(continued from previous page...)

Brakes are designed to control your speed, not just to stop the bike. Maximum braking force for each wheel occurs at the point just before the wheel “locks up” (stops rotating) and starts to skid. Once the tire skids, you actually lose most of your stopping force and all directional control. You need to practice slowing and stopping smoothly without locking up a wheel. The technique is called progressive brake modulation. Instead of jerking the brake lever to the position where you think you’ll generate appropriate braking force, squeeze the lever, progressively increasing the braking force. If you feel the wheel begin to lock up, release pressure just a little to keep the wheel rotating just short of lockup.

It’s important to develop a feel for the amount of brake lever pressure required for each wheel at different speeds and on different surfaces. To better understand this, experiment a little by walking your bike and applying different amounts of pressure to each brake lever, until the wheel locks.

When you apply one or both brakes, the bike begins to slow, but your body wants to continue at the speed at which it was going. This causes a transfer of weight to the front wheel (or, under heavy braking, around the front wheel hub, which could send you flying over the handlebars).

A wheel with more weight on it will accept greater brake pressure before lockup; a wheel with less weight will lock up with less brake pressure. So, as you apply brakes and your weight is transferred forward, you need to shift your body toward the rear of the bike, to transfer weight back onto the rear wheel; and at the same time, you need to both decrease rear braking and increase front braking force. This is even more important on descents, because descents shift weight forward.

Two keys to effective speed control and safe stopping are controlling wheel lockup and weight transfer. This weight transfer is even more pronounced if your bike has a front suspension fork. Front suspension “dips” under braking, increasing the weight transfer (see also SECTION 4.F). Practice braking and weight transfer techniques where there is no traffic or other hazards and distractions.

Everything changes when you ride on loose surfaces or in wet weather. Tire adhesion is reduced, so the wheels have less cornering and braking traction and can lock up with less brake force. Moisture or dirt on the brake pads reduces their ability to grip. The way to maintain control on loose or wet surfaces is to go more slowly.

More info:

ROAD BIKES: DISC BRAKES

Now, go to PART II of this manual and read “Understanding Disc Brakes on Road Bikes”

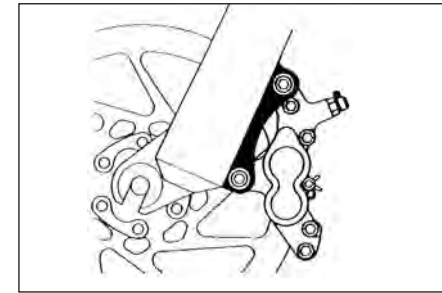

Figure 11.

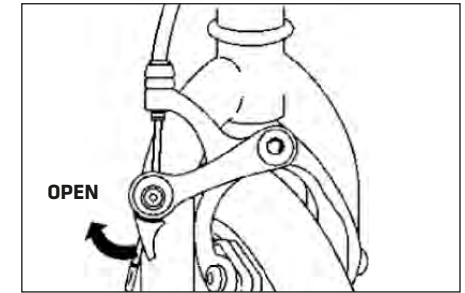

Figure 14.

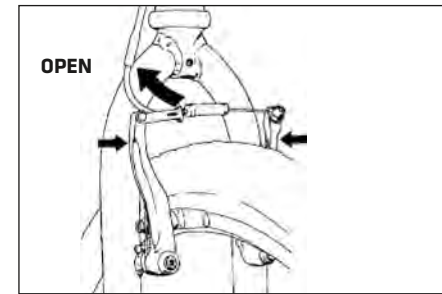

Figure 12.

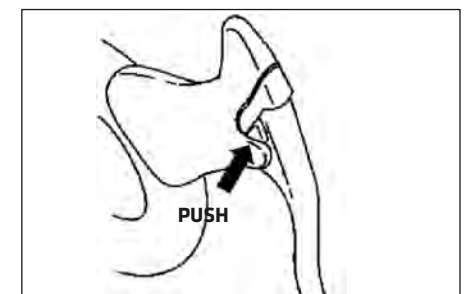

Figure 15.

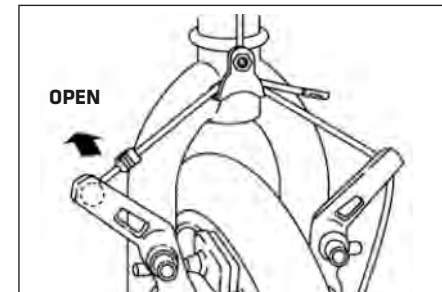
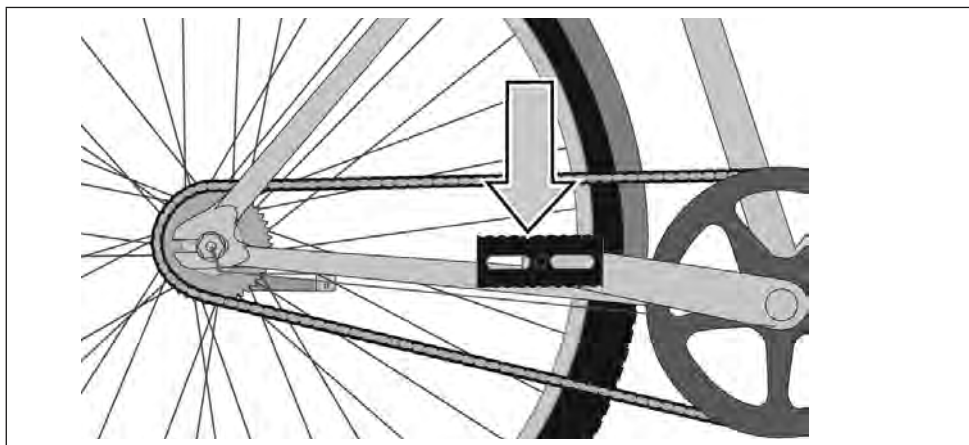

Figure 13.

PART I

COASTER BRAKES



1. How the coaster brake works

The coaster brake is a sealed mechanism which is a part of the bicycle's rear wheel hub. The brake is activated by reversing the rotation of the pedal cranks (indicated by arrow above). Start with the pedal cranks in a nearly horizontal position, with the front pedal in about the 4 o'clock position, and apply downward foot pressure on the pedal that is to the rear. About 1/8 turn rotation will activate the brake. The more downward pressure you apply, the more braking force, up to the point where the rear wheel stops rotating and begins to skid.

WARNING

Before riding, make sure that the brake is working properly. If it is not working properly, have the bicycle checked by REI before you ride it.

WARNING

If your bike has only a coaster brake, ride conservatively. A single rear brake does not have the stopping power of front-and-rear brake systems.

2. Adjusting your coaster brake

Coaster brake service and adjustment requires special tools and special knowledge. Do not attempt to disassemble or service your coaster brake. Take the bicycle to REI for coaster brake service.

4.D - SHIFTING GEARS

Your multi-speed bicycle will have a derailleur drivetrain (see 1. below), an internal gear hub drivetrain (see 2. below) or, in some special cases, a combination of the two.

1. How a derailleur drivetrain works

If your bicycle has a derailleur drivetrain, the gear-changing mechanism will have:

- a rear cassette or freewheel sprocket cluster
- a rear derailleur
- usually a front derailleur
- one or two shifters
- one, two or three front sprockets called chainrings
- a drive chain

a. Shifting Gears

There are several different types and styles of shifting controls: levers, twist grips, triggers, combination shift/brake controls, push-buttons, and so on. Ask REI to explain the type of shifting controls that are on your bike, and to show you how they work.

The vocabulary of shifting can be pretty confusing. A downshift is a shift to a "lower" or "slower" gear, one which is easier to pedal. An upshift is a shift to a "higher" or "faster", harder to pedal gear. What's confusing is that what's happening at the front derailleur is the opposite of what's happening at the rear derailleur (for details, read the instructions on Shifting the Rear Derailleur and Shifting the Front Derailleur below).

For example, you can select a gear which will make pedaling easier on a hill (make a downshift) in one of two ways: shift the chain down the gear "steps" to a smaller gear at the front, or up the gear "steps" to a larger gear at the rear. So, at the rear gear cluster, what is called a downshift looks like an upshift. The way to keep things straight is to remember that shifting the chain in towards the centerline of the bike is for accelerating and climbing and is called a downshift. Moving the chain out or away from the centerline of the bike is for speed and is called an upshift.

Whether upshifting or downshifting, the bicycle derailleur system design requires that the drive chain be moving forward and be under at least some tension. A derailleur will shift only if you are pedaling forward.

CAUTION

Never move the shifter while pedaling backward, nor pedal backwards immediately after having moved the shifter. This could jam the chain and cause serious damage to the bicycle.

b. Shifting the Rear Derailleur

The rear derailleur is controlled by the right shifter.

The function of the rear derailleur is to move the drive chain from one gear sprocket to another. The smaller sprockets on the gear cluster produce higher gear ratios. Pedaling in the higher gears requires greater pedaling effort, but takes you a greater distance with each revolution of the pedal cranks. The larger sprockets produce lower gear ratios. Using them requires less pedaling effort, but takes you a shorter distance with each pedal crank revolution. Moving the chain from a smaller sprocket of the gear cluster to a larger sprocket results in a downshift. Moving the chain from a larger sprocket to a smaller sprocket results in an upshift. In order for the derailleur to move the chain from one sprocket to another, the rider must be pedaling forward.

c. Shifting the Front Derailleur:

The front derailleur, which is controlled by the left shifter, shifts the chain between the larger and smaller chainrings. Shifting the chain onto a smaller chainring makes pedaling easier (a downshift). Shifting to a larger chainring makes pedaling harder (an upshift).

PART I

d. Which gear should I be in?

The combination of largest rear and smallest front gears (fig. 16) is for the steepest hills. The smallest rear and largest front combination is for the greatest speed. It is not necessary to shift gears in sequence. Instead, find the “starting gear” which is right for your level of ability—a gear which is hard enough for quick acceleration but easy enough to let you start from a stop without wobbling—and experiment with upshifting and downshifting to get a feel for the different gear combinations. At first, practice shifting where there are no obstacles, hazards or other traffic, until you’ve built up your confidence. Learn not to use either the “smallest-to-smallest” or “largest-to-largest” gear combinations because they can cause unacceptable stress on the drivetrain. Learn to anticipate the need to shift, and shift to a lower gear before the hill gets too steep. If you have difficulties with shifting, the problem could be mechanical adjustment. See REI for help.

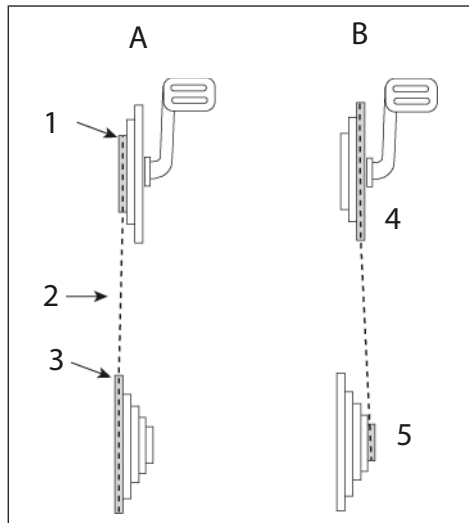

Figure 16.

- | | |
|-------------------|-------------------|
| A. Hills | B. Greatest Speed |
| 1. Smallest front | 4. Largest front |
| 2. Chain | 5. Smallest rear |
| 3. Largest rear | |

WARNING

NEVER SHIFT A DERAILLEUR ONTO THE LARGEST OR THE SMALLEST SPROCKET IF THE DERAILLEUR IS NOT SHIFTING SMOOTHLY.

The derailleur may be out of adjustment and the chain could jam, causing you to lose control and fall.

e. What if it won't shift gears?

If moving the shift control one click repeatedly fails to result in a smooth shift to the next gear, chances are that the mechanism is out of adjustment. Take the bike to REI to have it adjusted.

2. How an internal-gear hub drivetrain works

If your bicycle has an internal-gear hub drivetrain, the gear changing mechanism will consist of:

- a 3, 5, 7, 8, 12 speed or possibly an infinitely variable internal-gear hub
- one, or sometimes two shifters
- one or two control cables
- one front sprocket called a chainring
- a drive chain

a. Shifting internal-gear hub gears

Shifting with an internal-gear hub drivetrain is simply a matter of moving the shifter to the indicated position for the desired gear. After you have moved the shifter to the gear position of your choice, ease the pressure on the pedals for an instant to allow the hub to complete the shift.

b. Which gear should I be in?

The numerically lowest gear (1) is for the steepest hills. The numerically largest gear is for the greatest speed.

Shifting from an easier, “slower” gear (like 1) to a harder, “faster” gear (like 2 or 3) is called an upshift. Shifting from a harder, “faster” gear to an easier, “slower” gear is called a downshift. It is not necessary to shift gears in sequence. Instead, find the “starting gear” for the conditions—a gear which is hard enough for quick acceleration but easy enough to let you start from a stop without wobbling—and experiment with upshifting and downshifting to get a feel for the different gears. At first, practice shifting where there are no obstacles, hazards or other traffic, until you’ve built up your confidence. Learn to anticipate the need to shift, and shift to a lower gear before the hill gets too steep. If you have difficulties with shifting, the problem could be mechanical adjustment. See REI for help.

c. What if it won't shift gears?

If moving the shift control one click repeatedly fails to result in a smooth shift to the next gear chances are that the mechanism is out of adjustment. Take the bike to REI to have it adjusted.

4.E - PEDALS

1. Toe overlap is when your toe can touch the front wheel when you turn the handlebar to steer while a pedal is in the forwardmost position. This is common on small-framed bicycles, and is avoided by keeping the inside pedal up and the outside pedal down when making sharp turns. This technique will also prevent the inside pedal from striking the ground in a turn.

WARNING

TOE OVERLAP COULD CAUSE YOU TO LOSE CONTROL AND FALL. ASK REI TO HELP YOU DETERMINE IF THE COMBINATION OF FRAME SIZE, CRANK ARM LENGTH, PEDAL DESIGN AND SHOES YOU WILL USE RESULTS IN PEDAL OVERLAP.

Whether you have overlap or not, you must keep the inside pedal up and the outside pedal down when making sharp turns.

2. Some bicycles come equipped with pedals that have sharp and potentially dangerous surfaces. These surfaces are designed to add safety by increasing grip between the rider's shoe and

the pedal. If your bicycle has this type of high-performance pedal, you must take extra care to avoid serious injury from the pedals' sharp surfaces. Based on your riding style or skill level, you may prefer a less aggressive pedal design, or chose to ride with shin pads. REI can show you a number of options and make suitable recommendations.

3. Toeclips and straps are a means to keep feet correctly positioned and engaged with the pedals. The toeclip positions the ball of the foot over the pedal spindle, which gives maximum pedaling power. The toe strap, when tightened, keeps the foot engaged throughout the rotation cycle of the pedal. While toeclips and straps give some benefit with any kind of shoe, they work most effectively with cycling shoes designed for use with toeclips. REI can explain how toeclips and straps work. Shoes with deep treaded soles or welts which might allow the foot to be trapped should not be used with toeclips and straps.

WARNING

GETTING INTO AND OUT OF PEDALS WITH TOECLIPS AND STRAPS REQUIRES SKILL WHICH CAN ONLY BE ACQUIRED WITH PRACTICE.

Until it becomes a reflex action, the technique requires concentration which can distract your attention and cause you to lose control and fall.

Practice the use of toeclips and straps where there are no obstacles, hazards or traffic. Keep the straps loose, and don't tighten them until your technique and confidence in getting in and out of the pedals warrants it. Never ride in traffic with your toe straps tight.

4. Clipless pedals (sometimes called “step-in pedals”) are another means to keep feet securely in the correct position for maximum pedaling efficiency. They have a plate, called a “cleat,” on the sole of the shoe, which clicks into a mating spring-loaded fixture on the pedal.

(continued on next page...)

PART I

(continued from previous page...)

They only engage or disengage with a very specific motion which must be practiced until it becomes instinctive. Clipless pedals require shoes and cleats which are compatible with the make and model pedal being used.

Many clipless pedals are designed to allow the rider to adjust the amount of force needed to engage or disengage the foot. Follow the pedal manufacturer's instructions, or ask REI to show you how to make this adjustment. Use the easiest setting until engaging and disengaging becomes a reflex action, but always make sure that there is sufficient tension to prevent unintended release of your foot from the pedal.

WARNING

CLIPLESS PEDALS ARE INTENDED FOR USE WITH SHOES SPECIFICALLY MADE TO FIT THEM AND ARE DESIGNED TO FIRMLY KEEP THE FOOT ENGAGED WITH THE PEDAL.

DO NOT USE SHOES WHICH DO NOT ENGAGE THE PEDALS CORRECTLY.

Practice is required to learn to engage and disengage the foot safely. Until engaging and disengaging the foot becomes a reflex action, the technique requires concentration which can distract your attention and cause you to lose control and fall. Practice engaging and disengaging clipless pedals in a place where there are no obstacles, hazards or traffic; and be sure to follow the pedal manufacturer's setup and service instructions. If you do not have the manufacturer's instructions, see REI or contact the manufacturer.

4.F - BICYCLE SUSPENSION

Many bicycles are equipped with suspension systems. There are many different types of suspension systems—too many to deal with individually in this Manual. If your bicycle has a suspension system of any kind, be sure to read and follow the suspension manufacturer's setup and service instructions. If you do not have the manufacturer's instructions, see REI or contact the manufacturer.

WARNING

FAILURE TO MAINTAIN, CHECK AND PROPERLY ADJUST THE SUSPENSION SYSTEM MAY RESULT IN SUSPENSION MALFUNCTION, WHICH MAY CAUSE YOU TO LOSE CONTROL AND FALL.

If your bike has suspension, the increased speed you may develop also increases your risk of injury. For example, when braking, the front of a suspended bike dips. You could lose control and fall if you do not have experience with this system. Learn to handle your suspension system safely. See also SECTION 4.C.

WARNING

CHANGING SUSPENSION ADJUSTMENT CAN CHANGE THE HANDLING AND BRAKING CHARACTERISTICS OF YOUR BICYCLE.

Never change suspension adjustment unless you are thoroughly familiar with the suspension system manufacturer's instructions and recommendations, and always check for changes in the handling and braking characteristics of the bicycle after a suspension adjustment by taking a careful test ride in a hazard-free area.

Suspension can increase control and comfort by allowing the wheels to better follow the terrain. This enhanced capability may allow you to ride faster, but you must not confuse the enhanced capabilities of the bicycle with your own capabilities as a rider. Increasing your skill will take time and practice. Proceed carefully until you have learned to handle the full capabilities of your bike.

WARNING

Not all bicycles can be safely retrofitted with some types of suspension systems. Before retrofitting a bicycle with any suspension, check with the bicycle's manufacturer to make sure that what you want to do is compatible with the bicycle's design. Failing to do so can result in catastrophic frame failure.

4.G TIRES AND TUBES

1. Tires

Bicycle tires are available in many designs and specifications, ranging from general-purpose designs to tires designed to perform best under very specific weather or terrain conditions. If, once you've gained experience with your new bike, you feel that a different tire might better suit your riding needs, REI can help you select the most appropriate design.

The size, pressure rating, and on some high-performance tires the specific recommended use, are marked on the sidewall of the tire (see fig. 17). The part of this information that is most important to you is tire pressure. But some wheel rim manufacturers also specify maximum tire pressure with a label on the rim.

WARNING

NEVER INFLATE A TIRE BEYOND THE MAXIMUM PRESSURE MARKED ON THE TIRE'S SIDEWALL OR THE WHEEL RIM.

If the maximum pressure rating for the wheel rim is lower than the maximum pressure shown on the tire, always use the lower rating. Exceeding the recommended maximum pressure may blow the tire off the rim or damage the wheel rim, which could cause damage to the bike and injury to the rider and bystanders.

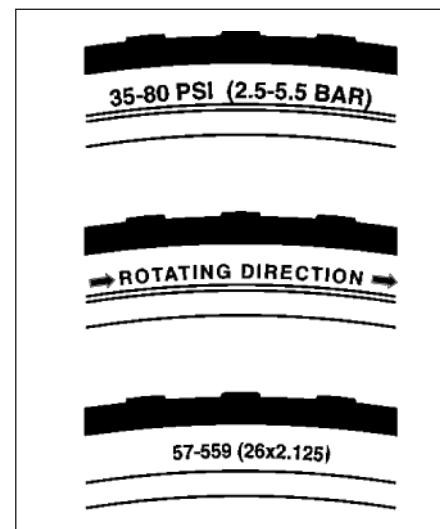

Figure 17.

The best and safest way to inflate a bicycle tire to the correct pressure is with a bicycle pump which has a built-in pressure gauge.

(continued on next page...)

PART I

(continued from previous page...)

WARNING

THERE IS A SAFETY RISK IN USING GAS STATION AIR HOSES OR OTHER AIR COMPRESSORS.

They are not made for bicycle tires. They move a large volume of air very rapidly, and will raise the pressure in your tire very rapidly, which could cause the tube to explode.

Tire pressure is given either as maximum pressure or as a pressure range. How a tire performs under different terrain or weather conditions depends largely on tire pressure. Inflating the tire to near its maximum recommended pressure gives the lowest rolling resistance, but also produces the harshest ride. High pressures work best on smooth, dry pavement.

Very low pressures, at the bottom of the recommended pressure range, give the best performance on smooth, slick terrain such as hard-packed clay, and on deep, loose surfaces such as deep, dry sand.

Tire pressure that is too low for your weight and the riding conditions can cause a puncture of the tube by allowing the tire to deform sufficiently to pinch the inner tube between the rim and the riding surface.

CAUTION

Pencil-type automotive tire gauges can be inaccurate and should not be relied upon for consistent, accurate pressure readings. Instead, use a high quality dial gauge.

Ask REI to recommend the best tire pressure for the kind of riding you will most often do, and have the local REI inflate your tires to that pressure. Then, check inflation as described in SECTION 1.C so you'll know how correctly inflated tires should look and feel when you don't have access to a gauge.

Some tires may need to be brought up to pressure every week or two. So, it is important to check your tire pressures before every ride.

Some special high-performance tires have unidirectional treads: their tread pattern is designed to work better in one direction than in the other. The sidewall marking of a unidirectional tire will have an arrow showing the correct rotation direction. If your bike has unidirectional tires, be sure that they are mounted to rotate in the correct direction.

2. Tire Valves

There are primarily two kinds of bicycle tube valves: The Schrader Valve and the Presta Valve. The bicycle pump you use must have the fitting appropriate to the valve stems on your bicycle.

The Schrader valve (fig. 18) is like the valve on a car tire. To inflate a Schrader valve tube, remove the valve cap and clamp the pump fitting onto the end of the valve stem. To let air out of a Schrader valve, depress the pin in the end of the valve stem with the end of a key or other appropriate object.

The Presta valve (fig. 18) has a narrower diameter and is only found on bicycle tires. To inflate a Presta valve tube using a Presta headed bicycle pump, remove the valve cap; unscrew (counterclockwise) the valve stem lock nut, and push down on the valve stem to free it up. Then push the pump head on to the valve head, and inflate. To inflate a Presta valve with a Schrader pump fitting, you'll need a Presta adapter (available at your bike shop) which screws on to the valve stem once you've freed up the valve. The adapter fits into the Schrader pump fitting. Close the valve after inflation. To let air out of a Presta valve, open up the valve stem lock nut and depress the valve stem.

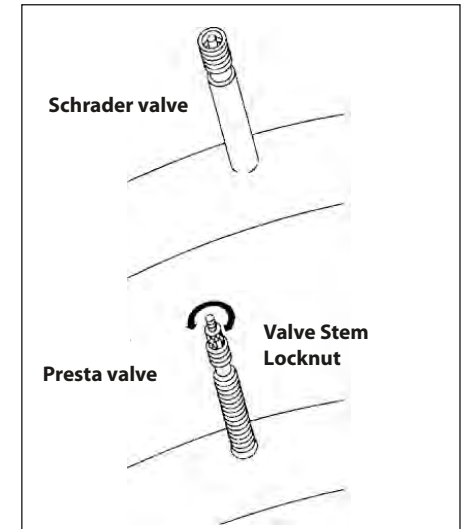

Figure 18.

WARNING

We highly recommend that you carry a spare inner tube when you ride your bike.

PATCHING A TUBE IS AN EMERGENCY REPAIR.

If you do not apply the patch correctly or apply several patches, the tube can fail, resulting in possible tube failure, which could cause you to lose control and fall. Replace a patched tube as soon as possible.

PART I

SECTION 5. SERVICE

WARNING

TECHNOLOGICAL ADVANCES HAVE MADE BICYCLES AND BICYCLE COMPONENTS MORE COMPLEX, AND THE PACE OF INNOVATION IS INCREASING.

IT IS IMPOSSIBLE FOR THIS MANUAL TO PROVIDE ALL THE INFORMATION REQUIRED TO PROPERLY REPAIR AND/OR MAINTAIN YOUR BICYCLE.

In order to help minimize the chances of an accident and possible injury, it is critical that you have any repair or maintenance which is not specifically described in this manual performed by REI. Equally important is that your individual maintenance requirements will be determined by everything from your riding style to geographic location.

Consult REI for help in determining your maintenance requirements.

WARNING

MANY BICYCLE SERVICE AND REPAIR TASKS REQUIRE SPECIAL KNOWLEDGE AND TOOLS.

Do not begin any adjustments or service on your bicycle until you have learned from REI how to properly complete them. Improper adjustment or service may result in damage to the bicycle or in an accident which can cause serious injury or death.

If you want to learn to do major service and repair work on your bike, you have three options:

1. Ask REI for copies of the manufacturer's installation and service instructions for the components on your bike, or contact the component manufacturer.
2. Ask REI to recommend a book on bicycle repair.
3. Ask REI about the availability of bicycle repair courses in your area.

We recommend that you ask REI to check the quality of your work the first time you work on something and before you ride the bike, just to make sure that you did everything correctly. Since that will require the time of a mechanic, there may be a modest charge for this service.

We also recommend that you ask REI for guidance on what spare parts, such as inner tubes, light bulbs, etc. it would be appropriate for you to have once you have learned how to replace such parts when they require replacement.

5.A - SERVICE INTERVALS

Some service and maintenance can and should be performed by the owner and require no special tools or knowledge beyond what is presented in this manual.

The following are examples of the type of service you should perform yourself. All other service, maintenance and repair should be performed in a properly equipped facility by a qualified bicycle mechanic using the correct tools and procedures specified by the manufacturer.

1. **BREAK-IN PERIOD:** Your bike will last longer and work better if you break it in before riding it hard. Control cables and wheel spokes may stretch or "seat" when a new bike is first used and may require readjustment by REI. Your Mechanical Safety Check (SECTION 1.C) will help you identify some things that need readjustment. But even if everything seems fine to you, it's best to take your bike back to the local REI for a checkup.

We typically suggest you bring the bike in for a 30-day checkup.

Another way to judge when it's time for the first checkup is to bring the bike in after three to five hours of hard off-road use, or about 10 to 15 hours of on-road or more casual off-road use. But if you think something is wrong with the bike, take it to REI before riding it again.

2. **BEFORE EVERY RIDE:** Mechanical Safety Check (SECTION 1.C)
3. **AFTER EVERY LONG OR HARD RIDE:** If the bike has been exposed to water or grit; or at least every 100 miles: Clean the bike and lightly lubricate the chain's rollers with a good quality bicycle chain lubricant. Wipe off excess lubricant with a lint-free cloth. Lubrication is a function of climate. Talk to REI about the best lubricants and the recommended lubrication frequency for your area.

4. AFTER EVERY LONG OR HARD RIDE OR AFTER EVERY 10 TO 20 HOURS OF RIDING:

- Squeeze the front brake and rock the bike forward and back. Everything feel solid? If you feel a clunk with each forward or backward movement of the bike, you probably have a loose headset. Have REI check it.
- Lift the front wheel off the ground and swing it from side to side. Feel smooth? If you feel any binding or roughness in the steering, you may have a tight headset. Have REI check it.
- Grab one pedal and rock it toward and away from the center line of the bike; then do the same with the other pedal. Anything feel loose? If so, have REI check it.
- Take a look at the brake pads. Starting to look worn or not hitting the wheel rim squarely? Time to have the local REI adjust or replace them.
- Carefully check the control cables and cable housings. Any rust? Kinks? Fraying? If so, have REI replace them.
- Squeeze each adjoining pair of spokes on either side of each wheel between your thumb and index finger. Do they all feel about the same? If any feel loose, have REI check the wheel for tension and trueness.
- Check the tires for excess wear, cuts or bruises. Have REI replace them if necessary.
- Check the wheel rims for excess wear, dings, dents, and scratches. Consult REI if you see any rim damage.
- Check to make sure that all parts and accessories are still secure, and tighten any that are not.

(continued on next page...)

PART I

(continued from previous page...)

- Check the frame, particularly in the area around all tube joints; the handlebar; the stem; and the seatpost for any deep scratches, cracks or discoloration. These are signs of stress-caused fatigue and indicate that a part is at the end of its useful life and needs to be replaced. **See also PART II, SECTION D. INSPECT FOR SAFETY.**
- 5. **AS REQUIRED:** If either brake lever fails the Mechanical Safety Check (SECTION 1.C), don't ride the bike. Have REI check the brakes. If the chain won't shift smoothly and quietly from gear to gear, the derailleur is out of adjustment. See REI.
- 6. **EVERY 25 (HARD OFF-ROAD) TO 50 (ON-ROAD) HOURS OF RIDING:** Take your bike to REI for a complete checkup.

WARNING

LIKE ANY MECHANICAL DEVICE, A BICYCLE AND ITS COMPONENTS ARE SUBJECT TO WEAR AND STRESS. DIFFERENT MATERIALS AND MECHANISMS WEAR OR FATIGUE FROM STRESS AT DIFFERENT RATES AND HAVE DIFFERENT LIFE CYCLES.

IF A COMPONENT'S LIFE CYCLE IS EXCEEDED, THE COMPONENT CAN SUDDENLY AND CATASTROPHICALLY FAIL, CAUSING SERIOUS INJURY OR DEATH TO THE RIDER.

Scratches, cracks, fraying and discoloration are signs of stress-caused fatigue and indicate that a part is at the end of its useful life and needs to be replaced. While the materials and workmanship of your bicycle or of individual components may be covered by a warranty for a specified period of time by the manufacturer, this is no guarantee that the product will last the term of the warranty.

Product life is often related to the kind of riding you do and to the treatment to which you submit the bicycle.

The bicycle's warranty is not meant to suggest that the bicycle cannot be broken or will last forever. It only means that the bicycle is covered subject to the terms of the warranty.

Please be sure to read PART II, SECTION D. INSPECT FOR SAFETY, "The Lifespan of Your Bicycle and Its Components."

5.B - IF YOUR BICYCLE SUSTAINS AN IMPACT:

First, check yourself for injuries and take care of them as best you can. Seek medical help if necessary.

Next, check your bike for damage.

After any crash, take your bike to REI for a thorough check.

Carbon composite components, including frames, wheels, handlebar, stems, cranksets, brakes, etc. which have sustained an impact must not be ridden until they have been disassembled and thoroughly inspected by a qualified mechanic.

See also Bicycle Lifespan on page 76.

WARNING

A CRASH OR OTHER IMPACT CAN PUT EXTRAORDINARY STRESS ON BICYCLE COMPONENTS, CAUSING THEM TO FATIGUE PREMATURELY. COMPONENTS SUFFERING FROM STRESS FATIGUE CAN FAIL SUDDENLY AND CATASTROPHICALLY, CAUSING LOSS OF CONTROL, SERIOUS INJURY OR DEATH.

SECTION A. IMPORTANT SAFETY INFORMATION

A WIDE RANGE OF BICYCLING INJURIES ARE POSSIBLE

Many hazards are described, and we have attempted to explain how to avoid or minimize the dangers. Because any fall can result in serious injury, paralysis or death, we do not repeat the warning of these potential consequences every time we call attention to a hazard. Some low-speed falls may result in serious injuries, and some wild, high-speed falls may result in none. The reality is that the exact nature of the consequences of a fall or accident are not predictable.

BICYCLES CANNOT PROTECT YOU

Bicycles are lightweight, human-powered vehicles. Unlike a car and much like a motorcycle, there is no restraint system for your body, no protective structure around your body. Crash-worthiness cannot be a design criterion. A rider sits on a bicycle and can be easily thrown off for many reasons, including overly hard use of the front brakes (See PART I, Section 4.C: Brakes) or striking an obstacle.

A.1 - BICYCLING-INHERENT RISK

⚠ WARNING

BICYCLING IS AN ACTIVE SPORT WITH INHERENT RISK, AND THE SITUATIONS YOU ENCOUNTER WHILE RIDING EXPOSE YOU TO THE RISK OF SERIOUS INJURY OR DEATH.

The risk cannot be taken away or eliminated. You can minimize risk by doing the following:

- Bicycle training and practice
- Progressive step-by-step learning of new cycling skills
- The good judgment to ride in control
- Bicycle experience; riding with experienced riders
- Use of a proper bicycle helmet and appropriate protective gear
- Reading and thinking about this entire owner's manual; all owner's manual supplements and instructions that came with your bicycle are essential to your safety and part of the learning process
- Riding within your own unique capabilities and considering the conditions where you are riding

WARNING LABEL

We urge you to locate the warning label on your bike. It contains important information that you and anyone else who rides your bike should read and follow.

Do not remove it. If you bought an older bike or are refinishing one of our bikes, contact us for a no-charge replacement.



Figure 19.

RIDING IN TRAFFIC, COMMUTING

⚠ WARNING

RIDING IN TRAFFIC (AND COMMUTING) IS HAZARDOUS AND YOU CAN BE SEVERELY INJURED OR KILLED DOING IT.

As noted in PART I of this manual, you must learn and obey local traffic laws. Riding in traffic is hazardous. We cannot teach you about all of these hazards.

Here are just some important topics you must consider:

Traffic Law, Accidents, Intersections, Commuting And Utility Cycling Where To Ride, On Roadway, Changing Lanes In Traffic, Riding At Night, Improving Your Odds With Safety, Lighting , And Weather Equipment

REI and many bike clubs conduct training programs and workshops that focus on these and other safe cycling topics. Seek the advice of an experienced bicycle commuter at REI.

WARNING**RIDING AT NIGHT/DUSK OR AT DAWN IS VERY HAZARDOUS.**

Avoid riding at night. If you choose to ride at night:

Install front and rear lights.

Install a blinker or strobe light.

Check your state or national laws. Lights are required for riding at dusk, night, or dawn.

Wear reflective clothing.

Stay alert, others may not see you.

Make sure your bicycle is equipped with all required reflectors, lights, strobes, or blinkers.

Required Reflectors

The location and type of each reflector on your bike is required by a national authority, in the U.S., the U.S. Consumer Product Safety Commission (CPSC). Your Co-op Cycles bike must be delivered with: 1. A front-mounted, forward-facing reflector 2. A rear-mounted, rear-facing reflector, 3. A spoke-mounted reflector on each wheel, 4. Front- and rear-facing reflectors on the left and right pedal. **DO NOT REMOVE, BLOCK, OR COVER REFLECTORS.**

Much Higher Risks At Night

The risk of an accident, particularly being struck by a motor vehicle, is much higher at night. If you choose to accept this higher risk, improve your odds with a proper lighting system, strobe light, light-colored reflective clothing and careful riding. Seek the advice of an experienced bicycle commuter at REI.

Mountain Biking At Night:

Mountain biking at night is risky. Take the challenges outlined in SECTION C. and add another level of difficulty and risk. Seeing the terrain is much more difficult at night. Mountain biking at night is only for skilled mountain bikers, on familiar terrain, with excellent light systems, riding with other skilled mountain bikers, and riding cautiously.

Adding Lighting:

Reflectors are not a substitute for proper lights. It is your responsibility to equip your bicycle with all national, state and locally mandated lights.

Riding at dawn, at dusk, at night or at other times of poor visibility without a bicycle lighting system which meets local and state laws and without reflectors is dangerous and may result in serious injury or death.

If you ride your bike before dawn or after dusk, your bicycle must be equipped with lights so that you can see the road and avoid road hazards, and so that others can see you. Traffic laws treat bicycles like any other vehicle. That means you must have a white front and a red rear light operating if you are riding after dusk. REI can recommend a battery- or generator-powered lighting system appropriate to your needs.

Flashing (blinker) and Strobe Lighting

We also strongly urge you to use a flashing light or strobe at night or in conditions of lower visibility. (Note: there may be legal issues with flashers in some areas. Consulting local regulations is recommended.)

WARNING

1. Incorrectly refinishing or repainting your bike can lead to a serious accident.
2. Refinishing could hide structural damage (fatigue cracks, dented or bent tubes, or other structural problems) also leading to an accident. You can be injured or killed.

PRECAUTIONS:

- Chemicals that might be used in refinishing might attack your frame and/or fork (carbon fiber) and weaken them.
- Removing original paint, decals (sanding, scouring, scratching, or blasting) can actually remove frame material, possibly weakening them.
- Refinishing cannot fix structural problems; refinishing might conceal serious damage.

WARNING**DO NOT MODIFY YOUR BIKE FRAME, FORK OR COMPONENTS IN ANY WAY.****MODIFICATIONS CAN CAUSE DAMAGE LEADING TO FAILURE AND ACCIDENT.****YOU CAN BE SEVERELY INJURED OR KILLED.**

Do not physically alter your frame or fork in any way. Don't sandblast, shot blast or glass bead your frame and fork. Don't use any coarse sandpaper on your bike. Don't grind, wire brush, file, scrape or machine buff your frame and fork. Don't weld, braze or let anyone touch your frame and fork with a torch. Don't drill any holes in your frame and fork. Don't acid dip or etch your frame and fork. Don't anodize or chrome plate your frame and fork. Any of these procedures will seriously harm the structural integrity and/or longevity of your frame and fork, which could lead to serious accident and injury.

Modifications will void any applicable warranty.

CHILD CARRIERS

WARNING

CHILD CARRIERS ADD WEIGHT AND RAISE THE CENTER OF GRAVITY MAKING BALANCE AND CORNERING MORE DIFFICULT. IF YOU LOSE CONTROL, YOU AND YOUR CHILD PASSENGER CAN BE SEVERELY INJURED OR KILLED.

If you choose to install a child carrier, have an experienced bicycle mechanic install it. Install only on a compatible bicycle. If you insist on using a child carrier, we urge that you confirm with both the carrier rack manufacturer and the child carrier manufacturer that the two products are safely compatible. Always use caution when riding with a child carrier.

Some saddles are equipped with coil springs. If you use a rear-rack-mounted child carrier, there is a risk that a child's fingers could be injured if trapped in the coil springs when the rider hits a bump and the springs compress. Be sure that the child cannot reach the springs when properly strapped in the carrier.

If you choose to use trailers for children, be very careful when towing a trailer. Remember that braking distances increase, and the trailer will track inside the line of the bicycle when making turns. Children should always wear helmets when riding in a child carrier or trailer. Use of bicycle helmets on children is required by law in many areas.

WARNING

Co-op children's bikes are equipped with handlebar end plugs under the hand grips. If the plug gets damaged and no longer blocks the open end of the handlebar, the bike should be brought back to an REI store so a new plug can be installed. Failure to block the open end of the handlebar could result in serious injury or death.

BICYCLES HAVE SHARP SURFACES

WARNING

BICYCLES HAVE EXPOSED SHARP SURFACES.

Exercise caution with chainrings and pointed, aggressive platform pedals, as they have sharp and potentially dangerous surfaces. Use caution when working on your bike. If you slip or fall you could be injured.

BAR ENDS

If you choose to install "Bar Ends" on bicycles, have an experienced bicycle mechanic install them. Some handlebars are designed to take the added stress of bar ends, others are not. Very lightweight handlebars may be particularly poorly suited for bar ends. If you want bar ends, consult REI about suitable choices, read and follow instructions and warnings that accompany the handlebar and bar ends, and inspect the handlebar and bar ends regularly.

INSTALLING ACCESSORIES

Have all accessories mounted by REI. Be sure that any accessory you or REI fits to your bike does not block or interfere with nationally required reflectors or lights.

WARNING

INCOMPATIBLE ACCESSORIES OR POORLY OR IMPROPERLY MOUNTED ACCESSORIES CAN ADVERSELY AFFECT THE PERFORMANCE OF YOUR BICYCLE AND MAY BE UNSAFE.

AERODYNAMIC HANDLEBARS

Aerodynamic or "Triathlon" handlebar extensions are fitted to some triathlon or racing bikes. They are also added by customers. Understand that when riding on these extensions, your steering and braking are adversely affected. When on the extensions, most riders find it hard to look back over their shoulder without swerving, inadvertently steering. Some riders find it harder to move their head/neck to see forward. Be sure to practice riding with aero handlebar extensions on hazard- and traffic-free roads. Practice the transition from having your hands on the extensions to having your hands on the regular handlebar and brake levers.

CONVENTIONAL ROAD

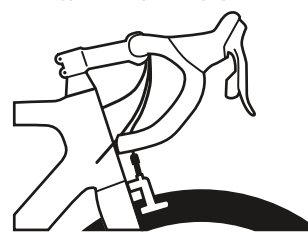

AERODYNAMIC extensions

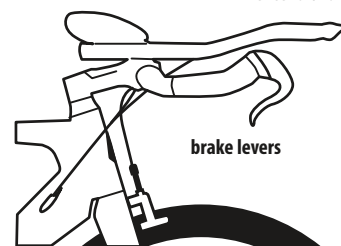

Lower/ forward on extensions



WARNING

DO NOT RIDE ON THE AERO HANDLEBAR EXTENSIONS IN TRAFFIC OR ON DIFFICULT ROADS.

Ride on the aero handlebar extensions only when the road is clear of traffic and hazards and you have a long line of sight.

When using the extensions understand that you are compromising steering and braking in favor of speed. If you need to take evasive steering or braking action while on the extensions you could have an accident, with risk of serious injury, paralysis or death.

Aerodynamic handlebars and extensions are a design trade-off which positions you further forward than on a conventional road bike, so:

Overly hard use of the front brakes will pitch you forward, off the bike, more easily.

Rear braking performance will not equal that of a conventional road bike.

When braking hard on any bike, including time trial or triathlon, you must shift weight back to allow front brake use without pitching yourself forward, off the bike. Shifting weight back allows more rear braking effect before the rear wheel begins to skid when braking hard, or braking on a steep downhill. See PART 1 Section 4C. of this manual.

Aerodynamic handlebars and extensions are intended for racing and competition in time trials and triathlons and are poorly suited for riding in cities or congested urban areas where conflicts with cars may require emergency braking.

PART II

ABOUT SHIMMY

Some cyclists have experienced disturbing “shimmy” or “vibration” at certain speeds. This symptom is rarely reported and there is no agreement among experts as to the cause. Among the proposed causes of shimmy are: a loose headset, frame alignment problems, weight of front wheel magnets for cycle computers, and spoke tension.

Larger riders on larger frames are thought by some to be more likely to experience such vibration.

If you experience such a vibration, gently apply the brakes and slow down. Another suggestion is to press your leg against the top tube as you slow down.

WARNING

IF YOU EXPERIENCE “SHIMMY,” DO NOT CONTINUE TO RIDE YOUR BIKE. TAKE THE BICYCLE TO REI FOR INSPECTION, SERVICE, OR CHANGES.

Whether or not you have overlap, or how much overlap you have can be changed. Be aware that toe clearance can be increased or decreased by changes in crankarm length, size of pedals or toe clips used, size of tires used, addition of fenders, size/design of shoes worn.

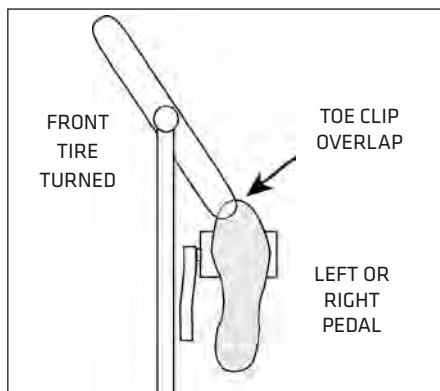

Figure 20.

WARNING

TOE CLIP OVERLAP COULD CAUSE YOU TO LOSE CONTROL OF YOUR BIKE, FALL AND BE SERIOUSLY INJURED, PARALYZED OR KILLED.

Please consult with REI to determine if your own combination of bicycle, shoe(s) and components have this common design feature.

SHIFTING GEARS WHILE PEDALING

CAUTION

Shifting under extreme pedaling pressure puts a great amount of stress on components. While most components can withstand an occasional “power shift,” continual power shifting will most assuredly damage some part of your drivetrain. Whenever possible, ease up on your pedals when shifting.

TIRE SIZE

WARNING

Mounting the wrong size tires can result in the tires hitting the fork or frame when riding. If this happens, you can lose control of your bike and you can be thrown off; a moving tire can be stopped because it touches the fork or frame.

Do not mount oversized tires, ones that rub or hit the fork or frame, ones that result in too little clearance, or ones that can hit the fork or frame when the suspension is fully compressed or when riding.

Take care that the tires you select are compatible with your bike’s fork or frame design. Also, be sure to follow the manufacturer’s recommendations of your front fork and rear shocks.

When you are considering tires for your bike consider:

The actual measured size of a tire may be different than its sidewall marking. Each time you mount a new tire, take the time to inspect the actual clearance between the rotating tire and all parts of the frame. The U.S. Consumer Product Safety Commission (CPSC) requires at least 1/16” (1.6 mm) tire clearance from any part of the bike. Allowing for lateral rim flex and a wheel or rim that is out-of-true will likely mean choosing a rear tire that provides even more clearance than the CPSC recommends.

ASK REI FOR THE RIGHT TIRES FOR YOUR BIKE AND ITS PARTICULAR COMPONENTS!

YOU CAN BE SEVERELY INJURED, PARALYZED OR KILLED IN AN ACCIDENT IF YOU IGNORE THIS WARNING.

TIRE & RIM PRESSURE COMPATIBILITY

WARNING

MAXIMUM TIRE PRESSURE MAY BE LIMITED BY RIM DESIGN.

1. ALWAYS check both tire sidewall and rim pressure markings. (If present)
2. NEVER inflate tire above maximum rim pressure. (If specified)

In the rapidly evolving area of disc brake specific lightweight and carbon fiber rims, some rim manufacturers have specified maximum tire pressure.

A customer might choose a tire with a maximum pressure listed on the sidewall that is higher than the maximum pressure listed on the rim. You must never exceed the maximum air pressure marked on the rim. (If present)

Excess pressure could lead to rim failure, and an accident, with risk of serious injury, paralysis or death. If you have any doubt or question, contact the rim manufacturer or insist that REI contact the rim manufacturer.

WARNING

Some Co-op bike models are equipped with tubeless-ready tires and/or rims, but all bikes come assembled with inner tubes. Tubeless valve stems and sealant must be used in conjunction with tubeless-ready tires and rims to hold air. Air loss can cause loss of control resulting in serious injury, paralysis or death. Use an inner tube or follow the instructions for tubeless-ready tire installation.

PART II

HOW TO CHECK WHEEL RIM WEAR

Check the condition of wheel rims wear before every ride.

It is important to your safety that you also check the surface wear of the wheel rims (in addition to brake pad wear). This is the area of the wheel where the brake pads contact the rim. Rims can wear out.

How Can You Check Rim Wear?

Some wheels have wear indicators built in. Some indicators are depressions in the rim lower than the surface where the pads touch. When the surface reaches this depression the wheel is worn out. Other indicators are visible markings or signs that are exposed to view when the braking surface is worn out.

Consult the wheel manufacturer's instructions/manuals for information on how to check wear for your specific wheels.

WARNING

Bicycle wheel rims are subject to wear and damage. A worn-out or damaged wheel rim has reached its maximum usable life and must be replaced.

Riding on unusable "worn-out" or damaged wheels can lead to braking or wheel failure.

Replace your wheel when they become worn-out or damaged.

Do not ride your bike when the wheels are damaged or worn-out.

Ask REI for help with inspecting the rim wear of your wheels.

You can be severely injured, paralyzed or killed in an accident if you ignore this message.

UNDERSTANDING DISC BRAKES ON ROAD BIKES

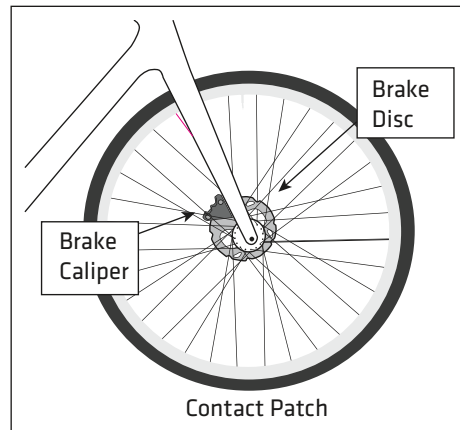

WARNING

Some road bikes are equipped with disc brakes. Relative to conventional rim brakes, disc brakes are less affected by water, do not wear or heat the rims and therefore are more consistent. Disc brakes also may be more powerful.

To minimize risk of injury or accidents:

Understand that road bikes have a relatively small tire contact patch (part of the tire that touches the road). In order to apply the brakes safely and effectively, you may need more or less braking force in different situations. You need to take into account various road and weather conditions that can affect traction.

Disc brakes are excellent, but not some kind of magic. Take some time riding your new disc brake road bike in lower risk circumstances to get used to the feel and performance of the disc brakes and tires.

You can be severely injured, paralyzed or killed in an accident if you ignore this message.

BRAKE POWER MODULATORS

Your bike may be equipped with a brake modulator, a device installed between the front brake lever and the front brake to reduce initial front braking force. (Brake power modulators are also used on the rear brake of some bicycles.)

If a rider applies the front brake too strongly or too suddenly, these devices can help reduce the risk of locking the front wheel or throwing the rider. Once the modulator device is bottomed out, the front brakes have the same power, and the same risks of overly hard use, as brakes without a modulator. Modulators are a small help in giving a rider more of a chance to react correctly.

Modulators are not a substitute for practicing and learning to brake correctly. See PART I, SECTION 4.C.

WARNING

A BRAKE MODULATOR WILL NOT PREVENT WHEEL LOCKUP OR BEING THROWN OFF THE BIKE DUE TO OVERLY HARD OR FAST OR ABRUPT APPLICATION OF THE BRAKES.

It is important that you understand modulators are not an intelligent, sophisticated system. Modulators ARE NOT anti-lock braking systems (ABS). Bicycle brake modulators are not like ABS in a car. Unlike automotive ABS there is not an intelligent system of sensors and computer control. Unlike an ABS system in a car, you cannot just jam on the brakes and let the system take over. There is no system to think or act for you.

We urge you to ask REI to confirm if you have a brake modulator on your bike. We urge you to ask REI to demonstrate how it works. We urge you to work with the front brake lever while standing still to understand how it works. We urge you to read any brake and brake modulator instructions that came with your bike.

AFTERMARKET BRAKE SYSTEMS

WARNING

DO NOT MODIFY YOUR BIKE IN ANY WAY TO MOUNT BRAKES SYSTEMS. MODIFICATIONS CAN DAMAGE YOUR BIKE LEADING TO AN ACCIDENT. YOU CAN BE SEVERELY INJURED OR KILLED.

Choose only brakes that mount to the frame, swingarm, or fork using only the existing disc brake, V-brake or cantilever mounts. Do not modify the existing mounts or clamp, weld, or in any other way add new or different mounts. Any modification will void the warranty and may weaken or damage the frame. For installation instructions and other warnings, read the literature provided by the brake manufacturer.

When choosing replacements, please ask REI. Have your bike's brakes installed and adjusted by a professional bike mechanic.

AFTERMARKET POWER SYSTEMS

WARNING

DO NOT INSTALL A POWER SYSTEM (GAS OR ELECTRIC TYPE) ONTO YOUR BIKE.

Your bike may not have been not designed or intended for use with any type of aftermarket power system.

There are many types of power systems from many different manufacturers. We simply can't predict what all can go wrong by installing one.

We can say that installing an aftermarket power system represents a MAJOR modification of your bike. It will change the way your bike handles and fundamentally alter its operation.

When combined with your bike, the power system can become dangerous to operate. For example, the brakes may not be adequate for higher speeds.

SECTION B. INTENDED USE

WARNING

UNDERSTAND YOUR BIKE AND ITS INTENDED USE. CHOOSING THE WRONG BICYCLE FOR YOUR PURPOSE CAN BE HAZARDOUS. USING YOUR BIKE THE WRONG WAY IS DANGEROUS.

No one type of bicycle is suited for all purposes. REI can help you pick the “right tool for the job” and help you understand its limitations. There are many types of bicycles and many variations within each type. We make many types of mountain, road, hybrid, and touring bicycles.

Within each type of bicycle, one can optimize for certain purposes. Visit REI and find someone with expertise in the area that interests you. Do your own homework. Seemingly small changes such as the choice of tires can improve or diminish the performance of a bicycle for a certain purpose.

Consult REI about how you intend to use your bike.

In addition to this section, please consult any Owner's Manual Supplements or components manufacturer's instructions for information on intended use.

INTENDED USE

Intended Use tables on the following pages contain information from Co-op Cycles and the ASTM International. All table information is part of the picture of intended use for your bike.

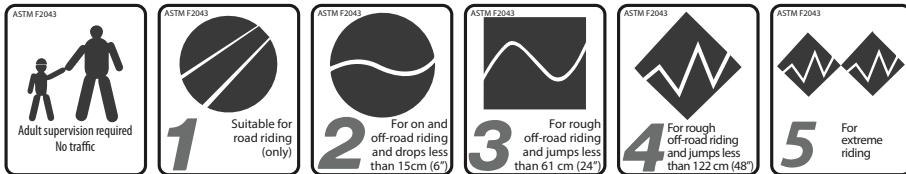

If you have any questions about intended use or the information presented in the tables, please ask REI.

For information on the F-2043-09 ASTM International standard, see <http://www.astm.org>.

CHILDREN'S

MODELS

All REV models



ASTM Condition 0

“This is a set of conditions for the operation of a bicycle designed for children over the age of 3 under appropriate parental supervision in a manner consistent with the child’s bicycling skills.”

MAXIMUM WEIGHT LIMIT FOR 12, 16 AND 20 INCH WHEELS

RIDER + GEAR = 80 lbs. (36 kg)

MAXIMUM WEIGHT LIMIT FOR 24 INCH WHEELS

RIDER + GEAR = 120 lbs. (54 kg)

HIGH-PERFORMANCE ROAD

MODELS (NOT APPLICABLE)

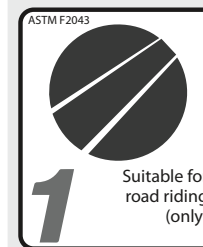

ASTM Condition 1

“This is a set of conditions for the operation of a bicycle on a regular paved or smooth surface where tires may unintentionally lose ground contact.”

PART II

GENERAL-PURPOSE RIDING

MODEL All ARD Models, All ADV Models, All CTY Models



ASTM Condition 2

"This is a set of conditions for the operation of a bicycle that includes Condition 1 as well as unpaved and gravel roads and trails with moderate grades. In this set of conditions, contact with irregular terrain and loss of tire contact with the ground may occur. Drops are intended to be limited to 15 cm (6 in.) or less."

MAXIMUM WEIGHT LIMIT

RIDER + GEAR = 300 lbs. (136 kg)

CROSS-COUNTRY, MARATHON, HARDTAILS

MODEL All Adult Hardtail DRT Models



ASTM Condition 3

"This is a set of conditions for operation of a bicycle that includes Condition 1 and Condition 2 as well as rough trails, rough unpaved roads and rough terrain and unimproved trails that require technical skills. Jumps and drops are intended to be less than 61 cm (24 in.)."

MAXIMUM WEIGHT LIMIT

RIDER + GEAR = 300 lbs. (136 kg)

PART II

ALL MOUNTAIN, OVERMOUNTAIN

MODELS

All Full Suspension DRT Models



ASTM Condition 4

"This is a set of conditions for operation of a bicycle that includes Conditions 1, 2 and 3, or downhill grades on rough trails at speeds less than 40 km/h (25 mph), or both. Jumps are intended to be less than 122 cm (48 in.)."

MAXIMUM WEIGHT LIMIT

RIDER + GEAR = 300 lbs. (136 kg)

GRAVITY, FREERIDE, DOWNHILL, DIRT JUMP

MODELS (NOT APPLICABLE)



CONDITION 5

"This is a set of conditions for operation of a bicycle that includes Conditions 1, 2, 3 and 4; extreme jumping; or downhill grades on rough trails at speeds in excess of 40 km/h (25 mph); or a combination thereof."

SECTION C. MOUNTAIN BIKE RIDING

See also APPENDIX A. Maximum Fork Length.

See also SECTION B. Intended Use.

OFF-ROAD RIDING

Off-road riding usually involves many, many variables such as constantly changing traction, obstacles, changes in line of sight, uphill, downhill, soft surfaces, dry surfaces, wet surfaces. Off-road riding requires managing a complex and constantly changing rider-to-bicycle feedback loop of traction, weight distribution, application of power, application of brakes and steering driven by the conditions one encounters. The complexity and ever-changing nature of off-road riding requires focus, concentration, strength, fitness and learning to read the trail. The art of managing all this while surrounded by nature makes this a challenging and wonderful sport.

WARNING

MOUNTAIN BIKE RIDING IS VERY DIFFERENT FROM RIDING A BIKE ON THE ROAD.

For starters, it is almost certain you will fall off.

Get training! Join a club and find experienced people to teach you. It is likely that REI can hook you up with local rides. Practice and learn to stay in control. Carefully, progressively, learn to expand your limits, but always ride within them.

BIKE TYPES

WARNING

PICK A MOUNTAIN BIKE FOR HOW YOU WILL RIDE.

There are many different kinds of “mountain bikes.” If you try using your bike for something it was not intended, you may break it with risk of serious injury, paralysis or death.

Matching the intended use of any kind of mountain bike to your expected riding is important.

Read PART II SECTION B. INTENDED USE.

INSPECTION AND MAINTENANCE ROUTINES

WARNING

MOUNTAIN BIKE RIDING IS VERY HARD ON BIKES.

MOUNTAIN BIKES NEED FREQUENT CLEANING, MAINTENANCE AND INSPECTION.

Clean your bike after every ride and conduct a pre-ride inspection before every ride. Detailed inspection as outlined in PART II SECTION D in this manual is needed more often than for road bikes. Failure to keep up with maintenance and inspection increases the risk of an accident, with risk of serious injury, paralysis or death.

SUSPENSION

Suspension will increase the handling capabilities and comfort of your bicycle. This enhanced capability may allow you to ride faster, particularly on rough or bumpy surfaces. As common sense tells you, increased speed brings increased risk.

WARNING

DO NOT CONFUSE THE BUILT-IN CAPABILITIES OF A SUSPENSION BIKE WITH YOUR OWN CAPABILITIES, WHICH MUST BE LEARNED.

Increasing your skill will take time and practice. Stay in control, and carefully, gradually learn the feel and handling of your suspension bike.

When you apply the front brakes on a suspension bike, the front of the bike will fall or dip as weight shifts forward. This is normal. (The front of your car dips when you apply the brakes.) You must learn to anticipate this weight shift and compensate by shifting your body weight back.

JUMPING

WARNING

JUMPING IS VERY RISKY. YOU COULD HAVE A FALL LEADING TO SERIOUS INJURY, PARALYSIS OR DEATH.

Jumping a mountain bike puts extreme stress on your bike. Perhaps most vulnerable to jumping-related damage is your fork. Riders who insist on jumping their bikes risk serious damage, to their bicycles as well as themselves.

STAY IN CONTROL

WARNING

FAILURE TO RIDE IN CONTROL COULD RESULT IN A FALL LEADING TO SERIOUS INJURY, PARALYSIS, OR DEATH.

While the risks inherent to this sport cannot be eliminated, you can minimize the risks by riding in control and wearing a helmet.

DOWNHILL AND LIFT-SERVICED RIDING

WARNING

TO RIDE DOWNHILL AT SPEED OR IN COMPETITION IS TO VOLUNTARILY ASSUME A VERY LARGE RISK. YOU COULD BE SERIOUSLY INJURED, PARALYZED, OR KILLED.

When riding downhill such as at a ski area, on trails or access roads, or on dirt roads such as fire roads, you can reach speeds seen on motorcycles, with similar hazards and risks.

Wear appropriate safety gear, including a full-face helmet, full-finger gloves, protective clothing, and body armor. Have your bicycle and equipment carefully inspected by a qualified mechanic and be sure it is in excellent condition. Consult with expert riders and/or race officials on conditions and equipment advisable at any site where you plan to ride downhill. Experienced riders often pre-walk or carefully and slowly pre-ride a downhill course before attempting it at any speed.

FREERIDING & DOWNHILL

 **WARNING****FREERIDING AND OTHER FORMS OF “EXTREME RIDING” ARE EXTREMELY DANGEROUS. YOU CAN BE SEVERELY INJURED OR KILLED IN A SERIOUS ACCIDENT.**

Freeriding, jumping, hucking, dirt jumping, mountaincross, downhill, slalom, slopestyle, urban or street riding or other evolving forms of extreme or hardcore mountain biking are inherently dangerous and can lead to serious accidents. Wear all safety gear and be sure your bike is in excellent condition. Follow all the instructions and warnings below. These steps will reduce, but not eliminate, the inherent risks. Even with state-of-the-art protective safety gear, you could be seriously injured, paralyzed or killed. If you do not want to take these risks, do not engage in this type of riding.

Fundamental Risk

What videos and bike magazines and ads don't always tell you is that extreme riding takes an amazing amount of skill. Some of the riders you see are well-paid pros who have gradually built up their skills through endless hours of practice, and who have also had their share of stitches, concussions and busted bones (and bikes). Others are daredevils who have chosen to accept or ignore the risks. Do not copy those you see in the media without thought of the serious risks.

The stakes are high if you make a mistake. Realize too late that you aren't up to the challenge, and you run the risk of major injury, paralysis, or even death. In short, extreme riding carries a high degree of fundamental risk, and you bear the ultimate responsibility for how you ride and what you attempt to pull off. Do you want to avoid these significant risks? Then do not ride this way.

Product Limitations

Problems of rider error aside, hardcore riding is hard on your equipment. Although we build and test our bikes to make them tough, there's no way that we can guarantee they'll survive the abuse of “extreme riding.” For starters, there is no industry “jumping” standard. The many circumstances of takeoff, landing, speed, rider technique, etc. are unique. The judgment, or lack of judgment of a rider who may ride a bicycle cannot be completely predicted, so it's flat-out impossible to predict how anyone's equipment is going to hold up.

(continued on next page...)

(continued from previous page...)

Do not confuse the built-in capabilities of equipment with your own capabilities, which must be learned.

Keeping your bike and all its components in good working order is critical, and it's up to you to maintain and inspect it. Even so, your bicycle isn't going to last forever. Nothing does, particularly bikes and parts that are built to minimize weight and then are subjected to abuse. Co-op Cycles frames carry a warranty, but that's to cover issues with workmanship and/or materials. (See the Limited Warranty in this manual). The warranty doesn't mean that they're going to last forever. They're not. The warranty certainly doesn't mean that the bicycle can in any way protect you from injury.

Use of Specialized Protective Gear

Co-op Cycles has long urged the use of helmets. We have recently become aware of neck braces, designed for mountain biking and motocross riding, fitted between the rider and helmet, that can decrease the risk of paralysis, spinal cord and neck injuries. As the manufacturer clearly states, these braces cannot prevent all injuries. We urge riders, particularly riders into challenging and risky riding, to investigate and consider prophylactic neck braces.

In Conclusion

If you plan on doing any “extreme riding,” be smart about it. Always wear a full-face helmet, state-of-the-art neck brace, body armor, full-finger gloves, and protective clothing. Choose a bike that's right for you, your riding and terrain, and check it often for signs of fatigue or other trouble. (REI can help you on both fronts.) Read PART II, SECTION B. MOUNTAIN BIKE RIDING. And most importantly, know your limitations. Practice. Stay in control, and carefully, gradually expand your limits—but ride within them.

YOU CAN BE SEVERELY INJURED, PARALYZED, OR KILLED IF YOU IGNORE THIS WARNING.

SECTION D. INSPECT FOR SAFETY

In this section, we will do our best to outline some material science basics and explain how they relate to your bicycle, some of the tradeoffs made in designing your bicycle, what you can expect from your bicycle and provide important, basic guidelines on how you maintain and inspect it.

WARNING

FREQUENT INSPECTION OF YOUR BIKE IS IMPORTANT TO YOUR SAFETY. FOLLOW THE PRE-RIDE CHECKLIST BEFORE EVERY RIDE.

See the back cover of this manual.

Periodic, more detailed inspection of your bicycle is important. How often this more detailed inspection is needed depends upon you.

You, the rider/owner, have control and knowledge of how often you use your bike, how hard you use it and where you use it. Co-op Cycles does not. We design rugged and light bicycles and test them extensively. But, because we cannot track your use, you must be responsible for inspection and maintenance. Most customers will have a local REI do all inspection and maintenance.

If you are not interested in the “hands on” aspects of your bicycle, and do not wish to perform inspection or maintenance on your own bike, then you must make REI or a partner in maintaining and inspecting your bicycle. Work with REI to determine a maintenance and inspection schedule appropriate for your riding. PART I, SECTION 5. A provides some general guidelines on service intervals.

For your safety, understanding and communication with REI, we urge you to read this section. The materials used to make your bike determine how to inspect it properly.

YOU CAN BE SEVERELY INJURED, PARALYZED, OR KILLED IF YOU IGNORE THIS WARNING.

THE LIFESPAN OF YOUR BIKE AND ITS COMPONENTS

1. Nothing Lasts Forever, Including Your Bike.

When the useful life of your bike or its components is over, continued use is hazardous.

Every bicycle and its component parts have a finite, limited useful life. The length of that life will vary with the construction and materials used in the frame and components; the maintenance and care the frame and components receive over their life; and the type and amount of use to which the frame and components are subjected. Use in competitive events, trick riding, ramp riding, jumping, aggressive riding, riding on severe terrain, riding in severe climates, riding with heavy loads, commercial activities and other types of non-standard use can dramatically shorten the life of the frame and components. Any one or a combination of these conditions may result in an unpredictable failure.

All aspects of use being identical, lightweight bicycles and their components will usually have a shorter life than heavier bicycles and their components. In selecting a lightweight bicycle or components you are making a tradeoff, favoring the higher performance that comes with lighter weight over longevity. So, If you choose lightweight, high performance equipment, be sure to have it inspected frequently.

You should have your bicycle and its components checked periodically by your dealer for indicators of stress and/or potential failure, including cracks, deformation, corrosion, paint peeling, dents, and any other indicators of potential problems, inappropriate use or abuse. These are important safety checks and very important to help prevent accidents, bodily injury to the rider and shortened product life.

2. Perspective

Today's high-performance bicycles require frequent and careful inspection and service. In this Appendix we try to explain some underlying material science basics and how they relate to your bicycle. We discuss some of the trade-offs made in designing your bicycle and what you can expect from your bicycle; and we provide important, basic guidelines on how to maintain and inspect it. We cannot teach you everything you need to know to properly

inspect and service your bicycle; and that is why we repeatedly urge you to take your bicycle to your dealer for professional care and attention.

WARNING

Frequent inspection of your bike is important to your safety. Follow the Mechanical Safety Check in Section 1.C of this Manual before every ride.

Periodic, more detailed inspection of your bicycle is important. How often this more detailed inspection is needed depends upon you.

You, the rider/owner, have control and knowledge of how often you use your bike, how hard you use it and where you use it. Because your dealer cannot track your use, you must take responsibility for periodically bringing your bike to your dealer for inspection and service. Your dealer will help you decide what frequency of inspection and service is appropriate for how and where you use your bike.

For your safety, understanding and communication with your dealer, we urge you to read this Appendix in its entirety. The materials used to make your bike determine how and how frequently to inspect.

Ignoring this WARNING can lead to frame, fork or other component failure, which can result in serious injury or death.

A. UNDERSTANDING METALS

Steel is the traditional material for building bicycle frames. It has good characteristics, but in high performance bicycles, steel has been largely replaced by aluminum and some titanium. The main factor driving this change is interest in lighter bicycles by cycling enthusiasts.

Properties of Metals

Please understand that there is no simple statement that can be made that characterizes the use of different metals for bicycles. What is true is how the metal chosen is applied is much more important than the material alone. One must look at the way the bike is designed, tested, manufactured, supported along with the characteristics of the metal rather than seeking a simplistic answer.

Metals vary widely in their resistance to corrosion. Steel must be protected or rust will attack it. Aluminum and Titanium quickly develop an oxide film that protects the metal from further corrosion. Both are therefore quite resistant to corrosion. Aluminum is not perfectly corrosion resistant, and particular care must be used where it contacts other metals and galvanic corrosion can occur.

Metals are comparatively ductile. Ductile means bending, buckling and stretching before breaking. Generally speaking, of the common bicycle frame building materials steel is the most ductile, titanium less ductile, followed by aluminum.

Metals vary in density. Density is weight per unit of material. Steel weighs 7.8 grams/cm³ (grams per cubic centimeter), titanium 4.5 grams/cm³, aluminum 2.75 grams/cm³. Contrast these numbers with carbon fiber composite at 1.45 grams/cm³.

Metals are subject to fatigue. With enough cycles of use, at high enough loads, metals will eventually develop cracks that lead to failure. It is very important that you read the basics of metal fatigue below.

Let's say you hit a curb, ditch, rock, car, another cyclist or other object. At any speed above a fast walk, your body will continue to move forward, momentum carrying you over the front of the bike. You cannot and will not stay on the bike, and what happens to the frame, fork and other components is irrelevant to what happens to your body.

What should you expect from your metal frame? It depends on many complex factors, which is why we tell you that crashworthiness cannot be a design criteria. With that important note, we can tell you that if the impact is hard enough the fork or frame may be bent or buckled. On a steel bike, the steel fork may be severely bent and the frame undamaged. Aluminum is less ductile than steel, but you can expect the fork and frame to be bent or buckled. Hit harder and the top tube may be broken in tension and the down tube buckled. Hit harder and the top tube may be broken, the down tube buckled and broken, leaving the head tube and fork separated from the main triangle.

When a metal bike crashes, you will usually see some evidence of this ductility in bent, buckled or folded metal.

It is now common for the main frame to be made of metal and the fork of carbon fiber. See Section B, Understanding composites below. The relative

ductility of metals and the lack of ductility of carbon fiber means that in a crash scenario you can expect some bending or buckling in the metal but none in the carbon. Below some load the carbon fork may be intact even though the frame is damaged. Above some load the carbon fork will be completely broken.

The basics of metal fatigue

Common sense tells us that nothing that is used lasts forever. The more you use something, and the harder you use it, and the worse the conditions you use it in, the shorter its life.

Fatigue is the term used to describe accumulated damage to a part caused by repeated loading. To cause fatigue damage, the load the part receives must be great enough. A crude, often-used example is bending a paper clip back and forth (repeated loading) until it breaks. This simple definition will help you understand that fatigue has nothing to do with time or age. A bicycle in a garage does not fatigue. Fatigue happens only through use.

So what kind of "damage" are we talking about? On a microscopic level, a crack forms in a highly stressed area. As the load is repeatedly applied, the crack grows. At some point the crack becomes visible to the naked eye. Eventually it becomes so large that the part is too weak to carry the load that it could carry without the crack. At that point there can be a complete and immediate failure of the part.

One can design a part that is so strong that fatigue life is nearly infinite. This requires a lot of material and a lot of weight. Any structure that must be light and strong will have a finite fatigue life. Aircraft, race cars, motorcycles all have parts with finite fatigue lives. If you wanted a bicycle with an infinite fatigue life, it would weigh far more than any bicycle sold today. So we all make a tradeoff: the wonderful, lightweight performance we want requires that we inspect the structure.

What to look for

<ul style="list-style-type: none"> • ONCE A CRACKS STARTS IT CAN GROW AND GROW FAST. Think about the crack as forming a pathway to failure. This means that any crack is potentially dangerous and will only become more dangerous. 	<p>SIMPLE RULE 1 : If you find crack, replace the part.</p>
<ul style="list-style-type: none"> • CORROSION SPEEDS DAMAGE. Cracks grow more quickly when they are in a corrosive environment. Think about the corrosive solution as further weakening and extending the crack. 	<p>SIMPLE RULE 2 : Clean your bike, lubricate your bike, protect your bike from salt, remove any salt as soon as you can.</p>
<ul style="list-style-type: none"> • STAINS AND DISCOLORATION CAN OCCUR NEAR A CRACK. Such staining may be a warning sign that a crack exists. 	<p>SIMPLE RULE 3 : Inspect and investigate any staining to see if it is associated with a crack.</p>
<ul style="list-style-type: none"> • SIGNIFICANT SCRATCHES, GOUGES, DENTS OR SCORING CREATE STARTING POINTS FOR CRACKS. Think about the cut surface as a focal point for stress (in fact engineers call such areas "stress risers," areas where the stress is increased). Perhaps you have seen glass cut? Recall how the glass was scored and then broke on the scored line. 	<p>SIMPLE RULE 4 : Do not scratch, gouge or score any surface. If you do, pay frequent attention to this area or replace the part.</p>
<ul style="list-style-type: none"> • SOME CRACKS (particularly larger ones) MAY MAKE CREAKING NOISE AS YOU RIDE. Think about such a noise as a serious warning signal. Note that a well-maintained bicycle will be very quiet and free of creaks and squeaks. 	<p>SIMPLE RULE 5 : Investigate and find the source of any noise. It may not a be a crack, but whatever is causing the noise should be fixed promptly.</p>

Fatigue Is Not A Perfectly Predictable Science

Fatigue is not a perfectly predictable science, but here are some general factors to help you and your dealer determine how often your bicycle should be inspected. The more you fit the “shorten product life” profile, the more frequent your need to inspect. The more you fit the “lengthen product life” profile, the less frequent your need to inspect.

Factors that shorten product life:

- Hard, harsh riding style
- “Hits”, crashes, jumps, other “shots” to the bike
- High mileage
- Higher body weight
- Stronger, more fit, more aggressive rider
- Corrosive environment (wet, salt air, winter road salt, accumulated sweat)
- Presence of abrasive mud, dirt, sand, soil in riding environment

Factors that lengthen product life:

- Smooth, fluid riding style
- No “hits”, crashes, jumps, other “shots” to the bike
- Low mileage
- Lower body weight
- Less aggressive rider
- Non-corrosive environment (dry, salt-free air)
- Clean riding environment

WARNING

Do not ride a bicycle or component with any crack, bulge or dent, even a small one. Riding a cracked frame, fork or component could lead to complete failure, with risk of serious injury or death.

B. UNDERSTANDING COMPOSITES

All riders must understand a fundamental reality of composites. Composite materials constructed of carbon fibers are strong and light, but when crashed or overloaded, carbon fibers do not bend, they break.

What Are Composites?

The term “composites” refers to the fact that a part or parts are made up of different components or materials. You’ve heard the term “carbon fiber bike.” This really means “composite bike.”

Carbon fiber composites are typically a strong, light fiber in a matrix of plastic, molded to form a shape. Carbon composites are light relative to metals. Steel weighs 7.8 grams/cm³ (grams per cubic centimeter), titanium 4.5 grams/cm³, aluminum 2.75 grams/cm³. Contrast these numbers with carbon fiber composite at 1.45 grams/cm³.

The composites with the best strength-to-weight ratios are made of carbon fiber in a matrix of epoxy plastic. The epoxy matrix bonds the carbon fibers together, transfers load to other fibers, and provides a smooth outer surface. The carbon fibers are the “skeleton” that carries the load.

Why Are Composites Used?

Unlike metals, which have uniform properties in all directions (engineers call this isotropic), carbon fibers can be placed in specific orientations to optimize the structure for particular loads. The choice of where to place the carbon fibers gives engineers a powerful tool to create strong, light bicycles. Engineers may also orient fibers to suit other goals such as comfort and vibration damping.

Carbon fiber composites are very corrosion resistant, much more so than most metals. Think about carbon fiber or fiberglass boats.

Carbon fiber materials have a very high strength-to-weight ratio.

What Are The Limits Of Composites?

Well designed “composite” or carbon fiber bicycles and components have long fatigue lives, usually better than their metal equivalents.

While fatigue life is an advantage of carbon fiber, you must still regularly inspect your carbon fiber frame, fork, or components.

Carbon fiber composites are not ductile. Once a carbon structure is overloaded, it will not bend; it will break. At and near the break, there will be rough, sharp edges and maybe delamination of carbon fiber or carbon fiber fabric layers. There will be no bending, buckling, or stretching.

If You Hit Something Or Have A Crash, What Can You Expect From Your Carbon Fiber Bike?

Let’s say you hit a curb, ditch, rock, car, other cyclist or other object. At any speed above a fast walk, your body will continue to move forward, the momentum carrying you over the front of the bike. You cannot and will not stay on the bike and what happens to the frame, fork and other components is irrelevant to what happens to your body.

What should you expect from your carbon frame? It depends on many complex factors. But we can tell you that if the impact is hard enough, the fork or frame may be completely broken. Note the significant difference in behavior between carbon and metal. See Section 2. A, Understanding metals in this Appendix. Even if the carbon frame was twice as strong as a metal frame, once the carbon frame is overloaded it will not bend, it will break completely.

WARNING

Be aware that high temperature in a confined environment can affect the integrity of composite materials, resulting in component failure which could cause you to lose control and fall.

INSPECTION OF COMPOSITE FRAME, FORK, AND COMPONENTS

Cracks:

Inspect for cracks, broken, or splintered areas. Any crack is serious. Do not ride any bicycle or component that has a crack of any size.

Delamination:

Delamination is serious damage. Composites are made from layers of fabric. Delamination means that the layers of fabric are no longer bonded together. Do not ride any bicycle or component that has any delamination. These are some delamination clues:

1. A cloudy or white area. This kind of area looks different from the ordinary undamaged areas. Undamaged areas will look glassy, shiny, or “deep,” as if one was looking into a clear liquid. Delaminated areas will look opaque and cloudy.
2. Bulging or deformed shape. If delamination occurs, the surface shape may change. The surface may have a bump, a bulge, soft spot, or not be smooth and fair.
3. A difference in sound when tapping the surface. If you gently tap the surface of an undamaged composite you will hear a consistent sound, usually a hard, sharp sound. If you then tap a delaminated area, you will hear a different sound, usually duller, less sharp.

Unusual Noises:

Either a crack or delamination can cause creaking noises while riding. Think about such a noise as a serious warning signal. A well maintained bicycle will be very quiet and free of creaks and squeaks. Investigate and find the source of any noise. It may not be a crack or delamination, but whatever is causing the noise must be fixed or replaced before riding.

WARNING

Do not ride a bicycle or component with any delamination or crack. Riding a delaminated or cracked frame, fork or other component could lead to complete failure, with risk of serious injury or death.

PART II

C. UNDERSTANDING COMPONENTS

It is often necessary to remove and disassemble components in order to properly and carefully inspect them. This is a job for a professional bicycle mechanic with the special tools, skills and experience to inspect and service today's high-tech high-performance bicycles and their components.

Aftermarket "Super Light" components

Think carefully about your rider profile as outlined above. The more you fit the "shorten product life" profile, the more you must question the use of super light components. The more you fit the "lengthen product life" profile, the more likely it is that lighter components may be suitable for you. Discuss your needs and your profile very honestly with your dealer.

Take these choices seriously and understand that you are responsible for the changes.

A useful slogan to discuss with your dealer if you contemplate changing components is "Strong, Light, Cheap -pick two."

Original Equipment components

Bicycle and component manufacturers test the fatigue life of the components that are original equipment on your bike. This means that they have met test criteria and have reasonable fatigue life. It does not mean that the original components will last forever. They won't.

SECTION E. MAINTENANCE

WARNING

INSPECTION AND MAINTENANCE ARE IMPORTANT TO YOUR SAFETY AND THE LONGEVITY OF YOUR BICYCLE.

Any part of a poorly maintained bike can break or malfunction leading to an accident where you can be killed, severely injured or paralyzed.

Please ask REI to help you develop a complete maintenance program, a program which includes a list of the parts on your bike for YOU to check regularly. Frequent checks are necessary to identify the problems that can lead to an accident.

YOU CAN BE SEVERELY INJURED, PARALYZED OR KILLED IN AN ACCIDENT IF YOU IGNORE THIS WARNING.

E.1 - WARRANTY TUNE

REI tries to minimize the "break-in" effect of a new bicycle by precisely adjusting it with this initial period in mind. However, the bicycle will need mechanical attention during the first ten (10) to fifteen (15) hours of use to return it to an optimum performance level.

In essence, a "Warranty Tune" brings a recently purchased bicycle back to the state it was in when it left the store for the first time. This "Warranty Tune" is a free service that REI provides to our customers, ensuring a positive ongoing experience.

As a general rule of thumb, two months of moderate riding in good conditions, 2-3 times weekly, will be sufficient to break in a bicycle. If you experience any problems sooner, you should bring the bicycle in for service immediately.

CLEANING

There are many cleaning supplies made specifically for bicycles, but you can also use water and mild dishwashing liquid.

On suspension forks and shocks, cover adjustment knobs and air filter (if equipped) with a clean plastic bag secured temporarily with a rubber band or masking tape.

Before wiping away dirt, use an ordinary water hose to gently spray off heavy soils and dirt.

CAUTION

DO NOT POWER WASH or spray water under high pressure to clean. Power washing will force contaminants into parts where they will promote corrosion, immediately damage, or result in accelerated wear.

DO NOT USE COMPRESSED AIR TO DRY.

DO NOT USE ABRASIVE OR HARSH CHEMICAL CLEANER/SOLVENTS which can damage the finish or attack and destroy both the outside and internal parts.

When rinsing, avoid directing the spray directly at shock/fork adjusters or bearings.

PREVENTING CORROSION

After cleaning and drying, it is a good idea to lightly coat the water bottle bosses with a water-displacing lubricant such as Tri-Flow to minimize corrosion from sweat and salt. This is particularly important on bicycles used in coastal salt air environments and those drenched in sweat on an indoor trainer.

To thoroughly clean the frame, it is desirable to remove components. This is best done in conjunction with a periodic overhaul by an REI bike shop.

PART II

LUBRICATION

After cleaning your bike, you should lubricate it. The chain should be lubricated. Consult with REI or local bike shop to choose among the many types of chain lubes best suited to your climate and riding conditions. The pivot points on your derailleurs should be lubricated. Apply a small drop of oil to each pivot point and wipe off the excess.

Periodically, depending upon how, how often, and where you ride and the design of the components on your bike, other lubrication must be part of your maintenance. Some of you will know how to perform the procedures on this checklist, while others will need to take the bike to a local REI. If you are not an experienced and skilled bicycle mechanic, take your bike to REI.

Other Lubrication Checklist

• Derailleur cables
• Brake cables
• Brake pivots
• Headset bearings
• Bottom bracket bearings
• Hub bearings
• Freehub
• Seatpost to seat tube, see page 75.
• Stem to steering tube

FASTENER TORQUE SPECIFICATIONS

Correct tightening torque of threaded fasteners is very important to your safety. Always tighten fasteners to the correct torque. In case of a conflict between the instructions in this manual and information provided by a component manufacturer, consult with your dealer or the manufacturer's customer service representative for clarification. Bolts that are too tight can stretch and deform. Bolts that are too loose can move and fatigue. Either mistake can lead to a sudden failure of the bolt.

Always use a correctly calibrated torque wrench to tighten critical fasteners on your bike. Carefully follow the torque wrench manufacturer's instructions on the correct way to set and use the torque wrench for accurate results.

FASTENER RECOMMENDED TORQUE

WHEELS
PEDALS
SEAT POST CLAMP
SADDLE CLAMP
STEERER CLAMP
HANDLEBAR CLAMP
CONTROL LEVER CLAMPS

Find Tightening Torque Information for Your Bike

The wide range of bicycle models and components used means that a listing of tightening torque would be out of date by the time it was published. Many fasteners should be installed with a thread-locking adhesive such as Loctite®.

To determine correct tightening torque and any adhesive application for a fastener, we ask you to check:

Markings on the component. Many components are marked. On-product marking is becoming common.

Torque specs in the component manufacturers instructions shipped with your bicycle.

Torque specs listed on the websites of component manufacturers.

With REI. REI has access to current data and have experience with correct torque for most fasteners.

BICYCLE REPAIR / WORK STANDS

The clamping jaws of a bike stand can generate a crushing force strong enough to seriously damage your frame. See next figure.

CAUTION

Never place your bike in a bike stand by clamping the frame.

Place your bike in a stand by extending the seatpost and positioning the stand clamp on the extended seatpost. Don't extend beyond the MINIMUM INSERT line marked on the seatpost.

Since your carbon seatpost can also be damaged by clamping force, adjust the stand clamp for the minimum clamping force needed to secure the bike.

Also, before clamping, clean the post and protect the seatpost finish with a rag.

RIDING THROUGH WATER

CAUTION

"Sealed" components (such as headsets, bottom brackets and hubs) are effective at keeping mud and grit out of your bearings.

However, any bike that is submerged or exposed to large amounts of water will require a complete bearing overhaul to prevent extensive—and expensive—damage.

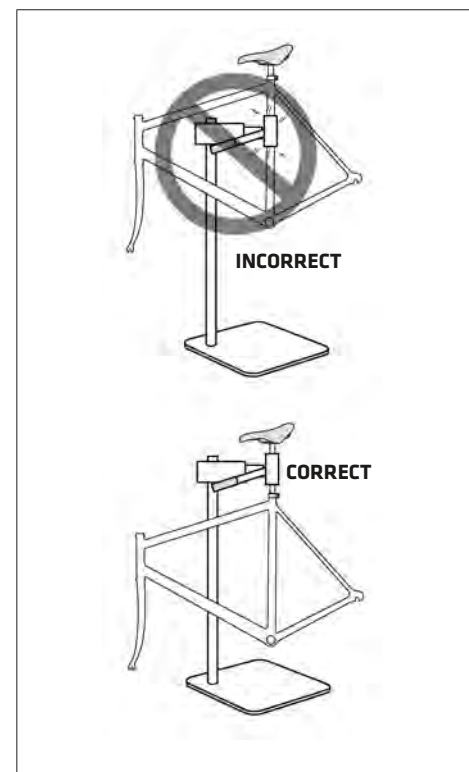

Figure 22.

Protect Carbon Bikes From Extreme Temperatures

- Protect your carbon bike from extreme temperatures when storing or transporting it.
- Allow your bike to cool off or warm up before you ride.
- Do not store your bike in places where the temperature will exceed 66.5°C (150°F).

For example, do not leave your bike lying flat in a black pickup truck bed in the desert sun, or, under the glass of a hatchback auto.

PART II

FRAME PROTECTION

Some areas of your bicycle may require protection from abrasion. Your bicycle comes equipped with recommended frame protection. Additional guard material can be added at the rider's discretion. If the required protection is removed or worn, damage can result.

NOTE: Damage to your bike caused by cable housing rubbing or the chain contacting the chainstay are not conditions covered under warranty. Make sure the necessary guard material is in place.

CAUTION

Over time, cable housing rubbing and chain contacting the chainstay can wear into the frame itself causing very serious frame damage. Inspect your bike before each ride and replace worn frame protection or apply additional guard material if rubbing is found.

To apply the guard material:

1. Clean the frame with a mild detergent and wipe dry with a clean towel. Do not use solvents or harsh chemicals to clean the frame. **OPTIONAL:** Trim the adhesive guard material to the shape required.
2. Remove the backing and position the guard under the cable/ line.
3. Rub the guard firmly against the frame with your fingers to fix it in place.
4. Periodically, recheck the guards and other areas of the frame as you continue to ride. Replace the guards if they wear out.

Also, adhesive frame guards are not a fix for incorrectly installed or routed cables or lines. If you find that applied guards are wearing out very quickly, consult with REI about the routing on your bike.

WATER BOTTLES

Side impacts to a water bottle or cage can result in damaged threaded inserts due to the leverage on a very small area. In a crash, certainly the last thing you should be worried about is saving the threaded inserts in your frame. However, when you are storing or transporting your bike, take steps to prevent situations where a water bottle may be hit or bumped by a strong force that would cause damage. Remove bottle and cage when you are packing your bike for travel.

Periodically check the attachment of the bottle cage; tighten the cage bolts if necessary. Don't ride with a loose bottle cage. Riding with loose cage bolts can produce a rocking motion or vibration of the attached cage. A loose cage will damage the insert and possibly lead to the inserts pulling out. It may be possible to repair a loose insert, or install another insert only if the frame is undamaged. Replacement requires the use of a special tool. If you notice damage to the threaded insert, please ask REI for help.

CAUTION

WATER BOTTLES—An impact, crash, or loose bottle cage can result in damage to your frame.

This kind of damage is not covered by the REI Limited Warranty.

PART II

E.7 - SERIAL NUMBER

The serial number for your bike is located on the underside of the bottom bracket. See fig. 20.

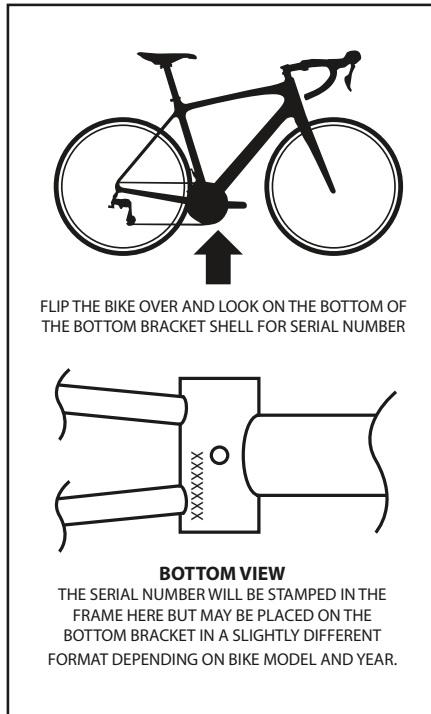

Figure 20. Underside of Bottom Bracket

Where Else Can I Find the Serial Number?

The serial number should also appear on your original purchase documents.

SECTION F. REI LIMITED WARRANTY

100% SATISFACTION GUARANTEE AND LIMITED WARRANTY

We stand behind everything we sell. If you are not satisfied with your REI purchase, you can return it for a replacement or refund within one year of purchase. REI's guarantee doesn't cover ordinary wear and tear or damage caused by improper use or accidents. If your item has a manufacturing defect in its materials or workmanship, you can return it at any time. This limited warranty gives you specific legal rights, and you may have other rights which vary from state to state.

SECTION G. PRE-RIDE CHECKLIST

WARNING

FOLLOW THIS CHECKLIST BEFORE EVERY RIDE. IF YOU HAVE ANY REASON TO SUSPECT THAT YOUR BICYCLE IS NOT FUNCTIONING PROPERLY, DO NOT RIDE IT.

Have it inspected by an REI bike shop. Failure to follow this checklist and to have any potential problem inspected could lead to an accident, with risk of serious injury, paralysis or death.

Are you wearing a helmet and other appropriate equipment and clothing, such as protective glasses and gloves? Do not wear loose clothing that could become entangled in the bicycle (See PART I, Section 2.A The Basics).

Are your seatpost and stem securely fastened? Twist the handlebar firmly from side to side while holding the front wheel between your knees. The stem must not move in the steering tube. Similarly, the seatpost must be secure in the seat tube (See PART I, Section 3. Fit).

Are you visible to motorists? If you are riding at dusk, dawn or at night, you must make yourself visible to motorists. Use front and rear lights and a strobe or blinker. Reflectors alone do not always provide adequate visibility. Wear reflective clothing (See PART I, Section 2.E Night Riding and PART II, A. Important Safety Information).

Is it raining or wet? If so, be more cautious. Your braking distances will increase, and your tires' grip on the road will decrease. Remember that motorists' visibility decreases with bad weather (See PART I, Section 2.D Wet Weather Riding and PART II, A. Important Safety Information).

Are your tires properly inflated? Tires must be inflated to the recommended pressure. (See PART I, Section 4.G Tires and Tubes).

Are your wheels true? Lift each end of the bike and spin each wheel. Does the space between the rim and the brake pads, or the tire and the frame, remain nearly the same size as the wheel turns? Are your spokes tight? (See PART I, Section 1.C Mechanical Safety Check).

Are your wheels' quick-releases properly fastened? Be sure to read the section on proper operation of quick-release skewers (See PART I, Section 4.A Wheels).

Are your front and rear brakes functioning properly? With V-brakes, the quick-release "noodle" must be properly installed. With cantilever brakes, the quick-release straddle cable must be properly attached. With caliper brakes the quick-release lever must be closed. With any rim brake, the brake pads must make firm contact with the rim without the brake levers hitting the handlebar grip (See PART I, Section 4.C Brakes).

With hydraulic disc brakes, check that the lever feels firm, does not move too close to the handlebar grip, and there is no evidence of leaking brake fluid. With cable actuated disc brakes, check that the lever feels firm and does not move too close to the handlebar grip. With any disc brakes, the brake pads must make firm contact with the rotor without the brake levers hitting the handlebar grip (See PART I, Section 4.C Brakes).

How do your clipless pedals work today? Clip in and out of your pedals before you begin. Experienced cyclists do. The connection between cleat and pedal is affected by dozens of factors including dirt, mud, lubrication, spring tension and wear. By clipping in and out you will check the function and have a fresh memory of how they feel (See PART I, Section 4.E Pedals).

How recently were your frame, fork and components inspected? Never ride a frame, fork or components with any crack or damage. (See PART II, - Section D. Inspect For Safety)

APPENDIX A.

MAXIMUM FORK LENGTH (Mountain Bikes)

Maximum Fork Length is an important frame safety testing specification for front suspension mountain bikes. You must observe the measurement when installing headset parts, headset adapters, installing and adjusting a fork, and selecting replacement forks.

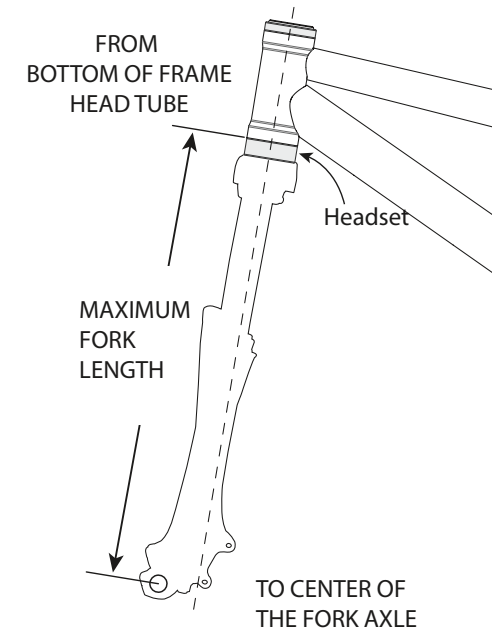

WARNING

YOU MUST SELECT A REPLACEMENT FORK NOT ONLY BASED ON HEAD TUBE DIAMETER BUT THE CRITICAL FACTOR OF FRAME MAXIMUM FORK LENGTH.

DO NOT EXCEED MAXIMUM FORK LENGTH. Exceeding the MAXIMUM FORK LENGTH limit can overload the frame causing it to break while riding. The maximum fork length is the OEM length.

YOU CAN BE SEVERELY INJURED, PARALYZED OR KILLED IN AN ACCIDENT IF YOU IGNORE THIS WARNING.

APPENDIX B.

CARE AND MAINTENANCE OF
CARBON FIBER SEATPOSTS

Inserting the Seatpost

Check the seat tube (1) opening and slot (2) carefully for sharp edges or burrs. Anything that can scratch, score, gouge, or cut the seatpost can cause serious damage leading to breakage of the seatpost. Sharp edges or burrs can be removed by hand by lightly sanding with a very fine sandpaper (400 grit). The should feel very smooth without jagged edges or nicks.

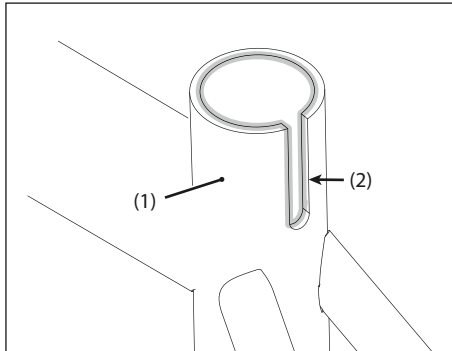

Figure 32.

1. Make sure the seatpost, seat binder, and seat tube are clean.
2. Apply small amount of a carbon seatpost gel to seatpost surface. The gel adds desirable friction and minimizes corrosion. It will help keep your seatpost in place.

3. Position the seat binder on the seat tube with the binder slot (A) opposite the seat tube slot (B). Locating the binder slot opposite the seat tube slot reduces the chances of cracking from deformation or accidental overtightening.
4. Insert the seatpost and tighten the seat binder to the specified torque with an accurate torque wrench. Consult the seatpost manufacturer's instructions for torque information.
5. Check tightening torques of the saddle to seatpost clamp bolts. Too much torque may break the bolts. Too little torque will result in movement which leads to fatigue and bolt breakage.

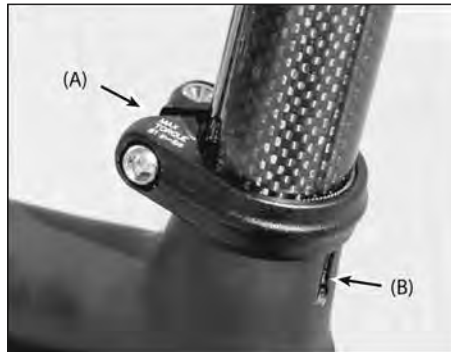

Figure 33.

Periodic Seatpost Inspection

Frequent seatpost checks are necessary to identify the problems that can lead to an accident. Regularly or in conjunction with your regular bike maintenance routine, do the following:

1. Remove the seat binder from the frame seatpost. Clean the binder, the seatpost, and inside the seat tube. Use a clean dry towel. Do not use solvents.
2. Carefully inspect the seatpost for damage (e.g., cracks, scratches, scrapes, gouges, splintering). If the seatpost is damaged in any way, (cracks, scratches, scrapes, gouges, splintering), do not ride it; discard it. Replace it with a new one.
3. Always properly torque saddle to seatpost clamp bolts. Too much torque may break the bolts. Too little torque will result in movement which leads to fatigue and bolt breakage.

 **WARNING**

To avoid seatpost or frame damage:

1. **FOLLOW THE SEATPOST MANUFACTURER'S INSTRUCTIONS.** If you do not have the manufacturer's instructions for your seatpost, obtain and read them before using the seatpost.
2. **INSPECT AFTER ANY CRASH, FALL, OR IMPACT.** Remove and inspect the seatpost for damage (eg., cracks, scratches, scrapes, gouges, splintering). If you find damage, replace it with a new one. STOP RIDING A DAMAGED SEATPOST IMMEDIATELY. GO TO PART II, SECTION D. Inspect For Safety. Read "Understanding Composites" for information on carbon fiber
3. **NEVER FORCE A SEATPOST INTO THE SEAT TUBE.** The seatpost should always be a slide fit. If the seatpost is difficult to install, there is a serious problem. Do not shorten or cut a seatpost. Ask REI for help in properly fitting and adjusting your seatpost.

4. KEEP THE SEATPOST'S "MINIMUM INSERT" BELOW THE TOP OF THE SEAT TUBE.

5. USE A TORQUE WRENCH TO TIGHTEN SEATPOST BINDER AND ALL SADDLE MOUNTING FASTENERS.

6. NEVER USE LIGHT OR SPRAY OILS TO LUBRICATE A SEATPOST OR INSIDE THE SEAT TUBE. Never use solvents, or chemical spray cleaners to clean the inside of the seat tube. Wipe out the seat tube with a clean dry towel only. Light oils (typically used in honing) and solvents, and including chemical cleaners can attack and weaken composite bonds holding the frame together leading to breakage. Follow the seatpost and frame manufacturer instructions. See also page 74.

YOU CAN BE SEVERELY INJURED, PARALYZED OR KILLED IF YOUR IGNORE THESE WARNINGS.

APPENDIX C.

CARE AND MAINTENANCE OF CARBON FIBER FORKS & STEM

WARNING

ALWAYS SEEK PROFESSIONAL SERVICE—Incorrectly installing, adjusting, servicing, or assembling the wrong parts (handlebar stem, brake bolt, spacers and spacer positions) on your bicycle fork can cause serious damage to it. Any failure in the fork, headset, handlebar stem, or while riding can cause you to have a serious accident. All adjustments, maintenance, and any changes must be made by REI.

STOP RIDING A DAMAGED FORK & STEM IMMEDIATELY—Your fork can be seriously damaged in any crash or impact. Damage can be concealed and requires very careful inspection by a professional bike mechanic. A damaged fork and/or handlebar stem can fail without warning. Go to PART II, Section D. Inspect For Safety. Read “Understanding Composites” for information on carbon fiber.

REPLACE THE FORK WITH A NEW ONE IF THE DROPOUT TABS ARE MISSING OR DAMAGED—The dropout tabs located at the bottom of the fork dropout act as a secondary wheel retention device and can reduce the risk of the wheel disengaging from the fork if the quick release is not correctly adjusted and closed. It is possible for the tabs to become worn out or damaged through repeated wheel installation and removal, car rack use, etc. Do not file, disable or remove the secondary retention devices. If they are damaged or severely worn, replace the fork.

DO NOT MODIFY THE FORK IN ANY WAY. Do not drill holes or install mechanical clamps.

BRAKE NUT ENGAGEMENT—The brake mount is the attachment point of the front brake. A correctly size brake bolt (recessed allen nut) must be used to ensure adequate thread engagement (a minimum of 5mm) with the brake caliper mounting post. Ask REI to help you obtain the correct brake nut.

DO NOT EXCEED THE MAXIMUM STACK HEIGHT (55mm) OR LOCATE SPACERS ON TOP OF THE STEM—MAXIMUM STACK HEIGHT is a distance spacers may be stacked between the top of the head tube and the bottom of the stem. Exceeding this distance with spacers or locating spacers on top of the handlebar stem can place significant stress on the steerer tube. It could break.

DO NOT REMOVE THE 5MM SPACER ABOVE THE STEM. See Figure 34.

PERMANENTLY BONDED INSERT - Some forks have a bonded insert in place of a compression plug or star-nut. The insert can be identified by the writing on the top lip. This part must NEVER be removed and the steerer tube must NEVER be cut.

OLDER FORKS & STAR NUTS—Some forks use various star nut and top caps systems. Systems in these forks should not be changed. Do not use the compression assembly in a fork with a star nut.

Always tighten fasteners of the headset/stem system and brake with a torque wrench. Observe the manufacturer’s torque limits and loctite (thread-locking compound) recommendations for each component of the fork, stem, brake and handlebar system. Ask REI to help you. Over-tightening may cause damage and lead to fork or component failure.

YOU CAN BE SEVERELY INJURED, PARALYZED OR KILLED IN AN ACCIDENT IF YOU IGNORE THESE WARNINGS.

(continued on next page...)

PARTS OF A TYPICAL CARBON ROAD FORK

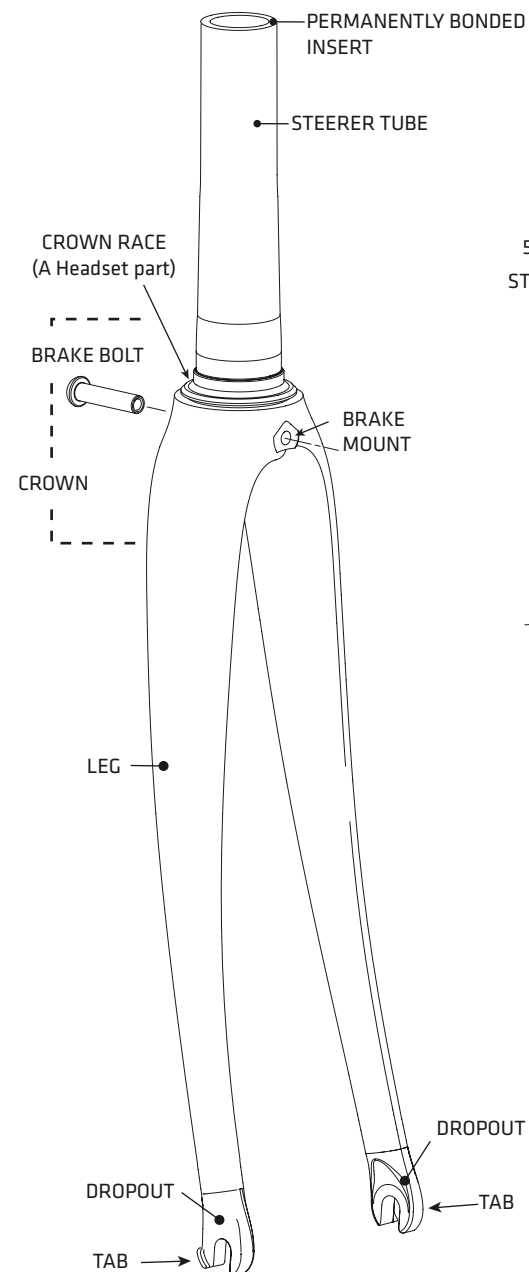

PARTS OF A TYPICAL ROAD STEM

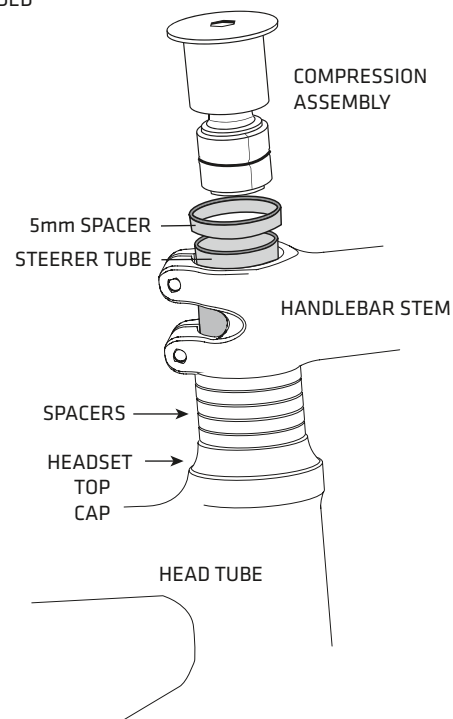

NOTE: Carbon fiber bicycle forks and stems come in many different shapes. The basic parts common to some carbon forks and handlebar stem systems are shown here.

Your fork appearance and shape may vary from what is shown.

If you have any questions about your fork, ask REI.

NOTE: DROPOUTS, STEERER, and HANDLEBAR STEM can be made from carbon fiber, metals or both in a “carbon fiber” fork.

Figure 34

(continued from previous page)

OEM vs. Aftermarket Fork Parts Compatibility

Your bicycle was shipped by Co-op Cycles with a compatible component specification. The fork, the handlebar stem, the headset parts (i.e. spacers, bearings, crown race), and the compression assembly are parts of the system. Other handlebar stems, headset parts, and compression assemblies available to you from sources other than Co-op Cycles may not be compatible.

Aftermarket Handlebar Stems

Many handlebar stem designs from many different manufacturers are available. It is impossible to provide a listing of compatibility based on availability. Don't think availability means compatibility. Here are some factors affecting compatibility:

1. A compatible handlebar stem must be compatible for use with the a compression assembly.
2. The stem must be designed for use with carbon forks having an 1 1/8 steerer tubes, without adaptation or alteration of the stem or the steerer tube. The surfaces must mate correctly.
3. The inside diameter of the stem clamping surface must be smooth and free of burrs. It must fit the outside diameter of the steerer tube snugly with the clamp bolts completely loosened. The stem surfaces in contact with the steerer must be smooth, without interruptions (large openings or holes). When clamped to the recommended tightening torque, the stem must not pinch or cause other impressions or cuts in the steerer tube. Smooth and remove any burrs with fine sand paper (220 is ideal).
4. Wedge clamping stems must not be used.

WARNING

We urge you to consult closely with REI. This will help to make sure that any aftermarket choices you make are compatible with your bike's OEM parts and will not cause serious damage to your bike.

APPENDIX D.

FULL SUSPENSION BICYCLES

If your bicycle is equipped with a rear suspension system, please read the following section carefully. The rear shock and associated moving parts on your frame require special consideration. Be sure to read and follow the shock manufacturer's setup instructions and service intervals.

Proper suspension setup is necessary to get the best performance out of your mountain bike. If you are unable to access the manufacturer's instructions, see your local REI Co-op Bike Shop.

WARNING

Adjusting your suspension settings can change the handling and braking characteristics of your bicycle. Consult the suspension manufacturer's instructions prior to making adjustments, and always check for changes in the handling and braking characteristics of the bicycle after a suspension adjustment by taking a careful test ride in a hazard-free area.

INSPECTION

Before every ride, it is important that you inspect the frame pivots, links and fasteners for any looseness, play, or damage.

Check each fastener to ensure that it is secure.

If there is any looseness or play in the pivots or linkages, or if you find any damage, such as cracks, dents, or breaks, please contact your local REI Co-op Bike Shop to have your bike inspected.

If your bicycle is equipped with an air shock: Air-sprung suspension components can lose air slowly even when the seals are in good condition. Always ensure that the pressure is correct for the rider weight.

If the suspension system fails to hold air pressure, then seal replacement may be needed. Please contact your local REI Co-op Bike Shop to have your bike inspected.

WARNING

Failure to inspect, maintain, and properly adjust the suspension system may result in suspension malfunction, which may cause you to lose control and fall.

CLEANING

Do not use a high-pressure water source to wash your bicycle, as it may force its way into the pivots and blow away lubricants as well as force contaminants into the mechanism. This can cause premature wear.

Use soapy water or a citrus-based degreaser and a soft, nylon-bristle brush to clean your bicycle and use a light spray to rinse. Do not use harsh solvents on the pivots.

Do not use cleaners that contain any type of abrasive, no matter how gentle. Wipe the individual components of the bike clean with a fresh, soft, low lint rag or towel.

MAINTENANCE

The pivot bearings and shock bushings on rear suspension systems will wear with use and time. This means that they must be inspected and replaced in order to maintain proper performance throughout the life of the bike.

Additionally, the rear shock itself requires regular maintenance. REI recommends that all bicycles equipped with a rear suspension system be regularly inspected and maintained by an REI Co-op Bike Shop to ensure safe operation.

Refer to the rear shock manufacturer's service instructions for information about maintaining the shock, including its recommended maintenance intervals.

If you notice looseness or play in the rear suspension linkages, this may indicate worn components. Contact your local REI Co-op Bike Shop to have your bike inspected.

APPENDIX E.

BICYCLE RACKS

Bicycle automobile racks are available from many different manufacturers and many different rack designs exist. They are convenient devices to transport your bike. However, any bicycle rack has the potential to seriously damage your bicycle. Damage can occur immediately due to some aspect of an incompatible or poor rack design. Damage can occur after repeated mounting and dismounting. Damage can also happen while the bike is being transported in the rack. We can't cover all the possible ways in which a rack can cause damage to your bike.

 **WARNING****READ AND FOLLOW THE RACK MANUFACTURER'S INSTRUCTIONS BEFORE MOUNTING TO YOUR BIKE.**

Both carbon and aluminum frames and forks can be damaged (crushed, cracked, or dented) by the clamps and support systems of a bike rack. Both carbon and aluminum can suffer serious abrasion damage by the movement of the bike in the rack during transport. All damage to your bike is very serious, which is why you must take extra care when choosing a bike rack and when actually mounting your bike in the rack.

WHEN MOUNTING YOUR BIKE ON A RACK:

Remove all bags, panniers, water bottles etc. to minimize wind resistance, and avoid chafing damage.

Ask REI for help choosing and using a bike rack.

See the table on the following page for more rack information.

 **CAUTION****WHEN USING A RACK WITH FORK DROPOUT CLAMPS:**

Make sure that both fork dropouts are engaged in the rack before clamping.

Make sure both dropouts are clamped with equal force. If only one dropout is engaged and the bike tips over, the leverage can exert great force that may damage the dropout.

If your bike tips over, have the dropouts examined by REI.

TYPE OF RACK DESIGN**RECOMMENDATION & CAUTIONS****CLAMPS ON TIRES / WHEELS ONLY**

This type does not use clamps on any other part of the frame or fork.

Suitable for both carbon and aluminum frames

This is typically a good design because there is no potential cracking or crushing damage to the frame or fork. Chafing wear is avoided.

FLOATING FORK MOUNT & REAR WHEEL TRAY

This design functions exactly as a quick release on your bike. The rear wheel is clamped in a tray. No other clamps are used on any other part of the frame.

Suitable for both carbon and aluminum frames

Be sure quick release on rack is properly adjusted and tightly closed.

WHEEL CLAMPS & UPRIGHT ARM CLAMP

In this design, wheels are clamped in a wheel tray and the bicycle is held upright by an arm clamping the downtube.

Do not use on bikes with carbon fiber downtubes.

When clamp is tightened, the carbon downtube can be broken. When clamp is looser, chafing can cause structural wear.

A loose clamp can allow movement and possible chafing damage. Clean the clamping area to eliminate abrasive particles, pad the clamping area and properly tighten the clamp.

NON-FLOATING FORK MOUNT & REAR WHEEL TRAY

With this type, a mechanism pulls the two sides of the fork in at the same time, and pulls both sides in the same distance.

Not recommended for either carbon or aluminum bikes.

If one dropout is slightly thicker than the other dropout, all the clamping force is applied to the thicker dropout. The high force on the one thicker dropout may crack a carbon dropout. The thinner dropout may move in the rack causing wear and abrasion. The fork blade attached to the thicker dropout takes most of the loads caused by 70 mile per hour wind and bumps. The result may be damage to your fork.

HANGER RACK

On this type, the bicycle hangs on two arms projecting aft from a trunk mounted rack.

Not recommended for either carbon or aluminum bikes.

Do not use on bikes with carbon fiber tubes.

The point loading where the arms contact the underside of the tubes may crack the tubes. Additionally the lower part of the bike is difficult to secure, and it may move, causing chafing and structural wear. Additionally when two bikes are mounted on these racks the contact points between the bikes may be cracked or chafed, causing structural damage.

PART II

APPENDIX F.

USING BICYCLE TRAINERS

Potential Damage

CAUTION

Improperly mounting a bike in a trainer, or using one that is not compatible with your particular bike frame can cause serious damage.

This kind of damage is not covered by the REI Limited Warranty.

Ask your local REI for help with trainers, the right one and the correct way to use it.

If you ride a trainer that requires removal of the front wheel and clamps the fork dropouts: Be sure your fork quick release or thru-axle is tight! Relative movement will wear parts, weaken and damage your bike.

If you ride a trainer that holds the bike up by clamping the rear quick release between two cones: consider substituting a heavy, classic all steel quick release and clamp it tight! Relative movement will wear parts, weaken and damage your bike. Note that many modern quick releases will not fit the clamping cones in this kind of trainer because their shapes are incompatible.

Be particularly cautious with a carbon frame or fork. Carbon is relatively soft, not abrasion resistant. If there is any relative movement, carbon will wear quickly.

If you ride a trainer a lot, consider using an old bike: Corrosion from sweat will take its toll. Weight is irrelevant. Save wear on your expensive components.

Trainers: Risk To Children

WARNING

KEEP CHILDREN AWAY FROM BICYCLES MOUNTED ON STATIONARY TRAINERS, EVEN WHEN THE BICYCLE IS NOT IN USE.

Spinning wheels attract children's attention and present a serious risk to young fingers.

Children have also been known to rotate cranks by hand on bicycles left unattended on stationary trainers, putting themselves at risk of serious injury.

RULES OF THE TRAIL

MOUNTAIN BIKERS, PLEASE DO YOUR PART TO MAINTAIN TRAIL ACCESS BY OBSERVING THE FOLLOWING RULES OF THE TRAIL:

RIDE ON OPEN TRAILS ONLY Respect trail and road closures (ask if uncertain), avoid trespassing on private land, and obtain permits or other authorization as may be required. Federal and state wilderness areas are closed to cycling.

LEAVE NO TRACE Be sensitive to the dirt beneath you; practice low-impact cycling. Wet and muddy trails are more vulnerable to damage. When the trailbed is soft, consider other riding options. Stay on existing trails and do not create new ones. Be sure to pack out at least as much as you pack in.

CONTROL YOUR BICYCLE! Inattention for even a second can cause problems. Obey all bicycle speed regulations and recommendations.

ALWAYS YIELD THE TRAIL Let your fellow trail users know you're coming. A friendly greeting or bell is considerate and works well. Show your respect when passing others by slowing to a walk or even stopping. Anticipate that other trail users may be around corners or in blind spots.

NEVER SCARE ANIMALS All animals are startled by an unannounced approach, sudden movement or loud noise. Give animals extra room and time to adjust to you. When passing horses, use special care and follow the directions of the horseback rider (ask if uncertain). Running cattle and disturbing wildlife are serious offenses. Leave gates as you found them, or as marked.

PLAN AHEAD Know your equipment, your ability and the area in which you are riding, and prepare accordingly. Be self-sufficient at all times, keep your equipment in good repair, and carry necessary supplies for changes in weather or other conditions. Always wear a helmet and safety gear.

The above information is a synopsis of the "Rules of the Trail" information provided by the International Mountain Bicycling Association (IMBA), a group that is dedicated to promoting environmentally sound and socially responsible off-road bicycling. For the complete text or more information on IMBA, please visit imba.com or call (303) 545-9011.

RIDE SAFE AND SMART

Always wear a helmet when riding.

Use lights, front and rear, when cycling at night and in low-visibility weather conditions.

Have a clear-sounding horn or bell to warn others of your approach.

Do not carry passengers or packages that interfere with your vision or control.

Always give pedestrians the right of way.

Reduce speed at all intersections, look both ways, then proceed with caution.

Watch for cars pulling out into traffic and car doors opening.

Know and obey all local and state traffic rules and regulations.



FOLLOW THIS CHECKLIST BEFORE EVERY RIDE. IF YOU HAVE ANY REASON TO SUSPECT THAT YOUR BICYCLE IS NOT FUNCTIONING PROPERLY, DO NOT RIDE IT

Have it inspected by your local REI. To locate your nearest REI store call 1-800-426-4840. Failure to follow this checklist and to have any potential problem inspected could lead to an accident, with risk of serious injury, paralysis or death.

USE THIS PRE-RIDE CHECKLIST TO KEEP YOUR BIKE IN PEAK CONDITION

TIRES

- Proper inflation
- Good condition; no signs of cuts or wear

WHEELS

- Quick-release levers and thru-axles secured
- Wheels true and centered in frame/fork

BRAKES

- Pads secure and aligned properly
- Brakes centered
- Brake levers symmetrical and secure
- Cables and housings free of kinks/frays
- Lever has at least 1" before bottoming against handlebar

HANDLEBAR

- Aligned and properly secured

STEM

- Aligned and properly secured

E-BIKE

- Battery secure
- Battery adequately charged
- Controller functioning properly

HEADSET

- No play or knocking, turns freely

SADDLE/SEATPOST

- Aligned and properly secured

DRIVETRAIN

- Check for over/under shifts
- Chain clean and lubed

PEDALS

- Properly secured

CRANK ARMS

- Properly secured

BOTTOM BRACKET

- No side to side play, spins freely

ACCESSORIES

- Racks, bottle cages, fenders, chain guards etc. secured

HELMET

- No cracks or breaks

Questions about any of these parts or adjustments? Our knowledgeable bike staff is happy to answer your questions.

REI MASTER TECHNICIANS ENSURE YOU GET EXPERT SERVICE

From basic maintenance to complete overhaul—even wheelbuilding—any job or question about your bike can be handled by REI Master Technicians.

REI Master Techs know bikes inside and out. An intensive certification program at the renowned Barnett Bicycle Institute in Colorado ensures it.

Every REI bike shop staff member is trained and certified by the REI Master Tech in each store, so you can count on getting consistent, knowledgeable service every time.

100% SATISFACTION GUARANTEE AND LIMITED WARRANTY

We stand behind everything we sell. If you are not satisfied with your REI purchase, you can return it for a replacement or refund within one year of purchase. REI's guarantee doesn't cover ordinary wear and tear or damage caused by improper use or accidents. If your item has a manufacturing defect in its materials or workmanship, you can return it at any time. This limited warranty gives you specific legal rights, and you may have other rights which vary from state to state.

Co-op Cycles are sold exclusively at REI: visit us at REI.com