



VALVCHEQ BACKFLOW PREVENTERS

FIGURE RP03

Reduce pressure zone device suitable for high and medium hazard rated applications
Flanged end connections



FEATURES

- Compact simple design.
- In-line and on-site serviceable.
- No special tools required for servicing.
- Lifting lugs to assist with installation.
- Designed and manufactured in accordance with AS/NZS 2845.1.
- FBE coated to AS/NZS 4158.
- Straight through flow path for maximum flow co-efficient.
- Top entry allows parts to be accessed easily.
- Stainless steel internals for superior corrosion resistance.
- Fully restrained check valve assemblies for unrivalled safety.
- Ductile Iron body for high strength and impact resistance.
- Every valve is bench tested and tracked with unique serial number.
- All internal components are repairable or replaceable.
- All internal and external bolting is stainless steel.
- Conforms to testing requirements of AS/NZS 2845.3.
- Anti-tamper test taps.
- Design conforms to all major international standards.
- Recommended for horizontal installation only.

GENERAL APPLICATION

The RP03 provides protection from both backsiphonage and backpressure of the potable water supply from contamination in high and medium hazard applications.

TECHNICAL DATA

Size range: DN 65 - 150
Temperature rating: 1 °C to 60 °C
Working pressure: PN16
End connections: Flanged AS 4087
Alternative flange drillings may be available on request



AS/NZS 2845.1 Lic WMKA 1324
SAI Global

VALVCEO BACKFLOW PREVENTERS

FIGURE RP03

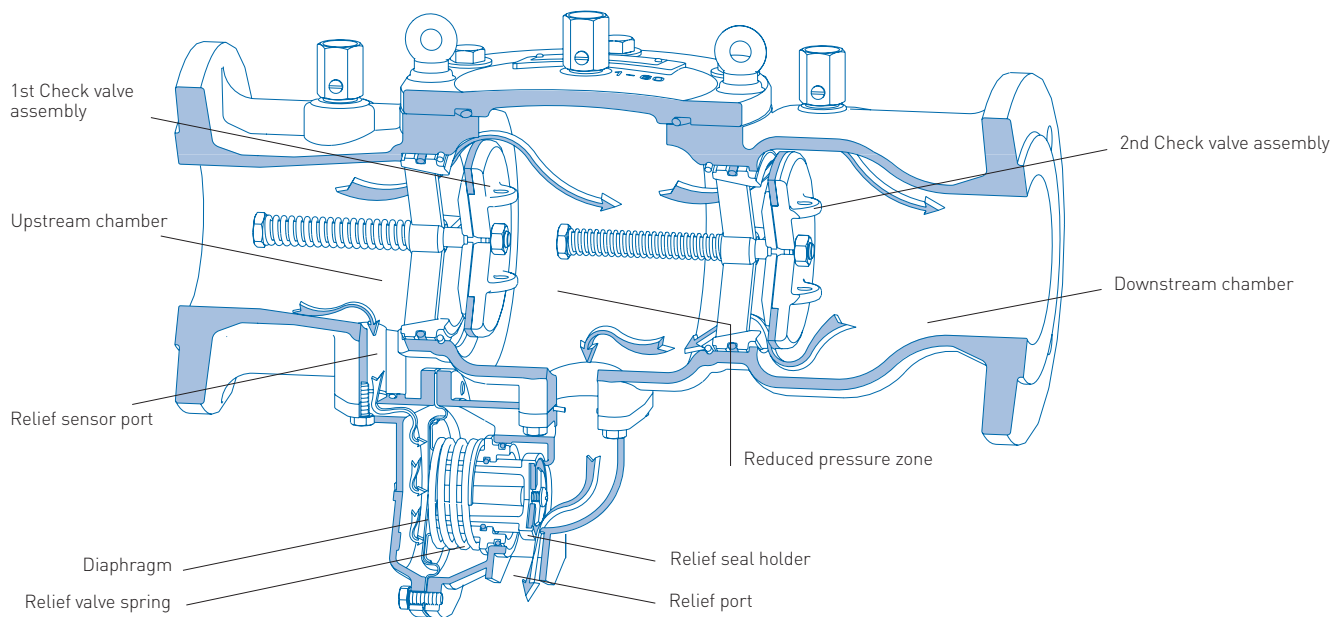

PRINCIPLE OF OPERATION

Reduced pressure zone device consists of two independently acting non-return valves in series. They are arranged to be force-loaded in the closed position. A relief valve is positioned between them and is designed to be pressure energized to vent to atmosphere when the pressure differential across the upstream non-return valve reduces to 14 kPa.

Under normal dynamic flow conditions:

Water enters the upstream chamber before the 1st check valve assembly and flows down through the relief sensor port. When sufficient water pressure is achieved (minimum of 14 kPa) the diaphragm and relief spring are energized and push the relief seal holder across the relief port to relief sealing edge closing it off from atmosphere.

Once relief port is closed, pressure builds up in the upstream chamber before the 1st check valve assembly. When this pressure is sufficient (minimum of 35 kPa) 1st check valve assembly will open allowing flow into and fill the reduced pressure zone.

The 2nd check valve assembly will open after the reduced pressure zone is full and pressurized sufficiently (minimum 7 kPa) allowing flow through the downstream chamber.

Under backpressure condition:

(Premises pressure is greater than supply pressure)

Water pressure in the downstream chamber and spring pressure force the 2nd check valve assembly closed. If the 2nd check valve assembly is fouled by debris in the open position, the backpressure with the aid of relief spring pushes the relief seal holder open. The relief port opens and allows all liquid contained in the reduced pressure zone to be relieved to atmosphere. The relief port will continue to discharge until backpressure dissipates or 2nd check valve assembly is cleared of debris.

Under backsiphonage condition:

(Negative/low pressure in mains supply)

The 1st check valve assembly will close under spring pressure. Water pressure in the upstream chamber before the 1st check valve assembly and relief sensor port will dissipate. This will result in the relief spring opening the relief port and allowing all liquid contained in the reduced pressure zone to be relieved to atmosphere.

VALVCHEQ BACKFLOW PREVENTERS

FIGURE RP03

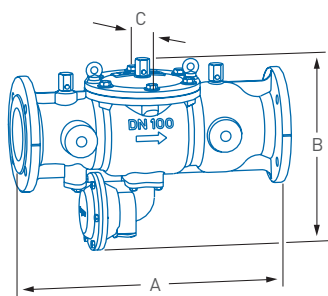

Note: valve only (VO) illustrated.

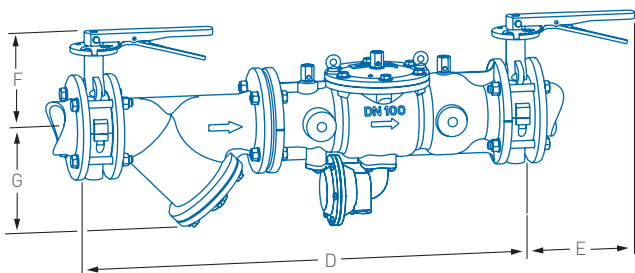

Note: butterfly valve (BFV) arrangement illustrated.

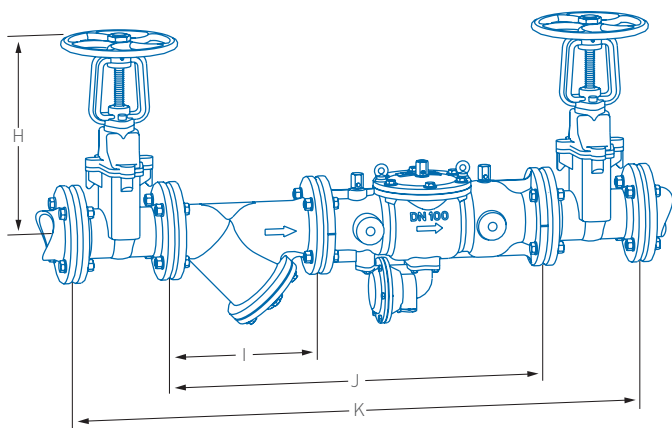

Note: resilient seated gate (RSGV) valve arrangement illustrated.

DIMENSIONS (mm)

Valve size DN	A	B	C	D	E	F	G	H	I	J	K	Mass (kg)		
												VO	BFV	RSGV
65	400	335	185	767	240	192	210	-	273	675	-	25	54	-
80	400	335	185	786	240	192	210	512	292	694	1103	25	54	91
100	535	382	230	993	240	210	235	590	352	889	1350	42	86	120
150	685	480	300	1269	240	230	390	788	470	1157	1964	80	154	205

NOTE

Dimensions are nominal to ± 1 mm.

Butterfly valve actuators change from handles to gear operators on valves sizes DN 200 and above.

Gear operation actuators available on request for butterfly valve arrangement.

Lockable actuators available on request.

VO = Mass of valve only.

BFV = Mass of complete arrangement with butterfly valves.

RSGV = Mass of complete arrangement with resilient seated gate valves.

VALVCEQ BACKFLOW PREVENTERS

FIGURE RP03

TYPICAL FLOW CHARACTERISTIC GRAPHS

DN 65 valves

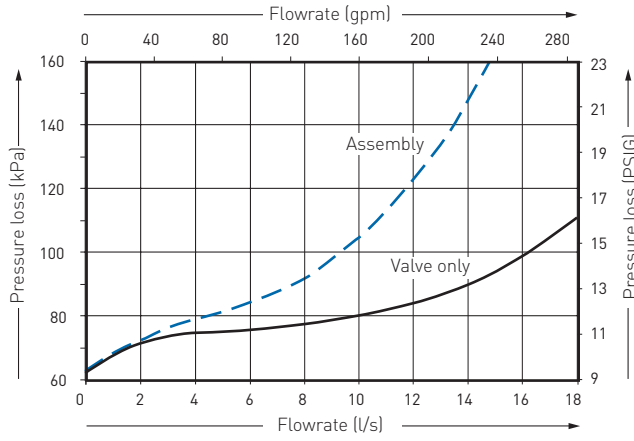

DN 80 valves

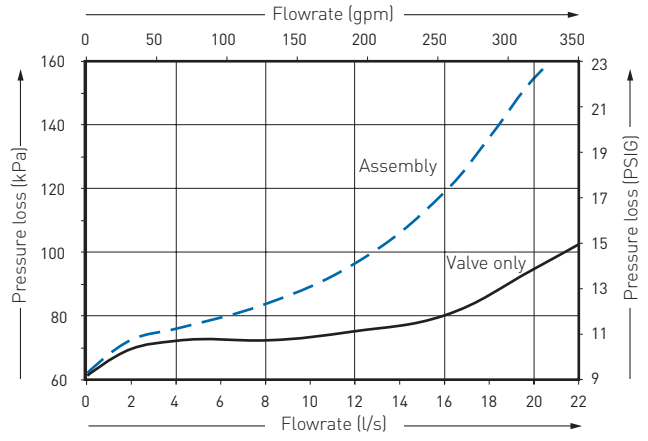

DN 100 valves

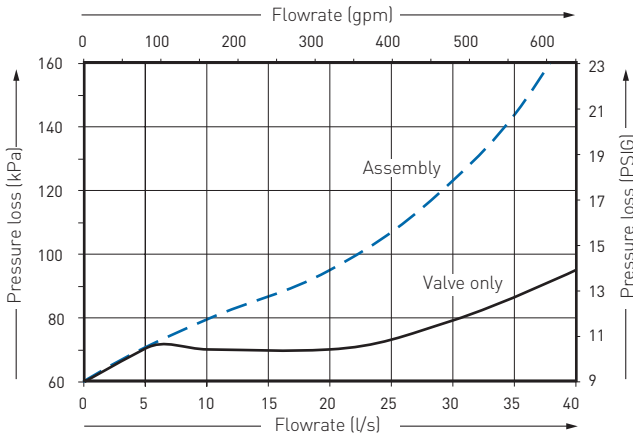

DN 150 valves

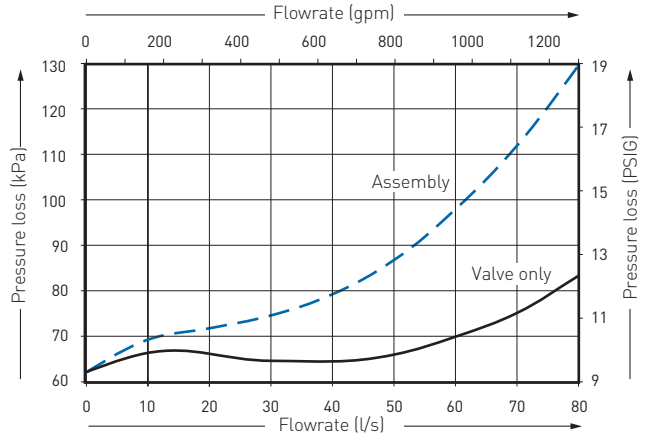

NOTE

- Complete valve assembly
- Valve only

VALVCEQ BACKFLOW PREVENTERS

FIGURE RP03

SELECTION GUIDE

Example:	100	RP03	C	CO	BF
Valve size (DN)					
Figure no.					
End connections					
C	AS 4087 Table C				
	Alternative flange drillings may be available on request				
Assembly					
VO	Valve only				
CO	Complete with isolation valves and FBE coated strainer				
FS	Fire service (supplied without strainer)				
Isolation					
BF	Butterfly valves				
BF G/Op	Butterfly valves gear actuated				
BF G/Op L	Butterfly valves gear actuated lockable				
RSGV	Resilient seating gate valves				

NOTE

All Emerson isolation valves come with the provision for locking.

TROUBLESHOOTING

Symptom	Cause	Remedy
First check valve not holding tight (reading approaches zero without holding)	<ol style="list-style-type: none"> 1. Debris fouling the check valve seal 2. Check valve seal damaged or perished 3. Check valve O-ring damaged 4. Check valve stem O-ring damaged 5. Check valve seal ring damaged 	<ol style="list-style-type: none"> 1. Inspect, clean, reverse or replace check seal 2. Inspect and replace check valve seal 3. Inspect and replace O-ring 4. Inspect and replace O-ring 5. Replace first check valve assembly
First check valve drops below 35 kPa and remains steady	<ol style="list-style-type: none"> 1. Debris fouling the check valve seal 2. Check valve seal damaged or perished 3. Check valve spring memory loss or damaged 4. Check valve stem O-ring damaged 	<ol style="list-style-type: none"> 1. Inspect, clean, reverse or replace check seal 2. Inspect and replace check valve seal 3. Replace first check valve assembly 4. Inspect and replace O-ring
Continuous discharge from relief port	<ol style="list-style-type: none"> 1. Debris fouling 1st check valve seal (static flow) 2. Debris fouling relief valve seal 3. Relief seal guide outer O-ring damaged 4. Relief seal guide inner O-ring damaged 5. Diaphragm damaged 6. Debris fouling 2nd check valve seal (static flow) (Backpressure condition) 	<ol style="list-style-type: none"> 1. Clean check valve seal 2. Clean relief valve seal 3. Replace O-ring 4. Replace O-ring 5. Replace diaphragm 6. Clean check valve seal
Second check valve not holding tight	<ol style="list-style-type: none"> 1. Debris fouling the check valve seal 2. Check valve seal damaged or perished 3. Check valve O-ring damaged 4. Check valve stem O-ring damaged 5. Check valve seal ring damaged 	<ol style="list-style-type: none"> 1. Inspect, clean, reverse or replace check seal 2. Inspect and replace check valve seal 3. Inspect and replace O-ring 4. Inspect and replace O-ring 5. Replace second check valve assembly
Relief port not opening before 14 kPa	<ol style="list-style-type: none"> 1. Diaphragm damaged 2. Relief spring memory loss 3. Relief seal holder jammed 	<ol style="list-style-type: none"> 1. Replace diaphragm 2. Replace spring 3. Inspect and clean seal holder

VALVCEQ BACKFLOW PREVENTERS

FIGURE RP03

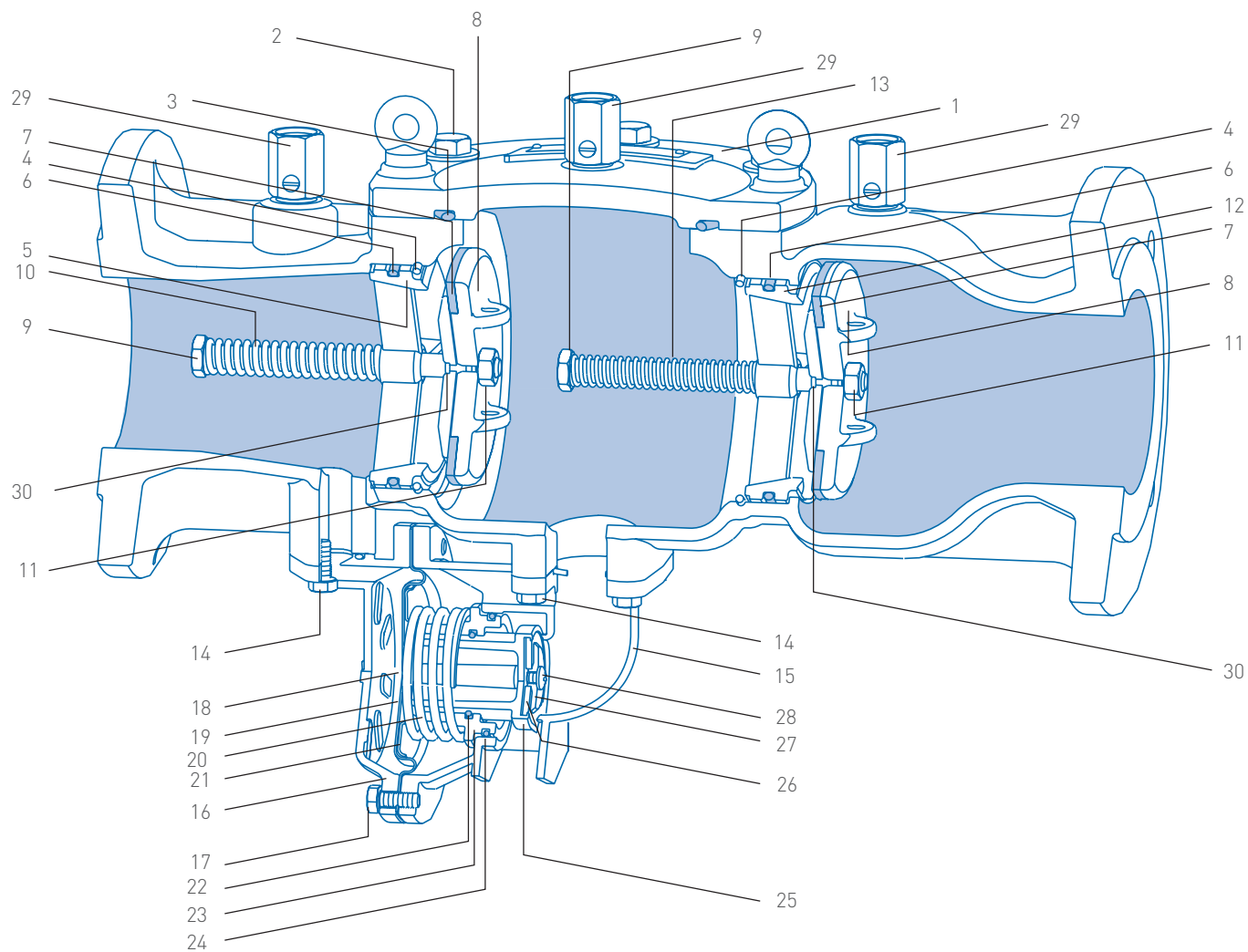

PARTS LIST

No.	Description (main valve)	No.	Description
2	Cover plate bolts	17	Relief valve assembly bolts
3	Cover plate O-ring	18	Diaphragm retaining screw
4	Check valve circlip	19	Relief valve diaphragm
5	First check valve seal ring	20	Relief valve spring
6	Check valve O-ring	21	Diaphragm retainer
7	Check valve seal	22	Relief valve seal guide inner O-ring
8	Check valve disc	23	Relief valve guide
9	Check valve stem	24	Relief valve seal guide outer O-ring
10	First check valve spring	25	Relief valve seal holder
11	Check valve retaining nut	26	Relief valve seal
12	Second check valve seal ring	27	Relief valve seal retainer
13	Second check valve spring	28	Relief valve seal retainer screw
14	Relief valve mounting fasteners	29	Test taps
15	Relief valve body	30	Check valve stem O-ring

VALVCEO BACKFLOW PREVENTERS

FIGURE RP03

Complete safety and maintenance instructions for DN 65 - 150 high hazard devices

MAINTENANCE AND TESTING REQUIREMENTS

Test after initial installation and annually for the life of the valve or service. Maintain in a working order and inspect for operational function at intervals not exceeding twelve months. The functions are to be carried out by authorized licensed backflow testers.

Main valve

As per safety precautions slowly close isolation valves and then open all three test taps (29) to drain relief port.

Remove cover plate bolts (2) and washers.

Remove cover plate (1) and cover plate O-ring (3).

With screwdriver remove 2nd check valve assembly circlip (4) utilizing cavity recess in the body casting.

NOTE

Please take care not to damage FBE coating with screwdriver.

To remove 2nd check valve assembly pull check valve stem (9) out and then up bringing the check assembly through the top entry of the valve.

With screwdriver remove 1st check valve assembly circlip (4) utilizing cavity recess in the body casting.

NOTE

Please take care not to damage FBE coating with screwdriver.

To remove 1st check valve assembly take a screwdriver and lever the assembly out by utilizing lug provided on check valve disc (8). Or slowly crack open inlet isolating valve and allow the water pressure to push the check valve assembly into the main valve body.

Shut isolating valve and remove check assembly through top entry of the valve.

Both check assemblies are mechanically the same, please use the following steps to access check valve seals (7).

Fit spanners to check valve stem head (9) and check valve retaining nut (11), turn check retaining nut anti-clockwise and remove.

Remove check valve disc (8), this exposes check valve seal (7) for servicing or replacement.

NOTE

When assembly takes place all components:

- Lubricate all O-rings.
- Stronger upstream check valve spring (10) on check valve assembly is always the 1st check valve assembly.
- Check valve seal (7) must be clean, free of any greases, moisture and debris upon assembly for a positive seal.

Relief assembly

Remove relief valve mounting fasteners (14). Pull relief valve assembly away from main valve body.

Remove relief valve assembly bolts (17).

Separate relief valve body cover (16) and relief valve body (15).

Remove relief valve diaphragm (19) and pull out relief assembly.

To access relief valve spring (20), remove diaphragm retainer screw (18) and diaphragm retainer (21).

Slide off relief valve guide (23) from relief valve seal holder (25).

To access relief valve seal (26), remove relief valve seal retainer screw (28) and relief valve seal retainer (27).

On and in relief valve guide (23), is relief valve seal guide outer O-ring (24) and relief valve seal guide inner O-ring (22).

SAFETY PRECAUTIONS

In every instance of installation or removal from the pipeline, ensure the line is not pressurized and any hazardous liquid is drained away.

Slowly close both isolating valves and then open test taps (29) to drain relief port.

VALVCHEQ BACKFLOW PREVENTERS

FIGURE RP03

Specifications for reduce pressure zone device suitable for high and medium hazard rated applications

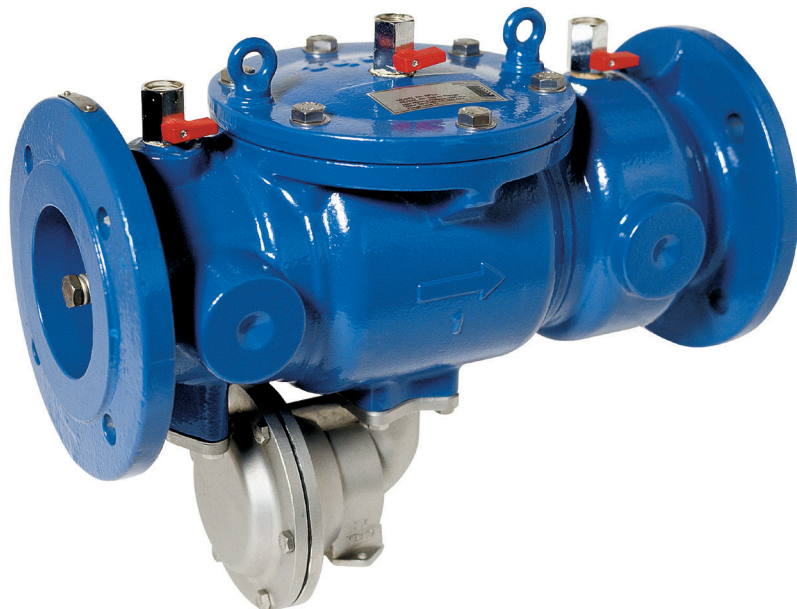

- Main valve shall be manufactured in accordance with AS/NZS 2845.1.
- Main valve shall be constructed from ductile iron and FBE coated to AS/NZS 4158.
- All internals shall be constructed from stainless steel and to have pressure rating of PN16 and a temperature rating of 60 °C.
- Main valve body shall not form part of the wetted check valve sealing area or mechanism.
- Internal parts and elastomers are to be accessible through a top entry point of the main valve to allow in-line maintenance. Valve connection shall be flanged to AS 4087.
- Valve shall also be fitted with test points with BSPT threads to allow testing to AS/NZS 2845.3.

Neither Emerson, Emerson Automation Solutions, nor any of their affiliated entities assumes responsibility for the selection, use or maintenance of any product. Responsibility for proper selection, use, and maintenance of any product remains solely with the purchaser and end user.

ValvCheQ is a mark owned by one of the companies in the Emerson Automation Solutions business unit of Emerson Electric Co. Emerson Automation Solutions, Emerson and the Emerson logo are trademarks and service marks of Emerson Electric Co. All other marks are the property of their respective owners.

The contents of this publication are presented for informational purposes only, and while every effort has been made to ensure their accuracy, they are not to be construed as warranties or guarantees, express or implied, regarding the products or services described herein or their use or applicability. All sales are governed by our terms and conditions, which are available upon request. We reserve the right to modify or improve the designs or specifications of such products at any time without notice.

Emerson.com/FinalControl