

User Manual

Original Instructions



Allen-Bradley

Guardmaster®

Guard-Locking Proximity Inputs Safety Relay

Catalog Number 440R-GL2S2P

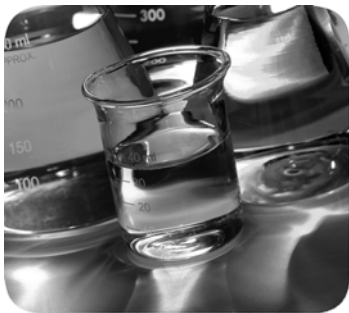

Important User Information

Read this document and the documents listed in the additional resources section about installation, configuration, and operation of this equipment before you install, configure, operate, or maintain this product. Users are required to familiarize themselves with installation and wiring instructions in addition to requirements of all applicable codes, laws, and standards.

Activities including installation, adjustments, putting into service, use, assembly, disassembly, and maintenance are required to be carried out by suitably trained personnel in accordance with applicable code of practice.

If this equipment is used in a manner not specified by the manufacturer, the protection provided by the equipment may be impaired.

In no event will Rockwell Automation, Inc. be responsible or liable for indirect or consequential damages resulting from the use or application of this equipment.

The examples and diagrams in this manual are included solely for illustrative purposes. Because of the many variables and requirements associated with any particular installation, Rockwell Automation, Inc. cannot assume responsibility or liability for actual use based on the examples and diagrams.

No patent liability is assumed by Rockwell Automation, Inc. with respect to use of information, circuits, equipment, or software described in this manual.

Reproduction of the contents of this manual, in whole or in part, without written permission of Rockwell Automation, Inc., is prohibited

Throughout this manual, when necessary, we use notes to make you aware of safety considerations.



WARNING: Identifies information about practices or circumstances that can cause an explosion in a hazardous environment, which may lead to personal injury or death, property damage, or economic loss.



ATTENTION: Identifies information about practices or circumstances that can lead to personal injury or death, property damage, or economic loss. Attentions help you identify a hazard, avoid a hazard, and recognize the consequence.

IMPORTANT

Identifies information that is critical for successful application and understanding of the product.

Labels may also be on or inside the equipment to provide specific precautions.



SHOCK HAZARD: Labels may be on or inside the equipment, for example, a drive or motor, to alert people that dangerous voltage may be present.



BURN HAZARD: Labels may be on or inside the equipment, for example, a drive or motor, to alert people that surfaces may reach dangerous temperatures.



ARC FLASH HAZARD: Labels may be on or inside the equipment, for example, a motor control center, to alert people to potential Arc Flash. Arc Flash will cause severe injury or death. Wear proper Personal Protective Equipment (PPE). Follow ALL Regulatory requirements for safe work practices and for Personal Protective Equipment (PPE).

	Preface	
	Who Should Use This Manual?	7
	Purpose of This Manual	7
	Firmware Revision History.....	7
	Summary of Changes	7
	Terminology.....	8
	Additional Resources.....	8
	Chapter 1	
Overview	Hardware Features	9
	Logic Functions.....	10
	Logic Setting 1 - Cat 1 Stop, Logic IN Off	10
	Logic Setting 2 - Cat 1 Stop with Logic IN.....	10
	Logic Setting 3 - Safe Limited Slow Speed, Logic IN Off	11
	Logic Setting 4 - Safe Limited Slow Speed with Logic IN.....	11
	Logic Setting 5...8 - Guard Locking with Delayed	
	Unlock and Automatic Reset	12
	Logic Setting 8 — Speed Status Only.....	12
	Chapter 2	
Installation	Mounting Dimensions.....	13
	DIN Rail Mounting and Removal	13
	Removal	14
	Spacing	14
	Removable Terminals.....	14
	Enclosure Considerations.....	14
	Preventing Excessive Heat	15
	Chapter 3	
Power, Ground, and Wire	Wiring Requirements and Recommendation	17
	Wire Size	17
	Terminal Torque.....	17
	Terminal Assignments.....	18
	Grounding the Controller	19
	Connecting a Power Supply	19
	Proximity Sensor Connections	20
	Guard Locking Connections	20
	Devices with Mechanical Contacts.....	20
	Safety Devices with OSSD Outputs	21
	Unlock Request Input	21
	Lock and Reset Request Input.....	22
	Lock and Unlock Signals.....	22

	Lock Outputs.....	23
	TLS3-GD2 Connections.....	23
	TLS-Z, 440G-LZ, and MAB Connections.....	23
	Multiple Guard Locking Devices and Power to Lock	24
	No Guard Locking	25
	Safety Outputs.....	25
	Single Wire Safety (SWS).....	26
	Chapter 4	
Configuration	Logic Switch Settings.....	27
	SLS1 Switch Setting.....	28
	SLS2/Time Switch Setting.....	28
	Configuration Process	29
	Chapter 5	
Diagnostic Status Indicators and Troubleshooting	Status Indicators During Power-up	31
	Status Indicators During Normal Operation.....	31
	Status Indicators During Diagnostics	32
	Chapter 6	
Pulse Testing Functions	Introduction to Pulse Testing	33
	Pulse Testing for Inputs.....	34
	Test of OSSD Outputs	34
	Chapter 7	
Ethernet Communication	Webpage	35
	Logix AOP	36
	Chapter 8	
Proximity Sensors and Targets	Proximity Sensor Selection.....	39
	Proximity Sensor Targets	39
	Chapter 9	
Example Operational Sequence Diagrams	Stop Cat 1 Example	43
	Example Schematic	43
	Sequence Diagram	44
	Sequence Steps	44
	SLS Example.....	46
	Example Schematic	46
	Sequence Diagram	47
	Sequence Steps	47

Delayed Unlock with Auto Reset Example 49
 Example Schematic 49
 Sequence Diagram 50
 Sequence Steps 50
 Status Only Example 51
 Example Schematic 51
 Sequence Diagram 52
 Sequence Steps 52

Specifications

Appendix A

General Specifications 53
 Environmental Specifications 53
 Input IN1 54
 Proximity Sensor Signals 54
 Lock Unlock Request..... 55
 Lock Unlock Signals..... 55
 Auxiliary Signal 56
 Single Wire Safety Input Signal..... 56
 Single Wire Safety Output Signal 57
 Safety/Pulse Test Outputs 57
 Response Times..... 58

Regulatory Approvals

Appendix B

Agency Certifications..... 59
 Compliance to European Union Directives..... 59
 Machine Safety Directive..... 59
 SIL Rating 60
 Performance Level/Category 60
 EMC Directive..... 60

Index 61

Notes:

Who Should Use This Manual?

Use this manual if you are responsible for designing, installing, programming, or troubleshooting control systems that use the guard locking with proximity (GLP) safety controller.

You must have a basic understanding of electrical circuitry and familiarity with safety-related control systems. If you do not, obtain the proper training before using this product.

Purpose of This Manual

This manual is a reference guide for the GLP safety controller, plug-in modules, and accessories. It describes the procedures that you use to install, wire, and troubleshoot your controller. This manual explains how to install and wire your controller. It also gives you an overview of the GLP controller system.

Firmware Revision History

Series	Firmware	Description
A	100	Initial release. Logic settings 1...4 functions only; 5...8 reserved for future use.
A	202	Added logic settings 5...8 (CU2 functionality).
A	203	New microprocessor technology (no change for user).
A	204	CU2 functionality removed. Internal testing revealed an undetected proximity sensor fault. Affected manufacturing date codes from 1601...1707.
A	205	CU2 functionality restored.
A	206	Additional EMC filtering for proximity sensors.

Summary of Changes

This manual contains new and updated information as indicated in the following table.

Topic	Page
Added Firmware Revision History section	7
Clarified power supply requirement for U.S.A. applications	19
Added correct connection of 100S contactors	24
Updated Webpage section	35
Updated Logix AOP section	36
Added statement that the GLP safety relay can operate with standard-rated proximity sensors	39
Added footnote about spacing of proximity sensors	40
Updated Stop Cat 1 Example (Sequence Diagram and Sequence Steps)	44
Updated SLS Example (Sequence Diagram and Sequence Steps)	47
Updated Delayed Unlock with Auto Reset Example (Sequence Diagram and Sequence Steps)	50

Terminology

Publication [AG-7.1](#) contains a glossary of terms and abbreviations that are used by Rockwell Automation to describe industrial automation systems. Specific terms and abbreviations that are used in this manual include:

- **Normally Closed (N.C.)** - An electrical contact whose normal state (for example, no pressure or electrical potential applied) is in the closed position.
- **Normally Open (N.O.)** - An electrical contact whose normal state (for example, no pressure or electrical potential applied) is in the open position.
- **Reaction Time** - Describes the time between the true states of one input to the ON state of the output.
- **Recovery Time** - Describes the time that is required for the input to be in the LO state before returning to the HI state.
- **Response Time** - Describes the time between the trigger of one input to the OFF state of the output.
- **Output Signal Switching Device (OSSD)** - Typically a pair of solid-state signals that are pulled up to the DC source supply. The signals are tested for short circuits to the DC power supply, short circuits to the DC common and shorts circuits between the two signals.
- **Single Wire Safety (SWS)** - A unique, safety-rated signal that is sent over one wire to indicate a safety status. The SWS can be used in Category 4, Performance Level e, per ISO 13849-1 and safety integrity level (SIL) 3, per IEC 62061 and IEC 61508.

Additional Resources

These documents contain additional information concerning related products from Rockwell Automation.

Resource	Description
Next Generation Guardmaster Safety Relay (GSR) Wiring Diagram, publication SAFETY-WD001	Provides example wiring diagrams for applications using Guardmaster® safety relays.
Industrial Automation Wiring and Grounding Guidelines, publication 1770-4.1	Provides general guidelines for installing a Rockwell Automation® industrial system.
Product Certifications website, rok.auto/certifications .	Provides declarations of conformity, certificates, and other certification details.
Allen-Bradley® Industrial Automation Glossary, AG-7.1	A glossary of industrial automation terms and abbreviations.

You can view or download publications at <http://www.rockwellautomation.com/literature/>. To order paper copies of technical documentation, contact your local Allen-Bradley distributor or Rockwell Automation sales representative.

Overview

Hardware Features

The Guard Locking Proximity (GLP) inputs special-purpose safety relay is designed to use proximity sensors to detect the safe speed of a machine. The GLP safety relay issues lock or unlock commands to a guard locking interlock based on the speed of the signals that are received from the proximity sensors.

The GLP safety relay has three rotary switches that are used to set its configuration. A logic switch sets the functionality. Two other switches set speed limits and time delay: Switch SLS1 sets the safe limited slow speed. Switch SLS2 set the safe maximum speed limit or a percentage of the timing range.

Figure 1 - GLP Safety Relay

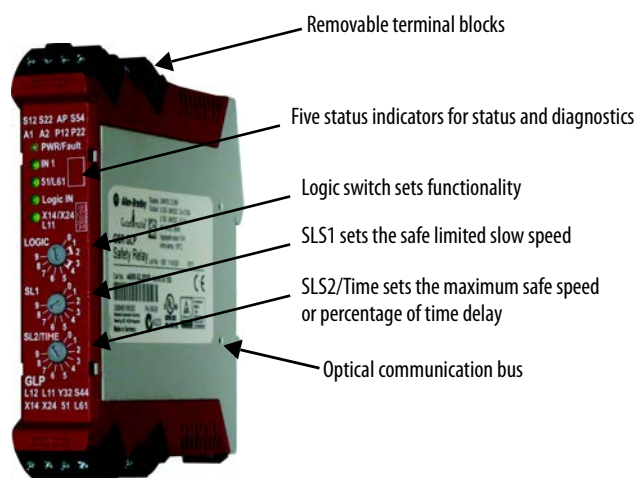

Five status indicators provide status and diagnostic information.

Table 1 - Status Indicator Information

Indicator	Description
PWR/Fault	Indicates that power is applied or a fault condition
IN1	Indicates that the safety gate is closed, input valid.
51/L61	Indicates that power is applied to unlock the guard locking interlock.
Logic IN	Indicates the presence of the Single Wire Safety input signal.
X14/X24 L11	Indicates that the safety outputs are ON.

The GLP safety relay has four removable terminal blocks; two on the top and two on the bottom.

The optical communication bus is on the sides of the housing. The GLP safety relay operates with the catalog number 440R-ENETR EtherNet/IP™ network interface to transmit its status to the machine control system over an EtherNet/IP network.

The GLP safety relay can be operated with other safety relays in the GSR family by use of the single wire safety (SWS) connection. When the GLP safety relay receives an SWS signal from other GSR relays, the GLP safety relay issues an Unlock command. When the GLP safety relay turns ON its safety output, it also turns ON its SWS output for use by other GSR safety relays.

Logic Functions

The GLP safety relay can be configured to operate in one of eight logic safety functions.

Logic Setting 1 - Cat 1 Stop, Logic IN Off

You initiate a stop command by pressing the unlock push button. The GLP safety relay issues an immediate stop command from the Y32 auxiliary output to the machine control system. When the GLP safety relay determines that the proximity sensor speed has dropped below the SLS1 setting, it starts the Frequency Measuring Timer that SLS1 specifies. If the proximity sensor speed remains below the SLS1 setting, the GLP safety relay turns OFF its safety outputs and powers the guard locking interlock through 51 and L61 to unlock the gate.

TIP If the Reset button is pressed within the Frequency Measuring Time, the GLP safety relay turns the Y32 auxiliary output back ON.

If the proximity sensor speed does not decrease below the SLS1 setting, the GLP safety relay continues to wait with the 51/L61 status indicator flashing, and the safety gate remains locked. Once the proximity sensor speed drops below SLS1 setting, the GLP safety relay begins the Frequency Measurement timer. The proximity sensor speed must remain below SLS1 during the Frequency Measurement timer.

The SWS signal at wiring terminal L12 is ignored.

Logic Setting 2 - Cat 1 Stop with Logic IN

You initiate a stop command by either pressing the unlock push button or turning off the single-wire safety signal at wiring terminal L12. The GLP safety relay issues an immediate stop command from the Y32 auxiliary output to the machine control system. When the GLP safety relay determines that the proximity sensor speed has dropped below the SLS1 setting, it starts the Frequency Measuring Timer that SLS1 specifies. If the proximity sensor speed remains below the SLS1 setting, the GLP safety relay turns OFF its safety

outputs and powers the guard locking interlock through 51 and L61 to unlock the gate.

TIP If the SWS input turns back ON or if the Reset button is pressed within the Frequency Measuring Time, the GLP safety relay turns the Y32 auxiliary output back ON.

If the proximity sensor speed does not decrease below the SLS1 setting, the GLP safety relay continues to wait with the 51/L61 status indicator flashing, and the safety gate remains locked. Once the proximity sensor speed drops below SLS1 setting, the GLP safety relay begins the Frequency Measurement timer. The proximity sensor speed must remain below SLS1 during the Frequency Measurement timer.

Logic Setting 3 - Safe Limited Slow Speed, Logic IN Off

You initiate a slow speed command by pressing a momentary push button. The GLP safety relay issues a slow speed command to the machine control system by turning terminal Y32 ON. When the GLP safety relay determines that the speed of the proximity signals is less than the SLS1 setting, the GLP safety relay issues an unlock command to the guard locking interlock, while keeping its safety outputs ON. If the speed of the machine exceeds the SLS1 setting, the GLP safety relay turns its safety outputs OFF.

The single wire safety signal at wiring terminal L12 is ignored.

Logic Setting 4 - Safe Limited Slow Speed with Logic IN

The single wire safety signal at wiring terminal L12 must be active to turn on the GLP safety relay outputs.

You initiate a slow speed command by pressing the unlock push button. The GLP safety relay issues a slow speed command to the machine control system by turning terminal Y32 ON. When the GLP safety relay determines that the speed of the proximity signals is less than the SLS1 setting, the GLP safety relay issues an unlock command to the guard locking interlock, while keeping its safety outputs ON. If the speed of the machine exceeds the SLS1 setting, the GLP safety relay turns its safety outputs OFF.

When the single wire safety signal at terminal L12 becomes inactive, the GLP safety relay initiates a shutdown. If the machine is running at production speed, the GLP safety relay turns on Y32. When the proximity speed falls below the safely limited speed, the GLP safety relay turns OFF its outputs. If the machine is already running at safe limited slow speed, the GLP safety relay turns off its safety outputs and issues an unlock command to the guard locking interlock.

Logic Setting 5...8 - Guard Locking with Delayed Unlock and Automatic Reset

The GLP safety relay uses two timers to delay the turning ON of the safety outputs and unlocking the gate.

When the proximity sensor speed falls below SLS1, the GLP safety relay starts the Frequency Measurement timer. The timer duration is dependent on the SLS1 setting. The GLP safety relay waits to verify that the proximity sensor speed is maintained below SLS1. For slower SLS1 settings, the GLP safety relay waits longer. For higher SLS1 settings, the GLP safety relay responds a little faster.

If the proximity sensor speed is maintained below SLS1, the GLP safety relay turns on the X14, X24, Y32, and L11 outputs. The GLP safety relay also starts the unlock timer.

After the unlock timer expires, the GLP safety relay turns on the 51 and L61 outputs, which unlock the safety gate.

A combination of the Logic switch and SLS2 sets the duration of the unlock timer. The Logic switch sets a range of delay and the SLS2 switch sets a percentage of that range.

As the speed of the proximity sensors crosses (increasing or decreasing) the SLS1 setting, the outputs and locking functions are performed automatically. The frequency measurement and unlock timers only apply when the proximity sensor speed decreases below the SLS1 setting.

The S12, S22, S44, and S54 inputs do not have any functionality and do not need any connections.

Logic Setting 8 — Speed Status Only

This logic setting does not control a guard locking interlock. This setting ignores the unlock, lock, L12 inputs, and also the safety inputs S12 and S22. When the proximity sensors measure speed that is below SLS1, all outputs are OFF. When the speed is greater than SLS1, but less than SLS2, the 51 and L61 terminals are high and the 51/L61 status indicator is ON. When the speed exceeds SLS2, all outputs (51, L61, X14, X24, Y32, and L11) are high and the 51/L61 and X14/X24 L11 status indicators are ON. When the speed crosses the SLS1 and SLS2 levels, the outputs turn ON and OFF automatically.

Installation

This chapter explains the mounting and terminal removal procedures. It also provides information to select the proper enclosure and help prevent overheating.

Mounting Dimensions

Figure 2 - Dimensions [mm (in.)]

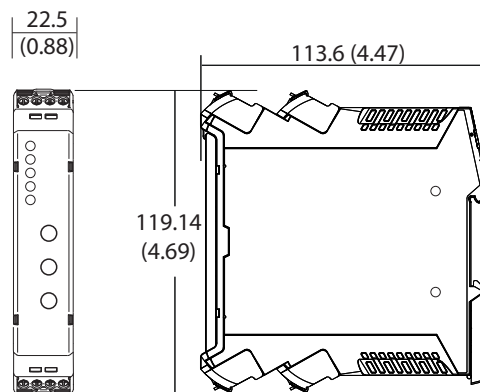

DIN Rail Mounting and Removal

The GLP safety relay mounts onto 35 mm DIN rail: 35 x 7.5 x 1 mm (EN 50022 - 35 x 7.5).

1. Hold the top at an angle.
2. Slide down until the housing catches the rail.
3. Swing the bottom down and push until the latch clips onto the rail.

Figure 3 - DIN Rail Mounting

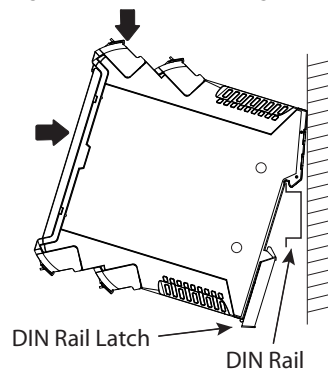

Removal

To remove the GLP safety relay, use a screwdriver to pry the DIN rail latch downwards until it is in the unlatched position. Then, swing the module up.

Spacing

The GLP safety relay can be mounted directly next to other GSR safety relays. When the catalog number 440R-ENETR EtherNet/IP network interface is used, the GSR must be mounted within 10 mm (0.4 in.) of adjacent modules to maintain effective communication.

For adequate ventilation, maintain a space of 50.8 mm (2 in.) above and below the relay.

Removable Terminals

The GLP safety relay has removable terminals to ease wiring and replacement.

Figure 4 - Removable Terminals

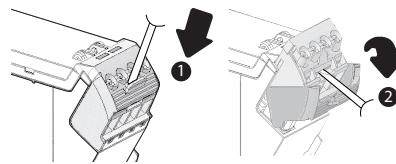

1. Insert the tip of a small, screwdriver into the slot near the terminal screws.
2. To unlock the terminal block, rotate the screwdriver.

The terminal block can then be removed from the housing.

Enclosure Considerations

Most applications require installation in an industrial enclosure to reduce the effects of electrical interference and environmental exposure. Pollution Degree 2 is an environment where normally only non-conductive pollution occurs except that occasionally temporary conductivity that is caused by condensation can be expected. Overvoltage Category II is the load level section of the electrical distribution system. At this level, transient voltages are controlled and do not exceed the impulse voltage capability of the products insulation.

This equipment is intended for use in a Pollution Degree 2 industrial environment, in overvoltage Category II applications (as defined in IEC 60664-1), at altitudes up to 2000 m (6562 ft) without derating. This equipment is considered Group 1, Class A industrial equipment according to IEC/CISPR 11. Without appropriate precautions, there may be difficulties with electromagnetic compatibility in residential and other environments due to conducted and radiated disturbances.

This equipment is supplied as open-type equipment. It must be mounted within an enclosure that is suitably designed for those specific environmental conditions that are present and appropriately designed to help prevent personal injury as a result of accessibility to live parts. The enclosure must have suitable flame-retardant properties to help prevent or minimize the spread of flame, complying with a flame spread rating of 5VA, V2, V1, V0 (or equivalent) if non-metallic. The interior of the enclosure must be accessible only by the use of a tool. Subsequent sections of this publication may contain additional information regarding specific enclosure type ratings that are required to comply with certain product safety certifications.

For more information, see:

- Industrial Automation Wiring and Grounding Guidelines, Rockwell Automation publication [1770-4.1](#), for additional installation requirements.
- NEMA Standard 250 and IEC 60529, as applicable, for explanations of the degrees of protection that are provided by different types of enclosure.

Preventing Excessive Heat

For most applications, normal convective cooling keeps the relay within the specified operating range. Verify that the specified temperature range is maintained. Proper spacing of components within an enclosure is usually sufficient for heat dissipation.

In some applications, other equipment inside or outside the enclosure can produce a substantial amount of heat. In this case, place blower fans inside the enclosure to help with air circulation and to reduce “hot spots” near the controller.

Additional GLP safety relay cooling provisions might be necessary when high ambient temperatures are encountered. Do not bring in unfiltered outside air. Place the controller in an enclosure to help protect it from a corrosive atmosphere. Harmful contaminants or dirt could cause improper operation or damage to components. In extreme cases, you may need air conditioning to help protect against heat buildup within the enclosure.

Notes:

Power, Ground, and Wire

Wiring Requirements and Recommendation



ATTENTION: Before you install and wire any device, disconnect power to the system.



ATTENTION: Calculate the maximum possible current in each power and common wire. Observe all electrical codes that dictate the maximum current allowable for each wire size. Current above the maximum ratings may cause wiring to overheat, which can cause damage.

- Allow for at least 50 mm (2 in.) between I/O wiring ducts or terminal strips and the relay.
- Route incoming power to the relay by a path separate from the device wiring. Where paths must cross, their intersection should be perpendicular.
- Do not run signal or communication wiring and power wiring in the same conduit. Wires with different signal characteristics should be routed by separate paths.
- Separate wiring by signal type. Bundle wiring with similar electrical characteristics together.
- Separate input wiring from output wiring.
- Label wiring to all devices in the system. Use tape, shrink-tubing, or other more dependable means for labeling purposes. In addition to labeling, use colored insulation to identify wiring based on signal characteristics. For example, you may use blue for DC wiring and red for AC wiring.

Wire Size

Each terminal can accommodate copper wire with size from 0.2...2.5 mm² (24...14 AWG). Use copper that withstands 60/75 °C (140/167 °F).

Terminal Torque

Torque terminals to 0.4 N·m (4 lb·in).

Terminal Assignments

Some terminals are designed to have one specific function. Some terminals can perform multiple functions; these terminals must be configured during a power-up routine.

Figure 5 - Terminal Identification

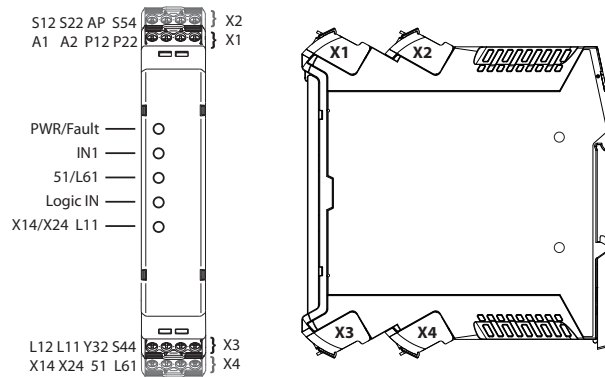

Terminal	Function
A1	+24V Supply (+10%, -15%)
A2	24V Common
AP	Power Supply for Proximity Sensors
P12	Proximity Sensor Input Channel 1
P22	Proximity Sensor Input Channel 2
S12	Safety Input for Channel 1
S22	Safety Input for Channel 2
S44	Reset and Lock Request Input
S54	Guard Locking Unlock Request Input
Y32	Auxiliary Non-safety Output
L11	Single Wire Safety Output
L12	Single Wire Safety Input
51	Guard Locking Solenoid Output Channel 1 (High Side)
L61	Guard Locking Solenoid Output Channel 2 (Low Side, High Side, or Logic Link Output)
X14	Configured as either a pulse test output that is expected at one of the safety input channels or an OSSD safety output
X24	Configured as either a pulse test output that is expected at one of the safety input channels or an OSSD safety output

Grounding the Controller

There are no special grounding requirements. Terminal A2 must be connected to the common of a 24V supply.

Connecting a Power Supply

An external 24V DC power supply source must provide power for the GLP safety relay.

To comply with the CE (European) Low Voltage Directive (LVD), a DC source compliant with safety extra low voltage (SELV) or protected extra low voltage (PELV) must power the GLP safety relay.

To comply with the USA NFPA 79, a DC power source compliant with a protected extra low voltage (PELV) must power the GLP safety relay. That is, the 0V must be connected to protective earth.

The following Bulletin 1606 power supply catalog numbers are SELV- and PELV-compliant.

- 1606-XLP30E
- 1606-XLP50E
- 1606-XLP50EZ
- 1606-XLP72E
- 1606-XLP95E
- 1606-XLDNET4
- 1606-XLSDNET4

Figure 6 - Power Supply Connections

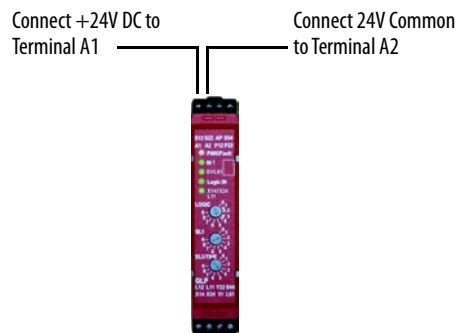

Proximity Sensor Connections

Figure 7 - PNP Proximity Sensor Connections

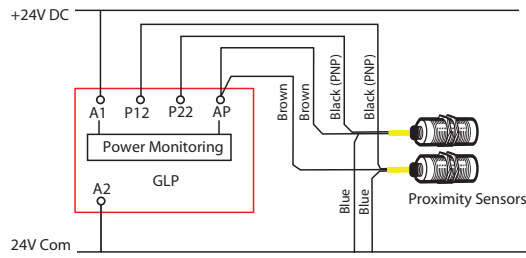
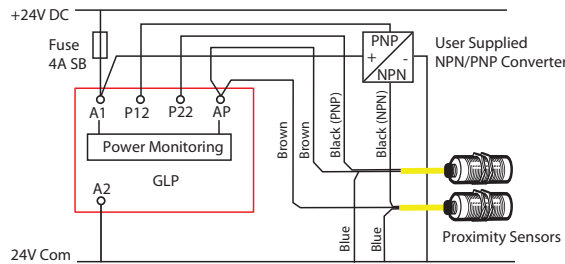

Figure 8 shows how to connect an NPN (sinking) proximity sensor. You must provide an NPN to PNP converter. The converter should get power from AP and have the same ground reference as the GLP safety relay. When an NPN/PNP converter is used, a 4 A slow-blow fuse is required, and the NPN/PNP power (+) must be connected after the fuse.

Figure 8 - PNP and NPN Proximity Sensor Connections



Guard Locking Connections

Devices with Mechanical Contacts

Guard locking devices, like the TLS3-GD2 guard locking switch, have mechanical contact outputs, where the solenoid lock monitoring contacts are typically connected in series with the gate monitoring contacts. Some models of the TLS3-GD2 guard locking switch allow you to monitor the gate and solenoid contacts separately. With its sleek, narrow body, the GLP safety relay has only one set of safety inputs, so the series connection of the gate and solenoid contacts are required because the gate must be both closed and locked for production speed operations.

Figure 9 shows an example of the wiring connections from the GLP safety relay to a TLS3-GD2 guard locking switch. X14 and X24 generate test pulses that S12 and S22 receive. The test pulses check for short circuit conditions, which, if detected, turns off the GLP safety outputs.

Figure 9 - Example Connections to Mechanical Contacts (TLS3-GD2)

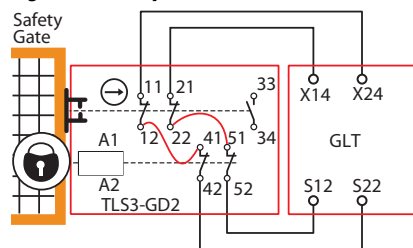

Because the TLS3-GD2 guard locking switch has multiple contacts in series, the maximum safety performance rating is Cat 3 PLd and SIL 2.

TIP Pulse test output X14 can be connected to either S12 or S22. Pulse test output X24 can be connected to either S12 or S22.

Safety Devices with OSSD Outputs

Devices, such as the TLS-Z guard locking switch, 440G-LZ guard locking switch, and Bulletin 442G Multifunction Access Box (MAB) have current-sourcing PNP semiconductor outputs (OSSD), which send their own pulse-tested safety signals to the GLP safety input terminals. These devices must have a common power-supply reference with the GLP safety relay.

Figure 10 - Example Connections to TLS-Z, 440G-LZ, or MAB

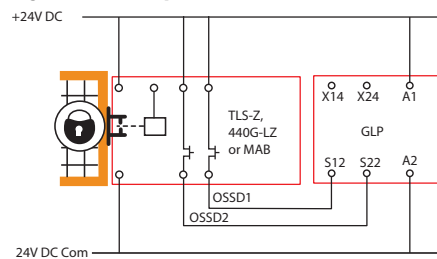

TIP OSSD1 can be connected to either S12 or S22 and OSSD2 can be connected to either S12 or S22.

When using the TLS-Z and 440G-LZ guard locking switches, the maximum safety performance rating is Cat 4 PLe and SIL 3.

Unlock Request Input

The Unlock Request input can be connected to the 24V supply through a momentary, normally open push button switch or to a 24V sourcing output of a programmable logic controller (PLC), where the PLC turns the request ON or OFF. Some examples of Rockwell Automation® PLC output modules are shown in [Figure 11](#).

The unlock request is connected to Terminal S54.

Figure 11 - Unlock Request Wiring

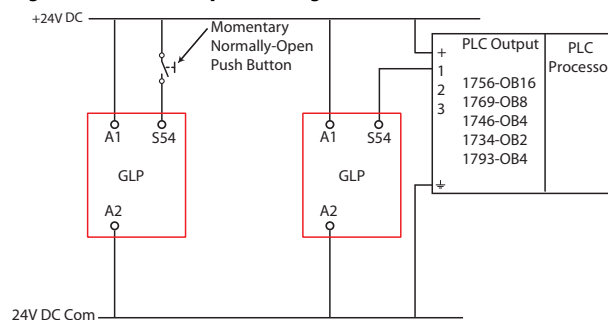

Lock and Reset Request Input

The Lock and Reset Input can be connected to the 24V supply through a momentary, normally open push button switch or to a 24V sourcing output of a PLC, where the PLC turns the request ON or OFF. Some examples of Rockwell Automation PLC output modules are shown in [Figure 12](#).

In some safety system applications, the reset signal also serves as a monitoring function. For example, when the safety outputs are driving safety contactors, the normally closed contacts of the safety contactors should be connected in series with lock and reset circuit.

If an unlock request is made, and the machine speed has not dropped below the SLS1 setting, pressing the Reset button cancels the unlock request.

The lock and reset request is connected to Terminal S44.

Figure 12 - Lock Request Wiring

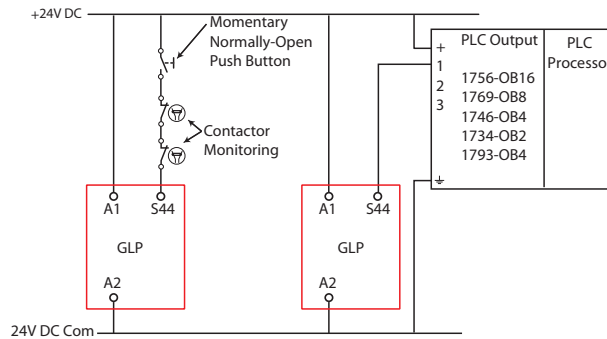

Lock and Unlock Signals

The GLP safety relay is designed to ignore incidental actuations or stuck conditions on the Lock and Unlock inputs. The lock and unlock signals must be actuated for a duration between 0.25...3 seconds. The GLP safety relay ignores signal durations that are too short or too long.

Figure 13 - Required Signal Duration

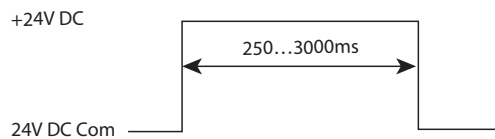

Lock Outputs

Terminals 51 and L61 perform the solenoid lock command. There are various connection possibilities, and the GLP safety relay detects the type of connection during configuration.

TLS3-GD2 Connections

Figure 14 shows a connection from a GLP safety relay to one TLS3-GD2 guard locking switch. Terminal 51 is connected to A1 and terminal L61 is connected to A2.

With this arrangement, the X14/X24 L11 status indicator flashes two times during the configuration process.

Figure 14 - Single TLS3-GD2 Connection

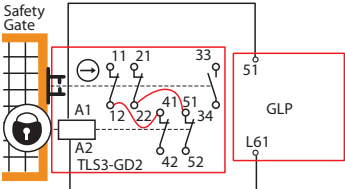

TLS-Z, 440G-LZ, and MAB Connections

Figure 15 shows one connection from a GLP safety relay to one TLS-Z guard locking switch, 440G-LZ guard locking switch, and Bulletin 442G Multifunction Access Box (MAB). Terminal 51 is connected to A1 and terminal L61 is left open. The GLP safety relay and guard locking switch must have a common reference.

With this arrangement, the X14/X24 L11 status indicator flashes one time during the configuration process.

Figure 15 - Single TLS-Z, 440G-LZ, or MAB Connection

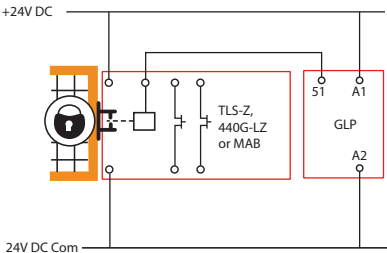

Multiple Guard Locking Devices and Power to Lock

When multiple guard locking devices must be connected to one GLP safety relay, an interposing relay or interposing relays may be required; the connection depends on the lock signal/coil characteristics. The solenoids would be driven by the contacts of the interposing relays.

TIP The lock signal of TLS-Z and 440G-LZ guard locking switches draw under 4 mA, which allows you to connect the lock signal of multiple switches in parallel.

The interposing relays must also be used to for those applications where Power to Lock guard locking is required.

IMPORTANT The GLP safety relay requires a suppression diode, as shown in [Figure 16](#), for proper operation.

Some devices, like the TLS3-GD2 guard locking switch, 440G guard locking switch, and Bulletin 100S safety contactors (with electronic coils) have built-in diodes, so an external diode is not required.

With CR1 connected between 51 and L61, the X14/X24 L11 status indicator flashes two times during the configuration process. With two relays (CR1 connected between 51 and ground and CR2 connected between L61 and ground), the X14/X24 L11 status indicator blinks one time during the configuration process.

The 700-HPSXZ24 relay can be connected between 51 and L61. The 100S contactors cannot be connected between 51 and L61. The 100S contactors must be connected between 51 and 0V or L61 and 0V.

Figure 16 - Interposing Relay Connections

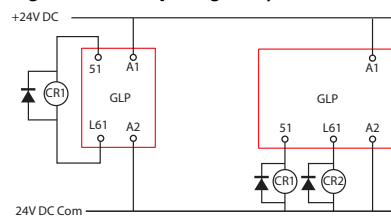

No Guard Locking

If no guard locking is required for Stop Cat 1 or SLS functions, then 51 and L61 can be left open. The safety inputs S12 and S22 must be connected to 24V DC. With this arrangement, the X14/X24 L11 status indicator blinks one time during the configuration process.

Figure 17 - No Guard Locking Connections

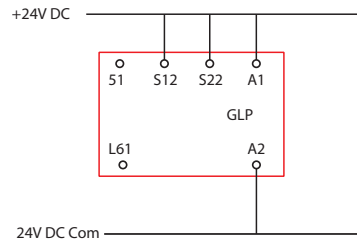

Safety Outputs

Terminal X14 and X24 can be configured as pulse test outputs or safety outputs. Start the configuration process from 9 to configure X14 and X24 as pulse test outputs. Start the configuration process from 0 to configure X14 and X24 as safety outputs.

When configured as pulse test outputs, the GLP safety relay continuously provides 24V DC combined with short test-pulse signals on terminals X14 and X24. This configuration is used in applications with guard locking devices that have mechanical contacts. The purpose of the pulse testing is to test for the following short-circuit conditions:

- Between X14 and X24
- From X14 or X24 to 24V DC
- From X14 to X24 to 24V common

[Figure 18](#) shows an example wiring connection of the pulse testing outputs (X14 and X24) connected to a TLS3-GD2 guard locking switch. The output signals are fed through the mechanical contacts and back to the safety inputs (S12 and S22) of the GLP safety relay.

Figure 18 - Pulse Test Output Connections

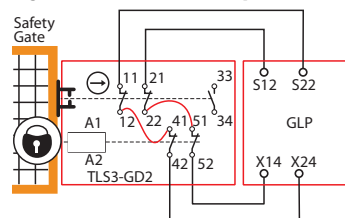

When configured as safety outputs, terminals X14 and X24 are safety outputs. The safety outputs are only turned ON when safe conditions are met. When configured as safety outputs, these terminals test for short circuits when they are turned ON. The safety outputs are commonly referred to as OSSD outputs.

Figure 19 shows an example wiring connection of the safety outputs to two contactors. When solenoid type loads are used, use a protective diode to suppress reverse voltage spikes when the contactors turn OFF.

Figure 19 - Safety Output Connections

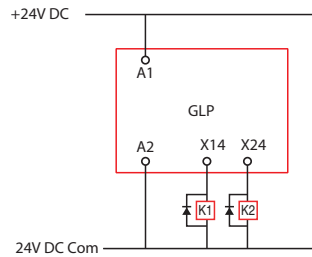

Single Wire Safety (SWS)

The GLP safety relay has two single wire safety connections: one input (terminal L12) and one output (terminal L11). These terminals can only be connected to other devices that support single wire safety.

Use of the SWS input is determined during configuration. When used, the SWS input must be ON to lock the safety gate and reset the safety outputs (turn them ON). When the SWS input turns off, the GLP safety relay turns its safety outputs OFF and performs an unlock request.

There can be many variations and combinations of series and parallel connections of the SWS. Each L11 terminal can be connected to up to ten L12 terminals.

TIP Connecting two or more L11 terminals together is not allowed.

Figure 20 shows an example wiring diagram with SWS input from a GSR DI safety relay and SWS output connection to a GSR EM expansion in parallel with a GSR DIS relay. The safety relays must have a common power reference (24V common).

Figure 20 - Single Wire Safety Connections

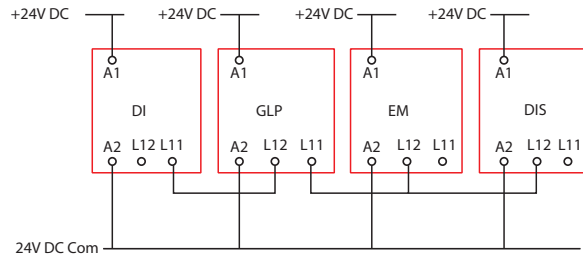
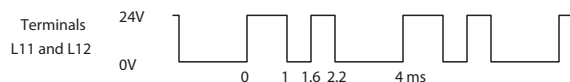

Figure 21 shows the characteristics of SWS signal when it is active. It starts with a 1-ms pulse, followed 600 μ s later by a 600- μ s pulse. This waveform is repeated every 4 ms. When inactive, the SWS is 0V.

Figure 21 - SWS Waveform



Configuration

The GLP safety relay has three multi-position switches on its front panel. These switches set the configuration of the GLP safety relay.

Logic Switch Settings

The Logic switch determines the operating function of the GLP safety relay and is used to set the configuration.

Table 2 - Logic Switch Setting

Switch 1 Setting	Lock/ Unlock Door Control Out Configuration	Application	Logic in
0	Configuration 1...8 Program mode X14 and X24 configured as OSSD Outputs		
1	Guard Locking Power to Release	Cat 1 Stop	Logic in OFF
2			Logic in AND IN1
3		Safely Limited Speed	Logic in OFF
4			Logic in AND IN1
5	Guard Locking Power to Release Delayed Unlock Automatic Reset (configuration from "0" only)	On-delay 1...10 s	Logic in OFF
6		On-delay 3...30 s	Logic in OFF
7		On-delay 30...300 s	Logic in OFF
8 (1)		On-delay 300...3000 s	Logic in OFF
8 (2)	Speed1 and Max Speed status only (Configuration from "9")	Status only	Logic in OFF
9	Configuration 1...4 Program mode X14 and X24 are configured as Pulse Tested Outputs for the S12 and S22 Inputs 5...7 Program mode is not allowed 8 for speed status only with X14 and X24 as OSSD Outputs.		

SLS1 Switch Setting

SLS1 is a 10-position switch that determines the safe limited slow speed, as detected by the proximity sensors, or the Safe Stop Threshold (Speed1).

Switch SLS1 applies to all eight logic settings.

Table 3 - SLS1 Settings

SLS1 Switch Setting	Maximum SLOW Speed	Frequency Measuring Time
0	0.5 Hz	10100 ms
1	1 Hz	5050 ms
2	2 Hz	2550 ms
3	3 Hz	1750 ms
4	4 Hz	1350 ms
5	5 Hz	1100 ms
6	6 Hz	950 ms
7	7 Hz	800 ms
8	8 Hz	700 ms
9	10 Hz	600 ms

SLS2/Time Switch Setting

SLS2/Time is a 10-position switch.

When the Logic Switch is set to positions 1...4, SLS2/Time determines the safe limited fast speed, as detected by the proximity sensors. The safety outputs turn OFF when the speed exceeds the frequency that is shown in [Table 4](#). When set to 0, the GLP safety relay does not test for maximum speed.

When the Logic Switch is set to positions 5...8, SLS2/Time determines the time delay from 10...100% of the Range set by the Logic position.

Time Delay = (10%...100% x Time Range) + Frequency Measuring Time



ATTENTION: When the frequency of the objects that pass in front of the proximity sensors exceeds the sensors capability, the proximity sensors give a false signal. To help protect against this potential unsafe condition, you must set SLS2/Time to a value that does not exceed the maximum frequency rating of the proximity sensors.

Table 4 - SLS2/Times Settings

SLS2/Time Switch Setting	Safe Maximum Speed Configuration 1...4 and 8 (Configured from 9)	Time Configuration 5...8 (Configured from 0)
0	No limit	10%
1	10 Hz	20%
2	20 Hz	30%
3	50 Hz	40%
4	100 Hz	50%
5	200 Hz	60%
6	500 Hz	70%
7	1000 Hz	80%
8	2000 Hz	90%
9	3000 Hz	100%

Use a small slotted screwdriver to set the switches to the desired setting. The configuration switches are multi-position switches with a limited rotation.

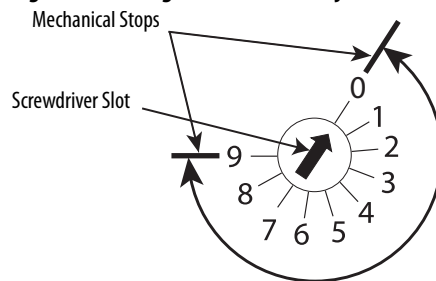
Figure 22 - Configuration Switch Adjustment

IMPORTANT Adjust the switches gently and do not turn past the mechanical stops.

Configuration Process

Configuration is a five-step process. The process requires the wiring to the GLP safety relay to be completed. During the configuration process, GLP safety relay sends out test pulses to determine how it is wired and then configures the internal parameters to match the application.

The GLP safety relay is configured in five steps:

1. With the power OFF, set the switches for configuration.

Set the Logic switch to:

- 0 if you want X14 and X24 configured as OSSD safety outputs. They turn ON simultaneously as the L11 SWS output.
- 9 if you want to use X14 and X14 as test pulse outputs that the GLP safety relay expects to receive at S12 and S22 inputs.
- You must always set the Logic Switch to 0 or 9 during configuration, even if you only want to change SLS1 or SLS2/Time.

Set SLS1 to 0.

Set SLS2/TIME to 0.

2. Apply power.

The PWR/Fault status indicator flashes red continuously. The prior configuration in the EEPROM is erased and the device now prepared for a new configuration.

3. Adjust the Logic, SLS1, and SLS2/Time switches.

After 500 ms, the new configuration parameters are acknowledged. Then, after 300 ms, the new parameter is stored in the EEPROM, the power status indicator is solid green.

TIP You can change (or readjust) the switch settings during Step 3 and 4. The power status indicator momentarily flashes red again.

4. Verify the settings by counting the blink rates of the status indicators.

The status indicators flash for 0.5 seconds to indicate the switch setting. The number of flashes is equal to the switch setting. The blinking repeats after a two-second pause.

Figure 23 - Example of the Status Indicators Flashing during Configuration Mode

IN1 - Indicates that the LOGIC switch is set to 3

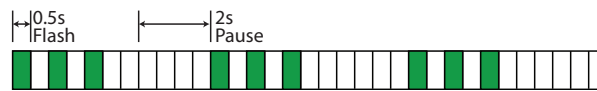

51/L61 - Indicates that the SLS1 switch is set to 4



Logic IN - Indicates that the SLS2/time switch is set to 1

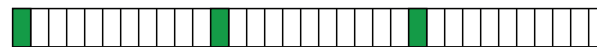

X14/X24 L11 - Indicates the solenoid connection to guard locking switch with OSSD outputs

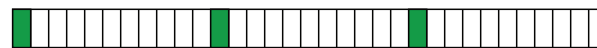

5. Cycle the power to store the settings.

After power-up, the current switch settings are compared to the values in the EEPROM, and the input and output circuits are checked. Upon successful completion of the internal checks, the GLP safety relay is ready for operation.

The X14/X24 L11 status indicator indicates the type of connection that is made to terminals 51 and L61. [Table 5](#) shows the conditions for the X14/X24 L11 status indicator blink rates.

Table 5 - X14/X24/L11 Status Indicator

X14/X24/L11 Status Indicator Blinks	Guard Locking Switch	51	L61
One time	OSSD Guard Locking Switch (for example, TLS-ZR or 440G-LZ)	High side	High side
Two times	Standard Guard Locking Switch (for example, TLS3-GD2)	High side	Low side

Diagnostic Status Indicators and Troubleshooting

The GLP safety relay has five status indicators to provide operating status and diagnostic information.

Status Indicators During Power-up

During power-up, the status indicators turn ON and OFF during their self-check process. The self-check takes about 5 seconds for Status Only Logic and 10 seconds for all other Logic Settings.

Status Indicators During Normal Operation

Table 6 - Normal Operation Status Indicators

Status Indicator	State	Description
PWR/FAULT	Solid Green	Normal operation.
	Blinking Green	On power-up, the gate appears open. Close the gate or verify 24V DC at terminals S12 and S22. If your guard locking devices use mechanical inputs, start configuration from 9.
	Blinking Red	Non-recoverable fault. See Table 7 on page 32 . Correct fault and cycle power.
	Green with Blinking Red	Recoverable fault. See Table 7 on page 32 . Correct fault and press reset.
IN 1	ON	Input circuits at S12 and S22 are closed.
	OFF	Input circuits at S12 and S22 are open.
51/L61	ON	Gate is locked with Logic Setting 1...4. Output is active with Logic Setting 5...8. 51 and L61 are ON with Status Only.
	OFF	Gate is unlocked with Logic Setting 1...4. Output is inactive with Logic Setting 5...8. 51 and L61 are OFF with Status Only.
	Blinking	Timing cycle has started.
LOGIC IN	ON	Logic IN signal at L12 is active.
	OFF	Logic IN signal at L12 is OFF.
X14/X24 L11	ON	L11 is active and X14/X24 are ON. L11 is active and X14/X24/Y32 are ON with Status Only.
	OFF	L11 is OFF and X14/X24 are OFF. L11 is OFF and X14/X24/Y32 are OFF with Status Only.
	Blinking	Waiting for reset signal or timing cycle has started.

Status Indicators During Diagnostics

The flashing of the status indicators indicate diagnostics. The PWR/Fault indicator shows the major fault. The IN1 indicator shows more detail.

The flashing rate pauses and then repeats itself.

IMPORTANT For accurate diagnostics, always start counting after the first pause. The first cycle may not be accurate.

Table 7 - Diagnostic Status Indicators

Power/Status Indicator	Status/Faults
Solid red	An undeclared fault has occurred. Cycle power to clear the fault and return the GLP safety relay to an operational state.
Flashing red one time	The GLP safety relay is in configuration mode. When the Logic Switch is set to 0 or 9 and the power is cycled, the PWR/Fault status indicator blinks at a 1X rate. The GLP safety relay is in configuration mode. Rotate the switches to the desired positions and cycle power.
Green with flashing red two times	The configuration does not agree with the EPROM. One or more of the rotary switches have changed during operation. The GLP safety relay continues to operate, and the switch or switches can be returned to their original position.
Green with flashing red three times	A lock request was made on terminal S44 but the gate remains open. Close the gate (the voltage at terminals S12 and S22 should be 24V DC), press the unlock request, and then press the lock request.
Green with Flashing red four times	Overspeed - the speed exceeded the SLS2/Time setting. Reduce the speed and press Reset.
Green with flashing red five times	Over Safe Speed Limit (SLS1). Reduce the speed.
Green with flashing red six times	Gate appears open when it should be closed and locked. Try reclosing the gate. Check voltage at S12 and S22 – they should be 24V.
Flashing red two times	Upon power-up, one or more of the rotary switch settings do not agree the value that is stored in the EEPROM. Return the switches to their proper settings and cycle power or reconfigure the GLP safety relay.
Flashing red three times	Proximity Position Fault (In Logic Settings 1 . . . 4, both proximity sensors are low).
Flashing red four times	The input at S12 and S22 opened while the safety gate was locked.
Flashing red five times	Logic Link output or L61 fault. Correct the fault and cycle power to the GLP safety relay.
Flashing red six times	S12 or S22 may be open. X14 or X24 fault. Check for short circuit from X14 to X24. Cycle gate. Check voltage at S12 and S22 – they should be 24V. Correct the fault and cycle power to the GLP safety relay.
Flashing red seven times	With a Logic setting of 1 or 2, the proximity sensors detected speed exceeding the SLS1 setting for more than four pulses on each proximity sensor when the GLP outputs (X14/X24/L11/Y32) are OFF. Note: This covers two cases: 1. On power-up, the gate is locked and the outputs are OFF. 2. After pressing unlock, the gate is unlocked and the outputs are OFF. Prevent excessive machine movement or set the SLS1 setting to a higher level.
Flashing red eight times	Proximity Sensor input fault. IN1 flashing 5 times: P12 ON and P22 changing state. IN1 flashing 5 times: P22 ON and P12 changing state. In Rev A 100, IN1 flashes 5 times whether it is P12 or P22. This fault occurs whether the GLP safety outputs are ON or OFF - the output state is irrelevant. In Rev A 202 and later, the IN1 indicator does not flash. Only the PWR/Fault indicator flashes 8 times. Check the proximity sensor connections and sensing distance. Check the voltages at P12 and P22. The voltage is 24V when the proximity sensor is ON and 0V when the proximity sensor is Off. Cycle power after fixing.
Flashing red nine times	S1 or L61 fault. Check the voltages at terminals S1 and L61. They are less than 3V when OFF and greater than 15V when ON.
Flashing red ten times	Overvoltage – The supply voltage exceeded 28V DC. Reduce the power supply to 24V +10/-15% and cycle the power.

Pulse Testing Functions

Introduction to Pulse Testing

The test pulses are used by the GLP safety relay to detect three short-circuit conditions:

- Between the input terminals and +24V
- Between the input terminals and 24V common
- Between the two input terminals.

The outputs have built in redundancy, as shown in [Figure 24](#). A main transistor supplies power to individual transistors for each output terminal. This arrangement provides the redundant output to achieve the Cat. 3 and SIL 2 safety rating.

Figure 24 - Output Transistor Arrangement

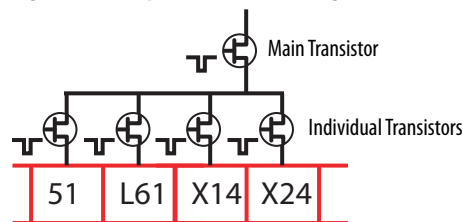

The GLP safety relay continuously tests all transistors. When the main transistor is tested, a 50- μ s pulse appears on all outputs simultaneously. When the individual transistors are tested, the test pulse only appears on their respective terminals.

The main transistor test is predominately 50 μ s but can be as long as 350 μ s. The pulse width on X14, X24, 51, and L61 is between 200...850 μ s.

Figure 25 - Output Pulse Test Width

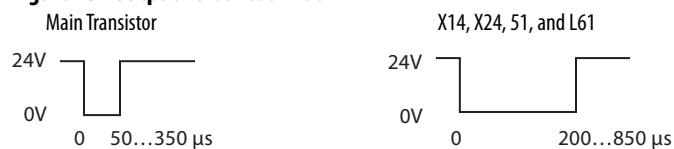

Pulse Testing for Inputs

When configuration starts with Logic Switch setting 9 and goes to a setting from 1 to 4, X14 and X24 terminals generate quick pulses that are used to test for short circuit conditions. This configuration is ideal for guard locking interlocks with mechanical contacts. It is required to achieve a Cat. 4 safety performance rating.

X14 is connected through one mechanical contact to S12 or S22 and X24 is connected through the other mechanical contact to S22 or S12.

- TIP**
- X14 can be connected to S12 or S22
 - X24 can be connected to either S12 or S22

Figure 26 shows a typical sequence of test pulses. The individual transistor tests are interspersed between the main transistor tests.

Figure 26 - Pulse Test Sequence

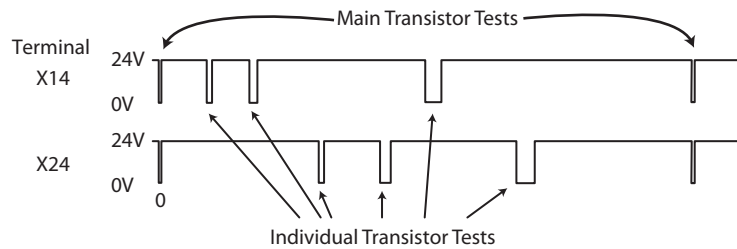

Test of OSSD Outputs

The GLP safety relay does not use pulse testing when X14 and X24 are configured as OSSD outputs. Instead, the GLP safety relay turns the OSSD outputs with a short delay between them. If a cross fault short circuit exists between X14 and X24, the GLP safety relay detects that condition and immediately turn the outputs OFF. Turn OFF occurs in less than 1 ms and the PWR/Fault status indicator flashes red six times.

Figure 27 - OSSD Cross Fault Detection

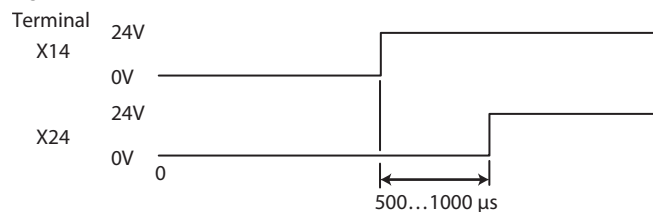

Ethernet Communication

The GLP safety relay is equipped with optical communication via optical link. With the optical link, diagnostic data can be read from the GLP safety relay and transferred to other devices over an EtherNet/IP network.

Figure 28 - Arrangement of EtherNet/IP Network Interface and GSR Relays



The catalog number 440R-ENETR EtherNet/IP network interface must be in the left-most position. The EtherNet/IP network interface automatically determines the models present and their position. Up to six GSR relays can be mounted next to the EtherNet/IP network interface. See publication [440R-UM009](#) for further details on the EtherNet/IP network interface.

Webpage

IMPORTANT The 440R-ENETR Series B module does not have a webpage. The webpage is available with Series A modules only.

The GLP safety relay provides the following data on the EtherNet/IP network interface webpage. To access the webpage, connect an Ethernet cable to your computer and type in the Ethernet address.

Figure 29 - Access the EtherNet/IP Network Interface Webpage

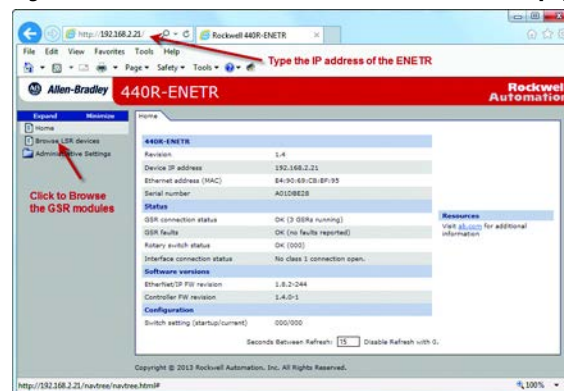

IMPORTANT Using an Ethernet browser to query the 440R-ENETR module is available only with Series A modules.

Series B does not have the browsing capability. When you browse the GSR modules, the GLP safety relay appears as Device Type 8. [Table 8](#) shows the GLP safety relay data that can be viewed from the webpage.

Table 8 - GLP Safety Relay Data On Ethernet Website

Device Type	8
Firmware Revision	32
Running	True
Has Recoverable Fault	False
Has Non-recoverable Fault	False
Operation State 1	4
Operation State 2	152
Recoverable Fault Processor 1	0
Recoverable Fault Processor 2	0
Communication Errors	0
Communication Retries	0
Non-recoverable Error Count	0
Recoverable Error Count	0

Logix AOP

The catalog number 440R-ENETR EtherNet/IP network interface includes the Logix AOP for the GLP safety relay.

[Figure 30](#) shows the variables that are reported back from the GLP safety relay. The variables are all status inputs. In Series A, the AOP calls the position of the relay as a Slot number.

Figure 30 - GLP Safety Relay Logix AOP for 440R-ENETR Series A

Name	Value
ENETR_GLP.i.Slot2_GSR_GLP_S12_S22_Status	0
ENETR_GLP.i.Slot2_GSR_GLP_SingleWireSafetyIn	0
ENETR_GLP.i.Slot2_GSR_GLP_LockRequest_S44	0
ENETR_GLP.i.Slot2_GSR_GLP_UnLockRequest_S54	0
ENETR_GLP.i.Slot2_GSR_GLP_Recoverable_Fault	0
ENETR_GLP.i.Slot2_GSR_GLP_NonRecoverable_Fault	0
ENETR_GLP.i.Slot2_GSR_GLP_S1	1
ENETR_GLP.i.Slot2_GSR_GLP_L61	1
ENETR_GLP.i.Slot2_GSR_GLP_Y32	1
ENETR_GLP.i.Slot2_GSR_GLP_S11	1
ENETR_GLP.i.Slot2_GSR_GLP_S21	1
ENETR_GLP.i.Slot2_GSR_GLP_L11	0
ENETR_GLP.i.Slot2_GSR_GLP_NonRecoverableFault_A	16#00
ENETR_GLP.i.Slot2_GSR_GLP_NonRecoverableFault_B	16#00
ENETR_GLP.i.Slot2_GSR_GLP_GateOpenFault	1
ENETR_GLP.i.Slot2_GSR_GLP_InvalidSwitchSetting	0
ENETR_GLP.i.Slot2_GSR_GLP_LockRequestGateOpenFault	0
ENETR_GLP.i.Slot2_GSR_GLP_Overspeed_SL2	0
ENETR_GLP.i.Slot2_GSR_GLP_Overspeed_SL1	0
ENETR_GLP.i.Slot2_GSR_GLP_LockRequestHeldOn	0
ENETR_GLP.i.Slot2_GSR_GLP_UnLockRequestHeldOn	0

Figure 31 shows the GLP Logix AOP for the 440R-ENETR Series B. The relay position is now shown as Relay n , where n is the position of the relay with respect to the 440R-ENETR module.

Figure 31 - GLP Safety Relay Logix AOP for 440R-ENETR Series B

ENETR_B591.Relay2_GSR_GLP	(...) AB.GSR_GLP_V210
-ENETR_B591.Relay2_GSR_GLP.GateOpenFault	0 BOOL
-ENETR_B591.Relay2_GSR_GLP.InvalidSwitchSetting	0 BOOL
-ENETR_B591.Relay2_GSR_GLP.L11	0 BOOL
-ENETR_B591.Relay2_GSR_GLP.L161	0 BOOL
-ENETR_B591.Relay2_GSR_GLP.LockRequest_544	0 BOOL
-ENETR_B591.Relay2_GSR_GLP.LockRequestGateUserFault	0 BOOL
-ENETR_B591.Relay2_GSR_GLP.LockRequestHoldIn	0 BOOL
-ENETR_B591.Relay2_GSR_GLP.NonRecoverable_Fault	0 BOOL
+ENETR_B591.Relay2_GSR_GLP.NonRecoverableFault_A	16#00 SINT
+ENETR_B591.Relay2_GSR_GLP.NonRecoverableFault_B	16#00 SINT
-ENETR_B591.Relay2_GSR_GLP.OS50_51	0 BOOL
-ENETR_B591.Relay2_GSR_GLP.Overspeed_SL1	0 BOOL
-ENETR_B591.Relay2_GSR_GLP.Overspeed_SL2	0 BOOL
-ENETR_B591.Relay2_GSR_GLP.Recoverable_Fault	0 BOOL
-ENETR_B591.Relay2_GSR_GLP.S11	0 BOOL
-ENETR_B591.Relay2_GSR_GLP.S12_S22_Status	1 BOOL
-ENETR_B591.Relay2_GSR_GLP.S21	0 BOOL
-ENETR_B591.Relay2_GSR_GLP.SingleWireSafetyIn	0 BOOL
-ENETR_B591.Relay2_GSR_GLP.UnlockRequest_S54	0 BOOL
-ENETR_B591.Relay2_GSR_GLP.UnlockRequestHoldIn	0 BOOL
-ENETR_B591.Relay2_GSR_GLP.Y32	0 BOOL
-ENETR_B591.Relay2.Connected	1 BOOL

Notes:

Proximity Sensors and Targets

Proximity Sensor Selection

The GLP safety relay accepts proximity sensors that meet the following requirements:

1. 24V DC powered
2. 3-wire (Power, Ground, and Signal)
3. PNP Output Type
4. Leakage current less than 1 mA.

The GLP safety relay does not require the use of safety-rated proximity sensors. Redundant standard-rated industrial sensors are sufficient to meet the safety ratings of the GLP safety relay.

Proximity Sensor Targets

The sensors must be mounted no further than 0.8 times their nominal sensing distance. To achieve maximum speed, the sensors must be mounted at 0.5 times their nominal sensing distance. The depth of the gear space must be at least three times the nominal sensing distance.

The proximity sensors have the following requirements:

1. The space must be at least twice the diameter of the proximity sensors.
2. The mark (target) must be at least four times the diameter of the proximity sensor.
3. The detection of the targets must be alternating.
4. With logic settings 1...4, both sensors cannot be off simultaneously. With logic settings 5...8, both sensors can be off simultaneously, but the recommended arrangement is to mount the sensors so that both sensors are not off simultaneously.
5. Due to the overspeed detection time, speed limits must be set lower than the maximum allowable speed limit.



ATTENTION: To avoid a single common cause failure to danger, the proximity sensors must be mounted on independent hardware brackets and fixtures when logic settings 5...8 are used.

Figure 32 - Proximity Mark (Space Dimensions)

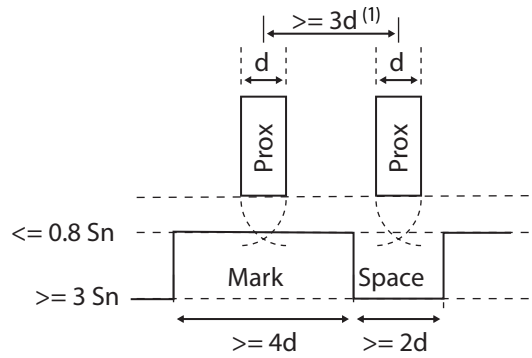

(1) The spacing distance depends on the type of proximity sensor. Verify the requirements of your proximity sensor.

Figure 33 - Target Wheel Example 1

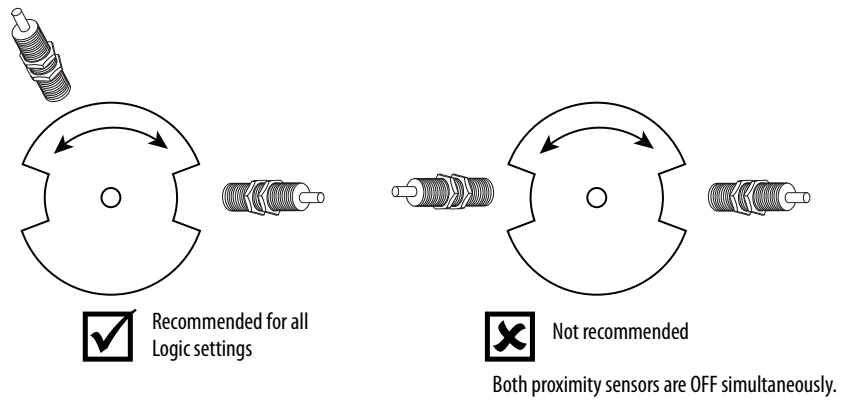
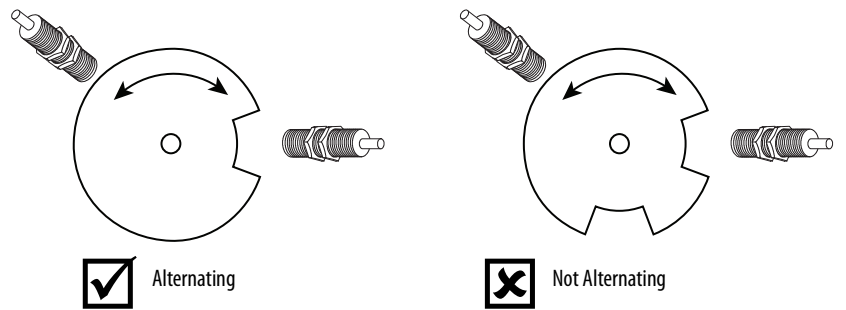

Figure 34 - Target Wheel Example 2



Targets do not necessarily have to be gear tooth. [Figure 35](#) shows an example of a wheel with holes. The hole is equivalent to a space and the wheel is the mark.

Figure 35 - Target Wheel Example 3

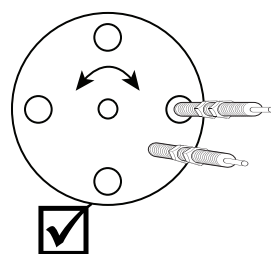
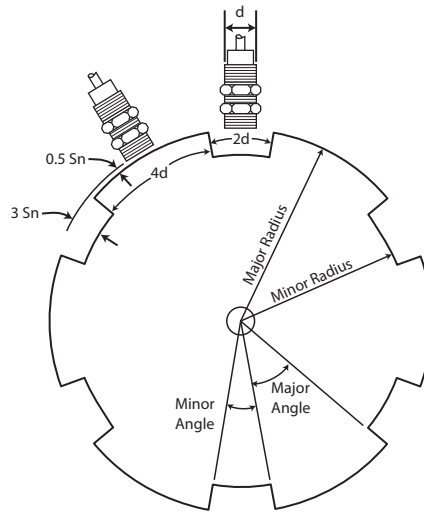

Figure 36 shows a target wheel that is configured to achieve the maximum resolution.

Figure 36 - Maximum Resolution



The spreadsheet in Figure 37 can be used to calculate the target wheel dimensions to achieve the maximum resolution. The example shows a 12 mm (0.47 in.) proximity sensor with a 3 mm (0.12 in.) nominal sensing range.

Figure 37 - Target Wheel Dimension Calculation

	A	B	C	D	E	F	G	H
1	Prox Diameter d	12	mm					
2	Nominal Sensing Range	3	mm					
3								
4	Number of Targets	Space (mm)	Mark (mm)	Circumference (mm)	Major Radius (mm)	Minor Radius (mm)	Major Angle (°)	Minor Angle (°)
5	1	24	48	72	11.5	4	240	120
6	2	48	96	144	22.9	15.4	120	60
7	3	72	144	216	34.4	26.9	80	40
8	4	96	192	288	45.8	38.3	60	30
9	5	120	240	360	57.3	49.8	48	24
10	6	144	288	432	68.8	61.3	40	20
11	7	168	336	504	80.2	72.7	34.3	17.1
12	8	192	384	576	91.7	84.2	30	15
13	9	216	432	648	103.1	95.6	26.7	13.3
14	10	240	480	720	114.6	107.1	24	12
15								
16	Column	Formula in Row 11						
17	B	Sum of Target Spaces = 2 * \$B\$1 * A11						
18	C	Sum of Target Marks = 4 * \$B\$1 * A11						
19	D	Circumference = E11 + C11						
20	E	Major Radius = D11 / 2 / 3.141						
21	F	Minor Radius = E11 - (3 * \$B\$2) + (0.5 *						
22	G	Major Angle = 360 / A11 / 1.5						
23	H	Minor Angle = 360 / A11 / 3						

In the formulas in Figure 37, the '\$' indicates that the column or row is absolute and not relative to its current location. For example, "\$B\$1" always refers to column B row 1 when you copy the formula to another cell.

Notes:

Example Operational Sequence Diagrams

This chapter provides operational sequence diagrams of typical GLP applications. The purpose of provide you with a better insight of some of the performance characteristics of the GLP safety relay.

Stop Cat 1 Example

This example shows a typical application where the GLP safety relay is used in a Stop Category 1 application.

Example Schematic

In this example, we have a GLP safety relay that controls a 440G-LZ Power to Release guard locking interlock, drives a PowerFlex® 525 AC drive, and is connected to an EM expansion safety relay.

The Y32 output is directly connected to the Start and Stop terminals of the PF525 drive. When Y32 goes HI, the PF525 drive can be started. When Y32 goes LO, the drive executes its pre-configured stop function.

In this example, the 440G-LZ guard locking switch can easily replace by the TLS-ZR guard locking switch.

Figure 38 - Schematic for Stop Cat 1 Example

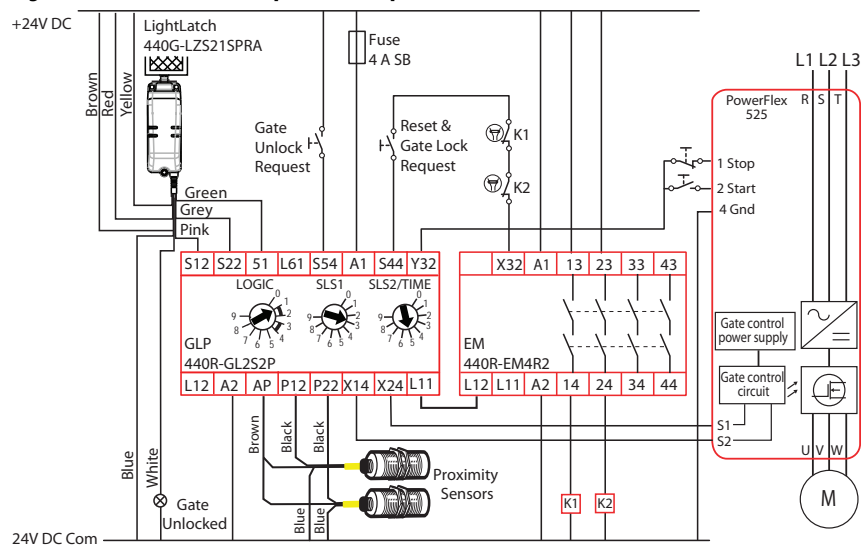

Sequence Diagram

Figure 39 shows the sequence of operations. This diagram assumes that all components are operating properly and no faults are present.

Figure 39 - Operational Sequence for Stop Cat 1 Example

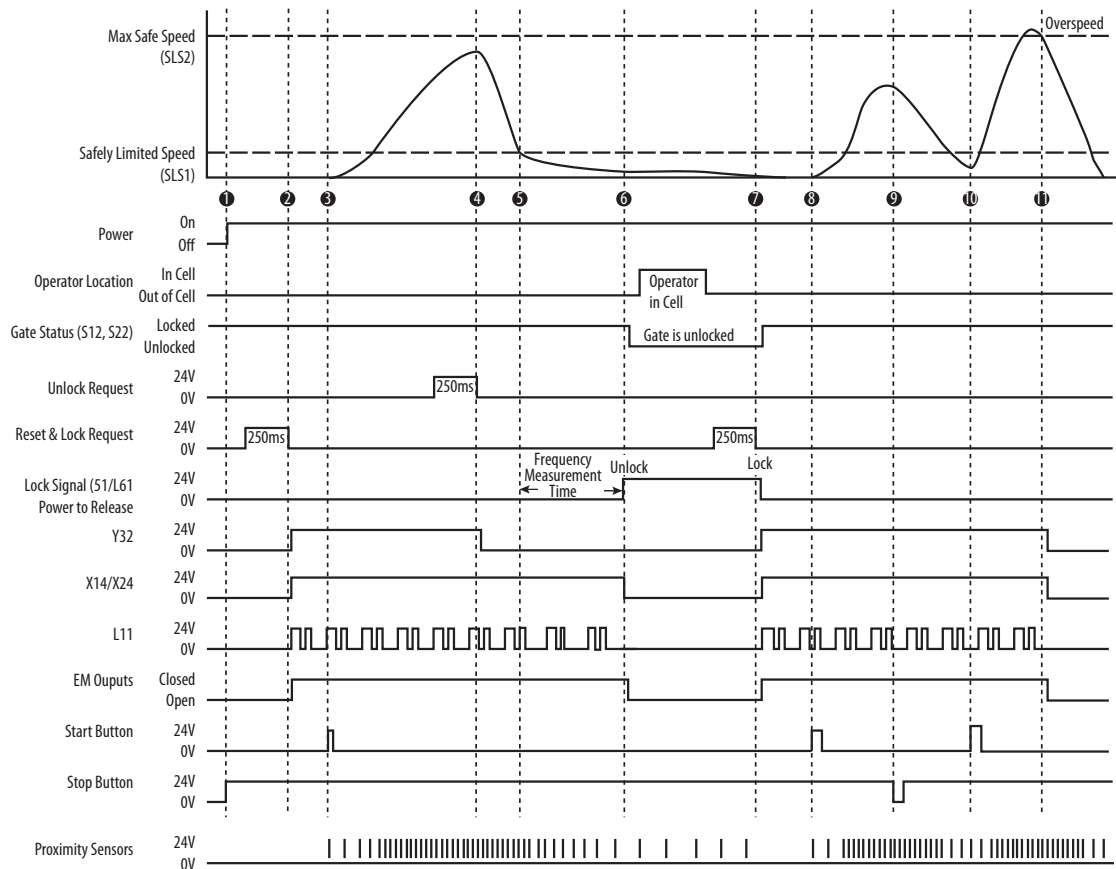

Sequence Steps

The following steps describe each of the highlighted points in Figure 39.

1. 24V DC power is applied to the safety system. Because the gate is closed, the 440G guard locking switch has locked the gate. With the gate closed and locked, the GLP safety relay is ready for reset.
2. You press and release the Reset button (hold for 250...3000 ms). The Y32 goes HI, which allows the PF525 drive to start after the Start button is pressed.

Terminals X14 and X24 go HI, which enables the Safe Torque Off function of the PF525 drive.

The single wire safety output at L11 starts oscillating. The EM expansion relay energizes and turns on contactors K1 and K2.

3. You press the Start button and the motor begins to accelerate and the proximity sensors generate pulses. At some point, the speed becomes faster than the safely limited speed set by SLS1 on the GLP safety relay but stays below the maximum safe speed. This speed is the normal machine operating speed during production.
4. Later, you want to enter the cell. You press the Unlock Request button. Upon release, the signal at Y32 goes to zero, which is a Stop signal for the drive. The drive is configured to execute an orderly shutdown and ramps the speed of the motor to zero. The pulses from the proximity sensors reduce in frequency.
5. When the motor speed is slower than the configured Safely Limited Speed, the GLP safety relay begins the Frequency Measurement Time to verify that the motor speed remains below the SLS1 setting.
6. At the end of the frequency Measurement Time, the gate terminal 51 output turns ON to unlock the gate (the 51/L61 indicator turns OFF). Simultaneously, the L11 signal stops oscillating. This action causes the EM outputs to open which de-energizes K1 and K2.

IMPORTANT The motor can still be rotating slowly. The slowest rate must not cause harm to the operator.

Now you can open the gate, enter the manufacturing cell, and perform normal production operations as specified in your procedures. You leave the cell and close the gate.

7. You press and release the Reset button. The lock command signal (terminal 51) goes low to lock the gate. The GLP safety relay interrogates S12 and S22. If the gate is locked, the GLP safety relay sets Y32, X14 and X24 high, and L11 begins oscillating.
8. You press the Start button. The motor ramps up to production speed.
9. You press the Stop button. The motor decelerates to a stop. When the speed drops below the safely limited speed, the GLP safety relay does not change the door status.
10. You press the Start button. The motor ramps up to production speed.
11. The motor exceeds the maximum speed set by SLS2. The GLP safety relay detects the speed by the proximity sensors and immediately turns off Y32, X14 and X24, and L11 stops oscillating. The drive executes a coast-to-stop. The safety gate remains locked. The PWR/Fault status indicator is green with 4x flashing red to indicate overspeed.

SLS Example

This example shows a typical application where the GLP safety relay is used in a Stop Category 1 application.

Example Schematic

In this example, we have a GLP safety relay that controls a 440G-LZ Power to Release guard locking interlock, drives a PowerFlex 525 AC drive, and is connected to an EM expansion safety relay.

The Y32 output is directly connected to terminal 5 of the PF525 drive, which is configured to be set to a Preset Frequency. When Y32 goes HI, the PF525 drive immediately sets the motor to run at the predetermined speed.

In this example, the 440G-LZ guard locking switch can easily replace by the TLS-ZR guard locking switch.

Figure 40 - Schematic for Safely Limited Speed Example

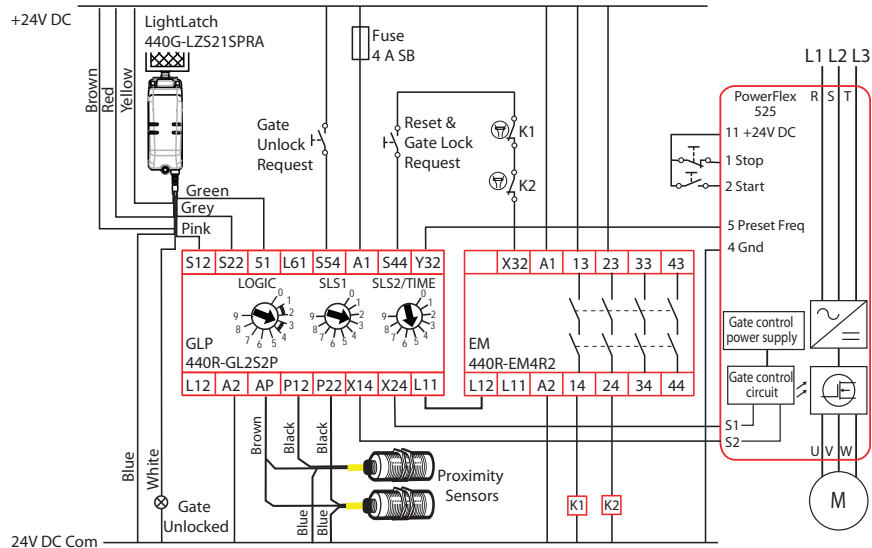

Sequence Diagram

Figure 41 shows the sequence of operations. This diagram assumes that all components are operating properly and no faults are present.

Figure 41 - Operational Sequence for Safely Limited Speed Example

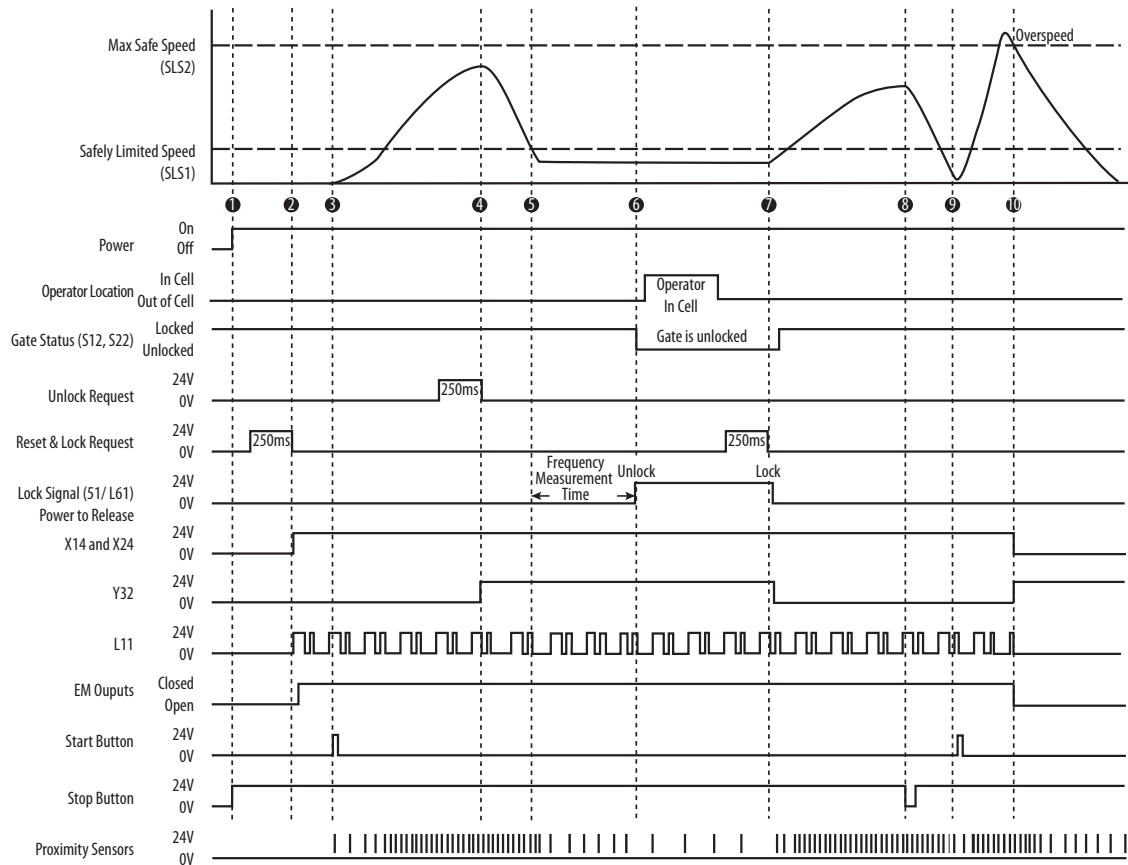

Sequence Steps

The following steps describe each of the highlighted points in Figure 41.

1. 24V DC power is applied to the safety system.
Because the gate is closed, the 440G guard locking switch has locked the gate. With the gate closed and locked, the GLP safety relay is ready for reset.
2. You press and release the Reset button (hold for 250...3000 ms).
Terminals X14 and X24 go HI, which enables the Safe Torque Off function of the PowerFlex 525 drive.
The single wire safety output at L11 starts oscillating. The EM expansion relay energizes and turns on contactors K1 and K2.

3. You press the Start button and the motor begins to accelerate and the proximity sensors generate pulses. At some point, the speed becomes faster than the safely limited speed set by SW2 on the GLP safety relay, but stays below the maximum safe speed. This speed is the normal machine operating speed during production.
4. Later, you want to enter the cell. You press the Unlock Request button. Upon release of the button:
 - The signal at Y32 goes HI, which commands the PowerFlex 525 drive to go to its preconfigured safe slow speed.
 - The 51/L61 indicator on the GLP safety relay starts blinking, waiting for the speed to reduce below the safely limited speed.
5. The pulses from the proximity sensors reduce in frequency. When they indicate that the speed is below the safely limited speed, the GLP safety relay begins the Frequency Measurement Time to verify that the speed is maintained below the SLS1 setting. The motor continues turning at the safe speed.
6. At the end of the Frequency Measurement Time, the gate terminal 51 output turns ON to unlock the gate (the 51/L61 indicator turns OFF). The motor continues turning at the safe speed. You enter the manufacturing cell, perform the required production functions, and then leave the cell.
7. You press and release the Reset and Lock Request. Upon release of the button:
 - The Lock signal (terminal 51) goes LO (the 51/L61 indicator turns ON).
 - The Gate Status signal (S12/S22) goes HI, which indicates that the door is closed and locked.
 - The Y32 signal then goes LO and the PowerFlex 525 drive ramps up to normal production speeds.
8. During the normal production process, you press the Stop button. The motor decelerates to a stop. When the speed drops below the maximum safe slow speed, the GLP safety relay does not change the door status.
9. You press the Start button. The motor ramps up to production speed.
10. The motor exceeds the maximum speed set by SLS2 (a fault condition). The GLP safety relay detects the speed by the proximity sensors and immediately turns the X14/X24 outputs and L11 stops oscillating. The EM outputs turn off and the PowerFlex 525 drive executes a coast-to-stop. Terminal Y32 goes HI and the safety gate remains locked. The PWR/Fault indicator is green with 4x flashing red to indicate overspeed.

Delayed Unlock with Auto Reset Example

This example can be used for Logic setting 5...8 when configuration is started from 0.

Example Schematic

In this example, we have a GLP safety relay with an EM expansion module. This arrangement operates similar to the Guardmaster CU2 relay; the outputs turn ON when the motion is below the threshold set by the SLS1 rotary switch.

Figure 42 - Schematic for Delayed Unlock with Auto Reset

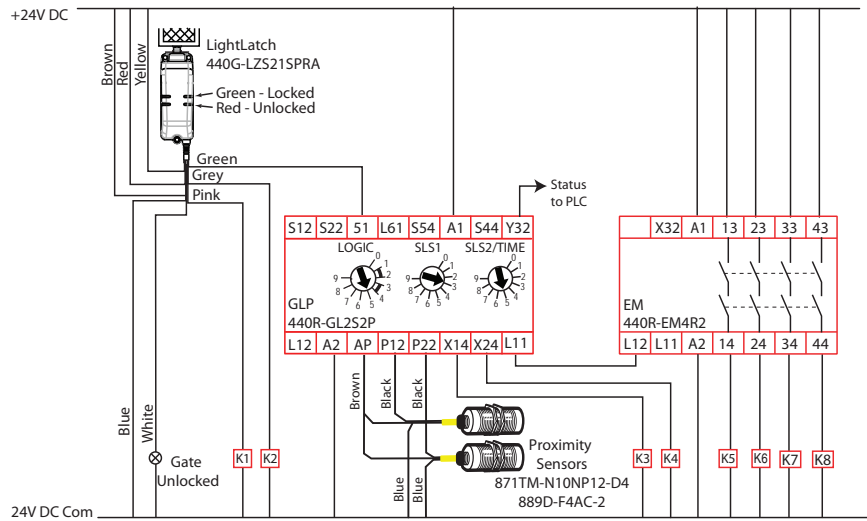

Sequence Diagram

Figure 43 shows the sequence of operations. This diagram assumes that all components are operating properly and no faults are present.

Figure 43 - Operational Sequence for Delayed Unlock with Auto Reset

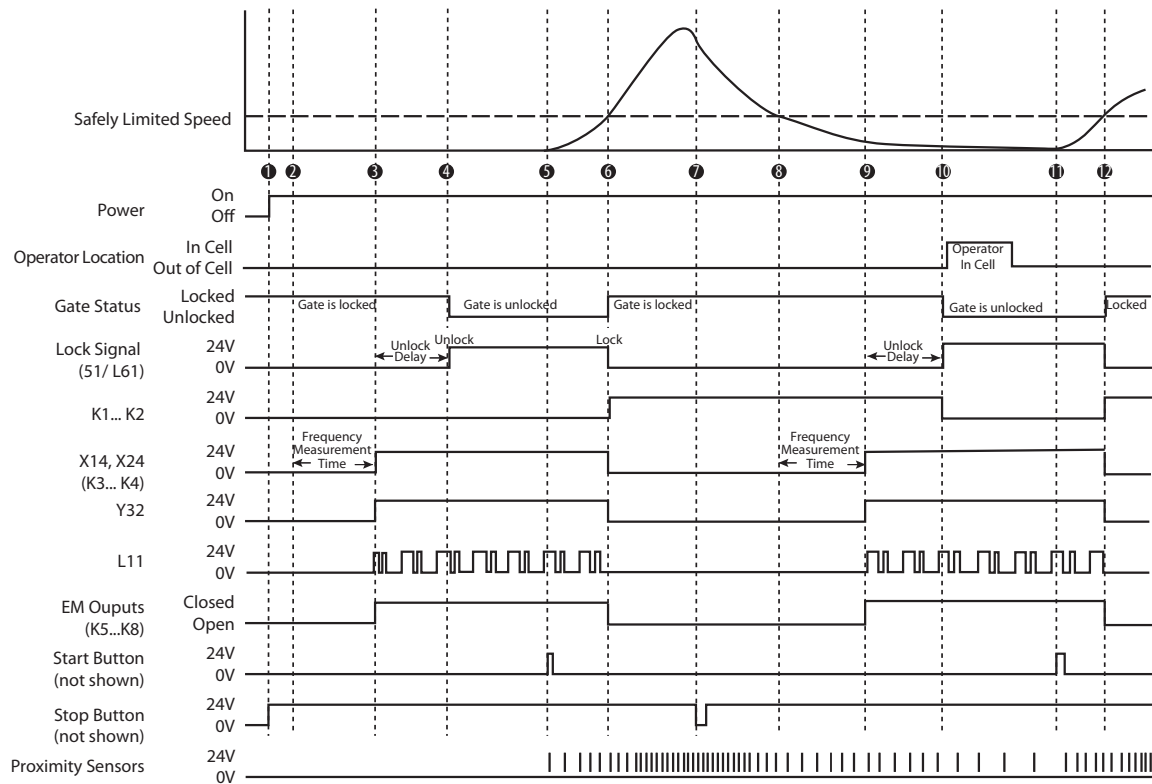

Sequence Steps

The following steps describe each of the highlighted points in Figure 43.

1. 24V DC power is applied to the safety system. The safety devices perform their internal tests.
2. The GLP safety relay begins its Frequency Measurement Time to check the proximity sensor speed.
3. After the GLP safety relay determines the speed is below the SLS2 setting, the X14/X24/L11 outputs turn ON and the unlock delay timer starts. If the proximity sensor speed is greater than SLS1 upon power-up, the GLP safety relay keeps the gate locked and maintains its outputs in the OFF state.
4. The 51/L61 outputs turn ON and unlock the gate.
5. You press the Start button. The machine begins to accelerate and the proximity sensors generate pulses.

6. Then, the speed becomes faster than the safely limited speed set by SLS1 on the GLP safety relay. The GLP safety relay issues a lock command and turns off its outputs (X14/X24/L11/Y32). The gate switch outputs turn ON and energize K1 and K2. This speed is the normal machine operating speed during production.
7. Later, you want to enter the cell. You press the Stop button and the machine begins to decelerate.
8. When the speed of the machine decelerates below the safely limited speed, the GLP safety relay begins its Frequency Measurement Timer to help verify that the machine is consistently below the SLS1 setting.
9. The GLP safety relay turns its outputs (X14/X24/L11/Y32) ON and starts the unlock delay time. The combination of the Logic and SLS2/Time settings set the unlock delay time.
10. At the end of the unlock delay time, the GLP safety relay unlocks the gate, which allows you into the cell. After completing the production operations, you leave the cell and close the gate.
11. You press the Start button to begin production operations.
12. When the speed of the machine reaches the SLS1 setting, the GLP locks the gate and turns its outputs OFF.

Status Only Example

This example only applies for Logic setting 8, when the configuration process starts from 9. The GLP safety relay does not perform any guard locking or resetting.

Example Schematic

Figure 44 shows the outputs that turn ON based on the speed the proximity sensors detect. When the speed exceeds SLS1, the 51/61 outputs turn ON. When the speed exceeds SLS2, the remaining outputs turn ON; that is, all outputs are ON, when the speed exceeds SLS2.

Figure 44 - Schematic for Status Only

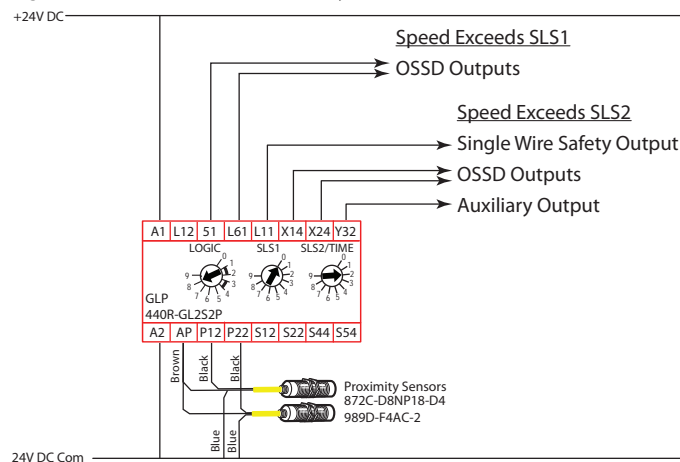

Sequence Diagram

[Figure 45](#) the sequence of operations. This diagram assumes that all components are operating properly and no faults are present.

Figure 45 - Operational Sequence for Status Only Example

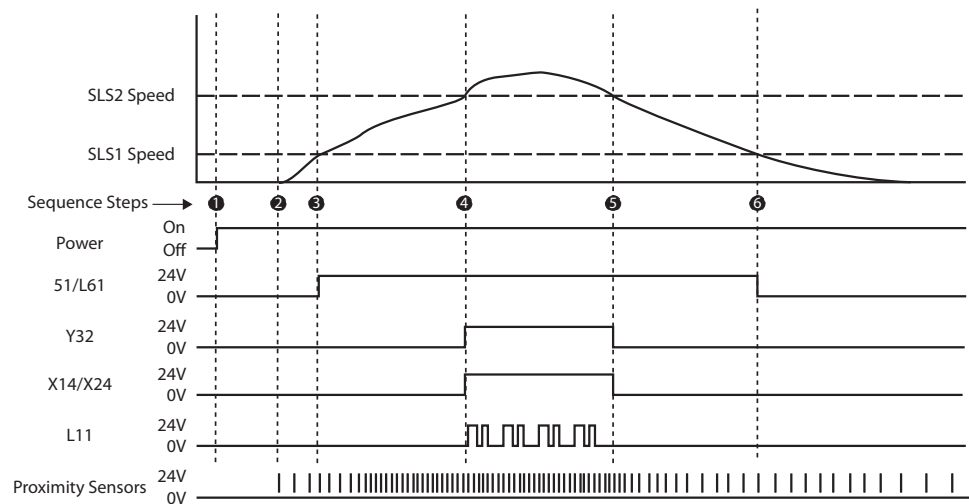

Sequence Steps

The following steps describe each of the highlighted points in [Figure 45](#).

1. 24V DC power is applied to the safety system. The safety devices perform their internal tests.
2. Because the proximity sensors do not detect any motion, the GLP safety relay maintains all of its outputs in the OFF state. The proximity sensors detect and increase in the speed of the machine.
3. When the speed increases past the SLS1 setting, the 51/L61 outputs turn ON.
4. When the speed increases past the SLS2 setting, the GLP safety relay turns on the remaining outputs (X14/X24/L11 and Y32).
5. When the speed decreases below SLS2, the GLP safety relay turns X14/X24/L11 and Y32 OFF.
6. When the speed decreases below SLS1, the GLP safety relay turns 51/L61 OFF.

Specifications

General Specifications

Table 9 - General Specifications

Attribute	440R-GL2S2P
Dimensions, WxHxD	22.5 x 119.14 x 113.6 mm (0.88 x 4.69 x 4.47 in.)
Shipping weight, approx.	150 g (0.33 lb)
Wire size	0.2...2.5 mm ² (24...14 AWG)
Wiring category	Copper that withstands 75 °C (167 °F)
Terminal screw torque	0.4 N-m (4 lb-in)
Power supply voltage range	24V DC PELV/SELV 0.85...1.1 x rated voltage
Power consumption	2 W
Fuse	4 A, slow blow (slow release)
Case material	Polyamide PA 6.6
Terminal protection	IP20
Enclosure protection	IP40 (NEMA 1)

Environmental Specifications

Table 10 - Environmental Specifications

Attribute	440R-GL2S2P
Temperature, operating	-5...+55 °C (23...131 °F)
Relative humidity	90%
Vibration	10...55 Hz, 0.35 mm
Shock	10 g, 16 ms
Pollution level	2

Input IN1

Table 11 - Inputs IN1

Attribute	440R-GL2S2P
Input signals	S12, S22
ON voltage, max	26.4V
ON voltage, min	11V
OFF voltage, max	5V
OFF current, max	2 mA
ON current at 24V DC, max	11.0 mA
ON current at 26.4V DC, max	11.1 mA
Galvanic isolation: I/O from logic	No
Overvoltage protection	Yes
Test out pulse duration	≤850 μs
Test out pulse period	17 ms
Off pulse accepted for OSSD setting without declaring the input as OFF	Min = 0 μs Max = 850 μs
Reverse voltage protection	Yes
Input capacitance	10 nF

Proximity Sensor Signals

Table 12 - Proximity Sensor Signals

Attribute	440R-GL2S2P
Input signals	P12, P22
ON voltage, max	26.4V
ON voltage, min	6V
OFF voltage, max	5V
OFF current, max	2 mA
ON current at 24V DC, max	6.5 mA
Hole pulse time (low pulse), min	40 μs
Pulse Resolution, max	4 kHz
Galvanic isolation: I/O from logic	No
Input capacitance	1 nF
Overvoltage protection	Yes

Lock Unlock Request

Table 13 - Lock Unlock Request

Attribute	440R-GL2S2P
Input signals	S44, S54
ON voltage, max	26.4V
ON voltage, min	11V
OFF voltage, max	5V
OFF current, max	2 mA
ON current at 24V DC, max	11.0 mA
ON current at 26.4V DC, max	11.1 mA
Galvanic isolation: I/O from logic	No
Overvoltage protection	Yes
Input capacitance	10 nF
Duration	0.5...3.0 s

Lock Unlock Signals

Table 14 - Lock Unlock Signals

Attribute	440R-GL2S2P
Output signals	51 & L62
Continuous output current, max	0.300 A
High side voltage, max	26.4V
High side voltage, min	15V
Low side voltage, max	3V
Surge output current, max	3 A
Surge output current duration, max	10 μ s
Load capacitance, max	1 μ F
OFF state leakage current, max	< 0.1 mA
Short-circuit detection	Yes
Short-circuit protection	Yes

Auxiliary Signal

Table 15 - Auxiliary Signal

Attribute	440R-GL2S2P
Output signals	Y32
Continuous output current, max	50 mA
ON state voltage drop (P/S to +), max	0.2V
Surge output current, max	700 mA
Surge output current duration, max	5 ms
Load capacitance, max	1 µF
OFF state leakage current, max	< 0.1 mA
Short-circuit detection	No
Short-circuit protection	Yes
Galvanic isolation: I/O from logic	No

Single Wire Safety Input Signal

Table 16 - Single Wire Safety Input Signal

Attribute	440R-GL2S2P
Input signals	L12
ON voltage, max	26.4V
ON voltage, min	11V
OFF voltage, max	5V
OFF current, max	2 mA
ON current at 24V DC, max	11.0 mA
ON current at 26.4V DC, max	11.1 mA
Galvanic isolation: I/O from logic	No
Overvoltage protection	Yes
Reverse voltage protection	Yes
Input capacitance	10 nF

Single Wire Safety Output Signal

Table 17 - Single Wire Safety Output Signal

Attribute	440R-GL2S2P
Output signals	L11
Continuous output current, max	50 mA
ON state voltage drop (P/S to +), max	0.2V
Surge output current, max	700 mA
Surge output current duration, max	5 ms
Load capacitance, max	1 μ F
OFF state leakage current, max	< 0.1 mA
Short-circuit detection	No
Short-circuit protection	Yes
Galvanic isolation: I/O from logic	No
Fanout (# connections to L11, max)	10
Cable length between L11 and L12	30 m (98.4 ft)

Safety/Pulse Test Outputs

Table 18 - Safety/Pulse Test Outputs

Attribute	440R-GL2S2P
Output signals	X14, X24
Continuous output current, max	0.5 A
Surge output current, max	1.5 A
Surge output current duration, max	5 ms
Residual voltage (drop from P/S), max	0.2V
Load capacitance, max	1 μ F
OFF state leakage current, max	< 0.1 mA
Short-circuit protection	Yes
Reverse voltage protection	Yes (with external fuse required)
Aggregate current of outputs per module, max	1.8 A
Galvanic isolation: I/O from logic	No
Pulse test duration	\leq 850 μ s
Pulse test period	\leq 13000 ms (<15 s)

Response Times

Table 19 - Response Times

	Logic 1...4		Logic 5...8	Status Only	
	X14, X24, L11	Cat 1 Y32	X14, X24, L11, Y32	51, L61	X14, X24, L11, Y32
Unlock request (S54)	See SLS1 Frequency Measuring Time (page 28)	27 ms	—	—	—
Single wire safety input, L12		53 ms			
Safety inputs (S12, S22)	53 ms				
Proximity frequency exceeds SLS1	—		345 ms	—	—
Proximity frequency drops below SLS1			—	2.6 s	—
Proximity frequency drops below SLS2			—	—	250 ms

Regulatory Approvals

Agency Certifications

- UL Listed Industrial Control Equipment, certified for US and Canada.
- CE marked for all applicable directives
- C-Tick marked for all applicable acts
- CCC Mark
- S-Mark

Compliance to European Union Directives

This product has the CE marking and is approved for installation within the European Union and EEA regions. It has been designed and tested to meet the following directives.

Machine Safety Directive

This product is designed and tested to meet the European Council Directive 2006/42/EC on machinery and the following standards.

- IEC/EN 61508 — Functional safety of electrical/electronic/programmable electronic safety-related systems
- IEC/EN 62061 — Safety of machinery — Functional safety of safety-related electrical, electronic, and programmable electronic control systems
- EN ISO 13849-1 — Safety of machinery — Safety-related parts of control systems — Part 1: General principles for design

This product is intended for use in an industrial environment.

The performance of the safety function is dependent on the structure of all devices that comprise the safety function. The following two tables provide the data that must be used to represent the GLP safety relay when calculating the safety integrity level (SIL) or the Performance Level (PL).

SIL Rating

The GLP safety relay meets the requirements of SIL CL 2 in accordance with IEC/EN 61508 and IEC 62061.

Table 20 - SIL Rating

Attribute	440R-GL2S2P
Safety Integrity Level Claim Limit	2
PFD	4.13E-09
PFH	7.19E-9
Mode of Operation	High Demand
Hardware Fault Tolerance	1
Safe Failure Fraction	98.95%

Performance Level/Category

The GLP safety relay can be used in safety systems that meet up to Category 3 and Performance Level PLd in accordance with ISO 13849-1.

Table 21 - Performance Level

Attribute	440R-GL2S2P
Category	Up to 3
Performance Level	Up to d
MTTFd	378
DC Avg	97.66%
Mission Time (a)	20
Days Of Operation (d)	365
Hours of Operation (h)	24
T cycle (h/s)	8/28.8

EMC Directive

This product is designed and tested to meet the European Council Directive 2015/30/EU on Electromagnetic Compatibility (EMC) and the following standards:

- EN 61000-6-4: Generic Standards — Emission Standard for Industrial Environments
- EN 61000-6-2: Generic Standards — Immunity for Industrial Environments

This product is intended for use in an industrial environment.

Numerics

440G-LZ
 connection 23

A

agency certifications 59
AOP
 Logix 36
approvals
 regulatory 59
assignments
 terminal 18
auxiliary signal
 specifications 56

C

category
 performance 60
certifications
 agency 59
communication
 Ethernet 35
compliance 59
 European Union directives 59
configuration 27
 process 29
connect
 power supply 19
connection
 440G-LZ 23
 guard locking 20
 MAB 23
 proximity sensor 20
 TLS3-GD2 23
 TLS-Z 23
consideration
 enclosure 14
controller
 ground 19

D

delayed unlock with auto reset
 example 49
 schematic 49
 sequence diagram 50
 sequence steps 50
devices
 mechanical contacts 20
diagnostic
 status indicators 31, 32
diagram
 operational sequence 43
dimensions
 mount 13
DIN rail
 mount 13
 removal 13
directive
 EMC 60
 machine safety 59

E

EMC directive 60
enclosure
 consideration 14
environmental
 specifications 53
Ethernet
 communication 35
European Union directives 59
example
 delayed unlock with auto reset 49
 SLS 46
 status only 51
 stop Cat 1 43
excessive heat
 prevent 15

F

features
 hardware 9
functions
 logic 10
 pulse testing 33

G

general
 specifications 53
ground 17
 controller 19
guard locking
 connection 20
 no 25
 power to lock 24

H**hardware**

features 9

heat 15**I****input**

IN1 specifications 54

lock and reset request 22

pulse testing 34

unlock request 21

input signal

single wire safety specifications 56

installation 13**introduction**

pulse testing 33

L**level**

performance 60

lock

outputs 23

signals 22

lock and reset request

input 22

lock unlock request

specifications 55

lock unlock signal

specifications 55

logic

functions 10

setting 1 10

setting 2 10

setting 3 11

setting 4 11

setting 5...8 12

setting 8 12

switch setting 27

Logix

AOP 36

M**MAB**

connection 23

machine safety directive 59**mechanical contacts**

devices 20

mount

dimensions 13

DIN rail 13

N**no**

guard locking 25

normal operation

status indicators 31

O**operational sequence**

diagram 43

OSSD outputs

safety devices 21

test 34

output signal

single wire safety specifications 57

outputs

lock 23

OSSD test 34

safety 25

overview 9**P****performance level/category** 60**power** 17**power supply**

connect 19

power to lock

guard locking 24

power-up

status indicators 31

prevent

excessive heat 15

prevent excessive 15**process**

configuration 29

proximity sensor

connection 20

selection 39

signal specifications 54

targets 39

pulse testing

functions 33

input 34

introduction 33

R**recommendation**

wire 17

regulatory approvals 59**removable**

terminal 14

removal 14

DIN rail 13

requirements

wire 17

response times

specifications 58

S

safety
 outputs 25
 single wire 26

safety devices
 OSSD outputs 21

safety/pulse test outputs
 specifications 57

schematic
 delayed unlock with auto reset 49
 SLS 46
 status only 51
 stop Cat 1 43

selection
 proximity sensor 39

sequence diagram
 delayed unlock with auto reset 50
 SLS 47
 status only 52
 stop Cat 1 44

sequence steps
 delayed unlock with auto reset 50
 SLS 47
 status only 52
 stop Cat 1 44

setting
 logic switch 27
 SLS1 switch 28
 SLS2 switch 28
 time switch 28

signals
 lock 22
 unlock 22

SIL rating 60

single wire safety 26
 input signal specifications 56
 output signal specifications 57

SLS
 example 46
 schematic 46
 sequence diagram 47
 sequence steps 47

SLS1 switch
 setting 28

SLS2 switch
 setting 28

spacing 14

specifications 53
 auxiliary signal 56
 environmental 53
 general 53
 input IN1 54
 lock unlock request 55
 lock unlock signal 55
 proximity sensor signal 54
 response times 58
 safety/pulse test outputs 57
 single wire safety input signal 56
 single wire safety output signal 57

status indicators
 diagnostic 31, 32
 normal operation 31
 power-up 31

status only
 example 51
 schematic 51
 sequence diagram 52
 sequence steps 52

stop Cat 1
 example 43
 schematic 43
 sequence diagram 44
 sequence steps 44

SWS 26

T

targets
 proximity sensor 39

terminal
 assignments 18
 removable 14
 torque 17

test
 OSSD outputs 34

time switch
 setting 28

TLS3-GD2
 connection 23

TLS-Z
 connection 23

torque
 terminal 17

troubleshooting 31

U

unlock
 signals 22

unlock request
 input 21

W

web page 35

wire 17
 recommendation 17
 requirements 17
 size 17

Notes:

Rockwell Automation Support

Use the following resources to access support information.

Technical Support Center	Knowledgebase Articles, How-to Videos, FAQs, Chat, User Forums, and Product Notification Updates.	https://rockwellautomation.custhelp.com/
Local Technical Support Phone Numbers	Locate the phone number for your country.	http://www.rockwellautomation.com/global/support/get-support-now.page
Direct Dial Codes	Find the Direct Dial Code for your product. Use the code to route your call directly to a technical support engineer.	http://www.rockwellautomation.com/global/support/direct-dial.page
Literature Library	Installation Instructions, Manuals, Brochures, and Technical Data.	http://www.rockwellautomation.com/global/literature-library/overview.page
Product Compatibility and Download Center (PCDC)	Get help determining how products interact, check features and capabilities, and find associated firmware.	http://www.rockwellautomation.com/global/support/pcdc.page

Documentation Feedback

Your comments will help us serve your documentation needs better. If you have any suggestions on how to improve this document, complete the How Are We Doing? form at http://literature.rockwellautomation.com/idc/groups/literature/documents/du/ra-du002_-en-e.pdf.

Rockwell Automation maintains current product environmental information on its website at <http://www.rockwellautomation.com/rockwellautomation/about-us/sustainability-ethics/product-environmental-compliance.page>.

Allen-Bradley, Guardmaster, PowerFlex, Rockwell Automation, and Rockwell Software are trademarks of Rockwell Automation, Inc.

EtherNet/IP is a trademark of ODVA, Inc.

Trademarks not belonging to Rockwell Automation are property of their respective companies.

Rockwell Otomasyon Ticaret A.Ş., Kar Plaza İş Merkezi E Blok Kat:6 34752 İçerenköy, İstanbul, Tel: +90 (216) 5698400

www.rockwellautomation.com

Power, Control and Information Solutions Headquarters

Americas: Rockwell Automation, 1201 South Second Street, Milwaukee, WI 53204-2496 USA, Tel: (1) 414.382.2000, Fax: (1) 414.382.4444

Europe/Middle East/Africa: Rockwell Automation NV, Pegasus Park, De Kleetlaan 12a, 1831 Diegem, Belgium, Tel: (32) 2 663 0600, Fax: (32) 2 663 0640

Asia Pacific: Rockwell Automation, Level 14, Core F, Cyberport 3, 100 Cyberport Road, Hong Kong, Tel: (852) 2887 4788, Fax: (852) 2508 1846

Publication 440R-UM012E-EN-P - November 2018

Supersedes Publication 440R-UM012D-EN-P - July 2016

Copyright © 2018 Rockwell Automation, Inc. All rights reserved. Printed in the U.S.A.