

simplicity *Plus*

ONE OR TWO LOOP
ANALOGUE ADDRESSABLE FIRE ALARM CONTROL PANEL



INSTALLATION MANUAL

CONTENTS

1. SAFETY INFORMATION.....	3
1.1 Installation Information	3
1.2 Safety Precautions during Normal Operation of Panel.....	3
1.3 Battery Information	3
1.4 Product Disposal at the end of its working life	3
2. PRODUCT DESIGN INFORMATION.....	4
2.1 Fire Alarm Control Section	4
2.2 Power Supply Section	4
2.3 Environmental	4
3. INTRODUCTION TO THE SIMPLICITY PANEL.....	5
3.1 Simplicity Panel History.....	5
3.2 Panel description & design concept	6
3.2.1 ADVANTAGES OF AN ADDRESSABLE FIRE ALARM SYSTEM	6
4 USING THIS MANUAL	7
4.1 Equipment guarantee	7
5 DESIGNING A SYSTEM	8
5.1 Designing a Simplicity System	8
6. INSTALLING THE SYSTEM.....	9
6.1 Considerations before Installation	9
6.1.1 MOUNTING THE CONTROL PANEL.....	9
6.1.2 RECOMMENDED CABLE TYPES AND THEIR LIMITATIONS	9
6.1.3 MAINS WIRING RECOMMENDATIONS.....	9
6.2 First Fix.....	10
6.2.1 MOUNTING THE FIRE ALARM PANEL	10
6.2.2 FIXING THE BACK BOX TO THE WALL	10
6.2.3 PLANNING CABLE ENTRY.....	10
6.2.4 CONNECTING THE MAINS POWER	11
6.2.5 CONNECTING THE BATTERIES	12
7 ADDRESSABLE LOOP WIRING.....	13
7.1 Specific device wiring instructions.....	14
7.2 Maximum loop length recommendations	15
7.3 Setting the device address (detectors, call points & sounders)	16
7.4 Address - zone table	16
8 SOUNDERS	18
8.1 Addressable sounders.....	18
8.2 Associated sounder bases	18
8.3 Addressable common sounder base.....	18
8.4 Addressable sounder circuit controller.....	18
8.5 Comparison of sounder types	18
9. AUXILIARY INPUTS & OUTPUTS.....	19
9.1 Auxiliary input wiring examples	19
9.2 Auxiliary output wiring	19
10. FIELD DEVICE TERMINATION	20
10.1 Terminating the wiring.....	20
11 OTHER CONNECTIONS	21
11.1 Repeater connection	21
11.2 Serial printer connection.....	21
12. CONFIGURING THE SIMPLICITY FIRE ALARM PANEL	22
12.1 Configuring the loops	22
12.1.1 FROM A BLANK SIMPLICITY PANEL	22
12.1.2 FROM A PREVIOUSLY CONFIGURED PANEL.....	22
12.1.2 REDUCED LOOP SIMPLICITY PANELS.....	22
12.2 Verifying the loop configuration	22
12.3 Labelling the loop devices	23
12.4 Configuring associated sounders	23
12.5 Setting time and date	23
12.6 Setting a custom banner	23
12.7 Changing a zone boundary	24
12.8 Changing the alarm response - sounders.....	25
12.8.1 CHANGING DETECTOR ALARM RESPONSE	25

12.8.2 CHANGING MCP ALARM RESPONSE	25
12.8.3 ZONAL SOUNDER TO COMMON SOUNDER DELAY	25
12.8.4 ASSOCIATED SOUNDER BASE SETTINGS	25
12.9 Changing the alarm response – I/O units.....	26
12.9.1 TYPES OF I/O UNIT OPERATION.....	26
12.9.2 SETTING DEFAULT I/O UNIT OPERATION	26
12.9.3 SETTING INDIVIDUAL I/O UNIT OPERATION.....	26
12.10 Setting the LCD language	26
12.11 Software Versions	27
12.12 Protocol	27
13 ALARM VERIFICATION	28
13.1 How Alarm Verification Works.....	28
13.2 Setting the Alarm Verification Delay.....	28
13.3 Applying Alarm Verification Delay to a detector	28
14 RESTORING THE PANELS DEFAULT SETTINGS	29
15 VIEWING PANEL INFORMATION	30
15.1 Menu Structure	30
15.2 Viewing device status.....	31
15.3 Locating a device	31
15.4 Using the event log.....	32
16. THE FIRE ALARM CONDITION.....	33
16.1 Viewing a fire alarm event.....	33
16.2 Viewing Faults during a fire alarm condition	33
16.3 Viewing Zone Disablements during a fire alarm condition	33
16.4 Viewing Device Disablements during a fire alarm condition	33
16.5 Viewing Zones in Test Mode during a fire alarm condition	33
17. DISABLEMENT	34
17.1 Zone disablement.....	34
17.2 To programme zone (or sounders) as disabled	34
17.3 Device disablement.....	35
17.4 Viewing disablements.....	35
17.4.1 VIEWING DISABLED ZONES	35
17.4.2 VIEWING DISABLED DEVICES.....	35
18. TEST MODE	36
18.1 Why use test mode.....	36
18.2 To programme zone in test mode	36
18.3 To program sounder circuits in test mode.....	36
19. GENERAL FAULT FINDING	37
19.1 Common fault.....	37
19.2 Loop contents fault finding	37
19.3 Zone faults.....	37
19.4 Supply faults.....	38
19.5 Earth faults	38
19.6 Double address	38
19.7 System fault.....	38
19.8 Pre-alarm.....	38
19.9 Sounder faults	39
19.10 Loop wiring faults	39
20. STANDBY BATTERY REQUIREMENTS	40
20.1 Standby battery calculation	41
21. PCB TERMINATION CONNECTIONS.....	42
21.1 Simplicity plus cie termination pcb	42
21.2 Connections	42
21.3 Simplicity plus power supply pcb	43
21.4 Simplicity plus power supply connections	43
21.5 Simplicity plus power supply fuses.....	43
22 SPECIFICATIONS.....	44
22.1 Enclosure specifications.....	44
22.2 Electrical specifications	44

1.SAFETY INFORMATION

WARNING: *Read this section completely before commencing installation.*

1.1 Installation Information

THIS FIRE ALARM CONTROL PANEL IS CLASS 1 EQUIPMENT AND MUST BE EARTHED

This equipment must be installed and maintained by a qualified and technically experienced person.

This C.I.E. must be wired to a fused spur rated at 3A. It must **NOT** be connected via a removable plug, or be connected through an RCD device.

Prior to commencing installation of the control panel, ensure that adequate precautions are taken to prevent damage to the sensitive electronic components on the display board and the control board due to electrostatic discharge. You should discharge any static electricity you may have accumulated by touching a convenient earthed object such as an unpainted copper radiator pipe. You should repeat the process at regular intervals during the installation process, especially if you are required to walk over carpets.

The panel must be located in a clean, dry position, which is not subject to excessive shock or vibration and at least 2 metres away from pager systems or any other radio transmitting equipment. The operating temperature range is 0°C to 40°C; maximum humidity is 95%.

HANDLING THE PCBs

If the PCBs are to be removed to ease fitting the enclosure and cables, care must be taken to avoid damage by static.

The best method is to wear an earth strap, but touching any earth point (eg building plumbing) will help to discharge any static. Always handle PCBs by their sides and avoid touching the legs of any components. Keep the PCBs away from damp dirty areas, e.g. in a small cardboard box.

1.2 Safety Precautions during Normal Operation of Panel

NOTE: When the Simplicity Plus panel is operating normally, i.e. not being tended by service personnel, the access door must be closed and locked. After locking, the key **MUST** be removed and **ONLY** held by the responsible person and / or the service personnel. It must under **NO CIRCUMSTANCES** be held by the user.

1.3 Battery Information

This C.I.E. uses 2 x 12V Sealed Lead Acid (SLA) batteries up to 12 Ah.

CAUTION:

RISK OF EXPLOSION IF BATTERY IS REPLACED BY AN INCORRECT TYPE.

DISPOSE OF USED BATTERIES ACCORDING TO BATTERY MANUFACTURERS INSTRUCTIONS

IMPORTANT NOTES ON BATTERIES:

DANGER: Batteries are electrically live at all times. **NEVER short circuit the battery terminals.**

WARNING: Batteries are often heavy; take great care when lifting and transporting batteries. For weights above 24 kilos, lifting aids should be used.

DANGER: Do NOT attempt to remove the battery lid or tamper with the internal workings of the battery. Electrolyte is a highly corrosive substance, and presents significant danger to yourself and to anything else it touches. In case of accidental skin or eye contact, flush the affected area with plenty of clean, fresh water and seek immediate medical attention.

Valve Regulated Lead Acid (VRLA) batteries are "low maintenance", requiring no electrolyte top-up or measurement of specific gravity.

1.4 Product Disposal at the end of its working life

Like all electronic equipment, at the end of its working life this unit should not be disposed of in a refuse bin. It should be taken to a local reprocessing site as per the guidelines of the WEEE directive, for correct disposal.



2. PRODUCT DESIGN INFORMATION

2.1 Fire Alarm Control Section

The Simplicity Plus Fire Alarm Control and Indicating Equipment (CIE) Has been designed to EN54-2:1998 A1 + A2 - Fire Detection & Fire Alarm Systems – Control & Indicating Equipment

As well as meeting the requirements of EN54-2:1998 A1 + A2, the Simplicity Plus also has the following options with requirements:-

Clause 7.8	Output to fire alarm devices (Option with requirements)
Clause 7.12	Dependencies on more than one alarm signal (Option with requirements)
Clause 8.3	Fault signals from points (Option with requirements)
Clause 9.5	Disabling of addressable points (Option with requirements)
Clause 10	Test Condition (Option with requirements)

The Simplicity Plus also has the following ancillary functions not required by the Standard:-

- Class Change Input to allow remote activation of sounders
- Serial repeater output (RS485)
- Serial Output Port (RS232)

2.2 Power Supply Section

The Simplicity Plus Fire Alarm Panels Power Supply Equipment (PSE) Has been designed to EN54-4:1998 A1 + A2 - Fire Detection & Fire Alarm Systems – Power Supply Equipment.

The PSE has been designed to charge batteries up to 12 Ah within the time limits specified by EN54-4.

The PSE will draw a maximum of 25mA from the battery in the event of mains failure.

The PSE is a switching power supply, with a supply rating (IMAX) of 2.0 Amps

The PSE has a 750mA limited charger output

2.3 Environmental

- It will operate in ambient temperatures of –5 to 40°C
- It will operate in a relative humidity of up to 95% (non condensing)
- It will withstand vibrations between 5 & 150 Hz
- The CIE & PSE should be maintained as described in section 3 of the User Manual, Maintenance Guide & Log Book.

3. INTRODUCTION TO THE SIMPLICITY PANEL

3.1 Simplicity Panel History

This manual covers the 3rd revision of the simplicity panel. Here is a brief history of the different versions:-



VERSION 1

VERSION 2

VERSION 3

Version 1: Simplicity 64 & Simplicity 126

The original simplicities had basic operation & no event log. The 2 versions had different PCBs, so a 64 is not upgradeable to a 126 version

Version 2: Simplicity Plus – plastic box

This had the following enhancements:-

- Real time clock
- Event Log (2048 events)
- Printer port (RS232)
- Repeater port on CPU card
- Improved fault messages
- Improved call point identification (Panel now identifies a call point alarm immediately)
- Improved sounder base starting & stopping time
- Option to disable individual devices or whole zones
- Detector LED & sounder can be operated from the menu to help identify devices
- Panel software version can be viewed through menu.

The 64 could be upgraded to a 126 by changing the CPU card.
(The Old version Simplicity 126 could also be upgraded to a Simplicity Plus by replacing the CPU card)

Version 3 Simplicity plus – Metal box

Version 3 of the Simplicity panel's main change is that it is now available as a 2 loop version. The other changes are:-

Redesigned to fit a metal enclosure
Separate EN54-4 PSU
The CPU card is now integrated on the display PCB, so is no longer user upgradable.
User definable zones
Option for zonal or common alarm operation
Options for I/O operation
Alarm Verification
User selectable languages
Option for Fyreye Mk 2 protocol

With this latest version, the panel still offers the simplicity of the previous versions, but also allows user configurations to zones & outputs to make the panel more flexible. If you need a manual for an earlier simplicity, please contact your supplier, or look on our website www.gltexports.com/archive

3.2 Panel description & design concept

The Simplicity Plus is a one or two loop analogue addressable fire alarm control panel designed to EN54 part 2 & 4. It is available in three versions. Simplicity 64 allows 64 devices to be connected to one loop, and divided into 4 zones. Simplicity Plus 126 allows 126 devices to be connected to one loop, and divided into 8 zones. Simplicity Plus 252 allows 252 devices to be connected as 2 loops of 126 devices, and divided into 8 zones.

The Simplicity has been designed to only use addressable sounders (so that all devices sit on the same wiring loop). By default all sounders on a Simplicity panel will activate on any alarm.

It has been designed to give the advantages of an addressable system, with the simplicity of a conventional system. To help achieve this, the Simplicity Plus uses default values to cut out many of the programming steps normally associated with addressable panels. It also uses its LEDs as the primary source of zone event information. The screen information is supplementary, to help identify loop device alarm or fault locations, and to help in configuring the panel.

3.2.1 ADVANTAGES OF AN ADDRESSABLE FIRE ALARM SYSTEM

The table below lists the main advantages of addressable systems, and how our panels use them.

FEATURE	PREMIER AL	PREMIER QUATRO	SIMPLICITY
UNIQUE ALARM IDENTIFICATION	PANEL, LOOP & ADDRESS	PANEL, LOOP & ADDRESS	LOOP & ADDRESS
DEVICE LABEL	20 CHARACTERS	20 CHARACTERS for device, PLUS 20 Characters for the ZONE	20 CHARACTERS
PREALARM	PROGRAMMABLE LEVEL	PRESET @ 45	PRESET @ 45
DETECTOR SENSITIVITY	PROGRAMMABLE (INCLUDING DAY/NIGHT SENSITIVITY)	PRESET @ 55	PRESET @ 55
ZONE ALLOCATION	PROGRAMMABLE	PROGRAMMABLE	SET BY DEVICE ADDRESS
PROGRAMMING	FULL PROGRAMMABILITY	FULL PROGRAMMABILITY	COMMON OR ZONAL OPERATION ONLY
EVENT LOG	YES (200 EVENTS)	YES (4096 EVENTS)	YES (2048 EVENTS)

While all options are programmable on our Premier AL system, the Simplicity uses pre-configured settings for most options.

Device sensitivity and pre-alarm levels are preset.

To simplify configuration, there is no zone allocation programming. Instead each loop is split into 8 zones, and each device is assigned to a zone by the address set with its 8 way dip switch. The Default setting is:-

Panel	Zone 1	Zone 2	Zone 3	Zone 4	Zone 5	Zone 6	Zone 7	Zone 8
Simplicity Plus 64	Address 1-16	Address 17-32	Address 33-48	Address 49-64	N/A	N/A	N/A	N/A
Simplicity Plus 126	Address 1-16	Address 17-32	Address 33-48	Address 49-64	Address 65-80	Address 81-96	Address 97-112	Address 113-126
Simplicity Plus 252	Address 1:1-1:32	Address 1:33-1:64	Address 1:65-1:96	Address 1:97-1:126	Address 2:1-2:32	Address 2:33-2:64	Address 2:65-2:96	Address 2:97-2:126

On the Latest Revision of Simplicity Plus panel the zone boundaries can now be altered, to accommodate zones with larger or smaller device capacities. (See CHANGING A ZONE BOUNDARY on p 22)

The loop sounder operation is common by default. But can be altered to zonal operation if required (see CHANGING THE ALARM RESPONSE – SOUNDERS on p 23)

This leaves only the device label to be programmed by the installer. This is done with the built in keyboard.

4 USING THIS MANUAL

It is beyond the scope of this manual to teach the user all the intricacies of fire alarm system design. If in doubt about what is required, read BS 5839: Pt 1: 2002 "Fire Detection and Alarm Systems for buildings (UK Code of Practice for System Design, Installation, commissioning and maintenance)" available from the BSI, or at your local reference library. Other national regulations will also give similar guidance.

This manual explains, in a step-by-step manner, the procedure for the basic design and installation of the **Simplicity Plus** Range of Fire Alarm Control Panels.

It gives detailed instructions on how to use all the features on this fire alarm panel.

For operational and maintenance information, please refer to document GLT.MAN-108 (USER MANUAL, MAINTENANCE GUIDE & LOG BOOK). It also contains a System set-up table, and Installation Certificate, that must be completed by the Commissioning Engineer prior to system handover.

Unlike the User Manual, this Installation Manual must not be left accessible to the User.

4.1 Equipment guarantee

If this equipment is not fitted and commissioned according to our guidelines, and the relevant National Standards, by an approved and competent person or organisation, the warranty may become void.

5 DESIGNING A SYSTEM

This manual is not designed to teach Fire Alarm System design. It is assumed that the System has been designed by a competent person, and that the installer has an understanding of Fire Alarm System components and their use.

We strongly recommend consultation with a suitably qualified, competent person regarding the design of the Fire Alarm System. The System must be commissioned and serviced in accordance with our instructions and the relevant National Standards. Contact the Fire Officer concerned with the property at an early stage in case he has any special requirements. If in doubt, read BS 5839: Pt 1: 2002 "Fire Detection and Alarm Systems for buildings (Code of Practice for System Design, Installation, commissioning and maintenance)" available from the BSI, or at your local reference library.

5.1 Designing a Simplicity System

Designing a Simplicity Plus System is a fairly straightforward matter. It just takes a bit of thought to zone allocation during the system design stage. We believe that the default configuration of 16 devices per zone (for Simplicity Plus 64 & 126), and common alarm operation are suitable for most applications. Simplicity Plus 252 has the default configuration of 32 devices per zone, with 4 zones per loop, but these zone boundaries can be moved if so desired. The example (1) below is for a Simplicity Plus 126 panel.

1. Decide on the zone allocation for the system. Each default zone can have a maximum of 16 devices fitted. Consider the simplified 3-storey building below.

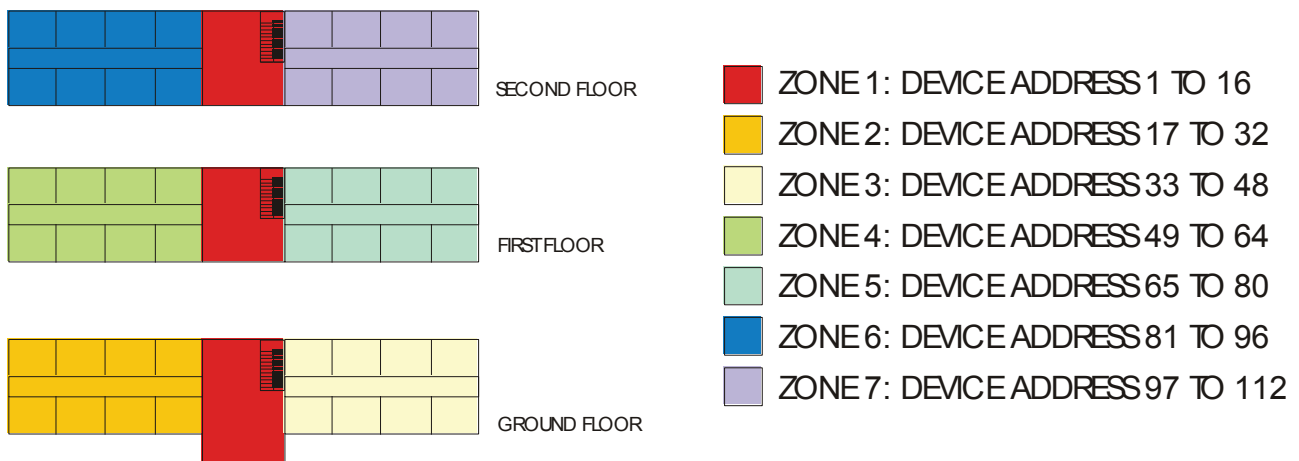

The advantage of this method of zone allocation is that it simplifies the panel setup by eliminating a programming stage.

(Note that a Simplicity 64 can only have 4 zones, so would not be suitable for the above system)

The main disadvantage of this method of zone allocation is the maximum zone capacity of 16 devices. If a zone has more than 16 devices it would need to be split into smaller zones. Similarly, a zone with only one device would leave 15 empty addresses on that zone.

To overcome this limitation, the Simplicity Plus now allows the zone boundaries to be moved. (See CHANGING A ZONE BOUNDARY on p 22). NOTE: When changing the zone boundaries, consider if there are likely to be extra devices added to that zone before commissioning is complete, and whether it is worth allowing 2 or 3 empty addresses in a zone.

2. Sounder operation. On the Simplicity Panels, the default setting is common sounders, i.e. an alarm signal from any device will activate all sounders. If zonal sounder operation is required the simplicity can now configure sounders to trigger zonally when an alarm comes from a detector, a call point, or both (see CHANGING THE ALARM RESPONSE – SOUNDERS on p 23).

If more sophisticated sounder & I/O operation is needed, ask your dealer about the Premier Quatro & Premier AL Fire Alarm Panels.

3. Whenever possible, give each device as descriptive a label as possible. The better the description, the easier it is to locate in the event of an alarm. The panel allows 20 characters. It may be necessary to use abbreviations to achieve the required label.

4. Keep the design of the system, and any changes to it well documented. This makes it easier to trace any configuration errors during installation & commissioning.

6. INSTALLING THE SYSTEM

6.1 Considerations before Installation

6.1.1 MOUNTING THE CONTROL PANEL

The control panel should be installed in accordance with the following recommendations:-

- The panel should be close to the main entrance of the building, so that it can be viewed by any fire-fighting personnel entering the building.
- It should be fitted to a sturdy wall that will not flex unnecessarily.
- It should be mounted at eye level, in order for it to be viewed without need of a ladder.
- It should be installed in a dry, weatherproof place, preferably NOT in direct sunlight.
- It should be easily accessible, so that the responsible person can perform their regular fire alarm checks.

6.1.2 RECOMMENDED CABLE TYPES AND THEIR LIMITATIONS

All wiring must be installed to meet BS5839: Pt1: 2002 and BS 7671 (Wiring Regs) standards. Other National standards of fire alarm system installation should be adhered to where applicable.

Screened cables should be used throughout the installation to help shield the Panel from outside interference and ensure EMC compatibility.

The two categories of cable according to BS5839: Pt1: 2002, Clause 26 "Fire Detection and Alarm Systems for Buildings (Code of Practice for System Design, Installation and Servicing)" are:

Standard fire resisting cable – to PH30 classification of EN 50200
Enhanced fire resisting cable – to PH120 classification of EN 50200
(Note that all cables should be at least 1mm² cross section)

On the Simplicity Panel the general recommendation would be to use standard fire resistant cable, such as Zeta Alarm Systems Fire Defence Cable, Firetuff™, FP200 or any equivalent. These cables are screened, and will provide good EMC shielding when properly grounded at the panel. Certain system specifications may demand the use of a particular type of cable and due regard should be paid to this fact.

Depending on the environment, the cables may need mechanical protection (such as a conduit).

6.1.3 MAINS WIRING RECOMMENDATIONS

The Mains supply to the FACP is fixed wiring, using **Fire resisting** 3-core cable (Between 1 mm² and 2.5mm²) or a suitable 3-conductor system, fed from an isolating double pole switch fused spur, fused at 3A. **IT SHOULD NOT BE CONNECTED THROUGH AN RCD.** This should be secure from unauthorised operation and be marked 'FIRE ALARM: DO NOT SWITCH OFF'. The supply must be exclusive to the Fire Panel. **MAKE SURE ANY SPARE ENTRY HOLES ARE COVERED WITH THE GROMMETS PROVIDED**

For information on how to connect Mains to the Panel's Power Supply PCB, see page 11. Also refer to rating information on the mains cover inside the FACP.

6.2 First Fix

6.2.1 MOUNTING THE FIRE ALARM PANEL

The Simplicity comes with many cable entry holes. If another entry hole is required, it is strongly recommended that the panels door be removed to avoid accidental damage. Also, the termination and Power Supply PCBs should be removed and stored in a safe place. This would also help while fixing the back box to the wall.

6.2.2 FIXING THE BACK BOX TO THE WALL

Figure 2: Plan view inside the enclosure without PCBs. Side view for surface installation.

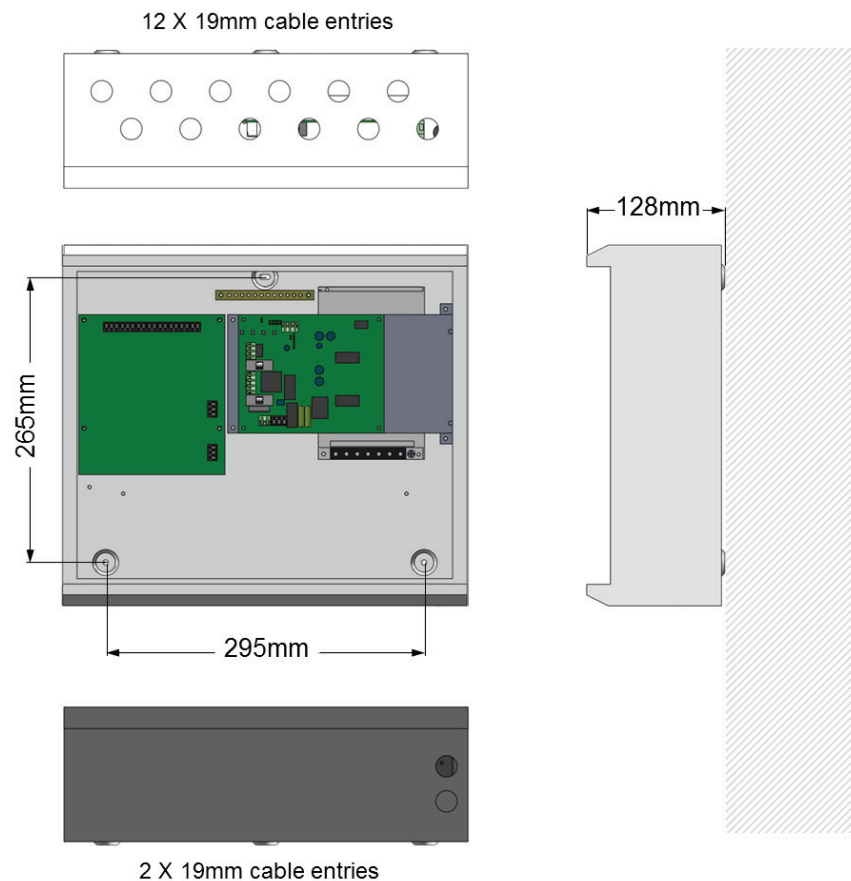

Fix the enclosure to the wall using the three mounting holes provided.

Check the build & condition of the wall to decide a suitable screw fixing.

The mounting holes are designed for No 8 roundhead or countersunk woodscrews (or similar).

Remove any debris from the enclosure.

Take care not to damage the FACP during installation.

6.2.3 PLANNING CABLE ENTRY

Fig.2 above shows the location of the cable entries to facilitate planning of wiring (home runs) to be brought to the panel.

The grommets can be easily removed by a push from inside the control panel box.

If a grommet is removed, fill the hole with a brass cable gland. If any knockout is removed, but subsequently not used, it should be covered up.

The 230Va.c. Mains cable must be fed into the enclosure via one of the cable entries at the top right corner of the back box. (Refer to "Connecting the Mains" on Following Page).

6.2.4 CONNECTING THE MAINS POWER

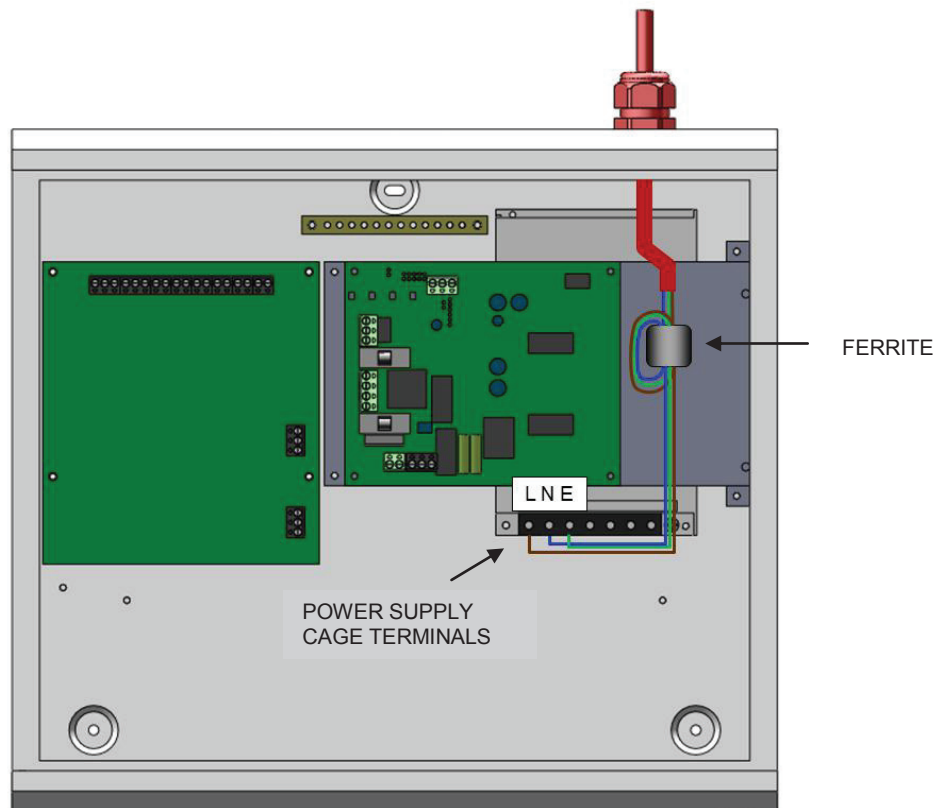

Figure 3: Power Supply PCB layout and Mains connection details

The panel should be connected to 230V AC by a 3A rated spur to the fuse box with 1mm² to 2.5mm² 3-core cable. Nothing else should be connected to this supply. The cable should be fire resistant.

Having entered the panel via the cable gland, the mains cable should be passed twice through the provided ferrite. This is made easier by removing the outer insulation. The cable is then connected to the Live, Earth and Neutral connections marked on the power supply cage. The Mains is protected by an INTERNAL fuse on the PSU cage. (This fuse is not user replaceable)

The incoming mains cable should be kept separate from the addressable loop cables to help minimise mains interference.

MAKE SURE ANY SPARE ENTRY HOLES ARE COVERED WITH THE PLASTIC GROMMETS PROVIDED

It is advisable to apply power to the panel before connecting any devices, to check for correct operation, and to familiarise yourself with the fire alarm panels controls.

6.2.5 CONNECTING THE BATTERIES

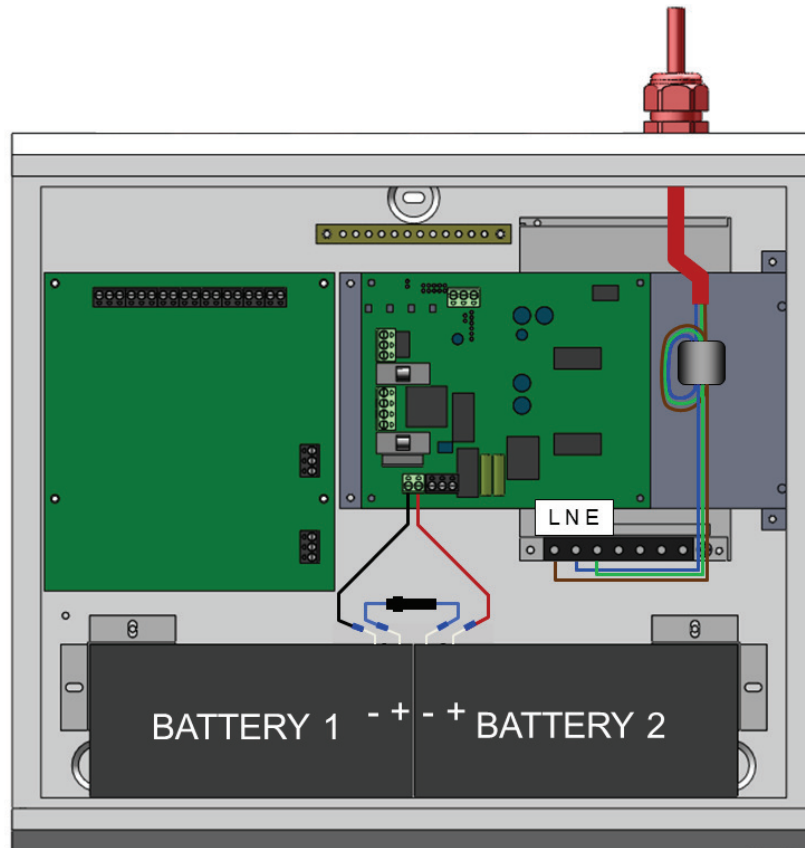

Figure 4: Battery location and connection details

Although there are many sizes of suitable battery, the sizes we usually recommend for the SIMPLICITY are 12V 7Ah or 12V 12 Ah, depending on the load.

To calculate the exact requirement, use the equation in section 20.1, STANDBY BATTERY CALCULATIONS

The two batteries are wired in **series** to give **24 Volts**.

Connect the **-ve** of Battery 1 to the **black** battery charger lead.

Connect the **+ve** of Battery 2 to the **red** battery charger lead.

The +ve of the first battery is connected to the -ve of the second battery using the FUSED link wire supplied.

When fitting the batteries, take care not to damage the temperature monitoring thermistor. (Next to the charger lead connections). This is used to prevent overcharging the batteries in high ambient temperatures.

7 ADDRESSABLE LOOP WIRING

The Simplicity Plus 64 and 126 can connect to one addressable loop. Addressable detectors, addressable call points, addressable loop powered sounders and several other interface units can be connected to this loop. A MAXIMUM OF 64 DEVICES CAN BE CONNECTED TO THE LOOP WHEN POWERED BY THE SIMPLICITY 64 PANEL, AND 126 DEVICES WHEN POWERED BY THE SIMPLICITY 126 PANEL. The Simplicity Plus 252 panel can connect to one or two loops. A MAXIMUM OF 126 DEVICES CAN BE CONNECTED TO EACH OF THE TWO LOOPS. We recommend that the first and last devices on a loop have isolator bases fitted. Also the last device on each zone should have an isolator fitted. This is to prevent a short circuit fault in one zone affecting another zone.

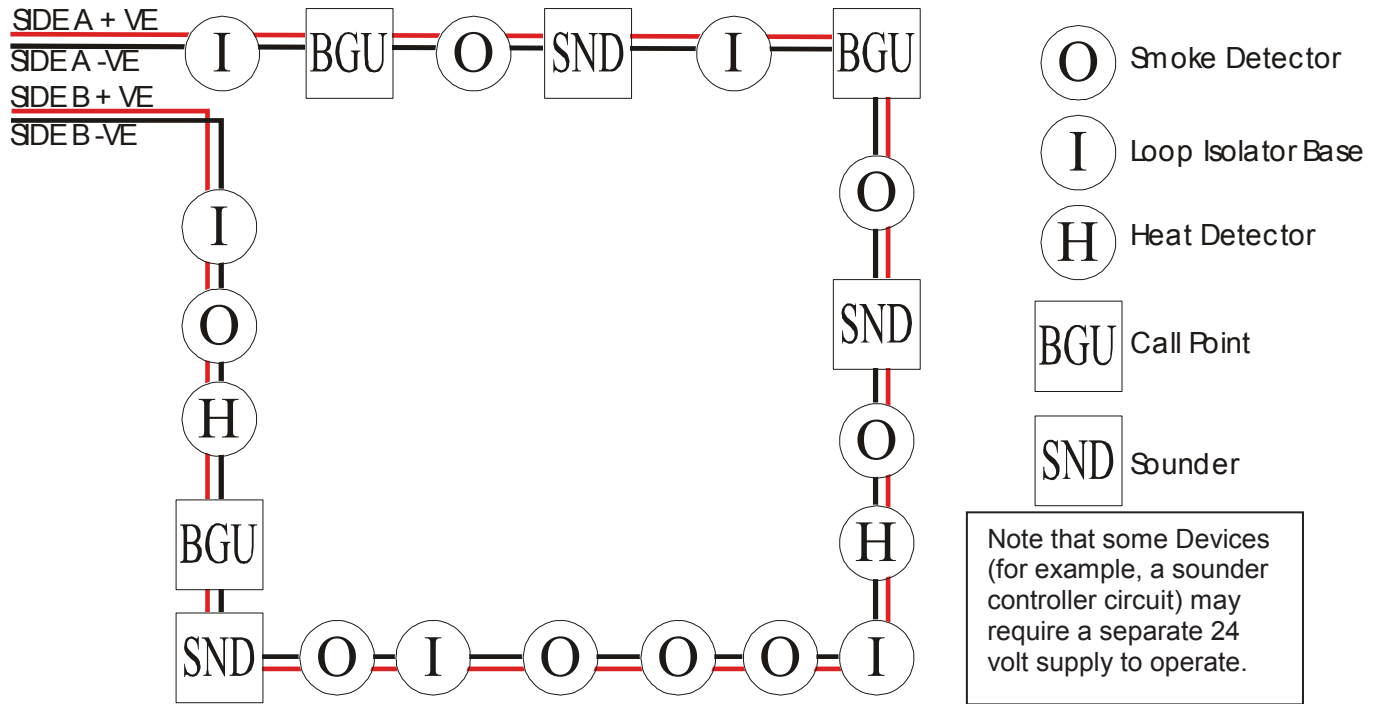

A maximum of 32 loop-powered addressable sounders or sounder bases are permitted on a loop. On the Simplicity Panel, Sounder Bases are configured as common sounders, unless the Sounder Base is used with the Alarm Verification feature (see Sections 8 & 13).

Short circuit isolators should be used to prevent losing the whole loop in the event of a single short circuit fault. They should be fitted to each zone boundary, such that any short circuit will only affect the devices in 1 zone.

The termination of each wiring circuit must be as indicated on the main PCB (See Fig 6). The Earthing of the cable screens should be as shown in Fig 6.

Pre-Commissioning Cable Checks

1. +ve in to +ve out less than 24 ohms
2. -ve in to -ve out less than 24 ohms (may need to temporarily disable isolators to measure)
3. +ve to -ve greater than 500k ohm
4. +ve to Earth greater than 1M ohm.
5. -ve to Earth greater than 1M ohm.
6. +ve to -ve less than 50 mV pickup (on AC & DC scales)

7.1 Specific device wiring instructions

All products will come with their own wiring instructions. This should be used when connecting a product. But as a general guideline, here are the connection details of most Zeta Addressable products. Please note that if the Securetone 2 sounder is used as a base sounder, the flying leads must be connected to the base of the associated detector.

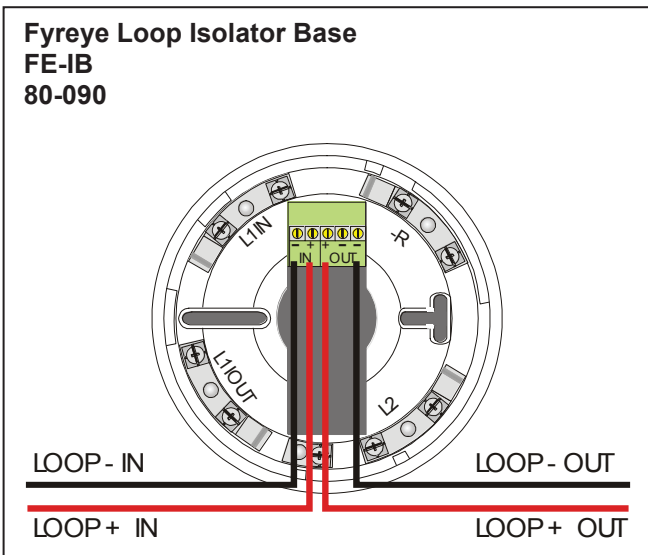
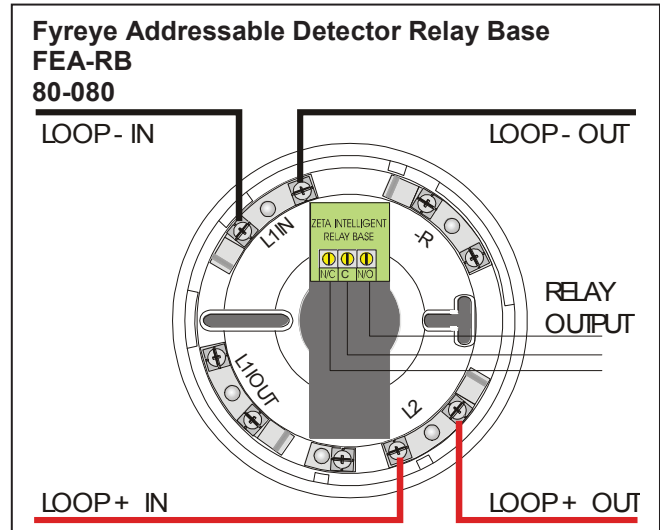
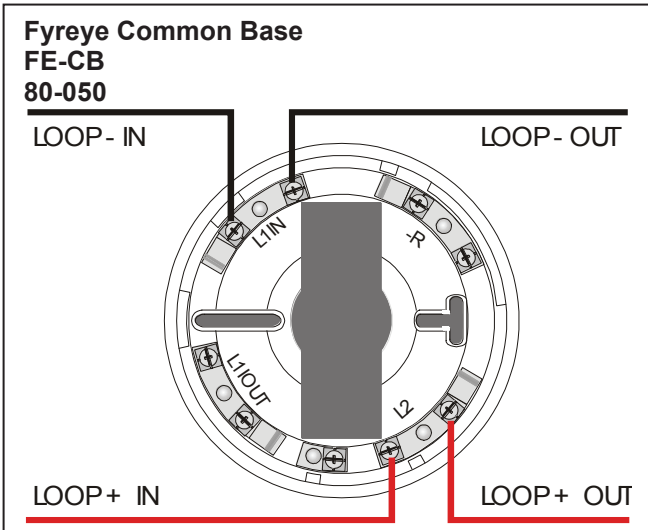

Note that on the Fyreye Loop Isolator Base, the loop wiring connects to the terminal block on the PCB and NOT to the Base Spring Screws.

The terminals are marked + & - in, and +,- &- out.

The second -ve contact can be used during commissioning to check the loop integrity.

(Connect the -in to the spare - out. Repeat for all isolators. Measure -ve line resistance with a DVM. Return the -in cable to its original terminal block when tests completed.)

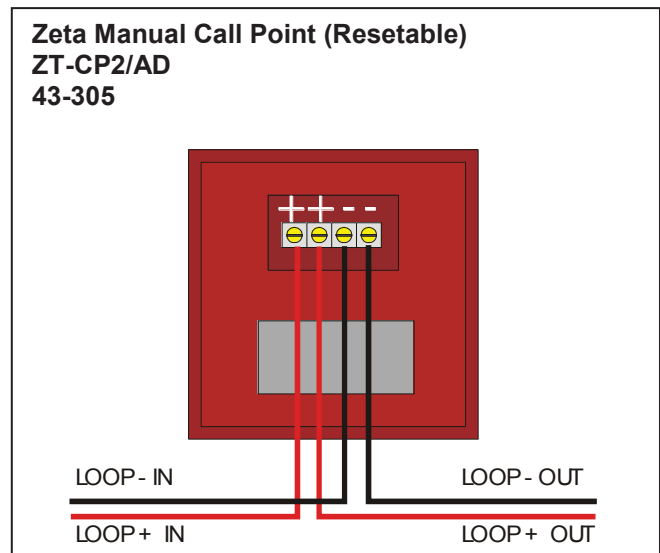
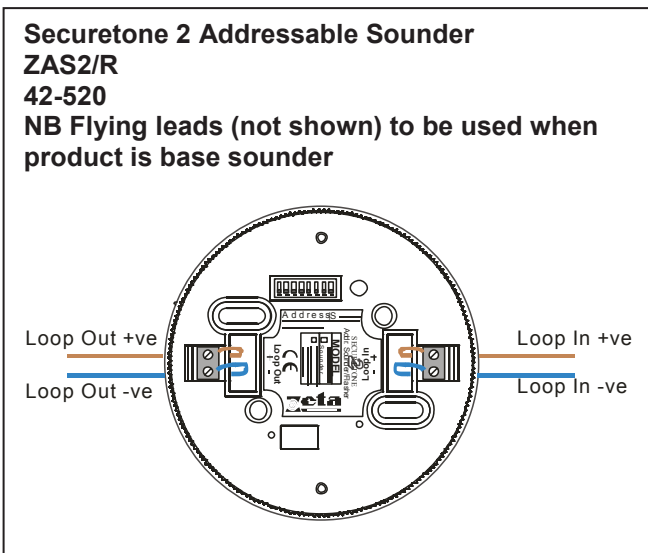

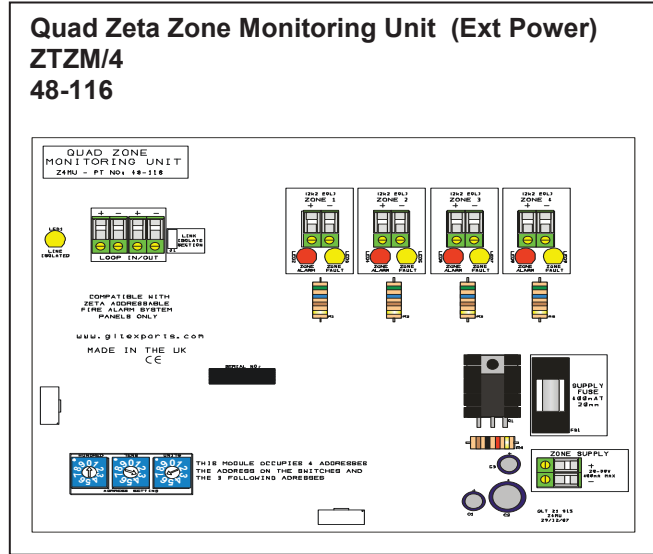
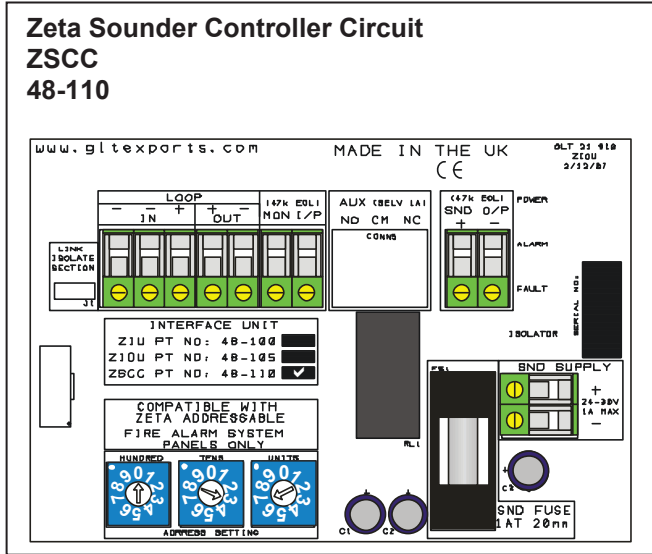
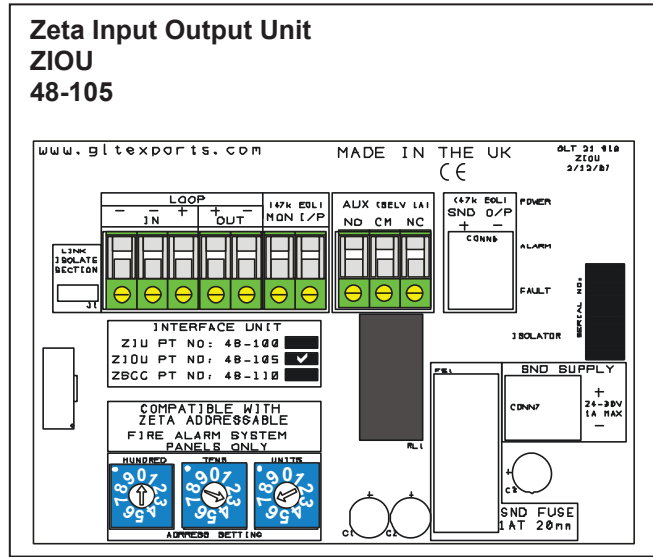
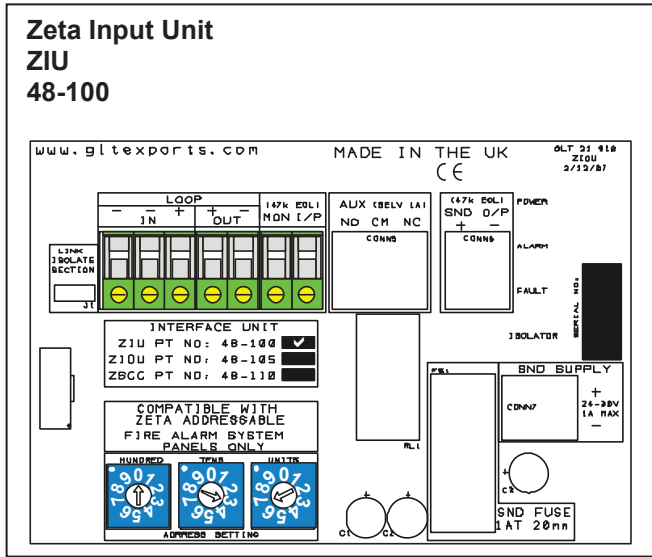

7.2 Maximum loop length recommendations

With an addressable system, some care must be taken when calculating the appropriate cable gauge for the system.

The main limitation is that during an alarm condition (maximum current draw), the voltage at all devices must be at least 17 Volts with at least 5V of superimposed data signal.

The exact calculation equations are beyond the scope of this manual, because of the distributed load of the sounders on the loop, but the following table gives a rough guide for maximum cable lengths at various current loads for 3 different cable gauges

Maximum Loop Current (in Alarm)	500 mA	400 mA	300 mA	200 mA
1.0mm CSA cable	500 m	625 m	830 m	1250 m
1.5mm CSA cable	750 m	930 m	1250 m	1870 m
2.5mm CSA cable	1000 m	1250 m	1660 m	2500 m

EG. A system with a maximum load of 300mA using 1.5mm cable can have a maximum loop run of 1250 m end to end.

7.3 Setting the device address (detectors, call points & sounders)

The device address is set with a dip switch on the rear of the device.

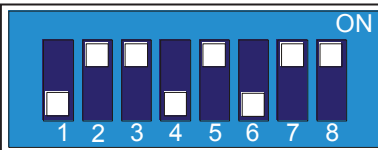

The address setting is binary, with the **ON** position being binary **0**, and the **OFF** position being binary **1**. Switch 8 is not used for setting the address, but sometimes has a device specific function. (check instructions that came with the device)

If you are not familiar with binary, check the table on page 14, or use the following rule:

Switch 7 off = add 64,
 Switch 6 off = add 32,
 Switch 5 off = add 16,
 Switch 4 off = add 8,
 Switch 3 off = add 4,
 Switch 2 off = add 2,
 Switch 1 off = add 1.

The example shown would be:
 switches 6, 4 & 1
 =32 + 8 + 1 = Address 41

7.4 Address - zone table

On the Simplicity 64 and 126, each available address corresponds to a zone, with 1-16 being in zone 1 by default, 17-32 being in zone 2 by default, 33-48 in zone 3 by default etc. On the Simplicity 252, by default addresses 1-32 are in zone 1, 33-64 in zone 2 etc

The following table shows the dip switch settings for each address, and the DEFAULT zone that address will be in.

Note that if the zone boundaries on Simplicity 252 are changed, the affected addresses will now be in a different zone.

ADDRESS	SWITCHES	ADDRESS	SWITCHES	ADDRESS	SWITCHES	ADDRESS	SWITCHES
0 =	n o T u s e d		1 2 3 4 5 6 7		1 2 3 4 5 6 7		1 2 3 4 5 6 7
1 =	off on On on on on on	32 =	on on on on on off on	64 =	on on on on on on off	96 =	on on on on on on off
2 =	on off On on on on on	33 =	off on on on on off on	65 =	off on on on on on off	97 =	off on on on on on off
3 =	off off On on on on on	34 =	on off on on on on off	66 =	on off on on on on off	98 =	on off on on on on off
4 =	on on On on on on on	35 =	off off on on on on off	67 =	off off on on on on off	99 =	off off on on on on off
5 =	off on Off on on on on	36 =	on on off on on on off	68 =	on on off on on on off	100 =	on on off on on on off
6 =	on off Off on on on on	37 =	off on off on on on off	69 =	off on off on on on off	101 =	off on off on on on off
7 =	off off Off on on on on	38 =	on off on on on on off	70 =	on off on on on on off	102 =	on off on on on on off
8 =	on on On off on on on	39 =	off off on on on on off	71 =	off off on on on on off	103 =	off off on on on on off
9 =	off on On off on on on	40 =	on on on off on on off	72 =	on on on off on on off	104 =	on on on off on on off
10 =	on off On off on on on	41 =	off on on off on on off	73 =	off on on off on on off	105 =	off on on off on on off
11 =	off off On off on on on	42 =	on off on off on on off	74 =	on off on off on on off	106 =	on off on off on on off
12 =	on on On off on on on	43 =	off on on off on on off	75 =	off on on off on on off	107 =	off on on off on on off
13 =	off on Off off on on on	44 =	on on on off on on off	76 =	on on on off on on off	108 =	on on on off on on off
14 =	on off Off off on on on	45 =	off on off off on on off	77 =	off on off off on on off	109 =	off on off off on on off
15 =	off off Off off on on on	46 =	on off off off on on off	78 =	on off off off on on off	110 =	on off off off on on off
16 =	on on On on on off on on	47 =	off off off off on on off	79 =	off off off off on on off	111 =	off off off off on on off
17 =	off on On on on off on on	48 =	on on on on off on on	80 =	on on on on off on on	112 =	on on on on off on on
18 =	on off On on on off on on	49 =	off on on on off on on	81 =	off on on on off on on	113 =	off on on on off on on
19 =	off off On on on off on on	50 =	on off on on off on on	82 =	on off on on off on on	114 =	on off on on off on on
20 =	on on On on on off on on	51 =	off off on on off on on	83 =	off off on on off on on	115 =	off off on on off on on
21 =	off on Off on on off on on	52 =	on on on on off on on	84 =	on on on on off on on	116 =	on on on on off on on
22 =	on off Off on on off on on	53 =	off on on on off on on	85 =	off on on on off on on	117 =	off on on on off on on
23 =	off off Off on on off on on	54 =	on off on on off on on	86 =	on off on on off on on	118 =	on off on on off on on
24 =	on on On on on off on on	55 =	off off on on off on on	87 =	off off on on off on on	119 =	off off on on off on on
25 =	off on On on on off on on	56 =	on on on on off on on	88 =	on on on on off on on	120 =	on on on on off on on
26 =	on off On on on off on on	57 =	off on on on off on on	89 =	off on on on off on on	121 =	off on on on off on on
27 =	off off On on on off on on	58 =	on on on on off on on	90 =	on on on on off on on	122 =	on on on on off on on
28 =	on on Off off on on on	59 =	off on on on off on on	91 =	off on on on off on on	123 =	off on on on off on on
29 =	off on Off off on on on	60 =	on on on on off on on	92 =	on on on on off on on	124 =	on on on on off on on
30 =	on off Off off on on on	61 =	off on on on off on on	93 =	off on on on off on on	125 =	off on on on off on on
31 =	off off Off off on on on	62 =	on off on on off on on	94 =	on off on on off on on	126 =	on off on on off on on
		63 =	off off on on off on on	95 =	off off on on off on on	127 =	on on on on off on on

8 SOUNDERS

The Simplicity panel does not have any conventional sounder circuits on board. The idea of the simplicity is to connect everything to one circuit, so it only uses addressable sounders.

There are several types of addressable sounder that can be used on the simplicity, all with advantages & disadvantages. Choose the sounder type that is most suitable for the intended application.

8.1 Addressable sounders

These are standard addressable sounders. Each sounder is given a unique address, so that it can communicate with the control panel. Examples include the Zeta Addressable Maxitone & Zeta Addressable Securetone 2 sounders.

8.2 Associated sounder bases

Associated sounder bases (also known as platform sounders) do not communicate with the fire alarm panel. They are controlled by the detectors remote output signal. This means that when a panel configures the loop, it cannot see these sounders. The Simplicity assumes that any detector could have one of these sounders connected, so when an alarm signal comes, the panel sends the "turn on your remote output" to EVERY detector. This makes their operation slower than standard addressable detectors. Note that on SOME types of associated sounder, removing the detector will stop the sounder from being able to operate.

If not every detector has a sounder base fitted, it might be possible to speed up the sounder base start/stop time. See CONFIGURING ASSOCIATED SOUNDERS on page 23.

An example of an associated sounder base is the Zeta Addressable Securetone 2 sounder in shadow mode (switch 8 off).

8.3 Addressable common sounder base

This type of sounder (Zeta Common Sounder Base) was designed specifically for use with the earlier simplicity panels, where only common alarm was available. The sounders all listen to address 126. If they hear the start sounding command, they will all start together. (Of course this means that if the site needs individual sounder control, these sounders are not suitable)

8.4 Addressable sounder circuit controller

If conventional sounders or bells need to be fitted, then a sounder circuit controller can be used (Zeta Addressable Sounder Circuit Controller Unit). It will need to be separately powered. In operation, it will behave the same as an addressable sounder

8.5 Comparison of sounder types

The Simplicity supports 4 general sounder types; addressable, addressable sounder controller, Common sounder base and associated sounder base. All types have advantages & disadvantages.

Sounder type	Advantage	Disadvantage
Addressable	Device is seen by panel (so is monitored by protocol comms)	Tends to be more expensive Uses device address. Can't be used for alarm verification
Associated (sounder-base)	Doesn't occupy Device Address Can be used for the new alarm verification mode	Slow start time on heavy loaded loop MAY need detector present to operate.
Addressable Common sounder base	All sounders start instantly, and in sync	No individual control. Can't be used for alarm verification
Addressable Sounder Circuit Controller	Wide range of devices Devices tend to be cheaper. Can add many sounder circuits to system	Needs Extra Cabling. Needs External PSU Uses device address. Can't be used for alarm verification

If the site is to operate with common alarm only, then the common sounder base may be the best option.

If you need to use alarm verification, the associated sounder base is needed.

If you need bells or XENON flashers, you will need a sounder circuit controller.

9. AUXILIARY INPUTS & OUTPUTS

9.1 Auxiliary input wiring examples

There is one non-latching auxiliary input connection on the Fire Alarm Panel.

Class Change Input (CC): This will energise all alarm outputs continuously when the CC terminals are shorted together.

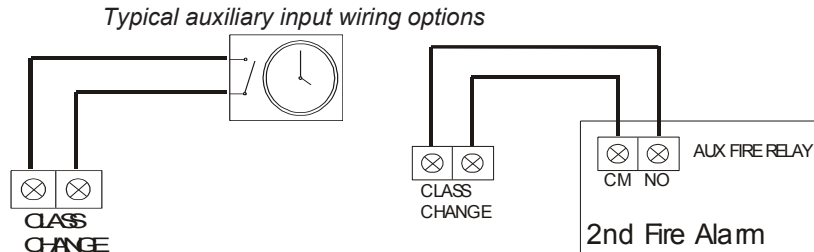

The termination for the above inputs must be as indicated on the main PCB (See page 15). The Earthing of the cable screens should be as shown on page 9.

9.2 Auxiliary output wiring

Auxiliary Fire Relay (AUX): This is a SELV volt free relay that operates in the alarm condition. It can be connected to emergency lights, local fire fighting equipment such as sprinkler systems, magnetic door holders, air conditioning shut off, etc. Extra alarm relays can be achieved by fitting extra ZIOUs to the addressable loop.

Fault Output (FAULT): This is a SELV volt free relay that operates in the Fault condition. It is Normally Energised, which ensures it can give a fault signal, even in the event of total power loss.

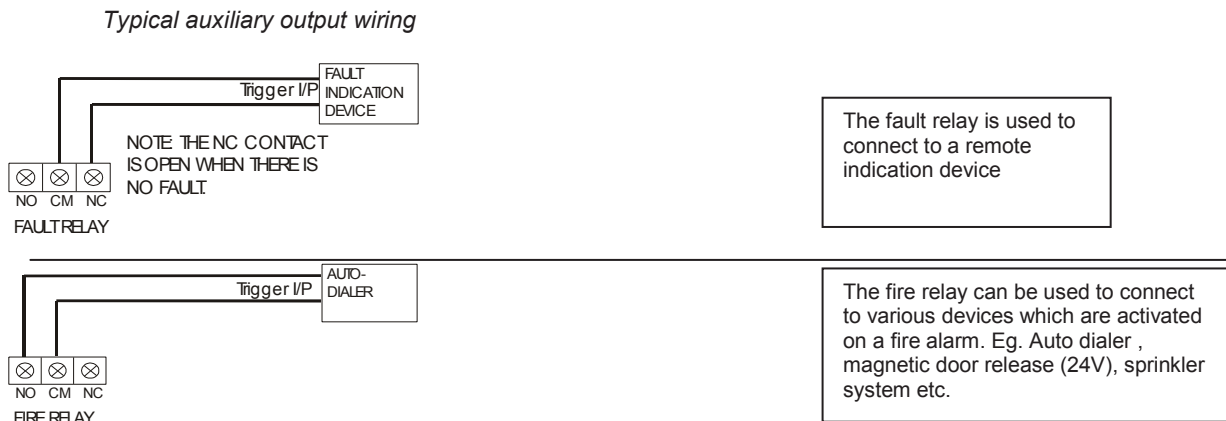

The Earthing of the cable screens should be as shown on the following page.

10. FIELD DEVICE TERMINATION

10.1 Terminating the wiring

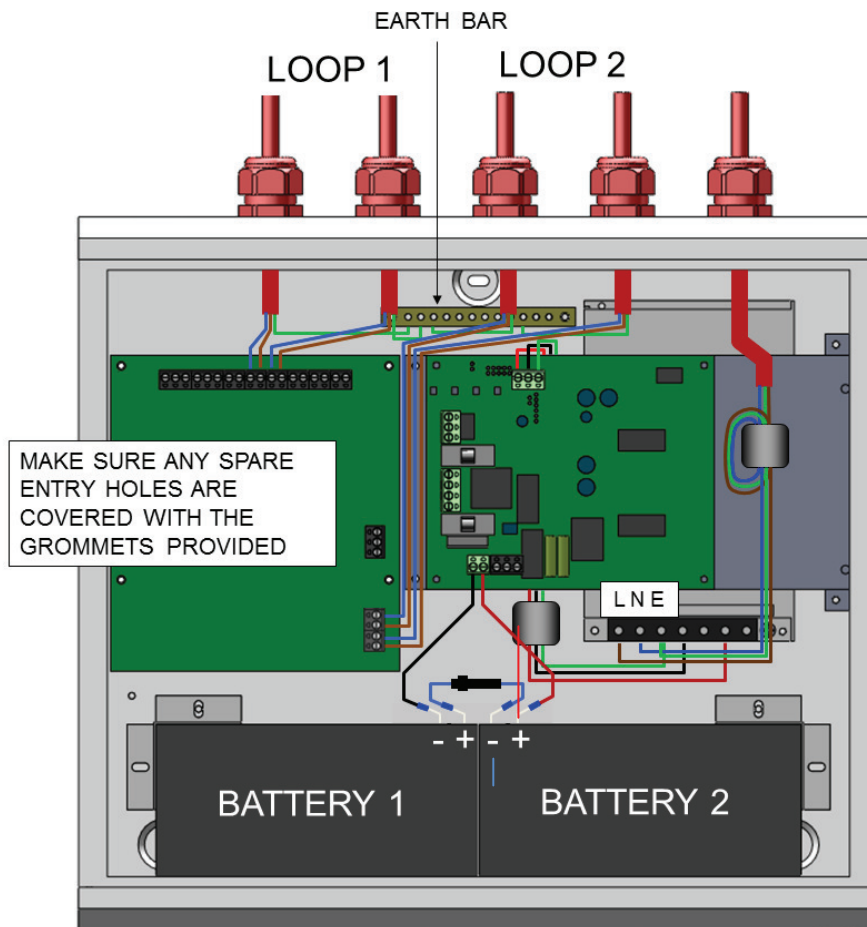

Figure 6: Cable connections

All cables entering the enclosure should have cable glands, which will prevent unwanted openings in the enclosure.

The Addressable Loop circuits should be connected to the appropriate connector block on the Termination PCB.

All cable screens should be terminated at the brass earthing strip as shown in Figure 6

11 OTHER CONNECTIONS

11.1 Repeater connection

The Simplicity has an RS485 connection for a serial repeater. The repeaters are display only (no control). A single repeater can be powered from the 24V DC outputs on the panel's Power Supply Unit (A or B). If 2 or more are to be connected, then they must be powered from external 24V power supplies. The panel supports up to 4 repeaters.

Connections

See Section 21 for the serial repeater connections.

11.2 Serial printer connection

The Simplicity has an RS232 Serial output that transmits panel events as they occur. It can connect to the Zeta TCP/IP Interface (Ask distributor for more details), or a serial printer. The recommended printer is an Epson LQ300 II+. The serial port on the Simplicity is configured to this printer's default settings. See also Section 21.

Connections

Simplicity	25 pin D connector
TX	Pin 3 (RX)
RX	Pin 2 (TX)
GND	Pin 7 (GND)
CTS	Pin 4 (RTS)
DSR	Pin 20 (DTR)

Serial Port Settings

Setting	Value
Baud Rate	19200
Data Bits	8
Stop bits	1
Parity	NO
Flow Control	Hardware

12. CONFIGURING THE SIMPLICITY FIRE ALARM PANEL

12.1 Configuring the loops

12.1.1 FROM A BLANK SIMPLICITY PANEL

1. After the system has been installed, and the cabling checked and the addresses of each device set, connect Loop 1 to the CIE termination PCB (connection 3 as shown in Section 21.1), and Loop 2 (if required) to the CIE termination PCB (connection 10), and power up the system (mains & batteries). The LCD should say "System Normal", and only the green Power LED will be lit. After a few seconds, the panel will find all the new devices & report them unconfigured

2. Press the enter button to configure the loop. The panel will show Configuration in progress for about 9 seconds, then it will then return to the system normal screen. The loop is now configured.

12.1.2 FROM A PREVIOUSLY CONFIGURED PANEL

1. Press Enter button. This will bring up Configuration Menu 1 (the user menu). In this Menu there are options to view loop contents, view the status of each device, or view the event log. The arrow in the bottom left hand corner shows that pressing NEXT will bring up a new screen.

(Note that if the panel has a fault on the screen, pressing enter will give fault details. Press cancel from the details screen to enter configuration Menu 1)

2. Press NEXT button. This will prompt for the access code to enter Configuration Menu 2 (the engineer menu). The access code for the Simplicity is 369

3. The panel now shows Configuration Menu 2. In this menu there are options to Configure the loops, to edit each device, and to configure the system options. The arrow in the bottom left hand corner shows that pressing PREVIOUS button will return to Configuration Menu 1

4. Press button 4 to configure the loop. The panel displays configuration in progress, Please wait. It will return to Configuration Menu 2 when completed.

12.1.2 REDUCED LOOP SIMPLICITY PANELS

For the reduced loop capacity Simplicity panels (EG Simplicity Micro, or Simplicity Plus 64), it is possible to address a device outside the panels range. Previous versions of simplicity panel would expect the user to find this problem by checking the device contents screen, and comparing to system drawings, but this latest version will warn that there are devices outside the panels address range, and help identify them.

12.2 Verifying the loop configuration

1. Go to Configuration menu 1 (either Press PREVIOUS button, from Menu 2, or press ENTER from System normal screen).

2. Press button 1 to view the loop contents. It lists the number of each type of device, the number of Double Addresses (DAD) on the system, the loop number (Loop 1 only), and the total number of devices on that loop. Check that the number of devices seen compares to the number expected. If it is different, refer to the fault finding guide.

3. The panel is now configured, and will function as a basic system, (press Cancel until screen shows system normal to run the panel), but it is more useful to enter device labels, to give a more precise location of an alarm device. We recommend that the device labels be entered to allow the panel to be more user friendly during normal operation.

```
Fire Alarm Panel
To EN54 pt2 & pt4
System Normal
15-01-2006 12:59
```

```
Devices Found

Press ENTER to
Configure Panel
```

```
Configuration in
Progress

Please Wait
```

```
Configuration Menu 1
1:Loop Contents
2:Device Status
3:Event logs >
```

```
Enter Access Code

***
```

```
Configuration Menu 2
4:Configure Loops
5:Edit Device
6:Config System <
```

```
Configuration in
Progress

Please Wait
```

```
Devices Outside
Address Range

ENT to turn on LED
```

```
Configuration Menu 1
1:Loop Contents
2:Device Status
3:Event logs >
```

```
CO 00 | SCC 14 | DAD 00
I/O 03 | ION 02 |
ZMU 01 | OPT 45 | Loop 1
HET 07 | BGU 05 | Tot 77
```

12.3 Labelling the loop devices

1. To add a label, go to configuration menu 2 as described above. Select option 5 to Edit Device. Use Next / Previous to select the first device to edit. Press Enter, and a cursor will appear at the start of the 3rd line. Type in the 20 character label for this device, using the caps lock as necessary.
2. Press enter when the label has been entered. Press Next to edit the next device.
3. To skip many addresses, press 1 (for loop 1), or 2 (for loop 2 on a 2 loop simplicity.) The Panel will then prompt for the address. Type the address and press enter. The panel will now jump to this address.

NOTE: For many installations, only these configuration steps are required.

```
Optical
Analog: 25 Normal
Zone:01 Ad:016
```

```
Optical
Analog: 25 Normal
Fl 3 Bedroom 303
Zone:01 Ad:016
```

```
Enter Loop Address

Loop: 1
Address: 100
```

12.4 Configuring associated sounders

On the Simplicity, all detectors are treated as if they have an associated sounder base during the initial configuration (indicated by the sounder symbol in the top right hand corner of the edit device screen) . The panel will send the "activate base sounder" command to all address with this sounder symbol in the event of an alarm.

```
Optical
Analog: 25 Normal
Fl 3 Bedroom 303
Zone:01 Ad:016
```

If a loop contains a large number of detectors, and a small number of associated sounder bases, then the sounders might take a long time (between 4 & 8 seconds) to start.

If this scenario exists, it is possible to speed up operation as shown below. (Note: if every detector has a sounder base, or if most of the detectors have a sounder base this "speed up operation" will have little or no effect.

1. Press enter, NEXT, followed by 369 to enter Configuration Menu 2. Select option 5 to edit device status. Select a detector that does NOT have a sounder base attached.
2. Press the Disablement SELECT button. The sounder symbol turns off to show that this detector no longer has an associated sounder. (Pressing select again will continue to toggle the sounder on & off.)
3. Repeat for all detectors that do not have an associated sounder base fitted.

```
Optical
Analog: 25 Normal
Fl 3 Bedroom 303
Zone:01 Ad:016
```

If a system had say 40 detectors, but only 20 with an ASSOCIATED sounder base, configuring the sounders as shown above should half the sounder start time.

12.5 Setting time and date

To set the time & date, enter Configuration Menu 2 and select Configure System (6). The System Menu is now displayed. Select option 1 to set time & date. Enter the Day, Month, Year, Hour & Minutes as prompted, and press enter to save, or Cancel at any time to exit.

```
System Menu
1: Clock 4: Timing
2: Zones 5: Misc
3: Alarms 6: Reset
```

12.6 Setting a custom banner

On the Simplicity, the default screen shows Simplicity 64 or Simplicity 126 or Simplicity 252 on the 1st line of the LCD (depending on panel version), and Fire Alarm Panel on the 2nd line. This can be changed to any 2 lines of 20 Characters that are required. From Menu 2, select configure system, followed by MISC. In the Misc Menu, type **NaMe** (Caps lock ,**N** , Caps lock ,**a** , Caps lock ,**M** , Caps lock ,**e**). Then type the first line of text, followed by enter, then the second line of text, followed by enter. This message will now be the screen message when the panel is running normally, with no faults or alarms present.

12.7 Changing a zone boundary

The Simplicity's default zone allocation may not be suitable for every installation. The Zone boundaries can now be altered as follows:-

1. Enter Configuration Menu 2 & select System Menu (option 6)
2. Select Option 2 (Zones). The screen will show the Zone boundaries selection screen. The screen shows the currently selected zone, and the range of addresses within that zone. EG Zone 1 consists of addresses 1 to 16
3. Use Previous & Next buttons to select the zone to change, then press ENTER.
4. The Screen now prompts for the new last address of that zone to be entered. (On a 2 Loop simplicity, the panel will prompt for the loop number to be entered first)
5. Type in the address & press ENTER to save, or press CANCEL to keep the existing Address.
6. The Zone will now change to the selected boundary, with the first device of the next zone changing accordingly, e.g. just changing zone 1 last device to 10 would result in zone 1 being addresses 1 to 10, Zone 2 being 11 to 32, zone 3 being the default 33 to 48 etc. NOTE: If the building plans have not been finalised, it would be wise to leave a few spare addresses at the end of each zone, just in case extra devices need to be added.

The Simplicity Plus COULD use all addresses in a single zone, but it is good practice to limit a zone to 32 or less detectors (to avoid an unacceptably large zone search area). The minimum number of addresses per zone is 2.

All 8 zones do not need to be use, i.e. the 126 device version could be configured as 6 zones of 21 devices, leaving zones 7 & 8 void.

```
System Menu
1: Clock   4: Timing
2: Zones  5: Misc
3: Alarms  6: Reset
```

```
Zone Boundaries
Zone 1
001 - 016
ENTER to Change
```

```
Enter Last Device
Zone 1
010
Press ENTER to Save
```

```
Zone Boundaries
Zone 1
001 - 010
ENTER to Change
```

```
Zone Boundaries
Zone 2
011 - 032
ENTER to Change
```

12.8 Changing the alarm response - sounders

By Default, the Simplicity uses a common alarm configuration, i.e. any alarm sets off all sounders. This default operation may not be suitable for every installation. As alarms from Manual Call points often need to be treated differently, the operation of detectors & call Points can be configured separately. Enter the Configuration Menu 2 & select System Menu (option 6) and select option 3 (Alarms).

NOTE that if ADDRESSABLE COMMON SOUNDER BASES are used, the SOUNDER Response can ONLY be COMMON, as these sounders cannot be individually controlled.

```
System Menu
1: Clock  4: Timing
2: Zones  5: Misc
3: Alarms 6: Reset
```

```
Alarm Operation
1: Det    4: Bases
2: MCP    5: I/O
3: Sounder
```

12.8.1 CHANGING DETECTOR ALARM RESPONSE

To change the alarm response of detectors, select option 1. The following screen is Shown. Use Prev/Next buttons to scroll between the options Common and Zonal. Press enter to confirm.

```
Sounder Operation
Detector Alarm
Common
ENTER to Confirm
```

12.8.2 CHANGING MCP ALARM RESPONSE

To change the alarm response of manual call points, select option 2. The following screen is shown. Use Prev/Next buttons to scroll between the options Common and Zonal. Press enter to confirm.

```
Sounder Operation
Manual Call Point
Common
ENTER to Confirm
```

12.8.3 ZONAL SOUNDER TO COMMON SOUNDER DELAY

If Zonal sounder operation is selected, in the event of an alarm, the sounders will only ring in a certain part of the building (the zone that signalled the alarm). Sometimes there is a requirement to start all the other sounders if the alarm continues for a given time. On the Simplicity system, we refer to this as the Zonal to Common sounder time.

Select option 3 from the alarm operation menu. This zonal to common sounder time can either be disabled, i.e. alarms stay zonal, or it can be enabled, i.e. all the sounders will start after the programmed time delay.

To alter this delay, go to the System Menu and select option 4 (Timing)

```
Alarm Operation
1: Det    4: Bases
2: MCP    5: I/O
3: Sounder
```

```
Sounder Operation
Zonal-Common Time
Disabled
ENTER to Confirm
```

The panel will bring up the following menu. Select option 1 (Zonal to common)

```
System Menu
1: Clock  4: Timing
2: Zones  5: Misc
3: Alarms 6: Reset
```

```
Alarm Timing
1: Zonal to Common
2: Alarm Verify
```

The panel will now show the currently selected delay time. This can be set between 30 seconds and 10 minutes, in 15 second increments, using the previous and next buttons. Press enter to confirm the selected time.

```
Zonal-Common Time
0:30
ENTER to Confirm
```

12.8.4 ASSOCIATED SOUNDER BASE SETTINGS

On previous Simplicity Panels, associated sounder bases have always been common acting. There is now an option for them to be zonal. In the Alarm Operation Menu, select option 4 (bases).

Press Prev / Next to select common or Zonal operation, then press enter.

```
Alarm Operation
1: Det    4: Bases
2: MCP    5: I/O
3: Sounder
```

```
Sounder Operation
Sounder Bases
Common
ENTER to Confirm
```

12.9 Changing the alarm response – I/O units

Because a system could have several I/O units, each reacting to different types of events the simplicity system adopts the following method for configuring I/O units:-

1. Select a default I/O unit operation (This is done from the Alarm Operation Menu)
This will then be the default operation of all I/O units on the system.
2. Any I/O units which need a different operation can be edited individually from the edit device screen

12.9.1 TYPES OF I/O UNIT OPERATION

The simplicity now has the following types of I/O operation:-

I/O Com	Operates output on ANY alarm
I/O Zn-D	Operates it's output on a DETECTOR alarm from it's own ZONE
I/O Zn-A	Operates it's output on any alarm from it's own ZONE
I/O Addr	Operates it's output ONLY when it's own INPUT is triggered
I/O Link	Special type used for Inter-panel link. Output operates on any alarm , EXCEPT from its own address, AND the input is non latching and behaves similar to class change.

12.9.2 SETTING DEFAULT I/O UNIT OPERATION

To set the simplicity panels default I/O operation, enter configuration menu 2, then select config system to bring up the system menu

```
System Menu
1: Clock  4: Timing
2: Zones  5: Misc
3: Alarms 6: Reset
```

Select Option 3 (Alarms) to bring up the alarm operation Menu.

```
Alarm Operation
1: Det    4: Bases
2: MCP    5: I/O
3: Sounder
```

Select option 5 (I/O). This brings up the following screen.

```
I/O Unit Operation
Common

ENTER to Confirm
```

Press Prev & Next to select the default operation, then press enter.

12.9.3 SETTING INDIVIDUAL I/O UNIT OPERATION

To alter the operation mode of an individual I/O unit, go to configuration menu 2

```
Configuration Menu 2
4:Configure Loops
5:Edit Device
6:Config System  <
```

Select Edit Device.

Scroll to the required Address

```
I/O-COM 
Analog: 16 Normal
Interface to Main FA
Zone:01      Ad:013
```

Press V to cycle through the different Variations of I/O configuration

12.10 Setting the LCD language

From Configuration menu 2, Select configure system (option 6)

```
System Menu
1: Clock  4: Timing
2: Zones  5: Misc
3: Alarms 6: Reset
```

Then from the Misc Settings menu, select option 1 (Language)

```
Misc Settings
1: Language
2: Version Info
3: Protocol
```

Pressing Prev / Next will scroll through the available languages.

The currently supported languages are:-

- English
- Spanish
- Portuguese
- Hungarian
- French

```
Set Language
English

Press ENTER to Save
```

Other languages are available on request.

12.11 Software Versions

From Configuration menu 2, Select configure system (option 6)

Then from the Misc Settings menu, select option 2 (Version Info)

The panel will display the software versions in its two Microcontrollers, one for the main functions and one for the Loop Driver. This information may be useful for technical support in the Event of any problems occurring with the Control Panel.

```
Misc Settings
1: Language
2: Version Info
3: Protocol
```

```
GLT Exports Ltd
Simplicity 252
Panel : r7255
Loop : r7152
```

(Note that the revision number is an internal reference number. It does not mean that there have been 7000+ software revisions)

12.12 Protocol

The Simplicity Panel now supports 2 addressable protocols. The Original Zeta Addressable Protocol, and the new Fyreye Mk II Protocol. The New protocol has been introduced to allow future development of our products, but is unfortunately incompatible with the original Protocol.

Check the information below and select the correct protocol for the devices you have on the system.

Original Fyreye Detectors (1 LED)



FEAO2000

FEAH2000

Use **STANDARD** Protocol setting

Fyreye Extra Detectors (2 LED)



FEAOE2000

FEAHE2000

Use **STANDARD** Protocol setting

Fyreye MK II Detectors (8 LED)



FEII-AOP

FEII-AHR

Use **FYREYE MK II** Protocol setting

Changing the protocol

From Configuration menu 2, Select configure system (option 6)

Then from the Misc Settings menu, select option 3 (Protocol)

Press Prev / Next to select Standard or Fyreye-Mk2 protocol, and then press ENTER.

```
Select Protocol
Fyreye-Mk2
ENTER to Confirm
```

NOTE: The Factory Default option will reset the panel to the Fyreye Mk II Protocol. If your system is running the standard Zeta protocol devices, then you will need to change the protocol (as described above) before the panel will see the devices.

13 ALARM VERIFICATION

The Simplicity now includes an option to use alarm verification.

It is intended for use in apartments, and similar buildings, where it is desirable that an alarm from one apartment (or area) would need to be confirmed before the whole system goes into alarm.

13.1 How Alarm Verification Works

The verification function works as follows:-

1. Any SMOKE detector on the system can be set to verify an alarm.
2. If a detector with the verification setting senses smoke, the detector alarm led will turn on. If the detector has an associated sounder base, the sounder will turn on with the Alert tone (i.e. pulsed) rather than the Evacuate tone. The Simplicity panel's screen will show "Confirming alarm" and the PRE-ALM LED will start flashing.
3. If the detector drops below the alarm level within the programmed verification time (30 seconds to 3 minutes 45 seconds), the sounder will turn off and the PRE-ALM LED will turn off, but the panel will continue displaying "Confirming Alarm" for at least 5 minutes. The buzzer will also continue to operate as long as the "Confirming Alarm" message is displayed.
4. If the detector stays in alarm by the end of the verification delay, the system will go into full alarm.
5. If another detector WITHOUT verification setting or a call point goes into alarm, the panel will go straight into full alarm.

With this method of operation a "cooking alarm" in one apartment will alarm locally, giving the apartment occupants a chance to clear the smoke before the whole building is evacuated. Also, as a "failsafe", if a heat detector alarms, or if a second smoke detector on the system goes into alarm, the system will go into full alarm.

13.2 Setting the Alarm Verification Delay

To set the verification delay, go to Configuration menu 2 and select option 6 System menu.

From the system menu, select option 4 (timing)

From the alarm timing screen, select option 2 (Alarm Verify)

Use Prev & Next to adjust the time, then press enter to confirm

```
System Menu
1: Clock   4: Timing
2: Zones  5: Misc
3: Alarms 6: Reset
```

```
Alarm Timing
1: Zonal to Common
2: Alarm Verify
```

```
Detector Verify Time
0:30

ENTER to Confirm
```

13.3 Applying Alarm Verification Delay to a detector

To set the verification delay for a detector, go to Configuration menu 2 and select option 5 (Edit Device)

Scroll to the required device, then press V for Verification. The letter V appears in the top right hand corner to confirm that this device now has the verification delay. Pressing "V" again will toggle the Verification off.

```
Optical V 🔊
Analog: 25 Normal
Fl 3 Bedroom 303
Zone:01      Ad:016
```

14 RESTORING THE PANELS DEFAULT SETTINGS

Because the simplicity now allows several configuration changes, we have also included an option to reset the panel back to its default operation. From Configuration Menu 2, Select Option 6 (Configure System).

System Menu
 1: Clock 4: Timing
 2: Zones 5: Misc
 3: Alarms 6: Reset

Then from the System Menu, Select option 6 (Reset). This brings up the screen to select to reset :-

- * Event Logs
 - * Zones
 - * Panel
 - * Devices
- Or
- * All

Reset Settings
 1: Logs 4: Devices
 2: Zones
 3: Panel 6: All

The panel can be reset in sections, or completely as follows:-

Option	Item	Function
1	Logs	Clears event log (Note that the Event counter is not reset)
2	Zones	Sets the zone boundaries back to their default setting
3	Panel	Resets alarm response back to all common & resets system timers
4	Devices	Clears device information from memory, and clears device label & device configuration
6	All	Performs (2),(3),(4) in one operation

When you select to reset a section, the panel will display something like:

Clear Event Log

 ENTER to Continue

Press enter to confirm, or cancel to abort the action. The panel will then warn that this action cannot be undone.

Clear Event Log
 WARNING: This Action
 cannot be undone
 ENTER to Continue

Press enter to confirm, or cancel to abort the action. The panel will then ask for the Write protect button to be pressed. To Press the write enable button, the panel door will need to be unlocked, providing that extra level of security against accidental erasure.

Please press the
 Write-Enable switch
 on the CPU board

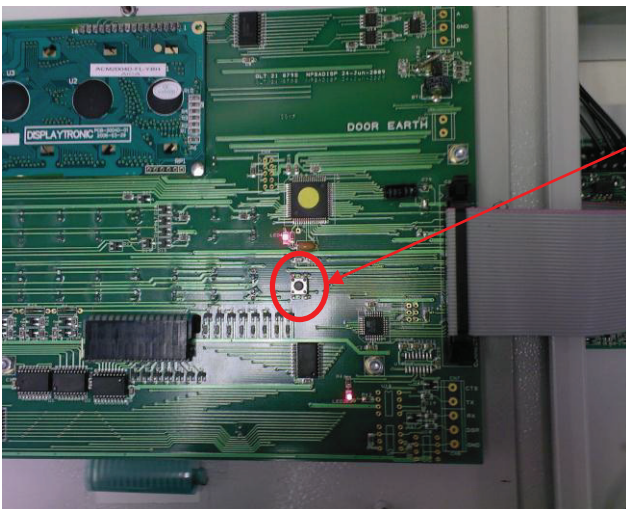

NOTE: Selecting Reset ALL will perform a factory reset on the panel, and will set the protocol to Fyreye MK II.

If the system was running Original Protocol devices, the protocol would need to be set to STANDARD protocol before the panel will see the devices. See Section 12.12

15 VIEWING PANEL INFORMATION

15.1 Menu Structure

To help locate the different features available, the menu structure of the simplicity panel is shown here.

MENU LAYOUT			
MAIN MENU	SUB MENU 1	SUB MENU 2	DESCRIPTION
CONFIGURATION MENU 1 – THE USER MENU			
1:Loop Contents	-	-	View quantity of each device type configured on the loop
2:Device Status	-	-	View the status of an individual device (Status – normal/fault/alarm, Analogue value, device label)
3:Event logs	VIEW EVENT LOG		
	1: Alarms	-	View all fire alarm events
	2: Faults	-	View all fault events
	3: System	-	View all other events (eg keyswitch on, menu access, clock change, etc)
	4: All	-	View all events
CONFIGURATION MENU 2 – THE ENGINEER MENU			
4:Configure Loops	-	-	Configure the loop
5:Edit Device	-	-	Edit device label (press enter for cursor) Turn on detector LED Ring associated sounder Select alarm verification Turn off associated sounder at this address Disable this device. Select specific I/O Operation for an I/O unit
6:Config System	System Menu		
	1: Clock	-	Adjust time & date
	2: Zones	-	Change zone boundaries
	3: Alarms	Alarm Operation	
		1: Det	Choose detectors to cause zonal alarm or common alarm for sounders
		2: MCP	Choose MCP to cause zonal alarm or common alarm for sounders
		3: SOUNDER	Select if the sounders have a zonal to common time out when triggered zonally
		4: Bases	Select if associated sounder bases work common or zonal
		5: I/O	Select default I/O type
	4: Timing	Alarm Timing	
		1: Zonal to Common	Select the delay for all the sounders to operate after a zonal alarm
		2: Alarm Verify	Select alarm verification time
	5: Misc	Misc Settings	
		1: Language	Select LCD language
		2: Version Info	Displays the firmware versions
		3: Protocol	Select device protocol
	6: Reset	Reset Settings	
		1: Logs	Erases event logs
		2: Zones	Resets the default zone boundaries
		3: Panel	Resets panel to default alarm & timing settings
		4: Devices	Erases loop contents from memory, clears device labels, resets verification & sounder base settings to default.
		6: All	Resets all configuration settings, but preserves event log.

15.2 Viewing device status

On the Simplicity, all loop devices can be viewed from Configuration Menu 1, or viewed & edited from Configuration Menu 2.

Enter configuration menu 2 as described above, and select option 5 (Edit Device)
The following screen is shown

```
Optical
Analog: 25 Normal
Fl 3 Bedroom 303
Zone:01 Ad:016
```

The screen is divided into the following sections:-

Configured Device Type

This shows the Device that was at this address during the last loop configuration.
There are 8 possibilities for this:-
Optical, Ion, Heat, Call-Pt, Sounder, I/O Unit, Zone Mon or CO

```
Optical
Analog: 25 Normal
Fl 3 Bedroom 303
Zone:01 Ad:016
```

Analogue Value

This shows the analogue value that the device is sending To the panel. For detectors, this value is usually about 25 for clean air, and 55 during alarm. Non analogue devices such as call points and I/O units have a normal value of 16, and an alarm value of 64. They will return a value of less than 8 to report a fault condition.

```
Optical
Analog: 25 Normal
Fl 3 Bedroom 303
Zone:01 Ad:016
```

Device Status

This is the current status of the device. It will show one of the following values:-
Normal, Fault, Alarm or Prealarm

```
Optical
Analog: 25 Normal
Fl 3 Bedroom 303
Zone:01 Ad:016
```

Fault Description

If the device is in a fault condition, a description of the fault will appear here. It will show one of the following messages:-

```
Optical Changed
Analog: 25 Fault
Fl 3 Bedroom 303
Zone:01 Ad:016
```

FAULT	MEANING
Changed	The device had been changed with one of a different type since last configuration. The message will flash between Changed, and the new type of device seen (eg. Ion).
Missing	The device is not communicating (ie removed , damaged or Address setting changed)
Side A Only	There is a break in the cable, and the device is only seen from Side A
Side B Only	There is a break in the cable, and the device is only seen from Side B
2-ADDR	Two devices have the same address setting
No message	This device is signalling an internal fault by returning a value of less than 8. (EG sounder control unit that has lost it's power supply.)

Device Label

This is the 20 character description of the device location entered by the installer. To change this Press Enter button to activate the cursor.

```
Optical
Analog: 25 Normal
Fl 3 Bedroom 303
Zone:01 Ad:016
```

Device Identification

This is the Zone and address of the device. This is how the device will probably be referred to on the system drawings.

```
Optical
Analog: 25 Normal
Fl 3 Bedroom 303
Zone:01 Ad:016
```

15.3 Locating a device

From the edit device screen, it is possible to send commands to individual devices to start their sounder, or to turn on their alarm LED.

Select the loop and address for the device to be checked.

If the device is an addressable detector, its LED can be turned on by pressing the TEST SELECT Button. A star will appear in the top right hand corner to show that the LED has been lit on this device. Press again to turn off.

```
Optical
Analog: 25 Normal
Fl 3 Bedroom 303
Zone:01 Ad:016
```

If the device is an addressable sounder, or a detector with an associated sounder

base attached, the sounder can be started by pressing the TEST button. The Outline sounder Symbol turns solid to show that the Sounder is active. Press again to turn off.

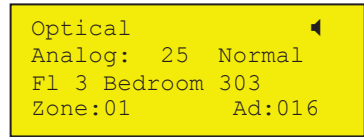

The LED & sounder can both be activated if required.

Scrolling to another device or exiting the menu will automatically turn the LED or sounder off.

15.4 Using the event log

The Simplicity has a 2048 entry event log. In the event of the log being full, it will wrap around, and overwrite the earliest entries. The event log can be viewed through Configuration Menu 1 by selecting Option 3 - View Event Log. The screen prompts for which events to display: Alarms, Faults, System or All.

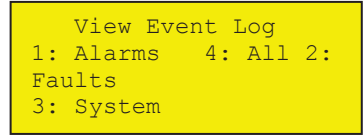

Alarms

If the alarm option is shown, only alarms will be displayed. The screen will show the event number, the date, the time, the type of event (in this case, a DEVICE ALARM), and the Zone, loop and address. Next & Previous buttons will cycle through the list.

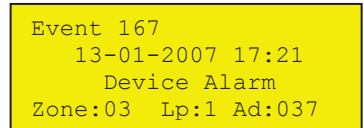

Faults

Selecting this option will display all the faults recorded on the system, Both device faults and general faults. The screen will show the event number, the date, the time, the type of event (in this case, a DEVICE CHANGED fault), and the Zone, loop and address, if appropriate. Next & Previous buttons will cycle through the list.

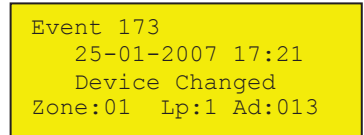

System.

The Simplicity also records other non critical items, such as keyswitch turned on etc. These can be used to help determine the chain of actions before or after an event.

The type of events recorded are:- Power On/Startup, Panel Reset, Evacuate, Keyswitch ON, Keyswitch OFF, Sounders Silenced, Configure Loops, Time & Date Set, Zone Disabled, Zone Enabled, Device Disabled, Device Enabled, Zone Test Start, and Zone Test Finish.

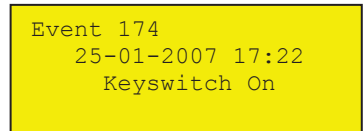

Note: during installation and commissioning, it is possible to create a large number of events, especially if a configured loop is disconnected. This is normal, and is not a case for concern. These events can be cleared, using Configuration Menu 2.

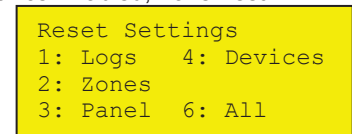

To clear the event log, go to Configuration Menu 2 and select option 6 (Configure System). Select Option 6 to go to the reset screen. Choose option 1 to reset event log.

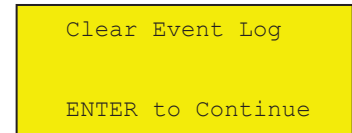

The screen warns that this can not be undone. Press ENTER to clear the event log, or any other button to cancel this screen. It will also prompt for the write enable switch to be pressed.

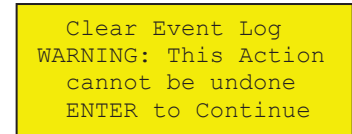

Note that when the event log is cleared, the EVENT NUMBER remains the same. This is so that a visiting engineer will have an idea of the activity on a panel, even if the event log has been cleared. The counter has a maximum value of 524287, and will return to 0 after this.

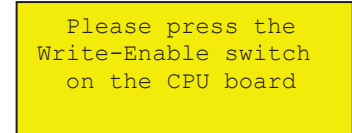

16. THE FIRE ALARM CONDITION

16.1 Viewing a fire alarm event

The way the simplicity panel shows fire alarm information has been changed slightly from previous versions of the panel. The LCD screen text has been altered to show the first & last zone entering the alarm condition.

For Example, a first alarm on a system will bring up the display:

```
FIRE           First Z01
1 of 1
Managers Office
Zone:01       Ad:001
```

This Means there is a fire alarm condition. It is the first (and only) alarm that has Occurred (Fire 1 of 1) The device signalling alarm is in the Manager's office, and It is address 001 in zone 01.

If a second fire then occurs in say zone 2, the system would display:

```
FIRE           First Z01
1 of 2         Last Z02
Managers Office
Zone:01       Ad:001
```

The bottom 2 lines will still show the details of the first alarm (Press Prev or Next to Display information about the second alarm). The top right hand corner shows the first zone that gone into alarm, and the last NEW zone that has gone into alarm. Note that the numbers in the top left corner (1 of 2) is the number of DEVICES in alarm, not the number of zones in alarm. The ZONAL LEDES will indicate the number of zones in the alarm condition.

```
FIRE           First Z01
2 of 2         Last Z02
Kitchen
Zone:02       Ad:017
```

So for example, if there was a third alarm, this time from zone 1 again, the right hand corner would continue to show First alarm ZONE 1, Last alarm ZONE 2. This allows the fire brigade to see the spread of the fire.

```
FIRE           First Z01
1 of 3         Last Z02
Managers Office
Zone:01       Ad:001
```

Because of this, if there are multiple alarms, they are grouped by zone, so scrolling to review alarms would show all alarms in the first zone in alarm, then all alarms in the second zone that went into alarm etc. To view the alarms chronologically, the event log must be used.

16.2 Viewing Faults during a fire alarm condition

In the event of multiple alarms, and multiple faults on the system at the same time, the LCD screen will give priority to alarm events. The screen will show the first alarm, and the Prev/Next scroll buttons will cycle through alarm events only.

The LEDs will show general fault information. To show fault event details on the LCD screen, press the CANCEL button. Prev & next will now scroll through the faults. Press cancel to return to viewing the fire alarm information. (If the panel is left viewing a fault, after a short period of inactivity, the panel will revert to the fire alarm display)

16.3 Viewing Zone Disablements during a fire alarm condition

Zone disablements are indicated by a LED for each zone.

If no individual devices are disabled, then by pressing the GENERAL DISABLEMENT button and the disablement SELECT button, information about zone disablements and the number of individually disabled devices per zone can also be viewed on the LCD.

If one or more devices are disabled, then when the GENERAL DISABLEMENT button is pressed, the screen will display the options as shown in section 17.4. Press 1 to select zone disablements, and then continue as per the paragraph above.

16.4 Viewing Device Disablements during a fire alarm condition

To view individual device disablements during an alarm condition, press the GENERAL DISABLEMENTS button, and the screen will display the options as shown in section 17.4. Press 2 to select device disablements, and press the Next button to scroll through all the disabled devices.

16.5 Viewing Zones in Test Mode during a fire alarm condition

On the simplicity panel, zone test mode is indicated by a LED for each zone, so LCD screen access is not required.

17. DISABLEMENT

On the Simplicity, there are 2 disablement options. A whole zone of devices can be disabled, or an individual device in a zone can be disabled. Both types of disablement can be used at the same time if required.

Note that when there is any type of disablement present, line 3 of the “System Normal” screen will show “Disablements Present”.

```
SIMPLICITY 252
FIRE ALARM PANEL
Disablements Present
27-09-2010 15:16
```

Also note that any required disablement(s) must be programmed before a zone is put in to test mode.

17.1 Zone disablement

To aid commissioning and assist routine maintenance checks, any of the zones or the loop sounders can be disabled.

When a zone is disabled, the panel will not respond to any fault or fire signals it receives from any device in that zone.

This might be used if the system requires routine maintenance, and the customer needs the system to continue running, but doesn't want spurious false alarms.

The panel will respond in the usual manner to any events in any non-disabled zones.

The Simplicity also allows the loop sounders to be disabled. If they are disabled, the panel will not start any sounders in an alarm condition.

17.2 To programme zone (or sounders) as disabled

Any number of zones (or the sounders) can be disabled, but it is good practice to only disable one zone at a time.

1. Insert and turn control key to enabled position;
2. Press GENERAL DISABLEMENT button and the screen will show: ZONE DISABLEMENT ZONE 1. The panel is now in SELECT DISABLEMENT MODE.
3. Press DISABLEMENT SELECT until the required zone or loop sounders is DISPLAYED. Press DISABLEMENT CONFIRM button. The screen will now show that the zone is disabled, and the Zone or Sounder LED will come on steady, along with the GENERAL DISABLEMENT LED. This section is now disabled. **(NOTE: Call points in this zone will also be disabled. To keep the call points functioning, disable the detectors in that zone individually as devices – see 17.3)**
4. If more than one zone (or sounder) needs to be disabled, then press DISABLEMENT SELECT again until the required zone (or sounder) is selected.
5. If the panel needs to be taken out of SELECT DISABLEMENT MODE (eg to silence a fault on another part of the system), Either press GENERAL DISABLEMENT button, or turn the keyswitch off, then back on again.
6. Once all the maintenance work has been done the zones need to be enabled again. If the panel is still in SELECT DISABLEMENT MODE, jump to paragraph 7, otherwise, turn the keyswitch to controls enabled, press GENERAL DISABLEMENT button. The panel is now in SELECT DISABLEMENT MODE
7. Press the DISABLEMENT SELECT button until the disabled zone is displayed on the screen. Press DISABLEMENT CONFIRM button to de-select disablement. Scroll to any other disabled zone and enable in the same way. When all zones are enabled again, the GENERAL DISABLEMENT LED will turn off. Turn the keyswitch to off position to return the system to normal. (NOTE: This will also enable any points individually disabled in that zone)

```
Zone Disablement
Zone 1
Zone Enabled
Disabled Devices: 0
```

```
Zone Disablement
Zone 3
Zone Disabled
Disabled Devices: 0
```

17.3 Device disablement

The Simplicity Plus panel can also disable individual devices (detector, call point, sounder or interface). To do this, enter CONFIGURATION MENU 2 and select EDIT DEVICE. Select the required device, then press GENERAL DISABLEMENT button. The Device label now flashes between the programmed label and Device Disabled. The general disablement LED will also be lit. This device is now disabled.

```
Optical
Analog: 25 Normal
Device Disabled
Zone:01 Lp:1 Ad:016
```

To re-enable the device, press the disable button again. Note that when all the devices in a Zone are disabled, the Zone is considered to be disabled, and the Zone disablement LED will light.

17.4 Viewing disablements

When disablements have been programmed (either zone or device), the general disablement LED will be lit. To view the disablements, press the GENERAL DISABLEMENTS button, and the screen will show the following:

```
Disablement
1: Zones
2: Devices
```

17.4.1 VIEWING DISABLED ZONES

To view which zones are disabled, press 1 and then scroll through all the zones, by pressing the disablement Select button or the Next button

If a zone is not disabled, the screen will show

```
Zone Disablement
Zone 1
Zone Enabled
Disabled Devices: 0
```

If a zone is disabled, the screen will show

```
Zone Disablement
Zone 1
Zone Disabled
Disabled Devices: 0
```

If there are one or more disabled devices in a zone, the screen will show this by the number of Single Devices as follow.

```
Zone Disablement
Zone 1
Zone Enabled
Disabled Devices: 2
```

(TIP: a quick way to enable several disabled devices is to disable the zone in which these devices are located, then re-enable it)

17.4.2 VIEWING DISABLED DEVICES

To view which devices are disabled, press 2 and scroll through all the disabled devices, by pressing the Next button.

The screen will show:

Line 3 will flash between the device label and Device Disabled Message.

```
Optical
Analog: 25 Normal
Device Disabled
Zone:01 Ad:016
```

18. TEST MODE

18.1 Why use test mode

To aid commissioning and assist routine maintenance check, a silent, non-latching 'one man test' facility is available.

When a detector or manual call point is triggered on any zone in Test, the Device will light it's LED, When the smoke has cleared, or the call point has been reset, the LED will turn out.

Should an Alarm occur on a zone that is not programmed to test, the Fire Alarm Panel will go into full alarm. The Zone test LED will continue to be lit. When the alarm has been reset, test mode will resume

18.2 To programme zone in test mode

NOTE: Only **one zone** can be programmed in test at any one time.

1. Insert and turn control key to enabled position;
2. Press TEST Button. The screen will prompt for the test code
3. Enter the Test code **2 4 8**.
4. The screen will now invite you to select the zone to be tested, as follows:

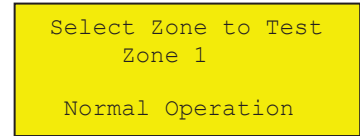

5. Press TEST FUNCTION SELECT button to select the zone to be tested.
6. Press CONFIRM to enter test mode for this zone
The General Test and Zone Test LEDs will now be lit.
7. Detectors in this zone can now be tested with smoke spray. The Detector will light it's LED until the smoke clears, then it will reset. The Sounders & the fire relay are not operated during test mode.
8. Once testing of that zone is completed, press TEST FUNCTION SELECT button to move to another Zone or turn the control key switch to off position to exit test mode.

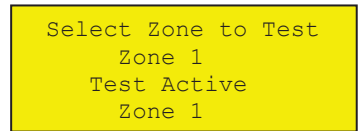

18.3 To program sounder circuits in test mode

1. Insert Control Key and turn key to enabled position;
2. Press General TEST Button, The screen will prompt for the test code.
Enter the code 2 4 8.
3. The screen will now show Test Mode, Zone 1, Normal Operation.
4. Press TEST FUNCTION SELECT button several times to select the Loop SOUNDERS.
5. Press confirm to enter test mode for this function. The general test LED and the sounders test LED will now be lit.
6. The Sounders will now pulse 8 seconds on, 8 seconds off until they are taken out of test mode. This allows all the sounders to be tested for correct operation, and dB output.
7. Once testing of the loop sounder circuit is completed press CANCEL or turn the control key switch to off position to exit test mode.

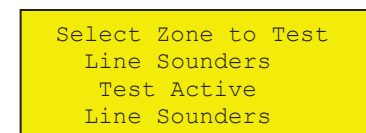
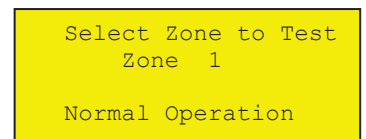

19. GENERAL FAULT FINDING

On the Simplicity panel, Faults are divided into 2 types, "Faults" and "Device Faults". Device Faults are any fault associated with a particular address on the loop. Faults are everything else, EG , power supply etc. In the event of multiple faults, the Faults are grouped together first, followed by the device faults. Next button will scroll to next fault.

19.1 Common fault

This is a general indicator which lights whenever a fault is present. It doesn't refer to a specific fault.

19.2 Loop contents fault finding

If the loop contents are different to what was expected, then there three probable causes:-

1. Two or more devices may have the same address setting. This is referred to as a double address fault. If this occurs all devices with the same address will answer at the same time. The panel will not be able to understand the answer it receives. **NOTE: If a panel detects a double address, it will light the LEDs of the devices with the problem. (NOTE: only detectors will light their LED. Sounders & interface modules will not be indicated).**
2. There may be some reversed connections to devices (they are polarity sensitive). The Fyreye detectors should be connected Loop + to L2, loop – to L1IN. Other devices will have their polarity marked by their connections.
3. On the reduced loop Simplicity panels (ie Simplicity Micro & Simplicity Plus 64), it is possible to address a detector out of the panels range (eg a Simplicity Plus 64 would not read a detector set to address 65, but it will now report a device out of its address range to help identify this problem)

If the panel reports any double addresses present, investigate these first as they are the easiest to find. The panel will turn on the LED of any incorrectly addressed detector. (See 19.6 DOUBLE ADDRESS)

If there are still less devices than expected, check the missing addresses for correct wiring polarity. If in doubt, contact your supplier.

If the wiring polarity is correct, check that there is no cable break on the loop. (If there is a break, the panel will report the break after 60 seconds or so, and inside the panel, the LOOP POWERED LEDs (on the termination PCB) will alternate on & off). Some devices take a few seconds to power up, so may show as missing during the repeated Power Down / Power Up cycle that occurs during a line break.

19.3 Zone faults

There are several reasons for the zone fault LED to light.

1. There is a cable break, or short circuit to devices in that zone,
2. A device has been removed from that zone
3. A device has been changed for one of a different type
4. There is a double address in this zone (see previous section)
4. A device in that zone is communicating a fault condition to the panel with its analogue value. A value less than 8 is usually a fault condition. (This could be a zone monitor reporting a fault in its zone wiring, for example.)

The LCD will show Device Fault, the user label, and the address of the fault. Pressing enter will bring up the View Device screen for the device showing fault. This will give more information about the fault.

```
*** Device Fault ***
      1 of 1
Floor 1 Room 101
Zone:01      Ad:001
```

In this example, the device is Missing. IE the panel is not receiving an answer from this address. This could either be a removed detector, a changed address switch setting, or a damaged detector. Check the device has not been removed. Check that there is power to the base. Check address hasn't been changed (compare to system set-up chart). Check that the base contacts are clean and free from dirt & corrosion. If possible, try a replacement head (remembering to set the correct address)

```
Optical Missing 
Analog: 00 Fault
Floor 1 Room 101
Zone:01      Ad:001
```

19.4 Supply faults

This version of the simplicity panel uses a separate power supply, so individual Fault indications are not available on the LCD.

To locate the cause of the supply fault, open the panel door, and check the LED indications on the Power Supply Board

The Power supply will have LED indications for:-

Mains Fail (Mains low or missing)
 Battery Fail (battery low, battery missing, battery high impedance)
 Charger fail
 Earth fault (can be disabled if earth fault monitored by panel)

```

***  FAULT  ***
      1 of 1
Supply Fault
  
```

19.5 Earth faults

An EARTH fault indicates that something is shorting to earth (usually through the cable screen). Disconnect the earth screens one at a time to determine the problem line.

(Note: connecting other equipment , eg an oscilloscope or a PC , to the panel can give an earth fault)

The Screen will indicate if it is a Positive or Negative voltage shorting to earth (Earth Fault Pos or Earth Fault Neg).

*****DO NOT DISCONNECT THE MAINS EARTH CONNECTION. THIS WILL CAUSE A PROBLEM WITH THE PANELS OPERATION*****

```

***  FAULT  ***
      1 of 1
Earth Fault Pos
  
```

19.6 Double address

This indicates that a double address has been detected. This usually happens during initial setup, where 2 detectors are given the same address, or if a head is replaced during maintenance, and its address has been wrongly set. In the second scenario, the panel will report 2 fault addresses, one will be the double address, and the other will be a missing device. As a further aid to finding the fault, the panel will light the LEDs of any detectors with a double address (Sounders & I/O units will not be indicated as they have no panel controlled LED to light up)

1. Make a list of the double addresses reported (there may be more than one).
2. Go to view device screen in Configuration menu 1. Scroll through the devices, and make a list of any that are missing (**Note:** the panel skips over empty addresses when scrolling)
3. Go to the location of the missing device, and check if it has its LED on (Detector), or check the dip switch setting.
4. If this does not cure all double addresses, go to the known location, and temporarily remove the device. The panel will now report the type of device that was also configured to this address from the view device screen. This will help narrow down the search for the device. (eg if extra device is call point, check the address settings of all the call points)

19.7 System fault

A system fault is an abnormal microprocessor running condition due to various unexpected phenomena.

This will result in the panel attempting to correct itself. Should this fault occur, the System Fault LED, General Fault LED, General Fault relay and fault internal buzzer will be constantly active until the control keyswitch is turned from off position to control enable position. This should cause this fault condition to reset. If not, consult your supplier.

19.8 Pre-alarm

This is not a fault condition. The panel has detected a high reading from one of the devices on the loop. This could be caused by a fire starting (in which case it acts as an early warning), or it could be caused by a contaminated head. The panel will report the location of the problem device, which should then be investigated.

The PRE-ALM LED is illuminated constantly during the pre-alarm condition. **Note that the same LED is used during the confirmation period of Alarm Verification (see section 13), but in this case the LED flashes.**

19.9 Sounder faults

On the Simplicity there are only loop controlled sounders, but there may be conventional sounder circuits connected via a ZSCC

Sounder circuit controllers (ZSCC).

Check :-

- Check that the correct END of Line resistor is fitted. (47K – Yellow, purple, orange, gold)
- Check that the sounder fuses is OK (FS1, – 4000mA TD)
- If working on an existing installation, check that the devices are **polarised**. (See Page 5)
- Check cable continuity (remove from panel and measure continuity. Should read 47K)
- Check its external power supply is connected & working

For loop powered sounders, check that all sounders are communicating, and check their analogue value. If a sounder is returning a value less than 8, then it has detected an internal fault and should be replaced. If they are not communicating, then check that they have power, and that the power is connected the correct way. If they have power, they may be damaged. Try a replacement if available.

Note that common sounder bases, and associated sounders are only monitored through the cable continuity (similar to a conventional sounder circuit), so are not able to give any fault messages.

19.10 Loop wiring faults

A loop fault can be caused by a break, or short circuit in the Loop wiring. Open the panel and look for the 2 LOOP ON LEDs on the termination PCB. (4 LEDs for a 2 loop Simplicity). Under normal conditions these should be all lit steady. The LEDs represent Loop1 Side A and Loop 1 side B, and Loop2 Side A and Loop 2 side B.

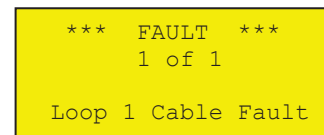

If both loop LEDs for a loop are off, then this indicates that there is a short on the loop that the isolators couldn't bypass. (Check that the isolators are enabled, and aren't set for a cable continuity check). Split the loop half way, and check if either side of the loop will power up. Continue making more splits until the short has been found.

If the LEDs for a loop are flashing (both on, side A only, both on, side B only etc – monitor for 12 or so seconds to see if LEDs flash), then this indicates a break in the wiring. This could be caused by either a break, or a pair of isolators shutting down a short circuit. If there are several missing devices (wait for the zone fault LED & check the addresses in that zone), then there is probably a short circuit on the loop (look for isolators lit Yellow or flashing). The missing devices should give an indication of the section with the break. Investigate that section as per the dead short circuit fault tracking method, as described above.

If there are no missing devices, then there is probably a simple break. If the loop has been configured such that as you move down the loop, the address always increases, then the fault can be located through the menu.

Go to view device screen. And select the first device on the loop. The screen will say either Side A only or Side B only. Scroll through the loop. When it changes from Side A only to Side B only (or Vice versa), this should be the location of the break.

Alternatively, disconnect one side of the loop and check which devices can be read. The break should be after the last read device. (Take care to keep the removed cables away from the panels circuit boards.)

20. STANDBY BATTERY REQUIREMENTS

The Following Table shows the Quiescent, Fault & alarm currents of the main parts of a Simplicity Fire Alarm System

Device	Product Code	I _q (mA)	I _{fit} (mA)	I _{alm} (mA)	Max per Loop	Max per System
SIMPLICITY PLUS 64 Fire Alarm Panel	SP-64	90	105	115	N/A	1
SIMPLICITY PLUS 126 Fire Alarm Panel	SP-126	90	105	115	N/A	1
SIMPLICITY PLUS 252 Fire Alarm Panel	SP-252	115	120	130	N/A	1
Premier Addressable REPEATER PANEL	REP-AD	200	220	220	N/A	4*
Fyreye Extra Addressable Optical Smoke Detector	FEAOE2000	0.48	N/A	2.3	126	252
Fyreye Extra Addressable Heat Detector	FEAHE2000	0.44	N/A	2.4	126	252
Fyreye Extra High Temperature Heat Detector	FEAHE2000	0.44	N/A	2.4	126	252
Fyreye Extra Addressable Opto-Heat Detector	FEAOH2000	0.52	N/A	2.3	126	252
Zeta Addressable Call Point (EN54)	ZT-CP2/AD	1	N/a	2.9	126	252
Zeta Weatherproof Addressable Call Point	ZT-CP2/AD/WP	1	N/a	2.9	126	252
Zeta Input Unit	ZIU	0.9	2.8	2.9	126	252
Zeta Input Output Unit	ZIOU	0.9	2.8	10.6	16	32
Zeta Input Output Unit – mains switching	ZIOU/230	0.9	2.8	19	10	20
Zeta Sounder Control Module	ZSCC	0.9	2.8	10.6	16	32
Zeta Sounder Control Module – 4 circuits	ZSCC/4	0.8	1.09	0.8	16	32
Zone Monitor Unit	ZTSM/1	1.08	1.09	1.09	10	20
Zone Monitor Unit – 4 zones	ZTSM/4	1.08	1.09	1.09	10	20
Zeta Loop Powered Door Magnet interface	ZTA-DH	1.0	3.0	16.6	12	24
Fyreye Addressable Beam Detector (5-50m)	ZT-50RA	5	7	9	20	40
Fyreye Addressable Beam Detector (50-100m)	ZT-100RA	5	7	9	20	40
Zeta Addressable Common Sounder Base	ZTA-CSB	0.4	N/a	4.0	64	128
Zeta Addressable Common Sounder Flasher Base	ZTA-CSFIB	0.7	N/a	5.5	48	96
Zeta Addressable Maxitone Sounder	ZAMT	0.6	N/a	12	32	64
Zeta Addressable Maxitone Sounder flasher	ZAMTF	0.6	N/a	15	24	48
Zeta Addressable Securetone 2 Sounder	ZAS2/R	0.5	N/a	4.0	64	128
Zeta Addressable Securetone 2 Sounder Flasher	ZAS2/RFI	0.9	N/a	5.5	48	96
Zeta Addressable Remote LED Indicator	ZTA/LE2	1.5	N/a	10	32	64
Zeta Addressable 3 wire Remote LED	ZTA/LE3	0	N/a	10	32	64
Conventional Sounders (via a sounder Control Circuit)						
Zeta Conventional Maxitone Sounder	ZMT/8	0	N/a	15	N/a	N/a
Zeta Conventional Miditytone Sounder	ZMD/8	0	N/a	15	N/a	N/a
Zeta Conventional Securetone Sounder	ZST/8	0	N/a	15	N/a	N/a
Zeta Conventional Megatone Sounder	ZIDC	0	N/a	200	N/a	N/a
Zeta Conventional Flasher	ZFL2RR	0	N/a	90	N/a	N/a
Zeta Conventional Sounder Flasher	ZLT/8RR	0	N/a	110	N/a	N/a
Zeta Conventional 6" Bells	ZTB6B/24	0	N/a	25	N/a	N/a
Zeta Conventional 8" Bells	ZTB8B	0	N/a	35	N/a	N/a
Conventional Detectors (via a Zone Monitor)						
Fyreye Conventional Optical Detector	FEO2000	0.06	N/a	25	N/a	N/a
Fyreye Conventional Heat Detector (A1R)	FEHR2000	0.04	N/a	25	N/a	N/a
Fyreye Conventional Heat Detector (CS)	FEFH2000	0.04	N/a	25	N/a	N/a
GSM COMMUNICATOR	GSM-COM	200	500	500	N/A	1
TCP-IP COMMUNICATOR	TCP-IP	80	80	80	N/A	1

* The Simplicity can only power 1 repeater. Any subsequent ones will need a separate power supply.

20.1 Standby battery calculation

In order to calculate the standby battery size required, the following formula can be used:-

$$\text{Battery Size (Standby time in Amp Hours)} = 1.25 \times [(T_{\text{ALM}} \times I_{\text{ALM}}) + (T_{\text{SBY}} \times (I_{\text{QP}} + I_{\text{QZ}}))]$$

Where:

- T_{ALM} = Maximum time in hours required for the alarm [$\frac{1}{2}$ hour is most common time]
- I_{ALM} = Total Alarm Current in amps for all alarm devices connected to the alarm circuits
- T_{SBY} = Standby time in hours for the system after mains failure [normally 24, 48 or 72 hr]
- I_{QP} = Quiescent current in amps of control panel in fault condition [because of mains failure]
- I_{QZ} = Quiescent current in amps of all detection zones. Eg Addressable optical detector 0.00048 Amp (480 μ A)

Typical Example:

A system comprises of 80 Addressable Optical detectors, 30 Sounder bases and the required standby is 24 hours. It will need to operate in alarm for $\frac{1}{2}$ hour.

Calculate the battery size required.

$$T_{\text{ALM}} = 0.5 \text{ Hr}$$

$$T_{\text{SBY}} = 24 \text{ Hr}$$

$$I_{\text{QP}} = 0.105 \text{ A (Quiescent current for panel)}$$

$$I_{\text{QD}} = 80 \times 0.00048 = 0.0384 \text{ A [the quiescent current for an Addressable Optical detector is 480 } \mu\text{A]}$$

$$I_{\text{QS}} = 30 \times 0.0004 = 0.012 \text{ A [the quiescent current for an Addressable sounder is 400 } \mu\text{A]}$$

$$I_{\text{Alm-snd}} = 30 \times 0.004 = 0.12 \text{ A}$$

$$I_{\text{AP}} = 0.115 \text{ A}$$

Therefore using the equation:

$$\text{Battery Size (Standby time in Amp Hours)} = 1.25 \times [(Df \times T_{\text{ALM}} \times (I_{\text{Alm-snd}} + I_{\text{AP}})) + (T_{\text{SBY}} \times (I_{\text{QP}} + I_{\text{QD}} + I_{\text{QS}}))]$$

(DF is a derating factor (typically = 2) used when a battery has to supply a high current load)

$$\text{Battery Size (Standby time in Amp Hours)} = 1.25 \times [(2 \times 0.5 \times (0.115 + 0.12)) + (24 \times (0.105 + 0.0384 + 0.012))]$$

$$\text{Battery Size (Standby time in Amp Hours)} = 1.25 \times [0.235 + (24 \times 0.1554)]$$

$$\text{Battery Size (Standby time in Amp Hours)} = 1.25 \times [0.235 + 3.7296]$$

$$\text{Battery Size (Standby time in Amp Hours)} = 1.25 \times 3.9646$$

$$\text{Battery Size (Standby time in Amp Hours)} = 4.9575 \text{ Amp Hours}$$

This system would require a minimum of 4.96 Ah batteries, so we would recommend using 7Ah batteries (as the enclosure is designed for this size batteries).

21. PCB TERMINATION CONNECTIONS.

21.1 Simplicity plus CIE termination PCB

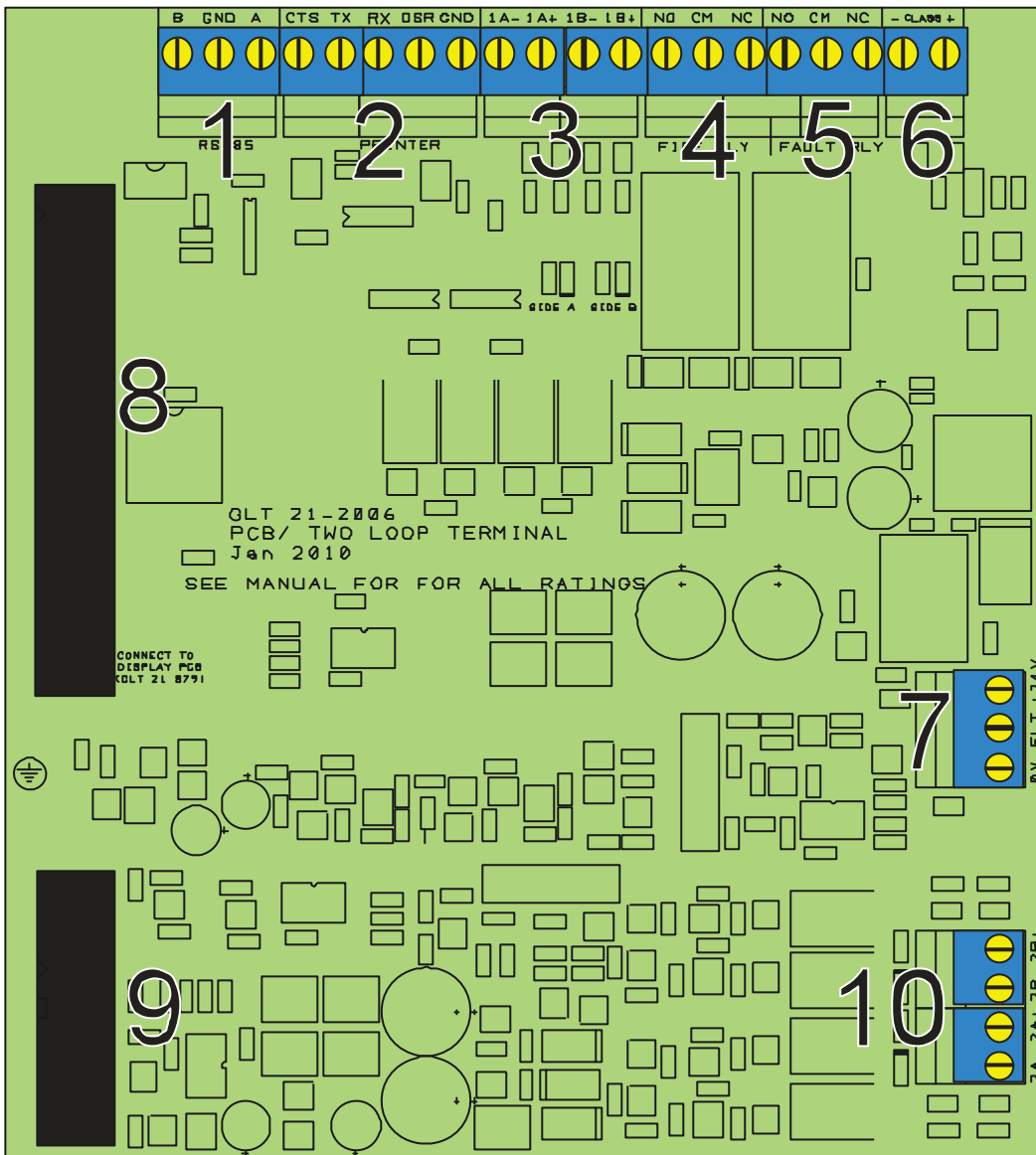

21.2 Connections

Connection No	Description	Use
1	RS 485 REPEATER	To link to addressable repeater
2	RS232 PRINTER	Serial port. Link to printer or TCP-IP reporting module
3	ADDRESSABLE LOOP 1	Connect to detector wiring: loop 1
4	FIRE RELAY	Volt free relay. Operates on any alarm
5	FAULT RELAY	Volt free relay – normally energised. Operates on any fault
6	CLASS CHANGE	Remote input to operate fire alarm panel sounders
7	24V & FAULT FROM PSU	Power & power supply fault connection to power supply
8	34 WAY RIBBON CABLE TO DISPLAY	Connects Loop 1 signals & general signals to display PCB
9	10 WAY RIBBON CABLE TO DISPLAY	Connects Loop 1 signals to display PCB (on 2 loop simplicity only)
10	ADDRESSABLE LOOP 2	Connect to detector wiring: loop 2 (on 2 loop simplicity only)

21.3 Simplicity plus power supply PCB

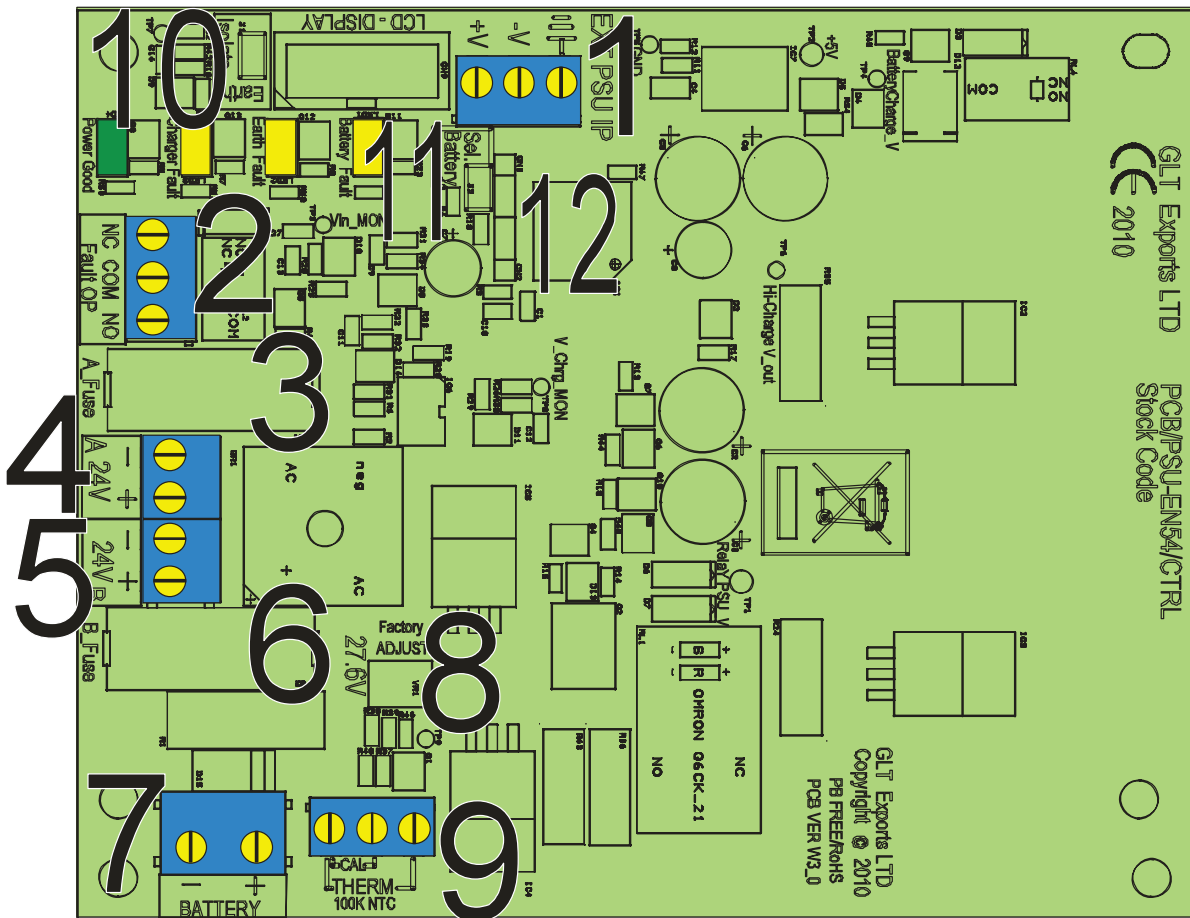

21.4 Simplicity plus power supply connections

Connection No	Description	Use
1	EXT PSU IP	External Power input from Switch Mode cage
2	FAULT OP	Volt free fault relay, normally energised
3	A-FUSE	Fuse for the first 24V output
4	24V A	Connection for the first 24 V output
5	24V B	Connection for the second 24 V output
6	B-FUSE	Fuse for the second 24V output
7	BATTERY	Battery connection. 2 x 12V SLA batteries wired in series
8	FACTORY ADJUST	Charger adjust pot. DO NOT ADJUST
9	THERM	Battery charger temperature compensation thermistor
10	EARTH ISOLATE	Jumper link to enable / disable earth fault reporting
11	SEL. BATTERY	Link to put charger in calibration mode from power up.
12	CN2 / CN3	ISP programming connector

21.5 Simplicity plus power supply fuses

FUSE NO	DESCRIPTION	RATING
IN LINK WIRE	Battery Fuse	5.0A time delay 5 x 20mm glass
FS1	Supply Fuse A	1.0A time delay 5 x 20mm glass
FS2	Supply Fuse B	1.0A time delay 5 x 20mm glass

22 SPECIFICATIONS

22.1 Enclosure specifications

DESCRIPTION	VALUE
ENCLOSURE SIZE	375 x 335 x 125 mm
TOP CABLE ENTRIES	12 x 19mm DIA GROMMETED ENTRIES
BOTTOM CABLE ENTRIES	2 x 19mm DIA GROMMETED ENTRIES
REAR CABLE ENTRIES	2 REMOVABLE CABLE ENTRIES, 60 x 20mm

22.2 Electrical specifications

ELECTRICAL DESCRIPTION	VALUE
MAINS VOLTAGE	230V AC +10% / -15% @ 50/60 Hz
BATTERY VOLTAGE	24V DC (2 X 12V SLA BATTERY)
SYSTEM VOLTAGE	28V DC NOMINAL (18 – 32 V)
SYSTEM VOLTAGE RIPPLE	1V PK-PK MAX
CHARGER SIZE	750mA
LOOP VOLTAGE	28V DC NOMINAL (+9 volt data)
SOUNDER ALARM OUTPUTS	LOOP POWERED SOUNDERS ONLY
AUXILIARY FAULT OUTPUT	1 x FAULT RELAY SELV@1A (NORM. ENERG)
AUXILIARY FIRE OUTPUT	1 x FIRE RELAY SELV@1A
NUMBER OF LOOPS	1 LOOP
MAXIMUM NUMBER OF ZONES	8 ZONES (4 FOR SIMPLICITY 64)
MAXIMUM LOOP CAPACITY	126 DEVICES (64 FOR SIMPLICITY 64)
MAXIMUM ZONE CAPACITY	RECOMMENDED MAX -32 DEVICES PER ZONE
MAXIMUM LOOP RESISTANCE	25 ohms
MAXIMUM LOOP CAPACITANCE	0.3µF
MAXIMUM VOLTAGE PICKUP ALLOWED	50mV
REMOTE SOUNDER ACTIVATION	VIA N/O CONTACTS
CHARGER VOLTAGE	27.6V @ 22-24°C (NO BATTERY CONNECTED)
LOOP SHORT CIRCUIT PROTECTION	750mA
BATTERY DEEP DISCHARGE PROTECTION	Batteries less than 19.7V
TOTAL PSU OUTPUT	2.5 Amp