

VEVOR

Air heater KW2.0 5.0 8.0 Manual

www.vevor.com

Contact: service@vevor.com

Call us:

(+626) 275-4507 (For USA)

(+44) 1173182739 (For Europe)

(+001) 626 275-4507

(For Other Countries)

Working Time:

Mon-Fri 8:00 am to 5:00 pm



Air Heater

Installation Instructions and Manuals caveat

- 1 add gasoline
- 2 After the machine is installed, check whether the phone is stuck, if it is stuck, it cannot be started.
- 3 The red power cord must send out the battery
- 4 After the red power line is connected, you need to check whether the load voltage reaches 1.5V, and there is no need to check the battery or wiring
- 5 After installation, you need to start multiple oil circuit air repairs before you can start the machine normally
- 6 Install the outlet pipe without any bends around, and the outlet pipe should not be bent
- 7 Install the input pipe and the direction of the outlet pipe
- 8 This machine is for domestic use. Please pay attention that there should be no gasoline outside the exhaust pipe. The domestic power supply needs to reach 350W.

D3/D5 diesel oil 12V

Technical specifications and installation

D3/D5 diesel oil 24V

Operation and security maintenance instructions

*Our company is not responsible for any loss or liability caused by the failure to install and use according to Article 1 to 8.

		<p>1.1) Check for oil shortage, frozen or blocked oil pipelines</p> <p>1.2) Check whether the pump is jammed or damaged and the pump is powerless to pump.</p> <p>1.3) Check whether the intake and exhaust passages of combustion are unobstructed</p> <p>1.4) Check whether the ignition plug is damaged</p> <p>④) The ignition is normal but the failure of ignition is still reported.</p> <p>Check whether the housing temperature sensor is in full contact with the housing, whether the pressure spring is strong, whether the sensor is normal.</p>
E-8	sensor failure	Whether the temperature sensor connectors and connectors are damaged or loosened, whether the sensor is damaged or not.

code of use

1. It is prohibited to use in high humidity, conductive dust, flammable and explosive gases, dust, materials, corrosive media, strong light, strong magnetic, high voltage and high current equipment nearby.
2. Voltage range of power supply: DC24V controller is suitable for (18-32) V; DC12V controller is suitable for (9-16) V; different voltage controllers are not universal, and it is forbidden to use beyond the applicable voltage range.
3. The 5KW controller must be used on the 5KW organism; the 2KW controller must be used on the 2KW organism.
4. If the controller or external device is damaged, it must be replaced by the prototype device and professionals.
5. It is forbidden to open the controller shell privately
6. Equipment must be installed strictly and must be used under safe conditions.
7. The company is not responsible for the loss and liability of the controller due to the misconnection short circuit and damage of the external devices and lines.
8. At the high temperature of the body, the fan can not operate, so it must be cooled quickly for the body to make its temperature. Cooling air is injected from the combustion inlet to make the body temperature less than 100 °C. Prevent high temperature from burning parts or causing fire.

Contents

I. Introduction	03
1. Application fields and purpose of heater	03
2. Installation and operation safety instructions	03
II. Product information	04
1. Complete sets of equipment and installation components of heater	04
2. Technical parameters	05
3. Product dimension	05
III. Installation	06
1. Installation position	06
2. Installation angle and fastening	07
3. Installation of combustion air duct and exhausting device	08
4. Installation notes for heating air duct	09
5. Fuel supply	10
IV. Operation and Control Mode	12
1. Fuel filling	12
2. Control mode	12
V. Circuit	12
1. Wiring of heater	12
2. Circuit diagram	12
VI. Fault, maintenance and service	13

I. Introduction

Application fields of heater

The air heater will not be affected by the engine and will be installed in the following vehicles on the premise of following the heating power:

- Various makes of automobile and trailer
- Construction machinery
- Agricultural machinery
- Ships and boats
- RV

Purpose of heater

- Preheating and defrosting the glass
- Heating and insulating the following areas:
 - Cab, working cabin, ship cabin
 - Cargo warehouse
 - Within the personnel or team cabin
 - RV

The heater cannot be applied in the following occasions regarding the regulations for functions:

- Long-time and continuous heating:
- Living room, garage
- Home ship, etc.
- Heating or drying:
- Life (people or animals), IV direct heating mode will be used.
- Item
- Blow hot air to the container

Installation and operation safety instructions

- Setting of heater

Prevent the heater from high temperature or damages.

• exhaust gas system

When the discharge outlet of exhaust gas is placed, it should prevent the waste gas entering the automobile through the ventilation device, inlet of hot air or window.

• Air inlet of combustion air

Do not breathe the combustion air used in heater combustion from the passenger compartment.

When installing the air inlet, note that it should not be blocked by other materials.

• Inlet of heating air

The heating air which is supplied should be composed by the fresh air or recycled air and be drawn from a clean area.

The inlet pipeline should be protected with safety fence or other proper tools.

• Outlet of heating air

When the hot air pipeline is placed in the automobile, it should ensure that it is difficult to be contacted and prevent the personnel or materials from damages.

• Exhaust system

When placing the exhaust pipe, we should note that the outlet of exhaust pipe should avoid the combustibles and prevent heating or burning the ground combustibles or loading cargo.

Safety instructions for installation and operation

The following measures should not be taken:

- Change key parts on heater
- Use the parts of other manufacturers without the company's permission
- Go against the specifications specified in the instructions during the installation or operation.
- It is only allowed to use the original accessories and fittings during the installation or maintenance.
- It is not allowed to use heaters in the place where the flammable vapor or dust may produce.

- Fuel depot

- Carbon storage warehouse
- Wood material warehouse
- granary and similar points

• The heater should be closed when fueling.

• If the fuel flow (discharge) out of the fuel system of the heating equipment, it should be immediately returned to the service provider for maintenance.

• In the working process off hours, it is not allowed to stop heater by powering off.

E-3	Ignition plug failure	1) Check whether the ignition plug connector is loose or the wire is short-circuited to the housing 2) Detect whether the ignition plug is damaged
E-4	Oil Pump Failure	Check for damage, loosening, oxidation, short circuit and breaking of oil pump connections and connectors
E-5	High temperature alarm (intake > 50 C ; case > 230 C)	1) Check whether the heating duct is unobstructed 2) Check whether the fan is working properly 3) Check whether the temperature sensor is normal
E-6	Fault of Fan	1) Check whether the impeller is stuck 2) Check if the connection plug-in is loose 3) Excessive gap between magnet on wind turbine and Hall sensor on controller 4) Whether the line is short-circuit or open-circuit, leakage of motor
	Flameout	1) Check for oil shortage, low temperature solidification of oil, blockage of oil pipeline and blockage of oil pump 2) Check whether the intake and exhaust ducts are unblocked 3) Check whether the housing temperature sensor is in full contact with the housing and whether the pressure spring is strong
E-8	Unsuccessful start up	1) The shell temperature is too high to blow the cooling shell for 3 minutes after starting. 2) There is a lot of white smoke in the exhaust gas 2. 1) Check that the filter beside the ignition plug is clean and not cleaned or replaced 2. 2) Check whether the fuel injection is effective 2. 3) Check whether the ignition plug is aging 2. 4) Is the clearance of the internal wind turbine too large? 2) A small amount of white smoke or no smoke in the exhaust gas

6) Starting Timing Function

At the same time, long press the “*” and “▲” key to start the timing function, start the timing boot in the shutdown state, start the timing shutdown in the boot state, press the C key short to see the remaining time.

6. remote control code-matching operation

In shutdown state, simultaneous long press “○” and “▼” for two seconds, enter remote control code as follows.



- 1) Press “▲” or “▼” key to adjust the third digit value for remote control coding, the numerical range is 1-5, corresponding five remote controls.
- 2) Choose the Code of Remote Controller, arbitrarily press a key of the remote control. Machine Coding Successfully and Exit Coding State.
- 3) Short press “*” key to exit remote control code.

*Remote Control Requirements: 433mhz, 24-bit code, remote control function is optional function, please specify if you need to place an order.

7. fault alarm

Show the following figure, corresponding to the failure symbol flicker, and corresponding to the failure device icon flicker, display data as fault code, its meaning please refer to the fault table.

*Spark plug, oil pump, fan, sensor, power supply and other symbols flicker indicates that the corresponding device failure.

fault table

Fault code	Cause of failure	solutions
F-2	Power supply voltage range	Normal range: 24V (18-32V), 12V (9-16V). Check whether the battery or generator is normal and whether the fuse is aging

II. Product information

Complete sets of equipment and installation components of heater

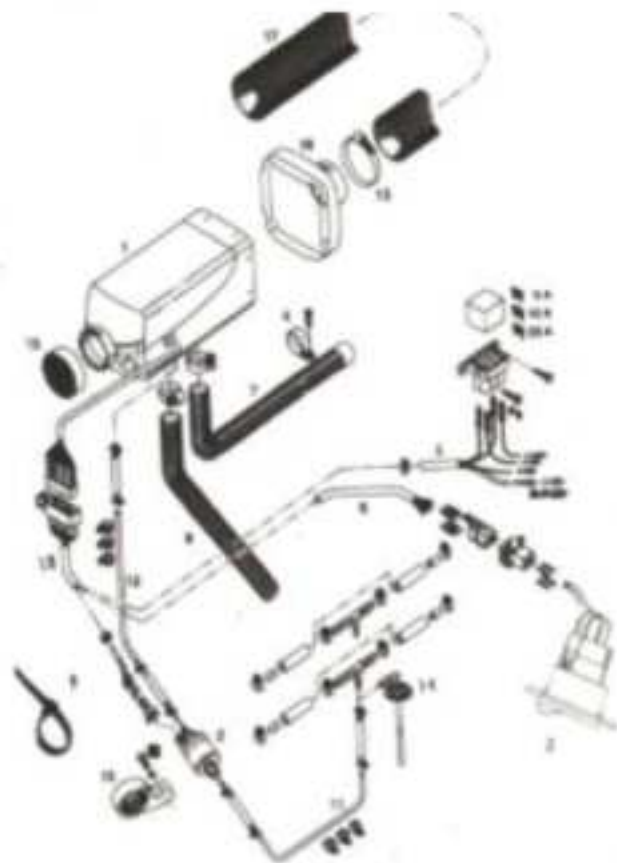

- 1. Heater; 2. Metering oil pump; 3. Control switch; 4. Fixed clamp of exhaust pipe; 5. Output line, positive/negative; 6. Control element transmission line; 7. Exhaust pipe; 8. Combustion air duct; 9. Belting; 10. Dose pump bracket; 11-12 Deoiling pipe; 13. Air outlet hose clamp; 14. Deoiler; 15. Air intake grille; 16. Outlet housing; 17. Air duct; 18. Heater harness

III. Product information

Technical parameters

Element Model	XL-AIRD5					XL-AIRD3				
Heating media	Air					Air				
Heat rating	Level					Rating				
	Super	High-level	Middle-level	Low-level	Close	Super	High-level	Middle-level	Low-level	Close
Calorific value (w)	5000	2500	2000	900	-	3000	2200	1400	900	-
Dielectric flux (kg/h)	185	50	110	60	24	50	120	80	80	24
Fuel consumption (l/h)	0.64	0.40	0.28	0.11	-	0.35	0.25	0.18	0.10	-
Electric power consumption (W)	40	24	13	7	-	24	10	10	7	-
When starting										
Rated voltage	12V or 24V					12V or 24V				
Lower limit under-voltage protection	10.5V or 21V					10.5V or 21V				
Lower limit overvoltage protection	16V or 32V					16V or 32V				
Environmental temperature, heater	When operating		Non operating			When operating		Non operating		
damage oil pump	-40°C to +40°C		-40°C to +85°C			-40°C to +40°C		-40°C to +85°C		
fluid temperature of hot air	-40°C to +50°C		-40°C to +125°C			-40°C to +50°C		-40°C to +125°C		
Weight	About 4.5kg					About 3kg				

Product dimension

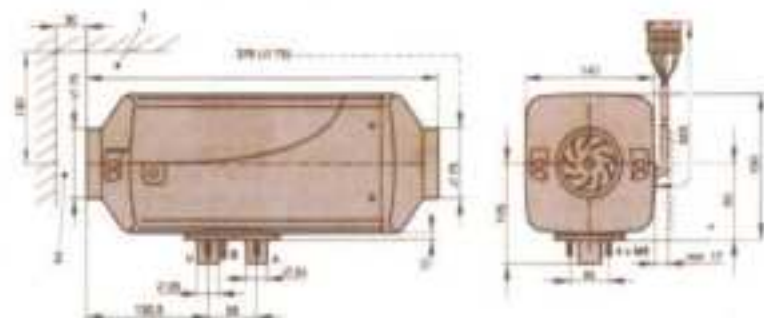

1. It is used in minimum installation space to open cover, dismantle ignition plug and controller.

A=Waste gas

2. It is used in the minimum installation distance to draw the heating air. B=Fuel

* The above figure shows the product dimensions of XL-AIRD5. The V-Combustion air overall length of XL-AIRD3 is 326mm. Other dimensions are the same with the overall dimensions of XL-AIRD5.

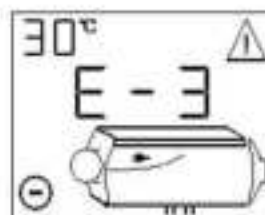

Manual mode has six gears (H1-H6) H6 represents maximum power, as shown above, boot status, add or subtract gears by "▲" or "▼", main engine schematic diagram and bar chart to show the current gear.

automatic mode, the figure above shows the setting of 20 degrees Celsius, add or subtract temperature values by "▲" or "▼", setting range 5-30 degrees Celsius, switching manual/automatic mode by long pressing "☛" keyboard.

2. manual oiling operation

In shutdown state, two seconds after pressing the "▲" and "▼" at the same time, manual control of pumping, stop oiling after releasing the key. please use cautiously!

3. plateau model operation

At the same time, press the button for 2 seconds to enter the plateau mode.

"▲" display start plateau mode, press the "☛" and "ok" key for two seconds to exit the plateau mode at the same time. please use cautiously!

4. setting timing switch time operation

Two seconds after pressing the "ok" and "▼" key at the same time, enter the timing setup time interface, the following figure is shown. tab "🕒" flicker, display shows 10.1 hours on time. if it display OFF, it means setting a timed shutdown time.



- 1) Press "▲" or "▼" key to adjust time value, time range: 1-24 hours.
- 2) Short press "☛" key, switch to adjust digital bits.
- 3) Short press "☛" key, switching the Timed Start-up and Timed Shut-down Time value.
- 4) Short press "ok" key, save the settings and exit the interface.
- 5) Press "☛" key for 2 seconds, do not save the settings, exit this interface.

Operation instructions for parking heater

一. the control panel is shown below

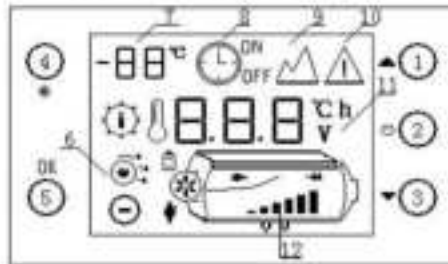

1. overshift key 2. on/off key 3. downshift key 4. setting key 5. deterministic key 6. work status symbol 7. display ambient temperature 8. timing symbol 9. plateau symbol 10. fault symbol 11. display data parameters 12. host schematic

二. use operation

1. switching operation

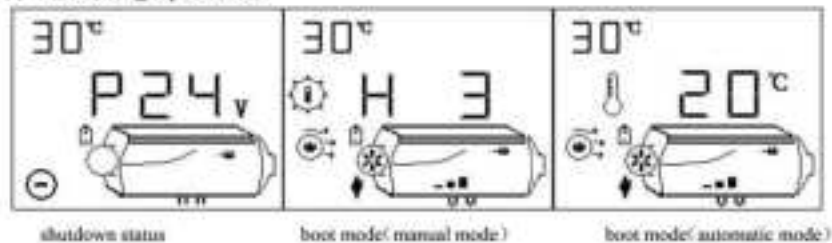

1) boot-up operation

In shutdown state, long press "⊕" key for 2 seconds, equipment start-up, display boot status as shown above.

2) shutdown operation

On-state, long press "⊕" key for 2 seconds, equipment entering blow-off cooling process, display . turn off the equipment after cooling.

At this time, do not force the power off for the cooling block. Direct power failure can damage parts because the body temperature is too high to dissipate heat, only when the machine is turned off can the power be cut off.

3) manual mode operation

III. Installation

Installation position

Fasten the heater on the bottom of vehicle or the vehicle wall with four screws on the stand bar of heater. When installing the heater, enough operation space should be reserved in the air inlet and the place to domestic ignition plug and controller. (The suggested installation position and methods are shown as follows).

Installation position within truck

Within the truck, the heater will be installed in the driving cab.

If it is impossible to install in the driving cab, the heater may be installed in the toolbox or container.

1. The heater is located in the front of co-pilot.
2. The heater is located between driver's seat and co-pilot seat.
3. The heater is located under the underfloor.
4. The heater is located under the back seat.
5. The heater is located in the luggage.

Installation position within RV

Within the RV, the heater is mainly installed in the room or luggage. The heater may also be fastened on the vehicle bottom, but it should prevent the water spraying.



1. The heater is located at the front of co-pilot.
2. The heater is located at the back wall of driving cab.
3. The heater is located at the back of driver's seat.
4. The heater is located in the toolbox.

Installation position in car/large car

In car/large car, the heater mainly is installed in the vehicle's passenger room or luggage.

If unable, the heater may be fastened under the vehicle, but we should note the water spraying.



1. The heater is located in the front of co-pilot.
2. The heater is located between driver's seat and co-pilot seat.
3. The heater is located in the bottom.
4. The heater is located under the counter.
5. The heater is located in the luggage.

Installation position in the driving cab of excavator

1. The heater is located in the box at the driver's seat.
2. The heater is located at the back wall of driving cab.
3. The heater is located in the protection case.



III. Installation

Installation angle and fastening

Allowable installation angle

As shown in the figure, the normal angle should be used to install the heater. According to different installation conditions, the heater may incline 30° (the flowing direction is downward) at most or rotate 90 around the long axis. (Exhaust pipe position, the ignition plug is upward).

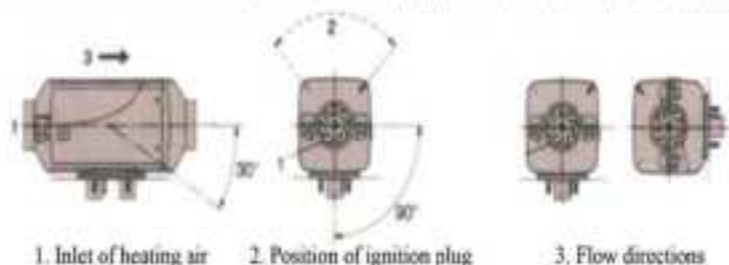

1. Inlet of heating air 2. Position of ignition plug 3. Flow directions

Assembly and fastening

The holes used to process waste gas, combustion air and fuel pipe.
The mounting face of heater legs should be flat.

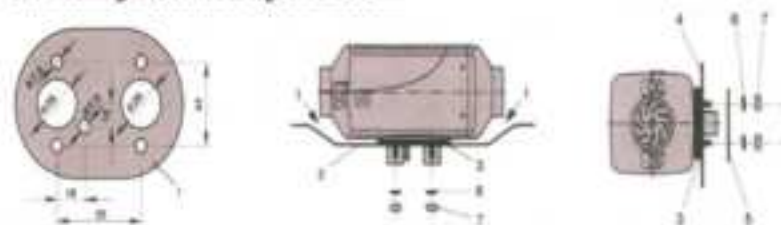

Fasten the heater on the vehicle bottom. Horizontally fasten the heater on vehicle wall.

Be sure to reserve a space between heater and vehicle bottom. In addition, check whether the ventilation wheels operate freely; 2. The assembly surface should be flat; 3. The sealing gasket should be assembled; 4. The vehicle wall should be flat; 5. Reinforcement plate (used when necessary); 6. Spring sheet 7. M6 hexagon nut

Instructions for use of bi-directional remote control receiving



Introduction of buttons

On/Off=long press On/Off

Lighting instructions

There is the light under the switch button, long lighting indicates the start-up and flashing indicates that there is a fault.

Introduction of button functions

Start-up -> When the operating voltage meets the conditions, press On/Off for a long time.

Fuel filling in manual mode

In shutdown state, start the manual oil pumping by pressing On/Off button 3 times continuously and quickly. Please press the On/Off button gently to stop the oil pumping when the air has been removed from the oil circuit. This process requires observation of specially assigned person to avoid excessive fuel entering the machine and black smoke at start-up.

Remote control pairing

In the start-up state, press On/Off button 1 times continuously and quickly, the indicator light flashing means it has entered the remote control pairing waiting state. At the same time, press the power button + setting button on the remote control for a long time to start the remote control pairing. Wait for auto completion of pairing to exit.

Fault state description

Machine fault	State display	Handling method
Power supply under voltage	The indicator light flashes 1 time.	Boost supply voltage
Power supply with over pressure	The indicator light flashes 2 times.	Reduce supply voltage
Ignition plug fault	The indicator light flashes 3 times.	Check whether the ignition plug is in open circuit or short circuit.
Oil pump fault	The indicator light flashes 4 times.	Check whether the oil pump has suffered from broken line or short circuit.
The machine is overheating.	The indicator light flashes 5 times.	Check the temperature sensor on the shell or whether the fan has the abnormal rotation speed.
Magnet fault	The indicator light flashes 6 times.	Check the magnet polarity, the Hall sensor location or the looseness condition of wiring terminal.
Breaker connection fault	The indicator light flashes 7 times.	Check the connecting plug of the power, and whether the blue harness connection has become loose or disconnected.
The flame is extinguished.	The indicator light flashes 8 times.	Check whether the oil circuit has air or blockage, check whether there is fault or temperature sensor on the shell or whether the connection terminal has become loose.
Sensor fault	The indicator light flashes 9 times.	Check whether the sensor plug is loose, broken, or in short circuit.
Failure in ignition	The indicator light flashes 10 times.	Check whether the oil circuit is blocked, or the oil temperature is not smooth, the oil pump is stuck, the revalidation nut is blocked due to the oil product problem, and other reasons that cause that 2 ignition fails to burn normally.

208 Main Board Fault Code Description

Machine fault	LCD panel display	Digital panel display	Each panel display	Handling method
Power supply under voltage		E-01	1 indicator light flash	Check power supply voltage
Power supply with over pressure		E-02	2 indicator light flash	Reduce supply voltage
Ignition plug fault		E-03	1 indicator light flash	Check whether the ignition plug is in good condition or short circuit
Oil pump fault		E-04	4 indicator light flash	Check whether the oil pump is disconnected
The machine is overheating		E-05	3 indicator light flash	Check the temperature sensor on the shell or whether the fan has the abnormal rotation speed
Water fault		E-06	4 indicator light flash	Check the water priority, the full water level and the basic condition of water control
Broken connection fault		E-07	7 indicator light flash	Check the connecting plug of the part, and whether the wire harness connection has become loose or disconnected
The flame is extinguished		E-08	2 indicator light flash	Check whether the oil circuit has air or was blocked, resulting in poor oil supply
Sensor fault		E-09	4 indicator light flash	Check whether the sensor plug is loose, broken, or is disconnected
Failure to ignite		E-10	10 indicator light flash	Check whether the oil circuit is blocked, or the oil temperature is too low, the oil pump is stuck, the combustion air is blocked due to the oil pressure problem, and other reasons that cause that 2 ignition fails to heat normally

The LCD panel fault display is by graphics and numbers and displays in the same row. No numeral number is same as the digital panel fault code.

Bi-directional Remote Control Operation Instructions



1. Operation instruction of buttons

- Start-up/shutdown: Press and hold for 2 seconds to turn on, or turn off
- Confirm button: View best working status
- Up-regulation button: Increase the oil mass or temperature according to the temperature control method.
- Down-regulation button: Increase the oil mass or temperature according to the temperature control method.

2. Remote control pairing operation

In the shutdown state, first long press **down-regulation button** on the LCD panel that needs to be paired first. Showing means it enters the remote control code matching interface.

Then press the **power button** and **confirm button** on the remote control at the same time, the state of **waiting matching** remote control appears on the remote control, the remote control and switch enter the automatic matching process, and after successful code matching, it will automatically exit the code interface and display the normal working parameters. If the code matching failed, it would not enter the normal state of displaying working parameters. The code matching state will be automatically exited when it does not receive remote control code over time.

3. Temperature control mode switching

When the temperature control mode is selected by remote control, only press the **up-regulation button** and **down-regulation button** at the same time to display the temperature when switching to automatic temperature control, and it will display the oil mass if the temperature is controlled manually.

4. Working status adjustment

The working status of the heater can be adjusted at any time by remote control. The methods are as follows:

Up-regulation button: Increase the pump oil amount (manual temperature control mode) or raise the setting temperature to increase the output temperature of the heater.

Down-regulation button: Decrease the pump oil amount (manual temperature control mode) or reduce the setting temperature to decrease the output temperature of the heater.

1. III. Installation

Installation of combustion air duct and exhausting device

Guiding device of combustion air
The installation components contain a Flexible combustion air hose and the inner diameter is 25mm. According to the installation conditions, the length of combustion air duct may be shortened to 30cm or prolonged to 1m at most.
Fasten the combustion air duct on heater with hose clamp. Another end is fastened with ribbon to prevent shaking and falling.



Exhausting device

The installation components should contain one exhaust pipe that the inner diameter is 24mm. According to the installation conditions, the length of exhaust pipe may be shortened to 30cm or prolonged to 1m at most.
Fasten one end of exhaust pipe to heater with hose clamp and fasten another end on the vehicle with support.

Safety instructions for exhausting device

- In the whole operation process from the heating operation, all parts of waste gas exhaust device will be burnt.
- Therefore, be sure to install the exhausting device according to the installation instructions.
- The outlet of exhaust air should be placed outside the vehicle.
- The waste pipe should not go beyond the boundary on the vehicle side.
- The exhaust pipe should be placed downward to facilitate the discharge of condensate water.
- It should not affect the functions of parts which are important for the vehicle operation (note to keep enough spacing).
- When installing, note to keep enough spacing between the exhaust pipe and heat sensitive components. We should pay particular attention to the fuel pipe, wire and brake line.
- To prevent the exhaust pipe from vibration and damages, it should be fastened stably (the recommended reference spacing is 50cm).
- When paving exhaust pipe, note that the waste gas which is discharged should not be used as the

Safety instructions for guiding device of combustion air

- The orifice of combustion air duct should keep unblocked.
- When installing the suction inlet of combustion air, note that the waste gas should not be taken as the combustion air.
- The suction inlet of combustion air should not align at the driving direction.

- 1 and 2. Hose clamp; 3.Exhaust pipe;
- 4. Combustion air pipe; 5. Inlet and outlet; 6. Sleeve of waste gas pipe; 7. Clip of inlet pipe

- The opening of exhaust pipe should not be blocked by the dirt and snow.
- The opening of exhaust pipe should not direct to the driving direction.

Protection instructions

- It will produce heat and toxic gas in burning time. Please install the exhausting device according to the installation instructions.
- In the heating period, it should not operate in the area where the exhaust guiding device locates in.
- When operating on the waste gas discharge device, firstly close the heater until all parts are cooled. Wear the protective gloves when necessary.
- Do not take the waste gas.

III. Installation

Installation notes for heating air duct

Heating air duct

The installation components contain one flexible pipe that the diameter is $\phi 75\text{mm}$.

Safety instructions

When paving and fastening the heating air guide tube or hot air outlet, we should not touch it directly due to high thermal radiation or directly blow the humans, animals or thermal sensitive materials with hot air, or it will cause unnecessary damages and injuries.

In the whole operation process starting from heating, the thermal air conduit will be in high temperature. Therefore, the operation in the thermal air conduit should be avoided in the whole heating process. If the operation in the area is required, firstly close the heater. When all parts are completely cooled, wear the protective gloves when necessary.

Notes

When placing the suction inlet of heating air, note that the waste gas from vehicle engine and heater should not be taken and the heating air should not permeate the dust and salt fog under the normal operation conditions.

When heating with circulating air and placing the suction inlet of circulating air, note that the heating air cannot be directly taken in.

In case of fault caused by heating, the local thermal air temperature may reach 15°C and the surface temperature may reach 90°C before shutdowns. Therefore, it is allowed to guide the heat air with the high temperature air hose in the company's installation components.

When checking the functions, after operating about 10 minutes, the average temperature of discharged heat air which is measured at about 30cm from the outlet should not exceed 110°C (the air suction temperature is about 20°C).

The heater and air conduit and other components should not be trampled, covered and pressed. Or it will injure the personnel, burn the inflammables or damage the heater.

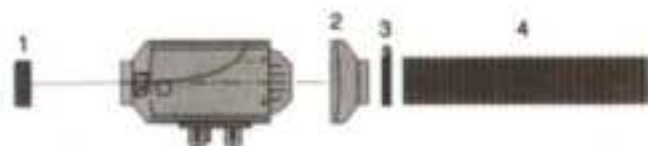

1. Truck grille protection

2. Outlet housing

3. Hose clamp

4. Soft air duct

will automatically exit the interface, then, it shows normal working parameters. If the code matching failed, it would not enter the normal state of displaying working parameters. The code matching state will be automatically exited when it does not receive remote control code over time.

6. Description of parameter setting procedure (press setting button to enter setting state)

- Time setting** → Press the up-regulation button or down-regulation button to adjust parameters → setting parameters of hour (24-hour system) and minute successively, and press confirm button to confirm the parameters to enter the next item.
- 2 Timed start-up setting** → Closed by default, it shows **1#**, press up-regulation button to start up, it shows **1#**, press confirm button to enter → Setting of hours, minutes in turn. Timing is the countdown, maximum is 99 minutes and 59 seconds.
- 3 Timed shutdown setting** → Closed by default, it shows **1#**, press up-regulation button to start up, it shows **1#**, press confirm button to enter → Setting of hours, minutes in turn. Timing is the countdown, maximum is 99 minutes and 59 seconds.
- Inputting of administrative password** → Press up - down button to adjust, when the correct number appears, press confirm button to enter the next digit, after the 4-digit password is entered correctly, press confirm button to enter the next item, input error will lead to returning to the step of waiting the first number to enter. There is no need to modify subsequent data, press setting button until it exits, or wait for 10 seconds, it will exit automatically for overtime.
- 4 Setting of pump oil amount** → Press up-regulation button or down-regulation button to modify minimum pump oil amount, after it reaches the required number, press confirm button to enter minimum oil mass setting. → Press up-regulation button or down-regulation button to modify maximum pump oil amount, after it reaches the required number, press confirm button to enter the next item.
- 5 Fan speed setting** → Press up-regulation button or down-regulation button to modify minimum fan speed, after it reaches the required number, press confirm → Press the up-regulation button or down-regulation button to modify the maximum fan speed to reach the required value, and then press

Instructions for Use of 12V - 24V General LCD Panel



1. Button function

- ◀ → In the setting state, increase the setting parameter, non-setting state, increase the working temperature or oil mass.
- ON/OFF → Short press start-up button, LCD screen displays , and long press shutdown button for 3 seconds, LCD screen displays .
- ▶ → In setting state, decrease the setting parameters, in non-setting state, decrease working temperature or oil mass. The basic operation can be returned to above state, and the following operation descriptions can be used for settings.
- Setting → Enter the setting state, adjust setting parameters, and change the working status of the machine.
- Confirm → Under the setting state, confirm the current setting value and enter the next parameter setting. View the machine state in the non-setting state.

2. Query machine status (keep short press of the confirm button to switch one state at a time to make it display cyclically)

- Time display → Ambient temperature display → Setting temperature display (automatic temperature control)/setting oil mass display (Manual temperature control)
- Press confirm button to view cyclically → History fault code display → Altitude display
- Supply voltage display

3. Description of fuel filling in manual mode

Under the shutdown state, press the down-regulation button and setting button simultaneously to conduct fuel filling manually, which displays , and after releasing, press up-regulation button and it displays , the oil pump starts to work. You can hear the sound of the oil pump working and the oil pump icon lights up. Press down-regulation button to display , exit fuel filling, the oil pump icon disappears. The process of live air evacuation shall be done under watch, when the oil reaches the position of the oil inlet of the machine, it can be stopped. If there is too much oil enters the machine, there will be black smoke when lighting.

4. Description of temperature control mode switching

Press the up-regulation button and confirm button simultaneously to conduct temperature control mode switch. There are manual temperature control mode (oil mass adjustment shows , number represents the oil mass) and automatic temperature control mode (temperature adjustment shows , number represents the temperature). The difference between two modes is that: in automatic mode, pump oil amount can reach the maximum upon parameter setting and the machine heat is higher, the manual pump oil amount is limited to the current setting value and will not reach the maximum oil value set by the parameter, which makes gears clearly slower and is very convenient for the part old hands.

5. Description of remote control code matching

In the shutdown state, press power button and confirm button simultaneously in the remote control first, then text of waiting for matching appears on the remote control, then keep long press up-regulation and down-regulation buttons of LCD panel. When showing it enters the remote control code matching interface, upon success, it

III. Installation

Fuel supply

Installation angle of dose oil
When installing dose oil, note that the nozzle should be upward. The installation angle should be larger than -15° . The installation angle between 15° and 35° should be given priority. As shown in the figure below:

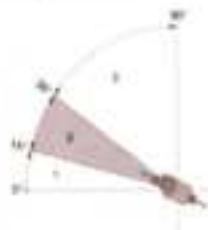

1. It is not allowed to select the installation angle between 0° - 15° .
2. Give priority to the installation angle between 15° - 35° .
3. It is allowed to select the installation angle between 35° - 90° .

Connection of oil pipe

When connecting the oil pipe, after inserting heater oil nozzle, pump oil nozzle, oil taker and T-shaped TEE oil nozzle into the rubber hose, it should be connected to the oil pipe in next end to prevent bubbles in the oil channel, or it will produce noise and influence the combustion effect.



1. Correct connection; 2. Wrong connection - forming bubbles

Installation angle of T-shaped TEE parts

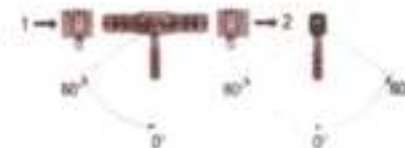

1. From oil tank 2. Lead to auto engine

Take oil from oil tank near to the oil channel of auto engine with T-shaped TEE parts



1. Deoiling pipe 2. Lead to auto engine oil pump 3. T-shaped TEE parts 4. Deoic oil pump
5. Connecting hose 6. Oil pipe

III. Product information

Deoiling Installation Diagram of Deoiler

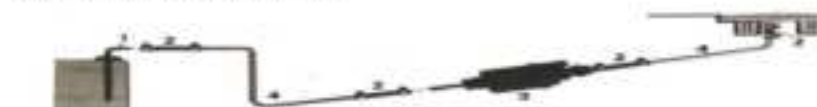

1. Deoiler
3. Deoiling oil pump

2. Connecting hoses
4. Deoiling pipe

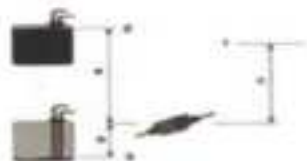

1. Joint on the heater
2. Maximum oil pressure height
3. Minimum fuel contents

Notes

- a. The vertical height a when the oil pump is installed below the oil tank shall be 3m maximally.
b. The vertical height b when the oil pump is installed above the oil tank shall be 1m or 0.5m at the most in case of diesel oil or gasoline.
c. The vertical height c from the oil pump to the heater (the oil pump shall be installed below the heater) shall be 2m maximally.

Safety Instructions of Deoiling Pipe Laying

- In order to avoid the oil pipe damage or give rise to noise due to the vibration, the oil pipe shall be fixed firmly.
- During the laying, please avoid the oil pipe twisting, friction or vibration caused by the vehicle reversing or engine movement.
- The oil circuit shall keep away from the heat source, instead of being laid under the high-temperature environment. Please don't lay the exhaust pipe or fix the oil pipe along with the heater or vehicle engine at close range. When it is necessary to cross over these pipelines, please keep the enough heat insulation distance and put the protective hose when necessary.
- Please install all oil supply equipment, then, check the adapting pieces and the oil leakage phenomenon after heater has been started and operated for a certain period of time.
- The oil pump which is installed on the vehicle will be prohibited to provide oil for the heater.

Operating Requirements of T-shaped Triple Valve Body

In order to avoid the fuel oil injection in the heater and the huge risks under the high pressure of vehicle oil pump, the triple valve body shall be installed between the vehicle oil pump and engine. The vehicles of which the vehicle oil pump is installed in the oil tank shall apply the deoiler, instead of T-shaped triple valve body, to extract the oil.

Oil Circuit Maintenance and Overhaul Precautions

- Please check whether the adapting pieces of oil circuits have become flexible before using the heater in winter. Check whether the connecting hose and oil pipe have become aging. Check whether the connection between the oil circuits have suffered from electric leakage when the heater has been operated for a certain period of time. Any problems found should be solved promptly.
- When the heater is used for the first time, the heater is likely to be unable to be started during the early several launching due to the long-term unused behaviors. This is the normal phenomenon, at this moment, please start it for several times until the oil pump can suck up the fuel oil.

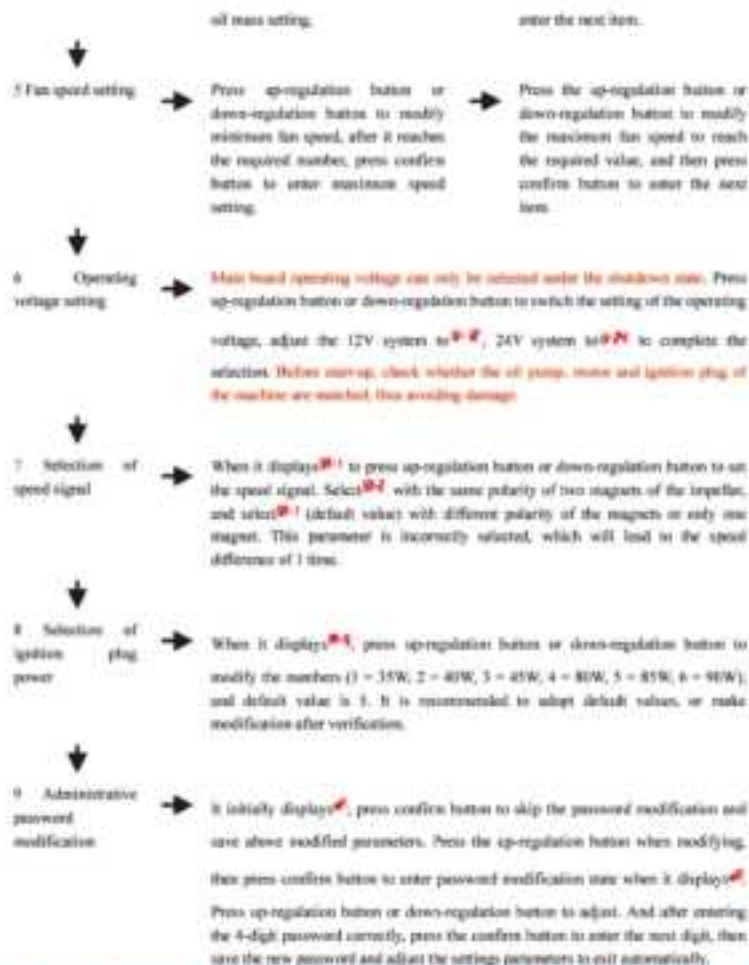

Precautions: For check time, set the timing of start-up and shutdown, and it will take effect immediately after setting. After setting all parameters after the administrator's password, you must press confirm button until to the last 9 to exit, through which we could save the set parameters. If getting in the machine, previous adjustment data will be lost and invalid. Please check each new digit of password carefully and save it, through which you can come to the parameter modification next time.

difference between two modes is that: in automatic mode, pump oil amount can reach the maximum open parameter setting and the machine heat is higher, the manual pump oil amount is limited to the current setting value and will not reach the maximum oil value set by the parameter, which makes gears clearly shown and is very convenient for the part old hands.

5. Description of remote control code matching

In the shutdown state, long press the LCD panel **down-regulation button**, enter the remote control code matching interface to make it display **000**, then press the **the button** of remote control to transmit the remote control code, and successful code matching will make it automatically exit the code interface, if the code matching fails, it will not enter the start-up state. The code matching state will be automatically exited when it does not receive remote control code over time.

6. Description of parameter setting procedure (press **up-regulation button** to enter setting state)

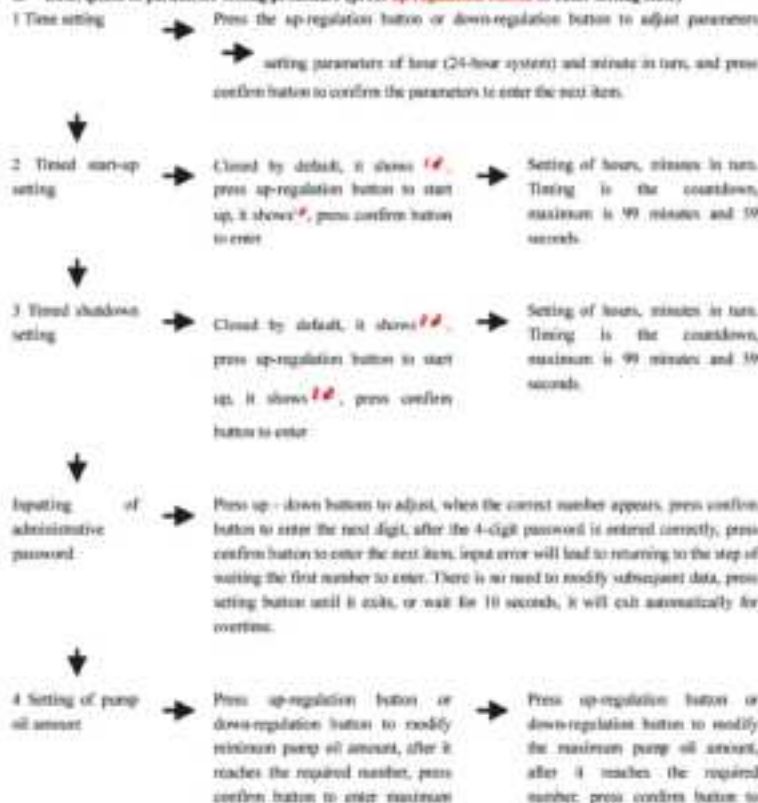

IV. Operation and Control Mode

Fuel filling

- You shall infill the oil circuit via the fuel oil infilling function when you have installed heater host, oil circuit and electric circuit, otherwise, the heater is likely to fail to be started due to the fuel oil absence in the oil circuit.

The fuel oil shall be refueled in the following way: Press the rocker switch for 8 times continuously at the following frequency after connecting the power line correctly, namely, open it for 1 second and close it for 1 second. At this moment, the heater will start the fuel oil heating procedures to continuously send out the drive pulse of fuel metering pump and keep it for 5 minutes. During that period, the indicator on the rocker switch will flicker at the one-second on and one-second out frequency, moreover, the buzzer will make beep. You shall pay continuous attention to the fuel oil's position in the oil circuit during the refueling period of fuel oil. When the fuel oil has approached the heater oil inlet for 10cm, please turn off the rocker switch to stop the refueling process.

V. Circuit

Wiring of heater

Safety instructions

It is requested to realize the electrical connection of heater according to the electromagnetic compatibility principle

- Considering that the electromagnetic compatibility will be affected by the misoperation, please abide by the following requirements:
 - Please make efforts to avoid destroying the insulation of power line and prevent abrasion, breakage, clamping or thermal influence.
 - As for the waterproof plug, please make use of blind plug to block the unoccupied plug cavity and prevent the dirt and water.
 - Please realize the electric connection and grounding firmly without corrosion.

Notes

Please pay attention to the following affairs when the electric wiring and element operation are conducted for the heater:

- Please keep away from the overheating parts to avoid the heating & humidity and affected function when the electric line, switch and controller are installed in the automobile.
- Please don't fix the hardness on the moving or vibrating components to avoid the tensile failure or joint falling when the hardness is fixed.
- The positive and negative electrode of the hardness shall not be lengthened without permission.



- Red (1.5mm) - positive electrode of storage battery (main control board)
- Black (1.5mm) - negative electrode of storage battery (main control board)
- Black (0.5mm) - negative electrode of oil pump (main control board)
- Orange (0.5mm) - positive electrode of oil pump (main control board)
- purple (0.5mm) - communication (main control board)
- Red (1.5mm) - positive electrode of storage battery
- Black (1.5mm) - negative electrode of storage battery
- Orange (0.5mm) - negative electrode of oil pump
- Orange (0.5mm) - positive electrode of oil pump
- White (0.5mm) - rocker switch No
- Blue (1.5mm) - rocker switch OFF
- Red (1.5mm) - negative electrode of indicator
- Green (1.5mm) - positive electrode of indicator

	Temperature sensor
	Main control board
	Positive electrode of draught fan
	Negative electrode of draught fan
	Indicator
	Rocker switch B
	Rocker switch B
	Positive electrode of oil pump
	Negative electrode of oil pump
	negative electrode
	Positive electrode
	Communication
	Positive electrode of ignition plug
	Negative electrode of ignition plug
	Wind turbine
	Ignition plug
	Plug B
	Plug A
	Safe electric current: 10A
	Safe electric current: 3A
	Storage battery
	Rocker switch
	Oil pump

VI. Fault, maintenance and service

Fault and handling

- The heater cannot start upon startup.
- Shutdowns, Restart after shutdowns.
- The heater still does not start, the following should be checked:
- Whether there is fuel in the

- The heater is likely to be out of order when the heater is used abnormally. The general using conditions, faults and disposing methods will be listed below.

Item	Unit	Minimum value	Normal value	Maximum value
Rated voltage	V	21	27	32
Rated voltage current	A	0.06	2	10

Instructions for Use of 12V - 24V General LCD Panel

1. Button function

• → In non-setting state, increase the working temperature or oil mass. In the setting state, increase the setting parameter.

On/OFF → Long press for 3 seconds to start-up, the screen displays and long press 3 seconds to shutdown, the screen displays .

▶ → In non-setting state, decrease the working temperature or oil mass. In the setting state, the above state is sufficient for the basic operation of decrease the setting parameters. Other operations are described as follows.

Parameter settings → Press the **up-regulation button** for a long time to enter the setting state. Setting parameters can be adjusted to change the working status of the machine.

In the parameter confirmation → setting state, confirm the current setting value by pressing **On/OFF button** to enter the next parameter setting. In the non-setting state, press **On/OFF button** to view the running state of the machine.

Remote control code matching → Press **down-regulation button** for a long time to enter the remote control pairing state, and press remote control power button for pairing. Please refer to the description later for detailed operation.

Temperature control conversion → Switch the temperature control mode by pressing and holding the **up-regulation and On/OFF button** at the same time. Please refer to the following description for details.

Fuel filling → Press and hold **down-regulation button and On/OFF button** at the same time to start the fuel filling function, as described later.



2. Query machine status (keep short press of the **On/OFF button** to switch one state at a time to make it display cyclically)

New display → Ambient temperature display → Setting temperature display (automatic temperature control/setting oil mass display (Manual temperature control))

↑ Press confirm button to view cyclically → History fault code display → Altitude display → Supply voltage display

3. Description of fuel filling in manual mode

Under the shutdown state, press the **down-regulation button and On/OFF button** simultaneously to conduct fuel filling manually, which displays , and after releasing, press up-regulation button and it displays , the oil pump starts to work. You can hear the sound of the oil pump working and the oil pump icon lights up. Press down-regulation button to display , exit fuel filling, the oil pump icon disappears. The process of live air evacuation shall be done under watch, when the oil reaches the position of the oil inlet of the machine, it can be stopped. If there is too much oil enters the machine, there will be black smoke when igniting.

4. Description of temperature control mode switching

Press the **up-regulation button and On/OFF button** simultaneously to conduct temperature control mode switch. There are manual temperature control mode (oil mass adjustment shows , number represents the oil mass) and automatic temperature control mode (temperature adjustment shows , number represents the temperature). The

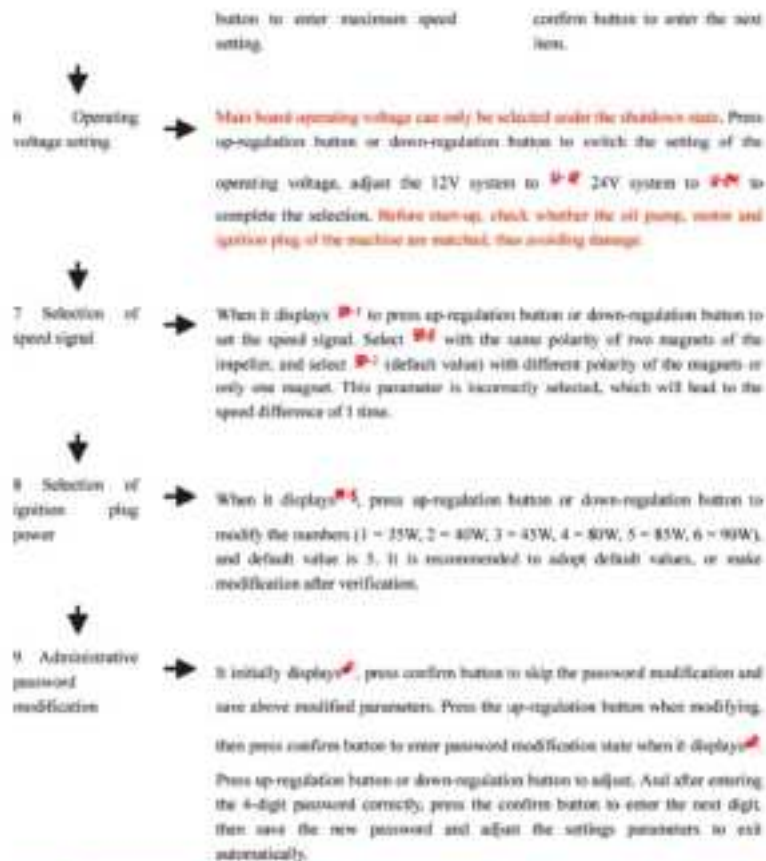

Precautions: The check time, set the timing of start-up and shutdown, and it will take effect immediately after setting. After setting all parameters after the administrator's password, you must press confirm button until to the item it to exit, through which we could save the set parameters. If quitting in the midway, previous adjustment data will be lost and invalid. Please check each new digit of password carefully and save it, through which you can enter to the parameter modification next time.

oil tank and oil pipe?
 - Whether the fuse is normal?
 - Whether the circuits, the connection and the connectors are in good condition?

Movement Noise	dB	35	55	65
Fuel oil consumption	Li m³/hr	0.138	-	0.472
Recirculating wind flow	cfm	30	-	85

Please contact with the sales persons or manufacturers when the heater still fails to be normally started or steadily operated on the premise that the foregoing contents are normal.

Please pay attention to the followings:

Supposing that the heater is changed by others or due to the unknown installed components, or the heater is destroyed without normal operation due to the artificial factors, the customers will lose the power to ask the manufacturers to make repairing.

VI. Fault, maintenance and service

Maintenance instructions

- The heater shall be started for 10 minutes in summer and other months when the heater is not used.
- Please make the pilot run for the heater before the using period.
- Please close the heater as long as there is dense smoke for long term, or abnormal combustion noise or fuel smell or overheating electrical/electronic component.
- Take out fuse. Seek an advice from the installation company for inspection.
- Please check the oil circuit carefully before the using period of the heater, and check whether the connection has become flexible and whether the oil pipe has become aging. Please check whether there is oil leakage on the connection when the heater has made pilot run for a certain period of time.
- Please check the opening of heating air duct, combustion air duct and exhaust pipe after long-term unused behaviors. When necessary, please wash them.

Service

When you have any technical problem or your heating equipment is out of order, please contact with the sales installers in time.

After-sales Warranty

Dealer: _____ MM/DD/YY

User's name: _____ Contact No.: _____

Heater Model:		Installation position:	
Type of license plate:		Installation time:	
Vehicle type:		Installer:	
Maintenance time:		Maintenance items:	

Rotary Knob Panel Instructions



Introduction of keys:
ON→startup
OFF→ shutdown
Rotary knob→temperature adjustment and wind speed control
Lighting instructions:
 Considering that there is lighting below the ON/OFF key, the operators will find out the rotary knob easily under the dark environment. The lighting on the outside of rotary knob will show the temperature value and failure state.

Key function introduction

ON→Please press the ON key gently when the working voltage has satisfied the related conditions.
OFF→ Please press the OFF key gently when the machine is under the working state.
Rotary knob→the temperature will rise when the rotary knob is rotated clockwise, at this moment, the red indicators will be increased on the outside of the rotary knob.
 The temperature will down when the rotary knob is rotated anti-clockwise, at this moment, the red indicators will be reduced on the outside of the rotary knob.

Fuel filling by hands

Please rotate the rotary knob clockwise under the OFF state until the red indicators are on, then, please press the OFF button for more than 3 seconds, at this moment, the manual oil pumping will be started. Please press the OFF key gently to stop the oil pumping when the air has been removed from the oil circuit.

Fault state description

Machine fault	State display	Treatment method
Under-voltage of power supply	1 indicator flickers	Increase the voltage of power supply
Overvoltage of power supply	2 indicators flicker	Reduce the voltage of power supply
The ignition plug is out of order	3 indicators flicker	Check whether the ignition plug has suffered from open circuit or short circuit.
Oil pump fault	4 indicators flicker	Check whether the oil pump has suffered from broken line or short circuit.
The machine is overheating	5 indicators flicker	Check the temperature sensor on the shell or whether the fan has the abnormal rotation speed.
Motor fault	6 indicators flicker	Check the magnet polarity, the Hall sensor location or the

In the condition of not setting, press raised first, press the confirmation key at the same time, to keep more than 3 seconds. Remote control to the code into the interface, display HFA -, press on the remote control to open fire away.
 Control code, the code after the exit of code interface, the machine into the boot state, if the code does not enter the boot failure state. Timeout is wrong code automatically withdraw from code.



LCD panel using the above method



Warnings

1. The fixed backboard shall be sealed and separated from the vehicle sheet metal during installation to avoid the physical injury to the driver when the combustion gas flows in the driving cab from the gap.
2. The exhaust pipe length shall be 30cm at least.
3. The exhaust gas outlet shall be firmly placed in the empty space.
4. The exhaust pipe outlet shall not look at the driving direction.

Recommendations: It is suggested to apply the sealant to block off the installation gap when the heater has been fixed.

Note: after all parameters are set, you must press the OK key to quit and save the set parameters. If you quit by pressing the Set key, the parameters will not be saved. Please carefully check each digit of the new password, and keep it in mind so that you can use it to change parameters next time.

4. Description of Machine Status Query

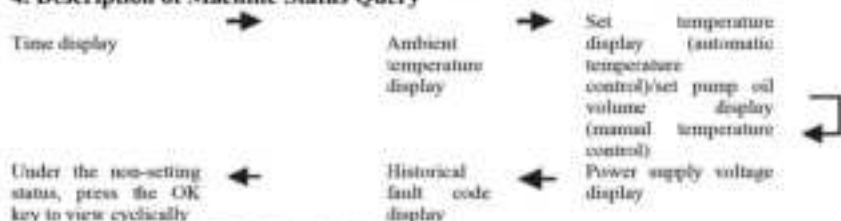

5. Manual Fuel Filling Description

Under the non-setting status, first press and hold the down arrow key, and then press the OK key simultaneously to enter the manual oil pumping interface. When H-OFF is displayed, first release the OK key, and then release the down arrow key. Press the up arrow key to activate manual oil pumping, H-ON will be displayed and you will hear the oil pumping noise. Simply press the down arrow key or the Set key to deactivate it and quit the manual oil pumping.

6. Timed Startup/Shutdown Description

After setting the run time, press the OK key to enter the timed startup/shutdown setting function. By default, OF indicates the off status, and please press the up arrow key to activate the ON status, then you can press the OK key to set the first group of values, with the hour and minute values for the startup to be set first, and secondly enter and set the hour and minute values for the shutdown if the values for the startup are set. Then, press the OK key to enter the second group of values, with similar setting measures as those of the first group. You may specify an interval between the two groups of values. The timing function can only be performed once upon each setting, i.e. if the set timing values are performed, they will be invalid, and you need to reactivate the timing function and set new values for the timing.

7. Temperature Control Mode Switchover Description

Under the non-setting status, first press and hold the up arrow key, and then press the Set key simultaneously, if the panel displays P-tx (xx indicates pump oil volume), it indicates that you have entered the manual temperature control mode and the pump oil volume for operation is restrained within a range between the current pump oil volume and the initial pump oil volume. When you press the above mentioned keys simultaneously and the panel displays xx °C (xx indicates temperature value), it indicates that you have entered the automatic temperature control mode and the pump oil volume for operation is restrained within a range between the maximum pump oil volume and the initial pump oil volume. Under the two modes, the automatic changes of pump oil volume both depend on the variation of the temperature, but the difference between the two modes is that, under the automatic mode, the pump oil volume can reach the maximum value set for the parameter, which leads to higher temperature of the machine; under the manual mode, the pump oil volume is limited to the current setting value and can not reach the maximum value set for the parameter, thus the equipment's temperature is limited to the selected range, which is more adaptable to certain old-fashioned drivers.

8. The instructions on the LCD panel

		looseness conditions of wiring terminal.
Break line fault	7 indicators flicker.	Check the connecting plug of panel, and whether the blue harness connection has become flexible or disconnected.
The flame is extinguished.	8 indicators flicker.	Check whether the oil circuit has air or blockage, check whether the temperature sensor on the shell is out of order or whether the connector terminal has become flexible.

Fault Code Description

Machine fault	Status display	Solution
Undervoltage power source	Panel display E-01	Raise the power supply voltage
Overvoltage power source	Panel display E-02	Reduce the power supply voltage
Ignition plug fault	Panel display E-03	Check whether the ignition plug is open-circuit or short-circuit
Oil pump fault	Panel display E-04	Check whether the oil pump is disconnected or short-circuit
Machine overheat	Panel display E-05	Check the temperature sensor on the shell, or check whether the fan revolution speed is abnormal
Motor fault	Panel display E-06	Check the polarity of the magnet and the position of the Hall sensor
Disconnection fault	Panel display E-07	Check the connecting plug to the panel, and verify whether the connection of the blue communication line is abnormal
Flame extinguishment	Panel display E-08	Check whether the oil line has any air or whether it is obstructed. Check whether the shell temperature sensor is malfunctioning, or whether the contact of the socket terminal is abnormal.

The contents in the table are subject to the digital panel. Faults of the panel with remote control function are identical with the description in the above table. Faults of the panel with knob control are identical with the description in the above table, but the display mode of fault is indicated by the times of blinking of an indicator.

12V-24V Common Digital Panel Operation Instruction

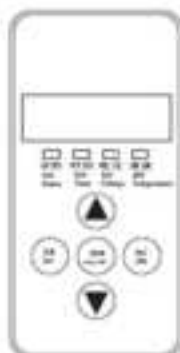

1. Indicators

Status-> Permanently on upon startup, blinking upon the initialization of shutdown, off upon the completion of shutdown

Time-> Permanently on when displaying the time or setting the timed startup or shutdown, and off under other statuses.

Voltage-> Permanently on when displaying voltage or setting the parameters in relation to voltage, and off under other statuses

Temperature-> Permanently on when displaying the ambient temperature or setting the operating temperature, and off under other statuses.

2. Key Function

▲ -> Under the setting status, press it to raise the parameter to be set; under the non-setting status, press it to raise the operating temperature to be set

Set-> Enter the setting status to adjust parameters and change the machine's operating status

On/off -> Promptly press it to start up the machine, and the status indicator becomes permanently on; press and hold the key for 2 sec to shut down the machine, and the status indicator becomes blinking

OK-> Under the setting status, press it to confirm the current setting value and proceed to the next parameter to be set; under the non-setting status, press it to view the machine's status

▼ -> Under the setting status, press it to reduce the parameter to be set; under the non-setting status, press it to reduce the operating temperature to be set

Description of Setting Parameters (Press the Set Key to Enter)

1. Time setting
Use the up/down keys to adjust the parameter → Press the OK key, and consecutively set the Hour (24-hour system) and the Minute, and press the OK key to proceed to the next parameter.
2. Timed startup and shutdown setting
It is off by default, displaying 1-OFF; press the up arrow key to activate it, displaying 1-on → Press the OK key to consecutively set the first group of startup/shutdown time values and the second group of startup/shutdown time values, and then press the OK key again to proceed to the next parameter

- Admin password input → Press the up/down arrow keys, and when the correct value appears, press the OK key to proceed to the next digit. After all four digits are input correctly, press the OK key again to proceed to the next parameter
3. Pump oil volume setting → Press the up/down keys to modify the minimum pump volume, and press the OK key when the required value is set → For the maximum pump oil volume setting, use the up/down arrow keys to modify it as required, and then press the OK key to proceed to the next parameter
4. Fan revolution speed setting → Press the up/down arrow keys to modify the minimum fan revolution speed, and press the OK key when the required value is set → For the maximum fan revolution speed setting, use the up/down arrow keys to modify it as required, and then press the OK key to proceed to the next parameter
5. Operating voltage setting → *The main board's operating voltage can only be adjusted under the shutdown status. Press the up/down arrow keys to switch the operating voltage to the 12V system (displaying U-12) or to the 24V system (displaying U-24). (Before startup, please check whether the oil pump, the motor and the ignition plug are suitable to each other, to avoid damage).*
6. Revolution speed signal selection → Press the up/down arrow keys to set the revolution speed signal. Select 1 if the vane wheel has two magnets with the opposite polarity or has only one magnet. Please select 2 if the vane wheel has two magnets with the same polarity. If the parameter is incorrect, 1-fold speed error will occur.
7. Admin password modification → By default, the OFF status is displayed. Press the OK key if no modification is needed, to skip the password modification and automatically quit after saving the parameters. Press the up arrow key, and when the ON status is displayed, press the OK key to enter the modification status, and input a 4-digit new password, and press the OK key again to save the new password and the adjusted parameters for automatic quit