

INSTALLATION, OPERATION AND MAINTENANCE INSTRUCTIONS

SOLAS – LED Luminaire

ATEX & IECEx

Important: Please read these instructions carefully before installing or maintaining this equipment. Good electrical practices should be followed at all times and this data should be used as a guide only.

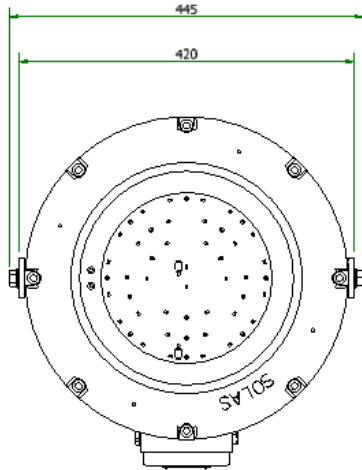

Weight :- Emergency - 29kg
Non Emergency - 24kg

Windage :- 0.13m²

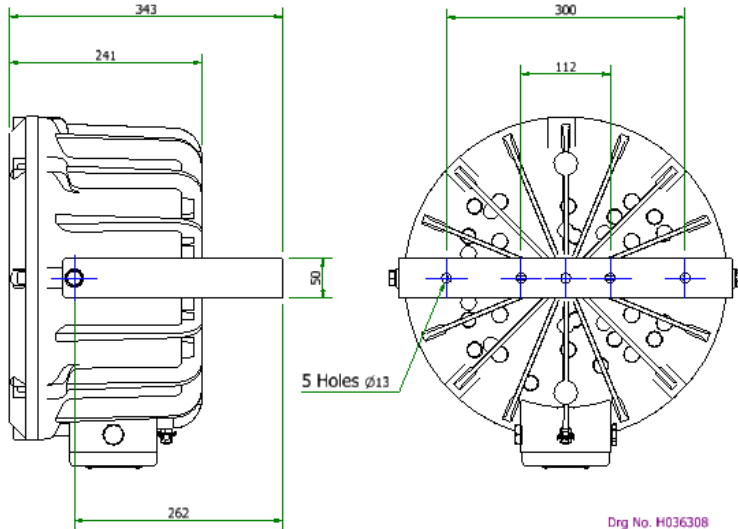

Dwg No. H036308



Type Of Protection	Ex de (flameproof and increased safety), Ex tb (dust)
Protection Standards	(IEC) EN 60079-0, (IEC) EN 60079-1, (IEC) EN 60079-7, (IEC) EN 60079-31.
Area Classification	Zone 1 and Zone 2 areas to (IEC) EN 60079-10-1 Zone 21 and Zone 22 areas to (IEC) EN 60079-10-2
Installation	(IEC) EN 60079-14
Certificate	IECEX Certificate of Conformity IECEX BAS11.0047 EU- Type Examination Certificate Baseefa11ATEX0090
Equipment Coding	Ex db eb IIB T5 Gb Tamb $^{**}C \leq Ta \leq +^{**}C$ (see operating temperature range) Ex tb IIIC T100°C Db IP6X
ATEX Coding	Ⓜ II 2 GD
Ingress Protection	IP66/67 to EN/IEC 60529
Operating Temperature Range	-55°C to +55°C (Non Emergency) -20°C to +55°C (Non Maintained Emergency) -55°C to +55°C /LT (Non Maintained Emergency) or (-50°C to +55°C when fitted with screw connection /SC/ in part coding). -20°C to +45°C (Maintained Emergency) -55°C to +45°C /LT (Maintained Emergency) or (-50°C to +55°C when fitted with screw connection /SC/ in part coding).
CE Mark	 <p>The CE marking of this product applies to "The Electrical Equipment (Safety) Regulations 2006", "The Electromagnetic Compatibility Regulations 2004", the "Waste Electrical and Electronic Equipment Regulations 2006" and the "Equipment and Protective Systems intended for use in Explosive Atmospheres Regulations 1996". [This legislation is the equivalent in UK law of EU directives 2014/35/EU, 2014/30/EU, 2012/19/EU and 2014/34/EU respectively].</p> <p>The Equipment is declared to meet the provisions of the ATEX directive (2014/34/EU) by reason of the EU Type Examination and compliance with the Essential Health and Safety Requirements.</p> <p>M Poutney Technical Manager</p>

SPECIAL CONDITIONS FOR SAFE USE

None

1.0 Introduction – SOLAS Luminaire

The Solas is designed to be used from mains voltage and as a maintained or non-maintained emergency light. The emergency duration is for 90 minutes on full power or 180 minutes on half power. Situations where an area needs to be lit for escape purposes (life boat stations) 90 minute full power would be used. This is a specialised system which the luminaire incorporates 34 x 1w LED's, mains driver, emergency inverter and internal battery pack.

The battery is a 7Ah Ni-Cd with 18 cells. The battery is split into three sections which are individually monitored for voltage, in order to control over voltage and low voltage cut-off in a safe manner.

Two versions of the LED arrangement are provided. The circular arrangement provides a narrow spot beam. The array provides a wider beam. For details contact our lighting design section.

2.0 Storage

Luminaires are to be stored in cool dry conditions preventing ingress of moisture and condensation.

Any specific instructions concerning emergency luminaires must be complied with.

Battery Packs have a maximum shelf life of 1 year without a charging/discharge cycle.

Therefore if the fittings are to be stored for longer than 6 months, we recommend that the procedure listed should be followed to ensure full battery capacity is maintained and operation of the fitting every 6 -9 months during storage. Open Terminal Chamber and remove link comb between R1 & R2, connect mains power and energise the mains for an hour or more for 24 hours. Switch off the mains and the LED's will go on, the duration should be 90 or 180 minutes minimum depending on version. Re energise the mains voltage for 24 hours or more to fully charge batteries. Isolate mains supply and immediately fit link comb between R1 & R2, remove mains cable and close terminal chamber.

3.0 Installation and Safety

3.1 General

There is no health hazards associated with this product whilst in normal use. However, care should be exercised during the following operations. Installation should be carried out in accordance with (IEC) EN 60079-14 or the local hazardous area code of practice, whichever is appropriate.

In the UK the requirements of the "*Health and Safety at Work Act*" must be met.

Handling and electrical work associated with this product to be in accordance with *the "Manual Handling Operations Regulations"* and "*Electricity at Work Regulations, 1989*". Your attention is drawn to the paragraphs (i) 'Electrical Supplies', (ii) 'Electrical Fault Finding and Replacement' and (iii) 'Inspection and Maintenance'. The luminaires are Class 1 and should be effectively earthed.

The luminaires are quite heavy and suitable means of handling on installation must be provided.

Certification details on the rating plate must be verified against the application requirements before installation.

The information in this leaflet is correct at the time of publication. The company reserves the right to make specification changes as required.

3.1.1 Use in Combustible Dust Atmospheres

Where the SOLAS is used in ignitable dust atmospheres reference must be made to the selection and installation standards in order that the equipment is used correctly. In particular this applies to the de-rating of surface temperature for use where dust clouds may be present. Dust layers should not be allowed to accumulate on the fitting surface and good housekeeping is required for safe operation. Dust in layers has the potential to form ignitable clouds and to burn at lower temperatures.

Refer to (IEC) EN 60079-10-2 & (IEC) EN 61241-14 for additional details of selection, installation and maintenance.

3.1.2 Hybrid Mixtures – Gas plus Dust.

Where Hybrid mixtures exist as defined in EN1127 as a potentially explosive atmosphere, consideration should be given to verifying that the maximum surface temperature of the SOLAS is below the ignition temperature of the hybrid mixture.

3.2 Tools

5mm A/F socket keys.

4mm flat blade screwdriver.

19mm A/F spanners.

Suitable spanners for installation of cable glands.

Pliers, knife, wire strippers/cutters.

3.3 Electrical Supplies

The charging system will accept rated voltages of 220 to 254V or alternatively 100 to 130V 50 or 60Hz

A maximum nominal variation from this is +/-6%. The safety limit for T rating is +10%.

3.4 Light Source

This product is fitted with LED's that can last 60,000 hours depending on ambient temperatures. Therefore depending on the functionality of the fitting replacement of LED's will be rare /unnecessary. If the LED assembly needs replaced refer to **5.0 LED Replacement**.

3.5 Emergency Operation

When the mains voltage is on, the battery is charged. Indicator LED's will illuminate if the fitting is charging or is fully charged.

The fitting can be either maintained or non-maintained with a 90 minute fully power emergency duration or 180 minute half power emergency duration (both when specified can't retrospectively be changed).

Emergency inhibition is standard to allow the emergency light to be used only when required.

i.e. as an abandonment light.

3.5.1 Emergency Operation at -40 to -55 deg C.

If the fitting is left without mains voltage after battery discharge (emergency function) for 12 hours or more it will result in a time delay to the charging regime when the mains voltage is available.

At -40 deg C there will be a delay of approx 45 minutes.

At -55 deg C there will be a delay of approx 65 minutes.

This is allowing the battery heater to raise the temperature of the batteries to accept the charge this is further indicated with the green LED starting to flash indicating that the batteries are charging, a further 24 hours will be required to achieve full charge.

3.6 Mounting

Luminaires should be mounted where it is possible to gain access for maintenance and in accordance with any lighting design information provided for the installation. This will usually consist of aiming points and aiming angles.

The top mounting or trunnion mounting arrangements should be secured with lock washers or self-locking nuts and bolts.

3.7 Cabling and Cable Glands

3.7.1 Cable Glands

The installer and user take responsibility for the selection of cables, cable glands and seals.

The product is certified for ATEX and to comply with the certification for installation and use within the EU, cable glands and sealing plugs must have ATEX component approval.

For installation outside the EU, suitable cable glands in accordance with (IEC) EN 60079-0 will meet the technical requirements.

The cable and gland assembly when installed must maintain the IP66/67 rating of the luminaire.

The cable gland must withstand an impact value of 7Nm where the risk of mechanical damage is high or 4Nm where the risk of mechanical damage is low.

The cable gland when fitted must a minimum of 6mm clearance from the Exe terminal block.

Sealing plugs must be similarly rated and a tool must be used for their removal. Where the cable is not reliably clamped externally to the apparatus, the cable gland must clamp the cable against a pull in Newton's of 20 x the cable OD in mm for non-armoured cable and 80 x the cable OD for armoured cable. Where brass cable glands are used in a corrosive environment cadmium or nickel plating should be used. Two tapped cable entries are provided, one with a plug and seal suitable for permanent use, the other has a travelling plug. M20 x 1.5 entries are standard, M25 x 1.5 entries optional.

3.7.2 Cable

The temperature ratings of the entries are suitable for ordinary PVC cable (70°C). Users may wish to use fire resistant cables of 1.5mm²).

3.7.3 Cable Connection

The cable connections are made by removing the terminal chamber cover. The retaining screws are captive and should be re-greased as required. No more than one single or multiple strand lead shall be connected into either side of any terminal, unless multiple conductors have been joined in a suitable manner, e.g. two conductors into a single insulated crimped bootlace ferrule. Leads connected to the terminals shall be insulated for at least 275v and this insulation shall extend to within 1mm of the metal of the terminal throat. All terminal screws, used and unused, shall be tightened down to between 1.2 Nm and 2 Nm. The core must be identified by polarity and connected in accordance with the terminal markings. Before re-fitting the cover, a final check on the correctness of connections should be made. Ex e cover bolt torque 6Nm.

4.0 Commissioning

The luminaire always has the option to be connection to a remote switch, for control of emergency operation. Inside the Exe terminal box you will see two white sleeved cables, one with a black sleeve, connected into the terminal block these are the inhibition wires, supplied and fitted with a comb or link (fitted for transit only). **The comb or link must be removed** to allow the fitting to work in emergency mode when mains voltage fails. If the inhibition function is to be used connect to a remote inhibition switch. **This is a signal connection to and from control unit, no power should be connected to the R1 & R2 terminals.** If one switch is to operate a number of fittings, then wires connected to R1 & R2 terminals must not be crossed.

Following the wiring up and checking of the equipment, the operation is checked when the mains supply becomes available. Energise the mains for an hour or more. Switch off the mains and run fitting till it goes out.

Re-energise the mains supply for 24 hours. Switch off the mains and the LED's will go on (unless fitted with inhibition switch, circuit open - emergency operation, circuit closed - emergency inhibited). The duration should

be 90 or 180 minutes minimum depending on what was specified. If the mains voltage is still available re-energise the mains supply for 24 hours or more to fully charge batteries.

Once commissioning is complete with fully charged batteries and if the fitting is to be de-energised (no mains present) for a period greater than a month, then a link should be fitted across terminals R1 & R2, unless an inhibition switch is connected across terminals - then the switch should be closed. This will prevent the battery pack from discharging, therefore will maintain a sufficient charge to avoid deep discharge occurring.

5.0 LED Replacement.

The need and frequency of replacing LED's be dependent on the functionality of the fitting. If it is running as a maintained or non-maintained unit and if it is continually running at high ambient temperatures these will affect the frequency of LED replacement. If it is necessary to replace the LED's, all the LED's will be replaced as an assembly mounted on an aluminium back plate. The full assembly supplied by Chalmit.

The area should be gas free, (this is because there are un-assessed electronic components in the unit and these could retain stored energy). Release the front cover, before letting the cover hang check that the securing chain is secure and in good condition.

Removal of LED assembly is as follows:

1. Unscrew 6 off M3 screws that secure the aluminium plate to the case.
2. Carefully remove the red and green indicating LED's from the plate (retain as these will be used).
3. Disconnect the LED + and – wires from the terminal block.

Replacement of LED assembly is the reverse of the removal. Take care that the + and – wires from the assembly are connected correctly into the terminal block.

The flameproof path should have a generous coat of silicone (*Dow Corning Molykote III* or similar), or other protective non-setting grease. Replace all bolts and fully tighten. Torque to 16Nm.

6.0 Electrical fault finding and Replacement

Any fault finding must be done by a competent electrician with the luminaire isolated and if carried out with the luminaire in place, under a permit to work. Fault finding is by substitution with known good components.

7.0 Inspection and Maintenance

Individual organisations will have their own procedures for inspection and maintenance. What follows are guidelines based on (IEC) EN60079-17 and on our experience. Maintenance work and fault finding must be performed by competent personnel under an appropriate permit to work and with the apparatus isolated. Frequency of maintenance will depend on experience and the operating conditions.

Luminaire should not be opened when an explosive atmosphere is present.

- 1 Check if any LED's have failed (do not light).
- 2 If there is 7 or more not working the light output will have dropped to a level the LED assembly may need replaced. Refer to 5.0 LED Replacement.
- 3 Check the luminaire terminal chamber bolts for tightness. Torque to 6Nm.
- 4 Check the cable glands for tightness and nip if necessary.
- 5 Check any external earthing.
- 6 Examine the lamp glass for any signs of damage and for any signs of sealant damage, cracking or discoloration. If thought necessary, the silicone weather seal can be re-sealed with a proprietary brand of clear RTV silicone, but only if the underlying sealant is in good condition. Any damage to the glass the front glass cover assembly must be replaced. Check luminaire cover bolts for tightness. Torque to 16Nm.
- 7 Check for signs of corrosion between the front glass cover and main housing. Evaluation of this will be a matter of judgement and experience, as there may be little evidence on the outside. If there are serious signs of corrosion remove the cover, wipe the flameproof path with a clean cloth and non-metallic scrapper. Examine the surface for pitting any pitted component must be replaced. A damaged or non-resilient cover gasket must be replaced and bonded into groove. The cord diameter is 3mm.

The cover should be re-greased with silicone (*Dow Corning Molykote III* or any non-setting grease) and all bolts fully tightened. Any replacement bolts must be identical with the original.

All are 18/8 stainless steel with a minimum of ISO262 Grade A 2-70.

With this type of flameproof enclosure all the bolts must be in place and tightened. The maximum gap for IIB in this case is 0.15mm. It would be unusual for any of our luminaires to have a gap exceeding 0.1mm when tried with a feeler gauge. If 0.1mm is exceeded check that no foreign bodies or debris at the bottom of blank tapped holes are keeping the surfaces apart and if not, a workshop overhaul should be carried out

to bring the unit into new condition. Even if there are no signs of external corrosion the front cover should be removed at a minimum of every 3 years and the internal connections checked for tightness and any signs of overheating.

- 8 Examine the batteries for any signs of leakage or corrosion and if this has taken place the battery packs must be replaced. Refer to 5.0 LED Replacement (which will allow you to examine the batteries). Use only replaceable batter pack, SAFT battery pack Part No: 6VT FH 70 EX.
- 9 The terminal chamber should be opened periodically and checked for moisture ingress. The cable connections should be checked for tightness. The gasket should be checked for lack of elasticity and if necessary replaced and bonded into groove (it may well be practical to replace the gasket on each occasion if this is 2-3 year interval). Torque to 6Nm.
- 10 If painting operations have taken place near the luminaire ensure that coatings have not entered into the flameproof path or been deposited on the glass. If they have been, dismantle and clean carefully.
- 11 Check the mountings are secure.
- 12 Cover the bolt heads with silicone grease to prevent corrosion and the accumulation of dirt and screw threads.
- 13 Clean the glass.
- 14 If there is suspicion that the luminaire has suffered mechanical damage, a stringent workshop check should be made.

7.1 LED Indicator Logic Table

Condition	LED Status
Charging (Boost Charge)	Flashing Green
Fully Charged (Constant Trickle Charge)	Constant Green
Low Battery	Alternating Red & Green
Unable to Charge	Flashing Red
Battery Pack Unable to accept Charge	Flashing Red
Battery Fault	Flashing Red
Inhibition Function Activated & Charging	Red Flashing every 4 Secs & Flashing Green
Inhibition Function Activated & Fully Charged	Red Flashing every 4 Secs & Constant Green
Inhibition Function Activated & Power Off	Red & Green not Illuminated

8.0 Power and Current Ratings at 220-254V 50/60Hz

The power drawn by luminaire when charging:

Solas Emergency	Watts Boost charge No heater	Watts Constant charge No heater	Watts Boost charge with heater	Watts Constant charge with heater
maintained	83	75	120	114
Non-maintained	23	12	62	52
Normal Operation Non Emergency Version				
Solas	62	-	-	-

- Battery charging regime:
- a. 0.5 hours at C/20 (350mA)
 - b. 5 hours boost at C/10 (700mA)
 - c. constant charge C/20 (350mA)

Solas Emergency	Mains current. Amps	During 5 hour boost charge
Maintained with heater	0.6 – 0.46A	0.6 – 0.52A
Non-maintained with heater	0.28 – 0.21A	0.37 – 0.32A
Maintained without heater	0.39 – 0.33A	0.41 – 0.36A
Non-maintained without heater	0.07 – 0.06A	0.11 – 0.1A
Solas non-emergency	0.32 – 0.28A	-

For voltages between 100-130V 50/60Hz power values remain as shown, current values increase by x 2.

Fuse & MCB Rating:- Inrush current 60A - 100µs.

9.0 Disposal of Material

The units are chiefly made of incombustible material. The control gear contains electronic components and synthetic resin. All these may give off noxious fumes if incinerated. Care must be taken to render these fumes harmless and avoid inhalation. Any local regulations concerning disposal must be complied with. Any disposal must satisfy the requirements of the WEEE directive [2012/19/EU] and therefore must not be treated as commercial waste. The unit is mainly made from incombustible materials. The control gear contains plastic, resin and electronic components. All electrical components may give off noxious fumes if incinerated.

9.1 Battery Disposal

Nickel cadmium batteries are defined as 'controlled waste' under the hazardous waste regulations and the disposer needs to observe a 'duty of care'.

Batteries can be returned to the manufacturers for recycling. They must be stored and transported safely and any necessary pollution control forms completed prior to transportation. Take care to fully discharge batteries before transporting or otherwise ensure that there can be no release of stored energy in transit. For further details refer to our Technical Department.





To comply with the Waste Electrical and Electronic Equipment directive 2012/19/EU the apparatus cannot be classified as commercial waste and as such must be disposed of or recycled in such a manner as to reduce the environmental impact.

Chalmit Lighting is a leading supplier of Hazardous Area lighting products

	<p>CHALMIT LIGHTING PO Box 5575 Glasgow, G52 9AP Scotland</p>	
<p>Telephone: +44 (0) 141 882 5555 Fax: +44 (0) 141 883 3704 Email: info@chalmit.com Web: www.chalmit.com</p>	<p>Registered No: 669157 Registered Office: Cannon Place 78 Cannon Street London EC4N 6AF UK</p>	

For technical support, please contact: techsupport@chalmit.com

Note: Chalmit Lighting reserves the right to amend characteristics of our products and all data is for guidance only.

	EU-Declaration of conformity		
	UE-Déclaration de conformité		
	EU-Konformitätserklärung		
Manufacturer	Chalmit	Address	388 Hillington Road, Glasgow. G52 4BL Scotland UK
Product	Solas and Solas (Emergency) Luminaire.		
EU - Type Examination Certificate	Baseefa11ATEX0090		
Notified Body	SGS Fimko OY 0598		
ATEX Coding	 II 2 GD	ATEX Classification	Group II Category 2 GD
Equipment Coding	Ex db eb IIB T5 Gb, Ex tb IIIC T100°C Db IP6X		
Ingress Protection	IP66/67		
The technical basis, with respect to equivalence of			
La base technique, en ce qui concerne l'équivalence de			
Die technische Grundlage hinsichtlich der Normen			
Protection Standards EN 60079-0, EN 60079-1, EN 60079-7, EN 60079-31.			
Area Classification EN 60079-10-1 and EN 60079-10-2			
of compliance with the EHSRs is valid as there are no changes which materially affect the state of technological progress of the product.			
en conformité avec les EESS est valide puisqu'il n'y a aucun changement qui affecte matériellement l'état de l'évolution technologique du produit.			
zur Erfüllung der GSGA ist gegeben, da keine Änderungen erfolgt sind, die einen Einfluss auf den technischen Stand des Produkts haben.			
Terms of the directive:		Standard & Date Certified to	Standards Date Declared to
Prescription de la directive:		Standard & date certifiée à	Normes date Déclaré
Bestimmungen der Richtlinie:		Standard & Datum Zertifiziert nach	Standards Datum erklärt
2014/34/EU	Equipment and protective systems intended for use in potentially explosive atmospheres.	EN 60079-0: 2012	
		EN 60079-1: 2014	
2014/34/UE	Appareils et les systèmes de protection destinés à être utilisés en atmosphères potentiellement explosibles.	EN 60079-7: 2015	
		EN 60079-31: 2014	
2014/34/EU	Geräte und Schutzsysteme zur bestimmungsgemäßen Verwendung in explosionsfähigen Bereichen.		
2014/30/EU	Electromagnetic compatibility	EN 55015 : 2013	
2014/30/UE	Compatibilité électromagnétique	EN 61547 : 2009	
2014/30/EU	Elektromagnetische Verträglichkeit	EN 61000-3-2 : 2014	
2014/35/EU	Low voltage equipment	EN 60598-1 : 2015	
2014/35/UE	Équipements électriques à bas voltage	EN 60598-2-5 : 2015	
2014/35/EU	Niederspannungsgeräte / -systeme	EN 60598-2-22 : 2014	
		EN 60529 : 1992	
2012/19/EU	Waste of electrical and electronic equipment		
2012/19/UE	Déchets d'équipements électriques et électroniques		
2012/19/EU	Entsorgung der elektrischen und elektronischen Geräte / Systeme		
2011/65/EU	RoHS II Directive		



On behalf of the Chalmit, I declare that, on the date the equipment accompanied by this declaration is placed on the market, the equipment conforms to all technical and regulatory requirements of the above listed directives.

En tant que représentant du fabricant Chalmit, je déclare qu'à la date où les équipements accompagnant cette déclaration sont mis sur le marché, ceux-ci sont conformes à toutes les dispositions réglementaires et techniques des directives énumérées ci-dessus.

Hiermit bestätige ich, im Namen von Chalmit, dass am Tag der Lieferung des Produkts/der Produkte zusammen mit dieser Erklärung das Gerät/die Geräte alle technischen und regulativen Anforderungen der oben aufgeführten Direktiven erfüllt.

Name and Date Mark Poutney 01/01/2021
Nom et Date
Name und Datum

Technical Manager
Directeur technique
Technischer Leiter

Quality Assurance Notification by: **SGS Fimko OY**
Notification d'assurance qualité par: **0598**
Qualitätssicherungsnotifikation durch:

Quality Management System Accreditation:
Système de Management Qualité Accréditation:
Qualitätsmanagementsystem Akkreditierung:
Environmental Management System.
Système de gestion de l'environnement.
Umwelt kontroll system.
Certificate No./Certificat N°/Zertifikat Nr.

ISO 9001

ISO 14001
by/par/durch
Loyd's Register
LRQ 4005876