



NetSure™ -48 VDC Distribution Cabinet Assembly

Installation and User Manual

Specification Number: 548066 (19"W), 548067 (23"W), 561569 (23"W)

The information contained in this document is subject to change without notice and may not be suitable for all applications. While every precaution has been taken to ensure the accuracy and completeness of this document, Vertiv assumes no responsibility and disclaims all liability for damages resulting from use of this information or for any errors or omissions. Refer to other local practices or building codes as applicable for the correct methods, tools, and materials to be used in performing procedures not specifically described in this document.

The products covered by this instruction manual are manufactured and/or sold by Vertiv. This document is the property of Vertiv and contains confidential and proprietary information owned by Vertiv. Any copying, use or disclosure of it without the written permission of Vertiv is strictly prohibited.

Names of companies and products are trademarks or registered trademarks of the respective companies. Any questions regarding usage of trademark names should be directed to the original manufacturer.

Technical Support Site

If you encounter any installation or operational issues with your product, check the pertinent section of this manual to see if the issue can be resolved by following outlined procedures.

Visit <https://www.vertiv.com/en-us/support/> for additional assistance.

TABLE OF CONTENTS

Admonishments Used in this Document	iv
Important Safety Instructions	v
Static Warning	vi
1 Description	1
2 Specifications	1
2.1 Electrical.....	1
2.2 Environmental.....	1
2.3 Dimensions.....	1
2.4 Compliance Information.....	1
3 Accessories	4
3.1 Optional Rear Feed Input Busbar Kit.....	4
3.2 Distribution Devices	4
3.3 Recommended Wire Sizes and Lugs.....	8
3.4 Special Application Lugs, Busbar Adapter Kits and Hardware Kits.....	12
4 Installation	14
4.1 Safety Statements.....	14
4.2 Mounting the Cabinet.....	14
4.3 Installing Distribution Devices	14
4.4 Electrical Connections	17
4.5 Initial Startup.....	22
5 Operation	23
5.1 Indicators	23
6 Troubleshooting and Repair	24
6.1 TPS/TLS Type Fuse Replacement.....	24
6.2 Bullet Nose Type Fuseholder Replacement.....	24
6.3 Circuit Breaker Replacement.....	25

Admonishments Used in this Document



DANGER! Warns of a hazard the reader *will* be exposed to that will *likely* result in death or serious injury if not avoided. (ANSI, OSHA)



WARNING! Warns of a potential hazard the reader *may* be exposed to that *could* result in death or serious injury if not avoided. This admonition is not used for situations that pose a risk only to equipment, software, data, or service. (ANSI)



CAUTION! Warns of a potential hazard the reader *may* be exposed to that *could* result in minor or moderate injury if not avoided. (ANSI, OSHA) This admonition is not used for situations that pose a risk only to equipment, data, or service, even if such use appears to be permitted in some of the applicable standards. (OSHA)



ALERT! Alerts the reader to an action that *must be avoided* in order to protect equipment, software, data, or service. (ISO)



ALERT! Alerts the reader to an action that *must be performed* in order to prevent equipment damage, software corruption, data loss, or service interruption. (ISO)



FIRE SAFETY! Informs the reader of fire safety information, reminders, precautions, or policies, or of the locations of fire-fighting and fire-safety equipment. (ISO)



SAFETY! Informs the reader of general safety information, reminders, precautions, or policies not related to a particular source of hazard or to fire safety. (ISO, ANSI, OSHA)

Important Safety Instructions

Safety Admonishments Definitions

Definitions of the safety admonishments used in this document are listed under “Admonishments Used in this Document” on page iv.

General Safety



DANGER! YOU MUST FOLLOW APPROVED SAFETY PROCEDURES.

Performing the following procedures may expose you to hazards. These procedures should be performed by qualified technicians familiar with the hazards associated with this type of equipment. These hazards may include shock, energy, and/or burns. To avoid these hazards:

- a) The tasks should be performed in the order indicated.
- b) Remove watches, rings, and other metal objects.
- c) Prior to contacting any uninsulated surface or termination, use a voltmeter to verify that no voltage or the expected voltage is present. Check for voltage with both AC and DC voltmeters prior to making contact.
- d) Wear eye protection.
- e) Use certified and well maintained insulated tools. Use double insulated tools appropriately rated for the work to be performed.

Personal Protective Equipment (PPE)



DANGER! ARC FLASH AND SHOCK HAZARD.

Appropriate PPE and tools required when working on this equipment. An appropriate flash protection boundary analysis should be done to determine the “hazard/risk” category, and to select proper PPE.



Only authorized and properly trained personnel should be allowed to install, inspect, operate, or maintain the equipment.

Do not work on LIVE parts. If required to work or operate live parts, obtain appropriate Energized Work Permits as required by the local authority, per NFPA 70E “Standard for Electrical Safety in the Workplace”.

Handling Equipment Containing Static Sensitive Components



ALERT! Installation or removal of equipment containing static sensitive components requires careful handling. Before handling any equipment containing static sensitive components, read and follow the instructions contained on the Static Warning Page.

Static Warning



This equipment contains static sensitive components. The warnings listed below must be observed to prevent damage to these components. Disregarding any of these warnings may result in personal injury or damage to the equipment.

1. Strictly adhere to the procedures provided in this document.
2. Before touching any equipment containing static sensitive components, discharge all static electricity from yourself by wearing a wrist strap grounded through a one megohm resistor. Some wrist straps have a built-in one megohm resistor; no external resistor is necessary. Read and follow wrist strap manufacturer's instructions outlining use of a specific wrist strap.
3. Do not touch traces or components on equipment containing static sensitive components. Handle equipment containing static sensitive components only by the edges that do not have connector pads.
4. After removing equipment containing static sensitive components, place the equipment only on static dissipative surfaces such as conductive foam or ESD bag. Do not use ordinary Styrofoam or ordinary plastic.
5. Store and ship equipment containing static sensitive components only in static shielding containers.
6. If necessary to repair equipment containing static sensitive components, wear an appropriately grounded wrist strap, work on a conductive surface, use a grounded soldering iron, and use grounded test equipment.

1 Description

Spec. No. 548066 is a -48 VDC Distribution Cabinet Assembly, which accepts up to nineteen (19) TPS/TLS-Type Fuses (3 to 100A) or Bullet Nose Type Circuit Breakers (1 to 250A). The assembly is designed for mounting in a 19" relay rack. This Distribution Cabinet Assembly is designed for use in -48 VDC systems.

Spec. No. 548067 and 561569 is a -48 VDC Distribution Cabinet Assembly, which accepts up to twenty four (24) TPS/TLS-Type Fuses (3 to 100A) or Bullet Nose Type Circuit Breakers (1 to 250A). The assembly is designed for mounting in a 23" relay rack. This Distribution Cabinet Assembly is designed for use in -48 VDC systems.

Spec. No. 561569 is the same as Spec. No. 548067 except no top and top/rear covers provided, no hardware provided on DC input terminations, and right angle lug adapter P/N 545405 factory furnished and installed on all distribution positions.

Kit P/N 10012729 provides Spec. No. 548066 Distribution Cabinet Assembly and right angle lug adapter P/N 545405 factory furnished and installed on all distribution positions.

Kit P/N 10009822 provides Spec. No. 548067 Distribution Cabinet Assembly and right angle lug adapter P/N 545405 factory furnished and installed on all distribution positions.

2 Specifications

2.1 Electrical

- Input/Output Voltage: Nominal -48 VDC.
- Current Ratings:
 - 400 A at 40 °C ambient temperature.
 - 300 A at 65 °C ambient temperature.
- Circuit Breaker / Fuse Alarm Circuit: Resistive battery is provided to an alarm lead if one or more distribution fuses open.
- Shunt: 600 A, 25 mV. Output is available through 12 ft., 22 AWG leads in a twisted pair. Each lead is protected by one (1) 49.9 ohm resistor.

2.2 Environmental

- Operating Temperature Range: -40 °C to +65 °C (-40 °F to +149 °F).
- Storage Temperature Range: -40 °C to +85 °C (-40 °F to +185 °F).
- Humidity: Capable of operating in an ambient relative humidity range of 0 % to 95 %, non-condensing.
- Altitude: Will operate at any elevation between sea level and 10,000 ft.

2.3 Dimensions

- See Figure 2.1 (19") and Figure 2.2 (23").

2.4 Compliance Information

- Safety Compliance: This DC Power Distribution Cabinet is UL Listed as a DC Power Distribution Center for Communications Equipment.

Figure 2.1 Dimensions of Spec. No. 548066 (19"W)

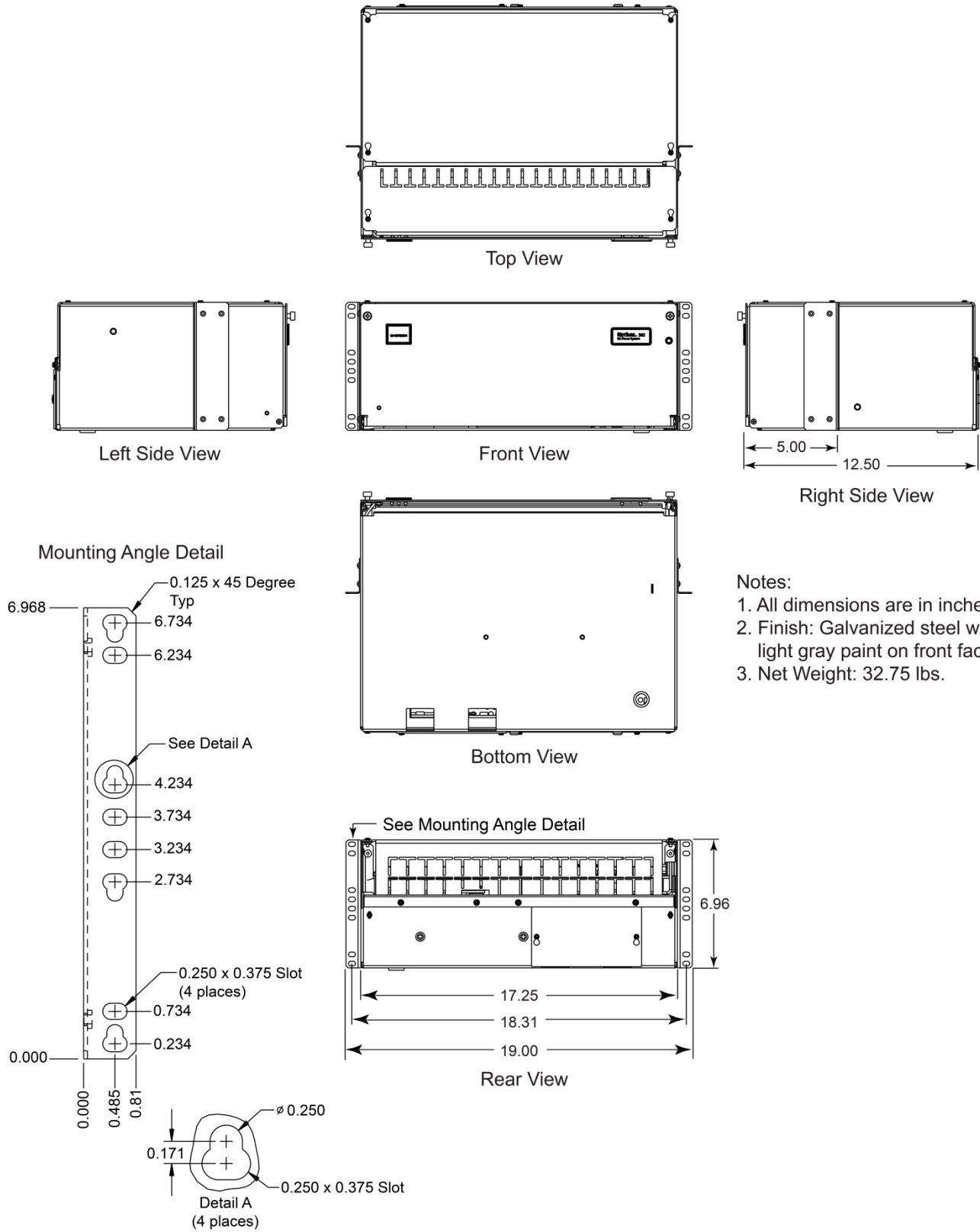
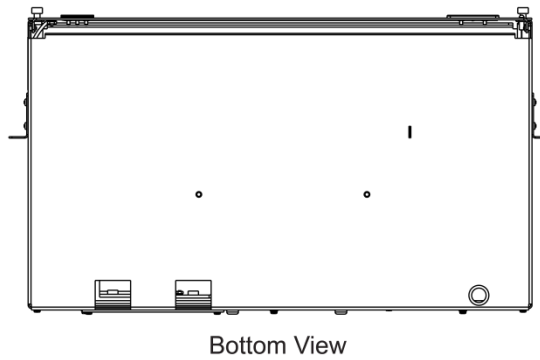
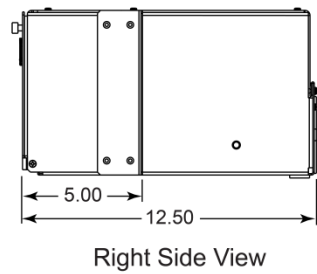
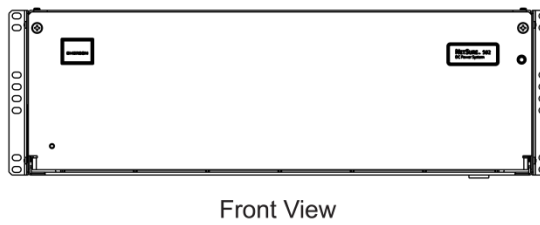
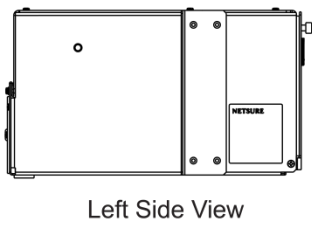
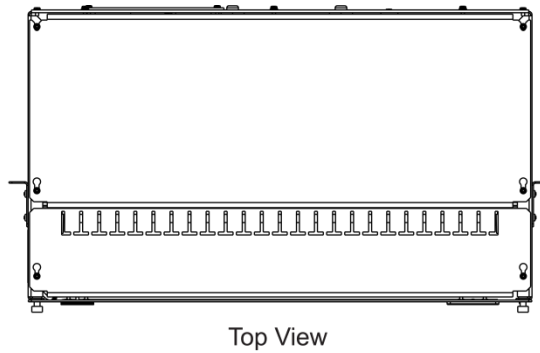
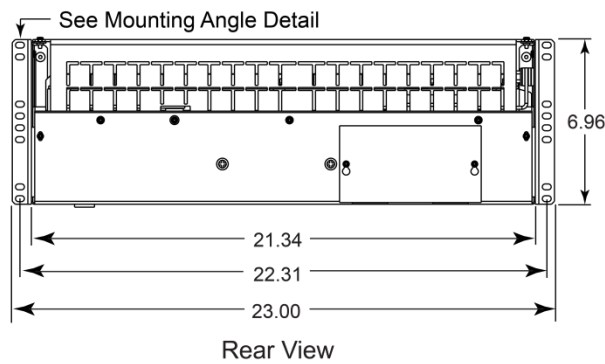
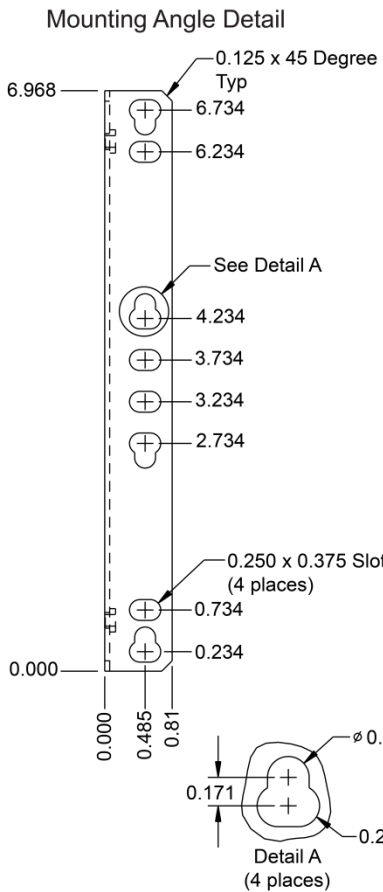

Figure 2.2 Dimensions of Spec. No. 548067 and 561569 (23"W)

Spec. No. 548067 shown.
 Spec. No. 561569 same except
 no top or top/rear cover provided.



- Notes:
1. All dimensions are in inches.
 2. Finish: Galvanized steel with light gray paint on front face.
 3. Net Weight: 37.75 lbs.



3 Accessories

3.1 Optional Rear Feed Input Busbar Kit

Features

- Provides two (2) busbars, covers and installation hardware to convert Distribution Cabinet from top input connections (horizontal lugs) to rear input connections (vertical lugs).
- Unless otherwise specified, kits are factory-installed when ordered with cabinet, or can be field-installed when ordered separately.

Ordering Notes

1. Order kit Part No. 548090 for 19" cabinets.
2. Order kit Part No. 548126 for 23" cabinets.

3.2 Distribution Devices

TPS/TLS-Type Fuses

Features

- A single fuseholder provides for installation of a 3 to 100 ampere Bussmann TPS-type or Littelfuse TLS-type fuse. This fuseholder plugs into a single mounting position. This fuseholder includes a GMT-A alarm type fuse, which operates open to provide an alarm indication if the distribution fuse opens.
- Unless otherwise specified, fuseholders and fuses are factory-installed when ordered with cabinet, and can be field-installed when ordered separately.

Ordering Notes

1. Order fuses per Table 3.1.



NOTE! Load should not exceed 80% of device rating.

2. Order one (1) Part No. 117201 TPS/TLS-type fuse holder for each fuse.
3. For lug and wire size selection, refer to Table 3.5.

Bullet Nose Type Circuit Breakers

Features

- Circuit breaker with values of 1A through 100A plug into a single mounting position; values of 125A, 175A and 200A occupy 2 positions; and value of 250A occupies 3 positions.
- Unless otherwise specified, circuit breakers are field-installed when ordered separately.

Restrictions

In a +40 °C ambient, 100 A circuit breakers can be used without a space provided the continuous current in each device does not exceed 64 A. Overcurrent protective devices greater than 100 A shall have an empty mounting position between it and any other overcurrent protective device.

At or above +65 °C, the maximum size overcurrent device used shall be 70 A. Devices rated at 70 A or less shall have an empty mounting position between it and any other overcurrent protective device.

Ordering Notes

1. Order circuit breakers, as required, per Table 3.2.



NOTE! Load should not exceed 80% of device rating.

2. For lug and wire size selection, refer to Table 3.5.

GMT Distribution Fuse Assembly Kit (Part No. 545333)**Features**

- Mounts in (2) distribution positions of the Distribution Cabinet.
- Provides (6) Load Distribution Fuse Positions (0.25 to 15A GMT Alarm-Type Fuses)
- Screw clamp type terminals
- Includes (6) dummy fuses equipped with safety fuse covers.
- Unless otherwise specified, kit is field-installed when ordered separately.

Restrictions

At 40 °C ambient, any GMT fuse greater than 10A **SHALL HAVE** an empty mounting position between it and any other fuse. At 65 °C ambient, any GMT fuse greater than 3A **SHALL HAVE** an empty mounting position between it and any other fuse.

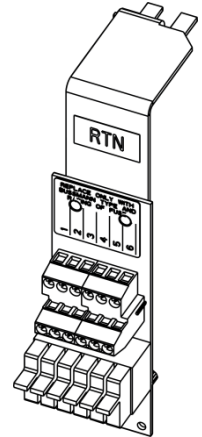

Cannot be installed in the following positions (counting from left-hand side):

- 19" Cabinet: Positions 3, 4, 5, 9 or 10
- 23" Cabinet: Positions 3, 4, 5, 12 or 13

When field installed assembly should be installed starting at the left hand side of the panel.

Maximum size of wire to be connected to a single fuse position is 14 AWG.

Ordering Notes

1. Order Part No. 545333 Kit. Provides one GMT fuse distribution assembly, ground return link, and hardware.
2. Order fuses, as required, per Table 3.3.

Table 3.1

TPS/TLS-TYPE FUSES	
AMPERE RATING	PART NUMBER
3	248230900
5	248231000
6	248231200
10	248231500
15	248231800
20	248232100
25	248232400
30	248232700
40	248233300
50	248233900
60	248234200
70	248234500
80	118413
90	118414
100	118415
TPS/TLS-Type Fuseholder*	117201

Fuseholders are not furnished and must be ordered as required. Order (1) Part No. 117201 for each fuse position required. Fuseholder includes (1) alarm fuse (Bussmann GMT-A 18/100 amp; Vertiv Co. 248610301) and (1) alarm fuse safety cover (Part No. 248898700).

Fuses are to be mounted from right to left starting with the highest capacity and working to the lowest capacity.

Table 3.2

BULLET NOSE TYPE CIRCUIT BREAKERS			
AMPERE RATING	NUMBER OF MTG. POSITIONS	PART NUMBER Electrical/ Mechanical Trip ¹ (Black Handle)	PART NUMBER Electrical Trip ² (White Handle)
1	1	101596	102272
3	1	101597	102273
5	1	101598	102274
10	1	101599	102275
15	1	101600	102276
20	1	101601	102277
25	1	101602	102278
30	1	101603	102279
35	1	101604	102280
40	1	101605	102281
45	1	121997	121998
50	1	101606	102282
60	1	101607	102283
70	1	101608	102284
75	1	101609	102285
80	1	121995	121996
100	1	101610	102286
125	2	516838	516991
150	2	516839	516993
200	2	121832	121831
250	3	121836	121835

Circuit Breaker Alarm Operation:

¹ Provides an alarm during an electrical or manual trip condition.

² Provides an alarm during an electrical trip condition only.

Breakers are to be mounted from right to left starting with the highest capacity and working to the lowest capacity.

For 2-pole devices, either order lugs from Table 3.6 or adapter kit 545404 and lugs from Table 3.5.

For 3-pole devices, order adapter kit 545571 and lugs from Table 3.5.

Table 3.3 GMT Fuses

Ampere Rating	Part Number	Fuse Color
18/100 GMT-A	248610301	--
1/4	248610200	Violet
1/2	248610300	Red
3/4	248610500	Brown
1-1/3	248610700	White
2	248610800	Orange
3	248610900	Blue
5	248611000	Green
7-1/2	248611300	Black-White
10	248611200	Red-White
15	248611500	Red-Blue
Replacement Dummy Fuse	248872600	--
Replacement Safety Fuse Cover	102774	--



NOTE! When using these fuses for power distribution, load should not exceed 80% of device rating, except 10 and 15 amp fuses, for which load should not exceed 70% of device rating.

3.3 Recommended Wire Sizes and Lugs

DC Input Conductors

Features

- The Distribution Cabinet is designed for connection of lug-terminated input conductors to busbars located on the top of the unit (horizontal lugs). Busbars provide 3/8-16 threaded studs on 1" centers for installation of customer-furnished two-hole lugs. For Spec. No. 548066 and 548067, factory provides lug-mounting hardware. For Spec. No. 561569, customer to provide lug mounting hardware.
- For lug spacing dimensions, refer to Figure 4.4 and Figure 4.5.

Ordering Notes

1. All lugs for customer connections must be ordered separately.
2. For wire size and lug selection, refer to Table 3.4.
3. Lugs should be crimped to the specifications given in the manufacturer's instructions furnished with the crimp tool or lugs.

Table 3.4

Max. Total Input Curr. (Amps)	Ambient Operating Temp. ⁽¹⁾	Loop Length (Ft.) 1.0 Volt Drop ⁽²⁾	Recm. 90°C Wire Size	Recm. Crimp Lug ⁽³⁾
400A	40 °C	75	(2) 3/0 AWG	(2) 245347300
		95	(2) 4/0 kcmil	(2) 245347400
		112	(2) 250 kcmil	(2) 245347500
300A	65 °C	157	(2) 350 kcmil	(2) 245347700
		180	(2) 400 kcmil	(2) 245347800
		225	(2) 500 kcmil	(2) 245347900

1. Wire sizes are based on recommendations of the American National Standards Institute (ANSI) approved National Fire Protection Association's (NFPA) National Electrical Code (NEC). Table 310-16 for copper wire rated at 90 °C conductor temperature operating in ambient temperatures of 40 °C and 65 °C was used. For other operating ambient temperatures, refer to the NEC. For operation in countries where the NEC is not recognized, follow applicable codes.
2. Recommended wire sizes are sufficient to restrict maximum voltage drop to 1.0 volt at rated full load output current of the shelf for the loop lengths shown in this column. Loop length is the sum of the lengths of the positive and negative leads. See also Table 15 for SAG582136800 – Issue T for reference.
3. Two-hole lug, 3/8" bolt clearance hole, 1" centers. Lugs should be crimped per lug manufacturer's specifications.

DC Load Conductors

Features

- The Distribution Cabinet is designed for connection of lug-terminated load conductors to the distribution fuseholder or circuit breaker mounting positions and the ground busbar. All provide 1/4-20 threaded studs on 5/8" centers for installation of customer-furnished two-hole lugs. Customer to provide lug mounting hardware. (See Table 3.7 for an available hardware kit.)
- For lug spacing dimensions, refer to Figure 4.6.
- Note that right angle lug adapter P/N 545405 is factory furnished and installed on all load distribution positions for Spec. No. 561569, kit P/N 10009822, and kit P/N 10012729.

Restrictions

All lugs for customer connections must be ordered separately.

Maximum allowed size of wire per distribution position is 2 AWG.

Ordering Notes

1. The rating of the distribution device determines the wire size requirements. For wire size and lug selection, refer to Table 3.5.
2. Lugs should be crimped to the specifications given in the manufacturer's instructions furnished with the crimp tool or lugs.

Table 3.5 Recommended Distribution (Load) Wire Size and Lug Selection for TLS/TPS Fuse and Bullet Nose-Type Circuit Breaker (Load and Load Return) (cont'd on next page)

Fuse/Circuit Breaker Amperage	Recm 90 °C Wire Size ⁽¹⁾						
	14 AWG	12 AWG	10 AWG	8 AWG	6 AWG	4 AWG	2 AWG
	Loop Length (feet) ⁽²⁾						
1, 3, 5, 6, 10A	37 ^(3,4,5)	58 ^(3,4,5)	93 ^(3,4,5)	148 ^(3,4,5)	236 ^(3,4,5)	376 ^(3,4,5)	597 ^(3,4,5)
15A	24 ^(3,4)	39 ^(3,4,5)	62 ^(3,4,5)	99 ^(3,4,5)	157 ^(3,4,5)	250 ^(3,4,5)	398 ^(3,4,5)
20A	--	29 ^(3,4)	46 ^(3,4,5)	74 ^(3,4,5)	118 ^(3,4,5)	188 ^(3,4,5)	298 ^(3,4,5)
25A	--	--	37 ^(3,4)	59 ^(3,4,5)	94 ^(3,4,5)	150 ^(3,4,5)	239 ^(3,4,5)
30A	--	--	31 ^(3,4)	49 ^(3,4,5)	78 ^(3,4,5)	125 ^(3,4,5)	199 ^(3,4,5)
35A	--	--	--	42 ^(3,4)	67 ^(3,4,5)	107 ^(3,4,5)	170 ^(3,4,5)
40A	--	--	--	37 ^(3,4)	59 ^(3,4,5)	94 ^(3,4,5)	149 ^(3,4,5)
45A	--	--	--	33 ^(3,4)	52 ^(3,4)	83 ^(3,4)	132 ^(3,4)
50A	--	--	--	29 ⁽³⁾	47 ^(3,4)	75 ^(3,4)	119 ^(3,4)
60A	--	--	--	--	39 ^(3,4)	62 ^(3,4)	99 ^(3,4)
70A	--	--	--	--	--	53 ^(3,4)	85 ^(3,4)
75A	--	--	--	--	--	50 ^(3,4)	79 ^(3,4)
80A	--	--	--	--	--	47 ⁽³⁾	74 ^(3,4)
Recommended Crimp Lug ⁽⁶⁾							
Lug (two-hole)	245342300	245342300	245342300	245390200	245346700	245346800	245346900

Table 3.5 Recommended Distribution (Load) Wire Size and Lug Selection for TLS/TPS Fuse and Bullet Nose-Type Circuit Breaker (Load and Load Return) (cont'd from previous page)

Fuse/Circuit Breaker Amperage	Recm 90 °C Wire Size ⁽¹⁾						
	2 AWG	1/0 AWG	2/0 AWG	3/0 AWG	4/0 AWG	250 kcmil	350 kcmil
	Loop Length (feet) ⁽²⁾						
90A	66 ^(3,4)	105 ⁽³⁾	133 ⁽³⁾	--	--	--	--
100A	59 ^(3,4)	95 ⁽³⁾	119 ⁽³⁾	--	--	--	--
125A	47 ⁽³⁾	76 ⁽³⁾	95 ⁽³⁾	120 ⁽³⁾	--	--	--
150A	--	63 ⁽³⁾	79 ⁽³⁾	100 ⁽³⁾	--	--	--
200A	--	--	--	75 ⁽³⁾	--	--	--
250A	--	--	--	--	--	--	--
Recommended Crimp Lug ⁽⁶⁾							
Lug (two-hole)	245346900	245393500 ⁽⁷⁾	245393600 ⁽⁷⁾	245393700 ⁽⁷⁾	245393800 ⁽⁷⁾	514872 ⁽⁷⁾	514873 ⁽⁷⁾

Notes to Table 3.5:

- Wire sizes are based on recommendations of the American National Standards Institute (ANSI) approved National Fire Protection Association's (NFPA) National Electrical Code (NEC). Table 310-16 for wire rated at 90 °C conductor temperature operating in ambient temperatures of 40 °C, 50 °C, and 65 °C was used. For other operating ambient temperatures, refer to the NEC. For operation in countries where the NEC is not recognized, follow applicable codes.
- Recommended wire sizes are sufficient to restrict voltage drop to 1.0 volt or less at listed branch current for the loop lengths shown. Loop length is the sum of the lengths of the positive and negative leads.
- Wire Size / Loop Length Combination Calculated using 40 °C Ambient Operating Temperature.
- Wire Size / Loop Length Combination Calculated using 50 °C Ambient Operating Temperature.
- Wire Size / Loop Length Combination Calculated using 65 °C Ambient Operating Temperature.
- Load lugs are two-hole for 1/4" bolt clearance on 5/8" centers. Lugs should be crimped per lug manufacturer's specifications.
- Special application crimp lug / strap combination. See Table 3.6.

3.4 Special Application Lugs, Busbar Adapter Kits and Hardware Kits

Special Application Lugs

Features

- Lug connects one (1) cable to two (2) distribution positions. 1/4" bolt clearance holes on 5/8" centers.
- See Table 3.6 for part numbers for various cable sizes.

Table 3.6

Lead Size	Part Number
1/0 AWG	245393500
2/0 AWG	245393600
3/0 AWG	245393700
4/0 AWG	245393800
250 kcmil	514872
350 kcmil	514873

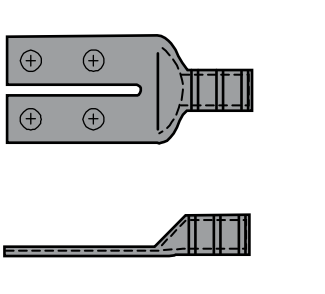

Busbar Adapter and Hardware Kits

Features

- See Table 3.7 for part numbers and descriptions of available kits.
- Kits include hardware shown.
- Unless otherwise specified, Busbar Adapter Kits can be field-installed when ordered separately.
- Note that right angle lug adapter P/N 545405 is factory furnished and installed on all load distribution positions for Spec. No. 561569, kit P/N 10009822, and kit P/N 10012729.

Table 3.7

Part Number	Description
545405	Busbar Adapter Kit – Converts (1) load position (1/4-20, 5/8" centers) to (1) load landing (1/4-20, 5/8" centers), right angle.
545404	Busbar Adapter Kit – Converts (2) load positions (1/4-20, 5/8" centers) to (1) landing (3/8-16, 1" centers), right angle.
545571	Busbar Adapter Kit – Converts (3) load positions (1/4-20, 5/8" centers) to (1) landing (3/8-16, 1" centers), right angle.
545412	Lug Hardware kit – (4) 1/4-20 nuts, lock washers and flat washers.
10013376	Lug Hardware kit – (38) 1/4-20 nuts, lock washers and flat washers.

545405 545404 545571 545412 10013376

4 Installation

4.1 Safety Statements



DANGER! Installation of this equipment should only be performed by a qualified installer following approved safety procedures. If a qualified technician is not available, arrangements can be made with Vertiv Co. to have the equipment installed.



DANGER! This equipment operates from battery. Batteries are an energy source that can produce high amounts of electrical current. NEVER allow a metal object, such as a tool, to contact more than one energized termination at a time, or to simultaneously contact an energized termination and a grounded object. Even a momentary short circuit can cause an explosion resulting in injury. Make all electrical connections to the Distribution Cabinet without DC input power applied.

4.2 Mounting the Cabinet

Mount the assembly into a 19" or 23" relay rack.

Use the supplied hardware to secure the assembly to the relay rack. Use a supplied grounding washer at each mounting location. Torque to 70 in-lbs.



NOTE! Install (orient) the ground washers so the teeth dig into the mounting angles for a secure ground connection.



NOTE! Compliance with Telcordia GR-1089-CORE requires that prior to mounting the system to the equipment rack.

- All paint must be removed from the front surface of each equipment rack rail where it mates with a shelf-mounting bracket, so that good metal-to-metal contact can be established between the shelf and rack.
- The shelf-to-rack mating surfaces must be cleaned.
- Electrical anti-oxidizing compound must be applied to the shelf-to-rack mating surfaces.

4.3 Installing Distribution Devices



NOTE! This procedure may have already been performed at the factory.

Install distribution devices in the cabinet in the order described in this procedure.



CAUTION! In a +40 °C ambient, 100 A circuit breakers can be used without a space provided the continuous current in each device does not exceed 64 A. Overcurrent protective devices greater than 100 A shall have an empty mounting position between it and any other overcurrent protective device.

At or above +65 °C, the maximum size overcurrent device used shall be 70 A. Devices rated at 70 A or less shall have an empty mounting position between it and any other overcurrent protective device.

Procedure

1. Open the front door of the Distribution Cabinet. To do so, loosen the two captive fasteners on the door, then pivot the door downward.
2. If installing one or more GMT Fuse Assemblies (Part No. 545333), install starting at the left side of the cabinet, working toward the right. Refer to Figure 4.1 for details. Note that each GMT Fuse Assembly occupies **two** distribution positions.
3. Install the circuit breakers or TPS/TLS-type fuseholders from right to left, starting with the highest capacity and working to the lowest capacity. Refer to Figure 4.2 for details.

4. Record device current ratings on the label provided on the Distribution Cabinet front door.
5. For TPS/TLS fuseholders only, verify that a 0.18 amp alarm fuse is present in each fuseholder, and that a plastic safety cover is installed on this fuse.
6. If one or more optional GMT Fuse Assemblies was installed, for each assembly:
 - Install an appropriately sized GMT-type fuse in each fuse mounting position as required. If dummy fuses are present, first remove the dummy fuse.
 - Verify that a plastic safety cover is installed on each GMT fuse.
 - Verify that dummy fuses are installed in all unused fuse positions.
7. The front door of the Distribution Cabinet will be closed after all wiring connections have been completed.

Figure 4.1 Installing Optional GMT Fuse Assembly, Part No. 545333

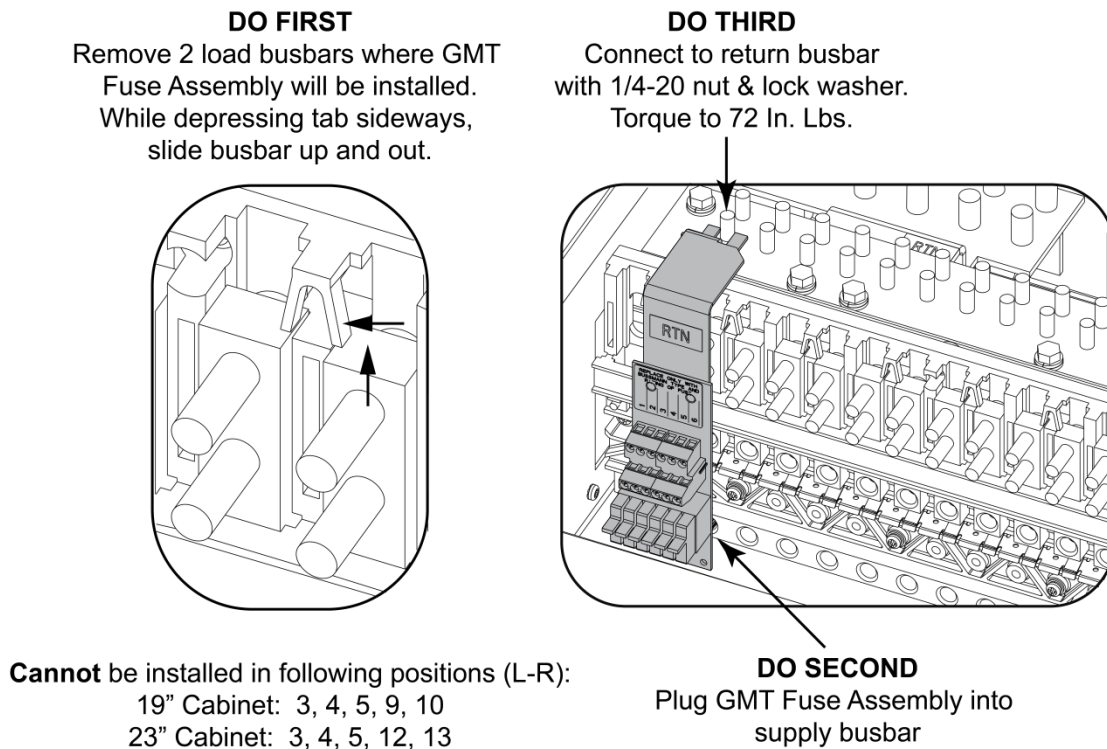
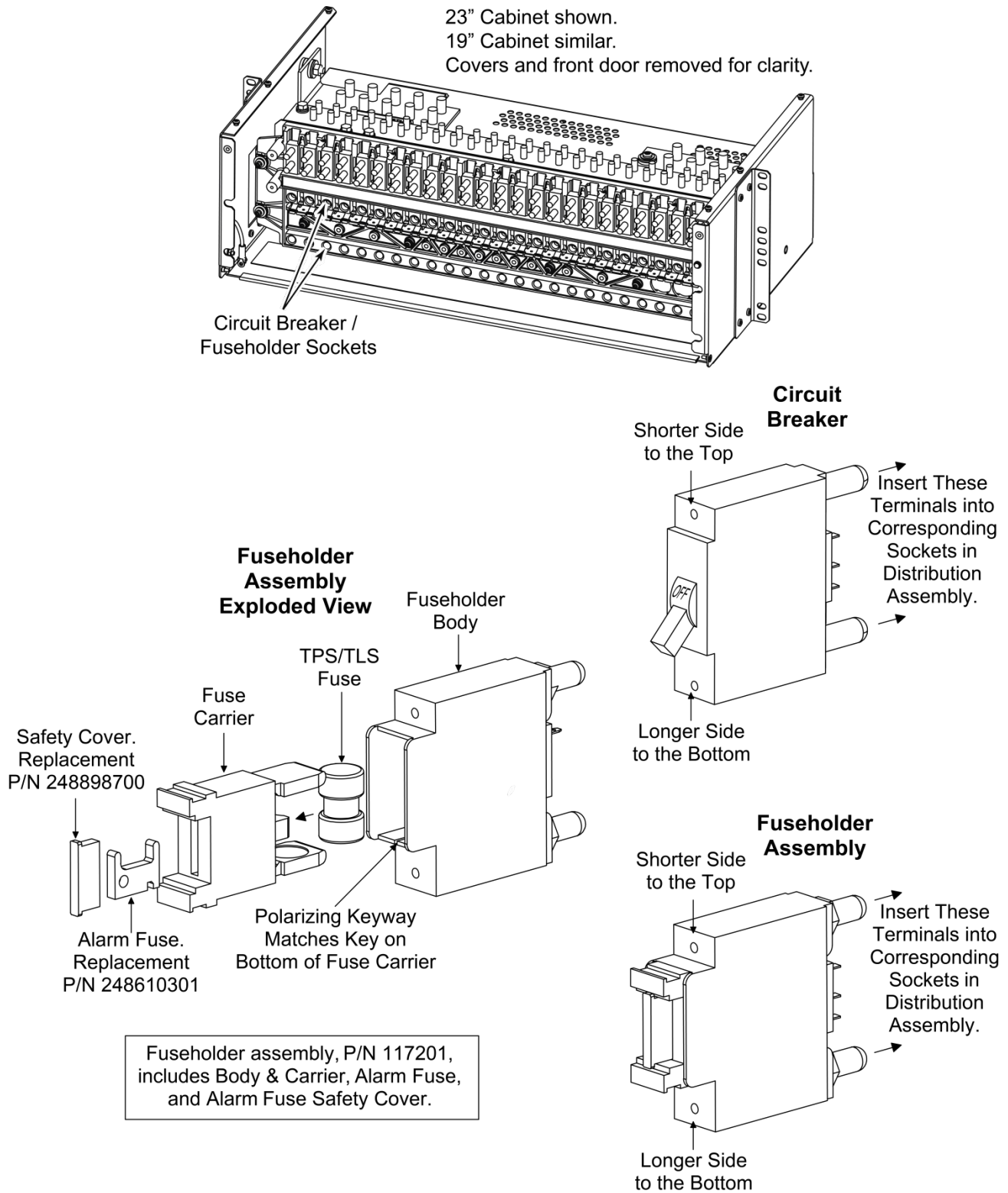

Figure 4.2 Installing Distribution Devices



4.4 Electrical Connections

Wiring Considerations

All wiring and grounding should follow the current edition of the National Electrical Code and applicable local codes.

Equipment Grounding Connection (Frame Ground)

The assembly is grounded to the relay rack by using grounding washers (supplied) with the relay rack mounting hardware, refer to “Mounting the Cabinet” on page 14. Ensure that the relay rack is properly grounded.

Accessing Electrical Connections

Procedure

1. If not already done, open the front door of the Distribution Cabinet. To do so, loosen the two captive fasteners on the door, then pivot the door downward.
2. If furnished, remove the two top covers from the Distribution Cabinet. To do so for each, loosen but do not remove the screws located on the top of the cover. Slide the cover to the front until the screw heads clear the slots in the cover. Then remove the cover. Refer to Figure 4.3 for location.



NOTE! If Cabinet is equipped with the rear feed input busbar kit, refer to Figure 4.5 for Top/Rear Cover removal.

DC Input Connections



DANGER! To avoid injury, it is recommended that DC power be disconnected from the input leads before connecting them to the Distribution Cabinet.



WARNING! Check for correct polarity before making connections.

When NOT Equipped with Optional Rear-Feed Busbars

1. Refer to Figure 4.4. Lug mounting location and identification, as well as recommended torque are shown.
2. -48V: Connect the negative (-) input conductor(s) to the input busbar labeled -48V. Two-hole lugs with 3/8” bolt clearance holes on 1” centers are required. For Spec. No. 548066 and 548067, factory provides lug-mounting hardware. For Spec. No. 561569, customer to provide lug mounting hardware.
3. Return: Connect the positive (+) input conductor(s) to the input busbar labeled RTN. Two-hole lugs with 3/8” bolt clearance holes on 1” centers are required. For Spec. No. 548066 and 548067, factory provides lug-mounting hardware. For Spec. No. 561569, customer to provide lug mounting hardware.

When Equipped with Optional Rear Feed Busbars

1. If not already done, remove the top/rear covers as shown in Figure 4.5.
2. Refer to Figure 4.5. Lug mounting location and identification, as well as recommended torque are shown.
3. -48V: Connect the negative (-) input conductor(s) to the input busbar labeled -48V. Two-hole lugs with 3/8” bolt clearance holes on 1” centers are required. Factory provides lug-mounting hardware.
4. Return: Connect the positive (+) input conductor(s) to the input busbar labeled RTN. Two-hole lugs with 3/8” bolt clearance holes on 1” centers are required. Factory provides lug-mounting hardware.
5. The top/rear covers will be installed after all electrical connections are complete.

Figure 4.3 Top Cover Removal (Without Rear Feed Busbar Kit)

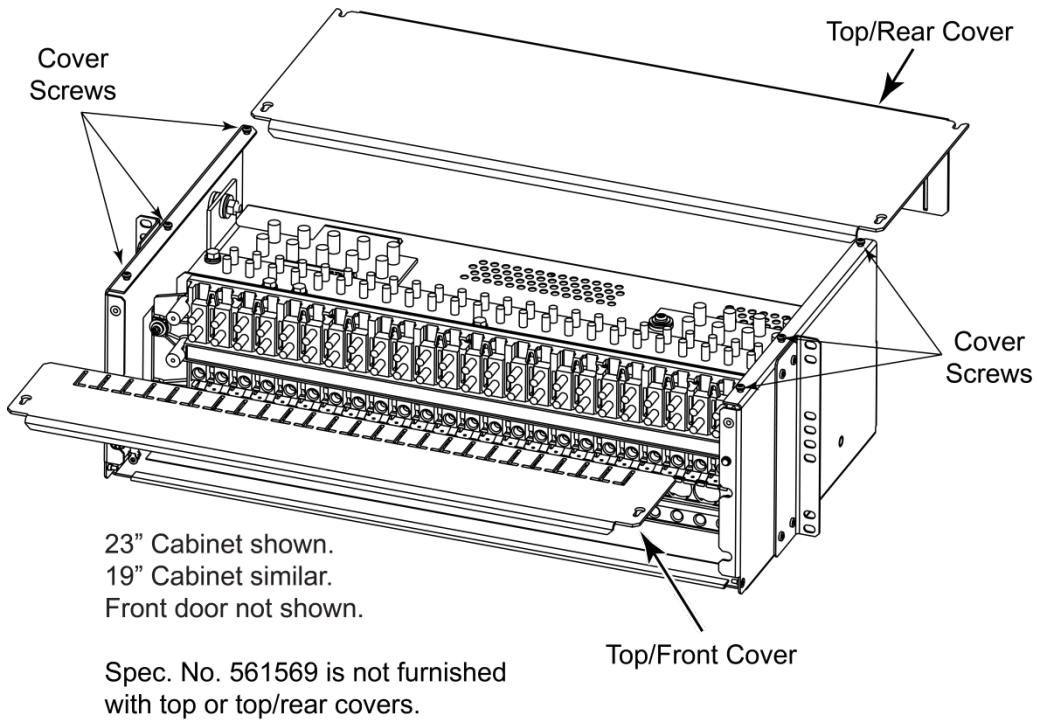

Figure 4.4 DC Input Connections (Without Rear Feed Busbar Kit)

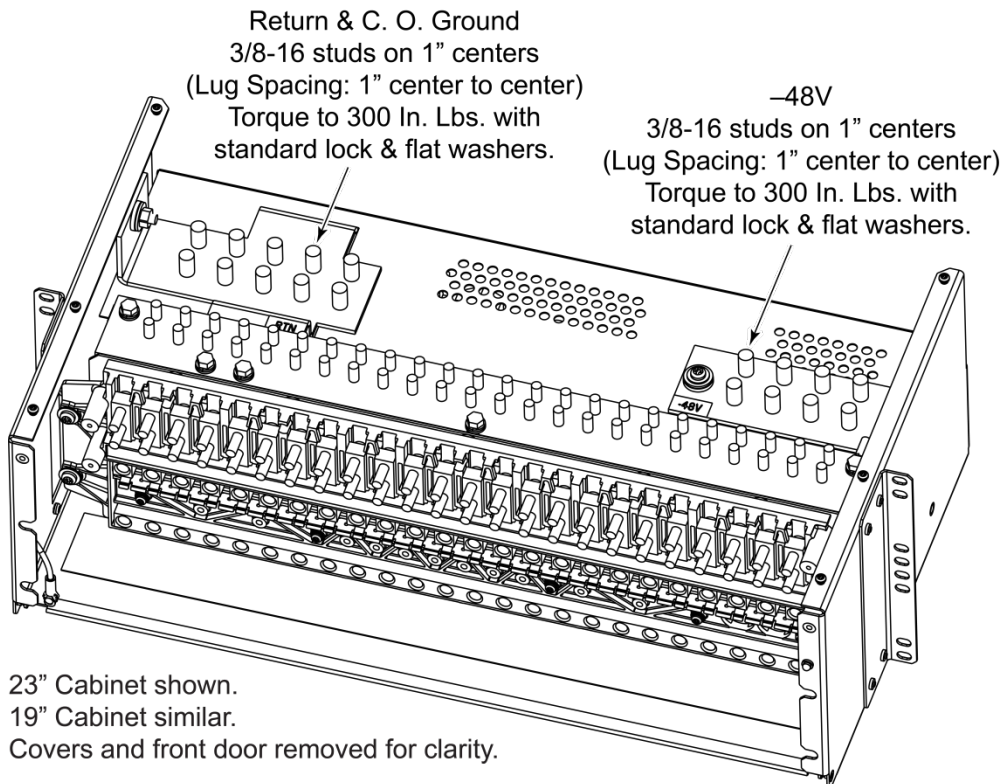
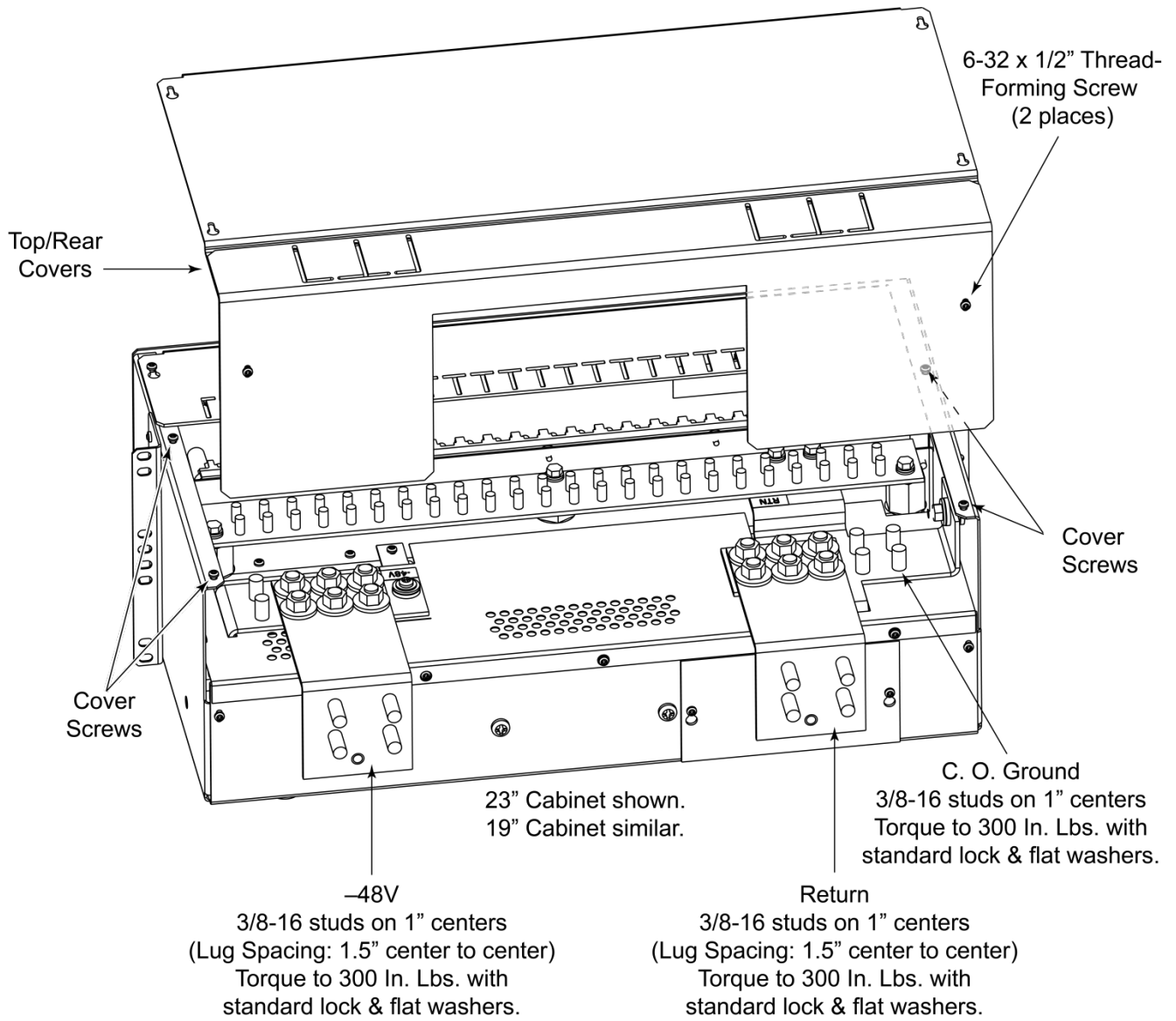

Figure 4.5 DC Input Connections (With Rear Feed Busbar Kit)



-48V DC Load Connections



WARNING! Check for correct polarity before making connections.

Procedure

1. Refer to Figure 4.6 when making distribution Load and Load Return connections. Lug mounting location and identification, as well as recommended torque are shown. Maximum size of wire to be connected to a single position is 2 AWG. Note that right angle lug adapter P/N 545405 is factory furnished and installed on all load distribution positions for Spec. No. 561569, kit P/N 10009822, and kit P/N 10012729.
2. Load: Load conductors can exit the Distribution Cabinet toward the top or the rear. Connect lug-terminated Load conductors to the distribution fuseholder/circuit breaker mounting positions. Two-hole lugs with 1/4-inch bolt clearance holes on 5/8-inch centers are required. Lug mounting hardware must be ordered separately or furnished by the installer.
3. Load Return: Load Return conductors must exit the Distribution Cabinet toward the rear. Connect lug-terminated Load Return conductors to the distribution ground busbar. Two-hole lugs with 1/4-inch bolt clearance holes on 5/8-inch centers are required. Lug mounting hardware must be ordered separately or furnished by the installer.

Figure 4.6 Load Connections

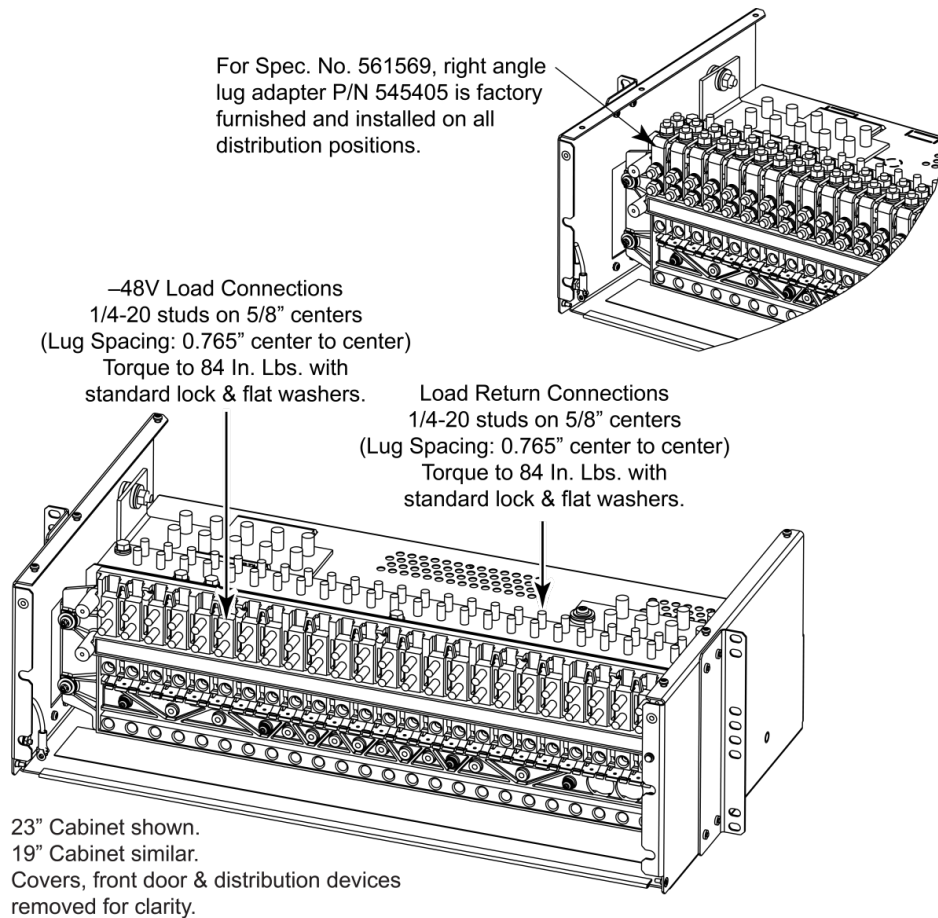

Load Connections to Optional GMT Fuse Assembly

If the Part No. 545333 GMT Fuse Assembly is present, connect load and load return leads to terminal blocks on the assembly.

Observe correct polarity as shown in Figure 4.7 when connecting leads. Tighten screws as specified in the figure.

Figure 4.7 Load Connections to GMT Fuse Assembly, Part No. 545333

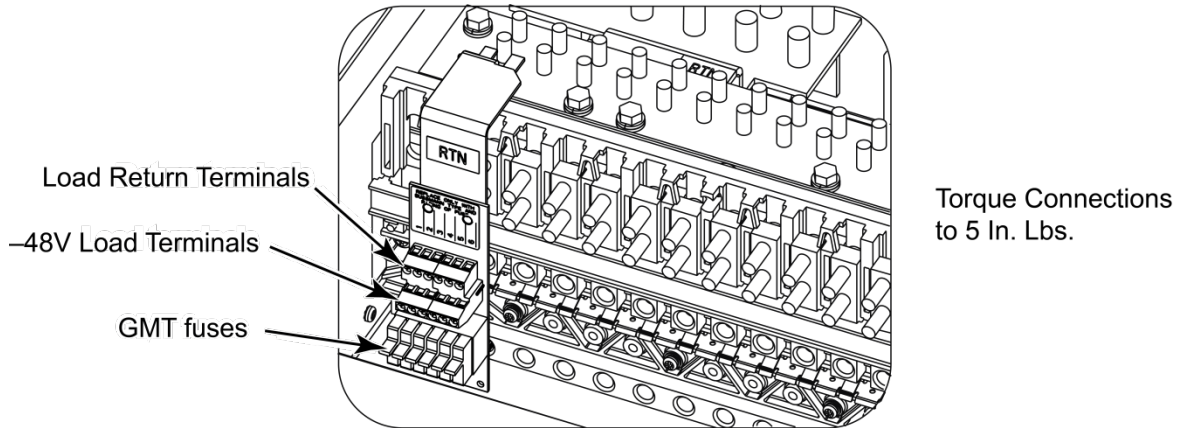

External Circuit Breaker / Fuse Alarm Connections

A yellow 22 AWG lead, un-terminated, is provided for the circuit breaker / fuse alarm connection. If any circuit breaker or fuse opens, resistive battery (-) is provided to this yellow lead. The lead is located inside the cabinet at the right side near the rear.

Shunt Connections

A shunt is provided for monitoring of total load current via customer equipment. The shunt rating is 25mV @ 600A. Make connections to the provided shunt leads. The leads are approximately 12 ft. long, 22 AWG stranded wire in a twisted pair, and un-terminated. The leads are color-coded: red for positive (+) and black for negative (-). The leads are located inside the cabinet at the right side near the rear.

Installing Covers (if furnished)

Procedure

1. Cutouts are provided in the two top covers for passage of wiring from each distribution position. Use wire cutters to remove as required. Remove only the cutouts required for your installation.



NOTE! If the Cabinet is equipped with the rear feed input busbar kit, Load Return wiring should be routed through the large opening in the center of the rear cover.

2. Refer to Figure 4.3 or Figure 4.5. Place the top/rear cover in position while guiding cables into the openings where cutouts were removed. Position the cover so that the mounting screw heads pass through the slots in the cover. Slide the cover towards the rear. Tighten the four screws.
3. Refer to Figure 4.3. Place the top/front cover in position while guiding cables into the openings where cutouts were removed. Position the cover so that the mounting screw heads pass through the slots in the cover. Slide the cover towards the rear. Tighten the two screws.

4.5 Initial Startup

Procedure

1. Ensure that all access covers are in place.
2. Ensure that fuse safety covers are installed on each fuse, as shown in Figure 4.2.
3. Place all circuit breakers in the ON position.
4. Apply input power to the assembly.
5. Verify that the Circuit Breaker / Fuse Alarm indicator located on the front of the cabinet is extinguished. (See Figure 5.1 for location.) Verify that the external circuit breaker / fuse alarm circuit is not active (if connected). If indicator or external alarm is active, refer to the *Troubleshooting and Repair* section.
6. To verify operation of the circuit breaker / fuse alarm circuit:

If Equipped with Distribution Fuses

- a) Remove an alarm fuse from a TPS/TLS fuseholder, and replace with a known open fuse. Verify the circuit breaker / fuse alarm indicator located on the front of the cabinet illuminates and the external circuit breaker / fuse alarm circuit activates (if connected).
- b) Remove the open alarm fuse and install the good fuse. Verify the circuit breaker / fuse alarm indicator located on the front of the cabinet extinguishes and the external circuit breaker / fuse alarm circuit retires (if connected).

If Equipped with Distribution Circuit Breakers



NOTE! The following procedure is to be used only with circuit breakers that provide an alarm indication when manually placed to the OFF (open) position (black handle). Electrical trip alarm circuit breakers (white handle) cannot be easily tested in the field.

- a) Place the handle (if black) of a circuit breaker in the OFF (open) position. Verify the circuit breaker / fuse alarm indicator located on the front of the cabinet illuminates and the external circuit breaker / fuse alarm circuit activates (if connected).
 - b) Place the handle of the circuit breaker in the ON (closed) position. Verify the circuit breaker / fuse alarm indicator located on the front of the cabinet extinguishes and the external circuit breaker / fuse alarm circuit retires (if connected).
7. Close the front door of the Distribution Cabinet, and secure by tightening the two captive fasteners.

5 Operation

5.1 Indicators

Refer to Figure 5.1 for indicator location.

Circuit Breaker / Fuse Alarm: When illuminated (red), a circuit breaker or fuse is open.

Figure 5.1 Indicator Location

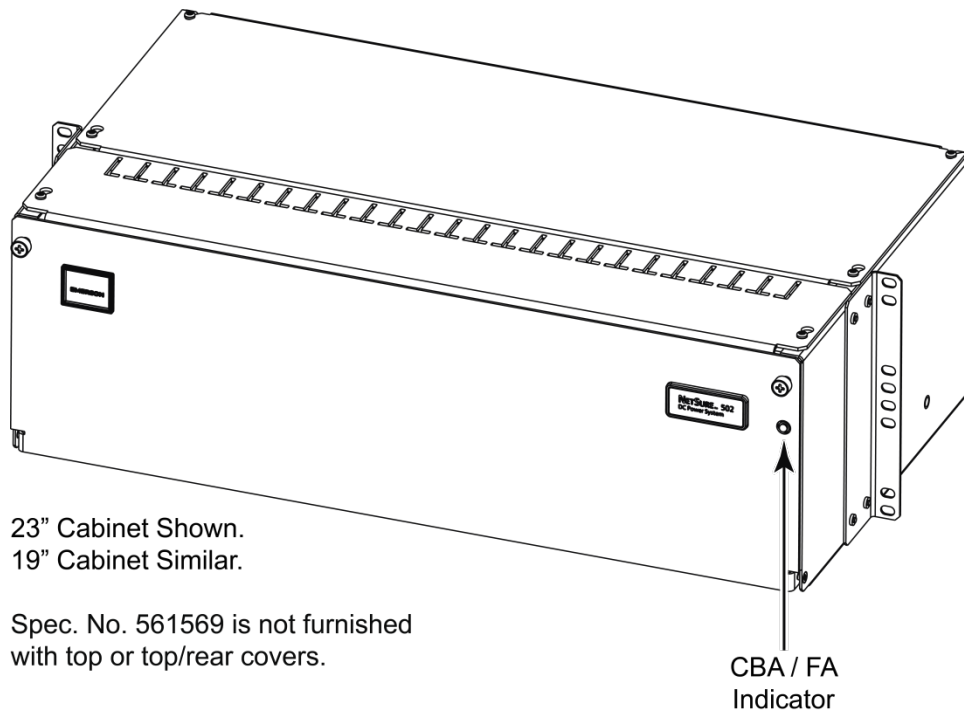

6 Troubleshooting and Repair

Other than the distribution circuit breakers, distribution fuses and alarm fuses, the assembly contains no user-replaceable parts. No attempt should be made to repair the assembly. If repair is required, contact Vertiv Co.

If the local Circuit Breaker/Fuse Alarm indicator illuminates and external circuit breaker/fuse alarm circuits activate (if connected), check for an open circuit breaker or alarm fuse. An open alarm fuse will provide an indicator that is visible through the front of the fuse safety cover. An open alarm fuse indicates that the corresponding distribution fuse has opened. Refer to *TPS/TLS Type Fuse Replacement* or *Circuit Breaker Replacement* in this section for a replacement procedure.



NOTE! Loss of DC input power to the Distribution Cabinet will prohibit the local alarm indicators and external fuse alarm circuits from activating.

6.1 TPS/TLS Type Fuse Replacement

A defective TPS/TLS-type fuse is replaced by removing the fuse carrier from the fuseholder, and replacing the defective fuse.

Procedure



NOTE! Refer to Figure 4.2 as this procedure is performed.

1. Open the front door of the Distribution Cabinet. To do so, loosen the two captive fasteners on the door, then pivot the door downward.
2. Remove the fuse carrier from the mounted fuseholder body by grasping firmly and pulling it straight out.
3. Replace the open fuse with the same type and rating, or equivalent.
4. Replace the alarm fuse located in the front of the fuse carrier. Replace only with a fuse of the same type and rating. Ensure that a plastic safety cover is installed on the alarm fuse.
5. When done, push the fuse carrier back into the fuseholder body. Note that a polarizing key on the bottom of the carrier prevents the carrier from being inserted upside down.
6. Verify no circuit breaker / fuse alarms are active.
7. Close the front door of the Distribution Cabinet, and secure by tightening the two captive fasteners.

6.2 Bullet Nose Type Fuseholder Replacement

Procedure



NOTE! Refer to Figure 4.2 as this procedure is performed.

1. Open the front door of the Distribution Cabinet. To do so, loosen the two captive fasteners on the door, then pivot the door downward.
2. Remove the fuse carrier from the mounted fuseholder body by pulling it straight out.
3. Gently rock the defective fuse holder up and down while pulling firmly outward until the fuse holder is free from the distribution assembly.



WARNING! If the following procedure is not followed, the fuseholder may be damaged.

4. Install the replacement fuseholder. Orient as shown in the figure, with the shorter side of the front surface toward the top and longer side toward the bottom. Insert the terminals on the rear of the fuseholder into their corresponding sockets on the distribution assembly. Push fuseholder in firmly until fully seated.
5. Push the fuse carrier back into the fuseholder body. Note that a polarizing key on the bottom of the carrier prevents the carrier from being inserted upside down.
6. Verify no Fuse Alarms are active.
7. Close the front door of the Distribution Cabinet, and secure by tightening the two captive fasteners.

6.3 Circuit Breaker Replacement

Procedure



NOTE! Refer to Figure 4.2 as this procedure is performed.

1. Open the front door of the Distribution Cabinet. To do so, loosen the two captive fasteners on the door, then pivot the door downward.
2. Operate the defective circuit breaker to the OFF position.
3. Gently rock the defective circuit breaker up and down while firmly pulling outward until the breaker is free.
4. Ensure that the replacement circuit breaker is in the OFF position, and is of the correct rating.



CAUTION! In the next step, the circuit breaker alarm will operate incorrectly if the circuit breaker is installed upside down.

5. Install the replacement circuit breaker. Orient as shown in the figure, with the shorter side of the front surface toward the top and longer side toward the bottom. Insert the terminals on the rear of the circuit breaker into their corresponding sockets on the distribution assembly. Push circuit breaker in firmly until fully seated in the distribution assembly.
6. Operate the replacement circuit breaker to the ON position.
7. Verify no circuit breaker / fuse alarms are active.
8. Close the front door of the Distribution Cabinet, and secure by tightening the two captive fasteners.

This page intentionally left blank.

Connect with Vertiv on Social Media



<https://www.facebook.com/vertiv/>



<https://www.instagram.com/vertiv/>



<https://www.linkedin.com/company/vertiv/>



<https://www.twitter.com/vertiv/>



Vertiv.com | Vertiv Headquarters, 1050 Dearborn Drive, Columbus, OH, 43085, USA

© 2020 Vertiv Group Corp. All rights reserved. Vertiv™ and the Vertiv logo are trademarks or registered trademarks of Vertiv Group Corp. All other names and logos referred to are trade names, trademarks or registered trademarks of their respective owners. While every precaution has been taken to ensure accuracy and completeness here, Vertiv Group Corp. assumes no responsibility, and disclaims all liability, for damages resulting from use of this information or for any errors or omissions. Specifications, rebates and other promotional offers are subject to change at Vertiv's sole discretion upon notice.

UM548066_REVK