



HOT AND COOKING



**Built-in Hotplate, Ovens, Stoves, Minigrills, Hotplate-Sink
Combos for Recreational Vehicles and Marine.**

Installation, use and service manual

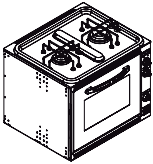

**CU311 - CU333 -
CU335 - CU311M -
CU333M - CU335M**

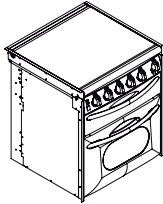

CU401 - CU401PE

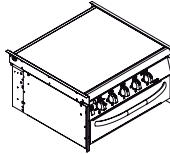

CU402 - CU402PE

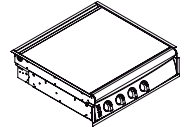

CU403 - CU403PE

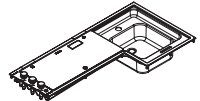

MO9503 - MO9523

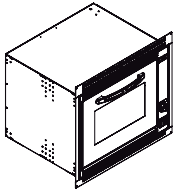

FO311



**PI8002 - PI8022 -
PI8003 - PI8023**

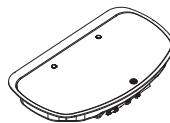

**PI8403 - PI8403GL -
PI8423 - PI8423GL -
PI8443 - PI8463**

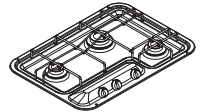

PI0913 - PI0913A

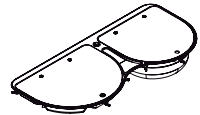

MO8103 - MO8123

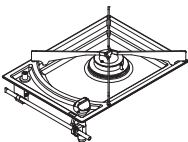

**PI8621A - PI8621R -
PI8621S**

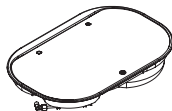

**MO8302 -
MO8322 - MO8303
- MO8323**

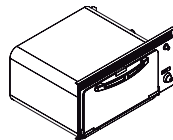

VN555

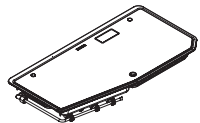

PI7903 - PI7923

© 2021 Dometic Group. The visual appearance of the contents of this manual is protected by copyright and design law. The underlying technical design and the products contained herein may be protected by design, patent or be patent pending. The trademarks mentioned in this manual belong to Dometic Sweden AB.

All rights are reserved.

Please read these instructions carefully and follow all instructions, guidelines, and warnings included in this product manual in order to ensure that you install, use, and maintain the product properly at all times. These instructions **MUST** stay with this product.

By using the product, you hereby confirm that you have read all instructions, guidelines, and warnings carefully and that you understand and agree to abide by the terms and conditions as set forth herein. You agree to use this product only for the intended purpose and application and in accordance with the instructions, guidelines, and warnings as set forth in this product manual as well as in accordance with all applicable laws and regulations. A failure to read and follow the instructions and warnings set forth herein may result in an injury to yourself and others, damage to your product or damage to other property in the vicinity. This product manual, including the instructions, guidelines, and warnings, and related documentation, may be subject to changes and updates. For up-to-date product information, please visit www.dometic.com.

CONTENTS

1.	GENERAL INFORMATION.....	4
1.1	Symbols used in this manual	4
1.2	Using and keeping the manual	4
2.	WARNINGS.....	5
3.	INTENDED USE.....	5
4.	USE.....	6
4.1	Precautions	6
4.2	Control panel	7
4.3	Hotplate	8
4.3.1	Selecting the burner	8
4.3.2	Electronic ignition hotplate (depending on model).....	8
4.3.3	Manual ignition hotplate.....	8
4.3.4	Hotplate flame regulation	9
4.4	Oven	9
4.4.1	Electronic ignition oven.....	9
4.4.2	Manual ignition oven	9
4.4.3	Oven flame regulation with thermostat.....	9
4.5	Grill.....	10
4.5.1	Electronic ignition grill	10
4.5.2	Manual ignition grill	10
4.5.3	Flame regulation grill	11
4.6	Electric hotplate (depending on model)	11
4.7	Spit (depending on model)	11
4.8	Turntable (depending on model).....	11
4.9	Cleaning.....	11
4.10	Abnormal Operation	12
5.	INSTALLATION.....	12
5.1	Dimensions of the appliance.....	12
5.2	Fitting cavity.....	13
5.3	Gas connection	13

5.4	Electric connection	15
5.5	Fixture	16
5.6	Testing (before leaving).....	16
5.6.1	Test point.....	17
5.7	Duplicate data plate	17
6.	SERVICING.....	18
7.	WARRANTY.....	21
	FIGURES AND TECHNICAL DRAWINGS	22
	WHO TO CONTACT	40

1. GENERAL INFORMATION

1.1 Symbols used in this manual

Below are shown the various symbols used in the manual to highlight particularly important information. The safety symbols draw attention to potential hazards for personal safety.

Absolutely respect all safety messages by following these symbols.



WARNING

Risk of injury or death.



CAUTION

To avoid possible injuries and/or malfunctions.

1.2 Using and keeping the manual



WARNING

Always read the instructions provided in full before installing and using this appliance.

The aim of this manual is to supply all the information necessary to ensure that, as well as being used correctly, the appliance can be managed in the safest and most autonomous way possible.

Keep this manual and all the attached documentation in good condition, legible and complete in all its parts; it is forbidden to remove, rewrite or modify the pages of the manual and their content in any way.

Keep the documentation near the appliance, in an accessible place known to all users.

The manual must always accompany the appliance even in the event of sale and must therefore be handed over to the new user.

2. WARNINGS

Do not use or store flammable materials in the appliance storage drawer or near this appliance.

Do not spray aerosols in the vicinity of this appliance while it is in operation.

Do not modify this appliance.

Where this appliance is installed in marine craft or in caravans, it shall NOT be used as a space heater.

This appliance shall be installed only by authorised persons and in accordance with the manufacturer's installation instructions, local gas fitting regulations, municipal building codes, electrical wiring regulations, AS/NZS5601.2.2013 - Gas Installations and any other statutory regulations.

This appliance must be used only in a well ventilated environment. Do not obstruct the flow of combustion and ventilation air.

This appliance is designed and manufactured for cooking food only. Any other use is considered improper and incorrect creating hazardous conditions. The manufacturer declines all responsibility for damage to things or injuries to persons caused by incorrect installation and / or incorrect and improper use.

If the appliance is to be left unused for any length of time, it is recommended that the gas supply be turned off at the cylinder or main supply valve feeding the appliance.

3. INTENDED USE

This product is only suitable for the intended purpose and application in accordance with this instruction. This manual provides information that is necessary for proper installation and/or operation of the product. Poor installation and/or improper operating or maintenance will result in unsatisfactory performance and a possible failure.

All appliances except the CU..., FO... and VN555 models are suitable for use outdoors. If the appliance is stowable ensure that it complies with all requirements for stowed appliances as found in AS/NZS 5601.2.

The manufacturer accepts no liability for any injury or damage to the product resulting from:

- Incorrect assembly or connection, including excess voltage
- Incorrect maintenance or use of spare parts other than original spare parts provided by the manufacturer
- Alterations to the product without express permission from the manufacturer
- Use for purposes other than those described in this manual

Dometic reserves the right to change product appearance and product specifications.

4. USE

4.1 Precautions



WARNING

WARNING

This appliance must not be used by persons (including children) who suffer from psychical and motor related disorders or who are not familiar with or who have no experience with the appliance unless under supervision or are being instructed on how to use the appliance by the person responsible for their safety. Children must always be supervised to prevent them from playing with the appliance.



WARNING

WARNING

The use of gas appliances generates heat and moisture in the immediate area. Always ensure a good ventilation in the cooking area: keep all air vents open for natural ventilation or install an extractor fan (cookerhood).



WARNING

WARNING

An intense and prolonged use of the appliance may require additional ventilation, for example opening a window, or increasing the power of any mechanical extraction system.



WARNING

WARNING

Do not operate appliance during rain unless it has protection such as an awning. Always ensure there is sufficient ventilation available when operating the appliance.



WARNING

This warning is affixed in a visible location on the hotplate glass lid. Glass hotplate lids may shatter when heated. Always raise the lid before igniting a burner/s (hotplate, oven and grill) and turn off all burners (hotplate, oven and grill) and let them cool down before lowering the hotplate glass lid.



WARNING

WARNING

If appliance is installed outdoors and is stowable it shall be stowed away when no longer in use to protect it from damage. Wait until appliance has cooled before stowing.



CAUTION

CAUTION

This appliance must only be used by responsible adults. During use and immediately after use the burner and other accessible parts may be hot; do not touch these parts and always keep children at a safe distance. After using the appliance ensure the knob/knobs are off.

After use always shut off the gas supply at the main gas tap.



CAUTION

CAUTION

Before cooking with the oven and grill for the first time turn on the oven or grill at high flame and leave the oven on for at least 30 minutes and the grill for 15-20 minutes.

Before opening the glass cover of the hotplate, remove any liquids that may have spilled.

NOTE: To minimize corrosion and prolong the life of your appliance ensure that you clean the appliance with a damp cloth and warm soapy water after it has been operated in areas close to salt water.

NOTE: High winds may negatively impact performance.

4.2 Control panel

The following symbols identify which knob corresponds to which burner.

NOTE: Different models could have similar knobs and symbols.



This symbol is positioned near the burner knobs on the hotplate.
The black dot indicates the position of the burner on the hotplate.



This symbol is positioned near the oven burner knob.



This symbol is positioned near the grill burner knob.

The following symbols are for burner flame regulation and correspond to the position of the knob.

NOTE: Different models could have similar knobs and symbols.



Gas off



High flame



Low flame



Electric hotplate off

1 - 2 - 3 - 4 - 5 - 6

Oven and/or electric hotplate temperature



Grill

OTHER SYMBOLS



Electronic ignition pushbutton



CAUTION

This symbol is affixed in a clearly visible position near the oven control knob for all models fitted with electronic ignition which is activated by maintaining the control knob pressed.



Light switch



Spit switch



Turntable switch

In CU4... models it is also present as a turntable and light.

4.3 Hotplate

4.3.1 Selecting the burner



WARNING

WARNING

The flame must never extend beyond the edge of the pan. Centre the pan over the burner ensuring stability on the pan support.

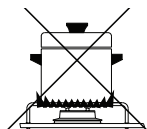
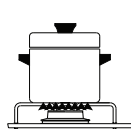

Burner	Pan diameter	
	Min	Max
Auxiliary Ø 47 mm	6 cm	16 cm
Semi-rapid Ø 62 mm	16 cm	22 cm
Rapid Ø 77 mm	16 cm	22 cm

4.3.2 Electronic ignition hotplate (depending on model)



WARNING

WARNING

Make sure there are no pans or any other objects on the burners when igniting.

To ignite the burner, gently push in and turn the control knob to position HIGH FLAME and, keeping the knob pushed in, at the same time press the electronic ignition pushbutton. Once the burner is lit, keep the knob pushed in for a few seconds to ensure the flame remains lit.



CAUTION

CAUTION

If the burner does not ignite immediately repeat ignition after having followed each step below:

- Turn the knob to "Low flame"
- Proceed with manual ignition
- Check there is sufficient gas in the gas bottle.

If the appliance still does not ignite shut off the gas supply at the main gas tap and contact your local dealer.

4.3.3 Manual ignition hotplate

Manual ignition when the appliance is not fitted with the electronic ignition feature or in the event of failure in the electronic ignition.



WARNING

WARNING

Make sure there are no pans or any other objects on the burners when igniting.

To ignite the burner, gently push in and turn the control knob to position HIGH FLAME and, keeping the knob pushed in, at the same time light the burner with a match or gas lighter. Once the burner is lit, keep the knob pushed in for a few seconds to ensure the flame remains lit.



CAUTION

CAUTION

If the burner does not ignite immediately, check there is sufficient gas in the gas bottle.

If the appliance still does not ignite, shut off the gas supply at the main gas tap and contact your local dealer.

4.3.4 Hotplate flame regulation

To regulate the flame turn the knob to the desired cooking flame.

4.4 Oven



CAUTION

The oven burner must be ignited only with the oven door fully open.



WARNING

The wire shelf, drip tray and oven dish when in the oven must be positioned so as to avoid coming into contact with the flames.

If the burner flame goes out accidentally, turn off the gas knob and wait one minute before re-igniting.

4.4.1 Electronic ignition oven

To ignite the burner, push in and turn the control knob to a position from 1 to 6 and, keeping the knob pushed in, at the same time press the electronic ignition pushbutton (for models that have  affixed to the oven door the electronic ignition button is not visible and is activated by pressing the gas knob down). Once the burner is lit, keep the knob pushed in for a few seconds to ensure the flame remains lit.



CAUTION

If the burner does not ignite immediately, repeat ignition after having followed each step below:

- proceed with manual ignition
- check there is sufficient gas in the gas bottle.

If the appliance still does not ignite, shut off the gas supply at the main gas tap and contact your local dealer.

4.4.2 Manual ignition oven

Manual ignition when the appliance is not fitted with the electronic ignition feature or in the event of failure in the electronic ignition.

To ignite the burner, gently push in and turn the control knob to a position from 1 to 6 and, keeping the knob pushed in, at the same time light the burner with a match or gas lighter. Once the burner is lit, keep the knob pushed in for a few seconds to ensure the flame remains lit.



CAUTION

If the burner does not ignite immediately, check there is sufficient gas in the gas bottle.

If the appliance still does not ignite, shut off the gas supply at the main gas tap and contact your local dealer.

4.4.3 Oven flame regulation with thermostat

Positions	1	2	3	4	5	6
Temperature	130 °C	160 °C	180 °C	200 °C	220 °C	240 °C

When the oven burner is ignited the flame remains at high flame in all knob positions. When the oven reaches the set temperature the flame automatically goes down to low flame.

4.5 Grill



CAUTION

The grill burner must be ignited only with the door fully open.



CAUTION

WARNING

If the burner does not ignite immediately, release the knob, wait for at least 10 seconds and ignite again.

As accessible parts may be very hot when using the grill, keep children at a safe distance from grill.

When using the grill the door must be kept open and with the heat guard fully extracted (FIG. 1 – PG. 19).

Never use the grill for more than 25 minutes. The grill cannot be used as an oven.

If the burner flame goes out accidentally, turn off the gas knob and wait one minute before re-igniting.

4.5.1 Electronic ignition grill



WARNING

WARNING

Do not ignite the grill burner with the door closed.

To ignite the burner, gently push in and turn the control knob to position GRILL or HIGH FLAME and, keeping the knob pushed in, at the same time press the electronic ignition button (for models with the  symbol affixed to the door, the ignition button is not visible and is activated by pressing the knob down). Once the burner is lit, keep the knob pushed in for a few seconds to ensure the flame remains lit.



CAUTION

CAUTION

If the burner does not ignite immediately, repeat ignition after having followed each step below:

- proceed with manual ignition
- check there is sufficient gas in the gas bottle.

If the appliance still does not ignite, shut off the gas supply at the main gas tap and contact your local dealer.

4.5.2 Manual ignition grill

Manual ignition when the appliance is not fitted with the electronic ignition feature or in the event of failure in the electronic ignition.

To ignite the burner, gently push in and turn the control knob to position GRILL or HIGH FLAME and, keeping the knob pushed in, at the same time light the burner with a match or gas lighter. Once the burner is lit, keep the knob pushed in for a few seconds to ensure the flame remains lit.



CAUTION

CAUTION

If the burner does not ignite immediately, check there is sufficient gas in the gas bottle.

If the appliance still does not ignite, shut off the gas supply at the main gas tap and contact your local dealer.

4.5.3 Flame regulation grill

For models CU311 - CU311M - CU333 - CU333M - CU335 - CU335M - FO311:

the grill is to be used only at its maximum capacity.

For all other models:

to regulate flame, turn the knob to the desired cooking flame.

4.6 Electric hotplate (depending on model)



CAUTION

CAUTION

Before turning on the electric hotplate (or if the hotplate has remained unused for a long time) it is necessary to eliminate any moisture by turning on the hotplate and leaving it on for 30 minutes with the corresponding knob in position 1.

Use pans with flat bottoms and with diameters no less than the diameter of the hotplate.

Dry the bottom of the pan before placing it on top of the hotplate.

When using the hotplate do not leave the appliance unattended and make sure children are nowhere near the appliance.

The electric hotplate is controlled by a 7-position knob: position off is 0 (zero) whereas positions 1 to 6 are for regulating the hotplate. Positions 1 to 6 correspond to an increase in temperature of the hotplate. There is a red LED positioned next to the knob which lights up when the hotplate is on.

4.7 Spit (depending on model)

Ignite the oven as described in the chapter 3.4 Oven. Turn the gas knob to the required position. Insert the drip tray with the spit already installed as illustrated in FIG. 2 - PG. 19. Press the spit button to turn on the spit motor.

4.8 Turntable (depending on model)

Ignite the oven burner as indicated in chapter 3.4 Oven. Insert the turntable as indicated in FIG. 3 - PG. 19. Press the switch to operate the turntable motor.

4.9 Cleaning

No regular maintenance is required except cleaning.



WARNING

WARNING

Some cooking operations generate a considerable amount of grease. This, combined with spillage, can become a hazard if allowed to accumulate on the appliance through lack of cleaning.



CAUTION

CAUTION

Keep the appliance clean and in good working condition. To clean below the hotplate burners, remove the burner cap screws using a suitable screwdriver. Once the screws are removed, the burner cap and burner head can be removed to provide access below the burner. Once cleaned, ensure the burner head and burner cap are refitted. It is recommended to have it serviced annually by authorized personnel.

**WARNING**

Before cleaning the appliance always turn it off and disconnect from power supply and wait until it has cooled down.

**WARNING**

Do not use alcohol or solvents to clean any part of appliance.

**WARNING**

Never use abrasive and / or coarse cleaning materials or metal brushes to clean the glass oven door as these materials scratch the glass surface with the risk of shattering the glass.

**WARNING**

Never use steam cleaners to clean the appliance.

**CAUTION**

Hot surfaces may be damaged on contact with cold water or with a wet cloth. Do not use abrasive, corrosive or chlorine-based products, pot scourers or steel wool. Do not leave acid or alkaline substances (vinegar, salt, lemon juice, etc.) on the surfaces of the appliance. Glasses, stainless steel surfaces and enamelled parts must be washed with water and neutral soap or detergent, rinsed and dried. Use clean sponges and cloths.

**CAUTION**

Do not leave heavy spillover to bake on, as this will make cleaning more difficult.

**CAUTION**

The trivet (pan support) can be removed by carefully pulling the extended pins evenly out of the plastic locaters in the hotplate. When replacing the trivet, ensure that the plastic guides are not damaged.

4.10 Abnormal Operation

Gas valves, which are difficult to turn are considered to be abnormal operation and may require servicing. In case the appliance fails to operate correctly, contact the authorised service provider in your area.

5. INSTALLATION

5.1 Dimensions of the appliance

The overall dimensions are illustrated in FIG. 5 - PG. 21 with the cavity diagrams.

The overall dimensions include the trivet (pan support), control knobs, handles and gas connection.

5.2 Fitting cavity



WARNING

The appliance must be fitted at an appropriate and safe distance from flammable materials.



WARNING – For CU3... and FO311 models

The cavity that the appliance is built into must be completely sealed off. It is important that the inside panels of the cavity are completely sealed and do not communicate with adjoining cavities or the outside. The openings in the cavity that allow access to the gas and electric connections should be sealed with rubber or foam.

The gas connection (1/4 BSPT female) is located at the rear for models CU..., FO... and for model VN555, whereas it is on the bottom for models PL... and MO...

The electric connection is located at the rear for models CU..., FO... and for model VN555, whereas it is on the bottom for models PL... and MO... (consult chapter 4.4 Electric connection to see whether the appliance needs this connection).

Minimum allowable distances from walls (FIG. 4 - PG. 20)

200 mm	From the external edge of the burner head nearest to a side and / or back wall.
500 mm	Between the top part of the burners and cabinets and / or shelves fitted above the hotplate (for all models except CU401).
550 mm	Between the top part of the burners and cabinets and / or shelves fitted above the hotplate (for CU401 model).
100 mm	From the sides of the appliance and vertical walls.
170 mm	From the top side to the cabinets and / or shelves fitted above the appliance.

Dimensions of fitting cavity

Cut out a hole in the cabinet as illustrated in FIG. 5 - PG. 21 size will depend on appliance model.

The cabinet must be appropriately constructed and aligned horizontally with the worktop and with the unit.

The cabinet aperture must be perfectly squared and aligned. If there are apertures for cabinet ventilation, prevent flammable materials from entering these.

5.3 Gas connection



WARNING

This appliance shall be installed only by authorised persons and in accordance with the manufacturer's installation instructions, local gas fitting regulations, municipal building codes, electrical wiring regulations, AS/NZS5601.2.2013 - Gas Installations and any other statutory regulations.



WARNING

This appliance is not connected to a flue terminal which discharges the product of combustion to the outside. Any enclosed space in which the appliance is installed must therefore be provided with permanent ventilation in accordance with relevant federal and state regulations in force, and the requirements of gas installations with particular attention being paid to the matter of room ventilation.

**WARNING**

The appliance is not suitable for connection with a hose assembly.

**WARNING**

A manual shut-off valve shall be provided on the inlet connection of the appliance. The valve shall be accessible for operation and firmly fixed.

Below are the gas characteristics for which the appliance is set (given also on the appliance data plate). A pressure reducer suitable for the type of gas used must be connected between the gas cylinder and the appliance:

GAS	PRESSURE	OUTPUT OF THE REGULATOR
UNIVERSAL LPG	2,75 kPa	2,5kg/h

NOMINAL GAS CONSUMPTION

Model	AUXILIARY Ø 47 mm		SEMI-RAPID Ø 62 mm		RAPID Ø 77 mm		Grill		Oven		TOTAL NOMINAL GAS CONSUMPTION Mj/h
	Nº	Mj/h	Nº	Mj/h	Nº	Mj/h	Nº	Mj/h	Nº	Mj/h	
CU311	2	3.8	2	5.9			1	5.2	1	3.8	24.6
CU311M	2	3.8	2	5.9			1	5.2	1	3.8	24.6
CU333	1	3.8	1	5.9			1	5.2	1	3.8	14.9
CU333M	1	3.8	1	5.9			1	5.2	1	3.8	14.9
CU335	1	3.8	2	5.9			1	5.2	1	3.8	20.8
CU335M	1	3.8	2	5.9			1	5.2	1	3.8	20.8
CU401	1	3.8	3	5.9			1	5.2	1	3.8	30.5
CU401PE	1	3.8	2	5.9			1	5.2	1	3.8	24.6
CU402	1	3.8	3	5.9			1	5.2			26.7
CU402PE	1	3.8	2	5.9			1	5.2			20.8
CU403	1	3.8	3	5.9							21.5
CU403PE	1	3.8	2	5.9							15.6
FO311							1	5.2	1	3.8	5.2
MO8103	2	3.8	1	5.9							13.5
MO8123	2	3.8	1	5.9							13.5
MO8302	1	3.8	1	5.9							9.7
MO8322	1	3.8	1	5.9							9.7
MO8303	2	3.8	1	5.9							13.5
MO8323	2	3.8	1	5.9							13.5
MO9503	1	3.8	1	5.9	1	7.2					16.9
MO9523	1	3.8	1	5.9	1	7.2					16.9
PI0913	2	3.8	1	5.9							13.5
PI0913A	2	3.8	1	5.9							13.5

NOMINAL GAS CONSUMPTION

Model	AUXILIARY Ø 47 mm		SEMI-RAPID Ø 62 mm		RAPID Ø 77 mm		Grill		Oven		TOTAL NOMINAL GAS CONSUMPTION MJ/h
	Nº	MJ/h	Nº	MJ/h	Nº	MJ/h	Nº	MJ/h	Nº	MJ/h	
PI7903	1	3.8	1	5.9	1	7.2					16.9
PI7923	1	3.8	1	5.9	1	7.2					16.9
PI8002	1	3.8	1	5.9							9.7
PI8022	1	3.8	1	5.9							9.7
PI8003	1	3.8	2	5.9							15.6
PI8023	1	3.8	2	5.9							15.6
PI8403	1	3.8	2	5.9							15.6
PI8403GL	1	3.8	2	5.9							15.6
PI8423	1	3.8	2	5.9							15.6
PI8423GL	1	3.8	2	5.9							15.6
PI8443	1	3.8	2	5.9							15.6
PI8463	1	3.8	2	5.9							15.6
PI8621A	1	3.8									3.8
PI8621R					1	7.2					7.2
PI8621S			1	5.9							5.9
VN555							1	5.2			5.2

BURNER	INJECTOR ORIFICE (mm)	STAMPED Nº
AUXILIARY (Ø 47mm)	0.57	57
SEMI-RAPID (Ø 62mm)	0.72	72
RAPID (Ø 77mm)	0.80	80
GRILL	0.67	67
OVEN	0.57	57

The connection of the gas pipe to the appliance (1/4 BSPT female) must be made with a rigid metal pipe. The pipe work and fittings shall be free from defects and of an approved type.

Once installed, the installation must be checked for leaks by means of an approved testing method.

Do not use a solution of soap and water.

**WARNING**

Never use a naked flame to check for gas leaks.

WARNING

5.4 Electric connection

Low voltage 12 V ---

This chapter concerns only models marked 12 V --- on the appliance data plate.



CAUTION

CAUTION

This appliance must be connected to a 12 V $\overline{\text{---}}$ source. The circuit must be protected by a fuse of no more than 3 Ampere.

Ensure that the polarity of the connection is correct!



WARNING

WARNING

Absolutely do not connect the appliance to the mains voltage (230 V \sim), this would destroy the components and cause a hazard for the user.

To connect the appliance use a 1.5 mm² double red and black wire and wire to the terminal junction box located at the rear of the appliance with the wording "+12 V $\overline{\text{---}}$ - ". The red terminal is the positive pole and the black terminal is the negative pole.

High voltage 230-240 V \sim

This chapter refers only to the models listed in the table below.

Model	Nominal voltage	Nominal power
CU401PE - CU402PE - CU403PE	230-240V \sim	800 W

In these models there is an electric plate in the hotplate.



WARNING

WARNING

When connecting direct to the mains supply, it is necessary to install a circuit breaker which allows for disconnecting and isolating the appliance from the mains in the event of overvoltage III conforming to installation regulations.

The supply cord must be positioned in such a way that it never reaches a temperature of 75 °C above ambient in any point.

The plug must be easy to access after installation.

Always disconnect electrical power before working on or servicing the appliance.

For connecting to the mains power supply use a socket.

If the supply cord (H05RR-F 3x0,75mm²) is damaged, it must be replaced by the manufacturer or its service agent or a similarly qualified person in order to avoid a hazard.

5.5 Fixture



CAUTION

CAUTION

This appliance is to be fixed and secured to the cabinet as described in FIG. 6 – PG. 28.

5.6 Testing (before leaving)

Ignite all burners both individually and concurrently to ensure correct operation of gas valves, burners and ignition. Turn gas taps to low flame position and observe stability of the flame for each burner individually and concurrently. Ensure correct operation of the flame failure protection.

Depending on the type of gas used, the appearance of the flame is as follows:

Propane: flame with blue centre and well-defined contour.

Butane: flame with light yellow tips when igniting the burner, gradually intensifying as the burner heats.

CAUTION

In case the appliance fails to operate correctly after all checks have been carried out, shut off the gas supply at the main gas tap and refer to the authorized service provider in your area.

When satisfied with the appliance, please instruct the user on the correct method of operation.

5.6.1 Test point

For models PI... MO... CU...

The test point is supplied loose with the appliance (see picture in FIG. 7 - PG. 34). Remove one burner head, the injector and screw in test point fitting. The pressure is measured with the relevant burner gas valve on high flame and with an inlet pressure of 2.75 kPa.

For models FO...

The test point is fitted on the main gas pipe. Remove the front plastic plaque (see picture in FIG. 8 - PG. 34) and remove the screw. The pressure is measured with an inlet pressure of 2.75 kPa.

For models VN555

The test point is fitted on the main gas pipe. Remove the screw. The pressure is measured with an inlet pressure of 2.75 kPa.

5.7 Duplicate data plate

After installation, the data plate may be consulted by opening the door of the oven or of the grill compartments, or on the back of the instructions manual.

The date of manufacture can be deduced from the serial number: the 2nd and the 3rd figure indicate the year, the 4th and the 5th figure the week. See the example below.



6. SERVICING



WARNING

The servicing shall be carried out only by authorized personnel.



WARNING

Do not modify this appliance.



WARNING

Before any servicing intervention shut off gas supply, disconnect all the electrical power supplies and remove the appliance.

Hotplate: burners, injectors, thermocouples and ceramic igniters

1. Remove trivet (pan support) by pulling up from hotplate.
2. Remove screws from appropriate burner head disk. Remove head disk.
3. Remove burner by lifting straight up, taking care not to damage the thermocouple and ceramic igniter.
4. Using a 7mm spanner, unscrew the injector. When removing and fitting the injector, the injector holder must be held in place with the aid of a tool (FIG. 9 - PG. 35)
5. Remove retaining washer from thermocouple head.
6. Disconnect appropriate thermocouple lead from gas cock.
7. Remove the thermocouple.
8. Remove retaining spring from ceramic igniter head.
9. Disconnect appropriate ceramic igniter lead from electronic igniter unit.
10. Remove the ceramic igniter.
11. Replace/ refit in reverse procedure.

Oven: injector, burner, thermocouple and ceramic igniter

1. From right hand side of appliance, remove spring from the oven burner inlet.
2. Using a 7mm spanner, unscrew the injector. When removing and fitting the injector, the injector holder must be held in place with the aid of tool (FIG. 9 - PG. 35).
3. Remove lower heat shield at rear and tilt appliance forward.
4. Unscrew the oven burner mounts and lower burner.
5. Remove retaining nut from thermocouple head.
6. Disconnect the oven thermocouple lead from the gas cock.
7. Remove the thermocouple.
8. Remove retaining screw from ceramic igniter support.
9. Disconnect ceramic igniter lead from appropriate electronic igniter unit.
10. Remove the ceramic igniter.
11. Replace/ refit in reverse procedure.

Grill: injector, thermocouple, ceramic igniter and burner

1. From right hand side of appliance, remove spring from the grill burner inlet.
2. Using a 7mm spanner, unscrew the injector. When removing and fitting the injector, the injector holder must be held in place with the aid of tool (FIG. 9 - PG. 35)
3. Remove the protection disk (not present in the CU4... models)
4. Remove retaining nut from thermocouple head.

5. Disconnect the grill thermocouple lead from the gas cock
6. Remove the thermocouple.
7. Remove retaining screw from ceramic igniter support.
8. Disconnect ceramic igniter lead from appropriate electronic igniter unit.
9. Remove the ceramic igniter.
10. Remove the grill burner mounting screws (2) from top.
11. Remove the grill burner mounting spacers (only for CU4... models) and lower burner.

Gas cocks

1. Remove the control knob by pulling.
2. Unscrew gas cock retaining nut.
3. From the underside of the appliance, remove the thermocouple lead and the gas pipe from the gas cock.
4. Remove the appropriate gas cock clamp by unscrewing the screws.
5. Remove the gas cock from the manifold.
6. Replace/ refit in reverse procedure.

Oven thermostat

1. Remove the appropriate control knob by pulling.
2. Unscrew gas cock retaining nut.
3. From the underside of the appliance, remove the thermocouple lead and the gas pipe from the thermostat.
4. Remove the thermostat clamp by unscrewing the screws.
5. Remove the thermostat from the manifold.
6. Open oven door and remove the capillary bulb/ phial from its mount.
7. Remove capillary bulb/ phial through access hole.
8. Replace/ refit in reverse procedure.

Igniter unit/s

1. From the rear right-hand side of appliance, remove electrical connectors from igniter unit/s (noting connection locations).
2. Remove the retaining rivets from appropriate igniter unit.
3. Remove the igniter unit.
4. Replace / refit in reverse procedure.

Oven door

1. Open oven door fully.
2. Remove the door hinge screws (2 each) at either side of the bottom of oven compartment.
3. Remove door from appliance.
4. Replace/ refit in reverse procedure.

230-240 V~ WIRING DIAGRAM

Shown below is the wiring diagram for the 230-240 V~ connection for a stove with electric element on the hotplate.

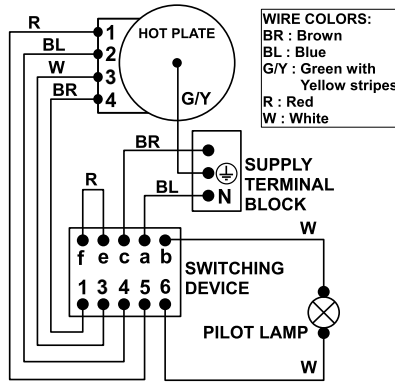

7. WARRANTY

If the product does not work as it should, please contact your retailer or the manufacturer's branch in your country (see dometic.com/dealer). The warranty applicable to your product is 3 year(s).

For repair and warranty processing, please include the following documents when you send in the device:

- A copy of the receipt with purchasing date
- A reason for the claim or description of the fault

Australia only

Our goods come with guarantees that cannot be excluded under the Australian Consumer Law. You are entitled to a replacement or refund for a major failure and for compensation for any other reasonably foreseeable loss or damage. You are also entitled to have the goods repaired or replaced if the goods fail to be of acceptable quality and the failure does not amount to a major failure.

New Zealand only

This warranty policy is subject to the conditions and guarantees which are mandatory as implied by the Consumer Guarantees Act 1993(NZ).

FIGURES AND TECHNICAL DRAWINGS

Figure 1

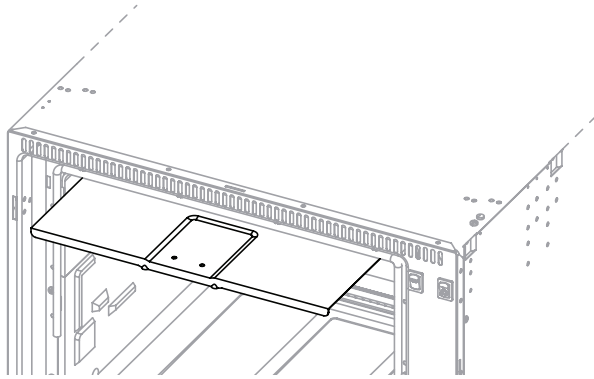

Figure 2

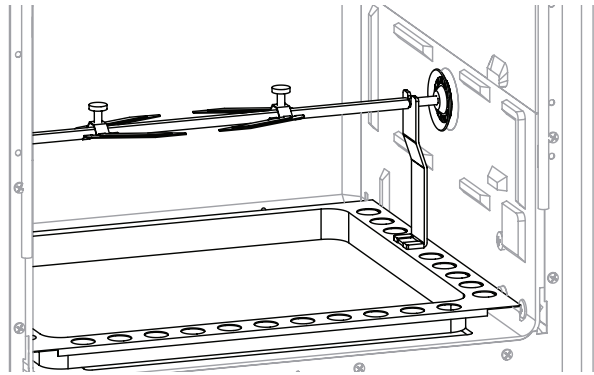

Figure 3

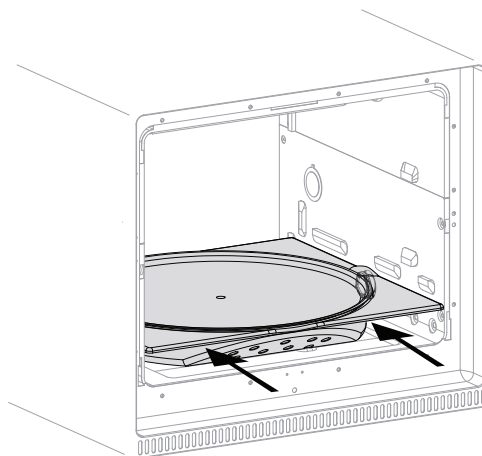
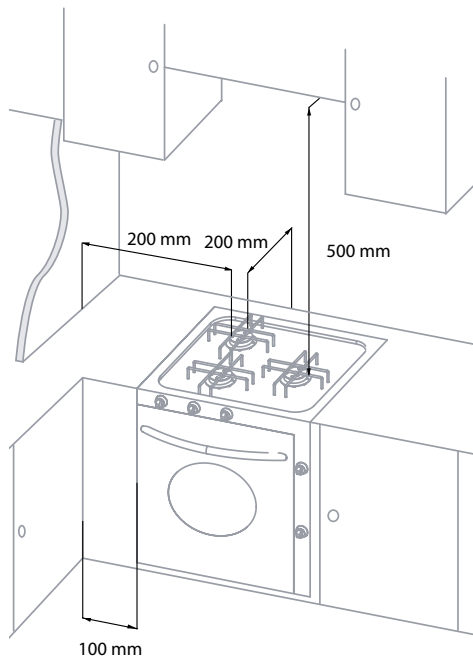
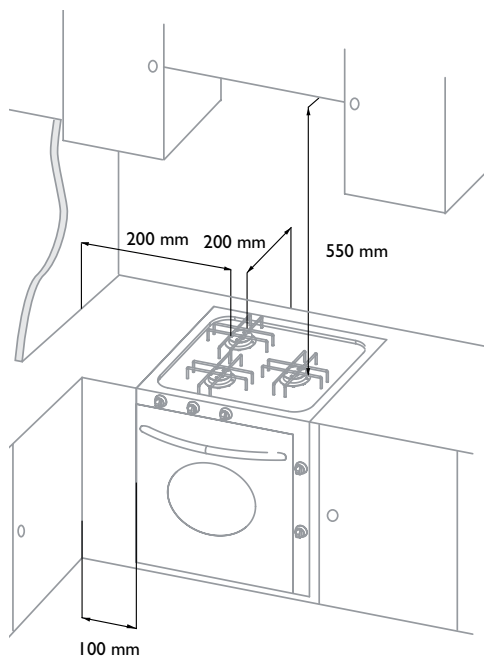

Figure 4



CU311 - CU311M - CU333 - CU333M -
 CU335 - CU335M -
 CU401PE - CU402- CU402PE - CU403 -
 CU403PE -
 MO8103 - MO8123 - MO8302 -
 MO8322 - MO8303 - MO8323 -
 MO9503 - MO9523 - PI0913 - PI0913A -
 PI7903 - PI7923 - PI8002 - PI8022 -
 PI8003 - PI8023 - PI8403 - PI8403GL -
 PI8423 - PI8423GL - PI8443 - PI8463 -
 PI8621A - PI8621S - PI8621R



CU401

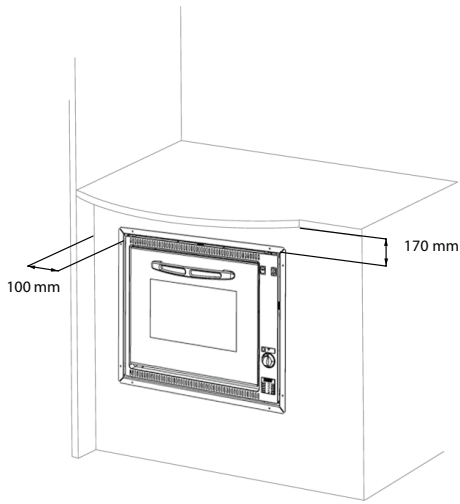

FO311 - VN555

Figure 5

CU311
CU333
CU335

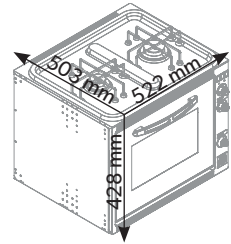

FRONT VIEW

SIDE VIEW

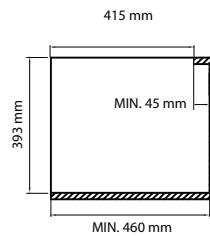
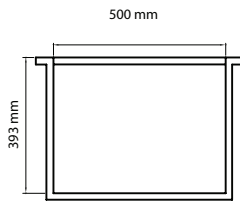

CU311M
 CU333M
 CU335M

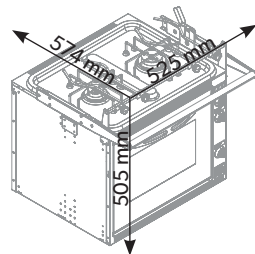
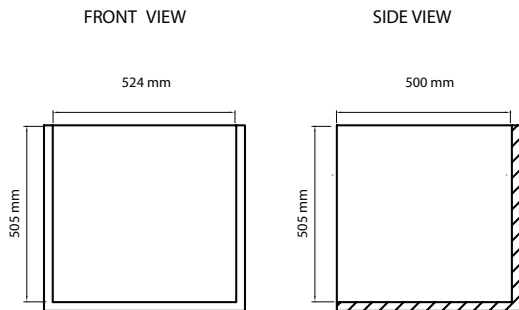

CU401
 CU401PE

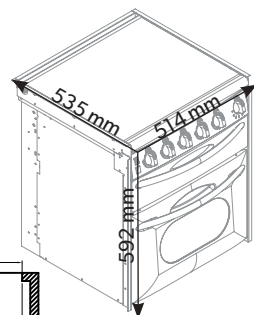
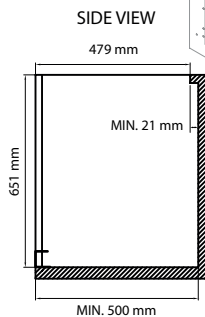
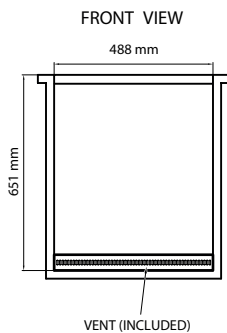
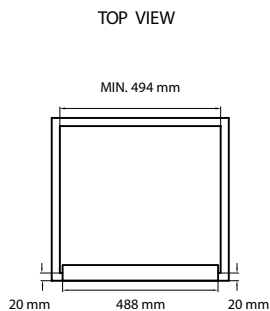

CU402
 CU402PE

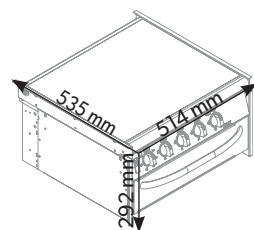
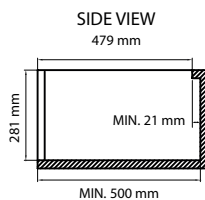
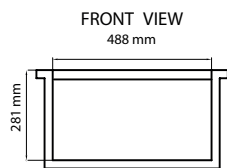
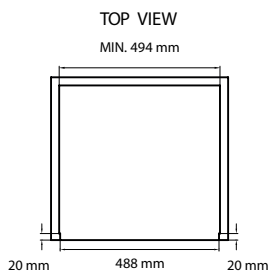

CU403
CU403PE

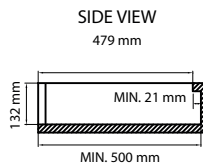
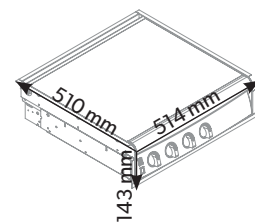
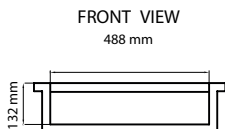
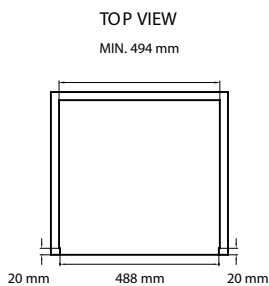

FO311

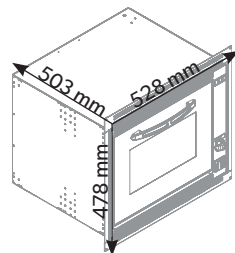
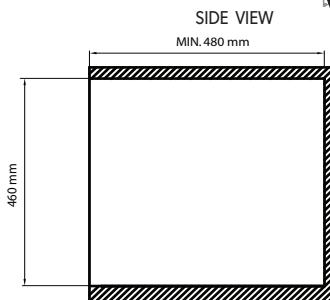
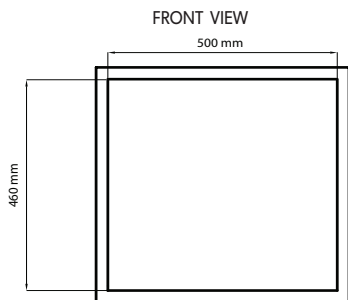

PI0913
PI0913A

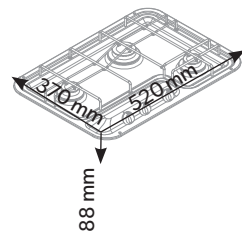
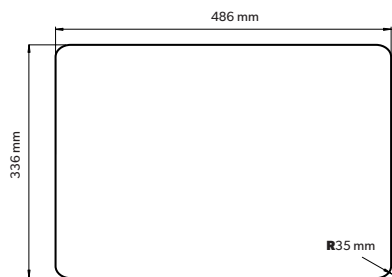

PI8002
PI8022

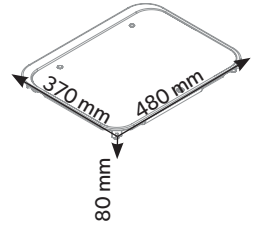
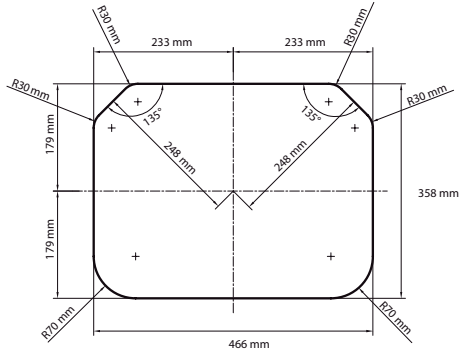

PI8003
PI8023

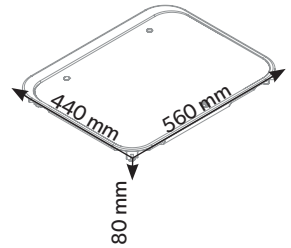
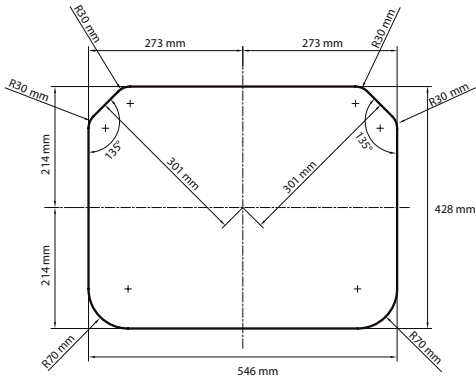

PI8403 - PI8403GL
PI8423 - PI8423GL
PI8443 - PI8463

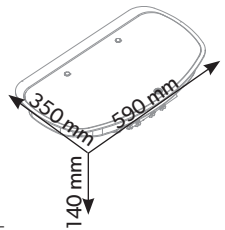
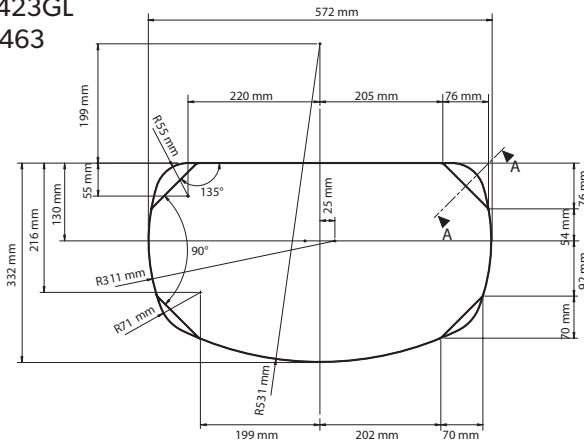

PI8621A
PI8621R
PI8621S

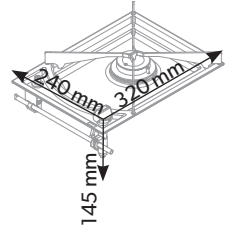
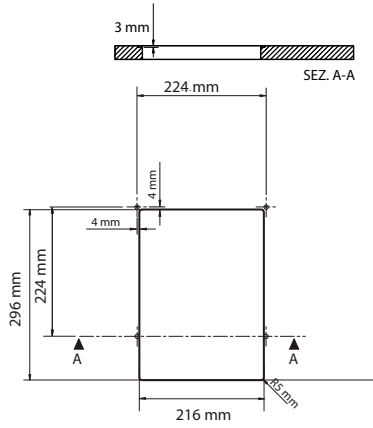

MO8103
MO8123

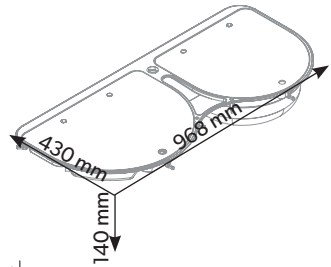
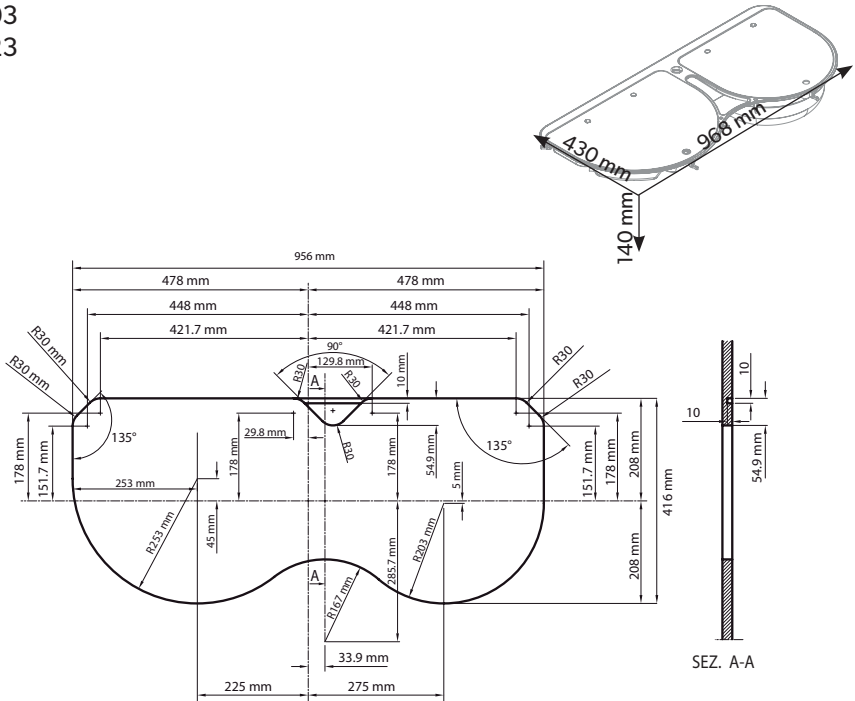

MO8302
 MO8322
 MO8303
 MO8323

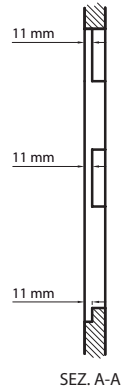
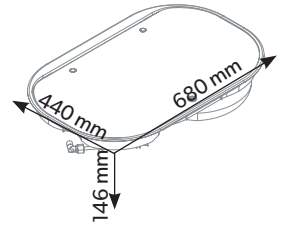
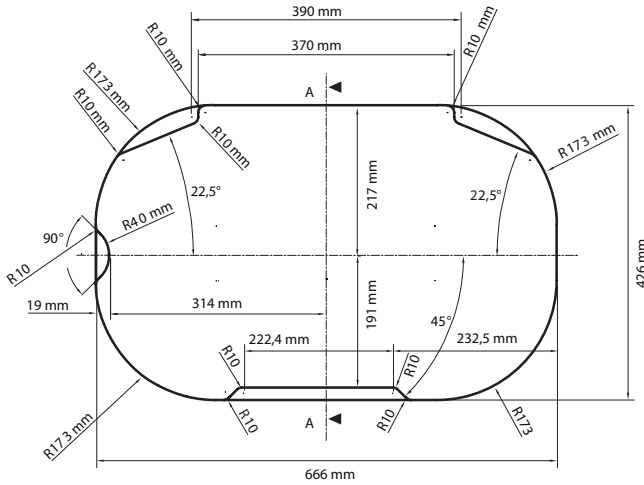

MO9503
 MO9523

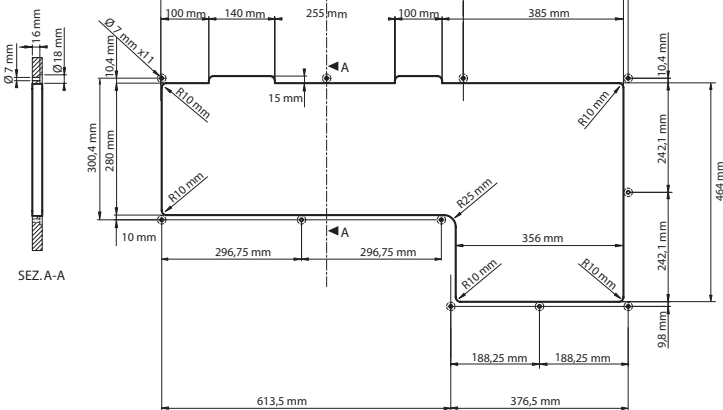
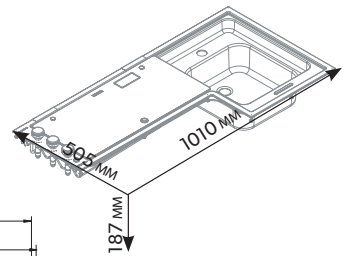
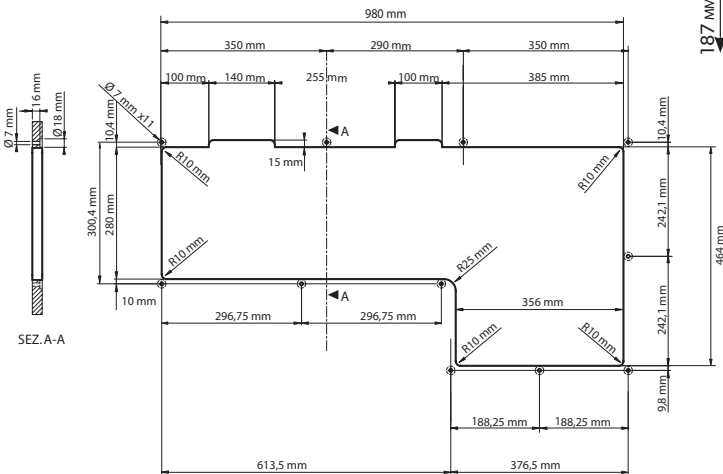

PI7903
PI7923

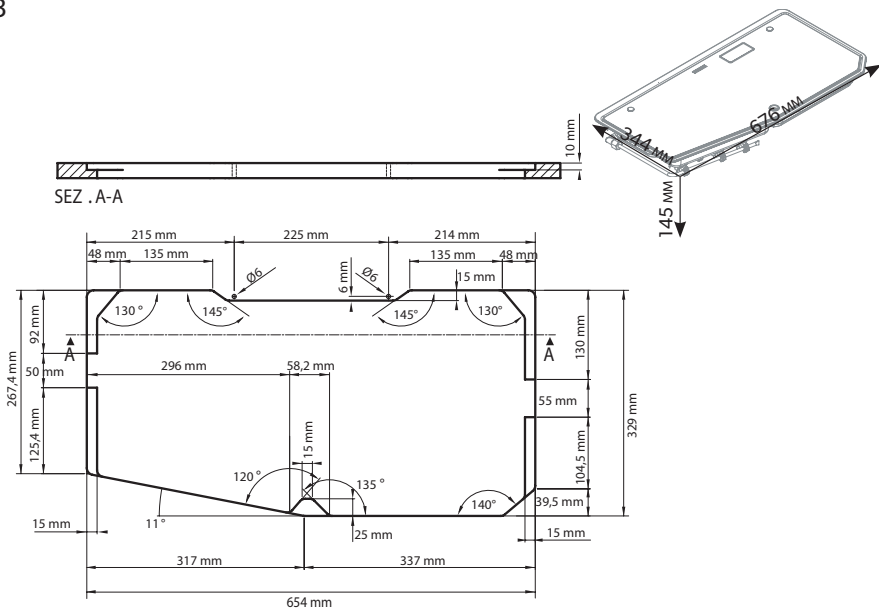

VN555

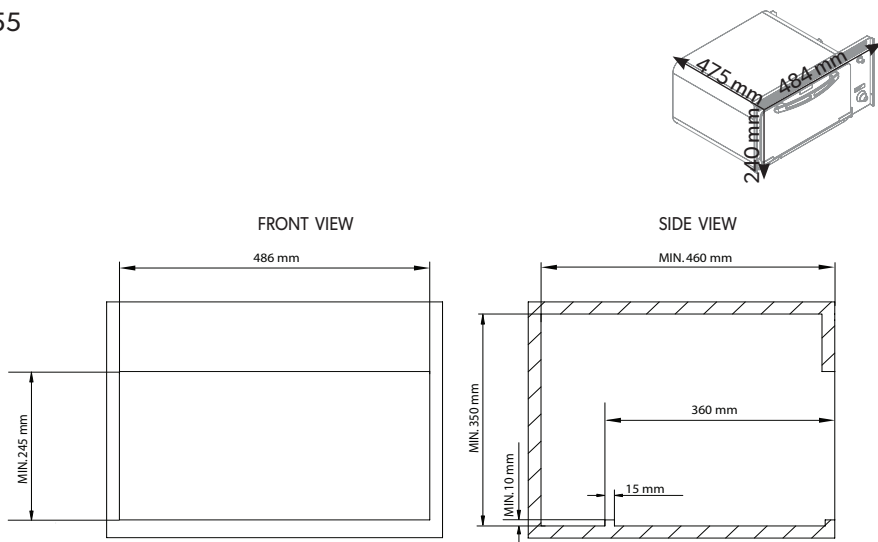
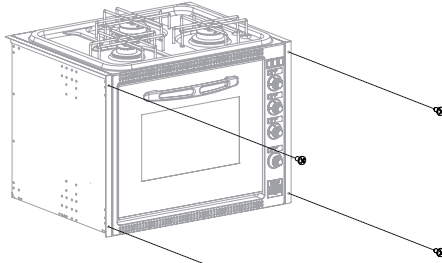
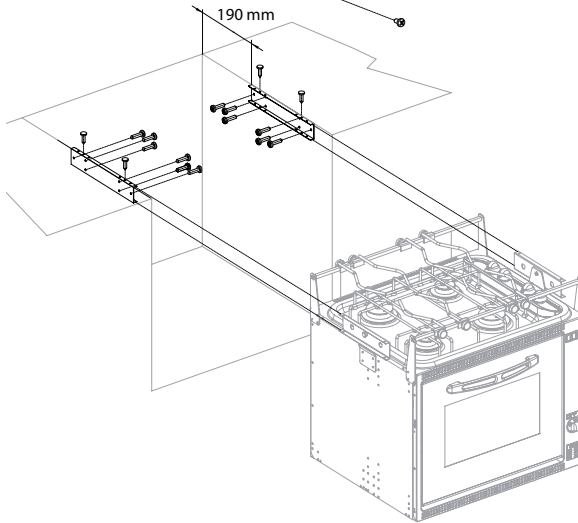
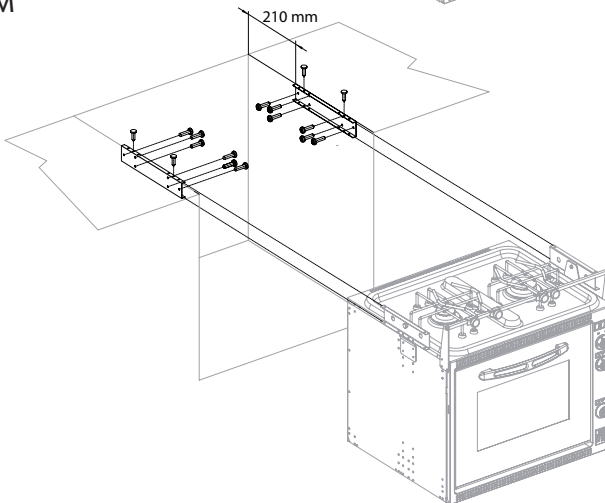

Figure 6

 CU311
 CU333
 CU335

 CU311M
 CU335M

CU333M

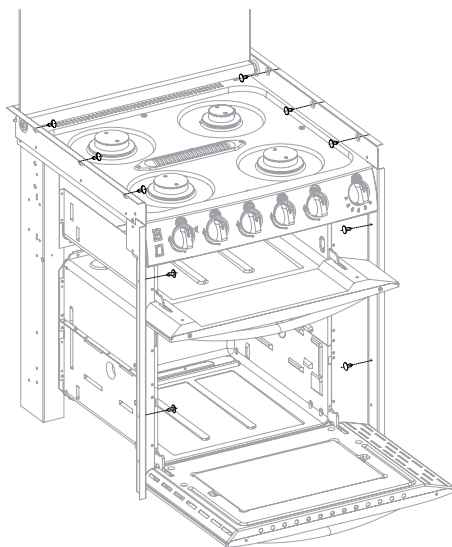

CU401
CU401PE



CU402
CU402PE

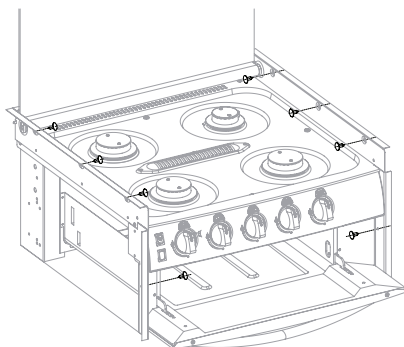

CU403
CU403PE

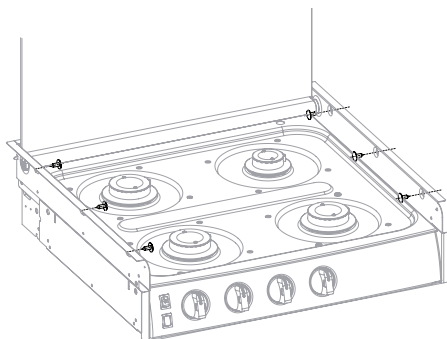

FO311

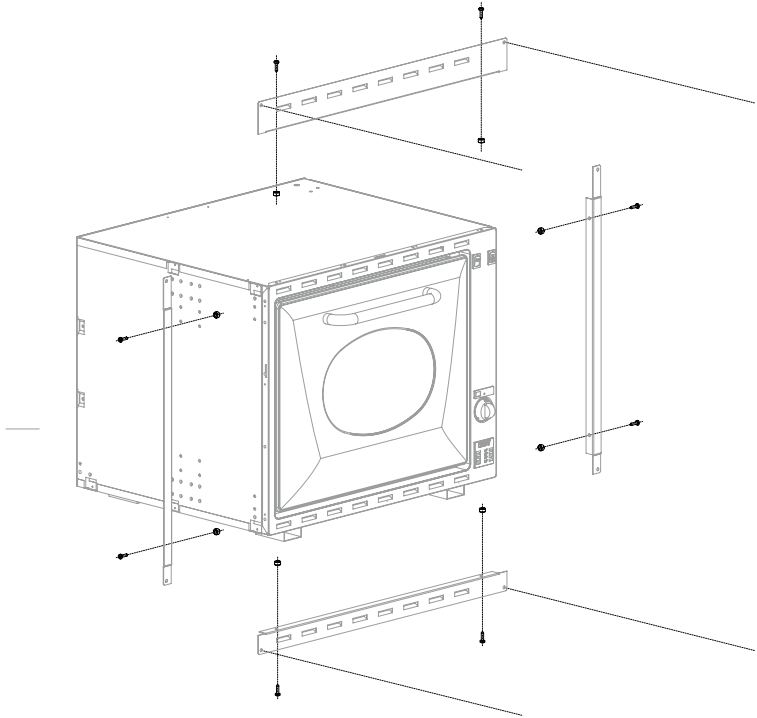

PI0913
PI0913A
PI8621A
PI8621R
PI8621S

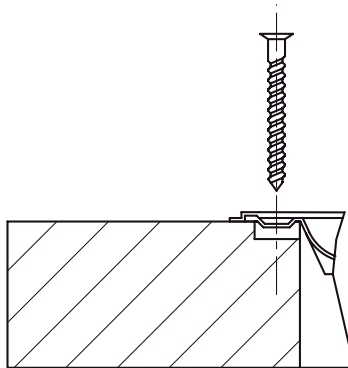

PI8002
PI8022
PI8003
PI8023

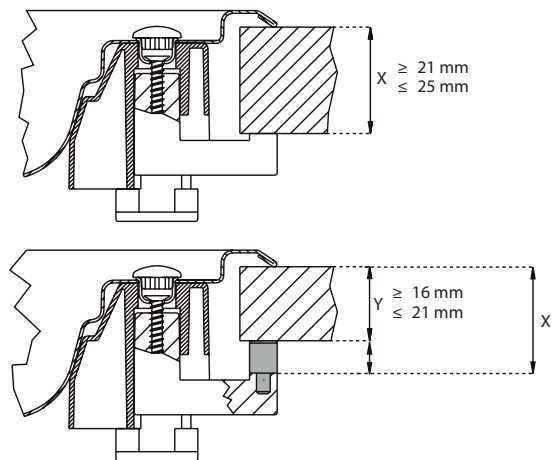

MO8302 - MO8322
MO8303 - MO8323
PI8403 - PI8403GL
PI8423 - PI8423GL
PI8443 - PI8463

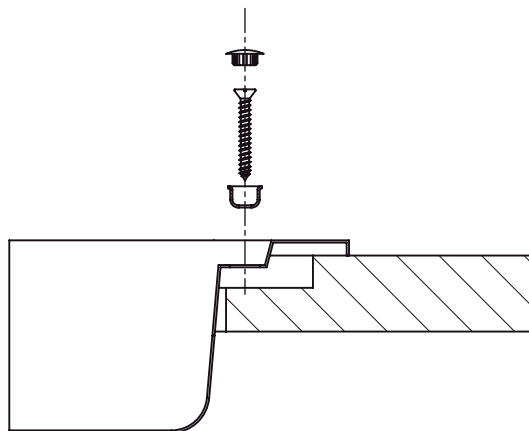

MO8103
 MO8123

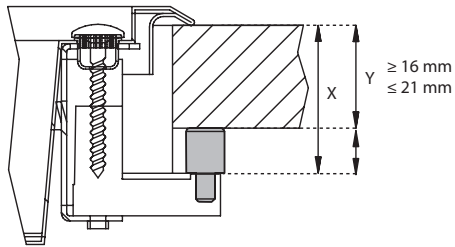
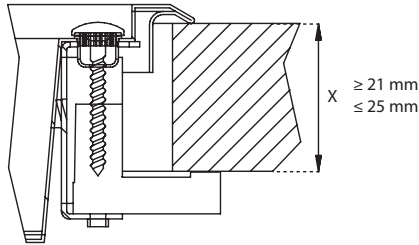

MO9503
 MO9523

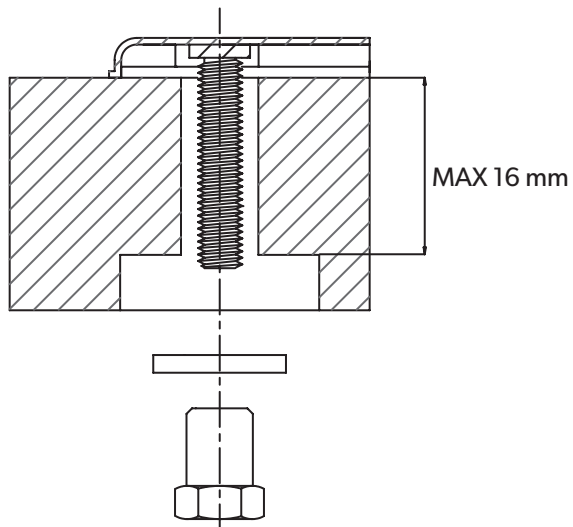

PI7903
PI7923

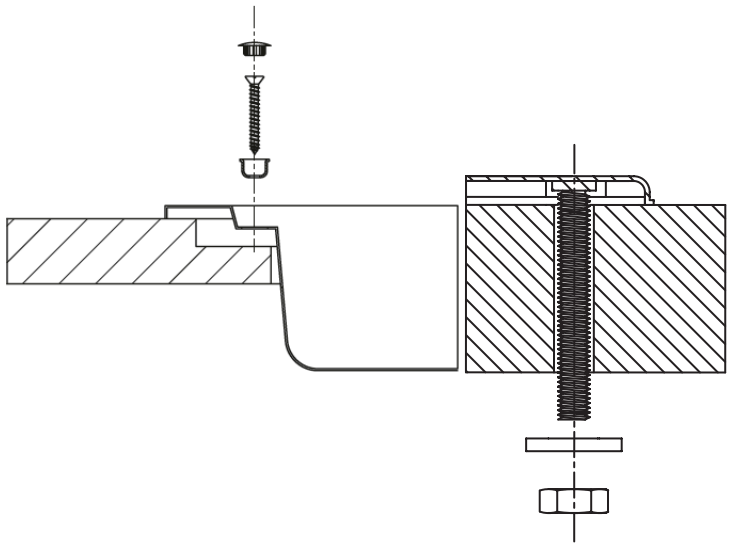

VN555

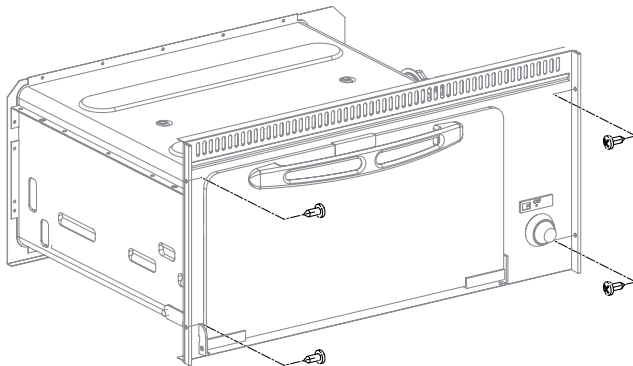

Figure 7



Figure 8

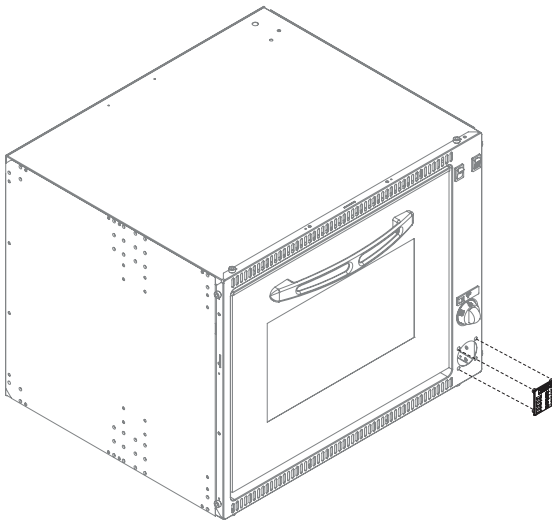

Figure 9



Mobile living made easy.



dometic.com

**YOUR LOCAL
DEALER**

dometic.com/dealer

**YOUR LOCAL
SUPPORT**

dometic.com/contact

**YOUR LOCAL
SALES OFFICE**

dometic.com/sales-offices

A complete list of Dometic companies, which comprise the Dometic Group, can be found in the public filings of:
DOMETIC GROUP AB Hemvärnsgatan 15 SE-17154 Solna Sweden

2021-03-29

4445103302

LIBR51RB_3