

# R&S® SMA100B

## RF Signal Generator

### User Manual



1178383402  
Version 07

**ROHDE & SCHWARZ**  
Make ideas real



This document describes the R&S®SMA100B models, stock no. 1419.8888.02/.04 and its options:

- R&S®SMAB-B1H
- R&S®SMAB-B28
- R&S®SMAB-B29
- R&S®SMAB-B32/-B34/-B35/-B37/-B39
- R&S®SMAB-B80/-B85
- R&S®SMAB-B81/-B82
- R&S®SMAB-B86
- R&S®SMAB-B92/-B93
- R&S®SMAB-B103/-B106/-B112/-B120/-B131/-B140(N)/-B150(N)/-B167(N)
- R&S®SMAB-B709/-B710(N)/-B711(N)
- R&S®SMAB-K22/-K23/-K24/-K27
- R&S®SMAB-K25
- R&S®SMAB-K31/-K33
- R&S®SMAB-K40
- R&S®SMAB-K703
- R&S®SMAB-K704
- R&S®SMAB-K720/-K721
- R&S®SMAB-K722
- R&S®SMAB-K723
- R&S®SMAB-K724
- R&S®SMAB-K725

This manual describes firmware version FW 4.70.205.xx and later of the R&S®SMA100B.

© 2021 Rohde & Schwarz GmbH & Co. KG

Mühlhofstr. 15, 81671 München, Germany

Phone: +49 89 41 29 - 0

Email: [info@rohde-schwarz.com](mailto:info@rohde-schwarz.com)

Internet: [www.rohde-schwarz.com](http://www.rohde-schwarz.com)

Subject to change – data without tolerance limits is not binding.

R&S® is a registered trademark of Rohde & Schwarz GmbH & Co. KG.

Trade names are trademarks of the owners.

1178.3834.02 | Version 07 | R&S®SMA100B

Throughout this manual, products from Rohde & Schwarz are indicated without the ® symbol , e.g. R&S®SMA100B is indicated as R&S SMAB. Linux® is abbreviated as Linux.

# Contents

<b>1</b>	<b>Preface</b> .....	<b>19</b>
1.1	<b>Key Features</b> .....	<b>19</b>
1.2	<b>About this Manual</b> .....	<b>19</b>
1.3	<b>Documentation Overview</b> .....	<b>20</b>
1.3.1	Getting Started Manual.....	21
1.3.2	User Manuals and Help.....	21
1.3.3	Service Manual.....	21
1.3.4	Instrument Security Procedures.....	21
1.3.5	Printed Safety Instructions.....	21
1.3.6	Data Sheets and Brochures.....	21
1.3.7	Release Notes and Open Source Acknowledgment (OSA).....	22
1.3.8	Application Notes, Application Cards, White Papers, etc.....	22
<b>2</b>	<b>Safety and Regulatory Information</b> .....	<b>23</b>
2.1	<b>Safety Instructions</b> .....	<b>23</b>
2.2	<b>Labels on R&amp;S SMA100B</b> .....	<b>25</b>
2.3	<b>Korea Certification Class A</b> .....	<b>26</b>
<b>3</b>	<b>Getting Started</b> .....	<b>27</b>
3.1	<b>Preparing for Use</b> .....	<b>27</b>
3.1.1	Lifting and Carrying.....	27
3.1.2	Unpacking and Checking.....	27
3.1.3	Choosing the Operating Site.....	27
3.1.4	Setting Up the R&S SMA100B.....	28
3.1.4.1	Placing the R&S SMA100B on a Bench Top.....	28
3.1.4.2	Mounting the R&S SMA100B in a Rack.....	29
3.1.5	Important Aspects for Test Setup.....	30
3.1.6	Connecting to Power.....	31
3.1.7	Connecting to LAN.....	31
3.1.8	Connecting USB Devices.....	32
3.1.9	Connecting to RF.....	32
3.1.10	Connecting to Ref In/Ref Out.....	34
3.1.11	Switching On or Off.....	35

<b>3.2 Instrument Tour.....</b>	<b>36</b>
3.2.1 Front Panel Tour.....	37
3.2.1.1 Touchscreen.....	38
3.2.1.2 Utility Keys.....	38
3.2.1.3 On/Standby.....	39
3.2.1.4 Function Keys.....	39
3.2.1.5 Keypad.....	39
3.2.1.6 Navigation Controls.....	40
Rotary Knob.....	40
Editing Keys.....	40
Navigation Keys.....	40
3.2.1.7 Display Keys.....	41
3.2.1.8 USB Connector.....	41
3.2.1.9 SD card slot.....	41
3.2.1.10 Sensor.....	42
3.2.1.11 RF 50 Ω.....	42
3.2.1.12 Pulse Signal Connectors.....	43
3.2.1.13 LF Modulation Connectors.....	43
3.2.1.14 Clock Synthesizer Connectors.....	43
3.2.2 Rear Panel Tour.....	44
3.2.2.1 Connectors.....	45
<b>3.3 Trying Out the Instrument.....</b>	<b>47</b>
3.3.1 Generating an Unmodulated Carrier.....	48
3.3.2 Generating an RF Frequency Sweep Signal.....	50
3.3.3 Saving and Recalling Settings.....	52
<b>3.4 Instrument Control.....</b>	<b>55</b>
3.4.1 Possible Ways to Operate the Instrument.....	56
3.4.2 Means of Manual Interaction.....	56
3.4.3 Understanding the Display Information.....	57
3.4.3.1 Status Bar.....	57
3.4.3.2 Tile Diagram.....	57
3.4.3.3 Taskbar.....	58
3.4.3.4 Additional Display Characteristics.....	59



3.4.4	Accessing the Functionality.....	60
3.4.5	Entering Data.....	61
3.4.5.1	Entering Numeric Parameters.....	62
3.4.5.2	Entering Alphanumeric Parameters.....	62
3.4.5.3	Undo and Redo Actions.....	62
3.4.6	Getting Information and Help.....	62
3.4.7	Remote Control.....	64
3.4.8	Remote Operation over VNC.....	65
<b>4</b>	<b>RF Signal Configuration.....</b>	<b>66</b>
4.1	Activating RF Signal Output.....	67
4.2	How to Set the Frequency and Level.....	67
4.3	RF Connector Settings.....	69
4.4	RF Frequency Settings.....	71
4.5	RF Level Settings.....	74
4.6	RF Phase Settings.....	78
<b>5</b>	<b>Analog Modulations.....</b>	<b>80</b>
5.1	Required Options.....	80
5.2	Modulation Types and Signal Sources.....	80
5.3	Activating Analog Modulations.....	82
5.4	Modulation Settings.....	83
5.4.1	Pulse Modulation.....	83
5.4.2	FM, PhiM and AM Modulation Settings.....	85
5.4.3	Chirp Modulation.....	92
5.4.3.1	Chirp Modulation Settings.....	94
	Chirp Modulation.....	94
	Pulse External / Trigger .....	97
5.4.4	Pulse Generator.....	97
5.4.4.1	Pulse Generator > General Settings.....	98
5.4.4.2	Pulse Generator > Pulse Train Settings.....	103
5.4.4.3	Import/Export List Files.....	107
5.4.5	Pulse Graph.....	110
5.4.6	Pulse External / Trigger Settings.....	111
5.4.7	FM, PhiM and AM Modulation Sources.....	112

5.4.7.1	Source > LF Generator Settings.....	112
5.4.7.2	Source > External Settings.....	116
5.4.7.3	Source > Noise Generator Settings.....	118
5.4.8	LF Signal Output Settings.....	119
5.4.9	Overview.....	121
<b>5.5</b>	<b>How to Generate an Amplitude Modulated Signal.....</b>	<b>123</b>
<b>5.6</b>	<b>How to Generate a Pulse Modulated Signal.....</b>	<b>123</b>
<b>5.7</b>	<b>How to Generate a Pulse Train Modulated Signal.....</b>	<b>124</b>
<b>6</b>	<b>Avionic Standards.....</b>	<b>126</b>
<b>6.1</b>	<b>Required Options.....</b>	<b>126</b>
<b>6.2</b>	<b>About the Avionics Options.....</b>	<b>126</b>
6.2.1	VHF Omni Directional Radio Range (VOR).....	127
6.2.2	Instrument Landing System (ILS).....	128
6.2.3	Automatic Direction Finder (ADF).....	131
<b>6.3</b>	<b>VOR Configuration and Settings.....</b>	<b>132</b>
6.3.1	General Settings.....	132
6.3.2	Signal Settings.....	135
6.3.3	Position Settings.....	137
6.3.4	COM/ID Settings.....	138
<b>6.4</b>	<b>ILS Configuration and Settings.....</b>	<b>140</b>
6.4.1	General Settings.....	140
6.4.2	ILS Glide Slope Settings.....	143
6.4.2.1	General Settings.....	143
6.4.2.2	Signal Settings.....	145
6.4.2.3	Amplitude Settings.....	147
6.4.3	ILS Localizer Settings.....	149
6.4.3.1	General Settings .....	150
6.4.3.2	Signal Settings.....	152
6.4.3.3	Amplitude Settings.....	153
6.4.3.4	COM/ID Settings.....	156
6.4.4	ILS Marker Beacons Settings.....	158
6.4.4.1	General Settings.....	159
6.4.4.2	Signal Settings.....	160

6.4.4.3	COM/ID Settings.....	161
<b>6.5</b>	<b>ADF Configuration and Settings.....</b>	<b>163</b>
6.5.1	General Settings.....	164
6.5.2	COM/ID Settings.....	166
<b>7</b>	<b>List and Sweep Mode.....</b>	<b>169</b>
<b>7.1</b>	<b>Signal Generation and Triggering in the Sweep and List Modes.....</b>	<b>171</b>
<b>7.2</b>	<b>About Sweep Mode.....</b>	<b>178</b>
7.2.1	Correlating Parameters in Sweep Mode.....	179
7.2.2	Sweep Signal Shapes.....	181
<b>7.3</b>	<b>About List Mode.....</b>	<b>182</b>
<b>7.4</b>	<b>Significant Parameters and Functions.....</b>	<b>183</b>
<b>7.5</b>	<b>Sweep Mode Settings.....</b>	<b>185</b>
7.5.1	General Sweep Settings.....	185
7.5.2	Frequency Range Settings.....	192
7.5.3	Level Range Settings.....	194
7.5.4	Output Settings.....	196
7.5.5	Edit Marker Settings.....	197
<b>7.6</b>	<b>List Mode Settings.....</b>	<b>199</b>
7.6.1	General Settings.....	200
7.6.2	List Mode Data Settings.....	202
7.6.3	Import/Export Settings.....	203
<b>7.7</b>	<b>List Editor.....</b>	<b>205</b>
<b>7.8</b>	<b>How to Generate a Signal in List or Sweep Mode.....</b>	<b>209</b>
<b>8</b>	<b>Improving Level Performance.....</b>	<b>211</b>
<b>8.1</b>	<b>Attenuator.....</b>	<b>211</b>
8.1.1	Attenuator Settings.....	212
8.1.2	Reverse Power Protection.....	214
<b>8.2</b>	<b>Automatic Level Control (ALC).....</b>	<b>214</b>
8.2.1	ALC Settings.....	215
<b>8.3</b>	<b>User Correction.....</b>	<b>216</b>
8.3.1	User Correction Settings.....	219
8.3.2	List Editor.....	221
8.3.3	Fill with Sensor.....	224

8.3.4	Import/Export List Files.....	226
<b>8.4</b>	<b>Using Power Sensors.....</b>	<b>228</b>
8.4.1	Connecting R&S NRP Power Sensors to the R&S SMA100B.....	229
8.4.2	NRP Sensor Mapping.....	230
8.4.3	NRP Power Viewer.....	233
8.4.3.1	About.....	233
8.4.3.2	NRP Power Viewer Settings.....	235
8.4.4	NRP-Z Power Analysis.....	240
8.4.4.1	Required Options.....	240
8.4.4.2	About.....	241
8.4.4.3	Accessing the NRP-Z Power Analysis Functionality.....	243
8.4.4.4	Test Setup Example.....	245
8.4.4.5	NRP-Z Traces/Markers Settings.....	245
	Traces Settings.....	247
	Markers Settings.....	249
8.4.4.6	NRP-Z Configure Settings.....	250
	Configure Measurement Settings.....	250
	Configure Sensors Settings.....	254
	Configure Diagram.....	257
	Configure Time Mode Settings.....	259
	Trace Settings.....	259
	Pulse Data Notifications Settings.....	261
	Trigger Settings.....	266
	Gate Mode Settings.....	268
	Next Window List.....	270
8.4.4.7	Creating Screenshots of Power Analysis Settings .....	274
	Save (Power Analysis) Settings.....	274
	How to Save a Hardcopy of the Power Analysis Window.....	279
8.4.4.8	How to Setup a Frequency Sweep Measurement.....	281
8.4.4.9	How to Setup a Power Sweep Measurement.....	282
8.4.4.10	How to Setup a Pulse Measurement.....	282
8.4.4.11	How to Configure the Power Analysis Diagram.....	283
<b>8.5</b>	<b>How to Calibrate the Power Level with an R&amp;S NRP Power Sensor.....</b>	<b>284</b>

<b>9</b>	<b>Reference Oscillator.....</b>	<b>288</b>
9.1	Required Options.....	288
9.2	Reference Frequency Settings.....	288
9.3	Reference Output Settings.....	292
9.4	Adjustment Settings.....	293
9.5	Using the Reference Frequency for Instruments Synchronization.....	294
<b>10</b>	<b>Clock Synthesis.....</b>	<b>298</b>
<b>11</b>	<b>File and Data Management.....</b>	<b>302</b>
11.1	About the File System.....	302
11.2	Restoring the (Default) Instrument Configuration.....	305
11.2.1	Preset, Set to Default and Factory Preset Settings.....	307
11.2.2	How to Identify Parameters Which Are Not in a Preset State.....	308
11.2.3	How to Recall User Settings Automatically after Preset.....	309
11.2.4	Reference.....	309
11.3	Protecting Data.....	310
11.4	Saving and Recalling Instrument Settings.....	311
11.4.1	Save/Recall Settings.....	311
11.4.2	How to Save and Recall Instrument Settings.....	314
11.5	Accessing Files with User Data.....	315
11.5.1	File Select Settings.....	315
11.6	Exporting and Importing Remote Command Lists.....	317
11.7	Loading, Importing and Exporting Lists.....	318
11.8	Using the File Manager.....	318
11.8.1	File Manager Settings.....	319
11.8.2	Map Network Share Settings.....	320
11.8.3	How to Display All Saved Files.....	322
11.8.4	How to Map a Network Folder.....	322
11.9	How to Transfer Files from and to the Instrument.....	325
11.9.1	Removing File System Protection.....	325
11.9.2	Accessing the File System of the R&S SMA100B via ftp.....	327
11.9.3	Accessing the R&S SMA100B File System via SMB (Samba).....	328
11.9.4	Using a USB Storage Device for File Transfer.....	330
11.9.5	Using a File Server for Test Files Exchange.....	330

<b>11.10</b>	<b>Creating Screenshots of Current Settings.....</b>	<b>331</b>
11.10.1	Hardcopy Settings.....	331
11.10.2	How to Save a Hardcopy of the Display.....	335
<b>12</b>	<b>General Instrument Functions.....</b>	<b>337</b>
<b>12.1</b>	<b>Customizing the User Interface.....</b>	<b>337</b>
12.1.1	Display and Keyboard Settings.....	338
12.1.2	Display Update Settings.....	339
12.1.3	Defining the RF Signal State On Power On .....	340
12.1.4	How to Set the Initial Instrument Settings.....	341
12.1.4.1	Setting the Keyboard Language.....	341
12.1.4.2	Setting the Screen Saver.....	341
<b>12.2</b>	<b>Organizing Frequently Used Settings as Favorites.....</b>	<b>342</b>
12.2.1	User Menu Settings.....	343
12.2.2	How To Use the User Menu for Fast Adjustments.....	344
12.2.3	Define User Key Actions Settings.....	346
12.2.4	How to Assign Actions to the [★ (User)] Key.....	348
<b>12.3</b>	<b>Managing Licenses and License Keys.....</b>	<b>349</b>
12.3.1	Manage License Keys Settings.....	349
12.3.2	How to Move a Portable License.....	352
<b>12.4</b>	<b>Using the Security Settings.....</b>	<b>353</b>
12.4.1	Protection Level Settings.....	354
12.4.2	Setting Security Parameters.....	355
12.4.2.1	Update Policy Security Settings.....	356
12.4.2.2	Disk & Memory Security Settings.....	357
12.4.2.3	Manual Operation Security Settings.....	358
12.4.3	Configuring LAN Services.....	361
12.4.4	Password Management.....	363
12.4.5	How to Prevent Unauthorized Access.....	365
<b>12.5</b>	<b>Undoing or Restoring Actions.....</b>	<b>368</b>
<b>12.6</b>	<b>Shutting Down and Rebooting the Instrument.....</b>	<b>370</b>
<b>13</b>	<b>Network Operation and Remote Control.....</b>	<b>371</b>
<b>13.1</b>	<b>Overview of Remote Access Modes.....</b>	<b>371</b>
<b>13.2</b>	<b>Remote Control Interfaces and Protocols.....</b>	<b>373</b>

13.2.1	LAN Interface.....	374
13.2.1.1	VISA Resource Strings.....	374
13.2.1.2	HiSLIP Protocol.....	376
13.2.1.3	VXI-11 Protocol.....	376
13.2.1.4	Socket Communication.....	376
13.2.2	USB Interface.....	377
13.2.2.1	USB Resource String.....	377
13.2.3	GPIB Interface (IEC/IEEE Bus Interface).....	377
13.2.4	LXI Browser Interface.....	378
<b>13.3</b>	<b>Remote Control Programs and Libraries.....</b>	<b>379</b>
13.3.1	VISA Library.....	379
13.3.2	Possible Setups and Access Functions.....	380
<b>13.4</b>	<b>Remote Access Settings.....</b>	<b>382</b>
13.4.1	Network Settings.....	383
13.4.2	VISA Resource Strings.....	385
13.4.3	GPIB Address Settings.....	386
13.4.4	RS232 Settings.....	387
13.4.5	Instrument Emulations Settings.....	388
13.4.6	Remote Connections Settings.....	389
13.4.6.1	Active Connections.....	389
13.4.6.2	Closed Connections.....	390
13.4.7	QR Code.....	391
<b>13.5</b>	<b>LXI Settings.....</b>	<b>392</b>
13.5.1	LXI Status Settings.....	392
13.5.2	LXI Browser Settings.....	394
13.5.2.1	LAN Configuration.....	395
	IP Configuration.....	395
	Advanced Config.....	396
	Ping Client.....	397
	SCPI Remote Trace.....	397
	Data Sheet.....	399
<b>13.6</b>	<b>Connecting the Instrument to the Network (LAN).....</b>	<b>399</b>
13.6.1	How To Enable Access via LAN.....	400

13.6.2	How To Activate LAN Services.....	400
13.6.3	How To Connect to LAN.....	400
13.6.4	How to Assign the IP Address.....	400
13.6.5	How to Use Computer Names (Hostnames).....	401
<b>13.7</b>	<b>Controlling the R&amp;S SMA100B Remotely.....</b>	<b>402</b>
13.7.1	How to Find the VISA Resource String.....	403
13.7.2	How to Change the GPIB Instrument Address.....	404
13.7.3	Establishing a Remote Control Connection over the LXI Browser Interface.....	404
13.7.4	Establishing a Remote Control Connection over LAN Using VXI-11 Protocol.....	405
13.7.5	Establishing a Remote Control Connection over LAN Using Socket Communication .....	410
13.7.6	Setting Up a Remote Control Connection over GPIB.....	411
13.7.7	Setting Up a Remote Control Connection over USB.....	412
13.7.8	How to Trace Messages with the LXI Web Browser Interface.....	413
13.7.9	How to Return to Manual Operation.....	413
<b>13.8</b>	<b>Automating Tasks with Remote Command Scripts.....</b>	<b>414</b>
13.8.1	Show SCPI Command.....	417
13.8.2	Displaying an SCPI List.....	417
13.8.3	SCPI Recording Export Settings.....	418
13.8.4	How to Record / Create SCPI Lists.....	419
13.8.5	How to Convert and Save SCPI Lists.....	422
13.8.6	How to Find Out the SCPI Commands for GUI Functions.....	423
<b>13.9</b>	<b>Operating the R&amp;S SMA100B Remotely via VNC.....</b>	<b>424</b>
13.9.1	How To Enable the VNC Service.....	424
13.9.2	How To Set Up a Remote Operation from a Desktop System.....	425
13.9.2.1	Using a Web Browser.....	425
13.9.2.2	Using a VNC Client Software.....	425
13.9.3	How To Set Up a Remote Operation from a Smart Device.....	427
13.9.3.1	Using a VNC App.....	428
13.9.3.2	Using a Web Browser with HTML5.....	428
13.9.3.3	Special Mode QR Code .....	429
<b>13.10</b>	<b>References.....</b>	<b>430</b>
13.10.1	LXI Functionality.....	430
13.10.2	Code Generator Templates.....	430



13.10.3	Remote Control States .....	432
<b>14</b>	<b>Remote Control Commands.....</b>	<b>434</b>
<b>14.1</b>	<b>Conventions Used in SCPI Command Descriptions.....</b>	<b>434</b>
<b>14.2</b>	<b>Programming Examples.....</b>	<b>435</b>
<b>14.3</b>	<b>Common Commands.....</b>	<b>435</b>
<b>14.4</b>	<b>Preset Commands.....</b>	<b>440</b>
<b>14.5</b>	<b>MMEMory Subsystem.....</b>	<b>441</b>
14.5.1	File Naming Conventions.....	442
14.5.2	Accessing Files in the Default or in a Specified Directory.....	443
14.5.3	Programming Examples.....	444
14.5.4	Remote Control Commands.....	446
<b>14.6</b>	<b>CALibration Subsystem.....</b>	<b>452</b>
<b>14.7</b>	<b>CSYNthesis Subsystem.....</b>	<b>454</b>
<b>14.8</b>	<b>DIAGnostic Subsystem.....</b>	<b>459</b>
<b>14.9</b>	<b>DISPlay Subsystem.....</b>	<b>462</b>
<b>14.10</b>	<b>FORMat Subsystem.....</b>	<b>467</b>
<b>14.11</b>	<b>HCOPY Subsystem.....</b>	<b>468</b>
14.11.1	Hard Copy Settings.....	469
14.11.2	Automatic Naming.....	471
<b>14.12</b>	<b>KBOard Subsystem.....</b>	<b>473</b>
<b>14.13</b>	<b>OUTPut Subsystem.....</b>	<b>474</b>
<b>14.14</b>	<b>Power Sensor Measurement Subsystems.....</b>	<b>478</b>
14.14.1	CALCulate Subsystem.....	479
14.14.2	DISPlay Subsystem.....	483
14.14.3	INITiate Command.....	484
14.14.4	SENSE SWEEP Subsystem.....	484
14.14.5	TRACe Subsystem.....	517
<b>14.15</b>	<b>SENSE, READ, INITiate and SLISt Subsystems.....</b>	<b>527</b>
<b>14.16</b>	<b>SOURce Subsystem.....</b>	<b>542</b>
14.16.1	Analog Modulation Subsystems.....	543
14.16.1.1	SOURce:MODulation Subsystem.....	543
14.16.1.2	SOURce:AM Subsystem.....	544
14.16.1.3	SOURce:CHIRp Subsystem.....	550

14.16.1.4	SOURce:FM Subsystem.....	554
14.16.1.5	SOURce:PM Subsystem.....	559
14.16.1.6	SOURce:PULM Subsystem.....	563
	Pulse Modulation Settings.....	563
	Pulse Train Settings.....	569
	Pulse Train Data Exchange.....	571
14.16.2	Avionic Standards Subsystems.....	574
14.16.2.1	Programming Examples.....	575
14.16.2.2	General Commands.....	579
14.16.2.3	SOURce:ADF Subsystem.....	582
14.16.2.4	SOURce:ILS Subsystem.....	585
14.16.2.5	SOURce:VOR Subsystem.....	607
14.16.3	SOURce:CORRection Subsystem.....	616
14.16.3.1	Correction Settings.....	619
14.16.3.2	Correction Data Exchange.....	622
14.16.4	SOURce:FREQuency Subsystem.....	624
14.16.5	SOURce:INPut Subsystem.....	631
14.16.6	SOURce:LFOuTput Subsystem.....	632
14.16.6.1	LF Generator Settings.....	634
14.16.6.2	LF Sweep Settings.....	641
14.16.7	SOURce:LIST Subsystem.....	645
14.16.7.1	List Mode Settings.....	648
14.16.7.2	List Mode File Operation.....	653
14.16.7.3	List Mode Data Exchange.....	655
14.16.8	SOURce:NOISe Subsystem.....	657
14.16.8.1	Noise Generator.....	658
14.16.9	SOURce:PGEN Subsystem.....	659
14.16.10	SOURce:PHASe Subsystem.....	661
14.16.11	SOURce:POWer Subsystem.....	662
14.16.12	SOURce:ROSCillator Subsystem.....	671
14.16.13	SOURce:SWEep Subsystem.....	676
<b>14.17</b>	<b>SYSTem Subsystem.....</b>	<b>690</b>
<b>14.18</b>	<b>STATus Subsystem.....</b>	<b>715</b>

14.19	<b>TEST Subsystem</b> .....	718
14.20	<b>TRIGger Subsystem</b> .....	719
14.21	<b>UNIT Subsystem</b> .....	723
<b>15</b>	<b>Troubleshooting and Error Messages</b> .....	<b>724</b>
15.1	<b>Error Messages</b> .....	724
15.1.1	Volatile Messages.....	724
15.1.2	Permanent Messages.....	724
15.2	<b>SCPI-Error Messages</b> .....	<b>725</b>
15.3	<b>Device-Specific Error Messages</b> .....	<b>725</b>
15.4	<b>Querying Error Messages</b> .....	<b>727</b>
15.5	<b>Resolving Network Connection Failures</b> .....	<b>729</b>
15.6	<b>Measuring USB cable quality</b> .....	<b>730</b>
15.7	<b>Requesting Instrument Configuration and Specifications</b> .....	<b>730</b>
15.7.1	Hardware Configuration Settings.....	730
15.7.2	Versions/Options Settings.....	732
15.7.3	How to Query Instrument Configuration.....	733
15.7.4	How to Request the Data Sheet.....	735
15.8	<b>Collecting Information for Technical Support</b> .....	<b>735</b>
15.9	<b>Contacting Customer Support</b> .....	<b>736</b>
<b>16</b>	<b>Transporting</b> .....	<b>738</b>
<b>17</b>	<b>Maintenance, Storage and Disposal</b> .....	<b>739</b>
17.1	<b>Cleaning</b> .....	<b>739</b>
17.2	<b>Storage</b> .....	<b>739</b>
17.3	<b>Performing Maintenance Tasks</b> .....	<b>739</b>
17.3.1	Date and Time.....	739
17.3.1.1	Data and Time Settings.....	740
17.3.1.2	How To Set Data and Time.....	741
17.3.2	Check Front Panel.....	742
17.3.2.1	Check Front Panel Settings.....	742
17.3.2.2	How to Test the Front Panel.....	742
17.3.3	Internal Adjustments.....	744
17.3.3.1	Internal Adjustments Settings.....	745

17.3.3.2	How to Use the Internal Adjustments.....	746
17.3.4	FPGA/uC Update Settings.....	748
17.3.5	Exchanging the RF Adapter Port.....	749
<b>17.4</b>	<b>Disposal.....</b>	<b>749</b>
	<b>Annex.....</b>	<b>751</b>
<b>A</b>	<b>Reference Information for Remote Control.....</b>	<b>751</b>
<b>A.1</b>	<b>Additional Basics on Remote Control.....</b>	<b>751</b>
A.1.1	Messages.....	751
A.1.2	LAN Interface Messages.....	752
A.1.3	SCPI Command Structure.....	752
A.1.3.1	Syntax for Common Commands.....	753
A.1.3.2	Syntax for Device-Specific Commands.....	753
	Long and short form.....	753
	Numeric Suffixes.....	754
	Optional Mnemonics.....	754
A.1.3.3	SCPI Parameters.....	755
	Numeric Values.....	755
	Special Numeric Values.....	756
	Boolean Parameters.....	756
	Text Parameters.....	757
	Character Strings.....	757
	Block Data.....	757
A.1.3.4	Overview of Syntax Elements.....	757
A.1.3.5	Structure of a Command Line.....	759
A.1.3.6	Responses to Queries.....	759
A.1.4	Command Sequence and Synchronization.....	760
A.1.4.1	Preventing Overlapping Execution.....	760
A.1.4.2	Examples to Command Sequence and Synchronization.....	762
A.1.5	Status Reporting System.....	763
A.1.5.1	Hierarchy of the Status Registers.....	764
A.1.5.2	Structure of a SCPI Status Register.....	765
A.1.5.3	Status Byte (STB) and Service Request Enable Register (SRE).....	767
A.1.5.4	Event Status Register (ESR) and Event Status Enable Register (ESE).....	768

A.1.5.5	Questionable Status Register (STATus:QUEStionable).....	769
A.1.5.6	Operation Status Register (STATus:OPERation).....	769
A.1.5.7	Application of the Status Reporting System.....	769
	Service Request.....	770
	Serial Poll.....	770
	Query of an instrument status.....	770
	Error Queue.....	771
A.1.5.8	Reset Values of the Status Reporting System.....	771
A.1.6	General Programming Recommendations.....	772
<b>A.2</b>	<b>Telnet program examples.....</b>	<b>772</b>
<b>A.3</b>	<b>Extensions for User Files.....</b>	<b>777</b>
<b>B</b>	<b>Hardware Interfaces.....</b>	<b>779</b>
<b>B.1</b>	<b>GPIB-Bus Interface.....</b>	<b>779</b>
<b>C</b>	<b>Morse Code Settings.....</b>	<b>781</b>
	<b>Glossary: List of the Often Used Terms and Abbreviations.....</b>	<b>782</b>
	<b>List of Commands.....</b>	<b>786</b>
	<b>Index.....</b>	<b>802</b>



# 1 Preface

The R&S SMA100B is a new high-performance signal generator developed to meet demanding customer requirements. Offering excellent signal characteristic and straightforward and intuitive operation, the signal generator makes signal generation fast and easy.

## 1.1 Key Features

Outstanding key features of the R&S SMA100B are:

- Frequency range from 8 kHz to up to 20 GHz (overrange 72 GHz)
- Excellent signal quality
- Excellent single sideband (SSB) phase noise
- Nearly no wideband noise
- Very high output power
- Low harmonics
- Unique pulse train generation
- High-stability reference oscillator
- Intuitive operation via touchscreen with the tile diagram as key element

For more information, see data sheet.

## 1.2 About this Manual

This user manual describes general instrument functions, the manual operation of the instrument and remote control.

The main focus of this manual is on the signal generation capabilities of the instrument and the tasks required to achieve them. The following topics are included:

- **Welcome to the R&S SMA100B**  
Introduction to and getting familiar with the instrument, including introduction to the signal generation principles.
- **Getting Started**  
Information that you have received as a printed book together with your instrument
- **Configuration of the RF Signal**  
Descriptions of the individual operation modes, including configuration settings and task descriptions
- **File and Data Management**  
Description of general functions to handle data files and work with the file system of the instrument
- **System and General Instrument Configuration**  
Description of the general instrument settings and functions

- **Network and Remote Control Operation**  
Information on setting up the instrument in a network and operating it remotely.
- **Remote Commands**  
Remote commands required to configure and perform measurements in a remote environment, sorted by tasks.  
Remote commands required to set up the environment and to perform common tasks on the instrument, sorted by tasks.  
Programming examples demonstrate the use of many commands and can usually be executed directly for test purposes.
- **Maintenance**  
Information on tasks required to maintain the operability of the instrument
- **Troubleshooting and Error Messages**  
Hints and tips on how to handle errors
- **Appendix**  
Extensive reference information on remote control, hardware interfaces, etc.
- **Glossary**  
List of often used terms and abbreviations
- **List of Commands**  
Alphabetical list of all remote commands described in the manual
- **Index**

### Contents and scope

This help system describes the full functionality of an R&S SMA100B. Depending on your model and the installed options, some of the functions may not be available on your instrument.

### Notes on screenshots

When describing the functions of the product, we use sample screenshots. These screenshots are meant to illustrate as much as possible of the provided functions and possible interdependencies between parameters. The shown values may not represent realistic usage scenarios.

The screenshots usually show a fully equipped product, that is: with all options installed. Thus, some functions shown in the screenshots may not be available in your particular product configuration.

## 1.3 Documentation Overview

This section provides an overview of the R&S SMA100B user documentation. Unless specified otherwise, you find the documents on the R&S SMA100B product page at:

[www.rohde-schwarz.com/manual/sma100b](http://www.rohde-schwarz.com/manual/sma100b)



### 1.3.1 Getting Started Manual

Introduces the R&S SMA100B and describes how to set up and start working with the product. Includes basic operations, typical measurement examples, and general information, e.g. safety instructions, etc. A printed version is delivered with the instrument.

### 1.3.2 User Manuals and Help

Contains the description of all instrument modes and functions. It also provides an introduction to remote control, a complete description of the remote control commands with programming examples, and information on maintenance, instrument interfaces and error messages. Includes the contents of the getting started manual.

The contents of the user manuals are available as help in the R&S SMA100B. The help offers quick, context-sensitive access to the complete information.

All user manuals are also available for download or for immediate display on the Internet.

### 1.3.3 Service Manual

Describes the performance test for checking compliance with rated specifications, firmware update, troubleshooting, adjustments, installing options and maintenance.

The service manual is available for registered users on the global Rohde & Schwarz information system (GLORIS):

<https://gloris.rohde-schwarz.com>

### 1.3.4 Instrument Security Procedures

Deals with security issues when working with the R&S SMA100B in secure areas. It is available for download on the Internet.

### 1.3.5 Printed Safety Instructions

Provides safety information in many languages. The printed document is delivered with the product.

### 1.3.6 Data Sheets and Brochures

The data sheet contains the technical specifications of the R&S SMA100B. It also lists the options and their order numbers and optional accessories.

The brochure provides an overview of the instrument and deals with the specific characteristics.

See [www.rohde-schwarz.com/brochure-datasheet/sma100b](http://www.rohde-schwarz.com/brochure-datasheet/sma100b)

### 1.3.7 Release Notes and Open Source Acknowledgment (OSA)

The release notes list new features, improvements and known issues of the current firmware version, and describe the firmware installation.

The open-source acknowledgment document provides verbatim license texts of the used open source software.

See [www.rohde-schwarz.com/firmware/sma100b](http://www.rohde-schwarz.com/firmware/sma100b)

### 1.3.8 Application Notes, Application Cards, White Papers, etc.

These documents deal with special applications or background information on particular topics.

See [www.rohde-schwarz.com/application/sma100b](http://www.rohde-schwarz.com/application/sma100b)

## 2 Safety and Regulatory Information

The product documentation helps you use the product safely and efficiently. Follow the instructions provided here and in the [Chapter 2.1, "Safety Instructions"](#), on page 23.

### Intended use

The product is intended for the development, production and verification of electronic components and devices in industrial, administrative, and laboratory environments. Use the product only for its designated purpose. Observe the operating conditions and performance limits stated in the data sheet.

### Where do I find safety information?

Safety information is part of the product documentation. It warns you of potential dangers and gives instructions on how to prevent personal injury or damage caused by dangerous situations. Safety information is provided as follows:

- In [Chapter 2.1, "Safety Instructions"](#), on page 23. The same information is provided in many languages as printed "Safety Instructions". The printed "Safety Instructions" are delivered with the product.
- Throughout the documentation, safety instructions are provided when you need to take care during setup or operation.

### 2.1 Safety Instructions

Products from the Rohde & Schwarz group of companies are manufactured according to the highest technical standards. To use the products safely, follow the instructions provided here and in the product documentation. Keep the product documentation nearby and offer it to other users.

Use the product only for its intended use and within its performance limits. Intended use and limits are described in the product documentation such as the data sheet, manuals and the printed safety instructions. If you are unsure about the appropriate use, contact Rohde & Schwarz customer service.

Using the product requires specialists or specially trained personnel. These users also need sound knowledge of at least one of the languages in which the user interfaces and the product documentation are available.

If any part of the product is damaged or broken, stop using the product. Never open the casing of the product. Only service personnel authorized by Rohde & Schwarz are allowed to repair the product. Contact Rohde & Schwarz customer service at <http://www.customersupport.rohde-schwarz.com>.

#### Lifting and carrying the product

The product is heavy. Do not move or carry the product by yourself. A single person can only carry a maximum of 18 kg safely depending on age, gender and physical condition. Look up the maximum weight in the data sheet. Use the product handles to

move or carry the product. Do not lift by the accessories mounted on the product. Accessories are not designed to carry the weight of the product.

To move the product safely, you can use lifting or transporting equipment such as lift trucks and forklifts. Follow the instructions provided by the equipment manufacturer.

### **Choosing the operating site**

Only use the product indoors. The product casing is not waterproof. Water that enters can electrically connect the casing with live parts, which can lead to electric shock, serious personal injury or death if you touch the casing. If Rohde & Schwarz provides a carrying bag designed for your product, you can use the product outdoors.

Unless otherwise specified, you can operate the product up to an altitude of 2000 m above sea level. The product is suitable for pollution degree 2 environments where nonconductive contamination can occur. For more information on environmental conditions such as ambient temperature and humidity, see the data sheet.

### **Setting up the product**

Always place the product on a stable, flat and level surface with the bottom of the product facing down. If the product is designed for different positions, secure the product so that it cannot fall over.

If the product has foldable feet, always fold the feet completely in or out to ensure stability. The feet can collapse if they are not folded out completely or if the product is moved without lifting it. The foldable feet are designed to carry the weight of the product, but not an extra load.

If stacking is possible, keep in mind that a stack of products can fall over and cause injury.

If you mount products in a rack, ensure that the rack has sufficient load capacity and stability. Observe the specifications of the rack manufacturer. Always install the products from the bottom shelf to the top shelf so that the rack stands securely. Secure the product so that it cannot fall off the rack.

### **Connecting to power**

The product is an overvoltage category II product and has to be connected to a fixed installation used to supply energy-consuming equipment such as household appliances and similar loads. Be aware that electrically powered products have risks, such as electric shock, fire, personal injury or even death.

Take the following measures for your safety:

- Before switching on the product, ensure that the voltage and frequency indicated on the product match the available power source. If the power adapter does not adjust automatically, set the correct value and check the rating of the fuse.
- If a product has an exchangeable fuse, its type and characteristics are indicated next to the fuse holder. Before changing the fuse, switch off the instrument and disconnect it from the power source. How to change the fuse is described in the product documentation.





- Only use the power cable delivered with the product. It complies with country-specific safety requirements. Only insert the plug into an outlet with protective conductor terminal.
- Only use intact cables and route them carefully so that they cannot be damaged. Check the power cables regularly to ensure that they are undamaged. Also ensure that nobody can trip over loose cables.
- If the product needs an external power supply, use the power supply that is delivered with the product or that is recommended in the product documentation or a power supply that conforms to the country-specific regulations.
- Only connect the product to a power source with a fuse protection of maximum 20 A.
- Ensure that you can disconnect the product from the power source at any time. Pull the power plug to disconnect the product. The power plug must be easily accessible. If the product is integrated into a system that does not meet these requirements, provide an easily accessible circuit breaker at the system level.

### Cleaning the product

Use a dry, lint-free cloth to clean the product. When cleaning, keep in mind that the casing is not waterproof. Do not use liquid cleaning agents.

### Meaning of safety labels

Safety labels on the product warn against potential hazards.

	<p>Potential hazard</p> <p>Read the product documentation to avoid personal injury or product damage.</p>
	<p>Heavy product</p> <p>Be careful when lifting, moving or carrying the product. Carrying the product requires at least two people or transport equipment.</p>
	<p>Electrical hazard</p> <p>Indicates live parts. Risk of electric shock, fire, personal injury or even death.</p>
	<p>Hot surface</p> <p>Do not touch. Risk of skin burns. Risk of fire.</p>
	<p>Protective conductor terminal</p> <p>Connect this terminal to a grounded external conductor or to protective ground. This protects you against electric shock should an electric problem occur.</p>

## 2.2 Labels on R&S SMA100B

Labels on the casing inform about:

- Personal safety, see ["Connecting to power"](#) on page 24.
- Product and environment safety, see [Table 2-1](#).

- Identification of the product, see the serial number on the [rear panel](#).

**Table 2-1: Labels regarding R&S SMA100B and environment safety**

	Labeling in line with EN 50419 for disposal of electrical and electronic equipment after the product has come to the end of its service life. For more information, see <a href="#">Chapter 17.4, "Disposal"</a> , on page 749.
---	---

## 2.3 Korea Certification Class A



이 기기는 업무용(A급) 전자파 적합기기로서 판매자 또는 사용자는 이 점을 주의하시기 바라며, 가정외의 지역에서 사용하는 것을 목적으로 합니다.

## 3 Getting Started

### 3.1 Preparing for Use

This chapter describes the basic steps to be taken when setting up the product for the first time.

#### 3.1.1 Lifting and Carrying

See also ["Lifting and carrying the product"](#) on page 23.

- ▶ **WARNING!** The R&S SMA100B can be heavy, e.g., if fully equipped. Use a lifting equipment, see also ["Lifting and carrying the product"](#) on page 23.  
Use the carrying handles at the side for lifting and carrying the R&S SMA100B. The handles at the front are only for pushing and pulling the instrument when mounting in a rack, see [Chapter 3.1.4.2, "Mounting the R&S SMA100B in a Rack"](#), on page 29.

#### 3.1.2 Unpacking and Checking

1. Unpack the R&S SMA100B carefully.
2. Retain the original packing material. Use it to protect the control elements and connectors when transporting or shipping the R&S SMA100B later.  
See also [Chapter 16, "Transporting"](#), on page 738.
3. Using the delivery notes, check the equipment for completeness.
4. Check the equipment for damage.

If the delivery is incomplete or equipment is damaged, contact Rohde & Schwarz.

#### 3.1.3 Choosing the Operating Site

Specific operating conditions ensure accurate measurements and avoid damage to the product and connected devices. For information on environmental conditions such as ambient temperature and humidity, see the data sheet.

See also ["Choosing the operating site"](#) on page 24.

### Electromagnetic compatibility classes

The electromagnetic compatibility (EMC) class indicates where you can operate the product. The EMC class of the product is given in the data sheet under "General data".

- Class B equipment is suitable for use in:
  - Residential environments
  - Environments that are directly connected to a low-voltage supply network that supplies residential buildings
- Class A equipment is intended for use in industrial environments. It can cause radio disturbances in residential environments due to possible conducted and radiated disturbances. It is therefore not suitable for class B environments. If class A equipment causes radio disturbances, take appropriate measures to eliminate them.

## 3.1.4 Setting Up the R&S SMA100B

See also:

- ["Setting up the product"](#) on page 24.
- ["Intended use"](#) on page 23.

### 3.1.4.1 Placing the R&S SMA100B on a Bench Top

#### To place the product on a bench top

1. Place the product on a stable, flat and level surface. Ensure that the surface can support the weight of the product. For information on the weight, see the data sheet.
2. **CAUTION!** Foldable feet can collapse. See ["Setting up the product"](#) on page 24. Always fold the feet completely in or out. With folded-out feet, do not place anything on top or underneath the product.
3. **WARNING!** A stack of products can fall over and cause injury. Never stack more than three products on top of each other. Instead, mount them in a rack.

Stack as follows:

- It is best if all products have the same dimensions (width and length).
- The overall load on the lowest product must not exceed 500 N.
- With smaller products on top of the lowest product, the overall load on the lowest product must not exceed 250 N.



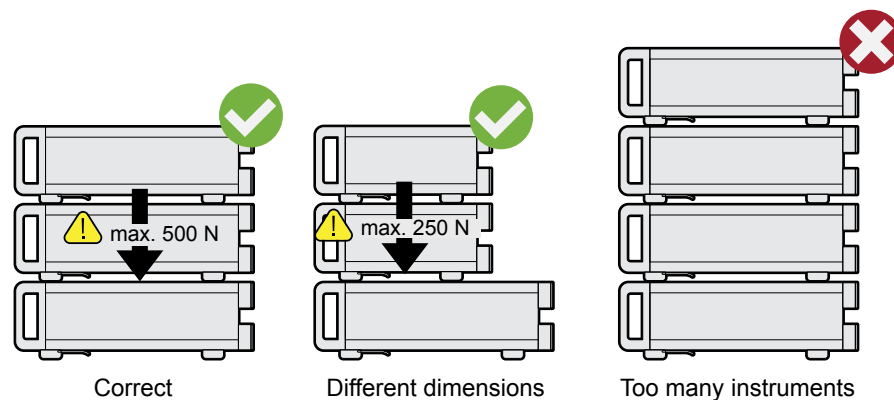

4. **NOTICE!** Overheating can damage the product.

Prevent overheating as follows:

- Keep a minimum distance of 10 cm between the fan openings of the product and any object in the vicinity.
- Do not place the product next to heat-generating equipment such as radiators or other products.

#### 3.1.4.2 Mounting the R&S SMA100B in a Rack

##### To prepare the rack

1. Observe the requirements and instructions in "[Setting up the product](#)" on page 24.
2. **NOTICE!** Insufficient airflow can cause overheating and damage the product. Design and implement an efficient ventilation concept for the rack.

##### To mount the R&S SMA100B in a rack

1. Use an adapter kit that fits the dimensions of the R&S SMA100B to prepare the instrument for rack mounting. For information on the dimensions, see data sheet.
  - a) Order the rack adapter kit designed for the R&S SMA100B. For the order number, see data sheet.
  - b) Mount the adapter kit. Follow the assembly instructions provided with the adapter kit.
2. **WARNING!** The R&S SMA100B can be heavy, e.g., if fully equipped. Use a lifting equipment, see also "[Lifting and carrying the product](#)" on page 23. Lift the R&S SMA100B to shelf height.
3. Grab the handles at the front and push the R&S SMA100B onto the shelf until the rack brackets fit closely to the rack.
4. Tighten all screws at the rack brackets with a tightening torque of 1.2 Nm to secure the R&S SMA100B at the rack.

**To unmount the R&S SMA100B from a rack**

1. Loosen the screws at the rack brackets.
2. **WARNING!** The R&S SMA100B can be heavy, e.g., if fully equipped. Use a lifting equipment, see also "[Lifting and carrying the product](#)" on page 23.  
Bring the lifting equipment to shelf height.
3. Remove the R&S SMA100B from the rack.
4. If placing the R&S SMA100B on a bench top again, unmount the adapter kit from the R&S SMA100B. Follow the instructions provided with the adapter kit.

### 3.1.5 Important Aspects for Test Setup

**Cable selection and electromagnetic interference (EMI)**

Electromagnetic interference (EMI) can affect the measurement results.

To suppress electromagnetic radiation during operation:

- Use high-quality shielded cables, especially for the following connector types:
  - BNC  
Double-shielded BNC cables.
  - USB  
Double-shielded USB cables.  
How to: [Chapter 3.1.8, "Connecting USB Devices"](#), on page 32.  
See also [Chapter 15.6, "Measuring USB cable quality"](#), on page 730.
  - LAN  
At least CAT6 STP cables.  
How to: [Chapter 3.1.7, "Connecting to LAN"](#), on page 31
- Always terminate open cable ends.
- Ensure that connected external devices comply with EMC regulations.

**Signal input and output levels**

Information on signal levels is provided in the data sheet. Keep the signal levels within the specified ranges to avoid damage to the R&S SMA100B and connected devices.

**Preventing electrostatic discharge (ESD)**

Electrostatic discharge is most likely to occur when you connect or disconnect a DUT.

- ▶ **NOTICE!** Risk of electrostatic discharge. Electrostatic discharge can damage the electronic components of the product and the device under test (DUT).  
Ground yourself to prevent electrostatic discharge damage:
  - a) Use a wrist strap and cord to connect yourself to ground.
  - b) Use a conductive floor mat and heel strap combination.

### 3.1.6 Connecting to Power

For safety information, see "[Connecting to power](#)" on page 24.

1. Plug the AC power cable into the AC power connector on the rear panel of the instrument. Only use the AC power cable delivered with the R&S SMA100B.
2. Plug the AC power cable into a power outlet with ground contact.  
The required ratings are listed next to the AC power connector and in the data sheet.

### 3.1.7 Connecting to LAN

#### Network environment

The product is designed to operate at local workplaces or in secured local area networks (LAN). Products accessible from the internet constitute a potential security risk. For example, attackers can misuse or damage the product.

To reduce security risks, install the latest firmware and always keep secure remote connections, if possible. E.g., use `https` instead of `http`.

We highly recommend that you work closely with your IT department or system administrator to ensure compliance with your company policies, when connecting the product to your company's network.

#### To connect to LAN

The connector is located on the [rear panel](#).

- ▶ Connect the LAN socket via an RJ-45 cable to the LAN.

By default, the R&S SMA100B is configured to use DHCP (dynamic host configuration protocol) and no static IP address is configured.

If switched on and connected to the LAN, the R&S SMA100B displays the address information on the screen.

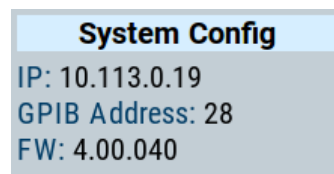

*Figure 3-1: IP address indication on the screen (example)*

See [Chapter 13.6, "Connecting the Instrument to the Network \(LAN\)"](#), on page 399

### 3.1.8 Connecting USB Devices

USB connectors are located on the [front panel](#) and [rear panel](#). You can connect or disconnect all USB devices from the R&S SMA100B during operation.

#### To connect USB storage devices

USB storage devices, such as memory sticks, allow easy data transfer from/to the R&S SMA100B. You can also use them for firmware updates.

- ▶ Connect the USB storage device to any of the USB connectors.

#### To connect USB devices with external power supply

1. **NOTICE!** Connected devices with external power supply can feed back current into the 5 V power supply of the USB interface and thus damage the R&S SMA100B.

Ensure that there is no connection between the positive pole of the power supply and the +5 V power pin of the USB interface (VBUS).

2. Connect the USB storage device to any of the USB connectors.

#### To connect a keyboard

- ▶ Connect the keyboard to any of the USB connectors.

When connected, the R&S SMA100B detects the keyboard automatically. A detected keyboard has the default layout English – US.

#### To connect a mouse

- ▶ Connect the mouse to any of the USB connectors.

When connected, the R&S SMA100B detects the mouse automatically.

#### To connect power sensors

You can connect power sensors of the R&S NRP families to any of the USB connectors.

See [Chapter 8.4, "Using Power Sensors"](#), on page 228.

### 3.1.9 Connecting to RF

The connector is located on the [front panel](#).

If you have the instrument equipped with an option for rear panel connectors, the RF output connector is on the rear panel.

#### To prepare for connecting to "RF"

1. **NOTICE!** Damaged or not clean connections can lead to RF insertion loss and mismatch, and even premature wear of the connectors.

Before connecting to the port, inspect the RF connector visually to check that it is clean, undamaged and mechanically compatible.

See the application note [1MA99](#) for information on how to handle and maintain the RF port, to minimize measurement deviations and ensure its longevity.

2. **NOTICE!** Risk of instrument damage. Excessive reverse power or DC voltage at the RF connector can damage the instrument.  
Make sure that the values do not exceed the reverse power and DC limits as given in the data sheet.
3. If the R&S SMA100B is switched on, deactivate the RF output, before connecting an RF cable to the RF connector.  
In the home screen, select the block "Level" > "RF ON > Off".
4. Use a high-quality RF cable that matches the RF connector type.  
See "[Cable selection and electromagnetic interference \(EMI\)](#)" on page 30.

#### To connect to screwable connectors

1. Use a high-quality cable that matches the connector type.  
See "[Cable selection and electromagnetic interference \(EMI\)](#)" on page 30.
2. **NOTICE!** Risk of instrument damage and connector damage. Excessive tightening can damage the cables and the connectors. However, if you do not tighten the connectors enough, the measurement results can be inaccurate.  
To connect the cable with the connector, proceed as follows:
  - a) Carefully align the connector of the cable and the connector along a common axis.
  - b) Mate the connectors along the common axis until the male pin of the inner connector engages with the female socket of the outer connector.
  - c) Turn the nut of the outer connector until the connectors are firmly coupled.
  - d) Torque the nut to the specified limit using a calibrated torque wrench. Hold the opposite connector part stationary with a spanner.  
For torque limits of the most relevant connector types, see [Table 3-1](#).
3. Torque the nut to the specified limit using a calibrated torque wrench. Hold the opposite connector part stationary with a spanner.

For more information, see chapter "Handling" of the application note [1MA99](#).

If your instrument is equipped with a test port adapter, see the application note [1MA100](#).

The connector types listed in this table represent the common connectors provided by Rohde & Schwarz. It is considered as general information and therefore can contain connector types that do not apply to your instrument.

See [Chapter 3.2.1.11, "RF 50 Ω"](#), on page 42.

Table 3-1: Connector types and torque limits

Type	Torque limit		Nut opening	
	lb-Inch	Nm	Inch	mm
N	13.3	1.5	3/4	20
SMA	5	0.56	5/16	8
3.5 mm	8	0.9	5/16	8
2.92 mm	8	0.9	5/16	8
2.4 mm	8	0.9	5/16	8
1.85 mm	8	0.9	5/16	8
1.0 mm	3	0.34	0.236	6

**To prevent RF output switch-off**

- ▶ **NOTICE!** If you set a too high output level without a load connected to the instrument, the reverse power can exceed a limit forcing the R&S SMA100B to switch off the RF output.

Connect a load with sufficient return loss as given in the data sheet.

**3.1.10 Connecting to Ref In/Ref Out**

The connector is located on the [rear panel](#).

**To connect to "Ref In"/"Ref Out" (reference < 1 GHz)**

For connection, the R&S SMA100B provides BNC connectors.

- ▶ To connect the cable with the "Ref In"/"Ref Out" connector, proceed as follows:
  - a) Carefully align the connector of the cable and the "Ref In"/"Ref Out" connector along a common axis.
  - b) Mate the connectors along the common axis until the male pin of the connector of the cable engages with the female socket of the "Ref In"/"Ref Out" connector.

**To connect to Ref In/Ref Out (reference = 1 GHz)**

For connection, the R&S SMA100B provides SMA connectors.

1. Use a high-quality cable that matches the connector type.  
See "[Cable selection and electromagnetic interference \(EMI\)](#)" on page 30.
2. **NOTICE!** Risk of instrument damage and connector damage. Excessive tightening can damage the cables and the connectors. However, if you do not tighten the connectors enough, the measurement results can be inaccurate.

To connect the cable with the connector, proceed as follows:

- a) Carefully align the connector of the cable and the connector along a common axis.
- b) Mate the connectors along the common axis until the male pin of the inner connector engages with the female socket of the outer connector.
- c) Turn the nut of the outer connector until the connectors are firmly coupled.
- d) Torque the nut to the specified limit using a calibrated torque wrench. Hold the opposite connector part stationary with a spanner.

For torque limits of the most relevant connector types, see [Table 3-1](#).

3. Torque the nut to the specified limit using a calibrated torque wrench. Hold the opposite connector part stationary with a spanner.

For more information, see chapter "Handling" of the application note [1MA99](#).

**Table 3-2: Connector types and torque limits**

Type	Torque limit		Nut opening	
	lb-Inch	Nm	Inch	mm
N	13.3	1.5	3/4	20
SMA	5	0.56	5/16	8
3.5 mm	8	0.9	5/16	8
2.92 mm	8	0.9	5/16	8
2.4 mm	8	0.9	5/16	8
1.85 mm	8	0.9	5/16	8
1.0 mm	3	0.34	0.236	6

### 3.1.11 Switching On or Off

The following table provides an overview of power states, LEDs and power switch positions.

**Table 3-3: Overview of power states**

State	LED	Position of power switch
Off	● gray	[0]
Standby	● orange	[1]
Ready	● green	[1]

#### To switch on the R&S SMA100B

The R&S SMA100B is off but connected to power. See [Chapter 3.1.6, "Connecting to Power"](#), on page 31.

1. Set the switch on the power supply to position [1].  
The switch is located on the [rear panel](#).  
The LED of the [On/Standby] key is orange.

2. Press the [On/Standby] key.  
Key and LED are located on the [front panel](#).  
The LED changes to green. The R&S SMA100B boots.

When starting for the first time, the R&S SMA100B starts with the default settings. When restarting the instrument, the settings depend on the instrument configuration before shut-down.

See [Chapter 11.4, "Saving and Recalling Instrument Settings"](#), on page 311.

When the instrument is switched on, it automatically monitors main functions. You can query erroneous functions. In addition to automatic monitoring, you can perform maintenance tasks.

See:

- [Chapter 15.4, "Querying Error Messages"](#), on page 727
- [Chapter 17.3, "Performing Maintenance Tasks"](#), on page 739

### To shut down the product

The product is in the ready state.

- ▶ Press the On/Standby key.

The operating system shuts down. The LED changes to orange.

In the standby state, the power switch circuits are active. To deactivate them, disconnect the instrument from the power supply.

### To disconnect from power

The R&S SMA100B is in the standby state.

1. **NOTICE!** Risk of data loss. If you disconnect the product from power when it is in the ready state, you can lose settings and data. Shut it down first.  
Set the toggle switch on the power supply to position [0].  
The LED of the [On/Standby] key is switched off.
2. Disconnect the R&S SMA100B from the power source.

## 3.2 Instrument Tour

The following topics help you get familiar with the instrument and perform the first steps:

- [Front Panel Tour](#)
- [Rear Panel Tour](#)

This section explains the control elements and the connectors of the R&S SMA100B with the aid of the front and rear views. For specifications of the interfaces, refer to the data sheet.



The meanings of the labels on the R&S SMA100B are described in [Chapter 2.2, "Labels on R&S SMA100B"](#), on page 25.

### 3.2.1 Front Panel Tour

This section provides an overview of the control elements at the front panel of the R&S SMA100B. Most of the connectors are at the rear panel and are described in [Chapter 3.2.2, "Rear Panel Tour"](#), on page 44.



**Figure 3-2: Front panel view of the R&S SMA100B RF Signal Generator with height unit 2HU (option R&S SMAB-B92)**

- 1 = Touchscreen
- 2 = Utility keys
- 3 = [On/Standby]
- 4 = Function keys
- 5 = Keypad
- 6 = Navigation controls
- 7 = Display keys
- 8 = USB connector
- 9 = SD card slot
- 10 = Sensor connector
- 11 = RF output connector

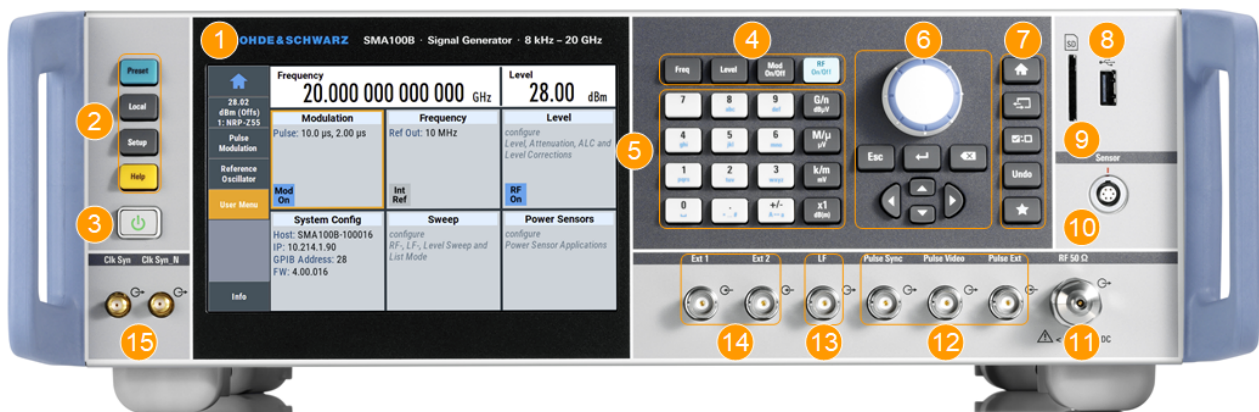

**Figure 3-3: Front panel view of the R&S SMA100B RF Signal Generator with height unit 3HU (option R&S SMAB-B93)**

- 1 = Touchscreen
- 2 = Utility keys
- 3 = [On/Standby]
- 4 = Function keys



**Table 3-4: Utility keys**

Utility Key	Assigned functions
[Preset]	Sets the instrument to a defined state
[Local]	Switches from remote control to local (manual) control
[Setup]	Accesses the general instrument settings
[Help]	Displays context-sensitive help text

### 3.2.1.3 On/Standby

The [On/Standby] key switches the instrument from the standby to the ready state or vice versa.

The LED above the [On/Standby] key indicates the instrument state, see [Chapter 3.1.11, "Switching On or Off"](#), on page 35.

### 3.2.1.4 Function Keys

Function keys provide access to the most common generator settings and functions. You can find a detailed description of the corresponding functions in the user manual.

**Table 3-5: Function keys**

Function key	Assigned functions
[Freq]	Activates frequency entry.
[Level]	Activates level entry.
[Mod on/off]	Switches the modulation on and off.
[RF on/off]	Switches the RF output on and off.

### 3.2.1.5 Keypad

The keypad enables you to enter alphanumeric parameters, including the corresponding units. It contains the following keys:

**Table 3-6: Keys on the keypad**

Type of key	Description
Alphanumeric keys	Enter numbers and (special) characters in edit dialog boxes.
Decimal point	Inserts a decimal point "." at the cursor position.
Sign key	Changes the sign of a numeric parameter. In the case of an alphanumeric parameter, inserts a "-" at the cursor position.
Unit keys (G/n dB $\mu$ V, M/ $\mu$ $\mu$ V, k/m mV and x1 dB(m))	These keys add the selected unit to the entered numeric value and complete the entry.  In the case of level entries (e.g. in dB) or dimensionless values, all units have the value "1" as multiplying factor. Thus, they have the same function as an [Enter] key.

### 3.2.1.6 Navigation Controls

The navigation controls include a rotary knob, navigation keys, and the display keys. They allow you to navigate within the display or within dialog boxes.

#### Rotary Knob

The rotary knob has several functions:

- Increments (clockwise direction) or decrements (counterclockwise direction) the instrument parameter at a defined step width in the case of a numeric entry.
- Moves the selection, e.g. to a function block in the block diagram
- Shifts the selection bar within focused areas (e.g. lists).
- Acts like the [Enter] key, when it is pressed.
- Opens a context-sensitive menu, when it is pressed and held.

#### Editing Keys

Editing keys enable you to confirm an entry, delete individual characters, or exit the current operation.

*Table 3-7: Editing keys*

Type of key	Description
[Esc] key	<p>Closes all kinds of dialog boxes, if the edit mode is not active. Quits the edit mode, if the edit mode is active. In dialog boxes that contain a "Cancel" button it activates that button.</p> <p>For "Edit" dialog boxes the following mechanism is used:</p> <ul style="list-style-type: none"> <li>• If data entry has been started, it retains the original value and closes the dialog box.</li> <li>• If data entry has not been started or has been completed, it closes the dialog box.</li> </ul>
[Enter] key	<p>Has the same effect as pressing the rotary knob</p> <ul style="list-style-type: none"> <li>• Concludes the entry of dimensionless entries. The new value is accepted.</li> <li>• With other entries, this key can be used instead of the default unit key.</li> <li>• In a dialog box, selects the default or focused element.</li> <li>• Calls the next dialog level.</li> <li>• Confirms and closes open input windows.</li> </ul>
[Backspace] key	Deletes the character to the left of the cursor in editing mode.

#### Navigation Keys

As an alternative to the rotary knob or the touchscreen, you can use the navigation keys to navigate through dialog boxes, diagrams, or tables.

**Table 3-8: Navigation keys**

Type of key	Description
[Up/Down] Key	The [Up] and the [Down] key does the following: <ul style="list-style-type: none"> <li>• In a numeric edit dialog box, increase or decrease the instrument parameter.</li> <li>• In a list, scroll forward and backward through the list entries.</li> <li>• In a table, move the selection bar vertically.</li> <li>• In windows or dialog boxes with vertical scrollbar, move the scrollbar.</li> </ul>
[Left/Right] Key	The [Left] and the [Right] key does the following: <ul style="list-style-type: none"> <li>• In an alphanumeric edit dialog box, move the cursor.</li> <li>• In a list, scroll forward and backward through the list entries.</li> <li>• In a table, move the selection bar horizontally.</li> <li>• In windows or dialog boxes with horizontal scrollbar, move the scrollbar.</li> </ul>

### 3.2.1.7 Display Keys

The display keys arrange different windows on the display.

**Table 3-9: Display keys**

Display key	Assigned functions
[Home]	Returns to the initial feature screen.
[Next window]	Toggles between the entry fields in the taskbar.
[On/Off]	<ul style="list-style-type: none"> <li>• Switches highlighted elements or a function block on and off.</li> <li>• Switches between two or more settings, e.g. items of selection lists. At the end of a list, the cursor is set on the first entry again.</li> </ul>
[Undo]	Reverts the last operation.
[★ (User)]	Adds a parameter to the user menu for quick access.

### 3.2.1.8 USB Connector

Female USB type A connector, to connect devices like a keyboard, a mouse, a memory stick, or the R&S NRP-Z3/Z4 cable for the R&S NRP power sensors.

How to: [Chapter 3.1.8, "Connecting USB Devices"](#), on page 32

### 3.2.1.9 SD card slot

Option: R&S SMAB-B85

Slot for removable mass storage.

To prevent from unauthorized removal, the SD card holder includes wholes that provide the opportunity of sealing the SD card. We recommend that you seal the SD card crosswise.

### 3.2.1.10 Sensor

Connector for R&S NRP sensors.

A power sensor is connected to the R&S SMA100B by inserting the male connector. To disconnect, pull the connector by its sleeve. You cannot disconnect the sensor simply by pulling at the cable or the rear part of the connector.

The R&S SMA100B supports the use of R&S NRP power sensors in various ways including the use as a power viewer.



The female connector allows the mechanical connection of 6-pole and 8-pole male connectors.

It mates with the interface cables R&S NRP-ZK8 and R&S NRP-ZK6, used for connecting R&S NRPxx power sensors, and also with the six-pole push-pull plugs of the R&S NRP-Zxx series.

However, the signal pair of the common time base clock assigned to the two pins in the center of the male connectors is not available. These pins are used by Rohde & Schwarz power meters to synchronize several power sensors.

Further information on connecting and using power sensors, see [Chapter 8.4.1, "Connecting R&S NRP Power Sensors to the R&S SMA100B"](#), on page 229, [Chapter 8.4.4, "NRP-Z Power Analysis"](#), on page 240, [Chapter 8.4.2, "NRP Sensor Mapping"](#), on page 230, [Chapter 8.4.4, "NRP-Z Power Analysis"](#), on page 240 and [Chapter 8.3, "User Correction"](#), on page 216.

### 3.2.1.11 RF 50 Ω

Output of the RF signal.

The connector type depends on the installed frequency option.

**Table 3-10: RF connector types of the frequency options**

Installed RF frequency option	Connector type	Frequency range
R&S SMAB-B103	N female	$f_{\max} \leq 6$ GHz
R&S SMAB-B106		
R&S SMAB-B112	PC 2.92 mm female Instrument equipped with interchangeable PC 2.92 mm test port adapter.	$f_{\max} \leq 40$ GHz
R&S SMAB-B120		
R&S SMAB-B131		
R&S SMAB-B140(N)		
R&S SMAB-B150(N)	PC 1.85 mm female Instrument equipped with PC 1.85 mm interchangeable female/female wear and tear adapter.	$f_{\max} \leq 67$ GHz
R&S SMAB-B167(N)		



The PC 1.85 mm male connector for up to 67 GHz comes with a protective 1.85 mm female adapter to prevent the sensitive connector from damage.

It is available as a spare part, and can be replaced if damaged. Contact your Rohde & Schwarz support center or [www.customersupport.rohdeschwarz.com](http://www.customersupport.rohdeschwarz.com) for information.

How to: [Chapter 3.1.9, "Connecting to RF"](#), on page 32

### 3.2.1.12 Pulse Signal Connectors

#### **Pulse Sync**

Output signal for synchronizing the pulse generator signal. The synchronization signal is generated at the beginning of each pulse. For double-pulse generation, the synchronization signal is generated at the beginning of the first pulse.

#### **Pulse Video**

Output of the internal pulse generator signal or the looped through pulse signal from Pulse Ext connector (video signal).

See [Chapter 5.4.1, "Pulse Modulation"](#), on page 83.

#### **Pulse Ext**

Input for an external pulse modulation signal or an external trigger/gate signal for the pulse generator.

### 3.2.1.13 LF Modulation Connectors

#### **LF**

Output for internal LF generator signal.

See the data sheet and in the user manual, section [Chapter 5, "Analog Modulations"](#), on page 80.

#### **Ext**

Input for external analog modulation signals.

See [Chapter 5, "Analog Modulations"](#), on page 80.

### 3.2.1.14 Clock Synthesizer Connectors

#### **Clk Syn/Clk Syn N**

Connectors for output of the clock synthesizer signal, or the inverted signal.



### 3.2.2 Rear Panel Tour

This section provides an overview of the connectors at the rear panel of the instrument. For technical data of the connectors, refer to the data sheet.

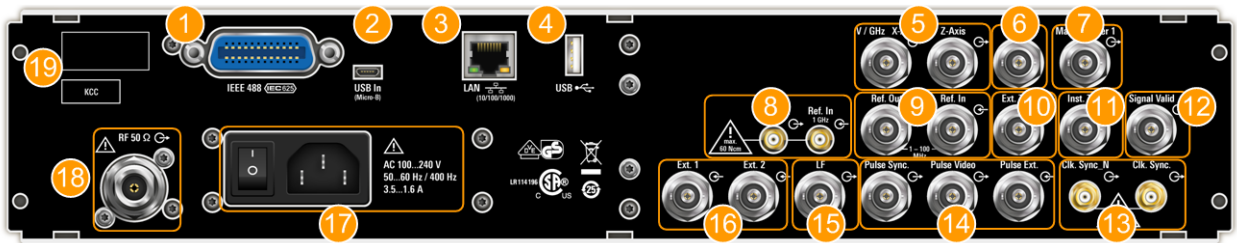

**Figure 3-5: Rear panel view of the R&S SMA100B RF Signal Generator with height unit 2HU (option R&S SMAB-B92)**

- 1 = IEC 625/IEEE 488 connector
- 2 = USB In connector (type micro-B)
- 3 = LAN connector
- 4 = USB connector (type A)
- 5 = V/GHz X-Axis and Z-Axis output connectors (BNC)
- 6 = Stop input and output connector (BNC)
- 7 = Marker User1 output connector (BNC)
- 8 = Ref In 1GHz and Ref Out 1GHz connectors (SMA)
- 9 = Ref In and Ref Out connectors (BNC)
- 10 = EFC input connector (BNC)
- 11 = Inst Trig input connector (BNC)
- 12 = Signal Valid output connector (BNC)
- 13 = Clk Syn and Clk Syn N output connectors (SMA)
- 14 = Pulse Sync, Pulse Video and Pulse Ext connectors (BNC)
- 15 = LF output connector (BNC)
- 16 = Ext 1/2 input connectors (BNC)
- 17 = AC power supply connection and main power switch
- 18 = RF output connector
- 19 = Serial number (six digits in the string 1419.8888.02-<serial number>-<checksum>)

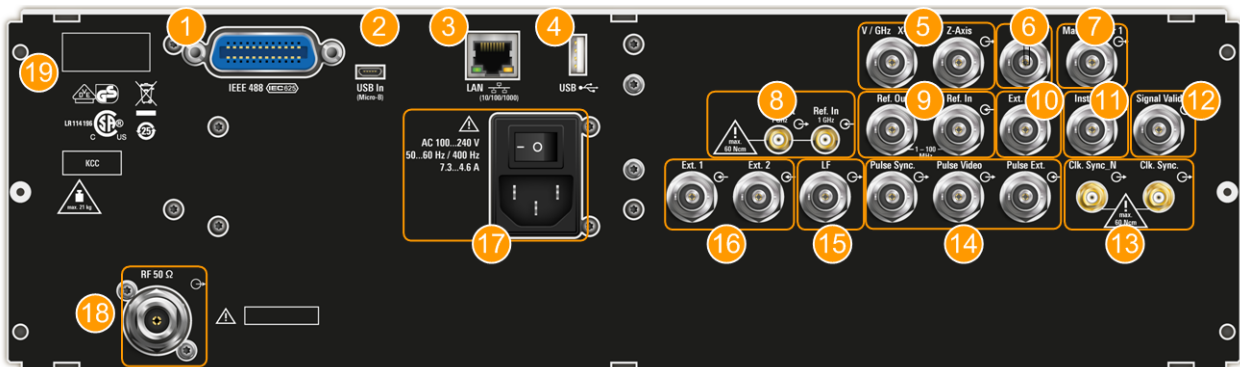

**Figure 3-6: Rear panel view of the R&S SMA100B RF Signal Generator with height unit 3HU (option R&S SMAB-B93)**

- 1 = IEC 625/IEEE 488 connector
- 2 = USB In connector (type micro-B)
- 3 = LAN connector
- 4 = USB connector (type A)
- 5 = V/GHz X-Axis and Z-Axis output connectors (BNC)



- 6 = Stop input and output connector (BNC)
- 7 = Marker User1 output connector (BNC)
- 8 = Ref In 1GHz and Ref Out 1GHz connectors (SMA)
- 9 = Ref In and Ref Out connectors (BNC)
- 10 = EFC input connector (BNC)
- 11 = Inst Trig input connector (BNC)
- 12 = Signal Valid output connector (BNC)
- 13 = Clk Syn and Clk Syn N output connectors (SMA)
- 14 = Pulse Sync, Pulse Video and Pulse Ext connectors (BNC)
- 15 = LF output connector (BNC)
- 16 = Ext 1/2 input connectors (BNC)
- 17 = AC power supply connection and main power switch
- 18 = RF output connector
- 19 = Serial number (six digits in the string 1419.8888.02-<serial number>-<checksum>)

### 3.2.2.1 Connectors

#### IEC 625/IEEE 488

Option: R&S SMAB-B86

General purpose interface bus (GPIB) interface for remote control of the instrument. The interface is in compliance with the standards IEC 625, IEEE 488 and SCPI.

Use this interface to connect a computer for remote control of the R&S SMA100B. To set up the connection, use high-quality shielded cables. See "[Cable selection and electromagnetic interference \(EMI\)](#)" on page 30.

See also [Chapter B.1, "GPIB-Bus Interface"](#), on page 779 and [Chapter 13, "Network Operation and Remote Control"](#), on page 371.

#### USB/USB In

- Female USB type A connector, to connect devices like a keyboard, a mouse, a memory stick, or the R&S NRP-Z3/Z4 cable for the R&S NRP power sensors
- Option: R&S SMAB-B86  
Female USB In connector (USB type B), for example for remote control.

How to: [Chapter 3.1.8, "Connecting USB Devices"](#), on page 32

#### LAN

RJ-45 connector to connect the R&S SMA100B to a LAN for remote control, remote operation, and data transfer.

How to: [Chapter 3.1.7, "Connecting to LAN"](#), on page 31

#### V/GHz X-Axis

Output of a voltage ramp:

- "V / GHz": the voltage is proportional to the frequency.
- "X-Axis": output of a voltage ramp for the X deflection of an oscilloscope or an XY recorder.

#### Z-Axis

Output of a voltage pulse, e.g. for the combined blanking and marker generation of network analyzers.

**Stop**

Input and output for stopping the sweep in all modes.

This connector is bidirectional. Used as:

- "Input": enables you to stop a sweep triggered by an external network analyzer.
- "Output": enables the R&S SMA100B to stop the sweep of an external network analyzer.

**Marker User1**

Output signal for marker or trigger signal.

**Signal Valid**

Output signal that marks the valid signal times (valid level and frequency) for all analog modulations.

Alternatively, you can use this connector to synchronize pulse signals by activating the "Pulse Sync" in the dialog [Chapter 5.4.4, "Pulse Generator"](#), on page 97.

**Inst Trig**

BNC connector for input of external trigger signals. The signals trigger sweeps and list mode.

See [Chapter 7.1, "Signal Generation and Triggering in the Sweep and List Modes"](#), on page 171.

**EFC**

BNC connector for input of an EFC (external frequency control) signal for electronic tuning of the internal reference frequency.

See [Chapter 9, "Reference Oscillator"](#), on page 288.

**Ref In/Ref Out**

Input/output for external reference signal.

BNC connectors for reference signals from 1 MHz to 100 MHz.

SMA connectors for 1 GHz reference signals.

How to: [Chapter 3.1.10, "Connecting to Ref In/Ref Out"](#), on page 34

**Clk Syn/Clk Syn N**

Connectors for output of the clock synthesizer signal, or the inverted signal.

**Pulse Ext**

Input for an external pulse modulation signal or an external trigger/gate signal for the pulse generator.

**Pulse Video**

Output of the internal pulse generator signal or the looped through pulse signal from Pulse Ext connector (video signal).

See [Chapter 5.4.1, "Pulse Modulation"](#), on page 83.

**Pulse Sync**

Output signal for synchronizing the pulse generator signal. The synchronization signal is generated at the beginning of each pulse. For double-pulse generation, the synchronization signal is generated at the beginning of the first pulse.

**LF**

Output for internal LF generator signal.

See the data sheet and in the user manual, section [Chapter 5, "Analog Modulations"](#), on page 80.

**Ext 1/2**

Inputs for external analog modulation signal.

See [Chapter 5, "Analog Modulations"](#), on page 80.

**AC power supply connector and switch**

Mains power switch for performing the following tasks:

- Connecting the internal power supply to the power source
- Disconnecting the internal power supply from the power source

How to: [Chapter 3.1.6, "Connecting to Power"](#), on page 31.

**RF**

Rear panel connector for the RF signal. This connector is for use of the instrument in a 19" rack.

How to:

- [Chapter 3.1.4.2, "Mounting the R&S SMA100B in a Rack"](#), on page 29
- [Chapter 3.1.9, "Connecting to RF"](#), on page 32

## 3.3 Trying Out the Instrument

This chapter introduces the first steps with the R&S SMA100B. It shows how to operate and configure the instrument using simple examples. The complete description of the functionality and its usage is given in the R&S SMA100B user manual. Basic instrument operation is described in [Chapter 3.4, "Instrument Control"](#), on page 55.

**Prerequisites**

The instrument is set up, connected to the power supply, and started up as described in [Chapter 3.1, "Preparing for Use"](#), on page 27.

The first signal generation tasks explain how to generate an unmodulated signal, to configure the RF signal output, and how you can vary the RF frequency and level in sweep mode.

The instrument is manually operated via the touchscreen. Try out the following:

- [Generating an Unmodulated Carrier](#)..... 48
- [Generating an RF Frequency Sweep Signal](#)..... 50
- [Saving and Recalling Settings](#)..... 52

### 3.3.1 Generating an Unmodulated Carrier

We start to generate a simple unmodulated signal. In this example, the R&S SMA100B can be in its minimal configuration.

1. On the R&S SMA100B front panel, press the [Preset] key to set a defined initial instrument state.
2. Set the frequency:
  - a) In the "Status Bar", tap the "Frequency" field.
  - b) On the on-screen keypad, enter "6" and press the "GHz" key.

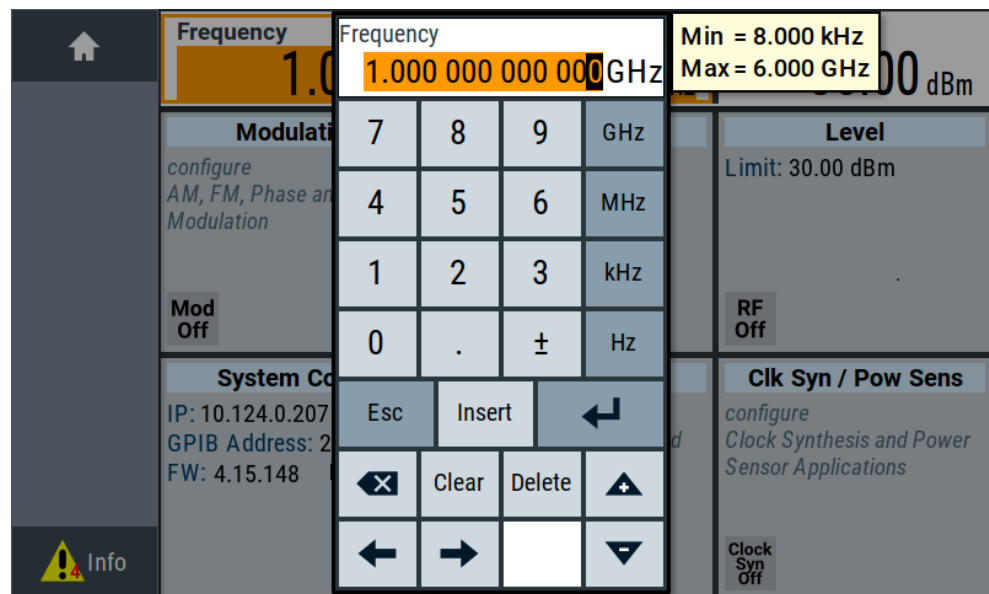

The on-screen key pad closes and the frequency value is displayed.

3. To set the signal level, tap the "Level" field and enter the level in the same way.
4. To activate RF signal output, select "Level" > "RF On" in the tile diagram.

<b>Frequency</b> 6.000 000 000 000 GHz		<b>Level</b> -25.00 dBm
<b>Modulation</b> configure AM, FM, Phase and Pulse Modulation Mod Off	<b>Frequency</b> Ref Out: 10 MHz Int Ref	<b>Level</b> Limit: 30.00 dBm Level <input checked="" type="checkbox"/> RF ON Level... Attenuator... Automatic Level Control...
<b>System Config</b> IP: 10.124.0.207 GPIB Address: 28 FW: 4.15.148	<b>Sweep</b> configure RF-, LF-, Level Sweep and List Mode	

The blue colored "RF On" icon indicates that the RF output is activated.

The R&S SMA100B provides the 6 GHz signal at the RF A connector at the front panel.

<b>Frequency</b> 6.000 000 000 000 GHz		<b>Level</b> -25.00 dBm
<b>Modulation</b> configure AM, FM, Phase and Pulse Modulation Mod Off	<b>Frequency</b> Ref Out: 10 MHz Int Ref	<b>Level</b> Limit: 30.00 dBm RF On
<b>System Config</b> IP: 10.124.0.207 GPIB Address: 28 FW: 4.15.148	<b>Sweep</b> configure RF-, LF-, Level Sweep and List Mode	<b>Clk Syn / Pow Sens</b> configure Clock Synthesis and Power Sensor Applications Clock Syn Off

Figure 3-7: Generating an unmodulated signal

### Alternative ways to access the instrument functions

To fulfill the same task, you can also use the front panel keys or the setting parameters provided in the frequency and level dialogs.

### Try out the settings dialogs

1. In the "Frequency" tile, select "Frequency...".
  - a) In the "RF Frequency" tab, tap the "Frequency" field.
  - b) Set the frequency via the on-screen keypad.
2. Access the "RF Level" dialog via the "Level" tile.
  - a) In the "RF Level" tab, select "Amplitude".
  - b) Set the amplitude (level) via the on-screen keypad.
3. Select "RF State > On" to activate the RF signal generation.

See [Chapter 4, "RF Signal Configuration"](#), on page 66.

### Try out the front panel keys

- ▶ Use the [Freq], [Level], and [RF on/off] key on the front panel.



Connect RF of the R&S SMA100B to a signal analyzer, for example R&S®FSW, to display the generated signal.

For the required settings of the signal analyzer, refer to its user manual or its online help.

## 3.3.2 Generating an RF Frequency Sweep Signal

The "Sweep" operating mode allows you to generate an RF signal with periodically varying frequencies or amplitudes.

This example deals with an RF signal with varying frequency and constant level. To configure the sweep, you need to determine a defined start and end frequency with constant time intervals between the frequency steps.

The sweep function does not require specific options.

1. On the front panel, press the [Preset] key to set a defined initial instrument state.
2. Set the signal output level, if required, e.g. set "Level > -25 dBm".
3. In the tile diagram, select "Sweep" > "Frequency Sweep".
4. In the "General" tab:

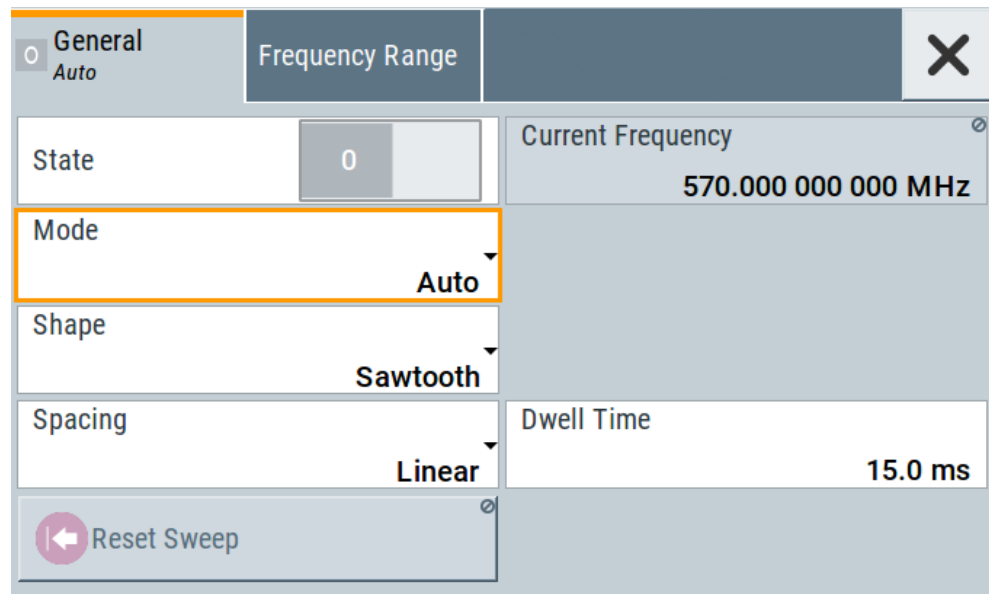

- a) Select "Mode > Auto" to run the sweep continuously.
  - b) Select "Shape > Sawtooth" to set the waveform shape of the sweep signal.
  - c) Select "Spacing > Linear", to determine the calculation method for the frequency shift of a step.
  - d) Set "Dwell Time > 15.0 ms", to determine the time interval of the sweep steps.
5. Select the "Frequency Range" tab.

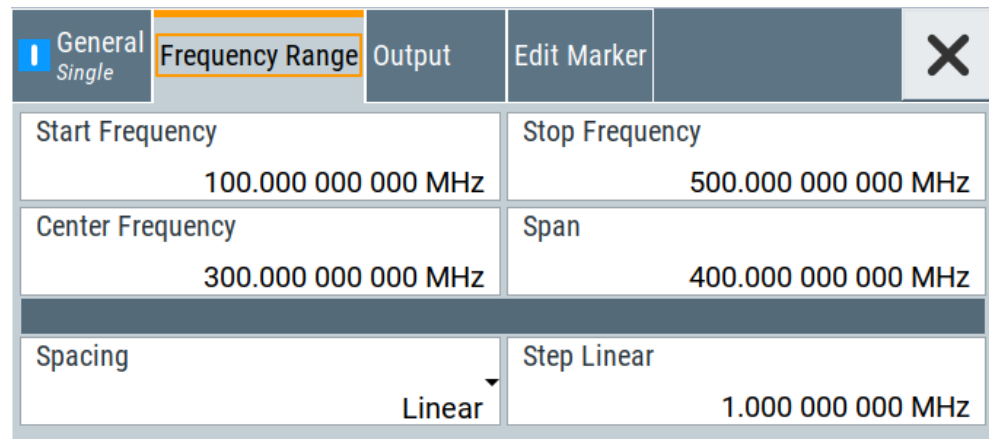

- a) Set "Start Freq > 200 MHz" and "Stop Freq > 600 MHz" to determine the frequency sweep range.
  - b) Set the step width "Step Lin > 10.0 MHz" to determine the width for a frequency step.
6. In the "General" tab, activate the frequency sweep with "State > On".
  7. Close the sweep dialog.  
(Alternatively, tap the "Home" button to minimize the dialog. The R&S SMA100B indicates the "Sweep" dialog as active dialog in the task bar.)

8. To activate the RF signal output, select "Level" > "RF On".

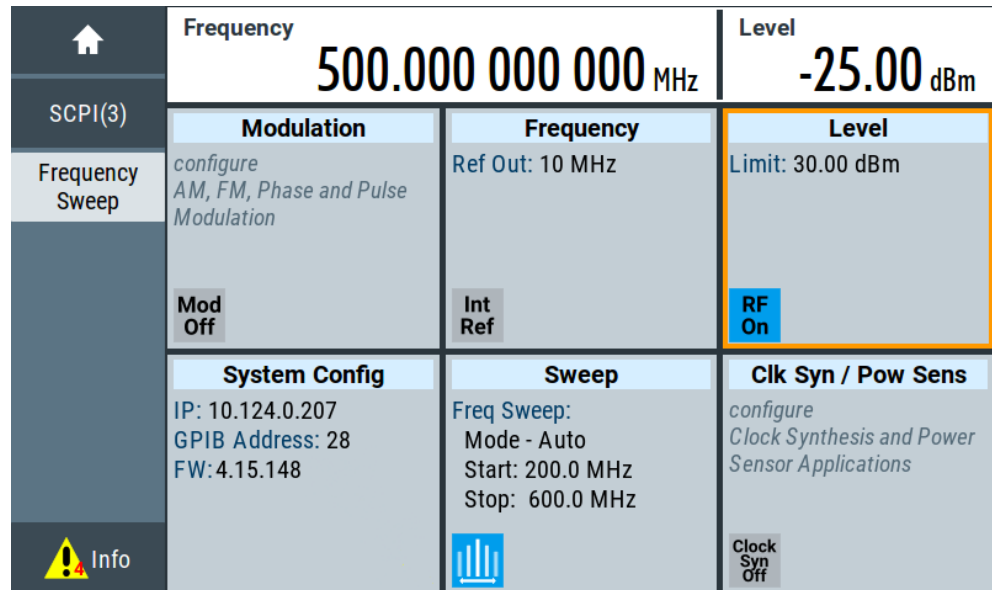

Figure 3-8: Generating a frequency sweep signal

The frequency field in the status bar indicates the continuously changing frequency, i.e. the running sweep.

### 3.3.3 Saving and Recalling Settings

To restore the results of our measurements later, we save the instrument settings in a file.

#### To save the instrument settings in a file

We assume, a test configuration as described in [Chapter 3.3.2, "Generating an RF Frequency Sweep Signal"](#), on page 50.

1. Press the [Setup] key on the front panel.
2. In the "Setup" menu, select "Settings > Save/Recall".
3. In the "Save/Recall" dialog, select "Operation Mode > Save".



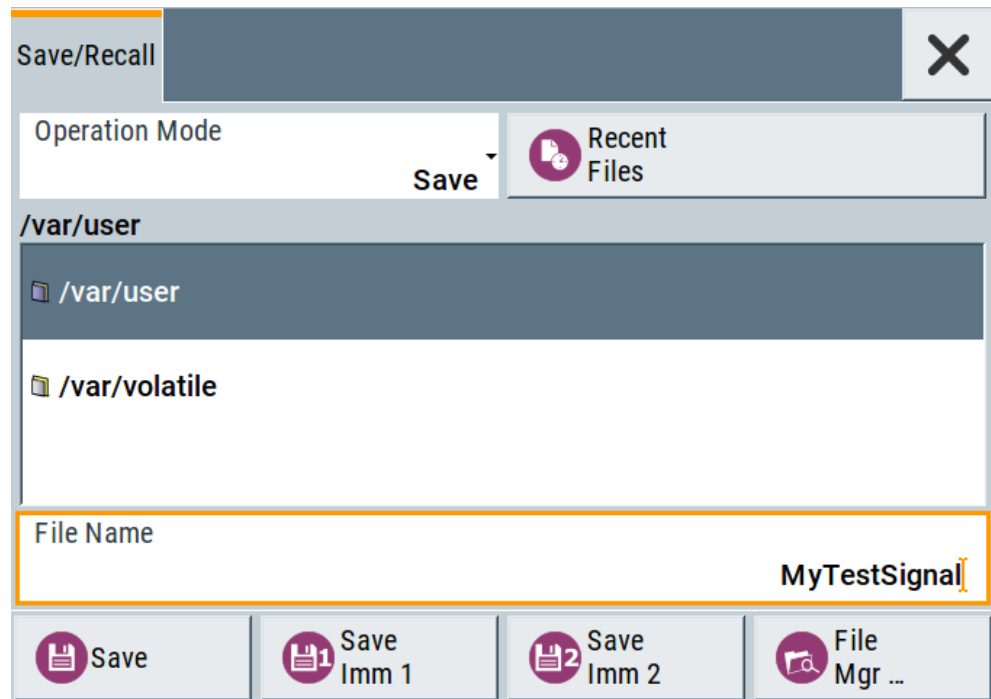

4. Tap the "Filename", use the on-screen keyboard, and enter *MyTestSignal*.
5. Tap the "Save" button.

The file `MyTestSignal.savrcltxt` is stored in the default directory `/var/user/`.

#### To load saved instrument settings

You can restore the settings to the instrument at any time using the settings file.

1. Press the [Preset] button to restore the default instrument settings so you can check that the stored user settings are restored afterwards.
2. Press the [Setup] key on the front panel.
3. In the "Setup" menu, select "Settings > Save/Recall".
4. In the "Save/Recall" dialog, select "Operation Mode > Recall".  
Navigate to the directory the file is saved in and select the `MyTestSignal` file.

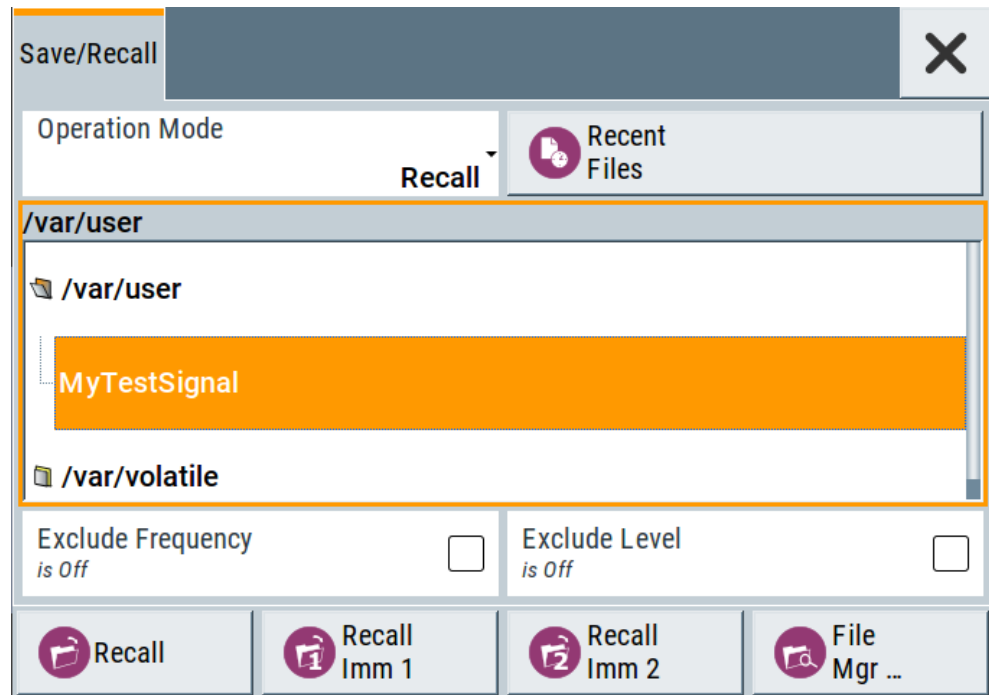

5. Tap the "Recall" button.

All instrument settings are restored and the display resembles [Chapter 3.3.2, "Generating an RF Frequency Sweep Signal"](#), on page 50, which shows the instrument display right before the settings were saved.





#### How to display all parameters with values different to their preset values



When you load a file to your instrument, you do not have enough information on the changed settings. In such case, it is useful to visualize all parameters that have been changed from their default state.

Try out the following:

- Touch and hold a spot in the tile diagram for at least 1 second to access the context-sensitive menu.
- Select "Mark All Parameters Changed from Preset".

 **Mark All Parameters Changed from Preset**
 **Start SCPI Recording**
 **Undo**
 **Redo**
 **Help**
 **Key Emulation**

- All changed parameters are highlighted.

	<b>Frequency</b> <span style="font-size: 2em;">410.000 000 000 MHz</span>		<b>Level</b> <span style="font-size: 2em;">-25.00 dBm</span>
	<b>SCPI(3)</b> <b>Frequency Sweep</b>	<b>Modulation</b> <i>configure</i> <i>AM, FM, Phase and Pulse Modulation</i>	<b>Frequency</b> Ref Out: 10 MHz
	<b>Mod Off</b>	<b>Int Ref</b>	<b>RF On</b>
	<b>System Config</b> IP: 10.124.0.207 GPIB Address: 28 FW: 4.15.148	<b>Sweep</b> Freq Sweep: Mode - Auto Start: 200.0 MHz Stop: 600.0 MHz	<b>Clk Syn / Pow Sens</b> <i>configure</i> <i>Clock Synthesis and Power Sensor Applications</i>
 <b>Info</b>			<b>Clock Syn Off</b>

See also [Chapter 11, "File and Data Management"](#), on page 302.

## 3.4 Instrument Control

This chapter provides an overview on how to work with the R&S SMA100B.

It covers the following topics:

• Possible Ways to Operate the Instrument.....	56
• Means of Manual Interaction.....	56
• Understanding the Display Information.....	57
• Accessing the Functionality.....	60
• Entering Data.....	61
• Getting Information and Help.....	62
• Remote Control.....	64
• Remote Operation over VNC.....	65

### 3.4.1 Possible Ways to Operate the Instrument

There are three ways to operate the R&S SMA100B:

- Manual operation:  
Use the touchscreen, hard keys and rotary knob, or an optional mouse and/or keyboard.  
The description under [Chapter 3.4, "Instrument Control"](#), on page 55 shows how to operate the instrument manually.
- Remote control:  
Create programs to automatize repeating settings, tests and measurements. The instrument is connected to a computer running the program.  
This way of operation is described in [Chapter 13, "Network Operation and Remote Control"](#), on page 371.
- Remote operation from a computer:  
Remote monitoring and control of the instrument from a connected computer is based on the common cross-platform technology VNC (Virtual Network Computing). On the remote computer, any standard web browser (supporting Java) or a dedicated VNC client (like Ultr@VNC) can be used. See also [Chapter 3.4.8, "Remote Operation over VNC"](#), on page 65.

### 3.4.2 Means of Manual Interaction

For the manual interaction with the R&S SMA100B, you have several methods that you can use as an alternative to perform a task:

- Touchscreen:  
Touchscreen operation is the most direct way to interact. Almost all control elements and actions on the screen are based on the standard operating system concept. You can tap any user interface element to set parameters in dialog boxes, enter data, scroll within a dialog etc., as if you work with a mouse pointer.  
Tapping the screen works like clicking mouse buttons:
  - Touch quickly = click: Selects a parameter or provokes an action.
  - Touch and hold = right-click: Opens a context-sensitive menu.
  - Touch and swipe = drag: Scrolls through the contents of a display element larger than the screen, e.g. a list or a table.
- Function keys and rotary knob:  
The front panel provides nearly all functions and controls to operate the instrument in the classic way, without touchscreen.

- Optional mouse and/or keyboard:  
These devices work like known from PCs. The navigation keys on the front panel correspond to the keys on the keyboard.

This manual describes the manual interaction with the instrument via the touchscreen. It mentions the alternative methods using the keys on the instrument or the on-screen keypads if it deviates from the standard operating procedures. The usage of the touchscreen and navigation keys is described in [Chapter 3.4.4, "Accessing the Functionality"](#), on page 60.

Throughout the manual, the term "select" refers to any of the described methods, i.e. using a finger on the touchscreen, a mouse pointer in the display, or a key on the instrument or on a keyboard.

### 3.4.3 Understanding the Display Information

The home screen of the R&S SMA100B displays all main settings and generator states, divided into three main operation areas.

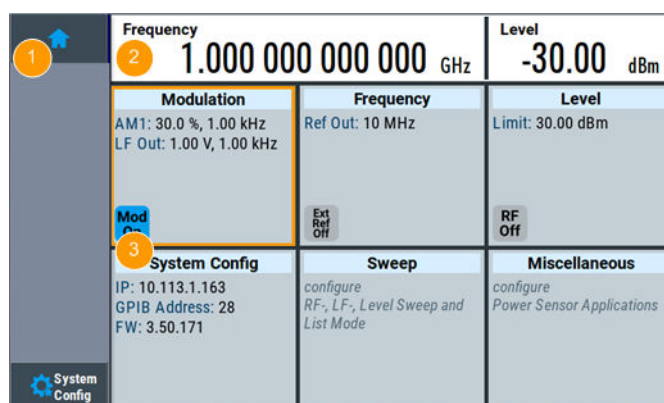

**Figure 3-9: Home screen**

- 1 = Taskbar/softkey bar with "Home" and "System Config" key  
2 = Status bar  
3 = Tile diagram

- [Status Bar](#)..... 57
- [Tile Diagram](#)..... 57
- [Taskbar](#)..... 58
- [Additional Display Characteristics](#)..... 59

#### 3.4.3.1 Status Bar

The status bar at the top of the screen indicates the RF frequency and the level of the output signal provided to the DUT. You can set both parameters directly here.

#### 3.4.3.2 Tile Diagram

The tile diagram is the main entry to the settings of the R&S SMA100B.



Tile	Access to:
"Modulation"	<ul style="list-style-type: none"> <li>Analog and stereo<sup>1)</sup>, and pulse<sup>1)</sup> modulation settings</li> <li>Built in LF generator</li> </ul>
"System Config"	<ul style="list-style-type: none"> <li>"Save/Recall": settings for saving and loading instrument configurations</li> <li>"Remote access": Network and emulation settings.</li> <li>"Setup": general system configuration</li> </ul>
"Sweep"	<ul style="list-style-type: none"> <li>Frequency and level sweeps</li> <li>List mode</li> </ul>
"Frequency"	<ul style="list-style-type: none"> <li>RF frequency and phase</li> <li>Reference frequency</li> </ul>
"Level"	<ul style="list-style-type: none"> <li>RF level</li> <li>Attenuator</li> <li>Automatic level control</li> <li>User correction</li> </ul>
"Clk Syn / Pow Sens"	<ul style="list-style-type: none"> <li>Clock synthesis<sup>1)</sup></li> <li>Power sensors</li> </ul>
<sup>1)</sup> requires additional options	

### 3.4.3.3 Taskbar

The "Taskbar" shows a home and an info button, and assigns a labeled button whenever you open a dialog. If more dialogs are open than the taskbar can display, touch and swipe the taskbar to scroll up and down.

The buttons shown in the following example represent the variants.

**Table 3-11: Example of buttons in the taskbar**

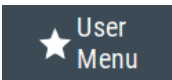
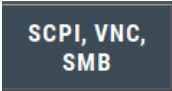
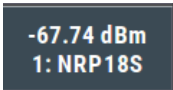
	"Home" button Returns to the home screen.
	"Busy" indicator Indicates a running process.
	"User Menu" Lists parameters that can be defined for quick access.
	Shows the current remote access connections when the instrument is remotely controlled. <b>Tip:</b> An indicator in the "System Config" tile shows the current remote control status.
	R&S NRP power sensors Shows a connected external power sensor. The button displays the current readings when the sensor is active.

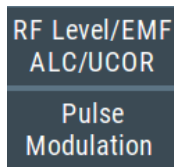

Active dialogs

Indicates the dialog name of each active dialog in a separate button.



"Info" key

Provides access to status and error messages.

**Note:** The warning symbol signifies a permanent error message.

#### 3.4.3.4 Additional Display Characteristics

The following section provides a short insight on the indication of the screen in general, and significant elements that you see under specific operating modes, in dialogs or settings.

- **Appearance of active elements**
  - *Active* elements like On/Off switches, state buttons have a **blue** background.
  - *Selected* elements are framed or highlighted **orange**.
  - *Inactive* elements are **gray**.
- **On-Screen keypads**

As additional means of interacting with the instrument without having to connect an external keyboard, either a numerical or alphanumerical on-screen keypad appears when you activate an entry field (see [Chapter 3.4.5, "Entering Data"](#), on page 61).
- **Info line**

The "Info line" shows brief status information and error messages. It appears when an event generates a message.
- **Key parameters indicated in tab labels**

Most dialogs are divided into tabs with logically grouped parameters. The tab label expresses the content and can also contain status indicators or the set value of a key parameter.
- **Scroll bar handle**

An arrow icon that appears when you touch a scroll bar helps you to scroll in a dialog or list.

If no scrollbar handle appears, you can touch and swipe an element to scroll up and down.
- **Progress indicators**

A busy icon indicates a currently running process. If a process takes some time, a progress bar shows the current state.
- **Context-sensitive menus**

Within the entire screen display, including single parameters, you can access context-sensitive menus that provide some additional functions.

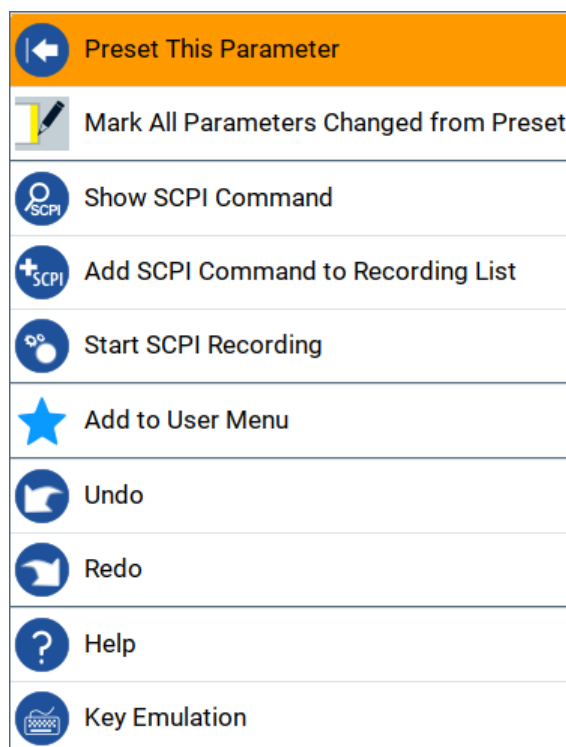

### 3.4.4 Accessing the Functionality

All functionalities are provided in dialog boxes as known from computer programs. You can control the instrument intuitively with the touchscreen. This section provides an overview of the accessing methods.

The instrument's functions and settings can be accessed by selecting one of the following elements:

- System and function keys on the front panel of the instrument
- Taskbar/softkeys on the touchscreen
- Context-sensitive menus for specific elements on the touchscreen, or with the rotary knob (press and hold).
- Elements on the status bar in the touchscreen
- Displayed setting on the touchscreen, that means block diagram and all settings available in dialogs.

#### To open a dialog box

- ▶ Perform one of the following actions:
  - Tap the required tile, and then the menu entry.
  - Tap the minimized view (button) on the taskbar.

Some of the utility keys access a dedicated dialog, too.



**To minimize a dialog box**

1. To return to the home screen, tap the "Home" button.
2. To switch to another dialog, press the [Next Window] button.

**To close a dialog box**

To close a dialog box, you have the same controls as you know from computers or devices with touchscreen.

- ▶ Perform one of the following actions:
  - Tap the "Close" icon in the upper right corner.
  - Press the [Esc] key on the front panel.
  - Drag and drop a minimized dialog from the taskbar to the tile diagram.

**To select an option in a dialog box**

- ▶ Tap the required option.

### 3.4.5 Entering Data

Some parameters have their own key on the front panel.

For data input in dialog boxes, the instrument provides on-screen keypads for entering numeric and alphanumeric values. Thus, you can always set the parameters via the touchscreen, the front panel, or an external keyboard.

**Correcting an entry**

1. Using the arrow keys, move the cursor to the right of the entry you want to delete.
2. Press the [Backspace] key.
3. Deletes the entry to the left of the cursor.
4. Enter your correction.

**Completing the entry**

- ▶ Press the [Enter] key or the rotary knob.

**Aborting the entry**

- ▶ Press the [Esc] key.  
The dialog box closes without changing the settings.

### 3.4.5.1 Entering Numeric Parameters

#### To enter values with the on-screen keypad

For numeric settings, the instrument displays the numeric keypad. The units specified correspond to the units of the parameter.

1. Enter the numeric value.
2. Tap the unit button to complete the entry.  
The unit is added to the entry.
3. If the parameter does not require a unit, confirm the entered value by pressing "Enter".

#### To enter values by using the front panel controls

1. Change the currently used parameter value by using the rotary knob or the [Up/Down] keys.
2. If the parameter does not require a unit, confirm the entered value by pressing the [Enter] key or any of the unit keys.  
The instrument highlights the editing line to confirm the entry.

If you edit numeric data in tables, the entry field must be in edit mode: Press [Enter], or the rotary knob to activate the edit mode.

### 3.4.5.2 Entering Alphanumeric Parameters

If a field requires alphanumeric input, you can use the on-screen keyboard to enter letters and (special) characters.

### 3.4.5.3 Undo and Redo Actions

Accessed via the context-sensitive menus, "Undo" allows you to restore one or more actions on the instrument. Depending on the available memory, the "Undo" steps can restore all actions.

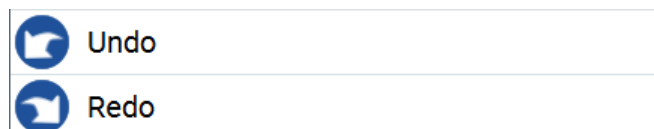

"Redo" restores a previously undone action.

### 3.4.6 Getting Information and Help

In some dialog boxes, graphics are included to explain the way a setting works.

For further information, you can use the following sources:

- Tooltips give the value range of the parameter.
- The context help provides functional description on a setting.
- The general help explains a dialog box, provides instructions, and general information.

### To display context help

- ▶ To access a help topic, perform one of the following:
  - a) Tap and hold the parameter for which you need information and tap "Help" in the context menu.
  - b) Tap the parameter and press the [Help] key.

The "Help" dialog opens. You can browse the help for further information.

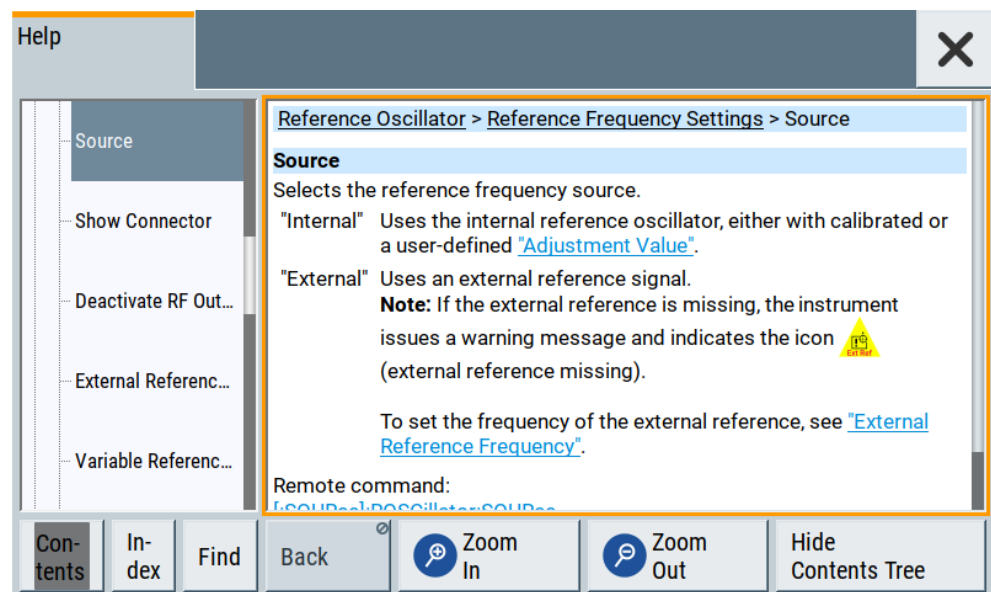

### Contents of the help dialog box

The help dialog box covers two main areas:

- "Contents" - contains a table of help contents
- "Topic" - contains a specific help topic

The help system also provides an "Index" and a "Find" area, and "Zoom" functions that are accessed via the corresponding buttons.

### To open general help

- ▶ Press the yellow [Help] key on the front panel.
 

If a dialog box is opened, the help topic for the current tab is shown. Otherwise the "Contents" page appears.

### Navigating in the table of contents and in the help topics

1. To move through the displayed contents entries, tap on an entry and scroll or use a connected mouse or the [Up/Down] keys.  
Entries with a plus sign contain further entries.
2. To display a help topic, tap on the topic name or double-click the topic name or press the [Enter] key.
3. To follow a cross-reference, tap on the link text.
4. To return to the previous page, select "Back".  
This function scrolls back all steps you have performed before.
5. Use the "scroll bars" to shift the visible section of content shown.
6. To maximize the "Topics" area, tap the "Hide Contents Tree" button to hide the contents tree.

### Using the index

1. Select the "Index" button.
2. Enter the first characters of the topic you are interested in.  
The entries starting with these characters are displayed.
3. Tap on the index entry.  
The corresponding help topic is displayed.

## 3.4.7 Remote Control

In addition to working with the R&S SMA100B interactively, located directly at the instrument, it is also possible to operate and control it from a remote PC.

The R&S SMA100B supports various methods for remote control:

- Connecting the instrument to a LAN (see [Chapter 3.1.7, "Connecting to LAN"](#), on page 31)
- Using the LXI browser interface in a LAN
- Connecting a PC via the IEC-bus (IEEE 488) interface
- Remote control via the USB interface



For remote control over LAN or USB, you can use the R&S VISA (Virtual Instrument Software Architecture) library provided for download at the Rohde & Schwarz website <http://www.rohde-schwarz.com/rsvisa>.

How to configure the remote control interfaces is described in [Chapter 13, "Network Operation and Remote Control"](#), on page 371.

### 3.4.8 Remote Operation over VNC

The VNC is an application which can be used to access and control the instrument from a remote computer through a LAN connection. While the instrument is in operation, the instrument screen contents are displayed on the remote computer, and VNC provides access to all applications, files, and network resources of the instrument. Thus, remote operation of the instrument is possible.



#### Instrument control from a remote computer

To access the basic utility functions of the R&S SMA100B, perform a right mouse click the block diagram and select "Key Emulation".

A key panel to the right of the block diagram gives access to the utility functions provided by the front panel keys.

The VNC is an add-on program, included in operating system Linux/Unix, and available as a free-of-charge download on the internet.

For more information, refer to [Chapter 13.9, "Operating the R&S SMA100B Remotely via VNC"](#), on page 424.

## 4 RF Signal Configuration

The R&S SMA100B signal generator generates RF signals with outstanding spectral purity within the frequency range from 8 kHz up to 20 GHz and with adjustable signal level over a wide range.

In addition to these real-time CW signals, you can generate RF signals from predefined lists and sweep signals that vary according to the frequency or amplitude curves.

You can also apply versatile analog modulation types with definable characteristics.

The variably adjustable output level due to the built-in attenuator, allows you to vary the RF signal level over the full level range. There are different methods to improve signal performance and to optimize the signal quality for the particular application, or to increase the accuracy and reliability of the generated RF signal.

The R&S SMA100B supports R&S NRP power sensors, e.g. to monitor the output level of the generator or to determine the level correction values for user correction lists.

### Signal modes and characteristics

The R&S SMA100B generates unmodulated or analog modulated RF signals. You can output the signal in fixed mode or as a signal having periodically varying frequencies or amplitudes.

**Signal modes** for RF signal generation:

- Unmodulated signal  
Generates an unmodulated continuous wave (CW) of constant frequency and amplitude.  
For information on the signal frequency and level settings and an example on how to configure a simple CW signal, see:
  - [Chapter 4.4, "RF Frequency Settings"](#), on page 71
  - [Chapter 4.5, "RF Level Settings"](#), on page 74
  - [Chapter 3.3.1, "Generating an Unmodulated Carrier"](#), on page 48
- Analog modulated signal  
Modulates the signal with an analog signal and generates amplitude, phase, frequency and pulse modulation.  
See [Chapter 5, "Analog Modulations"](#), on page 80.

The R&S SMA100B allows you to provide the RF signal with constant or varying frequencies and/or amplitudes at the output:

- Constant frequency and level (CW/Fixed mode)  
The RF output signal has the set frequency and level.
- Varying frequency and/or level
  - Sweep mode  
An RF or LF frequency and RF level sweep signal, processed continuously, step-by-step or individually and with selectable trigger modes. You can only run one sweep at a time.
  - List mode

The RF signal is based on a list of predefined frequency and level values pairs and step widths.

See [Chapter 7, "List and Sweep Mode"](#), on page 169.

## 4.1 Activating RF Signal Output

Per default, the RF output signal is deactivated.

### To activate the RF output

1. Configure the RF signal as required.  
Set, for example, the frequency and level values.
2. Activate the RF output in one of the following ways:
  - a) Select "Level > RF ON > On"
  - b) Press the [RF on/off] key at the front panel.
3. In the "Level" tile, observe the color of the "RF On" icon.  
The blue color indicates that the RF output is activated.

<a href="#">RF State/RF ON</a> .....	67
<a href="#">RF output impedance</a> .....	67

### RF State/RF ON

Activates or deactivates the RF output.

Acts as the [RF on/off] key.

Remote command:

`:OUTPut<hw>[:STATe]` on page 475

### RF output impedance

You can query the impedance of the RF output.

Remote command:

`:OUTPut<hw>:IMPedance?` on page 476

## 4.2 How to Set the Frequency and Level

The simplest form of the RF signal is a continuous wave (CW) of constant frequency and amplitude. The RF signal is defined by its frequency, level and phase.

- ▶ Use one of the following:
  - "Status Bar > Frequency and Level"
  - "Frequency panel > Frequency"
  - "Level panel > Level"
  - "Frequency panel > Frequency > Phase"

- On the front panel, press the [Freq] or the [Level] key.

Current frequency and level values are indicated in the "Status bar" so that you can see them at a glance. Values displayed in the status bar and in the "Frequency/Level" dialogs can deviate from each other.

See "RF frequency and level display with a downstream instrument" on page 68.

### RF frequency and level display with a downstream instrument

If your test setup includes a downstream instrument, you can enter the parameter of the downstream instrument in the frequency or level settings dialog of the R&S SMA100B. Examples of downstream instruments are mixers, frequency multipliers, amplifiers or attenuators and of their corresponding major parameters offset, multiplier, amplitude. The R&S SMA100B generates the signal without the downstream parameters, but considers all additional parameters concerning the frequency and level.

Example parameters that affect the frequency and level:

- Frequency offset
- Multiplication factor
- User correction

Any of these cases are indicated by a dedicated icon, displayed in the "Frequency" or "Level" tile, depending on the affected parameter.

Figure 4-1 illustrates the calculation of the "Frequency" and "Level" values, displayed in the status bar.

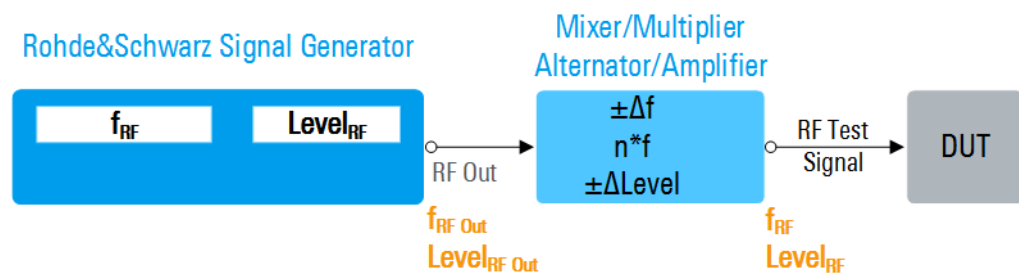

Figure 4-1: Frequency and Level display vs frequency and level at the RF output

$f_{RF}$ , $Level_{RF}$	= Frequency and level ("Status bar > Frequency and Level") at the output of the downstream instrument, see also <a href="#">Calculation of <math>f_{RF}</math> and <math>Level_{RF}</math></a>
$f_{RF\ Out}$ , $Level_{RF\ Out}$	= Frequency and level at the output connector [RF] ("RF > RF Frequency > Frequency" and "RF > RF Level > Amplitude")
$n*f$	= Multiplication factor ("RF > RF Frequency > Multiplier")
$\Delta f$	= Frequency offset ("RF > RF Frequency > Offset")
$\Delta Level$	= Power offset ("RF > RF Level > Offset")

### Calculation of $f_{RF}$ and $Level_{RF}$

- $f_{RF} = n * f_{RF\ Out} + \Delta f$
- $Level_{RF} = Level_{RF\ Out} + \Delta Level$



## 4.3 RF Connector Settings

Access:

1. Select "Frequency" > "RF Connectors".

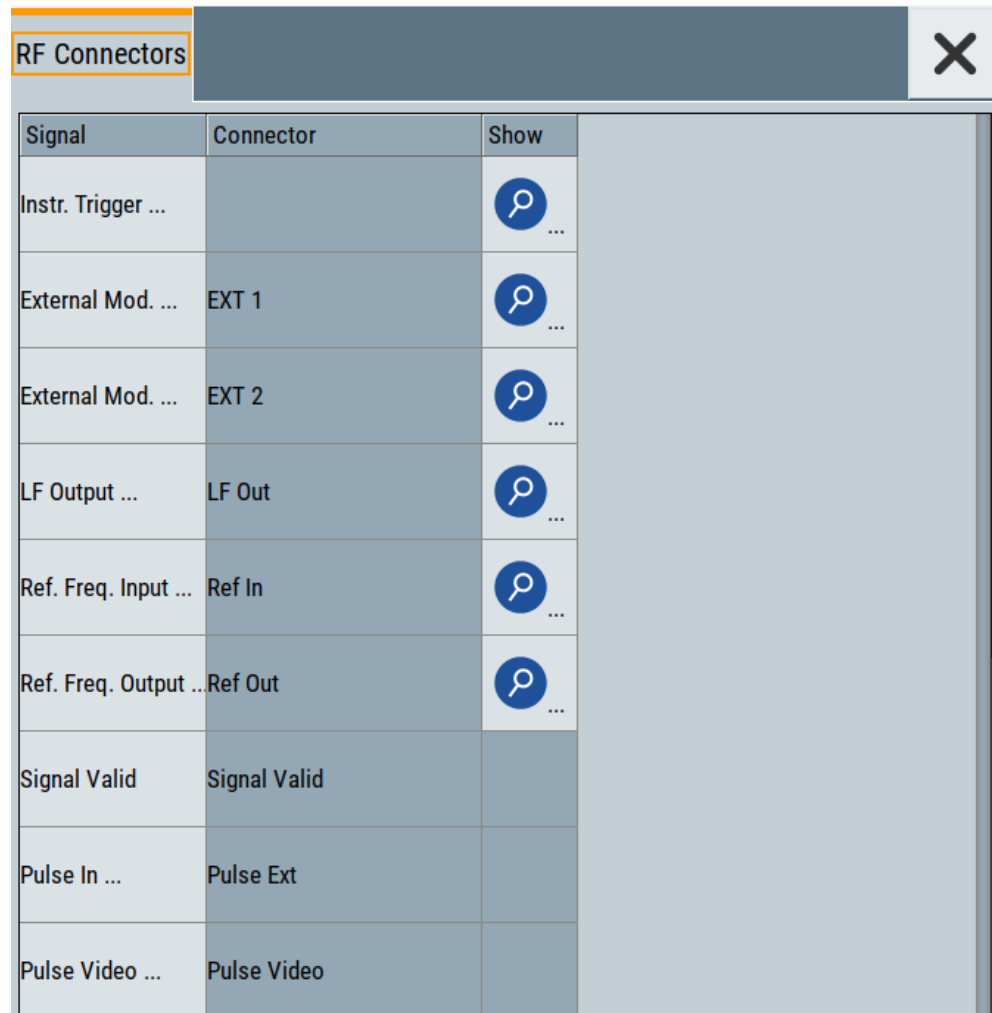

Signal	Connector	Show
Instr. Trigger ...		...
External Mod. ...	EXT 1	...
External Mod. ...	EXT 2	...
LF Output ...	LF Out	...
Ref. Freq. Input ...	Ref In	...
Ref. Freq. Output ...	Ref Out	...
Signal Valid	Signal Valid	
Pulse In ...	Pulse Ext	
Pulse Video ...	Pulse Video	

The "RF Connectors" dialog shows the assignment of the logical signals to the connectors. The connectors displayed depend on the options installed.

2. Select a "Signal" to access the corresponding settings dialog or directly set signal characteristics.
3. Use the built-in [Show Connector](#) function to display the physical location of the selected connector.

The eye icon  in the tab header indicates the panel (front, rear or both) the selected connector is at.

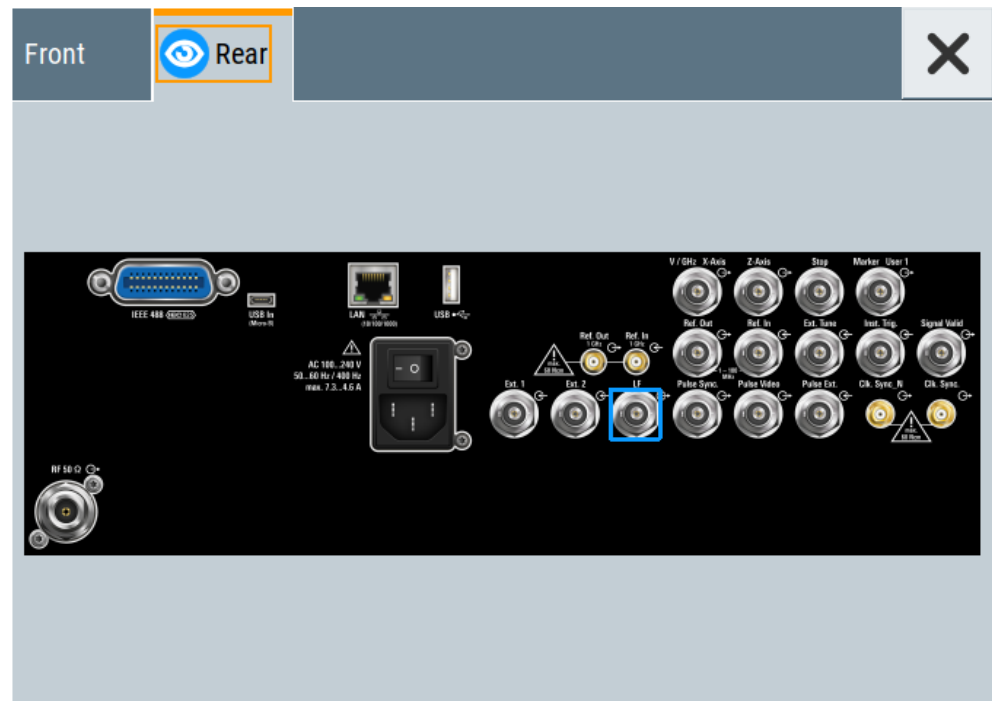

### Settings:

Signal.....	70
Connector.....	71
Show Connector.....	71

### Signal

Displays the signal that is assigned to the connector.

Selecting a signal accesses the settings dialog for configuring the signal, or setting signal characteristics directly.

For additional information on the connectors, see:

- [Chapter 3.2.2.1, "Connectors"](#), on page 45
- ["Signal output"](#) on page 81 for the assignment of the input and output connectors used for analog modulation signals.

"Instr. Trigger"	Input of an external trigger signal for sweep and list modes, see <a href="#">Chapter 7.1, "Signal Generation and Triggering in the Sweep and List Modes"</a> , on page 171.
"External Mod..."	Input of an external modulation signal, see <a href="#">"Signal sources"</a> on page 80.
"LF Output"	Output of the internal LF generator signal, <a href="#">Chapter 5.4.8, "LF Signal Output Settings"</a> , on page 119.
"Ref. Freq. Input"	Input of an external reference signal, see <a href="#">Chapter 9.2, "Reference Frequency Settings"</a> , on page 288 .

**"Ref. Freq. Output"**

Output of the internal reference signal, see [Chapter 9.3, "Reference Output Settings"](#), on page 292 .

**"Signal Valid" / "Signal Valid Neg."**

Automatically generated output signal that identifies a valid signal time (level and frequency) for all analog modulation signals.  
For "Signal Valid Neg." (inverted), the output signal is low during the valid signal time.

**"Pulse In"**

Input of an external pulse signal or input of external trigger/gate signal for the internal pulse generator (see [Chapter 5.4.4, "Pulse Generator"](#), on page 97).

**"Pulse Video"**

Output of the internal pulse generator signal or the looped through "Pulse Ext" pulse signal (video signal), see [Chapter 5.4.1, "Pulse Modulation"](#), on page 83.

**Connector**

Displays the assigned connector.

**Show Connector**

Accesses a dialog that displays the physical location of the selected connector on the front/rear panel of the instrument.

## 4.4 RF Frequency Settings

Access:

1. Select "Frequency" > "RF Frequency".

RF Frequency	Phase		
Frequency	3.000 000 000 000 GHz	Main PLL Bandwidth	Narrow
Offset	10.000 000 000 MHz	Multiplier	2.000
User Variation			
Variation Active <i>is Off</i>	<input type="checkbox"/>	Variation Step	1.000 000 000 MHz

2. Observe the information on the home screen, "Frequency" tile.

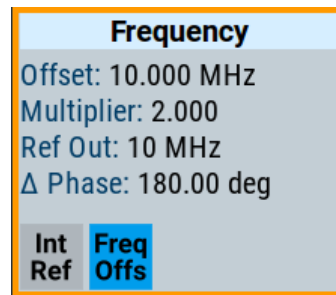

The "Frequency" tile indicates the reference frequency, current frequency offset and multiplier values, and phase offset value.

In the "RF Frequency" dialog, you can configure:

- RF frequency, incl. an offset or multiplication factor of a downstream instrument
- The step size for varying the frequency with the rotary knob.

The remote commands required to define the settings are described in [Chapter 14.16.4, "SOURCE:FREQUENCY Subsystem"](#), on page 624.

## Settings

Frequency.....	72
Main PLL Bandwidth.....	73
Offset.....	73
Multiplier.....	73
User Variation.....	73
L Variation Active.....	73
L Variation Step.....	73

## Frequency

Sets the RF frequency.

This frequency is output at the RF connector. It does not consider an [Offset](#) or multiplication factor ([Multiplier](#)).

See "[RF frequency and level display with a downstream instrument](#)" on page 68.

### Note: Suppressed values in the status bar

For security concerns or certain operating modes, you can hide the frequency and level display in the status bar.

- **\*\*\*\*\***

The display has been disabled for security reasons.

See:

- [Annotation Frequency](#)
- [Annotation Amplitude](#)

- 

The display is disabled when list mode is running, see [Chapter 7, "List and Sweep Mode"](#), on page 169.

Remote command:

`[ :SOURCE<hw> ] :FREQUENCY [ :CW | FIXEd ]` on page 626

**Main PLL Bandwidth**

Selects the PLL (Phase Locked Loop) bandwidth of the **main synthesizer**.

"Normal" Default main PLL bandwidth.  
The instrument provides the maximum modulation bandwidth and FM/PhiM deviation.

"Narrow" Sets the narrow PLL bandwidth.

Remote command:

[\[:SOURce<hw>\]:FREQuency:PLL:MODE](#) on page 631

**Offset**

Sets the frequency offset.

This value represents the frequency shift of a downstream instrument, like for example a mixer.

The "Frequency" value displayed in the status bar is the resulting frequency, as it is at the output of the downstream instrument. The frequency at the R&S SMA100B RF output is not changed.

See ["RF frequency and level display with a downstream instrument"](#) on page 68.

Remote command:

[\[:SOURce<hw>\]:FREQuency:OFFSet](#) on page 628

**Multiplier**

Sets the multiplication factor for the RF frequency.

This value represents the multiplication factor of a downstream instrument, as for example a multiplier. You can also assign a negative multiplication factor, for example -1.0 to support frequency converters working in the reverse frequency position.

The "Frequency" value displayed in the status bar is the resulting frequency, as it is at the output of the downstream instrument. The frequency at the R&S SMA100B RF output is not changed.

See ["RF frequency and level display with a downstream instrument"](#) on page 68.

Remote command:

[\[:SOURce<hw>\]:FREQuency:MULTIplier](#) on page 628

**User Variation**

Defines and activates a user-defined step width for varying the RF frequency or RF level with the rotary knob.

If disabled, the step width varies in steps of one unit at the cursor position.

**Variation Active ← User Variation**

Activates the set user-defined step width.

Remote command:

[\[:SOURce<hw>\]:FREQuency:STEP:MODE](#) on page 630

[\[:SOURce<hw>\]:POWer:STEP:MODE](#) on page 667

**Variation Step ← User Variation**

Sets the user-defined step width.

Remote command:

[ :SOURce<hw> ] :FREQuency:STEP [ :INCRe ment ] on page 630

[ :SOURce<hw> ] :POWer:STEP [ :INCRe ment ] on page 668

## 4.5 RF Level Settings

Access:

1. Select "Level" > "RF Level".

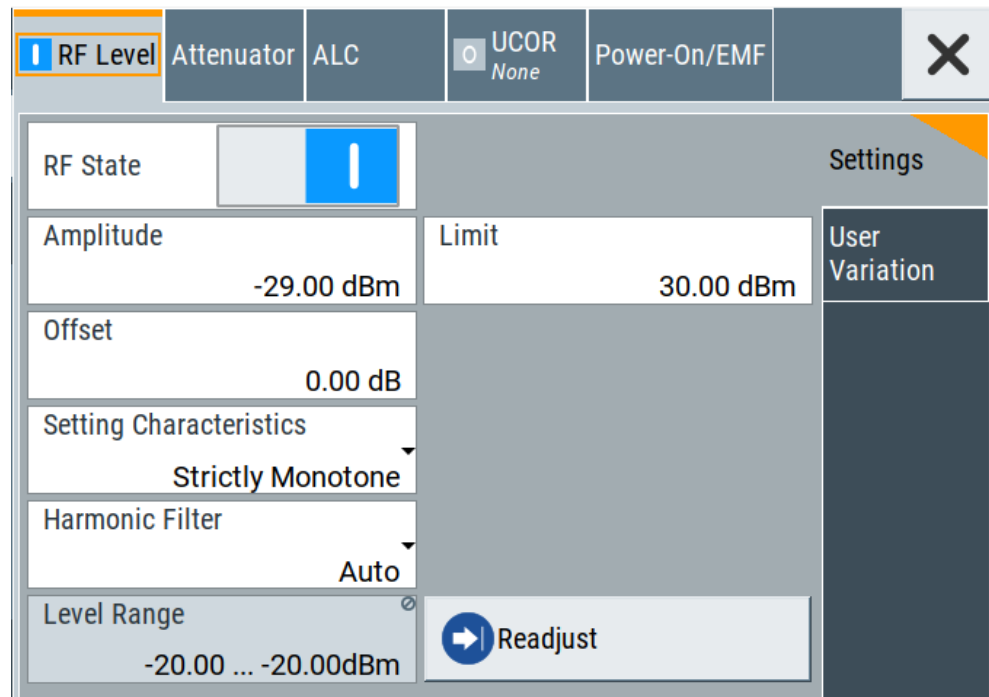

In the "RF Level" dialog, you can configure the offset-free level, the level limit, and the step width for varying the level with the rotary knob.

2. Select "User Variation" to set the step width to be used when .setting the RF level using the rotary knob.

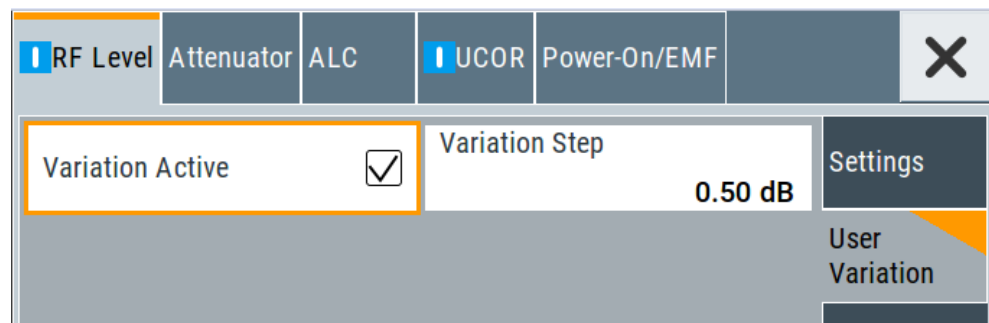

3. Observe the information on the home screen, "Level" tile.

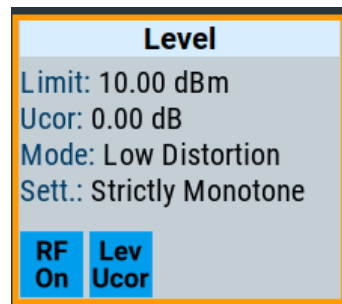

The "Level" tile indicates the level limit, the user correction status and current correction value, current setting characteristics incl. mode.

The remote commands required to define the settings are described in [Chapter 14.16.11, "SOURce:POWer Subsystem"](#), on page 662.

### Settings

RF State/RF ON.....	75
Amplitude.....	75
Limit .....	76
Offset .....	76
Setting Characteristics .....	76
Harmonic Filter .....	77
Level Range .....	77
Readjust.....	78
User Variation.....	78
L Variation Active.....	78
L Variation Step.....	78

### RF State/RF ON

Activates or deactivates the RF output.

Acts as the [RF on/off] key.

Remote command:

:OUTPut<hw> [:STATe] on page 475

### Amplitude

Sets the level of the RF signal.

The value is offset-free and corresponds to the level at the RF connector.

See "[RF frequency and level display with a downstream instrument](#)" on page 68.

### Note: Suppressed values in the status bar

For security concerns or certain operating modes, you can hide the frequency and level display in the status bar.

- \*\*\*\*\*

The display has been disabled for security reasons.

See:

- [Annotation Frequency](#)
- [Annotation Amplitude](#)



The display is disabled when list mode is running, see [Chapter 7, "List and Sweep Mode"](#), on page 169.

Remote command:

`[ :SOURce<hw> ] :POWer:POWer` on page 666

**Note:** The SCPI command `[ :SOURce<hw> ] :POWer [ :LEVel ] [ :IMMediate ] [ :AMPLitude ]` sets the level of the "Level" display.

This means, the level containing offset.

### Limit

Sets an upper limit for the RF output power.

You can use this value to protect your DUT from damage due to high input power. If you enter an RF level above this value, the instrument limits the output power to this specified value, and generates the warning message:

"Pep value greater than the defined limit." However, the level indication in the status bar is not affected.

The setting is not affected by an instrument preset ([Preset] key or \*RST) and the "Save/Recall" function. It is reset only by factory preset.

Remote command:

`[ :SOURce<hw> ] :POWer:LIMit [ :AMPLitude ]` on page 665

### Offset

Sets a level offset.

This value represents the level shift of a downstream instrument, like, for example, an attenuator or an amplifier.

The "Level" value displayed in the status bar is the resulting level, as it is at the output of the downstream instrument. The level at the R&S SMA100B RF output is not changed.

See ["RF frequency and level display with a downstream instrument"](#) on page 68.

Remote command:

`[ :SOURce<hw> ] :POWer [ :LEVel ] [ :IMMediate ] :OFFSet` on page 668

### Setting Characteristics

Selects additional quality characteristics to optimize the behavior of the RF signal level for the specific application.

"Auto"	Sets the RF output level automatically according to the selected mode. In this mode, the instrument provides the highest dynamic range and fastest setting times, as specified in the data sheet. The RF signal is shortly blanked when the step attenuator is switching.
--------	---



**"Uninterrupted"**

Suppresses blanking at level transitions. Frequency transitions can lead to an RF level blanking due to hardware specific switching points.

This mode reduces the dynamic range of the instrument. The step attenuator is fixed.

**"Strictly Monotone"**

Executes signal level changes monotonically increasing or decreasing.

The setting makes sure that increasing the level value exclusively results in an increased output level, and vice versa.

All electronic switches, which might affect the monotonicity are fixed. The operation mode is useful for applications using level searching algorithms which rely on a strictly monotonous behavior.

**"Constant-VSWR"**

Suppresses output impedance variations at the RF output connector, due to changed level settings.

**"High Dyn. Uninterrupted"**

R&S SMAB-K724

Provides a linear output power that is uninterrupted over a wide dynamic range.

**Note:** The R&S SMA100B supports this characteristic at frequencies above 52 MHz. If you select the setting at lower frequencies ( $\leq 52$  MHz), the instrument reports a settings conflict.

**"User"**

Indicates that a setting has been modified in the expert mode. The expert mode is a protected function, that requires protection level 2 password.

Remote command:

`[ :SOURce<hw> ] :POWer:LBEHaviour` on page 665

**Harmonic Filter**

Activates low harmonic filter or enables its automatic switching.

**"On"**

Ensures best low harmonics performance but decreases the level range.

**"Auto"**

Applies an automatically selected harmonic filter that fits to the current level setting.

Remote command:

`:OUTPut<hw>:FILTer:MODE` on page 476

**Level Range**

Shows the interruption-free range of the level that you can use in the currently selected mode.

Remote command:

`[ :SOURce<hw> ] :POWer:RANGe:LOWer?` on page 670

`[ :SOURce<hw> ] :POWer:RANGe:UPPer?` on page 670

**Readjust**

Recalculates and adjusts the internal switch positions of the RF chain according to the current level.

Remote command:

[ :SOURce<hw> ] :POWer:ALC:SONCe on page 664

**User Variation**

Defines and activates a user-defined step width for varying the RF frequency or RF level with the rotary knob.

If disabled, the step width varies in steps of one unit at the cursor position.

**Variation Active ← User Variation**

Activates the set user-defined step width.

Remote command:

[ :SOURce<hw> ] :FREQuency:STEP:MODE on page 630

[ :SOURce<hw> ] :POWer:STEP:MODE on page 667

**Variation Step ← User Variation**

Sets the user-defined step width.

Remote command:

[ :SOURce<hw> ] :FREQuency:STEP [ :INCRement ] on page 630

[ :SOURce<hw> ] :POWer:STEP [ :INCRement ] on page 668

## 4.6 RF Phase Settings

The phase in sinusoidal signals defines the initial angle at its origin.

Access:

1. Select "Frequency" > "Phase".

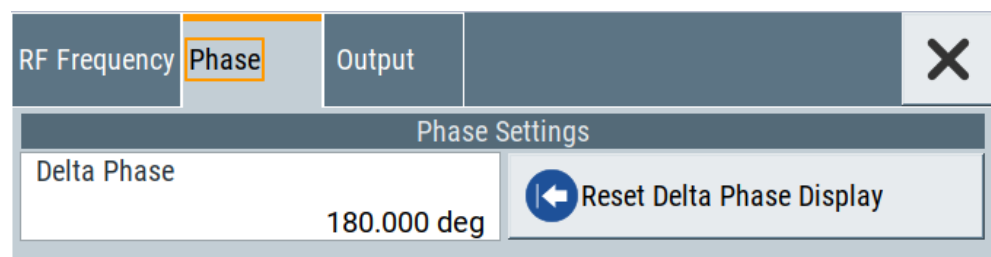

In the "Phase" tab, you can determine the delta phase value and reset the phase to this reference.

2. Observe the information on the home screen, "Frequency" tile.

The "Frequency" tile indicates used reference frequency, current frequency offset and multiplier values, and the delta phase value.

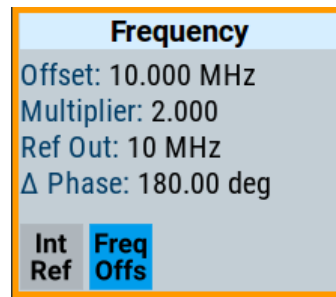

The remote commands required to define the settings are described in [Chapter 14.16.10, "SOURCE:PHASe Subsystem"](#), on page 661.

### Settings

<a href="#">Delta Phase</a> .....	79
<a href="#">Reset Delta Phase Display</a> .....	79

### Delta Phase

Sets the phase of the RF signal.

The current phase of the signal is used as the reference.

Remote command:

[ :SOURCE<hw> ] : PHASe on page 661

### Reset Delta Phase Display

Adopts the selected "Delta Phase" value as the current value, and resets delta phase to 0 degrees.

Remote command:

[ :SOURCE<hw> ] : PHASe:REFeRence on page 661

## 5 Analog Modulations

The R&S SMA100B supports AM (amplitude modulation), FM (frequency modulation),  $\Phi$ M (phase modulation (PhiM)), and also PULM (pulse modulation). It generates low frequency signals (LF) as sine, triangle, trapezoidal or square (pulse) waveform, that can be output and further processed by a downstream instrument.

### 5.1 Required Options

R&S SMA100B base unit equipped with the following options:

- Option frequency (R&S SMAB-B10x)
- Option pulse modulator (R&S SMAB-K22)
- Option pulse generator (R&S SMAB-K23)  
(supports generation of single and double pulse signals)
- Option multi-function generator (R&S SMAB-K24)
- Option pulse train generator (R&S SMAB-K27)  
(requires R&S SMAB-K23)
- Option AM/FM/PhiM (R&S SMAB-K720)
- Option Scan AM (R&S SMAB-K720 and R&S SMAB-K721)
- Option Chirp Signal Generation (R&S SMAB-K725)  
(requires R&S SMAB-K22  
R&S SMAB-K23, providing extended ranges for resolution, pulse width and pulse period  
R&S SMAB-K720)

For more information, see data sheet.

### 5.2 Modulation Types and Signal Sources

Radio transmitters do not transmit an audio signal directly. Instead, they modulate the audio signal onto a continuous wave (CW) carrier with much higher frequency.

A CW carrier has a sinusoidal waveform with constant amplitude and constant frequency. Modulating a signal onto the carrier means varying a property of the carrier according to the modulating signal. The three basic modulation types FM, AM and PhiM for example, vary one property of the carrier proportional to the instantaneous amplitude of the modulating signal.

#### Signal sources

If fully equipped, the R&S SMA100B modulates signals from the following sources:

- **Internal modulation source**
  - *Two LF generators*

Each of the LF generators provides a modulation signal with sine, pulse, triangle or trapezoid shape.

- *Noise generator*  
The noise generator supplies white noise with selectable bandwidth and distribution.
- *High-performance pulse generator*  
Generates single and double pulse, or pulse train signals.
- **External modulation source**
  - Amplitude, frequency or phase modulation signals are input at the Ext connector.
  - Pulse modulation signals, at the Pulse Ext connector.

### Signal output

You can perform AM, FM and PhiM with the signal of any of the provided sources. Moreover, you can combine two modulation signals and generate a two-tone signal. Regardless of the signal source, the generated signal can be output for further processing in a downstream instrument.

Current configuration is indicated in the "Analog Modulations > Overview" dialog; the output signal routing can be changed, too.

### Input and output connectors

Direction	Modulation	Connector	Required option
Output	Pulse modulation from internal signal Loop through of pulse signal from Pulse Ext	Pulse Video	R&S SMAB-K22/-K23
	All analog modulations Marks the valid level and frequency Inverted version; the output signal is low during the valid signal times.	Signal Valid Signal Valid Neg.	
	Chirp Modulation	Pulse Video Pulse Sync	R&S SMAB-K22/-K23
	Pulse generator	Pulse Sync	
	LF generator	LF	
Input	AM, FM, PhiM	Ext **)	R&S SMAB-K720
	Pulse modulation from external source*) Or External trigger or gate signal*)	Pulse Ext**)	R&S SMAB-K22

- \*) External trigger signal and external signal for the pulse modulation cannot be used simultaneously, because these signals are expected at the same connector Pulse Ext. Signal polarity and impedance are the same for both signals.

- \*\*) The external modulation signal must have a voltage of  $U_S = 1 \text{ V}$  ( $U_{EFF} = 0.707 \text{ V}$ ) to achieve the displayed modulation depth and range.  
Note that the input voltage does not exceed 1 V, otherwise modulation distortions can occur.

For more information, see data sheet.

#### Interactions and characteristics

- FM and PhiM modulations exclude each other and cannot be performed simultaneously.
- In sweep mode, LF frequency sweep is possible.
- The settings of the modulation signal affect all analog modulations that use an internal modulation source.
- You can feed an external LF signal in each of the two paths.
- Using exponential amplitude modulation with an external source, sets the coupling of the corresponding input automatically to DC.  
See also [Chapter 5.4.7.2, "Source > External Settings"](#), on page 116.
- If you use Scan AM with an external modulation input signal, the voltage range is adjusted to  $\pm 6 \text{ V}$  (usually  $\pm 1 \text{ V}$ ). Therefore, we recommend that you do not use the external modulation signal for FM or PhiM in parallel, since the voltage will affect the modulations.
- The amplitude modulation types linear and exponential derive the carrier signal either linear in percent / volt, or as complex exponential in dB / volt.
- Scan AM provides the scan mode, i.e. an amplitude modulation depth with an extended dynamic range that automatically uses the exponential amplitude modulation type.
- For pulse modulated signals, you can select between fast or smoothed transitions, see ["Transition Type"](#) on page 84.  
This setting is available over the entire frequency range for all instruments with frequency options up to 6 GHz. For higher frequency options, the frequency range for the smoothed setting is limited.

For more information, see data sheet.

## 5.3 Activating Analog Modulations

- ▶ Use one of the following:
  - Select "Modulation > Amplitude Modulation/Frequency Modulation/Phase Modulation > State > ON".
  - Select "Modulation > MOD ON".
  - Press the [Mod on/off] key.

#### [Mod on/off]

Activate one or more analog modulations and press the [Mod on/off] key to toggle the state of them all.

Pressing the key again restores the status that was active before the last switch-off.

Remote command:

`[ :SOURce<hw> ] :MODulation [ :ALL ] [ :STATe ]` on page 543

## 5.4 Modulation Settings

Access:

- ▶ Select "Modulation" > "Modulation Sources".

The "Modulation" dialog contains all functions and settings to configure the analog modulations, the LF signal sources for performing a modulation, and the LF signal output.

The remote commands required to define these settings are described in:

- [Chapter 14.16.1.2, "SOURce:AM Subsystem"](#), on page 544
- [Chapter 14.16.1.4, "SOURce:FM Subsystem"](#), on page 554
- [Chapter 14.16.1.5, "SOURce:PM Subsystem"](#), on page 559
- [Chapter 14.16.1.6, "SOURce:PULM Subsystem"](#), on page 563
- [Chapter 14.16.1.3, "SOURce:CHIRp Subsystem"](#), on page 550
- [Chapter 14.16.6, "SOURce:LFOutput Subsystem"](#), on page 632

### 5.4.1 Pulse Modulation

Option: see [Chapter 5.1, "Required Options"](#), on page 80.

Access:

- ▶ Select "Modulation" > "Pulse Modulation".

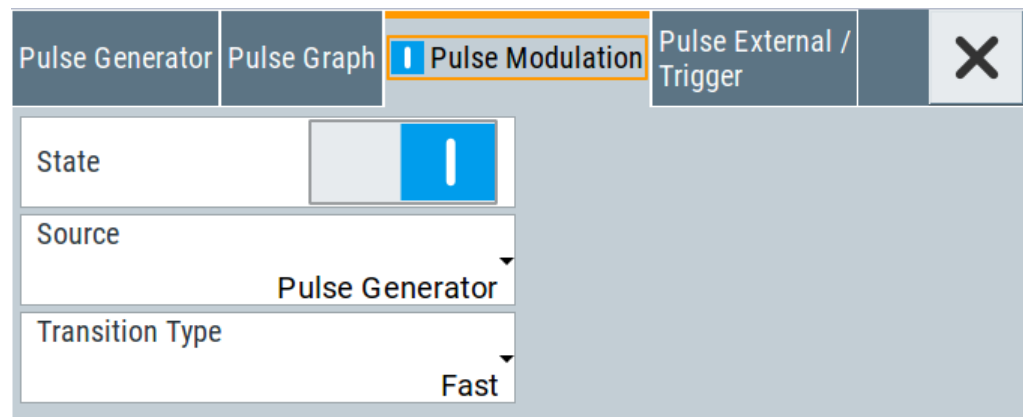

The "Pulse Modulation" dialog contains all parameters required to configure the pulse modulator and the pulse generator. It also displays the pulse signal graphically.

For an overview of the supported signals sources and related connectors, see [Chapter 5.2, "Modulation Types and Signal Sources"](#), on page 80.

The remote commands required to define these settings are described in [Chapter 14.16.1.6, "SOURce:PULM Subsystem"](#), on page 563.

### Settings:

State.....	84
Source.....	84
Transition Type.....	84

### State

Activates pulse modulation and triggers the following automatic settings:

- Pulse generator is activated.  
The signal is output at the Pulse Video connector.  
To deactivate the signal output, set "Pulse Generator" > [Pulse Output State](#) > "Off".

Remote command:

[ :SOURce<hw> ] :PULM:STATe on page 567

### Source

Selects between the internal "Pulse Generator" or an "External" pulse signal for the modulation.

"Pulse Generator"

Selects the internal generator.

See [Pulse Generator](#).

"External"

Modulation source is fed to the input connector.

See ["Signal sources"](#) on page 80.

Remote command:

[ :SOURce<hw> ] :PULM:SOURce on page 567

### Transition Type

Selects between "Fast" or "Smoothed" slew rate (slope).

"Fast"

Enables fast transitions with shortest rise and fall times.

"Smoothed"

Flattens the slew rate, resulting in longer rise / fall times. Use this mode if you are working with devices that are sensitive to steep slopes.

**Note:** The R&S SMA100B supports this functionality up to a certain frequency, depending on the installed frequency options, see also ["Interactions and characteristics"](#) on page 82.

For more information, see data sheet.

Remote command:

[ :SOURce<hw> ] :PULM:TTYPe on page 567



## 5.4.2 FM, PhiM and AM Modulation Settings

Option: R&S SMAB-K720

Access:

- ▶ Select "Modulation" > "Amplitude Modulation/Frequency Modulation/Phase Modulation".

Path 1		Path 2	
State	<input checked="" type="checkbox"/>	State	<input checked="" type="checkbox"/>
Source	LF Generator 1	Source	External 1
Deviation	1.000 00 kHz	Deviation	1.000 00 kHz
Deviation Mode	Fixed Ratio	Ratio Path 2 / Path 1	100.00 %
Mode	High Bandwidth		

The "FM", "ΦM" and "AM" tabs contain the parameters per modulation type.

### Source

State.....	86
Source.....	86
FM settings.....	86
L Deviation.....	86
L Deviation Mode.....	87
L Total Deviation.....	87
L Ratio Path2/Path1.....	87
L Mode.....	87
PhiM settings.....	88
L Deviation.....	88
L Deviation Mode.....	88
L Total Deviation.....	88
L Ratio Path2/Path1.....	89
L Mode.....	89
AM settings.....	89
L Mode.....	90

L Type.....	90
L Depth.....	91
L Sensitivity.....	91
L Deviation Mode.....	91
L Total Depth.....	91
L Ratio Path2/Path1.....	92

**State**

Activates a modulation.

**Note:** Some modulations exclude each other and cannot be performed simultaneously. For more information, see data sheet.

Remote command:

[ :SOURce<hw> ] :AM<ch> :STATe on page 546

[ :SOURce<hw> ] :FM<ch> :STATe on page 556

[ :SOURce<hw> ] :PM<ch> :STATe on page 560

**Source**

Selects the LF signal source.

You can vary the signal sources for each of the modulations.

"LF Generator 1/2"

Selects one or both of the internally generated LF signals.

See [Chapter 5.4.7.1, "Source > LF Generator Settings"](#), on page 112.

"External 1/2" Selects an externally supplied LF signal.

"Noise Generator"

Selects the internally generated noise signal.

See [Chapter 5.4.7.3, "Source > Noise Generator Settings"](#), on page 118.

Remote command:

[ :SOURce<hw> ] :AM<ch> :SOURce on page 547

[ :SOURce<hw> ] :FM<ch> :SOURce on page 556

[ :SOURce<hw> ] :PM<ch> :SOURce on page 561

**FM settings**

The following settings are dedicated to FM.

**Deviation ← FM settings**

Sets the frequency modulation deviation in Hz.

The maximal deviation depends on the RF frequency and the selected modulation mode (see data sheet).

Maximal possible deviation is selected automatically, if one of the following applies:

- The selected deviation is too high for the particular frequency
- The selected frequency is outside of the range where deviation is possible.

A warning message indicates this situation, too.

Remote command:

`[ :SOURce<hw> ] :FM<ch> [ :DEViation ]` on page 556

#### Deviation Mode ← FM settings

Enables you to couple the LF signal of both paths and determines the mode for fixing the total deviation.

The total deviation is the sum of both paths. When the sum is exceeded, the R&S SMA100B reports a settings conflict, but does not change the settings.

- |               |  |
|---------------|--|
| "Uncoupled"   | Enables you to adjust the deviation for each path independently.   |
| "Fixed Total" | Couples the deviation of both paths in per Hz. If you change the deviation of any path, the R&S SMA100B automatically adjusts the value of the other path. The sum always results in the set <a href="#">Total Deviation</a> . |
| "Fixed Ratio" | Couples the deviation ratio of both paths. If you change the deviation of any path, the R&S SMA100B adjusts the value of the other path.   |

Remote command:

`[ :SOURce<hw> ] :FM:DEViation:MODE` on page 557

#### Total Deviation ← FM settings

Sets the sum of the signal deviation for path 1 and path 2 in Hz when using combined sources in [Deviation Mode > Fixed Total](#).

[Deviation](#) of both paths always sum up to the value of the total deviation.

Behavior when changing any depth settings:

- Changing the total deviation adjusts the deviation of both paths proportionally.
- Changing the deviation of one path adjusts the deviation of the other path. The sum always results in the set total deviation.

Remote command:

`[ :SOURce<hw> ] :FM:DEViation:SUM` on page 557

#### Ratio Path2/Path1 ← FM settings

Sets the deviation ratio (path2 to path1) in percent.

#### Example:

If the deviation in path1 is 10 kHz and the ratio is 50%, the deviation in path 2 is automatically set to 5 kHz.

Remote command:

`[ :SOURce<hw> ] :FM:RATio` on page 558

#### Mode ← FM settings

Selects the mode of the frequency modulation.

- |                  |  |
|------------------|--|
| "High Bandwidth" | The maximum range for modulation bandwidth is available. |
|------------------|--|

"Low Noise" Phase modulation with phase noise and spurious characteristics close to CW mode. The range for modulation bandwidth and FM deviation is reduced (see data sheet).  
To reduce the phase noise further, set the [Main PLL Bandwidth](#) = "Narrow"

Remote command:

`[ :SOURce<hw> ] :FM:MODE` on page 558

### PhiM settings

The following settings are dedicated to PhiM.

#### Deviation ← PhiM settings

Sets the phase modulation deviation in radians or degrees.

The maximal deviation depends on the RF frequency and the selected modulation mode (see data sheet).

Maximal possible deviation is selected automatically, if one of the following applies:

- The selected deviation is too high for the particular frequency
- The selected frequency is outside of the range where deviation is possible.

A warning message indicates this situation, too.

Remote command:

`[ :SOURce ] :PM<ch> [ :DEViation ]` on page 563

#### Deviation Mode ← PhiM settings

Enables you to couple the LF signal of both paths and determines the mode for fixing the total deviation.

The deviation sum 2 rad at a maximum. When the sum is exceeded, the R&S SMA100B adjusts the settings automatically.

"Uncoupled" Enables you to adjust the deviation for each path independently.

"Fixed Total" Couples the deviation of both paths. If you change the deviation of any path, the R&S SMA100B automatically adjusts the value of the other path. The sum always results in the set [Total Deviation](#).

"Fixed Ratio" Couples the deviation ratio of both paths. If you change the deviation of any path, the R&S SMA100B adjusts the value of the other path.

Remote command:

`[ :SOURce<hw> ] :PM:DEViation:MODE` on page 562

#### Total Deviation ← PhiM settings

In [Deviation Mode = Fixed Total](#), sets the sum of the signal deviation for path 1 and path 2.

[Deviation](#) of both paths always sum up to the value of the total deviation.

Behavior when changing any depth settings:

- Changing the total deviation adjusts the deviations of both paths proportionally.
- Changing the deviation of one path adjusts the deviation of the other path. The sum always results in the set total deviation.

Remote command:

`[ :SOURce<hw> ] :PM:DEViation:SUM` on page 562

**Ratio Path2/Path1 ← PhiM settings**

Sets the deviation ratio (path2 to path1) in per cent.

**Example:**

If the deviation in path1 is 10 rad and the ratio is 50%, the deviation in path 2 is automatically set to 5 rad.

Remote command:

`[ :SOURce<hw> ] :PM:RATio` on page 562

**Mode ← PhiM settings**

Selects the mode of the phase modulation.

**"High Bandwidth"**

The maximum range for modulation bandwidth and PhiM deviation is available.

However, phase noise increases at low frequencies, and the range of PhiM deviation is limited. This mode is suitable if you process high frequencies.

**"High Deviation"**

The maximum range for PhiM deviation is available.

Phase noise is improved for low frequencies compared to the default mode. The range for modulation frequency is limited (see data sheet). This mode is suitable for low modulation frequencies and/or high PhiM deviation.

**"Low Noise"**

Frequency modulation with phase noise and spurious characteristics close to CW mode. The range for modulation bandwidth and FM deviation is reduced (see data sheet).

Remote command:

`[ :SOURce<hw> ] :PM:MODE` on page 561

**AM settings**

The following settings are dedicated to AM.

Sources		<input checked="" type="radio"/> FM	<input type="radio"/> $\Phi$ M	<input checked="" type="radio"/> AM	<input type="radio"/> Output	Overview	✕
Mode		Normal		Type		Linear	
Path 1				Path 2			
State		<input checked="" type="checkbox"/>		State		<input checked="" type="checkbox"/>	
Source		LF Generator 1		Source		External 1	
Depth		30.00 %		Sensitivity		30.0 %/V	
Deviation Mode		Fixed Ratio		Ratio Path 2 / Path 1		100.00 %	

**Mode ← AM settings**

Selects the mode to derive the carrier signal for amplitude modulation.

- "Normal"      Performs the standard amplitude modulation with a single sinusoidal carrier signal.
- "Scan"      (Option: R&S SMAB-K721)  
Performs amplitude modulation with a higher dynamic range. The R&S SMA100B provides a special exponential amplitude modulation system optimized for highest dynamic range. You can use the scan mode to emulate level behaviors of transmitter/receiver systems with rotating antennas. Selecting "Mode > Scan" sets the modulation type to "Exponential".  
**Note:** Using exponential AM with an external source affects other operating modes as described in ["Interactions and characteristics"](#) on page 82.

Remote command:

[ :SOURce<hw> ] :AM:MODE on page 548

**Type ← AM settings**

Selects the type of the amplitude modulation for both paths.

Using exponential AM with an external source affects the coupling mode and the external modulation input, see ["Interactions and characteristics"](#) on page 82.

- "Linear"      Sets linear amplitude modulation with depths specified in percent / volt.
- "Exponential"      Sets the exponential AM type with depths in dB / volt.

Remote command:

[ :SOURce<hw> ] :AM:TYPE on page 550

#### Depth ← AM settings

Determines the depth of the modulation signal in percent.

For "Type = Exponential", the unit of "AM Depth" changes to dB.

The depth is limited by the maximum peak envelope power (PEP).

Remote command:

[ :SOURce<hw> ] :AM<ch>:DEPTH:LINear on page 547

[ :SOURce<hw> ] :AM<ch>:DEPTH:EXponential on page 548

#### Sensitivity ← AM settings

Sets the input sensitivity of the external modulation signal.

Remote command:

[ :SOURce<hw> ] :AM<ch>:SENSitivity[:LINear] on page 550

[ :SOURce<hw> ] :AM<ch>:SENSitivity:EXponential on page 549

#### Deviation Mode ← AM settings

Enables you to couple the LF signal of both paths and determines the mode for fixing the total deviation.

The deviation sum of both paths is 100% in total. When the sum is exceeded, the R&S SMA100B reports a settings conflict, but does not change the settings.

- |               |  |
|---------------|--|
| "Uncoupled"   | Enables you to adjust the deviation depth for each path independently.   |
| "Fixed Total" | Couples the deviation depth of both paths in per cent. If you change the depth of any path, the R&S SMA100B automatically adjusts the value of the other path. The sum always results in the set <a href="#">Total Depth</a> . |
| "Fixed Ratio" | Couples the deviation ratio of both paths. If you change the depth of any path, the R&S SMA100B adjusts the value of the other path.   |

Remote command:

[ :SOURce<hw> ] :AM:DEVIation:MODE on page 549

#### Total Depth ← AM settings

Sets the sum of the signal [Depth](#) for path 1 and path 2 in per cent when using combined sources and [Deviation Mode > Fixed Total](#).

Using external LF signals, the R&S SMA100B indicates the [Sensitivity](#) per Volts for the input signal.

Provided both signal paths are turned on, the depth of both paths always sum up to the value of the total depth.

Behavior when changing any depth settings:

- Changing the total depth adjusts the depths of both paths proportionally.
- Changing the depth of one path adjusts the depth of the other path. The sum always results in the set total depth.

Remote command:

[ :SOURce<hw> ] :AM:DEPTh:SUM on page 548

#### Ratio Path2/Path1 ← AM settings

Sets the deviation ratio of the signal depth for path 2 to path 1 in per cent when using combined sources.

Using external LF signals, the R&S SMA100B indicates the [Sensitivity](#) per Volts for the input signal.

In conjunction with the deviation mode, you can set the depth of both paths independently or coupled.

- [Deviation Mode > Uncoupled](#)  
Enables you to set the [Depth](#) or [Sensitivity](#) of both paths independently.
- [Deviation Mode > Fixed Ratio](#)  
Couples the ratio of the two paths as follows.
  - Changing the ratio path2/path1 adjusts the depth of both path2. The depth of path1 remains the same
  - Changing the depth of one path adjusts the depth of the other accordingly. The ratio path2/path1 remains the same.

Remote command:

[ :SOURce<hw> ] :AM:RATio on page 549

### 5.4.3 Chirp Modulation

Option: see [Chapter 5.1, "Required Options"](#), on page 80.

#### About chirp modulation

Chirp modulation is used in radar technique to achieve pulse compression. Pulse compression increases the sensitivity and resolution of radar systems by modifying transmitted pulses to improve their auto-correlation properties. To chirp the radar signal is one way of accomplishing pulse compression. A chirp is a signal with increasing or decreasing frequency over time.

The R&S SMA100B always couples the chirp modulation with the pulse modulation. It generates the modulation signals for FM and pulse modulator, and synchronizes the signals internally. The internal pulse generator signal is the modulation source for the pulse modulator, and the internal LF generator signal is the signal source for the frequency modulation. Normal FM mode is used. Using external modulation signals is not possible for chirp modulation.

The following graph shows the FM demodulated signal of chirped pulses with a chirp bandwidth of 80 MHz and a pulse width of 80 µs. Chirp direction is up.



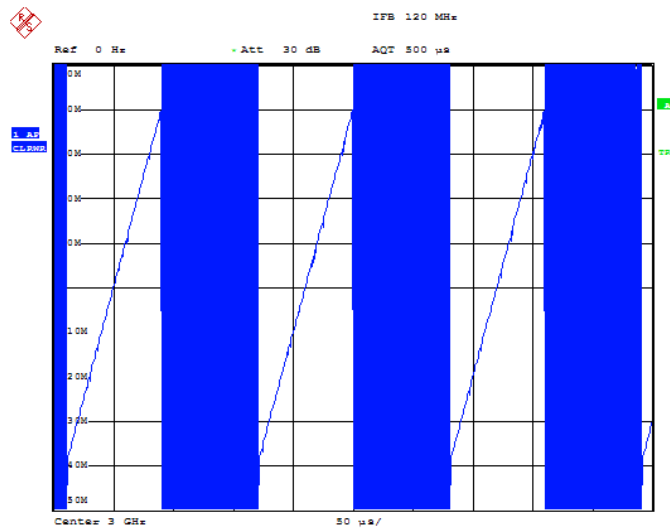

Date: 10.MAR.2008 15:38:01

### Dependencies and their effects between chirp modulation and other operating modes

Some modulations exclude each other and cannot be performed simultaneously.

When pulse modulation is activated, the R&S SMA100B deactivates ALC automatically ("ALC OFF", i.e. switches to "Sample & Hold" state).

The "Sample & Hold" state opens the ALC loop, and disables the automatic control of the output level. The level modulator is set directly.

However, to correct the output level, the R&S SMA100B executes a "Sample & Hold" measurement after each change of frequency or level settings.

The nominal level is used for typically 3 ms to 5 ms after level or frequency setting, if:

- No attenuator is fitted.
- "High Power" mode is enabled.
- "Auto" mode is enabled, and if the level is in the range of the high power, i.e. the mechanical relay bypass is switched.

The level is decreased by 30 dB during "Sample & Hold" measurement.

For more information, see data sheet.



The Sample&Hold measurement for the ALC is performed at the chirp center frequency. Therefore, the frequency response of the RF path can result in level errors for the FM modulated carrier especially with high chirp bandwidths.

### 5.4.3.1 Chirp Modulation Settings

Option: see [Chapter 5.1, "Required Options"](#), on page 80.

- [Chirp Modulation](#).....94
- [Pulse External / Trigger](#) .....97

#### Chirp Modulation

Access:

- ▶ Select "Modulation" > "Chirp Modulation".

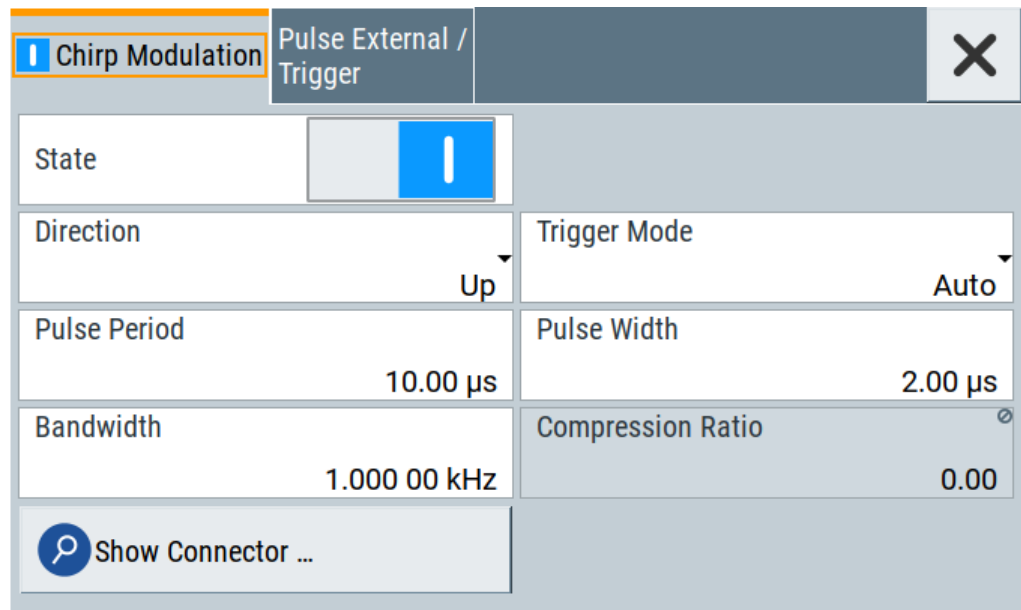

The "Chirp Modulation" dialog contains the parameters for configuring the modulation and trigger settings.

<a href="#">State</a> .....	94
<a href="#">Direction</a> .....	95
<a href="#">Pulse Period</a> .....	95
<a href="#">Bandwidth</a> .....	95
<a href="#">Trigger Mode</a> .....	96
<a href="#">Pulse Width</a> .....	96
<a href="#">Compression Ratio</a> .....	96
<a href="#">Show Connector</a> .....	96
<a href="#">Execute Single Trigger</a> .....	96

#### State

Activates chirp modulation.

**Note:** Some modulations exclude each other and cannot be performed simultaneously. For more information, see data sheet.

Remote command:

[ :SOURce<hw> ] :CHIRp:STATe on page 553

### Direction

Selects the direction of the chirp modulation.

"Up" The chirp starts with the lower frequency.

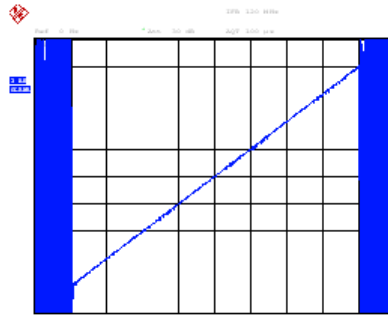

"Down" The chirp starts with the higher frequency.

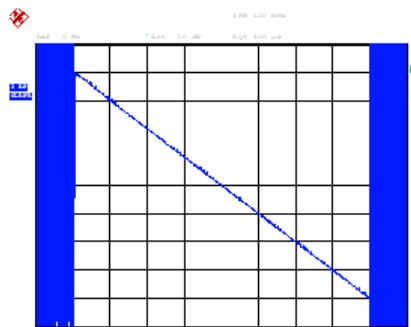

Remote command:

[ :SOURce<hw> ] :CHIRp:DIRectiOn on page 552

### Pulse Period

Sets the period of the generated chirp. Option R&S SMA100B-K23 provides higher resolution.

For more information, see data sheet.

Remote command:

[ :SOURce<hw> ] :CHIRp:PULSe:PERiod on page 552

### Bandwidth

Sets the modulation bandwidth in Hz.

The modulation bandwidth is the difference between the maximum and minimum frequency. E.g. a bandwidth of 10 MHz at a center frequency of 1 GHz leads to a frequency modulation between 995 MHz and 1005 MHz.

The maximum bandwidth depends on the installed frequency option and the RF frequency. If the bandwidth exceeds the RF frequency, or the frequency is out of the bandwidth range, the R&S SMA100B sets the maximum bandwidth and generates an error message.

For more information, see data sheet.

Remote command:

[\[:SOURce<hw>\]:CHIRp:BANDwidth](#) on page 552

### Trigger Mode

Selects the trigger mode for chirp modulation signals.

To supply the external trigger signal, use the Pulse Ext connector.

- "Auto" Generates the chirp modulation signal continuously.
- "Single" Generates the chirp modulation signal once, triggered internally with ["Execute Single Trigger"](#) on page 96.
- "Ext Single" Generates a single chirp pulse, triggered by an external signal.
- "Ext Triggered" Generates the chirp pulse each time an external trigger event occurs.
- "Extern Gated" Generates the chirp pulse signal triggered by an external gate signal.

Remote command:

[\[:SOURce<hw>\]:CHIRp:TRIGger:MODE](#) on page 553

### Pulse Width

Sets the width of the generated pulse. The pulse width must be at least 1 us less than the set pulse period. Option R&S SMA100B-K23 provides a higher resolution.

For more information, see data sheet.

Remote command:

[\[:SOURce<hw>\]:CHIRp:PULSe:WIDTh](#) on page 553

### Compression Ratio

Indicates the pulse compression ratio, i.e. the product of the pulse width in (s) and the bandwidth (Hz). Pulse compression increases the range resolution and the signal to noise ratio of pulsed signals.

Remote command:

[\[:SOURce<hw>\]:CHIRp:COMPression:RATio?](#) on page 552



### Show Connector

Accesses a dialog that displays the physical location of the selected connector on the front/rear panel of the instrument.

### Execute Single Trigger

If [\[:SOURce<hw>\]:CHIRp:TRIGger:MODE > SINGLE](#) "Trigger Mode = Single", initiates a single pulse sequence manually.

Remote command:

[\[:SOURce<hw>\]:CHIRp:TRIGger:IMMediate](#) on page 553

### Pulse External / Trigger

Access:

1. Select "Modulation" > "Chirp Modulation".
2. Select "Pulse External / Trigger".

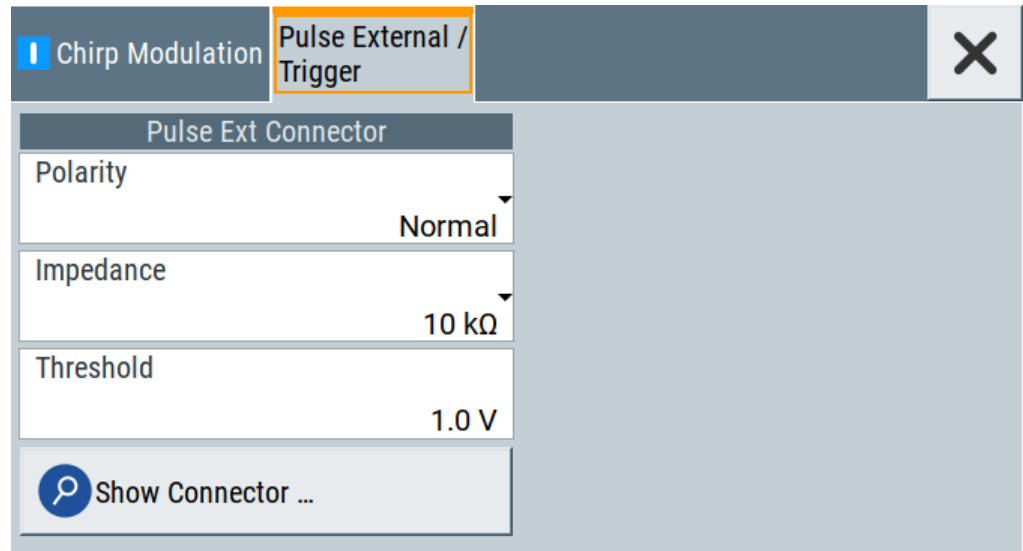

The "Pulse External / Trigger" dialog contains the parameters for configuring the externally applied pulse and trigger signals.

[Show Connector](#).....97



#### Show Connector

Accesses a dialog that displays the physical location of the selected connector on the front/rear panel of the instrument.

### 5.4.4 Pulse Generator

Option: see [Chapter 5.1, "Required Options"](#), on page 80.

Access:

- ▶ Select "Modulation" > "Pulse Modulation > Pulse Generator".

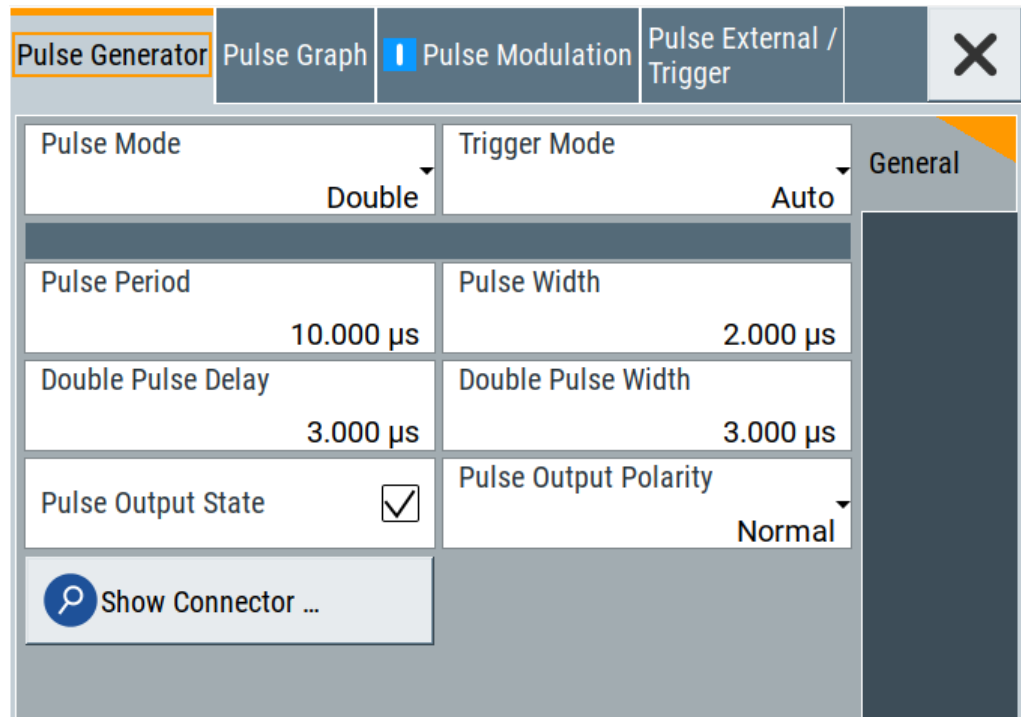

The "Pulse Generator" tab contains the settings for creating the pulse modulation signal internally.

- [Pulse Generator > General Settings](#)..... 98
- [Pulse Generator > Pulse Train Settings](#)..... 103
- [Import/Export List Files](#)..... 107

#### 5.4.4.1 Pulse Generator > General Settings

Access:

- ▶ Select "Modulation" > "Pulse Modulation > Pulse Generator".

#### Settings

- [Pulse Mode](#)..... 99
- [Trigger Mode](#)..... 100
- [Pulse Period](#)..... 102
- [Pulse Width](#)..... 102
- [Double Pulse Width](#)..... 103
- [Pulse Delay](#)..... 103
- [Double Pulse Delay](#)..... 103
- [Pulse Repetition Frequency](#)..... 103
- [Pulse Output State](#)..... 103
- [Show Connector](#)..... 103
- [Pulse Output Polarity](#)..... 103
- [Execute Single Trigger](#)..... 103

**Pulse Mode**

Sets the operating mode of the pulse generator. Depending on the selection, the instrument displays the associated parameters.

"Single" Generates a single pulse in one pulse period.

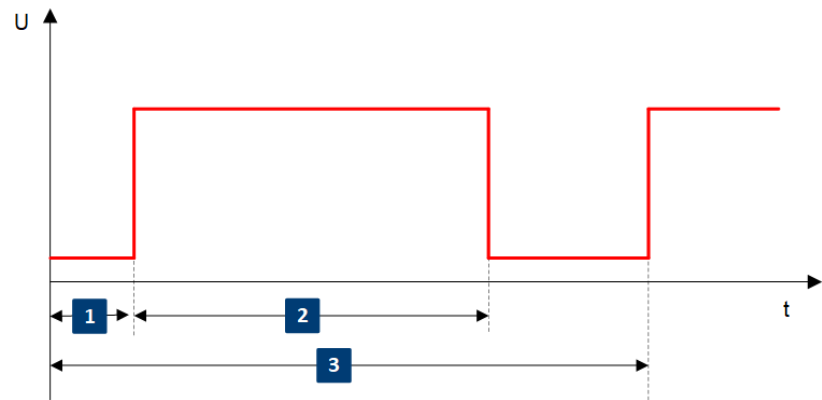

- 1 = Pulse delay
- 2 = Pulse width
- 3 = Pulse period

"Double" Generates two pulses in one pulse period.

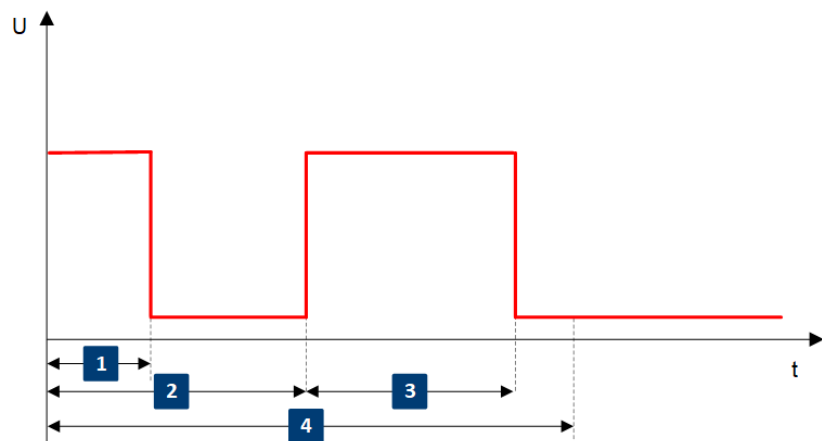

- 1 = Pulse width
- 2 = Double pulse delay
- 3 = Double pulse width
- 4 = Pulse period

"Train"

Option: R&S SMAB-K27  
Generates a user-defined pulse train.

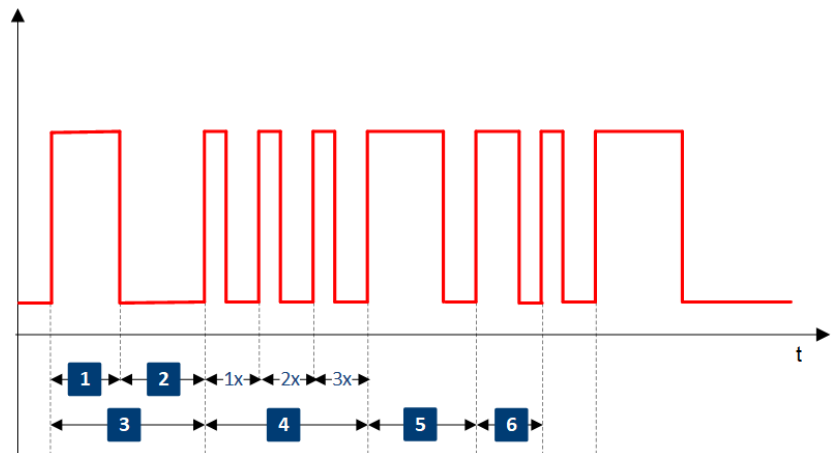

- 1 = 1st pulse: On-time
- 2 = 1st pulse: Off-time
- 3 = 1st pulse: pulse period
- 4 = 2nd pulse: repeated 3 times
- 5 = 3rd pulse
- 6 = 4th pulse

See [Chapter 5.4.4.2, "Pulse Generator > Pulse Train Settings"](#), on page 103.

Remote command:

[\[:SOURce<hw>\]:PULM:MODE](#) on page 565

### Trigger Mode

Selects between continuous triggering or triggering initiated by a trigger event from an external signal.

See also ["Input and output connectors"](#) on page 81.

- "Auto" Generates the internal modulation signal continuously.
- "Single" The pulse generator is triggered by an internal trigger event, initiated with [Execute Single Trigger](#).  
The pulse signal is generated once.
- "Ext Single" Generates a single pulse signal, triggered by an external signal.



"Ext Triggered" Generates the pulse signal each time an external trigger event occurs.

**Example: Generation of single pulse signal ("Pulse Mode = Single") using "Trigger Mode = Ext Triggered"**

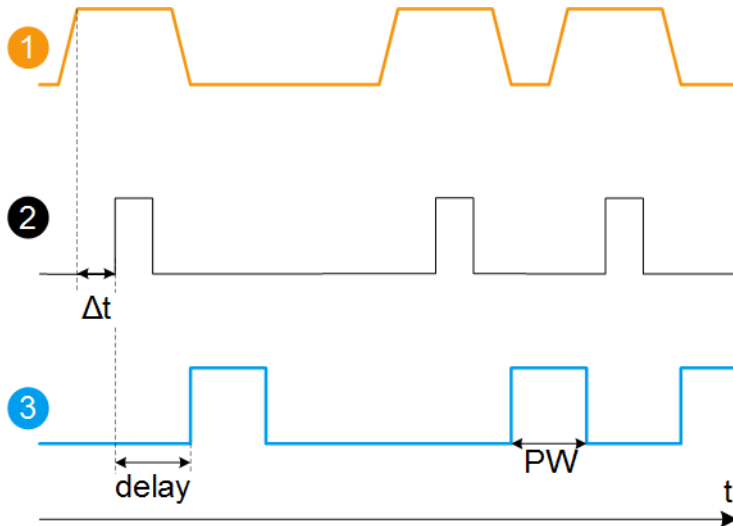

- 1 = External trigger signal input with "Trigger Input Polarity = Normal" (the positive slope is active)
- 2 = Sync signal
- 3 = Pulse signal
- $\Delta t$  = Trigger delay between the trigger and the sync signal start; see data sheet
- delay = "Pulse Delay = 100 ns"
- PW = "Pulse Width = 100 ns"

**Example: Generation of double pulse signal ("Pulse Mode = Double") using "Trigger Mode = Ext Triggered"**

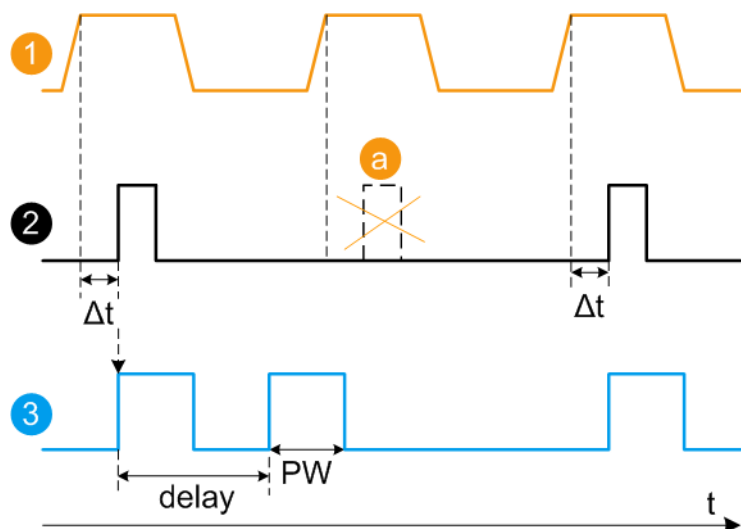

- 1 = External trigger signal input with "Trigger Input Polarity = Normal" (the positive slope is active)
- 2 = Sync signal

- 3 = Pulse signal
- a = Trigger signal during double pulse generation is without effect
- $\Delta t$  = Trigger delay between the trigger and the sync signal start; see data sheet
- delay = "Double Pulse Delay = 200 ns"; the first pulse starts without a delay
- PW = "Double Pulse Width = 100 ns"

"Ext Gated" Generates the signal triggered by an external gate signal.

**Example: Generation of single pulse signal ("Pulse Mode = Single") using "Trigger Mode = Ext Gated"**

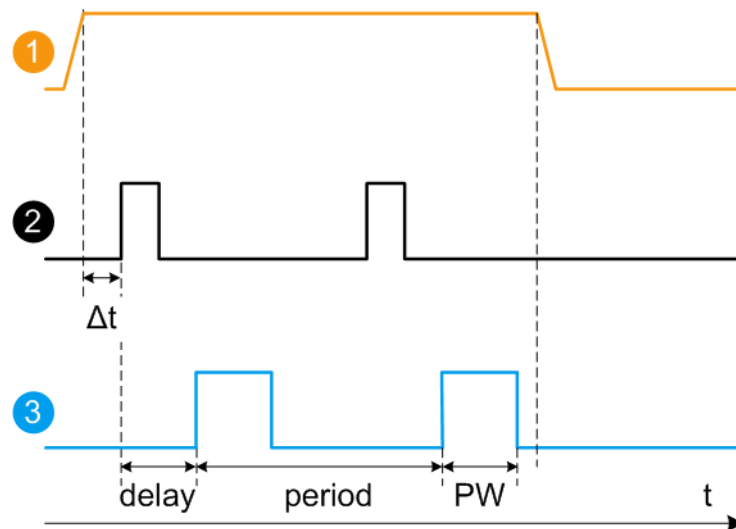

- 1 = External trigger signal input with "Trigger Input Polarity = Normal" (the positive slope is active)
- 2 = Sync signal
- 3 = Pulse signal
- $\Delta t$  = Trigger delay between the trigger and the sync signal start; see data sheet
- delay = "Pulse Delay = 100 ns"
- PW = "Pulse Width = 100 ns"
- period = "Pulse Period = 300 ns" (time between the pulse start of two consecutive pulses)
- a = Gate active duration (pulses are generated during the gate active part)

Remote command:

[\[:SOURCE<hw>\]:PULM:TRIGger:MODE](#) on page 565

**Pulse Period**

Sets the repetition rate of the generated pulse signal.

Remote command:

[\[:SOURCE<hw>\]:PULM:PERiod](#) on page 565

**Pulse Width**

Sets the pulse duration of the generated pulse signal.

**Note:** The pulse width must be at least 20 ns less than the set pulse period.

Remote command:

[\[:SOURCE<hw>\]:PULM:WIDTH](#) on page 566

**Double Pulse Width**

Sets the width of the second pulse.

Remote command:

`[ :SOURce<hw> ] :PULM:DOUBle:WIDTh` on page 567

**Pulse Delay**

Sets the pulse delay. The pulse delay determines the time that elapses after a trigger event before pulse modulation starts. The pulse delay is not effective for double pulse generation.

Remote command:

`[ :SOURce<hw> ] :PULM:DELay` on page 566

**Double Pulse Delay**

Sets the delay from the start of the first pulse to the start of the second pulse.

Remote command:

`[ :SOURce<hw> ] :PULM:DOUBle:DELay` on page 566

**Pulse Repetition Frequency**

Indicates the number of pulses of the repeating signal in a specific time unit.

The parameter is commonly expressed in Hz or in pulses per second (pps).

Remote command:

n.a.

**Pulse Output State**

Activates the output of the pulse modulation signal.

Remote command:

`[ :SOURce<hw> ] :PGENerator:OUTPut [ :STATe ]` on page 660

**Show Connector**

Accesses a dialog that displays the physical location of the selected connector on the front/rear panel of the instrument.

**Pulse Output Polarity**

Sets the polarity of the pulse output signal.

Remote command:

`[ :SOURce<hw> ] :PGENerator:OUTPut:POLarity` on page 660

**Execute Single Trigger**

If "Trigger Mode = Single", initiates a single pulse sequence manually.

Remote command:

`[ :SOURce ] :PULM [ :INTernal ] [ :TRAIIn ] :TRIGger:IMMediate` on page 565

**5.4.4.2 Pulse Generator > Pulse Train Settings**

Option: see [Chapter 5.1, "Required Options"](#), on page 80.

Access:

1. Select "Modulation" > "Pulse Modulation > Pulse Generator" > "**Pulse Mode = Train**".

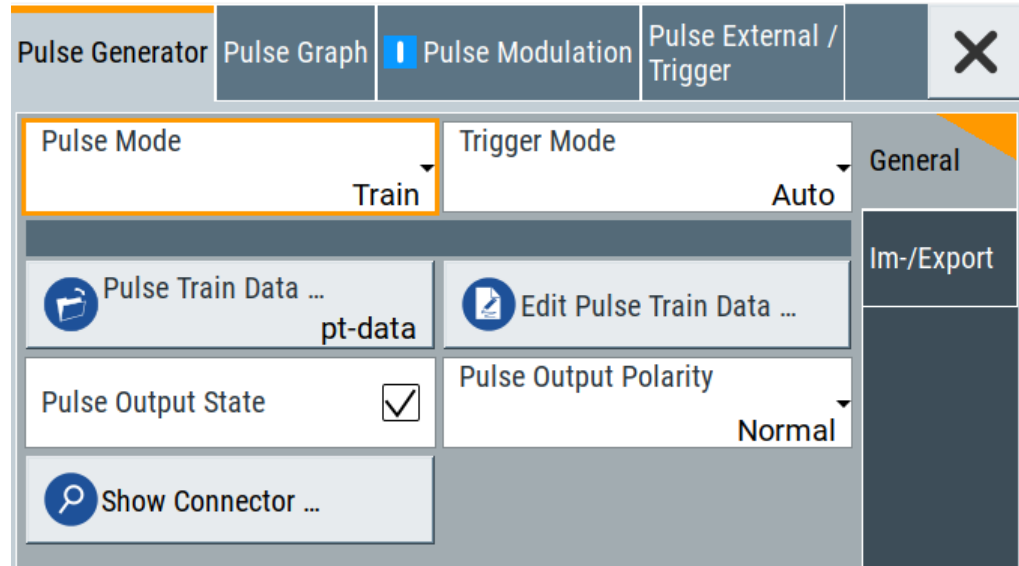

2. Select "Pulse Train Data".
3. Select an existing file or select "New" to create one.
4. Define the filename.  
Select "Edit Pulse Train Data", if the file is empty or to control and change the values.
5. In the "Edit Pulse Train Data" dialog, enter the pulse on/off times and pulse repetition values.
6. Select "Save".

A pulse train is a sequence of pulses with user-defined repetition, and pulse on and off times. Once defined, pulse train settings can be saved in a file. The filename is user-definable; the file extension (\*.pulstrn) is assigned automatically. When a file is selected, the filename is indicated.

### Possible ways to configure a pulse train

You can configure a pulse train in the following ways:

- **Internally**
  - Use the built-in editor table editor, see in the "Pulse Generator > Pulse Train" dialog.  
Once defined, pulse train settings can be saved in a file. For example, to exchange configuration between instruments or to modify the file content with an external program and reload them again.  
The filename is user-definable; the file extension is \*.pulstrn.
  - Using the corresponding remote-control commands.

Note that you have to create a pulse train file first.

- **Externally**

Create a pulse train sequence as a CSV file with Microsoft Excel, with a Notepad or a similar tool, save it with the predefined extension. Transfer the file to and load it into the instrument.

### Pulse train ASCII file format

Files describing pulse trains are simple files in text or comma-separated value (CSV) file format. The filename is user-definable; the file extension is `*.csv` or `*.txt`.

The file contains a list of pulse definition values, one row per pulse; a new line indicator separates the pulses. Pulses are defined with their pulse on time, pulse off time given in us and number of repetitions.

#### Example: Pulse train file content (\*.txt file)

```
0.0001,0.0005,2
0.00025,0.0005,1
0.0001,0.0003,3
```

For file handling, use the standard functions in the "File Manager", see [Chapter 11.8, "Using the File Manager"](#), on page 318.

### Settings

Pulse Train Data.....	105
Edit Pulse Train Data.....	106
Data handling keys .....	106
L Go To.....	106
L Edit.....	106
L Save As/Save.....	106
Fill.....	106

### Pulse Train Data

Accesses the standard "File Select" function of the instrument. The provided navigation possibilities in the dialog are self-explanatory.

Pulse train files are files with predefined file extension `*.pulstrn`. When a file is selected, the dialog indicates the filename.

You can create the file internally in the table editor or externally.

- To select an existing file, select "Select List > navigate to the file \*.pulstrn > Select"
- Use the general editor function to create internally new file or to edit an existing one.
- Use the standard file manager function to load externally created files to the instrument.

Remote command:

`[ :SOURce<hw> ] :PULM:TRAI:n:CATalog?` on page 570

`[ :SOURce<hw> ] :PULM:TRAI:n:SElect` on page 571

`[ :SOURce<hw> ] :PULM:TRAI:n:DElete` on page 570

**Edit Pulse Train Data**

Accesses the build-in table editor to define a new pulse train file or edit an existing one.

"On-Time,  $\mu$ s/Off-Time, $\mu$ s"

Sets the pulse on and pulse off time.

"Count"

Sets the number of repetitions of an "On-/ Off-Time" value pair.

Pulses with "Count = 0" are ignored.

Use this method to skip value pairs temporarily, without deleting them from the table.

Remote command:

[\[:SOURce<hw>\]:PULM:TRAI:n:ONTime](#) on page 570

[\[:SOURce<hw>\]:PULM:TRAI:n:OFFTime](#) on page 570

[\[:SOURce<hw>\]:PULM:TRAI:n:REPetition](#) on page 571

[\[:SOURce<hw>\]:PULM:TRAI:n:DELeTe](#) on page 570

**Data handling keys**

Standard functions for file and data handling.



**Note:** Save a list only after filling both columns (frequency and level), otherwise the entries are lost.

**Go To ← Data handling keys**

Selects a row for editing.

**Edit ← Data handling keys**

Enables you to insert, or delete a row or ranges within a list, and provides access to a dialog for automatic filling.

See " [Fill...](#) " on page 106.

**Save As/Save ← Data handling keys**

Saves the list in a file with user-defined name and predefined file extension. To save a copy or create a file, use the "Save as" function.

**Fill...**

Provides parameters for filling a table automatically with user-defined values.

From 0	Range 4
Column To Fill Frequency /Hz	
Start Value 2.000 000 000 000 GHz	End Value 2.600 000 000 000 GHz
Increment Value 200.000 000 000 MHz	
<input checked="" type="checkbox"/> Fill	

To fill the table, select "Fill".

**Note:** Once you enter a value or fill a column, the editor automatically adds preset values in the other columns. This functionality protects against data loss, otherwise incomplete rows will be lost when saving. You can simply override these values.

"From / Range"

Defines the start line and number of lines to be filled.

"Column To Fill"

Selects, if the column is filled up with frequencies in Hz, levels in dBm or dwell times in s.

"Start Value / End Value"

Sets the start value for frequency, level or dwell time. The end value is read only and depends on the increment value and the range.

"Increment Value"

Determines the step size.

"Fill"

Fills the column specified in "Column To fill".

#### 5.4.4.3 Import/Export List Files

Access:

- Select one of the following:
  - "Sweep" > "List mode".
  - "Level" > "User Correction".
  - "Modulation > Pulse Modulation > Pulse Generator > Pulse Mode = Train".

2. Select "Import/Export".

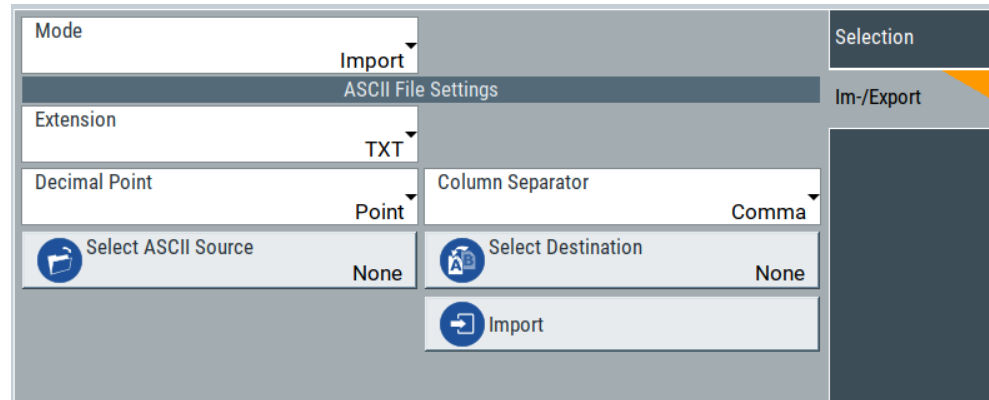

Figure 5-1: Im-/Export dialog (example with UCOR settings)

The "Import/Export" dialog contains all functions and settings to import externally created list data or to export it accordingly. You can process and store a list in the formats \*.txt (ASCII), or \*.csv (plain text with identical sequence of fields). The table separators and the decimal floating point numbers are customizable.

## Settings

Mode .....	108
ASCII File Settings.....	108
Select (ASCII) Source/Select (ASCII) Destination.....	109
Select Source/Select ASCII Destination.....	109
Import / Export.....	109

### Mode

Selects import or export of a data list file. The provided parameters vary according to the selected mode.

Remote command:

[ :SOURCE<hw> ] :LIST:DEXChange:MODE on page 657

[ :SOURCE<hw> ] :CORRection:DEXChange:MODE on page 624

[ :SOURCE<hw> ] :PULM:TRAIIn:DEXChange:MODE on page 572

### ASCII File Settings

Defines the format and the separators of the associated data file.

"Extension"      Selects \*.csv or \*.txt format.

"Decimal Point"      Sets "Point" (dot) or "Comma" as the decimal separator used in the ASCII data with floating-point numerals.

"Column Separator"      Sets the separator between the columns in an ASCII table.  
Available are: "Tab", "Semicolon", "Comma" or "Space".

Remote command:

[ :SOURCE<hw> ] :LIST:DEXChange:AFIle:EXTension on page 656

[ :SOURCE<hw> ] :LIST:DEXChange:AFIle:SEParator:DECimal on page 656



[\[:SOURCE<hw>\]:LIST:DEXChange:AFILe:SEParator:COLumn](#) on page 656

[\[:SOURCE<hw>\]:CORRection:DEXChange:AFILe:EXTension](#) on page 622

[\[:SOURCE<hw>\]:CORRection:DEXChange:AFILe:SEParator:DECimal](#)  
on page 623

[\[:SOURCE<hw>\]:CORRection:DEXChange:AFILe:SEParator:COLumn](#)  
on page 623

[\[:SOURCE<hw>\]:PULM:TRAIIn:DEXChange:AFILe:EXTension](#) on page 572

[\[:SOURCE<hw>\]:PULM:TRAIIn:DEXChange:AFILe:SEParator:DECimal](#)  
on page 573

[\[:SOURCE<hw>\]:PULM:TRAIIn:DEXChange:AFILe:SEParator:COLumn](#)  
on page 573

### Select (ASCII) Source/Select (ASCII) Destination

In "Mode > Import", access the file select dialog that provides standard file handling functions.

Where:

- "Select ASCII Source": defines the file to be loaded (imported)
- "Select ASCII Destination": selects the filename under that the loaded file is saved

Remote command:

[\[:SOURCE<hw>\]:LIST:DEXChange:AFILe:CATalog?](#) on page 655

[\[:SOURCE<hw>\]:LIST:DEXChange:AFILe:SElect](#) on page 656

[\[:SOURCE<hw>\]:CORRection:DEXChange:AFILe:CATalog?](#) on page 622

[\[:SOURCE<hw>\]:CORRection:DEXChange:AFILe:SElect](#) on page 623

[\[:SOURCE<hw>\]:PULM:TRAIIn:DEXChange:AFILe:CATalog?](#) on page 573

[\[:SOURCE<hw>\]:PULM:TRAIIn:DEXChange:AFILe:SElect](#) on page 573

### Select Source/Select ASCII Destination

In "Mode > Export", access the file select dialog that provides standard file handling functions.

Where:

- "Select Source": selects the file to be exported
- "Select ASCII Destination": defines the filename and the file path for the exported file

Remote command:

[\[:SOURCE<hw>\]:LIST:DEXChange:SElect](#) on page 657

[\[:SOURCE<hw>\]:CORRection:DEXChange:SElect](#) on page 624

[\[:SOURCE<hw>\]:PULM:TRAIIn:DEXChange:SElect](#) on page 574

### Import / Export

Imports or exports the selected data list file, depending on the current mode.

Remote command:

[\[:SOURCE<hw>\]:LIST:DEXChange:EXECute](#) on page 656

[\[:SOURCE<hw>\]:CORRection:DEXChange:EXECute](#) on page 623

[\[:SOURCE<hw>\]:PULM:TRAIIn:DEXChange:EXECute](#) on page 574

### 5.4.5 Pulse Graph

Option: see [Chapter 5.1, "Required Options"](#), on page 80.

Access:

- ▶ Select "Modulation" > "Pulse Modulation > Pulse Graph".

The pulse graph is the graphical representation of the current pulse signal.

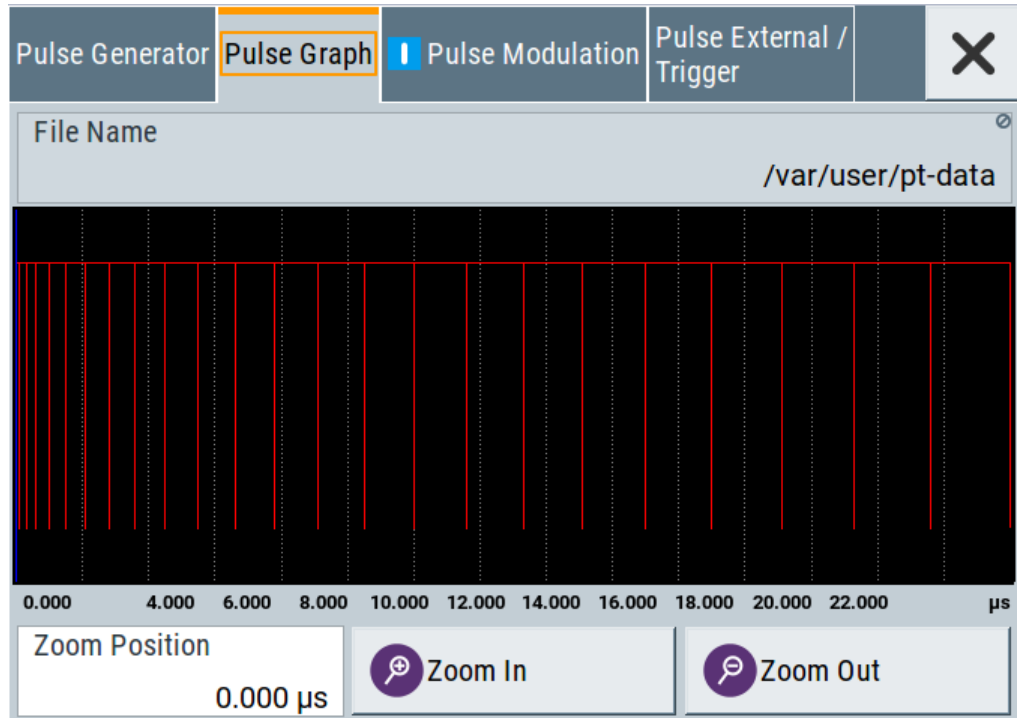

The height of the bars corresponds to the selected amplitude of the pulse signal.

#### File Name

Indicates the name of the pulse train data file.

To create or select a file, see ["Pulse Train Data"](#) on page 105.

Remote command:

`[ :SOURCE<hw> ] :PULM:TRAI:n:SElect` on page 571

#### Zooming

You can zoom into the diagram to visualize the graph in more detail:

- "Zoom Position": Sets the focus on the time axis where to enlarge the graph.
- "Zoom In": Enlarges the graph at the selected position.
- "Zoom Out" for the reverse operation.

## 5.4.6 Pulse External / Trigger Settings

Access:

- ▶ Select "Modulation" > "Pulse Modulation > Pulse External / Trigger".

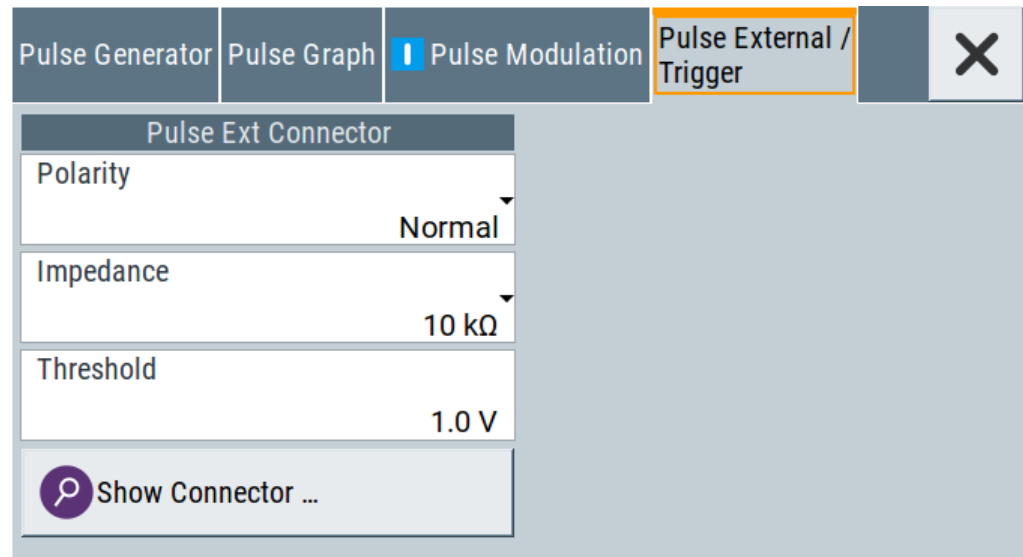

The dialog specifies some characteristics of the Pulse Ext connector. This connector is common for the pulse generator and the pulse modulator. For an overview, see ["Input and output connectors"](#) on page 81.

### Settings

<a href="#">Polarity</a> .....	111
<a href="#">Impedance</a> .....	111
<a href="#">Threshold</a> .....	111
<a href="#">Show Connector</a> .....	112

### Polarity

Sets the polarity of the active slope of a pulse input signal, that is the external pulse modulation signal.

Remote command:

`[ :SOURce<hw> ] :PULM:POLarity` on page 568

### Impedance

Sets the input impedance.

Remote command:

`[ :SOURce<hw> ] :PULM:IMPedance` on page 568

### Threshold

Sets the high/low threshold in volts for the signal at the [Pulse Ext] connector.

Remote command:

`[ :SOURce<hw> ] :PULM:THReshold` on page 568



**Show Connector**

Accesses a dialog that displays the physical location of the selected connector on the front/rear panel of the instrument.

**5.4.7 FM, PhiM and AM Modulation Sources**

Access:

- ▶ Select "Modulation > Modulation Sources".

In the "Sources" tab, you can configure an LF modulation signal for performing analog modulations. It includes the setting parameters of the internal LF-and multi-function generators, the noise generator, and an external signal source.

- [Source > LF Generator Settings](#)..... 112
- [Source > External Settings](#)..... 116
- [Source > Noise Generator Settings](#)..... 118

**5.4.7.1 Source > LF Generator Settings**

Access:

- ▶ Select "Modulation" > "Modulation Sources > LF Generator".

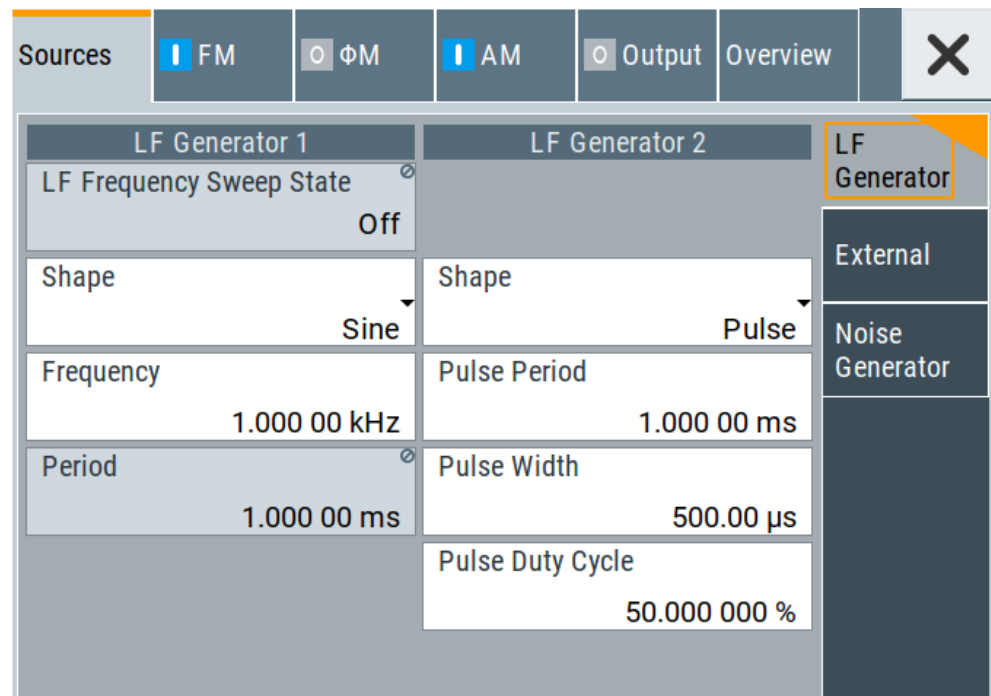

The internal LF signal can be the modulation signal source for any of the analog modulations. The LF signal applies to all modulations which use the internal modulation signal. Therefore, any modification of the LF signal immediately affects all currently active modulations.

### Settings

State (LF frequency sweep).....	113
Shape.....	113
Frequency.....	115
Period.....	115
Pulse Width.....	115
Pulse Duty Cycle.....	115
Triangle Rise.....	116
Trapezoid Rise / Fall.....	116
Trapezoid High.....	116

### State (LF frequency sweep)

Status of the LF frequency sweep signal.

You find this parameter in two dialogs:

- "LF Frequency Sweep" turns on/off the signal generation.  
See [Sweep Mode Settings](#) for access.
- "Analog Modulation Sources" displays the current state (read-only). If it is turned on, this dialog provides the varying sweep frequency, see [Current Frequency](#).

**Note:** Active RF frequency, RF level or RF combined sweep modes deactivate the LF sweep or List mode and vice versa.

Remote command:

[ :SOURce<hw> ] :LFOutput:FREQUENCY:MODE on page 636

### Shape

Selects the waveform shape of the LF generator signal.

The "Triangle" and "Trapezoid" waveforms require option R&S SMAB-K24.

"Sine"

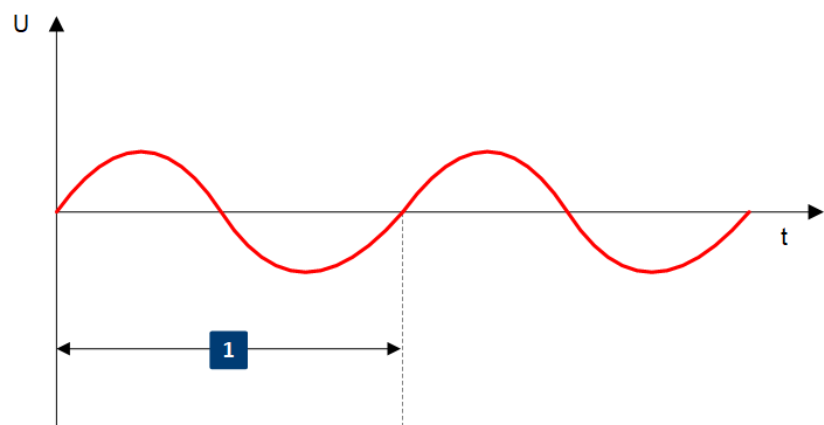

1 = Period

"Square"

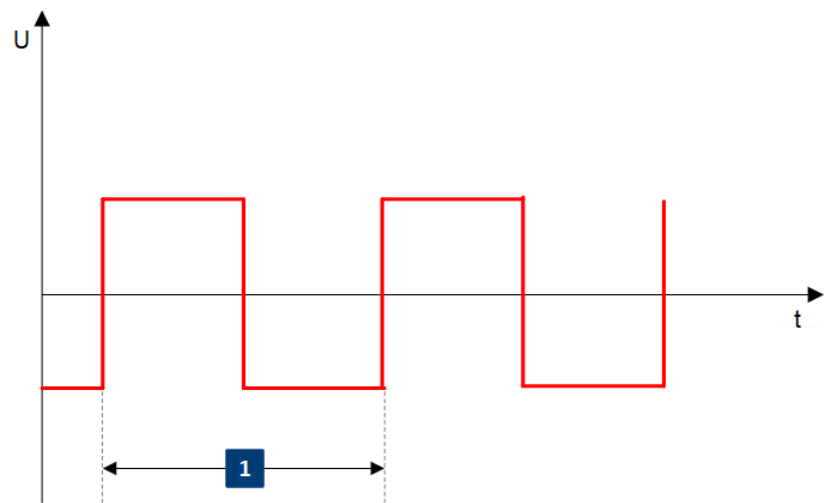

1 = Period

"Pulse"

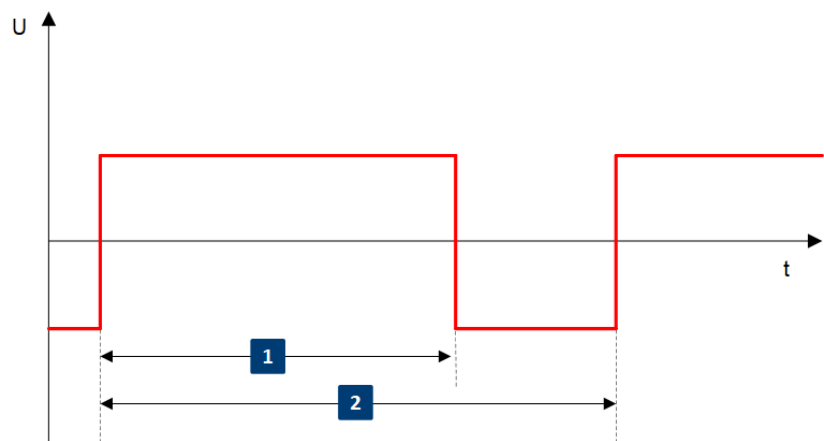
1 = Pulse width  
2 = Pulse period

"Triangle"

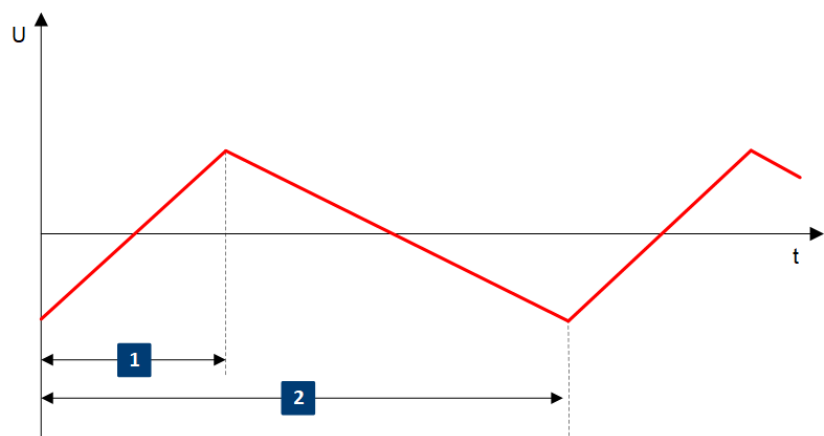
1 = Triangle rise  
2 = Triangle period

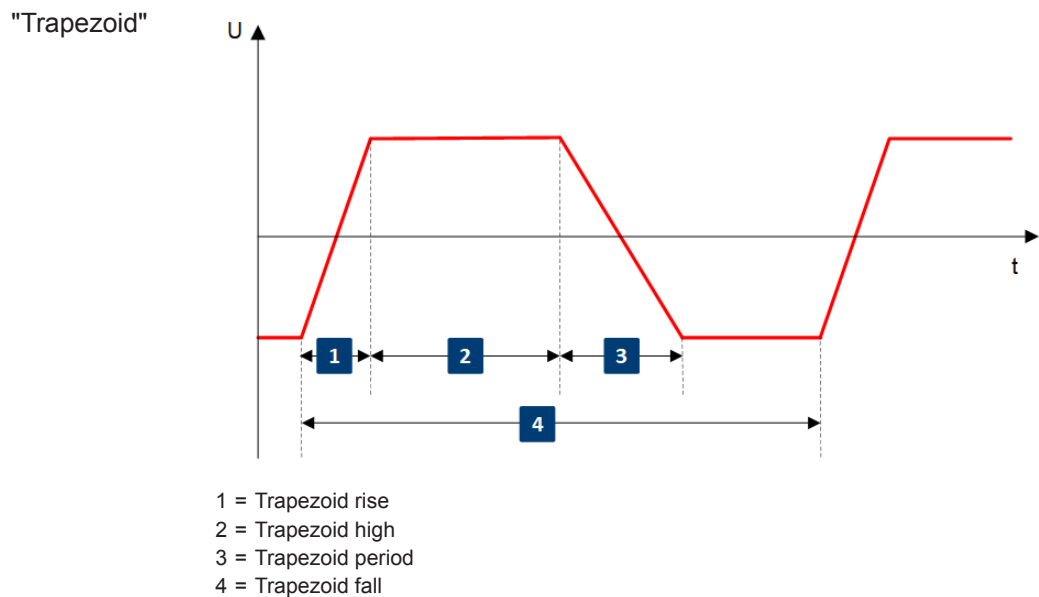

Remote command:

`[ :SOURce<hw> ] :LFOutput<ch> :SHAPE` on page 639

### Frequency

Sets the frequency of the LF generator for sine signals.

Set the signal shape with the parameter [Shape](#).

Remote command:

`[ :SOURce ] :LFOutput<ch> :FREQUENCY` on page 635

### Period

Sets the repetition rate of the generated LF signal for triangle, trapezoid or pulse shapes, see [Shape](#).

The period of sine signals is calculated from the selected [Frequency](#)

Remote command:

`[ :SOURce<hw> ] :LFOutput<ch> :SHAPE:TRAPeZe:PERiod` on page 640

`[ :SOURce<hw> ] :LFOutput<ch> :SHAPE:TRIangle:PERiod` on page 641

`[ :SOURce<hw> ] :LFOutput<ch> :SHAPE:PULSe:PERiod` on page 639

### Pulse Width

Sets the pulse duration of the generated pulse signal.

Remote command:

`[ :SOURce<hw> ] :LFOutput<ch> :SHAPE:PULSe:WIDTh` on page 640

### Pulse Duty Cycle

Sets the ratio between the pulse duration and the pulse period in percent.

Remote command:

`[ :SOURce<hw> ] :LFOutput<ch> :SHAPE:PULSe:DCYCLe` on page 639

**Triangle Rise**

Sets the time required for the triangle signal to change from low level to high level.

Remote command:

[\[:SOURce<hw>\]:LFOutput<ch>:SHAPE:TRIangle:RISE](#) on page 641

**Trapezoid Rise / Fall**

Sets the time required for the trapezoid signal to change from low level to high level, and vice versa.

Remote command:

[\[:SOURce<hw>\]:LFOutput<ch>:SHAPE:TRAPeZe:RISE](#) on page 641

[\[:SOURce<hw>\]:LFOutput<ch>:SHAPE:TRAPeZe:FALL](#) on page 640

**Trapezoid High**

Sets how long the trapezoid signal is at high level.

Remote command:

[\[:SOURce<hw>\]:LFOutput<ch>:SHAPE:TRAPeZe:HIGH](#) on page 640

**5.4.7.2 Source > External Settings**

Access:

- ▶ Select "Modulation" > "Modulation Sources > External".

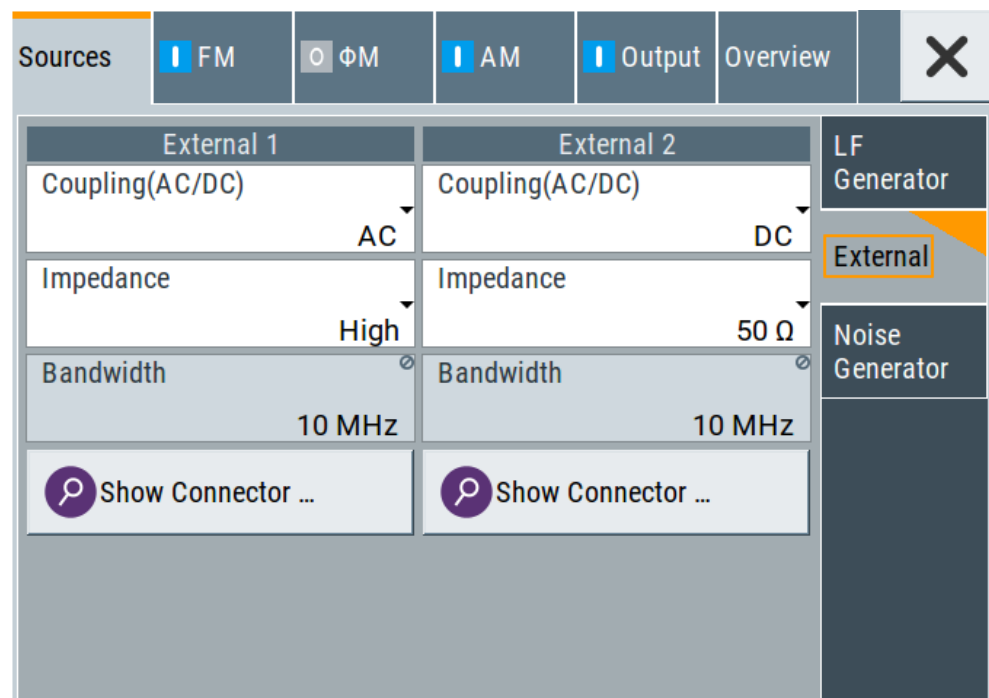

The "External" settings section contains all parameters required to configure the signal of an externally supplied LF signal.



**Settings**

Coupling (AC/DC).....	117
Impedance.....	117
Bandwidth.....	117
Show Connector.....	117

**Coupling (AC/DC)**

Selects the coupling mode (AC or DC) for the external signal.

- "AC"                    Disconnects the DC voltage component and uses only the AC component of the modulation signal.
- "DC"                    Uses the modulation signal with both components, AC and DC. For active external exponential AM, sets the coupling of the corresponding input automatically to DC.

Remote command:

[\[:SOURce<hw>\]:INPut:MODext:COUPling<ch>](#) on page 631

**Impedance**

Sets the impedance for the externally supplied signal.

Remote command:

[\[:SOURce<hw>\]:INPut:MODext:IMPedance<ch>](#) on page 632

**Bandwidth**

Displays the maximum bandwidth of the external LF signal.

Remote command:

[\[:SOURce\]:LFOutput<ch>:BANDwidth?](#) on page 635

**Show Connector**

Accesses a dialog that displays the physical location of the selected connector on the front/rear panel of the instrument.

### 5.4.7.3 Source > Noise Generator Settings

Access:

- ▶ Select "Modulation" > "Modulation Sources > Noise Generator".

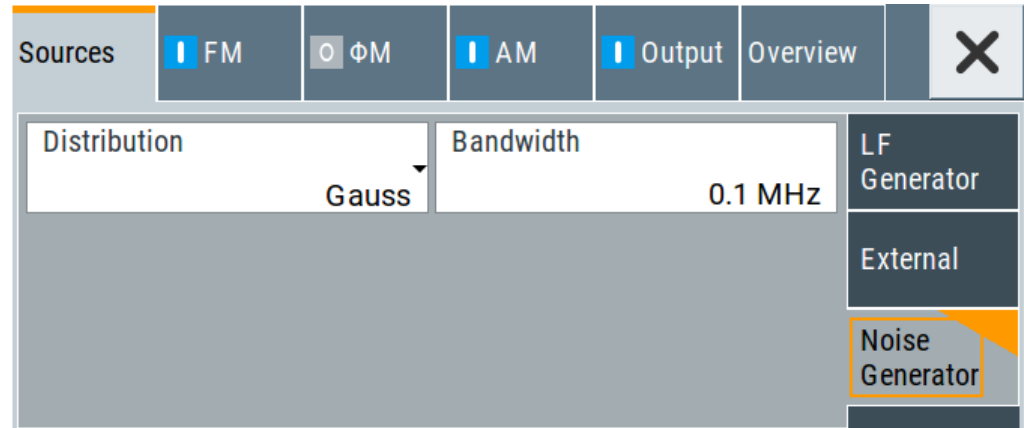

The "Noise Generator" settings contain all parameters to configure the signal of the internal noise generator.

#### Settings

<a href="#">Distribution</a> .....	118
<a href="#">Bandwidth</a> .....	118

#### Distribution

Selects the distribution of the noise power density.

"Gauss" Generates the noise power according to a Gaussian distribution.

"Equal" Generates an evenly distributed noise.

Remote command:

[\[:SOURce<hw>\]:NOISe:DISTRibution](#) on page 659

#### Bandwidth

Sets the noise bandwidth as distinct value.

You can set the bandwidth between 100 kHz and 10 MHz in 100 KHz steps.

Remote command:

[\[:SOURce<hw>\]:NOISe:BANDwidth|BWIDth](#) on page 658

[\[:SOURce<hw>\]:NOISe:BWIDth:STATe](#) on page 658

## 5.4.8 LF Signal Output Settings

Access:

- ▶ Select "Modulation" > "LF Output".

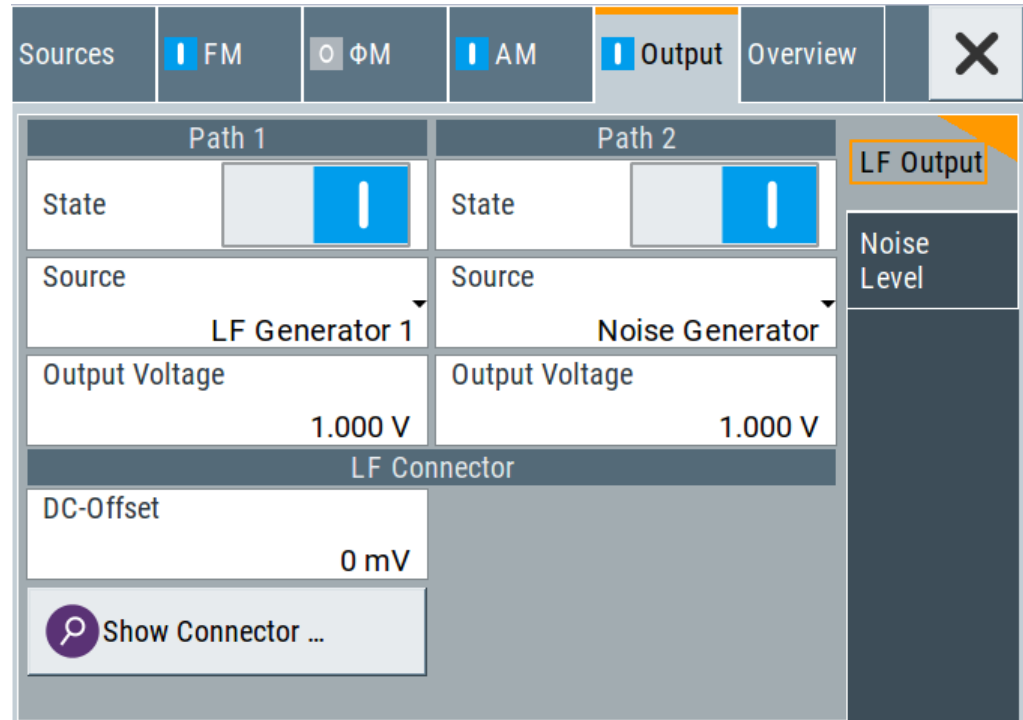

In the "LF Output" tab, you can configure the signal at the LF outputs, determine the output voltage or add a DC offset. Activate both paths to output the sum signal of the two sources.

### Settings:

State.....	119
Source.....	120
Show Connector.....	120
Output Voltage.....	120
DC-Offset.....	120
Load Impedance.....	120
Noise Level.....	121
└ Noise Density.....	121
└ Noise Level.....	121

### State

Activates the output of the LF signal.

Remote command:

[ :SOURce ] :LFOutput<ch> [ :STATe ] on page 637

**Source**

Select the sources for the signal output at the LF connector. If you activate path 1 *and* 2, those sources are added.

Use the "Show Connector" function to find out where this connector is located.

"LF Generator 1/2"

Selects one of internally generated LF signals.

"AM"

Option: R&S SMAB-K720

Selects the AM signal.

"FM/PhiM"

Option: R&S SMAB-K720

Selects the signal also used by the frequency or phase modulations.

"Noise Generator"

Selects the internally generated noise signal.

"External 1/2"

Selects one of the externally supplied LF signals.

Remote command:

[\[:SOURce\]:LFOutput<ch>:SOURce](#) on page 638

**Show Connector**

Accesses a dialog that displays the physical location of the selected connector on the front/rear panel of the instrument.

**Output Voltage**

Sets the peak to peak voltage of the selected LF output source.

This value, e.g. +1 V to -1 V refers to 50 Ohm at the RF output with high termination impedance at the LF output.

Remote command:

[\[:SOURce\]:LFOutput<ch>:INTernal:VOLTage](#) on page 637

**DC-Offset**

Adds a DC offset to the LF output signal.

Remote command:

[\[:SOURce\]:LFOutput:OFFSet](#) on page 638

**Load Impedance**

Sets the specification of the load impedance interconnected to the LF generator output.

This parameter is available in case of activated R&S SML0x emulations only, see "Remote Access Settings" > "Instrument Emulations" > "[Language](#)" on page 388.

These signal generators come with an LF generator source impedance of 10 Ohm which is not available with the R&S SMA100B.

The set LF generator load impedance enables the R&S SMA100B to emulate the 10 Ohm LF generator source impedance of these generators by a corresponding increase of the open circuit LF generator output voltage.

The load impedance setting is not affected by an instrument preset ([Preset] key or \*RST), restart or the "Save/Recall" function. It is reset to the default value of 1 MOhm by a factory preset only.

Remote command:  
n.a.

### Noise Level

Access:

- Select "Modulation" > "Output > Noise Level".

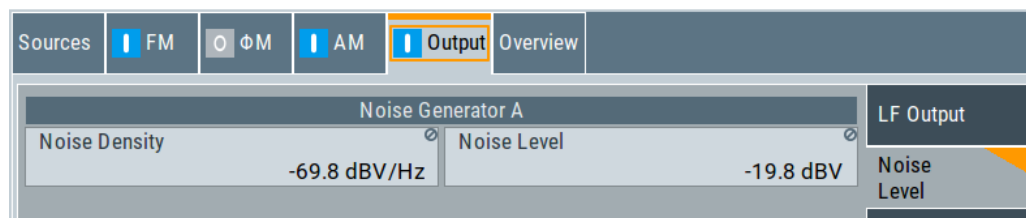

### Noise Density ← Noise Level

Indicates the level of the noise signal for a bandwidth of 1 Hz (relative).

Remote command:

[\[:SOURCE<hw>\]:NOISE:LEVEL:RELATIVE?](#) on page 659

### Noise Level ← Noise Level

Indicates the level of the noise signal per Hz within the total bandwidth (absolute).

Remote command:

[\[:SOURCE<hw>\]:NOISE:LEVEL\[:ABSOLUTE\]?](#) on page 659

## 5.4.9 Overview

Option: AM and FM/PM require R&S SMAB-K720

Access:

- ▶ Select "Modulation" > "Modulation Sources > Overview".

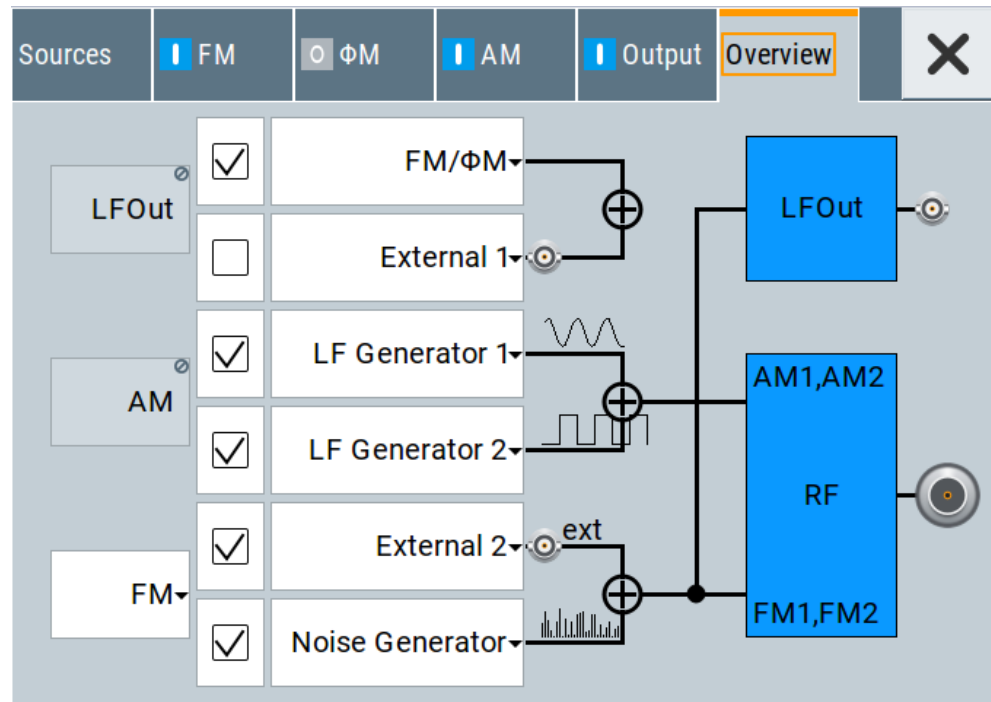

- Blue color = Active output signal (AM and FM)
- Gray color = Inactive output signal (LF Out)
- Miniature graph = Indicates an active source
- Connectors = Indicate a connector (e.g. external signal) is involved in the path of the signal

The "Overview" tab is an interactive diagram that indicates the active modulations and the signal being output.

Here you can:

- Select the output signal ("LF Out") in one or two paths; the setting acts as the parameter "LF Output Source"
- Select the source for each modulation and modulation path; the setting acts as the parameter "Source"
- Activate modulation in one or two paths; the setting acts as the parameter "State"  
To generate a two-tone signal composed form the two paths of the same modulation type, activate both paths.
- The "FM" box allows switching to "PhiM", but those modulations are mutually exclusive.

#### LFOut

Label for the LF output settings in the overview.

Remote command:

n.a.

**AM**

Label for the amplitude modulation settings in the overview.

Remote command:

n.a.

**FM/PhiM**

Selects the modulation signal to be assigned to the output. You can assign the frequency or phase modulated signal.

Remote command:

n.a.

## 5.5 How to Generate an Amplitude Modulated Signal

The following examples use the internal LF generator.

**To set the frequency and level of the RF signal**

1. Press [Preset] to start from a defined state.
2. In the status bar, set "Frequency = 2 GHz".
3. Set "Level = -20 dBm".

**To configure the modulation signal (LF generator)**

1. Select "Modulation" > "Modulation Source".
2. In the "Sources" tab, select "Shape > Sine".
3. Set "Frequency = 20 kHz".

The period is calculated automatically and indicates "Period = 50.00 µs".

**To configure the amplitude modulation settings**

1. In "Modulation" dialog, select the "AM" tab.
2. Set "Source = LF Generator1"
3. Set "Depth = 30%"
4. Select "State = I" to activate the modulation.
5. Set "Level > RF ON" to enable signal output.

## 5.6 How to Generate a Pulse Modulated Signal

The following example uses the internal pulse generator.

**To set the frequency and level of the RF signal**

1. Press [Preset].
2. In the status bar, set "Frequency = 4 GHz".
3. Set "Level = -25 dBm".

**To configure the pulse generator**

1. Select "Modulation" > "Pulse Generator".
2. Select "Pulse Mode = Double".
3. Set "Pulse Period = 10 us".
4. Set "Pulse Width = 2 us".
5. Set "Double Pulse Width = 1.2 us".
6. Set "Double Pulse Delay = 4.5 us".
7. Activate "Pulse Output State".
8. Set "Trigger Mode = Auto".

In the "Pulse Graph" tab, you can view the generated pulse signal graphically.

**To enable pulse modulation**

1. Select the "Pulse Modulation" tab.
2. Set "State = I" to activate pulse modulation.
3. Set "Level > RF ON" to enable signal output.

## 5.7 How to Generate a Pulse Train Modulated Signal

The following example uses the internal pulse generator.

**To set the frequency and level of the RF signal**

1. Press [Preset].
2. In the status bar, set "Frequency = 6 GHz".
3. Set "Level = -25 dBm".

**To configure the pulse generator**

1. Select "Modulation" > "Pulse Generator".
2. Select "Pulse Mode = Train".
3. Select "Pulse Train Data".  
Accesses the standard function for file handling.



4. Select an existing file or select "New" to create one.
5. Define the filename.  
Select "Edit Pulse Train Data", if the file is empty or to control and change the values.
6. In the "Edit Pulse Train Data" dialog, enter the pulse on/off times and pulse repetition values.  
For example:
  - "On-Time = 500 us", "OFF-Time = 2 ms", "Count = 2"
  - "On-Time = 100 us", "OFF-Time = 2.5 ms", "Count = 1"
  - "On-Time = 10 us", "OFF-Time = 50 us", "Count = 10"
7. "Save" the file and close the dialog.  
The instrument returns to the /var/user/ where it has saved the file.
8. Select the file in the directory.
9. Confirm with "Select".
10. In the "Pulse Generator" dialog, select "Pulse Output State = On".
11. Set "Trigger Mode = Auto".

In the "Pulse Graph" tab, you can view the generated pulse signal graphically.

#### **To enable pulse train modulation**

1. Select the "Pulse Modulation" tab.
2. Set "State = I".
3. Set "Level > RF ON" to enable signal output.

## 6 Avionic Standards

The R&S SMA100B supports avionic standards VOR, ILS and ADF.

### Contents

• <a href="#">Required Options</a> .....	126
• <a href="#">About the Avionics Options</a> .....	126
• <a href="#">VOR Configuration and Settings</a> .....	132
• <a href="#">ILS Configuration and Settings</a> .....	140
• <a href="#">ADF Configuration and Settings</a> .....	163

### 6.1 Required Options

The R&S SMA100B base unit equipped with the following options:

- Option frequency (R&S SMAB-B10x)
- Option signal generation for VOR, ILS and ADF (R&S SMAB-K25)

### 6.2 About the Avionics Options

The following topics summarize some background information on the related avionics standards. The provided overview information is intended as explanation of the used terms and does not aim to be comprehensive.

#### Brief overview of the avionics standards

- **Landing systems:** ILS (Instrument Landing System), MLS (Microwave Landing System)  
Landing systems are ground-based approach systems that provide precision guidance to an aircraft approaching and (blind) landing on a runway.
- **Radio/Flight navigation systems:** VOR (VHF Omnidirectional Radio), DME (Distance measuring equipment), TACAN (Tactical Air Navigation), ADF (Automatic Direction Finder)  
The radio navigation systems are aircraft systems that support the pilots to determine the aircraft positions and stay on course. These systems are more and more obsolete. However, due to security reasons, these flight navigation systems are still in use.
- **Radar systems:** RSR (En Route Surveillance Radar), ASR (Airport Surveillance Radar), PAR (Precision Approach Radar), ASDE (Airport Surface Detection Equipment), SSR (Secondary Surveillance Radar)  
Radar systems are divided into two groups, primary (RSR, ASR, PAR and ASDE) and secondary (SSR). The radar systems are used in air traffic control to mainly detect and measure the position of aircraft, i.e. its range and bearing.

## 6.2.1 VHF Omni Directional Radio Range (VOR)

Very high frequency (VHF) omnidirectional radio range (VOR) is used for radio navigation and helps aircraft to determine their position and stay on course.

A VOR system consists of a ground transmission station and a VOR receiver on the board of the aircraft.

The transmitter stations operate at VHF frequencies of 108 MHz to 118 MHz (see [Table 6-1](#)), with the code identification (COM/ID) transmitting on a modulation tone of 1.020 kHz. It emits two types of signals:

- An omnidirectional reference signal (REF) that can consist of two parts:
  - 30 Hz frequency modulated (FM) sine wave on subcarrier 9.96 kHz from amplitude modulation (AM) carrier
  - 1020 Hz AM modulated sine wave morse code
- A directional positioning signal, variable (VAR): 30 Hz AM modulated sine waves with variable phase shift

The position of the aircraft is determined by measuring azimuth as the difference in phase of those two signals. The magnetic north is defined as the reference point, for which both signals are exactly in phase.

### VOR ICAO Frequencies

The individual values in the table below are:

- **Chan.** = ICAO channel number
- **VOR Freq.** = VOR Interrogation frequency (MHz)

**Table 6-1: VOR ICAO standard frequencies (MHz) and channels**

Chan.	VOR Freq.	Chan.	VOR Freq.	Chan.	VOR Freq.	Chan.	VOR Freq.	Chan.	VOR Freq.	Chan.	VOR Freq.
17X	108.00	45X	110.80	75X	112.80	89X	114.20	103X	115.60	117X	117.00
17Y	108.05	45Y	110.85	75Y	112.85	89Y	114.25	103Y	115.65	117Y	117.05
19X	108.20	47X	111.00	76X	112.90	90X	114.30	104X	115.70	118X	117.10
19Y	108.25	47Y	111.05	76Y	112.95	90Y	114.35	104Y	115.75	118Y	117.15
21X	108.40	49X	111.20	77X	113.00	91X	114.40	105X	115.80	119X	117.20
21Y	108.45	49Y	111.25	77Y	113.05	91Y	114.45	105Y	115.85	119Y	117.25
23X	108.60	51X	111.40	78X	113.10	92X	114.50	106X	115.90	120X	117.30
23Y	108.65	51Y	111.45	78Y	113.15	92Y	114.55	106Y	115.95	120Y	117.35
25X	108.80	53X	111.60	79X	113.20	93X	114.60	107X	116.00	121X	117.40
25Y	108.85	53Y	111.65	79Y	113.25	93Y	114.65	107Y	116.05	121Y	117.45
27X	109.00	55X	111.80	80X	113.30	94X	114.70	108X	116.10	122X	117.50
27Y	109.05	55Y	111.85	80Y	113.35	94Y	114.75	108Y	116.15	122Y	117.55
29X	109.20	57X	112.00	81X	113.40	95X	114.80	109X	116.20	123X	117.60
29Y	109.25	57Y	112.05	81Y	113.45	95Y	114.85	109Y	116.25	123Y	117.65
31X	109.40	58X	112.10	82X	113.50	96X	114.90	110X	116.30	124X	117.70
31Y	109.45	58Y	112.15	82Y	113.55	96Y	114.95	110Y	116.35	124Y	117.75

Chan.	VOR Freq.	Chan.	VOR Freq.	Chan.	VOR Freq.	Chan.	VOR Freq.	Chan.	VOR Freq.	Chan.	VOR Freq.
33X	109.60	59X	112.20	83X	113.60	97X	115.00	111X	116.40	125X	117.80
33Y	109.65	59Y	112.25	83Y	113.65	97Y	115.05	111Y	116.45	125Y	117.85
35X	109.80	70X	112.30	84X	113.70	98X	115.10	112X	116.50	126X	117.90
35Y	109.85	70Y	112.35	84Y	113.75	98Y	115.15	112Y	116.55	126Y	117.95
37X	110.00	71X	112.40	85X	113.80	99X	115.20	113X	116.60		
37Y	110.05	71Y	112.45	85Y	113.85	99Y	115.25	113Y	116.65		
39X	110.20	72X	112.50	86X	113.90	100X	115.30	114X	116.75		
39Y	110.25	72Y	112.55	86Y	113.95	100Y	115.35	114Y	116.75		
41X	110.40	73X	112.60	87Y	114.00	101X	115.40	115X	116.80		
41Y	110.45	73Y	112.65	87Y	114.05	101Y	115.45	115Y	116.85		
43X	110.60	74X	112.70	88X	114.10	102X	115.50	116X	116.90		
43Y	110.65	74Y	112.75	88Y	114.15	102Y	115.55	116Y	116.95		

### Related Settings

For VOR settings at the R&S SMA100B, see [Chapter 6.3, "VOR Configuration and Settings"](#), on page 132.

## 6.2.2 Instrument Landing System (ILS)

The instrument landing system is used during the landing approach and monitors the correct approach path to the runway.

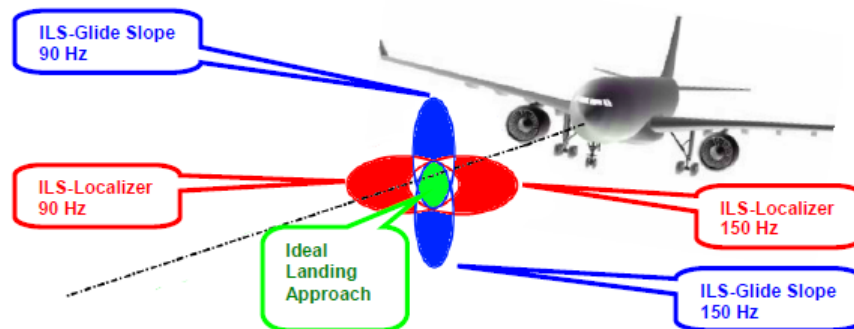

**Figure 6-1: Approach navigation using instrument landing system (ILS) [1MA193]**

An ILS system consists of three independent subsystems:

- A glide slope for vertical guidance.
- A localizer for horizontal guidance.
- (optional) marker beacons

### Glide Slope

The glide slope transmitter is located near the end of the runway (nearest to the start of the aircraft approach).

Typically, vertically aligned antennas transmit two intersecting main beams on top of one another at carrier frequencies between 329 MHz and 335 MHz (see [Table 6-2](#)). The top beam is usually modulated at 90 Hz and the beam below at 150 Hz [1MA193].

The information on position is provided after demodulation of the beam signals by evaluating the difference in depth of modulation (DDM). The following scenarios are possible:

- Predominance of the 90 Hz beam: the aircraft is too high and must descend
- Predominance of the 150 Hz beam: the aircraft is too low and needs to climb
- The signal strength from both beams is equal: the aircraft is in the center, on the right course.

If there is a predominance of the 90 Hz beam, then the aircraft is too high and must descend. A predominant 150 Hz means that the aircraft is too low and needs to climb.

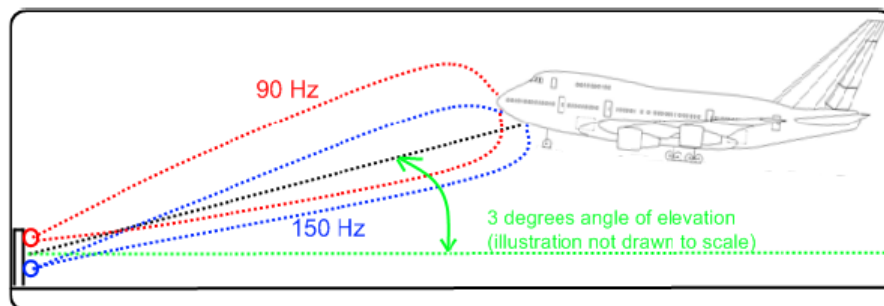

### Localizer

The localizer transmitter is located near the end of the runway (nearest to the start of the aircraft approach). Typically, horizontally aligned antennas transmit two intersecting main beams beside one another at carrier frequencies between 108 MHz and 112 MHz (see [Table 6-2](#)). As seen from the approaching aircraft coming in for a landing, the left beam is usually modulated at 90 Hz and the right beam at 150 Hz [1MA193].

The information on position is provided after demodulation of the beam signals by evaluating the difference in depth of modulation (DDM). The following scenarios are possible:

- Predominance of the 90 Hz beam: the aircraft is too far to the left and must turn to the right
- Predominance of the 150 Hz beam: the aircraft is too far to the right and must turn to the left
- The signal strength from both beams is equal: the aircraft is in the center, on the right course.

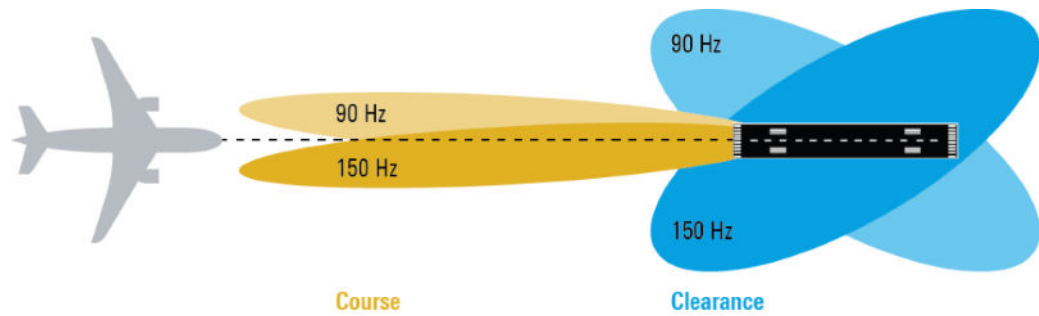

### ILS ICAO Frequencies

The individual values in the table below are:

- **Chan.** = ICAO channel number
- **LOC Freq.** = ILS localizer frequency (MHz)
- **GS Freq.** = ILS glide slope frequency (MHz)

*Table 6-2: ILS glide slope and localizer ICAO standard frequencies (MHz) and channels*

Chan.	LOC Freq.	GS Freq.	Chan.	LOC Freq.	GS Freq.	Chan.	LOC Freq.	GS Freq.
18X	108.10	334.70	32X	109.50	332.60	46X	110.90	330.80
18Y	108.15	334.55	32Y	109.55	332.45	46Y	110.95	330.65
20X	108.30	334.10	34X	109.70	333.20	48X	111.10	331.70
20Y	108.35	333.95	34Y	109.75	333.05	48Y	111.15	331.55
22X	108.50	329.90	36X	109.90	333.80	50X	111.30	332.30
22Y	108.55	329.75	36Y	109.95	333.65	50Y	111.35	332.15
24X	108.70	330.50	38X	110.10	334.40	52X	111.50	332.90
24Y	108.75	330.35	38Y	110.15	334.25	52Y	111.55	332.75
26X	108.90	329.30	40X	110.30	335.00	54X	111.70	333.50
26Y	108.95	329.15	40Y	110.35	334.85	54Y	111.75	333.35
28X	109.10	331.40	42X	110.50	329.60	56X	111.90	331.10
28Y	109.15	331.25	42Y	110.55	329.45	56Y	111.95	330.95
30X	109.30	332.00	44X	110.70	330.20			
30Y	109.35	331.85	44Y	110.75	330.05			

### Marker Beacons

Marker beacon receivers are used for a rough distance measurement. They are available only for some ILS installations [1MA193].

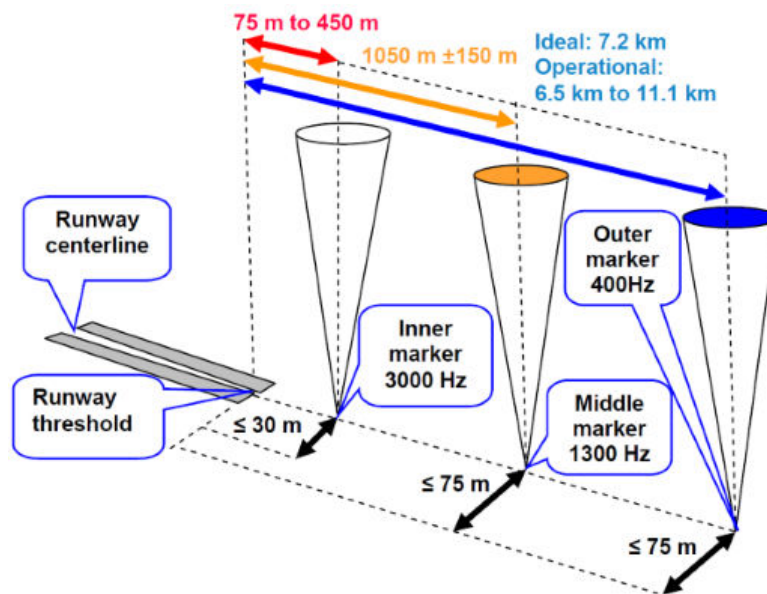

Figure 6-2: Marker beacon placement and distance to runway

Marker beacon receivers decode audio and provide signaling output to identify one of three marker beacons installed near the runway. They transmit a narrow beam width at 75 MHz carrier frequency in a vertical direction. Each of them has a different distinct modulation code to allow the receiver to identify which one it is flying over [1MA193].

Both visual (color of the marker beacon) and audio tone identification is supported for determining which marker has been flown over. The audio/visual pairing of marker beacons is as follows:

- Outer marker flashes BLUE in the cockpit at 400 Hz (“relaxed” tone).
- Middle marker flashes AMBER in the cockpit at 1300 Hz (“hurried” tone).
- Inner marker flashes WHITE in the cockpit at 3000 Hz (“urgent” tone).

### Related Settings

For ILS settings at the R&S SMA100B, see the following sections:

- [Chapter 6.4.2, "ILS Glide Slope Settings"](#), on page 143
- [Chapter 6.4.3, "ILS Localizer Settings"](#), on page 149
- [Chapter 6.4.4, "ILS Marker Beacons Settings"](#), on page 158

## 6.2.3 Automatic Direction Finder (ADF)

ADF receivers provide the relative bearing of a basic ground-based Non-Directional Beacon (NDB) to the fore/aft axis of the aircraft. The beacon signal is generated by a directional antenna assembly in the aircraft.

The ADF determines the direction to the NDB station relative to the aircraft and is used for instrument approaches (autopilot). It provides additional information to other navigation equipment, e.g. VOR.

**Related Settings**

For ADF settings at the R&S SMA100B, see [Chapter 6.5, "ADF Configuration and Settings"](#), on page 163.

**6.3 VOR Configuration and Settings**

Option: R&S SMAB-K25

Access:

- ▶ Select "Modulation > Avionic Standards > VOR".

The remote commands required to define VOR settings are described in [Chapter 14.16.2.5, "SOURCE:VOR Subsystem"](#), on page 607.

**Settings**

- [General Settings](#)..... 132
- [Signal Settings](#)..... 135
- [Position Settings](#)..... 137
- [COM/ID Settings](#)..... 138

**6.3.1 General Settings**

Access:

- ▶ Select "VOR > General"

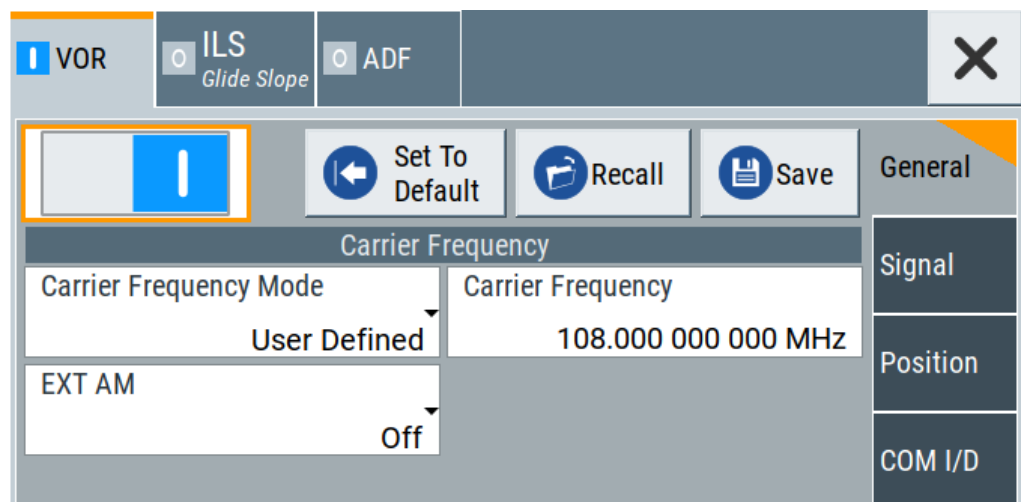

This dialog comprises general settings of the VOR standard, the default and the "Save/Recall" settings.



By default, a VOR modulation signal is set on an RF carrier with a frequency of 108 MHz or ICAO channel 17X. The 9.96 kHz subcarrier signal is frequency modulated with a 30.00 Hz reference signal. The COM/ID signal has 1.02 kHz frequency, the variable phase signal 30.00 Hz frequency.

If enabled, the avionic standard modulation is displayed in the "Modulation" tile as follows:

- "Avionic: VOR" for enabled VOR modulation
- "Avionic ILS: Glide Slope/Localizer/Marker Bcn" for enabled ILS glide slope/localizer/marker beacons modulation
- "Avionic: ADF" for enabled ADF modulation

Changing a parameter in the avionic standards causes an instant signal change in the R&S SMA100B. There is no extra measurement cycle to calculate the RMS value of the baseband signal to set the correct RF level.

If the avionics standard is activated for the first time, or after every subsequent on/off sequence, the measurement cycle will take place to determine the correct RF level. Every subsequent parameter change in the avionic standard is performed without another measurement cycle to provide a continuous signal output.

## Settings

State.....	133
Set To Default.....	133
Save/Recall.....	134
Carrier Frequency Mode.....	134
Carrier Frequency.....	134
ICAO Channel.....	134
EXT AM.....	135

## State

Activates the avionic standard.

Activation of the standard deactivates a previously active avionic standard. The "VOR/ILS > Carrier Frequency" setting is applied automatically to the RF [Frequency](#) and displayed in the status bar.

Remote command:

[<subsystem>:STATE](#) on page 581

## Set To Default

Calls the default settings. The values of the main parameters are listed in the following table.

Standard	Parameter	Value
VOR/ILS/ADF	State	Not affected by "Set to default"
VOR	Carrier Frequency Mode	User Defined
	Carrier Frequency	108.000000 MHz
ILS	ILS Component	Glide Slope (GS)
	ILS GS > Carrier Frequency Mode	User Defined

Standard	Parameter	Value
	ILS GS > Carrier Frequency	334.700000 MHz
ADF	Carrier Frequency	190.000 kHz

Remote command:

[<subsystem>:PRESet](#) on page 579

### Save/Recall

Accesses the "Save/Recall" dialog, that is the standard instrument function for saving and recalling the complete dialog-related settings in a file. The provided navigation possibilities in the dialog are self-explanatory.

The filename and the directory, in that the settings are stored, are user-definable; the file extension is however predefined.

Remote command:

[<subsystem>:SETTing:CATalog](#) on page 580

[<subsystem>:SETTing:DELeTe](#) on page 580

[<subsystem>:SETTing:LOAD](#) on page 580

[<subsystem>:SETTing:STORe](#) on page 581

### Carrier Frequency Mode

Sets the mode for the carrier frequency of the signal.

"User Defined" Activates user-defined variation of the carrier frequency.

"ICAO" Activates variation in predefined steps according to standard VOR transmitting frequencies (see [Table 6-1](#)). The start value can be selected in the field "ICAO Channel".

Remote command:

[\[:SOURce<hw>\]:VOR:FREQuency:MODE](#) on page 613

### Carrier Frequency

Requires "Carrier Frequency Mode > User Defined".

Sets the carrier frequency of the signal.

Remote command:

[\[:SOURce<hw>\]:VOR:FREQuency](#) on page 612

### ICAO Channel

Requires "Carrier Frequency Mode > ICAO".

Sets the ICAO channel and the corresponding transmitting frequency.

If avionic standard modulation is activated and you change the "RF Frequency", the frequency value of the closest ICAO channel is applied automatically. The "ICAO Channel" is also updated.

For an overview of the VOR ICAO channel frequencies, see [Table 6-1](#).

Remote command:

[\[:SOURce<hw>\]:VOR:ICAO:CHANnel](#) on page 613

**EXT AM**

Enables/disables additional modulation from an external source. The external signal is input via the Ext connector.

"Off" Selects the internal modulation source for the avionic standard modulation.

"EXT (MOD AM)" Selects the external source. The external signal is added to the internal signal. Switching off the internal source is not possible. The external signal is input via the Ext connector. The sensitivity is 10 mV per percent modulation depth.

**Note:** There can be an overmodulation as a function of the level of the external signal without a corresponding caution message being generated. To avoid an overmodulation, the peak value of the external signal is to be delimited corresponding to the sum of the modulation depths of the remaining VOR signal components.

Remote command:

[ :SOURce<hw> ] :VOR:SOURce on page 608

**6.3.2 Signal Settings**

Access:

- ▶ Select "VOR > Signal".

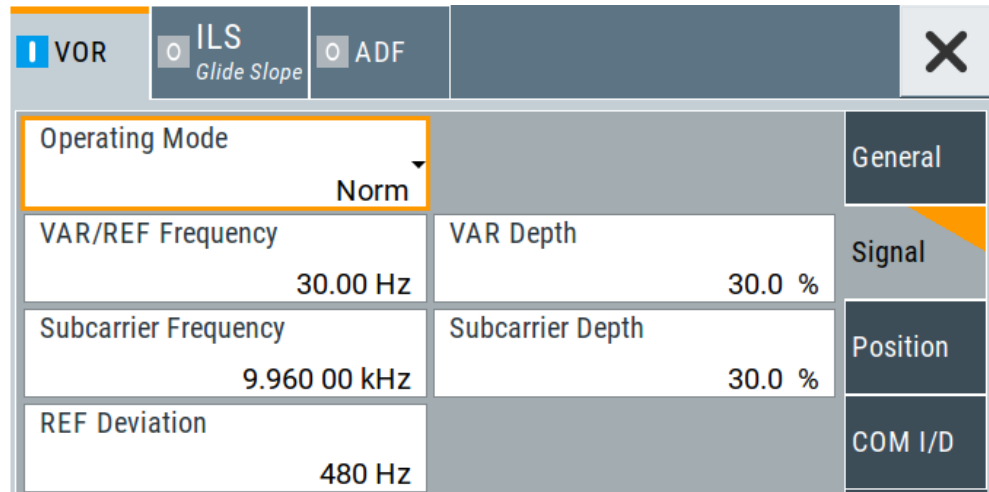

This dialog provides access to signal settings of the VOR modulation signal.

**Settings**

Mode..... 136

VAR/REF Frequency..... 136

VAR Depth..... 136

Subcarrier Frequency.....	136
Subcarrier Depth .....	136
REF Deviation.....	137

### Mode

Selects the operating mode for the VOR modulation signal.

"Norm"	VOR modulation is active.
"Var"	Amplitude modulation of the output signal with the VAR signal component (30Hz signal content) of the VOR signal. The modulation depth corresponds to the value set under <a href="#">VAR Depth</a> .
"Subcarrier"	Amplitude modulation of the output signal with the unmodulated FM carrier (9960Hz) of the VOR signal. The modulation depth corresponds to the value set under <a href="#">Subcarrier Depth</a> .
"Subcarrier + FM"	Amplitude modulation of the output signal with the frequency-modulated FM carrier (9960Hz) of the VOR signal. The frequency deviation corresponds to the value set under <a href="#">REF Deviation</a> , the modulation depth corresponds to the value set under "Subcarrier Depth".

Remote command:

`[ :SOURCE<hw> ] :VOR:MODE` on page 614

### VAR/REF Frequency

Sets the frequency of the VAR signal and the REF signal. As the two signals must have the same frequency, the setting is valid for both signals.

Remote command:

`[ :SOURCE<hw> ] :VOR:VAR:FREQUENCY` on page 616

### VAR Depth

Sets the AM modulation depth of the 30Hz VAR signal.

**Note:** The sum of "Subcarrier depth", "VAR depth" and "COM/ID > Depth" must be smaller than 100 %.

Remote command:

`[ :SOURCE<hw> ] :VOR:VAR[:DEPTH]` on page 616

### Subcarrier Frequency

Sets the frequency of the FM carrier.

Remote command:

`[ :SOURCE<hw> ] :VOR:SUBCarrier[:FREQUENCY]` on page 615

### Subcarrier Depth

Sets the AM modulation depth of the FM carrier.

**Note:** The sum of "Subcarrier depth", "VAR depth" and "COM/ID > Depth" must be smaller than 100 %.

Remote command:

`[ :SOURCE<hw> ] :VOR:SUBCarrier:DEPTH` on page 615

**REF Deviation**

Sets the frequency deviation of the reference signal on the FM carrier.

Remote command:

[\[:SOURce<hw>\]:VOR:REFerence\[:DEViation\]](#) on page 615

**6.3.3 Position Settings**

Access:

- ▶ Select "VOR > Position".

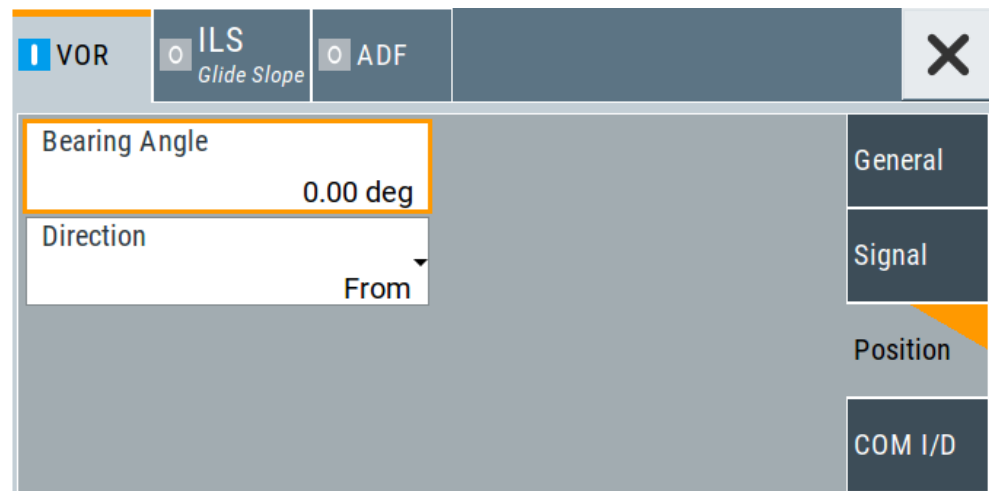

This dialog provides access to position settings related to the VOR modulation signal.

**Settings**

<a href="#">Bearing Angle</a> .....	137
<a href="#">Direction</a> .....	137

**Bearing Angle**

Sets the phase angle between the 30 Hz VAR signal and the 30 Hz reference signal. The orientation of the angle depends on the set [Direction](#).

Remote command:

[\[:SOURce<hw>\]:VOR\[:BANgLe\]](#) on page 608

**Direction**

Sets the reference position of the phase information.

The angle set under "Bearing Angle" corresponds to the angle between the geographic north and the connection line from beacon to airplane.

"From"                      Selection of the beacon as a reference position.

"To"                              Selection of the airplane position as a reference position.

Remote command:

[ :SOURce<hw> ] :VOR [ :BANGLE ] :DIRection on page 609

### 6.3.4 COM/ID Settings

Access:

- ▶ Select "VOR > COM/ID"

VOR		ILS <i>Glide Slope</i>	ADF	
COM/ID State <input type="checkbox"/>				General
Code	MUC	Period	9.000 s	Signal
Frequency	1.020 00 kHz	Depth	10.0 %	Position
Time Schema	Standard			COM I/D
Dot Length	100.0 ms			

This dialog comprises COM/ID signal settings related to the VOR signal.

#### Settings

COM/ID State.....	138
Code.....	139
Period.....	139
Frequency.....	139
Depth.....	139
Time Schema.....	139
Dot Length.....	139
Dash Length.....	139
Symbol Space.....	140
Letter Space.....	140

#### COM/ID State

Enables/disables the COM/ID signal.

See also [Chapter C, "Morse Code Settings"](#), on page 781.

Remote command:

[ :SOURce<hw> ] :VOR:COMid [ :STATe ] on page 612

**Code**

Sets the coding of the COM/ID signal by the international short name of the airport (e.g. MUC for the Munich airport).

The COM/ID tone is sent according to the selected code, see [Chapter C, "Morse Code Settings"](#), on page 781.

If no coding is set, the COM/ID tone is sent uncoded (key down).

Remote command:

[\[:SOURCE<hw>\]:VOR:COMid:CODE](#) on page 609

**Period**

Sets the period of the COM/ID signal.

Remote command:

[\[:SOURCE<hw>\]:VOR:COMid:PERiod](#) on page 611

**Frequency**

Sets the frequency of the COM/ID signal.

Remote command:

[\[:SOURCE<hw>\]:VOR:COMid:FREQuency](#) on page 610

**Depth**

Sets the AM modulation depth of the COM/ID signal.

**Note:** The sum of [Subcarrier Depth](#), [VAR Depth](#) and [COM/ID > Depth](#) must be smaller than 100 %.

Remote command:

[\[:SOURCE<hw>\]:VOR:COMid:DEPTH](#) on page 610

**Time Schema**

Sets the time schema of the Morse code for the COM/ID signal.

- "Standard"  
The set dot length determines the length of the dash, the symbol space and letter space of the Morse code.
- "User"  
You can set each length value separately.

Remote command:

[\[:SOURCE<hw>\]:VOR:COMid:TSCHEMA](#) on page 612

**Dot Length**

Sets the length of a Morse code dot.

If "Time Schema > Standard", the dot length value determines also the length of the dash (= 3 times the dot length), symbol space (= dot length) and letter space (= 3 times the dot length).

Remote command:

[\[:SOURCE<hw>\]:VOR:COMid:DOT](#) on page 610

**Dash Length**

Requires "Time Schema > User".

Sets the length of a Morse code dash.

Remote command:

[\[:SOURCE<hw>\]:VOR:COMid:DASH](#) on page 610

### Symbol Space

Requires "Time Schema > User".

Sets the length of the Morse code symbol space.

Remote command:

[\[:SOURCE<hw>\]:VOR:COMid:SYMBOL](#) on page 611

### Letter Space

Requires "Time Schema > User".

Sets the length of a Morse code letter space.

Remote command:

[\[:SOURCE<hw>\]:VOR:COMid:LETTER](#) on page 611

## 6.4 ILS Configuration and Settings

Option: R&S SMAB-K25

Access:

- ▶ Select "Modulation > Avionic Standards > ILS".

The remote commands required to define ILS settings are described in [Chapter 14.16.2.4, "SOURCE:ILS Subsystem"](#), on page 585.

### Settings

- [General Settings](#)..... 140
- [ILS Glide Slope Settings](#)..... 143
- [ILS Localizer Settings](#)..... 149
- [ILS Marker Beacons Settings](#)..... 158

### 6.4.1 General Settings

This chapter comprises general settings, which are common for all ILS components.



Access:

- ▶ Select "ILS > General".

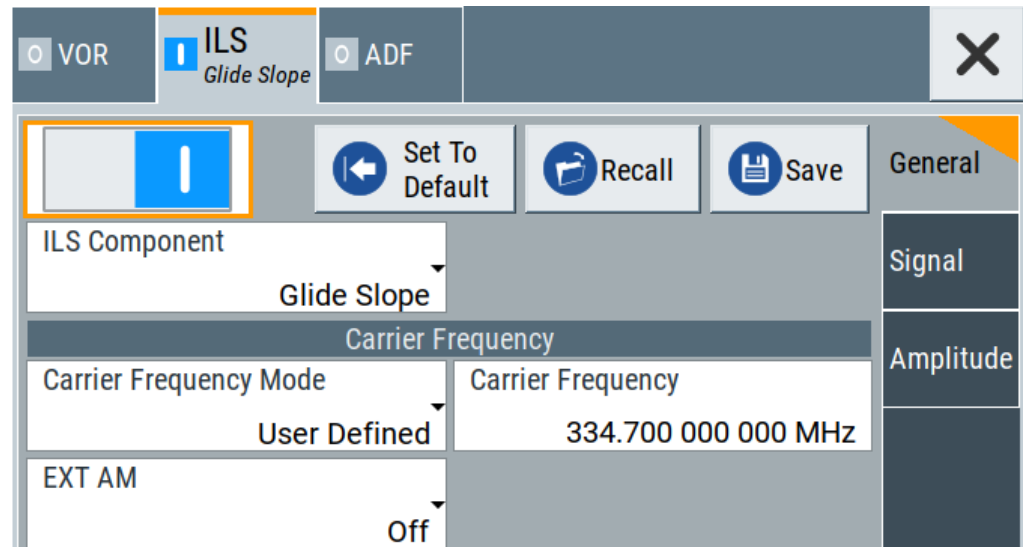

This dialog comprises general settings of the ILS standard, the default and the "Save/Recall" settings.

By default, an ILS glide slope modulation signal on an RF carrier with a frequency of 344.7 MHz or ICAO channel 18X. The dual-tone LF signal with frequencies 90 Hz and 150 Hz and a balanced modulation at SDM of 80 %.

If enabled, the avionic standard modulation is displayed in the "Modulation" tile as follows:

- "Avionic: VOR" for enabled VOR modulation
- "Avionic ILS: Glide Slope/Localizer/Marker Bcn" for enabled ILS glide slope/localizer/marker beacons modulation
- "Avionic: ADF" for enabled ADF modulation

Changing a parameter in the avionic standards causes an instant signal change in the R&S SMA100B. There is no extra measurement cycle to calculate the RMS value of the baseband signal to set the correct RF level.

If the avionics standard is activated for the first time, or after every subsequent on/off sequence, the measurement cycle will take place to determine the correct RF level. Every subsequent parameter change in the avionic standard is performed without another measurement cycle to provide a continuous signal output.

### Settings

State.....	142
Set To Default.....	142
Save/Recall.....	142
ILS Component.....	142

**State**

Activates the avionic standard.

Activation of the standard deactivates a previously active avionic standard. The "VOR/ILS > Carrier Frequency" setting is applied automatically to the RF [Frequency](#) and displayed in the status bar.

Remote command:

[<subsystem>:STATe](#) on page 581

**Set To Default**

Calls the default settings. The values of the main parameters are listed in the following table.

Standard	Parameter	Value
VOR/ILS/ADF	State	Not affected by "Set to default"
VOR	Carrier Frequency Mode	User Defined
	Carrier Frequency	108.000000 MHz
ILS	ILS Component	Glide Slope (GS)
	ILS GS > Carrier Frequency Mode	User Defined
	ILS GS > Carrier Frequency	334.700000 MHz
ADF	Carrier Frequency	190.000 kHz

Remote command:

[<subsystem>:PRESet](#) on page 579

**Save/Recall**

Accesses the "Save/Recall" dialog, that is the standard instrument function for saving and recalling the complete dialog-related settings in a file. The provided navigation possibilities in the dialog are self-explanatory.

The filename and the directory, in that the settings are stored, are user-definable; the file extension is however predefined.

Remote command:

[<subsystem>:SETTing:CATalog](#) on page 580

[<subsystem>:SETTing:DELeTe](#) on page 580

[<subsystem>:SETTing:LOAD](#) on page 580

[<subsystem>:SETTing:STORe](#) on page 581

**ILS Component**

Sets the ILS component.

"Glide slope"      Enables the glide slope.

"Localizer"        Enables the localizer.

"Marker Beacons"      Enables the marker beacons.

Remote command:

[\[:SOURce<hw>\]:ILS:TYPE](#) on page 586

## 6.4.2 ILS Glide Slope Settings

Access:

1. Select "ILS > General".
2. Select "ILS Component > Glide Slope".

### Settings

- [General Settings](#)..... 143
- [Signal Settings](#)..... 145
- [Amplitude Settings](#)..... 147

### 6.4.2.1 General Settings

Access:

1. Select "ILS Component > Glide Slope", see [Chapter 6.4.2, "ILS Glide Slope Settings"](#), on page 143.
2. Select "ILS > General".

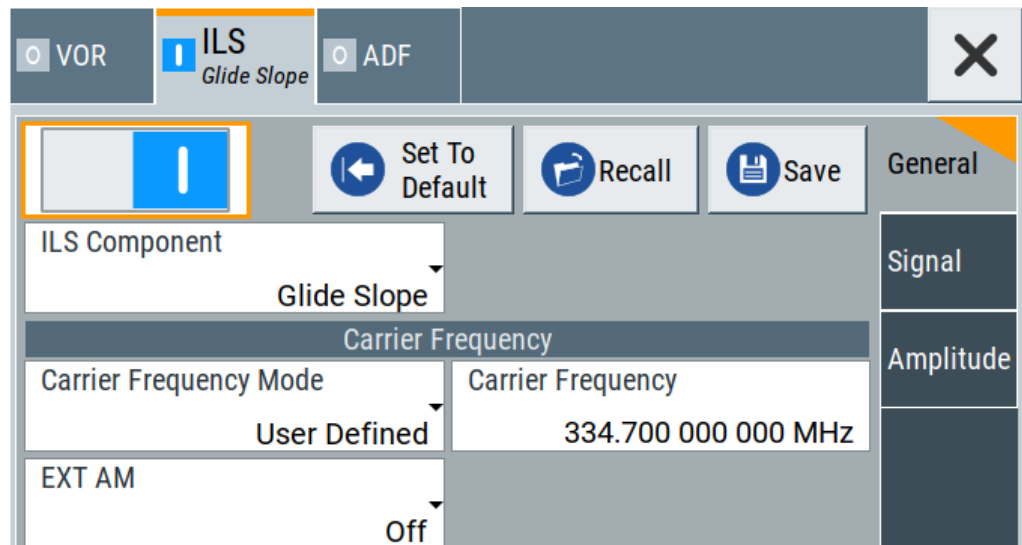

This dialog comprises carrier frequency settings related to the ILS glide slope component of the ILS signal.

### Settings

- [Carrier Frequency Mode](#)..... 144
- [Carrier Frequency](#)..... 144
- [ICAO Channel](#)..... 144
- [Sync with Glide Slope/ Sync with Localizer](#)..... 144
- [EXT AM](#)..... 144

**Carrier Frequency Mode**

Sets the mode for the carrier frequency of the signal.

Select "Carrier Frequency Mode > ICAO" to set a standard ILS frequency channel. If you want to couple carrier frequencies of ILS glide slope and localizer components, enable [Sync with Glide Slope/ Sync with Localizer](#).

"User Defined" Activates user-defined variation of the carrier frequency.

"ICAO" Activates variation in predefined steps according to standard ILS transmitting frequencies (see [Table 6-2](#)).

Remote command:

`[ :SOURce<hw> ] : ILS [ :GS | GSLope ] : FREQuency : MODE` on page 590

**Carrier Frequency**

Requires "Carrier Frequency Mode > User Defined".

Sets the carrier frequency of the signal.

Remote command:

`[ :SOURce<hw> ] : ILS [ :GS | GSLope ] : FREQuency` on page 589

**ICAO Channel**

Requires "Carrier Frequency Mode > ICAO".

Sets the ICAO channel and the corresponding transmitting frequency.

If avionic standard modulation is activated and you change the "RF Frequency", the frequency value of the closest ICAO channel is applied automatically. The "ICAO Channel" is also updated.

For an overview of the ILS ICAO channel frequencies, see [Table 6-2](#).

Remote command:

`[ :SOURce<hw> ] : ILS [ :GS | GSLope ] : ICAO : CHANnel` on page 590

**Sync with Glide Slope/ Sync with Localizer**

Activates synchronization of the ILS glide slope with the ILS localizer carrier frequency or vice versa.

If "Carrier Frequency Mode > User", the ILS glide slope carrier frequency is applied to the ILS localizer carrier frequency or vice versa.

If "Carrier Frequency Mode > ICAO", the ILS glide slope ICAO channel is applied to the ILS localizer ICAO channel or vice versa. The ILS glide slope/localizer frequency of the ICAO channel ([Table 6-2](#)) is set automatically.

Remote command:

`<subsystem> : FREQuency : SYNChronize : STATe` on page 581

**EXT AM**

Enables/disables additional modulation from an external source. The external signal is input via the Ext connector.

"Off" Selects the internal modulation source for the avionic standard modulation.

"EXT (MOD AM)"

Selects the external source. The external signal is added to the internal signal. Switching off the internal source is not possible. The external signal is input via the Ext connector. The sensitivity is 10 mV per percent modulation depth.

**Note:** There can be an overmodulation as a function of the level of the external signal without a corresponding caution message being generated. To avoid an overmodulation, the peak value of the external signal is to be delimited corresponding to the sum of the modulation depths of the remaining VOR signal components.

Remote command:

[ :SOURce<hw> ] : ILS [ :GS | GSLope ] : SOURce on page 592

**6.4.2.2 Signal Settings**

Access:

1. Select "ILS Component > Glide Slope", see [Chapter 6.4.2, "ILS Glide Slope Settings"](#), on page 143.
2. Select "ILS > Signal".

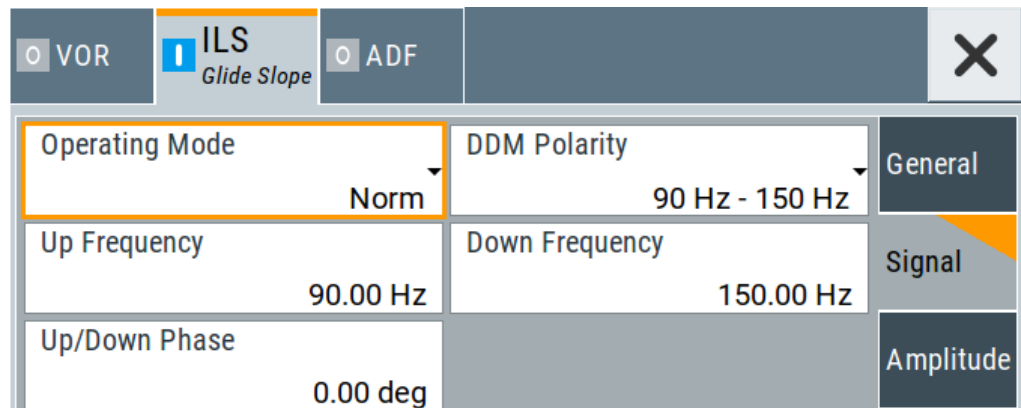

This dialog comprises modulation signal settings related to the ILS glide slope component of the ILS signal.

**Settings**

<a href="#">Operating Mode</a> .....	145
<a href="#">DDM Polarity</a> .....	146
<a href="#">Up Frequency</a> .....	146
<a href="#">Down Frequency</a> .....	146
<a href="#">Up/Down Phase</a> .....	146

**Operating Mode**

Selects the operating mode for the ILS glide slope modulation signal.

"Norm"            ILS glide slope modulation is active.

- "90 Hz" Amplitude modulation of the output signal with the upper lobe signal component (90 Hz signal content) of the ILS glide slope signal.  
The modulation depth of the 90 Hz signal results from the settings of the parameters [Sum of Depth](#) and [DDM Depth](#) according to:
- "Fly > Down"  

$$\text{AM (90 Hz)} = 0.5 \times (\text{SDM} + \text{DDM} \times 100 \%)$$
  - "Fly > Up"  

$$\text{AM (90 Hz)} = 0.5 \times (\text{SDM} - \text{DDM} \times 100 \%)$$
- "150 Hz" Amplitude modulation of the output signal with the lower lobe signal component (150 Hz signal content) of the ILS glide slope signal.  
The modulation depth of the 150 Hz signal results from the settings of parameters [Sum of Depth](#) and [DDM Depth](#) according to:
- "Fly > Down"  

$$\text{AM (150 Hz)} = 0.5 \times (\text{SDM} + \text{DDM} \times 100 \%)$$
  - "Fly > Up"  

$$\text{AM (150 Hz)} = 0.5 \times (\text{SDM} - \text{DDM} \times 100 \%)$$

Remote command:

[\[:SOURce<hw>\]:ILS\[:GS|GSLope\]:MODE](#) on page 591

#### DDM Polarity

Defines the polarity for DDM calculation (see ["DDM Depth"](#) on page 148).

Remote command:

[\[:SOURce<hw>\]:ILS\[:GS|GSLope\]:DDM:POLarity](#) on page 588

#### Up Frequency

Sets the modulation frequency of the upper antenna lobe.

Remote command:

[\[:SOURce<hw>\]:ILS\[:GS|GSLope\]:ULObE\[:FREQuency\]](#) on page 593

#### Down Frequency

Sets the modulation frequency of the lower antenna lobe.

Remote command:

[\[:SOURce<hw>\]:ILS\[:GS|GSLope\]:LLObE\[:FREQuency\]](#) on page 591

#### Up/Down Phase

Sets the phase between the modulation signals of the upper and lower antenna lobe.

The zero crossing of the lower lobe (150Hz) signal serves as a reference. The angle refers to the period of the signal of the lower antenna lobe.

Remote command:

[\[:SOURce<hw>\]:ILS\[:GS|GSLope\]:PHASe](#) on page 591

### 6.4.2.3 Amplitude Settings

Access:

1. Select "ILS Component > Glide Slope", see [Chapter 6.4.2, "ILS Glide Slope Settings"](#), on page 143.
2. Select "ILS > Amplitude".

VOR		ILS Glide Slope		ADF		✕	
Fly Mode						General	
Up							
Sum of Depth			DDM - SDM Coupling			Signal	
80.0 %			Fixed DDM				
DDM Step						Amplitude	
Decimal							
DDM Current			DDM Depth				
0.0 µA			0.000 0				
DDM Logarithmic			DDM Percent				
0.000 0 dB			0.00 %				

This dialog comprises amplitude settings related to the ILS glide slope component of the ILS signal.

#### Settings

<a href="#">Sum of Depth</a> .....	147
<a href="#">FlyMode</a> .....	148
<a href="#">DDM Step</a> .....	148
<a href="#">DDM Current</a> .....	148
<a href="#">DDM Depth</a> .....	148
<a href="#">DDM Logarithmic</a> .....	148
<a href="#">DDM Percent</a> .....	149
<a href="#">DDM - SDM Coupling</a> .....	149

#### Sum of Depth

Sets the arithmetic sum of the modulation depths of the upper lobe (90 Hz) and lower lobe (150 Hz) ILS glide slope signal contents.

The RMS modulation depth of the sum signal depends on the phase setting of both modulation tones.

Remote command:

[ :SOURce<hw> ] : ILS [ :GS | GSLope ] : SDM on page 592

**FlyMode**

Selects the simulation mode for the ILS glide slope modulation signal. A change of the setting automatically changes the sign of the DDM value.

This setting simulates the direction in which the pilot has to correct the course.

- |        |  |
|--------|--|
| "Up"   | The 150 Hz modulation signal is predominant, the DDM value is negative (the airplane is too low, it must climb).   |
| "Down" | The 90 Hz modulation signal is predominant, the DDM value is positive (the airplane is too high, it must descend). |

Remote command:

`[ :SOURCE<hw> ] : ILS [ :GS | GSLope ] : DDM : DIRection` on page 587

**DDM Step**

Selects the variation of the DDM values.

- |              |   |
|--------------|---|
| "Decimal"    | Decimal variation according to the current cursor position.             |
| "Predifined" | Variation in predefined steps according to the standardized DDM values. |

Remote command:

`[ :SOURCE<hw> ] : ILS [ :GS | GSLope ] : DDM : STEP` on page 589

**DDM Current**

Sets the current of the ILS indicating the instrument corresponding to the DDM value. The instrument current is calculated according to:

$$\text{DDM Current } \mu\text{A} = \text{DDM Depth } [\%] \times 857,125 \mu\text{A}$$

A variation of the instrument current automatically leads to a variation of the DDM value and the DDM value in dB.

Remote command:

`[ :SOURCE<hw> ] : ILS [ :GS | GSLope ] : DDM : CURRent` on page 587

**DDM Depth**

Sets the difference in depth of modulation between the upper lobe (90 Hz) and the lower lobe (150 Hz) tone of the ILS glide slope modulation signal.

The DDM value is calculated with the formula:

- "DDM Polarity > 90 Hz - 150 Hz":  
DDM = [ AM (90 Hz) - AM (150 Hz) ] / 100%
- "DDM Polarity > 150 Hz - 90 Hz":  
DDM = [ AM (150 Hz) - AM (90 Hz) ] / 100%

A variation of the DDM value automatically leads to a variation of the value of the instrument current and the DDM value in dB.

Remote command:

`[ :SOURCE<hw> ] : ILS [ :GS | GSLope ] : DDM [ : DEPT h ]` on page 589

**DDM Logarithmic**

Sets the DDM value in dB. The dB value is calculated according to:

$$\text{DDM dB} = 20 \times \text{LOG} [(SDM+DDM \times 100\%) / (SDM-DDM \times 100\%)]$$



A variation of the value automatically leads to a variation of the DDM value and the instrument current.

Remote command:

[\[:SOURce<hw>\]:ILS\[:GS|GSLope\]:DDM:LOGarithmic](#) on page 588

#### DDM Percent

Sets the difference in depth of modulation between the upper lobe (90 Hz) and the lower lobe (150 Hz) tone of the ILS glide slope modulation signal.

The DDM value in percent is calculated as follows:

- "DDM Polarity > 90 Hz - 150 Hz":  
DDM = [ AM (90 Hz) - AM (150 Hz) ]
- "DDM Polarity > 150 Hz - 90 Hz":  
DDM = [ AM (150 Hz) - AM (90 Hz) ]

A variation of the DDM value automatically leads to a variation of the value of the instrument current and the DDM value in dB.

Remote command:

[\[:SOURce<hw>\]:ILS\[:GS|GSLope\]:DDM:PCT](#) on page 588

#### DDM - SDM Coupling

Selects if the DDM value is fixed or is changed with a change of sum of modulation depths (SDM, see below).

"Fixed DDM"     The absolute DDM value stays constant, if the SDM is changed.

"Coupled to SDM"

The absolute DDM value changes, if the SDM is changed. The DDM value expressed in dB stays constant.

Remote command:

[\[:SOURce<hw>\]:ILS\[:GS|GSLope\]:DDM:COUPling](#) on page 587

### 6.4.3 ILS Localizer Settings

Access:

1. Select "ILS > General".
2. Select "ILS Component > Localizer".

#### Settings

- [General Settings](#) ..... 150
- [Signal Settings](#)..... 152
- [Amplitude Settings](#)..... 153
- [COM/ID Settings](#)..... 156

### 6.4.3.1 General Settings

Access:

1. Select "ILS Component > Localizer", see [Chapter 6.4.3, "ILS Localizer Settings"](#), on page 149.
2. Select "ILS > General".

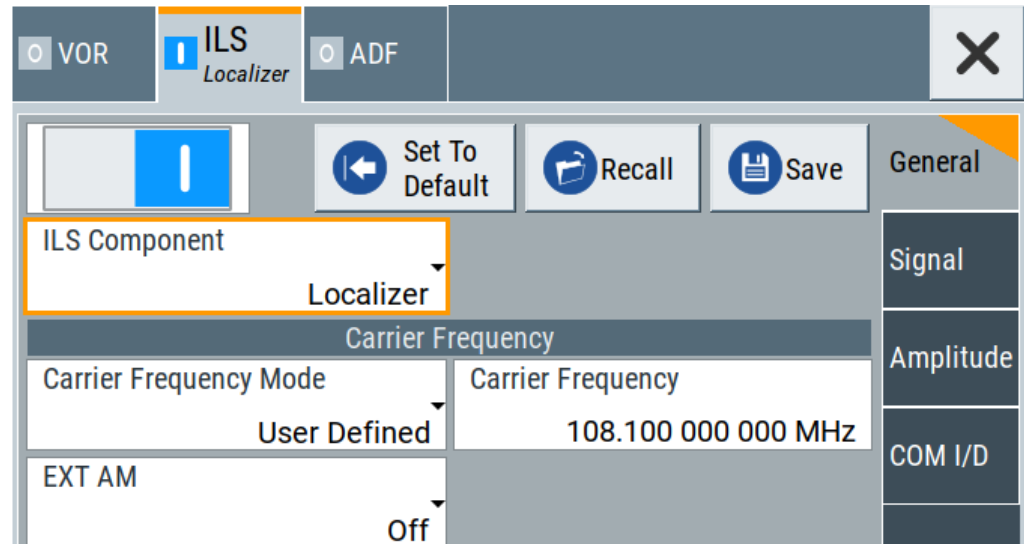

This dialog comprises carrier frequency settings related to the ILS localizer component of the ILS signal.

#### Settings

<a href="#">Carrier Frequency Mode</a> .....	150
<a href="#">Carrier Frequency</a> .....	150
<a href="#">ICAO Channel</a> .....	151
<a href="#">Sync with Glide Slope/ Sync with Localizer</a> .....	151
<a href="#">EXT AM</a> .....	151

#### Carrier Frequency Mode

Sets the mode for the carrier frequency of the signal.

"User Defined" Activates user-defined variation of the carrier frequency.

"ICAO" Activates variation in predefined steps according to standard ILS transmitting frequencies (see [Table 6-2](#)).  
Select the [ICAO Channel](#) to set a standard ILS frequency channel. If you want to couple carrier frequencies of ILS glide slope and localizer components, enable [General Settings](#) .

Remote command:

[\[:SOURce<hw>\]:ILS:LOCalizer:FREquency:MODE](#) on page 599

#### Carrier Frequency

Requires "Carrier Frequency Mode > User Defined".

Sets the carrier frequency of the signal.

Remote command:

`[ :SOURce<hw> ] : ILS : LOCalizer : FREQuency` on page 599

### ICAO Channel

Requires "Carrier Frequency Mode > ICAO".

Sets the ICAO channel and the corresponding transmitting frequency.

If avionic standard modulation is activated and you change the "RF Frequency", the frequency value of the closest ICAO channel is applied automatically. The "ICAO Channel" is also updated.

For an overview of the ILS ICAO channel frequencies, see [Table 6-2](#).

Remote command:

`[ :SOURce<hw> ] : ILS : LOCalizer : ICAO : CHANnel` on page 600

### Sync with Glide Slope/ Sync with Localizer

Activates synchronization of the ILS glide slope with the ILS localizer carrier frequency or vice versa.

If "Carrier Frequency Mode > User", the ILS glide slope carrier frequency is applied to the ILS localizer carrier frequency or vice versa.

If "Carrier Frequency Mode > ICAO", the ILS glide slope ICAO channel is applied to the ILS localizer ICAO channel or vice versa. The ILS glide slope/localizer frequency of the ICAO channel ([Table 6-2](#)) is set automatically.

Remote command:

`<subsystem> : FREQuency : SYNChronize : STATe` on page 581

### EXT AM

Enables/disables additional modulation from an external source. The external signal is input via the Ext connector.

"Off"                      Selects the internal modulation source for the avionic standard modulation.

"EXT (MOD AM)"

Selects the external source. The external signal is added to the internal signal. Switching off the internal source is not possible. The external signal is input via the Ext connector. The sensitivity is 10 mV per percent modulation depth.

**Note:** There can be an overmodulation as a function of the level of the external signal without a corresponding caution message being generated. To avoid an overmodulation, the peak value of the external signal is to be delimited corresponding to the sum of the modulation depths of the remaining VOR signal components.

Remote command:

`[ :SOURce<hw> ] : ILS : LOCalizer : SOURce` on page 602

### 6.4.3.2 Signal Settings

Access:

1. Select "ILS Component > Localizer", see [Chapter 6.4.3, "ILS Localizer Settings"](#), on page 149.
2. Select "ILS > Signal".

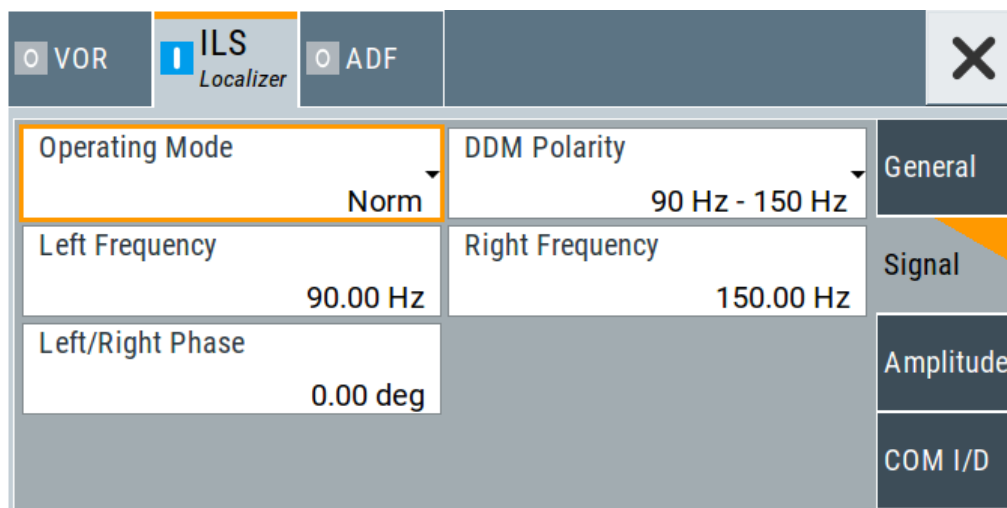

This dialog comprises audio signal and modulation settings related to the ILS localizer component of the ILS signal.

#### Settings

<a href="#">Operating Mode</a> .....	152
<a href="#">DDM polarity</a> .....	153
<a href="#">Left Frequency</a> .....	153
<a href="#">Right Frequency</a> .....	153
<a href="#">Left/Right Phase</a> .....	153

#### Operating Mode

Selects the operating mode for the ILS localizer modulation signal.

- "Norm" ILS localizer modulation is active.
- "90 Hz" Amplitude modulation of the output signal with the left lobe (90 Hz) signal component of the ILS localizer signal.  
The modulation depth of the 90 Hz signal results from the settings of parameters [Sum of Depth](#) and [DDM Depth](#) according to:
  - "Fly > Right"  
 $AM(90\text{ Hz}) = 0.5 \times (SDM + DDM \times 100\%)$
  - "Fly > Left"  
 $AM(90\text{ Hz}) = 0.5 \times (SDM - DDM \times 100\%)$

- "150 Hz" Amplitude modulation of the output signal with the right lobe (150 Hz) signal component of the ILS localizer signal.
- The modulation depth of the 150 Hz signal results from the settings of parameters [Sum of Depth](#) and [DDM Depth](#) according to:
- "Fly" = "Right"  

$$\text{AM (150 Hz)} = 0.5 \times (\text{SDM} + \text{DDM} \times 100 \%)$$
  - "Fly" = "Left"  

$$\text{AM (150 Hz)} = 0.5 \times (\text{SDM} - \text{DDM} \times 100 \%)$$

Remote command:

[\[:SOURCE<hw>\]:ILS:LOCALIZER:MODE](#) on page 601

#### DDM polarity

Defines the polarity for DDM calculation (see ["DDM Depth"](#) on page 155).

Remote command:

[\[:SOURCE<hw>\]:ILS:LOCALIZER:DDM:POLARITY](#) on page 598

#### Left Frequency

Sets the modulation frequency of the antenna lobe arranged at the left viewed from the air plane.

Remote command:

[\[:SOURCE<hw>\]:ILS:LOCALIZER:LLOBE\[:FREQUENCY\]](#) on page 600

#### Right Frequency

Sets the modulation frequency of the antenna lobe arranged at the right viewed from the air plane.

Remote command:

[\[:SOURCE<hw>\]:ILS:LOCALIZER:RLOBE\[:FREQUENCY\]](#) on page 602

#### Left/Right Phase

Sets the phase between the modulation signals of the left and right antenna lobe. The zero crossing of the right lobe (150 Hz) signal serves as a reference. The angle refers to the period of the signal of the right antenna lobe.

Remote command:

[\[:SOURCE<hw>\]:ILS:LOCALIZER:PHASE](#) on page 601

### 6.4.3.3 Amplitude Settings

Access:

1. Select "ILS Component > Localizer", see [Chapter 6.4.3, "ILS Localizer Settings"](#), on page 149.

2. Select "ILS > Amplitude".

VOR		ILS Localizer		ADF		✕	
Fly Mode						General	
Left							
Sum of Depth			DDM - SDM Coupling			Signal	
40.0 %			Fixed DDM				
DDM Step						Amplitude	
Decimal							
DDM Current			DDM Depth			COM I/D	
0.0 µA			0.000 0				
DDM Logarithmic			DDM Percent				
0.000 0 dB			0.00 %				

This dialog comprises amplitude settings related to the ILS localizer component of the ILS signal.

### Settings

FlyMode.....	154
Sum of Depth.....	154
DDM - SDM Coupling.....	155
DDM Step.....	155
DDM Current.....	155
DDM Depth.....	155
DDM Logarithmic.....	156
DDM Percent.....	156

### FlyMode

Selects the simulation mode for the ILS localizer modulation signal. A change of the setting automatically changes the sign of the DDM value.

This setting simulates the direction in which the pilot has to correct the course.

"Left"	The 150 Hz modulation signal is predominant, the DDM value is negative (the airplane is too far to the right, it must turn to the left).
"Right"	The 90 Hz modulation signal is predominant, the DDM value is positive (the airplane is too far to the left, it must turn to the right).

Remote command:

`[ :SOURce<hw> ] :ILS:LOCalizer:DDM:DIRection` on page 597

### Sum of Depth

Sets the arithmetic sum of the modulation depths of the left lobe (90 Hz) and right lobe (150 Hz) ILS localizer signal contents.

The RMS modulation depth of the sum signal depends on the phase setting of both modulation tones.

The "Sum of Depth" and "COM/ID > Depth" must be smaller than 100 %.

Remote command:

[\[:SOURce<hw>\]:ILS:LOCalizer:SDM](#) on page 602

### DDM - SDM Coupling

Selects if the DDM value is fixed or is changed with a change of sum of modulation depths (SDM, see below).

"Fixed DDM"      The absolute DDM value stays constant, if the SDM is changed.

"Coupled to SDM"      The absolute DDM value changes, if the SDM is changed. The DDM value expressed in dB stays constant.

Remote command:

[\[:SOURce<hw>\]:ILS:LOCalizer:DDM:COUPling](#) on page 596

### DDM Step

Selects the variation step of the DDM values.

"Decimal"      Decimal variation according to the current cursor position.

"Predifined"      Variation in predefined steps according to the standardized DDM values.

Remote command:

[\[:SOURce<hw>\]:ILS:LOCalizer:DDM:STEP](#) on page 598

### DDM Current

Sets the current of the ILS indicating instrument corresponding to the DDM value. The instrument current is calculated according to:

$$\text{DDM } \mu\text{A} = \text{DDM} \times 967.75 \mu\text{A}$$

A variation of the instrument current automatically leads to a variation of the DDM value and the DDM value in dB.

Remote command:

[\[:SOURce<hw>\]:ILS:LOCalizer:DDM:CURRent](#) on page 596

### DDM Depth

Sets the difference in depth of modulation (DDM) between the signal of the left lobe (90 Hz) and the right lobe (150 Hz) of the ILS localizer modulation signal.

The DDM value in percent is calculated as follows:

- "DDM Polarity > 90 Hz - 150 Hz" (default setting):  
DDM = [ AM (90 Hz) - AM (150 Hz) ] / 100 %
- "DDM Polarity > 150 Hz - 90 Hz":  
DDM = [ AM (150 Hz) - AM (90 Hz) ] / 100 %

A variation of the DDM value automatically leads to a variation of the DDM value in dB and the value of the instrument current.

Remote command:

[\[:SOURce<hw>\]:ILS:LOCalizer:DDM\[:DEPTh\]](#) on page 599

**DDM Logarithmic**

Sets the DDM value in dB. The dB value is calculated according to:

$$\text{DDM dB} = 20 \times \text{LOG} [(\text{SDM} + \text{DDM} \times 100 \%) / (\text{SDM} - \text{DDM} \times 100 \%)]$$

A variation of the value automatically leads to a variation of the DDM value and the instrument current.

Remote command:

[\[:SOURce<hw>\]:ILS:LOCalizer:DDM:LOGarithmic](#) on page 597

**DDM Percent**

Sets the difference in depth of modulation between the signal of the left lobe (90 Hz) and the right lobe (150 Hz).

The DDM value in percent is calculated by the following formulas:

- "DDM Polarity > 90 Hz - 150 Hz" (default setting):

$$\text{DDM} = [ \text{AM}(90 \text{ Hz}) - \text{AM}(150 \text{ Hz}) ]$$

- "DDM Polarity > 150 Hz - 90 Hz":

$$\text{DDM} = [ \text{AM}(150 \text{ Hz}) - \text{AM}(90 \text{ Hz}) ]$$

A variation of the DDM value automatically leads to a variation of the DDM value in dB and the value of the instrument current.

Remote command:

[\[:SOURce<hw>\]:ILS:LOCalizer:DDM:PCT](#) on page 598

**6.4.3.4 COM/ID Settings**

Access:

1. Select "ILS Component > Localizer", see [Chapter 6.4.3, "ILS Localizer Settings"](#), on page 149.
2. Select "ILS > COM/ID".

VOR		ILS Localizer		ADF		X	
COM/ID State		<input type="checkbox"/>				General	
Code		MUC		Period		9.000 s	
Frequency		1.020 00 kHz		Depth		10.0 %	
Time Schema		Standard				COM I/D	
Dot Length		100.0 ms					



This dialog comprises COM/ID settings related to the ILS localizer component of the ILS signal.

### Settings

COM/ID State.....	157
Code.....	157
Frequency.....	157
Period.....	157
Depth.....	157
Time Schema.....	158
Dot Length.....	158
Dash Length.....	158
Symbol Space.....	158
Letter Space.....	158

### COM/ID State

Enables/disables the COM/ID signal.

See also [Chapter C, "Morse Code Settings"](#), on page 781.

Remote command:

`[ :SOURCE<hw> ] : ILS : LOCALizer : COMid [ : STATE ]` on page 596

### Code

Sets the coding of the COM/ID signal by the international short name of the airport (e.g. MUC for the Munich airport).

The COM/ID tone is sent according to the selected code, see [Chapter C, "Morse Code Settings"](#), on page 781.

If no coding is set, the COM/ID tone is sent uncoded (key down).

Remote command:

`[ :SOURCE<hw> ] : ILS : LOCALizer : COMid : CODE` on page 593

### Frequency

Sets the frequency of the COM/ID signal.

Remote command:

`[ :SOURCE<hw> ] : ILS : LOCALizer : COMid : FREQuency` on page 594

### Period

Sets the period of the COM/ID signal.

Remote command:

`[ :SOURCE<hw> ] : ILS : LOCALizer : COMid : PERiod` on page 595

### Depth

Sets the AM modulation depth of the COM/ID signal.

**Note:** The sum of [Sum of Depth](#) and  $\text{COM/ID} > \text{Depth}$  must be smaller than 100 %.

Remote command:

`[ :SOURCE<hw> ] : ILS : LOCALizer : COMid : DEPTH` on page 594

**Time Schema**

Sets the time schema of the Morse code for the COM/ID signal.

- "Standard"  
The set dot length determines the length of the dash, the symbol space and letter space of the Morse code.
- "User"  
You can set each length value separately.

Remote command:

[\[:SOURCE<hw>\]:ILS:LOCALizer:COMid:TSCHEMA](#) on page 595

**Dot Length**

Sets the length of a Morse code dot.

If "Time Schema > Standard", the dot length value determines also the length of the dash (= 3 times the dot length), symbol space (= dot length) and letter space (= 3 times the dot length).

Remote command:

[\[:SOURCE<hw>\]:ILS:LOCALizer:COMid:DOT](#) on page 594

**Dash Length**

Requires "Time Schema > User".

Sets the length of a Morse code dash.

Remote command:

[\[:SOURCE<hw>\]:ILS:LOCALizer:COMid:DASH](#) on page 593

**Symbol Space**

Requires "Time Schema > User".

Sets the length of the Morse code symbol space.

Remote command:

[\[:SOURCE<hw>\]:ILS:LOCALizer:COMid:SYMBOL](#) on page 595

**Letter Space**

Requires "Time Schema > User".

Sets the length of a Morse code letter space.

Remote command:

[\[:SOURCE<hw>\]:ILS:LOCALizer:COMid:LETTER](#) on page 595

## 6.4.4 ILS Marker Beacons Settings

Access:

1. Select "ILS > General".
2. Select "ILS Component > Marker Beacons".

## Settings

- [General Settings](#)..... 159
- [Signal Settings](#)..... 160
- [COM/ID Settings](#)..... 161

### 6.4.4.1 General Settings

Access:

1. Select "ILS Component > Marker Beacons", see [Chapter 6.4.4, "ILS Marker Beacons Settings"](#), on page 158.
2. Select "ILS > General".

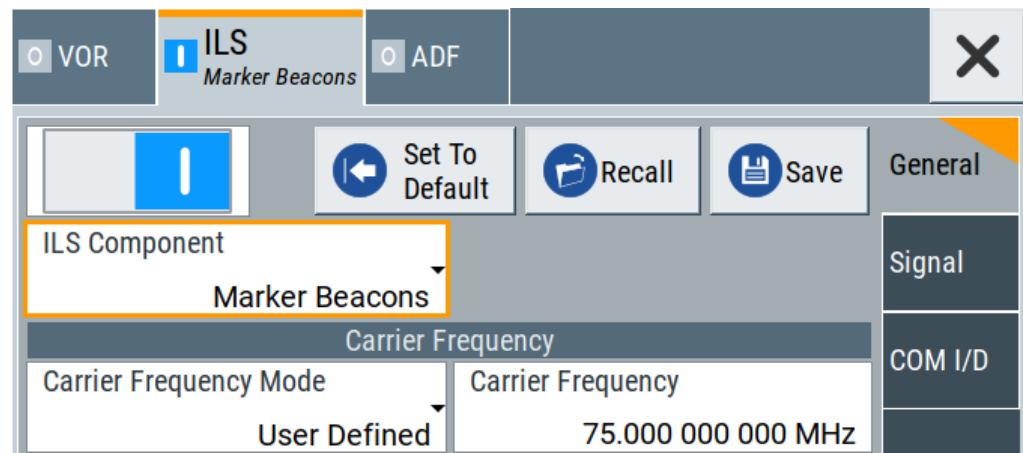

This dialog comprises carrier frequency and signal settings related to the ILS marker beacons component of the ILS signal.

## Settings

- [Carrier Frequency Mode](#)..... 159
- [Carrier Frequency](#)..... 159

### Carrier Frequency Mode

Sets the mode for the carrier frequency of the signal.

"User Defined" Activates user-defined variation of the carrier frequency.

"Predefined" Activates variation of the carrier frequency by integer 25 kHz steps.

Remote command:

[\[:SOURCE<hw>\] \[:ILS\] :MBEacon:FREQUENCY:MODE](#) on page 606

### Carrier Frequency

Requires "Carrier Frequency Mode > User Defined".

Sets the carrier frequency of the signal.

Remote command:

[\[:SOURCE<hw>\] \[:ILS\] :MBEacon:FREQUENCY](#) on page 606

### 6.4.4.2 Signal Settings

Access:

1. Select "ILS Component > Marker Beacons", see [Chapter 6.4.4, "ILS Marker Beacons Settings"](#), on page 158.
2. Select "ILS > Signal".

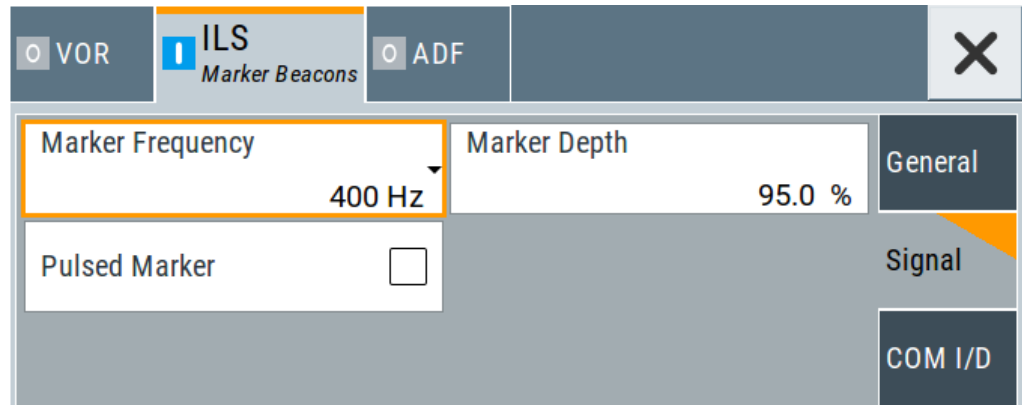

This dialog comprises signal settings related to the ILS marker beacons component of the ILS signal.

#### Settings

<a href="#">Marker Frequency</a> .....	160
<a href="#">Marker Depth</a> .....	160
<a href="#">Pulsed Marker</a> .....	160

#### Marker Frequency

Sets the modulation frequency of the marker signal.

Remote command:

[\[:SOURCE<hw>\] \[:ILS\] :MBEacon:MARKer:FREQuency](#) on page 606

#### Marker Depth

Sets the modulation depth of the marker signal.

Remote command:

[\[:SOURCE<hw>\] \[:ILS\] :MBEacon\[:MARKer\]:DEPTH](#) on page 607

#### Pulsed Marker

Activates the modulation of a pulsed marker signal (morse coding).

"On" Modulation of pulsed marker signals (morse coding). The duty cycle, i.e. the marker on- and off-times, depend on the marker signal [frequency](#) ([Table 6-3](#)).

**Table 6-3: Morse coding for ILS marker beacons marker signals**

Marker signal	On	Off	Rate	Duty cycle
Outer Marker (400 Hz)	375 ms	125 ms	2 dots/s	75 %
Middle Marker (1300 Hz)	First: 375 ms Second: 83 ms	First: 125 ms Second: 83 ms	1.5 dots/s	68.8 %
Inner Marker (3000 Hz)	83 ms	83 ms	6 dots/s	50 %

"Off" Modulation of a continuous non-coded marker signal.

Remote command:

[ :SOURce<hw>] [ :ILS ] :MBEacon [ :MARKer ] :PULSed on page 607

#### 6.4.4.3 COM/ID Settings

Access:

1. Select "ILS Component > Marker Beacons", see [Chapter 6.4.4, "ILS Marker Beacons Settings"](#), on page 158.
2. Select "ILS > COM/ID".

The screenshot shows a software interface for configuring ILS Marker Beacons. At the top, there are tabs for 'VOR', 'ILS Marker Beacons', and 'ADF'. The 'ILS Marker Beacons' tab is active. Below the tabs, there is a 'COM/ID State' checkbox, which is highlighted with an orange border. To the right of the checkbox is a 'General' tab. Below the 'COM/ID State' checkbox, there are several settings: 'Code' (MUC), 'Period' (9.000 s), 'Frequency' (1.020 00 kHz), 'Depth' (5.0 %), 'Time Schema' (Standard), and 'Dot Length' (100.0 ms). On the right side of the settings area, there are tabs for 'Signal' and 'COM I/D', with 'COM I/D' being the selected tab.

This dialog provides access to general, signal and COM/ID settings of the marker beacons component of the ILS signal.

**Settings**

COM/ID State.....	162
Code.....	162
Period.....	162
Frequency.....	162
Depth.....	162
Time Schema.....	162
Dot Length.....	163
Dash Length.....	163
Symbol Space.....	163
Letter Space.....	163

**COM/ID State**

Enables/disables the COM/ID signal.

See also [Chapter C, "Morse Code Settings"](#), on page 781.

Remote command:

`[ :SOURce<hw> ] [ :ILS ] :MBEacon:COMid[:STATe]` on page 606

**Code**

Sets the coding of the COM/ID signal by the international short name of the airport (e.g. MUC for the Munich airport).

The COM/ID tone is sent according to the selected code, see [Chapter C, "Morse Code Settings"](#), on page 781.

If no coding is set, the COM/ID tone is sent uncoded (key down).

Remote command:

`[ :SOURce<hw> ] [ :ILS ] :MBEacon:COMid:CODE` on page 603

**Period**

Sets the period of the COM/ID signal.

Remote command:

`[ :SOURce<hw> ] [ :ILS ] :MBEacon:COMid:PERiod` on page 605

**Frequency**

Sets the frequency of the COM/ID signal.

Remote command:

`[ :SOURce<hw> ] [ :ILS ] :MBEacon:COMid:FREQuency` on page 604

**Depth**

Sets the AM modulation depth of the COM/ID signal.

Remote command:

`[ :SOURce<hw> ] [ :ILS ] :MBEacon:COMid:DEPTH` on page 603

**Time Schema**

Sets the time schema of the Morse code for the COM/ID signal.

- "Standard"

The set dot length determines the length of the dash, the symbol space and letter space of the Morse code.

- "User"  
You can set each length value separately.

Remote command:

[\[:SOURce<hw>\] \[:ILS\] :MBEacon:COMid:TSCHEMA](#) on page 605

### Dot Length

Sets the length of a Morse code dot.

If "Time Schema > Standard", the dot length value determines also the length of the dash (= 3 times the dot length), symbol space (= dot length) and letter space (= 3 times the dot length).

Remote command:

[\[:SOURce<hw>\] \[:ILS\] :MBEacon:COMid:DOT](#) on page 604

### Dash Length

Requires "Time Schema > User".

Sets the length of a Morse code dash.

Remote command:

[\[:SOURce<hw>\] \[:ILS\] :MBEacon:COMid:DASH](#) on page 603

### Symbol Space

Requires "Time Schema > User".

Sets the length of the Morse code symbol space.

Remote command:

[\[:SOURce<hw>\] \[:ILS\] :MBEacon:COMid:SYMBOL](#) on page 605

### Letter Space

Requires "Time Schema > User".

Sets the length of a Morse code letter space.

Remote command:

[\[:SOURce<hw>\] \[:ILS\] :MBEacon:COMid:LETTER](#) on page 604

## 6.5 ADF Configuration and Settings

Option: R&S SMAB-K25

Access:

- ▶ Select "Modulation > Avionic Standards > ADF".

The remote commands required to define ADF settings are described in [Chapter 14.16.2.3, "SOURce:ADF Subsystem"](#), on page 582.

## Settings

- [General Settings](#)..... 164
- [COM/ID Settings](#)..... 166

### 6.5.1 General Settings

Access:

- ▶ Select "ADF > General".

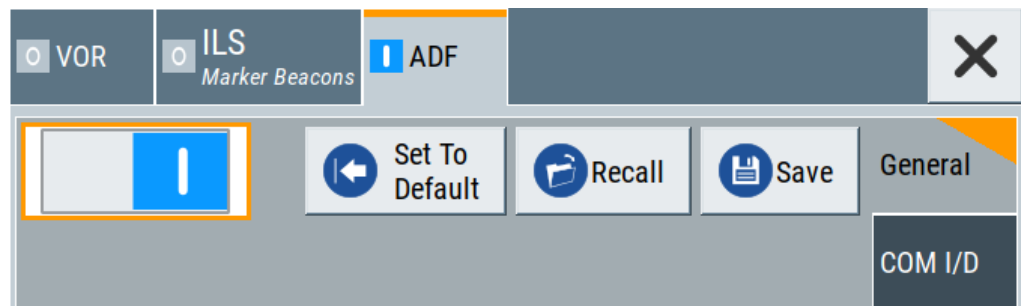

This dialog comprises general settings of the ADF standard, the default and the "Save/Recall" settings.

By default, an ADF signal modulation is set on an RF carrier with a frequency of 190 kHz. The COM/ID signal has 1.02 kHz frequency.

If enabled, the avionic standard modulation is displayed in the "Modulation" tile as follows:

- "Avionic: VOR" for enabled VOR modulation
- "Avionic ILS: Glide Slope/Localizer/Marker Bcn" for enabled ILS glide slope/localizer/marker beacons modulation
- "Avionic: ADF" for enabled ADF modulation

#### ADF state and carrier frequency range

If the R&S SMA100B carrier frequency is outside the specified ADF frequency range from 190 kHz to 1750 kHz, a settings conflict is displayed. Activating ADF is not possible.

Change the carrier frequency to a value within the specified frequency range.

Changing a parameter in the avionic standards causes an instant signal change in the R&S SMA100B. There is no extra measurement cycle to calculate the RMS value of the baseband signal to set the correct RF level.

If the avionics standard is activated for the first time, or after every subsequent on/off sequence, the measurement cycle will take place to determine the correct RF level. Every subsequent parameter change in the avionic standard is performed without another measurement cycle to provide a continuous signal output.



**Settings**

State.....	165
Set To Default.....	165
Save/Recall.....	165

**State**

Activates the avionic standard.

Activation of the standard deactivates a previously active avionic standard. The "VOR/ILS > Carrier Frequency" setting is applied automatically to the RF [Frequency](#) and displayed in the status bar.

Remote command:

[<subsystem>:STATe](#) on page 581

**Set To Default**

Calls the default settings. The values of the main parameters are listed in the following table.

Standard	Parameter	Value
VOR/ILS/ADF	State	Not affected by "Set to default"
VOR	Carrier Frequency Mode	User Defined
	Carrier Frequency	108.000000 MHz
ILS	ILS Component	Glide Slope (GS)
	ILS GS > Carrier Frequency Mode	User Defined
	ILS GS > Carrier Frequency	334.700000 MHz
ADF	Carrier Frequency	190.000 kHz

Remote command:

[<subsystem>:PRESet](#) on page 579

**Save/Recall**

Accesses the "Save/Recall" dialog, that is the standard instrument function for saving and recalling the complete dialog-related settings in a file. The provided navigation possibilities in the dialog are self-explanatory.

The filename and the directory, in that the settings are stored, are user-definable; the file extension is however predefined.

Remote command:

[<subsystem>:SETTing:CATalog](#) on page 580

[<subsystem>:SETTing:DELeTe](#) on page 580

[<subsystem>:SETTing:LOAD](#) on page 580

[<subsystem>:SETTing:STORe](#) on page 581

## 6.5.2 COM/ID Settings

Access:

- ▶ Select "ADF > COM/ID".

COM/ID State		General
Code	MUC	COM I/D
Period	9.000 s	
Frequency	1.020 00 kHz	
Depth	95.0 %	
Time Schema	Standard	
Dot Length	100.0 ms	

This dialog comprises COM/ID signal settings related to the ADF signal.

### Settings

COM/ID State.....	166
Code.....	166
Period.....	167
Frequency.....	167
Depth.....	167
Time Schema.....	167
Dot Length.....	167
Dash Length .....	167
Symbol Space .....	167
Letter Space .....	168

### COM/ID State

Enables/disables the COM/ID signal.

Remote command:

[ :SOURce<hw> ] :ADF:COMid [ :STATe ] on page 585

### Code

Sets the coding of the COM/ID signal by the international short name of the airport (e.g. MUC for the Munich airport).

The COM/ID tone is sent according to the selected code, see [Chapter C, "Morse Code Settings"](#), on page 781.

If no coding is set, the COM/ID tone is sent uncoded (key down).

Remote command:

`[ :SOURCE<hw> ] :ADF:COMid:CODE` on page 582

### Period

Sets the period of the COM/ID signal.

Remote command:

`[ :SOURCE<hw> ] :ADF:COMid:PERiod` on page 584

### Frequency

Sets the frequency of the COM/ID signal.

Remote command:

`[ :SOURCE<hw> ] :ADF:COMid:FREQuency` on page 583

### Depth

Sets the AM modulation depth of the COM/ID signal.

Remote command:

`[ :SOURCE<hw> ] :ADF:COMid:DEPTH` on page 583

### Time Schema

Sets the time schema of the Morse code for the COM/ID signal.

"Standard"      The set dot length determines the length of the dash, the symbol space and letter space of the Morse code.

"User"            You can set each length value separately.

Remote command:

`[ :SOURCE<hw> ] :ADF:COMid:TSCHEMA` on page 584

### Dot Length

Sets the length of a Morse code dot.

If "Time Schema > Standard", the dot length value determines also the length of the dash (= 3 times the dot length), symbol space (= dot length) and letter space (= 3 times the dot length).

Remote command:

`[ :SOURCE<hw> ] :ADF:COMid:DOT` on page 583

### Dash Length

Requires "Time Schema > User".

Sets the length of a Morse code dash.

Remote command:

`[ :SOURCE<hw> ] :ADF:COMid:DASH` on page 582

### Symbol Space

Requires "Time Schema > User".

Sets the length of the Morse code symbol space.

Remote command:

[\[:SOURCE<hw>\]:ADF:COMid:SYMBOL](#) on page 584

### **Letter Space**

Requires "Time Schema > User".

Sets the length of a Morse code letter space.

Remote command:

[\[:SOURCE<hw>\]:ADF:COMid:LETTER](#) on page 583

## 7 List and Sweep Mode

The operating modes "List" and "Sweep" allow you to generate an RF signal having periodically varying frequencies or amplitudes.

A signal generated with varying parameters scans a certain range of varying values of a parameter, with defined start and end points, and can be repeated cyclically.

The R&S SMA100B supports two basic methods:

- **Sweep** mode

The instrument generates an RF signal which varies its frequency or level values in discrete steps between the start and end values. The values change according to a specific shape like sawtooth or triangle. The spacing is linear or logarithmic.

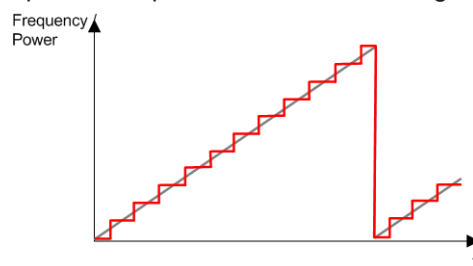

*Figure 7-1: Schematic representation of a signal generated in sweep mode*

The main application field of the "Sweep" mode is to determine the frequency response of a DUT.

- **List** mode

The instrument generates a varying output signal, based on a previously saved list with frequency, amplitude and step width values. While in sweep mode the frequency **or** the level values change, in list mode you can vary **both parameters simultaneously**. The frequency and level values do not need to have ascending or descending order, they can vary arbitrarily.

You can use a global dwell time, which means that the time interval is constant for all steps of the list, or different dwell times for each value pair.

[Figure 7-2](#) represents the frequency and power value pairs, in this case with the dwell time set the same for all steps (global dwell time).

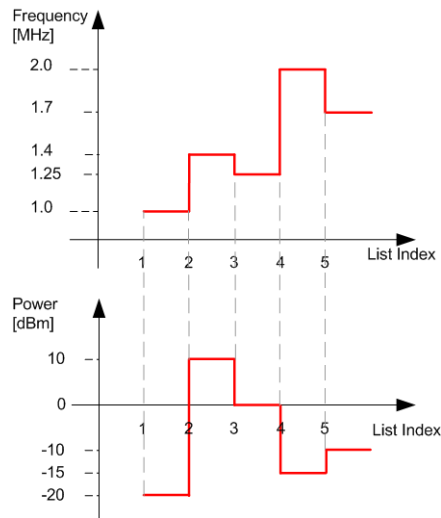

Figure 7-2: Schematic representation of a signal generated in list mode (global dwell time)

The list mode is especially useful in high-speed measurements with fast changing frequency and level settings.



Note that the shown diagrams represent the behaviour in theory. In real signal generation, the instruments usually have a blank time when the frequency or level changes.

#### Interactions and characteristics of list and sweep mode

- Activating the list mode automatically deactivates all RF and LF sweeps and vice versa.
- In list processing mode, the frequency and level display in the status bar is disabled.

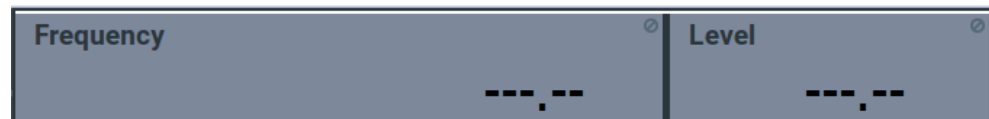

- The sweep modes only work with a *global* dwell time, that means the time intervals are constant during signal generation.
- If you want to hold a running sweep at a specific frequency or level value, enter the value in the status bar. The sweep stops immediately.
- We recommend that you switch off the display update for optimum sweep performance, especially with short dwell times  
See [Chapter 12.1.2, "Display Update Settings"](#), on page 339.

## 7.1 Signal Generation and Triggering in the Sweep and List Modes

In both operating modes "List" and "Sweep", triggering and signal generation follow the same principle. The instrument generates the signal continuously (that means triggered automatically) or in individual steps (controlled manually by an internal or external trigger signal).

The instrument expects the trigger signal at the Inst Trig connector.



If the dwell time in sweep or list mode is too short or external trigger signals come too fast, the signal generation delays. As the delay increases, the R&S SMA100B signals an overrun, or even stops sweep or list mode signal generation, if the delay gets too long.

The instrument displays corresponding error messages.

The figures in this section give an overview on the signal generation in the sweep and list modes and the appropriate triggering. The figures show the signal state after activating the mode and the generation of the signal when a trigger event occurs. For each mode, the relevant parameters and settings are briefly explained.

Each "Sweep" and "List" mode dialog provides also a "Reset" function that sets the signal to the initial value or the beginning of the list. Depending on the selected trigger mode, the signal generation proceeds accordingly.



The naming of the selection parameters in manual control (GUI) sometimes deviates from the naming in the remote-control commands. In addition, the value names of the selection parameters used in the signal generator partly differ from the SCPI syntax. The instrument accepts all value names.

The correlation between the manual control and the corresponding remote control commands, including the SCPI conform syntax are explained for each mode (see the cross-reference tables).

See also the following programming examples on the sweep and list modes in remote control:

- [Example "Setup an RF frequency or power sweep"](#) on page 676
- [Example "Setup an LF sweep"](#) on page 632
- [Example "Create an RF list and activate the list mode"](#) on page 645

## Auto mode (Sweep/List)

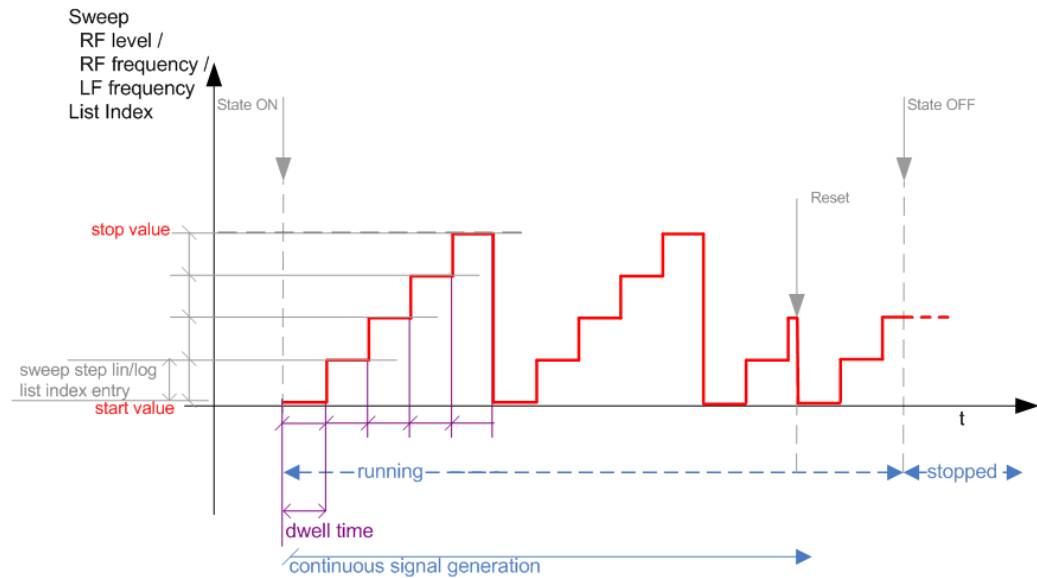

Figure 7-3: Auto mode (Sweep/List)

- The instrument generates the signal continuously.
- Trigger mode "Auto" is prerequisite (default). It causes the continuous generation of the sweep signal.
- Starts signal generation immediately with "State = On".
- Switches automatically to the next step when the **Dwell time** has elapsed.
- Stops signal generation with "State = Off".

Table 7-1: Cross-reference between manual and remote control in Auto mode (Sweep/List)

Manual control mode: "Auto"	Remote commands Rohde & Schwarz proprietary and [SCPI conform] value name
RF frequency sweep	:TRIGger<hw>:FSweep:SOURce AUTO [IMMediate] :SOURce<hw>:SWEep:FREQuency:MODE AUTO
RF level sweep	:TRIGger<hw>:PSweep:SOURce AUTO [IMMediate] :SOURce<hw>:SWEep:POWer:MODE AUTO
LF frequency sweep	:TRIGger<hw>:LFFSweep:SOURce AUTO [IMMediate] :SOURce<hw>:LFOutput<ch>:SWEep:FREQuency:MODE AUTO
List	:SOURce<hw>:LIST:MODE AUTO :SOURce<hw>:LIST:TRIGger:SOURce AUTO



### Single / Extern Single mode (Sweep/List)

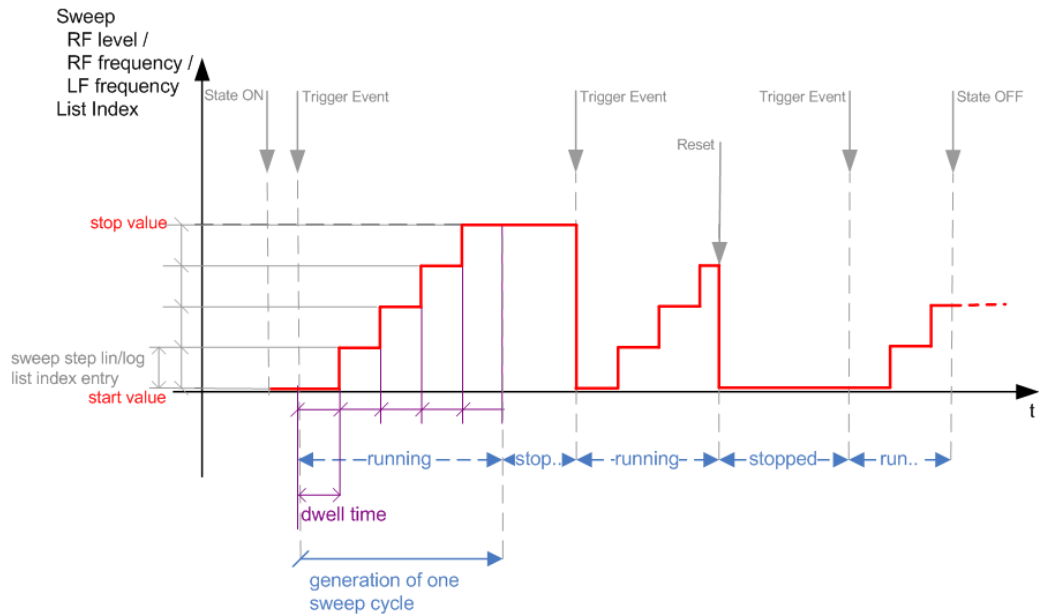

Figure 7-4: Single / Extern Single mode (sweep / list)



In single mode, you can specify, that the signal returns to the start value when a sweep cycle has been completed.

See ["The Retrace function"](#) on page 178 for details.

- The instrument generates a single sweep cycle.
- Trigger mode "Manual". A trigger event initiates one sweep from the start value to the end value.
- "State = On" sets the signal to the start value: the sweep start frequency, the sweep start power or the frequency-power value pair of the selected index in the list.
- Starts signal generation with a trigger event.
- Switches automatically to the next step when the [Dwell time](#) has elapsed.
- Stops signal generation at the set end value and waits for the subsequent trigger event.
- Trigger sources:
  - The "Execute Single Sweep" function.
  - The corresponding remote control command.
  - An externally applied trigger signal.
- "State = Off" stops the signal generation in sweep or list mode.

## Signal Generation and Triggering in the Sweep and List Modes

**Table 7-2: Cross-reference between manual and remote control in Single / Extern Single modes (Sweep/List)**

Manual control mode: "Single / Extern Single"	Remote commands Rohde & Schwarz proprietary and [SCPI conform] value name
RF frequency sweep	:TRIGger<hw>:FSWEEP:SOURce SINGLE [BUS] "Single" or :TRIGger<hw>:FSWEEP:SOURce EXTERNAL [EXTERNAL] "Extern Single" :SOURce<hw>:SWEep:FREQuency:MODE AUTO
RF level sweep	:TRIGger<hw>:PSWEEP:SOURce SINGLE [BUS] for "Single" or :TRIGger<hw>:PSWEEP:SOURce EXTERNAL [EXTERNAL] for "Extern Single" :SOURce<hw>:SWEep:POWer:MODE AUTO
LF frequency sweep	:TRIGger<hw>:LFFSWEEP:SOURce SINGLE [BUS] "Single" or :TRIGger<hw>:LFFSWEEP:SOURce EXTERNAL [EXTERNAL] "Extern Single" :SOURce<hw>:LFOuTput<ch>:SWEep:FREQuency:MODE AUTO
List	:SOURce<hw>:LIST:TRIGger:SOURce SINGLE "Single" or :SOURce<hw>:LIST:TRIGger:SOURce EXTERNAL "Extern Single" :SOURce<hw>:LIST:MODE AUTO

### Step / Extern Step mode (Sweep/List)

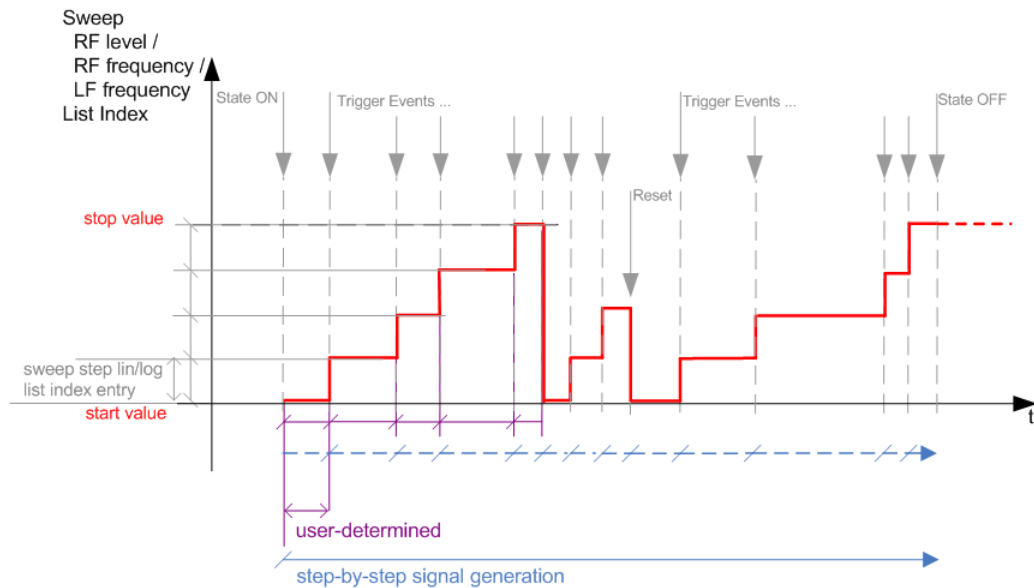

**Figure 7-5: Step / Extern Step mode (sweep / list)**

- The instrument generates the signal step-by-step.
- Starts signal generation with "State = On".
- Switches to the next step with a manual action.  
If the end value is reached, signal generation starts again from the beginning.
- Stops signal generation with "State = Off".

## Signal Generation and Triggering in the Sweep and List Modes

- Trigger sources:
  - The rotary knob at the front panel.
  - The [Arrow] keys at the front panel.
  - The corresponding remote control commands.
  - An externally applied trigger signal.

To step through the sweep frequencies or levels:

- In manual mode:
  - Set the **Current Frequency** or **Current Level** values
  - Use the [Up] and [Down] keys or the rotary knob
- In remote control mode:
  - Use the commands `[ :SOURce<hw> ] :FREQuency:MANual` or `[ :SOURce<hw> ] :POWer:MANual` with the UP or DOWN parameter



Steps that would exceed the sweep range are ignored.

**Table 7-3: Cross-reference between manual and remote control in Step / Extern Step modes (Sweep/List)**

Manual control mode: "Step / Extern Step"	Remote commands Rohde & Schwarz proprietary and [SCPI conform] value name
RF frequency sweep	:TRIGger<hw>:FSweep:SOURce SINGLE [BUS] "Step" or :TRIGger<hw>:FSweep:SOURce EXTernal [EXTernal] for "Extern Step" :SOURce<hw>:SWEep:FREQuency:MODE STEP
RF level sweep	:TRIGger<hw>:PSweep:SOURce SINGLE [BUS] "Step" or :TRIGger<hw>:PSweep:SOURce EXTernal [EXTenal] "Extern Step" :SOURce<hw>:SWEep:POWer:MODE STEP
LF frequency sweep	:TRIGger<hw>:LFFSweep:SOURce SINGLE [BUS] "Step" or :TRIGger<hw>:LFFSweep:SOURce EXTernal [EXTenal] "Extern Step" :SOURce<hw>:LFOutput<ch>:SWEep:FREQuency:MODE STEP
List	:SOURce<hw>:LIST:TRIGger:SOURce SINGLE "Step" or :SOURce<hw>:LIST:TRIGger:SOURce EXTernal "Extern Step" :SOURce<hw>:LIST:MODE STEP

### Extern Start/Stop mode (sweep)

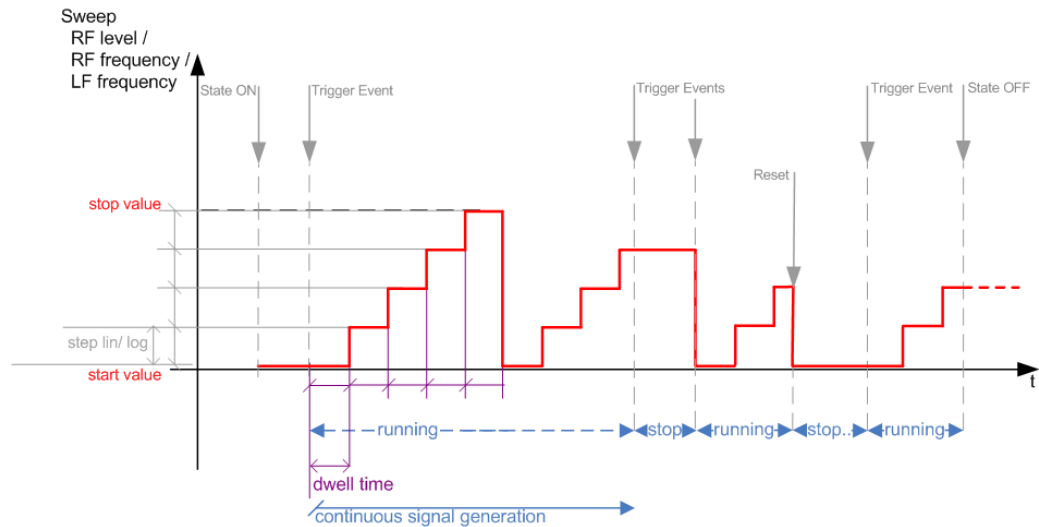

Figure 7-6: Extern Start/Stop mode (sweep)

- The instrument generates the signal continuously.
- Trigger mode "Auto" and "Sweep > State = On" are prerequisite.
- State "On" sets the signal to the start value, that is one of the following:
  - Sweep start frequency
  - Sweep start power
  - Frequency-power value pair of the selected index in the list
- Starts signal generation with a trigger event.
- Switches automatically to the next sweep step when the **Dwell time** has elapsed. If the end value is reached, signal generation continues with the next sweep cycle.
- Stops signal generation with the next external trigger event.
- Starts the signal generation again with the next trigger event, beginning at the start value.
- "State = Off" stops the signal generation in sweep or list mode.
- Trigger source: An externally applied trigger signal.

Table 7-4: Cross-reference between manual and remote control in Extern Start/Stop modes (sweep)

Manual control mode: "Extern Start/Stop"	Remote commands Rohde & Schwarz proprietary and [SCPI conform] value name
RF frequency sweep	:TRIGger<hw>:FSweep:SOURce EAUTO [-] :SOURce<hw>:SWEep:FREQuency:MODE AUTO
RF level sweep	:TRIGger<hw>:PSweep:SOURce EAUTO [-] :SOURce<hw>:SWEep:POWer:MODE AUTO
LF frequency sweep	:TRIGger<hw>:LFFSweep:SOURce EAUTO [-] :SOURce<hw>:LFOutput<ch>:SWEep:FREQuency:MODE AUTO

### Manual mode (Sweep/List)



The **manual** mode only applies to remote control. It is not visible in the graphical user interface of the instrument and is described here for completeness.

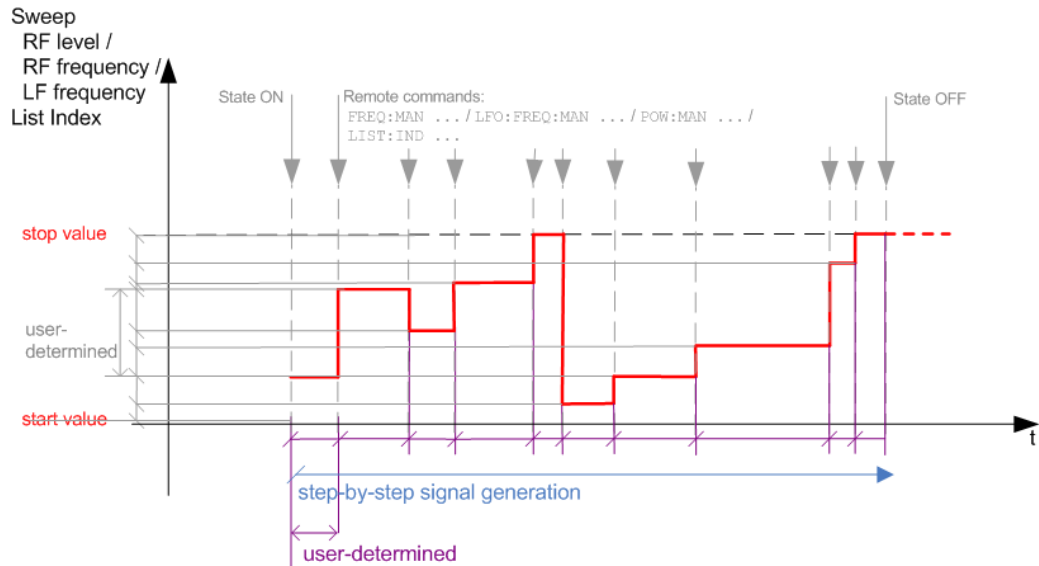

**Figure 7-7: Manual mode in remote control (sweep / list)**

- The instrument generates the signal in steps.
- Starts signal generation with "State = On".
- Switches to the next step with a user defined setting via remote control. You can arbitrarily select a value within the range of the start and stop values by setting the frequency, power or index using the corresponding remote control command. There is no ascending or descending order.
- Stops signal generation with "State = Off".

**Table 7-5: Remote control commands in manual mode (Sweep/List)**

Remote control mode:	Remote commands
Manual	Rohde & Schwarz proprietary and [SCPI conform] value name
RF frequency sweep	:SOURce<hw>:FREQUency:MANUal <Manual>
RF level sweep	:SOURce<hw>:POWER:MANUal <Manual>
LF frequency sweep	:SOURce<hw>:LFOUtpuT:FREQUency:MANUal <Manual>
List	:SOURce<hw>:LIST:INDex <Index>

### The Retrace function

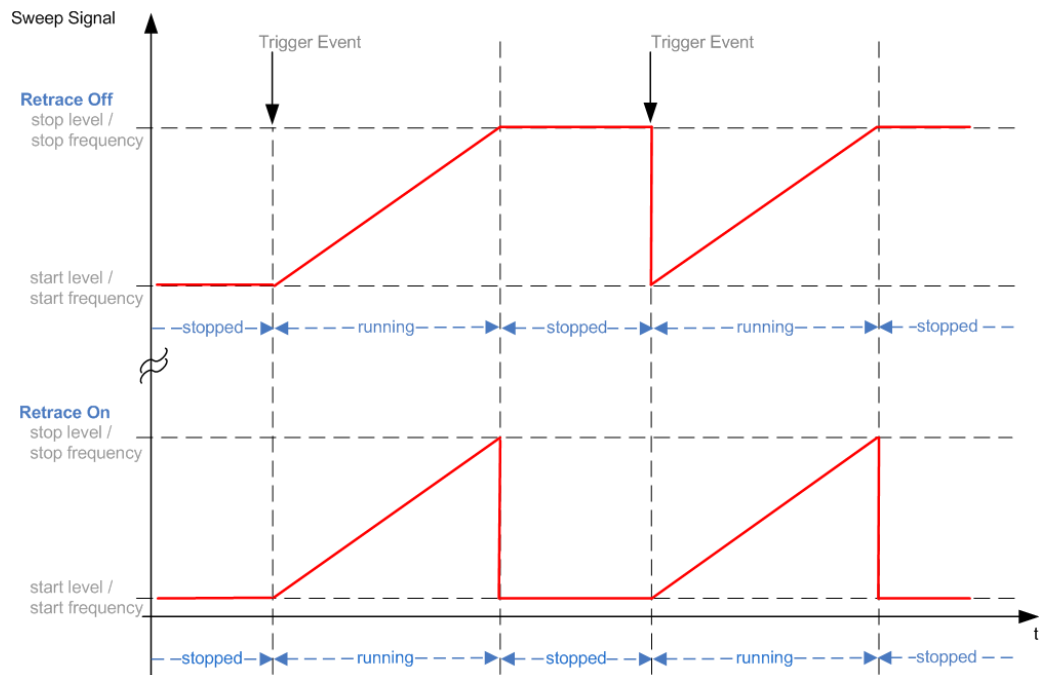

Retrace is a function especially designed for "Single" sweep modes, when the sweep signal follows a sawtooth shape. Working in this mode, the instrument performs a single sweep cycle when a trigger event occurs. The signal generation stops at the set end point (stop frequency or stop level), and waits for the next trigger event.

In this state, the upper value of the signal remains at the output until the next cycle starts. In particular, if you generate a level sweep signal, the high amplitude of the signal is output for a certain time. To protect the DUT from overload, the retrace function immediately resets the signal value to the start value at the end of a sweep cycle. It returns to the start level or start frequency until the next trigger is applied.

You can use the "Retrace" function if "Sweep > Mode = Single/External Single" and "Shape = Sawtooth", see:

- "Shape" on page 189
- "Mode" on page 187

## 7.2 About Sweep Mode

In sweep mode, the signal generator scans the sweep range gradually from one point to another, using a defined step size and following a triangle or sawtooth shape. This mode also enables you to change direction, that means, it is possible to step backwards.

See [Chapter 7.2.2, "Sweep Signal Shapes"](#), on page 181.

### Configuration and operation of sweep mode signals

- The R&S SMA100B generates a sweep signal by varying the following parameters: either the *RF frequency*, the *RF level* or both, the *RF frequency* and the *RF level* in combined RF sweep mode, or the *LF frequency*.
- In all sweep modes, you can perform a complete sweep cycle once, repeat the cycle continuously or step through it gradually.
- The instrument generates the sweep signal according to the sweep settings.
- The "Reset Sweep" function, provided in the sweep settings dialogs enables you to reset the sweep to its initial value and restart it.



### Impact of changing the sweep mode during performance

If you change the sweep mode during the execution, the signal generator stops the sweep and starts with the next trigger event at the initial value.

### Combined RF frequency / level sweep processing mode

The combined RF sweep functionality processes the signal similar to the Live list mode. The R&S SMA100B sets the frequency and level values simultaneously in the hardware. The difference to the list mode is that the values are not taken from a previously created list, but are calculated using the selected frequency and level ranges, the dwell time and the number of steps.

## 7.2.1 Correlating Parameters in Sweep Mode

A sweep signal is a periodic signal that changes its frequency or level, or both, from a starting value to an ending value in a defined time.

The R&S SMA100B provides various possibilities to configure a sweep signal. For example, you can determine the sweep range by the start and end values, or based on the start value and span. In any case, related parameters are adjusted accordingly.

The formulas below show how the sweep parameters correlate and the corresponding calculation basis, by the frequency and offset settings. Apart from "Center Frequency", "Span" and "Step\_lin", the values apply accordingly to the level settings.

**Table 7-6: Variables that are used in the following formulas**

Variable	Description
Sweep range	Defined frequency or level value range
$f_{\text{CENTer}}$	Defined center frequency
$f_{\text{SPAN}}$	Defined extend of the sweep range
$f_{\text{OFFSet}}$	Frequency offset
$f_{\text{START}}$	Start frequency of the sweep range
$f_{\text{STOP}}$	End frequency of the sweep range
$f_1$	Current sweep frequency

Variable	Description
$f_2$	Next, subsequent sweep frequency
step_lin	Step size in linear scaling
step_log	Step size in logarithmic scaling
POINTS	Number of steps within the sweep range

### Sweep range

The sweep range is defined by a start and an end value. How the remaining parameters correlate is shown below.

#### Offset = 0

Sweep Range =  $f_{\text{START}}$  to  $f_{\text{STOP}}$

$$f_{\text{CENTer}} = (f_{\text{START}} + f_{\text{STOP}})/2$$

$$f_{\text{SPAN}} = (f_{\text{STOP}} - f_{\text{START}})$$

Where:

$$f_{\text{START}} = f_{\text{CENTer}} - (f_{\text{SPAN}}/2)$$

$$f_{\text{STOP}} = f_{\text{CENTer}} + (f_{\text{SPAN}}/2)$$

#### Offset≠0

A defined offset also affects the sweep range and the center frequency. Therefore, the set frequencies are only absolute values, if the Offset = 0. Offset ≠ 0 shifts the frequencies with the offset value:

Sweep Range =  $f_{\text{START}} + f_{\text{OFFSet}}$  to  $f_{\text{STOP}} + f_{\text{OFFSet}}$

$$f_{\text{CENTer}} = f_{\text{CENTer}} + f_{\text{OFFSet}}$$

$$f_{\text{SPAN}} = f_{\text{SPAN}} + f_{\text{OFFSet}}$$

The value range of the instrument is calculated as follows:

$$RF_{\text{min}} + f_{\text{OFFSet}} \text{ to } RF_{\text{max}} + f_{\text{OFFSet}}$$



It is possible to set  $f_{\text{START}} > f_{\text{STOP}}$  and  $f_{\text{START}} < f_{\text{STOP}}$ , so that even a negative value is permitted for the "Span".

If you change the start and/or stop frequency, the span and center frequency change accordingly, and vice versa.

### Sweep steps

In the following, you see how the sweep steps are calculated depending on the defined spacing mode. The formulas show a frequency sweep, but apply to the level settings in the same way.

The step size is added to the current value, to get the subsequent sweep step.



With **linear** scaling, the next frequency is calculated according to:

$$f_2 = f_1 + \text{step\_lin}$$

In the **logarithmic** scaling, the step size is determined in per cent, as a constant fraction of the current frequency.

Successive frequencies are calculated as follows:

- For  $f_{\text{START}} < f_{\text{STOP}}$   
 $f_2 = f_1 * (1 + \text{step\_log}/100)$   
 If  $f_2 > f_{\text{STOP}}$ , then  $f_2 = f_{\text{STOP}}$
- For  $f_{\text{START}} > f_{\text{STOP}}$   
 $f_2 = f_1 / (1 + \text{step\_log}/100)$   
 If  $f_2 < f_{\text{STOP}}$ , then  $f_2 = f_{\text{STOP}}$

With "Shape = Triangle", the frequency values on the slope from  $f_{\text{STOP}}$  to  $f_{\text{START}}$  are the same as on the slope from  $f_{\text{START}}$  to  $f_{\text{STOP}}$ .

If you specify the number of steps within the sweep range, the step size is adjusted according to the following correlation:

- For **linear** sweeps and  $f_{\text{START}} < f_{\text{STOP}}$   
 $\text{POINTS}_{\text{frequency}} = ((f_{\text{START}} - f_{\text{STOP}})/\text{step\_lin}) + 1 = (f_{\text{SPAN}}/\text{step\_lin}) + 1$
- For **logarithmic** sweeps and  $f_{\text{START}} < f_{\text{STOP}}$   
 $\text{POINTS}_{\text{frequency}} = ((\log f_{\text{STOP}} - \log f_{\text{START}})/\log \text{step\_log}) + 1$

If  $\text{step\_log}$  changes, the value of POINTS is adjusted. The  $f_{\text{START}}$  and  $f_{\text{STOP}}$  values are retained.

## 7.2.2 Sweep Signal Shapes

The R&S SMA100B supports the following sweep shapes:

- Sawtooth  
 The sweep sequence resembles a sawtooth. One sweep runs from start to stop frequency, or level value respectively. Each subsequent sweep starts again at the start value.

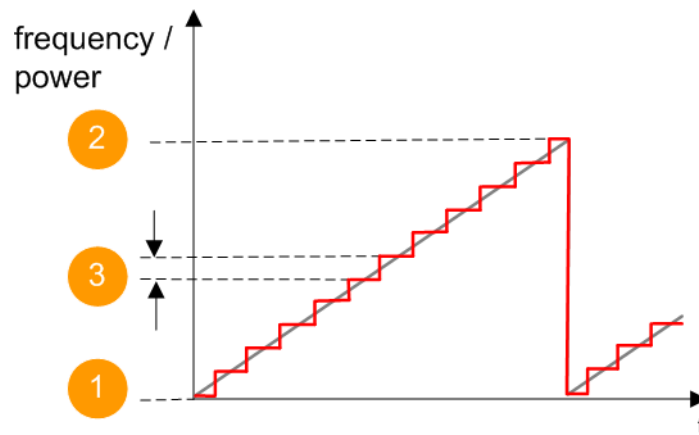

**Figure 7-8: Sweep signal sawtooth shape**

1 = Start value  
 2 = Stop value  
 3 = Step size

- Triangle  
 The sweep sequence resembles a triangle. One sweep runs from start to stop value frequency and back. Each subsequent sweep starts at the start value.

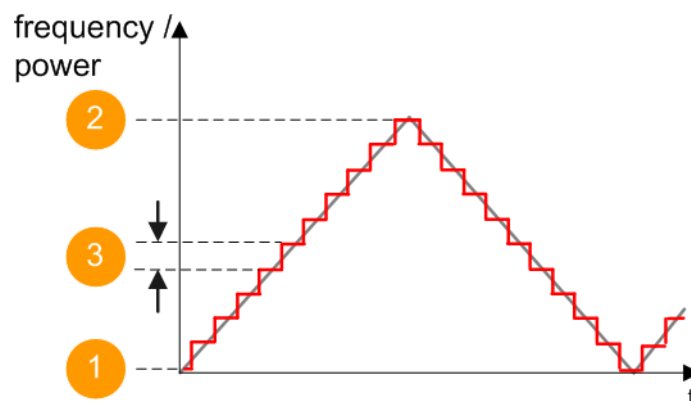

**Figure 7-9: Sweep signal triangle shape**

1 = Start value  
 2 = Stop value  
 3 = Step size

The current frequency or level of an RF frequency, level or LF frequency sweep is determined by the shape (e.g. sawtooth or triangle) and the spacing (linear or logarithmic), and the step size.

## 7.3 About List Mode

The list mode is used to generate the RF signal based on a set of predefined frequency and amplitude value pairs, with individual step times. You can define the values

arbitrarily, in any order and varying step sizes, within the entire configurable value range of the instrument.

### Configuration and operation of list mode signals

The parameters configuring the RF signal are defined in a list (table) and stored in a file.

### Creating and handling lists

List files can be created in the following ways:

- **Internally**  
Use the build-in table editor with columns for the frequency-level values pairs and the dwell time.  
Define the values manually (row by row) or automatically, based on value range and step size.  
(See [Chapter 7.7, "List Editor"](#), on page 205)  
Lists are saved as files with user-definable filename and the predefined file extension \*.lsw. To load a saved file, use the "File Manager".  
(See [Chapter 11.8, "Using the File Manager"](#), on page 318)
- Lists can be exported, too. For example, to exchange configuration between instruments or to modify the file content with an external program and reload them again.
- **Externally**  
Create a list file as a CSV file with Microsoft Excel, with a Notepad or a similar tool and save it with the predefined extension. Transfer the file to and load it into the instrument.

### Dwell time mode

You can choose whether you want to use different dwell times or a fixed value for all steps in the list mode:

- "From List"  
This mode uses the values from the data table.  
See [Edit List Mode Data](#)
- "Global"  
This mode processes the list with a fixed time interval you can set with [Global Dwell Time](#).

### List processing mode

See:

- ["Live list processing mode"](#) on page 185

## 7.4 Significant Parameters and Functions

This section provides some basic parameters, settings and functions that affect the operating modes CW, list and sweep, that means at all frequency and level transitions of the RF signal.

### Dwell time

Dwell time is the length of time that elapses from the beginning until the end of a step in list or sweep mode.

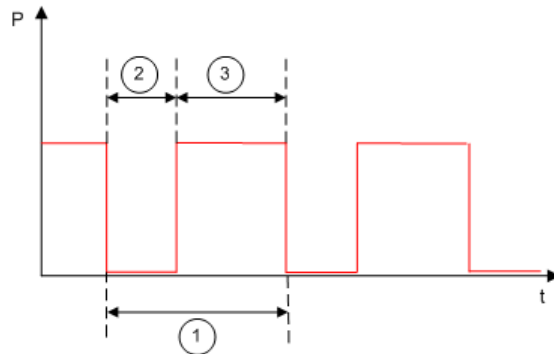

Figure 7-10: Dwell Time vs. settling time

- 1 = "Dwell Time" (as set with the parameter)
- 2 = Settling time
- 3 = Dwell time (effective)

However, the time the instrument requires for the signal to settle reduces the set dwell time:

$$t_{\text{dwell(effective)}} = t_{\text{dwell}} - t_{\text{settling}}$$



If the dwell time in sweep or list mode is too short or external trigger signals come too fast, the signal generation delays. As the delay increases, the R&S SMA100B signals an overrun, or even stops sweep or list mode signal generation, if the delay gets too long.

The instrument displays corresponding error messages.

### Hardware adjustments

The first time a list (new or modified) is processed, the instrument automatically calculates the necessary hardware settings. It can be performed during list processing, but delays the first cycle, especially with short dwell times.

With long dwell times, you can perform this calculation while the list is being processed; the entered dwell times are observed. With short dwell times, calculation of the hardware settings increases the dwell time for the initial processing cycle; the entered value is only observed from the second processing cycle onwards. In this case, a message indicates that there is a deviation between the current and set dwell times. After the first cycle, you do not need to perform additional calculations. The current dwell times do not deviate from the set dwell times.

### Blanking

The instrument applies *blanking*, which temporarily turns off the RF signal when the frequency or level changes, until the signal has settled to a stable state.

Temporary blanking applies to all operating modes.

**Live list processing mode**

The R&S SMA100B generates the signal directly from the value pairs in the database, and adjusts the hardware settings accordingly. The current instrument state and thus any change during the signal generation directly affects the RF signal. The temporary memory is not used.

You can conveniently modify parameters like modulation settings during run-time. Learning list mode data is not required. Impacts like temperature drift are also considered immediately.

This mode is optimized for **maximum signal quality**, and is useful if dwell times higher than 2 ms are sufficient.

## 7.5 Sweep Mode Settings

This section lists the settings of **all** available sweep modes.

Access:

1. Select "Sweep" > "RF Frequency Sweep"
2. Select "Sweep" > "RF Level Sweep"
3. Select "Sweep" > "RF Combined Sweep"
4. Select "Sweep" > "LF Frequency Sweep"

The remote commands required to define these settings are described in:

- [Chapter 14.16.13, "SOURce:SWEep Subsystem"](#), on page 676
- [Chapter 14.16.4, "SOURce:FREQuency Subsystem"](#), on page 624
- [Chapter 14.16.11, "SOURce:POWEr Subsystem"](#), on page 662
- [Chapter 14.16.6, "SOURce:LFOuTput Subsystem"](#), on page 632

**Settings**

• <a href="#">General Sweep Settings</a> .....	185
• <a href="#">Frequency Range Settings</a> .....	192
• <a href="#">Level Range Settings</a> .....	194
• <a href="#">Output Settings</a> .....	196
• <a href="#">Edit Marker Settings</a> .....	197

### 7.5.1 General Sweep Settings

Access:

- ▶ Select for example "Sweep" > "RF Frequency Sweep".

Table 7-7: General settings dialog: Examples of RF Frequency and RF Combined Sweep dialogs

> "RF Frequency Sweep"	> "RF Combined Sweep"

## Settings

Sweep Type .....	186
State (RF frequency sweep).....	186
State (RF level sweep).....	187
State (RF frequency / level sweep).....	187
State (LF frequency sweep).....	187
Current Frequency.....	187
Current Level.....	187
Mode.....	187
Retrace.....	188
Shape.....	189
Spacing.....	190
Sweep Time .....	190
Dwell Time .....	190
Trigger Slope.....	191
Show Connector.....	191
Reset Sweep .....	191
Execute Single Sweep .....	191

## Sweep Type

Selects the kind of the frequency sweep.

- "Step"                   Increases or decreases the frequency at each step.  
To determine the frequency intervals, see [Spacing](#).
- "Ramp"                   Provides a synthesized continuous analog frequency sweep with the set [Sweep Time](#) .

Remote command:

[\[:SOURce<hw>\]:SWEep:GENeration](#) on page 679

## State (RF frequency sweep)

Activates RF frequency sweep signal generation.

**Note:** Active RF frequency, RF level or RF combined sweep modes deactivate the LF sweep or List mode and vice versa.

Remote command:

[ :SOURce<hw> ] :FREQuency:MODE on page 625

#### State (RF level sweep)

Activates RF level sweep signal generation.

**Note:** Active RF frequency, RF level or RF combined sweep modes deactivate the LF sweep or List mode and vice versa.

Remote command:

[ :SOURce<hw> ] :POWer:MODE on page 666

#### State (RF frequency / level sweep)

Activates the RF frequency / level sweep signal generation.

**Note:** Active RF frequency, RF level or RF combined sweep modes deactivate the LF sweep or List mode and vice versa.

Remote command:

[ :SOURce<hw> ] :FREQuency:MODE on page 625

[ :SOURce<hw> ] :POWer:MODE on page 666

#### State (LF frequency sweep)

Status of the LF frequency sweep signal.

You find this parameter in two dialogs:

- "LF Frequency Sweep" turns on/off the signal generation. See [Sweep Mode Settings](#) for access.
- "Analog Modulation Sources" displays the current state (read-only). If it is turned on, this dialog provides the varying sweep frequency, see [Current Frequency](#).

**Note:** Active RF frequency, RF level or RF combined sweep modes deactivate the LF sweep or List mode and vice versa.

Remote command:

[ :SOURce<hw> ] :LFOutput:FREQuency:MODE on page 636

#### Current Frequency

Displays the current frequency sweep value for all sweep [Modes](#), except of [Mode > Step](#). In this mode, you can enter the next frequency setting manually.

Remote command:

[ :SOURce<hw> ] :FREQuency:MANual on page 627

[ :SOURce<hw> ] :LFOutput:FREQuency:MANual on page 636

#### Current Level

Displays the current level sweep value for all sweep [Modes](#), except of [Mode > Step](#). In this mode, you can enter the next level setting manually.

Remote command:

[ :SOURce<hw> ] :POWer:MANual on page 665

#### Mode

Selects the sweep mode.

See [Chapter 7.1, "Signal Generation and Triggering in the Sweep and List Modes"](#), on page 171.

"Auto" Generates a continuously repeating sweep signal directly after activating the sweep mode.  
The sweep steps are performed automatically, controlled by the dwell time.

"Single / Extern Single" Generates a single sweep cycle after a trigger event.  
The sweep steps within the cycle are performed automatically, controlled by the dwell time. If one cycle is completed, the instrument waits for the next trigger event.

"Step / Extern Step" Generates the sweep signal step-by-step, manually triggered.

"Extern Start/Stop" Generates a continuously repeating sweep signal that is started, stopped, and restarted by subsequent external trigger events.  
The sweep steps are performed automatically, controlled by the dwell time.

Remote command:

RF frequency sweep:

[\[:SOURce<hw>\]:SWEep\[:FREQuency\]:MODE](#) on page 681  
[:TRIGger<hw>:FSWEEP:SOURce](#) on page 720

RF level sweep:

[\[:SOURce<hw>\]:SWEep:POWer:MODE](#) on page 680  
[:TRIGger<hw>:PSWEEP:SOURce](#) on page 720

RF combined sweep:

[\[:SOURce<hw>\]:SWEep:COMBined:MODE](#) on page 687  
[:TRIGger<hw>:FPSWEEP:SOURce](#) on page 721

LF frequency sweep:

[\[:SOURce<hw>\]:LFOutput:SWEep\[:FREQuency\]:MODE](#) on page 642  
[:TRIGger<hw>:LFFSWEEP:SOURce](#) on page 720

### Retrace

For "Shape = Sawtooth" and "Mode = Single/External Single", enables changing the signal to the start value while it is waiting for the next trigger event. It returns to the start level or start frequency until the next trigger is applied.

Remote command:

RF frequency sweep:

[\[:SOURce<hw>\]:SWEep\[:FREQuency\]:RETRace](#) on page 683

RF level sweep:

[\[:SOURce<hw>\]:SWEep:POWer:RETRace](#) on page 683

RF combined sweep:

[\[:SOURce<hw>\]:SWEep:COMBined:RETRace](#) on page 687

LF frequency sweep:

[\[:SOURce<hw>\]:LFOutput:SWEep\[:FREQuency\]:RETRace](#) on page 643



**Shape**

Selects the waveform shape of the sweep signal.

"Sawtooth" The sweep runs from start to stop frequency. The subsequent sweep starts at the start value, i.e. the shape of the sweep sequence resembles a sawtooth.

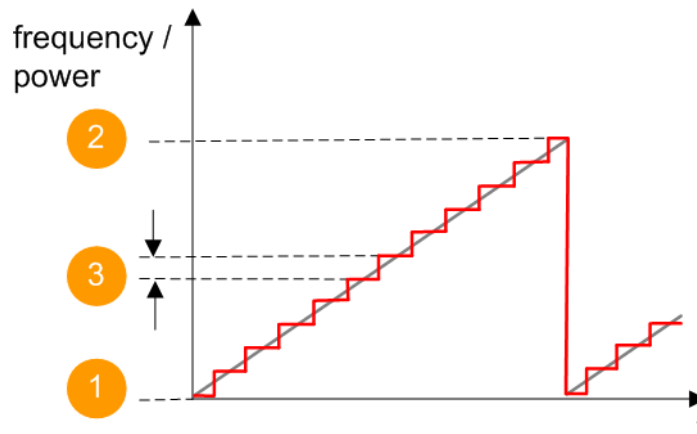

**Figure 7-11: Sweep signal sawtooth shape**

1 = Start value  
2 = Stop value  
3 = Step width

"Triangle"

The sweep runs from start to stop value and back, i.e. the shape of the sweep resembles a triangle. Each subsequent sweep starts at the start frequency.

The triangle shape is only available for [Sweep Type > Step](#).

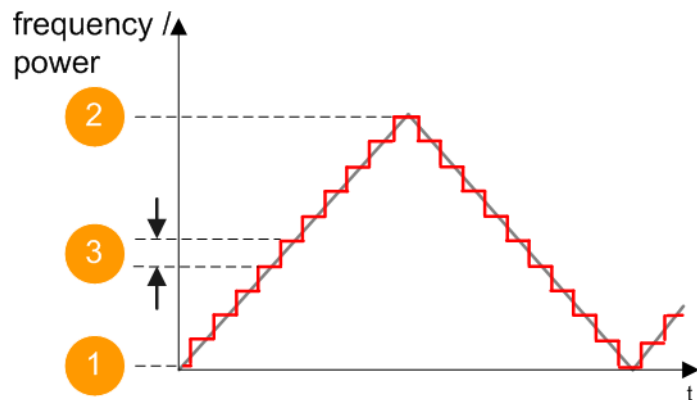

**Figure 7-12: Sweep signal triangle shape**

1 = Start value  
2 = Stop value  
3 = Step width

Remote command:

RF frequency sweep:

[ :SOURce<hw> ] :SWEep [ :FREQuency ] :SHAPE on page 683

RF level sweep:

[ :SOURce<hw> ] :SWEep:POWer:SHAPE on page 683

RF combined sweep:

[ :SOURce<hw> ] :SWEep:COMBined:SHAPE on page 688

LF frequency sweep:

[ :SOURce<hw> ] :LFOutput:SWEep [ :FREQuency ] :SHAPE on page 644

### Spacing

In "RF and LF Frequency Sweep" mode, "Spacing " selects the mode for calculating the frequency interval, which increases or decreases the current frequency at each step.

In "RF Frequency Sweep" mode and [Sweep Type > Ramp](#), the parameter automatically distributes the step intervals linearly.

To determine the step size, select the parameter [Step Linear/Step Logarithmic](#) .

In "RF Combined Sweep" mode, the parameter indicates that the step intervals are linearly (straight proportional) distributed, i.e. the intervals have the same size. The frequency / level range and the [Dwell Time](#) time determine the calculated step size.

- |               |   |
|---------------|---|
| "Linear"      | The spacing depends on the selected sweep type. <ul style="list-style-type: none"> <li>• <a href="#">Sweep Type &gt; Step</a><br/>Takes the frequency value entered as absolute value in Hz.</li> <li>• Option: R&amp;S SMAB-B28<br/><a href="#">Sweep Type &gt; Ramp</a><br/>Generates a synthesized continuous analog frequency sweep for the duration set with the parameter <a href="#">Sweep Time</a> .</li> </ul> |
| "Logarithmic" | ( <a href="#">Sweep Type &gt; Step</a> only)<br>Takes the value entered as a logarithmic value, i.e. as a constant fraction of the current frequency in %.  |

Remote command:

RF frequency sweep:

[ :SOURce<hw> ] :SWEep [ :FREQuency ] :SPACing on page 682

RF combined sweep: n.a.

LF frequency sweep:

[ :SOURce<hw> ] :LFOutput:SWEep [ :FREQuency ] :SPACing on page 644

### Sweep Time

Option: R&S SMAB-B28

For "RF Frequency Sweep" with [Sweep Type > Ramp](#), the parameter sets the duration of a ramp sweep step.

Remote command:

[ :SOURce<hw> ] :SWEep [ :FREQuency ] :TIME on page 688

### Dwell Time

Defines the duration of the individual sweep steps.

**Note:** In case of considerable overrun conditions, the R&S SMA100B turns off the sweep mode.

See also [Chapter 7.4, "Significant Parameters and Functions"](#), on page 183.

Remote command:

RF frequency sweep:

[\[:SOURce<hw>\]:SWEep\[:FREQuency\]:DWELl](#) on page 681

RF level sweep:

[\[:SOURce<hw>\]:SWEep:POWer:DWELl](#) on page 679

RF combined sweep:

[\[:SOURce<hw>\]:SWEep:COMBined:DWELl](#) on page 686

LF frequency sweep:

[\[:SOURce<hw>\]:LFOutput:SWEep\[:FREQuency\]:DWELl](#) on page 642

### Trigger Slope

For "Mode = Extern Step/Single", selects the polarity of the active slope of an applied instrument trigger.

Trigger signal is expected at the Inst Trig connector.

"Positive"            The rising edge of the trigger signal triggers the instrument.

"Negative"           The falling edge of the trigger signal triggers the instrument.

Remote command:

[\[:SOURce\]:INPut:TRIGger:SLOPe](#) on page 632



### Show Connector

Accesses a dialog that displays the physical location of the selected connector on the front/rear panel of the instrument.

### Reset Sweep

Resets a sweep.

With the next trigger event, the sweep starts at the initial value.

Remote command:

[\[:SOURce<hw>\]:SWEep:RESet\[:ALL\]](#) on page 688

### Execute Single Sweep

In "Mode = Single", starts a sweep manually.

Remote command:

RF frequency sweep:

[\[:SOURce<hw>\]:SWEep\[:FREQuency\]:EXECute](#) on page 683

[:TRIGger<hw>:FSWep\[:IMMediate\]](#) on page 722

RF level sweep:

[\[:SOURce<hw>\]:SWEep:POWer:EXECute](#) on page 683

[:TRIGger<hw>:PSWep\[:IMMediate\]](#) on page 722

RF combined sweep:

[\[:SOURce<hw>\]:SWEep:COMBined:EXECute](#) on page 686

LF frequency sweep:

[\[:SOURce<hw>\]:LFOutput:SWEep\[:FREQuency\]:EXECute](#) on page 642

[:TRIGger<hw>:LFFSweep:IMMediate](#) on page 722

General:

[:TRIGger<hw>\[:SWEep\[:IMMediate\]](#) on page 722

## 7.5.2 Frequency Range Settings

Access:

1. Select for example "Sweep" > "RF Frequency Sweep"
2. Select for example "Frequency Range".

**Table 7-8: Range settings dialog: Examples of RF Frequency and RF Combined Sweep dialogs**

> "Frequency Range"	> "Frequency / Level Range"																																																																														
<table border="1"> <tr> <td colspan="2">General <i>Single</i></td> <td>Frequency Range</td> <td>Output</td> <td>Edit Marker</td> <td>✕</td> </tr> <tr> <td>Start Frequency</td> <td colspan="2">Stop Frequency</td> <td colspan="3"></td> </tr> <tr> <td>100.000 000 000 MHz</td> <td colspan="2">500.000 000 000 MHz</td> <td colspan="3"></td> </tr> <tr> <td>Center Frequency</td> <td colspan="2">Span</td> <td colspan="3"></td> </tr> <tr> <td>300.000 000 000 MHz</td> <td colspan="2">400.000 000 000 MHz</td> <td colspan="3"></td> </tr> <tr> <td>Spacing</td> <td colspan="2">Step Linear</td> <td colspan="3"></td> </tr> <tr> <td>Linear</td> <td colspan="2">1.000 000 000 MHz</td> <td colspan="3"></td> </tr> </table>	General <i>Single</i>		Frequency Range	Output	Edit Marker	✕	Start Frequency	Stop Frequency					100.000 000 000 MHz	500.000 000 000 MHz					Center Frequency	Span					300.000 000 000 MHz	400.000 000 000 MHz					Spacing	Step Linear					Linear	1.000 000 000 MHz					<table border="1"> <tr> <td colspan="2">General <i>Auto</i></td> <td>Frequency Level Range</td> <td>Output</td> <td>Edit Marker</td> <td>✕</td> </tr> <tr> <td>Start Frequency</td> <td colspan="2">Stop Frequency</td> <td colspan="3"></td> </tr> <tr> <td>100.000 000 000 MHz</td> <td colspan="2">500.000 000 000 MHz</td> <td colspan="3"></td> </tr> <tr> <td>Start Level</td> <td colspan="2">Stop Level</td> <td colspan="3"></td> </tr> <tr> <td>-30.00 dBm</td> <td colspan="2">-10.00 dBm</td> <td colspan="3"></td> </tr> <tr> <td>Step Count</td> <td colspan="2">501</td> <td colspan="3"></td> </tr> </table>	General <i>Auto</i>		Frequency Level Range	Output	Edit Marker	✕	Start Frequency	Stop Frequency					100.000 000 000 MHz	500.000 000 000 MHz					Start Level	Stop Level					-30.00 dBm	-10.00 dBm					Step Count	501				
General <i>Single</i>		Frequency Range	Output	Edit Marker	✕																																																																										
Start Frequency	Stop Frequency																																																																														
100.000 000 000 MHz	500.000 000 000 MHz																																																																														
Center Frequency	Span																																																																														
300.000 000 000 MHz	400.000 000 000 MHz																																																																														
Spacing	Step Linear																																																																														
Linear	1.000 000 000 MHz																																																																														
General <i>Auto</i>		Frequency Level Range	Output	Edit Marker	✕																																																																										
Start Frequency	Stop Frequency																																																																														
100.000 000 000 MHz	500.000 000 000 MHz																																																																														
Start Level	Stop Level																																																																														
-30.00 dBm	-10.00 dBm																																																																														
Step Count	501																																																																														

### Settings

Start Frequency/Stop Frequency .....	192
Center Frequency .....	192
Span.....	193
Spacing.....	193
Step Linear/Step Logarithmic .....	193

### Start Frequency/Stop Frequency

Defines the frequency sweep range by setting the start and end values.

See [Chapter 7.2.1, "Correlating Parameters in Sweep Mode"](#), on page 179.

Remote command:

RF frequency sweep:

[ :SOURce<hw> ] :FREQuency:START on page 629

[ :SOURce<hw> ] :FREQuency:STOP on page 630

RF combined sweep:

[ :SOURce<hw> ] :COMBined:FREQuency:START on page 685

[ :SOURce<hw> ] :COMBined:FREQuency:STOP on page 685

LF frequency sweep:

[ :SOURce<hw> ] :LFOutput:FREQuency:START on page 637

[ :SOURce<hw> ] :LFOutput:FREQuency:STOP on page 637

### Center Frequency

In "RF Frequency Sweep" mode, sets the RF center frequency.

See [Chapter 7.2.1, "Correlating Parameters in Sweep Mode"](#), on page 179.

Remote command:

[ :SOURce<hw> ] :FREQuency:CENTer on page 629

**Span**

In "RF Frequency Sweep" mode, sets the span of the frequency sweep range.

See [Chapter 7.2.1, "Correlating Parameters in Sweep Mode"](#), on page 179.

Remote command:

`[ :SOURce<hw> ] :FREQuency :SPAN` on page 629

**Spacing**

In "RF and LF Frequency Sweep" mode, "Spacing " selects the mode for calculating the frequency interval, which increases or decreases the current frequency at each step.

In "RF Frequency Sweep" mode and [Sweep Type > Ramp](#), the parameter automatically distributes the step intervals linearly.

To determine the step size, select the parameter [Step Linear/Step Logarithmic](#) .

In "RF Combined Sweep" mode, the parameter indicates that the step intervals are linearly (straight proportional) distributed, i.e. the intervals have the same size. The frequency / level range and the [Dwell Time](#) time determine the calculated step size.

- |               |  |
|---------------|--|
| "Linear"      | <p>The spacing depends on the selected sweep type.</p> <ul style="list-style-type: none"> <li>• <a href="#">Sweep Type &gt; Step</a><br/>Takes the frequency value entered as absolute value in Hz.</li> <li>• Option: R&amp;S SMAB-B28<br/><a href="#">Sweep Type &gt; Ramp</a><br/>Generates a synthesized continuous analog frequency sweep for the duration set with the parameter <a href="#">Sweep Time</a> .</li> </ul> |
| "Logarithmic" | <p>( <a href="#">Sweep Type &gt; Step</a> only)<br/>Takes the value entered as a logarithmic value, i.e. as a constant fraction of the current frequency in %.</p>   |

Remote command:

RF frequency sweep:

`[ :SOURce<hw> ] :SWEep [ :FREQuency ] :SPACing` on page 682

RF combined sweep: n.a.

LF frequency sweep:

`[ :SOURce<hw> ] :LFOutput :SWEep [ :FREQuency ] :SPACing` on page 644

**Step Linear/Step Logarithmic**

In "RF/LF Frequency Sweep" mode, sets the step width for the individual frequency sweep steps. The value is added at each sweep step to the current frequency.

Depending on the current [Spacing](#), you can enter either an absolute or logarithmic step width.

This parameter is only available for [Sweep Type > Step](#).

See [Chapter 7.2.1, "Correlating Parameters in Sweep Mode"](#), on page 179.

"Step Linear"     The step width is a constant value in Hz.

"Step Logarithmic"

The step width is determined logarithmically in %, i.e. as a constant fraction of the current frequency.

Remote command:

- [ :SOURce<hw> ] :SWEep [ :FREQuency ] :STEP [ :LINear ] on page 684
- [ :SOURce<hw> ] :SWEep [ :FREQuency ] :STEP:LOGarithmic on page 684
- [ :SOURce<hw> ] :LFOutput:SWEep [ :FREQuency ] :STEP [ :LINear ] on page 645
- [ :SOURce<hw> ] :LFOutput:SWEep [ :FREQuency ] :STEP:LOGarithmic on page 644

### 7.5.3 Level Range Settings

Access:

1. Select "Sweep" > "RF Level Sweep"
2. Select for example "Level Range".

Table 7-9: Range settings dialog: Examples of RF Level and RF Combined Sweep dialogs

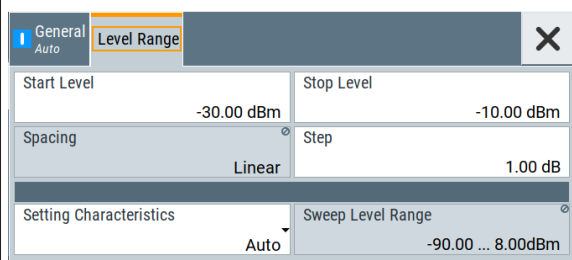
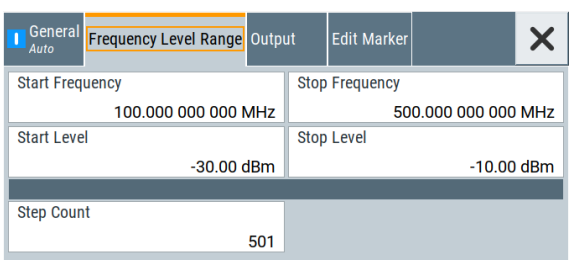
> "Level Range"	> "Frequency / Level Range"
	

#### Settings

Start Level / Stop Level .....	194
Step Count.....	195
Spacing.....	195
Step .....	195
Setting Characteristics .....	195
Sweep Level Range .....	196

#### Start Level / Stop Level

Defines the RF level sweep range by setting the start and end values.

See Chapter 7.2.1, "Correlating Parameters in Sweep Mode", on page 179.

Remote command:

RF level sweep:

[ :SOURce<hw> ] :POWER:START on page 667

[ :SOURce<hw> ] :POWER:STOP on page 667

RF combined sweep:

[ :SOURce<hw> ] :COMBined:POWER:START on page 685

[ :SOURce<hw> ] :COMBined:POWER:STOP on page 686

**Step Count**

In "RF Combined Mode", defines the number of sweeps to be executed in [Mode > Single](#).

To start the sweep cycles, select [Execute Single](#).

Remote command:

`[ :SOURce<hw> ] :SWEep:COMBined:COUNT` on page 686

**Spacing**

Indicates that the instrument distributes the level steps linearly (straight proportional), i.e. the level steps have the same size.

To determine the step size, use the parameter [Step](#).

Remote command:

n.a.

**Step**

Sets the step width for the RF level sweep in dB.

The "RF level sweep" mode increases or decreases the level value linearly by the set value.

Remote command:

`[ :SOURce<hw> ] :SWEep:POWer:STEP [ :LOGarithmic ]` on page 681

**Setting Characteristics**

Selects additional quality characteristics to optimize the behavior of the RF signal level for the specific application.

- |                     |   |
|---------------------|---|
| "Auto"              | <p>Sets the RF output level automatically according to the selected mode.</p> <p>In this mode, the instrument provides the highest dynamic range and fastest setting times, as specified in the data sheet.</p> <p>The RF signal is shortly blanked when the step attenuator is switching.</p>  |
| "Uninterrupted"     | <p>Suppresses blanking at level transitions. Frequency transitions can lead to an RF level blanking due to hardware specific switching points.</p> <p>This mode reduces the dynamic range of the instrument. The step attenuator is fixed.</p>  |
| "Strictly Monotone" | <p>Executes signal level changes monotonically increasing or decreasing.</p> <p>The setting makes sure that increasing the level value exclusively results in an increased output level, and vice versa.</p> <p>All electronic switches, which might affect the monotonicity are fixed.</p> <p>The operation mode is useful for applications using level searching algorithms which rely on a strictly monotonous behavior.</p> |
| "Constant-VSWR"     | <p>Suppresses output impedance variations at the RF output connector, due to changed level settings.</p>  |

"High Dyn. Uninterrupted"

R&S SMAB-K724

Provides a linear output power that is uninterrupted over a wide dynamic range.

**Note:** The R&S SMA100B supports this characteristic at frequencies above 52 MHz. If you select the setting at lower frequencies ( $\leq 52$  MHz), the instrument reports a settings conflict.

"User"

Indicates that a setting has been modified in the expert mode. The expert mode is a protected function, that requires protection level 2 password.

Remote command:

`[ :SOURce<hw> ] :POWer:LBEHaviour` on page 665

### Sweep Level Range

Displays the RF level sweep range.

See [Chapter 7.2.1, "Correlating Parameters in Sweep Mode"](#), on page 179.

Remote command:

`[ :SOURce<hw> ] :POWer:RANGe:MIN?` on page 670

`[ :SOURce<hw> ] :POWer:RANGe:MAX?` on page 670

## 7.5.4 Output Settings

Option: R&S SMAB-B28

Access:

1. Select "Sweep" > "RF Frequency Sweep".
2. Select "Output".

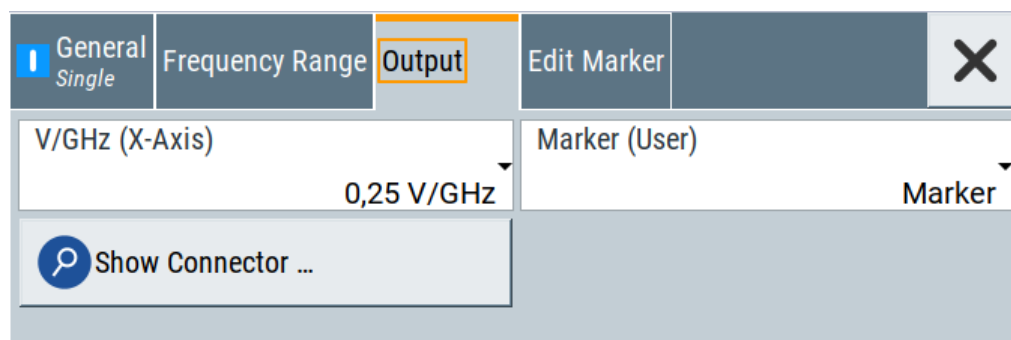

### Settings

<a href="#">V/GHz / X-Axis</a> .....	196
<a href="#">Marker / User</a> .....	197

### V/GHz / X-Axis

Option: R&S SMAB-B28

Selects the mode the voltage is supplied depending on the frequency.



The R&S SMA100B supplies the signal at the V/GHz X-Axis connector.

"0,25 V/GHz" / Supplies the voltage proportional to the set frequency, derived from  
"0,5 V/GHz" / the selected setting.  
"1 V/GHz"

"X-Axis" Supplies a voltage range from 0 V to 10 V proportional to the fre-  
quency sweep range, set with [Start Frequency/Stop Frequency](#) .

Remote command:

[:OUTPut:FPRoportional:SCALe](#) on page 476

#### **Marker / User**

Option: R&S SMAB-B28

Selects the signal to be supplied at the Marker User1 connector.

"Marker" Assigns a marker signal to the output.  
To configure and assign the marker signals, see [Chapter 7.5.5, "Edit  
Marker Settings"](#), on page 197.

"User" Intended for future use.

Remote command:

[:OUTPut:USER:MARKer](#) on page 477

### **7.5.5 Edit Marker Settings**

Option: R&S SMAB-B28

Access:

1. Select "Sweep" > "RF Frequency Sweep"
2. Select "Edit Marker".

General <i>Single</i>		Frequency Range	Output	Edit Marker	X
Frequency 1	1.000 000 000 000 GHz	<input checked="" type="checkbox"/>	Frequency 6	3.000 000 000 000 GHz	<input checked="" type="checkbox"/>
Frequency 2	4.500 000 000 000 GHz	<input checked="" type="checkbox"/>	Frequency 7	1.000 000 000 000 GHz	<input type="checkbox"/>
Frequency 3	2.100 000 000 000 GHz	<input type="checkbox"/>	Frequency 8	1.000 000 000 000 GHz	<input type="checkbox"/>
Frequency 4	1.000 000 000 000 GHz	<input type="checkbox"/>	Frequency 9	1.000 000 000 000 GHz	<input type="checkbox"/>
Frequency 5	1.000 000 000 000 GHz	<input type="checkbox"/>	Frequency 10	1.000 000 000 000 GHz	<input type="checkbox"/>
Marker Polarity			Active Marker		
Normal			3 - 2100000000.00 Hz		

You can define up to 10 markers, and assign one of them to the output at a time. When the sweep run has reached the marker frequency, the R&S SMA100B activates the marker signal and supplies it at the Marker User1 connector. The duration of the active signal corresponds to the dwell time of a step.

**Settings**

Frequency x ..... 198  
 State ..... 198  
 Marker Polarity ..... 199  
 Active Marker ..... 199

**Frequency x**

Sets the frequency that the selected marker indicates.

When the specified value is used, the polarity of the marker signal changes, as selected with the parameter .

Remote command:

```
[ :SOURce<hw> ] :SWEep [ :FREQuency ] :MARKer<ch> :FREQuency on page 689
```

**State**

Enables the selected marker.

A marker signal at the output connector marks the moment the specified frequency values is used.

Remote command:

```
[ :SOURce<hw> ] :SWEep [ :FREQuency ] :MARKer<ch> :FSTate on page 689
```

**Marker Polarity**

Sets the polarity of the marker signal.

The duration of the active signal is equal to the dwell time of a step.

Remote command:

`[ :SOURce<hw> ] :SWEep:MARKer:OUTPut:POLarity` on page 688

**Active Marker**

Boosts a specific marker signal so that it is output with higher voltage than all other markers.

Remote command:

`[ :SOURce<hw> ] :SWEep [ :FREQuency ] :MARKer:ACTive` on page 689

## 7.6 List Mode Settings

The "List Mode" dialog contains all the functions and settings for creating and handling lists with RF frequency/level pairs including the corresponding dwell times for generating the RF signal based on these values.

Access:

- ▶ Select "Sweep" > "List mode".

The dialog contains parameters for configuring the list mode processing, entering list mode data and transferring data files from or to the instrument.

The remote commands required to define these settings are described in [Chapter 14.16.7, "SOURce:LIST Subsystem"](#), on page 645.

- [General Settings](#)..... 200
- [List Mode Data Settings](#)..... 202
- [Import/Export Settings](#)..... 203

## 7.6.1 General Settings

Access:

- ▶ Select "Sweep" > "List mode".

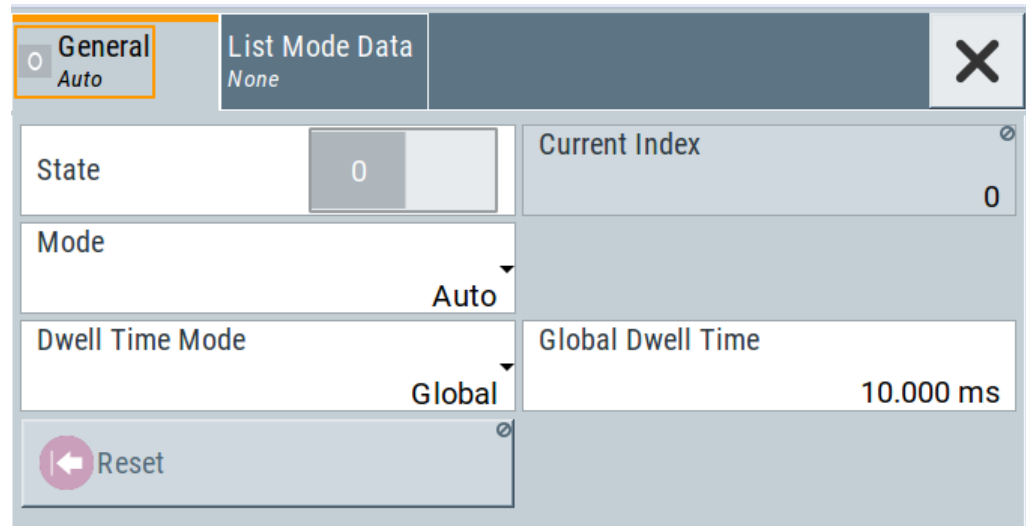

In the "General" tab, you can configure the trigger and dwell time modes for list processing and activate signal generation.

### Settings

State .....	200
Current Index .....	200
Mode.....	201
Dwell Time Mode.....	201
Global Dwell Time.....	201
Trigger Slope.....	201
Reset .....	202
Execute Single.....	202

### State

Activates the list mode and processes the currently selected list.

**Note:** Active RF frequency, RF level or RF combined sweep modes deactivate the LF sweep or List mode and vice versa.

Remote command:

[ :SOURce<hw> ] :FREQuency:MODE on page 625

### Current Index

Sets the list index for list processing in "Step" mode. In the other modes, the index indicates the current step.

Remote command:

[ :SOURce<hw> ] :LIST:INDEX on page 650

**Mode**

Selects the mode for list processing.

See [Chapter 7.1, "Signal Generation and Triggering in the Sweep and List Modes"](#), on page 171.

"Auto" Generates the signal by processing the frequency/level value pairs of the list from the beginning to the end.  
The list steps are performed automatically, controlled by the dwell time. If you switch from any mode to "Auto", signal generation always starts at the top of the list.

"Single / Extern Single"

Generates the signal by processing the frequency/level value pairs of the list once from the beginning to the end after a trigger event.  
The list steps are performed automatically, controlled by the dwell time. If one cycle is completed, the instrument waits for the next trigger event.

"Step / Extern Step"

Generates the signal by processing the frequency/level value pairs of the list step-by-step, manually triggered.

Remote command:

`[ :SOURce<hw> ] :LIST:TRIGger:SOURce` on page 652

`[ :SOURce<hw> ] :LIST:MODE` on page 651

**Dwell Time Mode**

Selects either variable dwell times or a fixed dwell time to perform signal generation in list mode.

"Global" Uses the same dwell time for all lists steps, set with [Global Dwell Time](#).

"From List" Uses the dwell times from the list.  
You can define the dwell time for each frequency/level value pair individually, see [Chapter 7.7, "List Editor"](#), on page 205.

Remote command:

`[ :SOURce<hw> ] :LIST:DWELL:MODE` on page 648

**Global Dwell Time**

Sets the dwell time for [Dwell Time Mode](#) > "Global".

**Note:** In case of considerable overrun conditions, the R&S SMA100B turns off the list mode.

See also ["Dwell time"](#) on page 184.

Remote command:

`[ :SOURce<hw> ] :LIST:DWELL` on page 648

**Trigger Slope**

For "Mode = Extern Step/Single", selects the polarity of the active slope of an applied instrument trigger.

Trigger signal is expected at the Inst Trig connector.

"Positive" The rising edge of the trigger signal triggers the instrument.

"Negative" The falling edge of the trigger signal triggers the instrument.

Remote command:

[\[:SOURce\]:INPut:TRIGger:SLOPe](#) on page 632

### Reset

Resets the list to the starting point.

Remote command:

[\[:SOURce<hw>\]:LIST:RESet](#) on page 654

### Execute Single

Manually starts list processing in "Single" mode.

Remote command:

[\[:SOURce<hw>\]:LIST:TRIGger:EXECute](#) on page 652

## 7.6.2 List Mode Data Settings

Access:

1. Select "Sweep" > "List mode".
2. Select "List Mode Data".

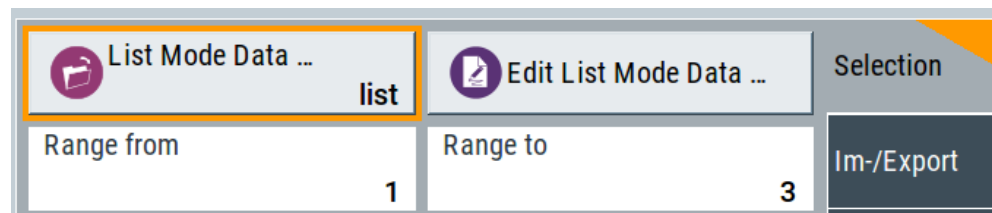

This dialog contains the parameters required for creating and editing lists, activating the learning function and selecting the list processing mode.

### Settings

<a href="#">List Mode Data</a> .....	202
<a href="#">Edit List Mode Data</a> .....	203
<a href="#">List Range from/to</a> .....	203

### List Mode Data

Accesses the standard "Select List" dialog for selecting, creating and editing a list file. The currently loaded file is indicated.

You can create data lists with the internal editor or import externally created files, see ["Creating and handling lists"](#) on page 183.

Remote command:

[\[:SOURce<hw>\]:LIST:CATalog?](#) on page 653

[\[:SOURce<hw>\]:LIST:SElect](#) on page 655

[\[:SOURce<hw>\]:LIST:DElete](#) on page 653

[\[:SOURce<hw>\]:LIST:DElete:ALL](#) on page 654

**Edit List Mode Data**

Opens the editor to insert and save data lists with RF frequency, power and dwell time values, see [Chapter 7.7, "List Editor"](#), on page 205.

You find this function also in standard file select dialog, accessed via [List Mode Data](#) .

**List Range from/to**

Defines an index range in the current list by setting the start and stop index.

The instrument generates the signal with the values of the selected index range and ignores all other list entries.

Remote command:

`[ :SOURce<hw> ] :LIST:INDEX:START` on page 650

`[ :SOURce<hw> ] :LIST:INDEX:STOP` on page 650

**7.6.3 Import/Export Settings**

Access:

1. Select "Sweep" > "List Mode".
2. Select "List Mode Data" > "Im-/Export".

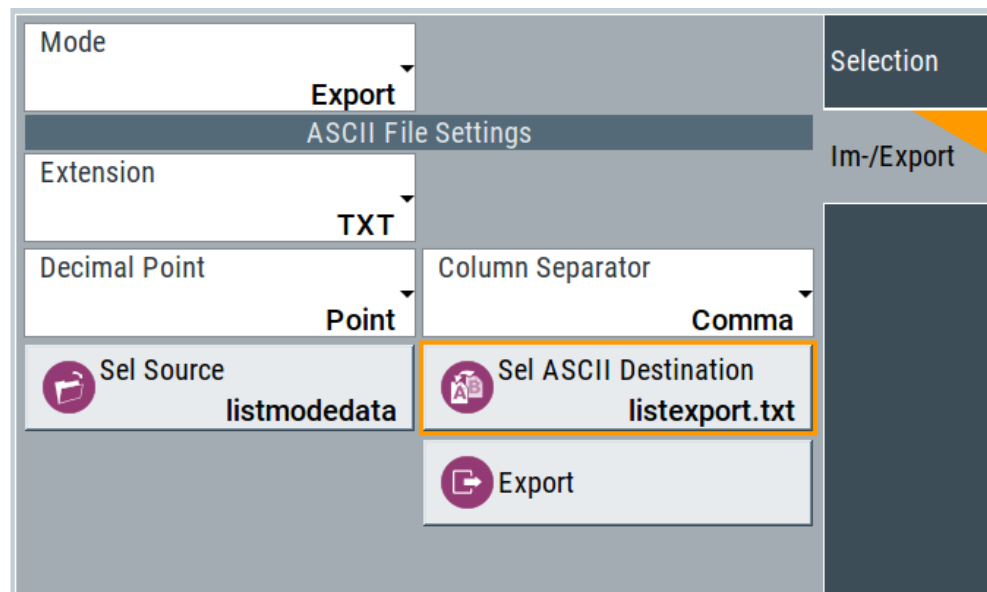

The "Im-/Export" dialog provides the parameters for importing or exporting files with user data in standard ASCII \*.txt or \*.csv file format.

The table separators and the decimal floating point numbers are customizable.

**Settings**

Mode .....	204
ASCII File Settings.....	204
Select (ASCII) Source/Select (ASCII) Destination.....	204
Select Source/Select ASCII Destination.....	205
Import / Export.....	205

**Mode**

Selects import or export of a data list file. The provided parameters vary according to the selected mode.

Remote command:

[ :SOURce<hw> ] :LIST:DEXChange:MODE on page 657

[ :SOURce<hw> ] :CORRection:DEXChange:MODE on page 624

[ :SOURce<hw> ] :PULM:TRAIIn:DEXChange:MODE on page 572

**ASCII File Settings**

Defines the format and the separators of the associated data file.

"Extension"       Selects \*.csv or \*.txt format.

"Decimal           Sets "Point" (dot) or "Comma" as the decimal separator used in the  
Point"            ASCII data with floating-point numerals.

"Column Separator"  
                    Sets the separator between the columns in an ASCII table.  
                    Available are: "Tab", "Semicolon", "Comma" or "Space".

Remote command:

[ :SOURce<hw> ] :LIST:DEXChange:AFIle:EXTeNsion on page 656

[ :SOURce<hw> ] :LIST:DEXChange:AFIle:SEParator:DECimal on page 656

[ :SOURce<hw> ] :LIST:DEXChange:AFIle:SEParator:COLumn on page 656

[ :SOURce<hw> ] :CORRection:DEXChange:AFIle:EXTeNsion on page 622

[ :SOURce<hw> ] :CORRection:DEXChange:AFIle:SEParator:DECimal  
on page 623

[ :SOURce<hw> ] :CORRection:DEXChange:AFIle:SEParator:COLumn

on page 623

[ :SOURce<hw> ] :PULM:TRAIIn:DEXChange:AFIle:EXTeNsion on page 572

[ :SOURce<hw> ] :PULM:TRAIIn:DEXChange:AFIle:SEParator:DECimal

on page 573

[ :SOURce<hw> ] :PULM:TRAIIn:DEXChange:AFIle:SEParator:COLumn

on page 573

**Select (ASCII) Source/Select (ASCII) Destination**

In "Mode > Import", access the file select dialog that provides standard file handling functions.

Where:

- "Select ASCII Source": defines the file to be loaded (imported)
- "Select ASCII Destination": selects the filename under that the loaded file is saved



Remote command:

[ :SOURce<hw> ] :LIST:DEXChange:AFILe:CATalog? on page 655  
 [ :SOURce<hw> ] :LIST:DEXChange:AFILe:SElect on page 656  
 [ :SOURce<hw> ] :CORRection:DEXChange:AFILe:CATalog? on page 622  
 [ :SOURce<hw> ] :CORRection:DEXChange:AFILe:SElect on page 623  
 [ :SOURce<hw> ] :PULM:TRain:DEXChange:AFILe:CATalog? on page 573  
 [ :SOURce<hw> ] :PULM:TRain:DEXChange:AFILe:SElect on page 573

### Select Source/Select ASCII Destination

In "Mode > Export", access the file select dialog that provides standard file handling functions.

Where:

- "Select Source": selects the file to be exported
- "Select ASCII Destination": defines the filename and the file path for the exported file

Remote command:

[ :SOURce<hw> ] :LIST:DEXChange:SElect on page 657  
 [ :SOURce<hw> ] :CORRection:DEXChange:SElect on page 624  
 [ :SOURce<hw> ] :PULM:TRain:DEXChange:SElect on page 574

### Import / Export

Imports or exports the selected data list file, depending on the current mode.

Remote command:

[ :SOURce<hw> ] :LIST:DEXChange:EXECute on page 656  
 [ :SOURce<hw> ] :CORRection:DEXChange:EXECute on page 623  
 [ :SOURce<hw> ] :PULM:TRain:DEXChange:EXECute on page 574

## 7.7 List Editor

The "User Correction" and "List Mode" dialogs provide a build-in list editor for defining the corresponding value pairs.

The table and navigation functions of the UCOR and list mode editors have the same structure and are therefore summarized below. The access is specified for both modes, the fields and functions are explained using the example of the list mode.

Access to "Edit List Mode Data":

- ▶ "Sweep" > "List Mode" > "List Mode Data" > "Edit List Mode Data"

The editor for list mode provides a table with RF frequency and power values, an extra column for defining variable dwell times, and standard navigation functions.

	Frequency /Hz	Power /dBm	Dwell Time /s
0	1 000 000 000.000	-20.00	0.001 000
1	540 000 000.000	-5.00	0.015 000
2	4 800 000 000.000	10.00	0.002 000
3	4 200 000 000.000	25.00	0.020 000
4	4 200 000 000.000	25.00	1.000 000
5	3 600 000 000.000	-15.00	0.500 000
6			

Go To Edit Save As ... Save

The remote commands required to define the list mode data are described in [Chapter 14.16.7, "SOURCE:LIST Subsystem"](#), on page 645.

Access to "Edit User Correction Data":

- ▶ "Level" > "User Correction" > "Edit User Cor. Data"

	Frequency /Hz	Correction Value /dB
0	1 560 000 000.00	11.51
1	1 561 000 000.00	11.03
2	1 562 000 000.00	10.55
3	1 563 000 000.00	10.07
4	1 564 000 000.00	9.59
5	1 565 000 000.00	9.11
6		

Go To Edit Fill with Sensor ... Save As ... Save

The editor for user correction data provides a table with RF frequency and power values and standard navigation functions.

The remote commands required to define the user correction data are described in [Chapter 14.16.3, "SOURCE:CORRection Subsystem"](#), on page 616.



All columns in a row must contain values. Cells with missing values are therefore filled automatically, using the value of the previous row.

If you use **global dwell time in list mode**, consider also that the instrument uses the value set with [Global Dwell Time](#) for all list steps and not the values from the list.

Since the table and navigation functions can be assumed to be known, the following description contains a brief overview, shown by the example of the "Edit List Mode Data" dialog. If a function relates to a particular dialog, it is explicitly stated.

### Settings

Edit List Mode Data.....	207
Data handling keys .....	207
L Go To.....	207
L Edit.....	208
L Fill with Sensor.....	208
L Save As/Save.....	208
Fill.....	208

### Edit List Mode Data

Table with values for list or user correction processing.

**Note:** Once you enter a value, the editor automatically adds preset values in the other columns. This functionality protects against data loss, otherwise incomplete rows are lost when saving. You can simply override these values.

"Frequency /Hz"

Sets the frequency values.

Remote command:

[ :SOURce<hw> ] :LIST:FREQuency on page 649

[ :SOURce<hw> ] :CORRection:CSET:DATA:FREQuency on page 619

"Power /dBm" (list mode data table)

Sets the level values.

Remote command:

[ :SOURce<hw> ] :LIST:POWer on page 651

"Correction Value /dBm" (user correction data table)

Sets the level values.

Remote command:

[ :SOURce<hw> ] :CORRection:CSET:DATA:POWer on page 619

"Dwell /s"

In list mode, sets the dwell time values.

Remote command:

[ :SOURce<hw> ] :LIST:DWELL:LIST on page 649

### Data handling keys

Standard functions for file and data handling.



### Go To ← Data handling keys

Selects a row for editing.

**Edit ← Data handling keys**

Enables you to insert, or delete a row or ranges within a list, and provides access to a dialog for automatic filling, see " Fill... " on page 106.

**Fill with Sensor ← Data handling keys**

Opens a dialog to configure the automatic filling of user correction data with an R&S NRP power sensor. Available in UCOR mode only.

See [Chapter 8.3.3, "Fill with Sensor"](#), on page 224

**Save As/Save ← Data handling keys**

Stores the list in a file with user-defined name and predefined file extension. To save a copy or create a file, use the "Save as" function.

**Fill...**

Provides parameters for filling a table automatically with user-defined values.

From 0	Range 4
Column To Fill Frequency /Hz	
Start Value 2.000 000 000 000 GHz	End Value 2.600 000 000 000 GHz
Increment Value 200.000 000 000 MHz	
<input checked="" type="checkbox"/> Fill	

To fill the table, select "Fill".

**Note:** Once you enter a value or fill a column, the editor automatically adds preset values in the other columns. This functionality protects against data loss, otherwise incomplete rows will be lost when saving. You can simply override these values.

"From / Range"

Defines the start line and number of lines to be filled.

"Column To Fill"

Selects, if the column is filled up with frequencies in Hz, levels in dBm or dwell times in s.

"Start Value / End Value"

Sets the start value for frequency, level or dwell time. The end value is read only and depends on the increment value and the range.

"Increment Value"

Determines the step size.

"Fill"

Fills the column specified in "Column To fill".

## 7.8 How to Generate a Signal in List or Sweep Mode

This section shows you how to configure a varying RF output signal for both, the list and sweep modes.

### To configure the frequency sweep signal

- ▶ For a step-by-step description, see [Chapter 3.3.2, "Generating an RF Frequency Sweep Signal"](#), on page 50.

### Example: Fast changing frequency and level settings in list mode

The following example shows you how to generate an amplitude modulated RF signal based on list mode data.

#### General workflow

Since any change of the hardware settings or list entries can affect the RF signal characteristics directly, we recommend that you proceed as follows:

1. Configure the modulation settings.  
Activate the RF signal.
2. Wait until the hardware settings have settled.
3. Create a list file.
4. Configure the list mode.
5. Activate list mode.

### To configure amplitude modulation and switch RF on

1. Press [Preset] to start from an initial state.
2. Select "Modulation" > "Amplitude Modulation > On".
3. Select "Level" > "RF ON" to activate RF signal generation.

### To create list mode data

1. Select "Sweep" > "List Mode".
2. In the "List Mode Data" tab, select "List Mode Data > New"
3. Enter the filename `ListMode_Test` for the data list and confirm with "Ok".  
The instrument creates a file and stores it in the `/var/user/` directory.
4. Select "Edit List Mode Data".
5. Enter the first values "Frequency > 2", "Power > 0" and "Dwell > 2".
6. Enter further frequency, power and dwell time values in the same way.
7. Select "Save" and close the dialog.

**To configure the list mode and start signal generation**

1. In the "General" tab, select "List Mode > Auto".
2. Select "Dwell Time Mode > From List".
3. Switch state to "On".
4. Select "General > State > On".

The instrument continuously generates an amplitude-modulated RF signal whose frequency and level values change according to the dwell times, as defined in the list.

With active list mode, the generator displays no frequency and level values in the status bar, but you can check the following parameters.

- In the list mode dialog, the current index indicates the steps of the signal generation.
- In remote control mode, you can query:
  - The current state with `[ :SOURCE<hw> ] :LIST:RUNNING?`
  - Current parameters with the commands `FREQ?`, `POW?` and `LIST:DWEL?`.

## 8 Improving Level Performance

To adjust the RF output signal to specific needs in your application, the R&S SMA100B offers different functions:

- **Attenuator**

The R&S SMA100B is equipped with a step attenuator that enables you to vary the amplitude of the RF signal in a wide range. It is characterized by low VSWR (voltage standing wave ratio) over the full level and frequency range, and provides highest level accuracy and noise suppression.

See ["About the attenuator"](#) on page 211.

- **Automatic Level Control (ALC)**

The automatic level control system ensures stable RF signals with highest absolute level accuracy over temperature and time.

See ["About ALC"](#) on page 214.

- **User correction (UCOR)**

The user correction function allows you to compensate frequency responses of external setups (e.g. losses of cables) and achieve a stable input signal over frequency directly at the DUT.

See ["About UCOR"](#) on page 217.

- **Power sensors**

The R&S SMA100B has excellent absolute level accuracy. Since a DUT is rarely connected directly to the generator, but with cables or other components, the reference level shifts from the RF output to the DUT. To calibrate this level with high accuracy, i.e. in the tenth dB range, you can connect an R&S NRP power sensor to the generator. The power sensor transmits its readings to the generator, which indicates these measurement results in the display. Thus you can adjust the RF output power of the generator until you reach the target level at the DUT.

See [Chapter 8.4, "Using Power Sensors"](#), on page 228

### 8.1 Attenuator

#### About the attenuator

The step attenuator is either an electronic or a mechanical device. Instruments with frequency options up to 20 GHz use an electronic step attenuator, providing fast and wear free level settings. Instruments capable to generate higher frequency signals use mechanical step attenuators. Depending on the frequency range and the installed high-power option, both types of step attenuators can be built in, and you can select the type to be used below 20 GHz.

To achieve a consistent level setting behavior for all frequencies, the mechanical step attenuator is used even for lower frequencies while the electronic one is disregarded. Especially in frequency ramp sweep mode, which requires a consistent level adjustment behavior, the R&S SMA100B automatically activates the mechanical step attenuator and disables the selection of the electronic step attenuator.

According to the requirements of your application, you can select different attenuator characteristics.

The following are examples of test requirements and the corresponding configuration:

- Automatic configuration  
Select standard operation mode ("Auto"), in which the generator adjusts the attenuation of the RF output signal automatically.
- DUT tests under low signal to noise conditions  
Low output power is suitable to test the behavior of a DUT under low signal to noise conditions.
- Uninterrupted level settings with constant VSWR  
A fix attenuation value is required for obtaining uninterrupted level settings with constant VSWR.  
The configuration "RF Off Mode > Unchanged" ensures that constant VSWR is maintained if you turn the signal off and on again.
- Noise sensitive applications  
The parameter "RF OFF Mode > Full Attenuation" sets maximum attenuation and thus suppresses noise when you turn off the RF signal.

### 8.1.1 Attenuator Settings

Access:

- ▶ Select "Level" > "Level > Attenuator".

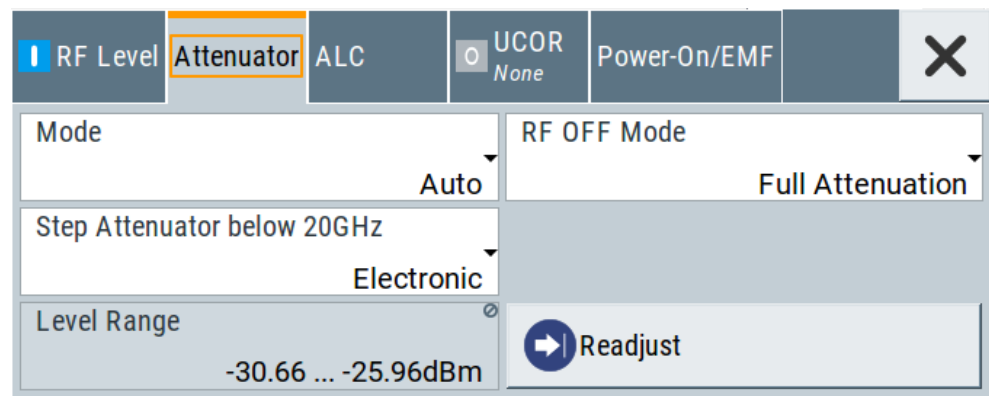

In the "Attenuator" dialog, you can select the operating mode of the electronic step attenuator.

The remote commands required to define these settings are described in [Chapter 14.13, "OUTPut Subsystem"](#), on page 474 and [Chapter 14.16.11, "SOURce:POWer Subsystem"](#), on page 662.



**Settings**

Mode .....	213
Step Attenuator below 20 GHz.....	213
Level Range .....	213
RF OFF Mode .....	213

**Mode**

Determines the operating mode of the step attenuator.

- "Auto" Adjusts the attenuator settings automatically.
- "Fixed" Fixes the attenuator and amplifier paths for the current RF level and provides signal output with constant output VSWR. The resulting level range is indicated under " [Level Range](#) " on page 213.

Remote command:

[:OUTPut<hw>:AMODE](#) on page 475

**Step Attenuator below 20 GHz**

Selects the type of the step attenuator for frequencies up to 20 GHz.

This setting depends on the frequency range and the installed high power options, see "[About the attenuator](#)" on page 211.

- "Mechanical" Selects that the R&S SMA100B uses the mechanical step attenuator over the whole frequency range. The mechanical attenuator is used even for lower frequencies, to achieve a consistent level setting behavior for all frequencies. The electronic step attenuator is disregarded. [Sweep Type > Ramp](#) also requires a consistent level adjustment behavior. Therefore, the R&S SMA100B automatically activates the mechanical step attenuator and disables the selection of the electronic step attenuator.
- "Electronic" Selects that the R&S SMA100B uses the electronic attenuator as long as the frequency is below 20 GHz, providing benefits regarding setting time and wear.

Remote command:

[\[:SOURce<hw>\]:POWER:ATTenuation:PATTenuator](#) on page 664

**Level Range**

Shows the interruption-free range of the level that you can use in the selected mode.

Remote command:

[:OUTPut<hw>:AFIXed:RANGe:LOWer?](#) on page 477

[:OUTPut<hw>:AFIXed:RANGe:UPPer?](#) on page 477

**RF OFF Mode**

Determines the state of the step attenuator, when the RF signal is switched off.

The setting is not affected by an instrument preset ([Preset] key or \*RST) and the "Save/Recall" function. It is reset only by factory preset.

"Unchanged" Freezes the setting of the step attenuator. Use this mode if a constant VSWR (Voltage Standing Wave Ratio) is required.

"Full Attenuation" Switches to the maximum attenuation. Use this mode for applications that require a high level of noise suppression.

Remote command:

`[[:SOURce<hw>]:POWER:ATTenuation:RFOff:MODE` on page 664

### 8.1.2 Reverse Power Protection

The R&S SMA100B is equipped with a reverse power protection circuit.

The reverse power protection is tripped when the power of signals reflected from the load or external signals applied to the RF output get too high. A relay opens and interrupts the internal connection to the RF output. This condition is indicated in the status bar by the "Overload" status message.

#### Overload

If an "Overload" status message is indicated in the status bar, perform the following:

- Remove the cause for the overload
- Press the [RF on/off] key to reset the overload protection

The RF input is activated when the overload protection is reset.

Remote command:

`:OUTPut<hw>:PROTection:TRIPped?` on page 478

`:OUTPut<hw>:PROTection:CLEar` on page 477

## 8.2 Automatic Level Control (ALC)

The R&S SMA100B is equipped with an automatic level control (ALC) unit to obtain best RF level accuracy.

#### About ALC

ALC is an adaptive control system to stabilize the RF output level. It continuously monitors the current level and adjusts it to keep a steady state over temperature and time.

ALC is active in almost all applications by default. However, when **pulse modulation** with short pulses is used, the ALC uses table-based level settings with table values depending on the pulse width.

Also note that ALC can detect incorrect values in **multi-transmitter** test setups. If multiple generators are coupled, reverse power can affect the ALC readings, which leads to an incorrect RF output power.

### ALC states and their effects

The following description basically explains the ALC states and their principle of operation:

- "Auto"  
Adjusts the output level to the operating conditions automatically. ALC is active in almost all operating modes.
- "On"  
Activates the internal level control permanently, regardless of the operating conditions.  
**Note:** This mode is not useful for pulse modulation with narrow pulses and low repetition rates, since the automatic level control can not settle in time. Set ALC "Table & On" instead.
- "Off (Table)"  
Deactivates internal level control loop. The instrument calculates every level setting using the attenuation values from the internal (ALC) table. Level attenuation between two table values is done with linear interpolation. This mode enables you to perform a fast and strictly monotonic, but not quite as precise level adjustment.
- "Table & On"  
Starts with the associated value of the internal level table and then activates the automatic level control. This mode achieves maximum level accuracy and fast setting times.  
If pulse modulation is applied, this mode ensures fast level settings even with narrow pulses at low repetition rate.

The R&S SMA100B displays the level control setting as a status message in the info line.

## 8.2.1 ALC Settings

Access:

- ▶ Select "Level" > "Automatic Level Control".

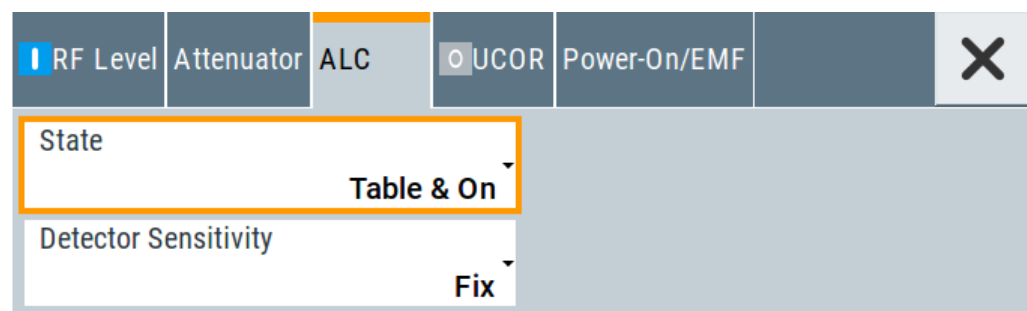

In the "ALC" dialog, you can configure the settings for the automatic level control of the RF signal to achieve optimal accuracy.

The remote commands required to define these settings are described in [Chapter 14.16.11, "SOURCE:POWER Subsystem"](#), on page 662.

**Settings**

<a href="#">State</a> .....	216
<a href="#">Detector Sensitivity</a> .....	216

**State**

Selects the internal level control mode.

"Auto"	Selects the most appropriate ALC mode automatically.
"On"	Activates ALC permanently.
"Off (Table)"	Controls the level using the attenuation values of the internal ALC table.
"Table & On"	Starts with the attenuation setting from the internal ALC table and continues with automatic level control.

For further details on the individual settings, an overview of the functionality and details on what is to be considered, see "[ALC states and their effects](#)" on page 215.

Remote command:

[\[:SOURCE<hw>\]:POWER:ALC\[:STATE\]](#) on page 663

**Detector Sensitivity**

Determines the path of the internal level detector.

The level detector of the ALC has multiple paths distinguished by their sensitivity.

"Auto"	Selects the detector path automatically, according to the given level. This mode is the recommended operation mode.
"Fix"	Fixes the last set sensitivity setting.

Remote command:

[\[:SOURCE<hw>\]:POWER:ALC:DSENSitivity](#) on page 663

## 8.3 User Correction

The R&S SMA100B supports a correction function to compensate external losses, caused, for example, by the RF cable, to achieve a precise target input level at the DUT.

The signal at the RF outputs of the R&S SMA100B is flat. However, the DUT is usually not connected directly to the outputs of the instrument but rather via connecting cables. Components like cables, power combiners, switches or mixers can affect the signal flatness at the DUT input.

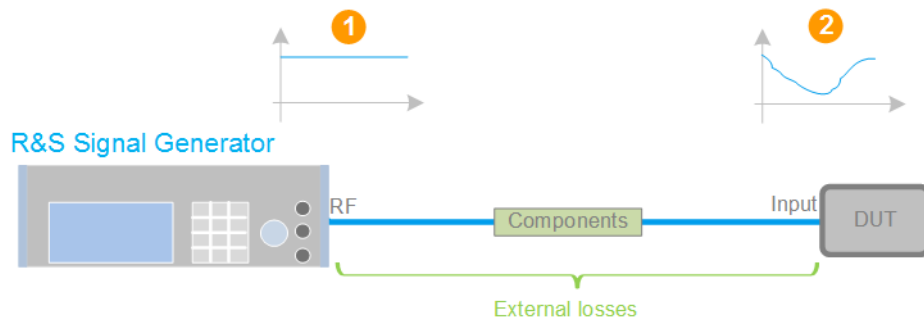

**Figure 8-1: Effect of external losses on the signal flatness at the DUT input**

- DUT = Device under test  
 Components = Designation of all components between the measurement equipment and the DUT, e.g. cables  
 1 = Flat signal at the outputs of the R&S SMA100B  
 2 = Signal received at the DUT, incl. the external losses

### About UCOR

User correction (UCOR) is a method that determines the external level loss over a frequency range in advance, see [Figure 8-2](#).

The difference between the generator output level and the level at the DUT determines the correction value at the respective frequency. Alternatively, the attenuation characteristics over a certain frequency range of, for example, RF cables are also specified in the associated data sheet.

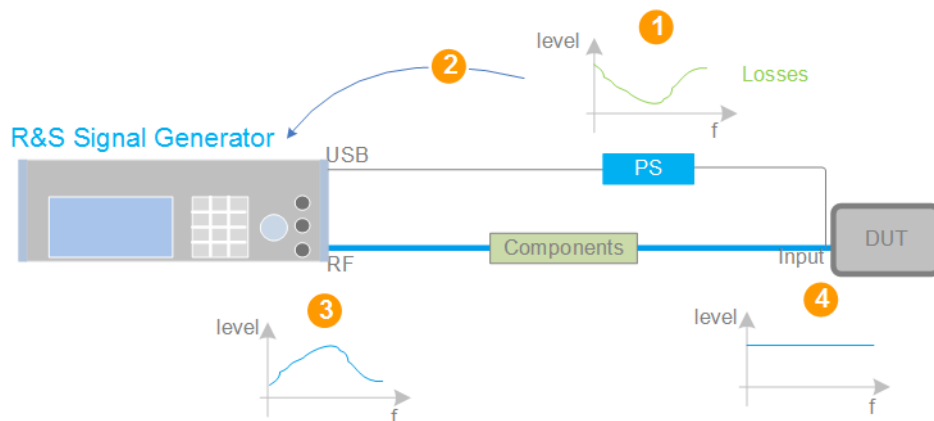

**Figure 8-2: Understanding the principle of user correction**

- DUT = Device under test  
 Components = Designation of all components between the measurement equipment and the DUT, e.g. cables  
 PS = Power sensor, e.g. R&S NRP, connected at the DUT's input and the USB connector of the R&S SMA100B  
 1 = Power sensor measures the level over a frequency range, where the collected values correspond to the losses caused by the components between the R&S SMA100B and the DUT

- 2 = Obtain the correction data by inverting the collected data; load the correction parameters in the R&S SMA100B
- 3 = In the R&S SMA100B, the RF signal is pre-processed with the correction values so that the signal at the outputs is the inverted version of the external losses
- 4 = Received at the DUT input, the pre-processed signal if flat

With active **UCOR**, the generator adds the correction value internally and thus increases the output level by exactly the amount of the loss between its output and the DUT. For frequencies which are not contained in the list, the level correction is calculated by interpolation of the closest correction values.

### Possible ways for configuring the user correction values

You can configure correction values in the following ways:

- **Internally**

- Use the built-in table editor in the "UCOR > Edit User Correction Data" dialog. Once defined, user correction values can be saved in a file. Files with correction data can be exported, for example, to exchange configuration between instruments or to modify the file content with an external program and reload them again.
- Using the corresponding remote-control commands. Note that you have to create a user correction file first.

- **Externally**

Create a file with correction values as a CSV file with Microsoft Excel, with a Notepad or a similar tool and save it with the predefined extension. Transfer the file to and load it into the instrument.

### UCOR file format

Files containing correction data are simple files in text or comma-separated value (CSV) file format. The filename is user-definable; the file extension is `*.ucor`.

The file contains a list of correction values, one row per frequency and correction value pair; a new line indicator separates the correction values.

For file handling, use the standard functions in the "File Manager", see [Chapter 11.8, "Using the File Manager"](#), on page 318.

### Collecting correction data

To fill the frequency and power values in the correction table, use one of the following options:

- **Manually**, row by row.
- Fill the table **automatically** with linearly interpolated values, calculated from value range and step size.
- Acquire the real frequency response characteristics of the used component with the **R&S NRP power sensor**, see [Understanding the principle of user correction](#).

### Using a power sensor for frequency response measurements

Consider the following when using R&S NRP power sensors to measure the correction values:

- Measure the level directly at the input of the DUT.
- Use the internal correction functions of an R&S NRP power sensor to increase the measurement accuracy.
- Use S-parameter to consider the impact of any two-port device like an adapter between the signal generator and the sensor input.



#### Interactions and characteristics

Activated user correction is effective in all operating modes.

The RF output level ( $Level_{RF}$ ) is the sum of the level value and the correction for the particular frequency:

$$Level_{RF} = \text{"Status bar > Level"} + \text{"UCOR"}$$

Activated user correction is indicated by the status indication "Lev Ucor" in the "Level" file.

### 8.3.1 User Correction Settings

Access:

1. Select "Level" > "User Correction".
2. If you already have created a file with user correction data:
  - a) Select "UCOR Data > navigate to the file \*.uco > Select".
  - b) Proceed with [step 4](#).
3. If you need to create a file:
  - a) Select "UCOR Data > New".
  - b) Enter the filename `UCOR_Data` and confirm with "Ok".
  - c) Choose the file and confirm with "Select".
  - d) Select "Edit UCOR Data".
  - e) To fill the user correction data table, proceed as described in [Chapter 7.7, "List Editor"](#), on page 205.
4. Select "RF Level > RF State > On".

5. Select "User Cor. Data > State > On".

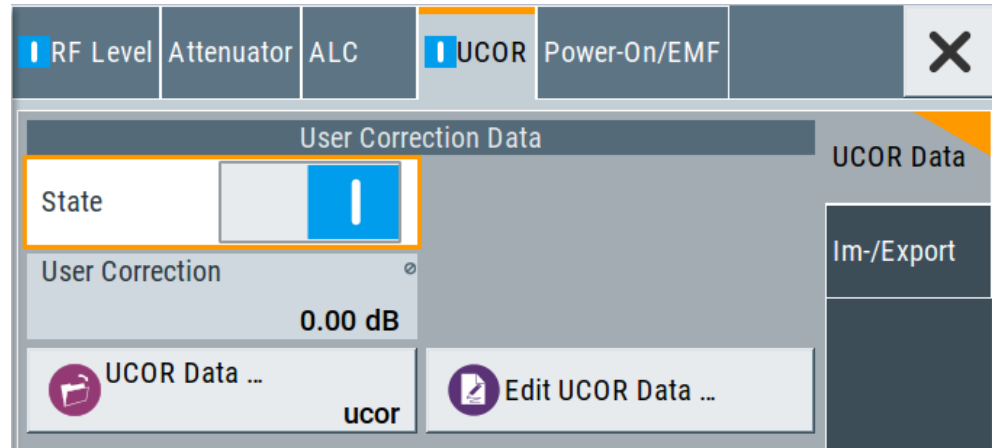

The "UCOR" dialog contains all settings for creating and handling files with user-defined level correction values.

The remote commands required to define these settings are described in [Chapter 14.16.3, "SOURce:CORRection Subsystem"](#), on page 616.

### Settings

State.....	220
User Correction.....	220
UCOR Data.....	220
Edit UCOR Data.....	221

### State

Activates user correction.

The R&S SMA100B displays the status icon "Lev Ucor" in the "Level" panel.

Remote command:

`[ :SOURce<hw> ] :CORRection [ :STATe ]` on page 621

### User Correction

Indicates the corrected level value for a specific frequency point.

Remote command:

`[ :SOURce<hw> ] :CORRection:VALue?` on page 620

### UCOR Data

Accesses the standard "File Select" function of the instrument. The provided navigation possibilities in the dialog are self-explanatory.

Files with user correction values are files with predefined file extension `*.uco`. When a file is selected, the dialog indicates the filename.

You can create the file internally in the table editor or externally.

- To select an existing file, select "Select List > navigate to the file \*.uco > Select"
- Use the general editor function to create internally new file or to edit an existing one.



- Use the standard file manager function to load externally created files to the instrument.

Remote command:

[ :SOURce ] :CORRection:CSET:CATaLog? on page 621

[ :SOURce<hw> ] :CORRection:CSET [ :SElect ] on page 620

[ :SOURce ] :CORRection:CSET:DELeTe on page 622

### Edit UCOR Data

Opens the build-in table editor to define a new correction table or edit an existing one.

See also:

- [Chapter 7.7, "List Editor"](#), on page 205
- [" Fill... "](#) on page 106
- [Chapter 8.3.3, "Fill with Sensor"](#), on page 224

## 8.3.2 List Editor

The "User Correction" and "List Mode" dialogs provide a build-in list editor for defining the corresponding value pairs.

The table and navigation functions of the UCOR and list mode editors have the same structure and are therefore summarized below. The access is specified for both modes, the fields and functions are explained using the example of the list mode.

Access to "Edit List Mode Data":

- ▶ "Sweep" > "List Mode" > "List Mode Data" > "Edit List Mode Data"

The editor for list mode provides a table with RF frequency and power values, an extra column for defining variable dwell times, and standard navigation functions.

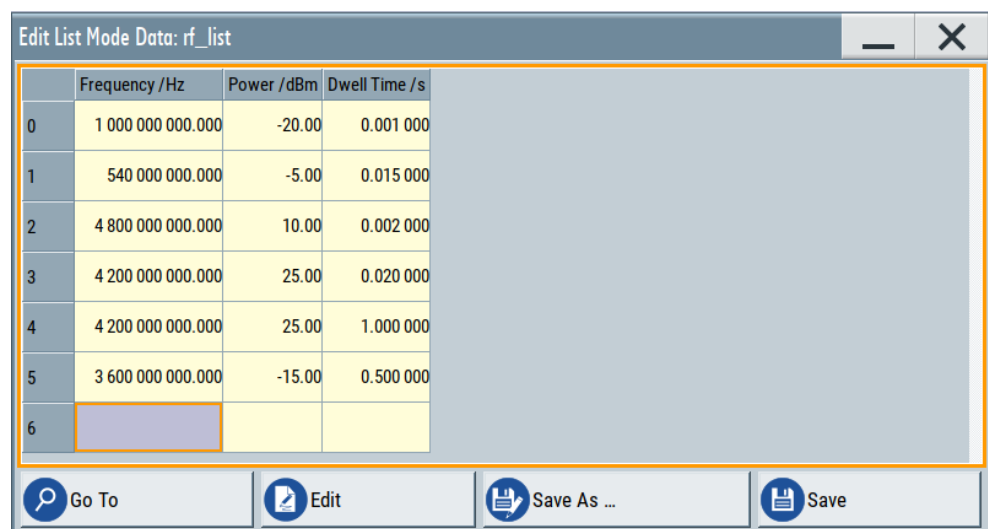

	Frequency /Hz	Power /dBm	Dwell Time /s
0	1 000 000 000.000	-20.00	0.001 000
1	540 000 000.000	-5.00	0.015 000
2	4 800 000 000.000	10.00	0.002 000
3	4 200 000 000.000	25.00	0.020 000
4	4 200 000 000.000	25.00	1.000 000
5	3 600 000 000.000	-15.00	0.500 000
6			

The remote commands required to define the list mode data are described in [Chapter 14.16.7, "SOURCE:LIST Subsystem"](#), on page 645.

Access to "Edit User Correction Data":

- ▶ "Level" > "User Correction" > "Edit User Cor. Data"

	Frequency /Hz	Correction Value /dB
0	1 560 000 000.00	11.51
1	1 561 000 000.00	11.03
2	1 562 000 000.00	10.55
3	1 563 000 000.00	10.07
4	1 564 000 000.00	9.59
5	1 565 000 000.00	9.11
6		

The editor for user correction data provides a table with RF frequency and power values and standard navigation functions.

The remote commands required to define the user correction data are described in [Chapter 14.16.3, "SOURCE:CORrection Subsystem"](#), on page 616.



All columns in a row must contain values. Cells with missing values are therefore filled automatically, using the value of the previous row.

If you use **global dwell time in list mode**, consider also that the instrument uses the value set with [Global Dwell Time](#) for all list steps and not the values from the list.

Since the table and navigation functions can be assumed to be known, the following description contains a brief overview, shown by the example of the "Edit List Mdoe Data" dialog. If a function relates to a particular dialog, it is explicitly stated.

### Settings

<a href="#">Edit List Mode Data</a> .....	222
<a href="#">Data handling keys</a> .....	223
L <a href="#">Go To</a> .....	223
L <a href="#">Edit</a> .....	223
L <a href="#">Fill with Sensor</a> .....	223
L <a href="#">Save As/Save</a> .....	223
<a href="#">Fill...</a> .....	223

### Edit List Mode Data

Table with values for list or user correction processing.

**Note:** Once you enter a value, the editor automatically adds preset values in the other columns. This functionality protects against data loss, otherwise incomplete rows are lost when saving. You can simply override these values.

"Frequency /Hz"

Sets the frequency values.

Remote command:

[ :SOURce<hw> ] :LIST:FREQuency on page 649

[ :SOURce<hw> ] :CORRection:CSET:DATA:FREQuency on page 619

"Power /dBm" (list mode data table)

Sets the level values.

Remote command:

[ :SOURce<hw> ] :LIST:POWer on page 651

"Correction Value /dBm" (user correction data table)

Sets the level values.

Remote command:

[ :SOURce<hw> ] :CORRection:CSET:DATA:POWer on page 619

"Dwell /s"

In list mode, sets the dwell time values.

Remote command:

[ :SOURce<hw> ] :LIST:DWELL:LIST on page 649

### Data handling keys

Standard functions for file and data handling.



#### Go To ← Data handling keys

Selects a row for editing.

#### Edit ← Data handling keys

Enables you to insert, or delete a row or ranges within a list, and provides access to a dialog for automatic filling, see " Fill... " on page 106.

#### Fill with Sensor ← Data handling keys

Opens a dialog to configure the automatic filling of user correction data with an R&S NRP power sensor. Available in UCOR mode only.

See [Chapter 8.3.3, "Fill with Sensor"](#), on page 224

#### Save As/Save ← Data handling keys

Stores the list in a file with user-defined name and predefined file extension. To save a copy or create a file, use the "Save as" function.

#### Fill...

Provides parameters for filling a table automatically with user-defined values.

From 0	Range 4
Column To Fill Frequency /Hz	
Start Value 2.000 000 000 000 GHz	End Value 2.600 000 000 000 GHz
Increment Value 200.000 000 000 MHz	
<input checked="" type="checkbox"/> Fill	

To fill the table, select "Fill".

**Note:** Once you enter a value or fill a column, the editor automatically adds preset values in the other columns. This functionality protects against data loss, otherwise incomplete rows will be lost when saving. You can simply override these values.

"From / Range"

Defines the start line and number of lines to be filled.

"Column To Fill"

Selects, if the column is filled up with frequencies in Hz, levels in dBm or dwell times in s.

"Start Value / End Value"

Sets the start value for frequency, level or dwell time. The end value is read only and depends on the increment value and the range.

"Increment Value"

Determines the step size.

"Fill"

Fills the column specified in "Column To fill".

### 8.3.3 Fill with Sensor

Access:

1. Select "Level" > "User Correction".
2. Select "UCOR Data > navigate to the file \*.ucor > Select".

3. Select "Edit UCOR Data > Fill With Sensor...".

This dialog contains parameters for filling a table automatically with sensor readings.



To fill the table, select "Execute".

For information on power sensors and how to use them, see [Chapter 8.5, "How to Calibrate the Power Level with an R&S NRP Power Sensor"](#), on page 284.

## Settings

<a href="#">Fill User Correction Data with Sensor</a> .....	225
<a href="#">Used SMAB Settings For Measurement</a> .....	226

### Fill User Correction Data with Sensor

- "Sensor"  
Displays connected sensors for selection.
- "List To Fill"  
Indicates the used list.
- "Use SParameter"  
Indicates whether SParameter correction in the R&S NRP power sensor is used.
- "Include Zeroing"  
Performs a zeroing procedure before acquiring the user correction data to improve precision.  
No signal is applied to the sensor during zeroing. RF output is temporarily switched off during that time.  
When unchecked, the zeroing procedure is skipped. However, the RF signal level might be blanked shortly. This setting is useful if blanking of RF is undesirable or the absence of power at the sensor cannot be guaranteed.
- "Execute"

The "Execute" button is only enabled if a sensor is detected and the user correction list contains at least one frequency value.

Remote command:

`[ :SOURce<hw> ] :CORRection:ZERoing:STATe` on page 621

`[ :SOURce<hw> ] :CORRection:CSET:DATA [ :SENSor<ch> ] [ :POWER ] :SONCe`  
on page 620

#### Used SMAB Settings For Measurement

Displays the settings relevant for the measurement.

"Modulation" Indicates the modulation state

"Amplitude" Shows the currently set level.

Remote command:

n.a.

### 8.3.4 Import/Export List Files

Access:

1. Select one of the following:
  - "Sweep" > "List mode".
  - "Level" > "User Correction".
  - "Modulation > Pulse Modulation > Pulse Generator > Pulse Mode = Train".
2. Select "Import/Export".

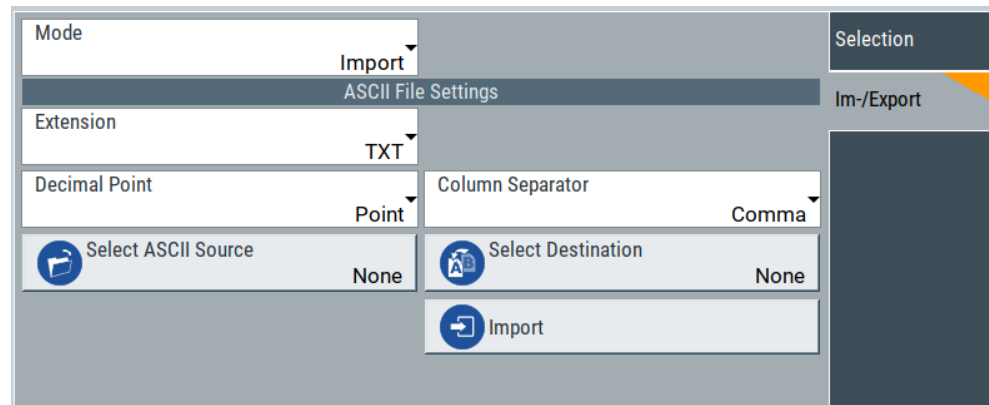

Figure 8-3: Im-/Export dialog (example with UCOR settings)

The "Import/Export" dialog contains all functions and settings to import externally created list data or to export it accordingly. You can process and store a list in the formats `*.txt` (ASCII), or `*.csv` (plain text with identical sequence of fields). The table separators and the decimal floating point numbers are customizable.

## Settings

Mode .....	227
ASCII File Settings.....	227
Select (ASCII) Source/Select (ASCII) Destination.....	227
Select Source/Select ASCII Destination.....	228
Import / Export.....	228

## Mode

Selects import or export of a data list file. The provided parameters vary according to the selected mode.

Remote command:

[ :SOURce<hw> ] :LIST:DEXChange:MODE on page 657

[ :SOURce<hw> ] :CORRection:DEXChange:MODE on page 624

[ :SOURce<hw> ] :PULM:TRAIIn:DEXChange:MODE on page 572

## ASCII File Settings

Defines the format and the separators of the associated data file.

"Extension"        Selects \*.csv or \*.txt format.

"Decimal            Sets "Point" (dot) or "Comma" as the decimal separator used in the  
Point"              ASCII data with floating-point numerals.

"Column Separator"  
                      Sets the separator between the columns in an ASCII table.  
                      Available are: "Tab", "Semicolon", "Comma" or "Space".

Remote command:

[ :SOURce<hw> ] :LIST:DEXChange:AFIle:EXTeNsion on page 656

[ :SOURce<hw> ] :LIST:DEXChange:AFIle:SEParator:DECimal on page 656

[ :SOURce<hw> ] :LIST:DEXChange:AFIle:SEParator:COLumn on page 656

[ :SOURce<hw> ] :CORRection:DEXChange:AFIle:EXTeNsion on page 622

[ :SOURce<hw> ] :CORRection:DEXChange:AFIle:SEParator:DECimal  
on page 623

[ :SOURce<hw> ] :CORRection:DEXChange:AFIle:SEParator:COLumn  
on page 623

[ :SOURce<hw> ] :PULM:TRAIIn:DEXChange:AFIle:EXTeNsion on page 572

[ :SOURce<hw> ] :PULM:TRAIIn:DEXChange:AFIle:SEParator:DECimal  
on page 573

[ :SOURce<hw> ] :PULM:TRAIIn:DEXChange:AFIle:SEParator:COLumn  
on page 573

## Select (ASCII) Source/Select (ASCII) Destination

In "Mode > Import", access the file select dialog that provides standard file handling functions.

Where:

- "Select ASCII Source": defines the file to be loaded (imported)
- "Select ASCII Destination": selects the filename under that the loaded file is saved

Remote command:

[ :SOURce<hw> ] :LIST:DEXChange:AFILe:CATalog? on page 655  
 [ :SOURce<hw> ] :LIST:DEXChange:AFILe:SElect on page 656  
 [ :SOURce<hw> ] :CORRection:DEXChange:AFILe:CATalog? on page 622  
 [ :SOURce<hw> ] :CORRection:DEXChange:AFILe:SElect on page 623  
 [ :SOURce<hw> ] :PULM:TRain:DEXChange:AFILe:CATalog? on page 573  
 [ :SOURce<hw> ] :PULM:TRain:DEXChange:AFILe:SElect on page 573

### Select Source/Select ASCII Destination

In "Mode > Export", access the file select dialog that provides standard file handling functions.

Where:

- "Select Source": selects the file to be exported
- "Select ASCII Destination": defines the filename and the file path for the exported file

Remote command:

[ :SOURce<hw> ] :LIST:DEXChange:SElect on page 657  
 [ :SOURce<hw> ] :CORRection:DEXChange:SElect on page 624  
 [ :SOURce<hw> ] :PULM:TRain:DEXChange:SElect on page 574

### Import / Export

Imports or exports the selected data list file, depending on the current mode.

Remote command:

[ :SOURce<hw> ] :LIST:DEXChange:EXECute on page 656  
 [ :SOURce<hw> ] :CORRection:DEXChange:EXECute on page 623  
 [ :SOURce<hw> ] :PULM:TRain:DEXChange:EXECute on page 574

## 8.4 Using Power Sensors

The R&S SMA100B works with most of the R&S NRP power sensors and thus supports various application tasks. Using power sensors, you can for example determine attenuation characteristics of downstream equipment or cables. You can use the measured values to compensate the losses with internal control functions or with an external control circuit in real time.

R&S NRP sensors are highly accurate standalone measuring devices, suitable for a wide range of applications. The devices communicate directly with the signal generator, calculate the average or peak power internally, include S-parameter correction and return the measurement results to the generator.

The R&S SMA100B works with any sensor of the R&S NRP series and can perform up to four power measurements simultaneously.

Only for the NRP-Z power analysis function, you have to use R&S NRP power sensors that support power analysis in frequency, power and time domain, see [Chapter 8.4.4.1, "Required Options"](#), on page 240





Check the firmware version of the R&S NRP sensors regularly. Update the firmware, if necessary.

For updates, see the Rohde & Schwarz website <http://www.rohde-schwarz.com> in section "Power Meters & Voltmeters".

- [Connecting R&S NRP Power Sensors to the R&S SMA100B](#)..... 229
- [NRP Sensor Mapping](#)..... 230
- [NRP Power Viewer](#)..... 233
- [NRP-Z Power Analysis](#)..... 240

### 8.4.1 Connecting R&S NRP Power Sensors to the R&S SMA100B

R&S NRP sensors are connected to the R&S SMA100B in the following ways:

- Connection to the Sensor connector
  - R&S NRP-ZK8 (eight-pole interface cable) for R&S NRPxx power sensors
  - R&S NRP-ZK6 (six-pole interface cable) for R&S NRPxx power sensors
  - No additional cable for R&S NRP-Zxx power sensors (cable is fixed on the sensor)
- Connection to the USB connector
 

Requires the following cables, depending on the used sensor type:

  - R&S NRP-ZKU (USB interface cable) for R&S NRPxx power sensors
  - R&S NRP-Z3 or R&S NRP-Z4 (USB adapter cables) for sensors of the R&S NRP-Zxx family
- Connection via R&S NRP-Z5 sensor hub
 

The R&S NRP-Z5 USB sensor hub (high-speed USB 2.0) can host up to 4 R&S NRP sensors. It provides simultaneous internal and external triggering of all connected sensors.

Requires additional cables, depending on the used output connector of the hub. Choose one of the following:

  - Short extension cable R&S NRP-Z2 for connection to the sensor connector. This six-pole connection provides the external trigger capability.
  - Standard USB cable (USB type A to USB type B) to any USB type A connector of the R&S SMA100B. This connection does not support external triggering.
- Connection via USB hub with external power supply unit
 

Requires the following cables, depending on the used sensor type:

  - R&S NRP-ZKU (USB interface cable) for R&S NRPxx power sensors
  - R&S NRP-Z3 or R&S NRP-Z4 (USB adapter cables) for sensors of the R&S NRP-Zxx family
- Connection via LAN for R&S NRPxxxSN/xxxTN/xxxAN power sensors
 

Using the Ethernet interface requires PoE (Power over Ethernet) to provide the electrical power.

To establish the connection, you can use:

  - A PoE Ethernet switch, e.g. R&S NRP-ZAP1 and an RJ-45 Ethernet cable.

- A PoE injector and an RJ-45 Ethernet cable.

For details, see the description R&S®NRP®Series Power Sensors Getting Started.

### Detection and mapping

The R&S SMA100B automatically detects a connected R&S NRP power sensor and indicates it in the "NRP Power Viewer" and "NRP Sensor Mapping" dialogs.

By default, detected sensors are indicated as follows:

- A sensor connected at the Sensor socket is assigned as "Sensor 1".  
If no sensor is connected to this socket, channel 1 remains unassigned.
- Sensors 2 to 4 are assigned to the sensors at the USB connectors, according to their sequence of connection.

You can change the default mapping in the [NRP Sensor Mapping](#) dialog.



On connection, the R&S SMA100B immediately starts the measurement of a detected R&S NRP power sensor. If you perform an instrument preset ([Preset] key or \*RST), the R&S SMA100B stops the measurements. The connection and the mapping of the power sensors remain, the measurements must be restarted.

## 8.4.2 NRP Sensor Mapping

The "NRP Sensor Mapping" lists all R&S NRP sensors detected by the instrument.

Any R&S NRP sensor that supports the USB legacy protocol and is connected to one of the USB interfaces, is detected automatically and added to the list. Vice versa, the R&S SMA100B removes a sensor from the list, when it is disconnected.

R&S NRP sensors that are connected via LAN or use the USBTMC protocol are not automatically detected. They are detected by the scan search function.

Access:

- ▶ Select "Clk Syn/Power Sens" > "NRP Sensor Mapping".

Sensor Name	Protocol	Connector	Mapping
1 NRP40TN-100999	Visa		
2 NRQ6-900037	Visa		

Scan

Add Sensor

IP Address or Host Name  
NRQ6-900037

Device ID or Sensor Name  
NRQ6 Serial Number  
900037

The dialog lists all detected R&S NRP sensors for selection and mapping. You can also browse the network for sensors.

The detected sensors are characterized by the used protocol and the corresponding connector icon. In the "Mapping" column, you can assign the sensor to one of the available sensor channels. The list can contain several entries but the R&S SMA100B can only use up to four sensors simultaneously.

The remote commands required to define these settings are described in [Chapter 14.15, "SENSe, READ, INITiate and SLISt Subsystems"](#), on page 527.

## Settings

<a href="#">Sensor Mapping List</a> .....	231
<a href="#">Scan</a> .....	232
<a href="#">Clear</a> .....	232
<a href="#">Add Sensor/Hide 'Add Sensor'</a> .....	232
<a href="#">Add Sensor settings</a> .....	232
L <a href="#">Add LAN Sensor settings</a> .....	232
L <a href="#">Add USB Sensor settings</a> .....	232

## Sensor Mapping List

Displays a list of all sensor entries with information on the sensor name, the used protocol, the connector and the assigned mapping.

If a sensor is connected via LAN or uses the USBTMC protocol, its protocol is indicated as "Visa".

Remote command:

:SLISt[:LIST]? on page 531

:SLISt:ELEMent<ch>:MAPPing on page 533

:SLISt:SENSor:MAP on page 533

**Scan**

Scans the network and the USB connections for sensors connected using the VISA communication protocol, i.e. sensors that are addressed over LAN or USBTMC.

The instrument detects sensors communicating over the USB legacy protocol automatically.

Remote command:

`:SLIST:SCAN[:STATe]` on page 531

**Clear**

Adds the ID parameter of a detected sensor to the list of sensors.

**Add Sensor/Hide 'Add Sensor'**

Shows or hides the "Add Sensor" settings.

**Add Sensor settings**

Configures settings to add sensors connected to the R&S SMA100B via USB or LAN.

**Add LAN Sensor settings ← Add Sensor settings**

Configures settings to add sensors connected to the R&S SMA100B via LAN.

"IP Address or Host Name" Displays the host name or the IP address of a R&S NRP power sensor.  
If the R&S SMA100B does not detect a connected R&S NRP sensor, you can assign the address information manually.

"Add LAN Sensor" Adds a detected R&S NRP sensor connected in the LAN to the list of sensors, including its device ID or name and its serial number.

Remote command:

`:SLIST:SCAN:LENSor` on page 531

**Add USB Sensor settings ← Add Sensor settings**

Configures settings to add sensors connected to the R&S SMA100B via USB.

"Device ID or Sensor Name" Displays the device identifier or the name of the R&S NRP power sensor.  
If the R&S SMA100B does not detect a connected R&S NRP sensor, you can assign the ID or name manually.

"Serial Number" Displays the serial number of the R&S NRP power sensor.  
If the R&S SMA100B does not detect a connected R&S NRP sensor, you can assign the serial number manually.

"Add USBTMC Sensor" Adds a detected R&S NRP sensor connected at the USB interface to the list of sensors, including its device ID or name and its serial number.

Remote command:

`:SLIST:SCAN:USENSor` on page 532

### 8.4.3 NRP Power Viewer

The R&S SMA100B features the power viewer function for measuring or monitoring signals with R&S NRP power sensors.

#### 8.4.3.1 About

The R&S SMA100B can perform up to four power measurements simultaneously.

Depending on the signal characteristic (CW, AM, pulsed, etc.) or the parameter to be measured (average, peak, etc...) a suitable R&S power sensor must be used.

#### **About the measuring principle, averaging filter, filter length, and achieving stable results**

A sensor measures the average or peak RF power of the source continuously. The measurement results are displayed in the "NRP Power Viewer" dialog.

The power viewer function uses **averaging filters** for getting a stable readout.

Measurement results could be interfered for instance by too much noise in your setup, by a bad suppression of harmonics or non harmonics or when you reach the sensitivity level of your power sensor.

Measurements are continuously repeated in a predefined time window. The measurement result is obtained by averaging the measured values for the last  $2N$  time windows. This approach is referred to as a **two-step averaging process**.

The factor of 2 in the formula arises because the output signals from the microwave detector are chopped at the same rate as the time windows to suppress low-frequency noise. An independent measured value can only be obtained from two consecutive values.

The variable  $N$  in the formula indicates the **filter length**. The filter length then directly influences the measurement time. The filter length can be selected automatically or it can be manually set to a fixed value.

Depending on the R&S NRP power sensor type, the manual setting of the filter length varies in resolution:

- Resolution = 1 for the R&S NRPxx power sensor family
- Resolution =  $2^n$  for R&S NRP-Zxx power sensors, with  $n = 1$  to 16

Follow the following general recommendation to find out the **optimum filter length**:

- Always start a measurement in auto mode ("Filter > Auto").  
Check if the measurement results are sufficient.
- If the power is not constant, select the filter length manually ("Filter > User").  
Trigger the "Auto Once" function to search for the optimum filter length for the current measurement conditions.  
The estimated value is indicated as filter length.
- If the target measurement accuracy value is known, select "Filter > Fixed Noise".  
The averaging factor is selected automatically and so that the sensor's intrinsic noise (two standard deviations) does not exceed the specified noise content.

- Different sensor types achieve the same filtering result with different filter and time window lengths.

The time window length depends on the sensor type:

- For most sensors, it is fixed to 20 ms.
- For the R&S NRP-Z81 sensor, it is 10  $\mu$ s.  
The R&S NRP-Z81 uses filter length that is 1000 times larger than the filter length for other sensors.

### About zeroing

Activates the auto zero function.

Zeroing calibrates the external power sensor by adjusting its reading at zero signal power. For this purpose, the RF power source must be switched off or disconnected from the sensor. If a Rohde & Schwarz power sensor receives an input power during the zeroing process, it aborts zeroing and generates an error message. Zeroing takes a few seconds, depending on the sensor model. Refer to the documentation of your power sensor for more information.

### Tips for zeroing

When to perform zeroing:

- During warm up after switching on or connecting the instrument
- After a substantial change of the ambient temperature
- After fastening the power sensor module to an RF connector at high temperature
- After several hours of operation
- When low-power signals are to be measured, e.g. less than 10 dB above the lower measurement limit.
- Switch off the RF power source for zeroing, but do not disconnect it from the power sensor. This proceeding keeps the thermal equilibrium, and the zeroing process also compensates the noise that superimposes the measured signal (e.g. from a broadband amplifier).

### Related settings and functions

- Measurements-related settings, like results, filter, filter length:  
[Chapter 8.4.3.2, "NRP Power Viewer Settings"](#), on page 235
- Software version of the connected power sensor:  
`:SENSe<ch>[:POWER]:TYPE?` on page 542
- Acquisition of level correction data:  
[Chapter 8.3, "User Correction"](#), on page 216

### Additional information

See Rohde & Schwarz website <http://www.rohde-schwarz.com> in section "Power Meters & Voltmeters" for:

- R&S NRP power sensor manual.
- Information on the R&S NRP-Z5 sensor hub and the available accessories.
- Sensor software updates.

### 8.4.3.2 NRP Power Viewer Settings

Access:

- ▶ Select "Clk Syn/Power Sens" > "NRP Power Viewer".

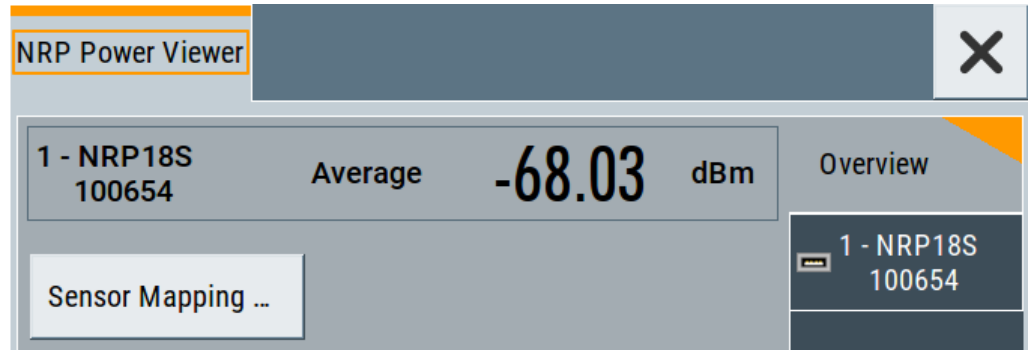

The "Overview" tab shows the list of detected sensors, and provides a separate tab per sensor.

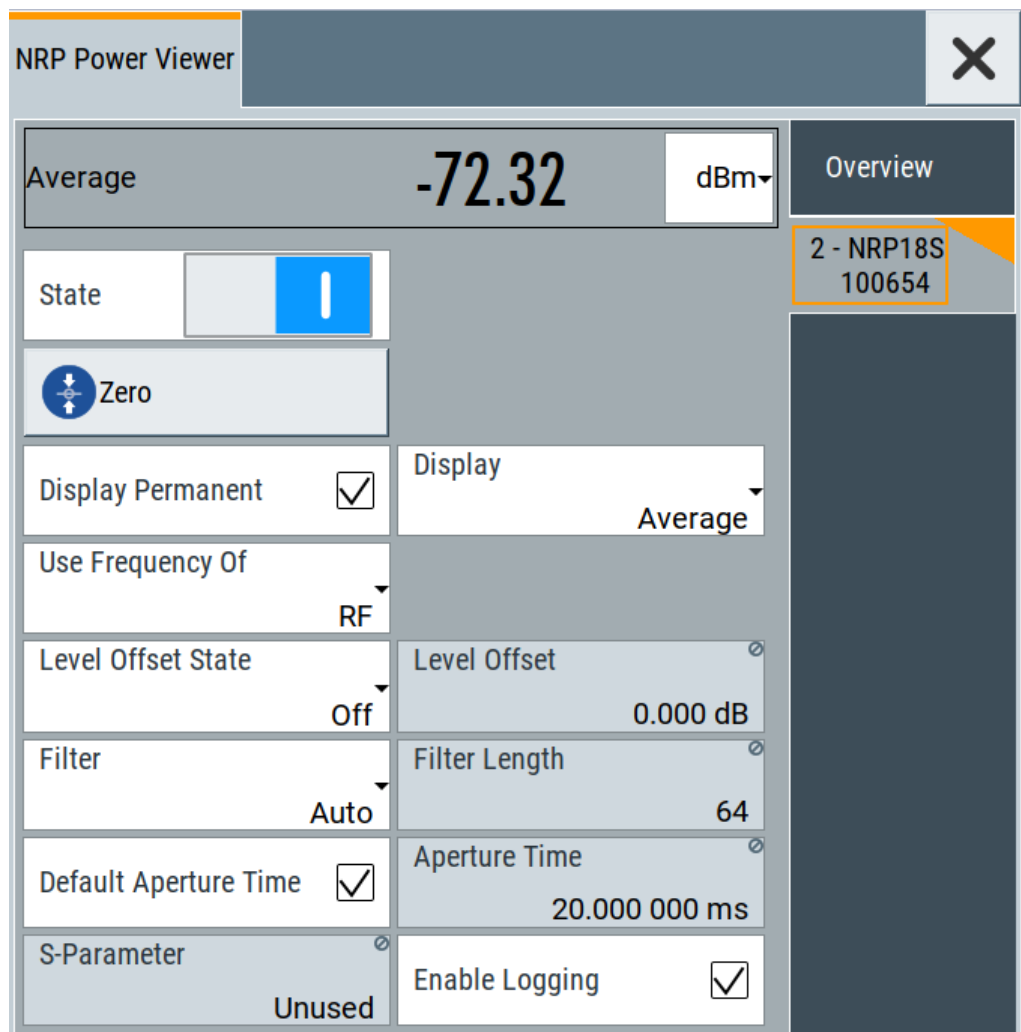

A sensor tab contains all parameters for configuring the sensor settings, like average or peak display, reference source, filter and level offset.

The remote commands required to define these settings are described in [Chapter 14.15, "SENSe, READ, INITiate and SLISt Subsystems"](#), on page 527, including the triggering of the measurement and the retrieval of measurement results.

See also [Chapter 8.5, "How to Calibrate the Power Level with an R&S NRP Power Sensor"](#), on page 284.

## Settings

Sensor type and serial number.....	236
Level (Peak) / Level (Average) .....	236
Sensor Mapping.....	237
Sensor settings.....	237
L State .....	237
L Zero .....	237
L Display.....	237
L Permanent .....	237
L Display .....	237
L Use Frequency Of.....	237
L Frequency .....	238
L Level Offset State,Level Offset.....	238
L Filter.....	238
L Filter Length.....	239
L Noise/Signal Ratio.....	239
L Auto Once.....	239
L Timeout.....	239
L Default Aperture Time.....	239
L Aperture Time.....	239
L S-Parameter .....	240
L Enable Logging.....	240

### Sensor type and serial number

Indicates the type and the serial number of a selected R&S NRP power sensor, and the channel the sensor is assigned to.

The displayed [Level \(Peak\) / Level \(Average\)](#) values correspond to the particular sensor.

Remote command:

`:SENSe<ch>[:POWER]:TYPE?` on page 542

`:SENSe<ch>[:POWER]:SNUMBER?` on page 540

### Level (Peak) / Level (Average)

Indicates the measured peak or average level value.

You can also change the unit for the results display: Watt, dBm or dBµV.

**Note:** Peak level measurements are provided if the power sensor supports this feature.

Remote command:

`:READ<ch>[:POWER]?` on page 534

`:SENSe<ch>:UNIT[:POWER]` on page 534



**Sensor Mapping**

Accesses the [NRP Sensor Mapping](#) dialog.

**Sensor settings**

One tab per sensor provides the corresponding settings.

**State ← Sensor settings**

Activates level measurement.

Remote command:

`:INITiate<hw>[:POWer]:CONTinuous` on page 484

To query the availability of a sensor at a given connector, use the command `:SENSe<ch>[:POWer]:STATus[:DEVice]?` on page 541.

**Zero ← Sensor settings**

Activates the auto zeroing.

For details, see ["About zeroing"](#) on page 234.

Remote command:

`:SENSe<ch>[:POWer]:ZERO` on page 542

**Display ← Sensor settings**

Sets the display mode for power readings.

**Permanent ← Display ← Sensor settings**

Activates the permanent indication of the power measurement result on the left side of the home screen.

You can activate the permanent display for several sensors.

Remote command:

`:SENSe<ch>[:POWer]:DISPlay:PERManent:STATe` on page 536

**Display ← Display ← Sensor settings**

Sets the display of results on mean or peak power.

Remote command:

`:SENSe<ch>[:POWer]:DISPlay:PERManent:PRIority` on page 536

**Use Frequency Of ← Sensor settings**

Selects the source for measurement.

"RF"

The R&S SMA100B transfers the RF frequency and level settings to the R&S power sensor automatically. Thus you achieve power readings of high accuracy, irrespective from the connected sensor type.

"User" Sets a user defined frequency.

**Example:**

If you have a frequency converting device between the generator and the DUT. If the frequency converter doubles the frequency, you can set twice the frequency in the R&S SMA100B. The R&S power sensor considers this RF frequency setting.

Set the parameter [Frequency](#) to the measurement's frequency.

Remote command:

[:SENSe<ch>\[:POWer\]:SOURce](#) on page 541

**Frequency ← Sensor settings**

Defines the frequency value if "Source > User" is used.

Remote command:

[:SENSe<ch>\[:POWer\]:FREQuency](#) on page 539

**Level Offset State,Level Offset ← Sensor settings**

Activates and defines a level offset which is considered in the power measurement result. The level offset value is always expressed in dB, irrespective of the display of the measurement result.

This function allows you to consider, for example, an attenuator in the signal path.

Remote command:

[:SENSe<ch>\[:POWer\]:OFFSet](#) on page 540

[:SENSe<ch>\[:POWer\]:OFFSet:STATe](#) on page 540

**Filter ← Sensor settings**

Selects the way the length of the used filter is defined.

See also ["About the measuring principle, averaging filter, filter length, and achieving stable results"](#) on page 233.

- "Auto" Selects the filter length automatically and adjusts it to the measured value. The value is indicated with the parameter [Filter Length](#).  
When high output power is applied, the filter length and therefore the measurement time can be short.  
When low output power is applied, the filter length and therefore the measurement time is increased which reduces the considered noise content in your measurement.
- "User" The filter length is defined manually, with the parameter [Filter Length](#). As the filter length works as a multiplier for the time window, constant filter length results in a constant measurement time.  
Values 1 and 2N are allowed.

"Fixed Noise" The averaging factor is taken automatically in accordance to the value [Noise/Signal Ratio](#). Thus, the sensor's intrinsic noise (2 standard deviations) does not exceed the specified noise content. To avoid long measurement times when the power is too low, set a [Timeout](#).  
Timeout is the maximum acceptable measurement time which limits the averaging factor and therefore leads to a more unstable readout.

Remote command:

`:SENSe<ch>[:POWER]:FILTer:TYPE` on page 539

#### **Filter Length ← Sensor settings**

Sets or indicates the filter length, depending on the selected filter mode.

- "Filter > Auto" indicates the automatically adjusted filter length.
- "Filter > User" enables you to set the filter length manually.
- "Filter > Fixed Noise" hides the setting parameter.

Remote command:

`:SENSe<ch>[:POWER]:FILTer:LENGTh:AUTO?` on page 537

`:SENSe<ch>[:POWER]:FILTer:LENGTh[:USER]` on page 537

#### **Noise/Signal Ratio ← Sensor settings**

For [Filter > Fixed Noise](#), sets the noise content.

Remote command:

`:SENSe<ch>[:POWER]:FILTer:NSRatio` on page 538

#### **Auto Once ← Sensor settings**

Searches the optimum filter length for the current measurement conditions. The result is indicated with the parameter [Filter Length](#).

See also "[About the measuring principle, averaging filter, filter length, and achieving stable results](#)" on page 233.

Remote command:

`:SENSe<ch>[:POWER]:FILTer:SONCe` on page 538

#### **Timeout ← Sensor settings**

For "Filter > Fixed Noise", sets a time limit for the averaging process.

Remote command:

`:SENSe<ch>[:POWER]:FILTer:NSRatio:MTIME` on page 538

#### **Default Aperture Time ← Sensor settings**

The sensor default setting is sufficient. Disable this parameter to specify a user-defined aperture time per sensor, if, for example, the readings vary.

To obtain stable readings, set the [Aperture Time](#) exactly to one modulation period.

Remote command:

`:SENSe<ch>[:POWER]:APERTure:DEFault:STATE` on page 535

#### **Aperture Time ← Sensor settings**

If "Use Default Aperture Time > Off", defines the acquisition time per sensor.

For example, to obtain a sufficient low average value, set the aperture time exactly to one modulation period.

Remote command:

`:SENSe<ch>[:POWer]:APERture:TIME` on page 535

#### **S-Parameter ← Sensor settings**

Lists the S-Parameter correction data files retrieved for the connected power sensor. To activate the correction data, select the corresponding file.

S-Parameter correction is used to mathematically shift the reference plane to the DUT by considering the S-parameters for any components connected upstream of the sensor.

The S-Parameter table can be changed with the S-Parameters tool, provided as part of the free R&S NRP Toolkit software. For more information, refer to the manual of the connected R&S NRP power sensor.

Remote command:

`:SENSe<ch>[:POWer]:CORRection:SPDevice:STATe` on page 536

`:SENSe<ch>[:POWer]:CORRection:SPDevice:LIST?` on page 536

`:SENSe<ch>[:POWer]:CORRection:SPDevice:SElect` on page 535

#### **Enable Logging ← Sensor settings**

Activates recording of R&S NRP power sensor readings in a log file.

There is 1 log file per sensor. The log files are created automatically and filled in continuously. They are text files with predefined filename `SensLog<n>.txt`, where `<n>` indicates the connected sensor. Log files are stored on the internal memory, in the directory `/var/user/SensorLogging`.

Each log file contains the measured value (2 readings when you work with peak sensors), the sensor type, and the measurement time (timestamp). Logged data is not overwritten. When a new measurement is started, the collected logging data is appended in the log file.

Check the used disc space regularly and remove log files to maintain storage capacity.

**Note:** The logging function is intended for measurements with long time intervals. It is suitable source for data reconstructions if the connection to the sensor was interrupted.

Remote command:

`:SENSe<ch>[:POWer]:LOGGing:STATe` on page 540

### **8.4.4 NRP-Z Power Analysis**

The "NRP-Z Power Analysis" functionality enables you to analyze the measured power of a DUT under frequency, power and time aspects, while the instrument supports you with marker, graphic and reference value functions.

#### **8.4.4.1 Required Options**

The "NRP-Z Power Analysis" requires the power analysis option installed on your instrument, and a sensor that supports power analysis.

R&S SMA100B base unit equipped with the following option:

- Power Analysis (R&S SMAB-K28)

R&S NRP power sensors:

- R&S NRP-Z8x, referred to in the following description
- R&S NRP-Z91
- R&S NRP-Z211

For more information, see data sheet.

#### 8.4.4.2 About

##### Characteristics and features of the NRP-Z power analysis function

The NRP-Z power analysis displays the measurement data graphically. The measurement diagram covers up to four traces you can manually or automatically assign to one or more connected power sensors. For evaluation of the readings, you can save a defined reference trace or even freeze a reading temporarily on the screen. Markers and mathematic functions enable you to compare particular values.

The NRP-Z power analysis supports three measurement modes:

- Power versus frequency (frequency response).  
For this mode, all required generator settings are automatically configured except for the power level. The power level setting of the generator is used for the frequency sweep measurements.  
The frequency sweep settings are transferred to the sensor to automatically calculate the correct measurement value for each frequency point.
- Power versus power (power sweep, AM/AM)  
Power sweep measurements are executed using the frequency settings of the generator. Alternatively, the sensor can be adjusted to a frequency different from the generator, see [Use Separate Frequency- Power Analysis](#) .  
This frequency is transmitted to the sensor to automatically calculate the correct measurement value.
- Power versus time (power measurement in the time domain, e.g. R&S NRP-Z8x trace mode).  
In the time mode, you can analyze the signal of the generator but also externally supplied signals. This mode requires an additional trigger event, with selectable level, hysteresis and drop time. Provided the sensor used supports the power measurement of pulse signals, you can also analyze pulse data in time domain.

##### Characteristics of pulse data



For R&S NRP-Z8x power sensors that support time domain analysis and automatic pulse analysis.

The power sensors enable pulse data analysis in measurement mode time. All important pulse parameters are measured after setting the threshold levels. The following graph shows most of these parameters:

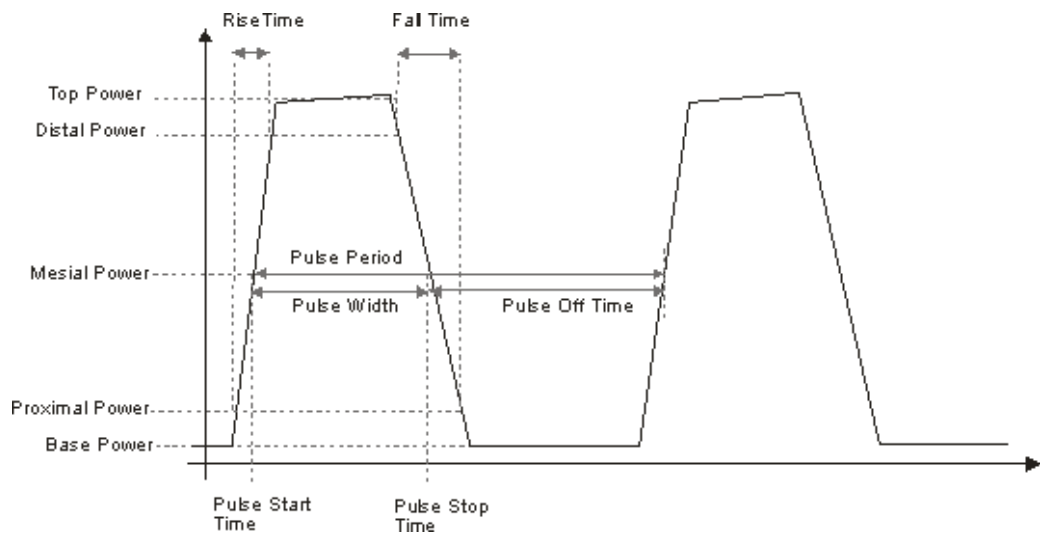

The sensor calculates the pulse parameters from each measurement and delivers the results to the R&S SMA100B.

The indication state of the parameters also affects the save function. Storing the measurement diagram as hardcopy includes the parameters selected in this dialog.



A total of 6 parameters can be indicated at one time. Structured hierarchically, trace 1 features top priority and trace 4 is addressed with the lowest weighting. This means that only the first 6 checked parameters are indicated, starting with the settings of trace 1.

The pulse data is only visible for certain zoom levels of the diagram.

### 8.4.4.3 Accessing the NRP-Z Power Analysis Functionality

Access:

- ▶ Select "Clk Syn/Power Sens" > "NRP-Z Power Analysis".

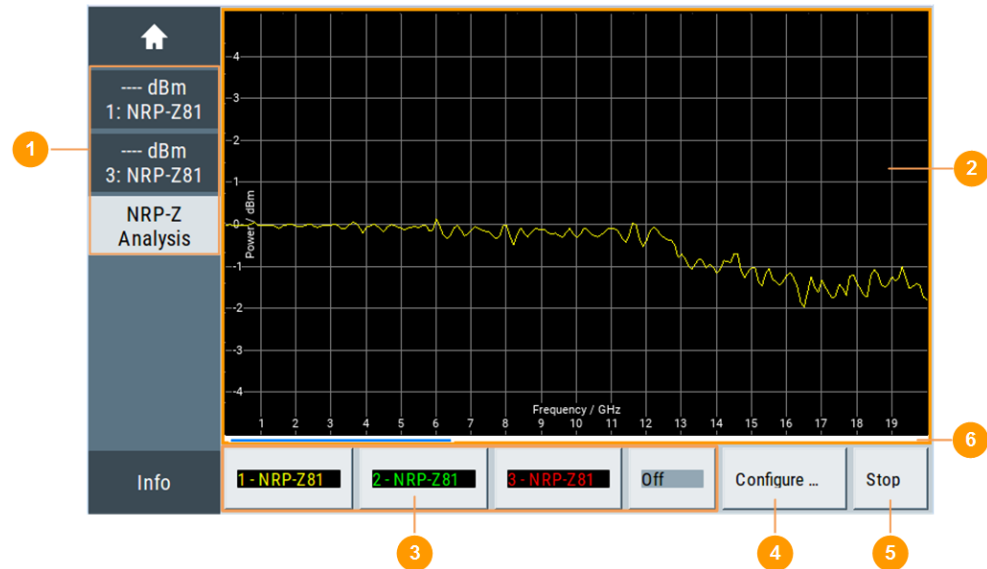

**Figure 8-4: Power analysis window**

- 1 = Buttons for accessing the "NRP Power Viewer" settings
- 2 = Power analysis diagram
- 3 = Buttons for accessing the traces/marker dialogs
- 4 = Buttons for accessing the configuration dialogs with measurement and sensor parameters
- 5 = "Start" button to trigger/stop the measurement
- 6 = "Progress bar" indicated during measurement

The start screen of the NRP-Z power analysis contains the measurement diagram and labelled buttons indicating connected power sensors. These buttons and a configuration button provide access to the dialogs for setting up the measurement and sensor parameters, for configuring the diagram and for the trace display. You can start or stop your measurement directly. During the measurement, the R&S SMA100B shows the progress of the measurement in the progress bar at the bottom of the diagram.

#### Context-sensitive menu

A context sensitive menu also provides access to the configuration dialogs and some additional functions.

Access:

- ▶ Touch and hold a spot in the power analysis diagram for at least 1 second to access the context- sensitive menu.

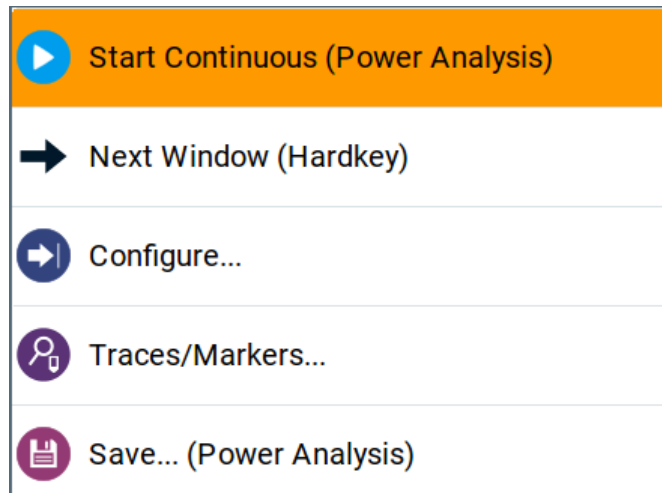

Figure 8-5: Power analysis context-sensitive menu

In the context-sensitive menu you can access:

- "Start Continuous/Stop": Triggers / stops the power analysis measurement  
**Note:** During a measurement in the frequency domain, or the power domain respectively, the displayed frequency/power value in the status bar (home screen) does not correspond to the value applied at the output. Therefore, the R&S SMA100B displays asterisks instead of the frequency or power value during the measurement and indicates the original value again when the measurement is completed or aborted.
- "Next Window (Hardkey)": Switches between the measurement views that are enabled in the following order:
  - "Standard View"
  - "Marker View"
  - "Pulse Data View"
  - "Full Screen"

At least one viewing mode has to be selected. For details on the different view modes, see ["Next Window List"](#) on page 270.

- "Configure...": opens a dialog for configuring the power analysis measurement. See [Chapter 8.4.4.6, "NRP-Z Configure Settings"](#), on page 250.
- "Trace/Markers...": opens a dialog for configuring the traces/marker. See [Chapter 8.4.4.5, "NRP-Z Traces/Markers Settings"](#), on page 245.
- "Save...(Power Analysis)": opens a dialog to save a hardcopy of the measurement. See [Chapter 8.4.4.7, "Creating Screenshots of Power Analysis Settings"](#), on page 274.

### Power Analysis Diagram

Indicates the measurement results graphically, including configured markers, functions, etc.



**Off / NRP-Zxx**

Accesses the dialogs for configuring the traces and markers, see [Chapter 8.4.4.5, "NRP-Z Traces/Markers Settings"](#), on page 245

**Configure...**

Accesses the dialog for configuring the power analysis measurement, see [Chapter 8.4.4.6, "NRP-Z Configure Settings"](#), on page 250.

**Start / Stop measurement**

Starts and stops the power analysis measurement. Depending on the selected measurement mode, the label varies.

**8.4.4.4 Test Setup Example**

As a power meter has no built-in selection, it is measuring all signal components from nearly DC to 40 GHz and higher. Therefore, the DUT's signal must be rather pure or subjected to external filtering (harmonics, spurious) before measured.

The test setup for the power analysis in the power versus frequency or power versus power is as follows:



**Figure 8-6:**

DUT = Device under test

PS = Power sensor, e.g. R&S NRP-Z8x, connected at the DUT's input and the USB connector of the R&S SMA100B

1. Connect the DUT RF input to the RF output of the instrument.
2. Connect the DUT RF output to the power sensor.
3. Connect the power sensor to the signal generator.
4. Select "Clk Syn/Power Sens" > "NRP-Z Power Analysis".
5. Select "Configure..." to open a dialog for setting up the measurement.
6. Select the power sensor, indicated at the bottom of the dialog to set the trace.
7. Select "Start Cont." to trigger the measurement.

**8.4.4.5 NRP-Z Traces/Markers Settings**

Access:

1. Select "Clk Syn/Power Sens" > "NRP-Z Power Analysis".
2. Select power sensor indication located at the bottom of the dialog.

- To access the trace settings, select the respective "Trace x" tab.

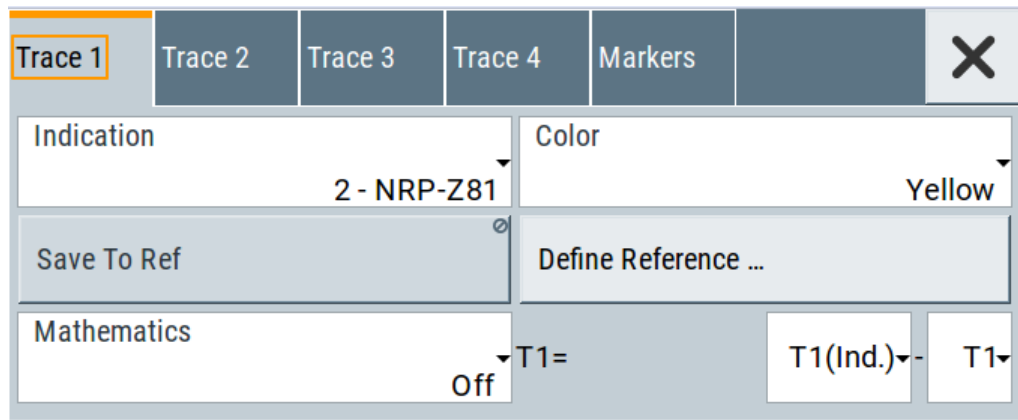

The measurement data can be current (sensor trace) or stored trace data. You can store data either in a file (reference trace) or in a temporary memory (hold trace). Up to four traces can be indicated at one time. On connection, the sensors are automatically detected and assigned to a trace. By default, connected sensors are assigned to the traces in ascending order, that means sensor 1 to trace 1, sensor 2 to trace 2, etc. If the default trace is already used, the sensor has to be assigned manually in the trace dialog.

Using the reference and hold traces, you can compare traces. Assign a reference curve to one trace and your measured values to a second one, and switch on the display. With this feature you can compare results directly in the graph, or show the deviations in a graph by using the "[Mathematics - Trace Power Analysis](#)" on page 248 function.

### Example

The current single measurement of sensor 2 which is assigned to trace 2 is used as reference trace.

- Select "Trace 2" with "Indication" = "2 - NRP-Z81".
- Select "Save To Ref".
- Select "Trace 1" > "Indication > Ref".
- Select "Diagram".

The R&S SMA100B indicates two identical traces.

- Select "Start single".

Triggers a new measurement cycle with sensor 2. You can compare the resulting measurement trace with the former measurement, which is displayed as reference trace.

## Traces Settings

### Indication - Trace Power Analysis

Selects the source for the trace data.

The selection is indicated on the trace button in the measurement diagram.

"Off"	No source is selected, the trace is not indicated.
"2 - NRP-Zxx"	The current measurement results of the selected power sensor are the source for the trace data. The index at the beginning of the sensor name indicates the used connector, for example "2" indicates that the sensor is connected via a USB interface. The data is either continuously updated (continuous measurement) or represents a single measurement cycle (single measurement).
"Ref"	Selects the reference trace. The reference trace is a static trace that was stored in a file and can be recalled. It is possible to store one reference trace at a time.
"Hold"	Freezes the current trace data. The hold trace is a temporary trace that is available until the power analysis is finished. Freezing the trace of a sensor in one trace and displaying the measurement values of the same sensor in another trace allows fast comparison between measurements.

Remote command:

[:TRACe<ch>\[:POWER\]:SWEep:STATe](#) on page 525

[:TRACe<ch>\[:POWER\]:SWEep:COpy](#) on page 519

[:TRACe<ch>\[:POWER\]:SWEep:FEED](#) on page 520

### Color - Trace Power Analysis

Selects the color of the trace.

Remote command:

[:TRACe<ch>\[:POWER\]:SWEep:COLOr](#) on page 518

### Save to Ref - Trace Power Analysis

Saves the selected trace as reference trace. Only one reference trace is available at a time.

Remote command:

[:TRACe<ch>\[:POWER\]:SWEep:COLOr](#) on page 518

### Define Reference - Trace Power Analysis

Opens a dialog for defining a linear reference curve.

### Freq (X) / Pow (Y) ← Define Reference - Trace Power Analysis

For [Configure Measurement Settings](#) > "Frequency", determines the parameters of the frequency reference curve.

Remote command:

[:SENSe\[:POWER\]:SWEep:FREQuency:REFEreNce:DATA:XVALues](#) on page 495

[:SENSe\[:POWER\]:SWEep:FREQuency:REFEreNce:DATA:YVALues](#) on page 496

**Pow (X) / Pow (Y) ← Define Reference - Trace Power Analysis**

For [Configure Measurement Settings](#) > "Power", sets the x- and y-axis values of the points A and B.

Remote command:

`:SENSe[:POWER]:SWEep:POWer:REFErence:DATA:XVALues` on page 508

`:SENSe[:POWER]:SWEep:POWer:REFErence:DATA:YVALues` on page 508

**Time (X) / Pow (Y) ← Define Reference - Trace Power Analysis**

For [Configure Measurement Settings](#) > "Time", sets the time values for the x-axis and the corresponding y-axis power values.

Remote command:

`:SENSe[:POWER]:SWEep:TIME:REFErence:DATA:XVALues` on page 513

`:SENSe[:POWER]:SWEep:TIME:REFErence:DATA:YVALues` on page 513

**Save To Ref ← Define Reference - Trace Power Analysis**

Saves the selected trace as reference trace. One reference trace is available at a time.

Remote command:

`:SENSe[:POWER]:SWEep:FREQuency:REFErence:DATA:COpy` on page 495

`:SENSe[:POWER]:SWEep:POWer:REFErence:DATA:COpy` on page 508

`:SENSe[:POWER]:SWEep:TIME:REFErence:DATA:COpy` on page 513

**Mathematics - Trace Power Analysis**

Activates the mathematic function.

The function enables you to determine the deviation of two test series, either of measurement traces, or also of traces that contain math results or stored reference curves. That means you can also assign a math result to an operand for further calculation. Various nested computation steps are possible.

The math operation follows the formula:

$$T\langle ch \rangle_{result} = T\langle ch \rangle_{Operand1} - T\langle ch \rangle_{Operand2}$$

How to proceed:

Determine  $T\langle ch \rangle_{Operand1}$  in the entry field next to "Tx", and then select  $T\langle ch \rangle_{Operand2}$  in the second entry field right to it.

The result (" $T\langle ch \rangle_{result}$ ") is assigned to the above selected "Trace". If switched on, the graph shows the resulting curve.

**Note:**

Depending on the type of trace, the instrument automatically sets the appropriate unit on the y-axis:

- "dBm" if it shows only measurement traces.
- "dB" for purely mathematical curves.
- "dB/dBm" ratio scale for mixed display, that means measurements and mathematical curves.

**Example:**

Example of a nested calculation.

- T1 shows the result of the subtraction of the trace ("Trace 1"), and the reference curve.
- Trace2 subtracts Ref from T1.  
That illustrates the nested calculation, since T1 covers already a math operation.  
**Note:** "(Ind.)" denotes the currently selected trace.

Remote command:

:CALCulate[:POWer]:SWEep:FREQuency:MATH<ch>:STATe on page 479

:CALCulate[:POWer]:SWEep:FREQuency:MATH<ch>:SUBTRACT on page 480

:CALCulate[:POWer]:SWEep:POWer:MATH<ch>:STATe on page 480

:CALCulate[:POWer]:SWEep:POWer:MATH<ch>:SUBTRACT on page 480

:CALCulate[:POWer]:SWEep:TIME:MATH<ch>:STATe on page 483

:CALCulate[:POWer]:SWEep:TIME:MATH<ch>:SUBTRACT on page 483

**Markers Settings**

Access:

1. Select "Clk Syn/Power Sens" > "NRP-Z Power Analysis".
2. Select power sensor indication located at the bottom of the dialog.
3. Select the "Markers" tab.

Trace 1	Trace 2	Trace 3	Trace 4	Markers	
Trace				1	Marker 1 Visible <input checked="" type="checkbox"/>
Trace				2	Marker 2 Visible <input checked="" type="checkbox"/>
Trace				1	Marker 3 Visible <input type="checkbox"/>
Trace				1	Marker 4 Visible <input type="checkbox"/>

This dialog comprises the markers settings display on the respective trace diagram.

**Marker x Visible - Power Analysis**

Selects if the respective marker and the marker list are shown in the diagram.

Remote command:

n.a.

**Trace - Power Analysis**

Selects the trace the marker is assigned to.

Remote command:

n.a.

**8.4.4.6 NRP-Z Configure Settings**

The "Configure" dialog allows you to set measurement and sensor parameters.

- [Configure Measurement Settings](#).....250
- [Configure Sensors Settings](#)..... 254
- [Configure Diagram](#)..... 257
- [Configure Time Mode Settings](#).....259
- [Trace Settings](#)..... 259
- [Pulse Data Notifications Settings](#).....261
- [Trigger Settings](#).....266
- [Gate Mode Settings](#)..... 268
- [Next Window List](#)..... 270

**Configure Measurement Settings**

Access:

1. Select "Clk Syn/Power Sens" > "NRP-Z Power Analysis".
2. Select "Configure" > "Configure Measurement".

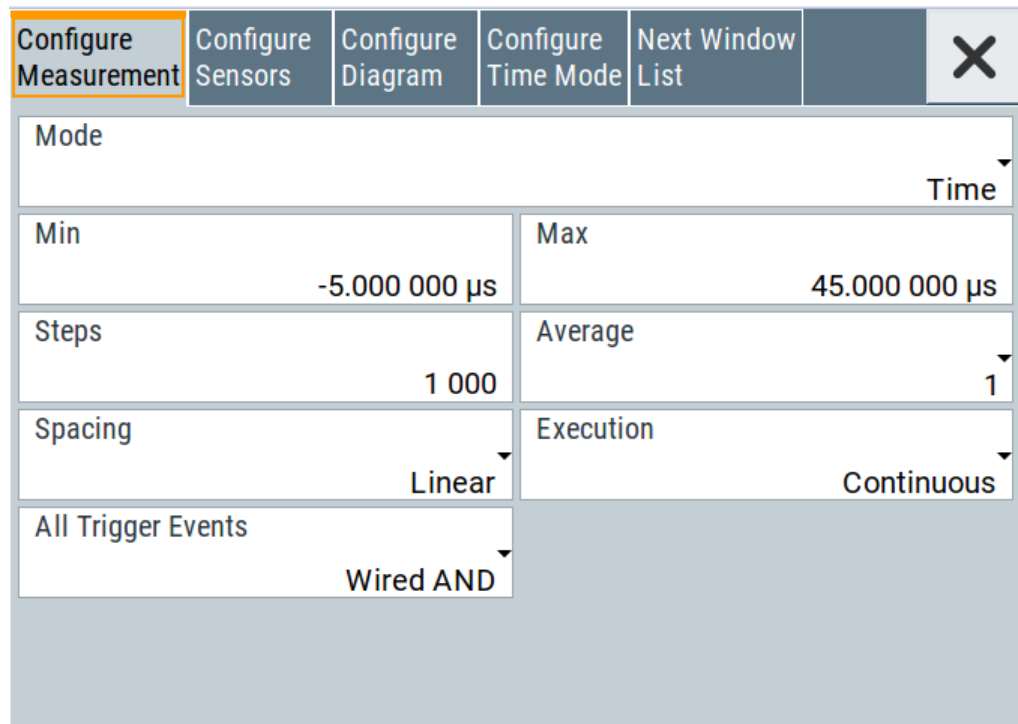

The measurement section provides the parameters for configuring the measurement either in frequency, power or time domain. Depending on the measurement domain, the settings vary.

### Mode - Power Analysis

Selects the measurement mode.

"Frequency"	Power versus frequency measurement (frequency response).
"Power"	Power versus power measurement (power sweep, AM/AM).
"Time"	Power versus time measurement (envelope power measurement as a function of time, NRP trace mode). The R&S SMA100B samples power over a time interval and assigns the internal power values that have been determined to several points. This mode also provides gated measurement and pulse data analysis, e.g. with a connected R&S NRP-Z81, and the corresponding graphical display "Gate View" and "Pulse Data View".

Remote command:

`:SENSe[:POWER]:SWEep:MODE` on page 507

### Min - Power Analysis

Sets the minimum frequency/power/time of the measurement.

The available frequency/power range depends on the frequency/power range of the generator and the used power sensor.

The range for the start time is -1s to +1s. Value 0 defines the trigger point. By choosing a negative time value, the trace can be shifted in the diagram.

It is possible, that the measurement cannot be performed over the complete time range because of limitations due to sensor settings. In this case, the R&S SMA100B generates an error message.

If you change this value for a finished single measurement, only the scaling of the x-axis changes. This way, you can zoom the trace. However, for subsequent measurements, the measurement range is changed according to the new setting.

If you change this value during a continuous measurement, only the scaling of the x-axis changes for measurement cycles that have been triggered before the change. For subsequent measurement cycles, the measurement range changes according to the new setting.

Remote command:

`:SENSe[:POWER]:SWEep:FREQuency:STARt` on page 496

`:SENSe[:POWER]:SWEep:POWer:STARt` on page 509

`:SENSe[:POWER]:SWEep:TIME:STARt` on page 514

### Max - Power Analysis

Sets the maximum frequency/power/time of the measurement.

The available frequency/power range depends on the frequency/power range of the instrument and the used power sensor.

The range for the stop time is 0 s to 2 s. Value 0 defines the trigger point.

It is possible, that the measurement cannot be performed over the complete time range because of limitations due to sensor settings. In this case, an error message is output.

If you change this value for a finished single measurement, only the scaling of the x-axis changes. This way, you can zoom the trace. However, for subsequent measurements the measurement range is changed according to the new setting.

If you change this value during a continuous measurement, only the scaling of the x-axis changes for measurement cycles that have been triggered before the change. For subsequent measurement cycles, the measurement range changes according to the new setting.

Remote command:

`:SENSe[:POWer]:SWEep:FREQuency:STOP` on page 497

`:SENSe[:POWer]:SWEep:POWer:START` on page 509

`:SENSe[:POWer]:SWEep:TIME:STOP` on page 515

### Steps - Power Analysis

Sets the number of steps for the sweep. The number of measured points is steps + 1. The number of steps is one of the parameters that define the measurement speed. The higher the number of steps, the longer the measurement takes (frequency and power mode).

Remote command:

`:SENSe[:POWer]:SWEep:FREQuency:STEPs` on page 497

`:SENSe[:POWer]:SWEep:POWer:STEPs` on page 509

`:SENSe[:POWer]:SWEep:TIME:STEPs` on page 514

### Timing - Power Analysis

Selects the timing mode in frequency or power domain.

This parameter is only available for [Configure Measurement Settings](#) > "Frequency"/"Power".

"Fast" Fast measurement with an integration time of 2 ms for each measurement step.

"Normal" A longer but more precise measurement (integration time is 20 ms/step).

Remote command:

`:SENSe[:POWer]:SWEep:FREQuency:TIMing[:MODE]` on page 497

`:SENSe[:POWer]:SWEep:POWer:TIMing[:MODE]` on page 510

### Average - Power Analysis

Selects the averaging factor in time domain.

The factor determines how many measurement cycles are used to form a measurement result. Higher averaging counts reduce noise but increase the measurement time. Averaging requires a stable trigger event so that the measurement cycles have the same timing. If factor 1 is selected, no averaging is performed.

This parameter is only available for [Configure Measurement Settings](#) > "Time".

Remote command:

`:SENSe[:POWer]:SWEep:TIME:AVERAge[:COUNT]` on page 512

### Spacing - Power Analysis

Sets the mode for calculating the sweep steps.



In power versus frequency mode, selection between linear and logarithmic spacing is possible.

- "Linear"
- Power versus frequency  
In a linear sweep, the frequency is swept in equidistant steps over the continuous frequency range. The x-axis is a linear frequency axis.
  - Power versus power  
The sweeps are performed at constant frequency but with variable generator power that is swept in linear, equidistant steps over a continuous range. The x-axis is a dB-linear power axis.
  - Power versus time  
The sweeps are performed at constant frequency and stimulus power. The measurement is repeated over a specified period of time at constant time intervals.
- "Logarithmic"    Power versus frequency  
In a logarithmic sweep, the frequency is swept in equidistant steps on a logarithmic scale. The x-axis is a logarithmic frequency axis.

Remote command:

[:SENSe\[:POWER\]:SWEep:FREQuency:SPACing\[:MODE\]](#) on page 496

[:SENSe\[:POWER\]:SWEep:POWer:SPACing\[:MODE\]](#) on page 509

[:SENSe\[:POWER\]:SWEep:TIME:SPACing\[:MODE\]](#) on page 514

### Execution - Power Analysis

Selects single or continuous mode in power analysis.

The measurement is started in the diagram using the "Start" button. During measurement, the "Start" button is replaced by a "Stop" button which can be used to abort the measurement. The progress bar indicates the status of the measurement.

"Single"            Selects single measurement.

"Cont."            Selects continuous measurements.

Remote command:

[:SENSe\[:POWER\]:SWEep:RMODE](#) on page 512

[:SENSe\[:POWER\]:SWEep:POWer:RMODE](#) on page 509

[:SENSe\[:POWER\]:SWEep:FREQuency:RMODE](#) on page 496

[:SENSe\[:POWER\]:SWEep:TIME:RMODE](#) on page 514

### All Trigger Events - Power Analysis

Selects the trigger mode for measurements in the time domain.

The measurement data processing starts with a trigger event in one of the sensors (Logical OR), or when all channels are triggered (logical AND). Each sensor evaluates a trigger event according to its setting independently.

This function supports the internal or external trigger modes with multi-channel time measurements.

"Wired AND"      The measurement starts when all channels are triggered.

"Wired OR"        The measurement starts when a trigger event occurs.

Remote command:

[:SENSe\[:POWER\]:SWEep:TIME:TEVents](#) on page 515

## Configure Sensors Settings

Access:

1. Select "Clk Syn/Power Sens" > "NRP-Z Power Analysis".
2. Select "Configure" > "Configure Sensors"

Configure Measurement	Configure Sensors	Configure Diagram	Configure Time Mode	Next Window List		✕
	2 - NRP-Z81		Zero			
Level Offset	On		3.00 dB			
S-Parameter	Unused					
Separate Frequency						
Use Separate Frequ.	<input checked="" type="checkbox"/>					
	1.000 000 MHz					

The "Configure Sensors" dialog provides specific parameters for the power sensor. This part of the dialog can differ from the following description depending on the sensor used. Refer to the manual of the power sensor in this case.

### Power Sensor - Power Analysis

Selects the power sensor to be set if more than one sensor is connected to the instrument.

Remote command:

n.a.

In remote control, the sensor is selected via the numeric suffix in the sense key word of the command, for example `SENSe2:POWer:SWEep:....`

### Zero - Power Analysis

Activates the auto zero function.

Zeroing calibrates the external power sensor by adjusting its reading at zero signal power. For this purpose, the RF power source must be switched off or disconnected from the sensor. If a Rohde & Schwarz power sensor receives an input power during the zeroing process, it aborts zeroing and generates an error message. Zeroing takes a few seconds, depending on the sensor model. Refer to the documentation of your power sensor for more information.

### Tips for zeroing

When to perform zeroing:

- During warm up after switching on or connecting the instrument
- After a substantial change of the ambient temperature
- After fastening the power sensor module to an RF connector at high temperature
- After several hours of operation
- When low-power signals are to be measured, e.g. less than 10 dB above the lower measurement limit.
- Switch off the RF power source for zeroing, but do not disconnect it from the power sensor. This proceeding keeps the thermal equilibrium, and the zeroing process also compensates the noise that superimposes the measured signal (e.g. from a broadband amplifier).

#### Pulse Data

Accesses the dialog for configuring the settings for pulse data analysis.

See "[Trace Settings](#)" on page 259.

#### Trigger..

Accesses the dialog for configuring the trigger settings.

See "[Trigger Settings](#)" on page 266

#### Level Offset State- Power Analysis

Activates a level offset at the sensor input. Set the offset value in the entry field on the right.

Remote command:

`:SENSe<ch>[:POWER]:SWEep:FREQuency[:SENSor]:OFFSet:STATe`

on page 487

`:SENSe<ch>[:POWER]:SWEep:TIME[:SENSor]:OFFSet:STATe` on page 490

`:SENSe<ch>[:POWER]:SWEep:TIME[:SENSor]:OFFSet:STATe` on page 490

#### Level Offset - Power Analysis

Sets the level offset at the sensor input. To consider the value, activate the offset.

Remote command:

`:SENSe<ch>[:POWER]:SWEep:FREQuency[:SENSor]:OFFSet` on page 486

`:SENSe<ch>[:POWER]:SWEep:POWer[:SENSor]:OFFSet` on page 488

`:SENSe<ch>[:POWER]:SWEep:TIME[:SENSor]:OFFSet` on page 490

#### Use S-Parameter - Power Analysis

Activates the use of the S-parameters correction data of the connected power sensor. For sensors with attenuator, this checkbox is automatically checked.

Refer also to the manual of the connected R&S power sensor for a description on how to use the S-parameters table.

#### Use Separate Frequency- Power Analysis

This setting is offered for measurements with DUTs that change the measurement frequency (like modulators), thus changing the input frequency of the sensor.

The parameters vary depending on the measurement modes:

- Power versus frequency measurement

Activates the use of a different frequency range other than the set signal generator frequency range for the measurement. The separate minimum and maximum frequency values are set below.

The x-scale of the diagram can be adjusted to the separate frequency range with functions "Use as X Scale" and "Map to X Scale".

- Power versus power measurement / Power versus time measurement  
Activates the use of a different frequency other than the set signal generator frequency for the measurement. The separate frequency value is set in the entry window below.

Remote command:

`:SENSe<ch>[:POWER]:SWEep:FREQuency[:SENSor]:SRANge[:STATe]`

on page 488

`:SENSe<ch>[:POWER]:SWEep:POWer[:SENSor]:SFRequency:STATe`

on page 489

`:SENSe<ch>[:POWER]:SWEep:POWer[:SENSor]:SFRequency` on page 489

`:SENSe<ch>[:POWER]:SWEep:TIME[:SENSor]:SFRequency:STATe`

on page 492

`:SENSe<ch>[:POWER]:SWEep:TIME[:SENSor]:SFRequency` on page 492

#### Min Frequency - Power Analysis

This parameter is only available for [Configure Measurement Settings](#) > "Frequency" and [Use Separate Frequency- Power Analysis](#) > "Active".

Sets the minimum frequency of the measurement.

Remote command:

`:SENSe<ch>[:POWER]:SWEep:FREQuency[:SENSor]:SRANge:START`

on page 487

#### Max Frequency - Power Analysis

This parameter is only available for [Configure Measurement Settings](#) > "Frequency" and [Use Separate Frequency- Power Analysis](#) > "Active".

Sets the maximum frequency of the measurement.

Remote command:

`:SENSe<ch>[:POWER]:SWEep:FREQuency[:SENSor]:SRANge:STOP`

on page 487

#### Use as X Scale - Power Analysis

This parameter is only available for [Configure Measurement Settings](#) > "Frequency" and [Use Separate Frequency- Power Analysis](#) > "Active".

Activates the use of the separate frequency min and max values for the scaling of the x-axis. Thus, the trace for this sensor is visible in the diagram, especially for frequency ranges that differ substantially from the generator settings.

If more than one sensor is active, which use separate frequencies, the option is only available for one sensor. To indicate the traces of the other sensors, use function "Map to X Scale".

Remote command:

n.a.

**Map to X Scale - Power Analysis**

This parameter is only available for [Configure Measurement Settings](#) > "Frequency" and [Use Separate Frequency- Power Analysis](#) > "Active".

Maps the trace of a sensor that uses separate frequency to the current scaling of the diagram. Usually the scale is determined by the set frequency range of the generator. If more than one sensor is active, which use separate frequencies, the scale can also be determined by the separate frequency range of one of the other sensors.

Remote command:

n.a.

**Configure Diagram**

Access:

1. Select "Clk Syn/Power Sens" > "NRP-Z Power Analysis".
2. Select "Configure" > "Configure Diagram"

Configure Measurement	Configure Sensors	Configure Diagram	Configure Time Mode	Next Window List	
Min Level		-40.00 dBm		Max Level	
				30.00 dBm	
Auto Scale		Expand Only (Coarse)		Reset Auto Scale	
Show Grid		<input checked="" type="checkbox"/>			
Background Color		Black			

The "Configure Diagram" covers the parameters for scaling the y-axis and the appearance of the diagram.

**Min - Max Level - Power Analysis**

Selects the minimum and maximum value of the y-axis.

Remote command:

[:SENSe\[:POWER\]:SWEep:FREQuency:YSCale:MAXimum](#) on page 498

[:SENSe\[:POWER\]:SWEep:FREQuency:YSCale:MINimum](#) on page 499

[:SENSe\[:POWER\]:SWEep:POWer:YSCale:MAXimum](#) on page 511

[:SENSe\[:POWER\]:SWEep:POWer:YSCale:MINimum](#) on page 512

[:SENSe\[:POWER\]:SWEep:TIME:YSCale:MAXimum](#) on page 516

[:SENSe\[:POWER\]:SWEep:TIME:YSCale:MINimum](#) on page 517

**Auto Scale - Power Analysis**

Activates autoscaling of the y-axis of the diagram. The "Auto Scale" function adjusts the scale divisions so that the entire trace fits into the diagram area.

"Off" Auto scale is deactivated. Switching from activated to deactivated, the scaling is maintained.

"Expand Only (Coarse/Fine)"

Auto scale is activated. Automatically selects the appropriate scaling of the y-axis so that the trace is always visible. The range is expanded when a value is out of the right or the left end-of-scale value. The step width is 5 dB for selection "Exp. (Coarse)" and variable in the range of 0.2 dB to 5 dB for selection "Exp. (Fine)".

"Float (Coarse/Fine)"

Auto scale is activated, that means this parameter automatically selects the appropriate scaling of the y-axis so that the trace is always visible. The range is either expanded, when a value is out of the right/left end-of-scale value or it is reduced when the trace fits into a smaller scale area. The step width is 5 dB for selection "Flt. (Coarse)" and variable in the range of 0.2 dB to 5 dB for selection "Flt. (Fine)".

Remote command:

`:SENSe[:POWER]:SWEep:FREQuency:YSCale:AUTO` on page 498

`:SENSe[:POWER]:SWEep:POWer:YSCale:AUTO` on page 510

`:SENSe[:POWER]:SWEep:TIME:YSCale:AUTO` on page 515

**Reset Auto Scale - Power Analysis**

Resets the scaling of the y-axis to suitable values after the use of auto scaling in the expanding mode. For this mode, the Y scale can get too expanded because of temporary high-power values. The reset function resets the diagram again, to indicate smaller power values.

Remote command:

`:SENSe[:POWER]:SWEep:FREQuency:YSCale:AUTO:RESet` on page 498

`:SENSe[:POWER]:SWEep:POWer:YSCale:AUTO:RESet` on page 511

`:SENSe[:POWER]:SWEep:TIME:YSCale:AUTO:RESet` on page 516

**Show Grid - Power Analysis**

Activates the indication of a grid in the diagram area.

Remote command:

`:DISPlay[:WINDow][:POWER]:SWEep:GRID:STATe` on page 484

**Background Color - Power Analysis**

Sets the background color of the diagram to black or white. The background color is also effective for the hardcopy of the diagram.

Remote command:

`:DISPlay[:WINDow][:POWER]:SWEep:BACKground:COLor` on page 483

### Configure Time Mode Settings

The time measurement mode enables you to analyze internally generated or externally supplied signals. In time mode, the measurement requires an additional trigger event, with selectable level, hysteresis and drop time. In time domain, you can also analyze measured pulse data.

### Trace Settings

Access:

1. Select "Clk Syn/Power Sens" > "NRP-Z Power Analysis".
2. Select "Configure" > "Configure Measurement".
3. Set "Mode" > "Time".
4. Select "Configure Time Mode"
5. Select the "Trace" tab.

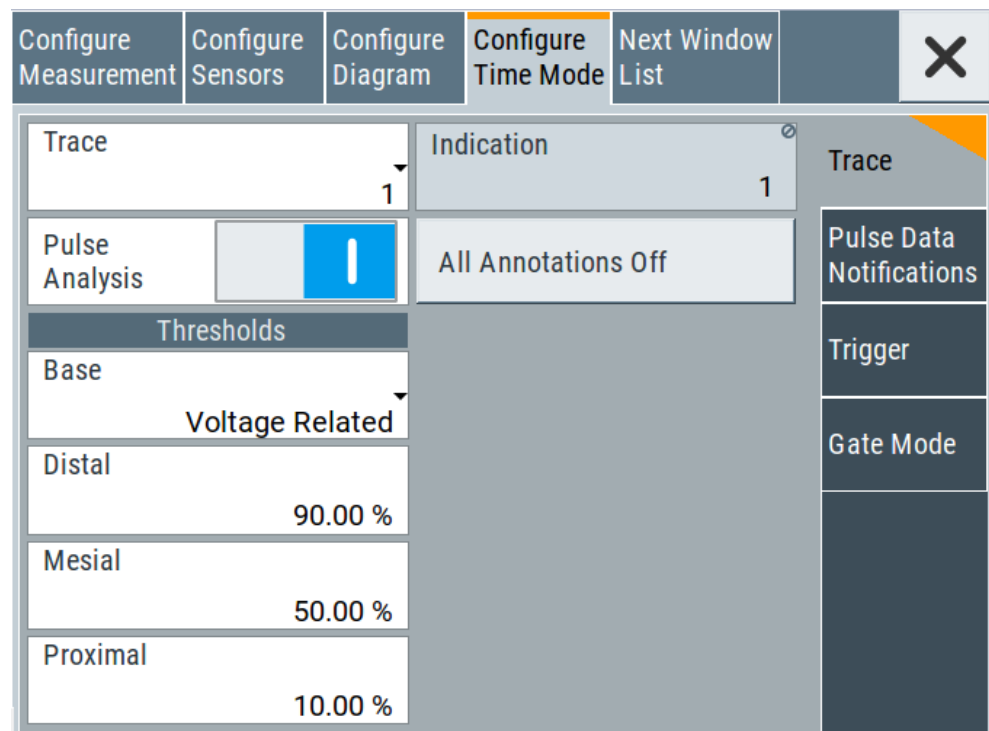

The "Trace" tab contains the parameters for the evaluation of important pulse parameters, provided the used power sensor supports automatic pulse analysis.

### Trace

Selects the trace the sensor is assigned to.

To assign a sensor to a trace, use the trace buttons, see [Off / NRP-Zxx](#).

**Indication**

Indicates the type of power sensor assigned to the selected trace. This field is automatically updated if the sensor is connected or disconnected. Also, this sensor is indicated on the trace button in the measurement diagram.

This parameter is only available for [Configure Measurement Settings](#) > "Time".

Remote command:

n.a.

**Pulse Analysis**

Activates pulse data analysis.

To start the automatic pulse analysis, select "Start Cont." button in the main measurement diagram.

Remote command:

[:SENSe<ch>\[:POWER\]:SWEep:TIME\[:SENSor\]:PULSe:STATe](#) on page 490

**All Annotations Off**

Indicates the state of the annotations.

Remote command:

n.a.

**Base**

Selects the calculation basis for the threshold parameters.

"Voltage related"

Calculates the pulse parameters rise/fall time and pulse width by the voltage over time  $U(t)$ .

Voltage-related parameters represent the usual case.

"Power related"

Represents the pulse parameters as power values.

To obtain equivalent power-dependent values, the voltage-dependent threshold values are converted (squared), (see example in table below).

	Distal	Mesial	Proximal
Voltage related:	90%	50%	10%
Power related:	81%	25%	1 %
log. Scale (for example): (approximately, difference between top- base power > 30 dB )	-0.9dB	-6dB	-20dB

Remote command:

[:SENSe<ch>\[:POWER\]:SWEep:TIME\[:SENSor\]:PULSe:THReshold:BASE](#)

on page 491

[:TRACe<ch>\[:POWER\]:SWEep:PULSe:THReshold:BASE?](#) on page 523



**Distal**

Sets the upper reference level in terms of percentage of the overall pulse level (power or voltage related). The distal power defines the end of the rising edge and the start of the falling edge of the pulse.

Remote command:

```
:SENSe<ch>[:POWer]:SWEep:TIME[:SENSor]:PULSe:THReshold:POWer:HREFerence on page 491
```

```
:TRACe<ch>[:POWer]:SWEep:PULSe:THReshold:POWer:HREFerence on page 524
```

**Medial**

Sets the medial reference level in terms of percentage of the overall pulse level (power or voltage related). This level is used to define the pulse width ( $\tau$ ) and pulse period.

Remote command:

```
:SENSe<ch>[:POWer]:SWEep:TIME[:SENSor]:PULSe:THReshold:POWer:REFerence on page 492
```

```
:TRACe<ch>[:POWer]:SWEep:PULSe:THReshold:POWer:REFerence on page 524
```

**Proximal**

Sets the lower reference level in terms of percentage of the overall pulse level (power or voltage related).

The proximal power defines the start of the rising edge and the end of the falling edge of the pulse.

Remote command:

```
:SENSe<ch>[:POWer]:SWEep:TIME[:SENSor]:PULSe:THReshold:POWer:LREFerence on page 491
```

```
:TRACe<ch>[:POWer]:SWEep:PULSe:THReshold:POWer:LREFerence on page 524
```

**Pulse Data Notifications Settings**

Access:

1. Select "Clk Syn/Power Sens" > "NRP-Z Power Analysis".
2. Select "Configure" > "Configure Measurement".
3. Set "Mode" > "Time".
4. Select "Configure Time Mode"

5. Select the "Pulse Data notifications" tab.

Configure Measurement	Configure Sensors	Configure Diagram	Configure Time Mode	Next Window List	
Duty Cycle	<input type="checkbox"/>		Rise Time	<input checked="" type="checkbox"/>	Trace
Pulse Width	<input checked="" type="checkbox"/>		Pulse Start Time	<input type="checkbox"/>	<b>Pulse Data Notifications</b>
Pulse Period	<input checked="" type="checkbox"/>		Overshoot (Rising Edge)	<input type="checkbox"/>	Trigger
Pulse Off Time	<input checked="" type="checkbox"/>		Fall Time	<input checked="" type="checkbox"/>	Gate Mode
			Pulse Stop Time	<input type="checkbox"/>	
			Overshoot (Falling Edge)	<input type="checkbox"/>	
Signal Power		Pulse Power			
Peak Power	<input checked="" type="checkbox"/>		Top Power	<input type="checkbox"/>	
Average Power	<input type="checkbox"/>		Base Power	<input checked="" type="checkbox"/>	
Minimal Power	<input type="checkbox"/>		Distal Power	<input checked="" type="checkbox"/>	
			Mesial Power	<input checked="" type="checkbox"/>	
			Proximal Power	<input type="checkbox"/>	

In the "Pulse Data Notification" tab, you can determine the parameter values to be indicated on bottom of the diagram.

#### Notifications - Pulse Data Analysis

Selects the pulse parameters to be indicated below the measurement diagram.

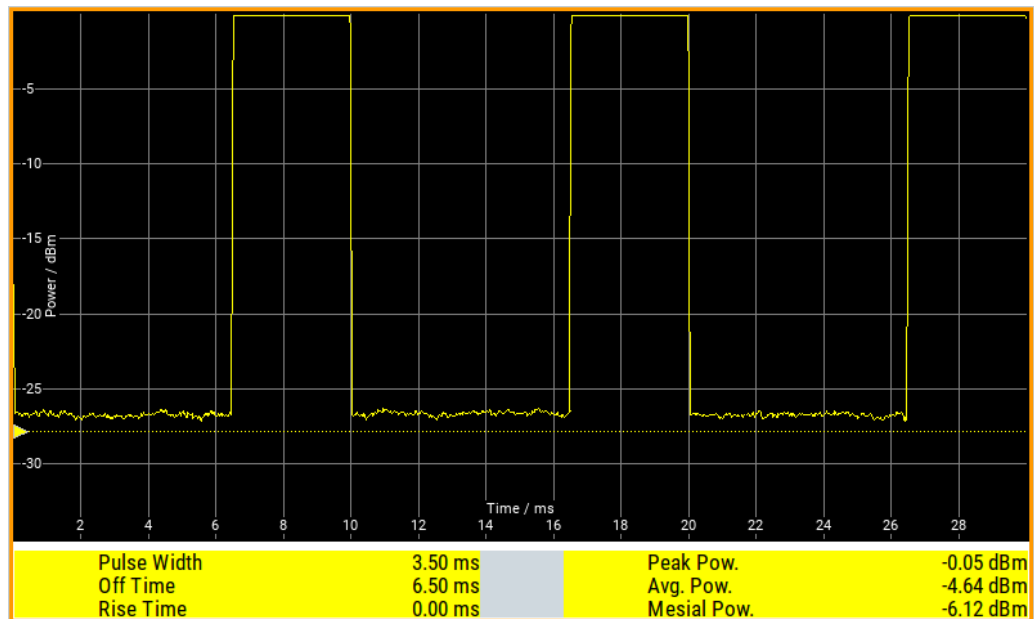

#### Duty Cycle ← Notifications - Pulse Data Analysis

Indicates the ratio between the pulse duration ( $\tau$ ) and the pulse period ( $T$ ) of the measured pulse signal in per cent:

$$\text{Duty Cycle} = (\text{pulse duration} / \text{pulse period}) * 100$$

Remote command:

```
:TRACe<ch>[:POWer]:SWEep:MEASurement:PULSe:DCYCLe? on page 521
:TRACe<ch>[:POWer]:SWEep:MEASurement:PULSe:DCYCLe:DISPlay:
ANNotation[:STATe] on page 522
```

#### Pulse Width ← Notifications - Pulse Data Analysis

Indicates the pulse duration of the pulse data measurement in seconds.

Remote command:

```
:TRACe<ch>[:POWer]:SWEep:MEASurement:PULSe:DURation? on page 521
:TRACe<ch>[:POWer]:SWEep:MEASurement:PULSe:DURation:DISPlay:
ANNotation[:STATe] on page 522
```

#### Pulse Period ← Notifications - Pulse Data Analysis

Indicates the time the pulse signal needs to complete one cycle.

Remote command:

```
:TRACe<ch>[:POWer]:SWEep:MEASurement:PULSe:PERiod? on page 521
:TRACe<ch>[:POWer]:SWEep:MEASurement:PULSe:PERiod:DISPlay:
ANNotation[:STATe] on page 522
```

#### Pulse Off Time ← Notifications - Pulse Data Analysis

Determines the time the pulse signal is low, that means as long as the signal level is below the proximal value.

Remote command:

`:TRACe<ch>[:POWer]:SWEep:MEASurement:PULSe:SEPARation?` on page 521

`:TRACe<ch>[:POWer]:SWEep:MEASurement:PULSe:PERiod:DISPlay:`

`ANNotation[:STATe]` on page 522

### Transition Times - Pulse Data Analysis

Selects the transition parameters of the pulse signal to be indicated below the measurement diagram.

The R&S NRP-Z sensor searches for the first rising edge and the first falling edge in the trace.

### Rise Time / Fall Time ← Transition Times - Pulse Data Analysis

Displays the time the signal requires from crossing low reference until it reaches high reference level and vice versa.

Remote command:

`:TRACe<ch>[:POWer]:SWEep:MEASurement:TRANSition:NEGative:DURation?` on page 521

`:TRACe<ch>[:POWer]:SWEep:MEASurement:TRANSition:NEGative:DURation:DISPlay:ANNotation[:STATe]` on page 522

`:TRACe<ch>[:POWer]:SWEep:MEASurement:TRANSition:POSitive:DURation?` on page 521

`:TRACe<ch>[:POWer]:SWEep:MEASurement:TRANSition:POSitive:DURation:DISPlay:ANNotation[:STATe]` on page 522

### Pulse Start Time / Pulse Stop Time ← Transition Times - Pulse Data Analysis

Displays the time when the pulse signal crosses the medial reference level.

Remote command:

`:TRACe<ch>[:POWer]:SWEep:MEASurement:TRANSition:NEGative:OCCurrence?` on page 521

`:TRACe<ch>[:POWer]:SWEep:MEASurement:TRANSition:NEGative:OCCurrence:DISPlay:ANNotation[:STATe]` on page 522

`:TRACe<ch>[:POWer]:SWEep:MEASurement:TRANSition:POSitive:OCCurrence?` on page 521

`:TRACe<ch>[:POWer]:SWEep:MEASurement:TRANSition:POSitive:OCCurrence:DISPlay:ANNotation[:STATe]` on page 523

### Overshoot (Rising Edge / Falling Edge) ← Transition Times - Pulse Data Analysis

Display the maximum value of the pulse signal following a rising transition and the minimum value of the signal after a falling transition, respectively.

Overshoot values are given in per cent of the pulse amplitude as shown below:

- $\text{Overshoot}(\text{pos}) = 100 \cdot (\text{maximum} - \text{top level}) / (\text{top level} - \text{base level})$
- $\text{Overshoot}(\text{neg}) = 100 \cdot (\text{base level} - \text{minimum}) / (\text{top level} - \text{base level})$

Remote command:

`:TRACe<ch>[:POWer]:SWEep:MEASurement:TRANSition:POSitive:OVERshoot?` on page 521

`:TRACe<ch>[:POWer]:SWEep:MEASurement:TRANSition:POSitive:OVERshoot:DISPlay:ANNotation[:STATe]` on page 523

`:TRACe<ch>[:POWer]:SWEep:MEASurement:TRANSition:NEGative:OVERshoot?` on page 521

`:TRACe<ch>[:POWer]:SWEep:MEASurement:TRANSition:NEGative:OVERshoot:DISPlay:ANNOtation[:STATe]` on page 522

### Signal Power - Pulse Data Analysis

Selects the power parameters of the pulse signal to be indicated below the measurement diagram.

#### Minimal / Peak / Average Power ← Signal Power - Pulse Data Analysis

Display the minimum, the maximum and the average power of the pulse signal in dBm.

Remote command:

`:TRACe<ch>[:POWer]:SWEep:MEASurement:POWer:MINimum?` on page 521

`:TRACe<ch>[:POWer]:SWEep:MEASurement:POWer:MINimum:DISPlay:ANNOtation[:STATe]` on page 522

`:TRACe<ch>[:POWer]:SWEep:MEASurement:POWer:MAXimum?` on page 521

`:TRACe<ch>[:POWer]:SWEep:MEASurement:POWer:MAXimum:DISPlay:ANNOtation[:STATe]` on page 522

`:TRACe<ch>[:POWer]:SWEep:MEASurement:POWer:AVErage?` on page 521

`:TRACe<ch>[:POWer]:SWEep:MEASurement:POWer:AVErage:DISPlay:ANNOtation[:STATe]` on page 522

### Pulse Power - Pulse Data Analysis

Selects which pulse power parameters are indicated in the diagram (pulse data view only).

#### Top / Base Power ← Pulse Power - Pulse Data Analysis

Indicate the pulse top and base level of the analyzed signal in dBm.

Remote command:

`:TRACe<ch>[:POWer]:SWEep:MEASurement:POWer:PULSe:BASE?` on page 521

`:TRACe<ch>[:POWer]:SWEep:MEASurement:POWer:PULSe:BASE:DISPlay:ANNOtation[:STATe]` on page 522

`:TRACe<ch>[:POWer]:SWEep:MEASurement:POWer:PULSe:TOP?` on page 521

`:TRACe<ch>[:POWer]:SWEep:MEASurement:POWer:PULSe:TOP:DISPlay:ANNOtation[:STATe]` on page 522

#### Distal / Mesial / Proximal Power ← Pulse Power - Pulse Data Analysis

Display the absolute power values of the medial, low and high reference level in dBm.

Remote command:

`:TRACe<ch>[:POWer]:SWEep:MEASurement:POWer:LREFerence?` on page 521

`:TRACe<ch>[:POWer]:SWEep:MEASurement:POWer:LREFerence:DISPlay:ANNOtation[:STATe]` on page 522

`:TRACe<ch>[:POWer]:SWEep:MEASurement:POWer:HREFerence?` on page 521

`:TRACe<ch>[:POWer]:SWEep:MEASurement:POWer:HREFerence:DISPlay:ANNOtation[:STATe]` on page 522

[:TRACe<ch>\[:POWer\]:SWEep:MEASurement:POWer:REfERENCE?](#) on page 521  
[:TRACe<ch>\[:POWer\]:SWEep:MEASurement:POWer:REfERENCE:DISPlay:ANNOtation\[:STATe\]](#) on page 522

### Trigger Settings

Access:

1. Select "Clk Syn/Power Sens" > "NRP-Z Power Analysis".
2. Select "Configure" > "Configure Measurement".
3. Set "Mode" > "Time".
4. Select "Configure Time Mode"
5. Select the "Trigger" tab.

Configure Measurement	Configure Sensors	Configure Diagram	Configure Time Mode	Next Window List	X
Sensor		2 - NRP-Z81		Trace	
Mode		Auto		Level	Pulse Data Notifications
Slope		Positive		1.000 dBm	Trigger
Drop Out Time		200 ns		Hysteresis	Gate Mode
		Auto Set		0.500 dB	

#### Sensor - Power Analysis

Selects the power sensor to be set if more than one sensor is connected to the instrument.

Remote command:

n.a.

In remote control the sensor is selected via the numeric suffix in the sense key word of the command, for example `SENSe2:POWer:SWEep:...`

#### Mode - Power Analysis

Selects if the measurement is free running, or starts only after an internal or external trigger event.

Remote command:

[:SENSe<ch>\[:POWer\]:SWEep:TIME\[:SENSor\]:TRIGger:SOURce](#) on page 494

**Level - Power Analysis**

Sets the trigger threshold. This setting is also possible by the trigger marker on the left side of the diagram.

Remote command:

`:SENSe<ch>[:POWER]:SWEep:TIME[:SENSor]:TRIGger:LEVel` on page 494

**Slope - Power Analysis**

Sets the polarity of the active slope of the trigger signals.

"Positive"      The rising edge of a trigger signal is active.

"Negative"      The falling edge of a trigger signal is active.

Remote command:

`:SENSe<ch>[:POWER]:SWEep:TIME[:SENSor]:TRIGger:SLOPe` on page 494

**Hysteresis - Power Analysis**

Sets the hysteresis of the internal trigger threshold. Hysteresis is the magnitude (in dB) the trigger signal level must drop below the trigger threshold (positive trigger slope) before triggering can occur again.

Remote command:

`:SENSe<ch>[:POWER]:SWEep:TIME[:SENSor]:TRIGger:HYSTeresis`  
on page 493

**Drop out Time - Power Analysis**

Determines the minimum time for which the signal must be below (above) the power level defined by [Level - Power Analysis](#) and [Hysteresis - Power Analysis](#) before triggering can occur again. This prevents the trigger system from being activated too early if the trigger threshold is briefly underranged or exceeded.

The dropout time parameter is useful when dealing with, for example, GSM signals with several active slots. When performing a measurement in sync with the signal, a trigger event is to be produced at A, but not at B or C. As the RF power between the slots is below the threshold defined by [Level - Power Analysis](#) and [Hysteresis - Power Analysis](#), the trigger hysteresis alone cannot prevent triggering at B or at C. This is why the dropout time parameter is selected to be greater than the time elapsed between points E and B and between F and C, but less than the time elapsed between G and A. This ensures that triggering takes place at A.

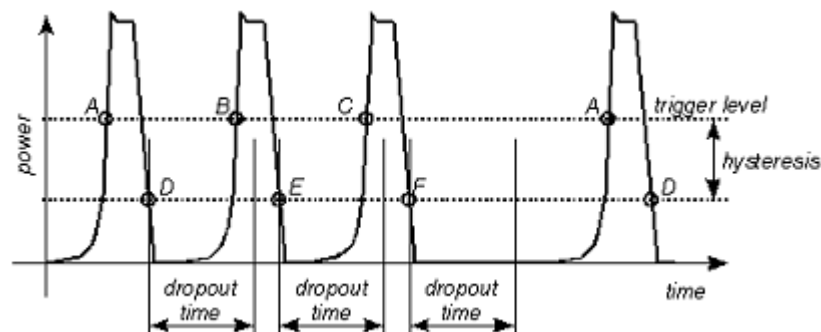

As the mechanism associated with the dropout time parameter is reactivated whenever the trigger threshold is crossed, unambiguous triggering can also be obtained for many complex signals. By contrast, all triggering is suppressed during the hold-off time. For the example described, this would mean that although stable triggering conditions could be obtained with a suitable hold-off time (regular triggering at the same point), it would not be possible to set exclusive triggering at A.

Remote command:

`:SENSe<ch>[:POWer]:SWEep:TIME[:SENSor]:TRIGger:DTIME` on page 493

#### Auto Set - Power Analysis

Sets the trigger level, the hysteresis and the drop out time to default values.

Remote command:

`:SENSe<ch>[:POWer]:SWEep:TIME[:SENSor]:TRIGger:AUTO` on page 493

#### Gate Mode Settings



For "Time" measurement mode only.

Access:

1. Select "Clk Syn/Power Sens" > "NRP-Z Power Analysis".
2. Select "Configure" > "Configure Measurement".
3. Set "Mode" > "Time".
4. Select "Configure Time Mode"



5. Select the "Gate Mode" tab.

Configure Measurement	Configure Diagram	Configure Gate Mode	Configure Sensors	NEXT WINDOW List		✕
Trace		2	Indication	2 - NRP-Z81		
State ● On						
Gate 1						
Start			Stop			
5.000 000 μs			15.000 000 μs			
Gate 2						
Start			Stop			
25.000 000 μs			35.000 000 μs			

The "Gate Mode" tab contains the parameters for defining the time gates for the measurement.

Almost all R&S NRP sensors also support time gated measurements of peak and average power (see the data sheet or operating manual of the respective sensor). Two user-configurable gates can be assigned to one of the traces. Both gates are active at the same time. The values are calculated from the trace data, the time resolution is determined by the resolution of the sensor. An external trigger signal or signal triggering is required for synchronization.

The start and stop time of the gates are indicated as gate markers, a bar between the start and stop marker shows the gate length. The indication state of the gate borders and measurement values is only available for certain diagram views which are switched with the "Next Window List" key. The "Next Window List" dialog provides a selection of views, between which is toggled (see "[Next Window List](#)" on page 270 ).

#### Trace - Gate

Selects the trace of the sensor assigned for the gate measurement. Both gates are assigned to the same trace.

To assign the sensor to a trace, use the trace buttons, see [Off / NRP-Zxx](#).

Remote command:

:CALCulate[:POWER]:SWEep:TIME:GATE<ch>:FEED on page 481

#### Indication

Indicates the type of power sensor assigned to the selected trace. This field is automatically updated if the sensor is connected or disconnected. Also, this sensor is indicated on the trace button in the measurement diagram.

This parameter is only available for [Configure Measurement Settings](#) > "Time".

Remote command:

n.a.

### State - Gate

Enables time gated measurement. The measurement is started with the "Start" button in the main measurement diagram. Both gates are active at one time.

The gate borders and the measurement values (average and peak power) are indicated in/below the measurement diagram. The indication is only available for certain diagram views which are switched with the "Rearrange" key.

Remote command:

[:CALCulate\[:POWer\]:SWEep:TIME:GATE<ch>:STATE](#) on page 482

[:CALCulate\[:POWer\]:SWEep:TIME:GATE<ch>:AVERAge?](#) on page 481

[:CALCulate\[:POWer\]:SWEep:TIME:GATE<ch>:MAXimum?](#) on page 481

[:TRACe\[:POWer\]:SWEep:MEASurement:GATE:DISPlay:ANNOtation\[:STATE\]](#) on page 526

### Start / Stop - Gate

Sets the start and the stop times for the respective gate.

Remote command:

[:CALCulate\[:POWer\]:SWEep:TIME:GATE<ch>:START](#) on page 482

[:CALCulate\[:POWer\]:SWEep:TIME:GATE<ch>:STOP](#) on page 482

### Next Window List

Access:

1. Select "Clk Syn/Power Sens" > "NRP-Z Power Analysis".
2. Select "Configure" > "Next Window List"

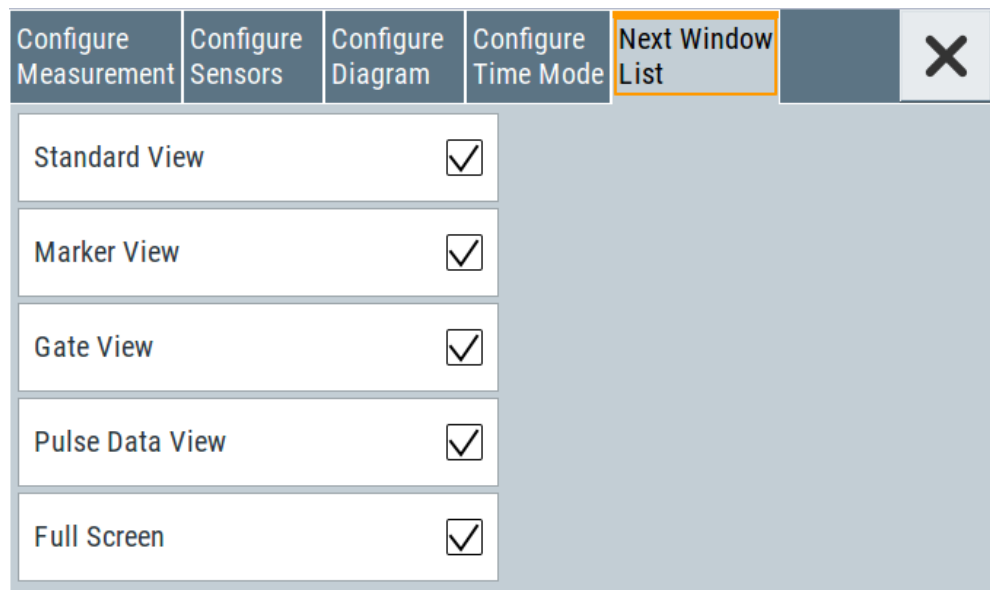

The "Next Window List" dialog provides functions to activate only the required "Views" on the checkboxes to the right.

### Standard View

Shows the graph and the button bar at the left for frequency power and level sweep measurement.

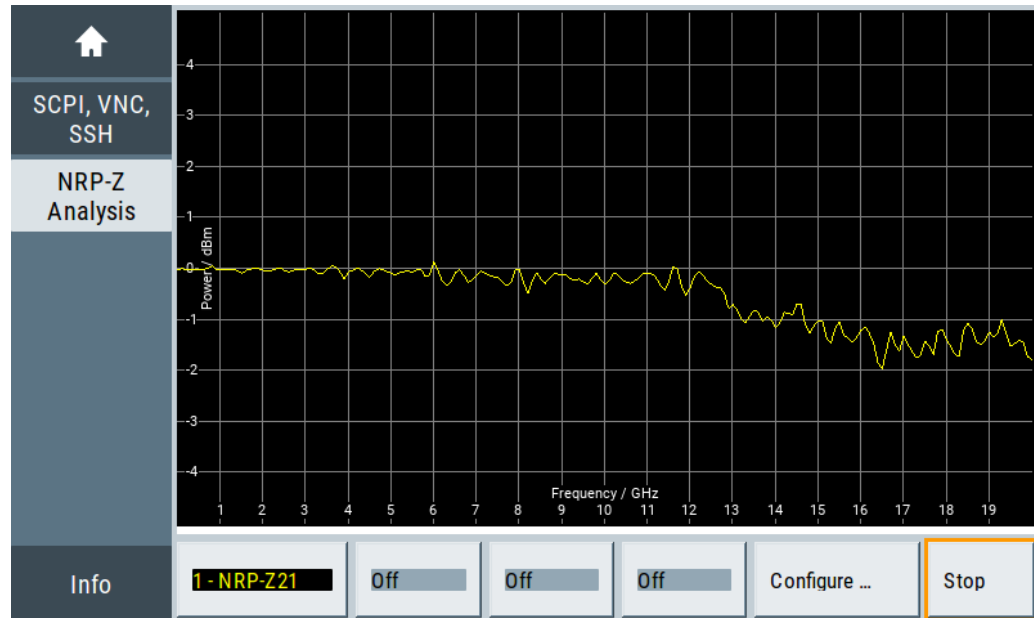

Remote command:

`:TRACe[:POWER]:SWEep:MEASurement:STANDARD:DISPlay:ANNOtation[:STATE]` on page 527

### Marker View

Shows the graph and the corresponding marker values at the bottom for frequency power and level sweep measurement.

Up to four markers can be used to display the current power according to the position of the marker. The value(s) are displayed at the bottom of the window below the graph.

To move the marker lines you can select them and drag them with your finger. Alternatively you can move them with the rotary knob.

For details on configuring the markers, see "[Markers Settings](#)" on page 249.

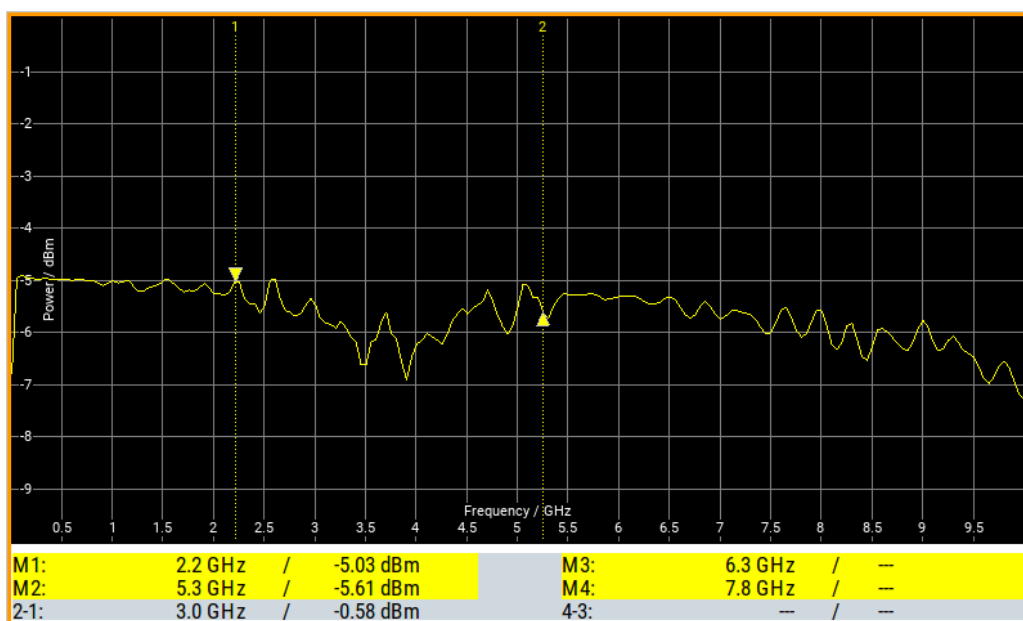

Remote command:

`:TRACe[:POWER]:SWEep:MEASurement:MARKer:DISPlay:ANNotation[:STATe]` on page 526

### Gate View

Shows the graph with the corresponding gate data for time trace and pulse data measurements.

Remote command:

`:TRACe[:POWER]:SWEep:MEASurement:GATE:DISPlay:ANNotation[:STATe]` on page 526

### Pulse Data View

Shows the graph and the corresponding pulse data for time trace and pulse data measurements.

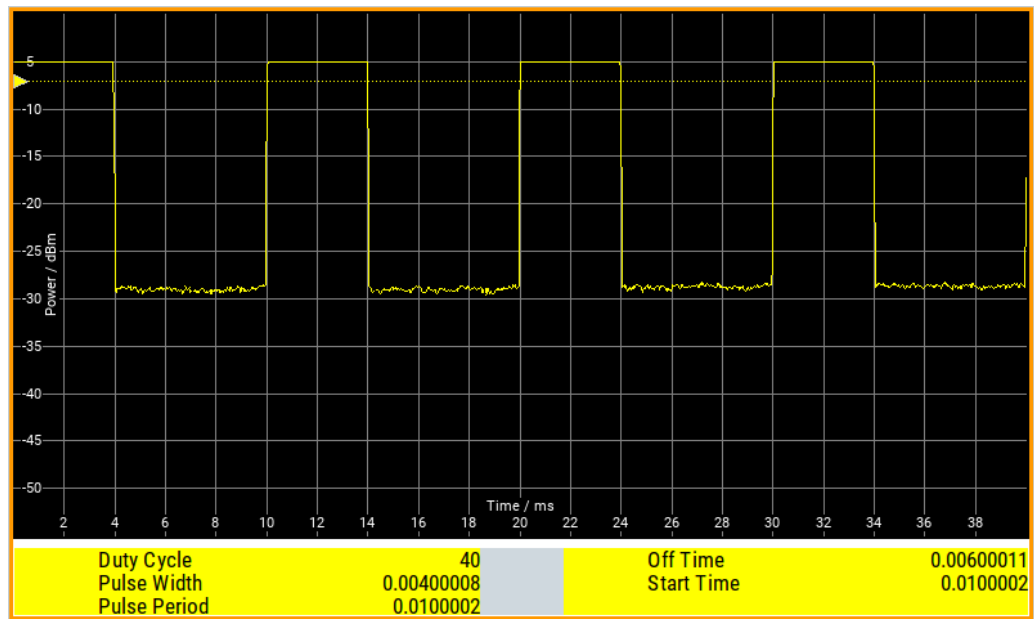

Remote command:

```
:TRACe[:POWER]:SWEep:MEASurement:PULSe:DISPlay:ANNotation[:
STATe] on page 526
```

### Full Screen

Shows the graph in fullscreen, and fades out buttons and list values for frequency power and level sweep measurement.

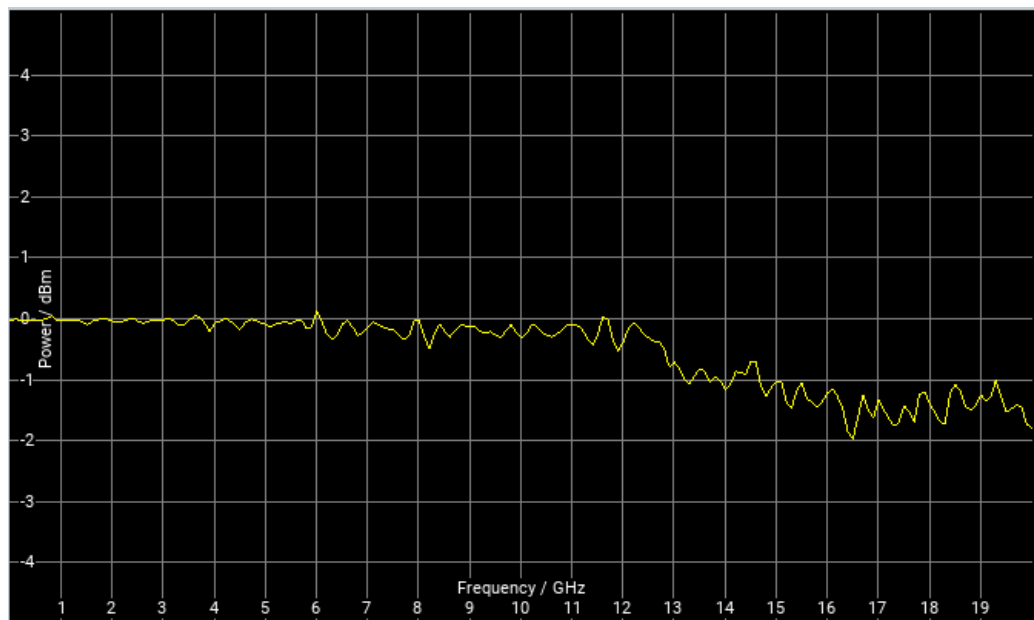

Remote command:

```
:TRACe[:POWER]:SWEep:MEASurement:FULLscreen:DISPlay:ANNotation[:
STATe] on page 525
```

#### 8.4.4.7 Creating Screenshots of Power Analysis Settings

The power analysis save function enables you to save current settings in a file. To document the most important settings for a performed signal generation, you can also save a hardcopy of the current display.

##### Save (Power Analysis) Settings

In the "Save ..." dialog you can find the settings to store a screenshot of the current measurement diagram. The current screen shot is stored as indicated, that means with or without marker indication.

##### Main Settings

Access:

1. Select "Clk Syn/Power Sens" > "NRP Power Analysis".
2. In the diagram window, open the context-sensitive menu.
3. In the menu, select "Save... (Power Analysis)".

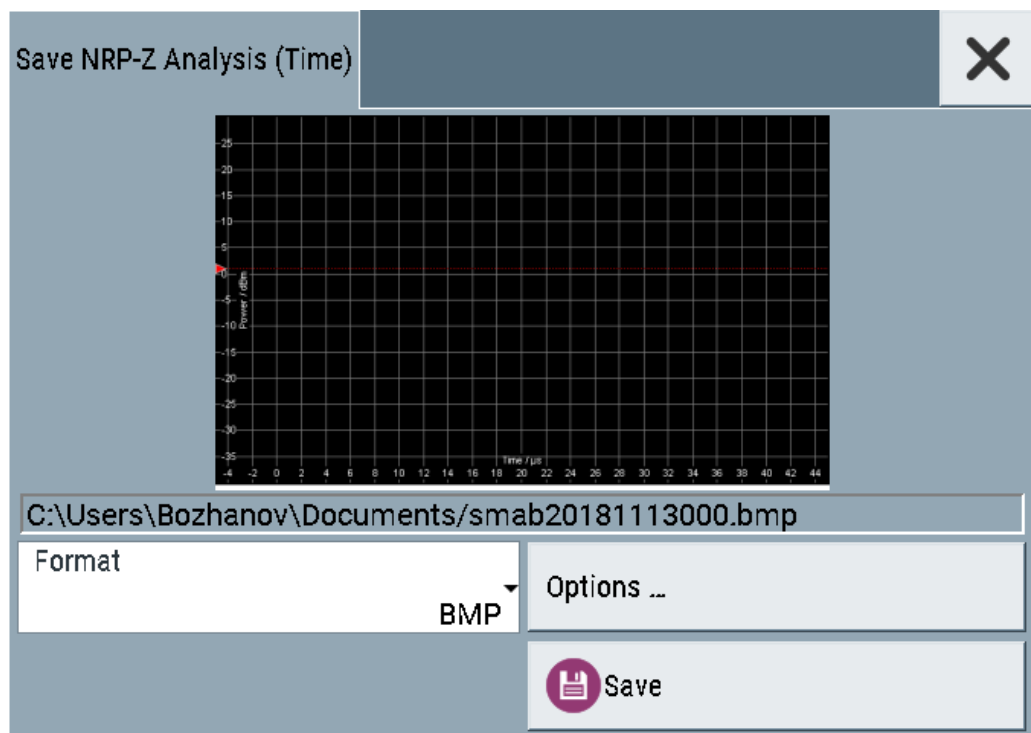

##### File name - Power Analysis

Indicates the file name and directory.

Remote command:

:SENSe[:POWER]:SWEep:HCOPY[:EXECute] on page 507

:SENSe[:POWER]:SWEep:HCOPY:FILE[:NAME] on page 503

`:SENSe[:POWER]:SWEep:HCOpy:FILE[:NAME]:AUTO:STATe` on page 504

`:SENSe[:POWER]:SWEep:HCOpy:FILE[:NAME]:AUTO:FILE?` on page 504

### Format - Power Analysis

Selects the file format.

Several bitmap graphic formats are offered. In addition, format `*.csv` is available which stores the measurement values as ASCII data.

You can refine the csv settings further, see "[CSV Options](#)" on page 277.

Remote command:

`:SENSe[:POWER]:SWEep:HCOpy:DEVIce:LANGuage` on page 501

### Options

Opens a dialog to select the screenshot format and also to activate and select the automatic naming settings.

### Common Settings

Access:

1. Select "Clk Syn/Power Sens" > "NRP Power Analysis".
2. In the diagram window, open the context-sensitive menu.
3. In the menu, select "Save... (Power Analysis)".
4. Select "Options".

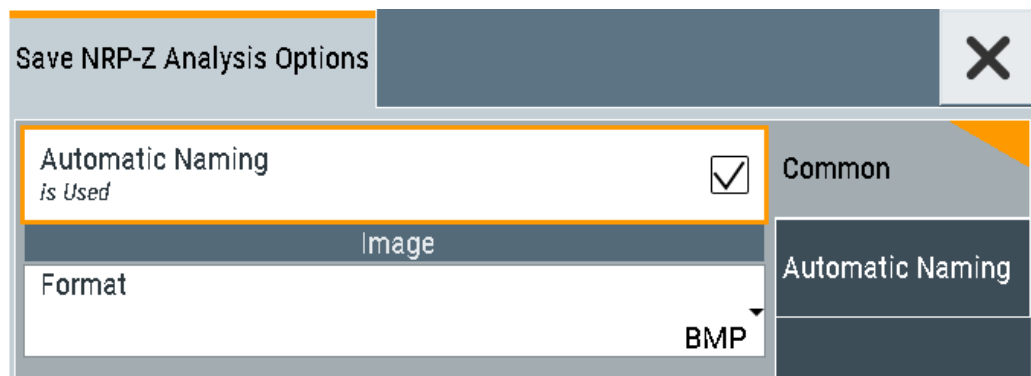

### Automatic Naming

If enabled, the file names are created by selected rules. The filename includes at least one number and optionally additional information.

Remote command:

`:SENSe[:POWER]:SWEep:HCOpy:FILE[:NAME]:AUTO:STATe` on page 504

### Format - Power Analysis

Selects the file format.

Several bitmap graphic formats are offered. In addition, format `*.csv` is available which stores the measurement values as ASCII data.

You can refine the csv settings further, see ["CSV Options"](#) on page 277.

Remote command:

[:SENSe\[:POWER\]:SWEep:HCOPY:DEVIce:LANGUage](#) on page 501

### Automatic Naming Settings

Access:

1. Select "Clk Syn/Power Sens" > "NRP Power Analysis".
2. In the diagram window, open the context-sensitive menu.
3. In the menu, select "Save... (Power Analysis)".
4. Select "Options".
5. In the "Save NRP-Z Analysis Options" dialog, enable "Automatic Naming."

The screenshot shows the "Save NRP-Z Analysis Options" dialog box. The "Path" field is highlighted with an orange border and contains the text "C:\Users\Bozhanov\Documents". To the right of the path field is a "Common" button. Below the path field are two buttons: "Delete All Image Files In Path" and "Clear Path". The "Automatic Naming" section is active, indicated by an orange triangle. It contains three rows of checkboxes: "Prefix" (checked) with a text field containing "smab", "Year" (checked), "Month" (checked), and "Day" (checked). Below these is a "Current Auto Number" field containing "000". At the bottom, the "Resulting File Name" field displays "smab20181113000.bmp".

#### Path

Sets the directory for saving the files.

Remote command:

[:SENSe\[:POWER\]:SWEep:HCOPY:FILE\[:NAME\]:AUTO:DIRectory](#) on page 503

#### Clear Parth

Deletes all image files with extensions "bmp", "img", "png", "xpm" and "csv" in the directory set for automatic naming.



Remote command:

`:SENSe[:POWer]:SWEep:HCOPY:FILE[:NAME]:AUTO:DIRectory:CLEar`  
on page 503

### Prefix, Year, Month, Day, Instrument Name

A selection of the prefix, year, month, day and instrument name are included in the file name.

Remote command:

`:SENSe[:POWer]:SWEep:HCOPY:FILE[:NAME]:AUTO[:FILE]:PREFix:STATe`  
on page 506

`:SENSe[:POWer]:SWEep:HCOPY:FILE[:NAME]:AUTO[:FILE]:PREFix`  
on page 506

`:SENSe[:POWer]:SWEep:HCOPY:FILE[:NAME]:AUTO[:FILE]:DAY:STATe`  
on page 505

`:SENSe[:POWer]:SWEep:HCOPY:FILE[:NAME]:AUTO[:FILE]:DAY?`  
on page 504

`:SENSe[:POWer]:SWEep:HCOPY:FILE[:NAME]:AUTO[:FILE]:MONTH:STATe`  
on page 505

`:SENSe[:POWer]:SWEep:HCOPY:FILE[:NAME]:AUTO[:FILE]:MONTH?`  
on page 505

`:SENSe[:POWer]:SWEep:HCOPY:FILE[:NAME]:AUTO[:FILE]:YEAR:STATe`  
on page 507

`:SENSe[:POWer]:SWEep:HCOPY:FILE[:NAME]:AUTO[:FILE]:YEAR?`  
on page 506

### Current Auto Number

Indicates the number which is used in the automatically generated file name.

Remote command:

`:SENSe[:POWer]:SWEep:HCOPY:FILE[:NAME]:AUTO[:FILE]:NUMBer?`  
on page 506

### Resulting File Name

Indicates the automatically generated file name.

Remote command:

`:SENSe[:POWer]:SWEep:HCOPY:FILE[:NAME]:AUTO:FILE?` on page 504

### CSV Options

Access:

1. Select "Clk Syn/Power Sens" > "NRP Power Analysis".
2. In the diagram window, open the context-sensitive menu.
3. In the menu, select "Save... (Power Analysis)".
4. Set "Format" > "CSV".
5. Select "Options".

6. Select the "CSV Options" tab.

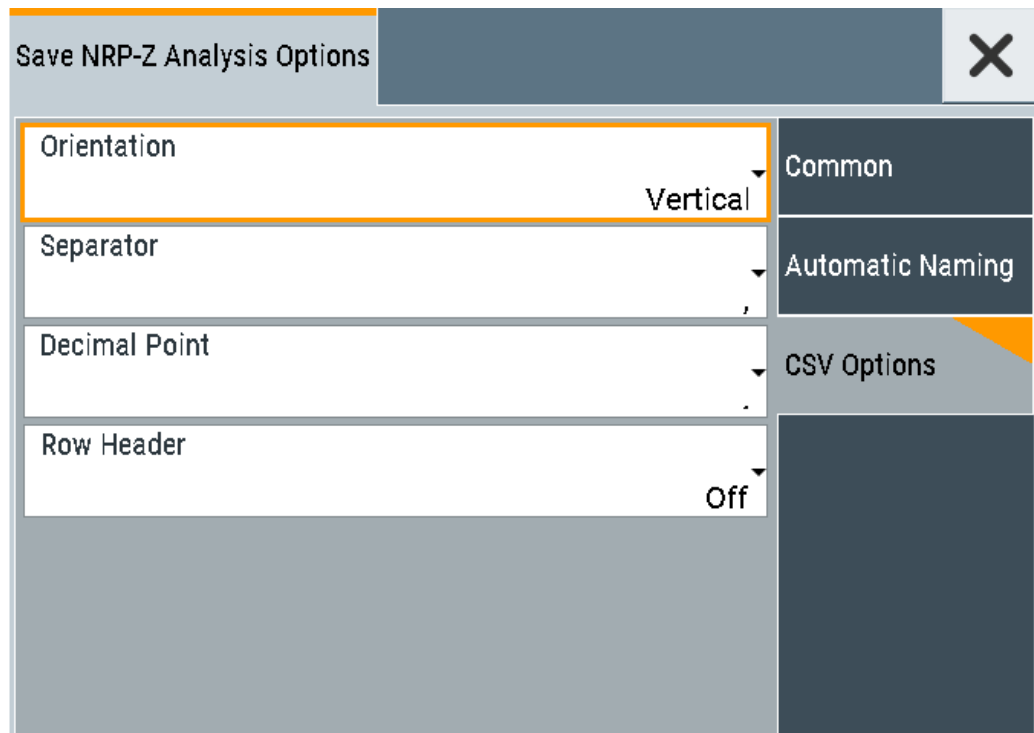

If file format `*.csv` is selected, the trace data is saved as an ASCII file with separated values. CSV files can be imported into the program MS Excel and then processed further. Adjust the value separator and the decimal point according to the language version, to import the data correctly.

### Orientation

Defines the orientation of the X/Y value pairs:

- **Horizontal:**
  - X/Y values of trace 1 in rows 1 and 2,
  - X/Y values of trace 2 in rows 3 and 4,
  - X/Y values of trace 3 in rows 5 and 6,
  - X/Y values of trace 4 in rows 7 and 8.

### Example:

```
Trace1,X[Hz]: 10000.0; 10010.0; 10020.0; 10030.0; ...
Trace1,Y[dBm]: -20.09; -19.17; -18.19; -15.43; ...
Trace2,X[Hz]: 10000.0; 10010.0; 10020.0; 10030.0; ...
Trace2,Y[dBm]: -19.09; -18.17; -17.19; -14.43; ...
Trace3,X[Hz]: 10000.0; 10010.0; 10020.0; 10030.0; ...
Trace3,Y[dBm]: -21.09; -20.17; -19.19; -16.43; ...
Trace4,X[Hz]: 10000.0; 10010.0; 10020.0; 10030.0; ...
Trace4,Y[dBm]: -22.07; -20.14; -21.56; -17.67; ...
```

- **Vertical:**  
X/Y values of trace 1 in column 1 and 2,  
X/Y values of trace 2 in column 3 and 4,  
X/Y values of trace 3 in column 5 and 6,  
X/Y values of trace 4 in column 7 and 8.

**Example:**

```
Trace1,X[Hz]; Trace1,Y[dBm]; Trace2,X[Hz]; Trace2,Y[dBm]; Trace3,X[Hz];
Trace3,Y[dBm]; Trace4,X[Hz]; Trace4,Y[dBm];
10000.0;-20.09;10000.0; -19.09;10000.0;21.09;10000.0;22.07;
10010.0;-19.17;10010.0;-18.17;10010.0; -20.17;10010.0; -20.14;
10020.0;-18.19;10020.0;-17.19;10020.0;-19.19;10020.0;-21.56;
10030.0; -15.43;10030.0; -14.43;10030.0;-16.43;10030.0;-17.67;...
```

Remote command:

```
:SENSe[:POWER]:SWEep:HCOPY:DEvice:LANGuage:CSV:ORientation
on page 502
```

**Separator**

Defines the character to be used to separate the values: tabulator, semicolon, comma or blank.

Remote command:

```
:SENSe[:POWER]:SWEep:HCOPY:DEvice:LANGuage:CSV[:COLumn]:
SEParator on page 502
```

**Decimal Point**

Defines the character to be used as the decimal point of the values: dot or comma.

Remote command:

```
:SENSe[:POWER]:SWEep:HCOPY:DEvice:LANGuage:CSV:DPOint on page 501
```

**Row Header**

Defines a header for each row or column, depending on the orientation. A header contains information on the trace, e.g. the trace index, or frequency, power or time values.

**Example:**

```
Trace=2;Source=detecting..;X[Hz]";"Trace=2;Source=detecting..;Y[dBm]"
```

Remote command:

```
:SENSe[:POWER]:SWEep:HCOPY:DEvice:LANGuage:CSV:HEADer on page 501
```

**How to Save a Hardcopy of the Power Analysis Window**

1. Select "Clk Syn/Power Sens" > "NRP Power Analysis".
2. In the diagram window, open the context-sensitive menu.
3. In the menu, select "Save... (Power Analysis)".

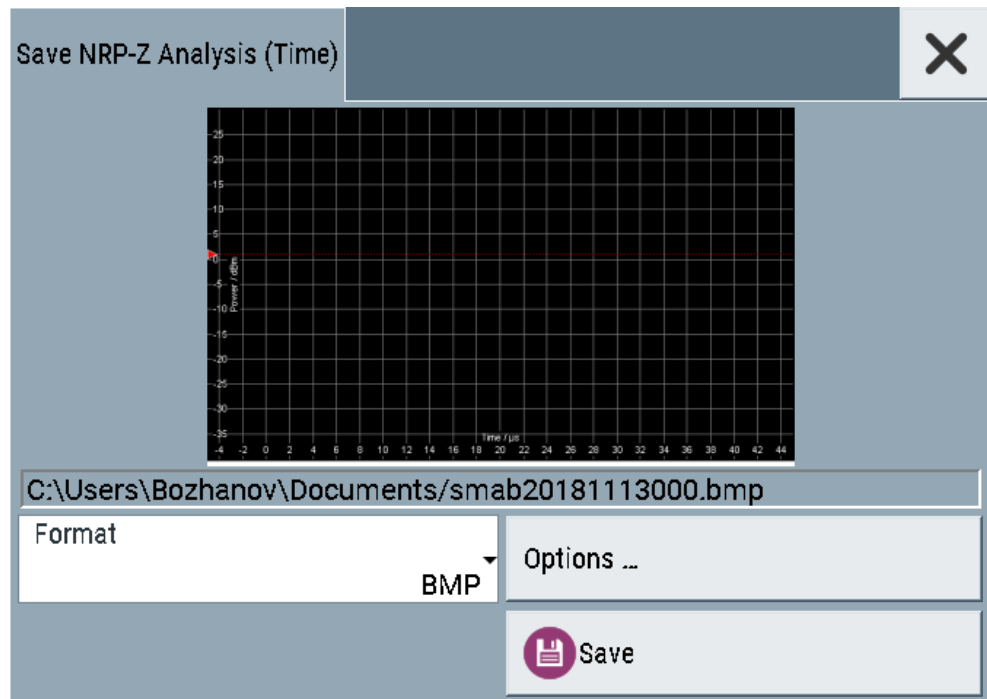

4. To define the output format, select "Format > JPG".
5. Select "Options...".
6. To enable the instrument to create output filenames, select "Automatic Naming > On".
- 7.

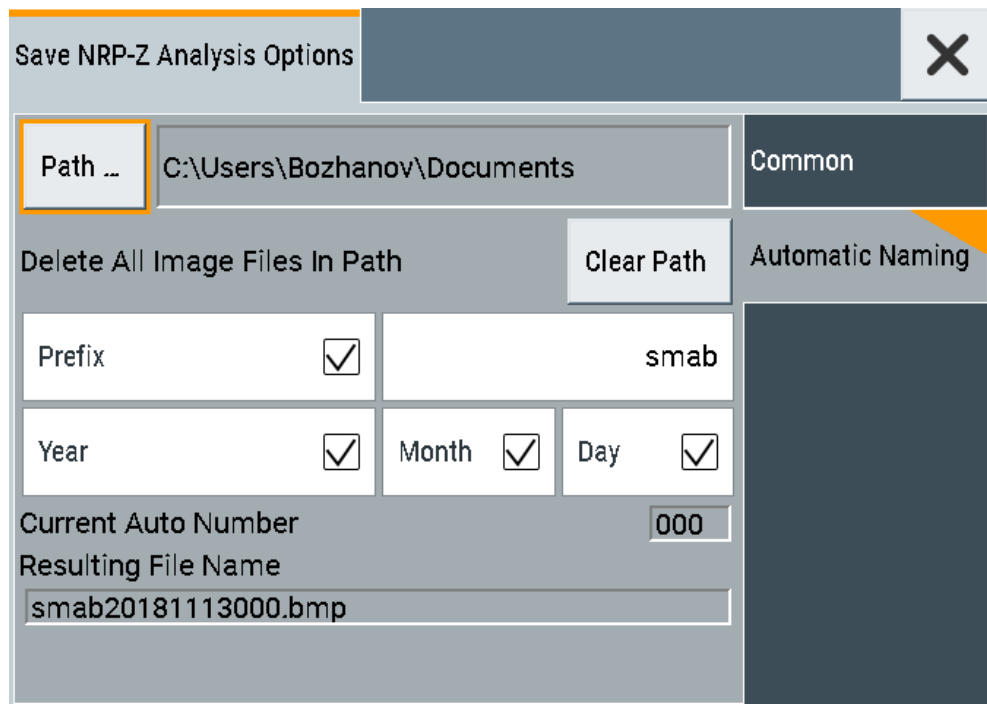

In the "Automatic Naming" tab:

- a) To change the default directory the file is saved in, select "Path" and define a path and a filename. For example, select the default directory `/var/user`.
  - b) If necessary, disable or change some of the parameters in the "Automatic Naming Settings".
  - c) Close the "Save NRP-Z Analysis Options" dialog.
8. In the "Save NRP-Z Analysis" dialog, select "Save".
- The instrument saves a hardcopy of the current instrument display as a `*.jpg` file. The filename is automatically created.
9. To print the hardcopy, connect the instrument to a LAN and:
- a) Transfer the file to a remote computer as described in [Chapter 11.9, "How to Transfer Files from and to the Instrument"](#), on page 325.
  - b) On the remote computer, navigate through the file system.
  - c) Print the selected file.
- For more information, refer to the online help of the operating system.

#### 8.4.4.8 How to Setup a Frequency Sweep Measurement

Prerequisites: the sensor is connected to the instrument and configured, see [Chapter 8.4, "Using Power Sensors"](#), on page 228.

1. Select "Clk Syn/Power Sens" > "NRP Power Analysis".
2. Select "Configure" > "Configure Measurement".
3. Set "Mode" > "Frequency".
4. Configure the measurement:
  - a) Set "Min = 8 KHz".
  - b) Set "Max = 6 GHz".
  - c) Set "Steps = 200".
5. Select the "Configure Diagram" tab. Configure the diagram, see [Chapter 8.4.4.11, "How to Configure the Power Analysis Diagram"](#), on page 283.
6. Select the "Configure Sensors" tab.
7. Select the connected sensor, e.g. "2-NRP-Z81".
8. If you want that the frequency settings of the sensor are configured differently than the generator settings, enable "Use Separate Frequ."
  - a) Set "Min = 1 MHz".
  - b) Set "Max = 10 MHz".
9. In the "Next Window List" tab, enable the "Standard View".
10. Close the "Configure" dialog.
11. Press "Start Cont" to start the measurement.

#### 8.4.4.9 How to Setup a Power Sweep Measurement

Prerequisites: the sensor is connected to the instrument and configured, see [Chapter 8.4, "Using Power Sensors"](#), on page 228.

1. Select "Clk Syn/Power Sens" > "NRP Power Analysis".
2. Select "Configure" > "Configure Measurement".
3. Set "Mode" > "Power".
4. Configure the measurement:
  - a) Set "Min = -20 dBm".
  - b) Set "Max = 30 dBm".
  - c) Set "Steps = 200".
5. Select the "Configure Diagram" tab. Configure the diagram, see [Chapter 8.4.4.11, "How to Configure the Power Analysis Diagram"](#), on page 283.
6. Select the "Configure Sensors" tab.
7. Select the connected sensor, e.g. "2-NRP-Z81".
8. If you want that the frequency settings of the sensor are configured differently than the generator settings, enable "Use Separate Frequ."
  - a) Set "1 MHz".
9. In the "Next Window List" tab, enable the "Standard View".
10. Close the "Configure" dialog.
11. Press "Start Cont" to start the measurement.

#### 8.4.4.10 How to Setup a Pulse Measurement

Prerequisites: the sensor is connected to the instrument and configured, see [Chapter 8.4, "Using Power Sensors"](#), on page 228.

1. Select "Clk Syn/Power Sens" > "NRP Power Analysis".
2. Select "Configure" > "Configure Measurement".
3. Set "Mode" > "Time".
4. Configure the measurement:
  - a) Set "Min = -5 us".
  - b) Set "Max = 45 us".
  - c) Set "Steps = 200".
5. Select the "Configure Diagram" tab. Configure the diagram, see [Chapter 8.4.4.11, "How to Configure the Power Analysis Diagram"](#), on page 283.
6. Select the "Configure Sensors" tab.

7. Select the connected sensor, e.g. "2-NRP-Z81".
8. In the "Next Window List" tab, enable the "Pulse Data View".
9. Close the "Configure" dialog.
10. In the diagram window, open the context-sensitive menu.
11. Select "Trace/Pulse Data Notifications/ Trigger".
12. Select the "Trace" tab.
13. Set "State > On".
14. Set the thresholds:
  - a) Set "Base > Voltage Related".
  - b) Set "Distal = 90%".
  - c) "Mesial = 50%".
  - d) "Proximal = 10%".
15. Select the "Pulse Data Notifications" tab.
16. Enable up to six parameters, for example:
  - "Duty Cycle"
  - "Pulse Width"
  - "Pulse Period"
  - "Off Time"
  - "Start Time"
17. Close the "Trace/Pulse Data Notifications/ Trigger" dialog.
18. Press "Start Cont" to start the measurement.

#### 8.4.4.11 How to Configure the Power Analysis Diagram

1. Select "Clk Syn/Power Sens" > "NRP Power Analysis".
2. Select "Configure" > "Configure Diagram".
3. Set "Max Level = 30 dBm".
4. Set "Min Level = -40 dBm".
5. Select "Auto Scale > Expand Only (Coarse)".
6. Enable "Show Grid".
7. Set "Background Color > Black."

## 8.5 How to Calibrate the Power Level with an R&S NRP Power Sensor

Using a R&S NRP power sensor and the user correction function of the instrument, you can compensate external frequency responses. The R&S SMA100B utilizes the readings of the power sensor and creates a correction value table for controlling the output level during operation.

### To connect the R&S NRP to the R&S SMA100B

1. Connect the power sensor.  
See [Chapter 8.4.1, "Connecting R&S NRP Power Sensors to the R&S SMA100B"](#), on page 229.
2. Select "Clk Syn/Power Sens" > "NRP Sensor Mapping".
3. If the sensor is not detected automatically, select "Scan > Start".  
The instrument scans the network and the USB connections for connected sensors and lists all detected R&S NRP sensors in the mapping table.
4. In the "Mapping" column, assign the sensor to a sensor channel, see [Chapter 8.4.2, "NRP Sensor Mapping"](#), on page 230.
5. Close the dialog.

### To configure and calibrate the R&S NRP in the R&S SMA100B

Provided the power sensor is connected to the R&S SMA100B and is assigned to a sensor channel, we recommend that you calibrate and configure the power sensor in the "NRP Power Viewer" dialog.

1. Select "Level" > "RF ON > Off"
2. Select "Clk Syn/Power Sens" > "NRP Power Viewer".

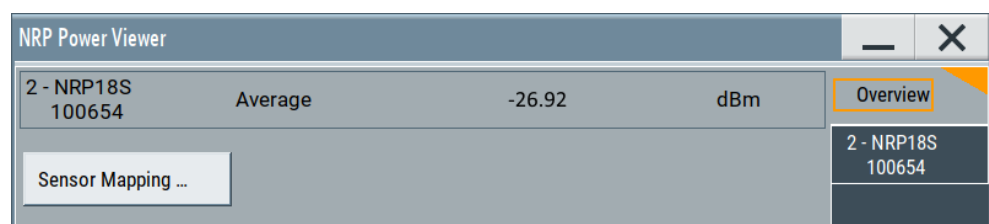

3. If the R&S SMA100B has detected several connected power sensors, select the tab of the sensor you want to use.
4. Select "Zero" to start zeroing of the sensor.  
**Note:** Always turn the RF power off or disconnect the sensor from RF before zeroing, since the function calibrates the power sensor at zero signal power.  
The zeroing process takes a few seconds, depending on the power sensor type.
5. Configure additional parameters for the selected sensor as required.



6. Select "State > On".
7. Close the dialog.

### To create user correction data with an R&S NRP and the R&S SMA100B

We assume, that the power sensor is connected, assigned and ready for operation.

1. Select "Level" > "User Correction".

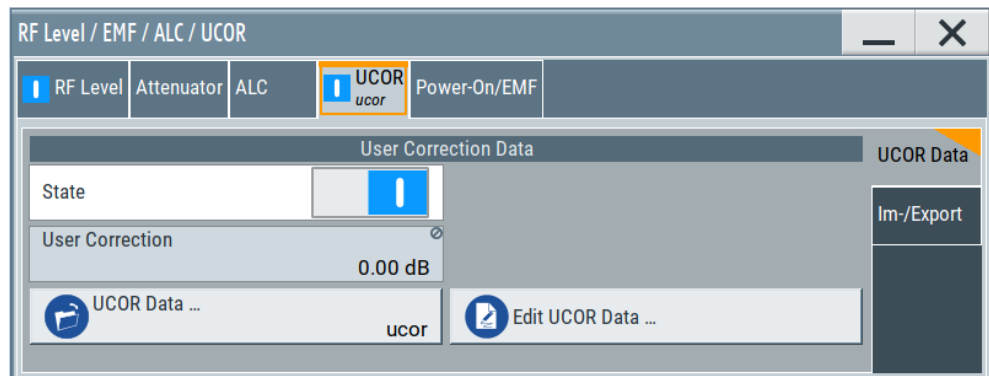

2. Select "UCOR Data" > "UCOR Data...."
3. Create a file: "New" > Filename and confirm with "OK".
4. Select the new file with "Select".
5. Select "Edit UCOR Data...".
6. Select "Edit" > "Fill".  
The "Fill Table" dialog enables you to fill in the values of the columns automatically.
7. To fill in the frequency column:

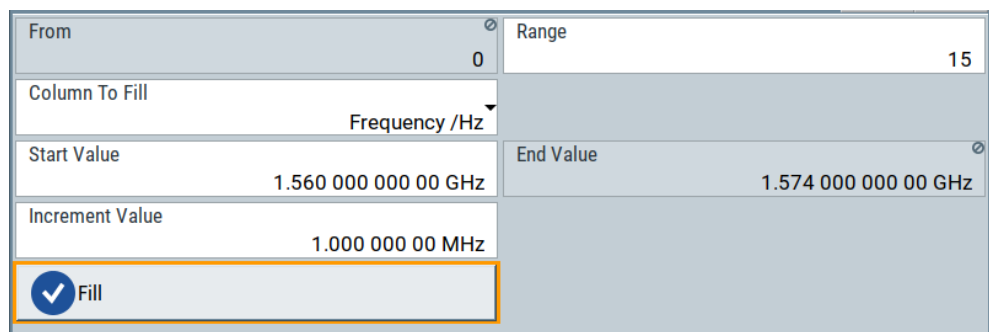

- a) Select "Select Column To Fill > Frequency / Hz".
- b) Select "Range > e.g. 15" to determine the number of values.
- c) Select "Start Value > e.g. 1.56 GHz".
- d) Select "Increment Value > e.g. 1 MHz", to determine the frequency steps.
- e) Select "Fill", to insert the frequency values.

The "Fill" function also fills the column of the "Correction Value / dB" values with a predefined value, since empty cells lead to the data loss of the entire line. If you need different values, you can change them manually, or you can use the automatic function "Fill with Sensor" as described in the next steps.

8. Select "Fill with Sensor".

The "Fill User Correction Data With Sensor" dialog provides an overview of the sensor configuration.

9. Select "Execute".

The R&S SMA100B successively sets each frequency point, reads the measured power of the sensor and fills in the value in the correction table.

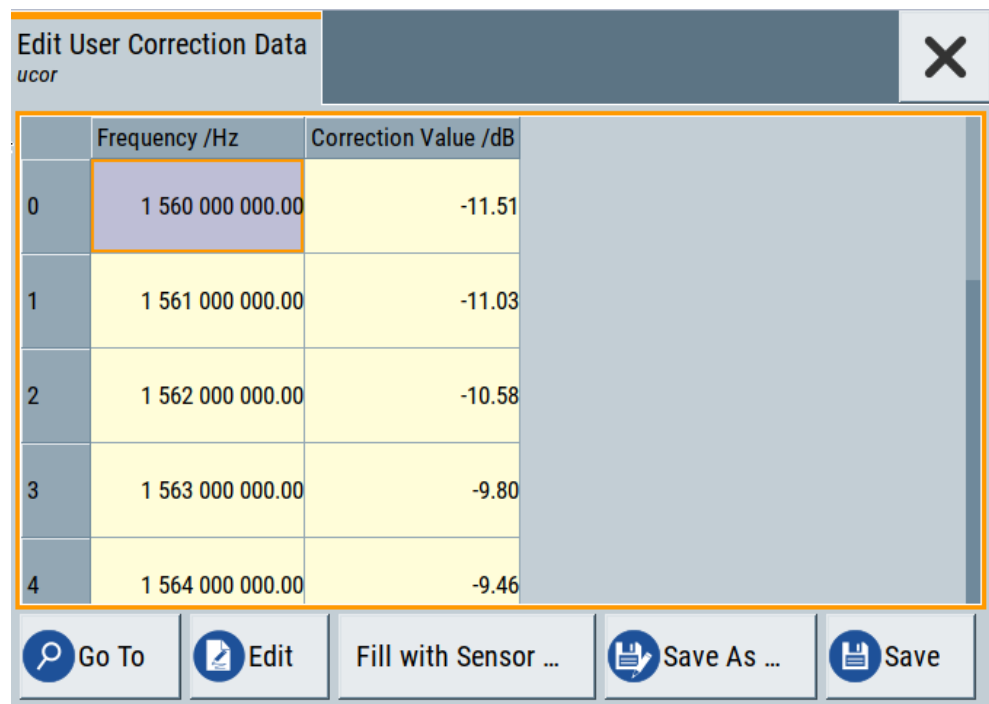

	Frequency /Hz	Correction Value /dB
0	1 560 000 000.00	-11.51
1	1 561 000 000.00	-11.03
2	1 562 000 000.00	-10.58
3	1 563 000 000.00	-9.80
4	1 564 000 000.00	-9.46

10. Select "Save" to save the data in the file.
11. Close the dialog.

#### To perform power leveling calibration with user correction data

We assume that a user correction file is available in the user directory of the R&S SMA100B or on a memory stick or in a shared directory.

If you have created and saved the file immediately before this step, the file is loaded in the "User Correction" dialog automatically. Otherwise you can load a previously saved file.

1. Select "Level" > "User Correction".
2. Select "UCOR Data" > "UCOR Data...", if there is no file loaded already.
3. Select the directory and file you want to use.

4. Load the file with "Select".
5. To view the file content, select "Edit UCOR Data...".
6. Select "UCOR Data" > "State" > "On" to apply the user correction values.

When you activate the RF output, the R&S SMA100B considers the user correction data and adjusts the signal level accordingly to compensate external frequency responses.

## 9 Reference Oscillator

The R&S SMA100B is equipped with an internal reference oscillator that generates a reference frequency of 10 MHz. It is used as internal reference source for the synthesizer.

Alternatively, you can apply an external reference signal. If equipped with the required options, the R&S SMA100B can process external reference frequency in the range 1 MHz to 100 MHz and the 1 GHz reference frequency.

Regardless of the used reference source (internal or external), the R&S SMA100B always provides the configured reference frequency at the output. You can use it, for example to synchronize several interconnected instruments, see [Chapter 9.5, "Using the Reference Frequency for Instruments Synchronization"](#), on page 294, for an overview of typical test situations.

The reference oscillator settings are not affected by an instrument preset ([Preset] key or \*RST) and the "Save/Recall" function. They are reset only by factory preset.

### 9.1 Required Options

R&S SMA100B base unit equipped with the following options:

- 100 MHz, 1 GHz ultra low noise reference input and output (R&S SMAB-K703)
- 1 MHz to 100 MHz flexible reference input (R&S SMAB-K704)

For more information, see data sheet.

### 9.2 Reference Frequency Settings

Access:

1. Select ""Frequency" > Reference Frequency".

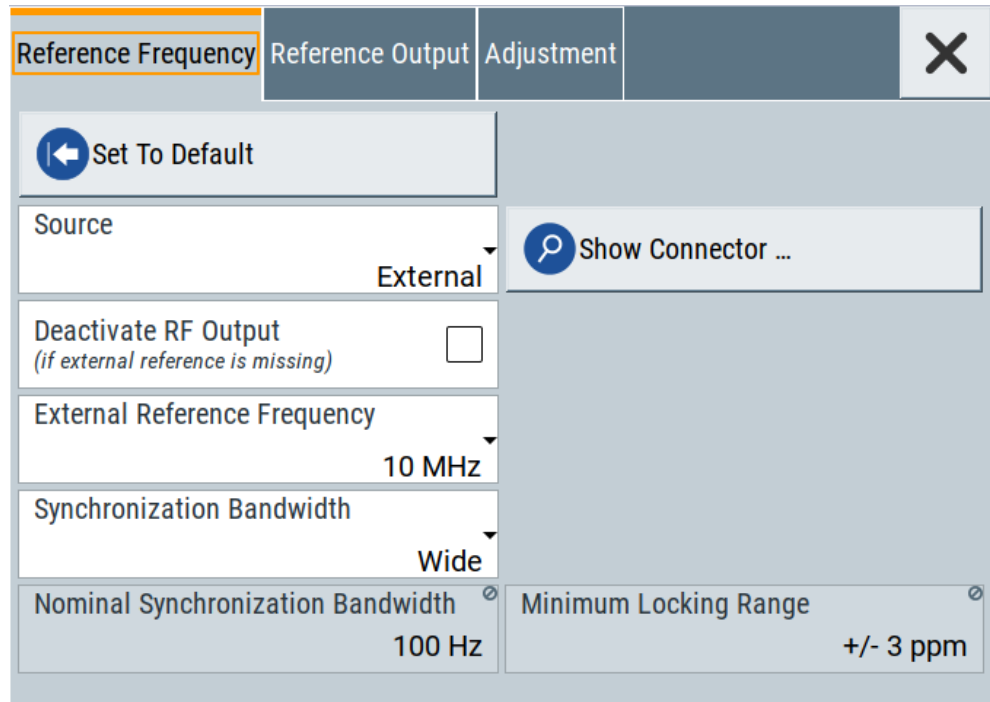

In the "Reference Frequency" tab, you can select the reference frequency signal source and the frequency and synchronization bandwidth mode of an external reference signal.

2. Observe the information on the home screen, "Frequency" tile.

The "Frequency" tile indicates the current reference oscillator configuration, including the reference oscillator source, external reference frequency (rounded value) and output connector. A warning symbol in the "Frequency" tile indicates a missing external source.

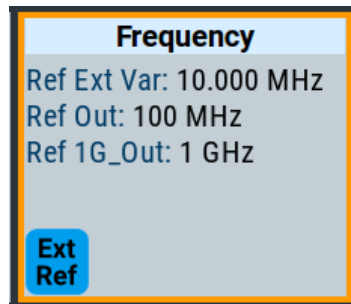

The remote commands required to define these settings are described in [Chapter 14.16.12, "SOURCE:ROSCillator Subsystem"](#), on page 671.

**Settings:**

<a href="#">Set to Default</a> .....	290
<a href="#">Source</a> .....	290
<a href="#">Show Connector</a> .....	290
<a href="#">Deactivate RF Output (if external reference is missing)</a> .....	290

External Reference Frequency.....	290
Variable Reference Frequency.....	291
Synchronization Bandwidth.....	291
Nominal Synchronization Bandwidth.....	291
Minimum Locking Range.....	291
External Tuning Active.....	292
External Tuning Slope.....	292

### Set to Default

Calls the default settings.

Remote command:

`[ :SOURce ] :ROSCillator :PRESet` on page 672

### Source

Selects the reference frequency source.

"Internal" Uses the internal reference oscillator, either with calibrated or a user-defined [Adjustment Value](#).

"External" Uses an external reference signal.

**Note:** If the external reference is missing, the R&S SMA100B issues a warning message and indicates the icon  (external reference missing).

To set the frequency of the external reference, see "[External Reference Frequency](#)" on page 290.

Remote command:

`[ :SOURce ] :ROSCillator :SOURce` on page 672



### Show Connector

Accesses a dialog that displays the physical location of the selected connector on the front/rear panel of the instrument.

### Deactivate RF Output (if external reference is missing)

Turns off the RF output when the external reference signal is selected, but no signal is supplied.

This function prevents that no improper RF signal due to the missing external reference signal is used for measurements. A message indicates that the RF output is deactivated.

Remote command:

`[ :SOURce ] :ROSCillator :EXTernal :RFOFf [ :STATe ]` on page 673

### External Reference Frequency

Selects the frequency of the external reference signal.

Set the reference output frequency with the parameters in the [Reference Output Settings](#) dialog.

"10 MHz" Selects 10 MHz for the external reference frequency signal.

"100 MHz, 1 GHz"

Option: R&S SMAB-K703/-K704  
Selects the external reference frequency.

"Variable"

Option: R&S SMAB-K704  
The external reference signal has an arbitrary frequency, within the permissible range from 1 MHz to 100 MHz.

Remote command:

`[ :SOURce ] :ROSCillator :EXTernal :FREQuency` on page 673

### Variable Reference Frequency

Option: R&S SMAB-K704

Sets the variably settable external reference frequency.

Remote command:

`[ :SOURce ] :ROSCillator :EXTernal :FREQuency :VARiable` on page 673

### Synchronization Bandwidth

Selects the synchronization bandwidth for an external reference signal.

The resulting bandwidth is indicated by the parameter [Nominal Synchronization Bandwidth](#).

"Narrow"

The internal reference oscillator is synchronized to the external signal with narrow bandwidth.

This setting is recommended if the phase noise of the external signal is worse than the phase noise of the internal OCXO.

"Wide"

Synchronizes the internal oscillator to the external signal with the maximum possible bandwidth.

This mode is the recommended standard mode and for precise reference sources of high spectral purity.

**Note:** If the frequency of the external reference signal is outside the locking range of the internal reference oscillator, spurs due to the difference of the internal and external reference frequency are generated in the reference PLL.

The R&S SMA100B issues an error message.

For more information, see data sheet.

Remote command:

`[ :SOURce ] :ROSCillator :EXTernal :SBANDwidth` on page 673

### Nominal Synchronization Bandwidth

Indicates the nominal synchronization bandwidth for the selected [External Reference Frequency](#) and the [Synchronization Bandwidth](#).

Remote command:

`[ :SOURce ] :ROSCillator :EXTernal :NSBandwidth?` on page 674

### Minimum Locking Range

Indicates the minimum locking range for the selected [External Reference Frequency](#) and the [Synchronization Bandwidth](#).

Remote command:

`[ :SOURce ] :ROSCillator :EXTernal :MLRange?` on page 674

### External Tuning Active

For "Source > Internal", activates the EFC (external frequency control).

EFC is a function that transforms an external tuning voltage into frequency shift, where the value range of the resulting frequency is a technical characteristic listed in the data sheet.

See the data sheet also for information on the sensitivity, input voltage range, impedance and maximum bandwidth for external tuning signal.

Remote command:

`[ :SOURce ] :ROSCillator :INTernal :TUNing [ :STATe ]` on page 672

### External Tuning Slope

Sets the sensitivity of the external tuning voltage.

Remote command:

`[ :SOURce ] :ROSCillator :INTernal :TUNing :SLOPe` on page 672

## 9.3 Reference Output Settings

Access:

1. Select ""Frequency" > Reference Frequency".
2. Select "Reference Output".

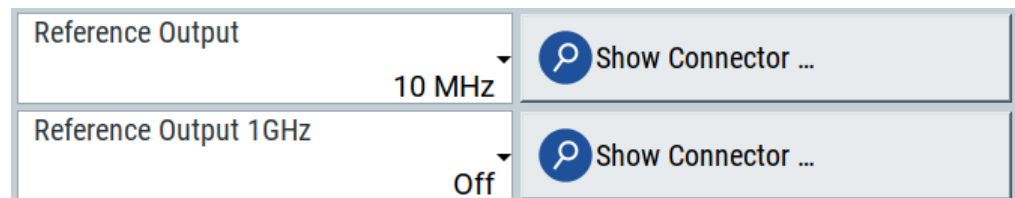

In the "Reference Output" tab, you can set the reference frequency value at the output connectors.

As a result of parameter dependencies, "Preset This Parameter" sometimes does not affect output dialogs.

The remote commands required to define these settings are described in [Chapter 14.16.12, "SOURce:ROSCillator Subsystem"](#), on page 671.

### Settings:

<a href="#">Reference Output/1 GHz Reference Output</a> .....	292
<a href="#">Show Connector</a> .....	293

### Reference Output/1 GHz Reference Output

Selects frequency reference output signal for downstream instruments.



"Off"	Deactivates the reference signal output.
"10 MHz"	Derives a signal with 10 MHz frequency from the internal reference oscillator and provides this signal at the output.
"100 MHz"	Option: R&S SMAB-K703/-K704 Derives a signal with 100 MHz frequency from the internal reference oscillator and provides this signal at the output.
"1 GHz"	Provides the 1 GHz reference frequency signal at the output.
"Input Signal (loop through)"	Option: R&S SMAB-K703/-K704 Passes the external reference frequency to the output directly.

Remote command:

[\[:SOURce\]:ROSCillator:OUTPut:FREQuency:MODE](#) on page 674

[\[:SOURce\]:ROSCillator:OUTPut:ALternate:FREQuency:MODE](#) on page 675



#### Show Connector

Accesses a dialog that displays the physical location of the selected connector on the front/rear panel of the instrument.

## 9.4 Adjustment Settings

Access:

1. Select "Frequency" > "Reference Frequency".
2. Select "Adjustment".

Adjustment Active <input checked="" type="checkbox"/>	Adjustment Value	0
---	------------------	---

#### Settings:

<a href="#">Adjustment Active</a> .....	293
<a href="#">Adjustment Value</a> .....	294

#### Adjustment Active

Selects the adjustment mode.

"Off"	Uses the calibrated internal reference frequency.
"On"	Allows you to apply a deviation to the internal reference frequency, according to your requirements. Enter the value in the <a href="#">Adjustment Value</a> field.

Remote command:

[\[:SOURce\]:ROSCillator\[:INTernal\]:ADJust\[:STATe\]](#) on page 676

**Adjustment Value**

Sets a user-defined adjustment value for the internal reference frequency. This value takes effect when it is activated with [Adjustment Active](#).

- "0" represents the calibrated state.
- The setting range depends on the reference oscillator type and its factory calibration value.

**Note:**

The setting is not affected by an instrument preset ([Preset] key or \*RST) and the "Save/Recall" function. It is reset only by factory preset.

Remote command:

[\[:SOURce\]:ROSCillator\[:INTernal\]:ADJust:VALue](#) on page 675

## 9.5 Using the Reference Frequency for Instruments Synchronization

Test setups with two or more instruments often require that the instruments use a common reference frequency. Depending on the availability of external reference frequency source and its quality, the instruments are connected and configured in different ways.

This section gives an overview of the possible test setups and the related settings. The following situations are considered:

- External reference source is not available or the **built-in reference oscillator** is of better quality than the external source (see ["Distributing the internal 10 MHz reference signal to further instruments"](#) on page 294)
- **Clean external reference source** with quality exceeding the quality of the built-in reference oscillator (see ["Using external reference source"](#) on page 296)
- **Interfered or noisy external reference signal** (see ["Deriving 10 MHz from the external reference frequency"](#) on page 296)
- **1 GHz reference coupling** for phase coherence of the RF signals with enhanced long-term phase stability (see ["Sharing the 1 GHz reference frequency to obtain phase-coherent signals"](#) on page 295)

**Connectors overview**

Use the "Show Connector" function to indicate the connector on the front/real panel:

- ["Ref In/Ref Out"](#) on page 46
- 1GHz ["Ref In/Ref Out"](#) on page 46
- ["EFC"](#) on page 46

**Distributing the internal 10 MHz reference signal to further instruments**

The internal reference oscillator provides the reference frequency:

- Internal  $f_{ref} = 10 \text{ MHz}$  (10 MHz at connector Ref Out)

## Using the Reference Frequency for Instruments Synchronization

- Source = "Internal"
- Reference Output/1 GHz Reference Output = "10 MHz"
- Optional:
  - External Tuning Active = "On"
  - External Tuning Slope = "Low"

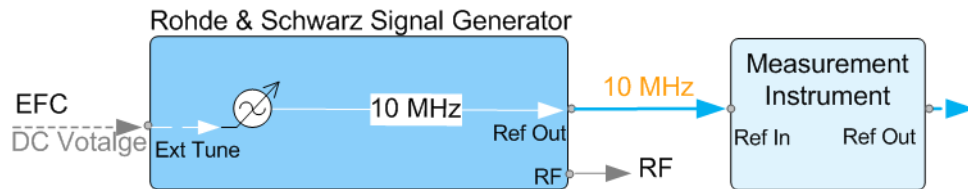

**Figure 9-1: Synchronizing instruments using the internal 10 MHz reference signal of the R&S SMA100B**

EFC = External frequency control  
 EFC, Ref In, Ref Out = Connectors

In phase noise measurement systems, for example, you can also use the EFC (external frequency control) function and shift the frequency. EFC is a function that transforms an external tuning voltage into frequency shift, where the value range of the resulting frequency is a technical characteristic listed in the data sheet. See the data sheet also for information on the sensitivity, input voltage range, impedance and maximum bandwidth for external tuning signal.

Consider the following interdependency:

- EFC in combination with an external PLL  
 If the EFC is applied in combination with an external PLL (phase locked loop), the PLL bandwidth must be smaller than the bandwidth of the external tuning signal.
- FM-DC mode  
 If the measurement requires higher PLL bandwidth, we recommend that you use the external FM modulation (DC coupling) in low noise mode.  
 The FM-DC mode yields a fixed tuning sensitivity that is independent of the RF output frequency and corresponds to the selected FM deviation.

### Sharing the 1 GHz reference frequency to obtain phase-coherent signals

Compared to 10 MHz, a 1 GHz reference signal significantly improves the achievable phase stability between two signal sources. Because the synchronization frequency increases by a factor of 100, the relative phase fluctuations between the sources can be reduced.

#### 1 GHz at connector Ref In 1GHz and 1 GHz at Ref Out 1GHz

- External  $f_{\text{Ref}} = 1 \text{ GHz}$
- Source = "External"
- External Reference Frequency = "1 GHz"
- 1GHz Reference Output = "1 GHz"

### Using external reference source

If you have a clean external reference signal with 10 MHz or 100 MHz frequency, for example, you can **directly pass it to the output**. The signal quality remains the same.

#### 10 MHz, 100 MHz at connector Ref Out and Ref In

- External  $f_{\text{Ref}} = 10 \text{ MHz}$  or  $100 \text{ MHz}$   
(earlier RF hardware versions: 5 MHz, 10 MHz, 13 MHz)
- **Source** = "External"
- **Reference Output** = "10 MHz, 100 MHz" or "Input Signal (loop through)"  
(earlier RF hardware versions: 5 MHz, 10 MHz, 13 MHz)
- Set the synchronization bandwidth according to the requirements of the application.

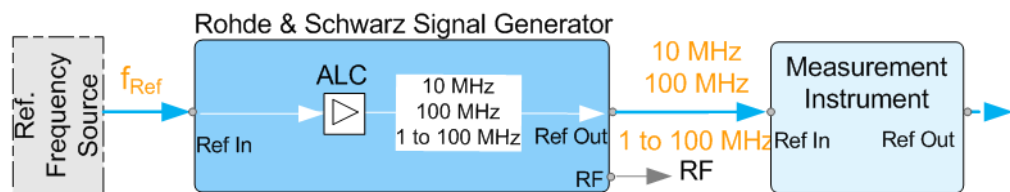

**Figure 9-2: Synchronizing instruments with a 10 MHz external reference signal**

Ref. Frequency Source = e.g., Rohde & Schwarz signal analyzer

$f_{\text{Ref}}$  = 10 MHz, 100 MHz, 1 MHz to 100 MHz external reference frequency

Ref In, Ref Out = Connectors

You can forward reference frequency between 1 MHz and 100 MHz directly to the output in the same way.

- External  $f_{\text{Ref}} = 1 \text{ MHz to } 100 \text{ MHz}$   
(**1 MHz to 100 MHz at connector Ref In and Ref Out**)
- **Source** = "External"
- **Variable Reference Frequency** = "Variable"
- **External Reference Frequency** = current external frequency
- **Reference Output** = "Input Signal (loop through)" or specify the reference frequency the synchronized instrument supports
- Set the synchronization bandwidth according to the requirements of the application.

### Deriving 10 MHz from the external reference frequency

10 MHz reference frequency can be derived from the following external reference signals:

- 10 MHz from internal oscillator locked to external input
- 100 MHz and 1 GHz external reference signals
- External reference signal between 1 MHz and 100 MHz
- If the external reference signal is interfered (noisy)

## Using the Reference Frequency for Instruments Synchronization

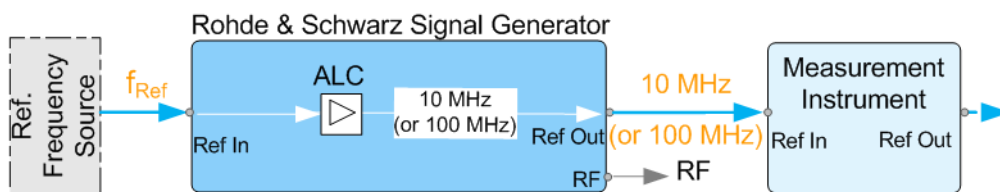

**Figure 9-3: Synchronizing instruments with 10 MHz (derived from an external reference frequency)**

Ref. Frequency Source = e.g., Rohde & Schwarz signal analyzer

$f_{\text{Ref}}$  = 10 MHz, 100 MHz, 1 MHz to 100 MHz, 1 GHz\*\* external reference frequency

\*\* = 1 GHz uses Ref In 1 GHz connector

Ref In, Ref Out = Connectors

**1 GHz, 1 MHz to 100 MHz at connector Ref In 1 GHz/Ref In and 10 MHz at Ref Out**

- E.g., external Ref.  $f_{\text{ref}} = 100 \text{ MHz}$
- Source = "External"
- External Reference Frequency = "100 MHz"
- Reference Output/1 GHz Reference Output = "10 MHz"
- Synchronization Bandwidth = "Narrow"

## 10 Clock Synthesis

The clock synthesis provides a separate system clock with a freely selectable frequency for test setups that require an additional clock reference. For example, in a test setup that uses an A/D converter, the required system clock for data sampling can be provided without the need of additional signal generator.

### Output connectors

The generated clock reference is synchronized to the selected reference clock of the signal generator (internal or external). The differential signal is output at the [Clk Syn] and [Clk Syn N] connectors.

### Required options

- Option frequency R&S SMAB-B10x
- Option differential clock synthesis up to 3 GHz R&S SMAB-B29
- Option clock synthesis extension 6 GHz R&S SMAB-K722 (requires at least R&S SMAB-B106)

For more information, see data sheet.

### Settings

Access:

1. Select "Clk Syn/Power Sens > Clock Synthesis".

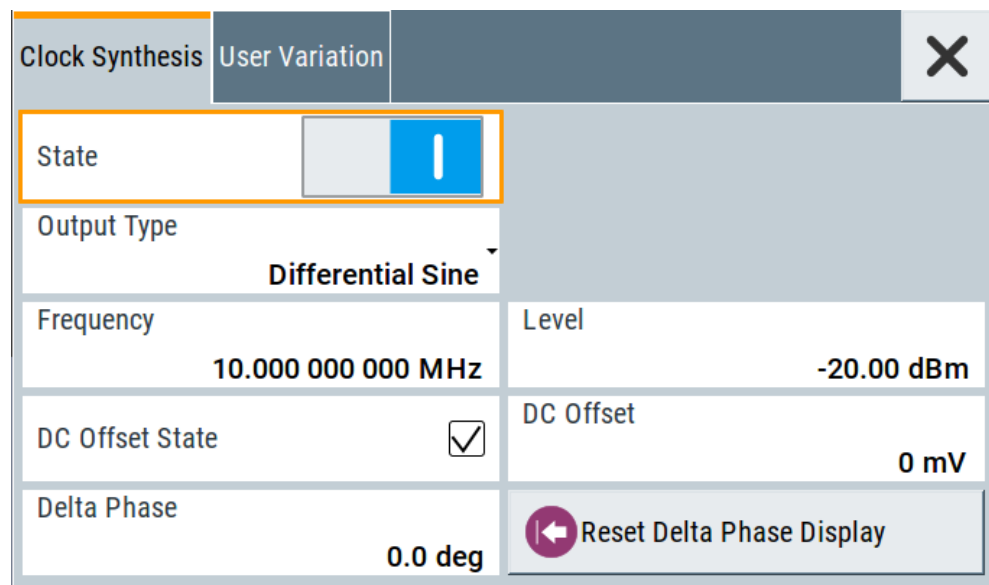

2. Select "User Variation" to set the step width to be used when setting the clock frequency using the rotary knob.

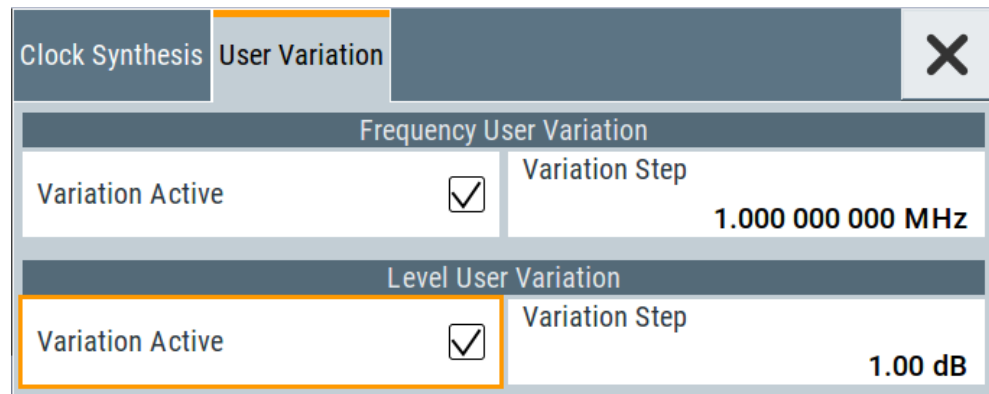

3. Observe the information on the home screen, "Clk Syn/Power Sens" tile.

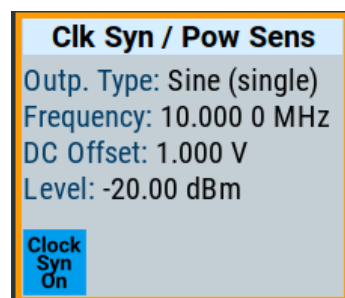

The "Clk Syn/Power Sens" tile indicates that clock synthesis is activated and gives an overview of the key parameters.

## Settings

State .....	299
Output Type.....	299
Frequency .....	300
Level .....	300
DC Offset State .....	300
DC Offset .....	301
Voltage.....	301
Delta Phase.....	301
Reset Delta Phase Display.....	301
User Variation.....	301
└ Variation Active.....	301
└ Variation Step.....	301

## State

Activates/deactivates generation of a system clock.

The signal is output at the [Clk Syn] connector.

Remote command:

:CSYNthesis:STATE on page 455

## Output Type

Defines the shape of the generated clock signal.

"Single-Ended/Differential Sine"

Sine signals with user-definable amplitude.

"Differential Square"

Squared signal with fixed amplitude.

"CMOS"

CMOS-like signal with user-definable amplitude and limited frequency range.

Remote command:

`:CSYNthesis:OTYPe` on page 456

### Frequency

Sets the frequency of the generated clock signal.

Output Type	Min. frequency	Max. frequency
Single-ended sinus Differential sinus	100 kHz	6 GHz
Differential square	10 MHz	6 GHz
CMOS	100 kHz	200 MHz

Remote command:

`:CSYNthesis:FREQuency` on page 456

### Level

For **Output Type** = "Single-Ended/Differential Sine", sets the amplitude of the generated clock signal.

Remote command:

`:CSYNthesis:POWer` on page 456

### DC Offset State

Activates a DC offset for both clock synthesis signal outputs.

The DC offset can be used e.g. to shift the clock synthesis output signal into the trigger threshold of some logic elements.

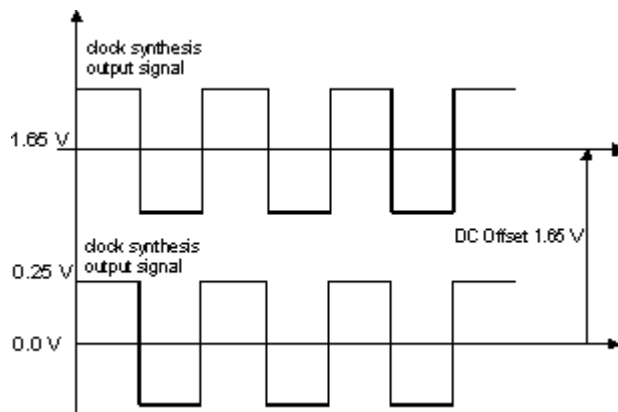

Figure 10-1: Example: DC offset = 1.65V and Output Type = Differential Square



Remote command:

`:CSYNthesis:OFFSet:STATe` on page 457

#### DC Offset

Sets the value of the DC offset for both clock synthesis signal outputs.

Remote command:

`:CSYNthesis:OFFSet` on page 457

#### Voltage

For **Output Type** = "CMOS", sets the high-level of the output signal.

Remote command:

`:CSYNthesis:VOLTagE` on page 457

#### Delta Phase

Shifts the phase of the generated clock signal.

Remote command:

`:CSYNthesis:PHASe` on page 457

#### Reset Delta Phase Display

Resets the parameter **Delta Phase**.

#### User Variation

Defines and activates a user-defined step width for varying the frequency or level with the rotary knob.

If disabled, the step width varies in steps of one unit at the cursor position.

#### Variation Active ← User Variation

Activates the set user-defined step width.

Remote command:

`:CSYNthesis:FREQuency:STEP:MODE` on page 458

`:CSYNthesis:POWer:STEP:MODE` on page 458

#### Variation Step ← User Variation

Sets the user-defined step width.

Remote command:

`:CSYNthesis:FREQuency:STEP` on page 459

`:CSYNthesis:POWer:STEP[:INCRement]` on page 458

# 11 File and Data Management

The R&S SMA100B uses files to save all instrument data. The instrument allows you to store and to load instrument settings, and to import and to export user data for processing in another instrument or later. Finally, you can create a screenshot of the current settings displayed on the screen and save it as a file.

This section focuses on the functions provided for managing of user data files and covers the topics listed below.

For information on the related remote control commands, refer to [Chapter 14.5, "Memory Subsystem"](#), on page 441.

For information on how to save the displayed setting in a file, refer to [Chapter 11.10, "Creating Screenshots of Current Settings"](#), on page 331.

• <a href="#">About the File System</a> .....	302
• <a href="#">Restoring the (Default) Instrument Configuration</a> .....	305
• <a href="#">Protecting Data</a> .....	310
• <a href="#">Saving and Recalling Instrument Settings</a> .....	311
• <a href="#">Accessing Files with User Data</a> .....	315
• <a href="#">Exporting and Importing Remote Command Lists</a> .....	317
• <a href="#">Loading, Importing and Exporting Lists</a> .....	318
• <a href="#">Using the File Manager</a> .....	318
• <a href="#">How to Transfer Files from and to the Instrument</a> .....	325
• <a href="#">Creating Screenshots of Current Settings</a> .....	331

## 11.1 About the File System

Depending on the contained information, two file groups can be distinguished: system and user files.



Due to security reasons, system files and the system directory are protected and therefore not accessible.

The scope of this section is only the files with user data.

This section is an overview of the R&S SMA100B file system and covers the following topics:

- ["Types of user data"](#) on page 303
- ["File storage location"](#) on page 303
- ["File handling"](#) on page 304
- ["File naming conventions"](#) on page 304
- ["File extensions"](#) on page 304
- ["File contents"](#) on page 305

### Types of user data

Depending on the **content**, the **user data** can be roughly divided into the following data types:

- *Settings*, e.g. the current instrument settings, can be saved and loaded later or used in other instrument of the same kind.  
See [Chapter 11.4, "Saving and Recalling Instrument Settings"](#), on page 311
- *SCPI scripts*, a series of commands that can be run to perform a task.  
See [Chapter 11.6, "Exporting and Importing Remote Command Lists"](#), on page 317
- Externally or internally generated *lists*, e.g. user correction lists, or data lists can be loaded in the instrument.  
See [Chapter 11.7, "Loading, Importing and Exporting Lists"](#), on page 318 and [Chapter 11.5, "Accessing Files with User Data"](#), on page 315

Depending on the **data storage method**, user data can be:

- *Persistent*, i.e. user files that are recorded on the data storage.  
Data is preserved when instrument is powered off and can be accessed and modified subsequently.
- *Temporary*, i.e. volatile data that the instrument retains while it is powered on.  
Volatile data is immediately lost when the R&S SMA100B is switched off.

### File storage location

Without any additional measures, the R&S SMA100B stores user files on the internal memory, the removable memory, or if connected, on a memory stick.

Both, the user directory `/var/user/` on the internal memory or the `/usb/` directory on the memory stick, can be used to **preserve** user-defined data. Any directory structure can be created.

The `/var/volatile` directory serves as a RAM drive and can be used to protect sensitive information. The data is available **temporarily**.

If option R&S SMAB-B85 is installed, the R&S SMA100B maps the user directory to the removable memory. If a memory is mounted, user data is saved there. Otherwise user data is redirected to the volatile memory.

### Default storage location

The R&S SMA100B stores user data in the user directory.

Depending on the installed options, the user directory is physically located on the internal memory or on the removable memory.

In the file system, user directory is always indicated as `/var/user/`.

In manual control, you access this directory via the "File Manager", see [Chapter 11.8, "Using the File Manager"](#), on page 318. In remote control, you can query it with the command `:SYSTem:MMEMory:PATH:USER?`.

To query and change the default directory used for mass storage, use the command `:MMEMory:CDIRectory`.

## File handling

To *access files* and the file system of the instrument or to use the general file management functions such as copying and moving data, use the standard "File Manager" dialog.

See [Chapter 11.8, "Using the File Manager"](#), on page 318.

To *transfer files* from and to the instruments or to exchange files, use one of the following alternatives:

- Connect a memory stick to one of the USB interfaces.  
The instrument recognizes automatically a connected memory stick and assigns the `/usb/` drive to it.
- Connect the instrument to a LAN.  
An instrument connected to a LAN supports two standard file transfer methods from a remote client:
  - FTP (file transfer protocol)
  - File sharing according to the SAMBA/SMB (server message block) protocol.Both file transfer methods access the folder `/user`, that is the `/var/user/` folder on the instrument.  
For step-by-step description, see [Chapter 11.9, "How to Transfer Files from and to the Instrument"](#), on page 325.
- Map a network folder or a computer to an instrument connected to a LAN.  
A mapped network folder is indicated as `/shares/<"Local Folder">`.  
For step-by-step description, see [Chapter 11.8.4, "How to Map a Network Folder"](#), on page 322.

## File naming conventions

To enable files to be used in different file systems, consider the following file naming conventions:

- The *filename* can be of any length and *is case-sensitive*, i.e it is distinguished between uppercase and lowercase letters.
- All letters and numbers are permitted (numbers are, however, not permitted at the beginning of the filename).
- Avoid using special characters.
- Do not use slashes "\" and "/". These symbols are used in file paths.
- Avoid using the following filenames: `CLOCK$`, `CON`, `COM1` to `COM4`, `LPT1` to `LPT3`, `NUL` or `PRN`  
They are reserved by the operating system.

## File extensions

The R&S SMA100B distinguishes the files according to their extensions; each type of file is assigned a specific file content and also a specific file extension. The extension is usually of no consequence to you since access to the files occurs in the individual dialogs where only the relevant type of file is available. For example, files with user correction data can only be saved and loaded in the "UCOR" dialog.

See [Chapter A.3, "Extensions for User Files"](#), on page 777 for an overview of the supported file extensions.

### File contents

To maintain the file size and to accelerate the loading and processing times, not all instrument settings but rather the settings in state different than the preset one are stored. Considered is also configuration data for the operating elements and lists with user data, e.g. dialog positions and a list of user correction data. However, if a list data is part of the instrument settings, a reference to this list is stored, not the list itself.

This approach ensures that the created files contain only relevant information and allows you to transfer instrument settings even between different equipped signal generators. During the recall process, the instrument interprets only the relevant settings; all non-referenced parameters are set to their preset values. Error messages indicate the settings which cannot be implemented, like referencing non-existing lists or the attempt to activate settings which are not supported by the instrument.



Network settings and remote settings cannot be saved and restored.

## 11.2 Restoring the (Default) Instrument Configuration

The R&S SMA100B has various options to set default settings. You can preset the R&S SMA100B to an initial state at any time as a known starting point for configurations. It is often useful as a first step in troubleshooting when unusual results arise.

The graph on [Figure 11-1](#) shows the impact of the particular reset functions.

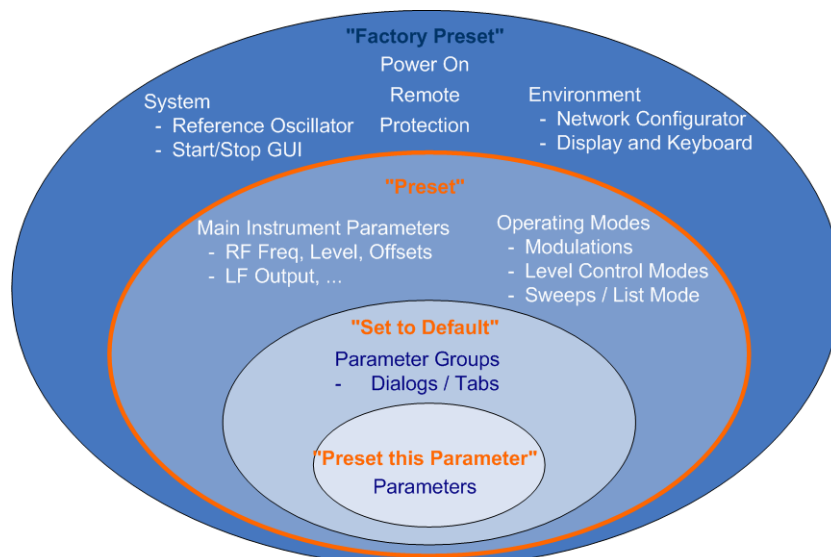

*Figure 11-1: Parameter and operating modes, reset by the respective preset functions*

### Overview of the characteristics of the preset functions

Select the preset option that most fits to your particular application:



- [Preset]  
It is the most frequently used function.  
A [Preset](#) executes a defined instrument setup to provide an initial instrument state as a basis for a new configuration. It resets all parameters and switching states, including also the states of inactive operating modes.  
Network, remote access or system settings are retained.
- ▶ To execute a preset, press the [Preset] key at the front panel.

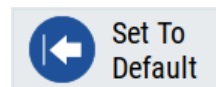

- "Set to Default"  
[Set To Default](#) relates to individual dialogs or tabs and resets the associated settings of the corresponding dialog. All other settings are retained.
- ▶ To reset the grouped settings, click "Set To Default".



- "Preset this parameter"  
Sets a single parameter to its default value.
- ▶ To reset an individual parameter: Open its context-sensitive menu and select "Preset this parameter...".

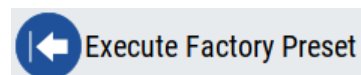

- "Factory Preset"  
A factory preset is the most profound preset function that resets almost all instrument settings, including reference oscillator, network and remote access settings.  
Retained are the following settings:
    - Security, password, and settings protected by these passwords
    - User-defined data, like setups or data lists
    - Settings that relate to an integration of the instrument in a measurement setup.
  - ▶ To restore the factory defaults, select [System Config > Setup > Settings > Factory Preset](#).
- Note:** Perform a "Factory Preset" only if it is necessary. After a "Factory Preset", the network connection to the instrument no longer exists.

**Presetting the instrument to a user-defined instrument state**

The reset functions set the parameters and operating modes to default values predefined by the factory. Alternatively to these default settings, you can:

- Define user-specific recall settings to be restored after a preset (see [Chapter 11.2.3, "How to Recall User Settings Automatically after Preset"](#), on page 309)
- Store and reload user-defined instrument states (see [Chapter 11.4.2, "How to Save and Recall Instrument Settings"](#), on page 314)

**Mark / Do not mark parameters changed from preset**

To survey the current state of the settings concerning default values, the R&S SMA100B offers a feature that visually identifies deviations from the default values.

For more information, see [Chapter 11.2.2, "How to Identify Parameters Which Are Not in a Preset State"](#), on page 308.

**11.2.1 Preset, Set to Default and Factory Preset Settings**

<a href="#">Preset</a> .....	307
<a href="#">Set To Default</a> .....	307
<a href="#">Preset this Parameter</a> .....	307
<a href="#">Execute Factory Preset</a> .....	308

**Preset**

Resets all parameters and switching states, and closes all opened dialogs.

**Note:**

In contrast to the [Preset] key, the SCPI commands `*RST` and `:SYSTEM:PRESet` do not close open dialogs in the GUI.

Consider also the following possibilities:

- You can define the settings that are restored when you preset the instrument (see [Chapter 11.2.3, "How to Recall User Settings Automatically after Preset"](#), on page 309)
- You can reset the instrument to the factory state (see ["Execute Factory Preset"](#) on page 308)

See also [Table 11-1](#) that contains the key parameters that are reset by the corresponding preset functions.

Remote command:

`*RST` on page 438

**Set To Default**

Resets the associated settings of the corresponding dialog or tab.

**Preset this Parameter**

Restores the default value of a single parameter.

**Execute Factory Preset**

Resets the instrument to its factory settings.

**Note:** "Factory Preset" retains all security settings and does not delete any user files like setups or user data.

See also [Table 11-1](#) that contains the key parameters that are reset by the corresponding preset functions.

Remote command:

:SYSTem:FPReset on page 441

**11.2.2 How to Identify Parameters Which Are Not in a Preset State**

To recognize the current state of the settings related to their default values at the first glance, enable a function that visually identifies parameters in states different than preset.

To activate this display:

1. Open the context-sensitive menu (touch and hold the screen anywhere in the GUI of the R&S SMA100B).
2. Select "Mark all parameters changed from preset".

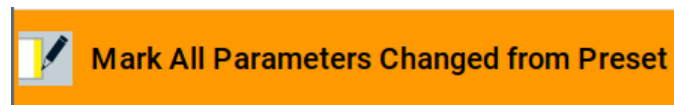

If enabled, the corresponding settings are marked.

**Example:**

Frequency	4.000 000 000 000 GHz	
Offset	10.000 000 kHz	Multiplier 1.000
User Variation		
Variation Active	<input checked="" type="checkbox"/>	Variation Step 1.000 000 000 MHz

**Figure 11-2:** Labeled parameters show that the value deviates from its default

Frequency = changed (default = 1 GHz)  
 Offset = changed (default = 0 kHz)  
 Multiplier = unchanged  
 Variation active = changed (default = disabled)  
 Variation step = unchanged



### 11.2.3 How to Recall User Settings Automatically after Preset

You can define the settings that are restored when you preset the instrument.

1. Configure the settings as required. Save them as described in [Chapter 11.4.2, "How to Save and Recall Instrument Settings"](#), on page 314.
2. Save the settings as a file with the predefined filename `UserPreset.savrc1.txt`. Save this file in the directory `/var/user/`.

The filename `UserPreset.savrc1.txt` and the directory `/var/user/` are mandatory.

Now when you press the [Preset] key or send the `*RST` command to the instrument, the defined settings are restored.

An "Info" message appears and confirms, that a file with user-defined preset setting is loaded.

### 11.2.4 Reference

See [Table 11-1](#) for an overview of the main generator settings that are affected by the corresponding preset functions. While the regular [Preset] key primarily resets the signal relevant parameters of the instrument, the "Factory Preset" affects almost all instrument settings.

For information on the default values of further parameters, refer to the description of the corresponding remote commands.

**Table 11-1: Key parameters affected by preset and factory preset**

Parameter	Preset value	Preset	Factory Preset
RF frequency	1 GHz	x	x
RF level (RF output)	off	x	x
RF OFF mode	-	-	x
Offsets	0	x	x
Modulation state	off	x	x
Uninterrupted level settings	off	x	x
Level attenuator mode	auto	x	x
Level ALC (internal level control)	auto	x	x
Level UCOR (user correction)	off	x	x
LF output state	off	x	x
Sweep state	off	x	x
List mode state	off	x	x
Reference frequency settings (reference oscillator)	-	-	x

Parameter	Preset value	Preset	Factory Preset
Power on settings (Level/EMF)	-	-	x
Network settings	-	-	x
Hostname	-	-	x
GPIB address	-	-	x
Start/Stop display update	-	-	x
Display and keyboard settings	-	-	x
Password and settings protected by passwords (e.g. disabled LAN or USB)	-	-	-
Security settings	-	-	-
User files (setups <sup>2)</sup> , data lists, etc.)	-	-	-

- <sup>2)</sup> `UserPreset.savrcltxt` is renamed as `UserPresetInactive.savrcltxt`; an existing file with the same name is overwritten.



If the default values in the "Remote Access" dialog had been changed, a factory preset via remote control (`:SYSTem:FPReset`) terminates the connection to the instrument. Security settings are never reset.

Resets all parameters and switching states, and closes all opened dialogs.

## 11.3 Protecting Data

During operation, the R&S SMA100B saves user data permanently in the user directory, see "File storage location" on page 303.

**To protect any classified data and to avoid saving any sensitive data on the R&S SMA100B permanently, you have the following options:**

- Activate the **volatile mode**. This mode redirects user data to the volatile memory. The internal memory and the removable memory are write-protected. Instead, you can redirect the user data to an **external storage medium**, as, e.g., a USB stick.  
See also:
  - "Default storage location" on page 303
  - "Volatile Mode" on page 358
  - Chapter 11.9.4, "Using a USB Storage Device for File Transfer", on page 330
- If the R&S SMA100B is equipped with the **removable memory** R&S SMAB-B85 and an SD card is inserted:
  - If the volatile mode is disabled (default setting) the R&S SMA100B **saves user data permanently and only on this storage medium**.

You can access data saved on the removable memory just as data stored in the `/var/user/`.

- If the volatile mode is enabled, the R&S SMA100B redirects user data to the **volatile memory** (SDRAM).  
The data gets lost when you turn off the instrument.
- Save user files **temporarily in the `/var/volatile` directory**, which remains available only until the instrument is turned off.  
You can access data in the volatile memory just as data that is saved permanently in the `/var/user/`.  
See also [Chapter 11.8.3, "How to Display All Saved Files"](#), on page 322.

## 11.4 Saving and Recalling Instrument Settings

Possibly you would like to restore or repeat a signal generation you performed under specific conditions on the instrument. Or, in a test setup with more than one signal generator, you want to transfer the used settings to another R&S SMA100B. In these cases, you can save and recall instrument and user settings, and possibly other related data.

### Save/Recall the complete instrument settings

Two different methods are available for managing *complete instrument settings*:

- Immediate (quick) Save/Recall  
A defined set of instrument settings are saved or recalled quickly in just one step, without defining a filename or storage location. This function enables a fast switching between different instrument settings.
- Save/Recall in files with user-defined names  
The defined set of instrument settings are stored to a definable storage location. The file extension is `*.savrc1.txt`.  
Settings files created in this way are visible in the file system and accessible with the supported methods for file handling.

In the general case, a recall process replaces the instruments settings with the saved values. An exception is the frequency and level settings. During recall of the instrument settings, it is possible to retain the current settings or to overwrite them with the stored values.

### 11.4.1 Save/Recall Settings

#### To access the dialog for storing and loading the complete instrument settings

1. Select "System Config > Save/Recall".
2. Select "Operation Mode > Save or Recall" to access the corresponding settings.

The provided settings for both operations are similar and closely related.

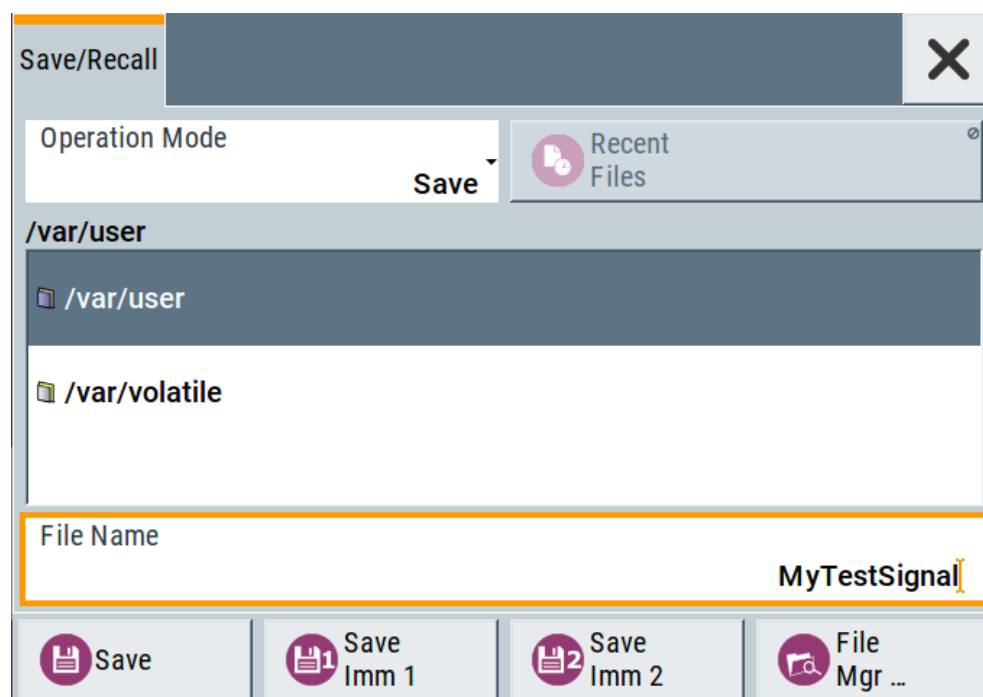
**Settings:**

Operation Mode.....	312
Directory, File List and Filename.....	312
Recent files.....	313
Show SCPI List.....	313
SCPI List.....	313
Save.....	313
Save Immediate x.....	313
Exclude Frequency.....	313
Exclude Level.....	314
Recall.....	314
Recall Immediate x.....	314
File Manager.....	314

**Operation Mode**

Accesses the settings for storing ("Save") and loading ("Recall") of the instrument settings. Also, you can import SCPI-Files ("SCPI-Import") or export SCPI files ("SCPI-Export").

See [Chapter 11.6, "Exporting and Importing Remote Command Lists"](#), on page 317.

**Directory, File List and Filename****Note:**

You access this generic standard function each time you perform one of the following:

- Save or load (settings) files
- Define a folder in that these files are saved
- Navigate through the file system.

The dialog name changes depending on the context. The provided functions are self-explanatory and similar.

Use the settings for example as follows:

- To navigate through the file system, use the directory tree.
- To create a file, load and save files, use the dedicated functions ["New"](#), ["Select"](#), [Save](#), and [Recent files](#).
- To access the general data list editor, use the ["Edit"](#) button (see also [Chapter 7.7, "List Editor"](#), on page 205).
- To perform standard file management functions, like create directories, move, copy, delete files and/or directories, use the standard "File Manager" function (see [Chapter 11.8, "Using the File Manager"](#), on page 318).

Remote command:

To list all files in a directory:

[:MMEMory:CDIRectory](#) on page 447

[:MMEMory:CATalog?](#) on page 446

[\[:SOURce\]:CORRection:CSET:CATalog?](#) on page 621

### Recent files

Displays the files last used.

### Show SCPI List

Opens the "SCPI List", which lists the current settings of the R&S SMA100B as SCPI commands.

The R&S SMA100B provides this function for [Operation Mode > SCPI-Export](#).

### SCPI List

Contains a list of all SCPI commands corresponding to the current instrument settings.

See also ["How to create a SCPI list with the current instrument settings in one step"](#) on page 420

### Save

Saves the current instrument settings under the defined filename.

Remote command:

[:MMEMory:STORe:STATe](#) on page 451

### Save Immediate x

Stores the current instrument setting in one of the intermediate memories.

These instrument settings are retained until a different instrument setting is stored in the intermediate memory. When the instrument is switched off, the contents of the intermediate memories are retained.

Remote command:

[\\*SAV](#) on page 438

### Exclude Frequency

The current frequency is retained when a stored instrument setting is loaded.

Remote command:

[\[:SOURce<hw>\]:FREQuency\[:CW|FIXed\]:RCL](#) on page 627

**Exclude Level**

The current level is retained when a stored instrument setting is loaded.

Remote command:

`[ :SOURce<hw> ] :POWer [ :LEVel ] [ :IMMediate ] :RCL` on page 669

**Recall**

Restores the selected configuration.

During recall, the instrument considers all related settings, for example sweeps in active state or lists. An error message indicates the settings which cannot be implemented.

Remote command:

`:MMEMory:LOAD:STATe` on page 449

**Recall Immediate x**

Loads the selected configuration from one of the intermediate memories. A message appears if no instrument configuration is stored in this memory.

Remote command:

`*RCL` on page 438

**File Manager**

Accesses the "File Manager" dialog, see [Chapter 11.8, "Using the File Manager"](#), on page 318.

## 11.4.2 How to Save and Recall Instrument Settings

Instrument settings can be saved to a file and loaded again later, so that you can repeat the tests with the same settings.

**To access and recall instrument setups quickly**

- ▶ Assign the appropriate action to the [**★** (User)] key.  
See [Chapter 12.2.4, "How to Assign Actions to the \[\*\*★\*\* \(User\)\] Key"](#), on page 348.

**To save and recall instrument settings**

1. Select "System Config > Save/Recall" > "Operation Mode > Save".
2. Select "Save Immediate 1".  
The instrument saves its settings in the intermediate memory 1. The filename and the storage location cannot be changed.
3. Adapt the instrument settings as required. Select "Save Immediate 2"
4. To restore the settings, select the "Operation Mode > Recall"
5. Select "Recall Immediate 1"  
The instrument is restored to the previous state.
6. Select "Recall Immediate 2" to switch to the settings stored in the second file.

**To save complete instrument settings**

1. Select "System Config > Save/Recall" > "Operation Mode > Save".
2. In the file selection dialog, select a filename and storage location for the settings file.
3. Select "Save".

A file with the defined name and path and the extension \*.savrc1.txt is created.

**To restore instrument's configuration**

Save the configuration as described in ["To save complete instrument settings"](#) on page 315.

1. To restore settings, select "System Config > Save/Recall" > "Operation Mode > Recall".
2. To retain the current frequency and level settings, enable "Save/Recall > Exclude Frequency/Level"
3. In the file selection dialog, select the filename and storage location of the settings file.

The settings are restored, but the frequency and level settings are retained; you can repeat the signal generation with the same settings.

See also [Chapter 11.2.3, "How to Recall User Settings Automatically after Preset"](#), on page 309.

## 11.5 Accessing Files with User Data

Signal generation in list mode, the generation of pulse train signals or applying user correction values use data from list files. Whenever a list file is required as a data source, the instrument provides direct access to the standard "File Select" function. This function enables you to select, create and edit the list files.

### 11.5.1 File Select Settings

The "File Select" dialog opens automatically each time the signal generation requires list file as data source.

**To access a loadable data list file**

1. Select ""Sweep" > List Mode Data > List Mode = Data".

A "File Select" dialog for loading, creating and modifying a file is displayed.

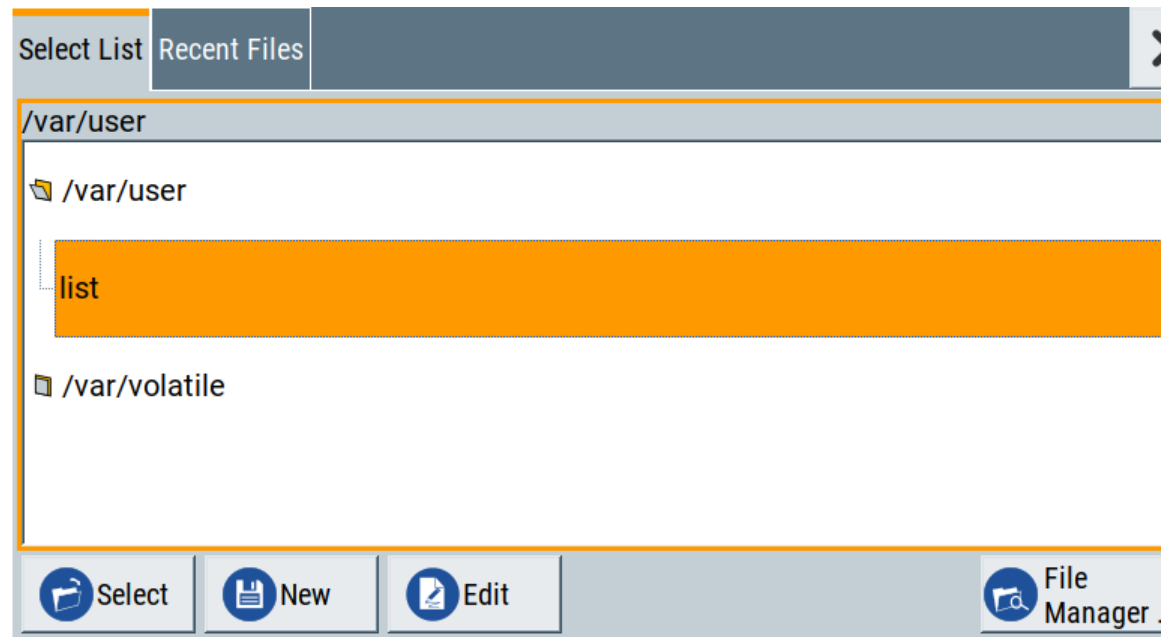

**Tip:** The name of the dialog is context-sensitive and differs depending on the particular function this dialog is from. However, the provided functions are similar.

2. To load an existing file:  
Navigate through the file system.  
Select the file and confirm with "Select".
3. To create a file, for example if there is no data list file specified:  
Navigate through the file system.  
Select "New" and specify the filename.  
A new empty file is created and saved in the selected folder.
4. To edit an existing or newly created file:  
Navigate through the file system.  
Select the file and select "Edit".  
The standard "Data List Editor" dialog opens
5. Edit the file content.  
Confirm with "Save".

#### Settings:

Directory, File List and Filename.....	316
Functions for handling of data lists.....	317
Recent files.....	317
File Manager.....	317

#### Directory, File List and Filename

##### Note:

You access this generic standard function each time you perform one of the following:

- Save or load (settings) files



- Define a folder in that these files are saved
- Navigate through the file system.

The dialog name changes depending on the context. The provided functions are self-explanatory and similar.

Use the settings for example as follows:

- To navigate through the file system, use the directory tree.
- To create a file, load and save files, use the dedicated functions "New", "Select", Save, and Recent files.
- To access the general data list editor, use the "Edit" button (see also [Chapter 7.7, "List Editor"](#), on page 205).
- To perform standard file management functions, like create directories, move, copy, delete files and/or directories, use the standard "File Manager" function (see [Chapter 11.8, "Using the File Manager"](#), on page 318).

Remote command:

To list all files in a directory:

`:MMEMory:CDIRectory` on page 447

`:MMEMory:CATalog?` on page 446

`[ :SOURce ] :CORRection:CSET:CATalog?` on page 621

### Functions for handling of data lists

Provided are the following standard functions for file handling:

"Select"            Select and load the file.

Remote command:

`[ :SOURce<hw> ] :LIST:SElect` on page 655

`[ :SOURce<hw> ] :PULM:TRAI:n:SElect` on page 571

`[ :SOURce<hw> ] :CORRection:CSET [ :SElect ]` on page 620

"New"                Creates file with the specified "Filename".  
To confirm, select "OK"; use "Cancel" to undo the operation.  
To edit the file content, select "File Select > Edit".

"Edit"                Accesses the "Data List Editor" and loads the selected file for editing

### Recent files

Displays the files last used.

### File Manager

Accesses the "File Manager" dialog, see [Chapter 11.8, "Using the File Manager"](#), on page 318.

## 11.6 Exporting and Importing Remote Command Lists

To set specific instrument settings or perform tasks automatically, you can create scripts or import scripts that contain the settings in the form of remote control command sequences.

The R&S SMA100B also offers a SCPI macro recorder with code generator that is used to record manual settings and create an executable script, see [Chapter 13.8.4, "How to Record / Create SCPI Lists"](#), on page 419.

Completed scripts are stored in files and possibly converted to different formats, depending on the used language of the source code.

The R&S SMA100B supports the following commonly used languages:

- Plain SCPI: \*.txt
- MATLAB: \*.m
- NICVI: \*.c
- Python: \*.py

It is also possible to convert the SCPI command list to a user-specific language, see [Chapter 13.8.5, "How to Convert and Save SCPI Lists"](#), on page 422.

## 11.7 Loading, Importing and Exporting Lists

The R&S SMA100B provides built-in editors for creating list files, for example for the list mode or lists with user correction data. You can also create or evaluate them with an external application. The instrument provides interfaces with the following functionality:

- Import and export list files in a standard ASCII format file

Lists are saved and loaded in the corresponding dialogs. For example, the user correction data list is created and stored in the "User Correction" dialog.

## 11.8 Using the File Manager

The "File Manager" is a tool similar to a standard Windows Explorer. It helps you manage mass storage media and files stored on the R&S SMA100B.

You can perform the following tasks:

- Copying multiple files from disk to other media  
See [Chapter 11.9, "How to Transfer Files from and to the Instrument"](#), on page 325
- Copying files into another directory  
See [Cut, Copy&Paste and Delete](#)
- Renaming and deleting files
- Creating directories  
See [Create New Directory](#)
- Mapping shared network folders  
See [Chapter 11.8.4, "How to Map a Network Folder"](#), on page 322
- Displaying saved files  
See [Chapter 11.8.3, "How to Display All Saved Files"](#), on page 322

Access:

- ▶ Select "System Config > Save/Recall" > "File Manager".

**Tip:** Each "Save/Recall" dialog and each "File Select" dialog provides a quick access to the "File Manager", i.e. whenever you select data lists or files with user data.

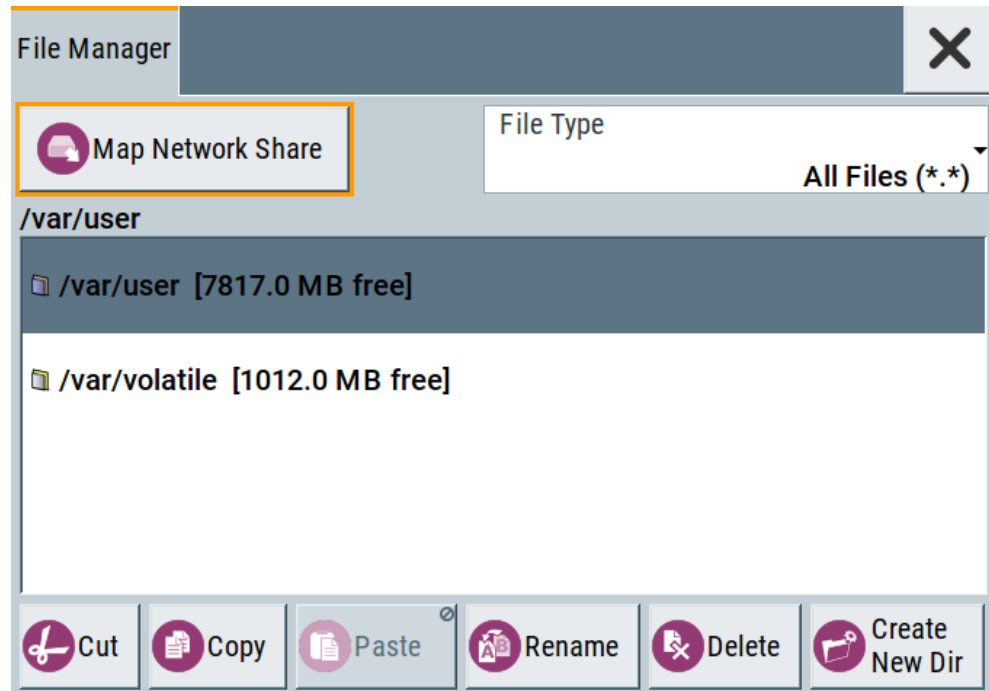

The "File Manager" dialog provides all standard functions required for file management. It displays the contents of the selected folder on the R&S SMA100B and provides functions to rename, delete, copy, or move individual files.

### 11.8.1 File Manager Settings

Access:

- ▶ Select "System Config > Save/Recall" > "File Manager".

**Settings:**

Map Network Share.....	320
File Type.....	320
Directory and Filename.....	320
Cut, Copy&Paste and Delete.....	320
Rename .....	320
Create New Directory.....	320

**Map Network Share**

Accesses the [Map Network Share Settings](#) dialog where you can map one or more network folders.

See also [Chapter 11.8.4, "How to Map a Network Folder"](#), on page 322.

**File Type**

Selects the file type to be listed. If a file type with a specific file extension is selected, only files with this extension are listed.

See [Chapter A.3, "Extensions for User Files"](#), on page 777 for an overview of the supported file extensions.

**Directory and Filename**

Selects the directory in which the file to be deleted or copied is located. The dialog lists all files in this directory. Selected files are highlighted. The path is indicated above the directory tree.

Unlike the "Save/Recall" and "File Select" dialogs, the "File Manager" displays the full filenames including extensions.

Remote command:

[:MMEMory:CDIRectory](#) on page 447

**Cut, Copy&Paste and Delete**

Standard file management functions.

Before a file is deleted, you have to confirm the delete operation.

Remote command:

[:MMEMory:DELeTe](#) on page 449

[:MMEMory:COpy](#) on page 447

**Rename**

Renames the selected file or directory.

Remote command:

[:MMEMory:MOVE](#) on page 450

**Create New Directory**

Creates a folder and opens an edit dialog box to enter name and path (absolute or relative to the current directory) of the new folder.

Remote command:

[:MMEMory:MDIRectory](#) on page 450

## 11.8.2 Map Network Share Settings

Access:

- ▶ Select "System Config > Save/Recall" > "File Manager > Map Network Share".

The "Map Network Share" dialog provides settings that are similar to the standard Windows Explorer function "Map network drive". These settings help you to create up to 10 "shortcuts" to shared folders or computers in the network.

The dialog displays a list of current mapped network folders. The directory tree of the "File Manager", "Save/Recall", and "File Select" dialogs indicate a mapped network folder as /shares/<"Local Folder">.

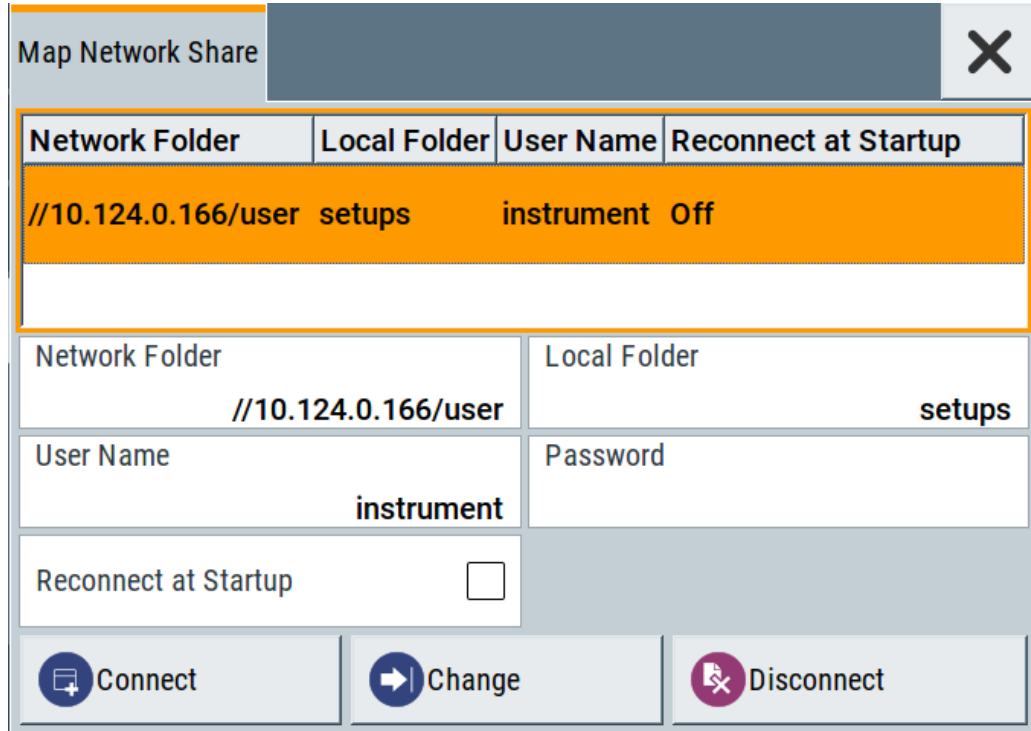

Network Folder	Local Folder	User Name	Reconnect at Startup
//10.124.0.166/user	setups	instrument	Off

Network Folder: //10.124.0.166/user

Local Folder: setups

User Name: instrument

Password: \_\_\_\_\_

Reconnect at Startup:

Buttons: Connect, Change, Disconnect

See also [Chapter 11.8.4, "How to Map a Network Folder"](#), on page 322.

#### Settings:

Network Folder.....	321
Local Folder.....	321
User Name.....	322
Password.....	322
Reconnect at Startup.....	322
Connect.....	322
Change.....	322
Disconnect.....	322

#### Network Folder

Enter the path of the folder or computer, e.g. //<IP Address>/user or //<server name>/user.

#### Local Folder

Enter a letter or an alias name to describe the folder.

In the directory tree, a mapped network folder is indicated as `/shares/`  
<"Local Folder">.

**User Name**

Enter a user name of a user that has the permission to access the selected network folder.

**Password**

Enter the password of the selected user.

**Reconnect at Startup**

Enables reconnecting every time you start up the instrument.

**Connect**

Triggers the instrument to prove the credential and to map (i.e. connect) the selected network folder or computer to the instrument.

You can map up to 10 network folders.

**Change**

Applies the changes.

**Disconnect**

Disconnects the network drive.

### 11.8.3 How to Display All Saved Files

**To display all files on the internal memory**

1. Select "System Config > Save/Recall" > "File Manager".
2. Navigate to `/var/user/`.

**To display all files on a connected USB flash drive**

1. Select "System Config > Save/Recall" > "File Manager".
2. Navigate to `/usb/`.

**To display all files in the volatile memory**

1. Select "System Config > Save/Recall" > "File Manager".
2. Navigate to `/var/volatile/`.

### 11.8.4 How to Map a Network Folder

Possibly you would like to transfer instrument or user settings to another R&S SMA100B, distribute waveform files to several instruments or you have to access

frequently the same network drive. In these cases, on a R&S SMA100B connected to a LAN you can create a shortcut to this network folder or this computer.

How to: see [Chapter 13.6.3, "How To Connect to LAN"](#), on page 400.

To map a network folder, proceed as follows:

1. On the computer or the network folder you want to map, enable remote access. You can specify a list of users allowed for remote access. The remote access settings depend on the operating system the remote computer is using. For step-by-step instructions, refer to the documentation of the particular operating system.
2. On the R&S SMA100B, [enable file transfer via SMB \(samba\)](#).
3. Select "System Config > Setup > Remote Access > Network".  
Select:
  - a) "Address Mode > Auto (DHCP)"
  - b) Check that the "DNS Suffix" and "DNS Server" are correct.
4. In the "Save/Recall" dialog, select "File Manager > Map Network Share".
5. In the "Map Network Share" dialog, select:
  - a) In the "Network Folder" field, enter `//<IP Address>/user` or `//<Server Name>/user`.
  - b) In the "Local Folder" field, enter an alias name, e.g. *setups*.
  - c) Enter the "User Name" and "Password" of a user with a remote access permission to the selected network folder.
  - d) If necessary, enable "Reconnect at Startup".
  - e) Select "Connect".

The selected network folder is mapped to your instrument. The list of mapped network folders is updated.

Map Network Share			
Network Folder	Local Folder	User Name	Reconnect at Startup
//10.124.0.166/user	setups	instrument	Off
Network Folder //10.124.0.166/user		Local Folder setups	
User Name instrument		Password	
Reconnect at Startup		<input type="checkbox"/>	
Connect		Change	
		Disconnect	

- Close the "Map Network Share" dialog.

The navigation tree in the "File Manager" dialog displays the mapped network folder as /shares/Setups.

File Manager	
Map Network Share	File Type List Mode List (*.lsw)
/shares/Setups	
/var/user [7817.0 MB free]	
/shares/Setups [1012.0 MB free]	
/var/volatile [1012.0 MB free]	
Cut	Copy
Paste	Rename
Delete	Create New Dir





If the connection does not succeed, consider to check the following:

- Is the network folder or computer you try to map turned on?
- Is the network folder or computer enabled for remote access?
- Does the selected user name have the necessary permissions?

See also [Chapter 11.9.5, "Using a File Server for Test Files Exchange"](#), on page 330.

## 11.9 How to Transfer Files from and to the Instrument

As explained in ["File handling"](#) on page 304, you access the file system of the R&S SMA100B via one of the following ways:

- Via the built-in "File Manager"  
See [Chapter 11.8, "Using the File Manager"](#), on page 318.
- On an instrument connected to a LAN:
  - Via one of the standard functions ftp or SMB (samba)  
See [Chapter 11.9.2, "Accessing the File System of the R&S SMA100B via ftp"](#), on page 327 and [Chapter 11.9.3, "Accessing the R&S SMA100B File System via SMB \(Samba\)"](#), on page 328
  - Via mapped network drives  
See [Chapter 11.8.4, "How to Map a Network Folder"](#), on page 322.
- Via a connected USB storage device  
See [Chapter 11.9.4, "Using a USB Storage Device for File Transfer"](#), on page 330

Mainly because of security reasons, the access to the file system of your R&S SMA100B can be denied, because one or all these access methods are deliberately disabled. Access to the file system via LAN and/or USB requires that the corresponding service is enabled and a write access to the file system is enabled. Refer to [Chapter 11.9.1, "Removing File System Protection"](#), on page 325 for description of the required steps.

This section provides an introduction to the topic. For comprehensive information, refer to the application note [1GP72: Connectivity of Rohde&Schwarz Signal Generators](#).

- [Removing File System Protection](#)..... 325
- [Accessing the File System of the R&S SMA100B via ftp](#)..... 327
- [Accessing the R&S SMA100B File System via SMB \(Samba\)](#)..... 328
- [Using a USB Storage Device for File Transfer](#)..... 330
- [Using a File Server for Test Files Exchange](#)..... 330

### 11.9.1 Removing File System Protection

Before you try to access the file system via ftp, SMB (samba) or USB, fulfill the following:

- Disable write protection on the file system

- Enable the corresponding service or interface

**To enable write permission on the file system**

1. Select "System Config > Setup > Security > Security > General"
2. Enable "Volatile Mode"
3. Enter the "Security Password".  
The default password is 123456. For more information, see [Chapter 12.4, "Using the Security Settings"](#), on page 353.
4. Select "System Config > Setup > Maintenance > Shut Down"
5. Select "Reboot".  
The system reboots. The enabled settings are active.

**To enable file transfer via ftp**

1. Select "System Config > Setup > Security > Security > LAN Services".
2. Enable "LAN Interface"
3. Enable "FTP"
4. Enter the "Security Password".  
The default password is 123456. For more information, refer to [Chapter 12.4, "Using the Security Settings"](#), on page 353.
5. Select "Accept".

**To enable file transfer via SMB (samba)**

1. Select "System Config > Setup > Security > Security > LAN Services"
2. Enable "LAN Interface"
3. Enable "SMB (Samba)"
4. Enter the "Security Password".  
The default password is 123456. For more information, refer to [Chapter 12.4, "Using the Security Settings"](#), on page 353.
5. Select "Accept".

**To enable file transfer via USB**

1. Select "System Config > Setup > Security > Security > General"
2. Enable "USB Storage"
3. Enter the "Security Password".  
The default password is 123456. For more information, refer to [Chapter 12.4, "Using the Security Settings"](#), on page 353.
4. Select "Accept".

## 11.9.2 Accessing the File System of the R&S SMA100B via ftp

If the R&S SMA100B is connected to a LAN, you can use file transfer protocol (ftp) to access the file system and to transfer files from and to the instrument.

How to: see [Chapter 13.6.3, "How To Connect to LAN"](#), on page 400.

### To access the file system via ftp

We assume that the instrument and the remote PC are connected to a LAN.

1. [Enable file transfer via ftp](#)
2. [Enable write permission on the file system](#)
3. On the remote PC, start the Windows Explorer.
4. In the address field, enter `ftp://<"IP Address" of the Instrument>`, e.g. `ftp://10.124.0.166`.

**Tip:** The R&S SMA100B indicates its IP address on the home screen.

A log-on dialog opens and requests a password.

The default user name and password is *instrument*.

#### Tip:

#### Default password

The FTP and SAMBA file access use the user "instrument" with default password "instrument".

We recommend that you change this password in the "Setup > Security > Password Management > Change User Password" dialog before connecting the instrument to the network.

See [Chapter 12.4.4, "Password Management"](#), on page 363.

5. Enter the password to access the `user` directory.  
The `user` directory corresponds to the `/var/user/` directory of the instrument.

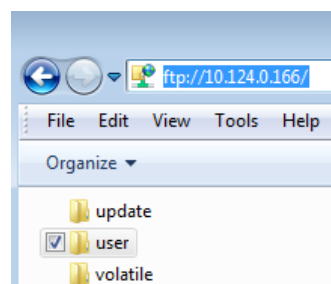

There, you can perform standard functions like creating directory, or saving files.

6. In the `user` directory, create a directory, e.g. `test ftp`.
7. Select "System Config > Save/Recall".  
Open the `/var/user/` directory.

The dialog displays the `/var/user/test ftp` directory.

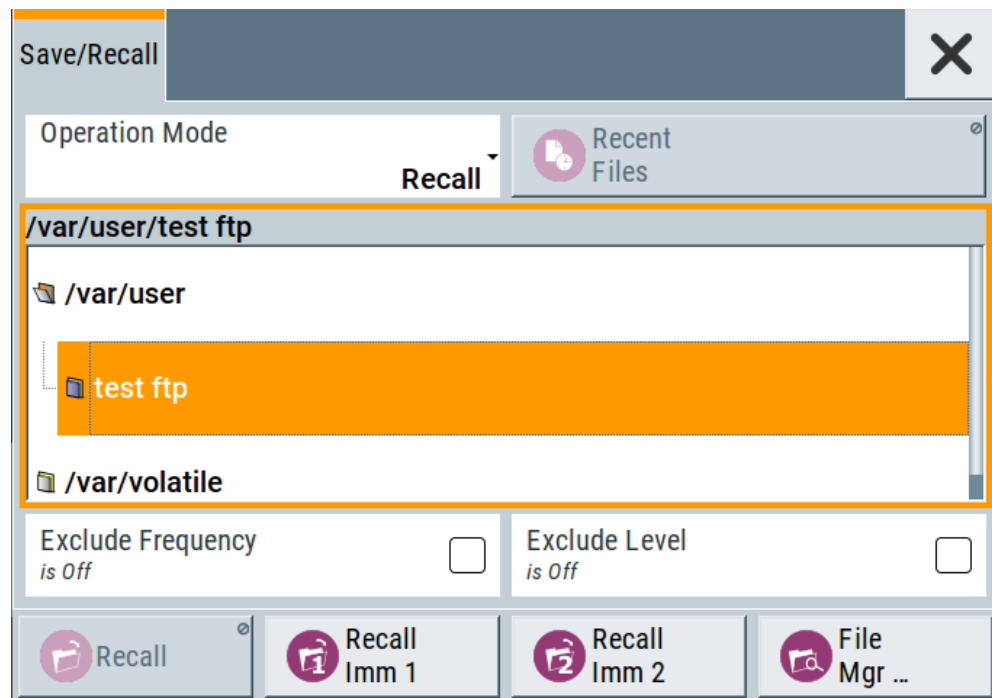

### 11.9.3 Accessing the R&S SMA100B File System via SMB (Samba)

The SMB (Samba) protocol is an alternative way to access the file system of the instrument from a remote PC. This protocol works if both the instrument and the PC are connected to a LAN.

How to: see [Chapter 13.6.3, "How To Connect to LAN"](#), on page 400.

#### To access the file system via SMB

We assume that the instrument and the remote PC are connected to a LAN.

1. [Enable file transfer via ftp](#)
2. [Enable write permission on the file system](#)
3. On the remote PC, start the Windows Explorer.
4. In the address field, enter `///"IP Address" of the Instrument>, e.g. ftp://10.124.0.166.`

**Tip:** The R&S SMA100B indicates its IP address on the home screen.

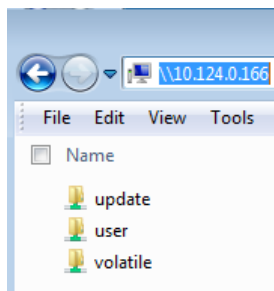

The `user` directory corresponds to the `/var/user/` directory of the instrument; the `volatile` directory - to the `/var/volatile` directory.

### To map the R&S SMA100B as a network drive to the remote PC

We assume that the instrument and the remote PC are connected to a LAN.

1. [Enable file transfer via SMB \(Samba\)](#)
2. [Enable write permission on the file system](#)
3. On the remote PC, start the Windows Explorer. Open the "Map Network Drive" dialog.
  - a) Select a valid "Drive", e.g. *W*.
  - b) In the "Folder" field, enter `//<"IP Address" of the Instrument>/user` or `//<"Hostname" of the Instrument>/user`  
For example: `//10.124.0.166/user` or `//SMA100B-102030/user`.  
**Tip:** The R&S SMA100B indicates its IP address on the screen.
  - c) Select "Finish".

A log-on dialog opens and requests a user name and a password.

The default user name and password is *instrument*.

#### Tip:

##### Default password

The FTP and SAMBA file access use the user "instrument" with default password "instrument".

We recommend that you change this password in the "Setup > Security > Password Management > Change User Password" dialog before connecting the instrument to the network.

See [Chapter 12.4.4, "Password Management"](#), on page 363.

4. Enter the user name and the password of your instrument.

The `/var/user/` directory of the instrument is mapped to and displayed as a network drive of the remote PC.

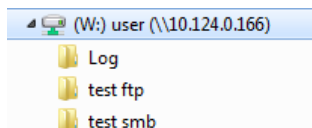

You can access the files in the `/var/user/` directory, perform standard function like creating directory, or storing files.

#### 11.9.4 Using a USB Storage Device for File Transfer

Alternatively to the file transfer possibility via LAN, you can use a USB storage device for direct file transfer from and to the instrument.

We recommend that you transfer files with user data (like lists or instrument setup files) to the instrument, rather than load and play them from a connected USB storage device.

##### To transfer a file with user data to the instrument

1. Connect a USB storage device, for example a USB memory stick to one of the USB interfaces of the instrument.  
The R&S SMA100B recognizes the connected USB storage device automatically.
2. [Enable file transfer via USB](#)
3. [Enable write permission on the file system](#)
4. Select "System Config > Save/Recall".  
The dialog displays the `/var/user/` directory and the `/usb/` drive.
5. In the "Save/Recall" dialog, select "File Manager".
6. In the directory tree, navigate to the `/usb/` drive.  
Select the required file with user data.
7. Select "Copy".
8. In the directory tree, navigate to the `/var/user/` directory.  
Select "Paste".  
The file with user data is transferred to the instrument.

#### 11.9.5 Using a File Server for Test Files Exchange

You can use a central file storage location like a file server in your company network to store setup files, SCPI scripts, application programs, or waveform files on it. Usually, you would like to distribute the files to several instruments. If the R&S SMA100Bs are connected to a LAN, you can create a shortcut on the instruments to the file server.

##### To access the file server

1. On each R&S SMA100B, map the required directory of the file server to the instrument.  
Perform the steps described in [Chapter 11.8.4, "How to Map a Network Folder"](#), on page 322.

- On each R&S SMA100B, use the same alias name for the directory of the file server, i.e. enter the same "Local Folder" (in this example *Setups*).

On any of the R&S SMA100B, you access the file server directly from the "File Manager" and under the same name, e.g. `/shares/Setups`.

An extra advantage in remote control is that the same application program would control the instruments.

For example, use the remote control command `MMEemory:CDIRectory "/shares/Setups"` to set the default directory for mass storage.

## 11.10 Creating Screenshots of Current Settings

The save/recall function enables you to save current settings in a file. To document the most important settings for a performed signal generation, you can also save a hardcopy of the current display.

- [Hardcopy Settings](#).....331
- [How to Save a Hardcopy of the Display](#).....335

### 11.10.1 Hardcopy Settings

Access:

- ▶ Select "System Config > Setup > User Interface > Hardcopy".

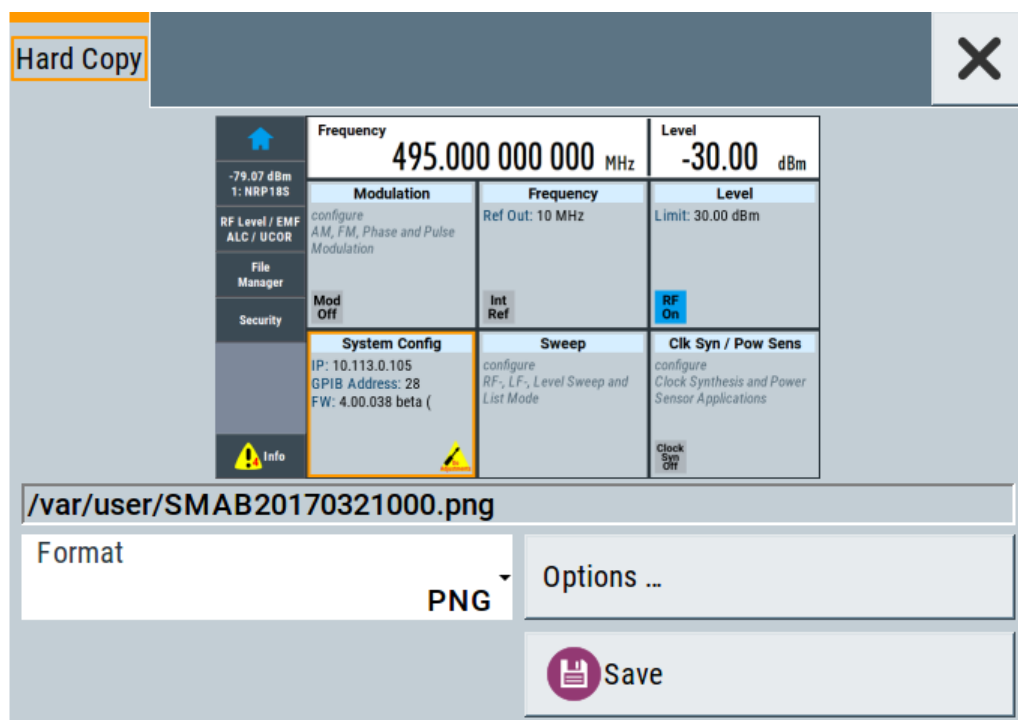

The remote commands required to define these settings are described in [Chapter 14.11, "HCOPY Subsystem"](#), on page 468.

### Settings:

File.....	332
Format.....	332
Options.....	332
Save.....	332
Hardcopy Options > Common.....	332
L Automatic Naming.....	333
L Format.....	333
L Region.....	333
Hardcopy Options > Automatic Naming.....	333
L Path.....	334
L Clear Path.....	334
L Prefix, Year, Month, Day.....	334
L Current Auto Number.....	334

### File...

In "Automatic Naming > Off" mode, accesses the standard file select dialog for selecting the filename and folder the hardcopy is stored in.

If you have enabled "Automatic Naming", the instrument displays the automatically generated filename.

Remote command:

`:HCOPY:FILE[:NAME]` on page 470

### Format

Selects the output file format, for example \*.bmp, \*.jpg\*.xpm and \*.png.

Remote command:

`:HCOPY:IMAGe:FORMat` on page 470

`:HCOPY:DEVIce:LANGUage` on page 470

### Options...

Accesses [Hardcopy Options](#) dialog.

### Save

Saves a hardcopy of the current display as a file.

Remote command:

`:HCOPY[:EXECute]` on page 471

### Hardcopy Options > Common

Access: select "Hardcopy > Options... > Common".

With the provided settings, you can customize the file format and the syntax of the automatically assigned filename.



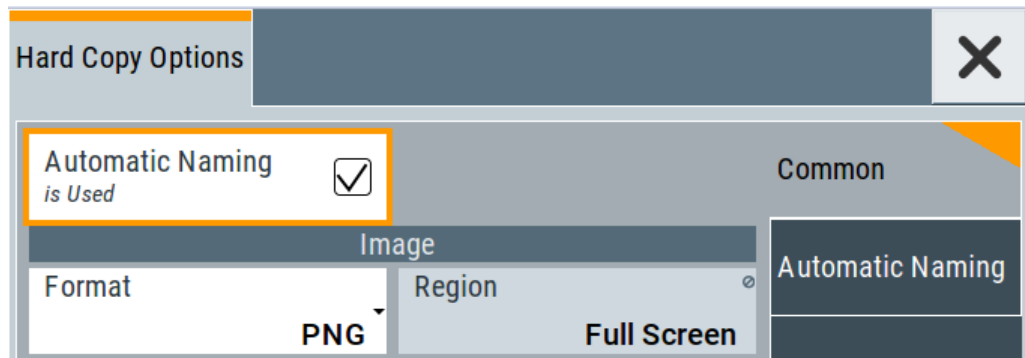

#### Automatic Naming ← Hardcopy Options > Common

If enabled, creates the output filenames automatically according to the rules set with the [Hardcopy Options > Automatic Naming](#) settings.

Remote command:

[:HCOPY:FILE\[:NAME\]:AUTO:STATE](#) on page 472

#### Format ← Hardcopy Options > Common

Selects the output file format, for example \*.bmp, \*.jpg\*.xpm and \*.png.

Remote command:

[:HCOPY:IMAGE:FORMAT](#) on page 470

[:HCOPY:DEVICE:LANGUAGE](#) on page 470

#### Region ← Hardcopy Options > Common

Displays the snapshot area.

Remote command:

[:HCOPY:REGION](#) on page 470

#### Hardcopy Options > Automatic Naming

Access: select "Hardcopy > Options... > Automatic Naming".

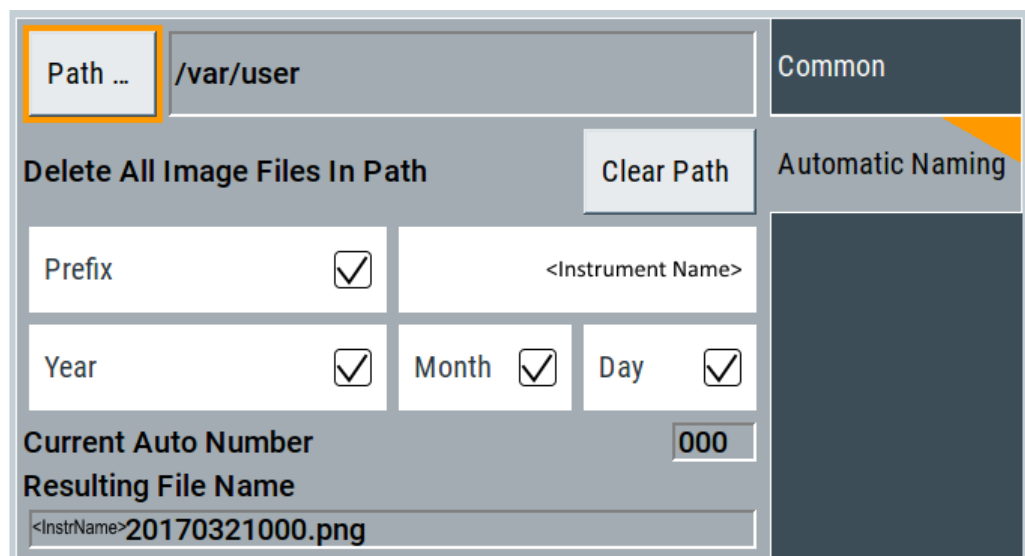

Provided are the following settings:

#### **Path... ← Hardcopy Options > Automatic Naming**

Selects the directory.

**Note:** To select the destination path, specify also a filename. Otherwise an error message is displayed and selection is canceled.

Remote command:

`:HCOPY:FILE[:NAME]:AUTO:DIRectory` on page 471

#### **Clear Path ← Hardcopy Options > Automatic Naming**

Deletes all image files with extensions \*.bmp, \*.jpg, \*.png and \*.xmp in the directory set for automatic naming.

Before the command is executed, a warning message prompts you to confirm the deletion of the files.

Remote command:

`:HCOPY:FILE[:NAME]:AUTO:DIRectory:CLEar` on page 472

#### **Prefix, Year, Month, Day ← Hardcopy Options > Automatic Naming**

Determines the rules for "Automatic Naming".

Per default, the automatically generated filename is composed of:

`<Path>/<Prefix><YYYY><MM><DD><Number>.<Format>`, where Y, M and D mean year, month, Day; Number is the [Current Auto Number](#).

You can activate or deactivate each component separately.

The "Resulting filename" indicates the current filename syntax.

Remote command:

`:HCOPY:FILE[:NAME]:AUTO[:FILE]:PREFix` on page 473

`:HCOPY:FILE[:NAME]:AUTO[:FILE]:PREFix:STATe` on page 473

`:HCOPY:FILE[:NAME]:AUTO[:FILE]:YEAR:STATe` on page 472

`:HCOPY:FILE[:NAME]:AUTO[:FILE]:MONTH:STATe` on page 472

`:HCOPY:FILE[:NAME]:AUTO[:FILE]:DAY:STATe` on page 472

#### **Current Auto Number ← Hardcopy Options > Automatic Naming**

Indicates the number which is used in the automatically generated filename.

**Note:** When initially switching on the instrument, the number is reset to the lowest possible value. Starting with number 0 the output directory is scanned for existing files. As long as files with the same name are existing, the number is increased by 1. The number is automatically set so that the resulting filename is unique within the selected path. The current number is not in the save/recall file but is temporarily stored within the database. At the following save operation, the number is increased.

Remote command:

`:HCOPY:FILE[:NAME]:AUTO[:FILE]:NUMBer?` on page 473

## 11.10.2 How to Save a Hardcopy of the Display

1. Select "System Config > Setup > User Interface > Hardcopy".

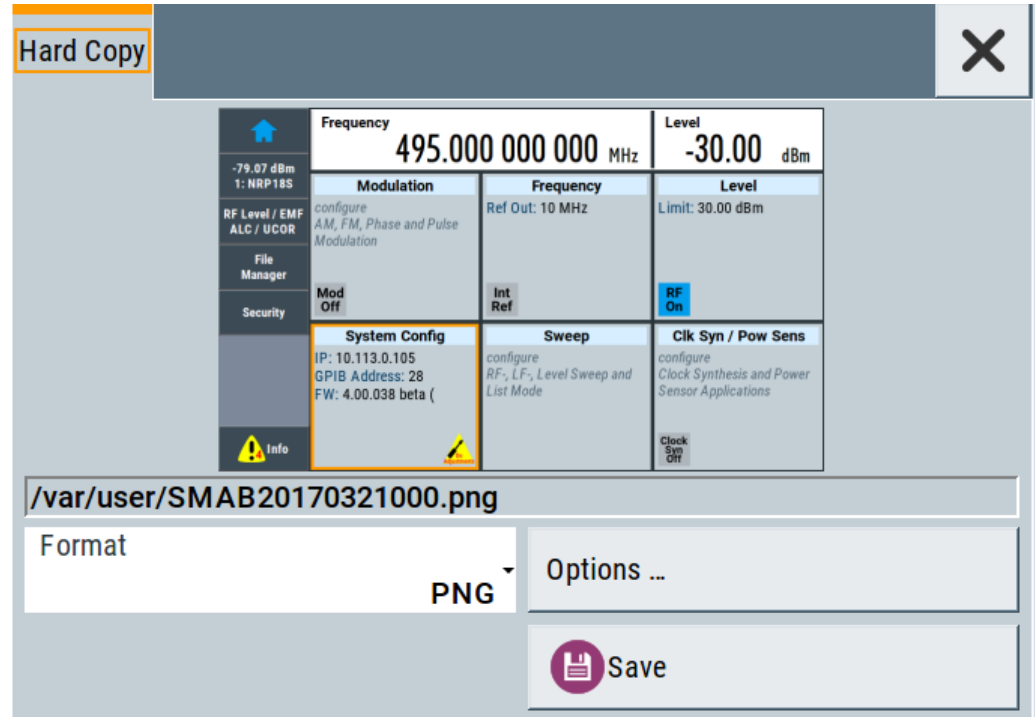

2. To define the output format, select "Format > JPG".
3. To enable the instrument to create output filenames, select "Automatic Naming > On".
4. Select "Options...".
5. In the "Hardcopy Options" dialog:
  - a) To change the default directory the file is saved in, select "Automatic Naming Settings > Path" and define a path and a filename. For example, select the default directory `/var/user`.
  - b) If necessary, disable or change some of the parameters in the "Automatic Naming Settings".
  - c) Close the "Hardcopy Options" dialog.
6. In the "Hardcopy" dialog, select "Save".  
The instrument saves a hardcopy of the current instrument display as a `*.jpg` file. The filename is automatically created.
7. To print the hardcopy, connect the instrument to a LAN and:
  - a) Transfer the file to a remote computer as described in [Chapter 11.9, "How to Transfer Files from and to the Instrument"](#), on page 325.
  - b) On the remote computer, navigate through the file system.

- c) Print the selected file.  
For more information, refer to the online help of the operating system.

## 12 General Instrument Functions

The general instrument functions include basic instrument settings, regardless of the selected operating mode and measurement. Some of these settings like screen display and peripherals are initially configured at the setup of the instrument, according to personal preferences and requirements. However, you can individually adjust the settings at any time, for example, if necessary for specific applications.

The following special functions help you in service and basic system configuration:

- [Chapter 12.1, "Customizing the User Interface"](#), on page 337  
Allows you to adjust the display and keyboard language settings.
- [Chapter 12.2, "Organizing Frequently Used Settings as Favorites"](#), on page 342  
Enables you to group user defined settings in a favorites list or to assign actions to the [★ (User)] as quick access for later retrieval.
- [Chapter 12.3, "Managing Licenses and License Keys"](#), on page 349  
If you have purchased an additional option for the R&S SMA100B, you can enable it using a license key.
- [Chapter 11.2, "Restoring the \(Default\) Instrument Configuration"](#), on page 305  
At any time, you can restore a default configuration to start a measurement at a defined instrument state, or set the instrument to factory preset.
- [Chapter 17.3, "Performing Maintenance Tasks"](#), on page 739  
Special functions like calibration routines and self-tests put your instrument to an initial state.
- [Chapter 12.4, "Using the Security Settings"](#), on page 353  
Special security and protection functions protect your instrument from unauthorized use or activate specific test routines.

### 12.1 Customizing the User Interface

The R&S SMA100B provides basic alignments of instrument settings regarding the user interface, that means the touch panel (screen), the appearance of the displayed dialogs and graphics, and an external keyboard.

#### Start / stop display update

The operating system of the R&S SMA100B refreshes the displayed settings by default in almost real-time, to keep the display updated with the internally used values. However, you can turn off this function to reduce settling times when the instrument is remote controlled.



We recommend that you switch off the display update for optimum sweep performance with short dwell times and for fast settling times.

Consider that in this case the displayed values can differ from the operated values.

In detail described in the following paragraphs, you can:

- Set display and keyboard language, see [Chapter 12.1.1, "Display and Keyboard Settings"](#), on page 338
- Set date and time for the system clock, see [Chapter 17.3.1, "Date and Time"](#), on page 739
- Configure and activate a [Screen Saver](#)
- Deactivate display update to improve performance, see [Chapter 12.1.2, "Display Update Settings"](#), on page 339
- Determine the state of the RF signal, and the level display in the status bar when you turn on the R&S SMA100B, see [Chapter 12.1.3, "Defining the RF Signal State On Power On"](#), on page 340.

## 12.1.1 Display and Keyboard Settings

Access:

1. Select "System Config > Setup > User Interface > Display/Keyboard > Display".

Display	USB Keyboard	
Screen Saver <i>is Active</i>	<input checked="" type="checkbox"/>	Wait time <b>10 Min</b>
Brightness		
Display <b>14</b>		RF Hardkey <b>14</b>

2. Select "Display/Keyboard > USB Keyboard".

Display	USB Keyboard	
Layout		English (US)

In the "Display/Keyboard" dialog, you can change regional and language options for the GUI and an external keyboard, and define the screen saver settings.

The remote commands required to configure the display and keyboard are described in [Chapter 14.9, "DISPlay Subsystem"](#), on page 462 and [Chapter 14.12, "KBOard Subsystem"](#), on page 473.

<a href="#">Screen Saver</a> .....	339
<a href="#">Wait Time</a> .....	339
<a href="#">Display</a> .....	339
<a href="#">RF Hardkey</a> .....	339
<a href="#">USB Keyboard &gt; Layout</a> .....	339

**Screen Saver**

Activates the screensaver.

If activated, the display including backlight is switched off after the selected **Wait Time** elapses and if no entries via touch panel, front panel, external mouse, or external keyboard are made

Remote command:

`:DISPlay:PSAVe[:STATe]` on page 464

**Wait Time**

Enters the idle time that must elapse before the display lamp is shut off when no entries are made.

Remote command:

`:DISPlay:PSAVe:HOLDoff` on page 463

**Display**

Adjusts the brightness of the display.

Increase the value to turn up the display brightness.

Remote command:

`:DISPlay:BRIGhtness` on page 464

**RF Hardkey**

Adjusts the brightness of the [RF on/off] key.

Increase the value to change the contrast between the key and the front panel background color.

Remote command:

`:DISPlay:BUtTon:BRIGhtness` on page 464

**USB Keyboard > Layout**

Selects the language of an externally connected keyboard via USB. The function assigns the corresponding keys automatically.

Remote command:

`:KBOard:LAYout` on page 474

## 12.1.2 Display Update Settings

Access:

- ▶ Select "System Config > Setup > User Interface > Start/Stop Display Update".

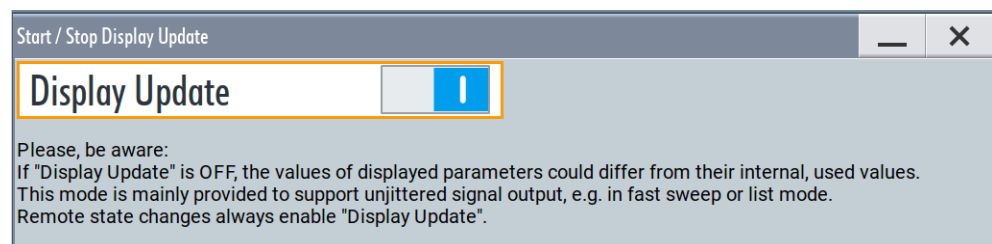

This dialog enables you, to deactivate updating the display.

The remote command to switch off the display update is described in [Chapter 14.9, "DISPlay Subsystem"](#), on page 462.

#### Display Update is

Disables the automatic refreshing of the displayed values.

Remote command:

:DISPlay:UPDate on page 464

### 12.1.3 Defining the RF Signal State On Power On

As additional functions for the level settings, you can determine the state of the RF signal, and the level display in the status bar when you turn on the R&S SMA100B.

#### Power-On/EMF settings

Access:

- ▶ Select "Level" > "Power-On / EMF".

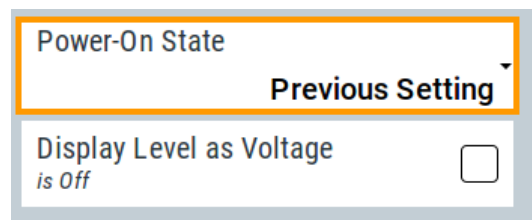

The "Power-On/EMF" dialog contains all settings for configuring the power-on behavior and the level display.

#### Settings:

<a href="#">Power-On State</a> .....	340
<a href="#">Display Level as Voltage of EMF</a> .....	340

#### Power-On State

Determines the RF signal output state when the instrument is switched on.

You can disable the RF output signal in general, or start it in the same state as it had been when it was switched off.

Remote command:

:OUTPut<hw>[:STATe]:PON on page 475

#### Display Level as Voltage of EMF

Activates display of the signal level as voltage of the EMF (no-load voltage).

If disabled, the level is displayed as a voltage over a 50 Ohm load.

**Note:**



The setting is not affected by an instrument preset ([Preset] key or \*RST) and the "Save/Recall" function. It is reset only by factory preset.

Remote command:

[ :SOURce<hw> ] :POWer:EMF:STATe on page 664

## 12.1.4 How to Set the Initial Instrument Settings

This section describes how to set up the R&S SMA100B initially.

### 12.1.4.1 Setting the Keyboard Language

You can select the language of the external keyboard connected to the instrument.

#### To adjust the keyboard settings

1. Press the [Setup] key.
2. Select "User Interface > Keyboard".

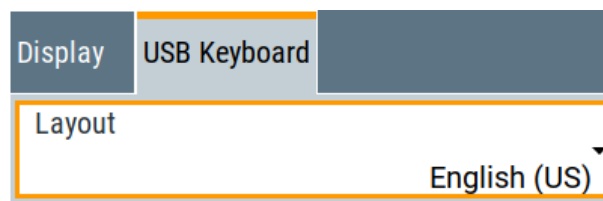

3. Select the "Layout".

The dialog closes and the changes take effect immediately.

### 12.1.4.2 Setting the Screen Saver

You can enable a screen saver that automatically turns off the display after a user-defined period of time. The screen saver is activated if no settings are made on the touch screen, or via keys or the rotary knob during the selected wait time.

#### To activate the screen saver

1. Press the [Setup] key.
2. Select "User Interface > Display"
3. Activate the "Screen Saver".

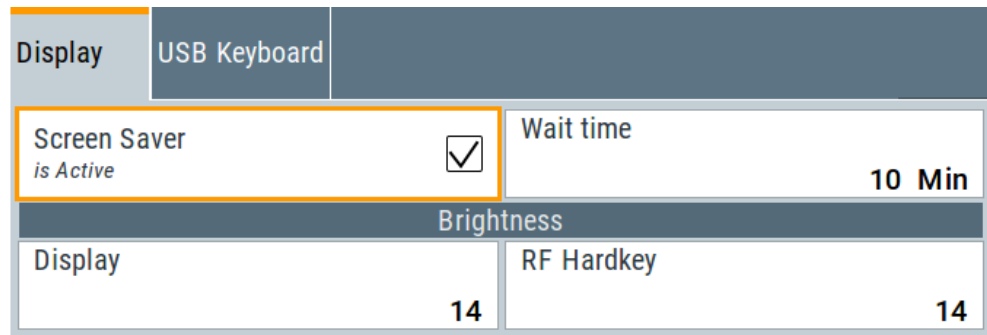

4. Define the "Wait Time" in minutes.  
The instrument turns off the display after the defined period of time.
5. To reactivate the display, tap the screen or press any key on the front panel.

#### To deactivate the screen saver

1. Press the [Setup] key.
2. Select "User Interface > Display"
3. Disable the "Screen Saver" state.

## 12.2 Organizing Frequently Used Settings as Favorites

The R&S SMA100B provides two possibilities to define frequently used settings and procedures for later retrieval individually.

#### User menu and [★ (User)] key

These two functions work similar to the favorites function of a browser or other programs. They allow you to create a list of frequently used actions or to group frequently used settings in one dialog.

You can collect the parameters of your configuration in a favorites list, i.e. in the "User Menu", or define settings and actions with the [★ (User)] key:

- "User Menu" to group settings of specific tasks.  
Similar to a favorites function, you can use this menu for:
  - Grouping the settings required for a task in one dialog.
  - Saving and recalling the settings of a task.
  - Transferring the settings for use on multiple instruments.
- [★ (User)] key, with customizable function.  
You can perform the following steps using this key:
  - Open the "User Menu" (default functionality).
  - Add or remove settings and functions.
  - Execute actions and access functions.

### Possible applications

The ★ (User) key and the "User Menu" are useful for the following situations:

- There are functions or tasks you have to perform in a defined order but the setting parameters are distributed across several dialogs.
- There are functions or tasks you have to perform frequently but they are not accessible via the front panel keys.
- The required functions are grouped in a dialog that is not directly accessible from the home screen.
- Your task involves the frequently loading and executing of certain SCPI scripts. Refer to [Chapter 13.8.4, "How to Record / Create SCPI Lists"](#), on page 419 for information on how to create an SCPI script.
- A quick access to saved setups is required.
- There are functions and tasks you have to perform on several instruments.

### Dialog identification

To identify each dialog, the instrument uses a dedicated dialog ID. The dialog ID contains the dialog position on the display and the current active tab. The action that triggers the instrument to open a dialog uses this identification.

### Save/Recall vs. recall setup

If you need to restore a specific signal generation setup and perform further configurations based on this particular instrument state, the R&S SMA100B provides two options:

- "Save/Recall" function  
For a detailed description, refer to [Chapter 11.4, "Saving and Recalling Instrument Settings"](#), on page 311.
- "Recall Setup" function  
If the "Recall Setup" is the only user action assigned to the [★ (User)] key, pressing this key triggers the R&S SMA100B to load the user-defined preset file immediately.

## 12.2.1 User Menu Settings

The "User Menu" dialog contains function keys to organize, save and load a favorites list. You can also modify, add or delete list entries directly in the dialog.

### Clear User Menu

Removes all entries from the "User Menu" at once.

### Save User Menu

Saves the current "User Menu" under the defined filename.

### Recall User Menu

Loads the selected "User Menu" file.

This function enables you to use the user specific favorites file on another instrument. However, if functions or parameters are not provided due to varying configuration of the instrument, the settings of these particular parameters take no effect.

## 12.2.2 How To Use the User Menu for Fast Adjustments

Access:



1. Press the [★ (User)] key.

The "User Menu" dialog opens.

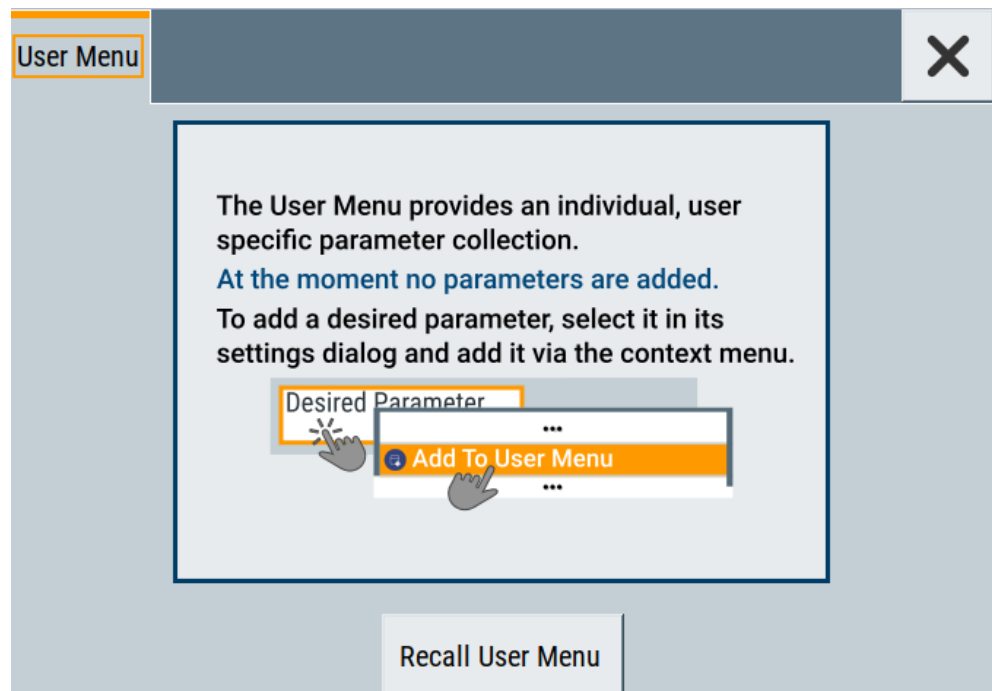

If you execute this action for the first time, the dialog displays instructions on how to use the "User Menu".

2. If you already have a saved user menu file on the instrument, you can load with "Recall User Menu".

### Creating a "User Menu"

To create your own user dialog with settings:

1. Open a dialog with settings you frequently use.
2. Select a parameter.
3. Open the context menu and select "Add to User Menu".

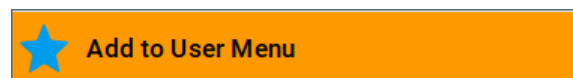



A favorites icon ★ indicates that the parameter is used in the "User Menu".

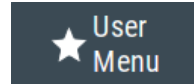

The "User Menu" button in the taskbar confirms that you have created a "User Menu" with at least one entry.

4. Press the [★ (User)] key.

The "User Menu" dialog shows all parameters that you have added to the list.

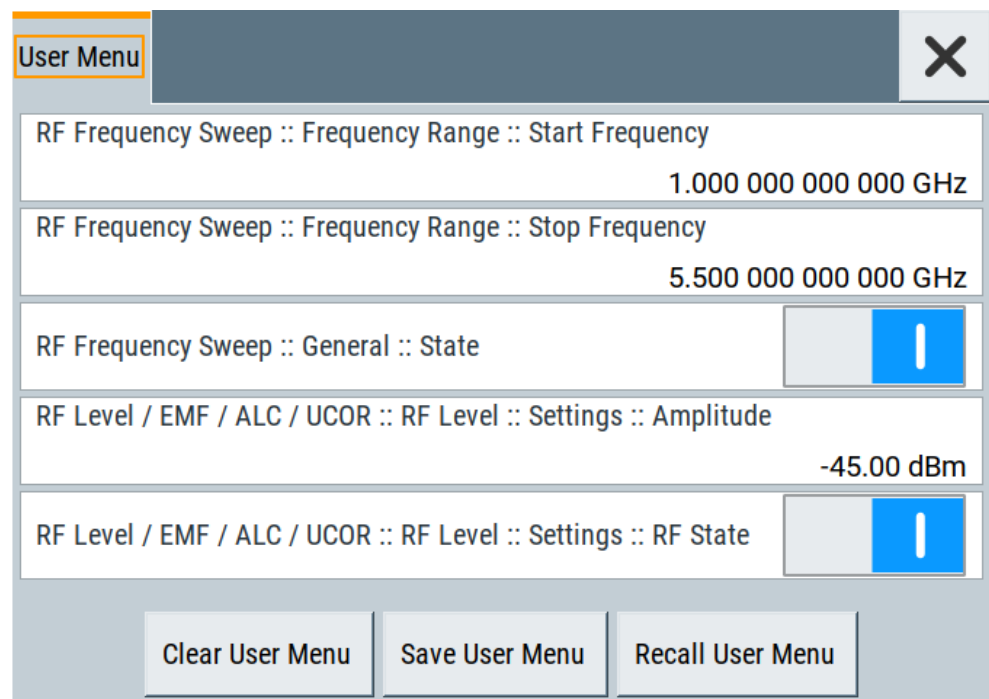

You can modify the parameter settings directly in this dialog, e.g. change a state or set values, as you do in the particular dialog the parameter originally belongs to.

5. To remove an entry, select the parameter either in the "User Menu" or in the dialog where it originally belongs to.
  - a) Open the context menu and select "Remove from User Menu".



6. To remove all entries at once, select "Clear User Menu".
7. To save your individual favorites list, select "Save User Menu", and follow the file managing instructions.

The file system automatically assigns the file extension \*.user\_menu.

- To recall a previously saved user menu, select "Recall User Menu" and proceed accordingly.

### Providing a user menu favorites list for several instruments

To transfer files from or to an instrument:

- Create the favorites list, as described in "Creating a "User Menu"" on page 344.
- Save the favorites list.
- To transfer a file from or to an instrument, the R&S SMA100B provides several options, see "File handling" on page 304.

## 12.2.3 Define User Key Actions Settings

Access:

- ▶ Select "System Configuration > Setup > User Interface > Define User Key".

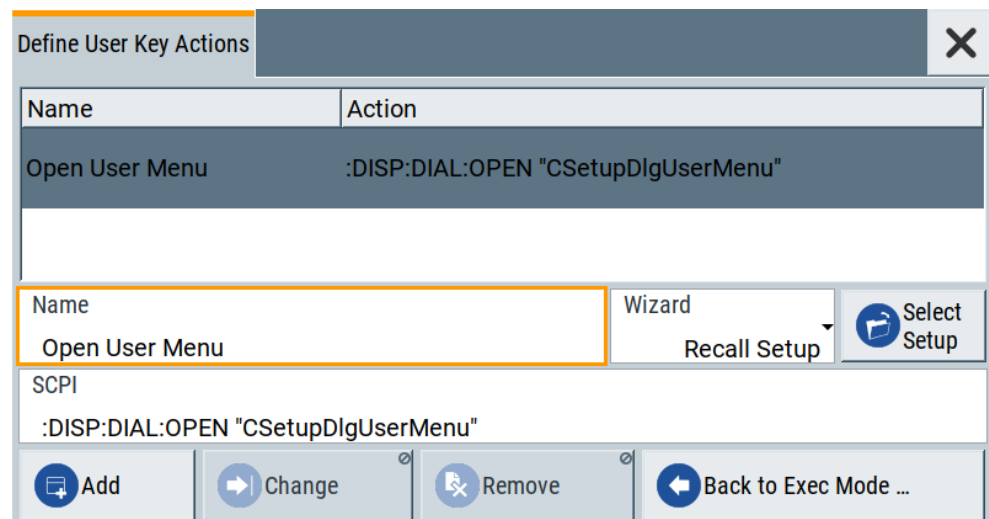

The dialog displays a list of the currently enabled actions and provides functions to define new, edit or remove existing actions. If no actions have been defined, the list is empty.

See [Chapter 12.2.4, "How to Assign Actions to the \[★ \(User\)\] Key"](#), on page 348.

The remote commands required to define these settings are described in [Chapter 14.9, "DISPlay Subsystem"](#), on page 462.

#### Name

Enters a user-defined name for the action.

#### Wizard

Defines the action to be executed.

**"Load SCPI Script"**

Selecting the action load and executes the SCPI script.

**"Recall Setup"** Load a setup for quick access to the user-defined settings.

**"Open Dialog"**

Quick access to the selected dialog.

**Select**

Depending on the selected "Wizard", provides access to:

- The standard "File Select" function for loading of an SCPI script or setup file
- A list of the dialog IDs of all currently opened dialogs. The dialog ID is used for dialog identification in the remote control.

See [SCPI](#).

**SCPI**

For the currently selected action, displays the corresponding SCPI command with the associated parameter for dialog identification (dialog ID). The automatically displayed SCPIs are enabled for subsequent modification.

Remote command:

[:DISPlay:DIALog:OPEN](#) on page 466

See also [:DISPlay:DIALog:ID?](#) on page 465

**Add, Change, Remove**

Standard functions for managing of the actions.

**Back to Execute Mode**

Opens the "Select Action to Execute" dialog. Select an Action form the list to execute it.

To return to the "Define User Key Actions" dialogs, select [Select Action to Execute > Define Actions](#).

**Select Action to Execute > Define Actions**

Name	Action
Open User Menu	:DISP:DIAL:OPEN "CSetupDlgUserMenu"
Open	:DISP:DIAL:OPEN "CSetupFrontPanelKe...

 Define Actions ...

Accesses the "Define User Key Actions" dialog.

### 12.2.4 How to Assign Actions to the [★ (User)] Key

The customizable [★ (User)] key has no predefined function assigned. You can individually define actions to be executed or functions to be accessed when pressing this key.

To assign a frequently used dialog to the [★ (User)] key:

1. Open the dialog you want to quickly access.  
For example, select "Level > UCOR > Import/Export"
2. Select "System Configuration > Setup > User Interface > Define User Key".
3. To create an action:
  - a) Specify the "Name".  
E.g. *OpenUcorImportExportList*.
  - b) Select "Wizard > Open Dialog"
  - c) Select "Select" and select the dialog ID from the list

The corresponding SCPI command is automatically displayed and can be later modified.

4. Select "Add" to store the new action in the list of user key actions.

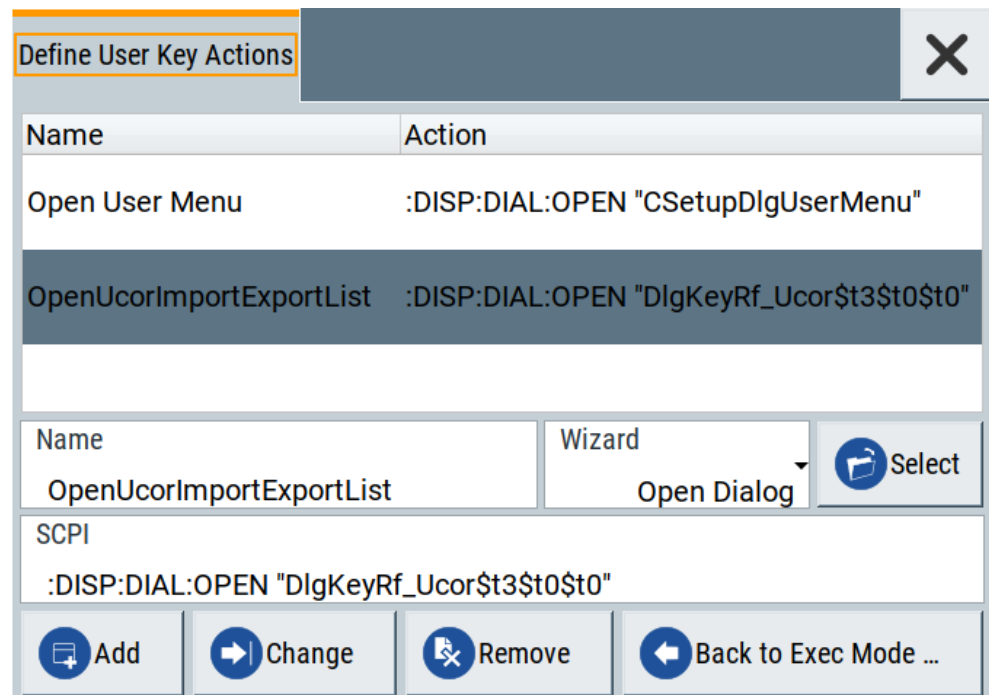

5. To execute the created action, press ★ (User).  
In the list of actions ("Select Action to Execute" dialog), navigate to the required action.  
In this example, this is "OpenUCORImportExportList".



Define User Key Actions	
Name	Action
OpenUCORImportExportList	:DISP:DIAL:OPEN "DlgKeyRf_Ucor\$t3\$t0..."
Open User Menu	:DISP:DIAL:OPEN "CSetupDlgUserMenu"

The R&S SMA100B executes the action and opens the dialog.

## 12.3 Managing Licenses and License Keys

An option is ready to operate after it is enabled with a license keycode supplied with the option. The license key is delivered as a file or on paper. Unregistered licenses must be registered for a particular instrument before the corresponding option can be enabled for operation.



For reliable operation, a software option usually requires the latest firmware version. The required version is specified in the delivery. If your instrument works with a former firmware version, update the firmware before enabling the software option.

The firmware update is described in the R&S SMA100B service manual.

### 12.3.1 Manage License Keys Settings

This dialog is the central dialog for licenses registration and performing the required instrument-related steps during the process of unregistration.

Access:

1. Select "System Config > Setup > Instrument Assembly > Manage License Keys > Manage License Keys".

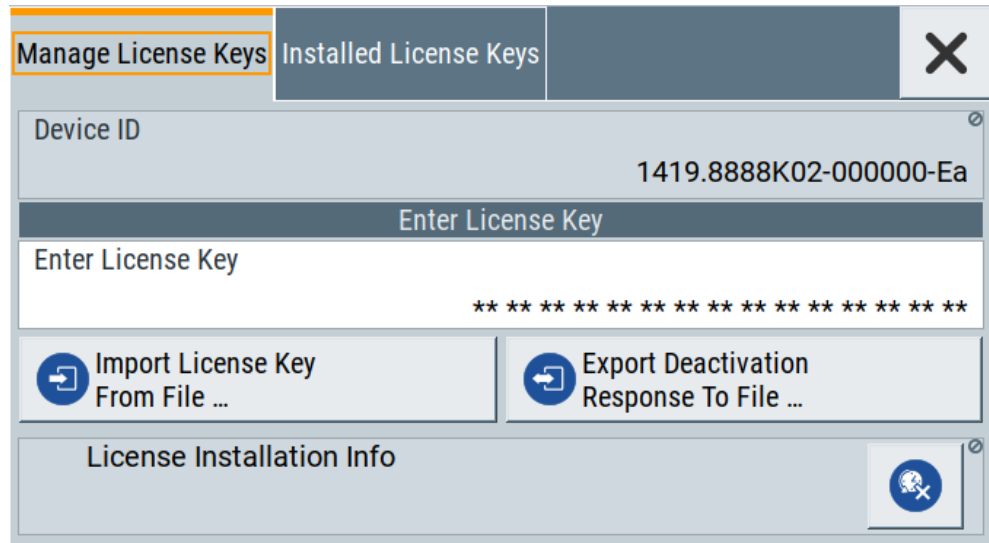

2. Select "System Config > Setup > Instrument Assembly > Manage License Keys > Installed License Keys".

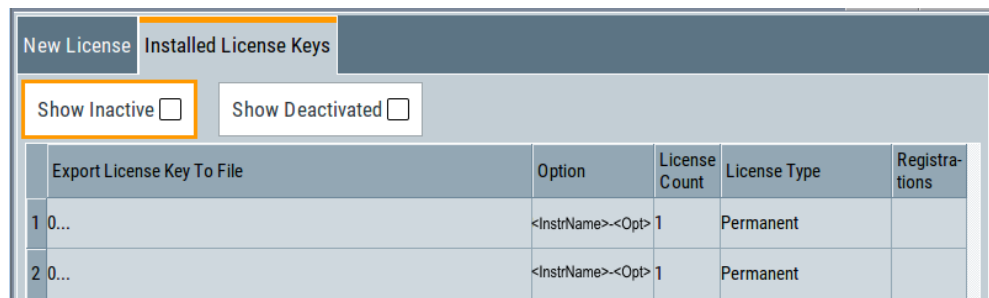

In the "New License" tab, you can activate licenses for newly purchased or newly registered options. The "Installed License Keys" tab enables you to cancel already registered options, or move licenses.

**Settings**

Device ID..... 350

Enter License Key..... 351

Import License Key from File..... 351

Export Deactivation Response to File..... 351

License Installation Info..... 351

Installed License Keys..... 351

- └ Show Inactive..... 351
- └ Show Deactivated..... 351
- └ Installed License Keys Table..... 351

**Device ID**

Displays the instrument-specific identification number. The device ID is a unique string with the following structure:

<stock number>-<serial number>-<checksum>

**Enter License Key**

Type here the license key provided with the option.

For license keys delivered as a file, use [Import License Key from File...](#)

**Import License Key from File...**

Opens a dialog for selecting the file with the license key.

Use this function also to import the deactivation key file generated by the R&S License Manager online tool (see [How to Move a Portable License](#)).

**Export Deactivation Response to File...**

Exports the generated deactivation response key to a file and opens a file management dialog to save the file.

This key is required during the unregistration process, e.g. when you want to deinstall an option or have a portable option, which you want to register later on another instrument (see [How to Move a Portable License](#)).

**License Installation Info**

Indicates status information on the performed actions.

**Installed License Keys**

Access: select "System Config > Setup > Instrument Assembly > Manage License Keys > Installed License Keys".

Comprises information on the installed options.

**Show Inactive ← Installed License Keys**

Enables the display of the inactive (expired) licenses in the [Installed License Keys Table](#).

**Show Deactivated ← Installed License Keys**

Enables the display of the deactivated licenses in the [Installed License Keys Table](#).

See [How to Move a Portable License](#) for information on how to activate deactivated licenses.

**Installed License Keys Table ← Installed License Keys**

Shows information on the currently installed options.

"Export License Key to File"

Opens a dialog to save the generated license key file. This file is required during the unregistration process.

If you have a portable unregistered option, you can register it later on another instrument (see [How to Move a Portable License](#)).

"Option"

Displays the option short designation.

**Tip:** Open the [Hardware Options/Software Options](#) dialog to retrieve more information about the installed options.

"License Count"

Displays the number of the licenses for the selected option key.

- "License Type" Displays the type of license.  
A license type determines the common qualification application duration and the portability of a license. The following license types are provided: evaluation, permanent, portable, quantified, time-controlled with a duration of 1, 3, 6 or 12 months. A license can also be deactivated or expired.  
For time limited licenses, the left time of applicability is displayed too.
- "Registrations" (reserved for future use)

### 12.3.2 How to Move a Portable License

This example is intended to explain how to perform the required steps at the instrument.

Use a USB flash drive to transfer the license key files between the instruments and the browser.



We assume knowledge about the handling of the R&S License Manager online tool and the description of the whole process.

1. Open your browser. Enter <https://extranet.rohde-schwarz.com/service>.  
Select "Manage Licenses > Move Portable License".  
The first step requires the Device IDs of the source and target instruments.
2. To find out the Device IDs, proceed as follows:
  - a) On the source instrument, select "System Config > Setup > Instrument Assembly > Manage License Keys > Manage License Keys > Device ID".

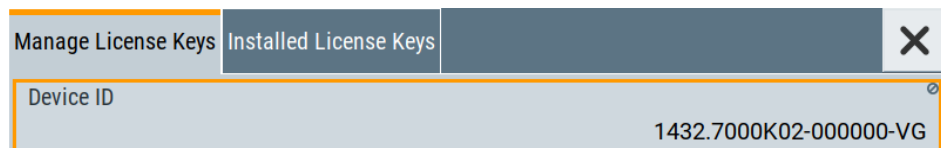

- b) On the target instrument, select "System Config > Setup > Instrument Assembly > Manage License Keys > New License > Device ID".
  - c) In the browser, select "Manage Licenses > Move Portable License > Select Devices" and enter the Device IDs.
3. On the source instrument, select "System Config > Setup > Instrument Assembly > Manage License Keys > Installed License Keys > License Keys Table".  
Navigate to the portable license you want to move.  
Select the "Export License to File" column.  
A standard file manager dialog opens.
4. Enter a filename. Save the exported license key, e.g.  
`k123_portable_key_to_move.xml`.
5. In the browser, select "Manage Licenses > Move Portable License > Select License (from file)" and select the exported license key.

Check the selection. Create the deactivation key. Save it to file.

6. On the source instrument, select "System Config > Setup > Instrument Assembly > Manage License Keys > Manage License Keys > Import License Keys from File".  
Select the transferred deactivation key.
7. On the source instrument, select "System Config > Setup > Instrument Assembly > Manage License Keys > Manage License Keys > Export Deactivation Response to File".
8. In the browser, go to "Manage Licenses > Move Portable License > Install Deactivation Key (from file)".  
Enter the deactivation response of the instrument.  
The license is deactivated for the source instrument.
9. In the "Manage Licenses > Move Portable License", go to step "Create License" to generate a license key for this portable option and the selected target instrument.  
Download the license key as a file. Transfer it to the target instrument.
10. In the target instrument, select "System Config > Setup > Instrument Assembly > Manage License Keys > New License > Import License Keys from File".  
Select the created license key file.

The portable option is installed on the target instrument.

## 12.4 Using the Security Settings

The protection function of the R&S SMA100B offers several levels to activate particular functions like self-test or tests for service purposes specifically.

### Protection

The five protection levels are automatically active on startup, the protection levels, that means all protected functions are locked.

To unlock a protection level:

- ▶ In the "System Config > Setup > Security > Protection", enter the correct password.

To lock a protection level:

- ▶ Clear the corresponding checkbox.

### Protection levels

The following functions are protected in the respective levels:

- Protection level 1  
Protects against accidental changes, like, for example, the clock and date, several internal adjustments functions and the self-test, as well as network settings or the instrument hostname.  
You can access this level with the password 123456.

- Protection level 2  
Unlocks protected service functions. It is accessible to authorized personnel of Rohde & Schwarz service department only.
- Protection level 3 to 5  
Are reserved for internal use.

### Security

The security concept of the R&S SMA100B helps you to protect your instrument against uncontrolled access and changes. All provided security services require that you enter the security password.

Provided security services are:

- **General** security parameters, such as:
  - **USB storage** that secures controlled access to the mass memory of the instrument
  - **Volatile mode** that prevents information to be written to the internal memory permanently.
  - **Sanitizing** that prevents the instrument from leaving a secure environment with stored user information.
  - **Annotation** frequency and amplitude prevent reading the display.
  - **Secure Update Policy** check that verifies the integrity and origin of the firmware package to be installed.  
To access the settings of these topics, see [Setting Security Parameters > "Secure Update Policy"](#) on page 356.
- **Password** management secures controlled user access to the instrument  
With the two-step password concept, you can assign a user-defined password for the operating system, and a security password for accessing the mass storage of the instrument.  
See also [Chapter 12.4.4, "Password Management"](#), on page 363.
- **LAN services** secure controlled network access  
You can individually lock and unlock supported LAN interface services. Also you can activate and deactivate SMB client and SMB server, that use versions 1.0 and 2.0 of the SMB protocol. See [Chapter 12.4.3, "Configuring LAN Services"](#), on page 361.  
Remote control via LAN interface requires that the interface is activated, but you can enable the required services specifically.
- **User interface** prevents front panel operation and/or reading the display.

For more information, see the document R&S SMA100B Instrument Security Procedures.

## 12.4.1 Protection Level Settings

Access:

- ▶ Select "System Config > Setup > Security > Protection".

Protection Level 1	<input checked="" type="checkbox"/>	<input type="text" value="Password"/> <span style="float: right;">*****</span>
Protection Level 2	<input checked="" type="checkbox"/>	<input type="text" value="Password"/> <span style="float: right;">*****</span>
Protection Level 3	<input checked="" type="checkbox"/>	<input type="text" value="Password"/> <span style="float: right;">*****</span>
Protection Level 4	<input checked="" type="checkbox"/>	<input type="text" value="Password"/> <span style="float: right;">*****</span>
Protection Level 5	<input checked="" type="checkbox"/>	<input type="text" value="Password"/> <span style="float: right;">*****</span>

The "Protection" dialog provides access to the unlocking of different protection levels.

Several functions in the instrument are password-protected to prevent for example accidental changes, "[Protection](#)" on page 353.

The remote commands required to unlock a protected stage are described in [Chapter 14.17, "SYSTem Subsystem"](#), on page 690.

#### Protection Level/Password

Unlocks the selected level of protection, if you enter the correct password.

The default protection level 1 password is 123456.

To lock the protection level again, clear the checkbox.

Remote command:

`:SYSTem:PROTECT<ch>[:STATe]` on page 698

## 12.4.2 Setting Security Parameters

Access:

- ▶ Select "System Config > Setup > Security > Security > General".

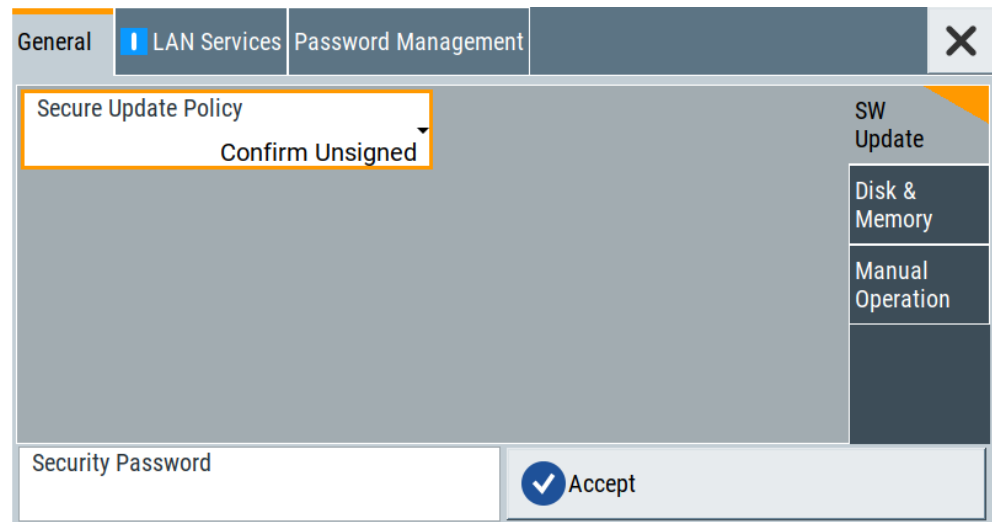

In the "General" tab, you can determine the security level for firmware updates, and configure the security settings for the mass memory and manual operation.



All modified settings in this dialog are not applied until you enter the [Security Password](#) and confirm with [Accept](#).

#### 12.4.2.1 Update Policy Security Settings

Access:

- ▶ Select "System Config > Setup > Security > Security > General > SW Update".

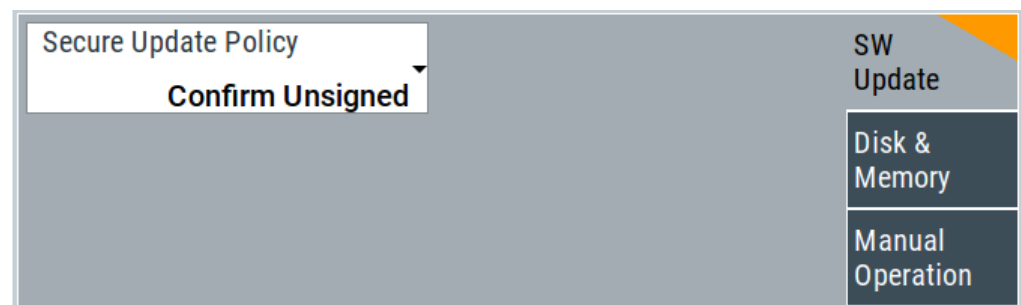

The SW Update tab enables you to select the security mode for firmware updates.

The remote commands available to control security settings are described in [Chapter 14.17, "SYSTem Subsystem"](#), on page 690.

#### Secure Update Policy

Allows you to configure the automatic signature verification for firmware installation.

To apply the change: enter the security password and confirm with "Accept". Otherwise the change has no effect.



See also:

- [Chapter 12.4, "Using the Security Settings"](#), on page 353 for more information on the security concept.
- The release notes for details on signature verification when installing new or former firmware versions, available at [www.rohde-schwarz.com/firmware/sma100b](http://www.rohde-schwarz.com/firmware/sma100b).

"Confirm Unsigned"

Performs the signature verification.

If the check detects any discrepancies, the instrument issues a warning message. You can still update the firmware or reject updating.

This setting also enables you to downgrade the firmware version.

"All Packages" Accepts all packages without signature verification.

"R&S Signed Packages"

Performs the signature check.

If the check detects any discrepancies, the instrument issues a warning message and locks the update to this firmware.

Remote command:

:SYSTem:SECurity:SUPolicy on page 707

#### 12.4.2.2 Disk & Memory Security Settings

Access:

- ▶ Select "System Config > Setup > Security > Security > General > Disk & Memory".

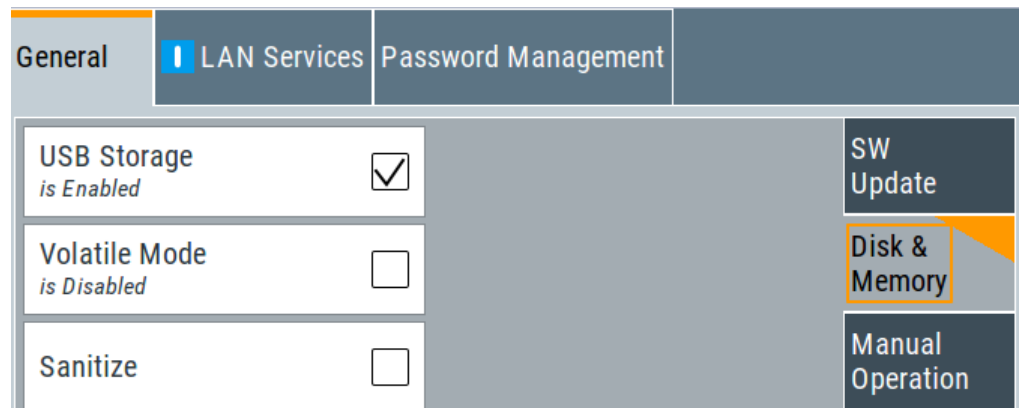

The "Disk & Memory" tab secures controlled access to the mass memory and prevents information from leaving a secure environment.

The remote commands available to control security settings are described in [Chapter 14.17, "SYSTem Subsystem"](#), on page 690.

##### USB Storage

Activates the access to external USB storage media.

To apply the change: enter the security password and confirm with "Accept". Otherwise the change has no effect.

See also [Chapter 11.9.4, "Using a USB Storage Device for File Transfer"](#), on page 330.

**Note:** Remove all USB memory devices before disabling the USB storage. If any USB memory device remains connected, disabling is blocked, and the instrument returns a warning message.

The microSD card is also considered a USB memory device and must be removed. If you have sealed the SD card slot, you can not disable the USB storage.

### Volatile Mode

Activates volatile mode, so that no user data can be written on the internal memory permanently.

In volatile mode:

- Data that the instrument normally stores on the internal memory is redirected to volatile memory.
- The user directory is mapped to the volatile memory. You access the temporary data just as data stored in the `/var/user/`, see [Chapter 11.3, "Protecting Data"](#), on page 310.
- Data on the internal memory cannot be changed. It is protected against modification or erasure.
- You can only save data:
  - Temporarily in the volatile memory
  - On a connected external storage device, such as a memory stick

To activate volatile mode: enter the security password, confirm with "Accept" and reboot the instrument. Otherwise the change has no effect.

Activated volatile mode is indicated by the icon .

Remote command:

`:SYSTem:SECurity:VOLMode[:STATe]` on page 699

### Sanitize

Executes the erase procedure that sanitizes the internal memory.

If the instrument is subject to high security, and you have not enabled the volatile mode, the internal flash memory holds user-data, i.e. it poses a security risk. The sanitizing function makes sure that no user information is stored on the instrument when it leaves the secure environment.

To apply the change: enter the security password and confirm with "Accept". Otherwise the change has no effect.

See also [Chapter 12.4, "Using the Security Settings"](#), on page 353 for more information on the security concept.

Remote command:

`:SYSTem:SECurity:SANitize[:STATe]` on page 707

#### 12.4.2.3 Manual Operation Security Settings

Access:

- ▶ Select "System Config > Setup > Security > Security > General > Manual Operation".

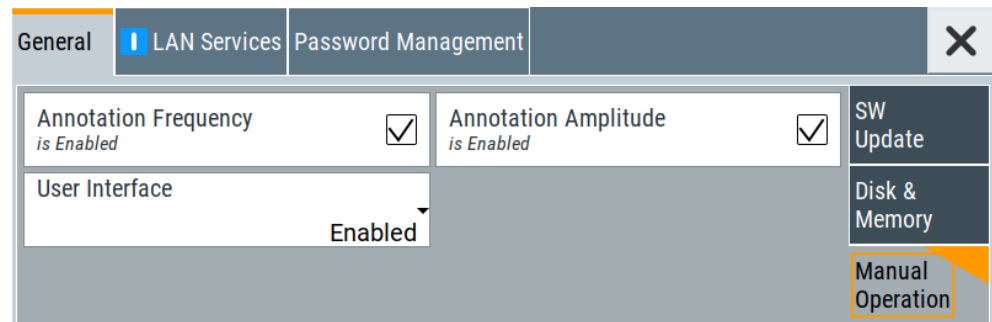

The "SW Update" tab enables you to lock front panel operation and/or reading the display.

The remote commands available to control security settings are described in:

- [Chapter 14.9, "DISPlay Subsystem"](#), on page 462
- [Chapter 14.17, "SYSTem Subsystem"](#), on page 690.

#### Annotation Frequency

Enables the display of the currently used frequency in the status bar.

How to: see ["Disabling the frequency and level indication in the status bar"](#) on page 367.

Remote command:

`:DISPlay:ANNotation:FREQuency` on page 465

#### Annotation Amplitude

Enables the display of the currently selected level in the status bar.

How to: see ["Disabling the frequency and level indication in the status bar"](#) on page 367.

Remote command:

`:DISPlay:ANNotation:AMPLitude` on page 465

#### User Interface

Allows you to lock the controls for manual operation and the display individually.

How to: see ["Deactivating the user interface"](#) on page 367.

See also [Chapter 12.4, "Using the Security Settings"](#), on page 353.

"Enabled" Enables the display and all controls for the manual operation of the instrument.

**"Touchscreen Off"**

Locks the touch sensitivity of the screen.

This security feature protects the instrument against unintentional change of settings by accidentally touching of the screen.

Still available controls for manual operation are:

- The keys at the front panel, including the rotary knob
- The external mouse and keyboard
- Remote operation over VNC

The instrument indicates the locked touchscreen by an icon .

Unlocking is possible via VNC, external controls or remote control.

**"VNC Only"**

Locks the keys at the front panel, the touchscreen and externally connected keyboard and mouse.

The display on the screen remains and shows the current settings and changes.

The instrument indicates the activated "VNC only" feature by the icon .

Unlocking is possible via VNC or turning off and on again.

**"Display Only"**

Locks the manual operation of the instrument. The display on the screen remains and shows the current settings and changes.

This security feature protects the instrument against unauthorized access, but still shows the current settings and processes, for example when you operate the instrument via remote control.

The function disables:

- The touchscreen functionality of the display
- The keys at the front panel of the instrument
- The external mouse and keyboard

The instrument indicates the locked controls by a padlock  softkey.

How to unlock: see ["Unlocking \(reactivating\) the user interface for manual operation"](#) on page 367.

**"Disabled"**

Locks the display and all controls for the manual operation of the instrument.

This security feature protects the instrument against unauthorized reading and access, for example when you operate the instrument via remote control.

The function disables:

- The display
- The touchscreen
- The keys at the front panel of the instrument
- The external mouse and keyboard

The screen shuts off and displays a padlock symbol  instead.

How to unlock: see ["Unlocking \(reactivating\) the user interface for manual operation"](#) on page 367.

Remote command:

:SYSTem:ULOCK on page 696

:SYSTem:DLOCK on page 696

:SYSTem:KLOCK on page 696

### Enabling a locked user interface for manual operation

Follow the instructions listed in ["Unlocking \(reactivating\) the user interface for manual operation"](#) on page 367.

Remote command:

:SYSTem:ULOCK on page 696

:SYSTem:DLOCK on page 696

:SYSTem:KLOCK on page 696

## 12.4.3 Configuring LAN Services

Access:

1. Select "System Config > Setup > Security > Security > LAN Services > Main Services".

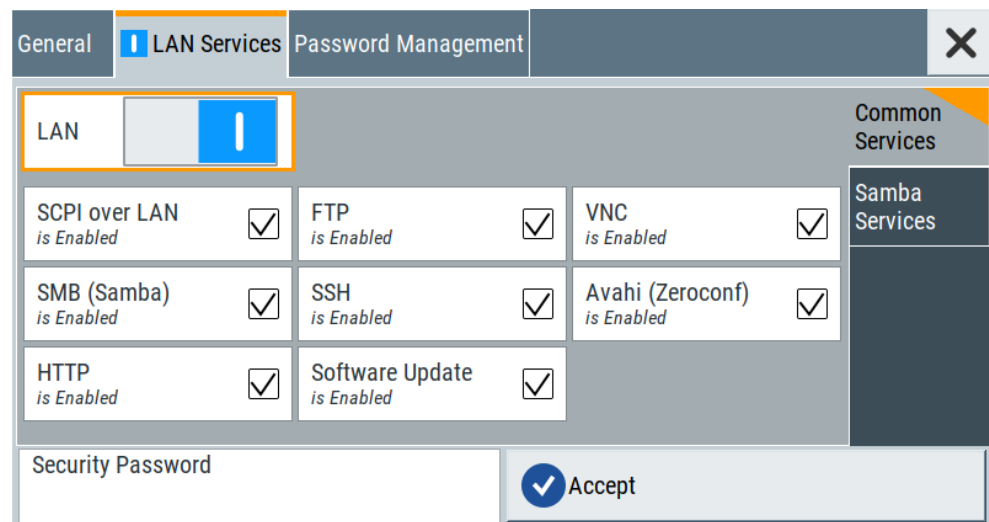

In the "Main Services" side tab, you can individually enable or disable the supported LAN interface services.

2. Select "System Config > Setup > Security > Security > LAN Services > Samba Services".

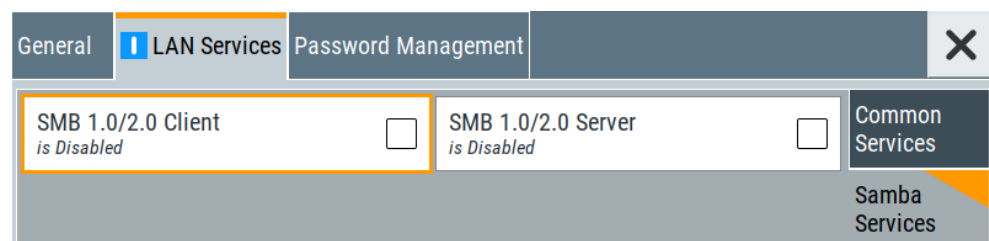

In the "Samba Services" side tab, you can activate older versions of the SMB client and SMB server.

How to:

- ["Disabling the LAN interface"](#) on page 366
- ["Disabling LAN services"](#) on page 367
- ["Activating SMB version 1.0/2.0 client and server"](#) on page 367

### Common Services

Enable or disable the LAN interface and supported LAN interface services.

#### LAN ← Common Services

Enables the LAN interface in general, and thus provides remote access via all unlocked services.

#### Enable LAN Services individually ← Common Services

Enables or disables the following interface services individually.

"SCPI over LAN"

Activates access over LAN to control the instrument remotely, by using SCPI (Standard Commands for Programmable Instruments) commands.

See also ["Starting a remote control session over LAN with R&S VISA"](#) on page 408.

"VNC"

Activates access via VNC (Virtual Network Computing) interface, a graphical desktop sharing system that uses RFB protocol to control the instrument remotely.

See also [Chapter 13.9, "Operating the R&S SMA100B Remotely via VNC"](#), on page 424.

"SSH"

Activates access via SSH (Secure Shell), a network protocol for secure data communication.

"HTTP"

Activates access via HTTP (Hyper Text Transfer Protocol), the application protocol for hypermedia information systems.

"FTP"

Activates access via FTP (File Transfer Protocol), used to transfer files from a host to the instrument and vice versa.

See also [Chapter 11.9.2, "Accessing the File System of the R&S SMA100B via ftp"](#), on page 327.

"SMB (Samba)"

Activates access to SMB (Server Message Block), used for providing shared access to files, printers and serial ports of a network.

See also [Chapter 11.9.3, "Accessing the R&S SMA100B File System via SMB \(Samba\)"](#), on page 328.

"Avahi (Zeroconf)"

Activates Avahi, a service for automatic configuration of the instrument in a network environment.

"Software Update"

Allows updating the software.

### Samba Services

Activate or deactivate support of SMB client and SMB server version 1.0 and 2.0 of the SMB protocol.

Support of version 1.0 and 2.0 is additional to the current SMB protocol version supported in the firmware. This firmware supports SMB protocol versions up to version 4.

#### **SMB 1.0/2.0 Client ← Samba Services**

Activates support of the SMB client compatible with SMB protocol versions 1.0 and 2.0.

#### **SMB 1.0/2.0 Server ← Samba Services**

Activates support of the SMB server compatible with SMB protocol versions 1.0 and 2.0.

#### **Security Password**

Enters the password that is required to enable or to disable the settings protected by a security password. Default is *123456*.

How to:

- ["Disabling the LAN interface"](#) on page 366
- ["Disabling LAN services"](#) on page 367
- ["Changing the default security password"](#) on page 366.

#### **Accept**

Applies the modified settings, provided the security password is entered and correct.

### 12.4.4 Password Management

Access:

1. Select "System Config > Setup > Security > Security > Password Management > User Password".

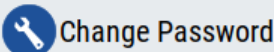
General	LAN Services	Password Management	
Valid for VNC, FTP and SMB (Samba) access			User Password
User Name		instrument	Security Password
Old Password			
New Password			
Confirm Password			
			

In this tab, you can assign the security and a user-defined password.

2. Select "System Config > Setup > Security > Security > Password Management > Security Password".

The screenshot shows a web interface for password management. At the top, there are four tabs: 'General', 'LAN Services', 'Password Management', and an unlabeled tab. The 'Password Management' tab is active. Below the tabs are three input fields: 'Old Password', 'New Password', and 'Confirm Password'. To the right of these fields are two labels: 'User Password' and 'Security Password'. At the bottom right is a 'Change Password' button with a wrench icon.

How to:

- ["Changing the default user password of the instrument"](#) on page 366.
- ["Changing the default security password"](#) on page 366.

#### User Name

Indicates the user name used for access to the Linux operating system and valid for VNC, FTP and SMB (Samba) access.

#### User Password

Access: select "System Config > Setup > Security > Security > Password Management > User Password".

Allows you to change and confirm the user password.

#### Old Password ← User Password

Enters the current user password. The default password is "instrument".

**Note:** We recommend that you change the default password before connecting the instrument to a network.

How to:

- ["Changing the default user password of the instrument"](#) on page 366.
- ["Changing the default security password"](#) on page 366.

#### New Password ← User Password

Enters the new user password.

The security password can contain decimal characters only.

#### Confirm Password ← User Password

Confirms the new user password by repeating.



How to:

- ["Changing the default user password of the instrument"](#) on page 366.
- ["Changing the default security password"](#) on page 366.

#### **Change Password ← User Password**

Changes the user password accordingly.

#### **Security Password**

Access: select "System Config > Setup > Security > Security > Password Management > Security Password".

Enables you to change and confirm the security password.

#### **Old Password ← Security Password**

Enters the currently used security password. The default password is '123456'.

**Note:** We recommend that you change the default password before connecting the instrument to a network.

How to:

- ["Changing the default user password of the instrument"](#) on page 366.
- ["Changing the default security password"](#) on page 366.

The security password is required when changing the status of the USB and LAN interface.

#### **New Password ← Security Password**

Enters the new security password.

The security password can contain decimal characters only.

#### **Confirm Password ← Security Password**

Confirms the new security password by repeating.

How to:

- ["Changing the default user password of the instrument"](#) on page 366.
- ["Changing the default security password"](#) on page 366.

#### **Change Password ← Security Password**

Changes the password accordingly.

### **12.4.5 How to Prevent Unauthorized Access**

The default computer name and user password are *instrument*. The user password is the password required for VNC, FTP and SMB (samba) connections. If, for example, the VNC service or FTP are enabled, anyone in the network who knows the computer name and user password of the instrument can access it.

The default security password is *123456*. The security password is required when changing the status of the USB and LAN interface.

To prevent unauthorized access, use the following configurations exclusively or complementary:

- ["Changing the default user password of the instrument"](#) on page 366

- ["Changing the default security password"](#) on page 366
- ["Disabling the LAN interface"](#) on page 366
- ["Disabling LAN services"](#) on page 367
- ["Activating SMB version 1.0/2.0 client and server"](#) on page 367
- ["Disabling the frequency and level indication in the status bar"](#) on page 367
- ["Deactivating the user interface"](#) on page 367

If security is a concern, see the document instrument security procedures for comprehensive description.

### Changing the default user password of the instrument

- ▶ **Note:** We recommend that you change the default password before connecting the instrument to a network.

How to:

- ["Changing the default user password of the instrument"](#) on page 366.
  - ["Changing the default security password"](#) on page 366.
- a) Select "System Config > Setup > Security > Security > Password Management > User Password".
  - b) Enter the current password in the "Old Password" field.
  - c) Enter the new password in the "New Password" and "Confirm Password" fields.
  - d) Select "Change Password".

The user password is changed; the user name is displayed ("Security > Password Management > User Password > User Name").

### Changing the default security password

- ▶ **Note:** We recommend that you change the default password before connecting the instrument to a network.

How to:

- ["Changing the default user password of the instrument"](#) on page 366.
  - ["Changing the default security password"](#) on page 366.
- a) Select "System Config > Setup > Security > Security > Password Management > Security Password".
  - b) Enter the current password in the "Old Password" field.  
The default password is *123456*.
  - c) Enter the new password in the "New Password" and "Confirm Password" fields.
  - d) Select "Change Password".

### Disabling the LAN interface

1. Select "System Config > Setup > Security > Security > LAN Services > Main Services".
2. Select "LAN > Off".

All LAN connections and hence all LAN services are disabled.

**Disabling LAN services**

1. Select "System Config > Setup > Security > Security > LAN Services > Main Services".
2. Select, for example, "FTP > Off" or "VNC > Off".
3. Enter the [Security Password](#).
4. Select "Accept".

**Activating SMB version 1.0/2.0 client and server**

By default, support of SMB client and SMB server of the SMB protocol versions 1.0 and 2.0 is deactivated.

Activate support only, if needed:

1. Select "System Config > Setup > Security > Security > LAN Services > Samba Services".
2. Select "SMB 1.0/2.0 Client > On" and "SMB 1.0/2.0 Server > On".
3. Enter the [Security Password](#).
4. Select "Accept".

**Disabling the frequency and level indication in the status bar**

These settings are useful to prevent unauthorized personnel from reading the display, when you remotely control the instrument from a different location.

1. Select "System Config > Setup > Security > General > Manual Operation".
2. Select "Annotation Frequency > Off" or "Annotation Amplitude > Off".
3. Enter the [Security Password](#).
4. Select "Accept".

**Deactivating the user interface**

1. Select "System Config > Setup > Security > General > Manual Operation".
2. Select "User Interface > Disabled".
3. Enter the [Security Password](#).
4. Select "Accept".

The screen shuts off and displays a padlock symbol  instead.

There are further possible configurations. For details, see "[User Interface](#)" on page 359.

**Unlocking (reactivating) the user interface for manual operation**

1. In manual operation:

- a) On the instrument's keypad or external keyboard, press any key.  
The instrument prompts you to enter the security password for unlocking.

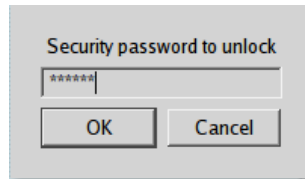

If you press the character of the first key, the input field accepts the character immediately.

- b) Delete the entry before inserting the password.  
Enter the security password `123456`.
2. In remote control mode:
    - a) Send the command `SYST:ULOC ENABled` to release all locks at once.
    - b) Send the command `SYST:KLOC OFF` to unlock the keyboard and touchscreen.
    - c) Send the command `SYST:DLOC OFF` to release all locks.

Via remote control, there is no password required.

## 12.5 Undoing or Restoring Actions

"Undo" is a function that removes the effect of the last action on the instrument and reverts it to an older state. Conversely, "Redo" restores a previously undone action.

You can "Undo/Redo" actions according to two criteria:

- Step by step  
Gradually undo/redo the actions in reverse order as previously performed. Depending on the available memory the "Undo/Redo" steps may restore all actions.
- Multiple steps at once  
Select any specific action in the history list to "Undo/Redo" multiple actions in a single step.  
**Note:** This mode requires a system restoration file on the instrument.

**Access:**

- ▶ Select "Setup > Settings > Undo/Redo".

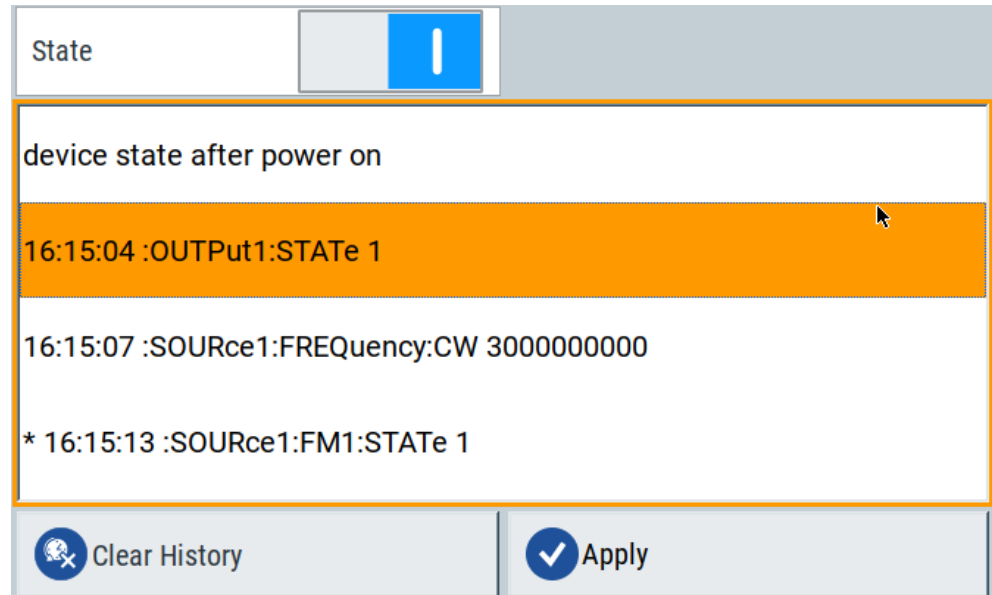

The dialog contains all functions for enabling the "Undo/Redo" functionality.

**Settings:**

State.....	369
History List.....	369
Clear History.....	369
Apply.....	369

**State**

Enables the recording of the performed actions.

**History List**

Lists the performed actions, provided "Undo/Redo" state is "On".

**Clear History**

Deletes the recorded list of the performed steps.

**Apply**

Performs the "Undo/Redo".

If you select a previously performed action of the list, all subsequent actions are undone. The list entries remain.

If you select a subsequently executed action, you can restore all the actions undone up to this state.

## 12.6 Shutting Down and Rebooting the Instrument

The [Power On/Standby] front panel key switches the instrument from the standby to the ready state or vice versa. In remote operation from a remote computer or in manual control, there is another possibility to shut down the instrument or to reboot the system.

Access:

- ▶ Select "System Config > Setup > Maintenance > Shut Down".

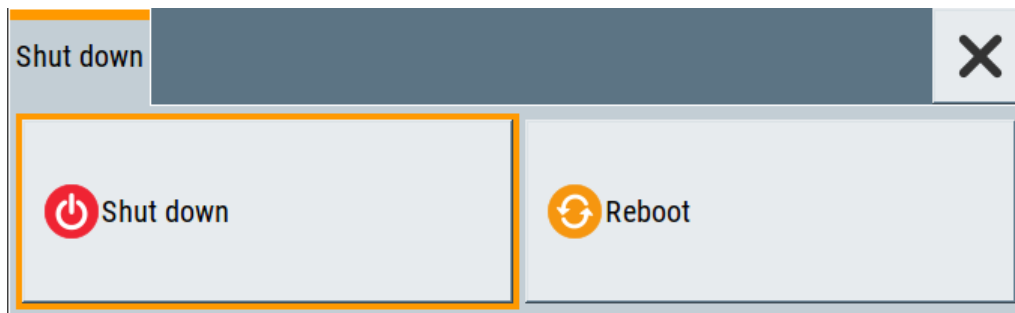

**Remote command:**

- `:SYSTem:REBoot` on page 714
- `:SYSTem:SHUTdown` on page 714

# 13 Network Operation and Remote Control



The description in this section requires basic knowledge of the remote control operation. Definitions specified in the SCPI standard are not provided.

You find some basic information to the SCPI syntax, command lists, and general programming recommendations in [Chapter A.1, "Additional Basics on Remote Control"](#), on page 751.

See also [Chapter A.1.5, "Status Reporting System"](#), on page 763.

As an alternative to the interactive operation directly at the instrument, you can operate the R&S SMA100B also from a remote location.

The [Figure 13-1](#) shows the possibilities of the physical connection (interfaces) for the remote access.

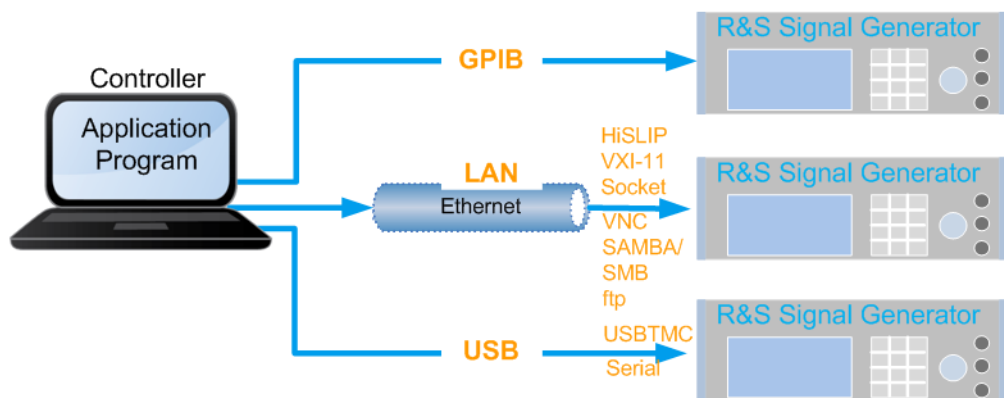

**Figure 13-1: Supported remote connections**

The various interfaces provide flexible access to the instrument, such as *remote control*, *remote operation* or *remote file access*. These **remote access modes** are fundamentally different, although they are often considered interchangeable.

See:

- [Overview of Remote Access Modes](#)
- [1GP72: Connectivity of Rohde&Schwarz Signal Generators](#)
- [Chapter 3.1.7, "Connecting to LAN"](#), on page 31

## 13.1 Overview of Remote Access Modes

This section outlines the possible access modes and their major characteristics.

**Remote control (SCPI)**

- A remote PC controls the instrument, usually via VISA (Virtual Instrument Software Architecture) interfaces.
- Remote control disables the manual operation of the instrument; you can set different lock states.
- The GUI is not visible.
- Remote control commands (SCPI) perform the settings, either individually or in sequences (SCPI programs).
- Using SCPI programs is faster than the manual operation, since they automate repeating applications.

**Remote operation (VNC)**

- A remote device accesses the instrument via the common platform technology VNC (Virtual Network Computing).
- The protocol allows simultaneous operation from several remote devices and the instrument nevertheless remains locally operable.
- The GUI is visible.
- To perform the settings, you can operate the instrument as with the manual control.
- During remote operation via VNC, the direct control of the instrument is not disabled.  
You can control the instrument from the front panel and via the remote computer alternately.
- Clients supporting remote operation depend on the used remote device, see [Table 13-1](#).
- How to: see [Chapter 13.9, "Operating the R&S SMA100B Remotely via VNC"](#), on page 424.

**Table 13-1: Supported VNC operation modes**

Remote device	VNC client	Requirements	Characteristics
Desktop (Windows, Linux, Mac™OS)	<ul style="list-style-type: none"> <li>• Ultr@VNC</li> <li>• Other dedicated client software</li> </ul>	<i>Ultr@VNC or Client Software</i> must be installed.	Fast, supports several options like full screen mode or auto-login.
	<ul style="list-style-type: none"> <li>• Any web browser</li> </ul>	<i>Java Runtime</i> must be installed and activated in the browser settings.	Fast and convenient - only the instrument address required. Java runtime is sometimes considered as security concern.
	<ul style="list-style-type: none"> <li>• Web browser with HTML5</li> </ul>	<i>Web sockets</i> must be supported.	Slower than the other modes. No additional installation or activation required. No security concern.
Smart device (Tablet/ smartphone)	<ul style="list-style-type: none"> <li>• Dedicated client App</li> </ul>	<i>App</i> must be installed.	Fast, supports several options like full screen mode or auto-login.
	<ul style="list-style-type: none"> <li>• Web browser with HTML5</li> </ul>	<i>Web sockets</i> must be supported.	Support of QR code scanning Slower than a dedicated App.



**Remote file access (FTP, SAMBA/SMB)**

- A remote client accesses the instrument's file system, using the protocols FTP (file transfer protocol) and SAMBA/SMB (server message block).
- The protocols enable you to transfer files from or to the instrument and to get direct access to its file sharing directory `share`.

How to:

[Chapter 11.9, "How to Transfer Files from and to the Instrument"](#), on page 325.

["Activating SMB version 1.0/2.0 client and server"](#) on page 367

## 13.2 Remote Control Interfaces and Protocols

The instrument supports various interfaces for remote control. The table gives an overview on the connectivity:

**Table 13-2: Remote control interfaces and protocols**

Interface	Protocols, VISA <sup>*)</sup> address string and library	Remarks
Local area network (LAN)	<ul style="list-style-type: none"> <li>• <b>HiSLIP</b> High-Speed LAN Instrument Protocol (IVI-6.1) TCP/IP::host address::hislip0[::INSTR] VISA</li> <li>• <b>VXI-11</b> TCP/IP::host address[:: LAN device name][::INSTR] VISA</li> <li>• <b>Socket communication</b> (Raw Ethernet, simple Telnet) TCP/IP::host address[:: LAN device name]::&lt;port&gt;::SOCKET VISA or socket controller</li> </ul>	<p>The LAN connector is on the rear panel of the instrument.</p> <p>The interface is based on TCP/IP and supports various protocols.</p> <p>For a description of the protocols, refer to:</p> <ul style="list-style-type: none"> <li>• <a href="#">Chapter 13.2.1.2, "HiSLIP Protocol"</a>, on page 376</li> <li>• <a href="#">Chapter 13.2.1.3, "VXI-11 Protocol"</a>, on page 376</li> <li>• <a href="#">Chapter 13.2.1.4, "Socket Communication"</a>, on page 376</li> </ul>
USB	<ul style="list-style-type: none"> <li>• <b>USBTMC</b> USB::&lt;vendor ID&gt;::&lt;product ID&gt;:: &lt;serial number&gt;[::INSTR] VISA</li> </ul>	<p>The USB In connector is at the rear panel of the instrument.</p> <p>For a description of the interface, refer to <a href="#">Chapter 13.2.2, "USB Interface"</a>, on page 377</p>
GPIB (IEC/IEEE Bus Interface)	<ul style="list-style-type: none"> <li>• – GPIB::&lt;address&gt;[::INSTR] (no secondary address) VISA</li> </ul>	<p>Optional GPIB bus interfaces according to standard IEC 625.1/IEEE 488.1 are on the rear panel of the instrument.</p> <p>For a description of the interface, refer to <a href="#">Chapter 13.2.3, "GPIB Interface (IEC/IEEE Bus Interface)"</a>, on page 377.</p>

<sup>\*)</sup> VISA (Virtual Instrument Software Architecture) is a standardized software interface library providing input and output functions to communicate with instruments. A VISA installation on the controller is a prerequisite for remote control over LAN (when using VXI-11 or HiSLIP protocol), USB and serial interface. For remote control via socket communication VISA installation is optional. For more information, see [Chapter 13.3.1, "VISA Library"](#), on page 379.



Rohde & Schwarz provides the standardized I/O software library R&S VISA for communication with the instruments via TCP/IP (LAN: HiSLIP, VXI-11 and raw socket) or USB (USBTMC) interfaces.

R&S VISA is available for download at the Rohde & Schwarz website <http://www.rohde-schwarz.com/rsvisa>.

How to configure the remote control interfaces is described in [Chapter 13.7, "Controlling the R&S SMA100B Remotely"](#), on page 402.

### SCPI (Standard Commands for Programmable Instruments)

SCPI commands - messages - are used for remote control. Commands that are not taken from the SCPI standard follow the SCPI syntax rules. The instrument supports the SCPI version 1999. The SCPI standard is based on standard IEEE 488.2 and aims at the standardization of device-specific commands, error handling and the status registers. The tutorial "Automatic Measurement Control - A tutorial on SCPI and IEEE 488.2" from John M. Pieper (Rohde & Schwarz order number 0002.3536.00) offers detailed information on concepts and definitions of SCPI.

Tables provide a fast overview of the bit assignment in the status registers. The tables are supplemented by a comprehensive description of the status registers.

For more information, see also [Chapter A.1, "Additional Basics on Remote Control"](#), on page 751.

## 13.2.1 LAN Interface

To be integrated in a LAN, the instrument is equipped with a LAN interface, consisting of a connector, a network interface card and protocols.

For remote control via a network, the PC and the instrument must be connected via the LAN interface to a common network with TCP/IP network protocol. The TCP/IP network protocol and the associated network services are preconfigured on the instrument. Software for instrument control and (for specified protocols only) the VISA program library must be installed on the controller.

If several instruments are connected to the network, each instrument has its own IP address and associated resource string. The controller identifies these instruments by the resource string.

### 13.2.1.1 VISA Resource Strings

The VISA resource string is required to establish a communication session between the controller and the instrument in a LAN. The resource string is a unique identifier, composed of the specific IP address of the instrument and some network and VISA-specific keywords.

`TCPIP::host address[:,LAN device name][:INSTR]`

TCP/IP                   = designates the network protocol  
 host address           = designates the IP address or hostname of the instrument  
 [::LAN device name] = defines the protocol and the instance number of a subinstrument  
 [::INSTR]               = indicates the instrument resource class (optional)

The **IP address** (host address/computer name) is used by the programs to identify and control the instrument. It is automatically assigned by the DHCP server the first time the device is registered on the network. Alternatively, you can also assign its **LAN device name**.

If assigned, the IP address is displayed on home screen. You can adjust it manually with the parameter the "System Config > Remote Access > Network" > [IP Address Enabling a locked user interface for manual operation](#).

The following section lists the characteristics of the VISA resource strings for the corresponding interface protocols. The highlighted characters are crucial.

### HiSLIP

`TCP/IP::host address::hislip0[::INSTR]`

hislip0 = HiSLIP device name, designates that the interface protocol HiSLIP is used (mandatory)

**hislip0** is composed of [::HiSLIP device name[,HiSLIP port]] and must be assigned.

For details of the HiSLIP protocol, refer to [Chapter 13.2.1.2, "HiSLIP Protocol"](#), on page 376.

### VXI-11

`TCP/IP::host address[::inst0][::INSTR]`

[::inst0] = LAN device name, indicates that the VXI-11 protocol is used (optional)

**inst0** currently selects the VXI-11 protocol by default and can be omitted.

For details of the VXI-11 protocol, refer to [Chapter 13.2.1.2, "HiSLIP Protocol"](#), on page 376.

### Socket communication

`TCP/IP::host address::port::SOCKET`

port           = determines the used port number  
 SOCKET = indicates the raw network socket resource class

Socket communication requires the specification of the port (commonly referred to as port number) and of "SOCKET" to complete the VISA resource string with the associated protocol used.

The registered port for socket communication is port 5025.

See also [Chapter 13.2.1.4, "Socket Communication"](#), on page 376.

### 13.2.1.2 HiSLIP Protocol

The HiSLIP (**H**igh **S**peed **L**AN **I**nstrument **P**rotocol) is the successor protocol for VXI-11 for TCP-based instruments specified by the IVI foundation. The protocol uses two TCP sockets for a single connection - one for fast data transfer, the other for non-sequential control commands (e.g. `Device Clear` or `SRQ`).

HiSLIP has the following characteristics:

- High performance as with raw socket network connections
- Compatible IEEE 488.2 support for Message Exchange Protocol, Device Clear, Serial Poll, Remote/Local, Trigger, and Service Request
- Uses a single IANA registered port (4880), which simplifies the configuration of firewalls
- Supports simultaneous access of multiple users by providing versatile locking mechanisms
- Usable for IPv6 or IPv4 networks



Using VXI-11, each operation is blocked until a VXI-11 device handshake returns. However, using HiSLIP, data is sent to the device using the "fire and forget" method with immediate return. Thus, a successful return of a VISA operation such as `viWrite()` does not guarantee that the instrument has finished or started the requested command, but is delivered to the TCP/IP buffers.

For more information see also the application note:

[1MA208: Fast Remote Instrument Control with HiSLIP](#)

### 13.2.1.3 VXI-11 Protocol

The VXI-11 standard is based on the ONC RPC (Open Network Computing Remote Procedure Call) protocol which in turn relies on TCP/IP as the network/transport layer. The TCP/IP network protocol and the associated network services are preconfigured. TCP/IP ensures connection-oriented communication, where the order of the exchanged messages is adhered to and interrupted links are identified. With this protocol, messages cannot be lost.

### 13.2.1.4 Socket Communication

An alternative way for remote control of the software is to establish a simple network communication using sockets. The socket communication, also referred to as "Raw Ethernet communication", does not necessarily require a VISA installation on the remote controller side. It is available by default on all operating systems.

The simplest way to establish socket communication is to use the built-in telnet program. The telnet program is part of every operating system and supports a communication with the software on a command-by-command basis. For more convenience and to enable automation by means of programs, user-defined sockets can be programmed.

Socket connections are established on a specially defined port. The socket address is a combination of the IP address or the host name of the instrument and the number of the port configured for remote-control. All R&S SMA100B use port number 5025 for this purpose. The port is configured for communication on a command-to-command basis and for remote control from a program.

## 13.2.2 USB Interface

Option: R&S SMAB-B86

For remote control via the USB connection, the PC and the instrument must be connected via the USB type B interface. A USB connection requires the VISA library to be installed. VISA detects and configures the R&S instrument automatically when the USB connection is established. You do not have to install a separate driver.

USBTMC (USB Test & Measurement Class Specification) is a protocol that is built on top of USB for communication with USB devices. It defines class code information of the instrument, that identifies its functionality to load the respective device driver. Using VISA library, it supports service request, triggers, and other specific operations.

### 13.2.2.1 USB Resource String

The resource string represents an addressing scheme that is used to establish a communication session with the instrument. It is based on the instrument address and some instrument- and vendor-specific information.

The USB resource string syntax is as follows:

`USB::<vendor ID>::<product ID>::<serial number>[:INSTR]`

USB	= denotes the used interface
<vendor ID>	= is the manufacturer ID for Rohde & Schwarz
<product ID>	= is the product identification of the instrument
<serial number>	= is the individual serial number on the rear of the instrument
[:INSTR]	= indicates the instrument resource class (optional)

To set the USB resource string, see [Remote Access Settings](#).

#### Example:

`USB::0x0AAD::0x01DD::100001`

0x0AAD is the vendor ID for Rohde & Schwarz.

0x01DD is the product ID for the R&S SMA100B

100001 is the serial number of the particular instrument.

## 13.2.3 GPIB Interface (IEC/IEEE Bus Interface)

Option: R&S SMAB-B86

To be able to control the instrument via the GPIB bus, the instrument and the controller must be linked by a GPIB bus cable. A GPIB bus card, the card drivers and the program libraries for the programming language used must be provided in the controller.

### GPIB address

The controller must address the instrument with the GPIB bus channel (see [Chapter 13.4.3, "GPIB Address Settings"](#), on page 386). GPIB provides channel addresses from 0 to 30.

The GPIB resource string syntax is as follows:

`GPIB::<address>[:INSTR]`

GPIB                   = denotes the used interface  
<channel address> = the used channel  
[:INSTR]               = indicates the instrument resource class (optional)

**Note:** If the VISA implementation supports the GPIB interface, you can optionally define the VISA Instrument Control Resource (INSTR). It is used to define the basic operations and attributes for a device, such as reading, writing, or triggering.

### Notes and characteristics

In connection with the GPIB interface, note the following:

- Up to 15 instruments can be connected.
- The total cable length is restricted to a maximum of 15 m, or 2 m times the number of devices, whichever is less. The maximum recommended cable length between two instruments is 2 m.
- A wired "OR"-connection is used if several instruments are connected in parallel, since the slowest instrument determines the speed.
- Any connected IEC bus cable must be terminated by an instrument or controller.

## 13.2.4 LXI Browser Interface

The LXI browser interface allows easy configuration of the LAN and remote control of the R&S SMA100B without additional installation requirements. The instrument's LXI browser interface works correctly with all W3C compliant browsers.

See [Chapter 13.10.1, "LXI Functionality"](#), on page 430 for more about LXI.

The LAN settings are configured using the instrument's LXI browser interface described in [Chapter 13.5.2.1, "LAN Configuration"](#), on page 395. The LXI status settings in the R&S SMA100B are described in [Chapter 13.5.1, "LXI Status Settings"](#), on page 392.

## 13.3 Remote Control Programs and Libraries

This section shows how the remote-control programs access the instrument, and the libraries they require for the appropriate interface protocols.

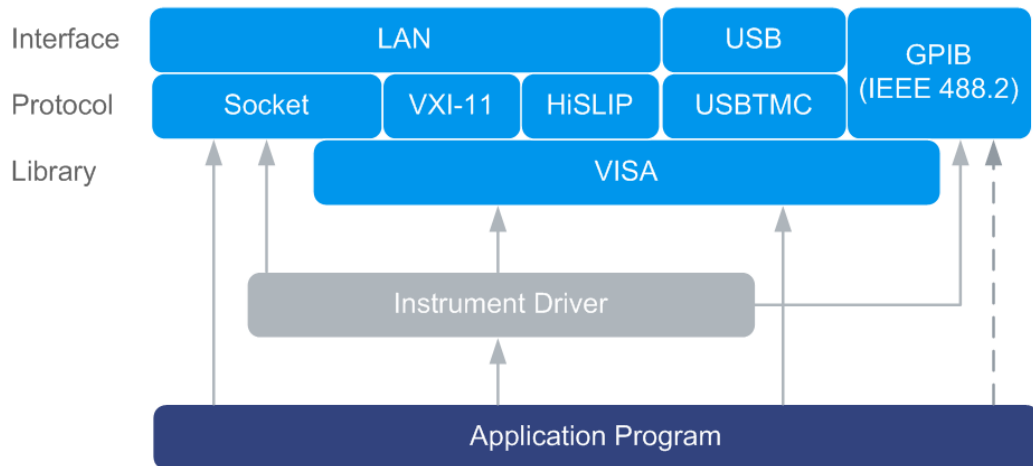

Figure 13-2: Overview of remote control interfaces, protocols and libraries

### 13.3.1 VISA Library

VISA is a standardized software interface library providing input and output functions to communicate with instruments. Thus, you can configure the interface without having to adjust the application program to the used interface.

The I/O channel (LAN or TCP/IP, USB, GPIB, etc.) is selected at initialization time with the channel-specific address string ("VISA resource string"), or by an appropriately defined VISA alias (short name). See also [Table 13-2](#) for an overview.

Instrument access via VXI-11 or HiSLIP protocols is achieved from high level programming platforms using VISA as an intermediate abstraction layer. VISA encapsulates the low-level VXI or GPIB function calls and thus makes the transport interface transparent for the user.

A VISA installation is a prerequisite for remote control using the following interfaces:

- LAN interface using [HiSLIP Protocol](#)
- LAN interface using [VXI-11 Protocol](#)
- [USB Interface](#)

Instrument access via the LAN socket protocol or GPIB connections can be operated both, with or without the VISA library. See also [Chapter 13.2.1.4, "Socket Communication"](#), on page 376 and [Chapter 13.2.3, "GPIB Interface \(IEC/IEEE Bus Interface\)"](#), on page 377.

For more information about VISA library, refer to the user documentation.

### 13.3.2 Possible Setups and Access Functions

The following examples give an overview of dependencies between the available libraries, the possible interfaces and protocols, and whether an instrument driver is provided. The involved parts are **highlighted**. For more information, see the application note [1GP72: Connectivity of Rohde&Schwarz Signal Generators](#).

- Remote control (application) program using VISA

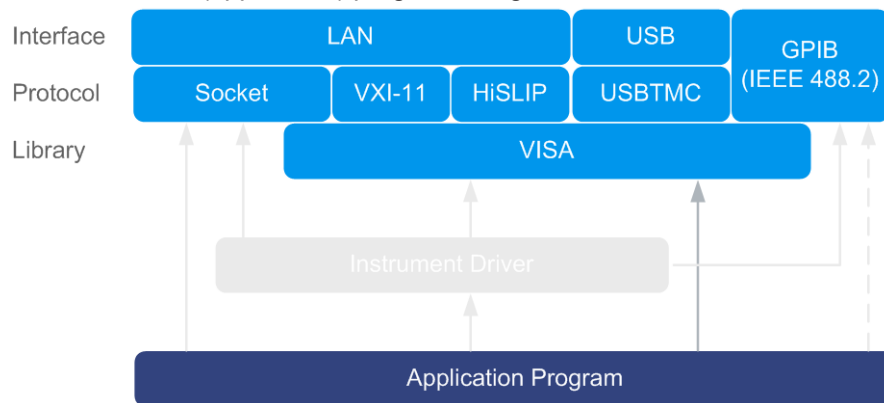

Figure 13-3: Application program using VISA

Protocol	Remote control program
Socket	<code>viOpen (... , "TCPIP:SMA100B-102030::5025::SOCKET", ...)</code> <code>viPrintf (... , "SOUR:FREQ 2GHz\n")</code>
VXI-11	<code>viOpen (... , "TCPIP:SMA100B-102030::inst0::INSTR", ...)</code> <code>viPrintf (... , "SOUR:FREQ 2GHz\n")</code>
HiSLIP	<code>viOpen (... , "TCPIP:SMA100B-102030::hislip0::INSTR", ...)</code> <code>viPrintf (... , "SOUR:FREQ 2GHz\n")</code>
USBTMC	<code>viOpen (... , "USB::0x0AAD::0x01DD::100001::INSTR", ...)</code> <code>viPrintf (... , "SOUR:FREQ 2GHz\n")</code>
GPIB	<code>viOpen (... , "GPIB::28::INSTR", ...)</code> <code>viPrintf (... , "SOUR:FREQ 2GHz\n")</code>

- Remote control program using instrument driver (VISA available)



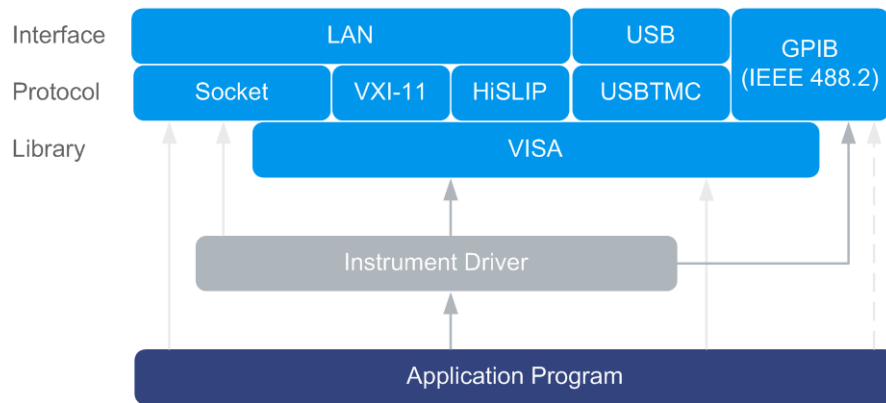

Figure 13-4: Application using instrument driver (VISA available)

Protocol	Remote control program
Socket	<code>rssma_init ("TCPIP:SMA100B-102030::5025::SOCKET", ...)</code> <code>rssma_SetFrequency (... , 2e9)</code>
VXI-11	<code>rssma_init ("TCPIP:SMA100B-102030::inst0::INSTR", ...)</code> <code>rssma_SetFrequency (... , 2e9)</code>
HiSLIP	<code>rssma_init ("TCPIP:SMA100B-102030::hislip0::INSTR", ...)</code> <code>rssma_SetFrequency (... , 2e9)</code>
USBTMC	<code>rssma_init ("USB::0x0AAD::0x01DD::100001::INSTR", ...)</code> <code>rssma_SetFrequency (... , 2e9)</code>
GPIB	<code>rssma_init ("GPIB::28::INSTR", ...)</code> <code>rssma_SetFrequency (... , 2e9)</code>

- Remote control program using instrument driver (VISA **not** available)

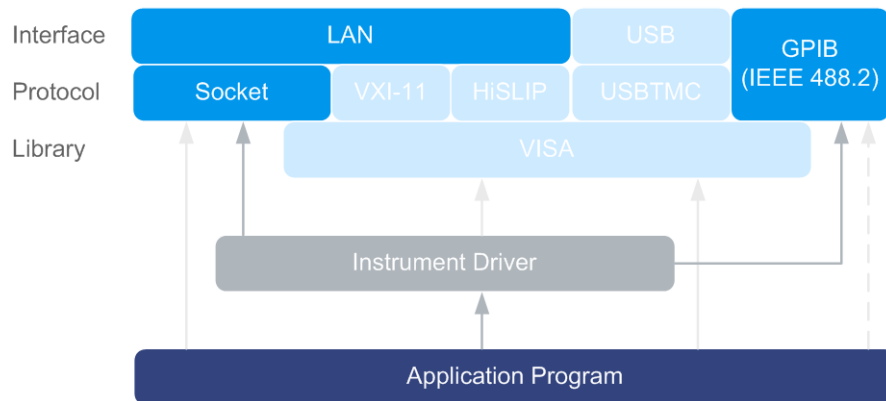

Figure 13-5: Remote control program using instrument driver (VISA not available)

Protocol	Remote control program
Socket	<pre>rssma_init ("TCPIP:SMA100B-102030::5025::SOCKET", ...) rssma_SetFrequency (... , 2e9)</pre>
GPIB	<pre>rssma_init ("GPIB::28::INSTR", ...) rssma_SetFrequency (... , 2e9)</pre>

## 13.4 Remote Access Settings

This section outlines the settings required for accessing and configuring the provided remote control interfaces. It includes network settings, access addresses, emulation settings for using the command sets of other generators, and the access via smart devices.

### About instrument emulations

You can also remotely control the R&S SMA100B via the command set of another signal generator. With this function you can, for example, replace a signal generator with an R&S SMA100B in an automated test setup, without adjusting the command scripts used.



The R&S SMA100B also covers command sets of Rohde & Schwarz signal generators. To achieve optimal compatibility when replacing an instrument, we recommend that you select the emulation command set for the corresponding signal generator.

You find all the remote control command sets supported by the R&S SMA100B in a selection list.

For more information, see the application note:

[1GP120: Remote Emulation with the R&S SMA100B Signal Generator.](#)

The selected instrument also defines the identification string that is retrieved with query `*IDN?`. If necessary, use the parameter `Mode` and `IDN String` to change this string.

As any other parameter, the remote control command set can also be changed remotely by the command `:SYSTEM:LANGuage`.

While working in an emulation mode, the R&S SMA100B specific command set is disabled and the SCPI command `:SYSTEM:LANGuage` is discarded.

To return to the SCPI command set of the R&S SMA100B, use the appropriate command of the selected command set.

If for example an HP generator is emulated, the HP command `EX` returns to the instrument-specific GPIB command set.

### 13.4.1 Network Settings

Access:

- ▶ Select "System Config > Remote Access > Network".

Net-work	Visa Res. Strings	GPIB Addr.	RS232	Instrument Emulations	Remote Connections	QR-Code	X
Network Status		Connected		Restart Network			
Instrument Name							
Hostname		Workgroup					
instrument		INSTRUMENT					
Instrument Address							
Address Mode		Auto (DHCP)					
IP Address		Subnet Mask		Default Gateway			
10.124.0.211		255.255.252.0		10.124.0.1			
DNS Suffix		DNS Server		MAC Address			
rsint.net		10.0.2.166		08 00 27 b7 82 49			

In the "Network" dialog, you can configure the settings of the general network environment and specific identification parameters of the instrument in the network.

The remote commands required to configure the network remotely are described in [Chapter 14.17, "SYSTem Subsystem"](#), on page 690.

How to: see [Chapter 13.6.3, "How To Connect to LAN"](#), on page 400.

#### Network Status

Indicates that the instrument is connected to the network.

Remote command:

`:SYSTem:COMMunicate:NETWork:STATus?` on page 702

#### Restart Network

Terminates the network connection of the instrument and subsequently sets it up again. You can use this function to fix network problems.

**Note:** This function restarts only the connection of the instrument to the network. It does not impact the network itself.

Remote command:

`:SYSTem:COMMunicate:NETWork:REStart` on page 702

### Hostname

Displays the hostname.

Each instrument is delivered with an assigned hostname, a logical name which can be used instead of the IP address. With the default network settings, the IP address is allocated by the DHCP server. This address can change each time the instrument is reconnected. Unlike the IP address, the hostname name does not change.

#### Note:

This function is password-protected. Unlock the protection level 1 to access it.

- We recommend that you do not change the default network settings or the host-name to avoid problems with the network connection.  
If you change the hostname, be sure to use a unique name.

Remote command:

`:SYSTem:COMMunicate:NETWork[:COMMON]:HOSTname` on page 702

### Workgroup

Sets the individual windows workgroup name of the R&S SMA100B. This parameter is required in case the instrument is integrated in a windows network.

This function is password-protected. Unlock the protection level 1 to access it.

Remote command:

`:SYSTem:COMMunicate:NETWork[:COMMON]:WORKgroup` on page 703

### Address Mode

Selects the mode for assigning the IP address.

How to: see [Chapter 13.6.4, "How to Assign the IP Address"](#), on page 400.

"Auto (DCHP)"

Assigns the IP address automatically, provided the network supports DHCP (Dynamic Host Configuration Protocol).

"Static"

Enables you to assign the IP address manually.

Remote command:

`:SYSTem:COMMunicate:NETWork:IPAddress:MODE` on page 701

### IP Address

Displays the IP address of the instrument in the network.

By default, the R&S SMA100B is configured to use dynamic TCP/IP configuration and to obtain the whole address information automatically.

If the network does not support DHCP or the attempt does not succeed, the instrument tries to obtain the IP address via Zeroconf (APIPA) protocol. IP addresses assigned via Zeroconf start with the number blocks 169.254.\*.\*.

**Note:** An IP address that is assigned via the Zeroconf protocol although the network requires an IP address assigned via the DHCP server can cause network connection failures.

See [Chapter 15.5, "Resolving Network Connection Failures"](#), on page 729.

How to:

- ["To assign the IP address manually on the instrument"](#) on page 401.
- [Chapter 13.6.2, "How To Activate LAN Services"](#), on page 400.

Remote command:

`:SYSTem:COMMunicate:NETWork:IPAdDress` on page 700

### Subnet Mask

Displays the bit group of the subnet in the host identifier.

To assign the subnet mask manually, select **Address Mode** > "Static".

Remote command:

`:SYSTem:COMMunicate:NETWork[:IPAdDress]:SUBNet:MASK` on page 703

### Default Gateway

Displays the gateway address.

This address identifies the router on the same network as the instrument that is used to forward traffic to destinations beyond the local network.

To assign the gateway address manually, select **Address Mode** > "Static".

Remote command:

`:SYSTem:COMMunicate:NETWork[:IPAdDress]:GATeway` on page 703

### DNS Suffix

Displays the primary DNS (Domain Name System) suffix, that means the DNS name without the hostname part.

The DNS system uses the suffix for registration and name resolution for unique identification of the instrument in the entire network.

To assign the DNS suffix manually, select **Address Mode** > "Static".

Remote command:

`:SYSTem:COMMunicate:NETWork[:COMMON]:DOMain` on page 702

### DNS Server

Determines the preferred server for name resolution. The DNS server contains the underlying numerical values that are required for name resolution of the hostname as part of the IP address.

To select the DNS server manually, select **Address Mode** > "Static".

Remote command:

`:SYSTem:COMMunicate:NETWork[:IPAdDress]:DNS` on page 703

### MAC Address

Indicates the MAC (Media Access Control) address, a unique identifier of the network adapter in the R&S SMA100B.

Remote command:

`:SYSTem:COMMunicate:NETWork:MACaddress` on page 701

## 13.4.2 VISA Resource Strings

Access:

- ▶ Select "System Config > Remote Access > VISA Resource Strings".

Network	Visa Res. Strings	GPIB Addr.	RS232	Instrument Emulations	Remote Connections	QR-Code	✕
HISLIP	TCPIP::10.124.1.233::hislip0::INSTR						
VXI11	TCPIP::10.124.1.233::inst0::INSTR						
Socket	TCPIP::10.124.1.233::5025::SOCKET						
GPIB	GPIB::28::INSTR						
USB	USB::0x0AAD::0x01dd::000000::INSTR						
SERIAL	ASRL1::INSTR						

The "Visa Resource String" dialog displays the VISA resource strings provided for remote control via the different interfaces.

#### Remote command:

:SYSTem:COMMunicate:HISLip:RESource? on page 700

:SYSTem:COMMunicate:NETWork:RESource? on page 701

:SYSTem:COMMunicate:SOCKet:RESource? on page 704

:SYSTem:COMMunicate:GPIB:RESource? on page 700

:SYSTem:COMMunicate:USB:RESource? on page 705

:SYSTem:COMMunicate:SERial:RESource? on page 704

### 13.4.3 GPIB Address Settings

Access:

1. Select "System Config > Remote Access > GPIB Address".

Network	Visa Res. Strings	GPIB Addr.	RS232	Instrument Emulations	Remote Connections	QR-Code	✕
GPIB Channel Address		28					

- Set the GPIB channel address of the connected instrument.

**Remote command:**

`:SYSTem:COMMunicate:GPIB[:SELF]:ADDRes` on page 700

### 13.4.4 RS232 Settings

Access:

- ▶ Select "System Config > Remote Access > RS232".

Network	Visa Res. Strings	GPIB Addr.	RS232	Instrument Emulations	Remote Connections	QR-Code	X
Needs USB Adapter (R&S TS1-USB)							
Baud Rate		Parity		Stop Bits			
115200		None		1			

The "RS232" dialog enables you to control the instrument over a serial interface using a USB adapter. The controller and the instrument must be connected with the external USB/serial-adapter R&S TS1-USB (see recommended extras in the data sheet) and a serial crossover (null modem) cable. The USB connection requires the Visa library to be installed on the controller. Visa detects and configures the R&S SMA100B automatically when the USB connection is established.

The remote commands required to configure the emulation settings remotely are described in [Chapter 14.17, "SYSTem Subsystem"](#), on page 690.

**Baud Rate**

Sets the baudrate for the serial remote control interface.

Remote command:

`:SYSTem:COMMunicate:SERial:BAUD` on page 703

**Parity**

Sets the parity for the serial remote control interface.

Remote command:

`:SYSTem:COMMunicate:SERial:PARity` on page 704

**Stop Bits**

Sets the number of stop bits for the serial remote control interface.

Remote command:

`:SYSTem:COMMunicate:SERial:SBITs` on page 704

### 13.4.5 Instrument Emulations Settings

Access:

- ▶ Select "System Config > Remote Access > Instrument Emulations".

The "Instrument Emulations" dialog enables you to emulate a remote control command set of another signal generator.

The remote commands required to configure the emulation settings remotely are described in [Chapter 14.17, "SYSTEM Subsystem"](#), on page 690.

#### Language

Selects the instrument whose remote command set is emulated by the R&S SMA100B.

Remote command:

[:SYSTEM:LANGUage](#) on page 707

#### Mode

Selects the way the instrument identification is performed.

"Automatic" Sets the "IDN String" and the "OPT String" automatically for the instrument selected with the parameter [Language](#).

"User Defined" Enables you to define the "IDN String" and the "OPT String".

Remote command:

[:SYSTEM:IDENTification](#) on page 705

#### Set to Default

In "Mode > User Defined", resets the \*IDN and \*OPT strings.



Remote command:

`:SYSTem:IDENtification:PRESet` on page 706

### IDN String

Indicates the identification string of the instrument when queried with the common command `*IDN?`.

In addition to the preset values, you can define your own identification string so that each generator uses an individual identification, like `My_SigGen` for instance, see [Mode](#) .

Remote command:

`*IDN?` on page 436

`:SYSTem:IRESpOnse` on page 706

### OPT String

Indicates the option string of the instrument as queried with common command `*OPT?`.

In [Mode](#) > "User Defined", you can define your own option string, additionally to the automatically created one.

Remote command:

`*OPT?` on page 437

`:SYSTem:ORESpOnse` on page 706

## 13.4.6 Remote Connections Settings

The "Remote Connections" dialog covers the active SCPI and TCP/IP connections, and a history list of the connections that have accessed the instrument before.

### 13.4.6.1 Active Connections

Access:

- ▶ Select "System Config > Remote Access > Remote Connections > Active".

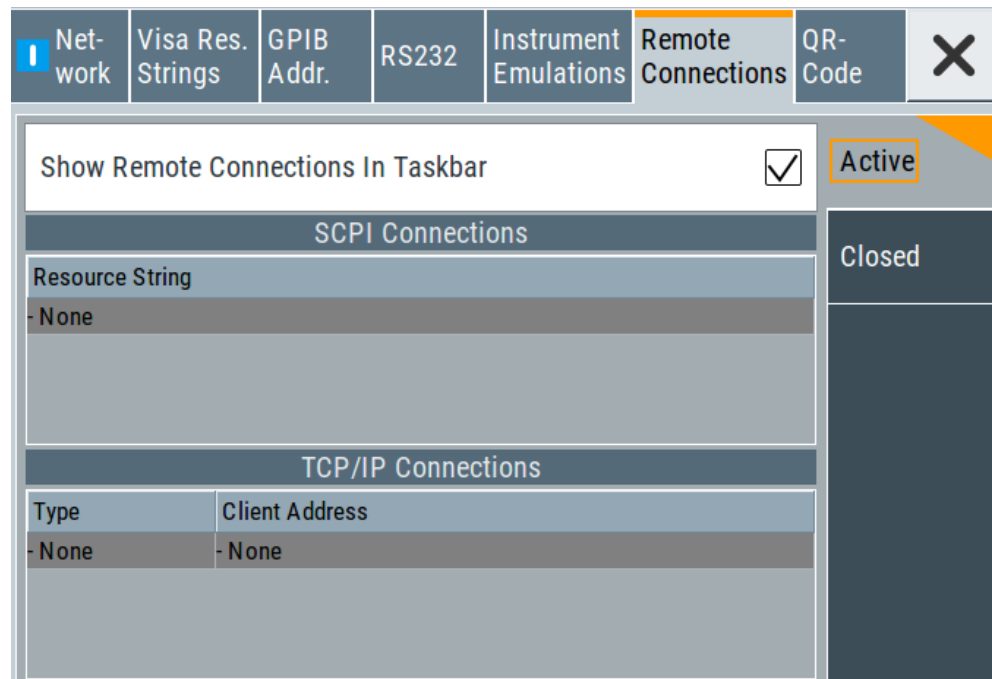

The "Active " tab shows the currently active remote connections, and you can enable the display of the active connections in the task bar.

#### Show Remote Connections in Taskbar

Displays the currently active connections in the taskbar.

#### SCPI Connections

Displays the VISA resources strings of the remote connections currently controlling the instrument via the LAN interface.

Remote command:

n.a.

#### TCP/IP Connections

Displays the types and client addresses of the remote connections currently controlling the instrument via the LAN interface.

Remote command:

n.a.

#### 13.4.6.2 Closed Connections

Access:

- ▶ Select "System Config > Remote Access > Remote Connections > Closed".

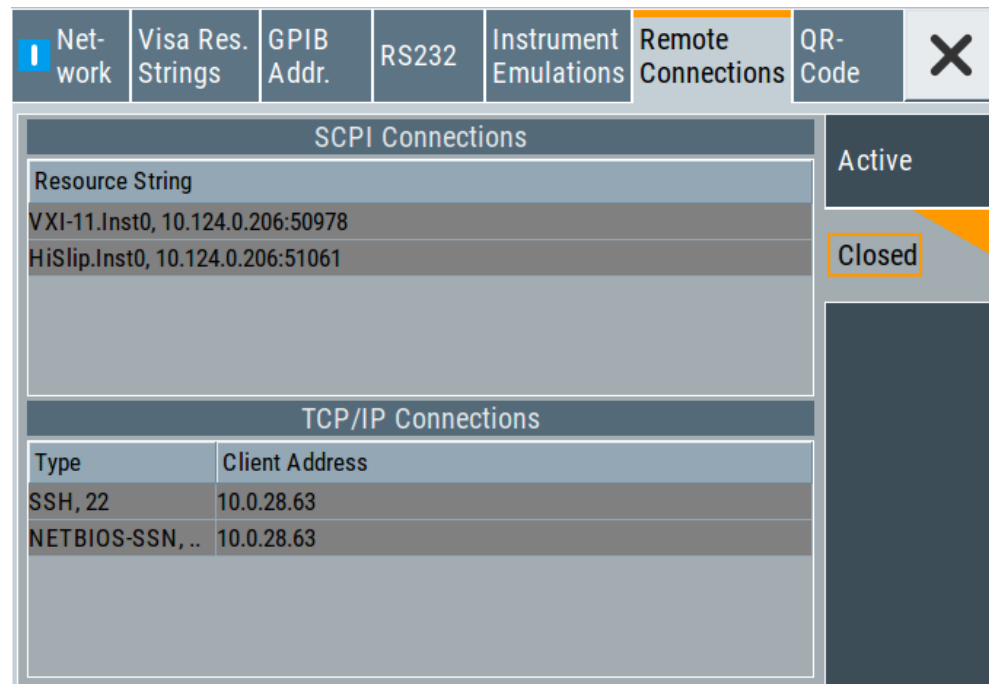

The "Closed" tab shows the currently active remote connections, and you can enable the display of the active connections in the task bar.

#### SCPI Connections

Lists the VISA resource strings of the last remote connections that have accessed the instrument via the LAN interface before.

Remote command:

n.a.

#### TCP/IP Connections

Lists the types and client addresses of the last remote connections that had accessed the instrument via the LAN interface before.

Remote command:

n.a.

### 13.4.7 QR Code

Access:

- ▶ Select "System Config > Remote Access > QR Code".



The "QR Code" dialog shows the current instrument address (IP address) in quick response (QR) format.

This functionality provides fast access to the instrument via VNC with, for example, a smartphone or a tablet.

See [Chapter 13.9.3, "How To Set Up a Remote Operation from a Smart Device"](#), on page 427.

## 13.5 LXI Settings

On the R&S SMA100B the LXI functionality is already installed and enabled, see [LXI Status Settings](#). Thus, the instrument can be accessed via any web browser (like the Microsoft Internet Explorer) to perform the following tasks:

- Modifying network configurations
- Remote control the instrument
- Performing SCPI remote diagnostics

The LAN settings are configured using the instrument's LXI browser interface described in [Chapter 13.5.2.1, "LAN Configuration"](#), on page 395.

### 13.5.1 LXI Status Settings

Access:

- ▶ Select "System Config > Setup > Remote Access > LXI Status...".

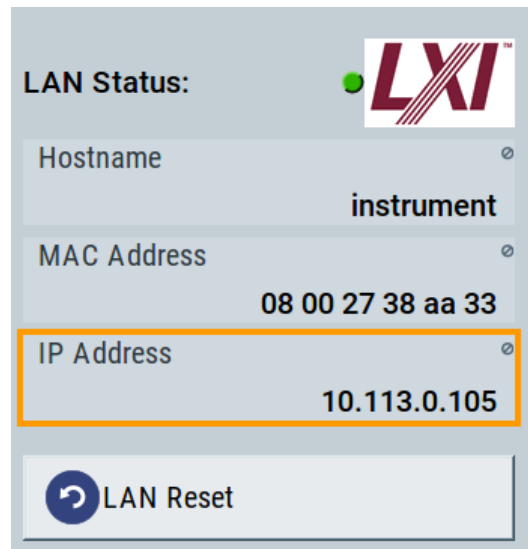

The "LXI - Status" dialog shows the parameters of the LAN connection.

Alternatively, you can change the LAN settings using the LXI web browser interface, see [Chapter 13.5.2.1, "LAN Configuration"](#), on page 395.

### LAN Status

The LED indicates the LXI status.

"green"	Normal operation
"green (flashing)"	Device identification
"red"	LAN fault

### Hostname / MAC Address / IP Address

See ["Hostname"](#) on page 384.

### LAN Reset

Initiates the network configuration reset mechanism for the instrument and resets the hostname, MAC address, and IP address.

According to the LXI standard, a LAN reset must place the following network settings to a default state:

Parameter	Value
TCP/IP mode	DHCP + Auto IP address
Dynamic DNS	Enabled
ICMP ping	Enabled
Password for LAN configuration	LxiWebIfc

The LAN reset also resets the following parameters for the Signal Generator:

Parameter	
Hostname	Instrument-specific hostname
Description	Vector signal generator
Negotiation	Auto detect
VXI-11 discovery	Enabled

### 13.5.2 LXI Browser Settings

To access the instrument via the web browser:

- ▶ In the address field of the browser on your PC, type the instrument's host name or IP address, for example *http://10.113.1.151*.

**Note:** Do not add the missing zeros in the IP address, while opening the instrument homepage.

The instrument homepage (welcome page) opens.

The navigation pane of the browser interface contains the following elements:

- "LXI"
  - "Home" opens the instrument homepage.  
The homepage displays the device information required by the LXI standard, including the VISA resource string in read-only format.
  - "Device Indicator" activates or deactivates the LXI status indication.  
When activated, the LXI LEDs flash, both in the browser dialog and in the LXI dialog of the connected instrument, see [LAN Status](#). A green LXI status symbol indicates that a LAN connection has been established; a red symbol indicates that no LAN cable is connected.
  - "Lan Configuration" allows you to configure LAN parameters and to initiate a ping, see ["Ping Client"](#) on page 397.
  - "Status" displays information about the LXI status of the instrument.
  - "Utilities" provides access to the LXI event log functionality required by the LXI standard.
- "Instrument Control"
  - "Web Control" provides remote access to the instrument, see ["Starting a remote control via the LXI web browser"](#) on page 404.
- "Diagnostics"
  - "SCPI Remote Trace" records messages exchanged via the remote control interface, see ["SCPI Remote Trace"](#) on page 397.
- "Help"
  - "Glossary" explains terms related to the LXI standard.
  - [www.rohde-schwarz.com](http://www.rohde-schwarz.com) opens the Rohde & Schwarz homepage.
- "Data Sheet"
  - Provides the data sheet with the specification data of the instrument at the time of delivery, see ["Data Sheet"](#) on page 399.

### 13.5.2.1 LAN Configuration

The "LAN Configuration" web page displays all mandatory LAN parameters and allows their modification.

It comprises the following navigation entries.

- [IP Configuration](#)..... 395
- [Advanced Config](#).....396
- [Ping Client](#).....397
- [SCPI Remote Trace](#)..... 397
- [Data Sheet](#)..... 399

### IP Configuration

The "IP configuration" web page displays all mandatory LAN parameters and allows their modification.

The screenshot displays the LXI LAN Parameters configuration interface. The left sidebar contains navigation links: Home, Lan Configuration (with sub-links for IP Configuration, Advanced Config, and Ping Client), Status, Utilities, Instrument Control (with sub-links for Web Control and Diagnostics), SCPI Remote Trace, Help (with sub-links for Glossary and www.rohde-schwarz.com), and Datasheet (with sub-link for Production Version). The main content area is titled 'LAN Parameters' and contains the following fields:

- Hostname: instrument
- DNS Hostname(s): instrument.rsint.net
- Domain: rsint.net
- Description: Instrument (FW version) Serial number
- IP Address Mode: DHCP + Auto IP Address (dropdown menu)
- IP Address: 10.113.1.151
- Subnet Mask: 255.255.252.0
- Default Gateway: 10.113.0.1
- Obtain DNS Server Address automatically:
- DNS Server(s): 10.0.2.166
- Register Device at DNS Server dynamically:

Additional notes include: 'Attention! Changing the hostname reboots the device!' and a password field labeled '(Password required)'. A 'Submit' button is located below the DNS Server(s) field. At the bottom, a 'Status' section shows 'No error' and a copyright notice: '© 2016 ROHDE&SCHWARZ. All rights reserved.'

The "IP Address Mode" selects a configuration mode for the IP address of the instrument. With static configuration, the entered IP address, subnet mask, and default gateway are used. With dynamic configuration, DHCP or dynamic link local addressing (automatic IP) is used to obtain the instrument IP address.



### Changing the LAN configuration

This function is password-protected. Unlock the protection level 1 to access it.

**Note:** We recommend that you change the default password before connecting the instrument to a network.

How to:

- ["Changing the default user password of the instrument"](#) on page 366.
- ["Changing the default security password"](#) on page 366.

See [Chapter 12.4.4, "Password Management"](#), on page 363.

### Advanced Config

The "Advanced Config" web page provides LAN settings that are not declared mandatory by the LXI standard.

The screenshot shows the LXI web interface. The top navigation bar includes the Rohde & Schwarz logo and the LXI logo. The main content area is titled "LAN Parameters" and contains the following settings:

- mDNS and DNS-SD:** A dropdown menu currently set to "mDNS & DNS-SD".
- ICMP Ping enabled:** A checkbox that is currently unchecked.
- VXI-11 Discovery:** A checkbox that is currently unchecked.

Below these settings is a "Submit" button and a password input field with the label "(Password required)".

At the bottom of the page, there is a "Status" section indicating "No error" and a copyright notice: "© 2016 ROHDE&SCHWARZ. All rights reserved."

The following advanced parameters are available:

- **"mDNS and DNS-SD":** The additional protocols "multicast DNS" and "DNS service discovery" are used for device communication in zero configuration networks, working without DNS and DHCP.
- **"ICMP Ping":** Must be enabled to use the ping utility. If you disable this setting, the instrument does not answer ping requests. The setting does not affect the LXI ping client. You can ping other hosts from the instrument, even if the setting is disabled.
- **"VXI-11 Discovery":** Must be enabled to detect the instrument in the LAN. If you disable this setting, the instrument cannot be detected by the VXI-11 discovery protocol mechanism. The setting does not affect other detection mechanisms. Setting up a VXI-11 connection via the IP address or the host name is independent of this setting.





### Changing the LAN configuration

This function is password-protected. Unlock the protection level 1 to access it.

**Note:** We recommend that you change the default password before connecting the instrument to a network.

How to:

- ["Changing the default user password of the instrument"](#) on page 366.
- ["Changing the default security password"](#) on page 366.

See [Chapter 12.4.4, "Password Management"](#), on page 363.

### Ping Client

The "Ping Client" page provides the ping utility to verify the connection between the LXI-compliant instrument and another device.

The ping is initiated from the instrument. Using the `ICMP` echo request and echo reply packets, this function checks whether the communication with a device via LAN is working. Ping is useful for the diagnosis of IP network or router failures.

To initiate a ping at the instrument:

1. On the "Ping Client" page, enter the IP address of the host in the "Destination Address" field (for example 10.113.1.151).
2. Select "Submit".

### SCPI Remote Trace

The remote trace functionality allows you to trace input and output strings at the remote control interface of the R&S SMA100B, see [Chapter 13.7.8, "How to Trace Messages with the LXI Web Browser Interface"](#), on page 413.

A recorded trace (message log) can be evaluated directly in the dialog. Use the highlighting and navigation functions provided by the lower toolbar to locate error messages and messages containing arbitrary search strings. You can also export the message log to a \*.CSV file and evaluate the file using a suitable program.

To trace and display messages, switch on "logging" and "live mode" in the toolbar.

### Toolbars

The toolbar at the top of the dialog provides basic settings and functions.

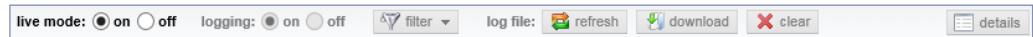

- "Live mode" / "logging": If logging is switched on, messages are traced. They are stored in an internal database and can be displayed upon request, using the refresh button (live mode off) or they can be displayed automatically (live mode on).
- "Filter": applies a filter to columns and/or rows when working (live mode off)
- "Refresh": reads the message log from the internal database and displays it
- "Download": stores the SCPI trace log to a \*.CSV file
- "Clear": deletes all message log entries in the database and at the screen
- "Details": displays details of the selected message, for example an SCPI command in hex format (also possible by double-clicking a message)

### Columns

The following columns are available if no column filter is applied:

- "Rec": record number of the message within the message log
- I: number of the subinstrument
- "MT": indicates the type of the message. Possible values and related message contents are:
  - > = incoming command
  - < = outgoing response to a query
  - E = error message, highlighted by red color
  - T = execution time, i.e. time required by the instrument to process the command internally.
- "message": indicates the type of the message. Possible values and related message contents are:
  - > = incoming command
  - < = outgoing response to a query
  - E = error message, denoted in red
  - T = execution time, i.e. time required by the instrument to process the command internally

## Data Sheet

The data sheet functionality allows you to retrieve the specification data of the instrument at the time of delivery.

The document contains all specified value ranges and information of the data sheet, for example important as reference values for recalibration.

The screenshot displays the 'Data sheet version' page in the R&S SMA100B web interface. The page title is 'Instrument Name Specifications Data sheet version'. Below the title, there is a brief description: 'This document contains all specified limits of the data sheet. These values can be used as reference values for recalibration. Examples for usage (SCPI) :system:spec? "ID\_RF\_FREQ\_SETTING\_TIME\_BX03\_BX06\_MS" or :syst:spec:par? "ID\_RF\_LEVEL\_MAX\_GENERAL\_FORMULA\_GHZ\_DBM",1.0 For details please see user manual.' Below this is a 'Contents' section with a table:

ID	Type	Value	ValueTypical	Formula
ID_RF_FREQ_SETTING_TIME_BX03_BX06_MS	ms			
ID_RF_FREQ_SETTING_TIME_BX12_BX20_MS	ms			
ID_RF_FREQ_SETTING_TIME_B131_B140_MS	ms			

The interface also shows a navigation menu on the left with options like Home, Lan Configuration, Status, Utilities, Instrument Control, Web Control, Diagnostics, SCPI Remote Trace, Help, Glossary, and Datasheet. The Datasheet section is currently selected, showing 'Production Version'. At the bottom, there is a 'Status' bar indicating 'No error' and a copyright notice: '© 2018 ROHDE&SCHWARZ. All rights reserved.'

## 13.6 Connecting the Instrument to the Network (LAN)

The R&S SMA100B is equipped with a network interface and can be connected to an Ethernet LAN (local area network).

There are two methods to establish a LAN connection to the instrument:

- A non-dedicated network (Ethernet) connection from the instrument to an existing network
- A dedicated network connection (Point-to-point connection) between the instrument and a single computer

For addressing, both the instrument and the computer require an IP address. The address information is usually assigned to the devices automatically, see [Chapter 13.6.4, "How to Assign the IP Address"](#), on page 400.

- [How To Enable Access via LAN](#).....400
- [How To Activate LAN Services](#).....400
- [How To Connect to LAN](#).....400
- [How to Assign the IP Address](#).....400
- [How to Use Computer Names \(Hostnames\)](#).....401

### 13.6.1 How To Enable Access via LAN

Per default, the LAN interfaces on the instrument are enabled.

If they have been disabled because of security reasons, enable them as follows:

1. Select "Setup > Security > LAN Services > LAN Interface = On".
2. Enter the [Security Password](#).
3. Select "Accept".

### 13.6.2 How To Activate LAN Services

Per default, the LAN interfaces and all LAN services are enabled.

If they have been disabled because of security reasons, enable them as follows:

1. Select "Setup > Security > LAN Services".
2. Enable the required service, e.g. "LAN Services > FTP > On".
3. Enter the [Security Password](#).
4. Select "Accept".

See [Chapter 12.4.5, "How to Prevent Unauthorized Access"](#), on page 365.

### 13.6.3 How To Connect to LAN

1. **NOTICE!** Connecting to the network can cause network failure. Errors can affect the entire network.

Consult your network administrator before performing the following tasks:

- Connecting the instrument to the network
- Configuring the network
- Changing IP addresses

2. Connect the LAN socket on the rear panel via an RJ-45 cable to the LAN.

The R&S SMA100B displays its IP address on the screen.

### 13.6.4 How to Assign the IP Address

Depending on the network capacities, the TCP/IP address information for the instrument can be obtained in different ways.

- If the network supports DHCP (dynamic host configuration protocol), the address information is assigned automatically.

- If the network does not support DHCP, the instrument tries to obtain the IP address via Zeroconf (APIPA) protocol. If this attempt does not succeed or if the instrument is set to use alternate TCP/IP configuration, the addresses must be set manually.

Since the dynamic TCP/IP configuration assigns the address information automatically, it is safe to establish a physical connection to the LAN without any previous instrument configuration.

#### To assign the IP address manually on the instrument

1. **NOTICE!** Connecting to the network can cause network failure. Errors can affect the entire network.

Consult your network administrator before performing the following tasks:

- Connecting the instrument to the network
- Configuring the network
- Changing IP addresses

2. Select "System Config > Remote Access > Network".

3. Select "Address Mode > Static".

4. Select the "IP Address".

5. Enter the IP address, for example *192.168.0.1*.

The IP address consists of four number blocks separated by dots. Every block contains 3 numbers in maximum.

6. Select the "Subnet Mask" and enter the subnet mask, for example *255.255.255.0*.

The subnet mask consists of four number blocks separated by dots. Every block contains 3 numbers in maximum.

#### To assign the IP address manually on the computer

- ▶ Obtain the necessary information from your network administrator. If you use more than one LAN connector, you need separate address information for each connector.

For information on how to perform the configurations, refer to the documentation of the operating system the computer uses.

### 13.6.5 How to Use Computer Names (Hostnames)

In a LAN that uses a DNS server, each PC or instrument connected in the LAN can be accessed via an unambiguous computer name (*hostname*) instead of the IP address. The DNS server translates the hostname to the IP address. It is especially useful when a DHCP server is used, as a new IP address can be assigned each time the instrument is restarted.

Each instrument is delivered with an assigned computer name, that remains permanent as long as it is not explicitly changed.

The default computer name follows the syntax <INST>-<Serial Number>, where:

- <INST> is the short name of your instrument, as stated on the front panel.
- <Serial Number> is the individual serial number of the instrument.  
You can find the serial number at the rear panel of instrument. It is the third part of the device ID printed on the barcode sticker .



**Example:**

The default hostname of an R&S SMA100B with a serial number 102030 is SMA100B-102030.

**To query and change a computer name**

1. Select "System Config > Remote Access > Network".  
The computer name is displayed under "Hostname".
2. Select "System Config > Setup > Security > Protection".
3. Enable the "Protection Level 1".  
The default password is 123456.  
The parameter "Hostname" in the "Network" tab is now enabled for configuration.
4. Change the "Hostname".

## 13.7 Controlling the R&S SMA100B Remotely

This section shows you how to set up remote control connections over the available interfaces.

The following general prerequisites must be fulfilled:

- The instrument and the controller have to be connected with the suitable cable and switched on.  
See [Chapter 13.6, "Connecting the Instrument to the Network \(LAN\)"](#), on page 399.
- To operate the instrument via remote control, it must be addressed using the defined interface address.  
See:
  - [Chapter 13.2.1, "LAN Interface"](#), on page 374
  - [Chapter 13.2.2, "USB Interface"](#), on page 377
  - [Chapter 13.2.3, "GPIB Interface \(IEC/IEEE Bus Interface\)"](#), on page 377
  - [Chapter 13.7.1, "How to Find the VISA Resource String"](#), on page 403

- A remote control program must open a connection to the instrument, before it can send commands to and receive device responses from the instrument.

If security is a concern, see:

- Document instrument security procedures.
- [Chapter 12.4.5, "How to Prevent Unauthorized Access"](#), on page 365.
- [How to Find the VISA Resource String](#)..... 403
- [How to Change the GPIB Instrument Address](#).....404
- [Establishing a Remote Control Connection over the LXI Browser Interface](#).....404
- [Establishing a Remote Control Connection over LAN Using VXI-11 Protocol](#)..... 405
- [Establishing a Remote Control Connection over LAN Using Socket Communication](#)..... 410
- [Setting Up a Remote Control Connection over GPIB](#).....411
- [Setting Up a Remote Control Connection over USB](#).....412
- [How to Trace Messages with the LXI Web Browser Interface](#)..... 413
- [How to Return to Manual Operation](#).....413

### 13.7.1 How to Find the VISA Resource String

- ▶ Select "System Config > Remote Access > VISA Resource Strings".

Network	Visa Res. Strings	GPIB Addr.	RS232	Instrument Emulations	Remote Connections	QR-Code	X
HISLIP					TCPIP::10.124.1.233::hislip0::INSTR		
VXI11					TCPIP::10.124.1.233::inst0::INSTR		
Socket					TCPIP::10.124.1.233::5025::SOCKET		
GPIB						GPIB::28::INSTR	
USB					USB::0x0AAD::0x01dd::000000::INSTR		
SERIAL						ASRL1::INSTR	

The dialog shows all specified resource strings of the supported remote control interfaces.

**Note:** Using the RS232 serial interface via USB requires the USB serial adapter R&S TS-USB1.

### 13.7.2 How to Change the GPIB Instrument Address

Option: R&S SMAB-B86

To control the instrument remotely via the GPIB bus, it must be addressed using the GPIB address. The remote control address is factory-set to 28, but it can be changed if it does not fit in the network environment. For remote control, addresses 0 through 30 are allowed. The GPIB address is maintained after a reset of the instrument settings.

To set the GPIB address:

1. Select "System Config > Remote Access > GPIB Address".
2. Select "GPIB Channel Address" and enter a value between 0 and 30.



#### Risk of losing remote connection

If the remote access and network settings had been configured to values different to the default, executing a factory preset via remote control terminates the connection to the instrument.

### 13.7.3 Establishing a Remote Control Connection over the LXI Browser Interface

Via the LXI browser interface to the R&S SMA100B one or more users can control the instrument remotely from another PC without additional installation. Most instrument controls are available via the front panel simulation. File upload and download between the instrument and the remote PC is also available.

#### Starting a remote control via the LXI web browser

1. On the instrument, enable the LAN interface.  
See [Chapter 13.6.1, "How To Enable Access via LAN"](#), on page 400.
2. Connect the remote PC and the instrument in the same network.  
See [Chapter 13.6.3, "How To Connect to LAN"](#), on page 400.
3. On the remote PC, start a web browser that supports HTML5 (W3C compliant).
4. Enter the IP address of the R&S SMA100B in the browser's address bar.  
The R&S SMA100B's welcome page is displayed.
5. In the navigation pane, select "Instrument Control" > "Web Control".  
Remote access to the instrument requires the password. The default password is *instrument*.
6. Enter the password and confirm with the [Enter] key.  
After the connection is established, the current screen of the R&S SMA100B is displayed in the browser window.



7. Use the mouse cursor and keyboard to access the functionality of the instrument as you would directly perform on the instruments touchscreen and front panel.

### 13.7.4 Establishing a Remote Control Connection over LAN Using VXI-11 Protocol

In this example, the I/O software library R&S VISA from Rohde & Schwarz is used to set up a LAN remote control link and remotely control the R&S SMA100B. R&S VISA is running on a controller PC with Windows operating system. When the connection is set up, you can send commands to the instrument and receive the responses.

The remote control connection requires a VISA installation but no additional hardware on the controller PC. The LAN I/O channel is selected at initialization time using the VISA resource string (also referred to as "address string"). A VISA alias (short name) is used to replace the complete resource string. The host address is the R&S SMA100B's hostname or its IP address.

See also [Chapter 13.2.1, "LAN Interface"](#), on page 374.

#### Setting up the controller with R&S VISA

To remote control the R&S SMA100B, we use the R&S VISA Tester application. The application communicates via TCP/IP protocol.



The instrument is preconfigured for networks using DHCP (dynamic host configuration protocol). If this configuration is used, enter the computer name in the position of the IP address.

1. On the instrument:
  - a) Enable the LAN interface.  
See [Chapter 13.6.1, "How To Enable Access via LAN"](#), on page 400.
  - b) Enable "SCPI over LAN".  
See [Chapter 13.6.2, "How To Activate LAN Services"](#), on page 400.
2. On the controller (remote PC), install the R&S VISA program.  
See <http://www.rohde-schwarz.com/rsvisa> > "RS VISA Release Notes".
3. Connect the controller and the instrument in the same network (network cable).  
Switch them on.  
See also [Chapter 13.6.3, "How To Connect to LAN"](#), on page 400.
4. On the controller, start "R&S VISA > Tester 32bit" or "R&S VISA > Tester 64bit".

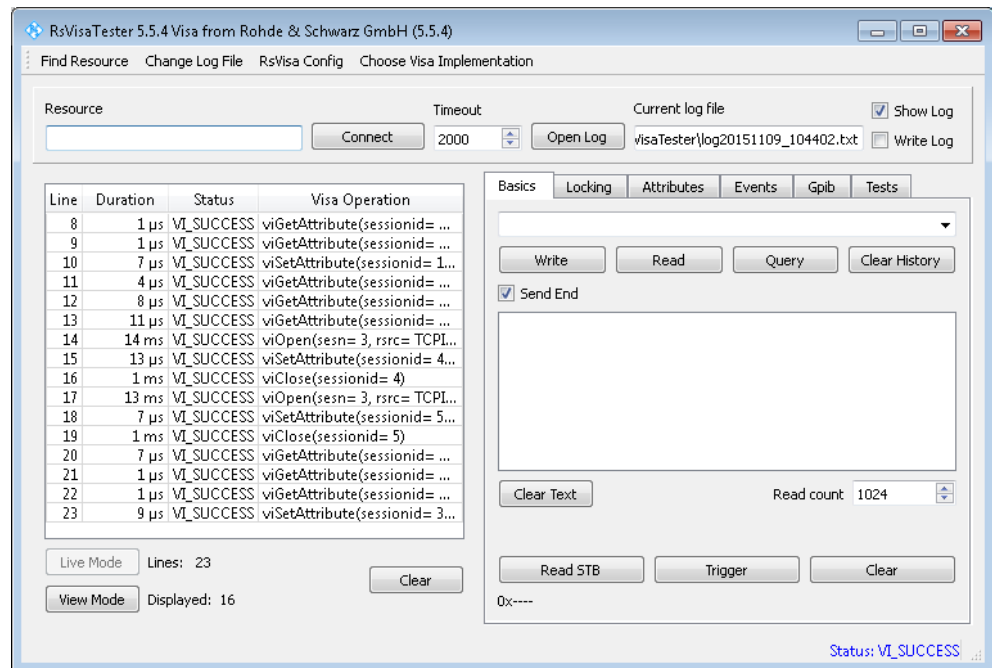

- In the menu bar, select "Choose VISA Implementation > Rohde & Schwarz Visa" and confirm with "OK".

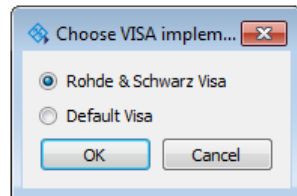

- In the menu bar, select "Find Resource" to search for the instrument in the LAN.

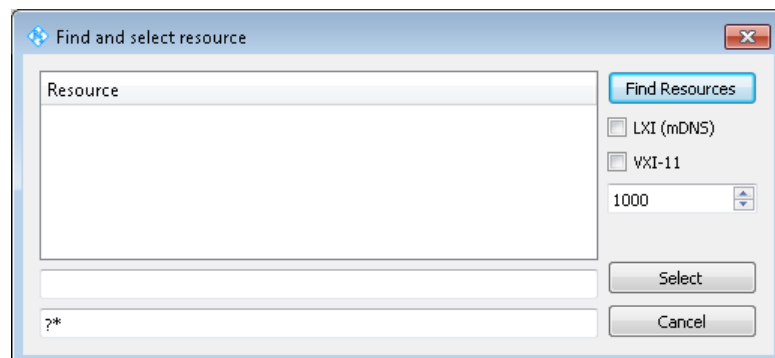

- Select "VXI-11" and "Find Resources".  
R&S VISA scans the network for connected instruments and lists all detected instruments in the "Resource" list.  
**Note:** The search may take some time, particularly in large networks.
- Select the required instrument and confirm with "Select".

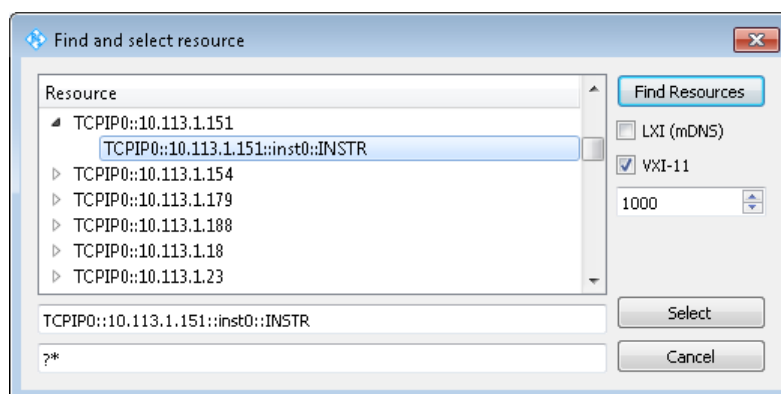

The "Find and select resource" dialog closes and R&S VISA indicates the IP address in the "Resource" field of the main application window.

9. As an alternative to the IP address, you can assign an alias name to the R&S SMA100B:

- a) In the menu bar, select "RsVisaConfig".

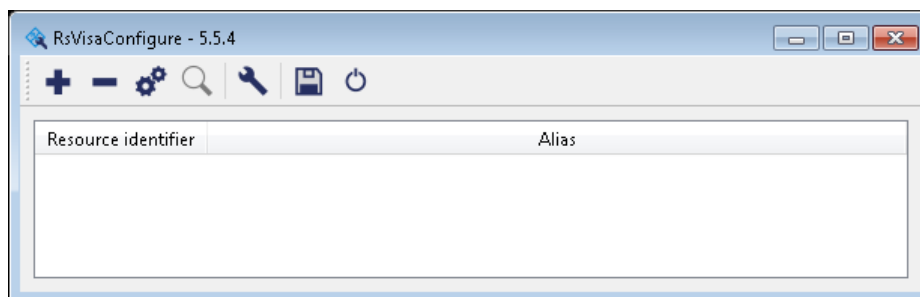

- b) In the toolbar, select "+" to access the "VISA Resource String Composer".

- c) Fill in the "Alias" name, the "VISA Resource String" and the "Device IP Address or host name" as shown in the figure, and confirm with "OK".

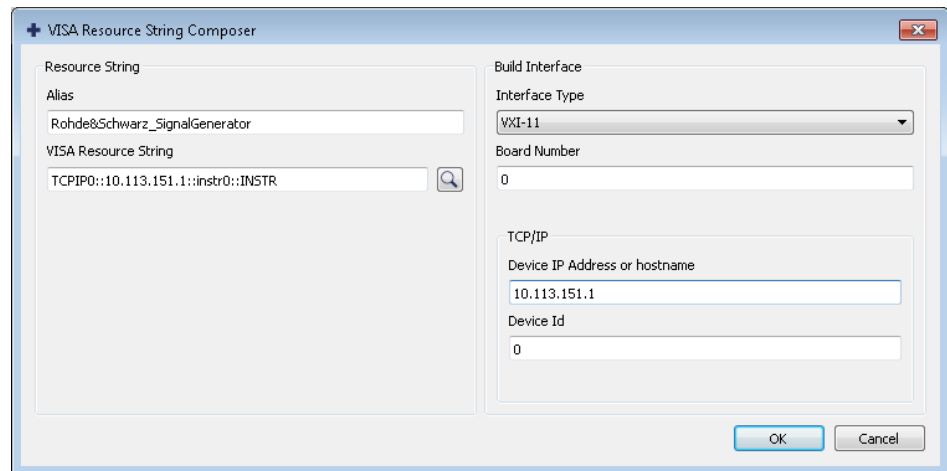

The "Alias" name is assigned.

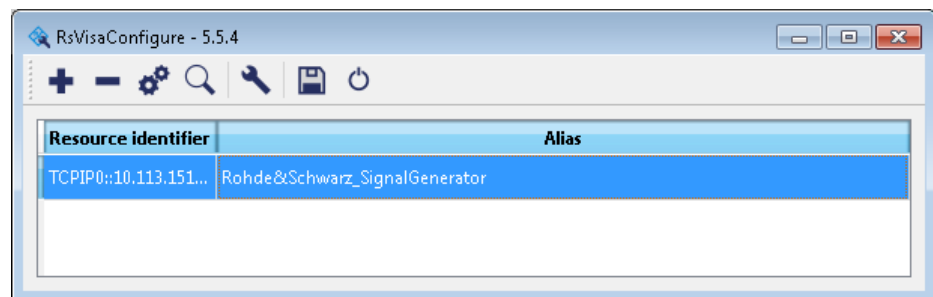

- d) Close the dialog.  
The R&S SMA100B is registered in the program. It can be addressed via the resource string or alias name.

10. In the main window, select "Connect".

R&S VISA establishes the connection to the R&S SMA100B.

You can send settings to configure the instrument and receive its responses.

**Note:** If the connection cannot be set up, R&S VISA displays an error in the log view.

See also [Chapter 15.5, "Resolving Network Connection Failures"](#), on page 729.

For further information on the functions to read and write to an open session, and the utility applications the software provides, see the R&S VISA user manual.

### Starting a remote control session over LAN with R&S VISA

To set the instrument to remote control, you can use the addressed command `&GTR` or send any command from the controller.

1. Start the R&S VISA Tester.  
Establish the connection to the R&S SMA100B.  
See ["Setting up the controller with R&S VISA"](#) on page 405.

- In the R&S VISA "Basics" tab, enter an SCPI command, e.g. "\*IDN?". Confirm with "Query".

The instrument is switched to remote control when it receives a command from the controller.

- Select "Read" to obtain the instrument response.

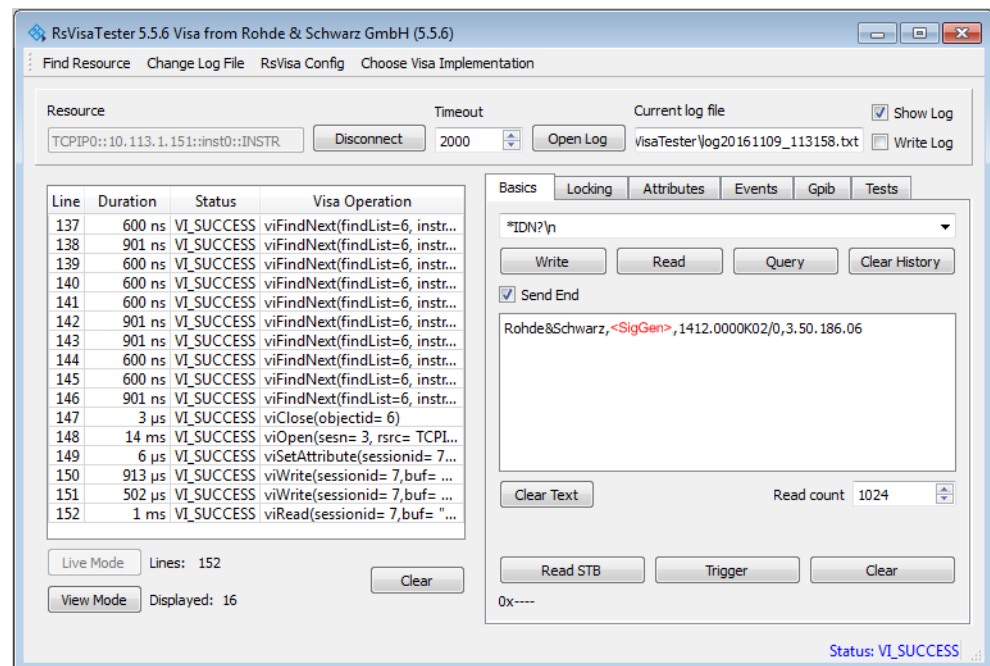

**Tip:** If the "Show Log" checkbox is checked, R&S VISA displays each VISA function call in the log-view on the left. If you check the "Write Log" checkbox, the log-view entry is written to the log file as well. You can operate the log-view in two modes: the "Live Mode" shows only the most recent messages whereas the "View Mode" allows you to scroll the history.

- To set, e.g. the frequency, enter `SOUR1:FREQ 4 GHz` and select "Write". To check the performed setting, `SOUR1:FREQ?` and select "Query". The instrument response is `4000000000`. The value corresponds to the frequency in Hz.

While remote control is active, the "Remote" icon in the status bar indicates that the instrument is in remote control mode. Currently ongoing communication (data transfer) is indicated by green colored arrows in the icon.

Operating via the front and touch panel or via mouse and keyboard are locked, allowing a remote control program to be performed without interruption. On the display, keys and entry fields are grayed out and cannot be activated or modified, but you can still open dialogs, for example to verify settings.

- To disable the access to the dialogs, use the command `SYST:KLOC ON`.
- To prevent unintentional return to manual operation, use the command `&LLO`. See also [Chapter A.1.2, "LAN Interface Messages"](#), on page 752.

The instrument switches to "Remote LLO" state. The [Setup] key is disabled.

7. To enable the [Setup] key, use the command `&GTR`.
8. To return to manual operation, see [Chapter 13.7.9, "How to Return to Manual Operation"](#), on page 413.

**Tip:** Switching from manual operation to remote control and vice versa does not affect the other instrument settings.

### 13.7.5 Establishing a Remote Control Connection over LAN Using Socket Communication

This section provides an example on how to establish a remote control connection over Telnet client and a simple sockets-based program example that can be further developed.

See also [Chapter A.2, "Telnet program examples"](#), on page 772.



The telnet client transmits information unencrypted. Therefore, for sensitive information we recommend that you use a client which supports secure protocols, like SSH.

In the following example, we assume basic knowledge of programming and operation of the controller. You can find information on the interface commands in the corresponding manuals.

#### Setting up a Telnet connection

To control the software, only a Telnet program is required. The Telnet program is part of every operating system.

1. On the instrument:
  - a) Enable the LAN interface.  
See [Chapter 13.6.1, "How To Enable Access via LAN"](#), on page 400.
  - b) Enable "SCPI over LAN".  
See [Chapter 13.6.2, "How To Activate LAN Services"](#), on page 400.
2. Connect the remote PC and the instrument in the same network.  
See also [Chapter 13.6.3, "How To Connect to LAN"](#), on page 400.
3. On the remote PC, start the Telnet program.  
Enter the socket address.  
The socket address is a combination of the IP address or the hostname of the R&S SMA100B and the number of the port configured for remote-control via Telnet.  
**Tip:** The R&S SMA100B uses the port number 5025 for remote connection via Telnet.

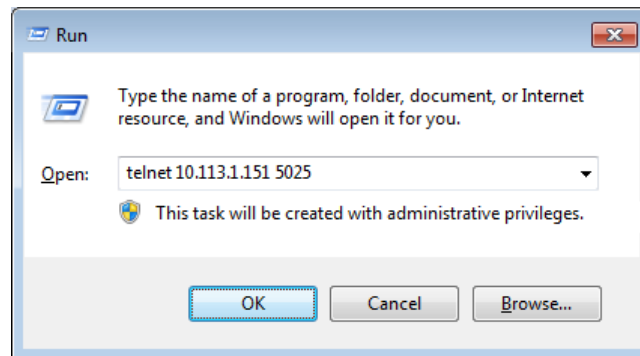

The connection to the instrument is set up and you can send remote-control commands.

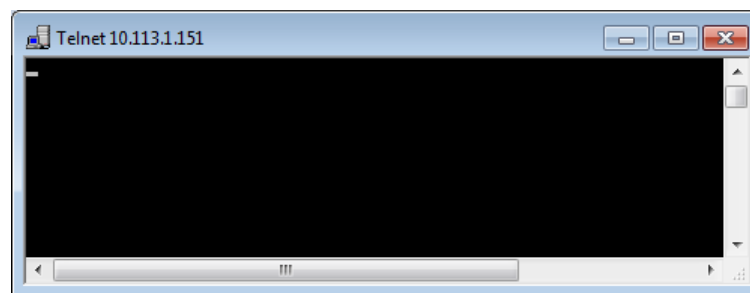

4. Telnet does not reflect your first entry. Insert a command, e.g. \*IDN and confirm with "Enter".
5. Observe the screen.  
A response on the query confirms that the connection is working. The client displays all subsequent inputs and responses.
6. Even if the cursor is not visible on the screen, blindly enter a remote-control command. Confirm with Enter.

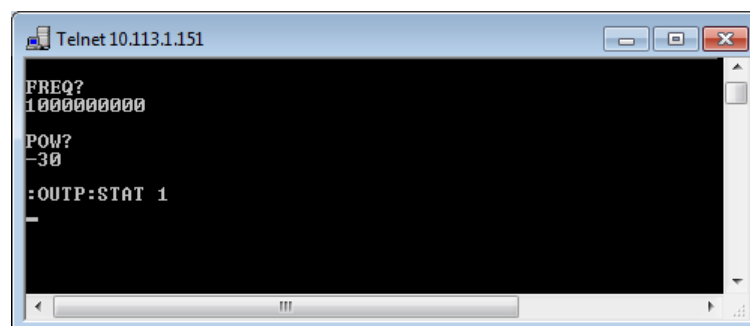

### 13.7.6 Setting Up a Remote Control Connection over GPIB

The program example in this section is written in VISUAL BASIC. A condition for programming in VISUAL BASIC is that the modules NIGLOBAL (Niglobal.bas) and VBIB32 (Vbib\_32.bas) are added to the projects.



Drivers for instrument, for example IVI-COM and LabVIEW drivers, are available for download area on the product page at:

<https://www.rohde-schwarz.com/driver/sma100b/>

### Starting a remote control session over GPIB

1. Connect instrument and controller using a GPIB cable. Switch them on.
2. Select "System Config > Remote Access > GPIB Address " > "**GPIB Channel Address = 28**".  
The GPIB address of the instrument must be the default value of 28.
3. Execute the following commands on the controller:
  - a) Open the port to the instrument.  
`CALL IBFIND("DEV1", generator%)`
  - b) Inform the controller about instrument address.  
`CALL IBPAD(generator%, 28)`
  - c) Reset the instrument.  
`CALL IBWRT(generator%, "*RST;*CLS")`
  - d) Set the instrument to new address.  
`CALL IBWRT(generator%, "SYST:COMM:GPIB:ADDR 18")`
  - e) Inform the controller about new address.  
`CALL IBPAD(generator%, 18)`

The GPIB address of the instrument is changed.
4. To return to manual operation, press the Local key at the front panel.

## 13.7.7 Setting Up a Remote Control Connection over USB

For remote control via the USB connection, the PC and the instrument must be connected via the USB type B interface. A USB connection requires the VISA library to be installed. VISA detects and configures the R&S instrument automatically when the USB connection is established. You do not have to enter an address string or install a separate driver.

### Starting a remote control session over USB

1. Connect instrument and controller using USB cable. Switch them on.
2. Execute the following commands on the controller:
  - a) Open the port to the instrument.  
`viOpen (... , "USB::0x0AAD::0x01DD::100001::INSTR", ...)`
  - b) Reset the instrument.  
`viRST(generator%, "*RST;*CLS")`
  - c) Set 2 GHz frequency  
`viPrintf (... , "SOUR:FREQ 2GHz\n")`



- d) Set 20 dBm output level

```
viPrintf (... , "SOUR:POW -20dBm\n")
```

The RF frequency and signal level of the instrument are changed.

3. To return to manual operation, press the [Local] key.

### 13.7.8 How to Trace Messages with the LXI Web Browser Interface

The remote trace functionality allows you to trace commands and messages exchanged via a remote control interface of the R&S SMA100B.

#### Activating the SCPI remote trace

1. On the instrument:
  - a) Enable the LAN interface.  
See [Chapter 13.6.1, "How To Enable Access via LAN"](#), on page 400.
  - b) Enable "SCPI over LAN".  
See [Chapter 13.6.2, "How To Activate LAN Services"](#), on page 400.
2. Connect the remote PC and the instrument in the same network.  
See also [Chapter 13.6.3, "How To Connect to LAN"](#), on page 400.
3. Start a web browser that supports HTML5 (W3C compliant).
4. Enter the IP address of the R&S SMA100B in the browser's address bar.  
The welcome page is displayed.
5. In the navigation pane, select "Diagnostics > SCPI Remote Trace".
6. In the toolbar bar of the "SCPI Remote Trace" page, select "live mode > on" and "logging > on".  
"live mode > on" displays all commands and responses, and "logging > on" also traces messages.

If you now control the R&S SMA100B with SCPI commands, using an appropriate tool, the LXI function records the information sent and received.

The function records all sent commands, received responses and messages, and saves them in an internal database. If "live mode" is disabled, you can display the recent traces upon request, using the "refresh" button. You can also save the log in a file.

**Note:** The diagnostics functionality will be extended in later releases, e.g. to download or upload SCPI command files from / to the instrument.

### 13.7.9 How to Return to Manual Operation



Before returning to manual control, command processing must be completed. Otherwise, the instrument switches back to remote control immediately.

1. To return from "Remote" state to manual state, perform one of the following:
  - On the controller, use the command `&GTL`

**Note:** If `&NREN` has been set before `&GTL` is locked. Use `&GTR` instead.
  - In the status bar, select the "Remote" icon.
  - On the front panel, press the [Local] key.
  - In the block diagram, select "Context sensitive menu > Key Emulation > Local"
2. To return from "Remote LLO" state to manual or to "Remote" state, perform one of the following:
 

**Note:** In the local lockout state, the command `&GTL` and the [Local] key are locked. You can unlock this state only via remote control.

  - On the controller, use the command `&LOCS`.  
This command switches directly to manual operation.
  - Send the command `&REMS`.  
This command changes the remote control state from "Remote LLO" to "Remote".
  - Use the Visual Basic command `CALL IBLOC (generator%)`.  
The command switches directly to manual operation.
  - VISA function `viGpibControlREN()`  
This function switches directly to manual operation.

## 13.8 Automating Tasks with Remote Command Scripts

To achieve fast configuration, make complex test setups or repeating measurements reproducible, you can automate the required settings with scripts. A script contains a series of SCPI commands corresponding to the settings. When completed, it is converted to an executable format, saved in a file and can be run whenever needed.



If you frequently need to load and run a script, assign the script to the [★ (User)], and you can quickly and easily perform the task.

See [Chapter 12.2.4, "How to Assign Actions to the \[★ \(User\)\] Key"](#), on page 348.

In contrast to "Recall Setup" via the [★ (User)] key, an assigned script execution does not close active dialogs and windows. On the contrary, even active window control (open / close) is possible.

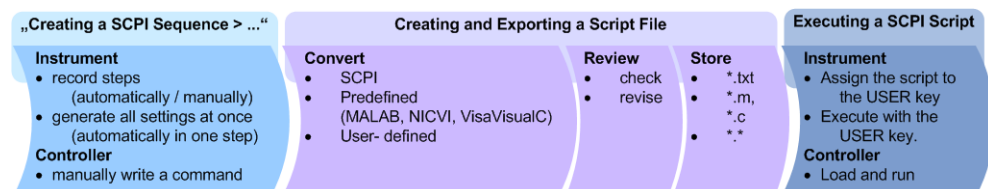

Figure 13-6: Steps for performing SCPI Scripts

In the graph, you can see the main steps required to work with an SCPI script.

### Creating a SCPI list

With the SCPI record functions, you can create a SCPI command list directly in the instrument and then export the list to the controller. If you want to edit or write a script manually, use a suitable editor on the controller. Even for manually creating, the instrument supports you by showing the corresponding command syntax and the current settings value.

Directly in the instrument, you can create a SCPI list at any time of operation, in the following ways:

- Recording steps

Both, automatic and manual SCPI recording of settings is possible. You can start, stop and resume automatic recording, and also record individual commands manually.

  - Manually record the steps selectively

In manual recording mode, you can deliberately record a SCPI command with the "Add CPI Command to Recording List" function, see [How to record SCPI lists manually](#).
  - Automatically record all performed steps

The instrument records the SCPI command and settings value of each step you perform, and then writes the commands to the file system, see [How to record SCPI lists automatically](#).  
You can also add a SCPI command manually to the recording list during automatic SCPI recording.

**Note:** The Signal Generator clears the SCPI list after booting automatically.
- Generating all settings at once

Generates the SCPI commands of the current instrument settings in one step, and writes the command list in a temporary list, see [How to create a SCPI list with the current instrument settings in one step](#).

**Note:** This function lists all commands in alphabetical order, in contrast to the recording or manual creation, which consider the order the settings are configured. Using this function can slow down the runtime or cause errors during execution. Therefore, always check and revise a script if necessary, see ["How to check an SCPI list"](#) on page 421.
- Manually create a command script with "Copy" and paste

Enables you to copy the SCPI command and the current setting, see [Chapter 13.8.1, "Show SCPI Command"](#), on page 417.



Some parameters cannot be set by an SCPI command.

If so, *no SCPI command found* is entered instead of a command when you record or generate all settings at once.

### The difference between Show SCPI Command and the provided cross-reference

If you want to enter your settings in a script, or use a remote control program, you must know the corresponding SCPI command and the exact syntax.

If you need to look up the SCPI command, the instrument offers two ways to figure it out quickly.

- "Show SCPI command" (context-sensitive menu)  
Displays the SCPI command syntax of a selected parameter including the current setting value, see ["Findig out the SCPI command using "Show SCPI Command" on page 423.](#)  
The "Copy" function enables you to write an SCPI script conveniently by hand.
- Instrument help ([Help] key)  
Opens a help topic that describes the selected parameter or instrument function, including a cross-reference to the corresponding SCPI command. The reference leads you to the description of the SCPI command comprising the complete SCPI syntax, all available setting values, value ranges, etc.  
See ["Findig out the SCPI command using the online help" on page 423.](#)

### Creating and exporting a script file

When the script list is completed, a code generator translates the SCPI commands into the source code of a proprietary programming language, using a code template. Therefore, each language requires an appropriate code template. When converted, you can save the script in a file with an extension corresponding to the programming language.

The R&S SMA100B provides the following predefined code templates by default:

- Plain SCPI  
Represents SCPI base format, that is ASCII format, saved as text file (\*.txt).
- MATLAB  
A programming environment, frequently used in signal processing and test and measurement applications (\*.m).  
You can directly use this format with MATLAB(c) Toolkit. For comprehensive information on this topic, refer to the application note [1GP60: MATLAB Toolkit for R&S Signal Generators.](#)
- NICVI  
An ANSI C programming environment designed for measurements and tests (\*.c).  
You can directly use this format with National Instruments LabWindows CVI.
- Python3  
A general purpose and high level programming language (\*.py).

You can also convert a script to a user-specific format. In this case, you need a code template with the extension \*.expcodetmpl.

For information on how to select the code template and save the script in a file, see [Chapter 13.8.3, "SCPI Recording Export Settings"](#), on page 418.

### Executing an SCPI script

An SCPI script primarily runs on the controller PC. In addition, you can execute a script directly on the instrument, by assigning the script to the [★ (User)] key.

See [Chapter 12.2.4, "How to Assign Actions to the \[★ \(User\)\] Key"](#), on page 348.

### 13.8.1 Show SCPI Command

Access:

1. Select the parameter.
2. Open the context-sensitive menu (tap and hold).
3. Select "Show SCPI Command".

This function provides the syntax of the remote command with the current setting.

#### Copy

Copies the command and the current setting.

#### Close

Exits the "SCPI Command" dialog.

### 13.8.2 Displaying an SCPI List

The instrument displays a recorded SCPI list and thus provides viewing the recorded results before exporting.

- ▶ Depending on the starting point, you can access the "SCPI Recording List" dialog as follows:
  - During recording  
Select "Show SCPI Recording List" in the context-sensitive menu.
  - At any time outside recording  
Select "Show SCPI Recording List" in the context-sensitive menu.  
This function assumes that at least one recording has been executed after power-on.
  - At the end of the recording  
Select "Stop automatic SCPI recording". The dialog opens automatically.
  - After you have exported the script to a file.  
Select "SCPI Recording Export > Show file content"  
See [Chapter 13.8.3, "SCPI Recording Export Settings"](#), on page 418.

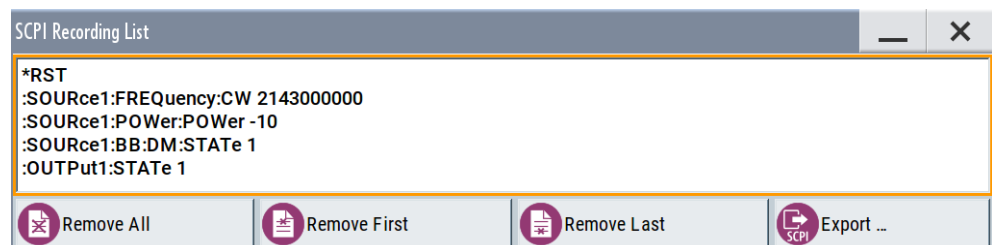

The "SCPI Recording List" shows the last recorded and exported commands.

**SCPI Recording List**

Lists the automatically or manually recorded recorded SCPI commands.

**Export**

Opens the [SCPI Recording Export](#) dialog for configuring the file parameters for export.

**Remove All, Remove First, Remove Last**

Deletes either the first, the last or all recorded SCPI commands.

To remove several recorded commands, repeat the removing.

For post processing, export the SCPI command list in a file, see [Chapter 13.8.5, "How to Convert and Save SCPI Lists"](#), on page 422.

**13.8.3 SCPI Recording Export Settings**

Scripts are configured and saved in the "SCPI Recording Export" dialog. This dialog opens automatically, when you stop recording.

Access:

1. Select "Show SCPI Recording List" in the context-sensitive menu.  
The "SCPI Recording List" dialog opens.
2. Select "Export".

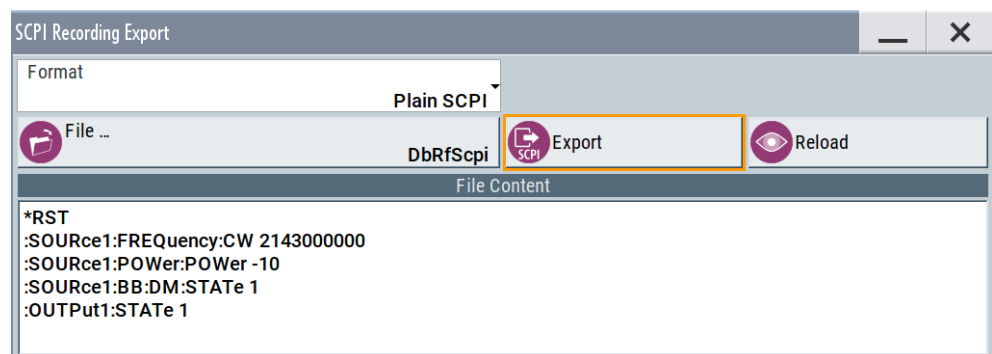

The "SCPI Recording Export" dialog contains all functions required for export of command lists to a file. It enables you to select the source code format, assign an individual filename and display the file content.

**Format**

Selects the source code format for the command list.

"Plain SCPI" Uses SCPI syntax.

"Predefined Code Generator"

Accesses the predefined templates for common source code generators that convert the recorded settings in the programming languages MATLAB or NICVI or Python.

"User Code Generator"

Use this setting to convert a script by a user-specific code generator.

**Select Code Template**

Opens the standard "File Select" dialog and lists the predefined or user-defined code templates.

See [Chapter 11.5.1, "File Select Settings"](#), on page 315.

**File**

Opens the standard file select dialog "Select Output File", see [Chapter 11.5.1, "File Select Settings"](#), on page 315.

**Export**

Executes data export.

The SCPI list is saved in as file with the selected filename and in the selected directory, see [File](#).

**Reload**

Reloads a SCPI list from a file.

You can export recorded SCPI lists to files (see [File](#) and [Export](#)), that can be modified.

**File content**

Displays the content of the script in the selected format and code template.

## 13.8.4 How to Record / Create SCPI Lists

**How to record SCPI lists automatically**

The following example briefly explains how to proceed when you want to record SCPI lists.

For comprehensive description, see [1GP98: SCPI Recorder Test Automation on a Fingertip](#).

1. On the screen, open the context-sensitive menu (touch and hold, or right mouse click) and select "Start SCPI recording".

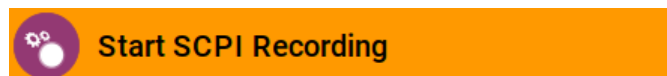

Starting from now, all steps you perform are recorded.

2. To stop SCPI recording, select "context-sensitive menu > Stop SCPI recording".



The "SCPI Recording List" dialog opens automatically.

3. Proceed with [How to check an SCPI list](#).

### How to record SCPI lists manually

1. To retrace your settings, open the context-sensitive menu and select "Mark all Parameters Changed from Preset".



**Mark All Parameters Changed from Preset**

This function identifies and highlights all settings you have changed, both in the block diagram, and in the dialogs.

Frequency	4.000 000 000 000 GHz	
Offset	10.000 000 kHz	Multiplier 1.000
User Variation		
Variation Active	<input checked="" type="checkbox"/>	Variation Step 1.000 000 000 MHz

2. For selectively recording your steps:
  - a) Set the parameter.
  - b) Open the context-sensitive menu.
  - c) Select "Add SCPI Command to Recording List"



**Add SCPI Command to Recording List**

**Tip:** You cannot see "Add SCPI ..." in the menu?

A possible reason is opening the menu outside of a dialog or input field, for example in a block diagram. Open the context-sensitive menu within the corresponding dialog or input field, and the feature is available.

- d) Continue with the next setting, and repeat steps *a to b* whenever needed.

Each time you select "Add SCPI ...", the SCPI command is appended to a temporary list.

3. To check the progress of the recording, select "Context-Sensitive > Show SCPI Recording List".



**Show SCPI Recording List (4)**

The "SCPI Recording List" dialog opens, displaying all recorded settings so far.

4. Proceed with [How to check an SCPI list](#).

### How to create a SCPI list with the current instrument settings in one step

You can also generate a SCPI list from a manually created instrument state at any time, in only one step.



To generate an SCPI list with commands for all settings performed:

1. Select "Save/Recall > SCPI Export".

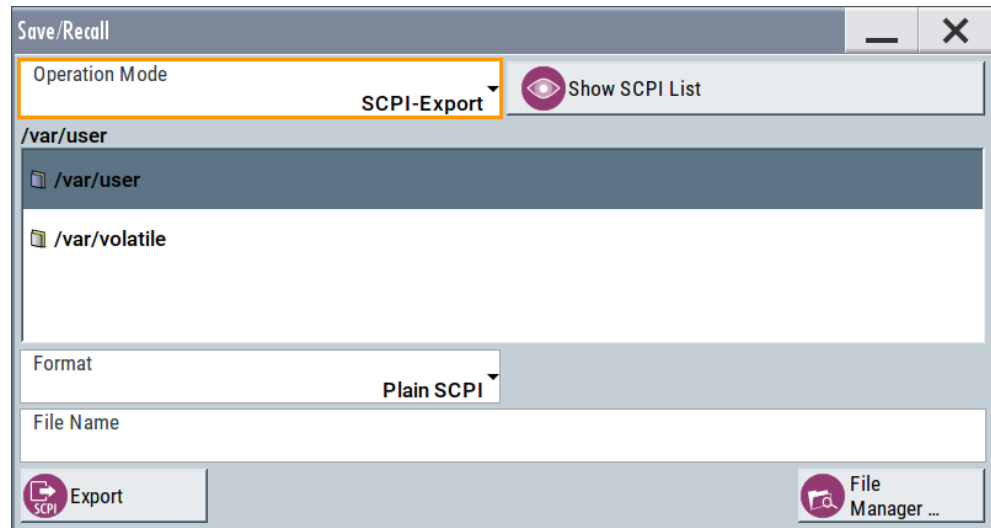

The instrument opens the standard file select dialog, see [Chapter 11.4.1, "Save/Recall Settings"](#), on page 311.

2. In the "Format" entry field, select the source code.
3. Depending on the selected format, convert the script as described in [Chapter 13.8.5, "How to Convert and Save SCPI Lists"](#), on page 422
4. Enter a filename.
5. Select "Export".  
The instrument writes all SCPI commands of the key parameters and the modified settings in the file. Also assigns the file extension automatically according to the source code format.
6. To preview the content of the SCPI list:
  - a) Select "System Config > Save/Recall".
  - b) Select "Operation Mode > SCPI-Export".
  - c) In the `/var/user/` directory, select a previously saved file.
  - d) Select "Show SCPI List".

The list of all SCPI commands is displayed, for example, for a final check.



Exporting the SCPI list of the instrument state in one step is a fast and convenient method. Nevertheless, it usually requires postprocessing on an external PC.

#### How to check an SCPI list

The easiest way to check a list, is to execute it. The generator returns a warning if a setting could not be performed.

However, we recommend that you check the list and possibly rework. It can be that ...

- A parameter has not assigned an SCPI command or an element of the user interface has not an assigned parameter. In these cases, `:SYST:INF:SCPI 'SCPI command not available'` is entered in the list instead. Such entries are also detected during execution. The instrument recognizes these incomplete commands and displays an error message.
- A preset has been executed, but several standards subsequently perform some internal settings that are also assigned to the list with "SCPI Export".
- After a preset still some settings are defined, which are then written to the list generated with "SCPI Export."

Some suggestions on how you can check and revise a list:

1. Search and remove missing command entries.
2. Remove unnecessary content written after a preset.
3. Rearrange the commands to a reasonable order. If you, for example, set a `STATE` command to the last position of a list, you can avoid intermediate calculations of the signal.
4. Preview the list for completeness by comparing it with the modified settings in the manual mode.
  - a) To retrace your settings in manual operation, open the context-sensitive menu and select "Mark all parameters changed from preset". The function identifies all settings you have changed, both in the block diagram, and in the dialogs. They appear orange.
  - b) Check whether there is a command in the list for all modified settings.
5. To perform modifications, export the list to a PC, using for example a USB flash drive.

### 13.8.5 How to Convert and Save SCPI Lists

After completing the recording, the "SCPI Recording Export" dialog opens.

1. Select the "Format" for the command syntax in which you want to save the list.
2. "Select Code Template"  
Depending on the selected format, proceed accordingly:  
**Note:** Select the code template **before** exporting.
  - a) Plain SCPI  
Continue with the next step.
  - b) Predefined code generator  
The "SCPI Recording Export - Select Predefined Code Template" dialog opens. Select one of the predefined code templates.

- c) User code generator
  - A file system ("SCPI Recording Export - Select User Code Template") dialog opens.
  - Select your user-defined code template. The code template must have file extension \*.expcodetmpl.
3. Select "File..."
  - The "SCPI Recording Export - Select Output File" dialog opens.
4. Select "New" and assign a filename for saving the recorded list.
5. In the "SCPI Recording Export" dialog, select "Export".
  - Saves the recorded data either in ASCII format (plain SCPI), or in the corresponding format of the used code template, and shows the SCPI list in the "File Content" section.

### 13.8.6 How to Find Out the SCPI Commands for GUI Functions

#### Findig out the SCPI command using "Show SCPI Command"

1. To find out the SCPI command of a parameter in manual operation, select the respective parameter.
2. Open the context-sensitive menu and select "Show SCPI command"

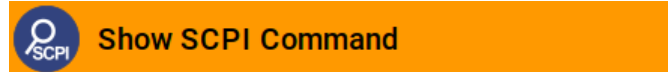

You get the detailed command syntax, including the currently set value.

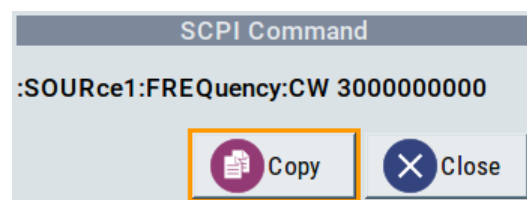

With the "Copy" function, you can conveniently paste the command including the current setting, e.g., in a command script.

#### Findig out the SCPI command using the online help

If you are looking for the remote command to a function in manual operation, you find it in the description of the online help.

1. To find out the SCPI command of a parameter in manual operation, select the respective parameter.
2. To open the corresponding help topic, select one of the following:
  - In the display, select "context-sensitive menu > Help".

 Help

- On the front panel, press the [Help] key.

The help topic opens. Apart from the function description, it contains the SCPI command in detailed syntax.

**How to find the corresponding GUI function to a command**

Conversely, if you are looking for a function in the GUI, which belongs to a SCPI, you find it via a cross-reference in the online help and in the user manual.

## 13.9 Operating the R&S SMA100B Remotely via VNC

This section shows you some examples of the various possibilities to set up remote operation.

- Using a desktop system
  - [Chapter 13.9.2.1, "Using a Web Browser"](#), on page 425
  - [Chapter 13.9.2.2, "Using a VNC Client Software"](#), on page 425
- Using a smart device
  - [Chapter 13.9.3.1, "Using a VNC App"](#), on page 428
  - [Chapter 13.9.3.2, "Using a Web Browser with HTML5"](#), on page 428
  - [Chapter 13.9.3.3, "Special Mode QR Code "](#), on page 429

### 13.9.1 How To Enable the VNC Service

1. **NOTICE!** Enabled VNC service can lead to unauthorized access.  
Change the computer name and password of the instrument.  
See [Chapter 12.4.5, "How to Prevent Unauthorized Access"](#), on page 365.
2. Select "System Config > Setup > Security > Security > LAN Services".
3. Select "VNC > On".
4. Enter the [Security Password](#).
5. Select "Accept".

## 13.9.2 How To Set Up a Remote Operation from a Desktop System

### 13.9.2.1 Using a Web Browser

The R&S SMA100B supports remote operation via VNC with any web browser, like Windows Internet Explorer or Mozilla Firefox for instance, or alternatively, an HTML5 web browser.

To operate the instrument via a web browser remotely:

1. Install the *JRE (Java Runtime Environment)* on the remote computer.  
**Note:** Skip this step if you are working with an HTML5 web browser.
2. Type the instruments' IP address in the address field of the web browser on your PC, e.g. `http://10.113.1.151`

The VNC authentication screen appears.

3. Enter the password and confirm with "OK".  
The default password is *instrument*.

After the connection is established, the current screen of the signal generator is displayed and the instrument can be remotely operated from the remote computer.

### 13.9.2.2 Using a VNC Client Software

A VNC client software is an application which can be used to access and control the instrument from a remote computer through a LAN connection.

The VNC client software for setting up the connection is included in the operating system Linux/Unix per default. For Windows operating systems, a VNC client software must be installed manually.

Various free-of charge programs such as Ultr@VNC or similar VNC client programs are available for download on the Internet.

#### Setting up the VNC connection on a Linux/Unix desktop client

1. Start a web browser on the remote computer. Enter the IP address of the instrument.
2. Enter the following address:  
`vnc://<IP-address of the instrument>`, for example `vnc://10.113.1.151`.

A dialog opens requesting the password for the remote VNC connection.

3. Enter the password and confirm with "OK".  
The default password is *instrument*.

After the connection is established, the current screen of the signal generator is displayed and the instrument can be remotely operated from the remote computer.

### Setting up the VNC connection on a Windows desktop client

1. Install the VNC viewer program component on the remote computer.
  - a) On the Internet, select a VNC client program and download it onto your PC.  
For example the free of charge software Ultr@VNC (`vncviewer.exe` is available, see <http://www.uvnc.com/download/index.html>.
  - b) Execute the VNC client installation.
  - c) Select the VNC viewer program component and follow the installation instructions.
2. Start VNC viewer program component on the PC.

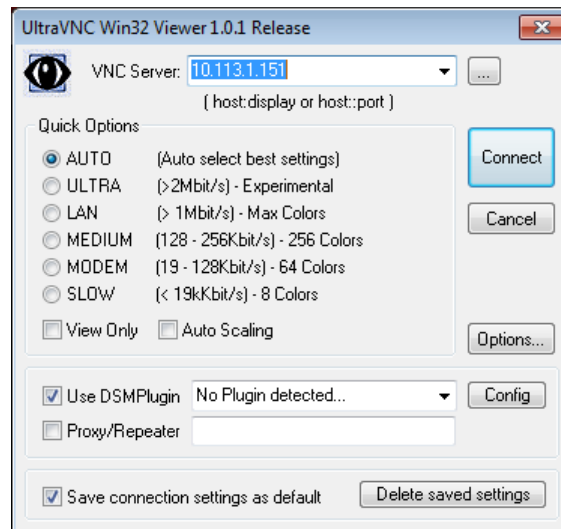

3. Select "VNC Server" and enter the IP address of the instrument.
4. To initialize the connection, select "Connect".  
A dialog opens requesting the password.

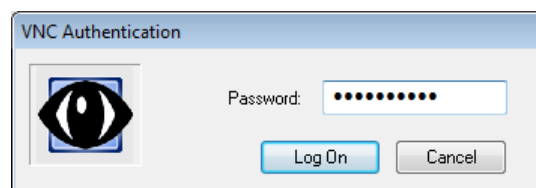

5. Enter the password and confirm with "OK".  
The default password is *instrument*.

After the connection is established, the current screen of the signal generator is displayed and the instrument can be remotely operated from the remote computer.

### Terminating VNC connection

- ▶ Perform one of the following:
  - a) On an external Unix/Linux PC, close the Internet browser or the signal generator window.

b) On an external Windows PC, close the VNC viewer program.

The connection is terminated but not disabled. It can be established again any time.

In the "Active Connections" tab, the displayed TCP/IP connection disappears.

See [Chapter 12.4.5, "How to Prevent Unauthorized Access"](#), on page 365.

### 13.9.3 How To Set Up a Remote Operation from a Smart Device

The R&S SMA100B supports remote operation via VNC from a smart device (remote client), like a tablet (tablet computer) or a smartphone. The smart device accesses the instrument via WLAN, either by a suitable App, or an HTML5 web browser, that means with embedded *javascript*.

There are several possibilities to establish a WLAN connection between the smart device and the R&S SMA100B. This section gives an example of how a network environment can be built up, and some essential configuration steps.

For more information, see:

- [1MA216: Remote Operation of Windows Based Instruments with Apple iPad](#)
- [7BM82: Apple iPad Remote Control of Broadcasting T&M Instruments](#)

**Example:**

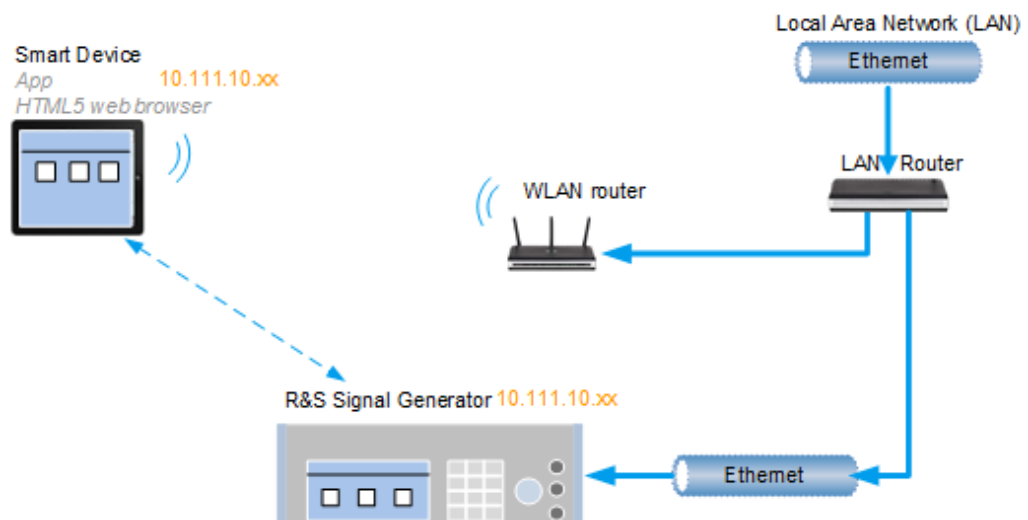

**Figure 13-7: Example of a network configuration for remote operation with a smart device**

As shown in the figure, the R&S SMA100B and the WLAN router are connected to the LAN router. The smart device accesses the Rohde & Schwarz instrument via the WLAN router.

#### Prerequisites

For this network configuration, the following prerequisites must be met:

- The required equipment is:

- A LAN router
- A WLAN router (hot spot)  
Required for accessing the R&S SMA100B
- The smart device must be known and accepted in the network of the R&S SMA100B.
- The *App* or web browser implements the VNC functionality on the smart device for remote operation.

It is recommended that all components in the network use DHCP, which automatically assigns the relevant address information.



With the configuration in the example, you can reach the instrument from a great distance, since the WLAN router acts as an additional access point.

### 13.9.3.1 Using a VNC App

Using a *VNC App* enables the smart device to access the R&S SMA100B via WLAN.

The VNC Apps are available from various manufacturers of the smart devices.

The list of supported devices is different according to the smart device.

1. Refer to the manufacturer's website to find out whether a VNC App is available for your device, and how it is installed.
2. In the network, establish the connection of the WLAN router to the LAN router. We assume the connection of the LAN router and the R&S SMA100B and their configuration in the LAN.
3. Configure the WLAN router according to the manufacturer's instructions.
4. Install the required *VNC App* on your smart device.
5. On the smart device, start the *VNC App*.
6. In the address field, enter the IP address of the instrument.

A log-on dialog opens and requests the password for the VNC connection.

7. Enter the password to establish the remote access.  
The default user name and password is *instrument*.  
See [Chapter 12.4.5, "How to Prevent Unauthorized Access"](#), on page 365.

After the connection is established, the current screen of the signal generator is displayed and the instrument can be remotely operated.

### 13.9.3.2 Using a Web Browser with HTML5

The R&S SMA100B supports remote operation from a smart device via VNC with any HTML5 compliant web browser, like Internet Explorer, Firefox, Google Chrome, or Safari for instance.



To operate the instrument remotely via a web browser, proceed as follows:

1. In the web browser enter the IP address of the instrument, e.g. *http://10.113.1.151*.
2. Type the instrument IP address in the address field of the web browser on your PC, e.g. *http://10.113.1.151*

The VNC authentication screen appears.

3. Enter the password and confirm with "OK".

The default password is *instrument*.

See [Chapter 12.4.5, "How to Prevent Unauthorized Access"](#), on page 365.

After the connection is established, the current screen of the signal generator is displayed and the instrument can be remotely operated.

### 13.9.3.3 Special Mode QR Code

If your smart device is equipped with a camera and a QR code reader, you can scan the instrument's IP address or access the instrument with the Safari web browser.

QR code readers are available from various manufacturers of the smart devices.

The list of supported devices is different according to the smart device.

1. Refer to the manufacturer's website of your smart device to find out whether a reader is available for your device, and how it is installed.
2. Install the required QR code reader software on your device.
3. Start the reader.
4. On the R&S SMA100B, select "System Config > Remote Access".
5. In the "Remote Access" dialog, select the "QR-Code" tab.
6. Scan the QR code of the instrument with your smart device.
7. On the device, decode the scanned QR code and pass it to the web browser.  
A dialog opens requesting the password for the VNC connection.
8. Enter the password and confirm with "OK".  
The default password is *instrument*.

After the connection is established, the current screen of the signal generator is displayed and the instrument can be remotely operated.

## 13.10 References

### 13.10.1 LXI Functionality

LAN Extensions for Instrumentation (LXI) is an instrumentation platform for measuring instruments and test systems that is based on standard Ethernet technology.

LXI is intended to be the LAN-based successor to GPIB, combining the advantages of Ethernet with the simplicity and familiarity of GPIB. Like GPIB, LXI determines and standardizes the way the instrument behaves in a LAN.

The LXI implementation in the R&S SMA100B allows you to change certain LAN settings, to reset the LAN connection, and to identify the instrument.



For information about the LXI standard, refer to the LXI website at <http://www.lxistandard.org>.

See also "News from Rohde & Schwarz, article 2006/II - 190".

The LXI functionality in the R&S SMA100B is characterized by a common LAN implementation, including an ICMP ping responder for diagnostics. The instrument can be configured via a web browser. A LAN Configuration Initialize (LCI) mechanism resets the LAN configuration. The instrument also supports automatic detection in a LAN via the VXI-11 discovery protocol and programming by IVI drivers.

In addition the R&S SMA100B provides the following LXI-related functionality:

- Integrated "LXI Status" dialog for LXI status indication and reset of the LAN configuration, see [Chapter 13.5.1, "LXI Status Settings"](#), on page 392.
- "LXI Browser Interface", as described in [Chapter 13.5.2.1, "LAN Configuration"](#), on page 395.
- "SCPI Remote Trace" utility, see ["SCPI Remote Trace"](#) on page 397.



#### **Firmware update**

To enable the full LXI functionality after a firmware update, shut down and restart the instrument.

### 13.10.2 Code Generator Templates

This section describes the main structure of the code generator templates, and shows the method by means of the NICVI template.

The code generation is controlled by templates with the following blocks:

Command	Function
#EXTENSION_START #EXTENSION_END	Defines the output file extension.
#INIT_CODE_START #INIT_CODE_END	Contains initial entries, such as included files and libraries, buffer size, commands for synchronization, or creating a VISA session.  All entries between start and end are written once at the beginning of the output file.
#COMMAND_CODE_START #COMMAND_CODE_END	Frame for an SCPI command. A command is accessed with %COMMAND.
#NO_COMMAND_CODE_START #NO_COMMAND_CODE_END	Frame for a parameter with no SCPI command available. A parameter is accessed with %PARAMETER.
#EXIT_CODE_START #EXIT_CODE_END	Closes the visa session.  All entries between start and end are written once at the end of the output file.

Templates are created in ASCII format with file extension \*.expcodetempl.

### Example:

Example to the code generator template NICVI.expcodetmpl:

```
#EXTENSION_START
.c
#EXTENSION_END

#INIT_CODE_START
#include <ansi_c.h>
#include <visa.h>
#include <cvirte.h>

#define MAX_BUFFER_SIZE 200
static ViStatus status;
static ViSession defaultRM, handle;

static void write_command(char *command)
{
    char writeBuffer[MAX_BUFFER_SIZE];
    char readBuffer[MAX_BUFFER_SIZE];
    int length;
    int readCount;

    strcpy(writeBuffer, command);
    //append "*OPC?" to sync
    strcat(writeBuffer, "*OPC?");
    length = strlen (writeBuffer);
    writeBuffer[length]='\n';
```

```

        length = length+1;
        viWrite (handle, writeBuffer, length, VI_NULL);
        //read result
        viRead(handle, readBuffer, 100, &readCount);
    }
int main (int argc, char *argv[])
{
    if (InitCVIRTE (0, argv, 0) == 0)
        return -1;    /* out of memory */
        //create a VISA session and return a handle to it
        viOpenDefaultRM (&defaultRM);
        //create a VISA session to the serial port and return a handle to it
        viOpen (defaultRM, (ViRsrc)"TCPIP::localhost::INSTR", VI_NULL, VI_NULL,
&handle);
#INIT_CODE_END

#COMMAND_CODE_START
    write_command("%COMMAND");
#COMMAND_CODE_END

#NO_COMMAND_CODE_START
    //no SCPI command available for parameter %PARAMETER !
#NO_COMMAND_CODE_END

#EXIT_CODE_START
    viClose (handle);
        viClose (defaultRM);
        return 0;
}
#EXIT_CODE_END

```

### 13.10.3 Remote Control States

#### How to recognize if there is an active remote connection to the instrument

- Observe the indication on the taskbar.



**SCPI, VNC,  
SMB, FTP**

A softkey in the taskbar indicates if and what kind of remote connections are currently set up.

See also [Chapter 13.4.6, "Remote Connections Settings"](#), on page 389.

The following table shows the different remote control states and the associated commands or actions to return to manual control.

Table 13-3: Remote control status icons

GUI symbol	Transition to remote control state...	Transition to manual operation...(local state)
 	<p>&amp;GTR (controller)</p> <p>Remote control, but usable front panel keys. The parameters are in read-only mode.</p>	<ul style="list-style-type: none"> <li>• &amp;GTL (controller)</li> <li>• Tap the "Remote" icon (display)</li> <li>• [Local] (front panel or key emulation)</li> </ul> <p>A currently performed setting is indicated by the green arrows.</p> <p>The setting must be completed (white arrows), otherwise the instrument remains in remote state.</p>
	<p>&amp;LLO (controller)</p> <p>Remote control with locked front panel keys to prevent user interaction. The parameters are in read-only mode.</p> <p>You can unlock LLO, and thus return to manual operation only via remote control.</p>	<ul style="list-style-type: none"> <li>• &amp;LOCS (controller)</li> <li>• CALL IBLOC (generator%) (controller)</li> </ul> <p><b>Note:</b> The command &amp;REMS returns to "Remote" state.</p>

# 14 Remote Control Commands

In the following, all remote-control commands are presented in detail with their parameters and the ranges of numerical values.

For an introduction to remote control and the status registers, refer to:

- [Chapter 13, "Network Operation and Remote Control"](#), on page 371
- [Chapter A.1, "Additional Basics on Remote Control"](#), on page 751

## 14.1 Conventions Used in SCPI Command Descriptions

Note the following conventions used in the remote command descriptions:

- **Command usage**  
If not specified otherwise, commands can be used both for setting and for querying parameters.  
If a command can be used for setting or querying only, or if it initiates an event, the usage is stated explicitly.
- **Parameter usage**  
If not specified otherwise, a parameter can be used to set a value and it is the result of a query.  
Parameters required only for setting are indicated as **Setting parameters**.  
Parameters required only to refine a query are indicated as **Query parameters**.  
Parameters that are only returned as the result of a query are indicated as **Return values**.
- **Conformity**  
Commands that are taken from the SCPI standard are indicated as **SCPI confirmed**. All commands used by the R&S SMA100B follow the SCPI syntax rules.
- **Asynchronous commands**  
A command which does not automatically finish executing before the next command starts executing (overlapping command) is indicated as an **Asynchronous command**.
- **Reset values (\*RST)**  
Default parameter values that are used directly after resetting the instrument (\*RST command) are indicated as **\*RST values**, if available.
- **Factory preset values**  
Default parameter values that are reset only by factory preset.
- **Default unit**  
The default unit is used for numeric values if no other unit is provided with the parameter.
- **Manual operation**  
If the result of a remote command can also be achieved in manual operation, a link to the description is inserted.

## 14.2 Programming Examples

The corresponding sections of the same title provide simple programming examples for the R&S SMA100B. The purpose of the examples is to present **all** commands for a given task. In real applications, one would rather reduce the examples to an appropriate subset of commands.

The programming examples have been tested with a software tool which provides an environment for the development and execution of remote tests. To keep the examples as simple as possible, only the "clean" SCPI syntax elements are reported. Non-executable command lines (for example comments) start with two // characters.

At the beginning of the most remote control program, an instrument (p)reset is recommended to set the R&S SMA100B to a definite state. The commands `*RST` and `SYSTem:PRESet` are equivalent for this purpose. `*CLS` also resets the status registers and clears the output buffer.

In all the examples we assume that:

- A remote PC is connected to the instrument
- The remote PC and the instrument are switched on
- A connection between them is established
- The security setting "System Config > Setup > Security > SCPI over LAN" is enabled.

## 14.3 Common Commands

Common commands are described in the IEEE 488.2 (IEC 625-2) standard. These commands have the same effect and are employed in the same way on different devices. The headers of these commands consist of "\*" followed by three letters. Many common commands are related to the Status Reporting System.

Available common commands:

<code>*CLS</code> .....	436
<code>*ESE</code> .....	436
<code>*ESR?</code> .....	436
<code>*IDN?</code> .....	436
<code>*IST?</code> .....	437
<code>*OPC</code> .....	437
<code>*OPT?</code> .....	437
<code>*PRE</code> .....	437
<code>*PSC</code> .....	437
<code>*RCL</code> .....	438
<code>*RST</code> .....	438
<code>*SAV</code> .....	438
<code>*SRE</code> .....	439
<code>*STB?</code> .....	439

*TRG.....	439
*TST?.....	439
*WAI.....	439

---

### \*CLS

Clear status

Sets the status byte (STB), the standard event register (ESR) and the `EVENT` part of the `QUESTIONABLE` and the `OPERATION` registers to zero. The command does not alter the mask and transition parts of the registers. It clears the output buffer.

**Usage:**                    Setting only

---

### \*ESE <Value>

Event status enable

Sets the event status enable register to the specified value. The query returns the contents of the event status enable register in decimal form.

**Parameters:**

<Value>                    Range:     0 to 255

---

### \*ESR?

Event status read

Returns the contents of the event status register in decimal form and then sets the register to zero.

**Return values:**

<Contents>                Range:     0 to 255

**Usage:**                    Query only

---

### \*IDN?

Identification

Returns the instrument identification.

**Return values:**

<ID>                        "Rohde&Schwarz,<device type>,<part number>/<serial number>,<firmware version>"

**Example:**                Rohde&Schwarz,SMA100B,1419.8888K02/0,4.00.033

**Usage:**                    Query only

**Manual operation:**    See "[IDN String](#)" on page 389



---

**\*IST?**

Individual status query

Returns the contents of the IST flag in decimal form. The IST flag is the status bit which is sent during a parallel poll.

**Return values:**

<ISTflag>            0 | 1

**Usage:**                Query only

---

**\*OPC**

Operation complete

Sets bit 0 in the event status register when all preceding commands have been executed. This bit can be used to initiate a service request. The query writes a "1" into the output buffer when all preceding commands have been executed, which is useful for command synchronization.

---

**\*OPT?**

Option identification query

Queries the options included in the instrument. For a list of all available options and their description, refer to the data sheet.

**Return values:**

<Options>            The query returns a list of options. The options are returned at fixed positions in a comma-separated string. A zero is returned for options that are not installed.

**Usage:**                Query only

**Manual operation:**   See "[OPT String](#)" on page 389

---

**\*PRE <Value>**

Parallel poll register enable

Sets parallel poll enable register to the indicated value. The query returns the contents of the parallel poll enable register in decimal form.

**Parameters:**

<Value>                Range:     0 to 255

---

**\*PSC <Action>**

Power on status clear

Determines whether the contents of the `ENABLE` registers are preserved or reset when the instrument is switched on. Thus a service request can be triggered when the instrument is switched on, if the status registers ESE and SRE are suitably configured. The query reads out the contents of the "power-on-status-clear" flag.

**Parameters:**

<Action> 0 | 1

**0**

The contents of the status registers are preserved.

**1**

Resets the status registers.

**\*RCL** <Number>

Recall

Loads the instrument settings from an intermediate memory identified by the specified number. The instrument settings can be stored to this memory using the command `*SAV` with the associated number.

It also activates the instrument settings which are stored in a file and loaded using the `MMEMory:LOAD <number>, <file_name.extension>` command.

**Manual operation:** See "[Recall Immediate x](#)" on page 314

**\*RST**

Reset

Sets the instrument to a defined default status. The default settings are indicated in the description of commands.

The command is equivalent to `SYSTem:PRESet`.

**Usage:** Setting only

**Manual operation:** See "[Preset](#)" on page 307

**\*SAV** <Number>

Save

Stores the current instrument settings under the specified number in an intermediate memory. The settings can be recalled using the command `*RCL` with the associated number.

To transfer the stored instrument settings in a file, use the command `:MMEMory:STORe:STATe`.

**Manual operation:** See "[Save Immediate x](#)" on page 313

---

**\*SRE** <Contents>

Service request enable

Sets the service request enable register to the indicated value. This command determines under which conditions a service request is triggered.

**Parameters:**

<Contents>                      Contents of the service request enable register in decimal form.  
    Bit 6 (MSS mask bit) is always 0.  
    Range:        0 to 255

---

**\*STB?**

Status byte query

Reads the contents of the status byte in decimal form.

**Usage:**                      Query only

---

**\*TRG**

Trigger

Triggers all actions waiting for a trigger event. In particular, \*TRG generates a manual trigger signal. This common command complements the commands of the TRIGger subsystem.

**Usage:**                      Event

---

**\*TST?**

Self-test query

Initiates self-tests of the instrument and returns an error code.

**Return values:**

<ErrorCode>                      **integer > 0 (in decimal format)**  
    An error occurred.  
    (For details, see the Service Manual supplied with the instrument).  
    **0**  
    No errors occurred.

**Usage:**                      Query only

---

**\*WAI**

Wait to continue

Prevents servicing of the subsequent commands until all preceding commands have been executed and all signals have settled (see also command synchronization and \*OPC).

**Usage:** Event

## 14.4 Preset Commands

The preset commands are not bundled in one subsystem. Therefore, they are listed separately in this section.

Four presetting actions are available:

- Activating the default state of all internal instrument functions (\*RST on page 438). Functions that concern the integration of the instrument into a measurement setup are not changed, e.g. reference oscillator source settings.
- Activating the preset state of the parameters related to the selected signal path (:SOURce<hw>:PRESet on page 440)
- Activating the preset state of all parameters that are not related to the signal path (:DEVIce:PRESet on page 440)
- Activating the original state of delivery (factory reset, :SYSTem:FPRreset on page 441). Only functions that are protected by a password remain unchanged as well as the passwords themselves.



When resetting, the following deviation between remote and manual control exists:

In contrast to the [Preset] key, the SCPI commands \*RST and :SYSTem:PRESet do not close open dialogs in the GUI.

:DEVIce:PRESet.....	440
:SOURce<hw>:PRESet.....	440
:SYSTem:PRESet.....	441
:SYSTem:FPRreset.....	441

---

### :DEVIce:PRESet

Presets all parameters which are not related to the signal path, including the LF generator.

**Example:** DEV:PRES  
Presets all instruments settings that are not related to the signal path.

**Usage:** Event

---

### :SOURce<hw>:PRESet

Presets all parameters which are related to the selected signal path.

**Example:** `SOUR:PRES`  
Presets all settings that are related to signal path

**Usage:** Event

#### **:SYSTem:PRESet**

Triggers an instrument reset. It has the same effect as:

- The [Preset] key.  
However, the command does not close open GUI dialogs like the key does.
- The `*RST` command

For an overview of the settings affected by the preset function, see [Table 11-1](#)

**Example:** `SYST:PRES`  
All instrument settings (also the settings that are not currently active) are reset to their default values.

**Usage:** Setting only

**Manual operation:** See "[Preset](#)" on page 307

#### **:SYSTem:FPReset**

Triggers an instrument reset to the original state of delivery.

**Example:** `SYST:FPR`  
All instrument settings (also the settings that are not currently active) are reset to the factory values.

**Usage:** Event

**Manual operation:** See "[Execute Factory Preset](#)" on page 308

## 14.5 MMEMory Subsystem

The `MMEMory` subsystem (Mass MEMory) contains the commands for managing files and directories as well as for loading and storing complete instrument settings in files.

### **Mass storage location**

Without any additional measures, the R&S SMA100B stores user files on the internal memory, the removable memory, or if connected, on a memory stick.

Both, the user directory `/var/user/` on the internal memory or the `/usb/` directory on the memory stick, can be used to **preserve** user-defined data. Any directory structure can be created.

The `/var/volatile` directory serves as a RAM drive and can be used to protect sensitive information. The data is available **temporarily**.

If option R&S SMAB-B85 is installed, the R&S SMA100B maps the user directory to the removable memory. If a memory is mounted, user data is saved there. Otherwise user data is redirected to the volatile memory.

### Default storage location

The R&S SMA100B stores user data in the user directory.

Depending on the installed options, the user directory is physically located on the internal memory or on the removable memory.

In the file system, user directory is always indicated as `/var/user/`.

In manual control, you access this directory via the "File Manager", see [Chapter 11.8, "Using the File Manager"](#), on page 318. In remote control, you can query it with the command `:SYSTem:MMEMory:PATH:USER?`.

To query and change the default directory used for mass storage, use the command `:MMEMory:CDIRectory`.

## 14.5.1 File Naming Conventions

To enable files to be used in different file systems, consider the following file naming conventions:

- The *filename* can be of any length and *is case-sensitive*, i.e. it is distinguished between uppercase and lowercase letters.
- All letters and numbers are permitted (numbers are, however, not permitted at the beginning of the filename).
- Avoid using special characters.
- Do not use slashes "\" and "/". These symbols are used in file paths.
- Avoid using the following filenames: CLOCK\$, CON, COM1 to COM4, LPT1 to LPT3, NUL or PRN  
They are reserved by the operating system.

### File extension

The file and the optional file *extension* are separated by a period sign. The R&S SMA100B distinguishes the files according to their extensions; each type of file is assigned a specific file content and hence a specific file extension. Refer to [Chapter A.3, "Extensions for User Files"](#), on page 777 for an overview of the supported file extensions.

### Wildcards

The two characters "\*" and "?" function as "wildcards", i.e. they are used for selecting several files. The "?" character represents exactly one character, while the "\*" character represents all characters up to the end of the filename. "\*.\*" therefore represents all files in a directory.

### Filename and file path

When used in remote control commands, the parameter `<filename>` is specified as a string parameter with quotation marks. It can contain either the complete path including the root user directory `/var/user` and filename, or only the filename. The filename must include the file extension. The same applies for the directory `/var/volatile` and for the parameters `<directory_name>` and `<path>`.

Depending on how much information is provided, the values specified in the parameter or with the command `MMEM:CDIR` are used for the path and drive setting in the commands.

## 14.5.2 Accessing Files in the Default or in a Specified Directory

For better overview and easy file handling, you may not save all user files in the user directory `/var/user` but rather organize them into subdirectories.

The command syntax defines two general ways to access files with user data in a *specific* directory:

- **Change the current default directory** for mass memory storage and then directly access the files in this default directory, like stored list files, files with user data or save/recall files.  
The subsequent commands for file handling (select, delete, read out files in the directory, etc.) require only specification of the filename. File extension can be omitted; after syntax evaluation of the used command, the R&S SMA100B filters out the relevant files.
- Define the **absolute file path**, including the user directory `/var/user`, created subdirectories and filename (see [Example "Load file with user data from a specific directory"](#) on page 443).  
As a rule, whenever an absolute file path is determined, it overwrites a previously specified default directory.

The following example explains this rule as a principle. Exceptions of this general rule are stated in the description of the corresponding command. The [Chapter 14.5.3, "Programming Examples"](#), on page 444 explains the general working principle with the commands for mass memory storage.

The same rule applies to the `/var/volatile` directory, see [Example "Working with files in the volatile memory"](#) on page 445.

### Example: Load file with user data from a specific directory

This example shows the principle of file handling in remote environment by using list commands. Working with the files of other subsystems is analogical. We assume that the directory `/var/user/my_files` is existing and contains the files `list_test.lsw` and `list_2.lsw`.

```
//Query files in the user directory
SOURCE1:LIST:CATalog?
// -
```

```
// no files

// Set the default directory
MMEMory:CDIRECTory "/var/user/my_files"
SOURCEl:LIST:CATalog?
// "list_test","list_2"

// Specify the complete path to select a list file (*.lsw)
// in the specific directory
SOURCEl:LIST:SElect "/var/user/my_files/list_test"
SOURCEl:LIST:DElete "/var/user/my_files/list_2"
```

### 14.5.3 Programming Examples

#### Example: Storing and loading current settings

This example shows two ways of how to store the current instrument setting in the file `settings.savrcl.txt` in the directory `/var/user/savrcl`.



Before the instrument settings can be stored in a file, they have to be stored in an intermediate memory using common command `*SAV <number>`. The specified number is then used in the `:MMEMory:STORe:STATe` command.

Also, after loading a file with instrument settings with command `:MMEMory:LOAD:STATe`, these settings have to be activated with the common command `*RCL <number>`.

```
// Store the current settings in an intermediate memory with number 4
*SAV 4

// store the settings in a file in a specific directory;
// the complete path has to be specified
MMEMory:STORe:STATe 4,"/var/user/savrcl/settings.savrcl.txt"

// store the settings in a file in the default directory;
// set the default directory; specify only the file name
MMEMory:CDIRECTory "/var/user/savrcl"
*SAV 4
MMEMory:STORe:STATe 4,"settings.savrcl.txt"

// Load the stored settings in the intermediate memory 4 and activate them
MMEMory:LOAD:STATe 4,"/var/user/settings.savrcl.txt"
*RCL 4
```

#### Example: Working with files and directories

This example shows how to list files in a directory, list the subdirectories, query the number of files in a directory, create directory, rename and delete files.



```

// Query the current default directory for mass storage,
// change the directory to the default user directory "/var/user"
// and read out the files in it
MMEemory:CDIRectory?
// "/var/user/temp"
MMEemory:CDIRectory
MMEemory:CDIRectory?
// "/var/user/"
MMEemory:CATalog?
// 1282630,8102817792,".,DIR,4096","..,DIR,4096","Log,DIR,4096",
// "settings.savrcrltxt,BIN,16949","temp,DIR,4096","test,DIR,4096",
// "list.lsw,BIN,1245201"
// the directory "/var/user" contains the predefined directory "Log",
// the subdirectories "test" and "temp"
// as well as the files "settings.savrcrltxt" and "list.lsw"

// query only the subdirectories of the current or specified directory
MMEemory:DCATalog? "/var/user"
// ".,","..","Log","temp","test"

// query only number of subdirectories in the current or specified directory
MMEemory:DCATalog:LENGth? "/var/user"
// 5

// query number of files in the current or specified directory
MMEemory:CATalog:LENGth? "/var/user"
// 7

// Create a new directory for mass memory storage in the specified directory
MMEemory:MDIRectory "/var/user/new"

// Copy the file "settings.savrcrltxt" into the new directory
MMEemory:COPY "/var/user/settings.savrcrltxt","/var/user/new/settings.savrcrltxt"

// Rename the file "settings.savrcrltxt" into the new directory
// and read out the files in this specific directory
MMEemory:CDIRectory "/var/user/new"
MMEemory:MOVE "settings.savrcrltxt","settings_new.savrcrltxt"
MMEemory:CATalog? "/var/user/new"
// 25141,8102789120,".,DIR,4096","..,DIR,4096","settings_new.savrcrltxt,BIN,16949"

// Delete the "test" directory
MMEemory:RDIRectory "/var/user/test"

```

### Example: Working with files in the volatile memory

This example shows how to work with files in the `/var/volatile` directory.

```

// Change the default directory for mass storage,
// read out the files, load and play a file with the ARB

```

```

MMEMory:CDIRectory "/var/volatile"
MMEMory:CDIRectory?
// "/var/volatile"
MMEMory:CATalog?
//13928,525352960,".,DIR,60",".,DIR,4096","list.lst,BIN,9772"

:SOURce1:LIST:SElect "/var/volatile/list"
:SOURce1:FREQuency:MODE LIST
:OUTPut1:STATe 1

```

#### 14.5.4 Remote Control Commands

:MMEMory:CATalog?	446
:MMEMory:CATalog:LENGth?	447
:MMEMory:CDIRectory	447
:MMEMory:COpy	447
:MMEMory:DATA	448
:MMEMory:DCATalog?	449
:MMEMory:DCATalog:LENGth?	449
:MMEMory:DELeTe	449
:MMEMory:LOAD:STATe	449
:MMEMory:MDIRectory	450
:MMEMory:MOVE	450
:MMEMory:MSIS	450
:MMEMory:RDIRectory	451
:MMEMory:STORE:STATe	451
:MEMory:HFRee?	451

---

#### :MMEMory:CATalog? <path>

Returns the content of a particular directory.

##### Query parameters:

<path>	string
--------	--------

String parameter to specify the directory.  
If you leave out the path, the command returns the contents of the directory selected with `:MMEMory:CDIRectory`.  
The path may be relative or absolute.

##### Return values:

<UsedDiskSpace>	Byte size of all files in the directory.
<FreeDiskSpace>	Remaining disk space in bytes.
<FileInfo>	<NameFileN>,<SuffixFileN>,<SizeFileN>

List of files, separated by commas

**<NameFileN>**  
Name of the file.

**<SuffixFileN>**  
Type of the file. Possible suffixes are: ASCii, BINary, DIRectory

**<SizeFileN>**

Size of the file in bytes.

**Usage:** Query only

**Manual operation:** See "[Directory, File List and Filename](#)" on page 312

**:MMEMory:CATalog:LENGth? <Path>**

Returns the number of files in the current or in the specified directory.

**Query parameters:**

**<Path>** string  
String parameter to specify the directory. If the directory is omitted, the command queries the content of the current directory, queried with `:MMEMory:CDIRectory` command.

**Return values:**

**<FileCount>** integer  
Number of files.

**Usage:** Query only

**:MMEMory:CDIRectory <Directory>**

Changes the default directory for mass memory storage. The directory is used for all subsequent `MMEM` commands if no path is specified with them.

**Parameters:**

**<Directory>** <directory\_name>  
String containing the path to another directory. The path can be relative or absolute.  
To change to a higher directory, use two dots '..'.

**Usage:** SCPI confirmed

**Manual operation:** See "[Directory, File List and Filename](#)" on page 312

**:MMEMory:COpy <SourceFile>[,<DestinationFile>]**

Copies an existing file to a new file. Instead of just a file, this command can also be used to copy a complete directory together with all its files.

**Setting parameters:**

**<SourceFile>** string  
String containing the path and file name of the source file

**<DestinationFile>** string  
 String containing the path and name of the target file. The path can be relative or absolute.  
 If **<DestinationFile>** is not specified, the **<SourceFile>** is copied to the current directory, queried with the **:MMEMory:CDIRectory** command.  
**Note:** Existing files with the same name in the destination directory are overwritten without an error message.

**Usage:** Setting only  
 SCPI confirmed

**Manual operation:** See "[Cut, Copy&Paste and Delete](#)" on page 320

**:MMEMory:DATA** <Filename>, <BinaryBlock>  
**:MMEMory:DATA?** <Filename>

The setting command writes the block data **<BinaryBlock>** to the file identified by **<Filename>**.

**Tip:** Use this command to read/transfer stored instrument settings or waveforms directly from/to the instrument.

**Parameters:**

**<BinaryBlock>** #<number><length\_entry><data>  
 #: Hash sign; always comes first in the binary block  
 <number>: the first digit indicates how many digits the subsequent length entry has  
 <length\_entry>: indicates the number of subsequent bytes  
 <data>: binary block data for the specified length.  
 For files with a size with more than nine digits (gigabytes), the instrument allows the syntax # (<Length>), where <Length> is the file size in decimal format.

**Parameters for setting and query:**

**<Filename>** string  
 String parameter to specify the name of the file.

**Example:** `MMEMory:DATA '/var/user/test.txt',#15hallo`  
 Writes the block data to the file `test.txt`.  
 The digit 1 indicates a length entry of one digit; the digit 5 indicate a length of the binary data (`hallo`) in bytes.  
`MMEMory:DATA? '/var/user/test.txt'`  
 Sends the data of the file `test.txt` from the instrument to the controller in the form of a binary block.  
 Response: `#15hallo`

**Usage:** SCPI confirmed

---

**:MMEMory:DCATalog?** <path>

Returns the subdirectories of a particular directory.

**Query parameters:**

<path> String parameter to specify the directory. If the directory is omitted, the command queries the content of the current directory, queried with `:MMEMory:CDIRectory` command.

**Return values:**

<Catalog> <file\_entry>  
Names of the subdirectories separated by colons. The first two strings are related to the parent directory.

**Usage:** Query only

---

**:MMEMory:DCATalog:LENGth?** [<Path>]

Returns the number of subdirectories in the current or specified directory.

**Query parameters:**

<Path> String parameter to specify the directory. If the directory is omitted, the command queries the contents of the current directory, to be queried with `:MMEMory:CDIRectory` command.

**Return values:**

<DirectoryCount> integer  
Number of parent and subdirectories.

**Usage:** Query only

---

**:MMEMory:DELeTe** <Filename>

Removes a file from the specified directory.

**Setting parameters:**

<Filename> string  
String parameter to specify the name and directory of the file to be removed.

**Usage:** Event  
SCPI confirmed

**Manual operation:** See "[Cut, Copy&Paste and Delete](#)" on page 320

---

**:MMEMory:LOAD:STATe** <SavRclStateNumb>, <file\_name>

Loads the specified file stored under the specified name in an internal memory.

After the file has been loaded, the instrument setting must be activated using an `*RCL` command.

**Setting parameters:**

<SavRclStateNumb> Determines to the specific <number> to be used with the \*RCL command, e.g. \*RCL 4.

<file\_name> String parameter to specify the file name with extension \*.savrc1txt.

**Usage:** Setting only

**Manual operation:** See "[Recall](#)" on page 314

**:MMEMory:MDIRECTory <Directory>**

Creates a subdirectory for mass memory storage in the specified directory. If no directory is specified, a subdirectory is created in the default directory. This command can also be used to create a directory tree.

**Setting parameters:**

<Directory> string  
String parameter to specify the new directory.

**Usage:** Event

**Manual operation:** See "[Create New Directory](#)" on page 320

**:MMEMory:MOVE <SourceFile>, <DestinationFile>**

Moves an existing file to a new location or, if no path is specified, renames an existing file.

**Setting parameters:**

<SourceFile> string  
String parameter to specify the name of the file to be moved.

<DestinationFile> string  
String parameters to specify the name of the new file.

**Usage:** Event  
SCPI confirmed

**Manual operation:** See "[Rename](#) " on page 320

**:MMEMory:MSIS <Msis>**

Defines the drive or network resource (in the case of networks) for instruments with windows operating system, using `msis` (MSIS = Mass Storage Identification String).

**Note:** Instruments with Linux operating system ignore this command, since Linux does not use drive letter assignment.

**Usage:** SCPI confirmed

---

**:MMEMory:RDIRectory** <Directory>

Removes an existing directory from the mass memory storage system. If no directory is specified, the subdirectory with the specified name is deleted in the default directory.

**Setting parameters:**

<Directory>                    string  
                                      String parameter to specify the directory to be deleted.

**Usage:**                        Event

---

**:MMEMory:STORE:STATe** <savrcl\_state\_nr>, <file\_name>

Stores the current instrument setting in the specified file.

The instrument setting must first be stored in an internal memory with the same number using the common command \*SAV.

**Setting parameters:**

<savrcl\_state\_nr>                Corresponds to the specific <number> defined with the \*SAV command, e.g. \*SAV 4.

<file\_name>                        String parameter to specify the file name with extension \*.savrcltxt.

**Usage:**                        Event

**Manual operation:**        See "[Save](#)" on page 313

---

**:MEMory:HFRee?**

Returns the used and available memory in Kb.

**Return values:**

<TotalPhysMemKb>                integer  
                                      Total physical memory.

<ApplicMemKb>                    integer  
                                      Application memory.

<HeapUsedKb>                     integer  
                                      Used heap memory.

<HeapAvailableKb>                integer  
                                      Available heap memory.

**Usage:**                        Query only

## 14.6 CALibration Subsystem

The CALibration subsystem contains the commands needed for performing internal adjustments. This procedure is triggered by the query commands.

### Suffix <hw>

Suffix	Value range	Description
CALibration<hw>	[1]	Optional suffix

### Understanding the query response

- 0: error-free execution of the adjustments
- 1: indicates that an error occurred; the process has been canceled

:CALibration:ALL[:MEASure]?	452
:CALibration<hw>:ALL:DATE?	452
:CALibration<hw>:ALL:INformation?	453
:CALibration<hw>:ALL:TEMP?	453
:CALibration<hw>:ALL:TIME?	453
:CALibration:DATA:FACTory:DATE?	454
:CALibration<hw>:CONTinueonerror	454

---

### :CALibration:ALL[:MEASure]? [<Force>]

Starts all internal adjustments that do not need external measuring equipment.

**NOTICE!** High power at the RF output applied during internal adjustment can destroy a connected DUT (device under test).

How to: See "[Running internal adjustments](#)" on page 746.

#### Query parameters:

<Force> string

#### Return values:

<Measure> 0 | 1 | OFF | ON

#### Example:

```
CAL:ALL:MEAS?
// 0
// Executes the adjustments of all instrument functions.
// When completed, it indicates that the adjustment
// has been performed successfully.
```

**Usage:** Query only

**Manual operation:** See "[Adjust All](#)" on page 745

---

### :CALibration<hw>:ALL:DATE?

Queries the date of the most recently executed full adjustment.



**Suffix:**  
 <hw> [1]  
 Optional suffix

**Return values:**  
 <Date> string

**Example:** CAL:ALL:DATE?  
 // "2016-01-01"

**Usage:** Query only

**Manual operation:** See "[Last Full Adjustment](#)" on page 745

**:CALibration<hw>:ALL:INFormation?**

Queries the current state of the internal adjustment.

**Return values:**  
 <CallInfoText> string

**Example:** CAL:ALL:INF?  
 "Instrument is calibrated, no adjustment required."  
 "UNCAL, instrument is warming up."  
 "UNCAL, Please perform full adjustment after warming up."  
 "UNCAL, Please perform full adjustment."

**Usage:** Query only

**Manual operation:** See "[Information](#)" on page 746

**:CALibration<hw>:ALL:TEMP?**

Queries the temperature deviation compared to the calibration temperature.

**Suffix:**  
 <hw> [1]  
 Optional suffix

**Return values:**  
 <Temperature> string

**Example:** CALibration:ALL:TEMP?  
 // "+12.00 K"

**Usage:** Query only

**Manual operation:** See "[Temperature Offset](#)" on page 746

**:CALibration<hw>:ALL:TIME?**

Queries the time elapsed since the last full adjustment.

**Return values:**  
 <Time> string

**Example:**            `CAL:ALL:TIME?`  
                           `// "22 days"`

**Usage:**             Query only

**Manual operation:** See ["Time"](#) on page 745

#### **:CALibration:DATA:FACTory:DATE?**

Queries the date of the last factory calibration.

**Return values:**

<Date>                string

**Example:**            `CAL:DATA:FACT:DATE?`  
                           `// "2016-01-01"`

**Usage:**             Query only

**Manual operation:** See ["Last Factory Calibration"](#) on page 732

#### **:CALibration<hw>:CONTinueonerror <State>**

Continues the calibration even though an error was detected. By default adjustments are aborted on error.

**Suffix:**

<hw>                    [1]  
                           Optional suffix

**Parameters:**

<State>                0 | 1 | OFF | ON  
                           \*RST:            n.a. (factory preset: 0)

**Example:**            `CAL:CONT ON`  
                           `// Continues calibration after an error`

**Manual operation:** See ["Continue Adjustment on Error"](#) on page 746

## 14.7 CSYNthesis Subsystem

This subsystem contains the commands used to define the frequency settings for the separate clock source (clock synthesis).

Option: see ["Required options"](#) on page 298.

**Example:**

```

CSYNthesis:OTYPe DSIN
CSYNthesis:FREQuency 10000000
CSYNthesis:POWer -15
CSYNthesis:OFFSet:STATe 1
CSYNthesis:OFFSet 0.1
CSYNthesis:PHASe 180
CSYNthesis:PHASe:REFerence
CSYNthesis:PHASe?
// 0
CSYNthesis:FREQuency:STEP:MODE DEC
CSYNthesis:POWer:STEP:MODE DEC
// CSYNthesis:FREQuency:STEP:MODE USER
// CSYNthesis:FREQuency:STEP 1000
// CSYNthesis:FREQuency UP
// 10001000
// CSYNthesis:POWer:STEP:MODE USER
// CSYNthesis:POWer:STEP:INCRement 0.5
CSYNthesis:STATe 1

```

:CSYNthesis:STATe.....	455
:CSYNthesis:OTYPe.....	456
:CSYNthesis:FREQuency.....	456
:CSYNthesis:POWer.....	456
:CSYNthesis:OFFSet:STATe.....	457
:CSYNthesis:OFFSet.....	457
:CSYNthesis:VOLTag.....	457
:CSYNthesis:PHASe.....	457
:CSYNthesis:PHASe:REFerence.....	458
:CSYNthesis:POWer:STEP:MODE.....	458
:CSYNthesis:FREQuency:STEP:MODE.....	458
:CSYNthesis:POWer:STEP[:INCRement].....	458
:CSYNthesis:FREQuency:STEP.....	459

**:CSYNthesis:STATe <State>**

Activates the clock synthesis.

**Parameters:**

<State>            0 | 1 | OFF | ON  
                      \*RST:        0

**Example:**            See [Chapter 14.7, "CSYNthesis Subsystem"](#), on page 454.

**Manual operation:**    See "[State](#)" on page 299

---

**:CSYNthesis:OTYPe** <Mode>

Defines the shape of the generated clock signal.

**Parameters:**

<Mode>                    SESine | DSquare | CMOS | DSINe  
 SESine = single-ended sine  
 DSINe = differential sine  
 DSquare = differential square  
 CMOS = CMOS  
 \*RST:                    SESine

**Example:**                See [Chapter 14.7, "CSYNthesis Subsystem"](#), on page 454.

**Manual operation:**    See "[Output Type](#)" on page 299

---

**:CSYNthesis:FREQuency** <Frequency>

Sets the frequency of the generated clock signal.

**Parameters:**

<Frequency>              float  
**Numerical value**  
 Sets the frequency  
**UP|DOWN**  
 Varies the frequency step by step.  
 The frequency is increased or decreased by the value set with  
 the command `:CSYNthesis:FREQuency:STEP`.  
 Range:            100E3 to 1.5E9  
 Increment:      0.001  
 \*RST:            10E6

**Example:**                See [Chapter 14.7, "CSYNthesis Subsystem"](#), on page 454.

**Manual operation:**    See "[Frequency](#)" on page 300

---

**:CSYNthesis:POWer** <Power>

Sets the power level of the generated clock signal.

**Parameters:**

<Power>                    float  
**Numerical value**  
 Sets the level  
**UP|DOWN**  
 Varies the level step by step.  
 The level is increased or decreased by the value set with the  
 command `:CSYNthesis:POWer:STEP[:INCRement]`.  
 Range:            -24 to 10  
 Increment:      0.01

\*RST: -20

**Example:** See [Chapter 14.7, "CSYNthesis Subsystem"](#), on page 454.

**Manual operation:** See "[Level](#)" on page 300

**:CSYNthesis:OFFSet:STATe** <State>

Activates a DC offset.

**Parameters:**

<State> 0 | 1 | OFF | ON

\*RST: 0

**Example:** See [Chapter 14.7, "CSYNthesis Subsystem"](#), on page 454.

**Manual operation:** See "[DC Offset State](#)" on page 300

**:CSYNthesis:OFFSet** <Offset>

Sets the value of the DC offset.

**Parameters:**

<Offset> float

Range: -5 to 5

Increment: 0.001

\*RST: 0

**Example:** See [Chapter 14.7, "CSYNthesis Subsystem"](#), on page 454.

**Manual operation:** See "[DC Offset](#)" on page 301

**:CSYNthesis:VOLTage** <Voltage>

Sets the voltage for the CMOS signal.

**Parameters:**

<Voltage> float

Range: 0.8 to 2.7

Increment: 0.001

\*RST: 1.8

**Example:**

```
CSYNthesis:OTYPe CMOS
CSYNthesis:VOLTage 1.8
CSYNthesis:FREQuency 100000000
CSYNthesis:STATe 1
```

**Manual operation:** See "[Voltage](#)" on page 301

**:CSYNthesis:PHASe** <Phase>

Shifts the phase of the generated clock signal.

**Parameters:**

<Phase> float  
 Range: -36000 to 36000  
 Increment: 0.1  
 \*RST: 0

**Example:** See [Chapter 14.7, "CSYNthesis Subsystem"](#), on page 454.

**Manual operation:** See ["Delta Phase"](#) on page 301

**:CSYNthesis:PHASe:REFerence**

Resets the delta phase value.

**Example:** See [Chapter 14.7, "CSYNthesis Subsystem"](#), on page 454.

**Usage:** Event

**:CSYNthesis:POWer:STEP:MODE <Mode>****:CSYNthesis:FREQuency:STEP:MODE <Mode>**

Defines the type of step size to vary the frequency and level at discrete steps.

**Parameters:**

<Mode> DECimal | USER

**DECimal**

Increases or decreases the level in steps of 10.

**USER**

Increases or decreases the value in increments, set with the command:

`:CSYNthesis:FREQuency:STEP`

`:CSYNthesis:POWer:STEP[:INCRement]`

\*RST: DECimal

**Example:** See [Chapter 14.7, "CSYNthesis Subsystem"](#), on page 454.

**Manual operation:** See ["Variation Active"](#) on page 301

**:CSYNthesis:POWer:STEP[:INCRement] <Increment>**

Sets the step width of the rotary knob and, in user-defined step mode, increases or decreases the level.

**Parameters:**

<Increment> float  
 Range: 0 to 35  
 Increment: 0.01  
 \*RST: 1

**Example:** See [Chapter 14.7, "CSYNthesis Subsystem"](#), on page 454.

**Manual operation:** See ["Variation Step"](#) on page 301

**:CSYNthesis:FREQuency:STEP <Step>**

Sets the step width of the rotary knob and, in user-defined step mode, increases or decreases the frequency.

**Parameters:**

<Step> float  
 Range: 0 to 14999E5  
 Increment: 0.001  
 \*RST: 1E6

**Example:** See [Chapter 14.7, "CSYNthesis Subsystem"](#), on page 454.

**Manual operation:** See ["Variation Step"](#) on page 301

## 14.8 DIAGnostic Subsystem

The `DIAGnostic` subsystem contains the commands used for instrument diagnosis and servicing. SCPI does not define any `DIAGnostic` commands; the commands listed here are all device-specific. All `DIAGnostic` commands are query commands which are not affected by `*RST`.



The test functions are intended for services purposes.

They are thus password-protected functions. Unlock the corresponding protection level to access them, see `:SYSTem:PROTect<ch>[:STATe]`

For more information, see R&S SMA100B Service Manual.

### Common suffixes

The following common suffixes are used in remote commands:

Suffix	Value range	Description
<code>DIAGnostic&lt;hw&gt;</code>	[1]	Optional suffix

**Example: Programming example**

The example lists the commands required to query assemblies and test points for diagnosis purposes.

```
// Query the modules available in the instrument
// and variant and revision state of a certain assembly
DIAGnostic1:BGInfo:CATalog?
// FRONT_AF,PSU300,IFB.BV,MB2_AF,...
DIAGnostic1:BGInfo? "PSU300"
// PSU300 2118.2067.02 01.00 100000

// Query the test points available in the instrument
// and trigger the measurement in a selected test point
DIAGnostic1:POINT:CATalog?
// ATT6HP_AF_DET_N,ATT6HP_AF_DET_P,ATT6HP_AF_DET_TEMP...
DIAGnostic1:MEASure:POINT? "ATT6HP_AF_DET_N"
// 0.000000V

// Query the operating hours and number of power-on so far.
DIAGnostic:INFO:OTIME?
// 112 h
DIAGnostic:INFO:POCount?
// 14
```

:DIAGnostic<hw>:BGInfo:CATalog?	460
:DIAGnostic<hw>:BGInfo?	460
:DIAGnostic:INFO:OTIME?	461
:DIAGnostic:INFO:POCount?	461
:DIAGnostic<hw>:POINT:CATalog?	462
:DIAGnostic<hw>[:MEASure]:POINT?	462

**:DIAGnostic<hw>:BGInfo:CATalog?**

Queries the names of the assemblies available in the instrument.

**Return values:**

<Catalog>                      string  
                                     List of all assemblies; the values are separated by commas  
                                     The length of the list is variable and depends on the instrument  
                                     equipment configuration.

**Example:**                      See [Example "Programming example"](#) on page 460.

**Usage:**                         Query only

**:DIAGnostic<hw>:BGInfo? [<Board>]**

Queries information on the modules available in the instrument, using the variant and revision state.



**Query parameters:**

<Board> string  
 Module name, as queried with the command :  
[DIAGnostic<hw>:BGInfo:CATalog?](#).  
 To retrieve a complete list of all modules, omit the parameter.  
 The length of the list is variable and depends on the instrument equipment configuration.

**Return values:**

<BgInfo> <Module name> <Module stock number incl. variant> <Module revision> <Module serial number>  
 List of comma-separated entries, one entry per module.  
 Each entry for one module consists of four parts that are separated by space characters.

**Example:** See [Example "Programming example"](#) on page 460.

**Usage:** Query only

**Manual operation:** See ["Assembly"](#) on page 731

**:DIAGnostic:INFO:OTIME?**

Queries the operating hours of the instrument so far.

**Return values:**

<OperationTime> integer  
 Range: 0 to INT\_MAX  
 \*RST: 0

**Example:** See [Example "Programming example"](#) on page 460.

**Usage:** Query only

**Manual operation:** See ["Operation Time / h"](#) on page 731

**:DIAGnostic:INFO:POCount?**

Queries how often the instrument has been turned on so far.

**Return values:**

<PowerOnCount> integer  
 Range: 0 to INT\_MAX  
 \*RST: 0

**Example:** See [Example "Programming example"](#) on page 460.

**Usage:** Query only

**Manual operation:** See ["Power On Count"](#) on page 732

**:DIAGnostic<hw>:POINT:CATalog?**

Queries the test points available in the instrument.

For more information, see R&S SMA100B Service Manual.

**Return values:**

<Catalog> string  
List of comma-separated values, each representing a test point

**Example:** See [Example "Programming example"](#) on page 460.

**Usage:** Query only

**:DIAGnostic<hw>[:MEASure]:POINT? <Name>**

Triggers the voltage measurement at the specified test point and returns the measured voltage.

For more information, see R&S SMA100B Service Manual.

**Query parameters:**

<Name> <test point identifier>  
Test point name, as queried with the command :  
[DIAGnostic<hw>:POINT:CATalog?](#)

**Return values:**

<Value> <value><unit>

**Example:** See [Example "Programming example"](#) on page 460.

**Usage:** Query only

## 14.9 DISPlay Subsystem

The DISPlay system contains the commands to set the power-save mode of the instrument.

### Programming Examples

#### Example: Activating screen saver mode and display update

Use the following commands to switch on the screen saver of your instrument or to automatic display. These settings are particularly useful when you control the instrument remotely.

```
// Set the wait time interval and activate the screen saver
:DISPlay:PSAVE:HOLDoff 10
:DISPlay:PSAVE:STATe ON

// Disable the display of the current frequency and level values in remote control
:DISPlay:ANNotation:ALL ON
```

```
// :DISPlay:ANNotation:FREQuency ON
// :DISPlay:ANNotation:AMPLitude ON

// Enable automatic update of the display at defined time intervals
:DISPlay:UPDate ON
```

### Example: Querying the dialog IDs, opening and closing dialogs

Use the following commands to query the dialog IDs of all currently open dialogs. The dialog ID is a prerequisite for opening and closing dialogs via the remote control.



The dialog ID is also required to define user key actions.

See [Chapter 12.2.4, "How to Assign Actions to the \[★ \(User\)\] Key"](#), on page 348.

```
// Query the dialog IDs of all open dialogs
:DISPlay:DIALog:ID?
// CEUltraDLGenSetDlg,_, $A DlgKeyRf_Rosc

// Open and close dialogs via remote control
:DISPlay:DIALog:OPEN "CEUltraDLGenSetDlg,_, $A"
:DISPlay:DIALog:OPEN "DlgKeyRf_Rosc"
:DISPlay:DIALog:CLOSe "DlgKeyRf_Rosc"
:DISPlay:DIALog:CLOSe:ALL

:DISPlay:PSAVe:HOLDoff..... 463
:DISPlay:PSAVe[:STATe]..... 464
:DISPlay:BRIGHtness..... 464
:DISPlay:BUTTOn:BRIGHtness..... 464
:DISPlay:UPDate..... 464
:DISPlay:ANNotation:AMPLitude..... 465
:DISPlay:ANNotation:FREQuency..... 465
:DISPlay:ANNotation[:ALL]..... 465
:DISPlay:DIALog:ID?..... 465
:DISPlay:DIALog:OPEN..... 466
:DISPlay:DIALog:CLOSe..... 466
:DISPlay:DIALog:CLOSe:ALL..... 467
```

---

### **:DISPlay:PSAVe:HOLDoff** <HoldoffTimeMin>

Sets the wait time for the screen saver mode of the display.

#### Parameters:

<HoldoffTimeMin>    integer  
                           Range:     1 to 60  
                           \*RST:     n.a. (factory preset: 10)  
                           Default unit: minute

**Example:**            see [Example "Activating screen saver mode and display update"](#)  
                           on page 462

**Manual operation:** See ["Wait Time"](#) on page 339

---

**:DISPlay:PSAVe[:STATe] <State>**

Activates the screen saver mode of the display.

We recommend that you use this mode to protect the display, if you operate the instrument in remote control.

To define the wait time, use the command `:DISPlay:PSAVe:HOLDoff`.

**Parameters:**

<State>                    0 | 1 | OFF | ON  
\*RST:                    n.a. (factory preset: 0)

**Example:**                See [Example "Activating screen saver mode and display update"](#) on page 462

**Manual operation:**    See ["Screen Saver"](#) on page 339

---

**:DISPlay:BRIGhtness <BRIGhtness>**

Sets the brightness of the display.

**Parameters:**

<BRIGhtness>            float  
Range:                    1.0 to 20.0  
Increment:                1.0  
\*RST:                    14.0

**Example:**                `DISPlay:BRIGhtness 14`

**Manual operation:**    See ["Display"](#) on page 339

---

**:DISPlay:BUtTon:BRIGhtness <ButtonBrightness>**

Sets the brightness of the [RF on/off] key.

**Parameters:**

<ButtonBrightness>    integer  
Range:                    1 to 20  
\*RST:                    n.a. (no preset. default: 14)

**Example:**                `DISPlay:BUtTon:BRIGhtness 15`

**Manual operation:**    See ["RF Hardkey"](#) on page 339

---

**:DISPlay:UPDate <Update>**

Activates the refresh mode of the display.

**Parameters:**

<Update>                    0 | 1 | OFF | ON  
\*RST:                    n.a. (factory preset: 1)

**Example:** See [Example "Activating screen saver mode and display update"](#) on page 462

**Manual operation:** See ["Display Update is"](#) on page 340

**:DISPlay:ANNOtation:AMPLitude** <State>

Indicates asterisks instead of the level values in the status bar.

**Parameters:**

<State> 0 | 1 | OFF | ON

\*RST: n.a. (factory preset: 1)

**Example:** See [Example "Activating screen saver mode and display update"](#) on page 462

**Manual operation:** See ["Annotation Amplitude"](#) on page 359

**:DISPlay:ANNOtation:FREQuency** <State>

Indicates asterisks instead of the frequency values in the status bar.

**Parameters:**

<State> 0 | 1 | OFF | ON

\*RST: n.a. (factory preset: 1)

**Example:** See [Example "Activating screen saver mode and display update"](#) on page 462

**Manual operation:** See ["Annotation Frequency"](#) on page 359

**:DISPlay:ANNOtation[:ALL]** <State>

Displays asterisks instead of the level and frequency values in the status bar of the instrument.

We recommend that you use this mode if you operate the instrument in remote control.

**Parameters:**

<State> 0 | 1 | OFF | ON

\*RST: 1

**Example:** See [Example "Activating screen saver mode and display update"](#) on page 462

**:DISPlay:DIALog:ID?**

Returns the dialog identifiers of the open dialogs in a string separated by blanks.

**Return values:**

<DialogIdList> <DialogID#1>< ><DialogID#2>< > ... < ><DialogID#n>

Dialog identifiers are string without blanks. Blanks are represented as \$\$.

Dialog identifiers <DialogID> are composed of two main parts: <DialogName> [<OptionalParts>]

#### <DialogName>

Meaningful information, mandatory input parameter for the commands:

:DISPlay:DIALog:OPEN on page 466

:DISPlay:DIALog:CLOSe on page 466

#### <Optional parts>

String of \$<X> values, where <X> is a character, interpreted as follows:

\$q<DialogQualifier>: optional dialog qualifier, usually the letter A or B, as displayed in the dialog title.

\$i<Instances>: comma-separated list of instance indexes, given in the order h, c, s, d, g, u, 0. Default is zero; the terminating ", 0" can be omitted.

\$t<TabIds>: comma-separated indexes or tab names; required, if a dialog is composed of several tabs.

\$x<Left>\$y<Top>\$h<Left>\$w<Top>: position and size; superfluous information.

**Example:** See [Example "Querying the dialog IDs, opening and closing dialogs"](#) on page 463

**Usage:** Query only

**Manual operation:** See ["SCPI"](#) on page 347

#### :DISPlay:DIALog:OPEN <DialogId>

Opens the specified dialog.

#### Setting parameters:

<DialogId> string

To find out the dialog identifier, use the query :DISPlay:DIALog:ID?.

The <DialogName> part of the query result is mandatory.

**Example:** See [Example "Querying the dialog IDs, opening and closing dialogs"](#) on page 463

**Usage:** Setting only

**Manual operation:** See ["SCPI"](#) on page 347

#### :DISPlay:DIALog:CLOSe <DialogId>

Closes the specified dialog.

**Setting parameters:**

<DialogId> string  
 To find out the dialog identifier, use the query `:DISPlay:DIALog:ID?`.  
 The <DialogName> part of the query result is sufficient.

**Example:** See [Example "Querying the dialog IDs, opening and closing dialogs"](#) on page 463

**Usage:** Setting only

**:DISPlay:DIALog:CLOSE:ALL**

Closes all open dialogs.

**Example:** See [Example "Querying the dialog IDs, opening and closing dialogs"](#) on page 463

**Usage:** Event

## 14.10 FORMat Subsystem

The commands in the FORMat subsystem determine the format of data returned by the R&S SMA100B to the controller. This affects all query commands that return a list of numerical data or block data, noted in the descriptions of the commands. The set data format applies to both paths.

<code>:FORMat:BORDER</code> .....	467
<code>:FORMat:SREGister</code> .....	468
<code>:FORMat[DATA]</code> .....	468

**:FORMat:BORDER <Border>**

Determines the sequence of bytes within a binary block. This only affects blocks which use the IEEE754 format internally.

**Parameters:**

<Border> NORMal | SWAPped

**NORMal**  
 Expects/sends the *least* significant byte of each IEEE754 floating-point number first and the *most* significant byte last.

**SWAPped**  
 Expects/sends the *most* significant byte of each IEEE754 floating-point number first and the *least* significant byte last.

\*RST: NORMal

**Example:** `FORM:BORD SWAP`  
 transfers the data with the most significant bit first.

**:FORMat:SREGister** <Format>

Determines the numeric format for responses of the status register.

**Parameters:**

<Format>            ASCII | BINary | HEXadecimal | OCTal

**ASCII**

Returns the register content as a decimal number.

**BINary|HEXadecimal|OCTal**

Returns the register content either as a binary, hexadecimal or octal number. According to the selected format, the number starts with #B (binary), #H (hexadecimal) or #O (octal).

\*RST:            ASCII

**Example:**

FORM:SREG HEX

returns the register content as a hexadecimal number.

**:FORMat[:DATA]** <Data>

Determines the data format the instrument uses to return data via the IEC/IEEE bus.

The instrument automatically detects the data format used by the controller, and assigns it accordingly. Data format determined by this SCPI command is in this case irrelevant.

**Parameters:**

<Data>            ASCII | PACKed

**ASCII**

Transfers numerical data as plain text separated by commas.

**PACKed**

Transfers numerical data as binary block data.

The format within the binary data depends on the command.

The various binary data formats are explained in the description of the parameter types.

\*RST:            ASCII

**Example:**

FORM ASC

transfers the data as ASCII data.

## 14.11 HCOPI Subsystem

The HCOPI subsystem contains the commands to generate and save a hard copy of the display.



To access a stored hard copy file, use the commands of the MEMM subsystem.



**Example: Store a hard copy of the display**

The following example lists commands to configure and execute a hard copy to an automatic named file.

```
:HCOpy:DEvIce:LANGUage PNG
:HCOpy:FILE:NAME:AUTO:STATe 1
// defines the output format
// sets the instrument to automatically create output file names

// *****
// Configure hard copy options, set automatic naming rules
// An automatically generated file name consists of:
// <Prefix><YYYY><MM><DD><Number>.<Format>
// *****
:HCOpy:DEvIce:LANGUage BMP
// defines output format *.bmp
:HCOpy:REGIon DIALog
// selects the region to be copied
:HCOpy:FILE:AUTO:DIR "/usb/HCOpy"
// sets destination directory of automatic named file
:HCOpy:FILE:NAME:AUTO:FILE:PREFix:STATe 1
:HCOpy:FILE:NAME:AUTO:FILE:PREFix:"hardcopy"
:HCOpy:FILE:NAME:AUTO:FILE:YEAR:STATe 1
:HCOpy:FILE:NAME:AUTO:FILE:MONTh:STATe 1
// uses automatic naming prefix
// sets automatic naming prefix to "hardcopy"
// uses automatic naming date parameters year and month

// *****
// Execute and transfer the hard copy
// *****
:HCOpy:EXECute
:HCOpy:DATA
// generates a hard copy
// transfers the hard copy to the remote client
:HCOpy:FILE:AUTO:FILE?
// queries the automatic file name
// "hardcopy1607001.bmp"
:HCOpy:FILE:AUTO:NUMBer?
// queries the number in the automatic file name
// "001"
:HCOpy:FILE:AUTO?
// queries the path and file name of the automatically generated file
// "/usb/HCOpy/hardcopy1607001.bmp"
```

**14.11.1 Hard Copy Settings**

With the following commands, you can configure the settings of a hard copy.

:HCOPY:DATA?.....	470
:HCOPY:IMAGe:FORMat.....	470
:HCOPY:DEVIce:LANGUage.....	470
:HCOPY:REGion.....	470
:HCOPY:FILE[:NAME].....	470
:HCOPY[:EXECute].....	471

---

### :HCOPY:DATA?

Transfers the hard copy data directly as a NByte stream to the remote client.

#### Return values:

<Data>                    block data

**Example:**                See [Example "Store a hard copy of the display"](#) on page 469

**Usage:**                    Query only

---

### :HCOPY:IMAGe:FORMat <Format>

### :HCOPY:DEVIce:LANGUage <Language>

Selects the graphic format for the hard copy. You can use both commands alternatively.

#### Parameters:

<Language>                BMP | JPG | XPM | PNG

\*RST:                    PNG

**Example:**                See [Example "Store a hard copy of the display"](#) on page 469

**Manual operation:**    See ["Format"](#) on page 332

---

### :HCOPY:REGion <Region>

Selects the area to be copied.

You can create a snapshot of the screen or an active dialog.

#### Parameters:

<Region>                    ALL | DIALog

\*RST:                    ALL

**Example:**                See [Example "Store a hard copy of the display"](#) on page 469

**Manual operation:**    See ["Region"](#) on page 333

---

### :HCOPY:FILE[:NAME] <Name>

Determines the file name and path to save the hard copy, provided automatic naming is disabled.

**Note:** If you have enabled automatic naming, the instrument automatically generates the file name and directory, see [Chapter 14.11.2, "Automatic Naming"](#), on page 471.

**Parameters:**

<Name> string

**Example:** See [Example "Store a hard copy of the display"](#) on page 469

**Manual operation:** See ["File..."](#) on page 332

**:HCOPY[:EXECute]**

Generates a hard copy of the current display. The output destination is a file.

**Example:** See [Example "Store a hard copy of the display"](#) on page 469

**Usage:** Event

**Manual operation:** See ["Save"](#) on page 332

### 14.11.2 Automatic Naming

Use the following commands to automatically assign a file name.

<a href="#">:HCOPY:FILE[:NAME]:AUTO?</a> .....	471
<a href="#">:HCOPY:FILE[:NAME]:AUTO:DIRectory</a> .....	471
<a href="#">:HCOPY:FILE[:NAME]:AUTO:DIRectory:CLear</a> .....	472
<a href="#">:HCOPY:FILE[:NAME]:AUTO:FILE?</a> .....	472
<a href="#">:HCOPY:FILE[:NAME]:AUTO:STATe</a> .....	472
<a href="#">:HCOPY:FILE[:NAME]:AUTO[:FILE]:DAY:STATe</a> .....	472
<a href="#">:HCOPY:FILE[:NAME]:AUTO[:FILE]:MONTh:STATe</a> .....	472
<a href="#">:HCOPY:FILE[:NAME]:AUTO[:FILE]:YEAR:STATe</a> .....	472
<a href="#">:HCOPY:FILE[:NAME]:AUTO[:FILE]:NUMBer?</a> .....	473
<a href="#">:HCOPY:FILE[:NAME]:AUTO[:FILE]:PREFix</a> .....	473
<a href="#">:HCOPY:FILE[:NAME]:AUTO[:FILE]:PREFix:STATe</a> .....	473

**:HCOPY:FILE[:NAME]:AUTO?**

Queries path and file name of the hardcopy file, if you have enabled *Automatic Naming*.

**Return values:**

<Auto> string

**Example:** See [Example "Store a hard copy of the display"](#) on page 469

**Usage:** Query only

**:HCOPY:FILE[:NAME]:AUTO:DIRectory <Directory>**

Determines the path to save the hard copy, if you have enabled *Automatic Naming*.

If the directory does not yet exist, the instrument automatically creates a new directory, using the instrument name and `/var/user/` by default.

**Parameters:**

<Directory> string  
 \*RST: /var/user/

**Example:** See [Example "Store a hard copy of the display"](#) on page 469

**Manual operation:** See ["Path..."](#) on page 334

**:HCOPY:FILE[:NAME]:AUTO:DIRectory:CLEar**

Deletes all files with extensions \*.bmp, \*.jpg, \*.png and \*.xpm in the directory set for automatic naming.

**Example:** See [Example "Store a hard copy of the display"](#) on page 469

**Usage:** Event

**Manual operation:** See ["Clear Path"](#) on page 334

**:HCOPY:FILE[:NAME]:AUTO:FILE?**

Queries the name of the automatically named hard copy file.

An automatically generated file name consists of:

<Prefix><YYYY><MM><DD><Number>.<Format>.

You can activate each component separately, to individually design the file name.

**Return values:**

<File> string

**Example:** See [Example "Store a hard copy of the display"](#) on page 469.

**Usage:** Query only

**:HCOPY:FILE[:NAME]:AUTO:STATe <State>**

Activates automatic naming of the hard copy files.

**Parameters:**

<State> 0 | 1 | OFF | ON  
 \*RST: 1

**Example:** See [Example "Store a hard copy of the display"](#) on page 469

**Manual operation:** See ["Automatic Naming"](#) on page 333

**:HCOPY:FILE[:NAME]:AUTO[:FILE]:DAY:STATe <State>****:HCOPY:FILE[:NAME]:AUTO[:FILE]:MONTH:STATe <State>****:HCOPY:FILE[:NAME]:AUTO[:FILE]:YEAR:STATe <State>**

Uses the date parameters (year, month or day) for the automatic naming. You can activate each of the date parameters separately.

**Parameters:**

<State> 0 | 1 | OFF | ON  
 \*RST: 1

**Example:** See [Example "Store a hard copy of the display"](#) on page 469

**Manual operation:** See ["Prefix, Year, Month, Day"](#) on page 334

**:HCOPY:FILE[:NAME]:AUTO[:FILE]:NUMBER?**

Queries the number that is used as part of the file name for the next hard copy in automatic mode.

At the beginning, the count starts at 0. The R&S SMA100B searches the specified output directory for the highest number in the stored files. It increases this number by one to achieve a unique name for the new file.

The resulting auto number is appended to the resulting file name with at least three digits.

**Return values:**

<Number> integer  
 Range: 0 to 999999  
 \*RST: 0

**Example:** See [Example "Store a hard copy of the display"](#) on page 469

**Usage:** Query only

**Manual operation:** See ["Current Auto Number"](#) on page 334

**:HCOPY:FILE[:NAME]:AUTO[:FILE]:PREFIX <Prefix>**

**:HCOPY:FILE[:NAME]:AUTO[:FILE]:PREFIX:STATE <State>**

Uses the prefix for the automatic generation of the file name, provided `PREF:STAT` is activated.

**Parameters:**

<State> 0 | 1 | OFF | ON  
 \*RST: 1

**Example:** See [Example "Store a hard copy of the display"](#) on page 469

**Manual operation:** See ["Prefix, Year, Month, Day"](#) on page 334

## 14.12 KBOard Subsystem

The KBOard subsystem contains the commands to set a connected keyboard.

[:KBOard:LAYout](#).....474

**:KBOard:LAYout** <Layout>

Selects the language for an external keyboard and assigns the keys accordingly.

**Parameters:**

<Layout> CHINese | DANish | DUTCh | DUTBe | ENGLish | ENGUk |  
FINNish | FRENch | FREBe | FRECa | GERMan | ITALian |  
JAPAnese | KORean | NORWegian | PORTuguese | RUSSian |  
SPANish | SWEDish | ENGUS  
\*RST: n.a. (factory preset: ENGLish)

**Example:**

```
:KBOard:LAYout US
// activates American keyboard
```

**Manual operation:** See "[USB Keyboard > Layout](#)" on page 339

## 14.13 OUTPut Subsystem

In the OUTPut subsystem, you can configure the output signals.

The LF output signal is defined with the commands of the [Chapter 14.16.6, "SOURce:LFOutput Subsystem"](#), on page 632 system.

**Common suffixes**

The following common suffixes are used in remote commands:

Suffix	Value range	Description
OUTPut<hw>	[1]	Optional suffix

:OUTPut:ALL[:STATe].....	474
:OUTPut<hw>[:STATe].....	475
:OUTPut<hw>[:STATe]:PON.....	475
:OUTPut<hw>:AMODE.....	475
:OUTPut<hw>:FILTer:MODE.....	476
:OUTPut<hw>:IMPedance?.....	476
:OUTPut:FPRoportional:SCALE.....	476
:OUTPut:USER:MARKer.....	477
:OUTPut<hw>:AFIXed:RANGe:LOWer?.....	477
:OUTPut<hw>:AFIXed:RANGe:UPPer?.....	477
:OUTPut<hw>:PROTection:CLEar.....	477
:OUTPut<hw>:PROTection:TRIPped?.....	478

**:OUTPut:ALL[:STATe]** <State>

Activates the RF output signal of the instrument.

**Parameters:**

<State> 0 | 1 | OFF | ON  
\*RST: n.a. (factory preset: 0)

**Example:**           OUTPut:ALL:STATe 0

---

**:OUTPut<hw>[:STATe] <State>**

Activates the RF output signal.

**Parameters:**

<State>           0 | 1 | OFF | ON  
\*RST:            0

**Example:**           OUTP ON  
Activates the RF output.

**Manual operation:** See "[RF State/RF ON](#)" on page 67

---

**:OUTPut<hw>[:STATe]:PON <Pon>**

Defines the state of the RF output signal when the instrument is switched on.

**Parameters:**

<Pon>            OFF | UNCHanged  
\*RST:            n.a. (factory preset: UNCHanged)

**Example:**           OUTP:PON OFF  
The RF output is deactivated when the instrument is switched on.

**Manual operation:** See "[Power-On State](#)" on page 340

---

**:OUTPut<hw>:AMODE <AMode>**

Sets the step attenuator mode at the RF output.

**Parameters:**

<AMode>           AUTO | FIXEd

**AUTO**

The step attenuator adjusts the level settings automatically, within the full variation range.

**FIXEd**

The step attenuator and amplifier stages are fixed at the current position, providing level settings with constant output VSWR. The resulting variation range is calculated according to the position.

\*RST:            AUTO

**Example:**           SOURce:POWer:ALC:STATe 1  
OUTPut:AMODE FIXEd

**Manual operation:** See "[Mode](#)" on page 213

---

**:OUTPut<hw>:FILTer:MODE <Mode>**

Activates low harmonic filter or enables its automatic switching.

**Parameters:**

<Mode> ON | AUTO | 1

**ON|1**

Ensures best low harmonics performance but decreases the level range

**AUTO**

Applies an automatically selected harmonic filter that fits to the current level setting.

\*RST: AUTO

**Example:**

OUTPut:FILTer:MODE AUTO

**Manual operation:** See "[Harmonic Filter](#)" on page 77

---

**:OUTPut<hw>:IMPedance?**

Queries the impedance of the RF outputs.

**Return values:**

<Impedance> G1K | G50 | G10K

\*RST: G50

**Example:**

OUTP:IMP?

queries the impedance of RF output.

Response: 50

the impedance is 50 ohms

**Usage:**

Query only

**Manual operation:** See "[RF output impedance](#)" on page 67

---

**:OUTPut:FPRoportional:SCALE <OutpSelScale>**

Selects the mode the voltage is supplied depending on the frequency.

The R&S SMA100B supplies the signal at the V/GHz X-Axis connector.

**Parameters:**

<OutpSelScale> S0V25 | S0V5 | S1V0 | XAXis

**S0V25|S0V5|S1V0**

Supplies the voltage proportional to the set frequency, derived from the selected setting.

**XAXis**

Supplies a voltage range from 0 V to 10 V proportional to the frequency sweep range, set with [ :SOURce<hw> ] :FREQuency:START and [ :SOURce<hw> ] :FREQuency:STOP.

\*RST: S0V25



**Options:** R&S SMAB-B28

**Manual operation:** See " [V/GHz / X-Axis](#) " on page 196

**:OUTPut:USER:MARKer** <SelUserMarker>

Selects the signal for output at the Marker User1 connector.

**Parameters:**

<SelUserMarker> MARK | USER

**MARK**

Assigns a marker signal to the output.

**USER**

Intended for future use.

\*RST: MARK

**Options:** R&S SMAB-B28

**Manual operation:** See " [Marker / User](#) " on page 197

**:OUTPut<hw>:AFIXed:RANGe:LOWer?**

**:OUTPut<hw>:AFIXed:RANGe:UPPer?**

Queries the settable minimum/maximum value in mode :OUTPut:AMODE FIXed, i.e. when the attenuator is not being adjusted.

See :OUTPut<hw>:AMODE on page 475

**Return values:**

<Upper> float  
 Increment: 0.01  
 Default unit: dBm

**Example:**

```
OUTPut1:AMODE FIXed
OUTPut1:AFIXed:RANGe:UPPer?
// -27
OUTPut1:AFIXed:RANGe:LOW?
// -50
```

**Usage:** Query only

**Manual operation:** See " [Level Range](#) " on page 213

**:OUTPut<hw>:PROTection:CLEar**

Resets the protective circuit after it has been tripped.

To define the output state, use the command :OUTPut<hw>[:STATe].

**Example:**

```
OUTP:PROT:CLE
Resets the protective circuit of the RF output.
```

**Usage:** Event

**Manual operation:** See "Overload" on page 214

---

**:OUTPut<hw>:PROTection:TRIPped?**

Queries the state of the protective circuit.

**Return values:**

<Tripped>            0 | 1 | OFF | ON  
 \*RST:                0

**Example:**

OUTP:PROT:TRIP  
 queries the state of the protective circuit of the RF output.  
 Response: 0  
 the protective circuit has not tripped.

**Usage:**                Query only

**Manual operation:** See "Overload" on page 214

## 14.14 Power Sensor Measurement Subsystems

The power sensor measurement uses several subsystems:

- The CALCulate subsystem is used to configure the time gated measurements in power analysis.
- The DISPLAY subsystem is used to configure the diagram appearance.
- The INITiate command switches the local state of the continuous power measurement on and off.
- The READ system is used to start and to retrieve the measurement result of the power viewer measurement.
- The SENSE subsystem contains the commands for configuring the power viewer and power analysis measurements with power sensors connected to the generator. Up to four sensors can be connected to the signal generator.
- The TRACE subsystem is used to configure the traces in power analysis and to retrieve the measurement results.

### Power Viewer

The power viewer measurement is started with the READ command, this command also retrieves the measurement results.

The sensors are distinguished by the suffix under SENSE:

- Power sensor connected to the SENSOR port = SENSE[1]
- First Power sensor connected to the USB interface = SENSE2
- Second Power sensor connected to the USB interface = SENSE3
- Third Power sensor connected to the USB interface = SENSE4

### Power and Pulse Data Analysis, Gated Measurements (option R&S SMA100B-K28)

The power analysis measurement commands are subsumed under the `SENSe[:POWER]:SWEep:...` commands. Three measurement modes are available: Frequency, Power and Time.

The power analysis measurement is started with the `SENSe[:POWER]:SWEep:INITiate` command and the measurement result retrieved with the `TRACe[:POWER]:SWEep:...` commands.

The four sensors are distinguished by the suffix at the second key word `SENSe`.

The time gate settings are performed using the `CALCulate[:POWER]:SWEep:...` commands.

The measurement diagram and results can be stored in a hardcopy with the `SENSe[:POWER]:SWEep:HCOpy:...` commands.

General parameter and measurement settings are valid for all connected sensors, therefore, no suffix is used in these commands.

#### 14.14.1 CALCulate Subsystem

<code>:CALCulate[:POWER]:SWEep:FREQuency:MATH&lt;ch&gt;:STATe</code> .....	479
<code>:CALCulate[:POWER]:SWEep:FREQuency:MATH&lt;ch&gt;:SUBTract</code> .....	480
<code>:CALCulate[:POWER]:SWEep:POWer:MATH&lt;ch&gt;:STATe</code> .....	480
<code>:CALCulate[:POWER]:SWEep:POWer:MATH&lt;ch&gt;:SUBTract</code> .....	480
<code>:CALCulate[:POWER]:SWEep:TIME:GATE&lt;ch&gt;:AVERAge?</code> .....	481
<code>:CALCulate[:POWER]:SWEep:TIME:GATE&lt;ch&gt;:FEED</code> .....	481
<code>:CALCulate[:POWER]:SWEep:TIME:GATE&lt;ch&gt;:MAXimum?</code> .....	481
<code>:CALCulate[:POWER]:SWEep:TIME:GATE&lt;ch&gt;:START</code> .....	482
<code>:CALCulate[:POWER]:SWEep:TIME:GATE&lt;ch&gt;:STOP</code> .....	482
<code>:CALCulate[:POWER]:SWEep:TIME:GATE&lt;ch&gt;:STATe</code> .....	482
<code>:CALCulate[:POWER]:SWEep:TIME:MATH&lt;ch&gt;:STATe</code> .....	483
<code>:CALCulate[:POWER]:SWEep:TIME:MATH&lt;ch&gt;:SUBTract</code> .....	483

---

#### `:CALCulate[:POWER]:SWEep:FREQuency:MATH<ch>:STATe <State>`

Activates the trace mathematics mode for "Frequency" measurement. This feature enables you to calculate the difference between the measurement values of two traces. For further calculation, a math result can also be assigned to a trace.

##### Parameters:

`<State>`                    0 | 1 | OFF | ON  
`*RST:`                    0

##### Example:

`CALC:POW:SWE:FREQ:MATH2:STATe`  
 Switches on math mode in trace 2.

##### Options:

R&S SMAB-K28

##### Manual operation:

See "[Mathematics - Trace Power Analysis](#)" on page 248

**:CALCulate[:POWer]:SWEep:FREQuency:MATH<ch>:SUBTract <Subtract>**

Subtracts the operands 1 and 2 and assigns the result to the selected trace in "Frequency" measurement mode.

**Parameters:**

<Subtract> T1T1 | T1T2 | T1T3 | T1T4 | T1REF | T2T1 | T2T2 | T2T3 | T2T4 |  
T2REF | T3T1 | T3T2 | T3T3 | T3T4 | T3REF | T4T1 | T4T2 |  
T4T3 | T4T4 | T4REF

**Example:**

CALC:POW:SWE:FREQ:MATH4:SUBT T2REF

Subtracts the Reference and Trace 2, and assigns the result to Trace 4. The resulting curve is shown in the diagram.

**Options:**

R&S SMAB-K28

**Manual operation:** See "[Mathematics - Trace Power Analysis](#)" on page 248

**:CALCulate[:POWer]:SWEep:POWer:MATH<ch>:STATe <State>**

Activates the trace mathematics mode for "Power" measurement. This feature enables you to calculate the difference between the measurement values of two traces. For further calculation, a math result can also be assigned to a trace.

**Parameters:**

<State> 0 | 1 | OFF | ON  
\*RST: 0

**Example:**

CALC:POW:SWE:POW:MATH2:STATe

Switches on math mode in trace 2.

**Options:**

R&S SMAB-K28

**Manual operation:** See "[Mathematics - Trace Power Analysis](#)" on page 248

**:CALCulate[:POWer]:SWEep:POWer:MATH<ch>:SUBTract <Subtract>**

Subtracts the operands 1 and 2 and assigns the result to the selected trace in "Power" measurement mode.

**Parameters:**

<Subtract> T1T1 | T1T2 | T1T3 | T1T4 | T1REF | T2T1 | T2T2 | T2T3 | T2T4 |  
T2REF | T3T1 | T3T2 | T3T3 | T3T4 | T3REF | T4T1 | T4T2 |  
T4T3 | T4T4 | T4REF

**Example:**

CALC:POW:SWE:POW:MATH4:SUBT T2REF

Subtracts the Reference and Trace 2, and assigns the result to Trace 4. The resulting curve is shown in the diagram.

**Options:**

R&S SMAB-K28

**Manual operation:** See "[Mathematics - Trace Power Analysis](#)" on page 248

**:CALCulate[:POWer]:SWEep:TIME:GATE<ch>:AVERage?**

Queries the average power value of the time gated measurement.

**Return values:**

<Average> float  
 Range: -1000 to 1000  
 Increment: 1E-12  
 \*RST: 0

**Example:**

SENS:SWE:MODE TIME  
 Activates time mode for power analysis.  
 CALC:SWE:TIME:GATE:STAT ON  
 Activates time gated measurement.  
 SENS:SWE:INIT  
 Activates a single power analysis measurement.  
 CALC:SWE:TIME:GATE2:AVER?  
 Queries the average power in time gate 2 for trace 1 (=default).

**Usage:** Query only

**Options:** Option R&S SMAB-K28

**Manual operation:** See " [State - Gate](#) " on page 270

**:CALCulate[:POWer]:SWEep:TIME:GATE<ch>:FEED <Feed>**

Selects the trace for time gated measurement. Both gates are assigned to the same trace.

**Parameters:**

<Feed> TRAC1 | TRAC2 | TRAC3 | TRACe1 | TRACe2 | TRACe3 |  
 TRAC4 | TRACe4  
 \*RST: TRAC1

**Example:**

CALC:SWE:TIME:GATE:FEED TRAC2  
 Assigns the gates to trace 2.

**Options:** Option R&S SMAB-K28

**Manual operation:** See " [Trace - Gate](#) " on page 269

**:CALCulate[:POWer]:SWEep:TIME:GATE<ch>:MAXimum?**

Queries the average power value of the time gated measurement.

**Return values:**

<Maximum> float  
 Range: -1000 to 1000  
 Increment: 1E-12  
 \*RST: 0

**Example:**           SENS : SWE : MODE TIME  
 Activates time mode for power analysis.  
 CALC : SWE : TIME : GATE : STAT ON  
 Activates time gated measurement.  
 SENS : SWE : INIT  
 Activates a single power analysis measurement.  
 CALC : SWE : TIME : GATE2 : MAX?  
 Queries the peak power in time gate 2 for trace 1 (=default).

**Usage:**            Query only

**Options:**         Option R&S SMAB-K28

**Manual operation:** See " [State - Gate](#) " on page 270

**:CALCulate[:POWer]:SWEep:TIME:GATE<ch>:STARt <Start>**  
**:CALCulate[:POWer]:SWEep:TIME:GATE<ch>:STOP <Stop>**

Sets the start time of the selected gate. Insert value and unit.

**Parameters:**

<Stop>               float  
 Increment:   1E-12  
 \*RST:         Start/Stop: 5/15 (Gate1), 25/35 (Gate2)

**Example:**           CALC : SWE : TIME : GATE2 : STAR 20us  
 Sets a start time of 20 us for gate 2.  
 CALC : SWE : TIME : GATE2 : STOP 30us  
 Sets a stop time of 30us for gate 2.

**Options:**         Option R&S SMAB-K28

**Manual operation:** See " [Start / Stop - Gate](#) " on page 270

**:CALCulate[:POWer]:SWEep:TIME:GATE<ch>:STATe <State>**

Activates the gate settings for the selected trace. The measurement is started with command SENS : POW : INIT. Both gates are active at one time.

**Parameters:**

<State>             0 | 1 | OFF | ON  
 \*RST:             0

**Example:**           CALC : SWE : TIME : GATE : STAT ON  
 Enables time gated measurement.

**Options:**         Option R&S SMAB-K28

**Manual operation:** See " [State - Gate](#) " on page 270

**:CALCulate[:POWER]:SWEep:TIME:MATH<ch>:STATe <State>**

Activates the trace mathematics mode for "Time" measurement. This feature enables you to calculate the difference between the measurement values of two traces. For further calculation, a math result can also be assigned to a trace.

**Parameters:**

<State> 0 | 1 | OFF | ON  
\*RST: 0

**Example:**

CALC:POW:SWE:TIME:MATH1:STATe  
Switches on math mode.

**Options:**

R&S SMAB-K28

**Manual operation:** See " [Mathematics - Trace Power Analysis](#) " on page 248

**:CALCulate[:POWER]:SWEep:TIME:MATH<ch>:SUBTract <Subtract>**

Subtracts the operands 1 and 2 and assigns the result to the selected trace in "Time" measurement mode.

**Parameters:**

<Subtract> T1T1 | T1T2 | T1T3 | T1T4 | T1REF | T2T1 | T2T2 | T2T3 | T2T4 |  
T2REF | T3T1 | T3T2 | T3T3 | T3T4 | T3REF | T4T1 | T4T2 |  
T4T3 | T4T4 | T4REF

**Example:**

CALC:POW:SWE:TIME:MATH4:SUBT T2REF  
Subtracts the Reference and Trace 2, and assigns the result to Trace 4. The resulting curve is shown in the diagram.

**Options:**

R&S SMAB-K28

**Manual operation:** See " [Mathematics - Trace Power Analysis](#) " on page 248

## 14.14.2 DISPlay Subsystem

[:DISPlay\[:WINDow\]\[:POWER\]:SWEep:BACKground:COLor.....](#) 483

[:DISPlay\[:WINDow\]\[:POWER\]:SWEep:GRID:STATe.....](#) 484

**:DISPlay[:WINDow][:POWER]:SWEep:BACKground:COLor <Color>**

Defines the background color of the measurement diagram. The selected color applies also to the hardcopy of the diagram.

**Parameters:**

<Color> BLACK | WHITe  
\*RST: BLACK

**Example:**

DISP:SWE:BACK:COL WHIT  
The measurement is indicated with a white background.

**Manual operation:** See " [Background Color - Power Analysis](#) " on page 258

---

```
:DISPlay[:WINDow][:POWer]:SWEep:GRID:STATe <State>
```

Indicates a grid in the diagram.

**Parameters:**

```
<State>          0 | 1 | OFF | ON
*RST:           1
```

**Example:**

```
DISP:SWE:GRID:STAT OFF
Deactivates the indication of a grid in the diagram area.
```

**Manual operation:** See " [Show Grid - Power Analysis](#) " on page 258

### 14.14.3 INITiate Command

---

```
:INITiate<hw>[:POWer]:CONTInuous <Continuous>
```

Switches the local state of the continuous power measurement by R&S NRP power sensors on and off. Switching off local state enhances the measurement performance during remote control.

The remote measurement is triggered with `:READ<ch>[:POWer]?`. This command also returns the measurement results. The local state is not affected, measurement results can be retrieved with local state on or off.

**Parameters:**

```
<Continuous>    0 | 1 | OFF | ON
*RST:           0
```

**Example:**

```
INIT1:CONT ON
Switches local state of continuous power measurement on.
```

**Manual operation:** See " [State](#) " on page 237

### 14.14.4 SENSE SWEep Subsystem

<code>:SENSe&lt;ch&gt;[:POWer]:SWEep:FREQUency[:SENSor]:OFFSet</code> .....	486
<code>:SENSe&lt;ch&gt;[:POWer]:SWEep:FREQUency[:SENSor]:OFFSet:STATe</code> .....	487
<code>:SENSe&lt;ch&gt;[:POWer]:SWEep:FREQUency[:SENSor]:SRANge:START</code> .....	487
<code>:SENSe&lt;ch&gt;[:POWer]:SWEep:FREQUency[:SENSor]:SRANge:STOP</code> .....	487
<code>:SENSe&lt;ch&gt;[:POWer]:SWEep:FREQUency[:SENSor]:SRANge[:STATe]</code> .....	488
<code>:SENSe&lt;ch&gt;[:POWer]:SWEep:POWer[:SENSor]:OFFSet</code> .....	488
<code>:SENSe&lt;ch&gt;[:POWer]:SWEep:POWer[:SENSor]:OFFSet:STATe</code> .....	489
<code>:SENSe&lt;ch&gt;[:POWer]:SWEep:POWer[:SENSor]:SFRequency</code> .....	489
<code>:SENSe&lt;ch&gt;[:POWer]:SWEep:POWer[:SENSor]:SFRequency:STATe</code> .....	489
<code>:SENSe&lt;ch&gt;[:POWer]:SWEep:TIME[:SENSor]:OFFSet</code> .....	490
<code>:SENSe&lt;ch&gt;[:POWer]:SWEep:TIME[:SENSor]:OFFSet:STATe</code> .....	490
<code>:SENSe&lt;ch&gt;[:POWer]:SWEep:TIME[:SENSor]:PULSe:STATe</code> .....	490
<code>:SENSe&lt;ch&gt;[:POWer]:SWEep:TIME[:SENSor]:PULSe:THReshold:BASE</code> .....	491



## Power Sensor Measurement Subsystems

:SENSe<ch>[:POWer]:SWEep:TIME[:SENSor]:PULSe:THReshold:POWer:HREFerence.....	491
:SENSe<ch>[:POWer]:SWEep:TIME[:SENSor]:PULSe:THReshold:POWer:LREFerence.....	491
:SENSe<ch>[:POWer]:SWEep:TIME[:SENSor]:PULSe:THReshold:POWer:REFerence.....	492
:SENSe<ch>[:POWer]:SWEep:TIME[:SENSor]:SFRequency.....	492
:SENSe<ch>[:POWer]:SWEep:TIME[:SENSor]:SFRequency:STATe.....	492
:SENSe<ch>[:POWer]:SWEep:TIME[:SENSor]:TRIGger:AUTO.....	493
:SENSe<ch>[:POWer]:SWEep:TIME[:SENSor]:TRIGger:DTIME.....	493
:SENSe<ch>[:POWer]:SWEep:TIME[:SENSor]:TRIGger:HYSteresis.....	493
:SENSe<ch>[:POWer]:SWEep:TIME[:SENSor]:TRIGger:LEVel.....	494
:SENSe<ch>[:POWer]:SWEep:TIME[:SENSor]:TRIGger:SLOPe.....	494
:SENSe<ch>[:POWer]:SWEep:TIME[:SENSor]:TRIGger:SOURce.....	494
:SENSe<ch>[:POWer]:ZERO.....	494
:SENSe[:POWer]:SWEep:ABORT.....	495
:SENSe[:POWer]:SWEep:FREQuency:REFerence:DATA:COpy.....	495
:SENSe[:POWer]:SWEep:FREQuency:REFerence:DATA:POINts?.....	495
:SENSe[:POWer]:SWEep:FREQuency:REFerence:DATA:XVALues.....	495
:SENSe[:POWer]:SWEep:FREQuency:REFerence:DATA:YVALues.....	496
:SENSe[:POWer]:SWEep:FREQuency:RMODE.....	496
:SENSe[:POWer]:SWEep:FREQuency:SPACing[:MODE].....	496
:SENSe[:POWer]:SWEep:FREQuency:START.....	496
:SENSe[:POWer]:SWEep:FREQuency:STEPS.....	497
:SENSe[:POWer]:SWEep:FREQuency:STOP.....	497
:SENSe[:POWer]:SWEep:FREQuency:TIMing[:MODE].....	497
:SENSe[:POWer]:SWEep:FREQuency:YSCale:AUTO.....	498
:SENSe[:POWer]:SWEep:FREQuency:YSCale:AUTO:RESet.....	498
:SENSe[:POWer]:SWEep:FREQuency:YSCale:MAXimum.....	498
:SENSe[:POWer]:SWEep:FREQuency:YSCale:MINimum.....	499
:SENSe[:POWer]:SWEep:HCOPy:DATA?.....	499
:SENSe[:POWer]:SWEep:HCOPy:DEvice.....	500
:SENSe[:POWer]:SWEep:HCOPy:DEvice:LANGUage.....	501
:SENSe[:POWer]:SWEep:HCOPy:DEvice:LANGUage:CSV:DPOint.....	501
:SENSe[:POWer]:SWEep:HCOPy:DEvice:LANGUage:CSV:HEADer.....	501
:SENSe[:POWer]:SWEep:HCOPy:DEvice:LANGUage:CSV:ORientation.....	502
:SENSe[:POWer]:SWEep:HCOPy:DEvice:LANGUage:CSV[:COLumn]:SEPArator.....	502
:SENSe[:POWer]:SWEep:HCOPy:DEvice:SIZE.....	502
:SENSe[:POWer]:SWEep:HCOPy:FILE[:NAME].....	503
:SENSe[:POWer]:SWEep:HCOPy:FILE[:NAME]:AUTO:DIRectory.....	503
:SENSe[:POWer]:SWEep:HCOPy:FILE[:NAME]:AUTO:DIRectory:CLear.....	503
:SENSe[:POWer]:SWEep:HCOPy:FILE[:NAME]:AUTO:FILE?.....	504
:SENSe[:POWer]:SWEep:HCOPy:FILE[:NAME]:AUTO:STATe.....	504
:SENSe[:POWer]:SWEep:HCOPy:FILE[:NAME]:AUTO[:FILE]:DAY?.....	504
:SENSe[:POWer]:SWEep:HCOPy:FILE[:NAME]:AUTO[:FILE]:DAY:STATe.....	505
:SENSe[:POWer]:SWEep:HCOPy:FILE[:NAME]:AUTO[:FILE]:MONTH?.....	505
:SENSe[:POWer]:SWEep:HCOPy:FILE[:NAME]:AUTO[:FILE]:MONTH:STATe.....	505
:SENSe[:POWer]:SWEep:HCOPy:FILE[:NAME]:AUTO[:FILE]:NUMBER?.....	506
:SENSe[:POWer]:SWEep:HCOPy:FILE[:NAME]:AUTO[:FILE]:PREFix.....	506
:SENSe[:POWer]:SWEep:HCOPy:FILE[:NAME]:AUTO[:FILE]:PREFix:STATe.....	506
:SENSe[:POWer]:SWEep:HCOPy:FILE[:NAME]:AUTO[:FILE]:YEAR?.....	506
:SENSe[:POWer]:SWEep:HCOPy:FILE[:NAME]:AUTO[:FILE]:YEAR:STATe.....	507
:SENSe[:POWer]:SWEep:HCOPy[:EXECute].....	507

:SENSe[:POWer]:SWEep:INITiate.....	507
:SENSe[:POWer]:SWEep:MODE.....	507
:SENSe[:POWer]:SWEep:POWer:REFerence:DATA:COpy.....	508
:SENSe[:POWer]:SWEep:POWer:REFerence:DATA:POINts?.....	508
:SENSe[:POWer]:SWEep:POWer:REFerence:DATA:XVALues.....	508
:SENSe[:POWer]:SWEep:POWer:REFerence:DATA:YVALues.....	508
:SENSe[:POWer]:SWEep:POWer:RMODe.....	509
:SENSe[:POWer]:SWEep:POWer:SPACing[:MODe].....	509
:SENSe[:POWer]:SWEep:POWer:STARt.....	509
:SENSe[:POWer]:SWEep:POWer:STEPs.....	509
:SENSe[:POWer]:SWEep:POWer:STOP.....	510
:SENSe[:POWer]:SWEep:POWer:TIMing[:MODe].....	510
:SENSe[:POWer]:SWEep:POWer:YSCale:AUTO.....	510
:SENSe[:POWer]:SWEep:POWer:YSCale:AUTO:RESet.....	511
:SENSe[:POWer]:SWEep:POWer:YSCale:MAXimum.....	511
:SENSe[:POWer]:SWEep:POWer:YSCale:MINimum.....	512
:SENSe[:POWer]:SWEep:RMODe.....	512
:SENSe[:POWer]:SWEep:TIME:AVERage[:COUnT].....	512
:SENSe[:POWer]:SWEep:TIME:REFerence:DATA:COpy.....	513
:SENSe[:POWer]:SWEep:TIME:REFerence:DATA:POINts?.....	513
:SENSe[:POWer]:SWEep:TIME:REFerence:DATA:XVALues.....	513
:SENSe[:POWer]:SWEep:TIME:REFerence:DATA:YVALues.....	513
:SENSe[:POWer]:SWEep:TIME:RMODe.....	514
:SENSe[:POWer]:SWEep:TIME:SPACing[:MODe].....	514
:SENSe[:POWer]:SWEep:TIME:STARt.....	514
:SENSe[:POWer]:SWEep:TIME:STEPs.....	514
:SENSe[:POWer]:SWEep:TIME:STOP.....	515
:SENSe[:POWer]:SWEep:TIME:TEVents.....	515
:SENSe[:POWer]:SWEep:TIME:YSCale:AUTO.....	515
:SENSe[:POWer]:SWEep:TIME:YSCale:AUTO:RESet.....	516
:SENSe[:POWer]:SWEep:TIME:YSCale:MAXimum.....	516
:SENSe[:POWer]:SWEep:TIME:YSCale:MINimum.....	517

---

### :SENSe<ch>[:POWer]:SWEep:FREQuency[:SENSor]:OFFSet <Offset>

Defines the level offset at the sensor input in dB. Activate the offset with the command `:SENSe<ch>[:POWer]:SWEep:FREQuency[:SENSor]:OFFSet:STATe` on page 487.

#### Parameters:

<Offset>	float
Range:	-100 to 100
Increment:	0.01
*RST:	0

#### Example:

```
SENS2:SWE:FREQ:OFFS -3dB
Defines a level offset of -3 dB.
SENS2:SWE:FREQ:OFFS:STAT ON
Activates the specified level offset.
```

#### Options:

Option R&S SMAB-K28

**Manual operation:** See " [Level Offset - Power Analysis](#) " on page 255

---

**:SENSe<ch>[:POWer]:SWEep:FREQuency[:SENSor]:OFFSet:STATe <State>**

Activates a level offset at the sensor input. Define the appropriate value with the command `:SENSe<ch>[:POWer]:SWEep:FREQuency[:SENSor]:OFFSet` on page 486.

**Parameters:**

<State>            0 | 1 | OFF | ON  
 \*RST:            0

**Example:**            `SENS2:SWE:FREQ:OFFS:STAT ON`  
 Activates the specified level offset.

**Options:**            Option R&S SMAB-K28

**Manual operation:** See " [Level Offset State- Power Analysis](#) " on page 255

---

**:SENSe<ch>[:POWer]:SWEep:FREQuency[:SENSor]:SRANge:STARt <Start>**

Sets the start frequency for the frequency power analysis with separate frequencies.

**Parameters:**

<Start>            integer  
 Range:            0 to 1E12  
 \*RST:            1E6

**Example:**            `SENS2:SWE:FREQ:SENS:SRAN:STAT ON`  
 Activates use of a separate frequency range for frequency versus power measurement for sensor 2.  
`SENS2:SWE:FREQ:SENS:STAR 2.0GHZ`  
 Sets a sweep start at 2 GHz irrespective of the current signal generator frequency settings.

**Manual operation:** See " [Min Frequency - Power Analysis](#) " on page 256

---

**:SENSe<ch>[:POWer]:SWEep:FREQuency[:SENSor]:SRANge:STOP <Stop>**

Sets the stop frequency for the frequency power analysis with separate frequencies.

**Parameters:**

<Stop>            integer  
 Range:            0 to 1E12  
 \*RST:            10E6

**Example:**           SENS:SWE:FREQ:SENS2:SRAN:STAT ON  
 Activates use of a separate frequency range for frequency versus power measurement.  
 SENS:SWE:FREQ:SENS2:STAR 2.0GHZ  
 Sets a sweep start at 2 GHz irrespective of the current signal generator frequency settings.  
 SENS:SWE:FREQ:SENS2:STOP 2.9GHZ  
 Sets a sweep stop at 2.9 GHz irrespective of the current signal generator frequency settings.

**Manual operation:** See "[Max Frequency - Power Analysis](#)" on page 256

**:SENSe<ch>[:POWer]:SWEep:FREQuency[:SENSor]:SRANge[:STATe] <State>**

Activates the use of a frequency range for the power measurement that is different to the set signal generator frequency range. The separate frequency range is entered with commands [:SENSe<ch>\[:POWer\]:SWEep:FREQuency\[:SENSor\]:SRANge:STARt](#) on page 487 and [:SENSe<ch>\[:POWer\]:SWEep:FREQuency\[:SENSor\]:SRANge:STOP](#) on page 487.

**Parameters:**

<State>           0 | 1 | OFF | ON  
 \*RST:            0

**Example:**           SENS2:SWE:FREQ:SENS:SRAN ON  
 Activates use of a separate frequency range for frequency versus power measurement for sensor 2.  
 SENS2:SWE:FREQ:SENS:STAR 2.0GHZ  
 Sets a sweep start at 2 GHz irrespective of the current signal generator frequency settings.  
 SENS2:SWE:FREQ:SENS:STOP 2.9GHZ  
 Sets a sweep stop at 2.9 GHz irrespective of the current signal generator frequency settings.

**Manual operation:** See "[Use Separate Frequency- Power Analysis](#)" on page 255

**:SENSe<ch>[:POWer]:SWEep:POWer[:SENSor]:OFFSet <Offset>**

Defines the level offset at the sensor input in dB. Activate the offset with the command [:SENSe<ch>\[:POWer\]:SWEep:POWer\[:SENSor\]:OFFSet:STATe](#) on page 489.

**Parameters:**

<Offset>           float  
 Range:           -100 to 100  
 Increment:       0.01  
 \*RST:            0

**Example:**           SENS2:SWE:POW:OFFS -5dB  
 Defines a level offset of -5 dB.  
 SENS2:SWE:POW:OFFS:STAT ON  
 Activates that the specified level offset is considered.

**Options:**           Option R&S SMAB-K28

**Manual operation:** See " [Level Offset - Power Analysis](#) " on page 255

**:SENSe<ch>[:POWer]:SWEp:POWer[:SENSor]:OFFSet:STATe <State>**

Activates a level offset at the sensor input. Define the appropriate value with the command `:SENSe<ch>[:POWer]:SWEp:POWer[:SENSor]:OFFSet` on page 488.

**Parameters:**  
 <State>           0 | 1 | OFF | ON  
 \*RST:            0

**Example:**           SENS2:SWE:POW:OFFS:STAT ON  
 Activates the specified level offset.

**Options:**           Option R&S SMAB-K28

**:SENSe<ch>[:POWer]:SWEp:POWer[:SENSor]:SFRequency <SFRequency>**

Defines the separate frequency used for power vs. power measurement.

**Parameters:**  
 <SFRequency>   float  
 Range:           0 to 1E12  
 Increment:       1  
 \*RST:            1E6

**Example:**           SENS1:SWE:POW:SENS:SFR 2GHz  
 The measurement is performed at 2 GHz

**Manual operation:** See " [Use Separate Frequency- Power Analysis](#) " on page 255

**:SENSe<ch>[:POWer]:SWEp:POWer[:SENSor]:SFRequency:STATe <State>**

Activates the use of a different frequency for the power measurement.

**Parameters:**  
 <State>           0 | 1 | OFF | ON  
 \*RST:            0

**Example:**           SENS1:SWE:POW:SENS:SFR:STAT ON  
 Activates the use of a separate frequency than the generator frequency for power analysis

**Manual operation:** See " [Use Separate Frequency- Power Analysis](#) " on page 255

**:SENSe<ch>[:POWer]:SWEep:TIME[:SENSor]:OFFSet <Offset>**

Defines the level offset at the sensor input in dB. Activate the offset with the command `:SENSe<ch>[:POWer]:SWEep:TIME[:SENSor]:OFFSet:STATe` on page 490.

**Parameters:**

<Offset> float  
 Range: -100 to 100  
 Increment: 0.01  
 \*RST: 0

**Example:**

```
SENS2:SWE:TIME:OFFS -7dB
Defines a level offset of -7 dB.
SENS2:SWE:TIME:OFFS:STAT ON
The specified level offset is considered.
```

**Options:** Option R&S SMAB-K28

**Manual operation:** See "[Level Offset - Power Analysis](#)" on page 255

**:SENSe<ch>[:POWer]:SWEep:TIME[:SENSor]:OFFSet:STATe <State>**

Activates a level offset at the sensor input. Define the appropriate value with the command `:SENSe<ch>[:POWer]:SWEep:TIME[:SENSor]:OFFSet` on page 490.

**Parameters:**

<State> 0 | 1 | OFF | ON  
 \*RST: 0

**Example:**

```
SENS2:SWE:POW:TIME:STAT ON
Activates the specified level offset.
```

**Options:** Option R&S SMAB-K28

**Manual operation:** See "[Level Offset State- Power Analysis](#)" on page 255

**:SENSe<ch>[:POWer]:SWEep:TIME[:SENSor]:PULSe:STATe <State>**

Enables pulse data analysis. The measurement is started with command `INITiate`.

**Note:** The command is only available in time measurement mode and with R&S NRP-Z81 power sensors.

**Parameters:**

<State> 0 | 1 | OFF | ON  
 \*RST: 0

**Example:**

```
SENS1:SWE:TIM:PULS:STAT ON
Enables pulse data analysis.
```

**Options:** Option R&S SMAB-K28

**Manual operation:** See "[Pulse Analysis](#)" on page 260

---

```
:SENSe<ch>[:POWer]:SWEep:TIME[:SENSor]:PULSe:THReshold:BASE <Base>
```

Selects how the threshold parameters for pulse analysis are calculated.

**Note:** The command is only available in time measurement mode and with R&S NRPZ81 power sensors.

**Parameters:**

```
<Base>          VOLTage | POWer
*RST:          VOLTage
```

**Example:**

```
SENS1 :SWE:TIME:PULS:THR:BASE POW
Activates threshold calculation related to power.
```

**Options:** Option R&S SMAB-K28

**Manual operation:** See " [Base](#) " on page 260

---

```
:SENSe<ch>[:POWer]:SWEep:TIME[:SENSor]:PULSe:THReshold:POWER:
  HREFerence <HReference>
```

Sets the upper reference level in terms of percentage of the overall pulse level (power or voltage). The distal power defines the end of the rising edge and the start of the falling edge of the pulse.

**Note:** The command is only available in time measurement mode and with R&S NRPZ81 power sensors.

**Parameters:**

```
<HReference>   float
                Range:    0 to 100
                Increment: 0.01
                *RST:     90
```

**Options:** Option R&S SMAB-K28

**Manual operation:** See " [Distal](#) " on page 261

---

```
:SENSe<ch>[:POWer]:SWEep:TIME[:SENSor]:PULSe:THReshold:POWER:
  LREFerence <LReference>
```

Sets the lower reference level in terms of percentage of the overall pulse level. The proximal power defines the start of the rising edge and the end of the falling edge of the pulse.

**Note:** This parameter is only available in time measurement mode and R&S NRP-Z81 power sensors.

**Parameters:**

```
<LReference>   float
                Range:    0.0 to 100.0
                Increment: 0.01
                *RST:     10.0
```

**Example:**                `SENS:SWE:TIM:PULS:THR:LREF 10`  
Sets the lower reference level to 10%.

**Options:**                Option R&S SMAB-K28

**Manual operation:**    See " [Proximal](#) " on page 261

**:SENSe<ch>[:POWer]:SWEp:TIME[:SENSor]:PULSe:THReshold:POWer:  
REFerence <Reference>**

Sets the medial reference level in terms of percentage of the overall pulse level (power or voltage related). This level is used to define pulse width and pulse period.

**Note:** The command is only available in time measurement mode and with R&S NRPZ81 power sensors.

**Parameters:**

<Reference>                float  
Range:                    0.0 to 100.0  
Increment:                0.01  
\*RST:                     50.0

**Example:**                `SENS1:SWE:TIM:PULS:THR:REF 40`  
Sets the medial reference level to 40% of the overall pulse level.

**Options:**                Option R&S SMAB-K28

**Manual operation:**    See " [Mesial](#) " on page 261

**:SENSe<ch>[:POWer]:SWEp:TIME[:SENSor]:SFRequency <SFrequency>**

Defines the separate frequency used for power vs. time measurement.

**Parameters:**

<SFrequency>             float  
Range:                    0 to 1E12  
Increment:                1  
\*RST:                     1E6

**Example:**                `SENS1:SWE:TIME:SENS:SFR 2GHz`  
The measurement is performed at 2 GHz

**Manual operation:**    See " [Use Separate Frequency- Power Analysis](#) " on page 255

**:SENSe<ch>[:POWer]:SWEp:TIME[:SENSor]:SFRequency:STATe <State>**

Activates the use of a different frequency for the power measurement.

**Parameters:**

<State>                    0 | 1 | OFF | ON  
\*RST:                     0



**Example:** `SENS1:SWE:TIME:SENS:SFR:STAT ON`  
 Activates the use of a separate frequency than the generator frequency for power analysis

**Manual operation:** See " [Use Separate Frequency- Power Analysis](#) " on page 255

**:SENSe<ch>[:POWer]:SWEep:TIME[:SENSor]:TRIGger:AUTO <Auto>**

Sets the trigger level, the hysteresis and the dropout time to default values.

**Parameters:**

<Auto> ONCE  
 \*RST: ---

**Example:** `SENS1:SWE:TIME:SENS:TRIG:AUTO ONCE`  
 The trigger level is automatically determined

**Manual operation:** See " [Auto Set - Power Analysis](#) " on page 268

**:SENSe<ch>[:POWer]:SWEep:TIME[:SENSor]:TRIGger:DTIME <DTime>**

Determines the minimum time for which the signal must be below (above) the power level defined by level and hysteresis before triggering can occur again.

**Parameters:**

<DTime> float  
 Range: 0 to 10  
 \*RST: 200E-9

**Example:** `SENS1:SWE:TIME:SENS:TRIG:DTIM 10 us`  
 The drop out time is 10 us

**Manual operation:** See " [Drop out Time - Power Analysis](#) " on page 267

**:SENSe<ch>[:POWer]:SWEep:TIME[:SENSor]:TRIGger:HYSTeresis <Hysteresis>**

Sets the hysteresis of the internal trigger threshold. Hysteresis is the magnitude (in dB) the trigger signal level must drop below the trigger threshold (positive trigger slope) before triggering can occur again.

**Parameters:**

<Hysteresis> float  
 Range: 0 to 10  
 Increment: 0.001  
 \*RST: 0.5

**Example:** `SENS1:SWE:TIME:SENS:TRIG:HYST 0.5 dB`  
 The hysteresis is 0.5 dB

**Manual operation:** See " [Hysteresis - Power Analysis](#) " on page 267

---

```
:SENSe<ch>[:POWer]:SWEep:TIME[:SENSor]:TRIGger:LEVel <Level>
```

Sets the trigger threshold.

**Parameters:**

```
<Level>          float
                  Range:    -200 to 100
                  Increment: 0.001
                  *RST:     1
```

**Example:**            `SENS1:SWE:TIME:SENS:TRIG:LEV -20 dBm`  
Sets the trigger level to -20 dBm.

**Manual operation:** See "[Level - Power Analysis](#)" on page 267

---

```
:SENSe<ch>[:POWer]:SWEep:TIME[:SENSor]:TRIGger:SLOPe <TriggerSlope>
```

Sets the polarity of the active slope for the trigger signals.

**Parameters:**

```
<TriggerSlope>  POSitive | NEGative
                  *RST:    POSitive
```

**Example:**            `SENS1:SWE:TIME:TRIG:SLOP POS`  
The positive edge of a trigger signal is active.

**Options:**            Option R&S SMAB-K28

**Manual operation:** See "[Slope - Power Analysis](#)" on page 267

---

```
:SENSe<ch>[:POWer]:SWEep:TIME[:SENSor]:TRIGger:SOURce <Source>
```

Selects if the measurement is free running (FREE) or starts only after a trigger event. The trigger can be applied internally or externally.

**Parameters:**

```
<Source>        FREE | AUTO | INTernal | EXTernal
                  *RST:    AUTO
```

**Example:**            `SENS1:SWE:TIME:SENS:TRIG:SOUR FREE`  
The power versus time measurement is performed free running

**Manual operation:** See "[Mode - Power Analysis](#)" on page 266

---

```
:SENSe<ch>[:POWer]:ZERO
```

The command activates the autozero function. Zeroing is required in regular interval (at least once a day) and if the temperature has varied more than about 5 °C, if the sensor has been replaced or if measurements of signals with very low power are to be performed. The RF power source must be switched off or disconnected from the sensor before starting the autozero function.

**Example:**           SENS : ZERO  
                          activates autozero function.

**Usage:**            Event

#### **:SENSe[:POWer]:SWEep:ABORt**

Aborts the power analysis with NRP power sensors.

**Example:**           SENS : SWE : ABOR ; \*OPC?  
                          Aborts the current power measurement.

**Usage:**            Setting only

#### **:SENSe[:POWer]:SWEep:FREQUency:REFerence:DATA:COpy**

Generates a reference curve for "Frequency" measurement.

**Example:**           SENS : POW : SWE : FREQ : REF : DATA : COpy  
                          Generates a reference curve in frequency mode.

**Usage:**            Event

**Manual operation:** See "[Save To Ref](#)" on page 248

#### **:SENSe[:POWer]:SWEep:FREQUency:REFerence:DATA:POINt?**

Queries the number of points from the reference curve in "Frequency" measurement.

**Return values:**

<Points>            integer  
                          Range:     10 to 1000

**Example:**           SENS : POW : SWE : FREQ : REF : DATA : POIN?  
                          Queries the number of points from the reference curve in frequency mode.

**Usage:**            Query only

#### **:SENSe[:POWer]:SWEep:FREQUency:REFerence:DATA:XVALues <XValues>**

Sets or queries the x values of the two reference points, i.e. "Frequency X (Point A)" and "Frequency X (Point B)" in "Frequency" measurement.

**Parameters:**

<XValues>           string

**Example:**           SENSe : POW : SWE : FREQ : REF : DATA : XVAL 100MHZ , 22GHZ  
                          Sets the x value of reference "Point A" to 10 MHz, and the value of "Point B" to 10 GHz.

**Manual operation:** See "[Freq \(X\) / Pow \(Y\)](#)" on page 247

---

**:SENSe[:POWer]:SWEep:FREQUency:REFerence:DATA:YVALues <YValues>**

Sets or queries the y values of the two reference points, i.e. "Pow Y (Point A)" and "Power Y (Point B)" in "Frequency" measurement.

**Parameters:**

<YValues>                      string

**Example:**

SENSe:POW:SWE:FREQ:REF:DATA:YVAL -10,25  
Sets the y value of reference "Point A" to -10 dBm, and the value of "Point B" to -25 dBm.

**Manual operation:** See "[Freq \(X\) / Pow \(Y\)](#)" on page 247

---

**:SENSe[:POWer]:SWEep:FREQUency:RMODE <RMode>**

Selects single or continuous mode for measurement mode frequency in power analysis.

**Parameters:**

<RMode>                      SINGle | CONTInuous  
\*RST:                      CONTInuous

**Example:**

SENS:SWE:FREQ:RMODE SING  
Selects single measurement

**Manual operation:** See "[Execution - Power Analysis](#)" on page 253

---

**:SENSe[:POWer]:SWEep:FREQUency:SPACing[:MODE] <Mode>**

Selects the spacing for the frequency power analysis.

**Parameters:**

<Mode>                      LINear | LOGarithmic  
\*RST:                      LINear

**Example:**

SENS:SWE:FREQ:SPAC:MODE LIN  
Sets linear spacing of the sweep

**Manual operation:** See "[Spacing - Power Analysis](#)" on page 252

---

**:SENSe[:POWer]:SWEep:FREQUency:STARt <Start>**

Sets the start frequency for the frequency mode.

**Parameters:**

<Start>                      float  
Range:                      0 to 1E12  
\*RST:                      1E6

**Example:**

SENS:SWE:FREQ:STAR 2.0GHZ  
Sets a sweep start at 2 GHz.

**Manual operation:** See "[Min - Power Analysis](#)" on page 251

---

---

**:SENSe[:POWer]:SWEep:FREQuency:STEPs** <Steps>

Sets the number of measurement steps for the frequency mode.

**Parameters:**

<Steps>                    integer  
                                  Range:     10 to 1000  
                                  \*RST:     200

**Example:**                SENS:SWE:FREQ:STEP 500  
                                  Sets 500 steps

**Manual operation:**    See " [Steps - Power Analysis](#) " on page 252

---

**:SENSe[:POWer]:SWEep:FREQuency:STOP** <Stop>

Sets the stop frequency for the frequency mode.

**Parameters:**

<Stop>                     float  
                                  Range:     0 to 1E12  
                                  \*RST:     22GHZ

**Example:**                SENS:SWE:FREQ:STOP 20.0GHZ  
                                  Sets the sweep stop to 20 GHz

**Manual operation:**    See "[Max - Power Analysis](#)" on page 251

---

**:SENSe[:POWer]:SWEep:FREQuency:TIMing[:MODE]** <Mode>

Selects the mode in terms of speed and precision of the response of a measurement.

**Parameters:**

<Mode>                    FAST | NORMAl | HPRecision | FAST | NORMAl

**FAST**

Selection FAST leads to a fast measurement with a short integration time for each measurement step.

**NORMAl**

NORMAl leads to a longer but more precise measurement due to a higher integration time for each step.

\*RST:                    FAST

**Example:**                SENS:SWE:FREQ:TIM:MODE FAST  
                                  The fast measurement mode is selected.

**Manual operation:**    See " [Timing - Power Analysis](#) " on page 252

---

**:SENSe[:POWer]:SWEep:FREQuency:YSCale:AUTO <Auto>**

Activates autoscaling of the Y axis of the diagram.

**Parameters:**

<Auto>

OFF | CEXPanding | FEXPanding | CFLoating | FFLoating

**OFF**

Auto scaling is deactivated. If switching from activated to deactivated Auto scaling, the scaling is maintained.

**CEXPanding | FEXPanding**

Auto scale is activated. The scaling of the Y-axis is selected in such a way, that the trace is always visible. To this end, the range is expanded if the minimum or maximum values of the trace move outside the current scale. The step width is 5 dB for selection course and variable in the range of 0.2 db to 5 dB for selection fine.

**CFLoating | FFLoating**

Auto scale is activated. The scaling of the Y-axis is selected in such a way, that the trace is always visible. To this end, the range is either expanded if the minimum or maximum values of the trace move outside the current scale or scaled down if the trace fits into a reduced scale. The step width is 5 dB for selection course and variable in the range of 0.2 db to 5 dB for selection fine.

\*RST: CEXPanding

**Example:**

SENS:SWE:FREQ:YSC:AUTO OFF

Deactivates auto scale

**Manual operation:** See "[Auto Scale - Power Analysis](#)" on page 258

---

**:SENSe[:POWer]:SWEep:FREQuency:YSCale:AUTO:RESet**

Resets the Y scale to suitable values after the use of auto scaling in the expanding mode. For this mode, the scale might get expanded because of temporarily high-power values. The reset function resets the diagram in such a way that it matches smaller power values again.

**Example:**

SENS:SWE:FREQ:YSC:AUTO:RES

Resets auto scale

**Usage:**

Event

**Manual operation:** See "[Reset Auto Scale - Power Analysis](#)" on page 258

---

**:SENSe[:POWer]:SWEep:FREQuency:YSCale:MAXimum <Maximum>**

Sets the maximum value for the y axis of the measurement diagram.

**Parameters:**

<Maximum> float  
 Range: -200 to 100  
 Increment: 0.01  
 \*RST: 40

**Example:**

SENS:SWE:FREQ:YSC:MAX 10DBM  
 Sets 10 dBm as the upper limit of the measurement diagram.

**Manual operation:** See " [Min - Max Level - Power Analysis](#) " on page 257

**:SENSe[:POWer]:SWEep:FREQuency:YSCale:MINimum** <Minimum>

Sets the minimum value for the y axis of the measurement diagram.

**Parameters:**

<Minimum> float  
 Range: -200 to 100  
 Increment: 0.01  
 \*RST: -40

**Example:**

SENS:SWE:FREQ:YSC:MIN -10DB  
 Sets -10 dBm as the lower limit of the measurement diagram.

**Manual operation:** See " [Min - Max Level - Power Analysis](#) " on page 257

**:SENSe[:POWer]:SWEep:HCOPY:DATA?**

Queries the measurement data directly. The data is transferred to the remote client as data stream.

Readable ASCII data is available for hardcopy language CSV. The representation of the values depends on the selected orientation for the CSV format.

**Return values:**

<Data> block data

**Example:**

```
SENS:SWE:HCOP:DEV:LANG CSV
```

selects output format \*.csv.

```
SENS:SWE:HCOP:DEV:LANG:CSV:ORI HOR
```

selects horizontal orientation

```
SENS:SWE:HCOP:DEV:LANG:CSV:SEP SEM
```

selects ";" as the separator between the values

```
SENS:SWE:HCOP:DEV:LANG:CSV:DPO DOT
```

selects "." as decimal point

```
SENS:SWE:HCOP:DATA?
```

queries the measurement data of the current traces

Response:

```
#2651009500000;1019000000;1028500000;1038000000
```

```
-9.5;-9.7;-6.3;-2.5
```

The hash symbol # introduces the data block. The next number indicates how many of the following digits describe the length of the data block. In the example, the 2 following digit indicates the length to be 65 characters.

Because horizontal representation is selected, a row with all the x-values of the active trace (frequency) follows. The second row contains all the y-values of the active trace (power). The rows end with a new line (each counts as one character).

**Note:** if more than one trace is active, the third row contains the x values of the second active trace, and so on.

**Example:**

```
SENS:SWE:HCOP:DEV:LANG:CSV:ORI VERT
```

selects horizontal orientation

```
SENS:SWE:HCOP:DATA?
```

queries the measurement data of the current traces

Response:

```
#2681009500000;-9.5; 1019000000;-9.7; 1028500000;-6.3;
```

```
1038000000;-2.5;
```

for vertical representation the length of the data block is 68 the first power value, the second row contains the second frequency value of the active trace followed by the second power value, and so on. The rows end with a new line (each counts as one character).

**Note:** if more than one trace is active, the first row also contains the value pairs of the second active trace, and so on.

**Usage:**

Query only

---

```
:SENSe[:POWer]:SWEp:HCOPy:DEvice <Device>
```

Defines the output device. The setting is fixed to FILE, i.e. the hardcopy is stored in a file.

**Parameters:**

<Device>

FILE | PRINter

\*RST: FILE



**Example:**           SENS:SWE:HCOP:DEV FIL  
Selects output device file.

**:SENSe[:POWer]:SWEep:HCOPy:DEVIce:LANGUage <Language>**

Selects the bitmap graphic format for the screenshot of the power analysis trace.

In addition, ASCII file format \*.csv is offered. If file format \*.csv is selected, the trace data is saved as an ASCII file with comma separated values. It is also possible to directly retrieve the data using command :SENSe[:POWer]:SWEep:HCOPy:DATA? on page 499

**Parameters:**  
<Language>           BMP | JPG | XPM | PNG | CSV

\*RST:           BMP

**Example:**           SENS:SWE:HCOP:DEV:LANG BMP  
Selects output format \*.bmp.

**Manual operation:** See "Format - Power Analysis" on page 275

**:SENSe[:POWer]:SWEep:HCOPy:DEVIce:LANGUage:CSV:DPOint <DPoint>**

Defines which character is used as the decimal point of the values, either dot or comma.

**Parameters:**  
<DPoint>           DOT | COMMa

\*RST:           DOT

**Example:**           SENS:SWE:HCOP:DEV:LANG CSV  
Selects output format \*.csv.  
SENS:SWE:HCOP:DEV:LANG:CSV:DPO DOT  
Selects character dot for being used as decimal point.

**Manual operation:** See "Decimal Point" on page 279

**:SENSe[:POWer]:SWEep:HCOPy:DEVIce:LANGUage:CSV:HEADer <Header>**

Defines whether each row (or column depending on the orientation) should be preceded by a header containing information about the trace (see also :SENSe[:POWer]:SWEep:HCOPy:DATA? on page 499).

**Parameters:**  
<Header>           OFF | STANdard

\*RST:           OFF

**Example:**           SENS:SWE:HCOP:DEV:LANG CSV  
Selects output format \*.csv.  
SENS:SWE:HCOP:DEV:LANG:CSV:HEAD STAN  
Selects the standard header for the \*.csv file.

**Manual operation:** See ["Row Header"](#) on page 279

---

**:SENSe[:POWer]:SWEep:HCOPy:DEVIce:LANGUage:CSV:ORientation**  
<Orientation>

Defines the orientation of the X/Y value pairs.

**Parameters:**

<Orientation>           HORizontal | VERTical  
\*RST:                 VERTical

**Example:**

SENS:SWE:HCOP:DEV:LANG CSV

Selects output format \*.csv.

SENS:SWE:HCOP:DEV:LANG:CSV:ORI VERT

Selects vertical orientation, the value pairs are written in a column like structure (separated by the selected separator, e.g. tab)

**Manual operation:** See ["Orientation"](#) on page 278

---

**:SENSe[:POWer]:SWEep:HCOPy:DEVIce:LANGUage:CSV[:COLumn]:SEParator**  
<Separator>

Defines which character is to separate the values, either tabulator, semicolon, comma or blank.

**Parameters:**

<Separator>           TABulator | SEMicolon | COMMa | BLANK  
\*RST:                 COMMa

**Example:**

SENS:SWE:HCOP:DEV:LANG CSV

Selects output format \*.csv.

SENS:SWE:HCOP:DEV:LANG:CSV:SEP TAB

A tab separates the values.

**Manual operation:** See ["Separator"](#) on page 279

---

**:SENSe[:POWer]:SWEep:HCOPy:DEVIce:SIZE** <Size>

Sets the size of the hardcopy in number of pixels. The first value of the size setting defines the width, the second value the height of the image.

**Parameters:**

<Size>                 320,240 | 640,480 | 800,600 | 1024,768  
\*RST:                 320,240

**Example:**

SENS:SWE:HCOP:DEV:LANG BMP

Selects output format \*.bmp.

SENS:SWE:HCOP:DEV:SIZE 320,240

The size of the bitmap is 320 pixels by 240 pixels.

**:SENSe[:POWer]:SWEep:HCOPy:FILE[:NAME] <Name>**

Creates or selects a file for storing the hardcopy after the `:SENSe[:POWer]:SWEep:HCOPy[:EXECute]` on page 507 command is sent. The directory is either defined with the command `MMEMory:CDIR` or the path is specified together with the file name. Access to the file via remote control is possible using the commands of the MMEM-Subsystem. In contrast, command `:SENSe[:POWer]:SWEep:HCOPy:DATA?` on page 499 transfers the hardcopy contents directly to the remote client where they can be further processed.

**Parameters:**

<Name>                    string

**Example:**

```
SENS:SWE:HCOP:DEV:LANG BMP
```

Selects output format \*, bmp.

```
SENS:SWE:HCOP:FILE:AUTO:STAT OFF
```

Switches off automatic naming.

```
SENS:SWE:HCOP:FILE 'var/trace/nrp_trace1'
```

creates the file `nrp_trace1.bmp` in the trace directory.

```
SENS:SWE:HCOP:EXEC
```

Triggers the generation of a hardcopy of the current trace. The hardcopy is stored in the file `nrp_trace1.bmp`.

**Manual operation:** See "[File name - Power Analysis](#)" on page 274

**:SENSe[:POWer]:SWEep:HCOPy:FILE[:NAME]:AUTO:DIRectory <Directory>**

Defines the directory into which the hardcopy files are stored if auto naming is activated (`SENS:SWE:HCOP:FILE:AUTO:STAT ON`).

**Parameters:**

<Directory>                string

**Example:**

```
SENS:SWE:HCOP:FILE:AUTO:DIR 'var/nrp'
```

Hardcopy file are stored in directory `var/nrp` if automatic naming is activated.

**Manual operation:** See "[Path](#)" on page 276

**:SENSe[:POWer]:SWEep:HCOPy:FILE[:NAME]:AUTO:DIRectory:CLEar**

Deletes all files with extensions `bmp`, `img`, `png`, `xpm` and `csv` in the directory set for automatic naming.

**Example:**

```
SENS:SWE:HCOP:FILE:AUTO:DIR 'var/nrp'
```

Hardcopy file are stored in directory `var/nrp` if automatic naming is activated.

```
SENS:SWE:HCOP:FILE:AUTO:DIR:CLE
```

Deletes all hardcopy file that are stored in the directory `var/nrp`.

**Usage:**                    Event

**Manual operation:** See ["Clear Parth"](#) on page 276

---

**:SENSe[:POWer]:SWEep:HCOPy:FILE[:NAME]:AUTO:FILE?**

Queries the file name generated with the automatic naming settings.

**Note:** As default the automatically generated file name is composed of: >PAth>/<Prefix><YYYY><MM><DD><Number>.<Format>. Each component can be deactivated/ activated separately to individually design the file name.

**Return values:**

<File>                      string

**Example:**

SENS:SWE:HCOP:DEV:LANG BMP

Selects output format \* .bmp.

SENS:SWE:HCOP:FILE:AUTO:DIR 'var/nrp'

Hardcopy files are stored in directory var/nrp if automatic naming is activated.

SENS:SWE:HCOP:FILE:AUTO:PREF 'sens1'

The file name starts with the prefix sens1. The usage of automatic naming with prefix and date in the file name is preset (...:STAT ON).

SENS:SWE:HCOP

Triggers the generation of a hardcopy of the current trace.

SENS:SWE:HCOP:FILE:AUTO:FILE?

Queries the file name

**Usage:**                      Query only

**Manual operation:** See [" File name - Power Analysis "](#) on page 274

---

**:SENSe[:POWer]:SWEep:HCOPy:FILE[:NAME]:AUTO:STATe <State>**

Activates/deactivates automatic naming of the hardcopy files.

**Parameters:**

<State>                      0 | 1 | OFF | ON

\*RST:                      1

**Example:**

SENS:SWE:HCOP:FILE:AUTO:STAT OFF

Deactivates automatic naming of the hardcopy files. The file name and directory is now defined with command.

SENS:SWE:HCOP:FILE:NAME <psth>

**Manual operation:** See [" File name - Power Analysis "](#) on page 274

---

**:SENSe[:POWer]:SWEep:HCOPy:FILE[:NAME]:AUTO[:FILE]:DAY?**

Queries the day of the date part in the automatic file name.

**Return values:**

<Day> integer  
 Range: 1 to 31  
 \*RST: 1

**Example:**

SENS:SWE:HCOPY:FILE:AUTO:DAY?  
 Queries the day of the date part in the automatic file name.

**Usage:**

Query only

**Manual operation:** See "[Prefix, Year, Month, Day, Instrument Name](#)" on page 277

**:SENSe[:POWer]:SWEep:HCOPY:FILE[:NAME]:AUTO[:FILE]:DAY:STATe** <State>

Activates the usage of the day in the automatic file name.

**Parameters:**

<State> 0 | 1 | OFF | ON  
 \*RST: 1

**Example:**

SENS:SWE:HCOPY:FILE:AUTO:DAY:STAT OFF  
 Deactivates the usage of the day in the automatic file name.

**Manual operation:** See "[Prefix, Year, Month, Day, Instrument Name](#)" on page 277

**:SENSe[:POWer]:SWEep:HCOPY:FILE[:NAME]:AUTO[:FILE]:MONTH?**

Queries the day of the date part in the automatic file name.

**Return values:**

<Month> integer  
 Range: 1 to 12  
 \*RST: 1

**Example:**

SENS:SWE:HCOPY:FILE:AUTO:MONT?  
 Queries the month of the date part in the automatic file name.

**Usage:**

Query only

**Manual operation:** See "[Prefix, Year, Month, Day, Instrument Name](#)" on page 277

**:SENSe[:POWer]:SWEep:HCOPY:FILE[:NAME]:AUTO[:FILE]:MONTH:STATe**  
 <State>

Activates the usage of the month in the automatic file name.

**Parameters:**

<State> 0 | 1 | OFF | ON  
 \*RST: 1

**Example:**

SENS:SWE:HCOPY:FILE:AUTO:MONT:STAT OFF  
 Deactivates the usage of the month in the automatic file name.

**Manual operation:** See "[Prefix, Year, Month, Day, Instrument Name](#)" on page 277

---

**:SENSe[:POWer]:SWEep:HCOPy:FILE[:NAME]:AUTO[:FILE]:NUMBer?**

Queries the generated number in the automatic file name.

**Return values:**

<Number>	integer
Range:	0 to 999999
*RST:	0

**Example:**           SENS : SWE : HCOP : FILE : AUTO : NUMB?  
Queries the number in the automatic file name.

**Usage:**            Query only

**Manual operation:** See "[Current Auto Number](#)" on page 277

---

**:SENSe[:POWer]:SWEep:HCOPy:FILE[:NAME]:AUTO[:FILE]:PREFix <Prefix>**

Sets the prefix part in the automatic file name.

**Parameters:**

<Prefix>	string
----------	--------

**Example:**           SENS : SWE : HCOP : FILE : AUTO : PREF 'sensor'  
The prefix sensor is used in the automatically generated file name of the hardcopy file.

**Manual operation:** See "[Prefix, Year, Month, Day, Instrument Name](#)" on page 277

---

**:SENSe[:POWer]:SWEep:HCOPy:FILE[:NAME]:AUTO[:FILE]:PREFix:STATe <State>**

Activates the usage of the prefix in the automatic file name.

**Parameters:**

<State>	0   1   OFF   ON
*RST:	1

**Example:**           SENS : SWE : HCOP : FILE : AUTO : PREF : STAT OFF  
Deactivates the usage of the prefix in the automatic file name.

**Manual operation:** See "[Prefix, Year, Month, Day, Instrument Name](#)" on page 277

---

**:SENSe[:POWer]:SWEep:HCOPy:FILE[:NAME]:AUTO[:FILE]:YEAR?**

Queries the year of the date part in the automatic file name.

**Return values:**

<Year>	integer
Range:	1784 to 8000
*RST:	0

**Example:**           SENS : SWE : HCOP : FILE : AUTO : YEAR?  
Queries the year of the date part in the automatic file name.

**Usage:** Query only

**Manual operation:** See "[Prefix, Year, Month, Day, Instrument Name](#)" on page 277

**:SENSe[:POWer]:SWEep:HCOPy:FILE[:NAME]:AUTO[:FILE]:YEAR:STATe <State>**

Activates the usage of the year in the automatic file name.

**Parameters:**

<State> 0 | 1 | OFF | ON  
\*RST: 1

**Example:** SENS:SWE:HCOP:FILE:AUTO:YEAR:STAT OFF  
Deactivates the usage of the year in the automatic file name.

**Manual operation:** See "[Prefix, Year, Month, Day, Instrument Name](#)" on page 277

**:SENSe[:POWer]:SWEep:HCOPy[:EXECute]**

Triggers the generation of a hardcopy of the current measurement diagram. The data is written into the file selected/created with the [:SENSe\[:POWer\]:SWEep:HCOPy:FILE\[:NAME\]](#) on page 503 command.

**Example:** SENS:SWE:HCOP:DEV:LANG BMP  
Selects output format \*.bmp.  
SENS:SWE:HCOP:FILE:AUTO:STAT OFF  
Switches off automatic file naming.  
SENS:SWE:HCOP:FILE 'var/nrp\_trace1'  
Creates the file nrp\_trace1.bmp in the set path.  
SENS:SWE:HCOP  
Triggers the generation of a hardcopy of the current measurement diagram. The hardcopy is stored in the file nrp\_trace1.bmp.

**Usage:** Event

**Manual operation:** See "[File name - Power Analysis](#)" on page 274

**:SENSe[:POWer]:SWEep:INITiate**

Starts the power analysis with NRP power sensor.

**Example:** SENS:SWE:INIT  
Start the power measurement.

**Usage:** Setting only

**:SENSe[:POWer]:SWEep:MODE <Mode>**

Selects power versus frequency measurement (frequency response), power vs power measurement (power sweep, AM/AM) or power vs. time measurement.

**Parameters:**

<Mode>                    FREQuency | POWer | TIME  
 \*RST:                    FREQuency

**Example:**

SENS : SWE : MODE FREQ  
 Selects frequency mode.

**Manual operation:** See "[Mode - Power Analysis](#)" on page 251

**:SENSe[:POWER]:SWEep:POWER:REFerence:DATA:COPI**

Generates a reference curve for "Power" measurement.

**Example:**

SENS : POW : SWE : POW : REF : DATA : COPY  
 Generates a reference curve in power mode.

**Usage:**

Event

**Manual operation:** See "[Save To Ref](#)" on page 248

**:SENSe[:POWER]:SWEep:POWER:REFerence:DATA:POINts?**

Queries the number of points from the reference curve in "Power" measurement.

**Return values:**

<Points>                    integer  
 Range:                    10 to 1000

**Example:**

SENS : POW : SWE : POW : REF : DATA : POIN?  
 Queries the number of points from the reference curve in power mode.

**Usage:**

Query only

**:SENSe[:POWER]:SWEep:POWER:REFerence:DATA:XVALues <XValues>**

Sets or queries the x values of the two reference points, i.e. "Power X (Point A)" and "Power X (Point B)" in "Power" measurement.

**Parameters:**

<XValues>                    string

**Example:**

SENSe : POW : SWE : POW : REF : DATA : XVAL -15DBM, 20DBM  
 Sets the x value of reference "Point A" to -15 dBm, and the value of "Point B" to 20 dBm.

**Manual operation:** See "[Pow \(X\) / Pow \(Y\)](#)" on page 248

**:SENSe[:POWER]:SWEep:POWER:REFerence:DATA:YVALues <YValues>**

Sets or queries the y values of the two reference points, i.e. "Power Y (Point A)" and "Power Y (Point B)" in "Power" measurement.



**Parameters:**

<YValues> string

**Example:**

SENSe:POW:SWE:TIME:REF:DATA:YVAL -30,10  
Sets the y value of reference "Point A" to -30 dBm, and the value of "Point B" to 10 dBm.

**Manual operation:** See "[Pow \(X\) / Pow \(Y\)](#)" on page 248

**:SENSe[:POWer]:SWEep:POWer:RMODE** <RMode>

Selects single or continuous mode for measurement mode power in power analysis.

**Parameters:**

<RMode> SINGLE | CONTInuous  
\*RST: CONTInuous

**Example:**

SENS:SWE:POW:RMODE SING  
Selects single measurement.

**Manual operation:** See "[Execution - Power Analysis](#)" on page 253

**:SENSe[:POWer]:SWEep:POWer:SPACing[:MODE]** <Mode>

Selects the spacing for the frequency power analysis.

**Parameters:**

<Mode> LINear  
\*RST: LINear

**Example:**

SENS:SWE:FREQ:SPAC:MODE LIN  
Sets linear spacing of the sweep.

**Manual operation:** See "[Spacing - Power Analysis](#)" on page 252

**:SENSe[:POWer]:SWEep:POWer:STARt** <Start>

Sets the start level for the power versus power measurement.

**Parameters:**

<Start> float  
Range: -145 to 20  
Increment: 0.01  
\*RST: 1MHZ

**Example:**

SENS:SWE:POW:STAR -20DBM  
Sets the start level to -20 dBm

**Manual operation:** See "[Min - Power Analysis](#)" on page 251

**:SENSe[:POWer]:SWEep:POWer:STEPs** <Steps>

Sets the number of measurement steps for the power versus power measurement.

**Parameters:**

<Steps> integer  
 Range: 10 to 1000  
 \*RST: 500

**Example:**

SENS:SWE:POW:STEP 500  
 Sets the 500 measurement steps.

**Manual operation:** See "[Steps - Power Analysis](#)" on page 252

**:SENSe[:POWer]:SWEep:POWer:STOP <Stop>**

Sets the stop level for the power versus power measurement.

**Parameters:**

<Stop> float  
 Range: -145 to 20  
 Increment: 0.01  
 \*RST: 40

**Example:**

SENS:SWE:POW:STOP 20.0DBM  
 Sets the stop level to 20 dBm.

**:SENSe[:POWer]:SWEep:POWer:TIMing[:MODE] <Mode>**

Selects the timing mode of the measurement.

**Parameters:**

<Mode> FAST | NORMal | HPRecision | FAST | NORMal

**FAST**

Selection FAST leads to a fast measurement with a short integration times for each measurement step.

**NORMal**

NORMal leads to a longer but more precise measurement due to a higher integration time for each step.

\*RST: NORMal

**Example:**

SENS:SWE:POW:TIM:MODE FAST  
 Selects fast mode.

**Manual operation:** See "[Timing - Power Analysis](#)" on page 252

**:SENSe[:POWer]:SWEep:POWer:YSCale:AUTO <Auto>**

Activates autoscaling of the Y axis of the diagram.

**Parameters:**

<Auto> OFF | CEXPanding | FEXPanding | CFLoating | FFLoating

**OFF**

Auto scaling is deactivated. When switching from activated to deactivated Auto scaling, the scaling is maintained. When switching from deactivated to activated Auto scaling, the scaling is reset to min = max = 0.

**CEXPanding | FEXPanding**

Auto scale is activated. The scaling of the Y-axis is selected in such a way, that the trace is always visible. To this end, the range is expanded if the minimum or maximum values of the trace move outside the current scale. The step width is 5 dB for selection course and variable in the range of 0.2 db to 5 dB for selection fine.

**CFloating | FFloating**

Auto scale is activated. The scaling of the Y-axis is selected in such a way, that the trace is always visible. To this end, the range is either expanded if the minimum or maximum values of the trace move outside the current scale or scaled down if the trace fits into a reduced scale. The step width is 5 dB for selection course and variable in the range of 0.2 db to 5 dB for selection fine.

\*RST: CEXPanding

**Example:**

```
SENS:SWE:POW:YSC:AUTO OFF
Deactivates auto scale.
```

**Manual operation:** See "[Auto Scale - Power Analysis](#)" on page 258

**:SENSe[:POWer]:SWEep:POWer:YSCale:AUTO:RESet**

Resets the Y scale to suitable values after the use of auto scaling in the expanding mode. For this mode, the scale might get expanded because of temporarily high power values. The reset function allows resetting the diagram to match smaller power values again.

**Example:**

```
SENS:SWE:POW:YSC:AUTO:RES
Resets auto scale.
```

**Usage:**

Event

**Manual operation:** See "[Reset Auto Scale - Power Analysis](#)" on page 258

**:SENSe[:POWer]:SWEep:POWer:YSCale:MAXimum <Maximum>**

Sets the maximum value for the y axis of the measurement diagram.

**Parameters:**

<Maximum>

float

Range: -200 to 100

Increment: 0.01

\*RST: 30

**Example:** `SENS:SWE:POW:YSC:MAX 10DBM`  
Sets 10 dBm as the upper limit of the measurement diagram.

**Manual operation:** See "[Min - Max Level - Power Analysis](#)" on page 257

**:SENSe[:POWer]:SWEep:POWer:YSCale:MINimum <Minimum>**

Sets the minimum value for the y axis of the measurement diagram.

**Parameters:**

<Minimum> float  
Range: -200 to 100  
Increment: 0.01  
\*RST: -40

**Example:** `SENS:SWE:POW:YSC:MIN -10DBM`  
Sets -10 dBm as the lower limit of the measurement diagram.

**Manual operation:** See "[Min - Max Level - Power Analysis](#)" on page 257

**:SENSe[:POWer]:SWEep:RMODE <RMode>**

Selects single or continuous mode for power analysis (all measurement modes).

**Parameters:**

<RMode> SINGLE | CONTInuous  
\*RST: SINGLE

**Example:** `SENS:SWE:RMODE SING`  
Selects single measurement.

**Manual operation:** See "[Execution - Power Analysis](#)" on page 253

**:SENSe[:POWer]:SWEep:TIME:AVERAge[:COUNT] <Count>**

Selects the averaging factor in time mode. The count number determines how many measurement cycles are used to form a measurement result. Higher averaging counts reduce noise but increase the measurement time. Averaging requires a stable trigger event so that the measurement cycles have the same timing.

**Parameters:**

<Count> 1 | 2 | 4 | 8 | 16 | 32 | 64 | 128 | 256 | 512 | 1024  
\*RST: 1

**Example:** `SENS:SWE:MODE TIME`  
Selects time mode.  
`SENS:SWE:TIME:AVER 128`  
Selects averaging factor 128.

**Options:** Option R&S SMAB-K28

**Manual operation:** See "[Average - Power Analysis](#)" on page 252

---

**:SENSe[:POWer]:SWEep:TIME:REFerence:DATA:COpy**

Generates a reference curve for "Time" measurement.

**Example:**                    `SENS:POW:SWE:TIME:REF:DATA:COpy`  
Generates a reference curve in time mode.

**Usage:**                    Event

**Manual operation:**    See ["Save To Ref"](#) on page 248

---

**:SENSe[:POWer]:SWEep:TIME:REFerence:DATA:POINts?**

Queries the number of points from the reference curve in "Time" measurement.

**Return values:**

<Points>                    integer  
Range:                    10 to 1000  
\*RST:                    0

**Example:**                    `SENS:POW:SWE:TIME:REF:DATA:POIN?`  
Queries the number of points from the reference curve in time mode.

**Usage:**                    Query only

---

**:SENSe[:POWer]:SWEep:TIME:REFerence:DATA:XVALues <XValues>**

Sets or queries the x values of the two reference points, i.e. "Time X (Point A)" and "Time X (Point B)" in "Time" measurement.

**Parameters:**

<XValues>                    string

**Example:**                    `SENSe:POW:SWE:TIME:REF:DATA:XVAL 5,45`  
Sets the x value of reference "Point A" to 5  $\mu$ s, and the value of "Point B" to 45  $\mu$ s.

**Manual operation:**    See ["Time \(X\) / Pow \(Y\)"](#) on page 248

---

**:SENSe[:POWer]:SWEep:TIME:REFerence:DATA:YVALues <YValues>**

Sets or queries the y values of the two reference points, i.e. "Power Y (Point A)" and "Power Y (Point B)" in "Time" measurement.

**Parameters:**

<YValues>                    string

**Example:**                    `SENSe:POW:SWE:TIME:REF:DATA:YVAL -30,10`  
sets the y value of reference "Point A" to -30 dBm, and the value of "Point B" to 10 dBm.

**Manual operation:**    See ["Time \(X\) / Pow \(Y\)"](#) on page 248

---

**:SENSe[:POWer]:SWEep:TIME:RMODe** <RMode>

Selects single or continuous mode for measurement mode time in power analysis.

**Parameters:**

<RMode>                SINGle | CONTInuous  
 \*RST:                CONTInuous

**Example:**                SENS:SWE:TIME:RMOD SING  
 Selects single measurement.

**Manual operation:**    See "[Execution - Power Analysis](#)" on page 253

---

**:SENSe[:POWer]:SWEep:TIME:SPACing[:MODE]** <Mode>

Queries the sweep spacing for the power versus time measurement. The spacing is fixed to linear.

**Parameters:**

<Mode>                LINear  
 \*RST:                LINear

**Example:**                SENS:SWE:TIME:SPAC?  
 Queries the sweep spacing.

**Manual operation:**    See "[Spacing - Power Analysis](#)" on page 252

---

**:SENSe[:POWer]:SWEep:TIME:STARt** <Start>

Sets the start time for the power versus time measurement. Value 0 defines the trigger point. By choosing a negative time value, the trace can be shifted in the diagram. It is possible, that the measurement cannot be performed over the complete time range because of limitations due to sensor settings. In this case, an error message is output.

**Parameters:**

<Start>                float  
 Range:                -1 to 1  
 Increment:            1E-12  
 \*RST:                -5E-6

**Example:**                SENS:SWE:TIME:STAR 0s  
 Sets the start time to 0 s.

**Manual operation:**    See "[Min - Power Analysis](#)" on page 251

---

**:SENSe[:POWer]:SWEep:TIME:STEPs** <Steps>

Sets the number of measurement steps for the power versus time measurement. Value 0 defines the trigger point.

**Parameters:**

<Steps> integer  
 Range: 10 to 1000  
 \*RST: 500

**Example:**

SENS:SWE:TIME:STEP 500  
 Sets the 500 measurement steps.

**Manual operation:** See "[Steps - Power Analysis](#)" on page 252

**:SENSe[:POWer]:SWEep:TIME:STOP <Stop>**

Sets the stop time for the power versus time measurement.

**Parameters:**

<Stop> float  
 Range: 0 to 2  
 Increment: 1E-12  
 \*RST: 1E-3

**Example:**

SENS:SWE:TIME:STOP 1ms  
 Sets the stop time to 1 ms.

**Manual operation:** See "[Max - Power Analysis](#)" on page 251

**:SENSe[:POWer]:SWEep:TIME:TEVents <TriggerTEvents>**

Determines, whether the measurement data processing starts with a trigger event in one of the sensors (Logical OR), or whether all channels have to be triggered (logical AND). Each sensor evaluates a trigger event according to its setting independently. This function supports the internal or external trigger modes with multi-channel time measurements.

**Parameters:**

<TriggerTEvents> AND | OR  
 \*RST: AND

**Example:**

SENS:POW:SWE:TIME:TEV AND  
 The measurement data processing starts when all channels are triggered.

**Options:** Option R&S SMAB-K28

**Manual operation:** See "[All Trigger Events - Power Analysis](#)" on page 253

**:SENSe[:POWer]:SWEep:TIME:YScale:AUTO <Auto>**

Activates autoscaling of the Y axis in the diagram.

**Parameters:**

<Auto> OFF | CEXPanding | FEXPanding | CFLoating | FFLoating

**OFF**

Auto scaling is deactivated. When switching from activated to deactivated Auto scaling, the scaling is maintained. When switching from deactivated to activated Auto scaling, the scaling is reset to min = max = 0.

**CEXPanding | FEXPanding**

Auto scale is activated. The scaling of the Y-axis is selected in such a way, that the trace is always visible. To this end, the range is expanded if the minimum or maximum values of the trace move outside the current scale. The step width is 5 dB for selection course and variable in the range of 0.2 db to 5 dB for selection fine.

**CFloating | FFloating**

Auto scale is activated. The scaling of the Y-axis is selected in such a way, that the trace is always visible. To this end, the range is either expanded if the minimum or maximum values of the trace move outside the current scale or scaled down if the trace fits into a reduced scale. The step width is 5 dB for selection course and variable in the range of 0.2 db to 5 dB for selection fine.

\*RST: CEXPanding

**Example:**

```
SENS:SWE:TIME:YSC:AUTO OFF
Deactivates auto scale
```

**Manual operation:** See "[Auto Scale - Power Analysis](#)" on page 258

**:SENSe[:POWer]:SWEp:TIME:YSCale:AUTO:RESet**

Resets the Y scale to suitable values after the use of auto scaling in the expanding mode. For this mode, the scale might get expanded because of temporarily high power values. The reset function allows resetting the diagram to match smaller power values again.

**Example:**

```
SENS:SWE:TIME:YSC:AUTO:RES
Resets auto scale.
```

**Usage:**

Event

**Manual operation:** See "[Reset Auto Scale - Power Analysis](#)" on page 258

**:SENSe[:POWer]:SWEp:TIME:YSCale:MAXimum <Maximum>**

Sets the maximum value for the y axis of the measurement diagram.

**Parameters:**

<Maximum>

float

Range: -200 to 100

Increment: 0.01

\*RST: 30.0

Default unit: dBm



**Example:**                   SENS : SWE : TIME : YSC : MAX 10DBM  
Sets 10 dBm as the upper limit of the measurement diagram.

**Manual operation:** See " [Min - Max Level - Power Analysis](#) " on page 257

**:SENSe[:POWER]:SWEep:TIME:YSCale:MINimum <Minimum>**

Sets the minimum value for the y axis of the measurement diagram.

**Parameters:**

<Minimum>                   float  
Range:                   -200 to 100  
Increment:               0.01  
\*RST:                   dBm

**Example:**                   SENS : SWE : TIME : YSC : MIN -10DBM  
Sets -10 dBm as the lower limit of the measurement diagram.

**Manual operation:** See " [Min - Max Level - Power Analysis](#) " on page 257

## 14.14.5 TRACe Subsystem

:TRACe<ch>[:POWER]:SWEep:COLor.....	518
:TRACe<ch>[:POWER]:SWEep:COPY.....	519
:TRACe<ch>[:POWER]:SWEep:DATA:POINTs?.....	519
:TRACe<ch>[:POWER]:SWEep:DATA:XVALues?.....	519
:TRACe<ch>[:POWER]:SWEep:DATA:YSValue?.....	520
:TRACe<ch>[:POWER]:SWEep:DATA:YVALues?.....	520
:TRACe<ch>[:POWER]:SWEep:FEED.....	520
:TRACe<ch>[:POWER]:SWEep:MEASurement:POWER:AVERAge?.....	521
:TRACe<ch>[:POWER]:SWEep:MEASurement:POWER:HREFerence?.....	521
:TRACe<ch>[:POWER]:SWEep:MEASurement:POWER:LREFerence?.....	521
:TRACe<ch>[:POWER]:SWEep:MEASurement:POWER:MAXimum?.....	521
:TRACe<ch>[:POWER]:SWEep:MEASurement:POWER:MINimum?.....	521
:TRACe<ch>[:POWER]:SWEep:MEASurement:POWER:PULSe:BASE?.....	521
:TRACe<ch>[:POWER]:SWEep:MEASurement:POWER:PULSe:TOP?.....	521
:TRACe<ch>[:POWER]:SWEep:MEASurement:POWER:REFerence?.....	521
:TRACe<ch>[:POWER]:SWEep:MEASurement:PULSe:DCYClE?.....	521
:TRACe<ch>[:POWER]:SWEep:MEASurement:PULSe:DURation?.....	521
:TRACe<ch>[:POWER]:SWEep:MEASurement:PULSe:PERiod?.....	521
:TRACe<ch>[:POWER]:SWEep:MEASurement:PULSe:SEPARation?.....	521
:TRACe<ch>[:POWER]:SWEep:MEASurement:PULSe:STATe?.....	521
:TRACe<ch>[:POWER]:SWEep:MEASurement:TRANSition:NEGative:DURation?.....	521
:TRACe<ch>[:POWER]:SWEep:MEASurement:TRANSition:NEGative:OCCurrence?.....	521
:TRACe<ch>[:POWER]:SWEep:MEASurement:TRANSition:NEGative:OVERshoot?.....	521
:TRACe<ch>[:POWER]:SWEep:MEASurement:TRANSition:POSitive:DURation?.....	521
:TRACe<ch>[:POWER]:SWEep:MEASurement:TRANSition:POSitive:OCCurrence?.....	521
:TRACe<ch>[:POWER]:SWEep:MEASurement:TRANSition:POSitive:OVERshoot?.....	521
:TRACe<ch>[:POWER]:SWEep:MEASurement:PULSe:DCYClE:DISPlay:ANNotation[: STATe].....	522

## Power Sensor Measurement Subsystems

:TRACe<ch>[:POWer]:SWEep:MEASurement:PULSe:DURation:DISPlay:ANNotation[:STATE].....	522
:TRACe<ch>[:POWer]:SWEep:MEASurement:PULSe:PERiod:DISPlay:ANNotation[:STATE].....	522
:TRACe<ch>[:POWer]:SWEep:MEASurement:POWer:AVERage:DISPlay:ANNotation[:STATE].....	522
:TRACe<ch>[:POWer]:SWEep:MEASurement:POWer:PULSe:BASE:DISPlay:ANNotation[:STATE].....	522
:TRACe<ch>[:POWer]:SWEep:MEASurement:POWer:HREFerence:DISPlay:ANNotation[:STATE].....	522
:TRACe<ch>[:POWer]:SWEep:MEASurement:POWer:LREFerence:DISPlay:ANNotation[:STATE].....	522
:TRACe<ch>[:POWer]:SWEep:MEASurement:POWer:MAXimum:DISPlay:ANNotation[:STATE].....	522
:TRACe<ch>[:POWer]:SWEep:MEASurement:POWer:MINimum:DISPlay:ANNotation[:STATE].....	522
:TRACe<ch>[:POWer]:SWEep:MEASurement:POWer:REFerence:DISPlay:ANNotation[:STATE].....	522
:TRACe<ch>[:POWer]:SWEep:MEASurement:POWer:PULSe:TOP:DISPlay:ANNotation[:STATE].....	522
:TRACe<ch>[:POWer]:SWEep:MEASurement:PULSe:SEPARation:DISPlay:ANNotation[:STATE].....	522
:TRACe<ch>[:POWer]:SWEep:MEASurement:TRANSition:NEGative:DURation:DISPlay:ANNotation[:STATE].....	522
:TRACe<ch>[:POWer]:SWEep:MEASurement:TRANSition:NEGative:OCCurrence:DISPlay:ANNotation[:STATE].....	522
:TRACe<ch>[:POWer]:SWEep:MEASurement:TRANSition:NEGative:OVERshoot:DISPlay:ANNotation[:STATE].....	522
:TRACe<ch>[:POWer]:SWEep:MEASurement:TRANSition:POSitive:DURation:DISPlay:ANNotation[:STATE].....	522
:TRACe<ch>[:POWer]:SWEep:MEASurement:TRANSition:POSitive:OCCurrence:DISPlay:ANNotation[:STATE].....	523
:TRACe<ch>[:POWer]:SWEep:MEASurement:TRANSition:POSitive:OVERshoot:DISPlay:ANNotation[:STATE].....	523
:TRACe<ch>[:POWer]:SWEep:MEASurement:PULSe:ALL:DISPlay:ANNotation[:STATE].....	523
:TRACe<ch>[:POWer]:SWEep:PULSe:THReshold:BASE?.....	523
:TRACe<ch>[:POWer]:SWEep:PULSe:THReshold:POWer:HREFerence.....	524
:TRACe<ch>[:POWer]:SWEep:PULSe:THReshold:POWer:LREFerence.....	524
:TRACe<ch>[:POWer]:SWEep:PULSe:THReshold:POWer:REFerence.....	524
:TRACe<ch>[:POWer]:SWEep:STATE.....	525
:TRACe[:POWer]:SWEep:MEASurement:FULLscreen:DISPlay:ANNotation[:STATE].....	525
:TRACe[:POWer]:SWEep:MEASurement:GATE:DISPlay:ANNotation[:STATE].....	526
:TRACe[:POWer]:SWEep:MEASurement:MARKer:DISPlay:ANNotation[:STATE].....	526
:TRACe[:POWer]:SWEep:MEASurement:PULSe:DISPlay:ANNotation[:STATE].....	526
:TRACe[:POWer]:SWEep:MEASurement:STANdard:DISPlay:ANNotation[:STATE].....	527

---

**:TRACe<ch>[:POWer]:SWEep:COLor <Color>**

Defines the color of a trace.

**Parameters:**

<Color> INVers | GRAY | YELLow | BLUE | GREen | RED | MAGenta  
 \*RST: trace 1 = YELLow, trace 2 = GREen, trace 3 = RED.

**Example:**

TRAC2:SWE:COL GRAY  
 Trace2 is indicated in gray color.

**Manual operation:** See "[Color - Trace Power Analysis](#)" on page 247

**:TRACe<ch>[:POWER]:SWEep:COPIY <Copy>**

Stores the selected trace data as reference trace.

**Setting parameters:**

<Copy> REFerence

**Example:**

TRAC2:SWE:COPIY REF  
 Stores the current trace2 as reference trace'  
 TRAC1:SWE:FEED REF  
 Assigns the reference trace to trace 1.

**Usage:** Setting only

**Manual operation:** See "[Indication - Trace Power Analysis](#)" on page 247

**:TRACe<ch>[:POWER]:SWEep:DATA:POINts?**

Queries the number of measurement points of the selected trace of the current power analysis.

**Return values:**

<Points> integer  
 Range: 10 to 1000  
 \*RST: 0

**Example:**

TRAC1:SWE:DATA:POIN?  
 Response: 624  
 Measurement trace 1 contains 624 measurement points

**Usage:** Query only

**:TRACe<ch>[:POWER]:SWEep:DATA:XVALues?**

Queries the x-axis values - frequency, power or time values - of the selected trace of the current power analysis.

**Return values:**

<XValues> string

**Example:**           SENS:SWE:MODE FREQ  
Sets measurement mode frequency versus power.  
SENS:SWE:RMOD SING  
Selects single measurement.  
SENS:SWE:INIT  
Starts the measurement.  
\*OPC?  
Waits until measurement is performed.  
TRAC1:SWE:DATA:XVAL?  
Queries the x-axis values of trace 1.  
TRAC1:SWE:DATA:YVAL?  
Queries the y-axis values of trace 1

**Usage:**            Query only

**:TRACe<ch>[:POWer]:SWEep:DATA:YSValue? <XValue>**

For a given x-axis value, queries the measurement (y-axis) value of the selected trace of the current power analysis.

**Query parameters:**

<XValue>           float

**Return values:**

<YSValue>         float

Increment: 1E-9

**Example:**           TRACe1:SWE:DATA:YSValue? 2.3

**Example:**           Queries the y-axis values of trace 1 at x-axis value of 2.3.  
See [:TRACe<ch>\[:POWer\]:SWEep:DATA:XVALues?](#)  
on page 519.

**Usage:**            Query only

**:TRACe<ch>[:POWer]:SWEep:DATA:YVALues?**

Queries the measurement (y-axis) values of the selected trace of the current power analysis.

**Return values:**

<YValues>         string

**Example:**

SENS:SWE:TRAC2:DATA:YVAL?

Queries the power values of trace 2.

See [:TRACe<ch>\[:POWer\]:SWEep:DATA:XVALues?](#)  
on page 519.

**Usage:**            Query only

**:TRACe<ch>[:POWer]:SWEep:FEED <Feed>**

Selects the source for the trace data.

**Parameters:**

&lt;Feed&gt;

SENS1 | SENS2 | SENS3 | REFERENCE | NONE | SENSOR1 |  
SENSOR2 | SENSOR3 | SENS4 | SENSOR4

\*RST: The preset value for each trace is evaluated during runtime as follows: If a sensor is plugged into the generator whose number corresponds to the trace number, this sensor is used to feed the trace and the state of the trace is ON; If no sensor is found with number corresponding to the trace number, the preset value of the trace is "Off".

**Example:**

TRAC2:SWE:COPY REF

Stores trace2 as reference trace.

TRAC1:SWE:FEED REF

Assigns the reference trace to trace 1.

TRAC1:SWE:STAT ON

Assigns the reference trace to trace 1.

SENS:SWE:RMOD SING

Selects single measurement

SENS:SWE:INIT

Starts the measurement

**Manual operation:** See "[Indication - Trace Power Analysis](#)" on page 247

---

```

:TRACe<ch>[:POWER]:SWEep:MEASurement:POWER:AVERAge?
:TRACe<ch>[:POWER]:SWEep:MEASurement:POWER:HREFERENCE?
:TRACe<ch>[:POWER]:SWEep:MEASurement:POWER:LREFERENCE?
:TRACe<ch>[:POWER]:SWEep:MEASurement:POWER:MAXimum?
:TRACe<ch>[:POWER]:SWEep:MEASurement:POWER:MINimum?
:TRACe<ch>[:POWER]:SWEep:MEASurement:POWER:PULSE:BASE?
:TRACe<ch>[:POWER]:SWEep:MEASurement:POWER:PULSE:TOP?
:TRACe<ch>[:POWER]:SWEep:MEASurement:POWER:REFERENCE?
:TRACe<ch>[:POWER]:SWEep:MEASurement:PULSE:DCYCLE?
:TRACe<ch>[:POWER]:SWEep:MEASurement:PULSE:DURATION?
:TRACe<ch>[:POWER]:SWEep:MEASurement:PULSE:PERIOD?
:TRACe<ch>[:POWER]:SWEep:MEASurement:PULSE:SEPARATION?
:TRACe<ch>[:POWER]:SWEep:MEASurement:PULSE:STATE?
:TRACe<ch>[:POWER]:SWEep:MEASurement:TRANSition:NEGative:DURATION?
:TRACe<ch>[:POWER]:SWEep:MEASurement:TRANSition:NEGative:
  OCCurrence?
:TRACe<ch>[:POWER]:SWEep:MEASurement:TRANSition:NEGative:OVERshoot?
:TRACe<ch>[:POWER]:SWEep:MEASurement:TRANSition:POSitive:DURATION?
:TRACe<ch>[:POWER]:SWEep:MEASurement:TRANSition:POSitive:OCCurrence?
:TRACe<ch>[:POWER]:SWEep:MEASurement:TRANSition:POSitive:OVERshoot?

```

The above listed commands query the measured pulse parameter values.

**Note:** These commands are only available in time measurement mode and with R&S NRP-Z81 power sensors.

**Return values:**

<Overshoot> float  
 Range: 0 to 100  
 Increment: 0.01  
 \*RST: 0

**Example:**

TRAC1 : SWE : MEAS : POW : HREF ?  
 Queries the measured mesial threshold level of trace 1.  
 TRAC3 : SWE : MEAS : POW : MAX ?  
 Queries the measured peak power of trace 3.

**Usage:** Query only

**Options:** Option R&S SMAB-K28

**Manual operation:** See "[Overshoot \(Rising Edge / Falling Edge\)](#)" on page 264

---

```

:TRACe<ch>[:POWer]:SWEep:MEASurement:PULSe:DCYClE:DISPlay:
  ANNotation[:STATe] <State>
:TRACe<ch>[:POWer]:SWEep:MEASurement:PULSe:DURation:DISPlay:
  ANNotation[:STATe] <State>
:TRACe<ch>[:POWer]:SWEep:MEASurement:PULSe:PERiod:DISPlay:
  ANNotation[:STATe] <State>
:TRACe<ch>[:POWer]:SWEep:MEASurement:POWer:AVERage:DISPlay:
  ANNotation[:STATe] <State>
:TRACe<ch>[:POWer]:SWEep:MEASurement:POWer:PULSe:BASE:DISPlay:
  ANNotation[:STATe] <State>
:TRACe<ch>[:POWer]:SWEep:MEASurement:POWer:HREFerence:DISPlay:
  ANNotation[:STATe] <State>
:TRACe<ch>[:POWer]:SWEep:MEASurement:POWer:LREFerence:DISPlay:
  ANNotation[:STATe] <State>
:TRACe<ch>[:POWer]:SWEep:MEASurement:POWer:MAXimum:DISPlay:
  ANNotation[:STATe] <State>
:TRACe<ch>[:POWer]:SWEep:MEASurement:POWer:MINimum:DISPlay:
  ANNotation[:STATe] <State>
:TRACe<ch>[:POWer]:SWEep:MEASurement:POWer:REFerence:DISPlay:
  ANNotation[:STATe] <State>
:TRACe<ch>[:POWer]:SWEep:MEASurement:POWer:PULSe:TOP:DISPlay:
  ANNotation[:STATe] <State>
:TRACe<ch>[:POWer]:SWEep:MEASurement:PULSe:SEPARation:DISPlay:
  ANNotation[:STATe] <State>
:TRACe<ch>[:POWer]:SWEep:MEASurement:TRANSition:NEGative:DURation:
  DISPlay:ANNotation[:STATe] <State>
:TRACe<ch>[:POWer]:SWEep:MEASurement:TRANSition:NEGative:OCCurrence:
  DISPlay:ANNotation[:STATe] <State>
:TRACe<ch>[:POWer]:SWEep:MEASurement:TRANSition:NEGative:OVERshoot:
  DISPlay:ANNotation[:STATe] <State>
:TRACe<ch>[:POWer]:SWEep:MEASurement:TRANSition:POSitive:DURation:
  DISPlay:ANNotation[:STATe] <State>

```

**:TRACe<ch>[:POWer]:SWEep:MEASurement:TRANSition:POSitive:OCCurrence:DISPlay:ANNotation[:STATe] <State>**

**:TRACe<ch>[:POWer]:SWEep:MEASurement:TRANSition:POSitive:OVERshoot:DISPlay:ANNotation[:STATe] <State>**

The above listed commands select the pulse parameters which are indicated in the display and hardcopy file. Only six parameters can be indicated at a time.

**Note:** These commands are only available in time measurement mode and with R&S NRP-Z81 power sensors.

**Parameters:**

<State> 0 | 1 | OFF | ON  
\*RST: 0

**Example:**

TRAC:SWE:MEAS:TRAC2:PULS:PER:DISP:ANN ON

Selects the pulse period to be indicated in the display.

TRAC:SWE:MEAS:PULS:DISP:ANN ON

Activates indication of the selected pulse data in the display.

**Options:**

Option R&S SMAB-K28

**Manual operation:** See "[Overshoot \(Rising Edge / Falling Edge\)](#)" on page 264

**:TRACe<ch>[:POWer]:SWEep:MEASurement:PULSe:ALL:DISPlay:ANNotation[:STATe] <State>**

Deactivates the indication of all pulse data of the selected trace. The parameters to be indicated can be selected with the TRAC:SWE:MEAS:... commands. Only six parameters are indicated at a time.

**Note:** This command is only available in time measurement mode and with R&S NRP-Z81 power sensors.

**Parameters:**

<State> 0 | 1 | OFF | ON  
\*RST: 0

**Example:**

TRAC:SWE:MEAS:PULS:ALL:DISP:ANN OFF

Switches the indication of all pulse data off.

**Options:**

Option R&S SMAB-K28

**:TRACe<ch>[:POWer]:SWEep:PULSe:THReshold:BASE?**

Queries how the threshold parameters are calculated.

**Note:** This parameter is only available in time measurement mode and R&S NRP-Z81 power sensors.

**Return values:**

<Base> VOLTage | POWer  
\*RST: VOLTage

- Example:** `TRAC1:SWE:PULS:THR:BAS?`  
Queries the threshold base of pulse data calculation.
- Usage:** Query only
- Manual operation:** See " [Base](#) " on page 260

**:TRACe<ch>[:POWer]:SWEep:PULSe:THReshold:POWer:HREFerence**  
<HReference>

Queries the upper threshold level of the overall pulse level. The distal power defines the end of the rising edge and the start of the falling edge of the pulse.

**Note:** This parameter is only available in time measurement mode and R&S NRP-Z81 power sensors.

**Parameters:**

<HReference>	float
Range:	0.0 to 100.0
Increment:	0.01
*RST:	90.0

**Example:** `TRAC2:SWE:PULS:THR:POW:HREF?`  
Queries the upper reference level of trace 2.

**Manual operation:** See " [Distal](#) " on page 261

**:TRACe<ch>[:POWer]:SWEep:PULSe:THReshold:POWer:LREFerence**  
<LReference>

Queries the lower medial threshold level of the overall pulse level. The proximal power defines the start of the rising edge and the end of the falling edge of the pulse.

**Note:** This parameter is only available in time measurement mode and R&S NRP-Z81 power sensors.

**Parameters:**

<LReference>	float
Range:	0.0 to 100.0
Increment:	0.01
*RST:	10.0

**Example:** `TRAC:SWE:PULS:THR:POW:LREF?`  
Queries the medial threshold level of trace 1.

**Manual operation:** See " [Proximal](#) " on page 261

**:TRACe<ch>[:POWer]:SWEep:PULSe:THReshold:POWer:REFerence** <Reference>

Queries the medial threshold level of the overall pulse level. This level is used to define the pulse width and pulse period.



**Note:** This parameter is only available in time measurement mode and R&S NRP-Z81 power sensors.

**Parameters:**

<Reference> float  
 Range: 0.0 to 100.0  
 Increment: 0.01  
 \*RST: 50.0

**Example:**

TRAC3:SWE:PULS:THR:POW:REF?  
 Queries the medial threshold level of trace 3.

**Manual operation:** See " [Mesial](#) " on page 261

**:TRACe<ch>[:POWer]:SWEep:STATe <State>**

Activates the selected trace.

**Parameters:**

<State> OFF | ON | HOLD  
 \*RST: The preset value for each trace is evaluated during runtime as follows: If a sensor is plugged into the generator whose number corresponds to the trace number, this sensor is used to feed the trace and the state of the trace is ON; If no sensor is found with a number corresponding to the trace number, the preset value of the trace is "Off".

**Example:**

TRAC2:SWE:COPI REF  
 Stores trace2 as reference trace.  
 TRAC1:SWE:FEED REF  
 Assigns the reference trace to trace 1.  
 TRAC1:SWE:STAT ON  
 Assigns the reference trace to trace 1.  
 SENS:SWE:RMOD SING  
 Selects single measurement.  
 SENS:SWE:INIT  
 Starts the measurement.

**Manual operation:** See " [Indication - Trace Power Analysis](#)" on page 247

**:TRACe[:POWer]:SWEep:MEASurement:FULLscreen:DISPlay:ANNotation[:STATe] <State>**

Selects fullscreen display of the measurement diagram on the display and in the hard-copy file.

**Parameters:**

<State> 0 | 1 | OFF | ON  
 \*RST: 1

- Example:** TRAC:SWE:MEAS:FULL:DISP:ANN ON  
The display only shows the diagram.
- Options:** Option R&S SMAB-K28
- Manual operation:** See "[Full Screen](#)" on page 273

**:TRACe[:POWer]:SWEep:MEASurement:GATE:DISPlay:ANNotation[:STATe]**  
<State>

Activates the indication of the time gate borders and values in the measurement diagram and in the hardcopy file. The gate settings are performed with the CALC:POW:SWE:TIME:GATE:... commands.

**Parameters:**  
<State> 0 | 1 | OFF | ON  
\*RST: 1

- Example:** TRAC:SWE:MEAS:GATE:DISP:ANN ON  
The diagram also shows the gate information.
- Options:** Option R&S SMAB-K28
- Manual operation:** See "[State - Gate](#)" on page 270

**:TRACe[:POWer]:SWEep:MEASurement:MARKer:DISPlay:ANNotation[:STATe]**  
<State>

Activates the indication of the markers and the marker list in the measurement diagram and in the hardcopy file.

**Parameters:**  
<State> 0 | 1 | OFF | ON  
\*RST: 1

- Example:** TRAC:SWE:MEAS:MARK:DISP:ANN ON  
The diagram also shows the marker information.
- Options:** Option R&S SMAB-K28
- Manual operation:** See "[Marker View](#)" on page 271

**:TRACe[:POWer]:SWEep:MEASurement:PULSe:DISPlay:ANNotation[:STATe]**  
<State>

Activates the indication of the pulse data below the measurement diagram and storing the data in the hardcopy file. The parameters to be indicated can be selected with the following TRAC:SWE:MEAS:... commands. Only six parameters are indicated at one time.

**Note:** This command is only available in time measurement mode and with R&S NRPZ81 power sensors.

**Parameters:**

<State> 0 | 1 | OFF | ON  
 \*RST: 1

**Example:**

TRAC:SWE:MEAS:PULS:DISP:ANN ON  
 Activates indication of the selected pulse data.

**Options:**

Option R&S SMAB-K28

**Manual operation:** See "[Pulse Data View](#)" on page 272

**:TRACe[:POWer]:SWEep:MEASurement:STANdard:DISPlay:ANNotation[:STATe]**  
 <State>

Selects the standard view, i.e. diagram and buttons but no lists are displayed and also stored in the hardcopy file.

**Parameters:**

<State> 0 | 1 | OFF | ON  
 \*RST: 1

**Example:**

TRAC:SWE:MEAS:STAN:DISP:ANN ON  
 Activates indication of the selected pulse data.

**Options:**

Option R&S SMAB-K28

**Manual operation:** See "[Standard View](#)" on page 271

## 14.15 SENSe, READ, INITiate and SLISt Subsystems

These subsystems contain the commands for configuring the power measurements with R&S NRP power sensor connected to the R&S SMA100B.



The local state is set with the `INIT` command. Switching off the local state enhances the measurement performance. Measurements results can be retrieved in local state on or off.

Sensor parameters are set with the `SENSe` commands.

To start the measurement and retrieve the result, use the `:READ<ch>[:POWer]?` command.

## SENSe, READ, INITiate and SLISt Subsystems

Suffix	Value range	Description
SENSe<ch>	[1] to 4	Indicates the sensor Sensor mapping: <ul style="list-style-type: none"> <li>• SENSe[1] - default mapping for sensors connected to the [Sensor] connector</li> <li>• SENSe2 - sensor connected to a [USB] connector</li> <li>• SENSe3 4 - further connected sensors to [USB] connectors, in the connection order</li> </ul> Use the :SLISt commands to change the sensor mapping
READ<ch>	[1] to 4	Sensor assignment
INITiate<hw>	[1] to 4	Sensor assignment
ELEMent<ch>	[1] to 25	Sensor mapping list

## Programming examples

### Example: Detecting and assigning a power sensor

```

SLISt:LIST?
// Response: "NRP33SN-V-900007-USB Legacy","NRP-Z211-900001-USB Legacy"
// list of automatically detected sensors

SLISt:SCAN:STATe 1
// searches for sensors connected in the LAN or via the USBTMC protocol

:SLISt:SCAN:LENSor 'NRQ6',101624 //sensor name, serial number
:SLISt:SCAN:LENSor 'NRQ6',11.123.1.123, 101624 //IP address, serial number
// add sensor connected in the LAN to the list

:SLISt:SCAN:USENSor 'NRQ6',101624 //sensor name, serial number
:SLISt:SCAN:USENSor #H15b,101624 //device ID (hexadecimal), serial number
:SLISt:SCAN:USENSor 347,101624 //device ID (decimal), serial number
// add sensor connected at the USB interface to the list

SLISt:LIST?
// Response:
// "NRP33SN-V-900007-USB Legacy","NRP-Z211-900001-USB Legacy",
// "NRP33SN-V-900005-USBTMC","NRP33SN-V-900011-LAN"
// list of automatically detected sensors
// the list can contain more entries

SLISt:ELEMent3:MAPPing SENS1
// maps the third sensor from the list to the first sensor channel

SLISt:SENSor:MAP "NRPS18S-100654-USB Legacy", SENS3
// maps the sensor directly to channel 3

:SLISt:CLEar[ALL] // remove all sensors from the list
:SLISt:CLEar:LAN // remove sensors connected in the LAN from the list
:SLISt:CLEar:USB // remove sensors connected over USB from the list
// remove all sensors from the list

```

### Example: Performing a simple power measurement

Prerequisite: The sensor is connected to the instrument and mapped to the first sensor channel.

```

:INITiate1:CONTinuous ON
//Switches the continuous power measurement on

:READ1?
// Triggers the measurement and displays the results

```

**Example: Performing a power measurement with a fixed filter**

Prerequisite: The sensor is connected to the instrument and mapped to the first sensor channel.

```

SENSe1:SOURce RF
//Sensor measures the power of the RF signal

SENSe1:FILTer:TYPE NSRatio
//Selects fixed noise filter mode

SENSe1:FILTer:NSRatio 0.02 DB
//Sets the maximum noise component in the result to 0.02 DB

SENSe1:FILTer:NSRatio:MTIME 10
//Limits the settling time to 10 seconds.

:SENSe1:APERTure:DEFault:STATe 0
// Deactivates the default aperture time of the sensor

:SENSe1:APERTure:TIME 10e-6
// Sets the aperture time to 10 us

SENSe1:UNIT DBM
//Selects unit dBm for the measured value

:INITiate:CONTinuous ON
//Switches the continous power measurement on

:READ?
//Triggers the measurement and displays the results

```

:SLISt[:LIST]?.....	531
:SLISt:SCAN[:STATe].....	531
:SLISt:SCAN:LSEnSor.....	531
:SLISt:SCAN:USEnSor.....	532
:SLISt:CLEar:LAN.....	532
:SLISt:CLEar:USB.....	532
:SLISt:CLEar[:ALL].....	532
:SLISt:ELEMent<ch>:MAPPing.....	533
:SLISt:SENsOr:MAP.....	533
:INITiate<hw>[:POWer]:CONTinuous.....	533
:READ<ch>[:POWer]?.....	534
:SENSe<ch>:UNIT[:POWer].....	534
:SENSe<ch>[:POWer]:APERTure:DEFault:STATe.....	535
:SENSe<ch>[:POWer]:APERTure:TIME.....	535
:SENSe<ch>[:POWer]:CORRection:SPDevice:SELect.....	535
:SENSe<ch>[:POWer]:CORRection:SPDevice:STATe.....	536
:SENSe<ch>[:POWer]:CORRection:SPDevice:LIST?.....	536
:SENSe<ch>[:POWer]:DISPlay:PERManent:PRiority.....	536
:SENSe<ch>[:POWer]:DISPlay:PERManent:STATe.....	536

:SENSe<ch>[:POWer]:FILTer:LENGTh:AUTO?	537
:SENSe<ch>[:POWer]:FILTer:LENGTh[:USER]	537
:SENSe<ch>[:POWer]:FILTer:NSRatio	538
:SENSe<ch>[:POWer]:FILTer:NSRatio:MTIME	538
:SENSe<ch>[:POWer]:FILTer:SONCe	538
:SENSe<ch>[:POWer]:FILTer:TYPE	539
:SENSe<ch>[:POWer]:FREQUency	539
:SENSe<ch>[:POWer]:LOGGing:STATe	540
:SENSe<ch>[:POWer]:OFFSet	540
:SENSe<ch>[:POWer]:OFFSet:STATe	540
:SENSe<ch>[:POWer]:SNUMber?	540
:SENSe<ch>[:POWer]:SOURce	541
:SENSe<ch>[:POWer]:STATus[:DEVice]?	541
:SENSe<ch>[:POWer]:SVERsion?	541
:SENSe<ch>[:POWer]:TYPE?	542
:SENSe<ch>[:POWer]:ZERO	542

---

### :SLISt[:LIST]?

Returns a list of all detected sensors in a comma-separated string.

#### Return values:

<SensorList>                      String of comma-separated entries  
 Each entry contains information on the sensor type, serial number and interface.  
 The order of the entries does not correspond to the order the sensors are displayed in the "NRP Sensor Mapping" dialog.

**Example:**                      See [Example "Detecting and assigning a power sensor"](#) on page 529.

**Usage:**                              Query only

**Manual operation:**    See "[Sensor Mapping List](#)" on page 231

---

### :SLISt:SCAN[:STATe] <State>

Starts the search for R&S NRP power sensors, connected in the LAN or via the USBTMC protocol.

#### Parameters:

<State>                              0 | 1 | OFF | ON  
 \*RST:                                0

**Example:**                      See [Example "Detecting and assigning a power sensor"](#) on page 529.

**Manual operation:**    See "[Scan](#)" on page 232

---

### :SLISt:SCAN:LSEnsor <IP>

Scans for R&S NRP power sensors connected in the LAN.

**Setting parameters:**

<IP> string  
 \*RST: 0

**Example:** See [Example "Detecting and assigning a power sensor"](#) on page 529.

**Usage:** Setting only

**Manual operation:** See "[Add LAN Sensor settings](#)" on page 232

**:SLISt:SCAN:USENSor** <DeviceID>, <Serial>

Scans for R&S NRP power sensors connected over a USB interface.

**Parameters:**

<Serial> integer  
 Range: 0 to 999999

**Setting parameters:**

<DeviceID> String or Integer  
 Range: 0 to 999999  
 \*RST: 0

**Example:** See [Example "Detecting and assigning a power sensor"](#) on page 529.

**Usage:** Setting only

**Manual operation:** See "[Add USB Sensor settings](#)" on page 232

**:SLISt:CLEAr:LAN**

Removes all R&S NRP power sensors connected in the LAN from the list.

**Example:** See [Example "Detecting and assigning a power sensor"](#) on page 529.

**Usage:** Event

**:SLISt:CLEAr:USB**

Removes all R&S NRP power sensors connected over USB from the list.

**Example:** See [Example "Detecting and assigning a power sensor"](#) on page 529.

**Usage:** Event

**:SLISt:CLEAr[:ALL]**

Removes all R&S NRP power sensors from the list.



**Example:** See [Example "Detecting and assigning a power sensor"](#) on page 529.

**Usage:** Event

**:SLISt:ELEMent<ch>:MAPPing <Mapping>**

Assigns an entry from the `:SLISt[:LIST]?` to one of the four sensor channels.

**Parameters:**

<Mapping> SENS1 | SENSor1 | SENS2 | SENSor2 | SENS3 | SENSor3 | SENS4 | SENSor4 | UNMapped

Sensor channel.

\*RST: UNMapped

**Example:** See [Example "Detecting and assigning a power sensor"](#) on page 529.

**Manual operation:** See "[Sensor Mapping List](#)" on page 231

**:SLISt:SENSor:MAP <SensorId>, <Mapping>**

Assigns a sensor directly to one of the sensor channels, using the sensor name and serial number.

To find out the the sensor name and ID, you can get it from the label of the R&S NRP, or using the command `:SLISt:SCAN[:STATe]`. This command detects all R&S NRP power sensors connected in the LAN or via 'USBTMC protocol.

**Setting parameters:**

<SensorId> string

<Mapping> enum

**Example:** See [Example "Detecting and assigning a power sensor"](#) on page 529.

**Usage:** Setting only

**Manual operation:** See "[Sensor Mapping List](#)" on page 231

**:INITiate<hw>[:POWER]:CONTInuous <Continuous>**

Switches the local state of the continuous power measurement by R&S NRP power sensors on and off. Switching off local state enhances the measurement performance during remote control.

The remote measurement is triggered with `:READ<ch>[:POWER]?`. This command also returns the measurement results. The local state is not affected, measurement results can be retrieved with local state on or off.

**Parameters:**

<Continuous> 0 | 1 | OFF | ON

\*RST: 0

**Example:** INIT1:CONT ON  
Switches local state of continuous power measurement on.

**Manual operation:** See " [State](#) " on page 237

### :READ<ch>[:POWER]?

Triggers power measurement and displays the results.

**Note:** This command does not affect the local state, i.e. you can get results with local state on or off. For long measurement times, we recommend that you use an SRQ for command synchronization (MAV bit).

**Suffix:**

<ch> 1 to 3

**Return values:**

<Power> float or float,float

The sensor returns the result in the unit set with command :

[SENSe<ch>:UNIT\[:POWER\]](#)

Certain power sensors, such as the R&S NRP-Z81, return two values, first the value of the average level and - separated by a comma - the peak value.

**Example:**

SENS1:UNIT DBM

Selects unit dBm for presentation of measurement result.

READ1?

Queries the measurement result of the sensor.

-45.6246576745440230

-45.6 dBm were measured at the given frequency.

**Example:**

R&S NRP-Z81

READ1?

-55.62403263352178, -22.419472478812476

-55.6 dBm is the measured average level, -22.4 dBm is the measured peak level at the given frequency.

**Usage:**

Query only

**Manual operation:** See " [Level \(Peak\) / Level \(Average\)](#) " on page 236

### :SENSe<ch>:UNIT[:POWER] <Power>

Selects the unit (Watt, dBm or dBµV) of measurement result display, queried with :  
[READ<ch>\[:POWER\]?](#).

**Parameters:**

<Power> DBM | DBUV | WATT

\*RST: DBM

**Example:**           SENS2:UNIT DBM  
 Selects dBm as unit for the measured value returned by command READ.  
 READ2?  
 Response: 7.34  
 7.34 dBm are measured by sensor 2.

**Manual operation:** See "[Level \(Peak\) / Level \(Average\)](#)" on page 236

**:SENSe<ch>[:POWer]:APERture:DEFault:STATe <UseDefAp>**

Deactivates the default aperture time of the respective sensor.

To specify a user-defined value, use the command **:SENSe<ch>[:POWer]:APERture:TIME** on page 535.

**Parameters:**  
 <UseDefAp>           0 | 1 | OFF | ON  
 \*RST:                1

**Example:**           See [Example "Performing a power measurement with a fixed filter"](#) on page 530.

**Manual operation:** See "[Default Aperture Time](#)" on page 239

**:SENSe<ch>[:POWer]:APERture:TIME <ApTime>**

Defines the aperture time (size of the acquisition interval) for the corresponding sensor.

**Parameters:**  
 <ApTime>           float  
 Range:            depends on connected power sensor  
 Increment:       1E-9  
 \*RST:            depends on connected power sensor

**Example:**           See [Example "Performing a power measurement with a fixed filter"](#) on page 530.

**Manual operation:** See "[Aperture Time](#)" on page 239

**:SENSe<ch>[:POWer]:CORRection:SPDevice:SELEct <Select>**

Several S-parameter tables can be stored in a sensor. The command selects a loaded data set for S-parameter correction for the corresponding sensor.

**Parameters:**  
 <Select>           float  
 \*RST:            0

**Manual operation:** See "[S-Parameter](#)" on page 240

---

**:SENSe<ch>[:POWer]:CORRection:SPDevice:STATe <State>**

Activates the use of the S-parameter correction data.

**Note:** If you use power sensors with attenuator, the instrument automatically activates the use of S-parameter data.

**Parameters:**

<State>            0 | 1 | OFF | ON  
 \*RST:            0

**Example:**            SENSE1:POWer:CORRection:SPDevice:STATe 1  
 Activates the use of the S-parameters correction data.

**Manual operation:**    See " S-Parameter " on page 240

---

**:SENSe<ch>[:POWer]:CORRection:SPDevice:LIST?**

Queries the list of the S-parameter data sets that have been loaded to the power sensor.

**Return values:**

<List>            string list  
 \*RST:            0

**Usage:**            Query only

**Manual operation:**    See " S-Parameter " on page 240

---

**:SENSe<ch>[:POWer]:DISPlay:PERManent:PRiority <Priority>**

Selects average or peak power for permanent display.

**Parameters:**

<Priority>            AVERAge | PEAK  
 \*RST:            AVERAge

**Example:**            SENS1:DISP:PERM:STAT ON  
 Turns on the permanent view.  
 SENS1:DISP:PERM:PRI AVER  
 Sets the average power for display.

**Manual operation:**    See " Display " on page 237

---

**:SENSe<ch>[:POWer]:DISPlay:PERManent:STATe <State>**

Activates the permanent display of the measured power level results. The instrument also indicates the sensor type, the connection, the measurement source and the offset if set.

**Parameters:**

<State>            0 | 1 | OFF | ON  
 \*RST:            0

**Example:**                `SENS1:POW:DISP:PERM:STAT ON`  
Turns on the permanent view.

**Manual operation:**   See " [Permanent](#) " on page 237

#### **:SENSe<ch>[:POWer]:FILTer:LENGth:AUTO?**

Queries the current filter length in filter mode `AUTO` (`:SENSe<ch>[:POWer]:FILTer:TYPE`)

**Return values:**

<Auto>                    float  
Range:                    1 to 65536

**Example:**                `SENS1:FILT:TYPE AUTO`  
Selects auto filter.  
`SENS1:FILT:LENG:AUTO?`  
Queries the automatically set filter length.  
Response: 1024

**Usage:**                    Query only

**Manual operation:**   See " [Filter Length](#) " on page 239

#### **:SENSe<ch>[:POWer]:FILTer:LENGth[:USER] <User>**

Selects the filter length for `SENS:POW:FILT:TYPE USER`. As the filter length works as a multiplier for the time window, a constant filter length results in a constant measurement time (see also "[About the measuring principle, averaging filter, filter length, and achieving stable results](#)" on page 233).

The R&S NRP power sensors provide different resolutions for setting the filter length, depending on the used sensor type:

- Resolution = 1 for R&S NRPxx power sensors
- Resolution =  $2^n$  for sensors of the R&S NRP-Zxx family, with  $n = 1$  to 16

**Parameters:**

<User>                    float  
Range:                    1 to 65536  
\*RST:                    1

**Example:**                `SENS1:FILT:TYPE USER`  
Selects user filter mode.  
`SENS1:FILT:LENG 16`  
Sets a filter length of 16. E.g. using a sensor with 20 ms time window, the resulting measurement time is 640 ms ( $2 \times 16 \times 20$  ms)

**Manual operation:**   See " [Filter Length](#) " on page 239

**:SENSe<ch>[:POWer]:FILTer:NSRatio <NSRatio>**

Sets an upper limit for the relative noise content in fixed noise filter mode (:SENSe<ch>[:POWer]:FILTer:TYPE). This value determines the proportion of intrinsic noise in the measurement results.

**Parameters:**

<NSRatio> float  
 Range: 0.001 to 1  
 Increment: 0.001  
 \*RST: 0.01

**Example:** See [Example "Performing a power measurement with a fixed filter"](#) on page 530.

**Manual operation:** See ["Noise/Signal Ratio"](#) on page 239

**:SENSe<ch>[:POWer]:FILTer:NSRatio:MTIME <MTime>**

Sets an upper limit for the settling time of the auto-averaging filter in the NSRatio mode and thus limits the length of the filter. The filter type is set with command :SENSe<ch>[:POWer]:FILTer:TYPE.

**Parameters:**

<MTime> float  
 Range: 1 to 999.99  
 Increment: 0.01  
 \*RST: 4

**Example:** See [Example "Performing a power measurement with a fixed filter"](#) on page 530.

**Manual operation:** See ["Timeout"](#) on page 239

**:SENSe<ch>[:POWer]:FILTer:SONCe**

Starts searching the optimum filter length for the current measurement conditions. You can check the result with command :SENS1:POW:FILT:LENG:USER? in filter mode USER (:SENSe<ch>[:POWer]:FILTer:TYPE).

**Example:**

```
SENS1:FILT:TYPE USER
Selects user filter mode.
SENS1:FILT:SONC
Activates the search for the optimum filter length.
SENS1:FILT:LENG?
Returns the found optimum filter length.
Response: 128
```

**Usage:** Event

**Manual operation:** See ["Auto Once"](#) on page 239

---

```
:SENSe<ch>[:POWer]:FILTer:TYPE <Type>
```

Selects the filter mode. The filter length is the multiplier for the time window and thus directly affects the measurement time.

**Parameters:**

<Type>

AUTO | USER | NSRatio

**AUTO**

Automatically selects the filter length, depending on the measured value. The higher the power, the shorter the filter length, and vice versa.

**USER**

Allows you to set the filter length manually. As the filter-length takes effect as a multiplier of the measurement time, you can achieve constant measurement times.

**NSRatio**

Selects the filter length (averaging factor) according to the criterion that the intrinsic noise of the sensor (2 standard deviations) does not exceed the specified noise content. You can define the noise content with command `:SENSe<ch>[:POWer]:FILTer:NSRatio`.

**Note:** To avoid long settling times when the power is low, you can limit the averaging factor limited with the "timeout" parameter (`:SENSe<ch>[:POWer]:FILTer:NSRatio:MTIME`).

\*RST: AUTO

**Example:** See [Example "Performing a power measurement with a fixed filter"](#) on page 530.

**Manual operation:** See ["Filter"](#) on page 238

---

```
:SENSe<ch>[:POWer]:FREQuency <Frequency>
```

Sets the RF frequency of the signal, if signal source "USER" is selected (`:SENSe<ch>[:POWer]:SOURce`).

**Parameters:**

<Frequency>

float

\*RST: 1 GHz

**Example:**

```
SENS1:SOUR USER
```

Selects user-defined source.

```
SENS1:FREQ 2.44GHZ
```

Sets the RF frequency of the source which is 2.44 GHz.

**Manual operation:** See ["Frequency"](#) on page 238

---

**:SENSe<ch>[:POWer]:LOGGing:STATe <State>**

Activates the recording of the power values, measured by a connected R&S NRP power sensor.

**Parameters:**

<State>                    0 | 1 | OFF | ON  
\*RST:                    0

**Example:**

SENS:LOGG:STAT ON

Activates recording of the power measurement of the first sensor.

**Manual operation:** See "[Enable Logging](#)" on page 240

---

**:SENSe<ch>[:POWer]:OFFSet <Offset>**

Sets a level offset which is added to the measured level value after activation with command `:SENSe<ch>[:POWer]:OFFSet:STATe`. The level offset allows, e.g. to consider an attenuator in the signal path.

**Parameters:**

<Offset>                    float  
Range:                    -100.0 to 100.0  
\*RST:                    0  
Default unit: dB

**Example:**

SENS1:POW:OFFS 10.0

Sets a level offset of 10 dB

**Manual operation:** See "[Level Offset State,Level Offset](#)" on page 238

---

**:SENSe<ch>[:POWer]:OFFSet:STATe <State>**

Activates the addition of the level offset to the measured value. The level offset value is set with command `:SENSe<ch>[:POWer]:OFFSet`.

**Parameters:**

<State>                    0 | 1 | OFF | ON  
\*RST:                    0

**Example:**

SENS1:POW:OFFS 0.4dB

Sets a level offset of 0.4 dB

SENS1:POW:OFFS:STAT ON

A level offset of 0.4 dB is added to the measured value.

**Manual operation:** See "[Level Offset State,Level Offset](#)" on page 238

---

**:SENSe<ch>[:POWer]:SNUMber?**

Queries the serial number of the sensor.



**Return values:**

<SNumber> string

**Example:**

SENS1:SNUM?

Queries the serial number.

**Usage:**

Query only

**Manual operation:** See "[Sensor type and serial number](#)" on page 236

**:SENSe<ch>[:POWer]:SOURce <Source>**

Determines the signal to be measured.

**Note:** When measuring the RF signal, the sensor considers the corresponding correction factor at that frequency, and uses the level setting of the instrument as reference level.

**Parameters:**

<Source> A | USER | RF

\*RST: A

**Example:**

See [Example "Performing a power measurement with a fixed filter"](#) on page 530.

**Manual operation:** See "[Use Frequency Of](#)" on page 237

**:SENSe<ch>[:POWer]:STATus[:DEVice]?**

Queries if a sensor is connected to the instrument.

**Return values:**

<Status> 0 | 1 | OFF | ON

\*RST: 0

**Example:**

SENS1:STAT?

Response: 1

A sensor is connected.

**Usage:**

Query only

**Manual operation:** See "[State](#)" on page 237

**:SENSe<ch>[:POWer]:SVERsion?**

Queries the software version of the connected R&S NRP power sensor.

**Return values:**

<SVersion> string

**Example:**

SENS1:POW:SVER?

Queries the software version of the power sensor.

**Usage:**

Query only

**:SENSe<ch>[:POWer]:TYPE?**

Queries the sensor type. The type is automatically detected.

**Return values:**

<Type> string

**Example:**

SENS1:TYPE?

Queries the type of sensor.

Response: NRP-Z21

The R&S NRP-Z21 sensor is used.

**Usage:** Query only

**Manual operation:** See "[Sensor type and serial number](#)" on page 236

**:SENSe<ch>[:POWer]:ZERO**

Performs zeroing of the sensor.

Zeroing is required after warm-up, i.e. after connecting the sensor.

**Note:** Switch off or disconnect the RF power source from the sensor before zeroing.

We recommend that you zero in regular intervals (at least once a day), if:

- The temperature has varied more than about 5 °C.
- The sensor has been replaced.
- You want to measure very low power.

**Example:**

SENS1:ZERO

Executes zeroing.

**Usage:** Event

**Manual operation:** See "[Zero](#)" on page 237

## 14.16 SOURce Subsystem

The SOURce subsystem contains the commands for configuring the digital and analog signals.

### Common suffixes

The following common suffixes are used in remote commands:

Suffix	Value range	Description
SOURce<hw>	[1]	<ul style="list-style-type: none"> <li>• SOURce[1] = RF output (optional keyword)</li> <li>• LF output = SOURce:LFOutput (SOURce is optional keyword)</li> </ul>

• Analog Modulation Subsystems.....	543
• Avionic Standards Subsystems.....	574
• SOURce:CORRection Subsystem.....	616
• SOURce:FREQuency Subsystem.....	624
• SOURce:INPut Subsystem.....	631
• SOURce:LFOuTput Subsystem.....	632
• SOURce:LIST Subsystem.....	645
• SOURce:NOISe Subsystem.....	657
• SOURce:PGEN Subsystem.....	659
• SOURce:PHASe Subsystem.....	661
• SOURce:POWer Subsystem.....	662
• SOURce:ROSCillator Subsystem.....	671
• SOURce:SWEEP Subsystem.....	676

### 14.16.1 Analog Modulation Subsystems

Option: see [Chapter 5.1, "Required Options"](#), on page 80.

The subsystems in this section describe all commands for analog modulation of the RF signal. Divided in separate sections, you can configure amplitude modulation (AM), frequency modulation (FM), phase modulation (PhiM) and pulse modulation (PULM).

You can perform each of the modulations either with an internally generated modulation signal or with an externally applied signal.

To configure the internal signal, use the commands listed in [Chapter 14.16.6, "SOURce:LFOuTput Subsystem"](#), on page 632.

For more information:

See [Chapter 5, "Analog Modulations"](#), on page 80.

#### 14.16.1.1 SOURce:MODulation Subsystem

The command in this subsystem allows you to disable all active modulations at once, and, vice versa, to restore the last active ones.

---

**[[:SOURce<hw>]:MODulation[:ALL][:STATe] <State>**

Activates all modulations that were active before the last switching off.

**Parameters:**

<State>                    0 | 1 | OFF | ON  
 \*RST:                    0

**Example:**

```

SOURce1:AM1:DEPTH 30
SOURce1:AM1:SOURce LF1
SOURce1:AM1:STATe 1
SOURce1:FM1:DEVIation 1000
SOURce1:FM1:STATe 1
// disable both modulation
SOURce1:MODulation:ALL:STATe 0
SOURce1:AM1:STATe?
// 0
SOURce1:FM1:STATe?
// 0
// enable both modulation
SOURce1:MODulation:ALL:STATe 1
SOURce1:AM1:STATe?
// 1
SOURce1:FM1:STATe?
// 1

```

**Manual operation:** See "[Mod on/off]" on page 82

#### 14.16.1.2 SOURce:AM Subsystem

Option: R&S SMAB-K720

The AM subsystem contains the commands for setting the amplitude modulation and also the broadband amplitude modulation.

The following examples show some variants for generating AM signals.

##### **Example: Creating an amplitude modulated RF signal**

Using the internal LF generator, the following command sequence configures an amplitude modulated signal.

```

// Reset the instrument to start from a defined state
*RST

// Set RF frequency and amplitude
SOURce1:FREQuency:CW 6000000000
SOURce1:POWer:LEVel:IMMediate:AMPLitude -25

// Configure the modulation signal
SOURce1:LFOutput1:SHAPE SINE
SOURce1:LFOutput1:FREQuency 20000

// Configure the amplitude modulation settings and switch AM on
SOURce1:AM1:SOURce LF1
SOURce1:AM1:DEPTH 30
SOURce1:AM:RATio 40
SOURce1:AM1:DEVIation:MODE UNC
SOURce1:AM1:STATe 1

```

**Example: Using combined LF signals**

Using the internal LF generators of both paths, the following command sequences configure an amplitude modulated signal with determined deviations depths.

```
// Configure the AM modulation settings with combined LF signal sources
SOURcel:AM1:SOURce LF1
SOURcel:AM1:DEPTh:LINear 32
// Select the modulation signal source for the second path
SOURcel:AM2:SOURce LF2
// Combine the signals of both paths with fixed total deviation depth
SOURcel:AM1:DEVIation:MODE TOT
SOURcel:AM1:DEPTh:SUM 60

// Query the deviation depth of modulation signal in the second path
SOURcel:AM2:DEPTh:LINear?
// Response: 28

// Combine the signals of both paths with fixed ratio
SOURcel:AM1:DEVIation:MODE RAT
SOURcel:AM1:RATio 100
SOURcel:AM2:DEPTh:LINear 25

// Query the deviation depth of modulation signal in the first path
SOURcel:AM1:DEPTh:LINear?
// Response: 25

SOURcel:AM1:STATe 1
SOURcel:AM2:STATe 1
```

**Example: Using an external signal source**

Using an external signal source, you can additionally determine whether you want to use only the AC component of the external modulation signal.

```
// Reset the instrument to start from a defined state
*RST

// Set frequency and amplitude
SOURcel:FREQuency:CW 6000000000
SOURcel:POWer:LEVel:IMMediate:AMPLitude -25

// Configure the amplitude modulation settings and turn on AM
SOURcel:AM1:SOURce EXT1
SOURcel:AM1:DEPTh 40

// Query the input sensitivity at the external modulation input
SOURcel:AM1:SENSitivity?
// Response: 40
// Since the voltage value for full modulation is 1V,
// the resulting sensitivity is precisely 50%/V.
```

```

// This value is assigned to the voltage value for full
// modulation of the input.

// Select the coupling mode AC for external amplitude modulation
SOURce1:INPut:MODext:COUPling1 AC

// For external AM signal input, adjust the sensitivity
SOURce1:AM1:TYPE EXP
SOURce1:AM1:SOURce EXT1
SOURce1:AM1:SENSitivity 25
SOURce1:AM1:SENSitivity?
Response: 25

// Alternatively use the scan mode for the level behavior of rotating antennas
// SCAN automatically sets the modulation type to exponential
SOURce1:AM1:MODE SCAN
SOURce1:AM1:SOURce EXT2
SOURce1:AM1:DEPTh:EXponential 12
SOURce1:AM1:DEPTh:EXponential?
Response: 12

// Activating the external exponential AM changes the coupling
// in this example for EXT2
INPut:MODext:COUPling2 DC

// Configure the modulation settings

// Switch on AM and RF signal output
SOURce1:AM1:STATe 1
OUTPut1:STATe 1

```

The following commands are available:

<a href="#">[:SOURce&lt;hw&gt;]:AM&lt;ch&gt;:STATe</a> .....	546
<a href="#">[:SOURce&lt;hw&gt;]:AM&lt;ch&gt;:SOURce</a> .....	547
<a href="#">[:SOURce&lt;hw&gt;]:AM&lt;ch&gt;[:DEPTh]</a> .....	547
<a href="#">[:SOURce&lt;hw&gt;]:AM&lt;ch&gt;:DEPTh:LINear</a> .....	547
<a href="#">[:SOURce&lt;hw&gt;]:AM&lt;ch&gt;:DEPTh:EXponential</a> .....	548
<a href="#">[:SOURce&lt;hw&gt;]:AM:MODE</a> .....	548
<a href="#">[:SOURce&lt;hw&gt;]:AM:DEPTh:SUM</a> .....	548
<a href="#">[:SOURce&lt;hw&gt;]:AM:DEVIation:MODE</a> .....	549
<a href="#">[:SOURce&lt;hw&gt;]:AM:RATio</a> .....	549
<a href="#">[:SOURce&lt;hw&gt;]:AM&lt;ch&gt;:SENSitivity:EXponential</a> .....	549
<a href="#">[:SOURce&lt;hw&gt;]:AM&lt;ch&gt;:SENSitivity[:LINear]</a> .....	550
<a href="#">[:SOURce&lt;hw&gt;]:AM:TYPE</a> .....	550

---

**[:SOURce<hw>]:AM<ch>:STATe <State>**

Activates amplitude modulation.

**Parameters:**

<State> 0 | 1 | OFF | ON  
 \*RST: 0

**Example:** See [Example "Creating an amplitude modulated RF signal"](#) on page 544.

**Manual operation:** See ["State"](#) on page 86

**[:SOURce<hw>]:AM<ch>:SOURce <Source>**

Selects the modulation source for amplitude modulation.

**Parameters:**

<Source> LF1 | LF2 | NOISe | EXT1 | EXT2 | EXTeRnal | INTeRnal

**LF1|LF2**

Uses an internally generated LF signal.

**EXT1|EXT2**

Uses an externally supplied LF signal.

**NOISe**

Uses the internally generated noise signal.

**INTeRnal**

Uses the internally generated signal of LF1.

**EXTeRnal**

Uses an external LF signal (EXT1).

\*RST: LF1 <AM1>; LF2 <AM2>

**Example:** See [Example "Creating an amplitude modulated RF signal"](#) on page 544.

**Manual operation:** See ["Source"](#) on page 86

**[:SOURce<hw>]:AM<ch>[:DEPTH] <Depth>**

Sets the depth of the amplitude modulation in percent.

**Suffix:**

<ch> 1..2  
 Modulation signal channel

**Parameters:**

<Depth> float  
 Range: 0 to 100

**Example:** See [Example "Creating an amplitude modulated RF signal"](#) on page 544.

**[:SOURce<hw>]:AM<ch>:DEPTH:LINear <DepthLin>**

Sets the depth of the linear amplitude modulation in percent / volt.

**Parameters:**

<DepthLin> float  
 Range: 0 to 100  
 Increment: 0.1  
 \*RST: 30

**Example:** See [Example "Creating an amplitude modulated RF signal"](#) on page 544. Similar to DEPTH.

**Manual operation:** See ["Depth"](#) on page 91

**[ :SOURce<hw>]:AM<ch>:DEPTH:EXPOnential <DepthExp>**

Sets the depth of the exponential amplitude modulation in dB/volt.

**Parameters:**

<DepthExp> float  
 Range: 0 to 100  
 Increment: 0.01  
 \*RST: 10

**Example:** See [Example "Creating an amplitude modulated RF signal"](#) on page 544. Similar to DEPTH.

**Manual operation:** See ["Depth"](#) on page 91

**[ :SOURce<hw>]:AM:MODE <AmMode>**

Selects the mode of the amplitude modulation.

`[ :SOURce<hw>]:AM:MODE > SCAN` sets `[ :SOURce<hw>]:AM:TYPE > EXPOnential`.

For active external exponential AM, automatically sets `[ :SOURce<hw>]:INPut:MODext:COUPling<ch> > DC`.

**Parameters:**

<AmMode> SCAN | NORMAl  
 \*RST: NORMAl

**Example:** See [Example "Using an external signal source"](#) on page 545.

**Options:** R&S SMAB-K721

**Manual operation:** See ["Mode"](#) on page 90

**[ :SOURce<hw>]:AM:DEPTH:SUM <AmDepthSum>**

Sets the total depth of the LF signal when using combined signal sources in amplitude modulation.



**Parameters:**

<AmDepthSum> float  
 Range: 0 to 100  
 Increment: 0.1  
 \*RST: 30

**Example:** See [Example "Using combined LF signals"](#) on page 545.

**Manual operation:** See ["Total Depth"](#) on page 91

**[ :SOURce<hw>]:AM:DEVIation:MODE <AmDevMode>**

Selects the coupling mode. The coupling mode parameter also determines the mode for fixing the total depth.

**Parameters:**

<AmDevMode> UNCOupled | TOTal | RATIo

**UNCOupled**

Does not couple the LF signals.

The deviation depth values of both paths are independent.

**TOTal**

Couples the deviation depth of both paths.

**RATIo**

Couples the deviation depth ratio of both paths

\*RST: UNCOupled

**Example:** See [Example "Using combined LF signals"](#) on page 545.

**Manual operation:** See ["Deviation Mode"](#) on page 91

**[ :SOURce<hw>]:AM:RATIo <Ratio>**

Sets the deviation ratio (path#2 to path#1) in percent.

**Parameters:**

<Ratio> float  
 Range: 0 to 100  
 Increment: 0.1  
 \*RST: 100

**Example:** See [Example "Creating an amplitude modulated RF signal"](#) on page 544.

**Manual operation:** See ["Ratio Path2/Path1"](#) on page 92

**[ :SOURce<hw>]:AM<ch>:SENSitivity:EXPOntial <Sensitivity>**

For [ :SOURce<hw>]:AM:TYPEEXP, sets the sensitivity of the external signal source for amplitude modulation.

**Parameters:**

<Sensitivity> float  
 Range: 0 to 100  
 Increment: 0.01  
 \*RST: 10

**Example:** See [Example "Using an external signal source"](#) on page 545.

**Manual operation:** See ["Sensitivity"](#) on page 91

**[ :SOURce<hw>]:AM<ch>:SENSitivity[:LINear] <Sensitivity>**

For [ :SOURce<hw> ] :AM:TYPE LIN, sets the sensitivity of the external signal source for amplitude modulation.

**Parameters:**

<Sensitivity> float  
 Range: 0 to 100  
 Increment: 0.1  
 \*RST: 30

**Example:** See [Example "Using an external signal source"](#) on page 545.

**Manual operation:** See ["Sensitivity"](#) on page 91

**[ :SOURce<hw>]:AM:TYPE <AmType>**

Selects the type of amplitude modulation.

For [ :SOURce<hw> ] :AM:MODE SCAN, only EXPonential is available.

For active external exponential AM, automatically sets [ :SOURce<hw> ] :INPut :MODext:COUPling<ch>DC.

**Parameters:**

<AmType> LINear | EXPonential  
 \*RST: LINear

**Example:** See [Example "Using an external signal source"](#) on page 545.

**Options:** R&S SMAB-K721

**Manual operation:** See ["Type"](#) on page 90

### 14.16.1.3 SOURce:CHIRp Subsystem

Option: see [Chapter 5.1, "Required Options"](#), on page 80.

With the commands described in this section, you can configure the settings for chirp modulation, select the trigger mode and determine the parameters for an external pulse / trigger signal.

The following examples show some variants for generating the modulation chirp.

**Example: Perform chirp modulation**

Using the internal pulse generator, the following command sequence configures a chirp modulated RF signal.

```
// Reset the instrument to start from an initial state
*RST; *CLS

// Set the RF signal frequency and level
SOURce:FREQuency:CW 4000000000
SOURce:POWer:POWer: -25

// Configure the chirp modulation settings
// set the pulse parameters and the trigger mode
// query the compression ratio
// activate RF signal output

// Trigger a continuous chirp modulated signal
SOURce:CHIRp:TRIGger:MODE AUTO
SOURce:CHIRp:DIRection UP
SOURce:CHIRp:PULSe:PERiod 0.00001
SOURce:CHIRp:PULSe:WIDTh 0.000008
SOURce:CHIRp:BANDwidth 2000
SOURce:CHIRp:COMPression:RATio?
// Response: 0.01
SOURce:CHIRp:STATe 1
OUTPut1:STATe 1

// Trigger a single chirp modulation signal
SOURce:CHIRp:TRIGger:MODE SING
SOURce:CHIRp:DIRection DOWN
SOURce:CHIRp:PULSe:PERiod 0.00002
SOURce:CHIRp:PULSe:WIDTh 0.000002
SOURce:CHIRp:BANDwidth 5000
SOURce:CHIRp:STATe 1
SOURce:CHIRp:TRIGger:IMMediate

// Alternatively configure the chirp modulation settings
// using an external pulse signal.
// Select the trigger mode, set the polarity of the external signal,
// select the impedance of the external pulse signal input
SOURce:CHIRp:TRIGger:MODE EXT
SOURce:CHIRp:TRIGger:EXTernal:POLarity NORMal
SOURce:CHIRp:TRIGger:EXTernal:IMPEDance G10K
SOURce:CHIRp:STATe 1
```

The following commands are available:

<a href="#">[:SOURce&lt;hw&gt;]:CHIRp:BANDwidth</a> .....	552
<a href="#">[:SOURce&lt;hw&gt;]:CHIRp:COMPression:RATio?</a> .....	552
<a href="#">[:SOURce&lt;hw&gt;]:CHIRp:DIRection</a> .....	552
<a href="#">[:SOURce&lt;hw&gt;]:CHIRp:PULSe:PERiod</a> .....	552
<a href="#">[:SOURce&lt;hw&gt;]:CHIRp:PULSe:WIDTh</a> .....	553

<a href="#">[:SOURce&lt;hw&gt;]:CHIRp:STATe.....</a>	553
<a href="#">[:SOURce&lt;hw&gt;]:CHIRp:TRIGger:IMMediate.....</a>	553
<a href="#">[:SOURce&lt;hw&gt;]:CHIRp:TRIGger:MODE.....</a>	553

---

#### **[:SOURce<hw>]:CHIRp:BANDwidth <Bandwidth>**

Sets the modulation bandwidth of the chirp modulated signal.

##### **Parameters:**

<Bandwidth>	float
	Range: 0 to Depends on hardware variant
	Increment: 0.01
	*RST: 1E3

**Example:** See [Example "Perform chirp modulation"](#) on page 551.

**Manual operation:** See "[Bandwidth](#)" on page 95

---

#### **[:SOURce<hw>]:CHIRp:COMPression:RATio?**

Queries the pulse compression ratio (= product of pulse width (s) and bandwidth (Hz)).

##### **Return values:**

<Ratio>	float
	Range: 0 to 80E6
	Increment: 0.01

**Example:** See [Example "Perform chirp modulation"](#) on page 551.

**Usage:** Query only

**Manual operation:** See "[Compression Ratio](#)" on page 96

---

#### **[:SOURce<hw>]:CHIRp:DIRection <Direction>**

Selects the direction of the chirp modulation.

##### **Parameters:**

<Direction>	DOWN   UP
	*RST: UP

**Example:** See [Example "Perform chirp modulation"](#) on page 551.

**Manual operation:** See "[Direction](#)" on page 95

---

#### **[:SOURce<hw>]:CHIRp:PULSe:PERiod <Period>**

Sets the period of the generated modulation chirp. The period determines the repetition frequency of the internal signal.

**Parameters:**

<Period> float  
 Range: 5E-6 (2E-7 with K23) to 100  
 Increment: 1E-6  
 \*RST: 10E-6

**Example:** See [Example "Perform chirp modulation"](#) on page 551.

**Manual operation:** See "[Pulse Period](#)" on page 95

**[:SOURce<hw>]:CHIRp:PULSe:WIDTh <Width>**

Sets the width of the generated pulse. The pulse width must be at least 1us less than the set pulse period.

**Parameters:**

<Width> float  
 Range: 2E-6 (1E-7 with K23) to 100  
 Increment: 1E-6  
 \*RST: 2E-6

**Example:** See [Example "Perform chirp modulation"](#) on page 551.

**Manual operation:** See "[Pulse Width](#)" on page 96

**[:SOURce<hw>]:CHIRp:STATe <State>**

Activates the generation of a chirp modulation signal.

**Parameters:**

<State> 0 | 1 | OFF | ON  
 \*RST: 0

**Example:** See [Example "Perform chirp modulation"](#) on page 551.

**Manual operation:** See "[State](#)" on page 94

**[:SOURce<hw>]:CHIRp:TRIGger:IMMEDIATE**

Immediately starts the chirp signal generation.

**Example:** See [Example "Perform chirp modulation"](#) on page 551.

**Usage:** Event

**Manual operation:** See "[Execute Single Trigger](#)" on page 96

**[:SOURce<hw>]:CHIRp:TRIGger:MODE <Mode>**

Selects the trigger mode for the chirp modulation signal.

**Parameters:**

<Mode> AUTO | EXTeRnal | EGATe | SINGle | ESINgle  
 \*RST: AUTO

**Example:** See [Example "Perform chirp modulation"](#) on page 551.

**Manual operation:** See "[Trigger Mode](#)" on page 96

**14.16.1.4 SOURce:FM Subsystem**

Option: R&S SMAB-K720

The FM subsystem contains the commands for setting the frequency modulation.

**Example: Creating a frequency modulated RF signal**

Using the internal LF generator, the following command sequence configures a frequency modulated signal.

```
// Reset the instrument to start from a defined state
*RST

// Set RF frequency and amplitude
SOURcel:FREQuency:CW 6000000000
SOURcel:POWer:LEVel:IMMediate:AMPLitude -25

// Configure the modulation signal
SOURcel:LFOutput1:SHAPE SINE
SOURcel:LFOutput1:FREQuency 20000

// Configure the frequency modulation settings and switch FM on
SOURcel:FM1:SOURce LF1
SOURcel:FM1:DEVIation 1000
SOURcel:FM:RATio 40
SOURcel:FM:MODE LNOise
SOURcel:FM1:STATe 1

// Switch on LF and RF signal output
SOURcel:LFOutput1:STATe 1
OUTPut1:STATe 1
```

**Example: Using combined LF signals**

Using the internal LF generators of both paths, the following command sequences configure a frequency modulated signal with determined deviations.

```
// Configure the FM modulation settings with combined LF signal sources
SOURcel:FM1:SOURce LF1
SOURcel:FM1:DEVIation 1000
// Select the modulation signal source for the second path
SOURcel:FM2:SOURce LF2
// Combine the signals of both paths with fixed total deviation depth
```

```

SOURcel:FM1:DEVIation:MODE TOT
SOURcel:FM1:DEVIation:SUM 5000

// Query the deviation depth of modulation signal in the second path
SOURcel:FM2:DEVIation?
// Response: 4000

// Combine the signals of both paths with fixed ratio
SOURcel:FM1:DEVIation:MODE RAT
SOURcel:FM1:RATio 100
SOURcel:FM2:DEVIation 10000

// Query the deviation depth of modulation signal in the first path
SOURcel:AM1:DEVIation?
// Response: 1000

SOURcel:FM1:STATe 1
SOURcel:FM2:STATe 1

```

### Example: Using an external signal source

Alternatively configure the frequency modulation settings with an external modulation signal.

```

// Reset the instrument to start from a defined state
*RST

// Set RF frequency and amplitude
SOURcel:FREQuency:CW 6000000000
SOURcel:POWer:LEVel:IMMediate:AMPLitude -25

// Configure the frequency modulation settings and switch FM on
SOURcel:FM1:SOURce EXT1
SOURcel:FM1:DEVIation 5000

// Query the input sensitivity at the external modulation input
:SOURCe1:FM1:SENSitivity?
// Response: 1000
// since the voltage value for full modulation is 1V,
// the resulting sensitivity is precisely 5000 Hz/V.

// Switch on FM and RF signal output
SOURcel:FM1:STATe 1
OUTPut1:STATe 1

```

The following commands are available:

<a href="#">[:SOURce&lt;hw&gt;]:FM&lt;ch&gt;:STATe</a> .....	556
<a href="#">[:SOURce&lt;hw&gt;]:FM&lt;ch&gt;[:DEVIation]</a> .....	556
<a href="#">[:SOURce&lt;hw&gt;]:FM&lt;ch&gt;:SOURce</a> .....	556
<a href="#">[:SOURce&lt;hw&gt;]:FM:DEVIation:MODE</a> .....	557
<a href="#">[:SOURce&lt;hw&gt;]:FM:DEVIation:SUM</a> .....	557

<a href="#">[:SOURce&lt;hw&gt;]:FM:RATIo.....</a>	<a href="#">558</a>
<a href="#">[:SOURce&lt;hw&gt;]:FM:MODE.....</a>	<a href="#">558</a>
<a href="#">[:SOURce&lt;hw&gt;]:FM:SENSitivity?.....</a>	<a href="#">558</a>

---

#### **[:SOURce<hw>]:FM<ch>:STATe <State>**

Activates frequency modulation.

##### **Suffix:**

FM<ch>                    1..2  
determines the modulation signal channel.

##### **Parameters:**

<State>                    0 | 1 | OFF | ON  
\*RST:                    0

**Example:**                See [Example "Creating a frequency modulated RF signal"](#)  
on page 554.

**Manual operation:**    See ["State"](#) on page 86

---

#### **[:SOURce<hw>]:FM<ch>[:DEViation] <Deviation>**

Sets the modulation deviation of the frequency modulation in Hz.

##### **Suffix:**

FM<ch>                    1|2  
Modulation signal channel

##### **Parameters:**

<Deviation>                float  
The maximum deviation depends on the RF frequency and the  
selected modulation mode (see data sheet).  
Range:                    0 to max  
Increment:                0.01  
\*RST:                    1E3

**Example:**                See [Example "Creating a frequency modulated RF signal"](#)  
on page 554.

**Manual operation:**    See ["Deviation"](#) on page 86

---

#### **[:SOURce<hw>]:FM<ch>:SOURce <Source>**

Selects the modulation source for frequency modulation.

##### **Suffix:**

FM<ch>                    1|2  
Modulation signal channel.

##### **Parameters:**

<Source>                    LF1 | LF2 | NOISe | EXT1 | INTernal | EXTernal | EXT2



**LF1|LF2**

Uses an internally generated LF signal.

**INTernal = LF1**

Works like `LF1`

**EXTernal**

Works like `EXT1`

**EXT1|EXT2**

Uses an externally supplied LF signal.

**NOISe**

Uses the internally generated noise signal.

\*RST:        LF1 <FM1>; LF2 <FM2>

**Example:** See [Example "Creating a frequency modulated RF signal"](#) on page 554.

**Manual operation:** See ["Source"](#) on page 86

**[[:SOURce<hw>]:FM:DEVIation:MODE <FmDevMode>**

Selects the coupling mode. The coupling mode parameter also determines the mode for fixing the total deviation.

**Parameters:**

<FmDevMode>        UNCOupled | TOTal | RATio

**UNCOupled**

Does not couple the LF signals.

The deviation values of both paths are independent.

**TOTal**

Couples the deviation of both paths.

**RATio**

Couples the deviation ratio of both paths

\*RST:        UNCOupled

**Example:** See [Example "Using combined LF signals"](#) on page 554.

**Manual operation:** See ["Deviation Mode"](#) on page 87

**[[:SOURce<hw>]:FM:DEVIation:SUM <FmDevSum>**

Sets the total deviation of the LF signal when using combined signal sources in frequency modulation.

**Parameters:**

<FmDevSum>        float  
 Range:        0 to 40E6  
 Increment:    0.01  
 \*RST:        1E3

**Example:** See [Example "Using combined LF signals"](#) on page 554.

**Manual operation:** See ["Total Deviation"](#) on page 87

**[:SOURce<hw>]:FM:RATio <Ratio>**

Sets the deviation ratio (path2 to path1) in percent.

**Parameters:**

<Ratio> float  
 Range: 0 to 100  
 Increment: 0.1  
 \*RST: 100

**Example:** See [Example "Creating a frequency modulated RF signal"](#) on page 554.

**Manual operation:** See ["Ratio Path2/Path1"](#) on page 87

**[:SOURce<hw>]:FM:MODE <Mode>**

Selects the mode for the frequency modulation.

**Parameters:**

<Mode> HBANdwidth | LNOise  
**HBANdwidth**  
 Selects maximum range for modulation bandwidth.  
**LNOise**  
 Selects optimized phase noise and spurious characteristics with reduced modulation bandwidth and FM deviation.  
 \*RST: HBANdwidth

**Example:** See [Example "Creating a frequency modulated RF signal"](#) on page 554.

**Manual operation:** See ["Mode"](#) on page 87

**[:SOURce<hw>]:FM:SENSitivity?**

Queries the sensitivity of the externally supplied signal for frequency modulation. The sensitivity depends on the set modulation deviation.

**Return values:**

<Sensitivity> float  
 Sensitivity in Hz/V.  
 It is assigned to the voltage value for full modulation of the input.  
 Range: 0 to max  
 Increment: 0.01

**Example:** See [Example "Using an external signal source"](#) on page 555.

**Usage:** Query only

### 14.16.1.5 SOURce:PM Subsystem

Option: R&S SMAB-K720

The PM subsystem contains the commands for setting the phase modulation. You can configure the internal modulation source (LF generator) with the commands listed in [Chapter 14.16.6, "SOURce:LFOutput Subsystem"](#), on page 632 .

#### Example: Performing phase modulation

The following example shows a command sequence to perform phase modulation.

```
// Reset the instrument to start from an initial state
*RST; *CLS

// Set the RF signal frequency and level
SOURce:FREQuency:CW 4000000000
SOURce:POWer:LEVel:IMMediate:AMPLitude -25

// Configure the phase modulation settings
SOURcel:LFOutput1:SHAPE SINE
SOURcel:LFOutput1:FREQuency 1000

// Select the LF signal generated by the internal modulation generator
// or the internally generated noise signal
SOURcel:PM1:DEVIation 1
SOURcel:PM1:SOURce LF1
// SOURcel:PM1:SOURce INTernal
// SOURcel:PM1:SOURce NOISe
SOURcel:PM1:RATio 40
SOURcel:PM1:MODE HBAN

// Alternatively configure the phase modulation settings for an
// external modulation source and query the input sensitivity.
SOURcel:PM1:SOURce EXT1
// SOURcel:PM1:SOURce EXTernal
SOURcel:PM1:DEVIation 1
SOURcel:PM1:SENSitivity?
// Response: 1
// since the voltage value for full modulation is 1V,
// the resulting sensitivity is precisely 1RAD/V.

// Activate the signal output
SOURcel:PM1:STATe 1
OUTPut1:STATe 1
```

#### Example: Using combined LF signals

Using the internal LF generators of both paths, the following command sequences configure an phase modulated signal with determined deviations.

```

// Configure the Phase modulation settings with combined LF signal sources
SOURce1:PM1:SOURce LF1
SOURce1:PM1:DEVIation 1.5
// Select the modulation signal source for the second path
SOURce1:PM2:SOURce LF2
// Combine the signals of both paths with fixed total deviation depth
SOURce1:PM1:DEVIation:MODE TOT
SOURce1:PM1:DEVIation:SUM 2

// Query the deviation depth of the modulation signal in the second path
SOURce1:PM2:DEVIation?
// Response: 0.5

// Combine the signals of both paths with fixed ratio
SOURce1:PM1:DEVIation:MODE RAT
SOURce1:PM1:RATio 80
SOURce1:PM2:DEVIation?
// Response: 1.2

// Query the deviation depth of modulation signal in the first path
SOURce1:PM1:DEVIation?
// Response: 1.5

SOURce1:FM1:STATe 1
SOURce1:FM2:STATe 1

```

The following commands are available:

<a href="#">[:SOURce&lt;hw&gt;]:PM&lt;ch&gt;:STATe</a> .....	560
<a href="#">[:SOURce&lt;hw&gt;]:PM&lt;ch&gt;:SOURce</a> .....	561
<a href="#">[:SOURce&lt;hw&gt;]:PM:MODE</a> .....	561
<a href="#">[:SOURce&lt;hw&gt;]:PM:DEVIation:MODE</a> .....	562
<a href="#">[:SOURce&lt;hw&gt;]:PM:DEVIation:SUM</a> .....	562
<a href="#">[:SOURce&lt;hw&gt;]:PM:RATio</a> .....	562
<a href="#">[:SOURce&lt;hw&gt;]:PM:SENSitivity?</a> .....	562
<a href="#">[:SOURce]:PM&lt;ch&gt;[:DEVIation]</a> .....	563

---

#### **[\[:SOURce<hw>\]:PM<ch>:STATe <State>](#)**

Activates phase modulation.

Activation of phase modulation deactivates frequency modulation.

#### **Suffix:**

PM<ch>                    1|2  
                              Sets the modulation signal channel.

#### **Parameters:**

<State>                    0 | 1 | OFF | ON  
                              \*RST:            0

**Example:**                See [Example "Performing phase modulation"](#) on page 559.

**Manual operation:** See ["State"](#) on page 86

---

**[:SOURce<hw>]:PM<ch>:SOURce <Source>**

Selects the modulation source for phase modulation signal.

**Suffix:**

PM<ch>                    1|2  
Sets the modulation signal channel.

**Parameters:**

<Source>                    LF1 | LF2 | NOISe | EXT1 | EXT2 | INTernal | EXTernal

**LF1|LF2**

Uses an internally generated LF signal.

**EXT1|EXT2**

Uses an externally supplied LF signal.

**NOISe**

Uses the internally generated noise signal.

**INTernal**

Uses the internally generated signal of LF1.

**EXTernal**

Uses an external LF signal (EXT1).

\*RST:                    LF1 <PM1>; LF2 <PM2>

**Example:** See [Example "Performing phase modulation"](#) on page 559.

**Manual operation:** See ["Source"](#) on page 86

---

**[:SOURce<hw>]:PM:MODE <Mode>**

Selects the mode for the phase modulation.

**Parameters:**

<Mode>                    HBANdwidth | HDEViation | LNOise

**HBANdwidth**

Sets the maximum available bandwidth.

**HDEViation**

Sets the maximum range for  $\Phi$ M deviation.

**LNOise**

Selects a phase modulation mode with phase noise and spurious characteristics close to CW mode.

\*RST:                    HBANdwidth

**Example:** See [Example "Performing phase modulation"](#) on page 559.

**Manual operation:** See ["Mode"](#) on page 89

---

**[[:SOURce<hw>]:PM:DEVIation:MODE <PmDevMode>**

Selects the coupling mode. The coupling mode parameter also determines the mode for fixing the total deviation.

**Parameters:**

<PmDevMode>      UNCOupled | TOTal | RATio

**UNCOupled**

Does not couple the LF signals.

The deviation values of both paths are independent.

**TOTal**

Couples the deviation of both paths.

**RATio**

Couples the deviation ratio of both paths

\*RST:            UNCOupled

**Example:**            See [Example "Using combined LF signals"](#) on page 559

**Manual operation:**    See ["Deviation Mode"](#) on page 88

---

**[[:SOURce<hw>]:PM:DEVIation:SUM <PmDevSum>**

Sets the total deviation of the LF signal when using combined signal sources in phase modulation.

**Parameters:**

<PmDevSum>      float  
                          Range:      0 to 20  
                          Increment: 1E-6  
                          \*RST:      1

**Example:**            See [Example "Using combined LF signals"](#) on page 559

**Manual operation:**    See ["Total Deviation"](#) on page 88

---

**[[:SOURce<hw>]:PM:RATio <Ratio>**

Sets the deviation ratio (path2 to path1) in percent.

**Parameters:**

<Ratio>            float  
                          Range:      0 to 100  
                          Increment: 0.01  
                          \*RST:      100

**Example:**            See [Example "Performing phase modulation"](#) on page 559.

**Manual operation:**    See ["Ratio Path2/Path1"](#) on page 89

---

**[[:SOURce<hw>]:PM:SENSitivity?**

Queries the sensitivity of the externally applied signal for phase modulation.

The returned value reports the sensitivity in RAD/V. It is assigned to the voltage value for full modulation of the input.

**Return values:**

<Sensitivity> float

**Example:** See [Example "Performing phase modulation"](#) on page 559.

**Usage:** Query only

**[:SOURce]:PM<ch>[:DEVIation] <Deviation>**

Sets the modulation deviation of the phase modulation in RAD.

**Parameters:**

<Deviation> float

The maximal deviation depends on the RF frequency and the selected modulation mode (see data sheet).

Range: 0 to max

Increment: 1

\*RST: 1

Default unit: RAD

**Example:** See [Example "Performing phase modulation"](#) on page 559.

**Manual operation:** See ["Deviation"](#) on page 88

#### 14.16.1.6 SOURce:PULM Subsystem

Option: see [Chapter 5.1, "Required Options"](#), on page 80.

The PULM subsystem contains the commands for setting the pulse modulation.

- [Pulse Modulation Settings](#).....563
- [Pulse Train Settings](#)..... 569
- [Pulse Train Data Exchange](#)..... 571

#### Pulse Modulation Settings

With the commands described in this section, you can configure the settings for pulse modulation, select the trigger mode and determine delay times for the pulse modulation signal.

**Example: Perform pulse modulation**

The example shows a command sequence to perform pulse modulation.

```
// Reset the instrument to start from an initial state
*RST; *CLS

// Set the RF signal frequency and level
SOURce:FREQuency:CW 4000000000
SOURce:POWer:LEVel:IMMediate:AMPLitude -25
```

```

// Configure the pulse modulation settings
// Select the internal modulation generator,
// set trigger mode, select pulse mode, transition type

// Trigger a single pulse

SOURce:PULM:SOURce INT
SOURce:PULM:TRIGger:MODE SING
SOURce:PULM:MODE DOUB
SOURce:PULM:TTYPe SMO

SOURce:PULM:TRIG:IMM

// Alternatively configure the pulse modulation settings for
// external modulation source
// Select the source, set the polarity of the external signal,
// select the impedance for the external pulse modulation input/
// for the external pulse modulation trigger input
SOURce:PULM:SOURce EXT
SOURce:PULM:POLarity NORMal
SOURce:PULM:IMPedance G1K

// Configure the pulse generator settings
// Set pulse period, width, and delay
SOURce:PULM:PERiod 10 us
SOURce:PULM:WIDTH 8 us
SOURce:PULM:DOUBle:WIDTH 0.0000012
SOURce:PULM:DOUBle:DELay 0.0000045

// Activate the signal output
SOURce:PGENERator:OUTPut:STATe 1
SOURce:PULM:STATe 1
OUTPut1:STATe 1

```

The following commands are available:

<a href="#">[:SOURce&lt;hw&gt;]:PULM:MODE</a> .....	565
<a href="#">[:SOURce&lt;hw&gt;]:PULM:TRIGger:MODE</a> .....	565
<a href="#">[:SOURce]:PULM[:INTernal][:TRAIIn]:TRIGger:IMMEDIATE</a> .....	565
<a href="#">[:SOURce&lt;hw&gt;]:PULM:PERiod</a> .....	565
<a href="#">[:SOURce&lt;hw&gt;]:PULM:WIDTH</a> .....	566
<a href="#">[:SOURce&lt;hw&gt;]:PULM:DELay</a> .....	566
<a href="#">[:SOURce&lt;hw&gt;]:PULM:DOUBle:DELay</a> .....	566
<a href="#">[:SOURce&lt;hw&gt;]:PULM:DOUBle:WIDTH</a> .....	567
<a href="#">[:SOURce&lt;hw&gt;]:PULM:DOUBle:STATe</a> .....	567
<a href="#">[:SOURce&lt;hw&gt;]:PULM:STATe</a> .....	567
<a href="#">[:SOURce&lt;hw&gt;]:PULM:SOURce</a> .....	567
<a href="#">[:SOURce&lt;hw&gt;]:PULM:TTYPe</a> .....	567
<a href="#">[:SOURce&lt;hw&gt;]:PULM:POLarity</a> .....	568
<a href="#">[:SOURce&lt;hw&gt;]:PULM:IMPedance</a> .....	568
<a href="#">[:SOURce&lt;hw&gt;]:PULM:THReshold</a> .....	568



---

**[ :SOURce<hw>]:PULM:MODE <Mode>**

Selects the mode for the pulse modulation.

**Parameters:**

<Mode>                    SINGle | DOUBle | PTRain

**SINGle**  
Generates a single pulse.

**DOUBle**  
Generates two pulses within one pulse period.

**PTRain**  
Generates a user-defined pulse train.  
Specify the pulse sequence with the commands:  
`[ :SOURce<hw> ] :PULM:TRAIIn:ONTime`  
`[ :SOURce<hw> ] :PULM:TRAIIn:OFFTime`  
`[ :SOURce<hw> ] :PULM:TRAIIn:REPetition`

\*RST:            SINGle

**Example:**            See [Example "Perform pulse modulation"](#) on page 563.

**Options:**            PTRain requires R&S SMAB-K27

**Manual operation:** See ["Pulse Mode"](#) on page 99

---

**[ :SOURce<hw>]:PULM:TRIGger:MODE <Mode>**

Selects a trigger mode - auto, single, external, external single or external gated - for generating the modulation signal.

**Parameters:**

<Mode>                    AUTO | EXTErnal | EGATe | SINGle | ESINGle

\*RST:            AUTO

**Example:**            See [Example "Perform pulse modulation"](#) on page 563.

**Manual operation:** See ["Trigger Mode"](#) on page 100

---

**[ :SOURce]:PULM[:INTernal][:TRAIIn]:TRIGger:IMMEDIATE**

If `[ :SOURce<hw> ] :PULM:TRIGger:MODESINGle`, triggers the pulse generator.

**Example:**            See [Example "Perform pulse modulation"](#) on page 563.

**Manual operation:** See ["Execute Single Trigger"](#) on page 103

---

**[ :SOURce<hw>]:PULM:PERiod <Period>**

Sets the period of the generated pulse, that means the repetition frequency of the internally generated modulation signal.

**Parameters:**

<Period> float  
 The minimum value depends on the installed options  
 R&S SMAB-K22 or R&S SMAB-K23  
 Range: 20E-9 to 100  
 Increment: 5E-9  
 \*RST: 10E-6

**Example:** See [Example "Perform pulse modulation"](#) on page 563.

**Manual operation:** See ["Pulse Period"](#) on page 102

**[:SOURce<hw>]:PULM:WIDTh <Width>**

Sets the width of the generated pulse, that means the pulse length. It must be at least 20ns less than the set pulse period.

**Parameters:**

<Width> float  
 Range: 20E-9 to 100  
 Increment: 10E-9  
 \*RST: 2E-6

**Example:** See [Example "Perform pulse modulation"](#) on page 563.

**Manual operation:** See ["Pulse Width"](#) on page 102

**[:SOURce<hw>]:PULM:DELay <Delay>**

Sets the pulse delay.

**Parameters:**

<Delay> float  
 \*RST: 1ms

**Example:** See [Example "Perform pulse modulation"](#) on page 563.

**Manual operation:** See ["Pulse Delay"](#) on page 103

**[:SOURce<hw>]:PULM:DOUBLE:DELay <Delay>**

Sets the delay from the start of the first pulse to the start of the second pulse.

**Parameters:**

<Delay> float  
 \*RST: 1E-6

**Example:** See [Example "Perform pulse modulation"](#) on page 563.

**Manual operation:** See ["Double Pulse Delay"](#) on page 103

---

**[:SOURce<hw>]:PULM:DOUBLE:WIDTH <Width>**

Sets the width of the second pulse.

**Parameters:**

<Width> float  
Increment: 5E-9

**Example:** See [Example "Perform pulse modulation"](#) on page 563.

**Manual operation:** See ["Double Pulse Width"](#) on page 103

---

**[:SOURce<hw>]:PULM:DOUBLE:STATE <State>**

Provided for backward compatibility with former Rohde & Schwarz signal generators.

Works like the command `[ :SOURce<hw> ] :PULM:MODEDOUBLE`.

**Parameters:**

<State> 0 | 1 | OFF | ON  
\*RST: 0

---

**[:SOURce<hw>]:PULM:STATE <State>**

Activates pulse modulation.

**Parameters:**

<State> 0 | 1 | OFF | ON  
\*RST: 0

**Example:** See [Example "Perform pulse modulation"](#) on page 563.

**Manual operation:** See ["State"](#) on page 84

---

**[:SOURce<hw>]:PULM:SOURce <Source>**

Selects between the internal (pulse generator) or an external pulse signal for the modulation.

**Parameters:**

<Source> INTERNAL | EXTERNAL  
\*RST: INTERNAL

**Example:** See [Example "Perform pulse modulation"](#) on page 563.

**Manual operation:** See ["Source"](#) on page 84

---

**[:SOURce<hw>]:PULM:TTYPe <Source>**

Sets the transition mode for the pulse signal.

**Parameters:**

<Source> SMOOthed | FAST

**SMOothed**

flattens the slew rate, resulting in longer rise/fall times.

**FAST**

enables fast transitions with shortest rise and fall times.

\*RST: FAST

**Example:** See [Example "Perform pulse modulation"](#) on page 563.

**Manual operation:** See ["Transition Type"](#) on page 84

**[[:SOURce<hw>]:PULM:POLarity <Polarity>**

Sets the polarity of the externally applied modulation signal.

**Parameters:**

<Polarity> NORMal | INVerted

**NORMal**

Suppresses the RF signal during the pulse pause.

**INVerted**

Suppresses the RF signal during the pulse.

\*RST: NORMal

**Example:** See [Example "Perform pulse modulation"](#) on page 563.

**Manual operation:** See ["Polarity"](#) on page 111

**[[:SOURce<hw>]:PULM:IMPedance <Impedance>**

Sets the impedance for the external pulse trigger and pulse modulation input.

**Parameters:**

<Impedance> G50 | G10K

\*RST: G50

**Example:** See [Example "Perform pulse modulation"](#) on page 563.

**Manual operation:** See ["Impedance"](#) on page 111

**[[:SOURce<hw>]:PULM:THReshold <Threshold>**

Sets the threshold for the input signal at the [Pulse Ext] connector.

**Parameters:**

<Threshold> float

Range: 0 to 2

Increment: 0.1

\*RST: 1

Default unit: V

**Example:** SOURce:PULM:THReshold 1

**Manual operation:** See ["Threshold"](#) on page 111

## Pulse Train Settings

Option: R&S SMAB-K27

This section describes the commands for the pulse train modulation and the associated file handling. For background information, see [Chapter 5.4.4.2, "Pulse Generator > Pulse Train Settings"](#), on page 103.

### Example: Generating a pulse train signal

The following settings are required to perform pulse train modulation.



Always create and select pulse train data list first before you activate the pulse train mode.

Otherwise, an error is displayed

```
*RST; *CLS

// Set the RF signal frequency and level
SOURCE:FREQUENCY: CW 4000000000
SOURCE:POWER:LEVEL:IMMEDIATE:AMPLITUDE -25

// Create a pulse train data list
// Select the directory
MMEM:CDIR '/var/user/'
SOURCE1:PULM:TRAIN:CATALOG?
// my_pt
// Create and/or select the pulse train data file
SOURCE1:PULM:TRAIN:SELECT "/var/user/pt"
// Enter the pulse train data
SOURCE:PULM:TRAIN:ONTIME 0.0001,0.00025,0.0001
SOURCE:PULM:TRAIN:OFFTIME 500us,500us,300us
SOURCE:PULM:TRAIN:REPETITION 2,0,3
// the second pulse is ignored

// Select pulse train mode
// Select the internal modulation generator and the pulse mode
SOURCE1:PULM:SOURCE INT
SOURCE1:PULM:MODE PTR
SOURCE1:PULM:TRIGGER:MODE EXT
SOURCE1:PGENERATOR:OUTPUT:STATE 1
SOURCE1:PGENERATOR:OUTPUT:POLARITY NORM
SOURCE:PGENERATOR:OUTPUT:STATE 1
SOURCE:PULM:STATE 1
OUTPUT1:STATE 1

// SOURCE1:PULM:TRAIN:CATALOG?
// my_pt, pt
// SOURCE1:PULM:TRAIN:DEL "/var/user/my_pt"
```

The following commands are available:

<code>[:SOURce&lt;hw&gt;]:PULM:TRAI:n:CATalog?</code> .....	570
<code>[:SOURce&lt;hw&gt;]:PULM:TRAI:n:DELeTe</code> .....	570
<code>[:SOURce&lt;hw&gt;]:PULM:TRAI:n:ONTime</code> .....	570
<code>[:SOURce&lt;hw&gt;]:PULM:TRAI:n:OFFTime</code> .....	570
<code>[:SOURce&lt;hw&gt;]:PULM:TRAI:n:REPetition:POINts?</code> .....	571
<code>[:SOURce&lt;hw&gt;]:PULM:TRAI:n:ONTime:POINts?</code> .....	571
<code>[:SOURce&lt;hw&gt;]:PULM:TRAI:n:OFFTime:POINts?</code> .....	571
<code>[:SOURce&lt;hw&gt;]:PULM:TRAI:n:REPetition</code> .....	571
<code>[:SOURce&lt;hw&gt;]:PULM:TRAI:n:SELeCt</code> .....	571

---

### `[:SOURce<hw>]:PULM:TRAI:n:CATalog?`

Queries the available pulse train files in the specified directory.

#### Return values:

<Catalog>                    string  
                                   List of list filenames, separated by commas

**Example:**                    See [Example "Generating a pulse train signal"](#) on page 569.

**Usage:**                        Query only

**Manual operation:**    See ["Pulse Train Data"](#) on page 105

---

### `[:SOURce<hw>]:PULM:TRAI:n:DELeTe <Filename>`

Deletes the specified pulse train file.

#### Setting parameters:

<Filename>                    string  
                                   Filename or complete file path; file extension is optional.

**Example:**                    See [Example "Generating a pulse train signal"](#) on page 569.

**Usage:**                        Setting only

**Manual operation:**    See ["Pulse Train Data"](#) on page 105

---

### `[:SOURce<hw>]:PULM:TRAI:n:ONTime <OnTime>`

### `[:SOURce<hw>]:PULM:TRAI:n:OFFTime <OffTime>`

Enters the pulse on/off times values in the selected list.

#### Parameters:

<OffTime>                    Offtime#1{, Offtime#2, ...} | binary block data  
                                   List of comma-separated numeric values or binary block data,  
                                   where:  
                                   The list of numbers can be of any length.  
                                   In binary block format, 8 (4) bytes are always interpreted as a  
                                   floating-point number with double accuracy.  
                                   See [:FORMat \[ :DATA\]](#) on page 468 for details.  
                                   The maximum length is 2047 values.  
                                   Range:            0 ns to 5 ms

**Example:** See [Example "Generating a pulse train signal"](#) on page 569.

**Manual operation:** See ["Edit Pulse Train Data"](#) on page 106

**[[:SOURce<hw>]:PULM:TRAI:REPetition:POINts?**

**[[:SOURce<hw>]:PULM:TRAI:ONTime:POINts?**

**[[:SOURce<hw>]:PULM:TRAI:OFFTime:POINts?**

Queries the number of on and off time entries and repetitions in the selected list.

**Return values:**

<Points> integer  
 Range: 0 to INT\_MAX  
 \*RST: 0

**Example:** See [Example "Generating a pulse train signal"](#) on page 569.

**Usage:** Query only

**[[:SOURce<hw>]:PULM:TRAI:REPetition <Repetition>**

Sets the number of repetitions for each pulse on/off time value pair.

**Parameters:**

<Repetition> Repetition#1{, Repetition#2, ...}  
 0 = ignore value pair  
 Set "Repetition = 0" to skip a particular pulse without deleting the pulse on/off time value pair  
 Range: 0 to 65535

**Example:** See [Example "Generating a pulse train signal"](#) on page 569.

**Manual operation:** See ["Edit Pulse Train Data"](#) on page 106

**[[:SOURce<hw>]:PULM:TRAI:SELEct <Filename>**

Selects or creates a data list in pulse train mode.

If the list with the selected name does not exist, a new list is created.

**Parameters:**

<Filename> string  
 Filename or complete file path; file extension can be omitted.

**Example:** See [Example "Generating a pulse train signal"](#) on page 569.

**Manual operation:** See ["Pulse Train Data"](#) on page 105

### Pulse Train Data Exchange

Option: R&S SMAB-K27

With the following commands, you can configure pulse trains in ASCII format and export or import them accordingly.

```

SOURCE1:PULM:SOURCE INT
SOURCE1:PULM:MODE PTR
SOURCE1:PULM:TRAIN:SElect "/var/user/pt"
SOURCE1:PULM:STATE 1

SOURCE1:PULM:TRAIN:DEXChange:MODE EXP
SOURCE1:PULM:TRAIN:DEXChange:AFILe:EXTension TXT
SOURCE1:PULM:TRAIN:DEXChange:AFILe:SEParator:DECimal DOT
SOURCE1:PULM:TRAIN:DEXChange:AFILe:SEParator:COLumn SEM
SOURCE1:PULM:TRAIN:DEXChange:AFILe:SEParator:COLumn COMM
SOURCE1:PULM:TRAIN:DEXChange:SElect "/var/user/pt.pulstrn"
SOURCE1:PULM:TRAIN:DEXChange:AFILe:SElect "/var/user/pt_script.txt"
SOURCE1:PULM:TRAIN:DEXChange:EXECute

```

The following commands are available:

<a href="#">[:SOURCE&lt;hw&gt;]:PULM:TRAIN:DEXChange:MODE.....</a>	572
<a href="#">[:SOURCE&lt;hw&gt;]:PULM:TRAIN:DEXChange:AFILe:EXTension.....</a>	572
<a href="#">[:SOURCE&lt;hw&gt;]:PULM:TRAIN:DEXChange:AFILe:SEParator:DECimal.....</a>	573
<a href="#">[:SOURCE&lt;hw&gt;]:PULM:TRAIN:DEXChange:AFILe:SEParator:COLumn.....</a>	573
<a href="#">[:SOURCE&lt;hw&gt;]:PULM:TRAIN:DEXChange:AFILe:CATalog?.....</a>	573
<a href="#">[:SOURCE&lt;hw&gt;]:PULM:TRAIN:DEXChange:AFILe:SElect.....</a>	573
<a href="#">[:SOURCE&lt;hw&gt;]:PULM:TRAIN:DEXChange:SElect.....</a>	574
<a href="#">[:SOURCE&lt;hw&gt;]:PULM:TRAIN:DEXChange:EXECute.....</a>	574

---

#### **[:SOURCE<hw>]:PULM:TRAIN:DEXChange:MODE <Mode>**

Determines the import or export of a list.

Specify the source or destination file with the command `[ :SOURCE<hw> ] :PULM:TRAIN:DEXChange:SElect`.

#### **Parameters:**

<Mode>                   IMPort | EXPort  
                           \*RST:       IMPort

**Example:**               See "Pulse Train Data Exchange" on page 571.

**Manual operation:**    See " Mode " on page 108

---

#### **[:SOURCE<hw>]:PULM:TRAIN:DEXChange:AFILe:EXTension <Extension>**

Determines the extension of the ASCII file for import or export, or to query existing files.

#### **Parameters:**

<Extension>               TXT | CSV  
                           \*RST:       TXT

**Example:**               See "Pulse Train Data Exchange" on page 571.

**Manual operation:**    See "ASCII File Settings" on page 108



---

**[:SOURce<hw>]:PULM:TRAI:n:DEXChange:AFILe:SEParator:DECimal <Decimal>**

Sets "." (decimal point) or "," (comma) as the decimal separator used in the ASCII data with floating-point numerals.

**Parameters:**

<Decimal>            DOT | COMMa  
 \*RST:            DOT

**Example:**            See ["Pulse Train Data Exchange"](#) on page 571.

**Manual operation:** See ["ASCII File Settings"](#) on page 108

---

**[:SOURce<hw>]:PULM:TRAI:n:DEXChange:AFILe:SEParator:COLumn <Column>**

Selects the separator between the frequency and level column of the ASCII table.

**Parameters:**

<Column>            TABulator | SEMicolon | COMMa | SPACe  
 \*RST:            COMMa

**Example:**            See ["Pulse Train Data Exchange"](#) on page 571.

**Manual operation:** See ["ASCII File Settings"](#) on page 108

---

**[:SOURce<hw>]:PULM:TRAI:n:DEXChange:AFILe:CATalog?**

Queries the available ASCII files in the current or specified directory.

**Return values:**

<Catalog>            string  
 List of ASCII files \*.txt or \*.csv, separated by commas.

**Example:**            See ["Pulse Train Data Exchange"](#) on page 571.

**Usage:**            Query only

**Manual operation:** See ["Select \(ASCII\) Source/Select \(ASCII\) Destination"](#) on page 109

---

**[:SOURce<hw>]:PULM:TRAI:n:DEXChange:AFILe:SElect <Filename>**

Selects the ASCII file to be imported or exported.

**Parameters:**

<Filename>            string  
 Filename or complete file path; file extension can be omitted.

**Example:**            See ["Pulse Train Data Exchange"](#) on page 571.

**Manual operation:** See ["Select \(ASCII\) Source/Select \(ASCII\) Destination"](#) on page 109

---

---

**[ :SOURce<hw>]:PULM:TRAI:n:DEXChange:SELEct <Filename>**

Selects the ASCII file for import or export, containing a pulse train list.

**Parameters:**

<Filename>                      string  
 Filename or complete file path; file extension can be omitted.

**Example:**                      See "Pulse Train Data Exchange" on page 571.

**Manual operation:**    See "Select Source/Select ASCII Destination" on page 109

---

**[ :SOURce<hw>]:PULM:TRAI:n:DEXChange:EXECute**

**Usage:**                          Event

**Manual operation:**    See "Import / Export" on page 109

Executes the import or export of the selected list file, according to the transfer direction set with command [ :SOURce<hw>]:PULM:TRAI:n:DEXChange:MODE.

## 14.16.2 Avionic Standards Subsystems

Option: see [Chapter 6.1, "Required Options"](#), on page 126.

The following subsections describe all commands for avionic standard modulation of the RF signal. Divided into separate avionic subsystem command sections, you can configure ADF, ILS and VOR modulation.

Programming examples are given for general configuration and avionic standard-specific configuration tasks.

### Placeholder <Subsystem>

To simplify the description of the remote control commands, the placeholder <Subsystem> is introduced. Depending on the avionic standard used as an entry standard, replace this placeholder <Subsystem> with for example SOURce:ADF for ADF.



The replacement of the place holder <Subsystem> is mandatory, i.e. remote control commands containing this placeholder are not recognized and accepted by the instrument.

**Example:**

SCPI command `<subsystem>:STATe:`

- Entry Standard = ADF  
SOURce:ADF:STATe
- Entry Standard = ILS  
SOURce:ILS:STATe
- Entry Standard = VOR  
SOURce:VOR:STATe
- Invalid command  
<Subsystem>:STAT

**Contents**

• <a href="#">Programming Examples</a> .....	575
• <a href="#">General Commands</a> .....	579
• <a href="#">SOURce:ADF Subsystem</a> .....	582
• <a href="#">SOURce:ILS Subsystem</a> .....	585
• <a href="#">SOURce:VOR Subsystem</a> .....	607

**14.16.2.1 Programming Examples****Example: Save/Recall a configuration**

This example shows how to query and load settings files, stored with the save/recall function for the ADF standard.

For other avionic standards, replace ADF by ILS or VOR.

```
SOURce1:ADF:PRESet
// Go to the "settings" directory.
MMEM:CDIR "/var/user/settings"
// List all files in the directory with extension *.adf.
SOURce1:ADF:SETTING:CATalog?
// adf_general, adf_comid

// Store the ADF configuration in the file "adf_general_latest.adf".
SOURce1:ADF:SETTING:STORe "/var/user/settings/adf_general_latest"
// Delete the file "adf_general.adf".
SOURce1:ADF:SETTING:DELeTe "/var/user/settings/adf_general"
SOURce1:ADF:SETTING:CATalog?
// adf_general_latest, adf_comid

// Load the file "adf_general_latest.adf".
SOURce1:ADF:SETTING:LOAD "/var/user/settings/adf_general_latest"

SOURce1:ADF:STATe 1
```

**Example: Configure and generate a ADF signal**

```

SOURcel:ADF:PRESet

// Configure ADF COM/ID settings.
SOURcel:ADF:COMid:PERiod 9
SOURcel:ADF:COMid:FREQuency 1020
SOURcel:ADF:COMid:DEPTh 11
SOURcel:ADF:COMid:TSCHEMA USER
SOURcel:ADF:COMid:DOT 0.11
SOURcel:ADF:COMid:DASH 0.29
SOURcel:ADF:COMid:SYMBOL 0.11
SOURcel:ADF:COMid:LETter 0.29
SOURcel:ADF:COMid:STATe 1

SOURcel:ADF:STATe 1

```

**Example: Configure and generate an ILS glide slope signal**

```

SOURcel:BB:ILS:PRESet

// Configure ILS localizer general settings.
SOURcel:ILS:TYPE GS
SOURcel:ILS:GS:FREQuency:MODE USER
SOURcel:ILS:GS:FREQuency 334700000
SOURcel:ILS:GS:FREQuency:MODE ICAO
SOURcel:ILS:GS:ICAO:CHANnel?
// CH18X
SOURcel:ILS:GS:FREQuency:SYNChronize 1
SOURcel:ILS:LOCalizer:ICAO:CHANnel?
// CH18X
SOURcel:ILS:LOCalizer:FREQuency?
// 108100000
SOURcel:ILS:GSLope:SOURce?
// INT

// Configure ILS glide slope signal settings.
SOURcel:ILS:GS:MODE NORM
SOURcel:ILS:GS:DDM:POLarity P90_150
SOURcel:ILS:GS:ULObE:FREQuency 90
SOURcel:ILS:GS:LLObE:FREQuency 150
SOURcel:ILS:GS:PHASe 0

// Configure ILS glide slope amplitude settings.
SOURcel:ILS:GS:DDM:DIRection UP
SOURcel:ILS:GS:SDM 80
SOURcel:ILS:GS:DDM:COUPling FIX
SOURcel:ILS:GS:DDM:STEP DEC
SOURcel:ILS:GS:DDM:CURREnt 0
SOURcel:ILS:GS:DDM:DEPTh 0
SOURcel:ILS:GS:DDM:LOGarithmic 0
SOURcel:ILS:GS:DDM:PCT 0

```

```
SOURcel:ILS:STATe 1
```

### Example: Configure and generate an ILS localizer signal

```
SOURcel:ILS:PRESet

// Configure ILS localizer general settings.
SOURcel:ILS:TYPE LOC
SOURcel:ILS:LOCalizer:FREQuency:MODE USER
SOURcel:ILS:LOCalizer:FREQuency 108100000
SOURcel:ILS:LOCalizer:FREQuency:SYNChronize 1
SOURcel:ILS:GS:FREQuency?
// 108100000
SOURcel:ILS:LOCalizer:FREQuency:MODE ICAO
SOURcel:ILS:LOCalizer:ICAO:CHANnel CH26Y
SOURcel:ILS:GS:ICAO:CHANnel?
// CH26Y
SOURcel:ILS:GS:FREQuency?
// 108950000
SOURcel:ILS:LOCalizer:SOURce?
// INT

// Configure ILS localizer signal settings.
SOURcel:ILS:LOCalizer:MODE NORM
SOURcel:ILS:LOCalizer:DDM:POLarity P90_150
SOURcel:ILS:LOCalizer:LLOBe:FREQuency 90
SOURcel:ILS:LOCalizer:RLOBe:FREQuency 150
SOURcel:ILS:LOCalizer:PHASe 0

// Configure ILS localizer amplitude settings.
SOURcel:ILS:LOCalizer:DDM:DIRection LEFT
SOURcel:ILS:LOCalizer:SDM 40
SOURcel:ILS:LOCalizer:DDM:COUpling FIX
SOURcel:ILS:LOCalizer:DDM:STEP DEC
SOURcel:ILS:LOCalizer:DDM:CURREnt 0
SOURcel:ILS:LOCalizer:DDM:DEPTh 0
SOURcel:ILS:LOCalizer:DDM:LOGarithmic 0
SOURcel:ILS:LOCalizer:DDM:PCT 0

// Configure ILS localizer COM/ID settings.
SOURcel:ILS:LOCalizer:COMid:CODE "MUC"
SOURcel:ILS:LOCalizer:COMid:PERiod 9
SOURcel:ILS:LOCalizer:COMid:FREQuency 1020
SOURcel:ILS:LOCalizer:COMid:DEPTh 10
SOURcel:ILS:LOCalizer:COMid:TSCHEMA USER
SOURcel:ILS:LOCalizer:COMid:DOT 0.11
SOURcel:ILS:LOCalizer:COMid:DASH 0.29
SOURcel:ILS:LOCalizer:COMid:SYMBOL 0.11
SOURcel:ILS:LOCalizer:COMid:LETTer 0.29
SOURcel:ILS:LOCalizer:COMid:STATe 1
```

```
SOURcel:ILS:STATe 1
```

### Example: Configure and generate an ILS marker beacons signal

```
SOURce:ILS:PRESet

// Configure ILS marker beacons general settings.
SOURcel:ILS:TYPE MBE
SOURcel:ILS:MBEacon:FREQuency:MODE USER
SOURcel:ILS:MBEacon:FREQuency 75000000
SOURcel:ILS:MBEacon:MARKer:FREQuency 400
SOURcel:ILS:MBEacon:MARKer:DEPTh 95
SOURcel:ILS:MBEacon:MARKer:PULSed?
// 0

// Configure ILS marker beacons COM/ID settings.
SOURcel:ILS:MBEacon:COMid:CODE "MUC"
SOURcel:ILS:MBEacon:COMid:PERiod 9
SOURcel:ILS:MBEacon:COMid:FREQuency 1020
SOURcel:ILS:MBEacon:COMid:DEPTh 5
SOURcel:ILS:MBEacon:COMid:TSCHEMA USER
SOURcel:ILS:MBEacon:COMid:DOT 0.11
SOURcel:ILS:MBEacon:COMid:DASH 0.29
SOURcel:ILS:MBEacon:COMid:SYMBOL 0.11
SOURcel:ILS:MBEacon:COMid:LETTer 0.29
SOURcel:ILS:MBEacon:COMid:STATe 1

SOURcel:BB:ILS:STATe 1
```

### Example: Configure and generate a VOR signal

```
SOURcel:VOR:PRESet

// Configure VOR general settings.
SOURcel:VOR:FREQuency:MODE USER
SOURcel:VOR:FREQuency 108000000
SOURcel:VOR:FREQuency:MODE ICAO
SOURcel:VOR:ICAO:CHANnel?
// CH17X
SOURcel:VOR:SOURce?
// INT

// Configure VOR signal settings.
SOURcel:VOR:MODE NORM
SOURcel:VOR:VAR:FREQuency 30
SOURcel:VOR:VAR:DEPTh 30
SOURcel:VOR:SUBCarrier:FREQuency 9960
SOURcel:VOR:SUBCarrier:DEPTh 30
SOURcel:VOR:REFeRence:DEVIation 480
```

```
// Configure VOR position settings.
SOURCE1:VOR:BANGLE 1
SOURCE1:VOR:BANGLE:DIRrection FROM

// Configure VOR COM/ID settings.
SOURCE1:VOR:COMid:PERiod 9
SOURCE1:VOR:COMid:FREQuency 1020
SOURCE1:VOR:COMid:DEPTh 11
SOURCE1:VOR:COMid:TSCHEMA USER
SOURCE1:VOR:COMid:DOT 0.11
SOURCE1:VOR:COMid:DASH 0.29
SOURCE1:VOR:COMid:SYMBOL 0.11
SOURCE1:VOR:COMid:LETTER 0.29
SOURCE1:VOR:COMid:STATE 1

SOURCE1:VOR:STATE 1
```

### 14.16.2.2 General Commands

<subsystem>:PRESet.....	579
[:SOURCE<hw>]:ADF:PRESet.....	579
[:SOURCE<hw>]:ILS:PRESet.....	580
[:SOURCE<hw>]:VOR:PRESet.....	580
<subsystem>:SETTING:CATalog.....	580
[:SOURCE<hw>]:ADF:SETTING:CATalog.....	580
[:SOURCE<hw>]:ILS:SETTING:CATalog?.....	580
[:SOURCE<hw>]:VOR:SETTING:CATalog?.....	580
<subsystem>:SETTING:DELeTe.....	580
[:SOURCE<hw>]:ADF:SETTING:DELeTe.....	580
[:SOURCE<hw>]:ILS:SETTING:DELeTe.....	580
[:SOURCE<hw>]:VOR:SETTING:DELeTe.....	580
<subsystem>:SETTING:LOAD.....	580
[:SOURCE<hw>]:ADF:SETTING:LOAD.....	580
[:SOURCE<hw>]:ILS:SETTING:LOAD.....	580
[:SOURCE<hw>]:VOR:SETTING:LOAD.....	580
<subsystem>:SETTING:STORe.....	581
[:SOURCE<hw>]:ADF:SETTING:STORe.....	581
[:SOURCE<hw>]:ILS:SETTING:STORe.....	581
[:SOURCE<hw>]:VOR:SETTING:STORe.....	581
<subsystem>:STATe.....	581
[:SOURCE<hw>]:ADF:STATe.....	581
[:SOURCE<hw>]:ILS:STATe.....	581
[:SOURCE<hw>]:VOR:STATe.....	581
<subsystem>:FREQuency:SYNChronize:STATe.....	581
[:SOURCE<hw>]:ILS[:GS GSLope]:FREQuency:SYNChronize[:STATe].....	581
[:SOURCE<hw>]:ILS:LOCALizer:FREQuency:SYNChronize[:STATe].....	581

---

```
<subsystem>:PRESet
[:SOURCE<hw>]:ADF:PRESet
```

**[ :SOURce<hw> ]:ILS:PRESet**  
**[ :SOURce<hw> ]:VOR:PRESet**

Sets the parameters of the digital standard to their default values (\*RST values specified for the commands).

Not affected is the state set with the command `SOURce<hw>:VOR:STATe`.

**Example:** See [Example "Save/Recall a configuration"](#) on page 575.

**<subsystem>:SETTING:CATalog**  
**[ :SOURce<hw> ]:ADF:SETTING:CATalog**  
**[ :SOURce<hw> ]:ILS:SETTING:CATalog?**  
**[ :SOURce<hw> ]:VOR:SETTING:CATalog?**

Queries the files with settings in the default directory. Listed are files with the file extension \*.adf/\*.ils/\*.vor.

**Return values:**

<FileNames> <filename1>,<filename2>,...

Returns a string of filenames separated by commas.

**Example:** See [Example "Save/Recall a configuration"](#) on page 575.

**Usage:** Query only

**<subsystem>:SETTING:DELeTe**  
**[ :SOURce<hw> ]:ADF:SETTING:DELeTe <Filename>**  
**[ :SOURce<hw> ]:ILS:SETTING:DELeTe <Filename>**  
**[ :SOURce<hw> ]:VOR:SETTING:DELeTe <Filename>**

Deletes the selected file from the default or the specified directory. Deleted are files with extension \*.adf/\*.ils/\*.vor.

**Setting parameters:**

<Filename> "<filename>"

Filename or complete file path; file extension can be omitted

**Example:** See [Example "Save/Recall a configuration"](#) on page 575.

**Usage:** Setting only

**<subsystem>:SETTING:LOAD**  
**[ :SOURce<hw> ]:ADF:SETTING:LOAD <Filename>**  
**[ :SOURce<hw> ]:ILS:SETTING:LOAD <Filename>**  
**[ :SOURce<hw> ]:VOR:SETTING:LOAD <Filename>**

Loads the selected file from the default or the specified directory. Loaded are files with extension \*.adf/\*.ils/\*.vor.

**Parameters:**

<Filename> "<filename>"

Filename or complete file path; file extension can be omitted



**Example:** See [Example "Save/Recall a configuration"](#) on page 575.

**Usage:** Setting only

```
<subsystem>:SETTING:STORe
[:SOURCE<hw>]:ADF:SETTING:STORe <Filename>
[:SOURCE<hw>]:ILS:SETTING:STORe <Filename>
[:SOURCE<hw>]:VOR:SETTING:STORe <Filename>
```

Saves the current settings into the selected file; the file extension (\*.adf/\*.ils/\*.vor) is assigned automatically.

**Parameters:**

<Filename>                    "<filename>"  
                                   Filename or complete file path

**Example:** See [Example "Save/Recall a configuration"](#) on page 575.

**Usage:** Setting only

```
<subsystem>:STATe
[:SOURCE<hw>]:ADF:STATe <State>
[:SOURCE<hw>]:ILS:STATe <State>
[:SOURCE<hw>]:VOR:STATe <State>
```

Activates/deactivates the VOR modulation.

**Parameters:**

<State>                    0 | 1 | OFF | ON  
                                   \*RST:            0

**Example:** See [Example "Save/Recall a configuration"](#) on page 575.

```
<subsystem>:FREQuency:SYNChronize:STATe
[:SOURCE<hw>]:ILS[:GS|GSLope]:FREQuency:SYNChronize[:STATe] <Mode>
[:SOURCE<hw>]:ILS:LOCALizer:FREQuency:SYNChronize[:STATe] <Mode>
```

Activates synchronization of the ILS localizer ICAO channel with the ILS glide slope ICAO channel.

The ILS glide slope/localizer frequency of the ICAO channel ([Table 6-2](#)) is set automatically.

**Parameters:**

<Mode>                    0 | 1 | OFF | ON  
                                   \*RST:            0

**Example:** See [Example "Configure and generate an ILS localizer signal"](#) on page 577.

### 14.16.2.3 SOURce:ADF Subsystem

Option: R&S SMAB-K25

The SOURce:ADF subsystem contains all commands for configuring the ADF signal.

Characteristics which are valid for all modulations and the LF output are configured in the SOURce:LFOuT subsystem. The signal is output at the LF connector.

#### Commands

[SOURce<hw>]:ADF:COMid:CODE.....	582
[SOURce<hw>]:ADF:COMid:DASH.....	582
[SOURce<hw>]:ADF:COMid:DEPT.....	583
[SOURce<hw>]:ADF:COMid:DOT.....	583
[SOURce<hw>]:ADF:COMid:FREQuency.....	583
[SOURce<hw>]:ADF:COMid:LETTer.....	583
[SOURce<hw>]:ADF:COMid:PERiod.....	584
[SOURce<hw>]:ADF:COMid:SYMBol.....	584
[SOURce<hw>]:ADF:COMid:TSCHema.....	584
[SOURce<hw>]:ADF:COMid[:STATe].....	585

---

#### [SOURce<hw>]:ADF:COMid:CODE <Code>

Sets the coding of the COM/ID signal by the international short name of the airport (e.g. MUC for the Munich airport).

The COM/ID tone is sent according to the selected code, see [Chapter C, "Morse Code Settings"](#), on page 781.

If no coding is set, the COM/ID tone is sent uncoded (key down).

#### Parameters:

<Code>                    string

**Example:**                See [Example "Configure and generate a ADF signal"](#) on page 576.

**Manual operation:**    See ["Code"](#) on page 166

---

#### [SOURce<hw>]:ADF:COMid:DASH <Dash>

Sets the length of a Morse code dash.

#### Parameters:

<Dash>                    float  
                               Range:     50E-3 to 1  
                               Increment: 1E-4  
                               \*RST:     300E-3

**Example:**                See [Example "Configure and generate a ADF signal"](#) on page 576.

**Manual operation:**    See [" Dash Length "](#) on page 167

---

**[[:SOURce<hw>]:ADF:COMid:DEPTH <Depth>**

Sets the AM modulation depth of the COM/ID signal.

**Parameters:**

<Depth>	float
	Range: 0 to 100
	Increment: 0.1
	*RST: 95

**Example:** See [Example "Configure and generate a ADF signal"](#) on page 576.

**Manual operation:** See ["Depth"](#) on page 167

---

**[[:SOURce<hw>]:ADF:COMid:DOT <Dot>**

Sets the length of a Morse code dot.

**Parameters:**

<Dot>	float
	Range: 50E-3 to 1
	Increment: 1E-4
	*RST: 100E-3

**Example:** See [Example "Configure and generate a ADF signal"](#) on page 576.

**Manual operation:** See ["Dot Length"](#) on page 167

---

**[[:SOURce<hw>]:ADF:COMid:FREQUENCY <Frequency>**

Sets the frequency of the COM/ID signal.

**Parameters:**

<Frequency>	float
	Range: 0.1 to 20E3
	Increment: 0.01
	*RST: 1020

**Example:** See [Example "Configure and generate a ADF signal"](#) on page 576.

**Manual operation:** See ["Frequency"](#) on page 167

---

**[[:SOURce<hw>]:ADF:COMid:LETTER <Letter>**

Sets the length of a Morse code letter space.

**Parameters:**

<Letter> float  
 Range: 50E-3 to 1  
 Increment: 1E-4  
 \*RST: 300E-3

**Example:** See [Example "Configure and generate a ADF signal"](#) on page 576.

**Manual operation:** See "[Letter Space](#)" on page 168

**[:SOURce<hw>]:ADF:COMid:PERiod <Period>**

Sets the period of the COM/ID signal.

**Parameters:**

<Period> float  
 Range: 0 to 120  
 Increment: 1E-3  
 \*RST: 9

**Example:** See [Example "Configure and generate a ADF signal"](#) on page 576.

**Manual operation:** See "[Period](#)" on page 167

**[:SOURce<hw>]:ADF:COMid:SYMBol <Symbol>**

Sets the length of the Morse code symbol space.

**Parameters:**

<Symbol> float  
 Range: 50E-3 to 1  
 Increment: 1E-4  
 \*RST: 100E-3

**Example:** See [Example "Configure and generate a ADF signal"](#) on page 576.

**Manual operation:** See "[Symbol Space](#)" on page 167

**[:SOURce<hw>]:ADF:COMid:TSCHEMA <TSCHEMA>**

Sets the time schema of the Morse code for the COM/ID signal.

**Parameters:**

<TSCHEMA> STD | USER  
 \*RST: STD

**Example:** See [Example "Configure and generate a ADF signal"](#) on page 576.

**Manual operation:** See "[Time Schema](#)" on page 167

**[[:SOURce<hw>]:ADF:COMid[:STATE] <State>**

Enables/disables the COM/ID signal.

**Parameters:**

<State>                    0 | 1 | OFF | ON  
 \*RST:                    0

**Example:**                See [Example "Configure and generate a ADF signal"](#) on page 576.

**Manual operation:**    See ["COM/ID State"](#) on page 166

#### 14.16.2.4 SOURce:ILS Subsystem

Option: R&S SMAB-K25

The SOURce:BB:ILS subsystem contains all commands for configuring the ILS signal.

Characteristics which are valid for all modulations and the LF output are configured in the SOURce:LFOutput subsystem. The signal is output at the LF connector.

**Commands**

[[:SOURce<hw>]:ILS:TYPE.....	586
[[:SOURce<hw>]:ILS[:GS GSLope]:DDM:COUPling.....	587
[[:SOURce<hw>]:ILS[:GS GSLope]:DDM:CURRent.....	587
[[:SOURce<hw>]:ILS[:GS GSLope]:DDM:DIRection.....	587
[[:SOURce<hw>]:ILS[:GS GSLope]:DDM:LOGarithmic.....	588
[[:SOURce<hw>]:ILS[:GS GSLope]:DDM:PCT.....	588
[[:SOURce<hw>]:ILS[:GS GSLope]:DDM:POLarity.....	588
[[:SOURce<hw>]:ILS[:GS GSLope]:DDM:STEP.....	589
[[:SOURce<hw>]:ILS[:GS GSLope]:DDM[:DEPTH].....	589
[[:SOURce<hw>]:ILS[:GS GSLope]:FREQUency.....	589
[[:SOURce<hw>]:ILS[:GS GSLope]:FREQUency:MODE.....	590
[[:SOURce<hw>]:ILS[:GS GSLope]:FREQUency:SYNChronize[:STATE].....	590
[[:SOURce<hw>]:ILS[:GS GSLope]:ICAO:CHANnel.....	590
[[:SOURce<hw>]:ILS[:GS GSLope]:LLOBe[:FREQUency].....	591
[[:SOURce<hw>]:ILS[:GS GSLope]:MODE.....	591
[[:SOURce<hw>]:ILS[:GS GSLope]:PHASe.....	591
[[:SOURce<hw>]:ILS[:GS GSLope]:PRESet.....	592
[[:SOURce<hw>]:ILS[:GS GSLope]:SDM.....	592
[[:SOURce<hw>]:ILS[:GS GSLope]:SOURce.....	592
[[:SOURce<hw>]:ILS[:GS GSLope]:ULOBe[:FREQUency].....	593
[[:SOURce<hw>]:ILS:LOCALizer:COMid:CODE.....	593
[[:SOURce<hw>]:ILS:LOCALizer:COMid:DASH.....	593
[[:SOURce<hw>]:ILS:LOCALizer:COMid:DEPTTh.....	594
[[:SOURce<hw>]:ILS:LOCALizer:COMid:DOT.....	594
[[:SOURce<hw>]:ILS:LOCALizer:COMid:FREQUency.....	594
[[:SOURce<hw>]:ILS:LOCALizer:COMid:LETTer.....	595
[[:SOURce<hw>]:ILS:LOCALizer:COMid:PERiod.....	595
[[:SOURce<hw>]:ILS:LOCALizer:COMid:SYMBOL.....	595

[SOURce<hw>]:ILS:LOCAlizer:COMid:TSCHEMA.....	595
[SOURce<hw>]:ILS:LOCAlizer:COMid[:STATe].....	596
[SOURce<hw>]:ILS:LOCAlizer:DDM:COUPLing.....	596
[SOURce<hw>]:ILS:LOCAlizer:DDM:CURRent.....	596
[SOURce<hw>]:ILS:LOCAlizer:DDM:DIRection.....	597
[SOURce<hw>]:ILS:LOCAlizer:DDM:LOGarithmic.....	597
[SOURce<hw>]:ILS:LOCAlizer:DDM:PCT.....	598
[SOURce<hw>]:ILS:LOCAlizer:DDM:POLarity.....	598
[SOURce<hw>]:ILS:LOCAlizer:DDM:STEP.....	598
[SOURce<hw>]:ILS:LOCAlizer:DDM[:DEPTH].....	599
[SOURce<hw>]:ILS:LOCAlizer:FREQUency.....	599
[SOURce<hw>]:ILS:LOCAlizer:FREQUency:MODE.....	599
[SOURce<hw>]:ILS:LOCAlizer:FREQUency:SYNChronize[:STATe].....	600
[SOURce<hw>]:ILS:LOCAlizer:ICAO:CHANnel.....	600
[SOURce<hw>]:ILS:LOCAlizer:LLOBe[:FREQUency].....	600
[SOURce<hw>]:ILS:LOCAlizer:MODE.....	601
[SOURce<hw>]:ILS:LOCAlizer:PHASe.....	601
[SOURce<hw>]:ILS:LOCAlizer:PRESet.....	601
[SOURce<hw>]:ILS:LOCAlizer:RLOBe[:FREQUency].....	602
[SOURce<hw>]:ILS:LOCAlizer:SDM.....	602
[SOURce<hw>]:ILS:LOCAlizer:SOURce.....	602
[SOURce<hw>][:ILS]:MBEacon:COMid:CODE.....	603
[SOURce<hw>][:ILS]:MBEacon:COMid:DASH.....	603
[SOURce<hw>][:ILS]:MBEacon:COMid:DEPTH.....	603
[SOURce<hw>][:ILS]:MBEacon:COMid:DOT.....	604
[SOURce<hw>][:ILS]:MBEacon:COMid:FREQUency.....	604
[SOURce<hw>][:ILS]:MBEacon:COMid:LETTer.....	604
[SOURce<hw>][:ILS]:MBEacon:COMid:PERiod.....	605
[SOURce<hw>][:ILS]:MBEacon:COMid:SYMBOL.....	605
[SOURce<hw>][:ILS]:MBEacon:COMid:TSCHEMA.....	605
[SOURce<hw>][:ILS]:MBEacon:COMid[:STATe].....	606
[SOURce<hw>][:ILS]:MBEacon:FREQUency.....	606
[SOURce<hw>][:ILS]:MBEacon:FREQUency:MODE.....	606
[SOURce<hw>][:ILS]:MBEacon:MARKer:FREQUency.....	606
[SOURce<hw>][:ILS]:MBEacon[:MARKer]:DEPTH.....	607
[SOURce<hw>][:ILS]:MBEacon:PRESet.....	607
[SOURce<hw>][:ILS]:MBEacon[:MARKer]:PULSed.....	607

---

**[SOURce<hw>]:ILS:TYPE <Type>**

Selects the ILS modulation type.

**Parameters:**

<Type> GS | LOCAlize | GSlOpe | MBEacon  
 \*RST: GS

**Example:** See [Example "Configure and generate an ILS glide slope signal"](#) on page 576.

**Manual operation:** See ["ILS Component"](#) on page 142

---

**[ :SOURce<hw> ] : ILS : GS [ GSlope ] : DDM : COUPling <Coupling>**

Selects if the DDM value is fixed or is changed with a change of sum of modulation depths (SDM, see [ :SOURce<hw> ] : ILS [ :GS | GSlope ] : SDM on page 592).

**Parameters:**

<Coupling>               FIXed | SDM  
\*RST:               FIXed

**Example:**               See [Example "Configure and generate an ILS glide slope signal"](#) on page 576.

**Manual operation:**   See ["DDM - SDM Coupling"](#) on page 149

---

**[ :SOURce<hw> ] : ILS : GS [ GSlope ] : DDM : CURRent <Current>**

Sets the DDM value alternatively as a current by means of the ILS indicating instrument. The instrument current is calculated according to:

$$\text{DDM Current } \mu\text{A} = \text{DDM Depth } [\%] \times 857,125 \mu\text{A}$$

A variation of the instrument current automatically leads to a variation of the DDM value and the DDM value in dB.

**Parameters:**

<Current>               float  
Range:               -8.57125E-4 to 8.57125E-4  
Increment:       1E-7  
\*RST:               0

**Example:**               See [Example "Configure and generate an ILS glide slope signal"](#) on page 576.

**Manual operation:**   See ["DDM Current"](#) on page 148

---

**[ :SOURce<hw> ] : ILS : GS [ GSlope ] : DDM : DIRection <Direction>**

Sets the simulation mode for the ILS glide slope modulation signal. A change of the setting automatically changes the sign of the DDM value.

**Parameters:**

<Direction>           UP | DOWN  
**UP**  
The 150-Hz modulation signal is predominant, the DDM value is negative (the airplane is too low, it must climb).  
**DOWN**  
The 90-Hz modulation signal is predominant, the DDM value is positive (the airplane is too high, it must descend).  
\*RST:               UP

**Example:**               See [Example "Configure and generate an ILS glide slope signal"](#) on page 576.

**Manual operation:** See "FlyMode" on page 148

---

**[ :SOURce<hw>]:ILS[:GS|GSLope]:DDM:LOGarithmic <Logarithmic>**

Sets the depth of modulation value for ILS glide slope modulation in dB.

See also [ :SOURce<hw> ] : ILS [ :GS | GSLope ] : DDM [ :DEPTh ] on page 589.

**Parameters:**

<Logarithmic>            float  
                                  Range:        -999.9 to 999.9  
                                  Increment:  1E-4  
                                  \*RST:        0

**Example:**                See [Example "Configure and generate an ILS glide slope signal"](#) on page 576.

**Manual operation:** See "DDM Logarithmic" on page 148

---

**[ :SOURce<hw>]:ILS[:GS|GSLope]:DDM:PCT <Pct>**

Sets the difference in depth of modulation between the signal of the upper lobe (90 Hz) and the lower lobe (150 Hz). The maximum value equals the sum of the modulation depths of the 90 Hz and the 150 Hz tone.

See also [ :SOURce<hw> ] : ILS [ :GS | GSLope ] : DDM [ :DEPTh ] on page 589.

**Parameters:**

<Pct>                        float  
                                  Range:        -80.0 to 80.0  
                                  Increment:  0.01  
                                  \*RST:        0

**Example:**                See [Example "Configure and generate an ILS glide slope signal"](#) on page 576.

**Manual operation:** See "DDM Percent" on page 149

---

**[ :SOURce<hw>]:ILS[:GS|GSLope]:DDM:POLarity <Polarity>**

Sets the polarity for DDM calculation (see [ :SOURce<hw> ] : ILS [ :GS | GSLope ] : DDM [ :DEPTh ] on page 589).

The DDM depth calculation depends on the selected polarity:

- Polarity 90 Hz - 150 Hz (default setting):  
 $DDM = [ AM(90\text{ Hz}) - AM(150\text{ Hz}) ] / 100\%$
- Polarity 150 Hz - 90 Hz:  
 $DDM = [ AM(150\text{ Hz}) - AM(90\text{ Hz}) ] / 100\%$

**Parameters:**

<Polarity>                P90\_150 | P150\_90  
                                  \*RST:        P90\_150



**Example:** See [Example "Configure and generate an ILS glide slope signal"](#) on page 576.

**Manual operation:** See ["DDM Polarity"](#) on page 146

**[:SOURce<hw>]:ILS[:GS|GSLope]:DDM:STEP <DdmStep>**

Sets the variation of the difference in depth of modulation via the rotary knob.

**Parameters:**

<DdmStep> DECimal | PREDefined  
\*RST: DECimal

**Example:** See [Example "Configure and generate an ILS glide slope signal"](#) on page 576.

**Manual operation:** See ["DDM Step"](#) on page 148

**[:SOURce<hw>]:ILS[:GS|GSLope]:DDM[:DEPTH] <Depth>**

Sets the difference in depth of modulation between the signal of the upper/left lobe (90 Hz) and the lower/right lobe (150 Hz). The maximum value equals the sum of the modulation depths of the 90 Hz and the 150 Hz tone. The following is true:

$$\text{ILS:GS|GSL:DDM:DEPTH} = (\text{AM}(90\text{Hz}) - \text{AM}(150\text{Hz})) / 100\%$$

A variation of the DDM value automatically leads to a variation of the DDM value in dB and the value of the instrument current.

**Parameters:**

<Depth> float  
Range: -0.8 to 0.8  
Increment: 1E-4  
\*RST: 0

**Example:** See [Example "Configure and generate an ILS glide slope signal"](#) on page 576.

**Manual operation:** See ["DDM Depth"](#) on page 148

**[:SOURce<hw>]:ILS[:GS|GSLope]:FREQUENCY <CarrierFreq>**

Sets the carrier frequency of the signal.

**Parameters:**

<CarrierFreq> float  
Range: 100E3 to 6E9  
Increment: 0.01  
\*RST: 334.7E6

**Example:** See [Example "Configure and generate an ILS glide slope signal"](#) on page 576.

**Manual operation:** See ["Carrier Frequency"](#) on page 144

---

**[:SOURce<hw>]:ILS[:GS|GSLope]:FREQUENCY:MODE <Mode>**

Sets the mode for the carrier frequency of the signal.

**Parameters:**

<Mode> USER | ICAO

**DECimal**

Activates user-defined variation of the carrier frequency.

**ICAO**

Activates variation in predefined steps according to standard ILS transmitting frequencies (see [Table 6-2](#)).

\*RST: DECimal

**Example:** See [Example "Configure and generate an ILS glide slope signal"](#) on page 576.

**Manual operation:** See ["Carrier Frequency Mode"](#) on page 144

---

**[:SOURce<hw>]:ILS[:GS|GSLope]:FREQUENCY:SYNChronize[:STATe] <Mode>**

Activates synchronization of the ILS glide slope ICAO channel with the ILS localizer ICAO channel.

The ILS glide slope/localizer frequency of the ICAO channel ([Table 6-2](#)) is set automatically.

**Parameters:**

<Mode> 0 | 1 | OFF | ON

\*RST: 0

**Example:** See [Example "Configure and generate an ILS glide slope signal"](#) on page 576.

---

**[:SOURce<hw>]:ILS[:GS|GSLope]:ICAO:CHANnel <Channel>**

Sets the ICAO channel and the corresponding transmitting frequency.

If avionic standard modulation is activated and you change the "RF Frequency", the frequency value of the closest ICAO channel is applied automatically. The "ICAO Channel" is also updated.

The ICAO channel settings for ILS glide slope/localizer components are coupled. For an overview of the ILS ICAO channel frequencies, see [Table 6-2](#).

**Parameters:**

<Channel> CH18X | CH18Y | CH20X | CH20Y | CH22X | CH22Y | CH24X |  
 CH24Y | CH26X | CH26Y | CH28X | CH28Y | CH30X | CH30Y |  
 CH32X | CH32Y | CH34X | CH34Y | CH36X | CH36Y | CH38X |  
 CH38Y | CH40X | CH40Y | CH42X | CH42Y | CH44X | CH44Y |  
 CH46X | CH46Y | CH48X | CH48Y | CH50X | CH50Y | CH52X |  
 CH52Y | CH54X | CH54Y | CH56X | CH56Y

\*RST: CH18X

**Example:** See [Example "Configure and generate an ILS glide slope signal"](#) on page 576.

**Manual operation:** See ["ICAO Channel"](#) on page 144

**[[:SOURce<hw>]:ILS[:GS[GSLope]:LLOBe]:FREQuency] <Frequency>**

Sets the modulation frequency of the antenna lobe arranged at the bottom viewed from the air plane for the ILS glide slope modulation signal.

**Parameters:**

<Frequency> float  
 Range: 100 to 200  
 Increment: 0.05  
 \*RST: 150

**Example:** See [Example "Configure and generate an ILS glide slope signal"](#) on page 576.

**Manual operation:** See ["Down Frequency"](#) on page 146

**[[:SOURce<hw>]:ILS[:GS[GSLope]:MODE <Mode>**

Sets the operating mode for the ILS glide slope modulation signal.

**Parameters:**

<Mode> NORM | ULOBe | LLOBe

**NORM**  
 ILS glide slope modulation is active.

**ULOBe**  
 Amplitude modulation of the output signal with the upper lobe (90Hz) signal component of the ILS glide slope signal is active.

**LLOBe**  
 Amplitude modulation of the output signal with the lower lobe (150Hz) signal component of the ILS glide slope signal is active.

\*RST: NORM

**Example:** See [Example "Configure and generate an ILS glide slope signal"](#) on page 576.

**Manual operation:** See ["Operating Mode"](#) on page 145

**[[:SOURce<hw>]:ILS[:GS[GSLope]:PHASe <Phase>**

Sets the phase between the modulation signals of the upper and lower antenna lobe of the ILS glide slope signal.

Zero crossing of the lower lobe (150Hz) signal serves as a reference. The angle refers to the period of the signal of the right antenna lobe.

**Parameters:**

<Phase> float  
 Range: -60 to 120  
 Increment: 0.01  
 \*RST: 0.0

**Example:** See [Example "Configure and generate an ILS glide slope signal"](#) on page 576.

**Manual operation:** See ["Up/Down Phase"](#) on page 146

**[ :SOURce<hw>]:ILS:GS|GSLope:PRESet**

Sets the parameters of the ILS glide slope component to their default values (\*RST values specified for the commands).

For other ILS preset commands, see [\[ :SOURce<hw>\]:ILS:PRESet](#) on page 580.

**Example:** SOURce1:ILS:GS:PRESet

**Usage:** Event

**[ :SOURce<hw>]:ILS[:GS|GSLope]:SDM <Sdm>**

Sets the arithmetic sum of the modulation depths of the upper lobe (90 Hz) and lower lobe (150 Hz) for the ILS glide slope signal contents.

The RMS modulation depth of the sum signal depends on the phase setting of both modulation tones.

**Parameters:**

<Sdm> float  
 Range: 0 to 100  
 Increment: 0.1  
 \*RST: 80

**Example:** See [Example "Configure and generate an ILS glide slope signal"](#) on page 576.

**Manual operation:** See ["Sum of Depth"](#) on page 147

**[ :SOURce<hw>]:ILS[:GS|GSLope]:SOURce <IlsGsSource>**

Sets the modulation source for the avionic standard modulation.

If external modulation source is set, the external signal is added to the internal signal. Switching off the internal modulation source is not possible.

**Parameters:**

<IlsGsSource> INT | INT,EXT | EXT  
**INT**  
 Internal modulation source is used.

**EXT|INT,EXT**

An external modulation source is used, additional to the internal modulation source.

The external signal is input at the Ext connector.

\*RST: INT

**Example:** See [Example "Configure and generate an ILS glide slope signal"](#) on page 576.

**Manual operation:** See ["EXT AM"](#) on page 144

**[[:SOURce<hw>]:ILS[:GS|GSLope]:ULOBe[:FREQUENCY] <Frequency>****Parameters:**

<Frequency> float  
 Range: 60 to 120  
 Increment: 0.03  
 \*RST: 90

**Example:** See [Example "Configure and generate an ILS glide slope signal"](#) on page 576.

**Manual operation:** See ["Up Frequency"](#) on page 146

**[[:SOURce<hw>]:ILS:LOCALizer:COMid:CODE <Code>**

Sets the coding of the COM/ID signal by the international short name of the airport (e.g. MUC for the Munich airport).

The COM/ID tone is sent according to the selected code, see [Chapter C, "Morse Code Settings"](#), on page 781.

If no coding is set, the COM/ID tone is sent uncoded (key down).

**Parameters:**

<Code> string

**Example:** See [Example "Configure and generate an ILS localizer signal"](#) on page 577.

**Manual operation:** See ["Code"](#) on page 157

**[[:SOURce<hw>]:ILS:LOCALizer:COMid:DASH <Dash>**

Sets the length of a Morse code dash.

**Parameters:**

<Dash> float  
 Range: 0.05 to 1  
 Increment: 1E-4  
 \*RST: 0.3

**Example:** See [Example "Configure and generate an ILS localizer signal"](#) on page 577.

**Manual operation:** See "[Dash Length](#)" on page 158

**[:SOURce<hw>]:ILS:LOCAlizer:COMid:DEPTH <Depth>**

Sets the AM modulation depth of the COM/ID signal.

**Parameters:**

<Depth> float  
 Range: 0 to 100  
 Increment: 0.1  
 \*RST: 10

**Example:** See [Example "Configure and generate an ILS localizer signal"](#) on page 577.

**Manual operation:** See "[Depth](#)" on page 157

**[:SOURce<hw>]:ILS:LOCAlizer:COMid:DOT <Dot>**

Sets the length of a Morse code dot.

**Parameters:**

<Dot> float  
 Range: 0.05 to 1  
 Increment: 1E-4  
 \*RST: 0.1

**Example:** See [Example "Configure and generate an ILS localizer signal"](#) on page 577.

**Manual operation:** See "[Dot Length](#)" on page 158

**[:SOURce<hw>]:ILS:LOCAlizer:COMid:FREQUency <Frequency>**

Sets the frequency of the COM/ID signal.

**Parameters:**

<Frequency> float  
 Range: 0.1 to 20E3  
 Increment: 0.01  
 \*RST: 1020

**Example:** See [Example "Configure and generate an ILS localizer signal"](#) on page 577.

**Manual operation:** See "[Frequency](#)" on page 157

---

**[[:SOURce<hw>]:ILS:LOCAlizer:COMid:LETTer <Letter>**

Sets the length of a Morse code letter space.

**Parameters:**

<Letter> float  
 Range: 0.05 to 1  
 Increment: 1E-4  
 \*RST: 0.3

**Example:** See [Example "Configure and generate an ILS localizer signal"](#) on page 577.

**Manual operation:** See " [Letter Space](#) " on page 158

---

**[[:SOURce<hw>]:ILS:LOCAlizer:COMid:PERiod <Period>**

Sets the period of the COM/ID signal.

**Parameters:**

<Period> float  
 Range: 0 to 120  
 Increment: 1E-3  
 \*RST: 9

**Example:** See [Example "Configure and generate an ILS localizer signal"](#) on page 577.

**Manual operation:** See "[Period](#)" on page 157

---

**[[:SOURce<hw>]:ILS:LOCAlizer:COMid:SYMBol <Symbol>**

Sets the length of the Morse code symbol space.

**Parameters:**

<Symbol> float  
 Range: 0.05 to 1  
 Increment: 1E-4  
 \*RST: 0.1

**Example:** See [Example "Configure and generate an ILS localizer signal"](#) on page 577.

**Manual operation:** See " [Symbol Space](#) " on page 158

---

**[[:SOURce<hw>]:ILS:LOCAlizer:COMid:TSCHEMA <TSchema>**

Sets the time schema of the Morse code for the COM/ID signal.

**Parameters:**

<TSchema> STD | USER

**STD**

Activates the standard time schema of the Morse code.

The set `dot length` determines the `dash length`, which is 3 times the dot length.

**USER**

Activates the user-defined time schema of the Morse code.

Dot and dash length, as well as `symbol` and `letter space` can be set separately.

\*RST: STD

**Example:** See [Example "Configure and generate an ILS localizer signal"](#) on page 577.

**Manual operation:** See ["Time Schema"](#) on page 158

**[ :SOURce<hw> ] :ILS:LOCalizer:COMid[:STATe] <State>**

Enables/disables the COM/ID signal.

**Parameters:**

<State> 0 | 1 | OFF | ON

\*RST: 0

**Example:** See [Example "Configure and generate an ILS localizer signal"](#) on page 577.

**Manual operation:** See ["COM/ID State"](#) on page 157

**[ :SOURce<hw> ] :ILS:LOCalizer:DDM:COUPling <Coupling>**

Selects if the DDM value is fixed or is changed with a change of sum of modulation depths (SDM, see [\[ :SOURce<hw> \] :ILS:LOCalizer:SDM](#) on page 602).

**Parameters:**

<Coupling> FIXed | SDM

\*RST: FIXed

**Example:** See [Example "Configure and generate an ILS localizer signal"](#) on page 577.

**Manual operation:** See ["DDM - SDM Coupling"](#) on page 155

**[ :SOURce<hw> ] :ILS:LOCalizer:DDM:CURRent <Current>**

Sets the DDM value alternatively as a current by means of the ILS indicating instrument. The instrument current is calculated according to:

$$\text{DDM } \mu\text{A} = \text{DDM} \times 857,1 \mu\text{A}$$

A variation of the instrument current automatically leads to a variation of the DDM value and the DDM value in dB.



**Parameters:**

<Current> float  
 Range: -9.6775E-4 to 9.6775E-4  
 Increment: 1E-7  
 \*RST: 0

**Example:** See [Example "Configure and generate an ILS localizer signal"](#) on page 577.

**Manual operation:** See ["DDM Current"](#) on page 155

**[ :SOURce<hw>]:ILS:LOCalizer:DDM:DIRection <Direction>**

Sets the simulation mode for the ILS-LOC modulation signal. A change of the setting automatically changes the sign of the DDM value.

**Parameters:**

<Direction> LEFT | RIGHT  
**LEFT**  
 The 150 Hz modulation signal is predominant, the DDM value is negative (the airplane is too far to the right, it must turn to the left).  
**RIGHT**  
 The 90 Hz modulation signal is predominant, the DDM value is positive (the airplane is too far to the left, it must turn to the right).  
 \*RST: LEFT

**Example:** See [Example "Configure and generate an ILS localizer signal"](#) on page 577.

**Manual operation:** See ["FlyMode"](#) on page 154

**[ :SOURce<hw>]:ILS:LOCalizer:DDM:LOGarithmic <Logarithmic>**

Sets the modulation depth in dB for ILS localizer modulation.

See also [\[:SOURce<hw>\]:ILS:LOCalizer:DDM\[:DEPTh\]](#) on page 599.

**Parameters:**

<Logarithmic> float  
 Range: -999.9 to 999.9  
 Increment: 1E-4  
 \*RST: 0

**Example:** See [Example "Configure and generate an ILS localizer signal"](#) on page 577.

**Manual operation:** See ["DDM Logarithmic"](#) on page 156

**[ :SOURce<hw>]:ILS:LOCAlizer:DDM:PCT <Pct>**

Sets the difference in depth of modulation between the signal of the left lobe (90 Hz) and the right lobe (150 Hz). The maximum value equals the sum of the modulation depths of the 90 Hz and the 150 Hz tone.

See also [\[:SOURce<hw>\]:ILS:LOCAlizer:DDM\[:DEPTh\]](#) on page 599.

**Parameters:**

<Pct> float  
 Range: -80.0 to 80.0  
 Increment: 0.01  
 \*RST: 0

**Example:** See [Example "Configure and generate an ILS localizer signal"](#) on page 577.

**Manual operation:** See ["DDM Percent"](#) on page 156

**[ :SOURce<hw>]:ILS:LOCAlizer:DDM:POLarity <Polarity>**

Sets the polarity for DDM calculation (see [\[:SOURce<hw>\]:ILS:LOCAlizer:DDM\[:DEPTh\]](#)).

The DDM depth calculation depends on the selected polarity:

- Polarity 90 Hz - 150 Hz (default setting):  
 $DDM = [ AM(90\text{ Hz}) - AM(150\text{ Hz}) ] / 100\%$
- Polarity 150 Hz - 90 Hz:  
 $DDM = [ AM(150\text{ Hz}) - AM(90\text{ Hz}) ] / 100\%$

**Parameters:**

<Polarity> P90\_150 | P150\_90  
 \*RST: P90\_150

**Example:** See [Example "Configure and generate an ILS localizer signal"](#) on page 577.

**Manual operation:** See ["DDM polarity"](#) on page 153

**[ :SOURce<hw>]:ILS:LOCAlizer:DDM:STEP <DdmStep>**

Sets the variation step of the DDM values.

**Parameters:**

<DdmStep> DECimal | PREDefined  
 \*RST: DECimal

**Example:** See [Example "Configure and generate an ILS localizer signal"](#) on page 577.

**Manual operation:** See ["DDM Step"](#) on page 155

---

**[[:SOURce<hw>]:ILS:LOCALizer:DDM[:DEPT] <Depth>**

Sets the difference in depth of modulation between the signal of the upper/left lobe (90 Hz) and the lower/right lobe (150 Hz). The maximum value equals the sum of the modulation depths of the 90 Hz and the 150 Hz tone. The following is true:

$$\text{ILS:LOC:DDM:DEPT} = (\text{AM}(90\text{Hz}) - \text{AM}(150\text{Hz})) / 100\%$$

A variation of the DDM value automatically leads to a variation of the DDM value in dB and the value of the instrument current.

**Parameters:**

<Depth> float  
 Range: -0.4 to 0.4  
 Increment: 1E-4  
 \*RST: 0

**Example:** See [Example "Configure and generate an ILS localizer signal"](#) on page 577.

**Manual operation:** See ["DDM Depth"](#) on page 155

---

**[[:SOURce<hw>]:ILS:LOCALizer:FREQUENCY <CarrierFreq>**

Sets the carrier frequency of the signal.

**Parameters:**

<CarrierFreq> float  
 Range: 100E3 to 6E9  
 Increment: 0.01  
 \*RST: 108.1E6

**Example:** See [Example "Configure and generate an ILS localizer signal"](#) on page 577.

**Manual operation:** See ["Carrier Frequency"](#) on page 150

---

**[[:SOURce<hw>]:ILS:LOCALizer:FREQUENCY:MODE <IlsLocFreqMode>**

Sets the mode for the carrier frequency of the signal.

**Parameters:**

<Mode> DECimal | ICAO

**DECimal**

Activates user-defined variation of the carrier frequency.

**ICAO**

Activates variation in predefined steps according to standard ILS transmitting frequencies (see [Table 6-2](#)).

\*RST: DECimal

**Example:** See [Example "Configure and generate an ILS localizer signal"](#) on page 577.

**Manual operation:** See ["Carrier Frequency Mode"](#) on page 150

---

**[[:SOURce<hw>]:ILS:LOCalizer:FREQUENCY:SYNChronize[:STATE] <Mode>**

Activates synchronization of the ILS localizer ICAO channel with the ILS glide slope ICAO channel.

The ILS glide slope/localizer frequency of the ICAO channel ([Table 6-2](#)) is set automatically.

**Parameters:**

<Mode> 0 | 1 | OFF | ON  
\*RST: 0

**Example:** See [Example "Configure and generate an ILS localizer signal"](#) on page 577.

---

**[[:SOURce<hw>]:ILS:LOCalizer:ICAO:CHANnel <SellcaoChan>**

Sets the ICAO channel and the corresponding transmitting frequency.

If avionic standard modulation is activated and you change the "RF Frequency", the frequency value of the closest ICAO channel is applied automatically. The "ICAO Channel" is also updated.

The ICAO channel settings for ILS glide slope/localizer components are coupled. For an overview of the ILS ICAO channel frequencies, see [Table 6-2](#).

**Parameters:**

<SellcaoChan> CH18X | CH18Y | CH20X | CH20Y | CH22X | CH22Y | CH24X |  
CH24Y | CH26X | CH26Y | CH28X | CH28Y | CH30X | CH30Y |  
CH32X | CH32Y | CH34X | CH34Y | CH36X | CH36Y | CH38X |  
CH38Y | CH40X | CH40Y | CH42X | CH42Y | CH44X | CH44Y |  
CH46X | CH46Y | CH48X | CH48Y | CH50X | CH50Y | CH52X |  
CH52Y | CH54X | CH54Y | CH56X | CH56Y  
\*RST: CH18X

**Example:** See [Example "Configure and generate an ILS localizer signal"](#) on page 577.

**Manual operation:** See ["ICAO Channel"](#) on page 151

---

**[[:SOURce<hw>]:ILS:LOCalizer:LLOBe[:FREQUENCY] <Frequency>**

Sets the modulation frequency of the antenna lobe arranged at the bottom viewed from the air plane for the ILS localizer modulation signal.

**Parameters:**

<Frequency> float  
Range: 60 to 120  
Increment: 0.03  
\*RST: 90

**Example:** See [Example "Configure and generate an ILS localizer signal"](#) on page 577.

**Manual operation:** See ["Left Frequency"](#) on page 153

**[ :SOURce<hw>]:ILS:LOCalizer:MODE <Mode>**

Sets the operating mode for the ILS localizer modulation signal.

**Parameters:**

<Mode> NORM | LLOBe | RLOBe

**NORM**

ILS localizer modulation is active.

**LLOBe**

Amplitude modulation of the output signal with the left lobe (90Hz) signal component of the ILS localizer signal is active.

**RLOBe**

Amplitude modulation of the output signal with the right lobe (150Hz) signal component of the ILS localizer signal is active.

\*RST: NORM

**Example:** See [Example "Configure and generate an ILS localizer signal"](#) on page 577.

**Manual operation:** See ["Operating Mode"](#) on page 152

**[ :SOURce<hw>]:ILS:LOCalizer:PHASe <Phase>**

Sets the phase between the modulation signals of the left and right antenna lobe of the ILS localizer signal.

The zero crossing of the right lobe (150Hz) signal serves as a reference. The angle refers to the period of the signal of the right antenna lobe.

**Parameters:**

<Phase> float  
 Range: -60 to 120  
 Increment: 0.01  
 \*RST: 0

**Example:** See [Example "Configure and generate an ILS localizer signal"](#) on page 577.

**Manual operation:** See ["Left/Right Phase"](#) on page 153

**[ :SOURce<hw>]:ILS:LOCalizer:PRESet**

Sets the parameters of the ILS localizer component to their default values (\*RST values specified for the commands).

For other ILS preset commands, see [\[ :SOURce<hw>\]:ILS:PRESet](#) on page 580.

**Example:** SOURce1:ILS:LOCalizer:PRESet

**Usage:** Event

**[:SOURce<hw>]:ILS:LOCalizer:RLOBe[:FREQuency] <Frequency>**

Sets the modulation frequency of the antenna lobe arranged at the right viewed from the air plane.

**Parameters:**

<Frequency> float  
 Range: 100 to 200  
 Increment: 0.05  
 \*RST: 150

**Example:** See [Example "Configure and generate an ILS localizer signal"](#) on page 577.

**Manual operation:** See ["Right Frequency"](#) on page 153

**[:SOURce<hw>]:ILS:LOCalizer:SDM <Sdm>**

Sets the arithmetic sum of the modulation depths of the left lobe (90 Hz) and right lobe (150 Hz) for the ILS localizer signal contents.

The RMS modulation depth of the sum signal depends on the phase setting of both modulation tones.

**Parameters:**

<Sdm> float  
 Range: 0 to 100  
 Increment: 0.1  
 \*RST: 40

**Example:** See [Example "Configure and generate an ILS localizer signal"](#) on page 577.

**Manual operation:** See ["Sum of Depth"](#) on page 154

**[:SOURce<hw>]:ILS:LOCalizer:SOURce <ILsLocSource>**

Sets the modulation source for the avionic standard modulation.

If external modulation source is set, the external signal is added to the internal signal. Switching off the internal modulation source is not possible.

**Parameters:**

<ILsLocSource> INT | INT,EXT | EXT  
**INT**  
 Internal modulation source is used.

**EXT|INT,EXT**

An external modulation source is used, additional to the internal modulation source.

The external signal is input at the Ext connector.

\*RST: INT

**Example:** See [Example "Configure and generate an ILS localizer signal"](#) on page 577.

**Manual operation:** See ["EXT AM"](#) on page 151

**[[:SOURce<hw>][:ILS]:MBEacon:COMid:CODE <Code>**

Sets the coding of the COM/ID signal by the international short name of the airport (e.g. MUC for the Munich airport).

The COM/ID tone is sent according to the selected code, see [Chapter C, "Morse Code Settings"](#), on page 781.

If no coding is set, the COM/ID tone is sent uncoded (key down).

**Parameters:**

<Code> string

**Example:** See [Example "Configure and generate an ILS marker beacons signal"](#) on page 578.

**Manual operation:** See ["Code"](#) on page 162

**[[:SOURce<hw>][:ILS]:MBEacon:COMid:DASH <Dash>**

Sets the length of a Morse code dash.

**Parameters:**

<Dash> float  
 Range: 0.05 to 1  
 Increment: 1E-4  
 \*RST: 0.3

**Example:** See [Example "Configure and generate an ILS marker beacons signal"](#) on page 578.

**Manual operation:** See ["Dash Length"](#) on page 163

**[[:SOURce<hw>][:ILS]:MBEacon:COMid:DEPTH <Depth>**

Sets the AM modulation depth of the COM/ID signal.

**Parameters:**

<Depth> float  
 Range: 0 to 100  
 Increment: 0.1  
 \*RST: 5

**Example:** See [Example "Configure and generate an ILS marker beacons signal"](#) on page 578.

**Manual operation:** See ["Depth"](#) on page 162

**[[:SOURce<hw>]:[:ILS]:MBEacon:COMid:DOT <Dot>**

Sets the length of a Morse code dot.

**Parameters:**

<Dot>	float
	Range: 0.05 to 1
	Increment: 1E-4
	*RST: 0.1

**Example:** See [Example "Configure and generate an ILS marker beacons signal"](#) on page 578.

**Manual operation:** See ["Dot Length"](#) on page 163

**[[:SOURce<hw>]:[:ILS]:MBEacon:COMid:FREQUENCY <Frequency>**

Sets the frequency of the COM/ID signal.

**Parameters:**

<Frequency>	float
	Range: 0.1 to 20E3
	Increment: 0.01
	*RST: 1020

**Example:** See [Example "Configure and generate an ILS marker beacons signal"](#) on page 578.

**Manual operation:** See ["Frequency"](#) on page 162

**[[:SOURce<hw>]:[:ILS]:MBEacon:COMid:LETTER <Letter>**

Sets the length of a Morse code letter space.

**Parameters:**

<Letter>	float
	Range: 0.05 to 1
	Increment: 1E-4
	*RST: 0.3

**Example:** See [Example "Configure and generate an ILS marker beacons signal"](#) on page 578.

**Manual operation:** See [" Letter Space"](#) on page 163



---

```
[[:SOURce<hw>]][:ILS]:MBEacon:COMid:PERiod <Period>
```

Sets the period of the COM/ID signal.

**Parameters:**

```
<Period>          float
                  Range:    0 to 120
                  Increment: 1E-3
                  *RST:     9
```

**Example:** See [Example "Configure and generate an ILS marker beacons signal"](#) on page 578.

**Manual operation:** See ["Period"](#) on page 162

---

```
[[:SOURce<hw>]][:ILS]:MBEacon:COMid:SYMBol <Symbol>
```

Sets the length of the Morse code symbol space.

**Parameters:**

```
<Symbol>          float
                  Range:    0.05 to 1
                  Increment: 1E-4
                  *RST:     0.1
```

**Example:** See [Example "Configure and generate an ILS marker beacons signal"](#) on page 578.

**Manual operation:** See ["Symbol Space"](#) on page 163

---

```
[[:SOURce<hw>]][:ILS]:MBEacon:COMid:TSCHEMA <Tschema>
```

Sets the time schema of the Morse code for the COM/ID signal.

**Parameters:**

```
<Tschema>          STD | USER
```

**STD**

Activates the standard time schema of the Morse code.

The set [dot length](#) determines the [dash length](#), which is 3 times the dot length.

**USER**

Activates the user-defined time schema of the Morse code.

Dot and dash length, as well as [symbol](#) and [letter space](#) can be set separately.

```
*RST:          STD
```

**Example:** See [Example "Configure and generate an ILS marker beacons signal"](#) on page 578.

**Manual operation:** See ["Time Schema"](#) on page 162

---

**[[:SOURce<hw>]:[:ILS]:MBEacon:COMid[:STATe] <State>**

Enables/disables the COM/ID signal.

**Parameters:**

<State>                    0 | 1 | OFF | ON  
 \*RST:                    0

**Example:**                See [Example "Configure and generate an ILS marker beacons signal"](#) on page 578.

**Manual operation:**    See ["COM/ID State"](#) on page 162

---

**[[:SOURce<hw>]:[:ILS]:MBEacon:FREQuency <CarrierFreq>**

Sets the carrier frequency for the ILS marker beacon signal.

**Parameters:**

<CarrierFreq>            float  
                               Range:        100E3 to 6E9  
                               Increment: 0.01  
                               \*RST:        75E6

**Example:**                See [Example "Configure and generate an ILS marker beacons signal"](#) on page 578.

**Manual operation:**    See ["Carrier Frequency"](#) on page 159

---

**[[:SOURce<hw>]:[:ILS]:MBEacon:FREQuency:MODE <Mode>**

Sets the carrier frequency mode of the ILS marker beacon signal.

**Parameters:**

<Mode>                    USER | PREDefined  
 \*RST:                    USER

**Example:**                See [Example "Configure and generate an ILS marker beacons signal"](#) on page 578.

**Manual operation:**    See ["Carrier Frequency Mode"](#) on page 159

---

**[[:SOURce<hw>]:[:ILS]:MBEacon:MARKer:FREQuency <Frequency>**

Sets the modulation frequency of the marker signal for the ILS marker beacon modulation signal.

**Parameters:**

<Frequency>            400 | 1300 | 3000  
                               \*RST:        400  
                               Default unit: Hz

**Example:**                See [Example "Configure and generate an ILS marker beacons signal"](#) on page 578.

**Manual operation:** See ["Marker Frequency"](#) on page 160

---

**[ :SOURce<hw> ] [ :ILS ] :MBEacon [ :MARKer ] :DEPTh <Depth>**

Sets the modulation depth of the marker signal for the ILS marker beacon signal.

**Parameters:**

<Depth> float  
 Range: 0 to 100  
 Increment: 0.1  
 \*RST: 95

**Example:** See [Example "Configure and generate an ILS marker beacons signal"](#) on page 578.

**Manual operation:** See ["Marker Depth"](#) on page 160

---

**[ :SOURce<hw> ] [ :ILS ] :MBEacon :PRESet**

Sets the parameters of the ILS marker beacons component to their default values (\*RST values specified for the commands).

For other ILS preset commands, see [\[ :SOURce<hw> \] :ILS :PRESet](#) on page 580.

**Example:** SOURce1 : ILS : MBEacon : PRESet

**Usage:** Event

---

**[ :SOURce<hw> ] [ :ILS ] :MBEacon [ :MARKer ] :PULSed <Pulsed>**

Activates the modulation of a pulsed marker signal (morse coding).

**Parameters:**

<Pulsed> 0 | 1 | OFF | ON  
 \*RST: 0

**Example:** See [Example "Configure and generate an ILS marker beacons signal"](#) on page 578.

**Manual operation:** See ["Pulsed Marker"](#) on page 160

#### 14.16.2.5 SOURce:VOR Subsystem

Option: R&S SMAB-K25

The SOURce:VOR subsystem contains all commands for configuring the VOR signal.

Characteristics which are valid for all modulations and the LF output are configured in the [SOURce:LFOutput](#) subsystem. The signal is output at the LF connector.

**Commands**

<code>[[:SOURce&lt;hw&gt;]:VOR:SOURce</code> .....	608
<code>[[:SOURce&lt;hw&gt;]:VOR[:BANGle]</code> .....	608
<code>[[:SOURce&lt;hw&gt;]:VOR[:BANGle]:DIRection</code> .....	609
<code>[[:SOURce&lt;hw&gt;]:VOR:COMid:CODE</code> .....	609
<code>[[:SOURce&lt;hw&gt;]:VOR:COMid:DASH</code> .....	610
<code>[[:SOURce&lt;hw&gt;]:VOR:COMid:DEPT</code> .....	610
<code>[[:SOURce&lt;hw&gt;]:VOR:COMid:DOT</code> .....	610
<code>[[:SOURce&lt;hw&gt;]:VOR:COMid:FREQuency</code> .....	610
<code>[[:SOURce&lt;hw&gt;]:VOR:COMid:LETTer</code> .....	611
<code>[[:SOURce&lt;hw&gt;]:VOR:COMid:PERiod</code> .....	611
<code>[[:SOURce&lt;hw&gt;]:VOR:COMid:SYMBol</code> .....	611
<code>[[:SOURce&lt;hw&gt;]:VOR:COMid:TSCHEMA</code> .....	612
<code>[[:SOURce&lt;hw&gt;]:VOR:COMid[:STATe]</code> .....	612
<code>[[:SOURce&lt;hw&gt;]:VOR:FREQuency</code> .....	612
<code>[[:SOURce&lt;hw&gt;]:VOR:FREQuency:MODE</code> .....	613
<code>[[:SOURce&lt;hw&gt;]:VOR:ICAO:CHANnel</code> .....	613
<code>[[:SOURce&lt;hw&gt;]:VOR:MODE</code> .....	614
<code>[[:SOURce&lt;hw&gt;]:VOR:REFerence[:DEViation]</code> .....	615
<code>[[:SOURce&lt;hw&gt;]:VOR:SUBCarrier:DEPT</code> .....	615
<code>[[:SOURce&lt;hw&gt;]:VOR:SUBCarrier[:FREQuency]</code> .....	615
<code>[[:SOURce&lt;hw&gt;]:VOR:VAR:FREQuency</code> .....	616
<code>[[:SOURce&lt;hw&gt;]:VOR:VAR[:DEPT]</code> .....	616

**[[:SOURce<hw>]:VOR:SOURce <VorSourceSel>**

Sets the modulation source for the avionic standard modulation.

If external modulation source is set, the external signal is added to the internal signal. Switching off the internal modulation source is not possible.

**Parameters:**

<VorSourceSel> INT | INT,EXT | EXT

**INT**

Internal modulation source is used.

**EXT|INT,EXT**

An external modulation source is used, additional to the internal modulation source.

The external signal is input at the Ext connector.

\*RST: INT

**Example:** See [Example "Configure and generate a VOR signal"](#) on page 578.

**Manual operation:** See ["EXT AM"](#) on page 135

**[[:SOURce<hw>]:VOR[:BANGle] <BAngle>**

Sets the bearing angle between the VAR signal and the reference signal.

The orientation of the angle can be set with `[ :SOURce<hw> ] :VOR [ :BANGLe ] :DIRection`.

**Parameters:**

<BAngle> float  
 Range: 0 to 360  
 Increment: 0.01  
 \*RST: 0

**Example:** See [Example "Configure and generate a VOR signal"](#) on page 578.

**Manual operation:** See ["Bearing Angle"](#) on page 137

`[ :SOURce<hw> ] :VOR [ :BANGLe ] :DIRection <Direction>`

Sets the reference position of the phase information.

**Parameters:**

<Direction> FROM | TO

**FROM**

The bearing angle is measured between the geographic north and the connection line from beacon to airplane.

**TO**

The bearing angle is measured between the geographic north and the connection line from airplane to beacon.

\*RST: FROM

**Example:** See [Example "Configure and generate a VOR signal"](#) on page 578.

**Manual operation:** See ["Direction"](#) on page 137

`[ :SOURce<hw> ] :VOR :COMid :CODE <Code>`

Sets the coding of the COM/ID signal by the international short name of the airport (e.g. MUC for the Munich airport).

The COM/ID tone is sent according to the selected code, see [Chapter C, "Morse Code Settings"](#), on page 781.

If no coding is set, the COM/ID tone is sent uncoded (key down).

**Parameters:**

<Code> string

**Example:** See [Example "Configure and generate a VOR signal"](#) on page 578.

**Manual operation:** See ["Code"](#) on page 139

---

**[[:SOURce<hw>]:VOR:COMid:DASH <Dash>**

Sets the length of a Morse code dash.

**Parameters:**

<Dash>	float
	Range: 0.05 to 1
	Increment: 1E-4
	*RST: 0.3

**Example:** See [Example "Configure and generate a VOR signal"](#) on page 578.

**Manual operation:** See ["Dash Length"](#) on page 139

---

**[[:SOURce<hw>]:VOR:COMid:DEPTH <Depth>**

Sets the AM modulation depth of the COM/ID signal.

**Parameters:**

<Depth>	float
	Range: 0 to 100
	Increment: 0.1
	*RST: 10

**Example:** See [Example "Configure and generate a VOR signal"](#) on page 578.

**Manual operation:** See ["Depth"](#) on page 139

---

**[[:SOURce<hw>]:VOR:COMid:DOT <Dot>**

Sets the length of a Morse code dot.

If the [time schema](#) is set to standard, the dash length (= 3 times dot length), symbol space (= dot length) and letter space (= 3 times dot length) is also determined by this entry.

**Parameters:**

<Dot>	float
	Range: 0.05 to 1
	Increment: 1E-4
	*RST: 0.1

**Example:** See [Example "Configure and generate a VOR signal"](#) on page 578.

**Manual operation:** See ["Dot Length"](#) on page 139

---

**[[:SOURce<hw>]:VOR:COMid:FREQuency <Frequency>**

Sets the frequency of the COM/ID signal.

**Parameters:**

<Frequency> float  
 Range: 0.1 to 20E3  
 Increment: 0.01  
 \*RST: 1020

**Example:** See [Example "Configure and generate a VOR signal"](#) on page 578.

**Manual operation:** See ["Frequency"](#) on page 139

**[:SOURce<hw>]:VOR:COMid:LETter <Letter>**

Sets the length of a Morse code letter space.

**Parameters:**

<Letter> float  
 Range: 0.05 to 1  
 Increment: 1E-4  
 \*RST: 0.3  
 Default unit: s

**Example:** See [Example "Configure and generate a VOR signal"](#) on page 578.

**Manual operation:** See [" Letter Space "](#) on page 140

**[:SOURce<hw>]:VOR:COMid:PERiod <Period>**

Sets the period of the COM/ID signal.

**Parameters:**

<Period> float  
 Range: 0 to 120  
 Increment: 1E-3  
 \*RST: 9

**Example:** See [Example "Configure and generate a VOR signal"](#) on page 578.

**Manual operation:** See ["Period"](#) on page 139

**[:SOURce<hw>]:VOR:COMid:SYMBol <Symbol>**

Sets the length of the Morse code symbol space.

**Parameters:**

<Symbol> float  
 Range: 0.05 to 1  
 Increment: 1E-4  
 \*RST: 0.1

**Example:** See [Example "Configure and generate a VOR signal"](#) on page 578.

**Manual operation:** See "[Symbol Space](#)" on page 140

**[[:SOURce<hw>]:VOR:COMid:TSCHEMA <Tschema>**

Sets the time schema of the Morse code for the COM/ID signal.

**Parameters:**

<Tschema> STD | USER

**STD**

Activates the standard time schema of the Morse code.

The set [dot length](#) determines the [dash length](#), which is 3 times the dot length.

**USER**

Activates the user-defined time schema of the Morse code.

Dot and dash length, as well as [symbol](#) and [letter space](#) can be set separately.

\*RST: STD

**Example:** See [Example "Configure and generate a VOR signal"](#) on page 578.

**Manual operation:** See "[Time Schema](#)" on page 139

**[[:SOURce<hw>]:VOR:COMid:STATE] <State>**

Enables/disables the COM/ID signal.

**Parameters:**

<State> 0 | 1 | OFF | ON

\*RST: 0

**Example:** See [Example "Configure and generate a VOR signal"](#) on page 578.

**Manual operation:** See "[COM/ID State](#)" on page 138

**[[:SOURce<hw>]:VOR:FREQUENCY <CarrierFreq>**

Sets the carrier frequency of the signal.

**Parameters:**

<CarrierFreq> float

Range: 100E3 to 6E9

Increment: 0.01

\*RST: 108E6

**Example:** See [Example "Configure and generate a VOR signal"](#) on page 578.



**Manual operation:** See ["Carrier Frequency"](#) on page 134

---

**[:SOURce<hw>]:VOR:FREQuency:MODE <Mode>**

Sets the mode for the carrier frequency of the signal.

**Parameters:**

<Mode> DECimal | ICAO

**DECimal**

Activates user-defined variation of the carrier frequency.

**ICAO**

Activates variation in predefined steps according to standard VOR transmitting frequencies (see [Table 6-1](#)).

\*RST: DECimal

**Example:** See [Example "Configure and generate a VOR signal"](#) on page 578.

**Manual operation:** See ["Carrier Frequency Mode"](#) on page 134

---

**[:SOURce<hw>]:VOR:ICAO:CHANnel <Channel>**

Sets the ICAO channel and the corresponding transmitting frequency.

If avionic standard modulation is activated and you change the "RF Frequency", the frequency value of the closest ICAO channel is applied automatically. The "ICAO Channel" is also updated.

The carrier frequency is set automatically to the value of the ICAO channel. For an overview of the VOR ICAO channel frequencies, see [Table 6-1](#).

**Parameters:**

<Channel> CH17X | CH17Y | CH19X | CH19Y | CH21X | CH21Y | CH23X | CH23Y | CH25X | CH25Y | CH27X | CH27Y | CH29X | CH29Y | CH31X | CH31Y | CH33X | CH33Y | CH35X | CH35Y | CH37X | CH37Y | CH39X | CH39Y | CH41X | CH41Y | CH43X | CH43Y | CH45X | CH45Y | CH47X | CH47Y | CH49X | CH49Y | CH51X | CH51Y | CH53X | CH53Y | CH55X | CH55Y | CH57X | CH57Y | CH58X | CH58Y | CH59X | CH59Y | CH70X | CH70Y | CH71X | CH71Y | CH72X | CH72Y | CH73X | CH73Y | CH74X | CH74Y | CH75X | CH75Y | CH76X | CH76Y | CH77X | CH77Y | CH78X | CH78Y | CH79X | CH79Y | CH80X | CH80Y | CH81X | CH81Y | CH82X | CH82Y | CH83X | CH83Y | CH84X | CH84Y | CH85X | CH85Y | CH86X | CH86Y | CH87X | CH87Y | CH88X | CH88Y | CH89X | CH89Y | CH90X | CH90Y | CH91X | CH91Y | CH92X | CH92Y | CH93X | CH93Y | CH94X | CH94Y | CH95X | CH95Y | CH96X | CH96Y | CH97X | CH97Y | CH98X | CH98Y | CH99X | CH99Y | CH100X | CH100Y | CH101X | CH101Y | CH102X | CH102Y | CH103X | CH103Y | CH104X | CH104Y | CH105X | CH105Y | CH106X | CH106Y | CH107X | CH107Y | CH108X | CH108Y | CH109X | CH109Y | CH110X | CH110Y | CH111X | CH111Y | CH112X | CH112Y | CH113X | CH113Y | CH114X | CH114Y | CH115X | CH115Y | CH116X | CH116Y | CH117X | CH117Y | CH118X | CH118Y | CH119X | CH119Y | CH120X | CH120Y | CH121X | CH121Y | CH122X | CH122Y | CH123X | CH123Y | CH124X | CH124Y | CH125X | CH125Y | CH126X | CH126Y

\*RST: CH17X

**Example:** See [Example "Configure and generate a VOR signal"](#) on page 578.

**Manual operation:** See ["ICAO Channel"](#) on page 134

---

**[ :SOURce<hw>]:VOR:MODE <Mode>**

Sets the operating mode for the VOR modulation signal.

**Parameters:**

<Mode> NORM | VAR | SUBCarrier | FMSubcarrier

**NORM**

VOR modulation is active.

**VAR**

Amplitude modulation of the output signal with the variable signal component (30Hz signal content) of the VOR signal.

The modulation depth of the 30 Hz signal can be set with [ :SOURce<hw> ] :VOR:VAR [ :DEPT h ] .

**SUBCarrier**

Amplitude modulation of the output signal with the unmodulated FM carrier (9960Hz) of the VOR signal.

The modulation depth of the 30 Hz signal can be set with [:SOURce<hw>]:VOR:SUBCarrier:DEPTh.

**FMSubcarrier**

Amplitude modulation of the output signal with the frequency modulated FM carrier (9960Hz) of the VOR signal.

The modulation depth of the 30 Hz signal can be set with [:SOURce<hw>]:VOR:SUBCarrier:DEPTh.

The frequency deviation can be set with [:SOURce<hw>]:VOR:REFerence[:DEViation].

\*RST: NORM

**Example:** See [Example "Configure and generate a VOR signal"](#) on page 578.

**Manual operation:** See ["Mode"](#) on page 136

**[[:SOURce<hw>]:VOR:REFerence[:DEViation] <Deviation>**

Sets the frequency deviation of the reference signal on the FM carrier.

**Parameters:**

<Deviation> integer  
 Range: 0 to 960  
 \*RST: 480

**Example:** See [Example "Configure and generate a VOR signal"](#) on page 578.

**Manual operation:** See ["REF Deviation"](#) on page 137

**[[:SOURce<hw>]:VOR:SUBCarrier:DEPTh <Depth>**

Sets the AM modulation depth of the FM carrier.

**Parameters:**

<Depth> float  
 Range: 0 to 100  
 Increment: 0.1  
 \*RST: 30

**Example:** See [Example "Configure and generate a VOR signal"](#) on page 578.

**Manual operation:** See [" Subcarrier Depth "](#) on page 136

**[[:SOURce<hw>]:VOR:SUBCarrier[:FREQUENCY] <Frequency>**

Sets the frequency of the FM carrier.

**Parameters:**

<Frequency> float  
 Range: 5E3 to 15E3  
 Increment: 0.01  
 \*RST: 9.96E3

**Example:** See [Example "Configure and generate a VOR signal"](#) on page 578.

**Manual operation:** See ["Subcarrier Frequency"](#) on page 136

**[:SOURce<hw>]:VOR:VAR:FREQuency** <Frequency>

Sets the frequency of the variable and the reference signal. As the two signals must have the same frequency, the setting is valid for both signals.

**Parameters:**

<Frequency> float  
 Range: 10 to 60  
 Increment: 0.01  
 \*RST: 30

**Example:** See [Example "Configure and generate a VOR signal"](#) on page 578.

**Manual operation:** See ["VAR/REF Frequency"](#) on page 136

**[:SOURce<hw>]:VOR:VAR[:DEPT]h** <Depth>

Sets the AM modulation depth of the 30Hz variable signal.

**Parameters:**

<Depth> float  
 Range: 0 to 100  
 Increment: 0.1  
 \*RST: 30

**Example:** See [Example "Configure and generate a VOR signal"](#) on page 578.

**Manual operation:** See ["VAR Depth"](#) on page 136

### 14.16.3 SOURce:CORRection Subsystem

The SOURce:CORRection subsystem contains the commands for defining correction values for external test assemblies.

You can acquire the correction values any time, regardless of the modulation settings of the generator. The correction is performed by adding the correction values to the output level of the respective RF frequency.

Determine the correction values in one of the following ways:

- Measure the RF output level at several frequency points and enter the value pairs manually in a table
- Connect an R&S NRP to the generator output signal and send the command [ :SOURce<hw> ] :CORRection:CSET:DATA [ :SENSor<ch> ] [ :POWer ] :SONCe to fill the table automatically.

Correction values can be stored in files with the predefined file extension \*.uco.

Refer to [Chapter 14.5.2, "Accessing Files in the Default or in a Specified Directory"](#), on page 443 for general information on file handling in the default and in a specific directory.

### Programming example

The examples in this section assume that:

- The files are stored in the default directory.
- \*RST does not affect data lists.

#### Example: Create a table with user-defined correction values for the RF level

The following example shows a command sequence to create and activate a list for assigning level correction values to arbitrary RF frequencies. Further hardware settings are not considered.

```
// Reset the instrument to start from an initial state
// Query the available user correction list files in the default directory
// Select a file or create a new one
// *****
*RST; *CLS
SOURcel:CORRection:CSET:CATalog?
// Response: shows the name of available user correction files (if applicable)
// Select a file
SOURcel:CORRection:CSET:SElect "/var/user/ucor1"
// Create a new file (if not existing)
SOURcel:CORRection:CSET:SElect "/var/user/ucor2"

// Enter the frequency/level value pairs in the table;
// existing data is overwritten
// Query the number of frequency/power entries in the selected list
SOURcel:CORRection:CSET:DATA:FREQuency 100MHz,110MHz,120MHz,130MHz,140MHz,150MHz
SOURcel:CORRection:CSET:DATA:POWer -10,-7.5,-5.0,-2.5,0,2.5
SOURcel:CORRection:CSET:DATA:FREQuency:POINTs?
// 6
SOURcel:CORRection:CSET:DATA:POWer:POINTs?
// 6

// Enable user correction mode and RF output
SOURcel:CORRection:STATe 1
OUTPut1:STATe ON
```

```
// Query the currently used correction value
SOURcel:CORRection:VALue?
// -2.5

// Delete a user correction file
SOURcel:CORRection:CSET:DELEte "/var/user/ucor1.uco"
```

### Example: Fill user correction data with sensor

The following example shows a command sequence to fill a user correction list automatically supported by a connected R&S NRP.

```
// Fill a user correction list with the level values
// measured by an R&S NRP,
// store the data in a file and enable user correction.

*RST; *CLS

SOURcel:CORRection:CSET:SElect "/var/user/Ucor1_AutoFill.uco"
SOURcel:CORRection:CSET:DATA:FREQuency 100MHz,110MHz,120MHz,130MHz,140MHz,150MHz
SOURcel:CORRection:ZERoing:STATe 1
SOURcel:CORRection:CSET:DATA:SENSor1:POWer:SONce
// Query the number of automatically filled correction level values
SOURcel:CORRection:CSET:DATA:POWer:POINTs?
// 6
SOURcel:CORRection:STATe 1

// Query the correction value at a certain frequency
FREQ 120000000
SOURcel:CORRection:VALue?
// -52.13
```

### Example: User correction data exchange

The following example shows a command sequence to export a user correction list (here the list created with the example before) into an ASCII file. Further hardware settings are not considered.

```
// Select a user correction file for exporting to file in ASCII format
// Set ASCII data parameters
// Set the ASCII file extension, the decimal separator
// and the column separator for the ASCII data
SOURcel:CORRection:DEXChange:AFILe:CATalog?
// my_ucor
SOURcel:CORRection:CSET:CATalog?
// ucor1,Ucor1_AutoFill
SOURcel:CORRection:CSET:SElect "/var/user/Ucor1_AutoFill.uco"
SOURcel:CORRection:DEXChange:AFILe:EXTension CSV
SOURcel:CORRection:DEXChange:AFILe:SEParator:DECimal DOT
SOURcel:CORRection:DEXChange:AFILe:SEParator:COLumn COMMa
```

```
// Select source and destination
SOURce1:CORRection:DEXChange:AFILe:SElect "/var/user/ucor2ASCII"

// Export the user correction data into the ASCII file
SOURce1:CORRection:DEXChange:MODE EXPort
SOURce1:CORRection:DEXChange:EXECute

// Query the available ASCII files with extension .csv
SOURce1:CORRection:DEXChange:AFILe:CATalog?
// ucor2ASCII,my_ucor

// Import a user correction ASCII file
SOURce1:CORRection:DEXChange:MODE IMPort
SOURce1:CORRection:DEXChange:AFILe:SElect "/var/user/my_ucor"
SOURce1:CORRection:DEXChange:EXECute
```

- [Correction Settings](#).....619
- [Correction Data Exchange](#).....622

### 14.16.3.1 Correction Settings

---

**[ :SOURce<hw>]:CORRection:CSET:DATA:FREQuency <Frequency>**

Enters the frequency value in the table selected with [\[ :SOURce<hw>\]:CORRection:CSET\[:SElect\]](#).

**Parameters:**

<Frequency>                      Frequency#1[, Frequency#2, ...]  
String of values with default unit Hz.

**Example:**                      See [Example "Create a table with user-defined correction values for the RF level"](#) on page 617 .

**Manual operation:**    See ["Edit List Mode Data"](#) on page 207

---

**[ :SOURce<hw>]:CORRection:CSET:DATA:POWer <Power>**

Enters the level values to the table selected with [\[ :SOURce<hw>\]:CORRection:CSET\[:SElect\]](#).

**Parameters:**

<Power>                            Power#1[, Power#2, ...]  
String of values with default unit dB.  
\*RST: 0

**Example:**                      See [Example "Create a table with user-defined correction values for the RF level"](#) on page 617 .

**Manual operation:**    See ["Edit List Mode Data"](#) on page 207

---

**[[:SOURce<hw>]:CORRection:CSET:DATA:FREQUency:POINts?  
[:SOURce<hw>]:CORRection:CSET:DATA:POWer:POINts?**

Queries the number of frequency/level values in the selected table.

**Return values:**

<Points>                    integer  
                                  Range:     0 to 10000  
                                  \*RST:     0

**Example:**                See [Example "Create a table with user-defined correction values for the RF level"](#) on page 617 .

**Usage:**                    Query only

---

**[[:SOURce<hw>]:CORRection:CSET:DATA[:SENSor<ch>][:POWer]:SONCe**

Fills the selected user correction table with the level values measured by the power sensor for the given frequencies.

To select the used power sensor set the suffix in key word `SENSe`.

**Example:**                See [Example "Fill user correction data with sensor"](#) on page 618.

**Usage:**                    Event

**Manual operation:**    See "[Fill User Correction Data with Sensor](#)" on page 225

---

**[[:SOURce<hw>]:CORRection:CSET[:SELEct] <Filename>**

Selects or creates a file for the user correction data.

If the file with the selected name does not exist, a new file is created.

**Parameters:**

<Filename>                string  
                                  Filename or complete file path; file extension can be omitted.

**Example:**                See [Example "Create a table with user-defined correction values for the RF level"](#) on page 617 .

**Manual operation:**    See "[UCOR Data](#)" on page 220

---

**[[:SOURce<hw>]:CORRection:VALue?**

Queries the current value for user correction.

**Return values:**

<Value>                    float  
                                  Range:     -100 to 100  
                                  Increment: 0.01  
                                  \*RST:     0



**Example:** See [Example "Create a table with user-defined correction values for the RF level"](#) on page 617 .

**Usage:** Query only

**Manual operation:** See ["User Correction"](#) on page 220

**[:SOURce<hw>]:CORRection:ZERoing:STATe <State>**

Activates the zeroing procedure before filling the user correction data acquired by a sensor.

**Parameters:**

<State> 0 | 1 | OFF | ON  
\*RST: 1

**Example:** See [Example "Fill user correction data with sensor"](#) on page 618.

**Manual operation:** See [" Fill User Correction Data with Sensor"](#) on page 225

**[:SOURce<hw>]:CORRection:CSET:DATA[:SENSor<ch>][:POWer]:SONCe**

Fills the selected user correction list with the level values measured by the power sensor for the given frequencies.

**Suffix:**

SENSor<ch> Defines the used power sensor, i.e. the sensor whose values are used.

**Example:** See [Example "Fill user correction data with sensor"](#) on page 618.

**Usage:** Event

**[:SOURce<hw>]:CORRection[::STATe] <State>**

Activates user correction with the currently selected table.

**Parameters:**

<State> 0 | 1 | OFF | ON  
\*RST: 0

**Example:** See [Example "Create a table with user-defined correction values for the RF level"](#) on page 617 .

**Manual operation:** See ["State"](#) on page 220

**[:SOURce]:CORRection:CSET:CATalog?**

Queries a list of available user correction tables.

**Return values:**

<Catalog> string  
List of list filenames, separated by commas

**Example:** See [Example "Create a table with user-defined correction values for the RF level"](#) on page 617 .

**Usage:** Query only

**Manual operation:** See ["UCOR Data"](#) on page 220

**[:SOURce]:CORRection:CSET:DELeTe** <Filename>

Deletes the specified user correction list file.

**Setting parameters:**

<Filename> string  
Filename or complete file path; file extension is optional.

**Example:** See [Example "Create a table with user-defined correction values for the RF level"](#) on page 617 .

**Usage:** Setting only

**Manual operation:** See ["UCOR Data"](#) on page 220

### 14.16.3.2 Correction Data Exchange

With the following commands, you can configure user correction lists and export or import them accordingly.

**[:SOURce<hw>]:CORRection:DEXChange:AFILe:CATalog?**

Queries the available ASCII files for export or import of user correction data in the current or specified directory.

**Return values:**

<Catalog> string  
List of ASCII files \*.txt or \*.csv, separated by commas.

**Example:** See [Example "Create a table with user-defined correction values for the RF level"](#) on page 617 .

**Usage:** Query only

**Manual operation:** See ["Select \(ASCII\) Source/Select \(ASCII\) Destination"](#) on page 109

**[:SOURce<hw>]:CORRection:DEXChange:AFILe:EXTension** <Extension>

Determines the extension of the ASCII files for file import or export, or to query existing files.

**Parameters:**

<Extension>            TXT | CSV  
 \*RST:                TXT

**Example:**            See [Example "User correction data exchange"](#) on page 618 .

**Manual operation:** See ["ASCII File Settings"](#) on page 108

**[[:SOURce<hw>]:CORRection:DEXChange:AFILe:SElect <Filename>**

Selects the ASCII file to be imported or exported.

**Parameters:**

<Filename>            string  
 Filename or complete file path; file extension can be omitted.

**Example:**            See [Example "User correction data exchange"](#) on page 618 .

**Manual operation:** See ["Select \(ASCII\) Source/Select \(ASCII\) Destination"](#) on page 109

**[[:SOURce<hw>]:CORRection:DEXChange:AFILe:SEParator:COLumn <Column>**

Selects the separator between the frequency and level column of the ASCII table.

**Parameters:**

<Column>            TABulator | SEMicolon | COMMa | SPACe  
 \*RST:                COMMa

**Example:**            See [Example "User correction data exchange"](#) on page 618 .

**Manual operation:** See ["ASCII File Settings"](#) on page 108

**[[:SOURce<hw>]:CORRection:DEXChange:AFILe:SEParator:DECimal <Decimal>**

Sets the decimal separator used in the ASCII data between '.' (decimal point) and ',' (comma) with floating-point numerals.

**Parameters:**

<Decimal>            DOT | COMMa  
 \*RST:                DOT

**Example:**            See [Example "User correction data exchange"](#) on page 618 .

**Manual operation:** See ["ASCII File Settings"](#) on page 108

**[[:SOURce<hw>]:CORRection:DEXChange:EXECute**

Executes the import or export of the selected correction list, according to the previously set transfer direction with command [\[:SOURce<hw>\]:CORRection:DEXChange:MODE](#).

**Example:**            See [Example "User correction data exchange"](#) on page 618 .

**Usage:** Event

**Manual operation:** See ["Import / Export"](#) on page 109

**[ :SOURce<hw>]:CORRection:DEXChange:MODE <Mode>**

Determines import or export of a user correction list.

Specify the source or destination file with the command `[ :SOURce<hw> ] :CORRection:DEXChange:SElect`.

**Parameters:**

<Mode>                    IMPort | EXPort  
\*RST:                    IMPort

**Example:** See [Example "User correction data exchange"](#) on page 618 .

**Manual operation:** See [" Mode "](#) on page 108

**[ :SOURce<hw>]:CORRection:DEXChange:SElect <Filename>**

Selects the ASCII file for import or export, containing a user correction list.

**Parameters:**

<Filename>                string  
Filename or complete file path; file extension can be omitted.

**Example:** See [Example "User correction data exchange"](#) on page 618 .

**Manual operation:** See ["Select Source/Select ASCII Destination"](#) on page 109

## 14.16.4 SOURce:FREQuency Subsystem

The `SOURce:FREQuency` subsystem contains the commands used to define the frequency settings for the RF sources and sweeps.

**Example: Frequency configuration**

```
SOURce1:FREQuency:MODE CW
SOURce1:FREQuency:CW 6000000000
SOURce1:FREQuency:OFFSet 2000000000
SOURce1:FREQuency:MULTIplier 1.5
SOURce1:FREQuency:CW?
// 11000000000

// SOURce1:FREQuency:STEP:MODE USER
// SOURce1:FREQuency:STEP:INCRement 1000000
// SOURce1:FREQuency:CW UP

SOURce1:PHASe 2
SOURce1:PHASe:REFerence
```

**Example: Setting a phase continuous frequency range**

```

SOURce1:FREQuency:CW 502000000
SOURce1:FREQuency:PHASE:MODE NARR
SOURce1:FREQuency:PHASE:CONTInuous:STATe 1
*****
// Query the frequency range
SOURce1:FREQuency:PHASE:CONTInuous:LOW?
// Response: 494062500
SOURce1:FREQuency:PHASE:CONTInuous:HIGh?
// Response: 503750000
*****
// Vary the frequency. Within the specified range the signal is phase continuous.
SOURce1:FREQuency:CW 499000000
SOURce1:FREQuency:CW 500000000
SOURce1:FREQuency:CW 501000000
SOURce1:FREQuency:CW 503000000

```

<a href="#">[:SOURce&lt;hw&gt;]:FREQuency:MODE.....</a>	625
<a href="#">[:SOURce&lt;hw&gt;]:FREQuency[:CW FIXed].....</a>	626
<a href="#">[:SOURce&lt;hw&gt;]:FREQuency[:CW FIXed]:RCL.....</a>	627
<a href="#">[:SOURce&lt;hw&gt;]:FREQuency:MANual.....</a>	627
<a href="#">[:SOURce&lt;hw&gt;]:FREQuency:MULTIplier.....</a>	628
<a href="#">[:SOURce&lt;hw&gt;]:FREQuency:OFFSet.....</a>	628
<a href="#">[:SOURce&lt;hw&gt;]:FREQuency:CENTer.....</a>	629
<a href="#">[:SOURce&lt;hw&gt;]:FREQuency:SPAN.....</a>	629
<a href="#">[:SOURce&lt;hw&gt;]:FREQuency:STARt.....</a>	629
<a href="#">[:SOURce&lt;hw&gt;]:FREQuency:STOP.....</a>	630
<a href="#">[:SOURce&lt;hw&gt;]:FREQuency:STEP:MODE.....</a>	630
<a href="#">[:SOURce&lt;hw&gt;]:FREQuency:STEP[:INCRement].....</a>	630
<a href="#">[:SOURce&lt;hw&gt;]:FREQuency:PLL:MODE.....</a>	631

**[:SOURce<hw>]:FREQuency:MODE <Mode>**

Sets the frequency mode for generating the RF output signal. The selected mode determines the parameters to be used for further frequency settings.

**Parameters:**

<Mode> CW | FIXed | SWEep | LIST | COMBined

**CW|FIXed**

Sets the fixed frequency mode. CW and FIXed are synonyms. The instrument operates at a defined frequency, set with command `[:SOURce<hw>]:FREQuency[:CW|FIXed]`.

**SWEep**

Sets sweep mode.

The instrument processes frequency (and level) settings in defined sweep steps.

Set the range and current frequency with the commands:

[ :SOURce<hw> ] :FREQuency:START on page 629 and [ :SOURce<hw> ] :FREQuency:STOP on page 630,  
 [ :SOURce<hw> ] :FREQuency:CENTer on page 629,  
 [ :SOURce<hw> ] :FREQuency:SPAN on page 629,  
 [ :SOURce<hw> ] :FREQuency:MANual on page 627

**LIST**

Sets list mode.

The instrument processes frequency and level settings by means of values loaded from a list.

To configure list mode settings, use the commands of the [Chapter 14.16.7, "SOURce:LIST Subsystem"](#), on page 645.

**COMBined**

Sets the combined RF frequency / level sweep mode.

The instrument processes frequency and level settings in defined sweep steps.

Set the range and current frequency with the commands:

[ :SOURce<hw> ] :COMBined:FREQuency:START on page 685 and [ :SOURce<hw> ] :COMBined:FREQuency:STOP on page 685,  
 [ :SOURce<hw> ] :COMBined:POWer:START on page 685 and [ :SOURce<hw> ] :COMBined:POWer:STOP on page 686

\*RST: CW

**Example:** See [Example "Frequency configuration"](#) on page 624, and [Example "Setup an RF frequency or power sweep"](#) on page 676

**Manual operation:** See ["State \(RF frequency sweep\)"](#) on page 186

---

**[ :SOURce<hw> ] :FREQuency[:CW|FIXed] <Fixed>**

Sets the frequency of the RF output signal in the selected path.

The effect depends on the selected mode:

- In CW mode ([FREQ:MODE CW | FIXed](#)), the instrument operates at a fixed frequency.
- In sweep mode ([FREQ:MODE SWE](#)), the value applies to the sweep frequency. The instrument processes the frequency settings in defined sweep steps.
- In user mode ([FREQ:STEP:MODE USER](#)), you can vary the current frequency step by step.

**Parameters:**

<Fixed> float

The following settings influence the value range:

An offset set with the command `[ :SOURce<hw> ] :FREQuency:OFFSet`

#### Numerical value

Sets the frequency in CW and sweep mode

#### UP|DOWN

Varies the frequency step by step in user mode.

The frequency is increased or decreased by the value set with the command `[ :SOURce<hw> ] :FREQuency:STEP [ :INCRement ]`.

Range: (RFmin + OFFSet) to (RFmax + OFFSet)

\*RST: 100 MHz

**Example:** See [Example "Frequency configuration"](#) on page 624

**Example:** See [Example "Setup an RF frequency or power sweep"](#) on page 676

**Options:** RFmax depends on the installed options, for example 3 GHz with R&S SMAB-B103

**Manual operation:** See ["Frequency"](#) on page 72

#### `[ :SOURce<hw> ] :FREQuency [ :CW | FIXed ] :RCL <Rcl>`

Set whether the RF frequency value is retained or taken from a loaded instrument configuration, when you recall instrument settings with command `*RCL`.

#### Parameters:

<Rcl> INCLude | EXCLude

#### INCLude

Takes the frequency value of the loaded settings.

#### EXCLude

Retains the current frequency when an instrument configuration is loaded.

\*RST: INCLude

**Example:** `SOURce1:FREQuency:CW:RCL INCLude`

**Manual operation:** See ["Exclude Frequency"](#) on page 313

#### `[ :SOURce<hw> ] :FREQuency:MANual <Manual>`

Sets the frequency and triggers a sweep step manually if `SWEep:MODE MAN`.

#### Parameters:

<Manual> float

You can select any frequency within the setting range, where:

START is set with `[ :SOURce<hw> ] :FREQuency:START`

STOP is set with `[ :SOURce<hw> ] :FREQuency:STOP`

OFFSet is set with `[ :SOURce<hw> ] :FREQuency:OFFSet`

Range: (START + OFFSet) to (STOP + OFFSet)  
 Increment: 0.01Hz  
 \*RST: 100 MHz  
 Default unit: Hz

**Example:** See [Example "Setup an RF frequency or power sweep"](#) on page 676

**Manual operation:** See ["Current Frequency"](#) on page 187

#### **[:SOURce<hw>]:FREQUENCY:MULTIPLIER <Multiplier>**

Sets the multiplication factor  $N_{\text{FREQ:MULT}}$  of a subsequent downstream instrument.

The parameters offset  $f_{\text{FREQ:OFFSer}}$  and multiplier  $N_{\text{FREQ:MULT}}$  affect the frequency value set with the command [FREQ](#).

The query [FREQ?](#) returns the value corresponding to the formula:

$$f_{\text{FREQ}} = f_{\text{RFout}} * N_{\text{FREQ:MULT}} + f_{\text{FREQ:OFFSer}}$$

See ["RF frequency and level display with a downstream instrument"](#) on page 68.

#### **Parameters:**

<Multiplier> float  
 Range: -10000 to 10000  
 Increment: 0.001  
 \*RST: 1

**Example:** See [Example "Frequency configuration"](#) on page 624

**Manual operation:** See ["Multiplier"](#) on page 73

#### **[:SOURce<hw>]:FREQUENCY:OFFSET <Offset>**

Sets the frequency offset  $f_{\text{FREQ:OFFSet}}$  of a downstream instrument.

The parameters offset  $f_{\text{FREQ:OFFSer}}$  and multiplier  $N_{\text{FREQ:MULT}}$  affect the frequency value set with the command [FREQ](#).

The query [FREQ?](#) returns the value corresponding to the formula:

$$f_{\text{FREQ}} = f_{\text{RFout}} * N_{\text{FREQ:MULT}} + f_{\text{FREQ:OFFSer}}$$

See ["RF frequency and level display with a downstream instrument"](#) on page 68.

**Note:** The offset also affects RF frequency sweep.

#### **Parameters:**

<Offset> float  
 Increment: 0.01  
 \*RST: 0

**Example:** See [Example "Frequency configuration"](#) on page 624

**Manual operation:** See ["Offset"](#) on page 73



---

**[:SOURce<hw>]:FREQUENCY:CENTer <Center>**

Sets the center frequency of the sweep.

See [Chapter 7.2.1, "Correlating Parameters in Sweep Mode"](#), on page 179.

**Parameters:**

<Center> float  
Range: 300 kHz to RFmax  
Increment: 0.01 Hz  
\*RST: 300E6  
Default unit: Hz

**Example:** See [Example "Setup an RF frequency or power sweep"](#) on page 676

**Manual operation:** See "[Center Frequency](#)" on page 192

---

**[:SOURce<hw>]:FREQUENCY:SPAN <Span>**

Sets the span of the frequency sweep range.

See [Chapter 7.2.1, "Correlating Parameters in Sweep Mode"](#), on page 179.

**Parameters:**

<Span> float  
Full frequency range  
Increment: 0.01  
\*RST: 400E6

**Example:** See [Example "Setup an RF frequency or power sweep"](#) on page 676

**Manual operation:** See "[Span](#)" on page 193

---

**[:SOURce<hw>]:FREQUENCY:STARt <Start>**

Sets the start frequency for the RF sweep.

See [Chapter 7.2.1, "Correlating Parameters in Sweep Mode"](#), on page 179.

**Parameters:**

<Start> float  
Range: 300kHz to RFmax  
Increment: 0.01Hz  
\*RST: 100 MHz

**Example:** See [Example "Setup an RF frequency or power sweep"](#) on page 676

**Manual operation:** See "[Start Frequency/Stop Frequency](#)" on page 192

---

**[:SOURce<hw>]:FREQUENCY:STOP <Stop>**

Sets the stop frequency range for the RF sweep.

See [Chapter 7.2.1, "Correlating Parameters in Sweep Mode"](#), on page 179.

**Parameters:**

<Stop> float  
 Range: 300kHz to RFmax  
 Increment: 0.01Hz  
 \*RST: 500 MHz  
 Default unit: Hz

**Example:** See [Example "Setup an RF frequency or power sweep"](#) on page 676

**Manual operation:** See "[Start Frequency/Stop Frequency](#)" on page 192

---

**[:SOURce<hw>]:FREQUENCY:STEP:MODE <Mode>**

Defines the type of step size to vary the RF frequency at discrete steps with the commands [FREQ UP](#) or [FREQ DOWN](#).

**Parameters:**

<Mode> DECimal | USER  
**DECimal**  
 Increases or decreases the level in steps of ten.  
**USER**  
 Increases or decreases the level in increments, set with the command [FREQ:STEP\[:INCR\]](#).  
 \*RST: DECimal

**Example:**

```
// increasing the RF frequency with a step size of 50 KHz
SOURce1:FREQUENCY:STEP 50E3
SOURce1:FREQUENCY:STEP:MODE USER
SOURce1:FREQUENCY:CW UP
```

**Manual operation:** See "[Variation Active](#)" on page 73

---

**[:SOURce<hw>]:FREQUENCY:STEP[:INCRement] <Increment>**

Sets the step width.

You can use this value to vary the RF frequency with command [FREQ UP](#) or [FREQ DOWN](#), if you have activated [FREQ:STEP:MODE USER](#).

**Note:** This value also applies to the step width of the rotary knob on the instrument and, in user-defined step mode, increases or decreases the frequency.

**Parameters:**

<Increment> float  
 Range: 0 Hz to RFmax - 100 kHz  
 Increment: 0.01 Hz  
 \*RST: 1E6

**Example:** See [Example "Frequency configuration"](#) on page 624

**Manual operation:** See ["Variation Step"](#) on page 73

**[ :SOURce<hw>]:FREQuency:PLL:MODE <Mode>**

Selects the PLL (Phase Locked Loop) bandwidth of the main synthesizer.

**Parameters:**

<Mode> NORMal | NARRow  
**NORMal**  
 Maximum modulation bandwidth and FM/PhiM deviation.  
**NARRow**  
 Narrow PLL bandwidth  
 \*RST: NORMal

**Example:** SOURce:FREQuency:PLL:MODE NORMal

**Manual operation:** See ["Main PLL Bandwidth"](#) on page 73

## 14.16.5 SOURce:INPut Subsystem

The SOURce:INPut subsystem contains the commands for configuring the inputs for external modulation signals. The instrument trigger setting influences all sweeps and is effective in the List mode (Instrument Trigger).

[\[:SOURce<hw>\]:INPut:MODext:COUPling<ch>](#) ..... 631  
[\[:SOURce<hw>\]:INPut:MODext:IMPedance<ch>](#) ..... 632  
[\[:SOURce\]:INPut:TRIGger:SLOPe](#) ..... 632

**[ :SOURce<hw>]:INPut:MODext:COUPling<ch> <Coupling>**

Selects the coupling mode for an externally applied modulation signal.

**Parameters:**

<Coupling> AC | DC  
**AC**  
 Passes the AC signal component of the modulation signal.  
**DC**  
 Passes the modulation signal with both components, AC and DC.  
 For active external exponential AM, automatically sets [\[:SOURce<hw>\]:INPut:MODext:COUPling<ch>](#)DC.  
 \*RST: AC

**Example:** `INP:MOD:COUP AC`  
Selects the coupling mode AC for an externally applied modulation signal.

**Manual operation:** See "[Coupling \(AC/DC\)](#)" on page 117

**[:SOURce<hw>]:INPut:MODext:IMPedance<ch> <Impedance>**

Sets the impedance for the externally supplied modulation signal.

**Parameters:**

<Impedance>            G50 | G600 | HIGH  
G50 = 50 Ohm to ground  
G600 = 600 Ohm to ground  
HIGH = 100 kOhm to ground  
\*RST:            HIGH

**Example:** See `[ :SOURce<hw> ] :INPut:MODext:COUPling<ch>` on page 631.

**Manual operation:** See "[Impedance](#)" on page 117

**[:SOURce]:INPut:TRIGger:SLOPe <Slope>**

Sets the polarity of the active slope of an applied instrument trigger.

**Parameters:**

<Slope>            NEGative | POSitive  
\*RST:            POSitive

**Example:** `INP:TRIG:SLOP NEG`  
Activates the falling slope of the external trigger signal at the trigger input.

**Manual operation:** See "[Trigger Slope](#)" on page 191

## 14.16.6 SOURce:LFOutput Subsystem

The `SOURce:LFOutput` subsystem contains the commands for setting the LF signal source in CW and Sweep mode and for analog modulation.

**Example: Setup an LF sweep**

The following example shows a command sequence to set up an LF sweep.

```
// Reset the instrument to start from an initial state
*RST; *CLS

// Set the trigger mode, the sweep mode and the sweep range
TRIGger1:LFFSweep:SOURce SINGLE
SOURce1:LFOutput1:SWEep:FREQuency:MODE AUTO
```

```

SOURcel:LFOOutput1:FREQuency:START 1 kHz
SOURcel:LFOOutput1:FREQuency:STOP 7 kHz

// Select linear spacing
// Select the waveform shape for the frequency sweep cycle
// Set the step width and the dwell time.
SOURcel:LFOOutput1:SWEep:FREQuency:SPACing LINear
SOURcel:LFOOutput1:SWEep:FREQuency:SHAPE SAWtooth
SOURcel:LFOOutput1:SWEep:FREQuency:STEP:LINear 100 Hz
SOURcel:LFOOutput1:SWEep:FREQuency:DWELL 150 ms
// Alternatively to the step width set the number of steps
SOURcel:LFOOutput1:SWEep:FREQuency:POINTs 61

// Activate change to start frequency while waiting for next trigger
// Prerequisites: sweep mode single and sweep waveform sawtooth
SOURcel:LFOOutput:SWEep:FREQuency:RETRace 1

// Activate the LF frequency sweep
SOURcel:LFOOutput:FREQuency:MODE SWE

// Trigger the sweep(depending on the set mode) and query the status
// Perform a one-off LF sweep
SOURcel:LFOOutput1:SWEep:FREQuency:EXECute
SOURcel:LFOOutput1:SWEep:FREQuency:RUNning?
// 1
// the sweep is running

// *****
// For manual step LF sweep use the following commands
*RST; *CLS
SOURcel:LFOOutput:SWEep:FREQuency:MODE MANual
// Activate the LF frequency sweep
SOURcel:LFOOutput:FREQuency:MODE SWEep
// Activate LF Output1.
SOURcel:LFOOutput1:STATE 1
// Input the frequency manually for each step
SOURcel:LFOOutput1:FREQuency:MANual 2 kHz
SOURcel:LFOOutput1:FREQuency:MANual 2.1 kHz
// Alternatively use UP or DOWN parameter with set step width.
SOURcel:LFOOutput1:SWEep:FREQuency:STEP:LINear 500 Hz
SOURcel:LFOOutput1:FREQuency:MANual UP

```

### Example: Configuring the LF generator

The following is a simple example on how to configure the LF generator and output the generated signal.

```

// configure the signal of the LF1 generator
SOURcel:LFOOutput1:SHAPE SQU
SOURcel:LFOOutput1:SHAPE:PULSE:PERiod 0.001
SOURcel:LFOOutput1:SHAPE:PULSE:WIDTh 0.0005

```

```

SOURce1:LFOutput1:SHAPE:PULSE:DCYCLE 0.5
// configure the signal of the LF1 generator
SOURce1:LFOutput2:SHAPE SINE
SOURce1:LFOutput2:FREQUENCY 1000000
SOURce1:LFOutput2:PERIOD?
// 0.000001

// changing the LF signal shape
// SOURce1:LFOutput2:SHAPE TRAP
// SOURce1:LFOutput2:SHAPE:PULSE:PERIOD 0.2
// SOURce1:LFOutput2:SHAPE:TRAPeZE:RISE 0.0001
// SOURce1:LFOutput2:SHAPE:TRAPeZE:FALL 0.001
// SOURce1:LFOutput2:SHAPE:TRAPeZE:FALL 0.0001
// SOURce1:LFOutput2:SHAPE:TRAPeZE:HIGh 0.0005
// SOURce1:LFOutput2:SHAPE TRI
// SOURce1:LFOutput2:SHAPE:PULSE:PERIOD 0.1
// SOURce1:LFOutput2:SHAPE:TRIangle:RISE 0.0001

// activate the LF output and select the LF1 as signal source
// configure the LF output signal
SOURce1:LFOutput1:FREQUENCY:MODE CW
SOURce1:LFOutput1:STATE 1
SOURce1:LFOutput1:SOURce LF1
SOURce1:LFOutput1:INTERNAL:VOLTage 1
SOURce1:LFOutput1:OFFSET 0.001

```

- [LF Generator Settings](#).....634
- [LF Sweep Settings](#).....641

#### 14.16.6.1 LF Generator Settings

With the commands described in this section, you can configure the LF signal source.

<a href="#">[:SOURce]:LFOutput&lt;ch&gt;:BANDwidth?</a> .....	635
<a href="#">[:SOURce]:LFOutput&lt;ch&gt;:FREQUENCY</a> .....	635
<a href="#">[:SOURce&lt;hw&gt;]:LFOutput&lt;ch&gt;:PERIOD?</a> .....	635
<a href="#">[:SOURce&lt;hw&gt;]:LFOutput:FREQUENCY:MANual</a> .....	636
<a href="#">[:SOURce&lt;hw&gt;]:LFOutput:FREQUENCY:MODE</a> .....	636
<a href="#">[:SOURce&lt;hw&gt;]:LFOutput:FREQUENCY:STOP</a> .....	637
<a href="#">[:SOURce&lt;hw&gt;]:LFOutput:FREQUENCY:START</a> .....	637
<a href="#">[:SOURce]:LFOutput&lt;ch&gt;[:STATE]</a> .....	637
<a href="#">[:SOURce]:LFOutput&lt;ch&gt;:INTERNAL:VOLTage</a> .....	637
<a href="#">[:SOURce]:LFOutput:OFFSET</a> .....	638
<a href="#">[:SOURce]:LFOutput&lt;ch&gt;:SOURce</a> .....	638
<a href="#">[:SOURce]:LFOutput&lt;ch&gt;:SOURce:PATH</a> .....	638
<a href="#">[:SOURce]:LFOutput:VOLTage</a> .....	638
<a href="#">[:SOURce&lt;hw&gt;]:LFOutput&lt;ch&gt;:SHAPE</a> .....	639
<a href="#">[:SOURce&lt;hw&gt;]:LFOutput&lt;ch&gt;:SHAPE:PULSE:DCYCLE</a> .....	639
<a href="#">[:SOURce&lt;hw&gt;]:LFOutput&lt;ch&gt;:SHAPE:PULSE:PERIOD</a> .....	639
<a href="#">[:SOURce&lt;hw&gt;]:LFOutput&lt;ch&gt;:SHAPE:PULSE:WIDTH</a> .....	640

<code>[ :SOURce&lt;hw&gt;]:LFOutput&lt;ch&gt;:SHAPE:TRAPeZe:FALL</code> .....	640
<code>[ :SOURce&lt;hw&gt;]:LFOutput&lt;ch&gt;:SHAPE:TRAPeZe:HIGH</code> .....	640
<code>[ :SOURce&lt;hw&gt;]:LFOutput&lt;ch&gt;:SHAPE:TRAPeZe:PERiod</code> .....	640
<code>[ :SOURce&lt;hw&gt;]:LFOutput&lt;ch&gt;:SHAPE:TRAPeZe:RISE</code> .....	641
<code>[ :SOURce&lt;hw&gt;]:LFOutput&lt;ch&gt;:SHAPE:TRlangle:PERiod</code> .....	641
<code>[ :SOURce&lt;hw&gt;]:LFOutput&lt;ch&gt;:SHAPE:TRlangle:RISE</code> .....	641

---

### `[ :SOURce]:LFOutput<ch>:BANDwidth?`

Queries the bandwidth of the external LF signal.

#### Return values:

<Bandwidth>            BW0M2 | BW10m  
 \*RST:                BW10m

#### Example:

```
LFO:BAND?
// BW10m
// the bandwidth of the externally supplied LF signal is 10 MHz
```

**Usage:**                Query only

**Manual operation:**   See "[Bandwidth](#)" on page 117

---

### `[ :SOURce]:LFOutput<ch>:FREQuency <Frequency>`

Sets the frequency of the LF signal in `[ :SOURce<hw>]:LFOutput:FREQuency:MODE` CW | FIXed mode.

#### Note

- If signal source "Internal" is set, the instrument performs the analog modulations (AM/FM/PhiM/PM) with this frequency.
- In sweep mode (`[ :SOURce<hw>]:LFOutput:FREQuency:MODE` SWE), the frequency is coupled with the sweep frequency.

#### Parameters:

<Frequency>            float  
 Range:                depends on the installed options  
 Increment:            0.01  
 \*RST:                 1000  
 Default unit:         Hz

#### Example:

```
SOURce1:LFOutput1:FREQuency 5 kHz
// sets the LF frequency
```

**Manual operation:**   See "[Frequency](#)" on page 115

---

### `[ :SOURce<hw>]:LFOutput<ch>:PERiod?`

Queries the repetition frequency of the sine signal.

**Return values:**

<LfSinePeriod> float  
 Range: 1E-6 to 100  
 Increment: 10E-9  
 \*RST: 0.001  
 Default unit: s

**Example:** See [Example "Configuring the LF generator"](#) on page 633.

**Usage:** Query only

**[ :SOURce<hw>]:LFOutput:FREQuency:MANual <Manual>**

Sets the frequency of the subsequent sweep step if `LFO:SWE:MODE MAN`.

Use a separate command for each sweep step.

**Parameters:**

<Manual> float  
 You can select any value within the setting range, where:  
 START is set with `[ :SOURce<hw>]:LFOutput:FREQuency:START`  
 STOP is set with `[ :SOURce<hw>]:LFOutput:FREQuency:STOP`  
 Range: START to STOP  
 Increment: 0.1  
 \*RST: 1000

**Example:** See [Example "Setup an LF sweep"](#) on page 632.

**Manual operation:** See ["Current Frequency"](#) on page 187

**[ :SOURce<hw>]:LFOutput:FREQuency:MODE <Mode>**

Sets the mode for the output of the LF generator frequency, and determines the commands to be used for frequency settings.

**Parameters:**

<Mode> CW | FIXed | SWEep  
**CW|FIXed**  
 Sets the fixed-frequency mode. CW and FIXed are synonyms.  
 To set the output frequency, use command `[ :SOURce]:LFOutput<ch>:FREQuency`  
**SWEep**  
 Sets sweep mode.  
 To set the frequency, use the commands:  
`[ :SOURce<hw>]:LFOutput:FREQuency:START` and `[ :SOURce<hw>]:LFOutput:FREQuency:STOP`  
 Or `[ :SOURce<hw>]:LFOutput:FREQuency:MANual`  
 \*RST: CW



**Example:** See [Example "Setup an LF sweep"](#) on page 632.

**Manual operation:** See ["State \(LF frequency sweep\)"](#) on page 113

```
[ :SOURce<hw>]:LFOutput:FREQuency:STOP <Stop>
[ :SOURce<hw>]:LFOutput:FREQuency:START <Start>
```

Sets the start/stop frequency for `[ :SOURce<hw>]:LFOutput:FREQuency:MODE` `SWEep`.

**Parameters:**

<Start> float  
 Range: 0.1 Hz to 1 MHz  
 Increment: 0.1  
 \*RST: 1 KHz

**Example:** See [Example "Setup an LF sweep"](#) on page 632.

**Manual operation:** See [" Start Frequency/Stop Frequency "](#) on page 192

```
[ :SOURce]:LFOutput<ch>[:STATe] <State>
```

Activates LF signal output.

**Parameters:**

<State> 0 | 1 | OFF | ON  
 \*RST: 0

**Example:** See [Example "Configuring the LF generator"](#) on page 633.

**Manual operation:** See ["State"](#) on page 119

```
[ :SOURce]:LFOutput<ch>:INTernal:VOLTagE <Voltage>
```

Sets the output voltage for the LF generators.

The sum of both values must not exceed the overall output voltage, set with command `[ :SOURce]:LFOutput:VOLTagE`.

**Suffix:**

<ch> [1]2  
 LF1 and LF2

**Parameters:**

<Voltage> float  
 Range: 0 to 4  
 Increment: 0.001  
 \*RST: 1

**Example:** See [Example "Configuring the LF generator"](#) on page 633.

**Manual operation:** See ["Output Voltage"](#) on page 120

---

**[[:SOURce]:LFOutput:OFFSet <Offset>**

Sets a DC offset at the LF Output.

**Parameters:**

<Offset>	float
Range:	depends on lfo voltage
Increment:	0.001
*RST:	0

**Example:** See [Example "Configuring the LF generator"](#) on page 633.

**Manual operation:** See ["DC-Offset"](#) on page 120

---

**[[:SOURce]:LFOutput<ch>:SOURce <Source>**

Determines the LF signal to be synchronized, when monitoring is enabled.

**Parameters:**

<Source>	LF1   LF2   NOISe   AM   FMPM   EXT1     EXT2
<b>LF1 LF2</b>	Selects an internally generated LF signal.
<b>NOISe</b>	Selects an internally generated noise signal.
<b>EXT1 EXT2</b>	Selects an externally supplied LF signal
<b>AM</b>	Selects the AM signal.
<b>FMPM</b>	Selects the signal also used by the frequency or phase modulations.
*RST:	LF1

**Example:** See [Example "Configuring the LF generator"](#) on page 633.

**Manual operation:** See ["Source"](#) on page 120

---

**[[:SOURce]:LFOutput<ch>:SOURce:PATH <SourPath>**

Determines the path of the LF output source.

**Parameters:**

<SourPath>	A   B
*RST:	A

**Example:** LFO:SOUR:PATH?  
Queries the currently set path for the LF output signal source.

---

**[[:SOURce]:LFOutput:VOLTage <Voltage>**

Sets the voltage of the LF output.

**Parameters:**

<Voltage> float  
 Range: dynamic (see data sheet)  
 Increment: 0.001  
 \*RST: 1

**Example:**

SOURce:LFOutput:VOLTage 1.5

**[[:SOURce<hw>]:LFOutput<ch>:SHAPE <Shape>**

Selects the waveform shape of the LF signal.

**Parameters:**

<Shape> SINE | SQUare | PULSe | TRIangle | TRAPeze  
 \*RST: SINE

**Example:**

See [Example "Configuring the LF generator"](#) on page 633.

**Options:**

TRIangle|TRAPeze require R&S SMAB-K24

**Manual operation:**

See ["Shape"](#) on page 113

**[[:SOURce<hw>]:LFOutput<ch>:SHAPE:PULSe:DCYCLE <DCycle>**

Sets the duty cycle for the shape pulse.

**Parameters:**

<DCycle> float  
 Range: 1E-6 to 100  
 Increment: 1E-6  
 \*RST: 50  
 Default unit: PCT

**Example:**

See [Example "Configuring the LF generator"](#) on page 633.

**Manual operation:**

See ["Pulse Duty Cycle"](#) on page 115

**[[:SOURce<hw>]:LFOutput<ch>:SHAPE:PULSe:PERiod <Period>**

Sets the period of the generated pulse. The period determines the repetition frequency of the internal signal.

**Parameters:**

<Period> float  
 Range: 1E-6 to 100  
 Increment: 1E-8  
 \*RST: 1E-3

**Example:**

See [Example "Configuring the LF generator"](#) on page 633.

**Manual operation:**

See ["Period"](#) on page 115

---

**[:SOURce<hw>]:LFOutput<ch>:SHAPE:PULSE:WIDTH <Width>**

Sets the pulse width of the generated pulse.

**Parameters:**

<Width>	float
	Range: 1E-6 to 100
	Increment: 1E-8
	*RST: 5E-4

**Example:** See [Example "Configuring the LF generator"](#) on page 633.

**Manual operation:** See ["Pulse Width"](#) on page 115

---

**[:SOURce<hw>]:LFOutput<ch>:SHAPE:TRAPeZe:FALL <Fall>**

Selects the fall time for the trapezoid shape of the LF generator.

**Parameters:**

<Fall>	float
	Range: 1E-6 to 100
	Increment: 10E-9
	*RST: 250E-6

**Example:** See [Example "Configuring the LF generator"](#) on page 633.

**Manual operation:** See ["Trapezoid Rise / Fall"](#) on page 116

---

**[:SOURce<hw>]:LFOutput<ch>:SHAPE:TRAPeZe:HIGH <High>**

Sets the high time for the trapezoid signal of the LF generator.

**Parameters:**

<High>	float
	Range: 1E-6 to 100
	Increment: 10E-9
	*RST: 250E-6

**Example:** See [Example "Configuring the LF generator"](#) on page 633.

**Manual operation:** See ["Trapezoid High"](#) on page 116

---

**[:SOURce<hw>]:LFOutput<ch>:SHAPE:TRAPeZe:PERiod <Period>**

Sets the period of the generated trapezoid shape. The period determines the repetition frequency of the internal signal.

**Parameters:**

<Period>	float
	Range: 1E-6 to 100
	Increment: 1E-8
	*RST: 1E-3

**Example:** See [Example "Configuring the LF generator"](#) on page 633.

**Manual operation:** See ["Period"](#) on page 115

**[:SOURce<hw>]:LFOutput<ch>:SHAPE:TRAPeZe:RISE <Rise>**

Selects the rise time for the trapezoid shape of the LF generator.

**Parameters:**

<Rise>	float
	Range: 1E-6 to 100
	Increment: 10E-9
	*RST: 250E-6

**Example:** See [Example "Configuring the LF generator"](#) on page 633.

**Manual operation:** See ["Trapezoid Rise / Fall"](#) on page 116

**[:SOURce<hw>]:LFOutput<ch>:SHAPE:TRlangle:PERiod <Period>**

Sets the period of the generated pulse. The period determines the repetition frequency of the internal signal.

**Parameters:**

<Period>	float
	Range: 1E-6 to 100
	Increment: 10E-9
	*RST: 0.001

**Example:** See [Example "Configuring the LF generator"](#) on page 633.

**Manual operation:** See ["Period"](#) on page 115

**[:SOURce<hw>]:LFOutput<ch>:SHAPE:TRlangle:RISE <Rise>**

Selects the rise time for the triangle single of the LF generator.

**Parameters:**

<Rise>	float
	Range: 1E-6 to 100
	Increment: 10E-9
	*RST: 0.5E-3

**Example:** See [Example "Configuring the LF generator"](#) on page 633.

**Manual operation:** See ["Triangle Rise"](#) on page 116

#### 14.16.6.2 LF Sweep Settings

With the commands described in this section, you can configure the sweep of the LF signal.

<code>[:SOURce&lt;hw&gt;]:LFOutput:SWEep[:FREQUENCY]:DWELI</code> .....	642
<code>[:SOURce&lt;hw&gt;]:LFOutput:SWEep[:FREQUENCY]:EXECute</code> .....	642
<code>[:SOURce&lt;hw&gt;]:LFOutput:SWEep[:FREQUENCY]:MODE</code> .....	642
<code>[:SOURce&lt;hw&gt;]:LFOutput:SWEep[:FREQUENCY]:POINts</code> .....	643
<code>[:SOURce&lt;hw&gt;]:LFOutput:SWEep[:FREQUENCY]:RETRace</code> .....	643
<code>[:SOURce&lt;hw&gt;]:LFOutput:SWEep[:FREQUENCY]:RUNNING?</code> .....	643
<code>[:SOURce&lt;hw&gt;]:LFOutput:SWEep[:FREQUENCY]:SHAPE</code> .....	644
<code>[:SOURce&lt;hw&gt;]:LFOutput:SWEep[:FREQUENCY]:SPACing</code> .....	644
<code>[:SOURce&lt;hw&gt;]:LFOutput:SWEep[:FREQUENCY]:STEP:LOGarithmic</code> .....	644
<code>[:SOURce&lt;hw&gt;]:LFOutput:SWEep[:FREQUENCY]:STEP[LINear]</code> .....	645

---

### `[:SOURce<hw>]:LFOutput:SWEep[:FREQUENCY]:DWELI <Dwell>`

Sets the dwell time for each frequency step of the sweep.

#### Parameters:

<code>&lt;Dwell&gt;</code>	float
	Range: 0.001 to 100
	Increment: 100E-6
	*RST: 0.01
	Default unit: s

**Example:** See [Example "Setup an LF sweep"](#) on page 632.

**Manual operation:** See " [Dwell Time](#) " on page 190

---

### `[:SOURce<hw>]:LFOutput:SWEep[:FREQUENCY]:EXECute`

Immediately starts an LF sweep.

`[:SOURce<hw>]:LFOutput:SWEep[:FREQUENCY]:MODE` determines which sweep is executed, e.g. `SOURce:LFOutput:SWEep:FREQUENCY:MODE STEP`.

**Example:** See [Example "Setup an LF sweep"](#) on page 632.

**Usage:** Event

**Manual operation:** See " [Execute Single Sweep](#) " on page 191

---

### `[:SOURce<hw>]:LFOutput:SWEep[:FREQUENCY]:MODE <Mode>`

Sets the cycle mode of the LF sweep.

#### Parameters:

<code>&lt;Mode&gt;</code>	AUTO   MANual   STEP
	<b>AUTO</b>
	Performs a complete sweep cycle from the start to the end value when a trigger event occurs.
	The dwell time determines the time period until the signal switches to the next step.

**MANual**

Performs a single sweep step when a manual trigger event occurs.

The trigger system is not active. To trigger each frequency step of the sweep individually, use the command `[ :SOURce<hw> ] : LFOutput:FREQuency:MANual` on page 636.

**STEP**

Each trigger command triggers one sweep step only.

The frequency increases by the value set with the coammnds:

`[ :SOURce<hw> ] : LFOutput:SWEep [ :FREQuency ] : STEP [ : LINear ]` (linear spacing)

`[ :SOURce<hw> ] : LFOutput:SWEep [ :FREQuency ] : STEP : LOGarithmic` (logarithmic spacing)

\*RST: AUTO

**Example:** See [Example "Setup an LF sweep"](#) on page 632.

**Manual operation:** See ["Mode"](#) on page 187

**[ :SOURce<hw> ] : LFOutput:SWEep [ :FREQuency ] : POINts <Points>**

Sets the number of steps in an LF sweep.

For information on how the value is calculated and the interdependency with other parameters, see [Chapter 7.2.1, "Correlating Parameters in Sweep Mode"](#), on page 179

**Parameters:**

<Points> integer  
 Range: 2 to POINts  
 \*RST: 50

**Example:** See [Example "Setup an LF sweep"](#) on page 632.

**[ :SOURce<hw> ] : LFOutput:SWEep [ :FREQuency ] : RETRace <State>**

Activates that the signal changes to the start frequency value while it is waiting for the next trigger event.

You can enable this feature, when you are working with sawtooth shapes in sweep mode "Single" or "External Single".

**Parameters:**

<State> 0 | 1 | OFF | ON  
 \*RST: 0

**Manual operation:** See ["Retrace"](#) on page 188

**[ :SOURce<hw> ] : LFOutput:SWEep [ :FREQuency ] : RUNNing?**

Queries the current status of the LF frequency sweep mode.

**Return values:**

&lt;State&gt; 0 | 1 | OFF | ON

**Example:** See [Example "Setup an LF sweep"](#) on page 632.**Usage:** Query only**[:SOURce<hw>]:LFOutput:SWEep[:FREQUENCY]:SHAPE <Shape>**

Sets the cycle mode for a sweep sequence (shape).

**Parameters:**<Shape> SAWTooth | TRIangle  
\*RST: SAWTooth**Example:** See [Example "Setup an LF sweep"](#) on page 632.**Manual operation:** See "[Shape](#)" on page 189**[:SOURce<hw>]:LFOutput:SWEep[:FREQUENCY]:SPACing <Spacing>**

Selects linear or logarithmic sweep spacing.

**Parameters:**<Spacing> LINear | LOGarithmic  
\*RST: LINear**Example:** See [Example "Setup an LF sweep"](#) on page 632.**Manual operation:** See "[Spacing](#)" on page 190**[:SOURce<hw>]:LFOutput:SWEep[:FREQUENCY]:STEP:LOGarithmic  
<Logarithmic>**

Sets the step width factor for logarithmic sweeps to calculate the frequencies of the steps.

For information on how the value is calculated and the interdependency with other parameters, see [Chapter 7.2.1, "Correlating Parameters in Sweep Mode"](#), on page 179**Parameters:**<Logarithmic> float  
The unit is mandatory  
Range: 0.01 to 100  
Increment: 0.01  
\*RST: 1  
Default unit: PCT**Example:** See [Example "Setup an LF sweep"](#) on page 632.**Manual operation:** See "[Step Linear/Step Logarithmic](#)" on page 193



**[:SOURce<hw>]:LFOutput:SWEep[:FREQuency]:STEP[:LINear] <Linear>**

Sets the step width for the linear sweep.

For information on how the value is calculated and the interdependency with other parameters, see [Chapter 7.2.1, "Correlating Parameters in Sweep Mode"](#), on page 179

**Parameters:**

<Linear>	float
Range:	0.1 to STOP-START
Increment:	0.1
*RST:	1000

**Example:** See [Example "Setup an LF sweep"](#) on page 632.

**Manual operation:** See "[Step Linear/Step Logarithmic](#)" on page 193

## 14.16.7 SOURce:LIST Subsystem

The SOURce:LIST subsystem contains all commands for defining lists and for handling of list files.

List files have the predefined file extension \*.lsw.

Refer to [Chapter 14.5.2, "Accessing Files in the Default or in a Specified Directory"](#), on page 443 for general information on file handling in the default and in a specific directory.



- \*RST does not affect data lists.
- SCPI refers to the individual lists as segments.

**Example: Create an RF list and activate the list mode**

The following example shows a command sequence to create an RF list and to activate the list mode. Further hardware settings are not considered.

```
// Reset the instrument to start from an initial state
// Query the available list files in the default
// directory /var/user
// Select the list file or create it (if not existing)
*RST; *CLS
SOUR1:LIST:CAT?
// Response:- shows the name of available list files (if applicable)
SOUR1:LIST:SEL "/var/user/list1.lsw"

// Write the frequency/level/dwell time values in the selected list file
// existing data is overwritten
// Query the number of frequency/power/dwell time entries in the selected list
// Query the amount of free memory (in bytes) for list mode lists
SOUR1:LIST:FREQ 58 MHz, 61 MHz, 73 MHz, 86 MHz, 91 MHz, 92 MHz, 98 MHz
SOUR1:LIST:POW 13 dBm, 12 dBm, 5 dBm, 3 dBm, 0 dBm, 4 dBm, 6 dBm
```

```

SOUR1:LIST:DWEL:LIST 10000, 100000, 200000, 19000, 10000, 150000, 220000
SOUR1:LIST:FREQ:POIN?
// 7
SOUR1:LIST:POW:POINT?
// 7
SOUR1:LIST:DWEL:LIST:POIN?
// 7
SOUR1:LIST:FREE?
// 2147483647 (bytes of free memory)

// Use dwell times from list
// Configure the list mode parameters
// Enable RF output
SOUR1:LIST:MODE AUTO
SOUR1:LIST:TRIG:SOUR AUTO
SOUR1:LIST:DWEL:MODE "LIST"

OUTP1:STAT ON

// Use global dwell time
// Set only a part of the list (value pairs 3 to 5) to be processed
// Configure the list mode parameters using global dwell time
// Enable RF output
SOUR1:LIST:IND:START 2
SOUR1:LIST:IND:STOP 4
SOUR1:LIST:MODE AUTO
SOUR1:LIST:TRIG:SOUR AUTO
SOUR1:LIST:DWEL:LIST 500 ms
OUTP1:STAT ON

// Enable the list mode
// Trigger the list (depending on the mode, not needed with trigger
// mode AUTO); query the current index
// Reset the list to the starting point
SOUR1:FREQ:MODE LIST
SOUR1:LIST:TRIG:EXEC
SOUR1:LIST:RUNN?
SOUR1:LIST:IND?
// 3
// value changes when the value is queried again
SOUR1:LIST:RES

// For list mode STEP use the following commands
*RST; *CLS
// Change list mode to STEP
SOUR1:LIST:MODE STEP
// Activate RF Output1
OUTP1:STAT 1
// Activate the list mode
SOUR1:FREQ:MODE LIST
// For each step: select frequency/powerlevel pair as index from the list

```

```

SOUR1:LIST:IND 2
SOUR1:LIST:IND 3
SOUR1:LIST:IND 4

// Use the selected list for path B (with List Mode B default settings)
SOUR2:LIST:SEL "/var/user/list1.lsw"
OUTP2:STAT ON
SOUR2:FREQ:MODE LIST
SOUR2:LIST:IND?
// 2
// value changes when the value is queried again

// Deactivate the list mode
SOUR1:FREQ:MODE CW

```

### Example: List mode data exchange

The following example shows a command sequence to export a list (here the RF list created with the example before) into an ASCII file. Further hardware settings are not considered.

```

*RST; *CLS
LIST:DEXC:MODE EXP

// Set ASCII data parameters
// Set the ASCII file extension, the decimal separator
// and the column separator for the ASCII data
SOUR1:LIST:DEXC:AFIL:EXT CSV
SOUR1:LIST:DEXC:AFIL:SEP:DEC DOT
SOUR1:LIST:DEXC:AFIL:SEP:COL COMM

// Select source and destination path/directory
// Query available listfiles in default directory "/var/user"
SOUR1:LIST:CAT?
// list1
SOUR1:LIST:DEXC:AFIL:SEL "/var/user/list1ASCII"
SOUR1:LIST:DEXC:SEL "/var/user/list1"

// Export the list file data into the ASCII file
SOUR1:LIST:DEXC:EXEC

// Query the available ASCII files with extension .csv
SOUR1:LIST:DEXC:AFIL:CAT?
// Response: "list1ASCII"

// Deactivate the list mode
SOUR1:FREQ:MODE CW

```

- [List Mode Settings](#).....648
- [List Mode File Operation](#).....653
- [List Mode Data Exchange](#).....655

### 14.16.7.1 List Mode Settings

With the following commands, you can create list mode data, select the trigger mode and determine the dwell time.

<code>[:SOURce&lt;hw&gt;]:LIST:DWELI</code> .....	648
<code>[:SOURce&lt;hw&gt;]:LIST:DWELI:MODE</code> .....	648
<code>[:SOURce&lt;hw&gt;]:LIST:DWELI:LIST</code> .....	649
<code>[:SOURce&lt;hw&gt;]:LIST:DWELI:LIST:POINts?</code> .....	649
<code>[:SOURce&lt;hw&gt;]:LIST:FREQUency</code> .....	649
<code>[:SOURce&lt;hw&gt;]:LIST:FREQUency:POINts?</code> .....	650
<code>[:SOURce&lt;hw&gt;]:LIST:INDex</code> .....	650
<code>[:SOURce&lt;hw&gt;]:LIST:INDex:START</code> .....	650
<code>[:SOURce&lt;hw&gt;]:LIST:INDex:STOP</code> .....	650
<code>[:SOURce&lt;hw&gt;]:LIST:MODE</code> .....	651
<code>[:SOURce&lt;hw&gt;]:LIST:POWer</code> .....	651
<code>[:SOURce&lt;hw&gt;]:LIST:POWer:POINts?</code> .....	651
<code>[:SOURce&lt;hw&gt;]:LIST:TRIGger:EXECute</code> .....	652
<code>[:SOURce&lt;hw&gt;]:LIST:TRIGger:SOURce</code> .....	652
<code>[:SOURce&lt;hw&gt;]:LIST:RUNNing?</code> .....	653

---

#### `[:SOURce<hw>]:LIST:DWELI <Dwell>`

Sets the global dwell time. The instrument generates the signal with the frequency / power value pairs of each list entry for that particular period.

See also [Significant Parameters and Functions](#).

#### Parameters:

<code>&lt;Dwell&gt;</code>	float
	Range: 1E-3 to 100
	Increment: 1E-6
	*RST: 0.01

**Example:** See [Example "Create an RF list and activate the list mode"](#) on page 645.

**Manual operation:** See ["Global Dwell Time"](#) on page 201

---

#### `[:SOURce<hw>]:LIST:DWELI:MODE <DwellMode>`

Selects the dwell time mode.

#### Parameters:

<code>&lt;DwellMode&gt;</code>	LIST   GLOBal
	<b>LIST</b>
	Uses the dwell time, specified in the data table for each value pair individually.
	<b>GLOBal</b>
	Uses a constant dwell time, set with command <code>[ : SOURce&lt;hw&gt; ] : LIST : DWELI</code> .

\*RST: GLOBal

**Example:** See [Example "Create an RF list and activate the list mode"](#) on page 645.

**Manual operation:** See ["Dwell Time Mode"](#) on page 201

**[ :SOURce<hw>]:LIST:DWELI:LIST <Dwell>**

Enters the dwell time values in the selected list in  $\mu$ s.

**Parameters:**

<Dwell> <Dwell#1>{, <Dwell#2>, ...} | block data

You can either enter the data as a list of numbers, or as binary block data. The list of numbers can be of any length, with the list entries separated by commas.

In binary block format, 8 (4) bytes are always interpreted as a floating-point number with double accuracy. See also : [FORMat \[ :DATA \]](#) on page 468 for more details.

**Example:** See [Example "Create an RF list and activate the list mode"](#) on page 645.

**Manual operation:** See ["Edit List Mode Data"](#) on page 207

**[ :SOURce<hw>]:LIST:DWELI:LIST:POINTS?**

Queries the number (points) of dwell time entries in the selected list.

**Return values:**

<Points> integer  
 Range: 0 to INT\_MAX  
 \*RST: 0

**Example:** See [Example "Create an RF list and activate the list mode"](#) on page 645.

**Usage:** Query only

**[ :SOURce<hw>]:LIST:FREQuency <Frequency>**

Enters the frequency values in the selected list.

**Parameters:**

<Frequency> <Frequency#1>{, <Frequency#2>, ...} | block data

You can either enter the data as a list of numbers, or as binary block data.

The list of numbers can be of any length, with the list entries separated by commas.

In binary block format, 8 (4) bytes are always interpreted as a floating-point number with double accuracy.

See also : [FORMat \[ :DATA \]](#).

Range: 300 kHz to RFmax (depends on the installed options)

**Example:** See [Example "Create an RF list and activate the list mode"](#) on page 645.

**Manual operation:** See ["Edit List Mode Data"](#) on page 207

### **[ :SOURce<hw> ]:LIST:FREQuency:POINts?**

Queries the number (points) of frequency entries in the selected list.

#### **Return values:**

<Points> integer  
 Range: 0 to INT\_MAX  
 \*RST: 0

**Example:** See [Example "Create an RF list and activate the list mode"](#) on page 645.

**Usage:** Query only

### **[ :SOURce<hw> ]:LIST:INDex <Index>**

Sets the list index in [LIST:MODE STEP](#).

After the trigger signal, the instrument processes the frequency and level settings of the selected index.

#### **Parameters:**

<Index> integer  
 \*RST: 0

**Example:** See [Example "Create an RF list and activate the list mode"](#) on page 645.

**Manual operation:** See [" Current Index "](#) on page 200

### **[ :SOURce<hw> ]:LIST:INDex:STARt <Start>**

### **[ :SOURce<hw> ]:LIST:INDex:STOP <Stop>**

Sets the start and stop index of the index range which defines a subgroup of frequency/level value pairs in the current list.

#### **Parameters:**

<Stop> integer  
 Index range  
 Only values inside this range are processed in list mode  
 Range: 0 to list length  
 \*RST: 0

**Example:** See [Example "Create an RF list and activate the list mode"](#) on page 645.

**Manual operation:** See "List Range from/to" on page 203

---

**[:SOURce<hw>]:LIST:MODE <Mode>**

Sets the list mode.

The instrument processes the list according to the selected mode and trigger source. See [LIST:TRIG:SOUR AUTO](#), [SING](#) or [EXT](#) for the description of the trigger source settings.

**Parameters:**

<Mode>                    AUTO | STEP

**AUTO**

Each trigger event triggers a complete list cycle.

**STEP**

Each trigger event triggers only one step in the list processing cycle. The list is processed in ascending order.

\*RST:                    AUTO

**Example:** See [Example "Create an RF list and activate the list mode"](#) on page 645.

**Manual operation:** See "Mode" on page 201

---

**[:SOURce<hw>]:LIST:POWer <Power>**

Enters the level values in the selected list. The number of level values must correspond to the number of frequency values. Existing data is overwritten.

**Parameters:**

<Power>                    <Power#1>{, <Power#2>, ...} | block data

You can either enter the data as a list of numbers, or as binary block data.

The list of numbers can be of any length, with the list entries separated by commas.

In binary block format, 8 (4) bytes are always interpreted as a floating-point number with double accuracy.

See also [:FORMat \[:DATA\]](#).

Range:                    depends on the installed options

Default unit: dBm

**Example:** See [Example "Create an RF list and activate the list mode"](#) on page 645.

**Manual operation:** See "Edit List Mode Data" on page 207

---

**[:SOURce<hw>]:LIST:POWer:POINts?**

Queries the number (points) of level entries in the selected list.

**Return values:**

<Points> integer  
 Range: 0 to INT\_MAX  
 \*RST: 0

**Example:** See [Example "Create an RF list and activate the list mode"](#) on page 645.

**Usage:** Query only

**[ :SOURce<hw> ] :LIST:TRIGger:EXECute**

Starts the processing of a list in list mode.

**Example:** See [Example "Create an RF list and activate the list mode"](#) on page 645.

**Usage:** Event

**Manual operation:** See "[Execute Single](#)" on page 202

**[ :SOURce<hw> ] :LIST:TRIGger:SOURce <Source>**

Selects the trigger source for processing lists.

The designation of the parameters correspond to those in sweep mode. SCPI standard uses other designations for the parameters, which are also accepted by the instrument. The SCPI designation should be used if compatibility is an important consideration. For an overview, see the following table:

Rohde & Schwarz parameter	SCPI parameter	Applies to the list mode parameters:
AUTO	IMMediate	[ :SOURce<hw> ] :LIST:MODE AUTO
SINGle	BUS	[ :SOURce<hw> ] :LIST:MODE AUTO or [ :SOURce<hw> ] :LIST:MODE STEP
EXTernal	EXTernal	[ :SOURce<hw> ] :LIST:MODE AUTO or [ :SOURce<hw> ] :LIST:MODE STEP

**Parameters:**

<Source> AUTO | IMMediate | SINGle | BUS | EXTernal

**AUTO|IMMediate**

The trigger is free-running, i.e. the trigger condition is fulfilled continuously. The selected list is restarted as soon as it is finished.

**SINGle|BUS**

The list is triggered by the command [ :SOURce<hw> ] :LIST:TRIGger:EXECute. The list is executed once.

**EXTernal**

The list is triggered externally and executed once.

\*RST: AUTO



**Example:** See [Example "Create an RF list and activate the list mode"](#) on page 645.

**Manual operation:** See ["Mode"](#) on page 201

#### **[:SOURce<hw>]:LIST:RUNNING?**

Queries the current state of the list mode.

**Return values:**

<State> 0 | 1 | OFF | ON

**1**

Signal generation based on the list mode is active.

**Example:** See [Example "Create an RF list and activate the list mode"](#) on page 645.

**Usage:** Query only

### 14.16.7.2 List Mode File Operation

The following section covers basic commands to file handling in list mode.

<a href="#">[:SOURce&lt;hw&gt;]:LIST:CATalog?</a> .....	653
<a href="#">[:SOURce&lt;hw&gt;]:LIST:DELeTe</a> .....	653
<a href="#">[:SOURce&lt;hw&gt;]:LIST:DELeTe:ALL</a> .....	654
<a href="#">[:SOURce&lt;hw&gt;]:LIST:FREE?</a> .....	654
<a href="#">[:SOURce&lt;hw&gt;]:LIST:RESet</a> .....	654
<a href="#">[:SOURce&lt;hw&gt;]:LIST:SElect</a> .....	655

#### **[:SOURce<hw>]:LIST:CATalog?**

Queries the available list files in the specified directory.

**Return values:**

<Catalog> string

List of list filenames, separated by commas

**Example:** See [Example "Create an RF list and activate the list mode"](#) on page 645.

**Usage:** Query only

**Manual operation:** See [" List Mode Data "](#) on page 202

#### **[:SOURce<hw>]:LIST:DELeTe <Filename>**

Deletes the specified list.

**Setting parameters:**

<Filename> string

Filename or complete file path; file extension is optional.

**Example:** See [\[:SOURce<hw>\]:LIST:DELeTe:ALL](#) on page 654.

**Usage:** Setting only

**Manual operation:** See " [List Mode Data](#) " on page 202

### **[:SOURce<hw>]:LIST:DELeTe:ALL**

Deletes all lists in the set directory.

This command can only be executed, if:

- No list file is selected.
- List mode is disabled.

**Example:**

```
SOUR1:LIST:CAT?
// list,my_list
SOUR1:LIST:DEL "/var/user/list1"
SOUR1:LIST:CAT?
// my_list
SOUR1:FREQ:MODE?
// LIST
SOUR1:LIST:SEL?
// /var/user/my_list.lsw
//deactivate list mode
SOUR1:FREQ:MODE CW
SOUR1:LIST:DELeTe:ALL
SOUR1:LIST:CAT?
// -
// all list files are deleted
```

**Usage:** Event

**Manual operation:** See " [List Mode Data](#) " on page 202

### **[:SOURce<hw>]:LIST:FREE?**

Queries the amount of free memory (in bytes) for list mode lists.

**Return values:**

```
<Free>          integer
                 Range:    0 to INT_MAX
                 *RST:     0
```

**Example:** See [Example "Create an RF list and activate the list mode"](#) on page 645.

**Usage:** Query only

### **[:SOURce<hw>]:LIST:RESet**

Jumps to the beginning of the list.

**Example:** See [Example "Create an RF list and activate the list mode"](#) on page 645.

**Usage:** Event

**Manual operation:** See "[Reset](#)" on page 202

**[:SOURce<hw>]:LIST:SElect <Filename>**

Selects or creates a data list in list mode.

If the list with the selected name does not exist, a new list is created.

**Parameters:**

<Filename> string  
Filename or complete file path; file extension can be omitted.

**Example:** See [Example "Create an RF list and activate the list mode"](#) on page 645.

**Manual operation:** See "[List Mode Data](#)" on page 202

### 14.16.7.3 List Mode Data Exchange

With the following commands, you can configure lists in ASCII format and export or import them accordingly.

<a href="#">[:SOURce&lt;hw&gt;]:LIST:DEXChange:AFILe:CATalog?</a> .....	655
<a href="#">[:SOURce&lt;hw&gt;]:LIST:DEXChange:EXECute</a> .....	656
<a href="#">[:SOURce&lt;hw&gt;]:LIST:DEXChange:AFILe:EXTension</a> .....	656
<a href="#">[:SOURce&lt;hw&gt;]:LIST:DEXChange:AFILe:SElect</a> .....	656
<a href="#">[:SOURce&lt;hw&gt;]:LIST:DEXChange:AFILe:SEParator:COLumn</a> .....	656
<a href="#">[:SOURce&lt;hw&gt;]:LIST:DEXChange:AFILe:SEParator:DECimal</a> .....	656
<a href="#">[:SOURce&lt;hw&gt;]:LIST:DEXChange:MODE</a> .....	657
<a href="#">[:SOURce&lt;hw&gt;]:LIST:DEXChange:SElect</a> .....	657

**[:SOURce<hw>]:LIST:DEXChange:AFILe:CATalog?**

Queries the available ASCII files for export or import of list mode data in the current or specified directory.

**Return values:**

<Catalog> string  
List of ASCII files \*.txt or \*.csv, separated by commas.

**Example:** See [Example "List mode data exchange"](#) on page 647.

**Usage:** Query only

**Manual operation:** See "[Select \(ASCII\) Source/Select \(ASCII\) Destination](#)" on page 109

---

**[ :SOURce<hw>]:LIST:DEXChange:EXECute**

Executes the import or export of the selected list file, according to the previously set transfer direction with command `[ :SOURce<hw>]:LIST:DEXChange:MODE`

**Example:** See [Example "List mode data exchange"](#) on page 647.

**Usage:** Event

**Manual operation:** See ["Import / Export"](#) on page 109

---

**[ :SOURce<hw>]:LIST:DEXChange:AFILe:EXTension <Extension>**

Determines the extension of the ASCII file for import or export, or to query existing files.

**Parameters:**

<Extension>           TXT | CSV  
\*RST:            TXT

**Example:** See [Example "List mode data exchange"](#) on page 647.

**Manual operation:** See ["ASCII File Settings"](#) on page 108

---

**[ :SOURce<hw>]:LIST:DEXChange:AFILe:SElect <Filename>**

Selects the ASCII file to be imported or exported.

**Parameters:**

<Filename>           string  
Filename or complete file path; file extension can be omitted.

**Example:** See [Example "List mode data exchange"](#) on page 647.

**Manual operation:** See ["Select \(ASCII\) Source/Select \(ASCII\) Destination"](#) on page 109

---

**[ :SOURce<hw>]:LIST:DEXChange:AFILe:SEParator:COLumn <Column>**

Selects the separator between the frequency and level column of the ASCII table.

**Parameters:**

<Column>           TABulator | SEMicolon | COMMa | SPACe  
\*RST:            COMMa

**Example:** See [Example "List mode data exchange"](#) on page 647.

**Manual operation:** See ["ASCII File Settings"](#) on page 108

---

**[ :SOURce<hw>]:LIST:DEXChange:AFILe:SEParator:DECimal <Decimal>**

Sets "." (decimal point) or "," (comma) as the decimal separator used in the ASCII data with floating-point numerals.

**Parameters:**

<Decimal>            DOT | COMMa  
 \*RST:            DOT

**Example:**            See [Example "List mode data exchange"](#) on page 647.

**Manual operation:**    See ["ASCII File Settings"](#) on page 108

**[:SOURce<hw>]:LIST:DEXChange:MODE <Mode>**

Determines the import or export of a list.

Specify the source or destination file with the command [\[:SOURce<hw>\]:LIST:DEXChange:SElect](#).

**Parameters:**

<Mode>            IMPort | EXPort  
 \*RST:            IMPort

**Example:**            See [Example "List mode data exchange"](#) on page 647.

**Manual operation:**    See [" Mode "](#) on page 108

**[:SOURce<hw>]:LIST:DEXChange:SElect <Filename>**

Selects the ASCII file for import or export, containing a list.

**Parameters:**

<Filename>            string  
                           Filename or complete file path; file extension can be omitted.

**Example:**            See [Example "List mode data exchange"](#) on page 647.

**Manual operation:**    See ["Select Source/Select ASCII Destination"](#) on page 109

## 14.16.8 SOURce:NOISe Subsystem

The SOURce:NOISe subsystem contains the commands for:

- Setting the noise modulation signal. The noise generator is optional.

**Example: Configuring the noise generator**

```

SOURcel:NOISe:DIStribution GAUSS
SOURcel:NOISe:BANDwidth 10000000
SOURcel:NOISe:BANDwidth:STATe 1

SOURcel:LFOutput1:SOURce NOIS
SOURcel:LFOutput1:STATe 1

SOURcel:NOISe:LEVel:RELative?
// -83.86
SOURcel:NOISe:LEVel:ABSolute?
// -13.86

```

- [Noise Generator](#).....658

**14.16.8.1 Noise Generator**

<a href="#">[:SOURce&lt;hw&gt;]:NOISe:BANDwidth BWIDTH</a> .....	658
<a href="#">[:SOURce&lt;hw&gt;]:NOISe:BWIDTH:STATe</a> .....	658
<a href="#">[:SOURce&lt;hw&gt;]:NOISe:DIStribution</a> .....	659
<a href="#">[:SOURce&lt;hw&gt;]:NOISe:LEVel:RELative?</a> .....	659
<a href="#">[:SOURce&lt;hw&gt;]:NOISe:LEVel[:ABSolute]?</a> .....	659

**[:SOURce<hw>]:NOISe:BANDwidth|BWIDTH <BWidth>**

Sets the noise level in the system bandwidth when bandwidth limitation is enabled.

**Parameters:**

<BWidth>	float
	Range: 100E3 to 10E6
	Increment: 100E3
	*RST: 100E3

**Example:** See [Example "Configuring the noise generator"](#) on page 658.

**Manual operation:** See ["Bandwidth"](#) on page 118

**[:SOURce<hw>]:NOISe:BWIDTH:STATe <State>**

Activates noise bandwidth limitation.

**Parameters:**

<State>	0   1   OFF   ON
	*RST: 0

**Example:** See [Example "Configuring the noise generator"](#) on page 658.

**Manual operation:** See ["Bandwidth"](#) on page 118

---

**[:SOURce<hw>]:NOISe:DISTRibution <Distribution>**

Sets the distribution of the noise power density.

**Parameters:**

<Distribution>            GAUSs | EQUal  
\*RST:                    GAUSs

**Example:**                See [Example "Configuring the noise generator"](#) on page 658.

**Manual operation:**    See ["Distribution"](#) on page 118

---

**[:SOURce<hw>]:NOISe:LEVel:RELative?**

Queries the level of the noise signal per Hz in the total bandwidth.

**Return values:**

<Relative>                float  
Range:                    -149.18 to -52.67  
Increment:                0.1  
\*RST:                      -69.84

**Example:**                See [Example "Configuring the noise generator"](#) on page 658.

**Usage:**                    Query only

**Manual operation:**    See ["Noise Density"](#) on page 121

---

**[:SOURce<hw>]:NOISe:LEVel[:ABSolute]?**

Queries the level of the noise signal in the system bandwidth within the enabled bandwidth limitation.

**Return values:**

<Absolute>                float  
Noise level within the bandwidth limitation  
\*RST:                      3.84 MHz

**Example:**                See [Example "Configuring the noise generator"](#) on page 658.

**Usage:**                    Query only

**Manual operation:**    See ["Noise Level"](#) on page 121

---

### 14.16.9 SOURce:PGEN Subsystem

The PGEN subsystem contains the commands for setting output of the pulse modulation signal.

**Example: Using pulse generator as source for pulse modulation**

```
// select pulse generator as source for pulse modulation
// enable pulse modulation
SOURce1:PULM:SOURce INT
SOURce1:PULM:STATe 1
// pulse generator and signal output are also activated
SOURce1:PGENerator:STATe?
// 1
SOURce1:PGENerator:OUTPut:STATe?
// 1
PGENerator:OUTPut:POLarity NORMal
// to disable pulse generator
SOURce1:PGENerator:STATe 0
// activate the pulse modulation of the RF carrier
SOURce1:PULM:STATe 1
```

<a href="#">[:SOURce&lt;hw&gt;]:PGENerator:OUTPut:POLarity</a> .....	660
<a href="#">[:SOURce&lt;hw&gt;]:PGENerator:OUTPut[:STATe]</a> .....	660
<a href="#">[:SOURce&lt;hw&gt;]:PGENerator:STATe</a> .....	661

**[:SOURce<hw>]:PGENerator:OUTPut:POLarity <Polarity>**

Sets the polarity of the pulse output signal.

**Parameters:**

<Polarity>                    NORMal | INVerted

**NORMal**

Outputs the pulse signal during the pulse width, that means during the high state.

**INVerted**

Inverts the pulse output signal polarity. The pulse output signal is suppressed during the pulse width, but provided during the low state.

\*RST:                    NORMal

**Example:**                    See [Example "Using pulse generator as source for pulse modulation"](#) on page 660.

**Manual operation:**        See ["Pulse Output Polarity"](#) on page 103

**[:SOURce<hw>]:PGENerator:OUTPut[:STATe] <State>**

Activates the output of the pulse modulation signal.

**Parameters:**

<State>                    0 | 1 | OFF | ON

\*RST:                    0

**Example:**                    See [Example "Using pulse generator as source for pulse modulation"](#) on page 660.



**Manual operation:** See ["Pulse Output State"](#) on page 103

---

**[:SOURce<hw>]:PGENERator:STATe** <State>

Enables the output of the video/sync signal.

If the pulse generator is the current modulation source, activating the pulse modulation automatically activates the signal output and the pulse generator.

**Parameters:**

<State>                    0 | 1 | OFF | ON  
                               \*RST:            0

**Example:**                See [Example "Using pulse generator as source for pulse modulation"](#) on page 660.

### 14.16.10 SOURce:PHASe Subsystem

This subsystem contains the commands for adjusting the phase of the RF output signal relative to a reference signal of the same frequency.

**Example: Programming Example**

```
// change the phase relative to the current phase
SOURce1:PHASe 2 DEG
// adopt the setting as the current phase
SOURce1:PHASe:REFerence
```

The following commands are available:

<a href="#">[:SOURce&lt;hw&gt;]:PHASe</a> .....	661
<a href="#">[:SOURce&lt;hw&gt;]:PHASe:REFerence</a> .....	661

---

**[:SOURce<hw>]:PHASe** <Phase>

Sets the phase variation relative to the current phase.

**Parameters:**

<Phase>                    float  
                               Range:        -36000 to 36000  
                               Increment: 0.001  
                               \*RST:        0  
                               Default unit: DEG

**Example:**                See [Example "Programming Example"](#) on page 661.

**Manual operation:** See ["Delta Phase"](#) on page 79

---

**[:SOURce<hw>]:PHASe:REFerence**

Assigns the value set with command [\[:SOURce<hw>\]:PHASe](#) as the reference phase.

- Example:** See [Example "Programming Example"](#) on page 661.
- Usage:** Event
- Manual operation:** See ["Reset Delta Phase Display"](#) on page 79

### 14.16.11 SOURce:POWer Subsystem

The SOURce:POWer subsystem contains the commands for setting the output level, level control and level correction of the RF signal.

The default units are dBm. To change the units, perform one of the following:

- Enter the unit after the numerical value  
Example: :POW 0.5V
- Set the unit with the command :UNIT:POWer.

<a href="#">[:SOURce&lt;hw&gt;]:POWer:ALC:MODE?</a> .....	662
<a href="#">[:SOURce&lt;hw&gt;]:POWer:ALC[:STATe]</a> .....	663
<a href="#">[:SOURce&lt;hw&gt;]:POWer:ALC:DSensitivity</a> .....	663
<a href="#">[:SOURce&lt;hw&gt;]:POWer:ALC:SONCe</a> .....	664
<a href="#">[:SOURce&lt;hw&gt;]:POWer:ATTenuation:PATTenuator</a> .....	664
<a href="#">[:SOURce&lt;hw&gt;]:POWer:ATTenuation:RFOFF:MODE</a> .....	664
<a href="#">[:SOURce&lt;hw&gt;]:POWer:EMF:STATe</a> .....	664
<a href="#">[:SOURce&lt;hw&gt;]:POWer:LBEHaviour</a> .....	665
<a href="#">[:SOURce&lt;hw&gt;]:POWer:LIMit[:AMPLitude]</a> .....	665
<a href="#">[:SOURce&lt;hw&gt;]:POWer:MANual</a> .....	665
<a href="#">[:SOURce&lt;hw&gt;]:POWer:MODE</a> .....	666
<a href="#">[:SOURce&lt;hw&gt;]:POWer:POWer</a> .....	666
<a href="#">[:SOURce&lt;hw&gt;]:POWer:START</a> .....	667
<a href="#">[:SOURce&lt;hw&gt;]:POWer:STOP</a> .....	667
<a href="#">[:SOURce&lt;hw&gt;]:POWer:STEP:MODE</a> .....	667
<a href="#">[:SOURce&lt;hw&gt;]:POWer:STEP[:INCRement]</a> .....	668
<a href="#">[:SOURce&lt;hw&gt;]:POWer[:LEVel][:IMMediate]:OFFSet</a> .....	668
<a href="#">[:SOURce&lt;hw&gt;]:POWer[:LEVel][:IMMediate]:RCL</a> .....	669
<a href="#">[:SOURce&lt;hw&gt;]:POWer[:LEVel][:IMMediate][:AMPLitude]</a> .....	669
<a href="#">[:SOURce&lt;hw&gt;]:POWer:RANGe:LOWer?</a> .....	670
<a href="#">[:SOURce&lt;hw&gt;]:POWer:RANGe:UPPer?</a> .....	670
<a href="#">[:SOURce&lt;hw&gt;]:POWer:RANGe:MIN?</a> .....	670
<a href="#">[:SOURce&lt;hw&gt;]:POWer:RANGe:MAX?</a> .....	670
<a href="#">[:SOURce]:POWer:WIGNore</a> .....	670

---

#### **[\[:SOURce<hw>\]:POWer:ALC:MODE?](#)**

Queries the currently set ALC mode.

See [\[:SOURce<hw>\]:POWer:ALC\[:STATe\]](#) on page 663.

#### **Return values:**

<PowAlcMode> 0 | AUTO | 1 | PRESet | OFFTable | ON | OFF | ONSample | ONTable

**Example:** POW:ALC:MODE?  
Response: ONTable "Table and On" is set automatically.

**Usage:** Query only

**[:SOURce<hw>]:POWER:ALC[:STATe] <State>**

**Parameters:**

<State> 0 | OFF | AUTO | 1 | ON | ONTable | PRESet | OFFTable

**AUTO**

Adjusts the output level to the operating conditions automatically.

**1|ON**

Activates internal level control permanently.

**OFFTable**

Controls the level using attenuation values of the internal ALC table.

**0|OFF**

Provided only for backward compatibility with other Rohde & Schwarz signal generators.

The R&S SMA100B accepts these values and maps them automatically as follows:

0|OFF = OFFTable

**ONTable**

Starts with the attenuation setting from the table and continues with automatic level control.

\*RST: AUTO

**Example:** POW:ALC ON  
Activates internal level control.

**Manual operation:** See "[State](#)" on page 216

**[:SOURce<hw>]:POWER:ALC:DSENSitivity <Sensitivity>**

Sets the sensitivity of the ALC detector.

**Parameters:**

<Sensitivity> AUTO | FIXed

**AUTO**

Selects the optimum sensitivity automatically.

**FIXed**

Fixes the internal level detector.

\*RST: AUTO

**Example:** POW:ALC:DSEN FIX

**Manual operation:** See "[Detector Sensitivity](#)" on page 216

---

**[[:SOURce<hw>]:POWer:ALC:SONC**

Activates level control for correction purposes temporarily.

**Example:**            POW:ALC OFF  
Deactivates automatic level control at the RF output.  
                     POW:ALC:SONC  
Executes level control (once).

**Usage:**             Event

**Manual operation:** See "[Readjust](#)" on page 78

---

**[[:SOURce<hw>]:POWer:ATTenuation:PATTenuator <StepAttSel>**

Selects the type of step attenuator used below 20 GHz.

**Parameters:**  
<StepAttSel>        MECHanical | ELECTronic  
**MECHanical**  
Uses the mechanical step attenuator at all frequencies.  
**ELECTronic**  
Uses the electronic step attenuator up to 20 GHz.

**Options:**            R&S SMAB-B35/-B37/-B39

**Manual operation:** See "[Step Attenuator below 20 GHz](#)" on page 213

---

**[[:SOURce<hw>]:POWer:ATTenuation:RFOff:MODE <Mode>**

Selects the state the attenuator is to assume if the RF signal is switched off.

**Parameters:**  
<Mode>              UNCHanged | FATTenuation  
**FATTenuation**  
The step attenuator switches to maximum attenuation  
**UNCHanged**  
Retains the current setting and keeps the output impedance constant during RF off.  
\*RST:                n.a. (factory preset: FATTenuation)

**Example:**            SOURce1:POWer:ATTenuation:RFOff:MODE  
                     FATTenuation  
                     uses maximum attenuation when the RF output is turned off.

**Manual operation:** See "[RF OFF Mode](#)" on page 213

---

**[[:SOURce<hw>]:POWer:EMF:STATe <State>**

Displays the signal level as voltage of the EMF. The displayed value represents the voltage over a 50 Ohm load.

**Parameters:**

<State> 0 | 1 | OFF | ON  
 \*RST: n.a. (factory preset: 0)

**Example:**

POW:EMF:STAT 1  
 Activates voltage level display.

**Manual operation:** See " [Display Level as Voltage of EMF](#) " on page 340

**[:SOURce<hw>]:POWer:LBEHaviour <Behaviour>****Parameters:**

<Behaviour> AUTO | UNINterrupted | MONotone | CVSWr | HDUN  
**UNINterrupted|MONotone**  
 Uninterrupted level settings and strictly monotone modes.  
**CVSWr**  
 Constant VSWR  
**HDUN**  
 High dynamic uninterrupted level settings.  
 \*RST: AUTO

**Example:**

SOURce1:POWer:LBEHaviour AUTO

**Options:**

R&S SMAB-K724

**Manual operation:** See " [Setting Characteristics](#) " on page 76

**[:SOURce<hw>]:POWer:LIMit[:AMPLitude] <Amplitude>**

Limits the maximum RF output level in CW and sweep mode.

It does not influence the "Level" display or the response to the query `[ :SOURce<hw> ] :POWer[:LEVel] [:IMMediate] [:AMPLitude]`.

**Parameters:**

<Amplitude> float  
 Range: depends on the installed options  
 Increment: 0.01  
 \*RST: n.a. (factory preset: 30)

**Example:**

SOURce1:POWer:LIMit:AMPLitude 10

**Manual operation:** See " [Limit](#) " on page 76

**[:SOURce<hw>]:POWer:MANual <Manual>**

Sets the level for the subsequent sweep step if `SWE:POW:MODE MAN`.

Use a separate command for each sweep step.

**Parameters:**

<Manual> float

You can select any level within the setting range, where:

START is set with `[ :SOURce<hw> ] :POWER:START`

STOP is set with `[ :SOURce<hw> ] :POWER:STOP`

OFFSet is set with `[ :SOURce<hw> ] :POWER [ :LEVel ] [ :IMMediate ] :OFFSet`

Range: (START + OFFSet) to (STOP + OFFSet)

Increment: 0.01

Default unit: dBm

**Example:** See [Example "Setup an RF frequency or power sweep"](#) on page 676

**Manual operation:** See "[Current Level](#)" on page 187

### `[ :SOURce<hw> ] :POWER:MODE <Mode>`

Selects the operating mode of the instrument to set the output level.

#### Parameters:

<Mode> CW | FIXed | SWEep

#### **CW|FIXed**

Operates at a constant level.

CW and FIXed are synonyms.

To set the output level value, use the command `[ :SOURce<hw> ] :POWER [ :LEVel ] [ :IMMediate ] [ :AMPLitude ]`.

#### **SWEep**

Sets sweep mode.

Set the range and current level with the commands:

`[ :SOURce<hw> ] :POWER:START` and `[ :SOURce<hw> ] :POWER:STOP`,

`[ :SOURce<hw> ] :POWER:MANual`.

\*RST: CW

**Example:** See [Example "Setup an RF frequency or power sweep"](#) on page 676

**Manual operation:** See "[State \(RF level sweep\)](#)" on page 187

### `[ :SOURce<hw> ] :POWER:POWER <Power>`

Sets the level **at the RF output** connector.

This value does not consider a specified offset.

The command `[ :SOURce<hw> ] :POWER [ :LEVel ] [ :IMMediate ] [ :AMPLitude ]` sets the level of the "Level" display, that means the level containing offset.

See "[RF frequency and level display with a downstream instrument](#)" on page 68.

**Parameters:**

<Power> float  
 Level at the RF output, without level offset  
 Range: See data sheet  
 Increment: 0.01  
 Default unit: dBm

**Example:**

SOURce1:POWer:POWer 15  
 Sets the level at RF output

**Manual operation:** See ["Amplitude"](#) on page 75

**[ :SOURce<hw>]:POWer:START <Start>**

**[ :SOURce<hw>]:POWer:STOP <Stop>**

Sets the RF start/stop level in sweep mode.

**Parameters:**

<Stop> float  
 Sets the setting range calculated as follows:  
 (Level\_min + OFFSet) to (Level\_max + OFFSet)  
 Where the values are set with the commands:  
[\[ :SOURce<hw>\]:POWer\[:LEVel\]\[:IMMediate\]:OFFSet](#)  
[\[ :SOURce<hw>\]:POWer:START](#)  
[\[ :SOURce<hw>\]:POWer:STOP](#)  
 Range: Minimum level to maximum level  
 \*RST: -30 (Start)/ -10 (Stop)  
 Default unit: dBm

**Example:**

See [Example "Setup an RF frequency or power sweep"](#) on page 676

**Manual operation:** See [" Start Level / Stop Level "](#) on page 194

**[ :SOURce<hw>]:POWer:STEP:MODE <Mode>**

Defines the type of step width to vary the RF output power step-by-step with the commands [POW UP](#) or [POW DOWN](#).

**Parameters:**

<Mode> DECimal | USER  
**DECimal**  
 Increases or decreases the level in steps of ten.  
**USER**  
 Increases or decreases the level in increments, determined with the command [\[ :SOURce<hw>\]:POWer:STEP\[:INCRement\]](#).  
 \*RST: DECimal

**Example:**           SOURce1:POWer:STEP:INCRement 2  
                   SOURce1:POWer:STEP:MODE USER  
                   SOURce1:POWer:LEVel:IMMediate:AMPLitude UP  
                   Increasing the RF level with a step size of 2 dB

**Manual operation:** See "[Variation Active](#)" on page 73

#### **[[:SOURce<hw>]:POWer:STEP[:INCRement] <Increment>**

Specifies the step width in the appropriate path for `POW:STEP:MODE USER`.

To adjust the level step-by-step with this increment value, use the command `POW UP`, or `POW DOWN`.

**Note:** The command also sets "Variation Step" in the manual control, that means the user-defined step width for setting the level with the rotary knob or the [Up/Down] arrow keys.

#### **Parameters:**

<Increment>           float  
                           Range:       0 to 200  
                           Increment: 0.01  
                           \*RST:       1  
                           Default unit: dB

**Example:**           See `[[:SOURce<hw>]:POWer:STEP:MODE` on page 667.

**Manual operation:** See "[Variation Step](#)" on page 73

#### **[[:SOURce<hw>]:POWer[:LEVel]][:IMMediate]:OFFSet <Offset>**

Sets the level offset of a downstream instrument.

The level at the RF output is not changed.

To query the resulting level, as it is at the output of the downstream instrument, use the command `[[:SOURce<hw>]:POWer[:LEVel]][:IMMediate]][:AMPLitude]`.

See "[RF frequency and level display with a downstream instrument](#)" on page 68.

**Note:** The level offset also affects the RF level sweep.

#### **Parameters:**

<Offset>               float  
                           Range:       -100 to 100  
                           Increment: 0.01  
                           \*RST:       0  
                           Default unit: dB  
                           Level offset is always expreced in dB; linear units (V, W, etc.) are not supported

**Example:**           `POWer:OFFSet 10`  
                   Sets the RF level offset to 10 dB

**Manual operation:** See "[Offset](#)" on page 76



---

**[ :SOURce<hw>]:POWER[:LEVel][:IMMediate]:RCL <Rcl>**

Determines whether the current level is retained or if the stored level setting is adopted when an instrument configuration is loaded.

**Parameters:**

<Rcl> INCLude | EXCLude

**INCLude**

Takes the current level when an instrument configuration is loaded.

**EXCLude**

Retains the current level when an instrument configuration is loaded.

\*RST: INCLude

**Example:**

POW:RCL INCL

Takes the level value from an instrument configuration loaded with command \*RCL.

**Manual operation:** See "Exclude Level" on page 314

---

**[ :SOURce<hw>]:POWER[:LEVel][:IMMediate][:AMPLitude] <Amplitude>**

Sets the RF level applied to the DUT.

To activate the RF output use command :OUTPut<hw>[:STATe] ("RF On"/"RF Off").

The following applies  $POWER = RF \text{ output level} + OFFSET$ , where:

- POWER is the values set with [:SOURce<hw>]:POWER[:LEVel][:IMMediate][:AMPLitude]
- RF output level is set with [:SOURce<hw>]:POWER:POWER
- OFFSET is set with [:SOURce<hw>]:POWER[:LEVel][:IMMediate]:OFFSET

**Parameters:**

<Amplitude> float

The following settings influence the value range:

OFFSET set with the command [:SOURce<hw>]:POWER[:LEVel][:IMMediate]:OFFSET

**Numerical value**

Sets the level

**UP|DOWN**

Varies the level step by step.

The level is increased or decreased by the value set with the command [:SOURce<hw>]:POWER:STEP[:INCRement].

Range: (Level\_min + OFFSET) to (Level\_max + OFFSET)

\*RST: -30

Default unit: dBm

**Example:**

POWER -30

Sets the RF level

**Example:** See also `[ :SOURce<hw> ] :POWER:STEP:MODE` on page 667.

**Manual operation:** See "[Amplitude](#)" on page 75

**[ :SOURce<hw> ] :POWER:RANGe:LOWer?**

**[ :SOURce<hw> ] :POWER:RANGe:UPPer?**

Queries the current interruption-free range of the level.

**Return values:**

<Upper> float  
 Increment: 0.01  
 Default unit: dBm

**Example:**

```
SOURce1:POWER:RANGe:UPPer?
// -15
SOURce1:POWER:RANGe:LOW?
// -50
```

**Usage:** Query only

**Manual operation:** See "[Level Range](#)" on page 77

**[ :SOURce<hw> ] :POWER:RANGe:MIN?**

**[ :SOURce<hw> ] :POWER:RANGe:MAX?**

Queries the current power range of the level sweep.

**Return values:**

<PowRangeMax> float  
 Range: depends on settings  
 Increment: 0.01  
 \*RST: -10  
 Default unit: dBm

**Example:**

```
SOURce1:POWER:RANGe:MIN?
// -90
SOURce1:POWER:RANGe:MAX?
// 8
```

**Usage:** Query only

**Manual operation:** See "[Sweep Level Range](#)" on page 196

**[ :SOURce ] :POWER:WIGNore <State>**

Ignores level range warnings.

**Parameters:**

<State> 0 | 1 | OFF | ON  
 \*RST: n.a. (factory preset: 0)

**Example:**

```
SOURce:POWER:WIGNore 1
```

### 14.16.12 SOURce:ROSCillator Subsystem

The SOURce:ROSCillator subsystem contains the commands for setting the external and internal reference frequency.



The commands of this subsystem are not affected by an instrument reset (\*RST on page 438).

#### Example: Configuring the reference oscillator

```
// Using 100 MHz external reference source
SOURce:ROSCillator:PRESet
SOURce:ROSCillator:SOURce EXT
SOURce:ROSCillator:EXTernal:RFOFf:STATe 1
SOURce:ROSCillator:EXTernal:FREQuency 100MHZ
SOURce:ROSCillator:EXTernal:SBANdwidth WIDE
// 100 MHz (loop through) and 1 GHz output
SOURce:ROSCillator:OUTPut:FREQuency:MODE LOOP
SOURce:ROSCillator:OUTPut:ALternate:FREQuency:MODE DER1G
SOURce:ROSCillator:INTernal:ADJust:STATe 0

// Variable external reference frequency
// SOURce:ROSCillator:EXTernal:FREQuency VAR
// SOURce:ROSCillator:EXTernal:FREQuency:VARIable 100000000

// Using the internal reference frequency
SOURce:ROSCillator:SOURce INT
SOURce:ROSCillator:INTernal:TUNing:STATe 1
SOURce:ROSCillator:INTernal:TUNing:SLOPe LOW
// 10 MHz and 1 GHz output
SOURce:ROSCillator:OUTPut:FREQuency:MODE DER10M
SOURce:ROSCillator:OUTPut:ALternate:FREQuency:MODE DER1G

// Query calibration value
CALibration:ROSCillator?
// 32767
// Set an internal source
// Activate user-defined adjustment value of 1000
SOURce:ROSCillator:SOURce INT
SOURce:ROSCillator:INTernal:ADJust:STATe 1
SOURce:ROSCillator:INTernal:ADJust:VALue 1000

// to resume calibrated state
SOURce:ROSCillator:INTernal:ADJust:VALue 0
SOURce:ROSCillator:INTernal:ADJust:STATe 0
// or
// SYSTem:FPRest
```

<a href="#">[:SOURce]:ROSCillator:PRESet</a> .....	672
<a href="#">[:SOURce]:ROSCillator:SOURce</a> .....	672
<a href="#">[:SOURce]:ROSCillator:INTernal:TUNing[:STATe]</a> .....	672

<code>[:SOURce]:ROSCillator:INTernal:TUNing:SLOPe</code> .....	672
<code>[:SOURce]:ROSCillator:EXTernal:RFOff[:STATe]</code> .....	673
<code>[:SOURce]:ROSCillator:EXTernal:FREQuency</code> .....	673
<code>[:SOURce]:ROSCillator:EXTernal:FREQuency:VARiable</code> .....	673
<code>[:SOURce]:ROSCillator:EXTernal:SBANdwidth</code> .....	673
<code>[:SOURce]:ROSCillator:EXTernal:MLRange?</code> .....	674
<code>[:SOURce]:ROSCillator:EXTernal:NSBandwidth?</code> .....	674
<code>[:SOURce]:ROSCillator:OUTPut:FREQuency:MODE</code> .....	674
<code>[:SOURce]:ROSCillator:OUTPut:ALternate:FREQuency:MODE</code> .....	675
<code>[:SOURce]:ROSCillator[:INTernal]:ADJust:VALue</code> .....	675
<code>[:SOURce]:ROSCillator[:INTernal]:ADJust[:STATe]</code> .....	676

---

### `[:SOURce]:ROSCillator:PRESet`

Resets the reference oscillator settings.

**Example:** See [Example "Configuring the reference oscillator"](#) on page 671.

**Usage:** Event

**Manual operation:** See ["Set to Default"](#) on page 290

---

### `[:SOURce]:ROSCillator:SOURce <Source>`

Selects between internal or external reference frequency.

**Parameters:**

`<Source>` INTernal | EXTernal  
 \*RST: n.a. (factory preset: INTernal)

**Example:** See [Example "Configuring the reference oscillator"](#) on page 671.

**Manual operation:** See ["Source"](#) on page 290

---

### `[:SOURce]:ROSCillator:INTernal:TUNing[:STATe] <State>`

Activates the EFC (external frequency control).

**Parameters:**

`<State>` 0 | 1 | OFF | ON  
 \*RST: n.a. (factory preset: 1)

**Example:** See [Example "Configuring the reference oscillator"](#) on page 671.

**Manual operation:** See ["External Tuning Active"](#) on page 292

---

### `[:SOURce]:ROSCillator:INTernal:TUNing:SLOPe <State>`

Sets the sensitivity of the external tuning volatge.

**Parameters:**

`<State>` LOW | HIGH  
 \*RST: n.a. (factory preset: LOW)

**Example:** See [Example "Configuring the reference oscillator"](#) on page 671.

**Manual operation:** See ["External Tuning Slope"](#) on page 292

**[[:SOURce]:ROSCillator:EXTernal:RFOFF[:STATe] <State>**

Determines that the RF output is turned off when the external reference signal is selected, but missing.

**Parameters:**

<State> 0 | 1 | OFF | ON  
 \*RST: n.a. (factory preset: 0)

**Example:** See [Example "Configuring the reference oscillator"](#) on page 671.

**Manual operation:** See ["Deactivate RF Output \(if external reference is missing\)"](#) on page 290

**[[:SOURce]:ROSCillator:EXTernal:FREQUency <Frequency>**

Sets the frequency of the external reference.

**Parameters:**

<Frequency> 100MHZ | 1GHZ | VARiable | 10MHZ  
 \*RST: n.a. (factory preset: 10MHZ)

**Example:** See [Example "Configuring the reference oscillator"](#) on page 671.

**Options:** VARiable requires R&S SMAB-K704  
 100MHZ|1GHZ require R&S SMAB-K703

**Manual operation:** See ["External Reference Frequency"](#) on page 290

**[[:SOURce]:ROSCillator:EXTernal:FREQUency:VARiable <Frequency>**

Specifies the user-defined external reference frequency.

**Parameters:**

<Frequency> float  
 Range: 1E6 to 100E6  
 Increment: 0.1  
 \*RST: n.a. (factory preset: 1E7)  
 Default unit: Hz

**Example:** See [Example "Configuring the reference oscillator"](#) on page 671.

**Options:** R&S SMAB-K704

**Manual operation:** See ["Variable Reference Frequency"](#) on page 291

**[[:SOURce]:ROSCillator:EXTernal:SBANDwidth <SBandwidth>**

Selects the synchronization bandwidth for the external reference signal.

Depending on the RF hardware version, and the installed options, the synchronisation bandwidth varies.

For more information, see data sheet.

**Parameters:**

<SBandwidth> WIDE | NARRow

**NARRow**

The synchronization bandwidth is a few Hz.

**WIDE**

Uses the widest possible synchronization bandwidth.

\*RST: n.a. (factory preset)

**Example:** See [Example "Configuring the reference oscillator"](#) on page 671.

**Manual operation:** See ["Synchronization Bandwidth"](#) on page 291

**[[:SOURce]:ROSCillator:EXTernal:MLRange?**

Queries the minimum locking range for the selected external reference frequency.

Depending on the RF hardware version, and the installed options, the minimum locking range vaies.

For more information, see data sheet.

**Return values:**

<MinLockRange> string

**Example:** SOUR:ROSC:EXT:MLR?

**Usage:** Query only

**Manual operation:** See ["Minimum Locking Range"](#) on page 291

**[[:SOURce]:ROSCillator:EXTernal:NSBandwidth?**

Queries the nominal synchronization bandwidth for the selected external reference frequency and synchronization bandwidth.

**Return values:**

<NomBandwidth> string

**Example:** SOUR:ROSC:EXT:NSB?

**Usage:** Query only

**Manual operation:** See ["Nominal Synchronization Bandwidth"](#) on page 291

**[[:SOURce]:ROSCillator:OUTPut:FREQuency:MODE <OutpFreqMode>**

Sets the output reference frequency.

**Parameters:**

<OutpFreqMode> DER10M | DER100M | OFF | LOOPthrough

**OFF**

Disables the output.

**DER10M|DER100M**

Sets the output reference frequency to 10 MHz or 100 MHz. The reference frequency is derived from the internal reference frequency.

**LOOPthrough**

This option is unavailable for `ROSCillator:EXTernal:FREQuency 1GHZ`. Forwards the input reference frequency to the reference frequency output.

\*RST: n.a. (factory preset: DER10M)

**Example:** See [Example "Configuring the reference oscillator"](#) on page 671.

**Manual operation:** See ["Reference Output/1 GHz Reference Output"](#) on page 292

**[:SOURce]:ROSCillator:OUTPut:ALTErnate:FREQuency:MODE <OutpFreqMode>**

Sets the output reference frequency.

**Parameters:**

<OutpFreqMode> LOOPthrough | DER1G | OFF

**OFF**

Disables the output.

**DER1G**

Sets the output reference frequency to 1 GHz. The reference frequency is derived from the internal reference frequency.

**LOOPthrough**

If `[ :SOURce ] :ROSCillator:EXTernal:FREQuency1GHZ`, forwards the input reference frequency to the reference frequency output.

\*RST: n.a. (factory preset: OFF)

**Example:** See [Example "Configuring the reference oscillator"](#) on page 671.

**Manual operation:** See ["Reference Output/1 GHz Reference Output"](#) on page 292

**[:SOURce]:ROSCillator[:INTernal]:ADJust:VALue <Value>**

Specifies the frequency correction value (adjustment value).

**Parameters:**

<Value> integer

\*RST: 0

**Example:** See `[ :SOURce ] :ROSCillator [ :INTernal ] :ADJust [ :STATe ]` on page 676

**Manual operation:** See ["Adjustment Value"](#) on page 294

**[ :SOURce]:ROSCillator[:INTernal]:ADJust[:STATe] <State>**

Determines whether the calibrated (off) or a user-defined (on) **adjustment value** is used for fine adjustment of the frequency.

**Parameters:**

<State> 0 | 1 | OFF | ON

**0**

Fine adjustment with the calibrated frequency value

**1**

User-defined adjustment value.

The instrument is no longer in the calibrated state.

The calibration value is, however, not changed. The instrument resumes the calibrated state if you send

`SOURce:ROSCillator:INTernal:ADJust:STATe 0.`

\*RST: n.a. (factory preset: 0)

**Example:** See [Example "Configuring the reference oscillator"](#) on page 671.

**Manual operation:** See ["Adjustment Active"](#) on page 293

### 14.16.13 SOURce:SWEep Subsystem

The `SOURce:SWEep` subsystem contains the commands for configuring RF sweep signals.



- The keyword `[ :FREQuency]` can be omitted, then the commands are SCPI-compliant.
- To activate an RF sweep mode, use the following commands:
  - RF frequency sweep: `SOURce:FREQuency:MODE SWEep`  
(`SOURce:FREQuency:MODE CW (off)`)
  - RF level sweep: `SOURce:POWEr:MODE SWEep` (`SOURce:POWEr:MODE CW (off)`)
  - RF combined sweep: `SOURce:FREQuency:MODE SWEep`  
(`SOURce:FREQuency:MODE CW (off)`)
- All sweeps, including the LF sweep, can be set independently of each other.
- All sweeps can be set independently of each other.

See [Chapter 7.1, "Signal Generation and Triggering in the Sweep and List Modes"](#), on page 171.

**Example: Setup an RF frequency or power sweep**

The following example shows a command sequence to set up an RF frequency sweep, triggered by the execute command. For an RF power sweep, replace `FREQuency` in the `SWEep` commands with `POWEr`.

Exceptions are the power spacing (defined with `LINear` only) and the power step width (defined with `LOGarithmic` only).



```

// Reset the instrument to start from an initial state
// Switch off display update to improve performance
// (especially with short dwell times)
// Set the sweep mode (first two commands) and the sweep range
// Select linear spacing
// Select the waveform shape for the frequency sweep
*RST; *CLS
SYSTem:DISPlay:UPDate OFF
TRIGger1:FSWEEP:SOURce SINGLE
SOURcel:SWEep:FREQuency:MODE AUTO
SOURcel:FREQuency:SPAN 300 MHz
SOURcel:FREQuency:CENTer 200 MHz
// Alternatively use
// SOURcel:FREQuency:STARt 50 MHz
// SOURcel:FREQuency:STOP 350 MHz
SOURcel:SWEep:FREQuency:SPACing LINear
SOURcel:SWEep:FREQuency:SHAPE SAWTooth

// Activate change to start frequency while waiting for next trigger
// Prerequisites: sweep mode single and sweep waveform sawtooth
SOURcel:SWEep:FREQuency:RETRace 1
// Alternatively reset all sweeps to their initial value
SOURcel:SWEep:RESet:ALL

// Set the step width and dwell time
SOURcel:SWEep:FREQuency:STEP:LINear 1 MHz
// Alternatively set the number of steps, then the sweep step width is
// set automatically
SOURcel:SWEep:FREQuency:POINts 301
SOURcel:SWEep:FREQuency:DWELL 500 ms
// With logarithmic spacing select the step width as follows
// (steps of 10 percent of the previous frequency in each instance)
SOURcel:SWEep:FREQuency:SPACing LOG
SOURcel:SWEep:FREQuency:STEP:LOGarithmic 10PCT

// Activate the sweep
// Trigger the sweep (depending on the set mode) and query the status
SOURcel:FREQuency:MODE SWEep
// Perform a one-off RF frequency sweep
SOURcel:SWEep:FREQuency:EXECute
SOURcel:SWEep:FREQuency:RUNning?
// 1
// the frequency sweep is running

// For manual step RF sweep use the following commands
*RST; *CLS
// Activate manual step RF sweep
SOURcel:SWEep:FREQuency:MODE MANual
// Activate the RF frequency sweep.
SOURcel:FREQuency:MODE SWEep

```

```

// Activate RF Output1.
Output1:STATE 1
// Input the frequency manually for each step
SOURCE:FREQUENCY:MANual 200 MHz
SOURCE:FREQUENCY:MANual 201 MHz
// Alternatively use the UP or DOWN commands with the set step width.
SOURCE:SWEep:FREQUENCY:STEP:LINear 1 MHz
SOURCE:FREQUENCY:MANual UP

// Activate combined RF frequency / level sweep
*RST; *CLS
*RST; *CLS
SYSTEM:DISPlay:UPDate OFF
TRIGger1:FSWep:SOURce SINGLE
SOURCE:SWEep:COMBined:MODE AUTO
SOURCE:SWEep:COMBined:COUNT 200
SOURCE:FREQUENCY:START 1000000000 Hz
SOURCE:FREQUENCY:STOP 5000000000 Hz
SOURCE:POWER:START -30 dBm
SOURCE:POWER:STOP -10 dBm
SOURCE:SWEep:COMBined:RETRace 1
SOURCE:SWEep:COMBined:SHAPE SAWT
SOURCE:SWEep:COMBined:DWELL 0.01
// Activate combined RF frequency/level sweep
SOURCE:FREQUENCY:MODE COMB
// Activate RF Output1.
Output1:STATE 1
// Execute combined frequency / level sweep
SOURCE:SWEep:COMBined:EXECute

```

:SWEep:TYPE.....	679
[:SOURCE<hw>]:SWEep:POWER:DWELL.....	679
[:SOURCE<hw>]:SWEep:GENERation.....	679
[:SOURCE<hw>]:SWEep:POWER:MODE.....	680
[:SOURCE<hw>]:SWEep:POWER:POINTS.....	680
[:SOURCE<hw>]:SWEep:POWER:SPACing:MODE?.....	680
[:SOURCE<hw>]:SWEep:POWER:STEP[:LOGarithmic].....	681
[:SOURCE<hw>]:SWEep[:FREQUENCY]:DWELL.....	681
[:SOURCE<hw>]:SWEep[:FREQUENCY]:MODE.....	681
[:SOURCE<hw>]:SWEep[:FREQUENCY]:POINTS.....	682
[:SOURCE<hw>]:SWEep[:FREQUENCY]:SPACing.....	682
[:SOURCE<hw>]:SWEep:POWER:SHAPE.....	683
[:SOURCE<hw>]:SWEep[:FREQUENCY]:SHAPE.....	683
[:SOURCE<hw>]:SWEep:POWER:EXECute.....	683
[:SOURCE<hw>]:SWEep[:FREQUENCY]:EXECute.....	683
[:SOURCE<hw>]:SWEep:POWER:RETRace.....	683
[:SOURCE<hw>]:SWEep[:FREQUENCY]:RETRace.....	683
[:SOURCE<hw>]:SWEep:POWER:RUNNING?.....	684
[:SOURCE<hw>]:SWEep[:FREQUENCY]:RUNNING?.....	684
[:SOURCE<hw>]:SWEep[:FREQUENCY]:STEP:LOGarithmic.....	684
[:SOURCE<hw>]:SWEep[:FREQUENCY]:STEP[:LINear].....	684

<code>[:SOURce&lt;hw&gt;]:COMBined:FREQuency:STARt</code> .....	685
<code>[:SOURce&lt;hw&gt;]:COMBined:FREQuency:STOP</code> .....	685
<code>[:SOURce&lt;hw&gt;]:COMBined:POWer:STARt</code> .....	685
<code>[:SOURce&lt;hw&gt;]:COMBined:POWer:STOP</code> .....	686
<code>[:SOURce&lt;hw&gt;]:SWEep:COMBined:COUNT</code> .....	686
<code>[:SOURce&lt;hw&gt;]:SWEep:COMBined:DWELI</code> .....	686
<code>[:SOURce&lt;hw&gt;]:SWEep:COMBined:EXECute</code> .....	686
<code>[:SOURce&lt;hw&gt;]:SWEep:COMBined:MODE</code> .....	687
<code>[:SOURce&lt;hw&gt;]:SWEep:COMBined:RETRace</code> .....	687
<code>[:SOURce&lt;hw&gt;]:SWEep:COMBined:SHAPE</code> .....	688
<code>[:SOURce&lt;hw&gt;]:SWEep:RESet[:ALL]</code> .....	688
<code>[:SOURce&lt;hw&gt;]:SWEep[:FREQuency]:TIME</code> .....	688
<code>[:SOURce&lt;hw&gt;]:SWEep:MARKer:OUTPut:POLarity</code> .....	688
<code>[:SOURce&lt;hw&gt;]:SWEep[:FREQuency]:MARKer:ACTive</code> .....	689
<code>[:SOURce&lt;hw&gt;]:SWEep[:FREQuency]:MARKer&lt;ch&gt;:FREQuency</code> .....	689
<code>[:SOURce&lt;hw&gt;]:SWEep[:FREQuency]:MARKer&lt;ch&gt;:FSTate</code> .....	689

---

### **`:SWEep:TYPE` <SweepType>**

Provided for compatibility between SCPI and Rohde & Schwarz commands.

#### **Parameters:**

<SweepType>            ADVanced | STANdard  
 \*RST:                    n.a. (factory preset: STANdard)

---

### **`[:SOURce<hw>]:SWEep:POWer:DWELI` <Dwell>**

Sets the dwell time for a level sweep step.

#### **Parameters:**

<Dwell>                    float  
                               Range:        0.001 to 100  
                               Increment: 100E-6  
                               \*RST:        0.01

**Example:**                See [Example "Setup an RF frequency or power sweep"](#) on page 676.

**Manual operation:**    See "[Dwell Time](#)" on page 190

---

### **`[:SOURce<hw>]:SWEep:GENeration` <SweepType>**

Selects frequency sweep type.

#### **Parameters:**

<SweepType>            STEPped | ANALog  
                               **STEPped**  
                               Performs a frequency sweep.

**ANALog**

Performs a continuous analog frequency sweep (ramp), synchronized with the sweep time `[ :SOURce<hw> ] :SWEep [ :FREQuency ] :TIME`.

\*RST: STEPped

**Manual operation:** See " Sweep Type " on page 186

**[ :SOURce<hw> ] :SWEep:POWer:MODE <Mode>**

Sets the cycle mode for the level sweep.

**Parameters:**

<Mode> AUTO | MANual | STEP

**AUTO**

Each trigger triggers exactly one complete sweep.

**MANual**

The trigger system is not active. You can trigger every step individually with the command `[ :SOURce<hw> ] :POWer:MANual`. The level value increases at each step by the value that you define with `[ :SOURce<hw> ] :POWer:STEP [ :INCRement ]`. Values directly entered with the command `[ :SOURce<hw> ] :POWer:MANual` are not taken into account.

**STEP**

Each trigger triggers one sweep step only. The level increases by the value entered with `[ :SOURce<hw> ] :POWer:STEP [ :INCRement ]`.

\*RST: AUTO

**Example:** See [Example "Setup an RF frequency or power sweep"](#) on page 676.

**Manual operation:** See "Mode" on page 187

**[ :SOURce<hw> ] :SWEep:POWer:POINts <Points>**

Sets the number of steps within the RF level sweep range.

See [Chapter 7.2.1, "Correlating Parameters in Sweep Mode"](#), on page 179.

**Parameters:**

<Points> integer  
Range: 2 to Max

**Example:** See [Example "Setup an RF frequency or power sweep"](#) on page 676.

**[ :SOURce<hw> ] :SWEep:POWer:SPACing:MODE?**

Queries the level sweep spacing. The sweep spacing for level sweeps is always linear.

**Return values:**

<Mode> LINear  
 \*RST: LINear

**Example:**

SWE:POW:SPAC:MODE?  
 queries the sweep spacing for a level sweep at RF output.  
 Result: "LIN"  
 linear spacing

**Usage:**

Query only

**[:SOURce<hw>]:SWEep:POWer:STEP[:LOGarithmic] <Logarithmic>**

Sets a logarithmically determined step size for the RF level sweep. The level is increased by a logarithmically calculated fraction of the current level.

See [Chapter 7.2.1, "Correlating Parameters in Sweep Mode"](#), on page 179.

**Parameters:**

<Logarithmic> float  
 The unit dB is mandatory.  
 Range: 0.01 to 139 dB  
 Increment: 0.01  
 \*RST: 1  
 Default unit: dB

**Example:**

See [Example "Setup an RF frequency or power sweep"](#) on page 676.

**Manual operation:** See "[Step](#)" on page 195

**[:SOURce<hw>]:SWEep[:FREQuency]:DWEll <Dwell>**

Sets the dwell time for a frequency sweep step.

**Parameters:**

<Dwell> float  
 Range: 0.001 to 100  
 Increment: 100E-6  
 \*RST: 0.01

**Example:**

See [Example "Setup an RF frequency or power sweep"](#) on page 676.

**Manual operation:** See "[Dwell Time](#)" on page 190

**[:SOURce<hw>]:SWEep[:FREQuency]:MODE <Mode>**

Sets the cycle mode for the frequency sweep.

**Parameters:**

<Mode> AUTO | MANual | STEP

**AUTO**

Each trigger event triggers exactly one complete sweep.

**MANual**

The trigger system is not active. You can trigger every step individually by input of the frequencies with the command [ :

SOURce<hw>]:FREQuency:MANual.

**STEP**

Each trigger event triggers one sweep step. The frequency increases by the value entered with [ :SOURce<hw>]:SWEep[:FREQuency]:STEP[:LINear] (linear spacing) or [ :SOURce<hw>]:SWEep[:FREQuency]:STEP:LOGarithmic (logarithmic spacing).

\*RST: AUTO

**Example:** See [Example "Setup an RF frequency or power sweep"](#) on page 676.

**Manual operation:** See ["Mode"](#) on page 187

**[ :SOURce<hw>]:SWEep[:FREQuency]:POINts <Points>**

Sets the number of steps within the RF frequency sweep range.

See [Chapter 7.2.1, "Correlating Parameters in Sweep Mode"](#), on page 179.

Two separate POINts values are used for linear or logarithmic sweep spacing ( [ :SOURce<hw>]:SWEep[:FREQuency]:SPACing LIN | LOG). The command always affects the currently set sweep spacing.

**Parameters:**

<Points> integer  
Range: 2 to Max

**Example:** See [Example "Setup an RF frequency or power sweep"](#) on page 676.

**[ :SOURce<hw>]:SWEep[:FREQuency]:SPACing <Spacing>**

Selects the mode for the calculation of the frequency intervals, with which the current frequency at each step is increased or decreased.

The keyword [ :FREQuency] can be omitted; then the command is SCPI-compliant.

**Parameters:**

<Spacing> LINear | LOGarithmic

**LINear**

Sets a fixed frequency value as step width and adds it to the current frequency.

The linear step width is entered in Hz, see [ :SOURce<hw>]:SWEep[:FREQuency]:STEP[:LINear].

**LOGarithmic**

Sets a constant fraction of the current frequency as step width and adds it to the current frequency.

The logarithmic step width is entered in %, see [ :

[SOURce<hw>\]:SWEep\[:FREQuency\]:STEP:LOGarithmic.](#)

\*RST: LINear

**Example:** See [Example "Setup an RF frequency or power sweep"](#) on page 676.

**Manual operation:** See "[Spacing](#)" on page 190

**[ :SOURce<hw>]:SWEep:POWer:SHAPe <Shape>**

**[ :SOURce<hw>]:SWEep[:FREQuency]:SHAPe <Shape>**

Determines the waveform shape for a frequency sweep sequence.

**Parameters:**

<Shape> SAWTooth | TRIangle

\*RST: SAWTooth

**Example:** See [Example "Setup an RF frequency or power sweep"](#) on page 676.

**Manual operation:** See "[Shape](#)" on page 189

**[ :SOURce<hw>]:SWEep:POWer:EXECute**

**[ :SOURce<hw>]:SWEep[:FREQuency]:EXECute**

Executes an RF frequency sweep.

The command performs a single sweep and is therefore only effective in manual sweep mode.

**Example:** See [Example "Setup an RF frequency or power sweep"](#) on page 676.

**Usage:** Event

**Manual operation:** See "[Execute Single Sweep](#)" on page 191

**[ :SOURce<hw>]:SWEep:POWer:RETRace <State>**

**[ :SOURce<hw>]:SWEep[:FREQuency]:RETRace <State>**

Activates that the signal changes to the start frequency value while it is waiting for the next trigger event.

You can enable this feature, when you are working with sawtooth shapes in sweep mode "Single" or "External Single".

**Parameters:**

<State> 0 | 1 | OFF | ON

\*RST: 0

**Example:** See [Example "Setup an RF frequency or power sweep"](#) on page 676.

**Manual operation:** See ["Retrace"](#) on page 188

**[:SOURce<hw>]:SWEep:POWer:RUNNing?**  
**[:SOURce<hw>]:SWEep[:FREQUency]:RUNNing?**

Queries the current sweep state.

**Return values:**

<State> 0 | 1 | OFF | ON

**Example:** See [Example "Setup an RF frequency or power sweep"](#) on page 676.

**Usage:** Query only

**[:SOURce<hw>]:SWEep[:FREQUency]:STEP:LOGarithmic <Logarithmic>**

Sets a logarithmically determined step width for the RF frequency sweep. The value is added at each sweep step to the current frequency.

See [Chapter 7.2.1, "Correlating Parameters in Sweep Mode"](#), on page 179.

**Parameters:**

<Logarithmic> float  
 The unit is mandatory.  
 Range: 0.01 to 100  
 Increment: 1E-3  
 \*RST: 1  
 Default unit: PCT

**Example:** See [Example "Setup an RF frequency or power sweep"](#) on page 676.

**Manual operation:** See [" Step Linear/Step Logarithmic "](#) on page 193

**[:SOURce<hw>]:SWEep[:FREQUency]:STEP[:LINear] <Linear>**

Sets the step width for linear sweeps.

See [Chapter 7.2.1, "Correlating Parameters in Sweep Mode"](#), on page 179.

Omit the optional keywords so that the command is SCPI-compliant.

**Parameters:**

<Linear> float  
 Range: 0.001 Hz to (STOP - START)  
 Increment: 0.01

**Example:** See [Example "Setup an RF frequency or power sweep"](#) on page 676.



**Manual operation:** See " [Step Linear/Step Logarithmic](#) " on page 193

---

**[:SOURce<hw>]:COMBined:FREQUENCY:START** <CombFreqStart>

Sets the start frequency of the combined RF frequency / level sweep.

See [Chapter 7.2.1, "Correlating Parameters in Sweep Mode"](#), on page 179.

**Parameters:**

<CombFreqStart> float  
 Range: -59999E5 to 12E9  
 Increment: 0.01  
 \*RST: 100E6

**Example:** See [Example "Setup an RF frequency or power sweep"](#) on page 676.

**Manual operation:** See " [Start Frequency/Stop Frequency](#) " on page 192

---

**[:SOURce<hw>]:COMBined:FREQUENCY:STOP** <CombFreqStop>

Sets the end frequency of the combined RF frequency / level sweep.

**Parameters:**

<CombFreqStop> float  
 Range: -59999E5 to 12E9  
 Increment: 0.01  
 \*RST: 500E6

**Example:** See [Example "Setup an RF frequency or power sweep"](#) on page 676.

**Manual operation:** See " [Start Frequency/Stop Frequency](#) " on page 192

---

**[:SOURce<hw>]:COMBined:POWER:START** <CombPowStart>

Sets the start level value of the combined RF frequency / level sweep.

See [Chapter 7.2.1, "Correlating Parameters in Sweep Mode"](#), on page 179.

**Parameters:**

<CombPowStart> float  
 Range: -245 to 120  
 Increment: 0.01  
 \*RST: -30

**Example:** See [Example "Setup an RF frequency or power sweep"](#) on page 676.

**Manual operation:** See " [Start Level / Stop Level](#) " on page 194

---

**[ :SOURce<hw>]:COMBined:POWer:STOP <CombPowStop>**

Sets the stop level value of the combined RF frequency / level sweep.

**Parameters:**

<CombPowStop>	float
	Range: -245 to 120
	Increment: 0.01
	*RST: -10

**Example:** See [Example "Setup an RF frequency or power sweep"](#) on page 676.

**Manual operation:** See "[Start Level / Stop Level](#)" on page 194

---

**[ :SOURce<hw>]:SWEep:COMBined:COUNT <StepCount>**

Defines the number of sweeps you want to execute.

This parameter applies to `[ :SOURce<hw>]:SWEep:COMBined:MODE > SINGLE`. To start the sweep signal generation, use the command `[ :SOURce<hw>]:SWEep:COMBined:EXECute` on page 686.

**Parameters:**

<StepCount>	integer
	Range: 1 to SeMAX_INT_STEP-1
	*RST: 501

**Example:** See [Example "Setup an RF frequency or power sweep"](#) on page 676.

**Manual operation:** See "[Step Count](#)" on page 195

---

**[ :SOURce<hw>]:SWEep:COMBined:DWELI <Dwell>**

Sets the dwell time for the combined frequency / level sweep.

**Parameters:**

<Dwell>	float
	Range: 0.01 to 100
	Increment: 100E-6
	*RST: 0.01

**Example:** See [Example "Setup an RF frequency or power sweep"](#) on page 676.

**Manual operation:** See "[Dwell Time](#)" on page 190

---

**[ :SOURce<hw>]:SWEep:COMBined:EXECute**

Executes an RF frequency / level sweep cycle.

The command triggers one single sweep manually. Therefore, you can use it in manual sweep mode, selected with the command `[ :SOURce<hw> ] :SWEep:COMBined:MODE > MANual`.

**Example:** See [Example "Setup an RF frequency or power sweep"](#) on page 676.

**Usage:** Event

**Manual operation:** See ["Execute Single Sweep"](#) on page 191

**[ :SOURce<hw> ] :SWEep:COMBined:MODE <SweepCombMode>**

Sets the cycle mode for the combined frequency / level sweep.

**Parameters:**

<SweepCombMode> AUTO | MANual | STEP

**AUTO**

Each trigger event triggers exactly one complete sweep.

**MANual**

The trigger system is not active. You can trigger every step individually by input of the frequencies with the commands `[ :SOURce<hw> ] :FREQuency:MANual` and `[ :SOURce<hw> ] :POWer:MANual`.

**STEP**

Each trigger event triggers one sweep step.

\*RST: AUTO

**Example:** See [Example "Setup an RF frequency or power sweep"](#) on page 676.

**Manual operation:** See ["Mode"](#) on page 187

**[ :SOURce<hw> ] :SWEep:COMBined:RETRace <RetraceState>**

Activates that the signal changes to the start level value while it is waiting for the next trigger event.

You can enable this feature, when you are working with sawtooth shapes in sweep mode "Single" or "External Single".

**Parameters:**

<RetraceState> 0 | 1 | OFF | ON

\*RST: 0

**Example:** See [Example "Setup an RF frequency or power sweep"](#) on page 676.

**Manual operation:** See ["Retrace"](#) on page 188

---

**[ :SOURce<hw> ] :SWEep:COMBined:SHAPE <Shape>**

Selects the waveform shape for the combined frequency / level sweep sequence.

**Parameters:**

<Shape>                   SAWTooth | TRIangle  
\*RST:                   SAWTooth

**Example:**                See [Example "Setup an RF frequency or power sweep"](#)  
on page 676.

**Manual operation:**    See "[Shape](#)" on page 189

---

**[ :SOURce<hw> ] :SWEep:RESet[:ALL]**

Resets all active sweeps to the starting point.

**Usage:**                   Event

**Manual operation:**    See "[Reset Sweep](#)" on page 191

---

**[ :SOURce<hw> ] :SWEep[:FREQuency]:TIME <Time>**

Sets the duration of a frequency ramp sweep step.

**Parameters:**

<Time>                   float  
Range:                   0.01 to 100  
Increment:               1E-4  
\*RST:                   0.015  
Default unit: s

**Example:**                SOURce1:SWEep:FREQuency:SPACing RAMP  
SOURce1:SWEep:FREQuency:TIME 0.020

**Options:**                R&S SMAB-B28

**Manual operation:**    See "[Sweep Time](#)" on page 190

---

**[ :SOURce<hw> ] :SWEep:MARKer:OUTPut:POLarity <Polarity>**

Selects the polarity of the marker signal.

**Parameters:**

<Polarity>                NORMal | INVerted  
**NORMal**  
Marker level is high when after reaching the mark.  
**INVerted**  
Marker level is low after reaching the mark.  
\*RST:                   NORMal

**Example:**                See [\[ :SOURce<hw> \] :SWEep \[ :FREQuency \] :MARKer<ch> :FREQuency](#) on page 689.

**Options:** R&S SMAB-B28

**Manual operation:** See "[Marker Polarity](#)" on page 199

**[ :SOURce<hw>]:SWEep[:FREQUENCY]:MARKer:ACTive <Active>**

Defines the marker signal to be output with a higher voltage than all other markers.

**Parameters:**

<Active> NONE | M01 | M02 | M03 | M04 | M05 | M06 | M07 | M08 | M09 | M10  
 \*RST: NONE

**Example:** See [\[ :SOURce<hw>\]:SWEep\[:FREQUENCY\]:MARKer<ch>:FREQUENCY](#) on page 689.

**Options:** R&S SMAB-B28

**Manual operation:** See "[Active Marker](#)" on page 199

**[ :SOURce<hw>]:SWEep[:FREQUENCY]:MARKer<ch>:FREQUENCY <Frequency>**

Sets the frequency of the selected marker.

**Suffix:**

<ch> 1 to 10  
 Marker

**Parameters:**

<Frequency> float  
 Increment: 0.01  
 \*RST: 100 + n\* 100

**Example:**

```
SOURce1:SWEep:MARKer:OUTPut:POLarity NORMal
three markers at 1 GHz, 2 GHz and 3 GHz
SOURce1:SWEep:FREQUENCY:MARKer1:FREQUENCY
1000000000
SOURce1:SWEep:FREQUENCY:MARKer2:FREQUENCY
2000000000
SOURce1:SWEep:FREQUENCY:MARKer3:FREQUENCY
3000000000
SOURce1:SWEep:FREQUENCY:MARKer1:FSTate 1
SOURce1:SWEep:FREQUENCY:MARKer2:FSTate 1
SOURce1:SWEep:FREQUENCY:MARKer3:FSTate 1
SOURce1:SWEep:FREQUENCY:MARKer:ACTive M03
```

**Options:** R&S SMAB-B28

**Manual operation:** See "[Frequency x](#)" on page 198

**[ :SOURce<hw>]:SWEep[:FREQUENCY]:MARKer<ch>:FSTate <FState>**

Activates the selected marker.

<b>Suffix:</b>	
<ch>	1 to 10 Marker
<b>Parameters:</b>	
<FState>	0   1   OFF   ON
*RST:	0
<b>Example:</b>	See [:SOURCE<hw>]:SWEep[:FREQuency]:MARKer<ch>: FREQuency on page 689.
<b>Options:</b>	R&S SMAB-B28
<b>Manual operation:</b>	See "State" on page 198

## 14.17 SYSTEM Subsystem

The SYSTEM subsystem contains a series of commands for general functions which do not directly affect signal generation.

### Example: Retrieving information on network-related settings

```

SYSTEM:COMMunicate:NETWork:STATus?
// 1
SYSTEM:PROTection1:STATe 0,123456

SYSTEM:COMMunicate:NETWork:IPAddress:MODE STAT
SYSTEM:COMMunicate:NETWork:IPAddress "10.113.0.104"
SYSTEM:COMMunicate:NETWork:IPAddress:DNS "10.0.2.166"
SYSTEM:COMMunicate:NETWork:COMMON:HOSTname?
// "SMA100B-102030"
SYSTEM:COMMunicate:NETWork:COMMON:WORKgroup "instrument"
SYSTEM:COMMunicate:NETWork:COMMON:DOMain "rsint.net"
SYSTEM:COMMunicate:NETWork:IPAddress:GATeway "10.113.0.1"
SYSTEM:COMMunicate:NETWork:IPAddress:SUBNet:MASK "255.255.252.0"
SYSTEM:COMMunicate:NETWork:MACaddress "08 00 27 a3 a1 70"
SYSTEM:PROTection1:STATe 1

```

### Example: Finding out the used VISA resource strings

```

SYSTEM:COMMunicate:NETWork:RESource?
// "TCPIP::10.113.0.104::inst0::INSTR"

SYSTEM:COMMunicate:HISLip:RESource?
// "TCPIP::10.113.0.104::hislip0::INSTR"

SYSTEM:COMMunicate:SOCKet:RESource?
// "TCPIP::10.113.0.104::5025::SOCKET"
SYSTEM:COMMunicate:USB:RESource?
// "USB::0x0AAD::0x01DD::100001::INSTR"

```

```

SYSTem:COMMunicate:GPIB:RESource?
// "GPIB::28::INSTR"
SYSTem:COMMunicate:GPIB:SELF:ADDRESS?
// 28
SYSTem:COMMunicate:GPIB:LTERminator?
// STAN

```

```

SYSTem:COMMunicate:SERial:RESource?
// "ASRL1::INSTR"
SYSTem:COMMunicate:SERial:SBITs?
// 1
SYSTem:COMMunicate:SERial:BAUD?
// 115200
SYSTem:COMMunicate:SERial:PARity?
// NONE

```

### Example: Querying the error queue

```

SYSTem:ERRor:STATic?
// -221,"Settings conflict", 153,"Input voltage out of range", ...
// returns all static errors that are collected in the error queue

```

```

SYSTem:ERRor:HISTory:CLear
// deletes the history entries

```

:SYSTem:ERRor:ALL?	693
:SYSTem:ERRor:CODE:ALL?	693
:SYSTem:ERRor:CODE[:NEXT]?	694
:SYSTem:ERRor:COUNT?	694
:SYSTem:ERRor[:NEXT]?	694
:SYSTem:ERRor:GNEXt?	695
:SYSTem:ERRor:HISTory:CLear	695
:SYSTem:ERRor:STATic?	695
:SYSTem:DLOCK	696
:SYSTem:KLOCK	696
:SYSTem:NINFormation?	696
:SYSTem:ULOCK	696
:SYSTem:LOCK:OWNer?	697
:SYSTem:LOCK:RELease:ALL	697
:SYSTem:LOCK:REQuest[:EXCLusive]?	697
:SYSTem:SAV	698
:SYSTem:RCL	698
:SYSTem:PROTect<ch>[:STATe]	698
:SYSTem:SECurity:VOLMode[:STATe]	699
:SYSTem:COMMunicate:GPIB:LTERminator	699
:SYSTem:COMMunicate:GPIB:RESource?	700
:SYSTem:COMMunicate:GPIB[:SELF]:ADDRESS	700
:SYSTem:COMMunicate:HISlip:RESource?	700
:SYSTem:COMMunicate:NETWork:IPAdDress	700
:SYSTem:COMMunicate:NETWork:IPAdDress:MODE	701
:SYSTem:COMMunicate:NETWork:MACAdDress	701

:SYSTem:COMMunicate:NETWork:RESource?	701
:SYSTem:COMMunicate:NETWork:REStart	702
:SYSTem:COMMunicate:NETWork:STATus?	702
:SYSTem:COMMunicate:NETWork[:COMMon]:DOMain	702
:SYSTem:COMMunicate:NETWork[:COMMon]:HOSTname	702
:SYSTem:COMMunicate:NETWork[:COMMon]:WORKgroup	703
:SYSTem:COMMunicate:NETWork[:IPADdress]:DNS	703
:SYSTem:COMMunicate:NETWork[:IPADdress]:GATeway	703
:SYSTem:COMMunicate:NETWork[:IPADdress]:SUBNet:MASK	703
:SYSTem:COMMunicate:SERial:BAUD	703
:SYSTem:COMMunicate:SERial:PARity	704
:SYSTem:COMMunicate:SERial:RESource?	704
:SYSTem:COMMunicate:SERial:SBITs	704
:SYSTem:COMMunicate:SOCKet:RESource?	704
:SYSTem:COMMunicate:USB:RESource?	705
:SYSTem:HELP:EXPort	705
:SYSTem:IDENtification	705
:SYSTem:IDENtification:PRESet	706
:SYSTem:IRESpone	706
:SYSTem:ORESpone	706
:SYSTem:LANGuage	707
:SYSTem:INFormation:SCPI	707
:SYSTem:SECurity:SANitize[:STATe]	707
:SYSTem:SECurity:SUPolicy	707
:SYSTem:SPECification?	707
:SYSTem:SPECification:VERsion	708
:SYSTem:SPECification:IDENtification:CATalog?	709
:SYSTem:SPECification:PARAmeter?	709
:SYSTem:SPECification:VERsion:CATalog?	709
:SYSTem:SPECification:VERsion:FACTory?	710
:SYSTem:SRData?	710
:SYSTem:STARtup:COMPLete?	710
:SYSTem:DATE	710
:SYSTem:NTP:HOSTname	711
:SYSTem:NTP:STATe	711
:SYSTem:TIME	711
:SYSTem:TIME:ZONE	712
:SYSTem:TIME:ZONE:CATalog?	712
:SYSTem:UPTime?	712
:SYSTem:BIOS:VERsion?	712
:SYSTem:VERsion?	713
:SYSTem:OSYStem?	713
:SYSTem:MMEMory:PATH:USER?	713
:SYSTem:DFPR?	713
:SYSTem:REBoot	714
:SYSTem:REStart	714
:SYSTem:SHUTdown	714
:SYSTem:WAIT	714
:SYSTem:FILEs:TEMPorary:DELeTe	714



---

**:SYSTem:ERRor:ALL?**

Queries the error/event queue for all unread items and removes them from the queue.

**Return values:**

<All> string  
 Error/event\_number,"Error/event\_description>[;Device-dependent info]"  
 A comma separated list of error number and a short description of the error in FIFO order.  
 If the queue is empty, the response is 0, "No error"  
 Positive error numbers are instrument-dependent. Negative error numbers are reserved by the SCPI standard.  
 Volatile errors are reported once, at the time they appear. Identical errors are reported repeatedly only if the original error has already been retrieved from (and hence not any more present in) the error queue.

**Example:**

```
SYST:ERR:ALL?
```

Queries all entries in the error queue.

Response: 0, 'no error'

No errors have occurred since the error queue was last read out.

**Usage:**

Query only

**Manual operation:** See "[Clear History](#)" on page 729

---

**:SYSTem:ERRor:CODE:ALL?**

Queries the error numbers of all entries in the error queue and then deletes them.

**Return values:**

<All> string  
 Returns the error numbers. To retrieve the entire error text, send the command `:SYSTem:ERRor:ALL?`.  
**0**  
 "No error", i.e. the error queue is empty  
**Positive value**  
 Positive error numbers denote device-specific errors  
**Negative value**  
 Negative error numbers denote error messages defined by SCPI.

**Example:**

```
SYST:ERR:CODE:ALL
```

Queries all entries in the error queue.

Response: 0

No errors have occurred since the error queue was last read out.

**Usage:**

Query only

---

**:SYSTem:ERRor:CODE[:NEXT]?**

Queries the error number of the oldest entry in the error queue and then deletes it.

**Return values:**

<Next> string  
Returns the error number. To retrieve the entire error text, send the command `:SYSTem:ERRor:ALL?`.

**0**

"No error", i.e. the error queue is empty

**Positive value**

Positive error numbers denote device-specific errors

**Negative value**

Negative error numbers denote error messages defined by SCPI.

**Example:**

`SYST:ERR:CODE`

Queries the oldest entry in the error queue.

Response: 0

No errors have occurred since the error queue was last read out.

**Usage:**

Query only

---

**:SYSTem:ERRor:COUNT?**

Queries the number of entries in the error queue.

**Return values:**

<Count> integer

**0**

The error queue is empty.

**Example:**

`SYST:ERR:COUN`

Queries the number of entries in the error queue.

Response: 1

One error has occurred since the error queue was last read out.

**Usage:**

Query only

---

**:SYSTem:ERRor[:NEXT]?**

Queries the error/event queue for the oldest item and removes it from the queue.

**Return values:**

<Next> string  
Error/event\_number,"Error/event\_description>[:Device-dependent info]"

Error number and a short description of the error.

If the queue is empty, the response is 0, "No error"

Positive error numbers are instrument-dependent. Negative error numbers are reserved by the SCPI standard.

Volatile errors are reported once, at the time they appear. Identical errors are reported repeatedly only if the original error has already been retrieved from (and hence not any more present in) the error queue.

**Example:**            `SYST:ERR?`  
 Queries the oldest entry in the error queue.  
 Response: 0, 'no error'  
 No errors have occurred since the error queue was last read out.

**Usage:**            Query only

**Manual operation:** See "[Static Errors/Error History](#)" on page 728

#### **:SYSTEM:ERROR:GNEXT?**

Similar to `:SYSTEM:ERROR[:NEXT]?`, but queries the next entry from the global persistent error/event queue.

**Return values:**

<NextGlobalError>    string  
 Error/event number, "Error/event description" [;Device dependent info]"  
 An error number and a short description of the error.  
 Positive error numbers are instrument-dependent. Negative error numbers are reserved by the SCPI standard.

**Example:**            `SYST:ERR:GNEX?`  
 Returns the next error message from the global error queue.

**Usage:**            Query only

#### **:SYSTEM:ERROR:HISTORY:CLEAR**

Clears the error history.

**Example:**            See [Example "Querying the error queue"](#) on page 691

**Usage:**            Event

**Manual operation:** See "[Clear History](#)" on page 729

#### **:SYSTEM:ERROR:STATIC?**

Returns a list of all errors existing at the time when the query is started. This list corresponds to the display on the info page under manual control.

**Return values:**

<StaticErrors>        string

**Example:**            See [Example "Querying the error queue"](#) on page 691

**Usage:**            Query only

**Manual operation:** See "[Static Errors/Error History](#)" on page 728

---

**:SYSTem:DLOCK** <DispLockStat>

Disables the manual operation via the display, including the front panel keyboard of the instrument and the Local key.

**Parameters:**

<DispLockStat>      0 | 1 | OFF | ON  
 \*RST:                n.a. (factory preset: 0)

**Example:**

SYST:DLOC ON  
 Activates the display lock. The instrument cannot be operated via the display until it has been enabled with SYST:DLOC OFF.

**Manual operation:** See "[User Interface](#)" on page 359

---

**:SYSTem:KLOCK** <State>

Disables the front panel keyboard of the instrument including the Local key.

**Parameters:**

<State>                0 | 1 | OFF | ON  
 \*RST:                n.a. (factory preset: 0)

**Example:**

SYST:KLOC ON  
 Locks the front panel and external controls.  
 To enable the controls, send SYST:KLOC OFF.

**Manual operation:** See "[User Interface](#)" on page 359

---

**:SYSTem:NINformation?**

Queries the oldest information message ("Error History > Level > Info") in the error/event queue.

**Return values:**

<NextInfo>            string

**Example:**

:SYSTem:NINformation?  
 Queries the oldest entry in the info message queue.  
 Response: 90,"Info;=== Instrument startup...  
 ==="  
 Information message containing error number 90, that states, that the instrument startup is complete.

**Usage:**                Query only

---

**:SYSTem:ULOCK** <Mode>

Locks or unlocks the user interface of the instrument.

**Parameters:**

<Mode>                ENABled | DONLy | DISAbled | TOFF | VNConly

**ENABLEd**

Unlocks the display, the touchscreen and all controls for the manual operation.

**DONLy**

Locks the touchscreen and controls for the manual operation of the instrument. The display shows the current settings.

**VNConly**

Locks the touchscreen and controls for the manual operation, and enables remote operation over VNC. The display shows the current settings.

**TOFF**

Locks the touchscreen for the manual operation of the instrument. The display shows the current settings.

**DISabled**

Locks the display, the touchscreen and all controls for the manual operation.

\*RST: n.a. (factory preset: ENABLEd)

**Example:** `:SYST:ULOC DIS`  
Activates the user interface lock, including display and controls.

**Manual operation:** See "[User Interface](#)" on page 359

**:SYSTem:LOCK:OWNer?**

Queries the sessions that have locked the instrument currently.

If an exclusive lock is set, the query returns the owner of this exclusive lock, otherwise it returns `NONE`.

**Return values:**

<Owner> string

**Example:** `SYST:LOCK:OWN?`  
Returns the owner of locking.  
Response: `NONE`  
The instrument is not locked.

**Usage:** Query only

**:SYSTem:LOCK:RELease:ALL**

Revokes the exclusive access to the instrument.

**Usage:** Setting only

**:SYSTem:LOCK:REQuest[:EXCLusive]?**

Queries whether a lock for exclusive access to the instrument via ethernet exists. If successful, the query returns a 1, otherwise 0.

**Return values:**

<Success> integer

**Example:**

```
SYST:LOCK:REQ?
```

Queries the state of exclusive locking.

Response: 1

The exclusive locking is active.

**Usage:**

Query only

**:SYSTem:SAV <Pathname>**

Saves the current R&S SMA100B settings into a file with defined filename and into a specified directory. The file extension (\*.savrc1txt) is assigned automatically.

**Setting parameters:**

<Pathname> string

**Example:**

```
SYSTem:SAV "/var/user/temp/Test"
```

Saves the file Test.savrc1txt into the directory /var/user/temp/.

**Usage:**

Setting only

**:SYSTem:RCL <Pathname>**

Loads a file with previously saved R&S SMA100B settings.

Loads the selected file with previously saved R&S SMA100B settings from the default or the specified directory. Loaded are files with extension \*.savrc1txt.

**Setting parameters:**

<Pathname> string

**Example:**

```
SYSTem:RCL "/var/user/temp/Test"
```

Loads the file Test.savrc1txt from the directory /var/user/temp/.

**Usage:**

Setting only

**:SYSTem:PROTECT<ch>[:STATe] <State>[, <Key>]**

Activates and deactivates the specified protection level.

**Suffix:**

<ch> Indicates the protection level.  
See also "[Protection](#)" on page 353

**Parameters:**

<State> 0 | 1 | OFF | ON

\*RST: n.a. (factory preset: 1)

**Setting parameters:****<Key>** integer

The respective functions are disabled when the protection level is activated. No password is required for activation of a level. A password must be entered to deactivate the protection level. The default password for the first level is 123456. This protection level is required to unlock internal adjustments for example.

**Example:**

To activate protection level:

SYSTem:PROTect1:STATe 1

Internal adjustments or hostname cannot be changed.

To unlock protection level 1:

SYSTem:PROTect1:STATe 0,123456

Internal adjustments are accessible.

**Manual operation:** See "[Protection Level/Password](#)" on page 355**:SYSTem:SECurity:VOLMode[:STATe] <SecPassWord>, <MmemProtState>**

Activates volatile mode, so that no user data can be written to the internal memory permanently.

To enable volatile mode, reboot the instrument. Otherwise the change has no effect.

**Parameters:****<MmemProtState>** 0 | 1 | OFF | ON

\*RST: 0

**Setting parameters:****<SecPassWord>** string

Current security password

The default password is 123456.

**Example:**

SYSTem:SECurity:VOLMode:STATe "123456", 1

SYSTem:REBoot

**Manual operation:** See "[Volatile Mode](#)" on page 358**:SYSTem:COMMunicate:GPIB:LTERminator <LTerminator>**

Sets the terminator recognition for remote control via GPIB interface.

**Parameters:****<LTerminator>** STANdard | EOI**EOI**

Recognizes an LF (Line Feed) as the terminator only when it is sent with the line message EOI (End of Line). This setting is recommended particularly for binary block transmissions, as binary blocks may coincidentally contain a character with value LF (Line Feed), although it is not determined as a terminator.

**STANdard**

Recognizes an LF (Line Feed) as the terminator regardless of whether it is sent with or without EOI.

\*RST: n.a. (factory preset: STANdard)

**Example:** See [Example "Finding out the used VISA resource strings"](#) on page 690.

**:SYSTem:COMMunicate:GPIB:RESource?**

Queries the visa resource string for remote control via the GPIB interface.

To change the GPIB address, use the command `:SYSTem:COMMunicate:GPIB[:SELF]:ADDRess`.

**Return values:**

<Resource> string

**Example:** See [Example "Finding out the used VISA resource strings"](#) on page 690.

**Usage:** Query only

**:SYSTem:COMMunicate:GPIB[:SELF]:ADDRess <Address>**

Sets the GPIB address.

**Parameters:**

<Address> integer  
 Range: 0 to 30  
 \*RST: 28

**Example:** See [Example "Finding out the used VISA resource strings"](#) on page 690.

**:SYSTem:COMMunicate:HISLip:RESource?**

Queries the VISA resource string. This string is used for remote control of the instrument with HiSLIP protocol.

**Return values:**

<Resource> string

**Example:** See [Example "Finding out the used VISA resource strings"](#) on page 690.

**Usage:** Query only

**:SYSTem:COMMunicate:NETWork:IPADdress <IpAddress>**

Sets the IP address.



**Parameters:**

<IpAddress> string  
 Range: 0.0.0.0. to ff.ff.ff.ff

**Example:** See [Example "Retrieving information on network-related settings"](#) on page 690.

**Manual operation:** See ["IP Address"](#) on page 384

**:SYSTEM:COMMunicate:NETWork:IPADdress:MODE <Mode>**

Selects manual or automatic setting of the IP address.

**Parameters:**

<Mode> AUTO | STATic  
 \*RST: n.a. (factory preset: AUTO)

**Example:** See [Example "Retrieving information on network-related settings"](#) on page 690.

**Example:**  
 SYSTEM:COMMunicate:NETWork:IPADdress:MODE  
 STATic  
 SYSTEM:COMMunicate:NETWork:IPADdress  
 "10.113.0.105"

**Manual operation:** See ["Address Mode"](#) on page 384

**:SYSTEM:COMMunicate:NETWork:MACaddress <MacAddress>**

Queries the MAC address of the network adapter.

This is a password-protected function. Unlock the protection level 1 to access it.

**Parameters:**

<MacAddress> string

**Example:** See [Example "Retrieving information on network-related settings"](#) on page 690.

**Manual operation:** See ["MAC Address"](#) on page 385

**:SYSTEM:COMMunicate:NETWork:RESource?**

Queries the visa resource string for Ethernet instruments.

**Return values:**

<Resource> string

**Example:** See [Example "Finding out the used VISA ressource strings"](#) on page 690.

**Usage:** Query only

---

**:SYSTem:COMMunicate:NETWork:REStart**

Restarts the network.

**Example:**               SYSTem:COMMunicate:NETWork:REStart  
                          // Terminates the network connection and sets it up again

**Usage:**                Event

**Manual operation:**   See "[Restart Network](#)" on page 383

---

**:SYSTem:COMMunicate:NETWork:STATus?**

Queries the network configuration state.

**Return values:**  
<State>                0 | 1 | OFF | ON

**Example:**               See [Example "Retrieving information on network-related settings"](#) on page 690.

**Usage:**                Query only

**Manual operation:**   See "[Network Status](#)" on page 383

---

**:SYSTem:COMMunicate:NETWork[:COMMON]:DOMain <Domain>**

Determines the primary suffix of the network domain.

**Parameters:**  
<Domain>               string

**Example:**               See [Example "Retrieving information on network-related settings"](#) on page 690.

**Manual operation:**   See "[DNS Suffix](#)" on page 385

---

**:SYSTem:COMMunicate:NETWork[:COMMON]:HOSTname <Hostname>**

Sets an individual hostname for the Signal Generator.

**Note:**We recommend that you do not change the hostname to avoid problems with the network connection. If you change the hostname, be sure to use a unique name.

This is a password-protected function. Unlock the protection level 1 to access it.

**Parameters:**  
<Hostname>             string

**Example:**               See [Example "Retrieving information on network-related settings"](#) on page 690.

**Manual operation:**   See "[Hostname](#)" on page 384

---

**:SYSTem:COMMunicate:NETWork[:COMMON]:WORKgroup** <Workgroup>

Sets an individual workgroup name for the instrument.

**Parameters:**

<Workgroup>            string

**Example:**            See [Example "Retrieving information on network-related settings"](#) on page 690.

**Manual operation:**   See ["Workgroup"](#) on page 384

---

**:SYSTem:COMMunicate:NETWork[:IPAddress]:DNS** <DNS>

Determines or queries the network DNS server to resolve the name.

**Parameters:**

<DNS>                    string

**Example:**            See [Example "Retrieving information on network-related settings"](#) on page 690.

**Manual operation:**   See ["DNS Server"](#) on page 385

---

**:SYSTem:COMMunicate:NETWork[:IPAddress]:GATeway** <Gateway>

Sets the IP address of the default gateway.

**Parameters:**

<Gateway>                string  
Range:            0.0.0.0 to ff.ff.ff.ff

**Example:**            See [Example "Retrieving information on network-related settings"](#) on page 690.

**Manual operation:**   See ["Default Gateway"](#) on page 385

---

**:SYSTem:COMMunicate:NETWork[:IPAddress]:SUBNet:MASK** <Mask>

Sets the subnet mask.

**Parameters:**

<Mask>                    string

**Example:**            See [Example "Retrieving information on network-related settings"](#) on page 690.

**Manual operation:**   See ["Subnet Mask"](#) on page 385

---

**:SYSTem:COMMunicate:SERial:BAUD** <Baud>

Defines the baudrate for the serial remote control interface.

**Parameters:**

<Baud> 2400 | 4800 | 9600 | 19200 | 38400 | 57600 | 115200  
 \*RST: n.a. (factory preset: 115200)

**Example:** See [Example "Finding out the used VISA resource strings"](#) on page 690.

**Manual operation:** See ["Baud Rate"](#) on page 387

**:SYSTem:COMMunicate:SERial:PARity <Parity>**

Enters the parity for the serial remote control interface.

**Parameters:**

<Parity> NONE | ODD | EVEN  
 \*RST: n.a. (factory preset: NONE)

**Example:** See [Example "Finding out the used VISA resource strings"](#) on page 690.

**Manual operation:** See ["Parity"](#) on page 387

**:SYSTem:COMMunicate:SERial:RESource?**

Queries the visa resource string for the serial remote control interface. This string is used for remote control of the instrument.

**Return values:**

<Resource> string

**Example:** See [Example "Finding out the used VISA resource strings"](#) on page 690.

**Usage:** Query only

**:SYSTem:COMMunicate:SERial:SBITs <SBits>**

Defines the number of stop bits for the serial remote control interface.

**Parameters:**

<SBits> 1 | 2  
 \*RST: n.a. (factory preset: 1)

**Example:** See [Example "Finding out the used VISA resource strings"](#) on page 690.

**Manual operation:** See ["Stop Bits"](#) on page 387

**:SYSTem:COMMunicate:SOCKet:RESource?**

Queries the visa resource string for remote control via LAN interface, using TCP/IP socket protocol.

**Return values:**

&lt;Resource&gt; string

**Example:**See [Example "Finding out the used VISA resource strings"](#) on page 690.**Usage:**

Query only

**:SYSTem:COMMunicate:USB:RESource?**

Queries the visa resource string for remote control via the USB interface.

**Return values:**

&lt;Resource&gt; string

**Example:**See [Example "Finding out the used VISA resource strings"](#) on page 690.**Usage:**

Query only

**:SYSTem:HELP:EXPort**

Saves the online help as zip archive in the user directory.

**Example:**

```
:SYSTem:HELP:EXPort
MMEM:CDIR?
// "/var/user"
MMEM:CAT?
// .., "Log,DIR,4096", "help.tgz,BIN,69836600"
// confirms that help zip archive is saved.
```

**Usage:**

Event

**Manual operation::** "Setup > Help > Export Help to User Path"**:SYSTem:IDENtification <Identification>**Selects the mode to determine the "IDN String" and the "OPT String" for the instrument, selected with command `:SYSTem:LANGuage`.**Note:** While working in an emulation mode, the R&S SMA100B specific command set is disabled, that is, the SCPI command `SYST:IDEN` is discarded.**Parameters:**

&lt;Identification&gt;

AUTO | USER

**AUTO**

Automatically determines the strings.

**USER**

User-defined strings can be selected.

**\*RST:** n.a. (factory preset: AUTO)

**Example:** `SYST:IDEN AUTO`  
Automatically assigns the OPT and IDN strings according to the selected instrument language.

**Manual operation:** See "[Mode](#)" on page 388

### **:SYSTem:IDENtification:PRESet**

Sets the \*IDN and \*OPT strings in user defined mode to default values.

**Example:** `SYST:IDEN USER`  
`SYST:IDEN:PRES`

**Usage:** Event

**Manual operation:** See "[Set to Default](#)" on page 388

### **:SYSTem:IRESpone <IdnResponse>**

Defines the user defined identification string for \*IDN.

**Note:** While working in an emulation mode, the instrument's specific command set is disabled, i.e. the SCPI command `SYST:IRES` is discarded.

**Parameters:**

<IdnResponse> string

**Example:** `SYST:IDEN USER`  
`// Selects a user-defined identification`  
`SYST:IRES "Test Device"`  
`// Defines identification string 'test device'`  
`*IDN?`  
`// Response: 'test device'`

**Manual operation:** See "[IDN String](#)" on page 389

### **:SYSTem:ORESpone <OResponse>**

Defines the user defined response string for \*OPT.

**Note:** While working in an emulation mode, the instrument's specific command set is disabled, i.e. the SCPI command `SYST:ORES` is discarded.

**Parameters:**

<OResponse> string

**Example:** `SYST:IDEN USER`  
`// Selects a user-defined identification`  
`SYST:ORES "Test Option"`  
`// Defines the OPT string 'test option'`  
`*OPT?`  
`// Response: 'test option'`

**Manual operation:** See "[OPT String](#)" on page 389

---

**:SYSTem:LANGUage** <Language>

Sets the remote control command set.

**Parameters:**

<Language>            string

**Example:**

```
SYSTem:LANGUage "SCPI"  
// selects SCPI command set
```

**Manual operation:** See "[Language](#)" on page 388

---

**:SYSTem:INFormation:SCPI** <InfoString>

Inserts system information in recorded SCPI command lists, for example information on a missing command.

**Parameters:**

<InfoString>           string

**Example:**

```
SYST:INF:SCPI "missing command"  
enters the information into a recorded SCPI command list.
```

---

**:SYSTem:SECurity:SANitize[:STATE]** <SecPassWord>, <MmemProtState>

Sanitizes the internal memory.

**Parameters:**

<MmemProtState>    0 | 1 | OFF | ON  
\*RST:               0

**Setting parameters:**

<SecPassWord>       string

**Example:**

```
SYSTem:SECurity:SANitize[:STATE] 1
```

**Manual operation:** See "[Sanitize](#)" on page 358

---

**:SYSTem:SECurity:SUPolicy** <SecPassWord>, <UpdatePolicy>

Configures the automatic signature verification for firmware installation.

**Parameters:**

<UpdatePolicy>       STRict | CONFirm | IGNore  
\*RST:                n.a. (factory preset: CONFirm)

**Setting parameters:**

<SecPassWord>        string

**Manual operation:** See "[Secure Update Policy](#)" on page 356

---

**:SYSTem:SPECification?** <Id>

Retrieves data sheet information for a specific parameter.

**Setting parameters:**

<Id> string  
 Identifies the name of the entry in the data sheet, as queried with the command `:SYSTem:SPECification:IDENTification:CATalog?` on page 709

**Return values:**

<ValList> float  
 Comma-separated list with the specified and, if available, the typical value of the parameter, as specified in the data sheet. See also ["Data Sheet"](#) on page 399.

**Example:**

Retrieving instruments specification

**Note:** The following values are merely an example.

Query the data sheet versions stored in the instrument:

```
:SYSTem:SPECification:VERSion:CATalog?
"04.03,04.02,04.01,04.00,03.04,03.03,03.02,
03.01,03.00,02.96,02.95,02.94,02.02,02.01,
02.00,01.03,01.02,01.01,01.00"
```

Query the data sheet version with that the instrument was delivered:

```
:SYSTem:SPECification:VERSion:FACTory?
"04.00"
```

Select a data sheet version:

```
:SYSTem:SPECification:VERSion?
"04.00"
:SYSTem:SPECification:VERSion "04.01"
```

Selects one particular data sheet version.

Queries regarding data sheet parameters (IDs) and their values refer to this particular data sheet

Query the IDs of all parameters listed in the **selected** data sheet version:

```
:SYSTem:SPECification:IDENTification:CATalog?
"ID_RF_FREQ_SETTING_TIME_ALC_ON_MS,
ID_RF_FREQ_SETTING_TIME_MS,..."
```

Query the data sheet information on a specific parameter, defined by its ID

```
:SYSTem:SPECification?
"ID_RF_FREQ_SETTING_TIME_ALC_ON_MS"
```

Returned is the specified and, if available, the typical value of the parameter

**Usage:** Query only

---

**:SYSTem:SPECification:VERSion** <Version>

Selects a data sheet version from the data sheets saved on the instrument.

Further queries regarding the data sheet parameters (<Id>) and their values refer to the selected data sheet.



To query the list of data sheet versions, use the command `:SYSTem:SPECification:VERSion:CATalog?` on page 709.

**Parameters:**

<Version> string

**Example:** See `:SYSTem:SPECification?` on page 707.

**:SYSTem:SPECification:IDENTification:CATalog?**

Queries the parameter identifiers (<Id>) available in the data sheet.

**Return values:**

<IdList> string  
Comma-separated string of the parameter identifiers (<Id>)

**Example:** See `:SYSTem:SPECification?` on page 707.

**Usage:** Query only

**:SYSTem:SPECification:PARAmeter? <Id>[, <Parameter>]**

Retrieves data sheet information for a specific parameter.

**Setting parameters:**

<Id> string  
Identifies the name of the entry in the data sheet.  
Query the data sheet parameters with the command `:SYSTem:SPECification:IDENTification:CATalog?`.

<Parameter> float  
An additional value the result (<ValList>) depends on.

**Return values:**

<ValList> float  
Comma-separated list with the specified and, if available, the typical value of the parameter, as specified in the data sheet.

**Example:** **Note:** The following values are merely an example. Your instrument may not support the same parameters.

```
SYST:SPEC:PAR? "ID_RF_FREQ_SETTING_TIME_MS",0.1
SYST:SPEC:PAR? "ID_RF_LEVEL_MAX_GENERAL_DBM",
0.1
```

**Usage:** Query only

**:SYSTem:SPECification:VERSion:CATalog?**

Queries all data sheet versions stored in the instrument.

**Return values:**

<VersCatalog> string

**Example:** See [:SYSTem:SPECification?](#) on page 707.

**Usage:** Query only

#### **:SYSTem:SPECification:VERSion:FACTory?**

Queries the data sheet version of the factory setting.

**Return values:**

<Version> string

**Example:** See [:SYSTem:SPECification?](#) on page 707.

**Usage:** Query only

**Manual operation:** See ["Versions"](#) on page 733

#### **:SYSTem:SRData?**

Queries the SCPI recording data from the internal file.

This feature enables you to transfer an instrument configuration to other test environments, as e.g. laboratory virtual instruments.

**Return values:**

<FileData> block data

**Example:**

```
SYSTem:SRData?
// #3118:SOURcel:ROSCillator:SOURce EXT
// :SOURcel:FREQuency:CW 4000000000
// :SOURcel:FREQuency:OFFSet 1000000
// :SOURcel:AMl:STATe 1
// :OUTPut1:STATe 1
```

**Usage:** Query only

#### **:SYSTem:STARtup:COMPLete?**

Queries if the startup of the instrument is completed.

**Return values:**

<Complete> 0 | 1 | OFF | ON  
\*RST: 0

**Example:**

```
SYST:STAR:COMP?
Response: 1
the startup of the instrument is completed.
```

**Usage:** Query only

#### **:SYSTem:DATE <Year>, <Month>, <Day>**

Queries or sets the date for the instrument-internal calendar.

This is a password-protected function. Unlock the protection level 1 to access it.

**Parameters:**

<Year>	integer	
<Month>	integer	
	Range:	1 to 12
<Day>	integer	
	Range:	1 to 31

**Example:**           :SYSTem:DATE?  
                      // 2016,05,01

**Manual operation:** See ["Date"](#) on page 740

**:SYSTem:NTP:HOSTName <NTPName>**

Sets the address of the NTP server. You can enter the IP address, or the hostname of the time server, or even set up an own vendor zone. See the Internet for more information on NTP.

**Parameters:**

<NTPName>           string

**Manual operation:** See ["NTP Address"](#) on page 741

**:SYSTem:NTP:STATe <UseNtpState>**

Activates clock synchronization via NTP.

**Parameters:**

<UseNtpState>       0 | 1 | OFF | ON  
\*RST:                n.a. (factory preset: 0)

**Example:**           SYSTem:NTP:STATe 1

**Manual operation:** See ["Use Time from NTP Server"](#) on page 741

**:SYSTem:TIME <Hour>, <Minute>, <Second>**

Queries or sets the time for the instrument-internal clock.

This is a password-protected function. Unlock the protection level 1 to access it.

**Parameters:**

<Hour>	integer	
	Range:	0 to 23
<Minute>	integer	
	Range:	0 to 59
<Second>	integer	
	Range:	0 to 59

**Example:**                `SYSTem:TIME?`  
                             `// 10,27,14`

**Manual operation:**    See "Time" on page 740

---

**:SYSTem:TIME:ZONE** <TimeZone>

Sets the timezone. You can query the list of the available timezones with `:SYSTem:TIME:ZONE:CATalog?`.

**Parameters:**

<TimeZone>                string

**Manual operation:**    See "Timezone" on page 741

---

**:SYSTem:TIME:ZONE:CATalog?**

Queries the list of available timezones.

**Return values:**

<Catalog>

**Usage:**                    Query only

**Manual operation:**    See "Timezone" on page 741

---

**:SYSTem:UPTime?**

Queries the up time of the operating system.

**Return values:**

<UpTime>                    "<ddd.hh:mm:ss>"

**Example:**                `SYSTem:UPTime?`  
                             Response: "0.08:11:00"

**Usage:**                    Query only

---

**:SYSTem:BIOS:VERSion?**

Queries the BIOS version of the instrument.

**Return values:**

<Version>                    string

**Example:**                `SYST:BIOS:VERS?`  
                             queries the BIOS version.  
                             Response: 123456

**Usage:**                    Query only

---

**:SYSTem:VERSion?**

Queries the SCPI version the instrument's command set complies with.

**Return values:**

<Version>                    string

**Example:**

SYST:VERS

queries the SCPI version.

Response: "1996"

The instrument complies with the SCPI version from 1996.

**Usage:**                    Query only

---

**:SYSTem:OSYStem?**

Queries the operating system of the instrument.

**Return values:**

<OperSystem>                string

**Example:**

SYSTem:OSYStem?

Response: "Linux"

**Usage:**                    Query only

---

**:SYSTem:MMEMory:PATH:USER?**

Queries the user directory, that means the directory the R&S SMA100B stores user files on.

**Return values:**

<PathUser>                   string

**Example:**

SYSTem:MMEMory:PATH:USER?

Response: "/var/user/"

**Usage:**                    Query only

---

**:SYSTem:DFPR?**

Queries the device footprint of the instrument. The retrieved information is in machine-readable form suitable for automatic further processing.

**Return values:**

<DeviceFootprint>        string

Information on the instrument type, device identification and details on the installed FW version, hardware and software options.

**Example:**

:SYSTem:DFPR?

**Usage:**                    Query only

---

---

**:SYSTem:REBoot**

Reboots the instrument including the operating system.

**Usage:** Event

---

**:SYSTem:REStArt**

Restarts the instrument without restarting the operating system.

**Usage:** Event

---

**:SYSTem:SHUTdown**

Shuts down the instrument.

**Usage:** Event

**Manual operation:** See "[Shut down](#)" on page 749

---

**:SYSTem:WAIT <TimeMs>**

Delays the execution of the subsequent remote command by the specified time.

This function is useful, for example to execute an SCPI sequence automatically but with a defined time delay between some commands.

See [Chapter 12.2.4, "How to Assign Actions to the \[★ \(User\)\] Key"](#), on page 348.

**Setting parameters:**

<TimeMs> integer  
Wait time in ms  
Range: 0 to 10000  
\*RST: 0

**Example:**  

```
:SYSTem:WAIT 10000
// waits 10s before resetting the instrument
*RST
```

**Usage:** Setting only

---

**:SYSTem:FILEs:TEMPorary:DELeTe**

Deletes the temporary files from the internal memory or, if installed, from the SD card slot.

**Example:**  

```
:SYSTem:FILEs:TEMPorary:DELeTe
// temporary files are removed
```

**Usage:** Event

---

## 14.18 STATus Subsystem

This system contains the commands for the status reporting system. See also [Chapter A.1.5, "Status Reporting System"](#), on page 763 for detailed information.

\*RST on page 438 has no effect on the status registers.

### Value ranges

- Queries return the current value of the respective register, which permits a check of the device status.  
Return values: A decimal value in the range 0 to 32767 ( $=2^{15}-1$ )
- The configuration commands set the respective register thus determining which status changes of the R&S SMA100B cause the status registers to be changed.  
Setting values: A decimal value in the range 0 to 32767 ( $=2^{15}-1$ )

:STATus:OPERation:CONDition?	715
:STATus:OPERation:ENABle	715
:STATus:OPERation[:EVENT]	716
:STATus:OPERation:NTRansition	716
:STATus:OPERation:PTRansition	716
:STATus:PRESet	716
:STATus:QUEStionable:CONDition	717
:STATus:QUEStionable:ENABle	717
:STATus:QUEStionable[:EVENT]	717
:STATus:QUEStionable:NTRansition	717
:STATus:QUEStionable:PTRansition	718
:STATus:QUEue[:NEXT]?	718

---

### :STATus:OPERation:CONDition?

Queries the content of the CONDition part of the STATus:OPERation register.

This part contains information on the action currently being performed in the instrument. The content is not deleted after being read out because it indicates the current hardware status.

#### Return values:

<Condition>            string

**Example:**                :STATus:OPERation:CONDition?

**Usage:**                    Query only

---

### :STATus:OPERation:ENABle <Enable>

Sets the bits of the ENABle part of the STATus:OPERation register. This setting determines which events of the Status-Event part are forwarded to the sum bit in the status byte. These events can be used for a service request.

#### Parameters:

<Enable>                string

**Example:**                    :STAT:OPER:ENAB 32767  
all events are forwarded to the sum bit of the status byte.

#### :STATus:OPERation[:EVENT] <Event>

Queries the content of the EVENT part of the STATus:OPERation register. This part contains information on the actions performed in the instrument since the last readout. The content of the EVENT part is deleted after being read out.

**Parameters:**

<Event>                    string

**Example:**                    :STAT:OPER:EVEN?  
queries the STATus:OPERation:EVENT register.

#### :STATus:OPERation:NTRansition <Ntransition>

Sets the bits of the NTRansition part of the STATus:OPERation register. If a bit is set, a transition from 1 to 0 in the condition part causes an entry to be made in the EVENT part of the register. The disappearance of an event in the hardware is thus registered, for example the end of an adjustment.

**Parameters:**

<Ntransition>            string

**Example:**                    :STAT:OPER:NTR 0  
a transition from 1 to 0 in the condition part of the Status:Operation register does not cause an entry to be made in the EVENT part.

#### :STATus:OPERation:PTRansition <Ptransition>

Sets the bits of the PTRansition part of the STATus:OPERation register. If a bit is set, a transition from 0 to 1 in the condition part causes an entry to be made in the EVENT part of the register. A new event in the hardware is thus registered, for example the start of an adjustment.

**Parameters:**

<Ptransition>            string

**Example:**                    :STAT:OPER:PTR 32767  
all transitions from 0 to 1 in the condition part of the Status:Operation register cause an entry to be made in the EVENT part.

#### :STATus:PRESet <Preset>

Resets the status registers. All PTRansition parts are set to FFFFh (32767), i.e. all transitions from 0 to 1 are detected. All NTRansition parts are set to 0, i.e. a transition from 1 to 0 in a CONDition bit is not detected. The ENABLE parts of STATus:OPERation and STATus:QUESTionable are set to 0, i.e. all events in these registers are not passed on.



**Parameters:**

<Preset> string

**Example:**

STAT:PRES  
resets the status registers.

**:STATus:QUESTionable:CONDition <Condition>**

Queries the content of the CONDition part of the STATus:QUESTionable register. This part contains information on the action currently being performed in the instrument. The content is not deleted after being read out since it indicates the current hardware status.

**Parameters:**

<Condition> string

**Example:**

:STATus:QUESTionable:CONDition?  
queries the Status:Questionable:Condition register.

**:STATus:QUESTionable:ENABle <Enable>**

Sets the bits of the ENABle part of the STATus:QUESTionable register. The enable part determines which events of the STATus:EVENT part are enabled for the summary bit in the status byte. These events can be used for a service request.

If a bit in the ENABle part is 1, and the corresponding EVENT bit is true, a positive transition occurs in the summary bit. This transition is reported to the next higher level.

**Parameters:**

<Enable> string

**Example:**

STAT:QUES:ENAB 1  
Problems when performing an adjustment cause an entry to be made in the sum bit.

**:STATus:QUESTionable[:EVENT] <Event>**

Queries the content of the EVENT part of the STATus:QUESTionable register. This part contains information on the actions performed in the instrument since the last readout. The content of the EVENT part is deleted after being read out.

**Parameters:**

<Event> string

**Example:**

STAT:QUES:EVENT?  
queries the Status:Questionable:Event register.

**:STATus:QUESTionable:NTRansition <Ntransition>**

Sets the bits of the NTRansition part of the STATus:QUESTionable register. If a bit is set, a transition from 1 to 0 in the condition part causes an entry to be made in the EVENT part of the register.

**Parameters:****<Ntransition>** string**Example:**

STAT:QUES:NTR 0

a transition from 1 to 0 in the condition part of the STATus:QUEStionable register does not cause an entry to be made in the EVENT part

**:STATus:QUEStionable:PTRansition <PTransition>**

Sets the bits of the NTRansition part of the STATus:QUEStionable register. If a bit is set, a transition from 1 to 0 in the condition part causes an entry to be made in the EVENT part of the register.

**Parameters:****<PTransition>** string**Example:**

STAT:QUES:PTR 32767

all transitions from 0 to 1 in the condition part of the STATus:QUEStionable register cause an entry to be made in the EVENT part

**:STATus:QUEue[:NEXT]?**

Queries the oldest entry in the error queue and then deletes it. Positive error numbers denote device-specific errors, and negative error numbers denote error messages defined by SCPI. If the error queue is empty, 0 ("No error") is returned.

The command is identical to `:SYSTem:ERRor[:NEXT]?` on page 694.

**Return values:****<Next>** string**Example:**

:STATus:QUEue?

queries the oldest entry in the error queue.

Response: 0, 'no error'

no errors have occurred since the error queue was last read out

**Usage:**

Query only

## 14.19 TEST Subsystem

The TEST subsystem contains the commands for performing test routines directly at the hardware assemblies.

The selftest responses with a 0 if the test is performed successfully, otherwise a value other than 0 is returned. None of the commands of this system has a \*RST value.

`:TEST<hw>:ALL:START.....` 719  
`:TEST<hw>:ALL:RESult?.....` 719

**:TEST<hw>:ALL:START****Usage:** EventStarts the selftest. Use the command `:TEST<hw>:ALL:RESult?` to query the result.**:TEST<hw>:ALL:RESult?**Queries the result of the performed selftest. Start the selftest with `:TEST<hw>:ALL:START`.**Return values:**

&lt;Result&gt; 0 | 1 | RUNning | STOPped

\*RST: STOPped

**Usage:** Query only

## 14.20 TRIGger Subsystem

The TRIGger system contains the commands for selecting the trigger source for the RF and LF sweep.

You can work with an internal or with an externally applied trigger signal. In this case, use the commands in the `SOURCE:INPut` subsystem to configure the signal.

The trigger system of the R&S SMA100B is a simplified implementation of the SCPI trigger system. The TRIGger system differs from the SCPI system as follows:

- No `INITiate` command; the instrument behaves as if `INITiate:CONTinuous ON` were set.
- Under TRIGger several sweep subsystems exist.
- The trigger source names correspond directly to the various settings of manual control. SCPI uses different names which are also accepted by the instrument. The SCPI names should be used if compatibility is an important consideration.

In addition to these commands, see more trigger-related commands in the modulation and RF signal subsystems.

*Table 14-1: Cross-reference between the manual and remote control*

R&S proprietary value name	SCPI conform value name	Parameter in manual control
AUTO	IMMediate	"Auto" mode
SINGLE	BUS	"Single" mode.
EXTErnal	EXTErnal	"Ext Single" and "Ext Step" mode. Use command <code>LFO:SWEep:MODE</code> to select between the two sweep modes.
EAUTO	-	"Ext Start/Stop" mode.

:TRIGger<hw>:FSweep:SOURce.....	720
:TRIGger<hw>:LFFSweep:SOURce.....	720
:TRIGger<hw>:PSweep:SOURce.....	720
:TRIGger<hw>[:SWEep]:SOURce.....	720
:TRIGger<hw>:FPSweep:SOURce.....	721
:TRIGger<hw>:FSweep[:IMMEDIATE].....	722
:TRIGger<hw>:LFFSweep:IMMEDIATE.....	722
:TRIGger<hw>:PSweep[:IMMEDIATE].....	722
:TRIGger<hw>[:SWEep][:IMMEDIATE].....	722
:TRIGger<hw>:LFFSweep.....	722

---

```

:TRIGger<hw>:FSweep:SOURce <Source>
:TRIGger<hw>:LFFSweep:SOURce <Source>
:TRIGger<hw>:PSweep:SOURce <Source>
:TRIGger<hw>[:SWEep]:SOURce <Source>

```

Selects the trigger source for the corresponding sweeps:

- FSweep - RF frequency
- LFFSweep - LF frequency
- PSweep - RF level
- SWEep - all sweeps

The source names of the parameters correspond to the values provided in manual control of the instrument. They differ from the SCPI-compliant names, but the instrument accepts both variants.

Use the SCPI name, if compatibility is an important issue. Find the corresponding SCPI-compliant commands in [Cross-reference between the manual and remote control](#).

#### Setting parameters:

```
<Source>          AUTO | IMMEDIATE | SINGLE | BUS | EXTERNAL | EAUTO
```

#### **AUTO [IMMEDIATE]**

Executes a sweep automatically.

In this free-running mode, the trigger condition is met continuously. I.e. when a sweep is completed, the next one starts immediately.

**SINGle [BUS]**

Executes one complete sweep cycle.

The following commands initiate a trigger event:

\*TRG on page 439

```
[ :SOURce<hw> ] :SWEep:POWer:EXECute
[ :SOURce<hw> ] :SWEep [ :FREQuency ] :EXECute
:TRIGger<hw> [ :SWEep ] [ :IMMediate ], :TRIGger<hw> :
PSWep [ :IMMediate ] and :TRIGger<hw> :FSWep [ :
IMMediate ].
```

Set the sweep mode with the commands:

```
[ :SOURce<hw> ] :SWEep:POWer:MODEAUTO | STEP
[ :SOURce<hw> ] :SWEep [ :FREQuency ] :MODEAUTO | STEP
[ :SOURce<hw> ] :LFOutput:SWEep [ :FREQuency ] :MODE
AUTO | STEP
```

In step mode (STEP), the instrument executes only one step.

**EXtErnal**

An external signal triggers the sweep.

**EAUTo**

An external signal triggers the sweep. When one sweep is finished, the next sweep starts.

A second trigger event stops the sweep at the current frequency, a third trigger event starts the trigger at the start frequency, and so on.

```
*RST:      AUTO
```

**Example:** See [Example "Setup an LF sweep"](#) on page 632

**Usage:** Setting only

```
:TRIGger<hw>:FPSWep:SOURce <FpTrigSource>
```

Selects the trigger source for the combined RF frequency / level sweep.

The parameter names correspond to the manual control. If needed, see [table Table 14-1](#) for selecting the trigger source with SCPI compliant parameter names.

**Parameters:**

```
<FpTrigSource> AUTO | IMMediate | SINGle | BUS | EXtErnal | EAUTo
```

**AUTO|IMMediate**

Executes the combined RF sweep automatically. In this free-running mode, the trigger condition is met continuously. I.e. as soon as a sweep is completed, the next one starts immediately.

**SINGle|BUS**

Executes one complete sweep cycle triggered by the GPIB commands [ :SOURce<hw> ] :SWEep:COMBined:EXECute or \*TRG. The mode has to be set to [ :SOURce<hw> ] :SWEep:COMBined:MODE > AUTO.

**EXtErnal**

An external signal triggers the sweep.

**EAUTO**

An external signal triggers the sweep. As soon as one sweep is finished, the next sweep starts. A second trigger event stops the sweep at the current frequency and level value pairs, a third trigger event starts the trigger at the start values, and so on.

\*RST: No enum range assigned!

**Manual operation:** See "[Mode](#)" on page 187

**:TRIGger<hw>:FSweep[:IMMEDIATE]**  
**:TRIGger<hw>:LFFSweep:IMMEDIATE**  
**:TRIGger<hw>:PSweep[:IMMEDIATE]**  
**:TRIGger<hw>[:SWEep][:IMMEDIATE]**

Performs a single sweep and immediately starts the activated, corresponding sweep:

- FSWep - RF frequency
- PSweep - RF level
- LFFSweep - LF frequency
- SWEep - all sweeps

Effective in the following configuration:

- TRIG:FSW|LFFS|PSW|[:SWE]:SOUR **SING**
- SOUR:SWE:FREQ|POW:MODE **AUTO** or SOUR:LFO:SWE:[FREQ:]MODE **AUTO**

Alternatively, you can use the IMMEDIATE command instead of the respective SWEep : [FREQ:] | POW:EXECute command.

**Example:** TRIG  
Starts all active sweeps.

**Usage:** Event

**Manual operation:** See "[Execute Single Sweep](#)" on page 191

**:TRIGger<hw>:LFFSweep**

Executes an LF frequency sweep in the following configuration:

- TRIG:LFFS:SOUR SING
- LFO:SWE:MODE AUTO

**Example:** LFO:SWE:MODE AUTO  
TRIG:LFFS:SOUR SING  
TRIG:LFFSweep

**Usage:** Event

## 14.21 UNIT Subsystem

The `UNIT` subsystem is used to set default units for parameters if no unit is indicated in a command. These settings are valid for the entire instrument.

### Example: Setting default units for remote control

```
UNIT:POW V
UNIT:ANGL DEG
```

Sets V (volts) as unit of all power parameters, DEG (degrees) for the phase modulation angle and KMH for the speed.

```
:UNIT:ANGLE.....723
:UNIT:POWer.....723
```

---

#### **:UNIT:ANGLE** <Angle>

Sets the default unit for phase modulation angle. The command affects no other parameters, such as RF phase, or the manual control or display.

#### Parameters:

```
<Angle>          DEGREE | DEGREE | RADIAN
                  *RST:      RADIAN
```

---

#### **:UNIT:POWer** <Power>

Sets the default unit for all power parameters. This setting affects the GUI, as well as all remote control commands that determine power values.

#### Parameters:

```
<Power>          V | DBUV | DBM
                  *RST:      DBM
```

# 15 Troubleshooting and Error Messages

The R&S SMA100B distinguishes between various messages such as status messages, error messages, warnings, or information that are displayed in the "Info" line on the screen, and also entered in the error/event queue of the status reporting system.

This section describes the types of error messages and warnings. The status reporting system is described in detail in [Chapter A.1.5, "Status Reporting System"](#), on page 763.

You can also access an Info window with detailed information about all messages in a history list. For details, see [Chapter 15.4, "Querying Error Messages"](#), on page 727

## 15.1 Error Messages

Error messages indicate errors in the instrument. They are displayed in different colors depending on their importance and display duration. Errors (e.g. no calibration data) are displayed in red, information (e.g. file not found) and warnings in black. Warnings indicate less significant errors (e.g. the instrument operates outside specified data).

Some error messages require that the error must be eliminated before correct instrument operation can be ensured. To access the "Info" dialog with a list of current messages and a detailed description of each message, select "Info".

In the remote control mode, error messages are entered in the error/event queue of the status reporting system and can be queried with the command `SYSTem:ERRor?`. If the error queue is empty, 0 ("No error") is returned.

### 15.1.1 Volatile Messages

Volatile messages report automatic settings in the instrument (e.g. switching off incompatible types of modulation) or on illegal entries that are not accepted by the instrument (e.g. range violations). They are displayed in the info line on a yellow background. They are displayed on top of status information or permanent messages.

Volatile messages do not normally demand user actions and disappear automatically after a brief period of time. They are stored in the history, however.

Remote command:

```
:SYSTem:ERRor:ALL? or  
:SYSTem:ERRor:CODE[:NEXT]?
```

### 15.1.2 Permanent Messages

Permanent messages are displayed if an error occurs that impairs further instrument operation, e.g. a hardware fault. The error signaled by a permanent message must be eliminated before correct instrument operation can be continued.



The message is displayed until the error is eliminated. It covers the status display in the info line. After error elimination, the message automatically disappears and is also recorded in the history.

Remote command:

```
:SYSTem:ERRor:STATic?
```

## 15.2 SCPI-Error Messages

The SCPI error messages are the same in all SCPI instruments. Detailed information and an overview of all error messages as defined in SCPI standard can be found in the corresponding documentation.

SCPI errors have negative codes (numbers). The error text being entered into the error/event queue or being displayed is printed in bold face on the left together with the error code. Below the error text, there is an explanation as to the respective error.

## 15.3 Device-Specific Error Messages

### Start-up error

If device-specific errors occur during operation, the R&S SMA100B issues corresponding error messages, as listed under [Errors during operation](#). However, problems can also occur during start-up.

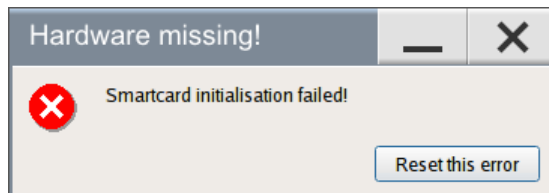

If your instrument prompts this error message when starting up, some information during initialization is missing. This error can occur when the power supply was interrupted during the last boot-up, e.g. due to power failure.

### Remedy

- ▶ Select "Reset this error".
  - If the operating system and the firmware boot successfully, the functionality is restored.
  - If the error message reappears, a hardware error has occurred. We recommend that you contact the Rohde & Schwarz customer support (<http://www.customersupport.rohdeschwarz.com>), or ship your R&S SMA100B directly to the service center experts for troubleshooting (<http://www.services.rohdeschwarz.com>).

### Errors during operation

The following table contains all error messages specific for the instrument in alphabetical order, as well as an explanation of the error situation. The positive error codes mark the errors specific to the instrument.

The device-specific error messages set bit 3 in the ESR register.



The index provides a list of the error messages sorted according to their error codes.

Error Code	Error	Description	Remedy
50	Extern reference out of range or disconnected	External reference is selected but no external signal is applied or the signal is out of range.	<ul style="list-style-type: none"> <li>Check the selected reference signal source (internal or external) in the "Setup &gt; Reference Oscillator" dialog.</li> <li>Change setting to 'internal' if no appropriate external source is available.</li> </ul>
140	This modulation forces other modulations off	A modulation has been switched on which cannot be used at the same time as an already active modulation. The previous modulation has been switched off.	
180	Adjustment failed	Adjustment could not be executed	Generate the adjustment data and load it into the device
182	Adjustment data missing	Adjustment data is missing.	Generate the adjustment data and load it into the device
183	Adjustment data invalid	Adjustment data is invalid and must be restored.	Generate the adjustment data and load it into the device
200	Cannot access hardware	The data transmission to a module was unsuccessful.	The module is not installed, not properly installed or missing.
201	Hardware revision out of date	A later version of certain parts of the instrument is necessary to execute the function selected.	The driver does not support the installed version of a module.
202	Cannot access the EEPROM	An error occurs when writing or reading a EEPROM.	The EEPROM is possibly defect. Replace it.
203	Invalid EEPROM data	Reading a EEPROM is possible, however the data are inconsistent.	
204	Driver initialization failed	Initialization of a driver fails when booting the instrument firmware.	The driver is not compatible with the hardware or software configuration of the instrument.
241	No current list	There is no list selected. To execute the required operation, a list has to be selected in the related dialog. If no list is available, a new list must be created.	
242	Unknown list type specified	The list type selected is not valid for the required operation.	Check the selected list type.
460	Cannot open the file	The selected file cannot be opened.	Check the path and file name.

Error Code	Error	Description	Remedy
461	Cannot write file	The file cannot be written.	Check if the file is read-only.
462	Cannot read file	The file cannot be read.	Check if the file contents are compatible with the file type.
463	Filename missing	The required operation cannot be executed because the file name is not specified.	Enter file name when creating list.
464	Invalid filename extension	The file extension is not valid for the required operation.	Check the file extension.
465	File contains invalid data	The selected file contains data that is not valid for the file type.  The file extension determines the data that is valid for this file type. If the file extension is changed, the lists are no longer recognized and the data is therefore invalid.	Check the file extension.

## 15.4 Querying Error Messages

The R&S SMA100B monitors the functions performed and automatically detects errors and irregularities. The instrument displays the messages in the "Info" line and records them in the background with a detailed description.

Find details to the system messages in [Chapter 15, "Troubleshooting and Error Messages"](#), on page 724.

### To display information on static errors and error history

1. In the taskbar, select the "Info" icon.
2. For some messages, the information line appears briefly on the home screen.

To open the dialog, in the "Info" line select the "Info" button.

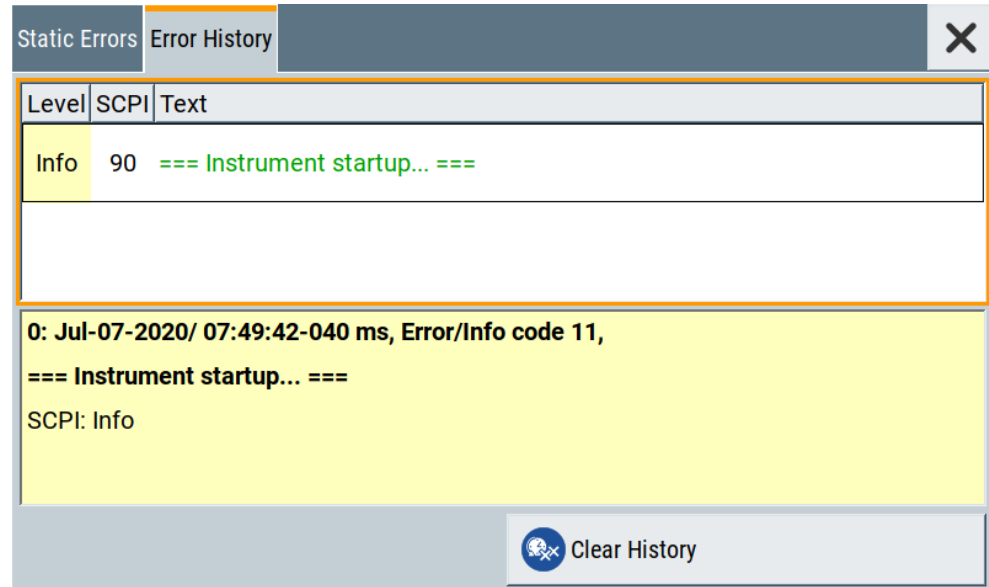

- The "Static Errors" dialog lists the last monitored messages chronologically and displays additional information on the highlighted message.
- The "Error History" dialog lists the accumulated messages with a short description. Volatile errors are reported once, at the time they appear. If identical errors occur subsequently, they are not reported repeatedly. In the "Info" line, identical errors are displayed repeatedly only if the original error has already disappeared from the display. If queried by SCPI command, identical errors are only reported if the original error has already been retrieved from (and hence not any more present in) the error queue.



### Indication and handling of permanent messages

If any critical error occurs, the R&S SMA100B automatically shows the icon in the taskbar. Select the icon to obtain information on the error and the number of occurrences.

The icon is assigned to permanent messages. The message and icon are displayed until the error is eliminated.

### Static Errors/Error History

Toggles between "Static" and "History" view of the info dialog.

Remote command:

`:SYSTem:ERRor[:NEXT]?` on page 694

Each time a `SYST:ERR:NEXT?` query is sent, the eldest entry in the error queue is returned and at the same time cleared in the list.

`:SYSTem:ERRor:STATic?` on page 695

Queries the list of all errors.

**Clear History**

Clears all messages in the "History" view.

Remote command:

`:SYSTem:ERRor:ALL?` on page 693

Each time a `SYST:ERR:ALL?` query is sent, the error queue is returned and at the same time cleared.

`:SYSTem:ERRor:HISTory:CLEar` on page 695

Clears the messages in the "History" view.

## 15.5 Resolving Network Connection Failures

Several issues may cause failures in the network connection to the instrument. This section lists the most likely reasons and the recommended solutions.

**Common reasons for network connection failures**

- Network connecting cables and cable connectors of poor quality
- Incompatibility between the network interface of the R&S SMA100B and certain switches or routers available on the market
- An invalid IP address assigned to the instrument

**Possible solutions to network connection failures**

1. **NOTICE!** Connecting to the network can cause network failure. Errors can affect the entire network.

Consult your network administrator before performing the following tasks:

- Connecting the instrument to the network
- Configuring the network
- Changing IP addresses

2. Try out the following to resolve network connection failures:

- Check the network infrastructure. Exchange connecting cables, if obvious damage is visible.  
See also "[Cable selection and electromagnetic interference \(EMI\)](#)" on page 30.
- Observe the link status LED on the R&S SMA100B or the connected network device. The link status LED is located next to the LAN connector.  
If a link failure is detected, connect the instrument to a different device port or to a different network device.
- Check whether the LAN interface and the required LAN services are enabled.  
See [Chapter 12.4.3, "Configuring LAN Services"](#), on page 361.
- If the IP address is set manually (no DHCP) or obtained via the Zeroconf (APIPA) protocol:
  - Check whether the IP address of the instrument is within the network's address range.
  - Check whether the IP address is valid.

See also "IP Address" on page 384.

## 15.6 Measuring USB cable quality

To check the quality of the USB cable, see the service manual of the R&S SMA100B.

## 15.7 Requesting Instrument Configuration and Specifications

The R&S SMA100B is equipped with various hardware and software components. To get an overview of what your instrument is equipped with, you can request the assemblies, hardware and software options, and the firmware version. The components are structured according to the hardware configuration, software options, including the license management, and externally used Rohde & Schwarz equipment, like R&S NRP power sensors.



Software options purchased at a later stage can be activated with a keycode. The activation code is supplied with the software option. How to install options is described in chapter 4 of the R&S SMA100B service manual.

The installation of hardware options purchased at a later stage is also described in chapter 4 of the service manual. Most of the hardware options have to be installed at an authorized Rohde & Schwarz service center.

### 15.7.1 Hardware Configuration Settings

Access:

- ▶ Select "System Config > Setup > Instrument Assembly > Hardware Config".

General					RF Assembly	Counter			✕
Assembly	Part Number	Serial Number	Revision	Slot					
SMA100B	1419.8888k02	0							
FRONT_AF	1419.9690.02	100000	01.00	PCI-E slot					
PSU300	2118.2067.02	100000	01.00						
IFB.BV	1423.5009.02	100000	01.00						
MB2_AF	1420.1360.02	100000	01.00						
SMAF_COM			01.00						
ADAP_CPU_AF	1420.1960.02	100000	01.00						
DCDC2_AF	1420.1860.02	100000	01.00						
IPM21	1206.3122.02	100000	01.00	PCI-E slot					
BIOS									

The "Hardware Config" dialog lists all installed assemblies and externally connected instruments with information on their part and serial numbers, and revision states. The BIOS version is also listed; firmware updates do not update the BIOS version.

The dialog is divided in tabs, according to the hardware components of the signal domains. The "Counter" tab provides information on the operation time and number of times the instrument was powered on.

The remote commands required to query the hardware configuration are described in [Chapter 14.8, "DIAGnostic Subsystem"](#), on page 459.

### Assembly

The tables in the tabs show characteristics of the installed assemblies.

"Assembly" Assembly designation.

"Part Number" Part number of the assembly.

"Serial Number" Serial number of the assembly.

"Revision" Revision state of the assembly.

"Slot" Indicates whether the assembly is connected to the serial bus or PCI bus.

Remote command:

`:DIAGnostic<hw>:BGInfo?` on page 460

### Counter

Displays information on the operation times of the R&S SMA100B.

#### Operation Time / h ← Counter

Displays the operation time in hours so far.

Remote command:

`:DIAGnostic:INFO:OTIME?` on page 461

**Power On Count ← Counter**

Displays the number the instrument has been turned on.

Remote command:

[:DIAGnostic:INFO:POCount?](#) on page 461

**Last Factory Calibration ← Counter**

Displays the date of the last factory calibration.

Remote command:

[:CALibration:DATA:FACTory:DATE?](#) on page 454

## 15.7.2 Versions/Options Settings

Access:

- ▶ Select "System Config > Setup > Instrument Assembly > Versions / Options".

Firmware	Hardware Options	Software Options	Versions
Package	Version		
FW	4.20.044		
Service Pack	not installed		
Bios Version	VirtualBox		
<b>Downgrade Info:</b>			
Package	Version		
Factory Version	4.20.044		
Min. Version	4.00.016.00		
<p>The Min. Version is the first version supporting all hardware modules installed in this instrument. Please read release notes carefully before downgrading, some software options and features may get lost.</p>			
<input type="button" value="Show Open Source Acknowledgements"/>			

The "Versions/Options" dialog shows the version of the installed instrument firmware, the hardware and software options, the data sheet and the software components of the firmware. The BIOS version is also listed; firmware updates do not update the BIOS version.

The remote commands required to query the hardware configuration are described in [Chapter 14.8, "DIAGnostic Subsystem"](#), on page 459.

**Firmware**

Shows the firmware version and the version of the software platform.

**Note:** Your instrument is delivered with the latest firmware version available.

You can download firmware updates and the "Release Notes" that describe the modifications and the firmware update procedure.

See [www.rohde-schwarz.com/firmware/sma100b](http://www.rohde-schwarz.com/firmware/sma100b)

Remote command:

n.a.



**Downgrade Info**

Shows downgrade information, like factory firmware version and minimum firmware version to that the instrument can be downgraded.

Remote command:

n.a.

**Show Open Source Acknowledgments**

Accesses the list of the used open-source software packages and the corresponding verbatim license texts.

**Hardware Options/Software Options**

The tables in the "Hardware" and "Software" tabs list the installed hardware and software options.

"Option"            Short name of option

"Designation"    Name of option

"Expiration Date"

For regular options, "Permanent" is indicated in this column. Some options are available as trial versions. This column shows their expiration date. After this date, the option is no longer available on the instrument.

Remote command:

[\\*OPT?](#) on page 437

[\\*IDN?](#) on page 436

**Versions**

The "Versions" tab shows the versions of the technical specification of the R&S SMA100B and of the software components that comprise the firmware.

"Package"            Name of the component.

"Version"            Current issue of the component.

E.g. the data sheet covers the technical data of the hardware components of the factory settings.

See also "[Data Sheet](#)" on page 399.

Remote command:

[:SYSTEM:SPECification:VERSION:FACTory?](#) on page 710

### 15.7.3 How to Query Instrument Configuration

To get information on the components and installed options of the R&S SMA100B, proceed as described in the following examples.

**Checking the installed hardware options**

To find out the installed options:

1. Select "System Config > Setup > Instrument Assembly > Versions/Options".

2. Select "Hardware Options".

Firmware	Hardware Options	Software Options	Versions	
Option	Designation			
SMAB-B28	Ramp Sweep			
SMAB-B29	Differential clock synthesizer			
SMAB-B86	Remote control GPIB USB			
SMAB-B92	Height Unit 2 HU			
SMAB-B106	Frequency range: 8 kHz to 6 GHz			

The dialog lists all hardware options that are installed on the R&S SMA100B.

Proceed the same way to get information for instance on the firmware, or the installed software options in the corresponding tab.

### Checking the RF hardware assembly

To find out the installed RF hardware:

1. Select "System Config > Setup > Instrument Assembly > Hardware Config".
2. Select "RF Assembly".

General	RF Assembly	Counter		
Assembly	Part Number	Serial Number	Revision	Slot
RSYN1_AF	1420.0570.02	100000	01.00	
SMAF_REF			01.00	
MSYN6_AF	1420.0470.02	100000	01.00	
SMAF_MOD			01.00	
CSYN_AF	1420.0470.06	100000	01.00	
SMAF_MOD			01.00	
OPU6_AF	1420.0770.02	100000	01.00	
OPU6-CPLD			01.00	
			00.00	
ATT6HP_AF	1420.2050.02	100000	01.00	
ATT6HP-CPLD			01.00	
			00.00	

The dialog lists the RF hardware components that are installed on the R&S SMA100B.

Proceed the same way to get information for instance on general or baseband hardware modules, or on the operating times of the R&S SMA100B in the corresponding tab.

### 15.7.4 How to Request the Data Sheet

You can access data sheet related information via the LXI web browser, see "[Data Sheet](#)" on page 399.

## 15.8 Collecting Information for Technical Support

If you encounter problems that you cannot solve yourself, contact your Rohde & Schwarz support center as listed at <http://www.customersupport.rohde-schwarz.com>. Our support center staff is optimally trained to assist you in solving problems.

The support center finds solutions more quickly and efficiently if you provide them with information on the instrument and an error description.

- The following dialog boxes in the "Setup > Instrument Assembly" menu provide useful information:
  - **Hardware Configuration:** hardware assemblies
  - **Software and Options:** the status of all software and hardware options installed on your instrument
- **System Messages:** displayed in the "Info" line and provide information on any errors that have occurred
- **Support file:** a special file (\*.tar.gz file) with important support information that can be created automatically.  
The support \*.tar.gz file has a user definable name and contains the following files and information:
  - SgErrors.txt: chronological record of errors
  - SystemRestorationSMAB.savrc1.txt: instrument settings at the last correct shutdown of the instrument
  - UndoHistSuppInfo.xml: list of the last user interactions
  - DeviceFootprint\_<SerialNumber>\_<Date>\_<Time>.xml: service-related information on the instrument's configuration.
  - crashlog.txt, coredump: Postmortem debug info
  - Several files with information on the last performed adjustment and self-test.

See also the description of error messages [Chapter 15.1, "Error Messages"](#), on page 724.

#### To collect error information in a support file

1. Connect a USB device to the R&S SMA100B.
2. Select "System Config > Setup > Maintenance > Create R&S Support Information".

- In the "Create R&S Support Information" dialog, navigate to the `/usb` directory. Enter the support filename, for example `RSSupport_DeviceInfo`.

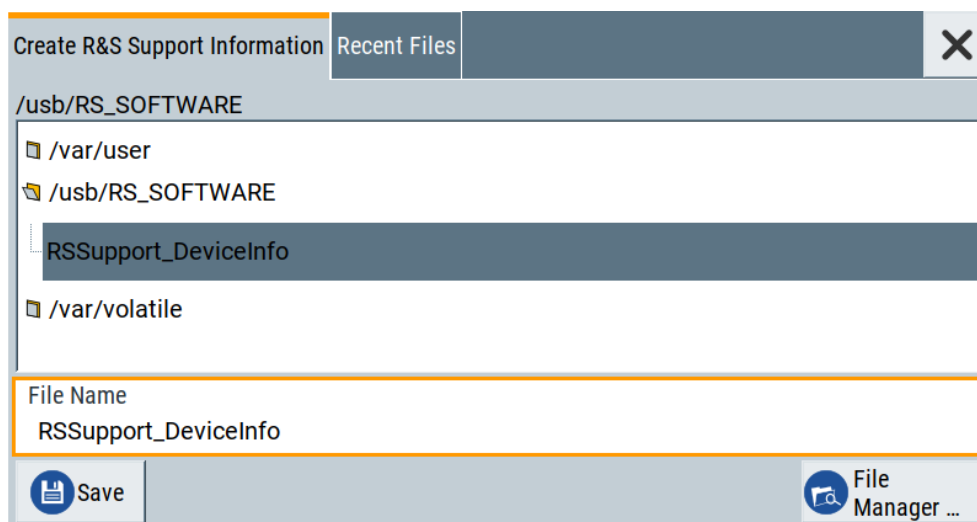

The error information and further required data is collected automatically. The support file `RSSupport_DeviceInfo.tar.gz` is created and stored in the `/usb` directory.

Collect the error information and attach it to an email in which you describe the problem. Send the email to the customer support address for your region as listed on the Internet (<http://www.customersupport.rohde-schwarz.com>).

#### To remove sensitive data

- For information on how to handle or remove the sensitive data from your instrument, refer to the description "Resolving Security Issues when working with R&S SMA100B".

#### Packing and transporting the instrument

- If the instrument has to be transported or shipped, see [Chapter 16, "Transporting"](#), on page 738.

## 15.9 Contacting Customer Support

### Technical support – where and when you need it

For quick, expert help with any Rohde & Schwarz product, contact our customer support center. A team of highly qualified engineers provides support and works with you to find a solution to your query on any aspect of the operation, programming or applications of Rohde & Schwarz products.

**Contact information**

Contact our customer support center at [www.rohde-schwarz.com/support](http://www.rohde-schwarz.com/support), or follow this QR code:



*Figure 15-1: QR code to the Rohde & Schwarz support page*

# 16 Transporting

## Lifting and carrying

See:

- ["Lifting and carrying the product"](#) on page 23
- [Chapter 3.1.1, "Lifting and Carrying"](#), on page 27.

## Packing

Use the original packaging material. It consists of antistatic wrap for electrostatic protection and packing material designed for the product.

If you do not have the original packaging, use similar materials that provide the same level of protection.

## Securing

When moving the R&S SMA100B in a vehicle or using transporting equipment, make sure that the R&S SMA100B is properly secured. Only use items intended for securing objects.

## Transport altitude

Unless otherwise specified in the data sheet, the maximum transport altitude without pressure compensation is 4500 m above sea level.

# 17 Maintenance, Storage and Disposal

The product does not require regular maintenance. It only requires occasional cleaning. It is however advisable to check the nominal data from time to time.

## 17.1 Cleaning

How to clean the product is described in "[Cleaning the product](#)" on page 25.

Do not use any liquids for cleaning. Cleaning agents, solvents (thinners, acetone), acids and bases can damage the front panel labeling, plastic parts and display.

## 17.2 Storage

Protect the product against dust. Ensure that the environmental conditions, e.g. temperature range and climatic load, meet the values specified in the data sheet.

## 17.3 Performing Maintenance Tasks

The R&S SMA100B is accurate due to integrated adjustment procedures. Internal adjustments are integrated self-calibration routines, which you can execute directly on the instrument.

Self-calibration routines that require additional equipment are performed at an authorized Rohde & Schwarz service center. For description, see R&S SMA100B service manual.

### When to start internal adjustments?

We recommend that you perform internal adjustments in the following cases:

- Before starting any application, that requires a maximum of level accuracy
- When a long period of time has passed since the last adjustments
- If the ambient temperature of the instrument significantly differs from the one of the last adjustments.

How to: See [Chapter 17.3.3.2, "How to Use the Internal Adjustments"](#), on page 746.

### 17.3.1 Date and Time

The R&S SMA100B uses an internal real-time clock to determine the date and time. It adjusts the time and date to the timezone of your location automatically, by providing a selection list of continents and cities.

The instrument records the time whenever you create or modify files on your instrument or you use timed licenses. By default, the instrument is set to the UTC timezone, but you can select the timezone according to your location.

Moreover, the instrument supports NTP protocol for synchronizing all connected instruments and computer systems to minimize time delays in the network.

### 17.3.1.1 Data and Time Settings

Access:

- ▶ Select "System Config > Setup > Maintenance > Date / Time".

The "Date / Time" dialog contains the time and data settings of the operating system.

This function is password-protected. Unlock the protection level 1 to access it.

The required remote commands are described in [Chapter 14.17, "SYSTEM Subsystem"](#), on page 690.

#### Settings:

<a href="#">Date</a> .....	740
<a href="#">Time</a> .....	740
<a href="#">Timezone</a> .....	741
<a href="#">NTP Address</a> .....	741
<a href="#">Use Time from NTP Server</a> .....	741

#### Date

Displays the date set in the operating system in the format [dd.mm.yyyy].

Remote command:

:[SYSTem:DATE](#) on page 710

#### Time

Displays the time set in the operating system in the format [hh.mm.ss].

The time setting corresponds to the selected [Use Time from NTP Server](#).



Remote command:

:SYSTem:TIME on page 711

### Timezone

Selects the timezone.

You can select the timezone according to the major cities on the respective continents.

**Note:** By typing the first letter, you can quickly navigate through the lists to find the desired destination.

Remote command:

:SYSTem:TIME:ZONE on page 712

:SYSTem:TIME:ZONE:CATalog? on page 712

### NTP Address

Sets the IP address or host name of the NTP server.

NTP is a network time protocol used for synchronizing all participating devices in a data network.

You can select a high-precision time server to reduce the impact of varying network delays.

Remote command:

:SYSTem:NTP:HOSTname on page 711

### Use Time from NTP Server

Activates clock synchronization of the network via the NTP protocol.

Remote command:

:SYSTem:NTP:STATe on page 711

## 17.3.1.2 How To Set Data and Time

### To select the timezone

1. Press the [Setup] key.
2. Select "Maintenance > Date /Time > Timezone".
3. Select continent and city of your location.  
**Tip:** By typing the first letter, you can quickly navigate through the lists to find the desired destination.
4. Close the dialogs.

The instrument adjusts the time according to the selected location.

### To set the date and time

1. Press the [Setup] key.
2. Select "Security > Protection".
3. Enable the "Protection Level 1".

The default password is 123456.

4. Select "Setup > Maintenance > Date / Time".
5. Adjust the settings.
6. Close the dialogs.

The instrument adopts the new date and time.

## 17.3.2 Check Front Panel

Within this dialog, you can verify the functionality of the control keys.

How To: See [Chapter 17.3.2.2, "How to Test the Front Panel"](#), on page 742

### 17.3.2.1 Check Front Panel Settings

Access:

- ▶ Select "System Config > Setup > Maintenance > Check Front Panel".



Reflecting the front panel, the "Check Front Panel" dialog contains all functions to test the operating elements of the instrument.

### 17.3.2.2 How to Test the Front Panel

See:

- ["Testing the key panel"](#) on page 743

- "Testing the touchscreen" on page 743
- "Terminating the test" on page 744
- "Debugging" on page 744

### Testing the key panel

To perform the key panel test, you operate the keys at the front panel, and check the response of the instrument in the "Check Front Panel" dialog. To perform this test properly, check each key of the front panel. The test is only completed, when you have verified all keys.

During the test, the actual functions of the keys are disabled.

1. Press the [Setup] key.
2. Select "Maintenance > Check Front Panel"  
The "Check Front Panel" dialog opens.
3. Press a key on the front panel.  
Check if the corresponding key in the "Check Front Panel" dialog turns green.
4. Press the same key a second time.  
Check that the key in the dialog turns red.  
**Note:** Pressing the same key again has no further effect, except for the [Esc] key. Pressing this key a third time, terminates the test procedure.
5. Continue with the next key on the front panel and repeat [step 3](#) to [step 5](#) until all keys are tested.

The test is completed, when each key is verified successfully, confirmed by a "Test passed" message.

### Testing the touchscreen

1. Press the [Setup] key.
2. Select "Maintenance > Check Touch Panel"  
The "Finger Paint" test window opens.

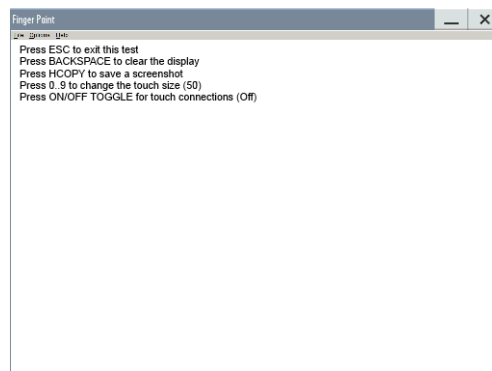

3. Drag with your finger one or more lines, for example diagonally across the screen.

The test traces the movements of your finger on the screen.

The following results are expected:

- If the lines are uninterrupted, the touchscreen works properly.

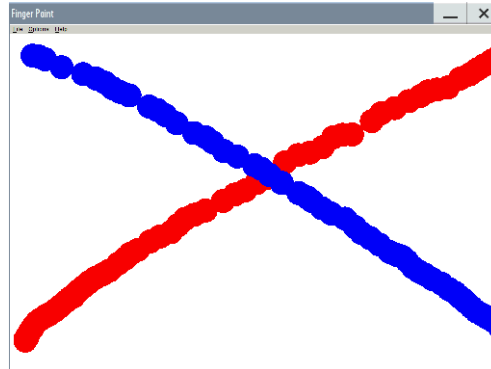

- If there are any gaps, the touch-sensitive functionality is damaged.

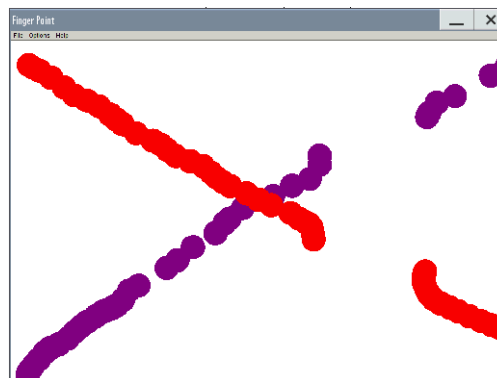

- To return to the "Check Front Panel" dialog, press [Esc].

#### Terminating the test

- ▶ Press the [Esc] key.

Exits the "Check Front Panel" dialog.

#### Debugging

1. If you detect a malfunction, for example, you press the front panel key the first time, and the color of the button in the dialog turns red (instead of green), the front panel key may be stuck.
2. Contact the Rohde & Schwarz customer support, see [Chapter 15.8, "Collecting Information for Technical Support"](#), on page 735.

### 17.3.3 Internal Adjustments

Internal adjustments are integrated adjustment procedures, which you can execute directly on the instrument.

### 17.3.3.1 Internal Adjustments Settings

Access:

- ▶ Select "System Config > Setup > General > Internal Adjustments".

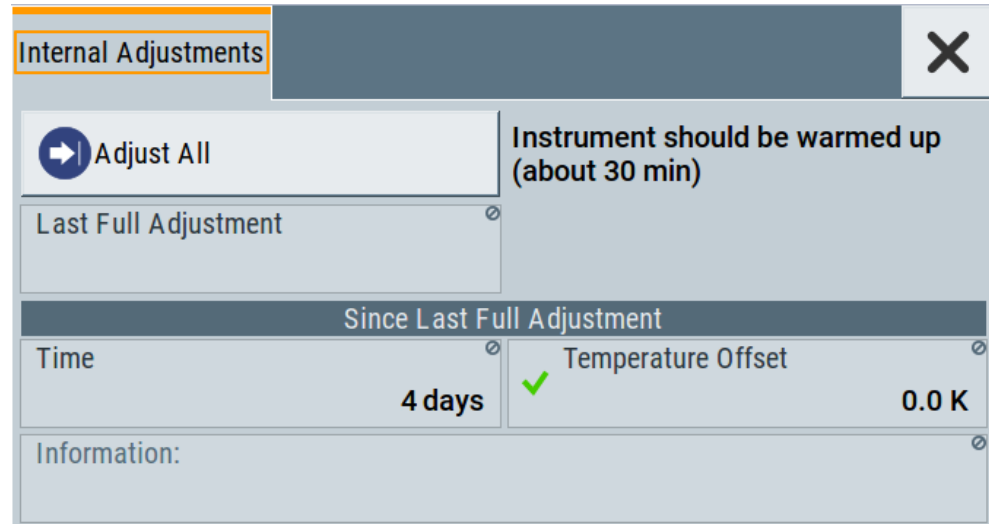

In this dialog, you can perform internal calibration routines and get information on the last performed calibration.

The "Temperature Offset" indicates the deviation of the current temperature of the instrument, compared to the temperature of the last adjustment.

The remote commands required to define these settings are described in [Chapter 14.6, "CALibration Subsystem"](#), on page 452.

How to: See [Chapter 17.3.3.2, "How to Use the Internal Adjustments"](#), on page 746.

#### Adjust All

Performs all available internal calibration routines of the instrument.

How to: See [Chapter 17.3.3.2, "How to Use the Internal Adjustments"](#), on page 746.

Remote command:

`:CALibration:ALL[:MEASure]?` on page 452

#### Last Full Adjustment

Displays the date of the last fully performed adjustment.

Remote command:

`:CALibration<hw>:ALL:DATE?` on page 452

#### Time

Displays the elapsed time since the last full adjustment.

Remote command:

`:CALibration<hw>:ALL:TIME?` on page 453

**Temperature Offset**

Displays the temperature difference, comparing the temperature of the last adjustment to the current instrument temperature.

A green checkmark indicates that the offset is within the permitted range. If the temperature deviates more than  $\pm 5$  K, the instrument indicates a warning icon.

Remote command:

`:CALibration<hw>:ALL:TEMP?` on page 453

**Information**

Displays information to the current adjustment state.

Remote command:

`:CALibration<hw>:ALL:INformation?` on page 453

**Continue Adjustment on Error**

Continues the calibration even though an error was detected. By default adjustments are aborted on error.

This function is password-protected. Unlock the protection level 1 to access it.

Remote command:

`:CALibration<hw>:CONTinueonerror` on page 454

### 17.3.3.2 How to Use the Internal Adjustments

**Deciding whether to run internal adjustments**

1. Select "System Config > Setup > Internal Adjustment".
2. Observe the status and color indication in the section "Since Last Full Adjustment".  
Green: Internal adjustments are not required.  
Red: Internal adjustments are required. Observe also the indication in the "Information" field.
3. We recommend that you run internal adjustments in the following cases:
  - Before starting any application, that requires a maximum of level accuracy
  - When a long period of time has passed since the last adjustments
  - If the ambient temperature of the instrument significantly differs from the one of the last adjustments.
4. Proceed as described in "[Running internal adjustments](#)" on page 746.

**Running internal adjustments**

1. **NOTICE!** Adjustments can be invalid if performed when the instrument is not warmed-up.

Wait until the instrument has reached its operating temperature before you start the adjustment procedure.

The warm-up time is up to 30 minutes.

2. **NOTICE!** High power at the RF output applied during internal adjustment can destroy a connected DUT (device under test).  
Disconnect the DUT.
3. Replace the DUT by a terminating resistor with adequate power rating.  
The required power of the resistor varies depending on whether the instrument is equipped with a high-power option.
4. Select "System Config > Setup > Internal Adjustment > Adjust All".  
A warning message prompts you to make sure that you have terminated the RF output.

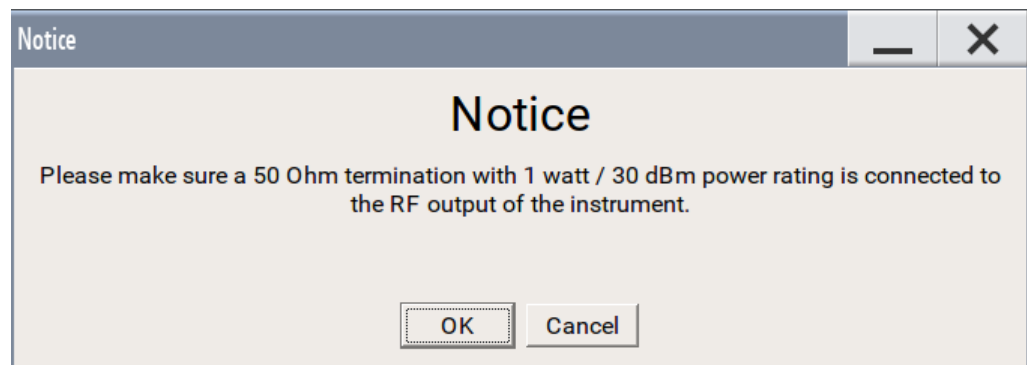

5. Confirm with "Ok".  
If the termination resistor is missing, a second warning message appears.

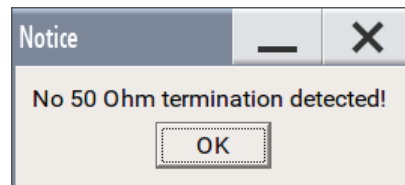

The adjustment process starts.

6. Do not interrupt the adjustment process.  
The extent of the adjustments depends on the installed options.  
A progress indicator shows the status of the adjustment process.  
If any error occurs, the process aborts and an error message appears in the "Info" line.  
If there is an error:
  - Select "Info".  
Observe the error message.
  - Continue the process.  
See "[Continuing the adjustment process if error appears](#)" on page 747.

#### Continuing the adjustment process if error appears

Per default, if any error occurs during the adjustment process, the process aborts. An error message appears in the "Info" line.

If you prefer to finish the adjustments also if there is an error, proceed as follows:

1. Select "System Config > Setup > Security > Protection" and unlock the protection level 1.  
See "[Protection Level/Password](#)" on page 355.
2. Select "System Config > Setup > Internal Adjustment > Configuration > Continue Adjustment on Error > On".
3. Proceed as described in "[Running internal adjustments](#)" on page 746.

### 17.3.4 FPGA/μC Update Settings

Access:

- ▶ Select "System Config > Setup > Maintenance > FPGA/μC Update".

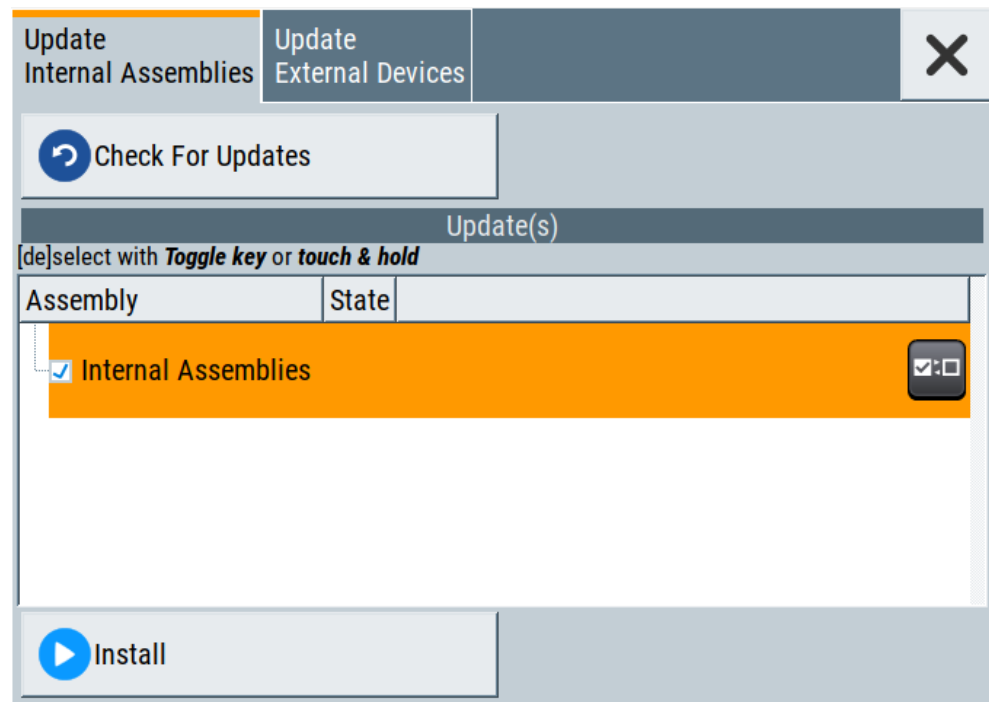

This dialog enables you to check for internal assembly updates and perform updates.

#### Settings:

<a href="#">Check For Updates</a> .....	749
<a href="#">Assembly</a> .....	749
<a href="#">Install</a> .....	749
<a href="#">Shut down</a> .....	749
<a href="#">Update External Devices</a> .....	749
L <a href="#">Check For Updates</a> .....	749



**Check For Updates**

Check for updates of the FPGA/μC.

Remote command:

n.a.

**Assembly**

The table shows the installed assemblies and their states.

"Assembly"      Assembly designation.

"State"            Indicates the current state of installed assemblies.

**Install**

Install all available updates for the FPGA/μC.

Remote command:

n.a.

**Shut down**

For at least one assembly "State = Done" and no pending assemblies, shuts the instrument down to apply installed updates.

Remote command:

:SYSTem:SHUTdown on page 714

**Update External Devices**

This dialog shows the update options of external devices connected to the instrument.

**Check For Updates ← Update External Devices**

Check for updates of external devices.

Remote command:

n.a.

### 17.3.5 Exchanging the RF Adapter Port

It is important, that you take care that the RF connectors applied to the port are clean, mechanically compatible and not damaged. Although the 1.85 mm adapter is designed to withstand several hundred mating cycles, it can reach the end of life or be damaged. Therefore, the adapter port is exchangeable, which you can replace. Refer to the R&S SMA100B Service Manual for the corresponding instructions.

## 17.4 Disposal

Rohde & Schwarz is committed to making careful, ecologically sound use of natural resources and minimizing the environmental footprint of our products. Help us by disposing of waste in a way that causes minimum environmental impact.

### Electrical and electronic equipment

A product that is labeled as follows cannot be disposed of in normal household waste after it has come to the end of its service life. Even disposal via the municipal collection points for waste electrical and electronic equipment is not permitted.



*Figure 17-1: Labeling in line with EN 50419*

Rohde & Schwarz has developed a disposal concept for the eco-friendly disposal or recycling of waste material. As a manufacturer, Rohde & Schwarz completely fulfills its obligation to take back and dispose of electrical and electronic waste. Contact your local service representative to dispose of the product.

# Annex

## A Reference Information for Remote Control

### A.1 Additional Basics on Remote Control

This section provides basic information using the remote control.

#### A.1.1 Messages

The messages transferred on the data lines are divided into the following categories:

- **Interface messages**  
Interface messages are transmitted to the instrument on the data lines, with the attention line being active (LOW). They are used to communicate between the controller and the instrument. Interface messages can only be sent by instruments that have GPIB bus functionality. For details see the sections for the required interface.
- **Instrument messages**  
Instrument messages are employed in the same way for all interfaces, if not indicated otherwise in the description. Structure and syntax of the instrument messages are described in [Chapter A.1.3, "SCPI Command Structure"](#), on page 752. A detailed description of all messages available for the instrument is provided in the chapter "Remote Control Commands".  
There are different types of instrument messages, depending on the direction they are sent:
  - Commands
  - Instrument responses

#### Commands

Commands (program messages) are messages the controller sends to the instrument. They operate the instrument functions and request information. The commands are subdivided according to two criteria:

- According to the effect they have on the instrument:
  - **Setting commands** cause instrument settings such as a reset of the instrument or setting the frequency.
  - **Queries** cause data to be provided for remote control, e.g. for identification of the instrument or polling a parameter value. Queries are formed by directly appending a question mark to the command header.
- According to their definition in standards:
  - **Common commands:** their function and syntax are precisely defined in standard IEEE 488.2. They are employed identically on all instruments (if implemented). They refer to functions such as management of the standardized status registers, reset and self-test.

- **Instrument control commands** refer to functions depending on the features of the instrument such as frequency settings. Many of these commands have also been standardized by the SCPI committee. These commands are marked as "SCPI confirmed" in the command reference chapters. Commands without this SCPI label are device-specific; however, their syntax follows SCPI rules as permitted by the standard.

### Instrument responses

Instrument responses (response messages and service requests) are messages the instrument sends to the controller after a query. They can contain measurement results, instrument settings and information on the instrument status.

## A.1.2 LAN Interface Messages

In the LAN connection, the interface messages are called low-level control messages. These messages can be used to emulate interface messages of the GPIB bus.

Command	Long term	Effect on the instrument
&ABO	Abort	Aborts processing of the commands just received.
&DCL	Device Clear	Aborts processing of the commands just received and sets the command processing software to a defined initial state. Does not change the instrument setting.
&GTL	Go to Local	Transition to the "local" state (manual control). (The instrument automatically returns to remote state when a remote command is sent UNLESS &NREN was sent before.)
&GTR	Go to Remote	Enables automatic transition from local state to remote state by a subsequent remote command (after &NREN was sent).
&GET	Group Execute Trigger	Triggers a previously active instrument function (e.g. a sweep). The effect of the command is the same as with that of a pulse at the external trigger signal input.
&LLO	Local Lockout	Disables transition from remote control to manual control by means of the front panel keys.
&NREN	Not Remote Enable	Disables automatic transition from local state to remote state by a subsequent remote command. (To re-activate automatic transition use &GTR.)
&POL	Serial Poll	Starts a serial poll.

## A.1.3 SCPI Command Structure

SCPI commands consist of a header and, in most cases, one or more parameters. The header and the parameters are separated by a "white space" (ASCII code 0 to 9, 11 to 32 decimal, e.g. blank). The headers may consist of several mnemonics (keywords). Queries are formed by appending a question mark directly to the header.

The commands can be either device-specific or device-independent (common commands). Common and device-specific commands differ in their syntax.

### A.1.3.1 Syntax for Common Commands

Common (= device-independent) commands consist of a header preceded by an asterisk (\*), and possibly one or more parameters.

*Table A-1: Examples of common commands*

*RST	RESET	Resets the instrument.
*ESE	EVENT STATUS ENABLE	Sets the bits of the event status enable registers.
*ESR?	EVENT STATUS QUERY	Queries the contents of the event status register.
*IDN?	IDENTIFICATION QUERY	Queries the instrument identification string.

### A.1.3.2 Syntax for Device-Specific Commands



Not all commands used in the following examples are necessarily implemented in the instrument. For demonstration purposes only, assume the existence of the following commands for this section:

- DISPLAY[:WINDow<1...4>]:MAXimize <Boolean>
  - FORMAT:READings:DATA <type>[,<length>]
  - HCOpy:DEvice:COLor <Boolean>
  - HCOpy:DEvice:CMAP:COLor:RGB <red>,<green>,<blue>
  - HCOpy[:IMMediate]
  - HCOpy:ITEM:ALL
  - HCOpy:ITEM:LABel <string>
  - HCOpy:PAGE:DIMensions:QUADrant [<N>]
  - HCOpy:PAGE:ORientation LANDscape | PORTrait
  - HCOpy:PAGE:SCALE <numeric value>
  - MMEMemory:COpy <file\_source>,<file\_destination>
  - SENSE:BANDwidth|BWIDth[:RESolution] <numeric\_value>
  - SENSE:FREQuency:STOP <numeric value>
  - SENSE:LIST:FREQuency <numeric\_value>{,<numeric\_value>}
- 
- [Long and short form](#)..... 753
  - [Numeric Suffixes](#)..... 754
  - [Optional Mnemonics](#)..... 754

#### Long and short form

The mnemonics feature a long form and a short form. The short form is marked by upper case letters, the long form corresponds to the complete word. Either the short form or the long form can be entered; other abbreviations are not permitted.

**Example:**

HCOPY:DEVice:COLor ON is equivalent to HCOP:DEV:COL ON.

**Case-insensitivity**

Upper case and lower case notation only serves to distinguish the two forms in the manual, the instrument itself is case-insensitive.

**Numeric Suffixes**

If a command can be applied to multiple instances of an object, e.g. specific channels or sources, the required instances can be specified by a suffix added to the command. Numeric suffixes are indicated by angular brackets (<1...4>, <n>, <i>) and are replaced by a single value in the command. Entries without a suffix are interpreted as having the suffix 1.

**Example:**

Definition: HCOpy:PAGE:DIMensions:QUADrant [<N>]

Command: HCOP:PAGE:DIM:QUAD2

This command refers to the quadrant 2.

**Different numbering in remote control**

For remote control, the suffix may differ from the number of the corresponding selection used in manual operation. SCPI prescribes that suffix counting starts with 1. Suffix 1 is the default state and used when no specific suffix is specified.

Some standards define a fixed numbering, starting with 0. If the numbering differs in manual operation and remote control, it is indicated for the corresponding command.

**Optional Mnemonics**

Some command systems permit certain mnemonics to be inserted into the header or omitted. These mnemonics are marked by square brackets in the description. The instrument must recognize the long command to comply with the SCPI standard. Some commands are considerably shortened by these optional mnemonics.

**Example:**

Definition: HCOpy[:IMMediate]

Command: HCOP:IMM is equivalent to HCOP



### Optional mnemonics with numeric suffixes

Do not omit an optional mnemonic if it includes a numeric suffix that is relevant for the effect of the command.

#### Example:

Definition: `DISPlay[:WINDow<1...4>]:MAXimize <Boolean>`

Command: `DISP:MAX ON` refers to window 1.

In order to refer to a window other than 1, you must include the optional `WINDow` parameter with the suffix for the required window.

`DISP:WIND2:MAX ON` refers to window 2.

### A.1.3.3 SCPI Parameters

Many commands are supplemented by a parameter or a list of parameters. The parameters must be separated from the header by a "white space" (ASCII code 0 to 9, 11 to 32 decimal, e.g. blank).

The parameters required for each command and the allowed range of values are specified in the command description.

Allowed parameters are:

• <a href="#">Numeric Values</a> .....	755
• <a href="#">Special Numeric Values</a> .....	756
• <a href="#">Boolean Parameters</a> .....	756
• <a href="#">Text Parameters</a> .....	757
• <a href="#">Character Strings</a> .....	757
• <a href="#">Block Data</a> .....	757

#### Numeric Values

Numeric values can be entered in any form, i.e. with sign, decimal point and exponent. Values exceeding the resolution of the instrument are rounded up or down. The mantissa may comprise up to 255 characters, the exponent must lie inside the value range -32000 to 32000. The exponent is introduced by an "E" or "e". Entry of the exponent alone is not allowed.

#### Example:

`SENS:FREQ:STOP 1500000 = SENS:FREQ:STOP 1.5E6`

#### Units

For physical quantities, the unit can be entered. If the unit is missing, the basic unit is used. Allowed unit prefixes are:

- G (giga)
- MA (mega), MOHM, MHZ
- K (kilo)
- M (milli)
- U (micro)

- N (nano)

**Example:**

```
SENSe:FREQ:STOP 1.5GHz = SENSe:FREQ:STOP 1.5E9
```

Some settings allow relative values to be stated in percent. According to SCPI, this unit is represented by the `PCT` string.

**Example:**

```
HCOP:PAGE:SCAL 90PCT
```

**Special Numeric Values**

The following mnemonics are special numeric values. In the response to a query, the numeric value is provided.

- **MIN and MAX:** denote the minimum and maximum value.
- **DEF:** denotes a preset value which has been stored in the EPROM. This value conforms to the default setting, as it is called by the `*RST` command.
- **UP and DOWN:** increases or reduces the numeric value by one step. The step width can be specified via an allocated step command for each parameter which can be set via `UP` and `DOWN`.
- **INF and NINF:** INfinity and negative INfinity (NINF) represent the numeric values  $9.9E37$  or  $-9.9E37$ , respectively. `INF` and `NINF` are only sent as instrument responses.
- **NAN:** Not A Number (NAN) represents the value  $9.91E37$ . `NAN` is only sent as a instrument response. This value is not defined. Possible causes are the division of zero by zero, the subtraction of infinite from infinite and the representation of missing values.

**Example:**

Setting command: `SENSe:LIST:FREQ MAXimum`

Query: `SENS:LIST:FREQ?`

Response: `3.5E9`

**Queries for special numeric values**

The numeric values associated to `MAXimum`/`MINimum`/`DEFault` can be queried by adding the corresponding mnemonic after the quotation mark.

Example: `SENSe:LIST:FREQ? MAXimum`

Returns the maximum numeric value as a result.

**Boolean Parameters**

Boolean parameters represent two states. The "ON" state (logically true) is represented by "ON" or a numeric value 1. The "OFF" state (logically untrue) is represented by "OFF" or the numeric value 0. The numeric values are provided as the response for a query.



**Example:**

Setting command: `HCOPY:DEV:COL ON`

Query: `HCOPY:DEV:COL?`

Response: 1

**Text Parameters**

Text parameters observe the syntactic rules for mnemonics, i.e. they can be entered using a short or long form. Like any parameter, they have to be separated from the header by a white space. In the response to a query, the short form of the text is provided.

**Example:**

Setting command: `HCOPY:PAGE:ORIENTATION LANDscape`

Query: `HCOPY:PAGE:ORI?`

Response: LAND

**Character Strings**

Strings must always be entered in quotation marks (' or ").

**Example:**

`HCOPY:ITEM:LABEL "Test1"`

`HCOPY:ITEM:LABEL 'Test1'`

**Block Data**

Block data is a format which is suitable for the transmission of large amounts of data. For example, a command using a block data parameter has the following structure:

```
FORMat:READings:DATA #45168xxxxxxxx
```

The ASCII character # introduces the data block. The next number indicates how many of the following digits describe the length of the data block. In the example the 4 following digits indicate the length to be 5168 bytes. The data bytes follow. During the transmission of these data bytes all end or other control signs are ignored until all bytes are transmitted.

#0 specifies a data block of indefinite length. The use of the indefinite format requires a `NL^END` message to terminate the data block. This format is useful when the length of the transmission is not known or if speed or other considerations prevent segmentation of the data into blocks of definite length.

**A.1.3.4 Overview of Syntax Elements**

The following tables provide an overview of the syntax elements and special characters.

**Table A-2: Syntax elements**

:	The colon separates the mnemonics of a command.
;	The semicolon separates two commands of a command line. It does not alter the path.
,	The comma separates several parameters of a command.
?	The question mark forms a query.
*	The asterisk marks a common command.
' '	Quotation marks introduce a string and terminate it (both single and double quotation marks are possible).
#	The hash symbol introduces binary, octal, hexadecimal and block data. <ul style="list-style-type: none"> <li>• Binary: #B10110</li> <li>• Octal: #O7612</li> <li>• Hexa: #HF3A7</li> <li>• Block: #21312</li> </ul>
	A "white space" (ASCII-Code 0 to 9, 11 to 32 decimal, e.g. blank) separates the header from the parameters.

**Table A-3: Special characters**

	<p><b>Parameters</b></p> <p>A vertical stroke in parameter definitions indicates alternative possibilities in the sense of "or". The effect of the command differs, depending on which parameter is used.</p> <p>Example:</p> <p>Definition:HCOPY:PAGE:ORIENTATION LANDscape   PORTRait</p> <p>Command HCOP:PAGE:ORI LAND specifies landscape orientation</p> <p>Command HCOP:PAGE:ORI PORT specifies portrait orientation</p> <p><b>Mnemonics</b></p> <p>A selection of mnemonics with an identical effect exists for several commands. These mnemonics are indicated in the same line; they are separated by a vertical stroke. Only one of these mnemonics needs to be included in the header of the command. The effect of the command is independent of which of the mnemonics is used.</p> <p>Example:</p> <p>DefinitionSENSE:BANDwidth BWIDth[:RESolution] &lt;numeric_value&gt;</p> <p>The two following commands with identical meaning can be created:</p> <p>SENS:BAND:RES 1</p> <p>SENS:BWID:RES 1</p>
[ ]	<p>Mnemonics in square brackets are optional and may be inserted into the header or omitted.</p> <p>Example: HCOPY[:IMMEDIATE]</p> <p>HCOP: IMM is equivalent to HCOP</p>
{ }	<p>Parameters in curly brackets are optional and can be inserted once or several times, or omitted.</p> <p>Example: SENSE:LIST:FREQUENCY &lt;numeric_value&gt;{,&lt;numeric_value&gt;}</p> <p>The following are valid commands:</p> <p>SENS:LIST:FREQ 10</p> <p>SENS:LIST:FREQ 10,20</p> <p>SENS:LIST:FREQ 10,20,30,40</p>

### A.1.3.5 Structure of a Command Line

A command line may consist of one or several commands. It is terminated by one of the following:

- <New Line>
- <New Line> with EOI
- EOI together with the last data byte

Several commands in a command line must be separated by a semicolon ";".

#### Example:

```
MMEM:COPY "Test1", "MeasurementXY";:HCOP:ITEM ALL
```

This command line contains two commands. The first command belongs to the MMEM system, the second command belongs to the HCOP system. If the next command belongs to a different command system, the semicolon is followed by a colon.

#### Example:

```
HCOP:ITEM ALL;:HCOP:IMM
```

This command line contains two commands. Both commands are part of the HCOP command system, i.e. they have one level in common.

If the successive commands belong to the same system, having one or several levels in common, the command line can be abbreviated. When abbreviating the command line, the second command begins with the level below HCOP. The colon after the semicolon is omitted. The abbreviated form of the command line reads as follows:

```
HCOP:ITEM ALL;IMM
```

#### Example:

```
HCOP:ITEM ALL
```

```
HCOP:IMM
```

A new command line always begins with the complete path.

### A.1.3.6 Responses to Queries

A query is defined for each setting command unless explicitly specified otherwise. It is formed by adding a question mark to the associated setting command. According to SCPI, the responses to queries are partly subject to stricter rules than in standard IEEE 488.2.

- The requested parameter is transmitted without a header.  
**Example:** `HCOP:PAGE:ORI?`, **Response:** `LAND`
- Maximum values, minimum values and all other quantities that are requested via a special text parameter are returned as numeric values.  
**Example:** `SENSe:FREQuency:STOP? MAX`, **Response:** `3.5E9`
- Numeric values are output without a unit. Physical quantities are referred to the basic units or to the units set using the `Unit` command. The response `3.5E9` in the previous example stands for 3.5 GHz.

- Truth values (Boolean values) are returned as 0 (for OFF) and 1 (for ON).

**Example:**

Setting command: `HCOPY:DEV:COL ON`

Query: `HCOPY:DEV:COL?`

Response: 1

- Text (character data) is returned in a short form.

**Example:**

Setting command: `HCOPY:PAGE:ORIENTATION LANDscape`

Query: `HCOPY:PAGE:ORI?`

Response: LAND

- Invalid numerical results  
In some cases, particularly when a result consists of multiple numeric values, invalid values are returned as 9.91E37 (not a number).

## A.1.4 Command Sequence and Synchronization

IEEE 488.2 defines a distinction between overlapped and sequential commands:

- A sequential command always completes executing before the next command starts. Commands that are processed quickly are defined as sequential commands. They are not implemented in the instrument. However, the execution time of most of the commands is so short that they act as sequential commands, if they are sent in separate command lines.
- An overlapping command is still running when the next command starts. Usually, an overlapping command takes a certain time to process its task, and thus allows the program to execute other tasks, while it is still running. If overlapping commands have to follow a specific order, for example to avoid incorrect measurement readings, they must be executed in sequence. This is called synchronization between the controller and the instrument.

Several setting commands within a command line are not necessarily processed in the order they are received. Even if they are implemented as sequential commands. To follow a particular sequence, send each command in a separate line.



As a rule, send commands and queries in different program messages.

### A.1.4.1 Preventing Overlapping Execution

To prevent an overlapping execution of commands, one of the commands `*OPC`, `*OPC?` or `*WAI` can be used. All three commands cause a certain action only to be carried out after the hardware has been set. The controller can be forced to wait for the corresponding action to occur.

Table A-4: Synchronization using \*OPC, \*OPC? and \*WAI

Command	Action	Programming the controller
*OPC	Sets the Operation Complete bit in the ESR after all previous commands have been executed.	<ul style="list-style-type: none"> <li>Setting bit 0 in the ESE</li> <li>Setting bit 5 in the SRE</li> <li>Waiting for service request (SRQ)</li> </ul>
*OPC?	Stops command processing until 1 is returned. This occurs when all pending operations are completed.	Send *OPC? directly after the command whose processing must be terminated before other commands can be executed.
*WAI	Stops further command processing until all commands sent before *WAI have been executed.	Send *WAI directly after the command whose processing must be terminated before other commands are executed.

Command synchronization using \*WAI or \*OPC? is a good choice if the overlapped command takes only little time to process. The two synchronization commands simply block overlapped execution of the command. Append the synchronization command to the overlapping command, for example:

```
SINGLE; *OPC?
```

For time consuming overlapped commands, you can allow the controller or the instrument to do other useful work while waiting for command execution. Use one of the following methods:

#### \*OPC with a service request

1. Set the OPC mask bit (bit no. 0) in the ESE: \*ESE 1
2. Set bit no. 5 in the SRE: \*SRE 32 to enable ESB service request.
3. Send the overlapped command with \*OPC .
4. Wait for a service request.

The service request indicates that the overlapped command has finished.

#### \*OPC? with a service request

1. Set bit no. 4 in the SRE: \*SRE 16 to enable MAV service request.
2. Send the overlapped command with \*OPC?.
3. Wait for a service request.

The service request indicates that the overlapped command has finished.

#### Event status register (ESE)

1. Set the OPC mask bit (bit no. 0) in the ESE: \*ESE 1
2. Send the overlapped command without \*OPC, \*OPC? or \*WAI.

3. Poll the operation complete state periodically (with a timer) using the sequence:  
\*OPC; \*ESR?

A return value (LSB) of 1 indicates that the overlapped command has finished.

#### A.1.4.2 Examples to Command Sequence and Synchronization

See the following examples to command sequences and synchronization. Some examples given illustrate possible constellations for overlapping tasks.

##### Example: Commands and queries in one message

The response to a query combined in a program message with commands that affect the queried value is not predictable.

The following commands always return the specified result:

```
:FREQ:STAR 1GHZ;SPAN 100 :FREQ:STAR?
```

Result:

```
1000000000 (1 GHz)
```

Whereas the result for the following commands is not specified by SCPI:

```
:FREQ:STAR 1GHZ;STAR?;SPAN 1000000
```

The result could be the value of `START` before the command was sent since the instrument might defer executing the individual commands until a program message terminator is received. The result could also be 1 GHz if the instrument executes commands as they are received.

##### Example: Overlapping command with \*OPC

The instrument implements `*RST` as an overlapped command. Assuming that `*RST` takes longer to execute than `*OPC`, sending the following command sequence results in initiating a reset and, after some time, setting the `OPC` bit in the `ESR`:

```
*RST; *OPC
```

Sending the following commands still initiates a reset:

```
*RST; *OPC; *CLS
```

However, since the operation is still pending when the instrument executes `*CLS`, forcing it into the "Operation Complete Command Idle" State (OCIS), `*OPC` is effectively skipped. The `OPC` bit is not set until the instrument executes another `*OPC` command.

##### Example: Overlapped command followed by non-conflicting commands

Suppose that the instrument is switched on to provide a real time test signal that requires some calculation time. At the same time, some settings for the configuration of a different signal are made which do not interact with the generated signal (for example the signal may be used later on). The signal generation and the signal configuration are independent from each other, so there is no need to synchronize the following overlapped commands:

```
SOUR:BB:3GPP:STAT ON
```

```
SOUR:BB:GSM:FORM FSK2
```

**Example: Overlapped command followed by conflicting commands**

Suppose that the generator is switched on to provide a real time test signal that requires some calculation time. This signal is to be added to a waveform from the second baseband generator. In this case, the application program has to make sure that the real signal is available in the added signal before further action is started. This involves an appropriate synchronization technique for the first command (the following sequence assumes an appropriate routing):

```
SOUR:BB:3GPP:STAT ON
```

The instrument waits until command has finished.

```
SOUR2:BB:GSM:STAT ON
```

Depending on the selected synchronization techniques, non-conflicting commands can be executed while waiting until the synchronized overlapped command has finished.

**Example: Polling the progress of the zeroing process**

Suppose that you start the zeroing for a connected power sensor via the remote control command `SENS1:ZERO`. This process blocks the processing of further tasks during execution. The query for completeness is performed with the `*OPC?` command. It returns a 1 in the output buffer when the process is completed.

```
SENS:ZERO;*OPC?
```

Instead of waiting via `*OPC?`, you can perform alternative tasks while the zeroing is running, as for example updating the GUI or adjusting other instruments. Synchronize the commands by querying the progress of the zeroing process periodically via the event status register `*ESR?`:

```
*SRE 32
```

Sets the service request enable. The bit is set when an event in the event status register occurs.

```
*ESE 1
```

Configures the mask of the event status register to "Operation Complete".

```
SENS:ZERO;*OPC
```

Sets the evaluation via the status byte query. It uses `*OPC?` as the reference.

```
*CLS
```

Clears all status registers.

Even if the instrument is busy, you can perform this procedure, since the query is executed in a subchannel.

## A.1.5 Status Reporting System

The status reporting system stores all information on the current operating state of the instrument, and on errors which have occurred. This information is stored in the status registers and in the error queue.

You can query both with the commands of the [STATus Subsystem](#).

### A.1.5.1 Hierarchy of the Status Registers

The [Figure A-1](#) shows the hierarchical structure of information in the status registers (ascending from left to right).

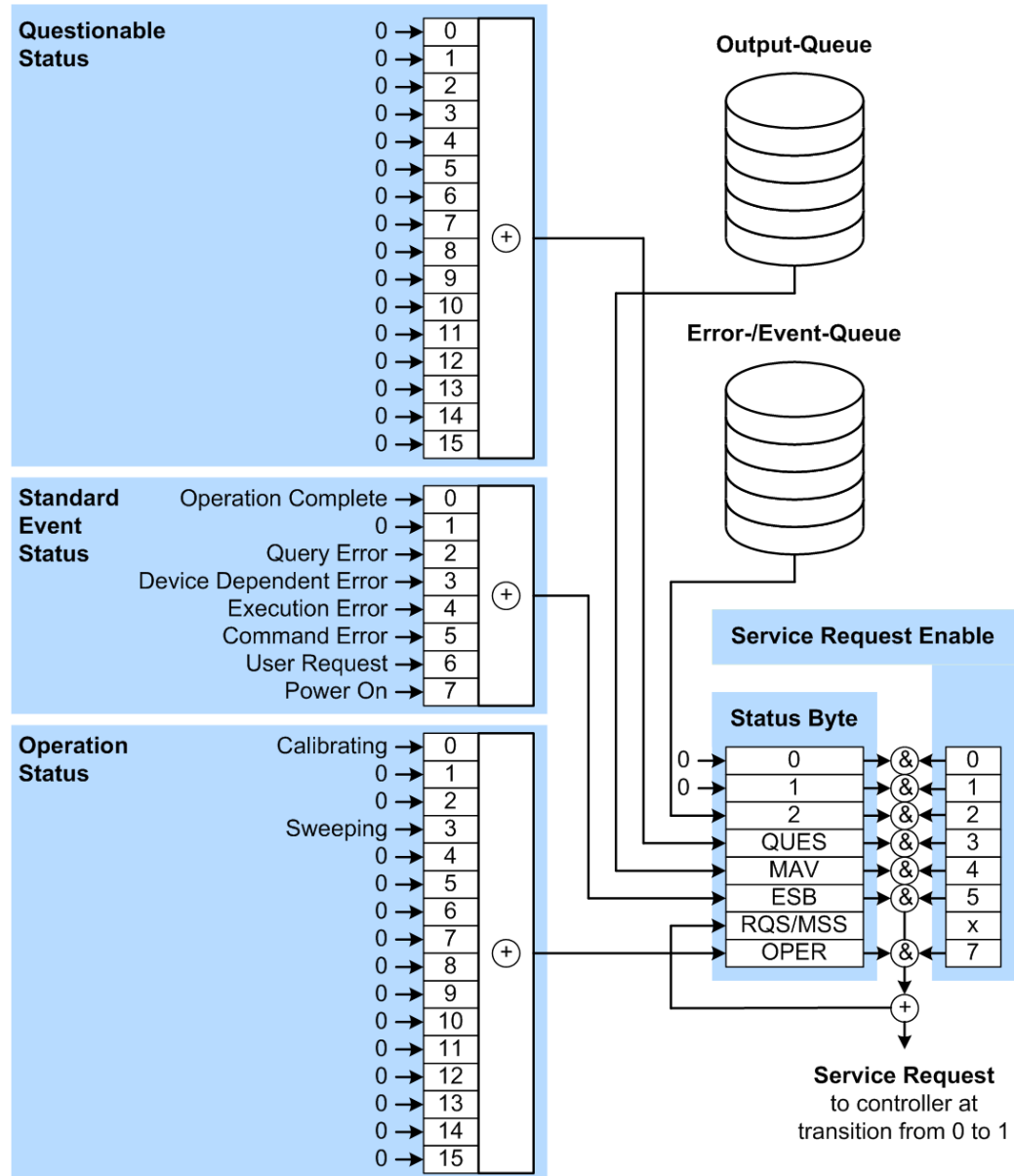

**Figure A-1:** Graphical overview of the status registers hierarchy

OPER = Operation Status Summary Bit  
 RQS/MSS = Service Request Generation  
 ESB = Standard Event Status Summary Bit  
 MAV = Message Available in Output Queue  
 QUES = Questionable Status Summary Bit  
 2 = Error- /Event-Queue  
 1, 0 = not used

**Note:** This legend explains the abbreviations to the Status Byte Register.



The R&S SMA100B uses the following status registers:

- **Status Byte (STB)** and **Service Request Enable (SRE)**, see [Chapter A.1.5.3, "Status Byte \(STB\) and Service Request Enable Register \(SRE\)"](#), on page 767.
- **Standard Event Status**, i.e. the Event status Register (ESR) and the Event Status Enable (ESE), see [Chapter A.1.5.4, "Event Status Register \(ESR\) and Event Status Enable Register \(ESE\)"](#), on page 768.
- **Questionable Status** and **Operation Status**, the (SCPI status registers, see [Chapter A.1.5.2, "Structure of a SCPI Status Register"](#), on page 765, [Chapter A.1.5.5, "Questionable Status Register \(STATus:QUESTionable\)"](#), on page 769 and [Chapter A.1.5.6, "Operation Status Register \(STATus:OPERation\)"](#), on page 769.
- **Output-Queue**  
The output queue contains the messages the instrument returns to the controller. It is not part of the status reporting system but determines the value of the `MAV` bit in the `STB` and thus is represented in the overview.
- **Error- /Event-Queue**  
The error-/event-queue contains all errors and events that have occurred in the past. When reading the queue, the instrument starts with the first occurred error/event.

All status registers have the same internal structure.



#### **SRE, ESE**

The service request enable register `SRE` can be used as `ENABLE` part of the `STB` if the `STB` is structured according to SCPI. By analogy, the `ESE` can be used as the `ENABLE` part of the `ESR`.

### **A.1.5.2 Structure of a SCPI Status Register**

Each standard SCPI register consists of 5 parts. Each part has a width of 16 bits and has different functions. The individual bits are independent of each other, i.e. each hardware status is assigned a bit number which is valid for all five parts. Bit 15 (the most significant bit) is set to zero for all parts. Thus the contents of the register parts can be processed by the controller as positive integers.

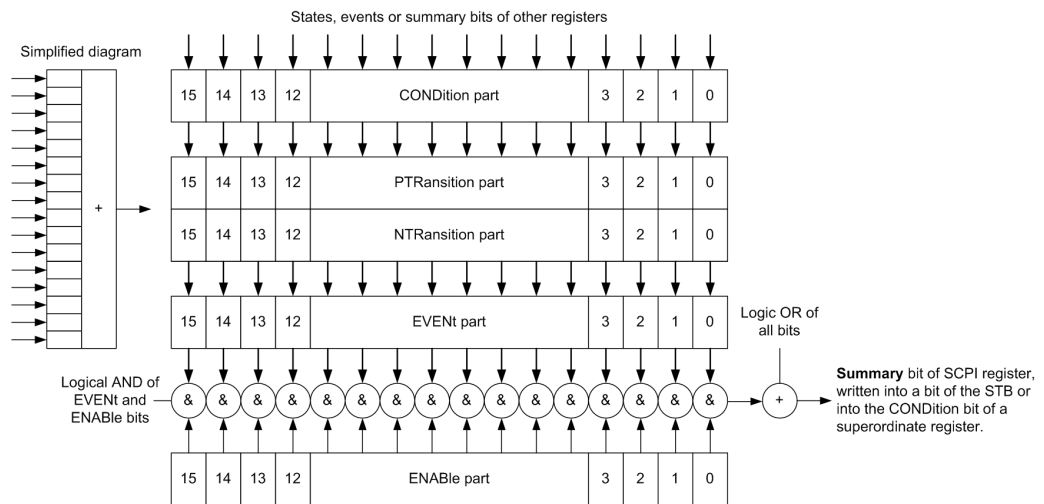

Figure A-2: The status-register model

### Description of the five status register parts

The five parts of a SCPI register have different properties and functions:

- **CONDition**

The **CONDition** part is written into directly by the hardware or the sum bit of the next lower register. Its contents reflect the current instrument status. This register part can only be read, but not written into or cleared. Its contents are not affected by reading.

- **PTRansition / NTRansition**

The two transition register parts define which state transition of the **CONDition** part (none, 0 to 1, 1 to 0 or both) is stored in the **EVENT** part.

The **Positive-TRansition** part acts as a transition filter. When a bit of the **CONDition** part is changed from 0 to 1, the associated **PTR** bit decides whether the **EVENT** bit is set to 1.

- **PTR** bit =1: the **EVENT** bit is set.
- **PTR** bit =0: the **EVENT** bit is not set.

This part can be written into and read as required. Its contents are not affected by reading.

The **Negative-TRansition** part also acts as a transition filter. When a bit of the **CONDition** part is changed from 1 to 0, the associated **NTR** bit decides whether the **EVENT** bit is set to 1.

- **NTR** bit =1: the **EVENT** bit is set.
- **NTR** bit =0: the **EVENT** bit is not set.

This part can be written into and read as required. Its contents are not affected by reading.

- **EVENT**

The **EVENT** part indicates whether an event has occurred since the last reading, it is the "memory" of the condition part. It only indicates events passed on by the transition filters. It is permanently updated by the instrument. This part can only be

read by the user. Reading the register clears it. This part is often equated with the entire register.

- **ENABLE**

The `ENABLE` part determines whether the associated `EVENT` bit contributes to the sum bit (see below). Each bit of the `EVENT` part is "ANDed" with the associated `ENABLE` bit (symbol '&'). The results of all logical operations of this part are passed on to the sum bit via an "OR" function (symbol '+').

`ENABLE` bit = 0: the associated `EVENT` bit does not contribute to the sum bit

`ENABLE` bit = 1: if the associated `EVENT` bit is "1", the sum bit is set to "1" as well.

This part can be written into and read by the user as required. Its contents are not affected by reading.

### Sum bit

The sum bit is obtained from the `EVENT` and `ENABLE` part for each register. The result is then entered into a bit of the `CONDition` part of the higher-order register.

The instrument automatically generates the sum bit for each register. Thus an event can lead to a service request throughout all levels of the hierarchy.

### A.1.5.3 Status Byte (STB) and Service Request Enable Register (SRE)

The `Status Byte` (STB) is already defined in IEEE 488.2. It provides a rough overview of the instrument status by collecting the pieces of information of the lower registers. A special feature is that bit 6 acts as the sum bit of the remaining bits of the status byte.

The STB is read using the command `*STB?` or a serial poll.

The `Status Byte` (STB) is linked to the `Service Request Enable` (SRE) register. Each bit of the STB is assigned a bit in the SRE. Bit 6 of the SRE is ignored. If a bit is set in the SRE and the associated bit in the STB changes from 0 to 1, a service request (SRQ) is generated. The SRE can be set using the command `*SRE` and read using the command `*SRE?`.

**Table A-5: Meaning of the bits used in the status byte**

Bit No.	Meaning
0...1	Not used
2	Error Queue not empty The bit is set when an entry is made in the error queue. If this bit is enabled by the SRE, each entry of the error queue generates a service request. Thus an error can be recognized and specified in greater detail by polling the error queue. The poll provides an informative error message. This procedure is to be recommended since it considerably reduces the problems involved with remote control.
3	QUESTIONable status register summary bit The bit is set if an <code>EVENT</code> bit is set in the <code>QUESTIONable</code> status register and the associated <code>ENABLE</code> bit is set to 1. A set bit indicates a questionable instrument status, which can be specified in greater detail by querying the <code>STATUS:QUESTIONable</code> status register.

Bit No.	Meaning
4	MAV bit (message available) The bit is set if a message is available in the output queue which can be read. This bit can be used to enable data to be automatically read from the instrument to the controller.
5	ESB bit Sum bit of the event status register. It is set if one of the bits in the event status register is set and enabled in the event status enable register. Setting of this bit indicates a serious error which can be specified in greater detail by polling the event status register.
6	MSS bit (master status summary bit) The bit is set if the instrument triggers a service request. This is the case if one of the other bits of this registers is set together with its mask bit in the service request enable register SRE.
7	STATUS:OPERation status register summary bit The bit is set if an EVENT bit is set in the OPERATION status register and the associated ENABLE bit is set to 1. A set bit indicates that the instrument is just performing an action. The type of action can be determined by querying the STATUS:OPERation status register.

#### A.1.5.4 Event Status Register (ESR) and Event Status Enable Register (ESE)

The ESR is defined in IEEE 488.2. It can be compared with the EVENT part of a SCPI register. The event status register can be read out using command `*ESR?`.

The ESE corresponds to the ENABLE part of a SCPI register. If a bit is set in the ESE and the associated bit in the ESR changes from 0 to 1, the ESB bit in the STB is set. The ESE register can be set using the command `*ESE` and read using the command `*ESE?`.

**Table A-6: Meaning of the bits used in the event status register**

Bit No.	Meaning
0	Operation Complete This bit is set on receipt of the command <code>*OPC</code> exactly when all previous commands have been executed.
1	Not used
2	Query Error This bit is set if either the controller wants to read data from the instrument without having sent a query, or if it does not fetch requested data and sends new instructions to the instrument instead. The cause is often a query which is faulty and hence cannot be executed.
3	Device-dependent Error This bit is set if a device-dependent error occurs. An error message with a number between -300 and -399 or a positive error number, which denotes the error in greater detail, is entered into the error queue.
4	Execution Error This bit is set if a received command is syntactically correct but cannot be performed for other reasons. An error message with a number between -200 and -300, which denotes the error in greater detail, is entered into the error queue.

Bit No.	Meaning
5	Command Error This bit is set if a command is received, which is undefined or syntactically incorrect. An error message with a number between -100 and -200, which denotes the error in greater detail, is entered into the error queue.
6	User Request This bit is set when the instrument is switched over to manual control.
7	Power On (supply voltage on) This bit is set on switching on the instrument.

#### A.1.5.5 Questionable Status Register (STATus:QUESTionable)

This register contains information on questionable instrument states. Such states may occur when the instrument is not operated in compliance with its specifications.

To read the register, use the query commands `STAT:QUEST:COND?` or `STAT:QUEST[:EVEN]?`.

*Table A-7: Meaning of the bits used in the questionable status register*

Bit No.	Meaning
0–15	Not used

#### A.1.5.6 Operation Status Register (STATus:OPERation)

This condition part contains information on the actions currently being performed by the instrument, while the event part contains information on the actions performed by the instrument since the last readout of the register.

To read the register, use the query commands `STAT:OPER:COND?` or `STAT:OPER[:EVEN]?`.

*Table A-8: Meaning of the bits used in the operation status register*

Bit No.	Meaning
0	Calibrating The bit is set during the calibration phase.
1–2	Not used
3	Sweeping This bit is set during a sweep in automatic or single mode.
4–15	Not used

#### A.1.5.7 Application of the Status Reporting System

The purpose of the status reporting system is to monitor the status of one or several devices in a measuring system. To do this and react appropriately, the controller must

receive and evaluate the information of all devices. The following standard methods are used:

- **Service request** (SRQ) initiated by the instrument
- **Serial poll** of all devices in the bus system, initiated by the controller to find out who sent an SRQ and why
- Query of a **specific instrument status** by commands
- Query of the **error queue**

### Service Request

Under certain circumstances, the instrument can send a service request (SRQ) to the controller. Usually this service request initiates an interrupt at the controller, to which the control program can react appropriately. An SRQ is always initiated if one or several of bits 2, 4 or 5 of the status byte are set and enabled in the SRE. Each of these bits combines the information of the error queue or the output buffer. To use the possibilities of the service request effectively, all bits should be set to "1" in the enable registers SRE and ESE.

#### Example:

Use command `*OPC` to generate an SRQ .

`*ESE 1` - set bit 0 of ESE (Operation Complete)

`*SRE 32` - set bit 5 of SRE (ESB).

After its settings have been completed, the instrument generates an SRQ.

The SRQ is the only possibility for the instrument to become active on its own. Each controller program should set the instrument such that a service request is initiated in the case of malfunction. The program should react appropriately to the service request.

### Serial Poll

In a serial poll, just as with command `*STB`, the status byte of an instrument is queried. However, the query is realized via interface messages and is thus clearly faster.

The serial poll method is defined in IEEE 488.1 and used to be the only standard possibility for different instruments to poll the status byte. The method also works for instruments which do not adhere to SCPI or IEEE 488.2.

The serial poll is mainly used to obtain a fast overview of the state of several instruments connected to the controller.

### Query of an instrument status

Each part of any status register can be read using queries. There are two types of commands:

- The common commands `*ESR?`, `*IDN?`, `*IST?`, `*STB?` query the higher-level registers.
- The commands of the `STATus` system query the SCPI registers (`STATus:QUEStionable...`)

The returned value is always a decimal number that represents the bit pattern of the queried register. This number is evaluated by the controller program.

Queries are usually used after an SRQ in order to obtain more detailed information on the cause of the SRQ.

### Error Queue

Each error state in the instrument leads to an entry in the error queue. The entries of the error queue are detailed plain text error messages that can be looked up in the Error Log or queried via remote control using `SYSTem:ERRor[:NEXT]?`. Each call of `SYSTem:ERRor[:NEXT]?` provides one entry from the error queue. If no error messages are stored there any more, the instrument responds with 0, "No error".

The error queue should be queried after every SRQ in the controller program as the entries describe the cause of an error more precisely than the status registers. Especially in the test phase of a controller program the error queue should be queried regularly since faulty commands from the controller to the instrument are recorded there as well.

#### A.1.5.8 Reset Values of the Status Reporting System

The following table contains the different commands and events causing the status reporting system to be reset. None of the commands, except of `*RST` and `SYSTem:PRESet` affect the functional instrument settings. In particular, `DCL` does not change the instrument settings.

**Table A-9: Resetting the status reporting system**

Event	Switching on supply voltage Power-On-Status-Clear		DCL, SDC  (Device Clear, Selected Device Clear)	*RST or SYSTem: PRESet	STATus: PRESet	*CLS
	0	1				
Clear STB, ESR	-	Yes	-	-	-	Yes
Clear SRE, ESE	-	Yes	-	-	-	-
Clear PPE	-	Yes	-	-	-	-
Clear error queue	Yes	Yes	-	-	-	Yes
Clear output buffer	Yes	Yes	Yes	1)	1)	1)
Clear command processing and input buffer	Yes	Yes	Yes	-	-	-

1) The first command in a command line that immediately follows a <PROGRAM MESSAGE TERMINATOR> clears the output buffer.

## A.1.6 General Programming Recommendations

### Initial instrument status before changing settings

Manual operation is designed for maximum possible operating convenience. In contrast, the priority of remote control is the "predictability" of the instrument status. Thus, when a command attempts to define incompatible settings, the command is ignored and the instrument status remains unchanged, i.e. other settings are not automatically adapted. Therefore, control programs should always define an initial instrument status (e.g. using the \*RST command) and then implement the required settings.

### Command sequence

As a general rule, send commands and queries in different program messages. Otherwise, the result of the query may vary depending on which operation is performed first (see also Preventing Overlapping Execution).

### Reacting to malfunctions

The service request is the only possibility for the instrument to become active on its own. Each controller program should instruct the instrument to initiate a service request in case of malfunction. The program should react appropriately to the service request.

### Error queues

The error queue should be queried after every service request in the controller program as the entries describe the cause of an error more precisely than the status registers. Especially in the test phase of a controller program the error queue should be queried regularly since faulty commands from the controller to the instrument are recorded there as well.

## A.2 Telnet program examples

The following program example shows a simple `TcpClient` class that is intended to explain on how to get started with programming of sockets.

The example sets up a socket communication to R&S SMA100B and opens a simple user interface, very similar to the telnet, which allows input of commands. To enable real automation, further development of the program is required.

### TcpClient.h

```
#include <string>
//defines structs for socket handling
#include <netinet/in.h>
using namespace std;
typedef struct sockaddr_in SockAddrStruct;
typedef struct hostent      HostInfoStruct;
```



```

class TcpClient
{
public:
    TcpClient();
    ~TcpClient();
    void connectToServer( string &hostname, int port );
    void disconnect( );
    void transmit( string &txString );
    void receive( string &rxString );
    string getCurrentHostName( ) const;
    int    getCurrentPort( ) const;
private:
    string      currentHostName;
    int         currentPort;
    int         currentSocketDescr;
    SockAddrStruct  serverAddress;
    HostInfoStruct * currentHostInfo;
    bool        clientIsConnected;
    int         receiveBufferSize;
};

```

### TcpClient.cpp

```

#include <string>
//defines structs for socket handling
#include <netinet/in.h>
using namespace std;
typedef struct sockaddr_in SockAddrStruct;
typedef struct hostent     HostInfoStruct;
class TcpClient
{
public:
    TcpClient();
    ~TcpClient();
    void connectToServer( string &hostname, int port );
    void disconnect( );
    void transmit( string &txString );
    void receive( string &rxString );
    string getCurrentHostName( ) const;
    int    getCurrentPort( ) const;
private:
    string      currentHostName;
    int         currentPort;
    int         currentSocketDescr;
    SockAddrStruct  serverAddress;
    HostInfoStruct * currentHostInfo;
    bool        clientIsConnected;
    int         receiveBufferSize;
};

```

```

#include <netdb.h>
#include <netinet/in.h>
#include <unistd.h>
#include "TcpClient.h"
TcpClient::TcpClient()
: currentHostName( "" )
, currentPort( 0 )
, currentSocketDescr( 0 )
, serverAddress ( )
, currentHostInfo( NULL )
, clientIsConnected( false )
, receiveBufferSize( 1024 )
{
}
TcpClient::~~TcpClient()
{
    currentHostInfo = NULL;
}

void TcpClient::connectToServer( string &hostname, int port )
{
    currentHostInfo = gethostbyname( hostname.c_str( ) );
    if( currentHostInfo == NULL )
    {
        currentHostName = "";
        currentPort = 0;
        currentHostInfo = NULL;
        clientIsConnected = false;
        printf("error connecting host\n" );
    }
    currentHostName = hostname;
    currentPort = port;
    currentSocketDescr = socket(AF_INET, SOCK_STREAM, 0);
    if( currentSocketDescr == 0 )
    {
        currentHostName = "";
        currentPort = 0;
        currentHostInfo = NULL;
        clientIsConnected = false;
        printf("can't create socket\n" );
    }
    serverAddress.sin_family = currentHostInfo->h_addrtype;
    serverAddress.sin_port = htons( currentPort );
    memcpy( (char *) &serverAddress.sin_addr.s_addr,
        currentHostInfo->h_addr_list[0], currentHostInfo->h_length );
    if( connect( currentSocketDescr, ( struct sockaddr *) &serverAddress,
        sizeof( serverAddress ) ) < 0 )
    {
        throw string("can't connect server\n" );
    }
}

```

```

        clientIsConnected = true;
    }
void TcpClient::disconnect( )
{
    if( clientIsConnected )
    {
        close( currentSocketDescr );
    }
    currentSocketDescr = 0;
    currentHostName    = "";
    currentPort        = 0;
    currentHostInfo    = NULL;
    clientIsConnected = false;
}
void TcpClient::transmit( string &txString )
{
    if( !clientIsConnected )
    {
        throw string("connection must be established before any data can be sent\n");
    }
    char * transmitBuffer = new char[txString.length() +1];
    memcpy( transmitBuffer, txString.c_str(), txString.length() );
    transmitBuffer[txString.length()] = '\n'; //newline is needed!
    if( send( currentSocketDescr, transmitBuffer, txString.length() + 1, 0 ) < 0 )
    {
        throw string("can't transmit data\n");
    }
    delete [] transmitBuffer;
}
void TcpClient::receive( string &rxString )
{
    if( !clientIsConnected )
    {
        throw string("connection must be established before any data can be received\n");
    }
    char * receiveBuffer = new char[receiveBufferSize];
    memset( receiveBuffer, 0, receiveBufferSize );
    bool receiving = true;
    while( receiving )
    {
        int receivedByteCount = recv( currentSocketDescr,
            receiveBuffer, receiveBufferSize, 0 );
        if( receivedByteCount < 0 )
        {
            throw string("error while receiving data\n");
        }
        rxString += string( receiveBuffer );
        receiving = ( receivedByteCount == receiveBufferSize );
    }
    delete [] receiveBuffer;
}

```

```

}
string TcpClient::getCurrentHostName( ) const
{
    return currentHostName;
}
int TcpClient::getCurrentPort( ) const
{
    return currentPort;
}

```

### TelnetClient.cpp

```

#include <iostream>
#include "TcpClient.h"
void printUsage()
{
    cout<<"usage: EthernetRawCommand <server-ip> [scpi-command]"<<endl;
}
int main( int argc, char *argv[] )
{
    int errorCode          = 0; //no error
    bool useSingleCommand = false;
    string singleCommand   = "";
    string hostname        = "";
    int    port            = 5025;
    string input           = "";
    TcpClient client;
    switch( argc )
    {
        case 3:
            useSingleCommand = true;
            singleCommand    = argv[2];
        case 2:
            hostname        = argv[1];
            break;
        default:
            printUsage();
            return(-1);
    }
    try
    {
        client.connectToServer( hostname, port );
        bool terminate = false;
        while( !terminate )
        {
            char buffer[1024];
            if( useSingleCommand )
            {
                input = singleCommand; //send string
            }

```

```

else
{
    cin.getline( buffer, 1024 );
    input = buffer;
    if( input == "end" )
    {
        terminate = true;
    }
}
if( !terminate)
{
    client.transmit( input ); //send string
    int qPos = input.find( "?", 0 );
    //receive string only when needed
    if( qPos > 0 )
    {
        string rcStr = "";
        client.receive( rcStr );
        cout << rcStr << endl;
    }
}
if( useSingleCommand )
{
    terminate = true;
}
}
}catch( const string errorString )
{
    cout<<errorString<<endl;
}
client.disconnect( );
return errorCode;
}

```

## A.3 Extensions for User Files

The [Table A-10](#) lists all available file extensions for user files. The currently available files on the instrument depend on the installed options.

**Table A-10: List of the automatically assigned file extensions in the instrument**

Function	List type	Contents	File suffix
Instrument State	Settings	Instrument settings	*.savrcltxt
User Menu	Settings	User-defined favorite settings	*.user_menu
License Key		License Key	*.xml
"User Correction"	List	User-defined level correction values	*.uco
"List Mode"	List	User-defined frequency/level value pairs	*.lsw

Function	List type	Contents	File suffix
	Settings	Response file	*.txt
"Pulse Train"	Settings	Pulse train data	*.pulstrn
"NRP Settings"	Settings	R&S NRP Settings	*.nrp, *.rsu
SCPI command list	List	Export file containing list of SCPIs	*.iec
SCPI command script		SCPI script file formats: Plain SCPI, MATLAB, NICVI, Python3	*.txt , *.m, *.c, *.py
R&S Support Info Archive	Support File	Automatically collected support information	*.tar.gz
Tutorials	Tutorial files	Lists containing SCPIs and explanations	*.tut

## B Hardware Interfaces

This section covers hardware-related topics, like pin assignment of the IEC 625/IEEE 488 interface.

The remote control interfaces are described in details in [Chapter 13, "Network Operation and Remote Control"](#), on page 371.

All other interfaces are described in [Chapter 3.2, "Instrument Tour"](#), on page 36.

For specifications, refer to the data sheet.

### B.1 GPIB-Bus Interface

Option: R&S SMAB-B86.

#### Pin assignment

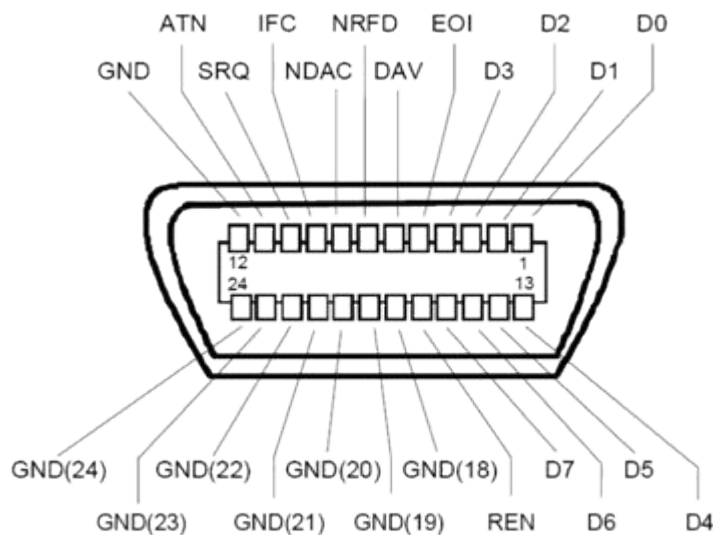

Figure B-1: Pin assignment of GPIB-bus (IEEE 488) interface

#### Bus lines

- Data bus with 8 lines D0 to D7:  
The transmission is bit-parallel and byte-serial in the ASCII/ISO code. D0 is the least significant bit, D7 the most significant bit.
- Control bus with five lines:  
**IFC** (Interface Clear): active LOW resets the interfaces of the instruments connected to the default setting.  
**ATN** (Attention): active LOW signals the transmission of interface messages, inactive HIGH signals the transmission of device messages.

**SRQ** (Service Request): active LOW enables the connected device to send a service request to the controller.

**REN** (Remote Enable): active LOW permits switchover to remote control.

**EOI** (End or Identify): has two functions in connection with ATN:

- ATN=HIGH active LOW marks the end of data transmission.
- ATN=LOW active LOW triggers a parallel poll.

- Handshake bus with three lines:

**DAV** (Data Valid): active LOW signals a valid data byte on the data bus.

**NRFD** (Not Ready For Data): active LOW signals that one of the connected devices is not ready for data transfer.

**NDAC** (Not Data Accepted): active LOW signals that the instrument connected is accepting the data on the data bus.

### Interface functions

Instruments which can be controlled via GPIB-bus interface can be equipped with different interface functions. [Table B-1](#) lists the interface functions for the R&S SMA100B.

**Table B-1: GPIB-bus interface functions**

Control character	Interface function
SH1	Handshake source function (source handshake), full capability
AH1	Handshake sink function (acceptor handshake), full capability
L4	Listener function, full capability, de-addressed by MTA.
T6	Talker function, full capability, ability to respond to serial poll, deaddressed by MLA
SR1	Service request function (Service Request), full capability
PP1	Parallel poll function, full capability
RL1	Remote/Local switch over function, full capability
DC1	Reset function (Device Clear), full capability
DT1	Trigger function (Device Trigger), full capability



## C Morse Code Settings

The COM/ID tone is sent according to the selected code (see [Table C-1](#)). The length of the Morse code can be varied. For selected standard time scheme, the selected dot length determines the setting of all other length parameters of the Morse code (dash length, symbol space and letter space). For selected user time scheme, all length parameters of the code can be set independently. If no coding is entered, the COM/ID tone is sent uncoded (key down).



The following values are default values:

- A dot (.) has a tone duration of 100 ms
- A dash (-) has a tone duration of 300ms
- The time between two tones is 100ms
- The time between two letters is 300ms

After each word, a word space is entered. The word repetition rate is 7 words per minute. Since the word length can vary between 900 ms and 4500 ms, the word space between the words varies accordingly.

### Example:

ID code = MUC

The word length =

$(300+100+300)+300+(100+100+100+100+300)+300+(300+100+100+100+300+100+100) = 3100$  ms

**Table C-1: Morse code**

Letter	Morse code	Letter	Morse code
A	.-	N	-. .
B	-... .	O	---
C	-... .	P	.-... .
D	-... .	Q	---..
E	.	R	.-..
F	... .	S	... .
G	... .	T	-
H	....	U	...-
I	..	V	...-.
J	....	W	...-
K	-. .	X	-...-
L	.-... .	Y	-.---
M	--	Z	---..

# Glossary: List of the Often Used Terms and Abbreviations

## Symbols

**1MA193:** 1MA193\_0e Application Note, "Aeronautical radio navigation measurement solutions"

### A

**Absolute file path:** [Complete file path](#)

### B

**Base unit:** This term describes a R&S SMA100B equipped with the option R&S SMAB-B103.

### C

**Clock:** A mandatory internal or an external reference clock signal for generating the timing pulse in the instrument.

**Complete file path:** The complete file path specifies the root directory and all subdirectories that contain a file or folder.

See also [Chapter 14.5.2, "Accessing Files in the Default or in a Specified Directory"](#), on page 443.

**Computer name:** An unambiguous indication of the instrument in a LAN that uses a [DNS](#) server.

The default computer name follows the syntax `SMAB-<serial number>`, e.g. `SMA100B-102030`.

Synonym: [Hostname](#)

See [Serial number](#).

### D

**daisy chain:** A connection scheme in which instruments are connected together in sequence, i.e. an output of the first one is connected to an input of the second one, etc.

**DHCP:** Dynamic host configuration protocol

**DNS:** Domain name system server

### E

**e.g.:** For example

**External mass memory:** External memory, connected to the instrument via USB connector (Type A female). It can hold stored files with user data.

See also [System drive](#) and [SD card](#)

**F**

**File transfer:** The transmission of files from or to the instrument by a remote client. The instrument supports the standard methods [FTP](#) and file sharing according to [SAMBA/SMB](#).

**FTP:** File transfer protocol

**Full file path:** [Complete file path](#)

**G**

**Glossary:** List of the often used terms and abbreviations

**GUI:** Graphical user interface

**H**

**HDD:** Hard disk drive, see [System drive](#)

**Hostname:** [Computer name](#)

**I**

**i.e.:** That is

**L**

**LF:** Low frequency

**LSB:** Least significant bit

**M**

**MIMO:** Multiple input multiple output

**MSB:** Most significant bit

**P**

**PC:** Personal computer

**Power:** A term describing the signal level of the RF signal

**product page:** A designation of the R&S SMA100B product page <http://www.rohde-schwarz.com/product/SMA100B.html>

**R**

**Remote access:** [Remote operation](#)

**Remote control:** The operation of the R&S SMA100B by remote control commands or programs to perform automated tests.

The instrument is connected to a system controller via LAN/VXI-11, GPIB or USB using [VISA](#). The instrument is controlled directly or supported by instrument drivers.

**Remote device:** External device controls the R&S SMA100B in remote operation mode, see [Remote operation](#).

Synonyms: External controller, client device

**Remote operation:** Allows you to operate the R&S SMA100B from a remote device via VNC.

Both the R&S SMA100B and the remote device are connected in a LAN.

Synonym: Remote access

**Removable memory:** General term describing mass memory that can be unmounted from the instrument.

See also [SD card](#)

**RF:** Radio frequency

## S

**SAMBA/SMB:** Server message protocol

**SD card:** Secure digital card is a type of removable memory storage, that can hold files with user data.

Support of this memory type is optional and requires option R&S SMAB-B85.

Throughout this description, the SD card is referred as a removable memory.

See also [System drive](#).

**Serial number:** Unique instrument identification, provided on the rear panel of the instrument and required to build the [Computer name](#).

The serial number are the last 6 digits in the string `<stock no.>-<serial number>`, e.g. SMA100B-102030

**Smart device:** A mobile, cordless device, such as a smartphone or tablet, capable of Internet browsing.

Synonyms: Smartphone, tablet

**System drive:** The system drive is a built-in internal memory that holds the operating system, the firmware, and the stored user data.

Throughout this description, the system drive is referred as an internal memory.

See also [SD card](#) and [Removable memory](#)

## T

**Trigger:** Internally generated or externally supplied signal which starts signal generation at a particular point in time

**Trigger event:** A trigger event is caused by the received trigger signal or executed manual trigger.

**U**

**UE:** User equipment

**USBTMC:** (USB test & measurement class)

A protocol built on top of USB for communication with USB devices. Using [VISA](#) library, it supports service request, triggers, and other specific operations, similar to GPIB.

**User directory:** Describes the default file storage location for user data.

Depending on the installed options, the user directory is physically located on the [System drive](#) or on the [Removable memory](#)

In the file system, user directory is always indicated as `/var/user`

**V**

**VISA:** Virtual instrument software architecture

# List of Commands

:CALCulate[:POWer]:SWEep:FREQuency:MATH<ch>:STATe.....	479
:CALCulate[:POWer]:SWEep:FREQuency:MATH<ch>:SUBTract.....	480
:CALCulate[:POWer]:SWEep:POWer:MATH<ch>:STATe.....	480
:CALCulate[:POWer]:SWEep:POWer:MATH<ch>:SUBTract.....	480
:CALCulate[:POWer]:SWEep:TIME:GATE<ch>:AVERAge?.....	481
:CALCulate[:POWer]:SWEep:TIME:GATE<ch>:FEED.....	481
:CALCulate[:POWer]:SWEep:TIME:GATE<ch>:MAXimum?.....	481
:CALCulate[:POWer]:SWEep:TIME:GATE<ch>:START.....	482
:CALCulate[:POWer]:SWEep:TIME:GATE<ch>:STATe.....	482
:CALCulate[:POWer]:SWEep:TIME:GATE<ch>:STOP.....	482
:CALCulate[:POWer]:SWEep:TIME:MATH<ch>:STATe.....	483
:CALCulate[:POWer]:SWEep:TIME:MATH<ch>:SUBTract.....	483
:CALibration:ALL[:MEASure]?.....	452
:CALibration:DATA:FACTory:DATE?.....	454
:CALibration<hw>:ALL:DATE?.....	452
:CALibration<hw>:ALL:INFormation?.....	453
:CALibration<hw>:ALL:TEMP?.....	453
:CALibration<hw>:ALL:TIME?.....	453
:CALibration<hw>:CONTInueonerror.....	454
:CSYNthesis:FREQuency.....	456
:CSYNthesis:FREQuency:STEP.....	459
:CSYNthesis:FREQuency:STEP:MODE.....	458
:CSYNthesis:OFFSet.....	457
:CSYNthesis:OFFSet:STATe.....	457
:CSYNthesis:OTYPE.....	456
:CSYNthesis:PHASe.....	457
:CSYNthesis:PHASe:REFerence.....	458
:CSYNthesis:POWer.....	456
:CSYNthesis:POWer:STEP:MODE.....	458
:CSYNthesis:POWer:STEP[:INCRement].....	458
:CSYNthesis:STATe.....	455
:CSYNthesis:VOLTagE.....	457
:DEVice:PRESet.....	440
:DIAGnostic:INFO:OTIME?.....	461
:DIAGnostic:INFO:POCounT?.....	461
:DIAGnostic<hw>:BGINfo:CATalog?.....	460
:DIAGnostic<hw>:BGINfo?.....	460
:DIAGnostic<hw>:POINt:CATalog?.....	462
:DIAGnostic<hw>[:MEASure]:POINt?.....	462
:DISPlay:ANNotation:AMPLitude.....	465
:DISPlay:ANNotation:FREQuency.....	465
:DISPlay:ANNotation[:ALL].....	465
:DISPlay:BRIGhtness.....	464
:DISPlay:BUtTon:BRIGhtness.....	464
:DISPlay:DIALog:CLOSe.....	466
:DISPlay:DIALog:CLOSe:ALL.....	467
:DISPlay:DIALog:ID?.....	465

:DISPlay:DIALog:OPEN.....	466
:DISPlay:PSAVe:HOLDoff.....	463
:DISPlay:PSAVe[:STATe].....	464
:DISPlay:UPDate.....	464
:DISPlay[:WINDow][:POWer]:SWEep:BACKground:COLor.....	483
:DISPlay[:WINDow][:POWer]:SWEep:GRID:STATe.....	484
:FORMat:BORDER.....	467
:FORMat:SREGister.....	468
:FORMat[:DATA].....	468
:HCOPy:DATA?.....	470
:HCOPy:DEVice:LANGUage.....	470
:HCOPy:FILE[:NAME].....	470
:HCOPy:FILE[:NAME]:AUTO:DIRectory.....	471
:HCOPy:FILE[:NAME]:AUTO:DIRectory:CLEar.....	472
:HCOPy:FILE[:NAME]:AUTO:FILE?.....	472
:HCOPy:FILE[:NAME]:AUTO:STATe.....	472
:HCOPy:FILE[:NAME]:AUTO?.....	471
:HCOPy:FILE[:NAME]:AUTO[:FILE]:DAY:STATe.....	472
:HCOPy:FILE[:NAME]:AUTO[:FILE]:MONTH:STATe.....	472
:HCOPy:FILE[:NAME]:AUTO[:FILE]:NUMBer?.....	473
:HCOPy:FILE[:NAME]:AUTO[:FILE]:PREFix.....	473
:HCOPy:FILE[:NAME]:AUTO[:FILE]:PREFix:STATe.....	473
:HCOPy:FILE[:NAME]:AUTO[:FILE]:YEAR:STATe.....	472
:HCOPy:IMAGe:FORMat.....	470
:HCOPy:REGion.....	470
:HCOPy[:EXECute].....	471
:INITiate<hw>[:POWer]:CONTinuous.....	484
:INITiate<hw>[:POWer]:CONTinuous.....	533
:KBOARD:LAYout.....	474
:MEMory:HFRee?.....	451
:MMEMory:CATalog:LENGth?.....	447
:MMEMory:CATalog?.....	446
:MMEMory:CDIRectory.....	447
:MMEMory:COPIY.....	447
:MMEMory:DATA.....	448
:MMEMory:DCATalog:LENGth?.....	449
:MMEMory:DCATalog?.....	449
:MMEMory:DELeTe.....	449
:MMEMory:LOAD:STATe.....	449
:MMEMory:MDIRectory.....	450
:MMEMory:MOVE.....	450
:MMEMory:MSIS.....	450
:MMEMory:RDIRectory.....	451
:MMEMory:STORe:STATe.....	451
:OUTPut:ALL[:STATe].....	474
:OUTPut:FPRoportional:SCALE.....	476
:OUTPut:USER:MARKer.....	477
:OUTPut<hw>:AFIXed:RANGe:LOWer?.....	477
:OUTPut<hw>:AFIXed:RANGe:UPPer?.....	477
:OUTPut<hw>:AMODE.....	475

:OUTPut<hw>:FILTer:MODE.....	476
:OUTPut<hw>:IMPedance?.....	476
:OUTPut<hw>:PROTection:CLEar.....	477
:OUTPut<hw>:PROTection:TRIPped?.....	478
:OUTPut<hw>[:STATe].....	475
:OUTPut<hw>[:STATe]:PON.....	475
:READ<ch>[:POWer]?.....	534
:SENSe[:POWer]:SWEep:ABORT.....	495
:SENSe[:POWer]:SWEep:FREQuency:REFerence:DATA:COPIY.....	495
:SENSe[:POWer]:SWEep:FREQuency:REFerence:DATA:POINts?.....	495
:SENSe[:POWer]:SWEep:FREQuency:REFerence:DATA:XVALues.....	495
:SENSe[:POWer]:SWEep:FREQuency:REFerence:DATA:YVALues.....	496
:SENSe[:POWer]:SWEep:FREQuency:RMODE.....	496
:SENSe[:POWer]:SWEep:FREQuency:SPACing[:MODE].....	496
:SENSe[:POWer]:SWEep:FREQuency:STARt.....	496
:SENSe[:POWer]:SWEep:FREQuency:STEPs.....	497
:SENSe[:POWer]:SWEep:FREQuency:STOP.....	497
:SENSe[:POWer]:SWEep:FREQuency:TIMing[:MODE].....	497
:SENSe[:POWer]:SWEep:FREQuency:YScale:AUTO.....	498
:SENSe[:POWer]:SWEep:FREQuency:YScale:AUTO:RESet.....	498
:SENSe[:POWer]:SWEep:FREQuency:YScale:MAXimum.....	498
:SENSe[:POWer]:SWEep:FREQuency:YScale:MINimum.....	499
:SENSe[:POWer]:SWEep:HCOPY:DATA?.....	499
:SENSe[:POWer]:SWEep:HCOPY:DEVIce.....	500
:SENSe[:POWer]:SWEep:HCOPY:DEVIce:LANGUage.....	501
:SENSe[:POWer]:SWEep:HCOPY:DEVIce:LANGUage:CSV:DPOint.....	501
:SENSe[:POWer]:SWEep:HCOPY:DEVIce:LANGUage:CSV:HEADer.....	501
:SENSe[:POWer]:SWEep:HCOPY:DEVIce:LANGUage:CSV:ORIEntation.....	502
:SENSe[:POWer]:SWEep:HCOPY:DEVIce:LANGUage:CSV[:COLUmN]:SEPArator.....	502
:SENSe[:POWer]:SWEep:HCOPY:DEVIce:SIZE.....	502
:SENSe[:POWer]:SWEep:HCOPY:FILE[:NAME].....	503
:SENSe[:POWer]:SWEep:HCOPY:FILE[:NAME]:AUTO:DIRectory.....	503
:SENSe[:POWer]:SWEep:HCOPY:FILE[:NAME]:AUTO:DIRectory:CLEar.....	503
:SENSe[:POWer]:SWEep:HCOPY:FILE[:NAME]:AUTO:FILE?.....	504
:SENSe[:POWer]:SWEep:HCOPY:FILE[:NAME]:AUTO:STATe.....	504
:SENSe[:POWer]:SWEep:HCOPY:FILE[:NAME]:AUTO[:FILE]:DAY:STATe.....	505
:SENSe[:POWer]:SWEep:HCOPY:FILE[:NAME]:AUTO[:FILE]:DAY?.....	504
:SENSe[:POWer]:SWEep:HCOPY:FILE[:NAME]:AUTO[:FILE]:MONTH:STATe.....	505
:SENSe[:POWer]:SWEep:HCOPY:FILE[:NAME]:AUTO[:FILE]:MONTH?.....	505
:SENSe[:POWer]:SWEep:HCOPY:FILE[:NAME]:AUTO[:FILE]:NUMBer?.....	506
:SENSe[:POWer]:SWEep:HCOPY:FILE[:NAME]:AUTO[:FILE]:PREFix.....	506
:SENSe[:POWer]:SWEep:HCOPY:FILE[:NAME]:AUTO[:FILE]:PREFix:STATe.....	506
:SENSe[:POWer]:SWEep:HCOPY:FILE[:NAME]:AUTO[:FILE]:YEAR:STATe.....	507
:SENSe[:POWer]:SWEep:HCOPY:FILE[:NAME]:AUTO[:FILE]:YEAR?.....	506
:SENSe[:POWer]:SWEep:HCOPY[:EXECute].....	507
:SENSe[:POWer]:SWEep:INITiate.....	507
:SENSe[:POWer]:SWEep:MODE.....	507
:SENSe[:POWer]:SWEep:POWer:REFerence:DATA:COPIY.....	508
:SENSe[:POWer]:SWEep:POWer:REFerence:DATA:POINts?.....	508
:SENSe[:POWer]:SWEep:POWer:REFerence:DATA:XVALues.....	508



:SENSe[:POWer]:SWEep:POWer:REFerence:DATA:YVALues.....	508
:SENSe[:POWer]:SWEep:POWer:RMODe.....	509
:SENSe[:POWer]:SWEep:POWer:SPACing[:MODE].....	509
:SENSe[:POWer]:SWEep:POWer:STARt.....	509
:SENSe[:POWer]:SWEep:POWer:STEPs.....	509
:SENSe[:POWer]:SWEep:POWer:STOP.....	510
:SENSe[:POWer]:SWEep:POWer:TIMing[:MODE].....	510
:SENSe[:POWer]:SWEep:POWer:YSCale:AUTO.....	510
:SENSe[:POWer]:SWEep:POWer:YSCale:AUTO:RESet.....	511
:SENSe[:POWer]:SWEep:POWer:YSCale:MAXimum.....	511
:SENSe[:POWer]:SWEep:POWer:YSCale:MINimum.....	512
:SENSe[:POWer]:SWEep:RMODe.....	512
:SENSe[:POWer]:SWEep:TIME:AVERAge[:COUNT].....	512
:SENSe[:POWer]:SWEep:TIME:REFerence:DATA:COpy.....	513
:SENSe[:POWer]:SWEep:TIME:REFerence:DATA:POINts?.....	513
:SENSe[:POWer]:SWEep:TIME:REFerence:DATA:XVALues.....	513
:SENSe[:POWer]:SWEep:TIME:REFerence:DATA:YVALues.....	513
:SENSe[:POWer]:SWEep:TIME:RMODe.....	514
:SENSe[:POWer]:SWEep:TIME:SPACing[:MODE].....	514
:SENSe[:POWer]:SWEep:TIME:STARt.....	514
:SENSe[:POWer]:SWEep:TIME:STEPs.....	514
:SENSe[:POWer]:SWEep:TIME:STOP.....	515
:SENSe[:POWer]:SWEep:TIME:TEVents.....	515
:SENSe[:POWer]:SWEep:TIME:YSCale:AUTO.....	515
:SENSe[:POWer]:SWEep:TIME:YSCale:AUTO:RESet.....	516
:SENSe[:POWer]:SWEep:TIME:YSCale:MAXimum.....	516
:SENSe[:POWer]:SWEep:TIME:YSCale:MINimum.....	517
:SENSe<ch>:UNIT[:POWer].....	534
:SENSe<ch>[:POWer]:APERture:DEFault:STATe.....	535
:SENSe<ch>[:POWer]:APERture:TIME.....	535
:SENSe<ch>[:POWer]:CORRection:SPDeVice:LIST?.....	536
:SENSe<ch>[:POWer]:CORRection:SPDeVice:SElect.....	535
:SENSe<ch>[:POWer]:CORRection:SPDeVice:STATe.....	536
:SENSe<ch>[:POWer]:DISPlay:PERManent:PRiority.....	536
:SENSe<ch>[:POWer]:DISPlay:PERManent:STATe.....	536
:SENSe<ch>[:POWer]:FILTer:LENGth:AUTO?.....	537
:SENSe<ch>[:POWer]:FILTer:LENGth[:USER].....	537
:SENSe<ch>[:POWer]:FILTer:NSRatio.....	538
:SENSe<ch>[:POWer]:FILTer:NSRatio:MTIME.....	538
:SENSe<ch>[:POWer]:FILTer:SONCe.....	538
:SENSe<ch>[:POWer]:FILTer:TYPE.....	539
:SENSe<ch>[:POWer]:FREQuency.....	539
:SENSe<ch>[:POWer]:LOGGing:STATe.....	540
:SENSe<ch>[:POWer]:OFFSet.....	540
:SENSe<ch>[:POWer]:OFFSet:STATe.....	540
:SENSe<ch>[:POWer]:SNUMber?.....	540
:SENSe<ch>[:POWer]:SOURce.....	541
:SENSe<ch>[:POWer]:STATus[:DEVice]?.....	541
:SENSe<ch>[:POWer]:SVERSion?.....	541
:SENSe<ch>[:POWer]:SWEep:FREQuency[:SENSor]:OFFSet.....	486

:SENSe<ch>[:POWER]:SWEep:FREQuency[:SENSor]:OFFSet:STATe.....	487
:SENSe<ch>[:POWER]:SWEep:FREQuency[:SENSor]:SRANge:START.....	487
:SENSe<ch>[:POWER]:SWEep:FREQuency[:SENSor]:SRANge:STOP.....	487
:SENSe<ch>[:POWER]:SWEep:FREQuency[:SENSor]:SRANge[:STATe].....	488
:SENSe<ch>[:POWER]:SWEep:POWER[:SENSor]:OFFSet.....	488
:SENSe<ch>[:POWER]:SWEep:POWER[:SENSor]:OFFSet:STATe.....	489
:SENSe<ch>[:POWER]:SWEep:POWER[:SENSor]:SFRequency.....	489
:SENSe<ch>[:POWER]:SWEep:POWER[:SENSor]:SFRequency:STATe.....	489
:SENSe<ch>[:POWER]:SWEep:TIME[:SENSor]:OFFSet.....	490
:SENSe<ch>[:POWER]:SWEep:TIME[:SENSor]:OFFSet:STATe.....	490
:SENSe<ch>[:POWER]:SWEep:TIME[:SENSor]:PULSe:STATe.....	490
:SENSe<ch>[:POWER]:SWEep:TIME[:SENSor]:PULSe:THReshold:BASE.....	491
:SENSe<ch>[:POWER]:SWEep:TIME[:SENSor]:PULSe:THReshold:POWER:HREFerence.....	491
:SENSe<ch>[:POWER]:SWEep:TIME[:SENSor]:PULSe:THReshold:POWER:LREFerence.....	491
:SENSe<ch>[:POWER]:SWEep:TIME[:SENSor]:PULSe:THReshold:POWER:REFerence.....	492
:SENSe<ch>[:POWER]:SWEep:TIME[:SENSor]:SFRequency.....	492
:SENSe<ch>[:POWER]:SWEep:TIME[:SENSor]:SFRequency:STATe.....	492
:SENSe<ch>[:POWER]:SWEep:TIME[:SENSor]:TRIGger:AUTO.....	493
:SENSe<ch>[:POWER]:SWEep:TIME[:SENSor]:TRIGger:DTIME.....	493
:SENSe<ch>[:POWER]:SWEep:TIME[:SENSor]:TRIGger:HYSTeresis.....	493
:SENSe<ch>[:POWER]:SWEep:TIME[:SENSor]:TRIGger:LEVel.....	494
:SENSe<ch>[:POWER]:SWEep:TIME[:SENSor]:TRIGger:SLOPe.....	494
:SENSe<ch>[:POWER]:SWEep:TIME[:SENSor]:TRIGger:SOURce.....	494
:SENSe<ch>[:POWER]:TYPE?.....	542
:SENSe<ch>[:POWER]:ZERO.....	494
:SENSe<ch>[:POWER]:ZERO.....	542
:SLISt:CLear:LAN.....	532
:SLISt:CLear:USB.....	532
:SLISt:CLear[:ALL].....	532
:SLISt:ELEMent<ch>:MAPPing.....	533
:SLISt:SCAN:LSENSor.....	531
:SLISt:SCAN:USENSor.....	532
:SLISt:SCAN[:STATe].....	531
:SLISt:SENSor:MAP.....	533
:SLISt[:LIST]?.....	531
:SOURce<hw>:PRESet.....	440
:STATus:OPERation:CONDition?.....	715
:STATus:OPERation:ENABLE.....	715
:STATus:OPERation:NTRansition.....	716
:STATus:OPERation:PTRansition.....	716
:STATus:OPERation[:EVENT].....	716
:STATus:PRESet.....	716
:STATus:QUESTionable:CONDition.....	717
:STATus:QUESTionable:ENABLE.....	717
:STATus:QUESTionable:NTRansition.....	717
:STATus:QUESTionable:PTRansition.....	718
:STATus:QUESTionable[:EVENT].....	717
:STATus:QUEEue[:NEXT]?.....	718
:SWEep:TYPE.....	679
:SYSTem:BIOS:VERSion?.....	712

:SYSTem:COMMunicate:GPIB:LTERminator.....	699
:SYSTem:COMMunicate:GPIB:RESource?.....	700
:SYSTem:COMMunicate:GPIB[:SELF]:ADDRess.....	700
:SYSTem:COMMunicate:HISLip:RESource?.....	700
:SYSTem:COMMunicate:NETWork:IPADdress.....	700
:SYSTem:COMMunicate:NETWork:IPADdress:MODE.....	701
:SYSTem:COMMunicate:NETWork:MACAddress.....	701
:SYSTem:COMMunicate:NETWork:RESource?.....	701
:SYSTem:COMMunicate:NETWork:REStart.....	702
:SYSTem:COMMunicate:NETWork:STATus?.....	702
:SYSTem:COMMunicate:NETWork[:COMMON]:DOMain.....	702
:SYSTem:COMMunicate:NETWork[:COMMON]:HOSTname.....	702
:SYSTem:COMMunicate:NETWork[:COMMON]:WORKgroup.....	703
:SYSTem:COMMunicate:NETWork[:IPADdress]:DNS.....	703
:SYSTem:COMMunicate:NETWork[:IPADdress]:GATeway.....	703
:SYSTem:COMMunicate:NETWork[:IPADdress]:SUBNet:MASK.....	703
:SYSTem:COMMunicate:SERial:BAUD.....	703
:SYSTem:COMMunicate:SERial:PARity.....	704
:SYSTem:COMMunicate:SERial:RESource?.....	704
:SYSTem:COMMunicate:SERial:SBITs.....	704
:SYSTem:COMMunicate:SOCKet:RESource?.....	704
:SYSTem:COMMunicate:USB:RESource?.....	705
:SYSTem:DATE.....	710
:SYSTem:DFPR?.....	713
:SYSTem:DLOCK.....	696
:SYSTem:ERRor:ALL?.....	693
:SYSTem:ERRor:CODE:ALL?.....	693
:SYSTem:ERRor:CODE[:NEXT]?.....	694
:SYSTem:ERRor:COUNT?.....	694
:SYSTem:ERRor:GNEXt?.....	695
:SYSTem:ERRor:HISTory:CLEar.....	695
:SYSTem:ERRor:STATic?.....	695
:SYSTem:ERRor[:NEXT]?.....	694
:SYSTem:FILEs:TEMPorary:DELeTe.....	714
:SYSTem:FPReset.....	441
:SYSTem:HELP:EXPort.....	705
:SYSTem:IDENtification.....	705
:SYSTem:IDENtification:PRESet.....	706
:SYSTem:INFormation:SCPI.....	707
:SYSTem:IRESpone.....	706
:SYSTem:KLOCK.....	696
:SYSTem:LANGuage.....	707
:SYSTem:LOCK:OWNer?.....	697
:SYSTem:LOCK:RELease:ALL.....	697
:SYSTem:LOCK:REQUest[:EXCLusive]?.....	697
:SYSTem:MMEMory:PATH:USER?.....	713
:SYSTem:NINFormation?.....	696
:SYSTem:NTP:HOSTname.....	711
:SYSTem:NTP:STATe.....	711
:SYSTem:ORESpone.....	706

:SYSTem:OSYStem?	713
:SYSTem:PRESet	441
:SYSTem:PROTect<ch>[:STATe]	698
:SYSTem:RCL	698
:SYSTem:REBoot	714
:SYSTem:RESart	714
:SYSTem:SAV	698
:SYSTem:SECurity:SANitize[:STATe]	707
:SYSTem:SECurity:SUPolicy	707
:SYSTem:SECurity:VOLMode[:STATe]	699
:SYSTem:SHUTdown	714
:SYSTem:SPECification:IDENtification:CATalog?	709
:SYSTem:SPECification:PARAmeter?	709
:SYSTem:SPECification:VERSion	708
:SYSTem:SPECification:VERSion:CATalog?	709
:SYSTem:SPECification:VERSion:FACTory?	710
:SYSTem:SPECification?	707
:SYSTem:SRData?	710
:SYSTem:STARtup:COMPLete?	710
:SYSTem:TIME	711
:SYSTem:TIME:ZONE	712
:SYSTem:TIME:ZONE:CATalog?	712
:SYSTem:ULOCK	696
:SYSTem:UPTime?	712
:SYSTem:VERSion?	713
:SYSTem:WAIT	714
:TEST<hw>:ALL:RESult?	719
:TEST<hw>:ALL:STARt	719
:TRACe[:POWer]:SWEep:MEASurement:FULLscreen:DISPlay:ANNotation[:STATe]	525
:TRACe[:POWer]:SWEep:MEASurement:GATE:DISPlay:ANNotation[:STATe]	526
:TRACe[:POWer]:SWEep:MEASurement:MARKer:DISPlay:ANNotation[:STATe]	526
:TRACe[:POWer]:SWEep:MEASurement:PULSe:DISPlay:ANNotation[:STATe]	526
:TRACe[:POWer]:SWEep:MEASurement:STANdard:DISPlay:ANNotation[:STATe]	527
:TRACe<ch>[:POWer]:SWEep:COLor	518
:TRACe<ch>[:POWer]:SWEep:COPY	519
:TRACe<ch>[:POWer]:SWEep:DATA:POINTs?	519
:TRACe<ch>[:POWer]:SWEep:DATA:XVALues?	519
:TRACe<ch>[:POWer]:SWEep:DATA:YSValue?	520
:TRACe<ch>[:POWer]:SWEep:DATA:YVALues?	520
:TRACe<ch>[:POWer]:SWEep:FEED	520
:TRACe<ch>[:POWer]:SWEep:MEASurement:POWer:AVERage:DISPlay:ANNotation[:STATe]	522
:TRACe<ch>[:POWer]:SWEep:MEASurement:POWer:AVERage?	521
:TRACe<ch>[:POWer]:SWEep:MEASurement:POWer:HREFerence:DISPlay:ANNotation[:STATe]	522
:TRACe<ch>[:POWer]:SWEep:MEASurement:POWer:HREFerence?	521
:TRACe<ch>[:POWer]:SWEep:MEASurement:POWer:LREFerence:DISPlay:ANNotation[:STATe]	522
:TRACe<ch>[:POWer]:SWEep:MEASurement:POWer:LREFerence?	521
:TRACe<ch>[:POWer]:SWEep:MEASurement:POWer:MAXimum:DISPlay:ANNotation[:STATe]	522
:TRACe<ch>[:POWer]:SWEep:MEASurement:POWer:MAXimum?	521
:TRACe<ch>[:POWer]:SWEep:MEASurement:POWer:MINimum:DISPlay:ANNotation[:STATe]	522
:TRACe<ch>[:POWer]:SWEep:MEASurement:POWer:MINimum?	521

:TRACe<ch>[:POWer]:SWEep:MEASurement:POWer:PULSe:BASE:DISPlay:ANNOtation[:STATe].....	522
:TRACe<ch>[:POWer]:SWEep:MEASurement:POWer:PULSe:BASE?.....	521
:TRACe<ch>[:POWer]:SWEep:MEASurement:POWer:PULSe:TOP:DISPlay:ANNOtation[:STATe].....	522
:TRACe<ch>[:POWer]:SWEep:MEASurement:POWer:PULSe:TOP?.....	521
:TRACe<ch>[:POWer]:SWEep:MEASurement:POWer:REFerence:DISPlay:ANNOtation[:STATe].....	522
:TRACe<ch>[:POWer]:SWEep:MEASurement:POWer:REFerence?.....	521
:TRACe<ch>[:POWer]:SWEep:MEASurement:PULSe:ALL:DISPlay:ANNOtation[:STATe].....	523
:TRACe<ch>[:POWer]:SWEep:MEASurement:PULSe:DCYClE:DISPlay:ANNOtation[:STATe].....	522
:TRACe<ch>[:POWer]:SWEep:MEASurement:PULSe:DCYClE?.....	521
:TRACe<ch>[:POWer]:SWEep:MEASurement:PULSe:DURation:DISPlay:ANNOtation[:STATe].....	522
:TRACe<ch>[:POWer]:SWEep:MEASurement:PULSe:DURation?.....	521
:TRACe<ch>[:POWer]:SWEep:MEASurement:PULSe:PERiod:DISPlay:ANNOtation[:STATe].....	522
:TRACe<ch>[:POWer]:SWEep:MEASurement:PULSe:PERiod?.....	521
:TRACe<ch>[:POWer]:SWEep:MEASurement:PULSe:SEPARation:DISPlay:ANNOtation[:STATe].....	522
:TRACe<ch>[:POWer]:SWEep:MEASurement:PULSe:SEPARation?.....	521
:TRACe<ch>[:POWer]:SWEep:MEASurement:PULSe:STATe?.....	521
:TRACe<ch>[:POWer]:SWEep:MEASurement:TRANSition:NEGative:DURation:DISPlay: ANNOtation[:STATe].....	522
:TRACe<ch>[:POWer]:SWEep:MEASurement:TRANSition:NEGative:DURation?.....	521
:TRACe<ch>[:POWer]:SWEep:MEASurement:TRANSition:NEGative:OCCurrence:DISPlay: ANNOtation[:STATe].....	522
:TRACe<ch>[:POWer]:SWEep:MEASurement:TRANSition:NEGative:OCCurrence?.....	521
:TRACe<ch>[:POWer]:SWEep:MEASurement:TRANSition:NEGative:OVERshoot:DISPlay: ANNOtation[:STATe].....	522
:TRACe<ch>[:POWer]:SWEep:MEASurement:TRANSition:NEGative:OVERshoot?.....	521
:TRACe<ch>[:POWer]:SWEep:MEASurement:TRANSition:POSitive:DURation:DISPlay: ANNOtation[:STATe].....	522
:TRACe<ch>[:POWer]:SWEep:MEASurement:TRANSition:POSitive:DURation?.....	521
:TRACe<ch>[:POWer]:SWEep:MEASurement:TRANSition:POSitive:OCCurrence:DISPlay: ANNOtation[:STATe].....	523
:TRACe<ch>[:POWer]:SWEep:MEASurement:TRANSition:POSitive:OCCurrence?.....	521
:TRACe<ch>[:POWer]:SWEep:MEASurement:TRANSition:POSitive:OVERshoot:DISPlay: ANNOtation[:STATe].....	523
:TRACe<ch>[:POWer]:SWEep:MEASurement:TRANSition:POSitive:OVERshoot?.....	521
:TRACe<ch>[:POWer]:SWEep:PULSe:THReshold:BASE?.....	523
:TRACe<ch>[:POWer]:SWEep:PULSe:THReshold:POWer:HREFerence.....	524
:TRACe<ch>[:POWer]:SWEep:PULSe:THReshold:POWer:LREFerence.....	524
:TRACe<ch>[:POWer]:SWEep:PULSe:THReshold:POWer:REFerence.....	524
:TRACe<ch>[:POWer]:SWEep:STATe.....	525
:TRIGger<hw>:FPSWeep:SOURce.....	721
:TRIGger<hw>:FSWeep:SOURce.....	720
:TRIGger<hw>:FSWeep[:IMMEDIATE].....	722
:TRIGger<hw>:LFFSweep.....	722
:TRIGger<hw>:LFFSweep:IMMEDIATE.....	722
:TRIGger<hw>:LFFSweep:SOURce.....	720
:TRIGger<hw>:PSWeep:SOURce.....	720
:TRIGger<hw>:PSWeep[:IMMEDIATE].....	722
:TRIGger<hw>[:SWEep]:SOURce.....	720
:TRIGger<hw>[:SWEep][:IMMEDIATE].....	722
:UNIT:ANGLE.....	723

:UNIT:POWer.....	723
[:SOURce]:CORRection:CSET:CATalog?.....	621
[:SOURce]:CORRection:CSET:DELeTe.....	622
[:SOURce]:INPut:TRIGger:SLOPe.....	632
[:SOURce]:LFOuTput:OFFSet.....	638
[:SOURce]:LFOuTput:VOLTagE.....	638
[:SOURce]:LFOuTput<ch>:BANDwidth?.....	635
[:SOURce]:LFOuTput<ch>:FREQuency.....	635
[:SOURce]:LFOuTput<ch>:INTernal:VOLTagE.....	637
[:SOURce]:LFOuTput<ch>:SOURce.....	638
[:SOURce]:LFOuTput<ch>:SOURce:PATH.....	638
[:SOURce]:LFOuTput<ch>[:STATe].....	637
[:SOURce]:PM<ch>[:DEViation].....	563
[:SOURce]:POWer:WIGNore.....	670
[:SOURce]:PULM[:INTernal][:TRAin]:TRIGger:IMMEdiate.....	565
[:SOURce]:ROSCillator:EXTernal:FREQuency.....	673
[:SOURce]:ROSCillator:EXTernal:FREQuency:VARiable.....	673
[:SOURce]:ROSCillator:EXTernal:MLRange?.....	674
[:SOURce]:ROSCillator:EXTernal:NSBandwidth?.....	674
[:SOURce]:ROSCillator:EXTernal:RFOFf[:STATe].....	673
[:SOURce]:ROSCillator:EXTernal:SBANDwidth.....	673
[:SOURce]:ROSCillator:INTernal:TUNing:SLOPe.....	672
[:SOURce]:ROSCillator:INTernal:TUNing[:STATe].....	672
[:SOURce]:ROSCillator:OUTPut:ALTErnate:FREQuency:MODE.....	675
[:SOURce]:ROSCillator:OUTPut:FREQuency:MODE.....	674
[:SOURce]:ROSCillator:PRESet.....	672
[:SOURce]:ROSCillator:SOURce.....	672
[:SOURce]:ROSCillator[:INTernal]:ADJJust:VALue.....	675
[:SOURce]:ROSCillator[:INTernal]:ADJJust[:STATe].....	676
[:SOURce<hw>]:ADF:COMid:CODE.....	582
[:SOURce<hw>]:ADF:COMid:DASH.....	582
[:SOURce<hw>]:ADF:COMid:DEPTH.....	583
[:SOURce<hw>]:ADF:COMid:DOT.....	583
[:SOURce<hw>]:ADF:COMid:FREQuency.....	583
[:SOURce<hw>]:ADF:COMid:LETTer.....	583
[:SOURce<hw>]:ADF:COMid:PERiod.....	584
[:SOURce<hw>]:ADF:COMid:SYMBol.....	584
[:SOURce<hw>]:ADF:COMid:TSCHema.....	584
[:SOURce<hw>]:ADF:COMid[:STATe].....	585
[:SOURce<hw>]:ADF:PRESet.....	579
[:SOURce<hw>]:ADF:SETTing:CATalog.....	580
[:SOURce<hw>]:ADF:SETTing:DELeTe.....	580
[:SOURce<hw>]:ADF:SETTing:LOAD.....	580
[:SOURce<hw>]:ADF:SETTing:STORe.....	581
[:SOURce<hw>]:ADF:STATe.....	581
[:SOURce<hw>]:AM:DEPTH:SUM.....	548
[:SOURce<hw>]:AM:DEViation:MODE.....	549
[:SOURce<hw>]:AM:MODE.....	548
[:SOURce<hw>]:AM:RATio.....	549
[:SOURce<hw>]:AM:TYPE.....	550

[[:SOURce<hw>]:AM<ch>:DEPTH:EXPonential.....	548
[[:SOURce<hw>]:AM<ch>:DEPTH:LINear.....	547
[[:SOURce<hw>]:AM<ch>:SENSitivity:EXPonential.....	549
[[:SOURce<hw>]:AM<ch>:SENSitivity[LINear].....	550
[[:SOURce<hw>]:AM<ch>:SOURce.....	547
[[:SOURce<hw>]:AM<ch>:STATe.....	546
[[:SOURce<hw>]:AM<ch>[:DEPTH].....	547
[[:SOURce<hw>]:CHIRp:BANDwidth.....	552
[[:SOURce<hw>]:CHIRp:COMPression:RATio?.....	552
[[:SOURce<hw>]:CHIRp:DIRection.....	552
[[:SOURce<hw>]:CHIRp:PULSe:PERiod.....	552
[[:SOURce<hw>]:CHIRp:PULSe:WIDTh.....	553
[[:SOURce<hw>]:CHIRp:STATe.....	553
[[:SOURce<hw>]:CHIRp:TRIGger:IMMediate.....	553
[[:SOURce<hw>]:CHIRp:TRIGger:MODE.....	553
[[:SOURce<hw>]:COMBined:FREQuency:STARt.....	685
[[:SOURce<hw>]:COMBined:FREQuency:STOP.....	685
[[:SOURce<hw>]:COMBined:POWer:STARt.....	685
[[:SOURce<hw>]:COMBined:POWer:STOP.....	686
[[:SOURce<hw>]:CORRection:CSET:DATA:FREQuency.....	619
[[:SOURce<hw>]:CORRection:CSET:DATA:FREQuency:POINts?.....	620
[[:SOURce<hw>]:CORRection:CSET:DATA:POWer.....	619
[[:SOURce<hw>]:CORRection:CSET:DATA:POWer:POINts?.....	620
[[:SOURce<hw>]:CORRection:CSET:DATA[:SENSor<ch>][:POWer]:SONCe.....	620
[[:SOURce<hw>]:CORRection:CSET:DATA[:SENSor<ch>][:POWer]:SONCe.....	621
[[:SOURce<hw>]:CORRection:CSET[:SELEct].....	620
[[:SOURce<hw>]:CORRection:DEXChange:AFILe:CATalog?.....	622
[[:SOURce<hw>]:CORRection:DEXChange:AFILe:EXTension.....	622
[[:SOURce<hw>]:CORRection:DEXChange:AFILe:SELEct.....	623
[[:SOURce<hw>]:CORRection:DEXChange:AFILe:SEParator:COLumn.....	623
[[:SOURce<hw>]:CORRection:DEXChange:AFILe:SEParator:DECimal.....	623
[[:SOURce<hw>]:CORRection:DEXChange:EXECute.....	623
[[:SOURce<hw>]:CORRection:DEXChange:MODE.....	624
[[:SOURce<hw>]:CORRection:DEXChange:SELEct.....	624
[[:SOURce<hw>]:CORRection:VALue?.....	620
[[:SOURce<hw>]:CORRection:ZERoing:STATe.....	621
[[:SOURce<hw>]:CORRection[:STATe].....	621
[[:SOURce<hw>]:FM:DEViation:MODE.....	557
[[:SOURce<hw>]:FM:DEViation:SUM.....	557
[[:SOURce<hw>]:FM:MODE.....	558
[[:SOURce<hw>]:FM:RATio.....	558
[[:SOURce<hw>]:FM:SENSitivity?.....	558
[[:SOURce<hw>]:FM<ch>:SOURce.....	556
[[:SOURce<hw>]:FM<ch>:STATe.....	556
[[:SOURce<hw>]:FM<ch>[:DEViation].....	556
[[:SOURce<hw>]:FREQuency:CENTer.....	629
[[:SOURce<hw>]:FREQuency:MANual.....	627
[[:SOURce<hw>]:FREQuency:MODE.....	625
[[:SOURce<hw>]:FREQuency:MULTiplier.....	628
[[:SOURce<hw>]:FREQuency:OFFSet.....	628



[[:SOURce<hw>]:FREQuency:PLL:MODE.....	631
[[:SOURce<hw>]:FREQuency:SPAN.....	629
[[:SOURce<hw>]:FREQuency:StARt.....	629
[[:SOURce<hw>]:FREQuency:StEP:MODE.....	630
[[:SOURce<hw>]:FREQuency:StEP[:INCRement].....	630
[[:SOURce<hw>]:FREQuency:StOP.....	630
[[:SOURce<hw>]:FREQuency[:CW FIXed].....	626
[[:SOURce<hw>]:FREQuency[:CW FIXed]:RCL.....	627
[[:SOURce<hw>]:ILS:GS GSLope:PRESet.....	592
[[:SOURce<hw>]:ILS:LOCalizer:COMid:CODE.....	593
[[:SOURce<hw>]:ILS:LOCalizer:COMid:DASH.....	593
[[:SOURce<hw>]:ILS:LOCalizer:COMid:DEPTh.....	594
[[:SOURce<hw>]:ILS:LOCalizer:COMid:DOT.....	594
[[:SOURce<hw>]:ILS:LOCalizer:COMid:FREQuency.....	594
[[:SOURce<hw>]:ILS:LOCalizer:COMid:LETTer.....	595
[[:SOURce<hw>]:ILS:LOCalizer:COMid:PERiod.....	595
[[:SOURce<hw>]:ILS:LOCalizer:COMid:SYMBol.....	595
[[:SOURce<hw>]:ILS:LOCalizer:COMid:TStHema.....	595
[[:SOURce<hw>]:ILS:LOCalizer:COMid[:StATE].....	596
[[:SOURce<hw>]:ILS:LOCalizer:DDM:COUPLing.....	596
[[:SOURce<hw>]:ILS:LOCalizer:DDM:CURRent.....	596
[[:SOURce<hw>]:ILS:LOCalizer:DDM:DIRection.....	597
[[:SOURce<hw>]:ILS:LOCalizer:DDM:LOGarithmic.....	597
[[:SOURce<hw>]:ILS:LOCalizer:DDM:PCT.....	598
[[:SOURce<hw>]:ILS:LOCalizer:DDM:POLarity.....	598
[[:SOURce<hw>]:ILS:LOCalizer:DDM:StEP.....	598
[[:SOURce<hw>]:ILS:LOCalizer:DDM[:DEPTh].....	599
[[:SOURce<hw>]:ILS:LOCalizer:FREQuency.....	599
[[:SOURce<hw>]:ILS:LOCalizer:FREQuency:MODE.....	599
[[:SOURce<hw>]:ILS:LOCalizer:FREQuency:SYNChronize[:StATE].....	581
[[:SOURce<hw>]:ILS:LOCalizer:FREQuency:SYNChronize[:StATE].....	600
[[:SOURce<hw>]:ILS:LOCalizer:ICAO:CHANnel.....	600
[[:SOURce<hw>]:ILS:LOCalizer:LLOBef[:FREQuency].....	600
[[:SOURce<hw>]:ILS:LOCalizer:MODE.....	601
[[:SOURce<hw>]:ILS:LOCalizer:PHASe.....	601
[[:SOURce<hw>]:ILS:LOCalizer:PRESet.....	601
[[:SOURce<hw>]:ILS:LOCalizer:RLOBef[:FREQuency].....	602
[[:SOURce<hw>]:ILS:LOCalizer:SDM.....	602
[[:SOURce<hw>]:ILS:LOCalizer:SOURce.....	602
[[:SOURce<hw>]:ILS:PRESet.....	580
[[:SOURce<hw>]:ILS:StETTING:CATalog?.....	580
[[:SOURce<hw>]:ILS:StETTING:DELete.....	580
[[:SOURce<hw>]:ILS:StETTING:LOAD.....	580
[[:SOURce<hw>]:ILS:StETTING:StORE.....	581
[[:SOURce<hw>]:ILS:StATE.....	581
[[:SOURce<hw>]:ILS:StYPE.....	586
[[:SOURce<hw>]:ILS[:GS GSLope]:DDM:COUPLing.....	587
[[:SOURce<hw>]:ILS[:GS GSLope]:DDM:CURRent.....	587
[[:SOURce<hw>]:ILS[:GS GSLope]:DDM:DIRection.....	587
[[:SOURce<hw>]:ILS[:GS GSLope]:DDM:LOGarithmic.....	588



[[:SOURce<hw>]:ILS[:GS GSLope]:DDM:PCT.....	588
[[:SOURce<hw>]:ILS[:GS GSLope]:DDM:POLarity.....	588
[[:SOURce<hw>]:ILS[:GS GSLope]:DDM:STEP.....	589
[[:SOURce<hw>]:ILS[:GS GSLope]:DDM[:DEPTh].....	589
[[:SOURce<hw>]:ILS[:GS GSLope]:FREQuency.....	589
[[:SOURce<hw>]:ILS[:GS GSLope]:FREQuency:MODE.....	590
[[:SOURce<hw>]:ILS[:GS GSLope]:FREQuency:SYNChronize[:STATe].....	581
[[:SOURce<hw>]:ILS[:GS GSLope]:FREQuency:SYNChronize[:STATe].....	590
[[:SOURce<hw>]:ILS[:GS GSLope]:ICAO:CHANnel.....	590
[[:SOURce<hw>]:ILS[:GS GSLope]:LLOBef[:FREQuency].....	591
[[:SOURce<hw>]:ILS[:GS GSLope]:MODE.....	591
[[:SOURce<hw>]:ILS[:GS GSLope]:PHASe.....	591
[[:SOURce<hw>]:ILS[:GS GSLope]:SDM.....	592
[[:SOURce<hw>]:ILS[:GS GSLope]:SOURce.....	592
[[:SOURce<hw>]:ILS[:GS GSLope]:ULOBef[:FREQuency].....	593
[[:SOURce<hw>]:INPut:MODext:COUPLing<ch>.....	631
[[:SOURce<hw>]:INPut:MODext:IMPedance<ch>.....	632
[[:SOURce<hw>]:LFOutput:FREQuency:MANual.....	636
[[:SOURce<hw>]:LFOutput:FREQuency:MODE.....	636
[[:SOURce<hw>]:LFOutput:FREQuency:STARt.....	637
[[:SOURce<hw>]:LFOutput:FREQuency:STOP.....	637
[[:SOURce<hw>]:LFOutput:SWEep[:FREQuency]:DWELl.....	642
[[:SOURce<hw>]:LFOutput:SWEep[:FREQuency]:EXECute.....	642
[[:SOURce<hw>]:LFOutput:SWEep[:FREQuency]:MODE.....	642
[[:SOURce<hw>]:LFOutput:SWEep[:FREQuency]:POINts.....	643
[[:SOURce<hw>]:LFOutput:SWEep[:FREQuency]:RETRace.....	643
[[:SOURce<hw>]:LFOutput:SWEep[:FREQuency]:RUNning?.....	643
[[:SOURce<hw>]:LFOutput:SWEep[:FREQuency]:SHAPE.....	644
[[:SOURce<hw>]:LFOutput:SWEep[:FREQuency]:SPACing.....	644
[[:SOURce<hw>]:LFOutput:SWEep[:FREQuency]:STEP:LOGarithmic.....	644
[[:SOURce<hw>]:LFOutput:SWEep[:FREQuency]:STEP[:LINear].....	645
[[:SOURce<hw>]:LFOutput<ch>:PERiod?.....	635
[[:SOURce<hw>]:LFOutput<ch>:SHAPE.....	639
[[:SOURce<hw>]:LFOutput<ch>:SHAPE:PULSe:DCYCLE.....	639
[[:SOURce<hw>]:LFOutput<ch>:SHAPE:PULSe:PERiod.....	639
[[:SOURce<hw>]:LFOutput<ch>:SHAPE:PULSe:WIDTh.....	640
[[:SOURce<hw>]:LFOutput<ch>:SHAPE:TRAPeZe:FALL.....	640
[[:SOURce<hw>]:LFOutput<ch>:SHAPE:TRAPeZe:HIGH.....	640
[[:SOURce<hw>]:LFOutput<ch>:SHAPE:TRAPeZe:PERiod.....	640
[[:SOURce<hw>]:LFOutput<ch>:SHAPE:TRAPeZe:RISE.....	641
[[:SOURce<hw>]:LFOutput<ch>:SHAPE:TRIangle:PERiod.....	641
[[:SOURce<hw>]:LFOutput<ch>:SHAPE:TRIangle:RISE.....	641
[[:SOURce<hw>]:LIST:CATalog?.....	653
[[:SOURce<hw>]:LIST:DELeTe.....	653
[[:SOURce<hw>]:LIST:DELeTe:ALL.....	654
[[:SOURce<hw>]:LIST:DEXChange:AFILe:CATalog?.....	655
[[:SOURce<hw>]:LIST:DEXChange:AFILe:EXTension.....	656
[[:SOURce<hw>]:LIST:DEXChange:AFILe:SElect.....	656
[[:SOURce<hw>]:LIST:DEXChange:AFILe:SEParator:COLumn.....	656
[[:SOURce<hw>]:LIST:DEXChange:AFILe:SEParator:DECimal.....	656

[[:SOURce<hw>]:LIST:DEXChange:EXECute.....	656
[[:SOURce<hw>]:LIST:DEXChange:MODE.....	657
[[:SOURce<hw>]:LIST:DEXChange:SElect.....	657
[[:SOURce<hw>]:LIST:DWELl.....	648
[[:SOURce<hw>]:LIST:DWELl:LIST.....	649
[[:SOURce<hw>]:LIST:DWELl:LIST:POINts?.....	649
[[:SOURce<hw>]:LIST:DWELl:MODE.....	648
[[:SOURce<hw>]:LIST:FREE?.....	654
[[:SOURce<hw>]:LIST:FREQuency.....	649
[[:SOURce<hw>]:LIST:FREQuency:POINts?.....	650
[[:SOURce<hw>]:LIST:INDEx.....	650
[[:SOURce<hw>]:LIST:INDEx:STARt.....	650
[[:SOURce<hw>]:LIST:INDEx:STOP.....	650
[[:SOURce<hw>]:LIST:MODE.....	651
[[:SOURce<hw>]:LIST:POWEr.....	651
[[:SOURce<hw>]:LIST:POWEr:POINts?.....	651
[[:SOURce<hw>]:LIST:RESEt.....	654
[[:SOURce<hw>]:LIST:RUNNing?.....	653
[[:SOURce<hw>]:LIST:SElect.....	655
[[:SOURce<hw>]:LIST:TRIGGer:EXECute.....	652
[[:SOURce<hw>]:LIST:TRIGGer:SOURce.....	652
[[:SOURce<hw>]:MODulation[:ALL][::STATe].....	543
[[:SOURce<hw>]:NOISe:BANdwidth BWIDth.....	658
[[:SOURce<hw>]:NOISe:BWIDth:STATe.....	658
[[:SOURce<hw>]:NOISe:DISTRibution.....	659
[[:SOURce<hw>]:NOISe:LEVel:RELative?.....	659
[[:SOURce<hw>]:NOISe:LEVel[:ABSolute]?.....	659
[[:SOURce<hw>]:PGENerator:OUTPut:POLarity.....	660
[[:SOURce<hw>]:PGENerator:OUTPut[::STATe].....	660
[[:SOURce<hw>]:PGENerator:STATe.....	661
[[:SOURce<hw>]:PHASe.....	661
[[:SOURce<hw>]:PHASe:REFerence.....	661
[[:SOURce<hw>]:PM:DEVIation:MODE.....	562
[[:SOURce<hw>]:PM:DEVIation:SUM.....	562
[[:SOURce<hw>]:PM:MODE.....	561
[[:SOURce<hw>]:PM:RATio.....	562
[[:SOURce<hw>]:PM:SENSitivity?.....	562
[[:SOURce<hw>]:PM<ch>:SOURce.....	561
[[:SOURce<hw>]:PM<ch>:STATe.....	560
[[:SOURce<hw>]:POWEr:ALC:DSENSitivity.....	663
[[:SOURce<hw>]:POWEr:ALC:MODE?.....	662
[[:SOURce<hw>]:POWEr:ALC:SONCe.....	664
[[:SOURce<hw>]:POWEr:ALC[::STATe].....	663
[[:SOURce<hw>]:POWEr:ATTenuation:PATTenuator.....	664
[[:SOURce<hw>]:POWEr:ATTenuation:RFOFF:MODE.....	664
[[:SOURce<hw>]:POWEr:EMF:STATe.....	664
[[:SOURce<hw>]:POWEr:LBEHaviour.....	665
[[:SOURce<hw>]:POWEr:LIMit[:AMPLitude].....	665
[[:SOURce<hw>]:POWEr:MANual.....	665
[[:SOURce<hw>]:POWEr:MODE.....	666

[[:SOURce<hw>]:POWer:POWer.....	666
[[:SOURce<hw>]:POWer:RANGe:LOWer?.....	670
[[:SOURce<hw>]:POWer:RANGe:MAX?.....	670
[[:SOURce<hw>]:POWer:RANGe:MIN?.....	670
[[:SOURce<hw>]:POWer:RANGe:UPPer?.....	670
[[:SOURce<hw>]:POWer:START.....	667
[[:SOURce<hw>]:POWer:STEP:MODE.....	667
[[:SOURce<hw>]:POWer:STEP[:INCRement].....	668
[[:SOURce<hw>]:POWer:STOP.....	667
[[:SOURce<hw>]:POWer[:LEVel][:IMMediate]:OFFSet.....	668
[[:SOURce<hw>]:POWer[:LEVel][:IMMediate]:RCL.....	669
[[:SOURce<hw>]:POWer[:LEVel][:IMMediate][:AMPLitude].....	669
[[:SOURce<hw>]:PULM:DELay.....	566
[[:SOURce<hw>]:PULM:DOUBle:DELay.....	566
[[:SOURce<hw>]:PULM:DOUBle:STATe.....	567
[[:SOURce<hw>]:PULM:DOUBle:WIDTh.....	567
[[:SOURce<hw>]:PULM:IMPedance.....	568
[[:SOURce<hw>]:PULM:MODE.....	565
[[:SOURce<hw>]:PULM:PERiod.....	565
[[:SOURce<hw>]:PULM:POLarity.....	568
[[:SOURce<hw>]:PULM:SOURce.....	567
[[:SOURce<hw>]:PULM:STATe.....	567
[[:SOURce<hw>]:PULM:THReshold.....	568
[[:SOURce<hw>]:PULM:TRAI:n:CATalog?.....	570
[[:SOURce<hw>]:PULM:TRAI:n:DELete.....	570
[[:SOURce<hw>]:PULM:TRAI:n:DEXChange:AFILe:CATalog?.....	573
[[:SOURce<hw>]:PULM:TRAI:n:DEXChange:AFILe:EXTenSion.....	572
[[:SOURce<hw>]:PULM:TRAI:n:DEXChange:AFILe:SELect.....	573
[[:SOURce<hw>]:PULM:TRAI:n:DEXChange:AFILe:SEPARator:COLumn.....	573
[[:SOURce<hw>]:PULM:TRAI:n:DEXChange:AFILe:SEPARator:DECimal.....	573
[[:SOURce<hw>]:PULM:TRAI:n:DEXChange:EXECute.....	574
[[:SOURce<hw>]:PULM:TRAI:n:DEXChange:MODE.....	572
[[:SOURce<hw>]:PULM:TRAI:n:DEXChange:SELect.....	574
[[:SOURce<hw>]:PULM:TRAI:n:OFFTime.....	570
[[:SOURce<hw>]:PULM:TRAI:n:OFFTime:POINts?.....	571
[[:SOURce<hw>]:PULM:TRAI:n:ONTime.....	570
[[:SOURce<hw>]:PULM:TRAI:n:ONTime:POINts?.....	571
[[:SOURce<hw>]:PULM:TRAI:n:REPetition.....	571
[[:SOURce<hw>]:PULM:TRAI:n:REPetition:POINts?.....	571
[[:SOURce<hw>]:PULM:TRAI:n:SELect.....	571
[[:SOURce<hw>]:PULM:TRIGger:MODE.....	565
[[:SOURce<hw>]:PULM:TTYPe.....	567
[[:SOURce<hw>]:PULM:WIDTh.....	566
[[:SOURce<hw>]:SWEep:COMBined:COUNT.....	686
[[:SOURce<hw>]:SWEep:COMBined:DWELl.....	686
[[:SOURce<hw>]:SWEep:COMBined:EXECute.....	686
[[:SOURce<hw>]:SWEep:COMBined:MODE.....	687
[[:SOURce<hw>]:SWEep:COMBined:RETRace.....	687
[[:SOURce<hw>]:SWEep:COMBined:SHAPE.....	688
[[:SOURce<hw>]:SWEep:GENeration.....	679

[:SOURce<hw>]:SWEep:MARKer:OUTPut:POLarity.....	688
[:SOURce<hw>]:SWEep:POWer:DWELI.....	679
[:SOURce<hw>]:SWEep:POWer:EXECute.....	683
[:SOURce<hw>]:SWEep:POWer:MODE.....	680
[:SOURce<hw>]:SWEep:POWer:POINts.....	680
[:SOURce<hw>]:SWEep:POWer:RETRace.....	683
[:SOURce<hw>]:SWEep:POWer:RUNNing?.....	684
[:SOURce<hw>]:SWEep:POWer:SHAPE.....	683
[:SOURce<hw>]:SWEep:POWer:SPACing:MODE?.....	680
[:SOURce<hw>]:SWEep:POWer:STEP[:LOGarithmic].....	681
[:SOURce<hw>]:SWEep:RESet[:ALL].....	688
[:SOURce<hw>]:SWEep[:FREQUency]:DWELI.....	681
[:SOURce<hw>]:SWEep[:FREQUency]:EXECute.....	683
[:SOURce<hw>]:SWEep[:FREQUency]:MARKer:ACTive.....	689
[:SOURce<hw>]:SWEep[:FREQUency]:MARKer<ch>:FREQUency.....	689
[:SOURce<hw>]:SWEep[:FREQUency]:MARKer<ch>:FState.....	689
[:SOURce<hw>]:SWEep[:FREQUency]:MODE.....	681
[:SOURce<hw>]:SWEep[:FREQUency]:POINts.....	682
[:SOURce<hw>]:SWEep[:FREQUency]:RETRace.....	683
[:SOURce<hw>]:SWEep[:FREQUency]:RUNNing?.....	684
[:SOURce<hw>]:SWEep[:FREQUency]:SHAPE.....	683
[:SOURce<hw>]:SWEep[:FREQUency]:SPACing.....	682
[:SOURce<hw>]:SWEep[:FREQUency]:STEP:LOGarithmic.....	684
[:SOURce<hw>]:SWEep[:FREQUency]:STEP[:LINear].....	684
[:SOURce<hw>]:SWEep[:FREQUency]:TIME.....	688
[:SOURce<hw>]:VOR:COMid:CODE.....	609
[:SOURce<hw>]:VOR:COMid:DASH.....	610
[:SOURce<hw>]:VOR:COMid:DEPTH.....	610
[:SOURce<hw>]:VOR:COMid:DOT.....	610
[:SOURce<hw>]:VOR:COMid:FREQUency.....	610
[:SOURce<hw>]:VOR:COMid:LETTer.....	611
[:SOURce<hw>]:VOR:COMid:PERiod.....	611
[:SOURce<hw>]:VOR:COMid:SYMBol.....	611
[:SOURce<hw>]:VOR:COMid:TSCHEMA.....	612
[:SOURce<hw>]:VOR:COMid[:STATe].....	612
[:SOURce<hw>]:VOR:FREQUency.....	612
[:SOURce<hw>]:VOR:FREQUency:MODE.....	613
[:SOURce<hw>]:VOR:ICAO:CHANnel.....	613
[:SOURce<hw>]:VOR:MODE.....	614
[:SOURce<hw>]:VOR:PRESet.....	580
[:SOURce<hw>]:VOR:REFerence[:DEViation].....	615
[:SOURce<hw>]:VOR:SETTing:CATalog?.....	580
[:SOURce<hw>]:VOR:SETTing:DELeTe.....	580
[:SOURce<hw>]:VOR:SETTing:LOAD.....	580
[:SOURce<hw>]:VOR:SETTing:STORe.....	581
[:SOURce<hw>]:VOR:SOURce.....	608
[:SOURce<hw>]:VOR:STATe.....	581
[:SOURce<hw>]:VOR:SUBCarrier:DEPTH.....	615
[:SOURce<hw>]:VOR:SUBCarrier[:FREQUency].....	615
[:SOURce<hw>]:VOR:VAR:FREQUency.....	616

[SOURce<hw>]:VOR:VAR[:DEPTh].....	616
[SOURce<hw>]:VOR[:BANGle].....	608
[SOURce<hw>]:VOR[:BANGle]:DIRection.....	609
[SOURce<hw>][:ILS]:MBEacon:COMid:CODE.....	603
[SOURce<hw>][:ILS]:MBEacon:COMid:DASH.....	603
[SOURce<hw>][:ILS]:MBEacon:COMid:DEPTH.....	603
[SOURce<hw>][:ILS]:MBEacon:COMid:DOT.....	604
[SOURce<hw>][:ILS]:MBEacon:COMid:FREQuency.....	604
[SOURce<hw>][:ILS]:MBEacon:COMid:LETTer.....	604
[SOURce<hw>][:ILS]:MBEacon:COMid:PERiod.....	605
[SOURce<hw>][:ILS]:MBEacon:COMid:SYMBol.....	605
[SOURce<hw>][:ILS]:MBEacon:COMid:TSCHEMA.....	605
[SOURce<hw>][:ILS]:MBEacon:COMid[:STATe].....	606
[SOURce<hw>][:ILS]:MBEacon:FREQuency.....	606
[SOURce<hw>][:ILS]:MBEacon:FREQuency:MODE.....	606
[SOURce<hw>][:ILS]:MBEacon:MARKer:FREQuency.....	606
[SOURce<hw>][:ILS]:MBEacon:PRESet.....	607
[SOURce<hw>][:ILS]:MBEacon[:MARKer]:DEPTH.....	607
[SOURce<hw>][:ILS]:MBEacon[:MARKer]:PULSed.....	607
*CLS.....	436
*ESE.....	436
*ESR?.....	436
*IDN?.....	436
*IST?.....	437
*OPC.....	437
*OPT?.....	437
*PRE.....	437
*PSC.....	437
*RCL.....	438
*RST.....	438
*SAV.....	438
*SRE.....	439
*STB?.....	439
*TRG.....	439
*TST?.....	439
*WAI.....	439
<subsystem>:FREQuency:SYNChronize:STATe.....	581
<subsystem>:PRESet.....	579
<subsystem>:SETTing:CATalog.....	580
<subsystem>:SETTing:DELeTe.....	580
<subsystem>:SETTing:LOAD.....	580
<subsystem>:SETTing:STORe.....	581
<subsystem>:STATe.....	581

# Index

## Symbols

*OPC .....	761
*OPC? .....	761
*RST .....	772
*WAI .....	761
/var/user directory .....	441
/var/volatile directory .....	441
&GTL .....	413
&LLO .....	413
&NREN .....	413
9.91E37	
Remote control .....	760
50 - Extern reference out of range or disconnected .....	726
140 - This modulation forces other modulations off .....	726
180 - Adjustment failed .....	726
182 - Adjustment data missing .....	726
183 - Adjustment data invalid .....	726
200 - Cannot access hardware .....	726
201 - Hardware revision out of date .....	726
202 - Cannot access the EEPROM .....	726
203 - Invalid EEPROM data .....	726
204 - river initialization failed .....	726
241 - No current list .....	726
242 - Unknown list type specified .....	726
460 - Cannot open the file .....	726
461 - Cannot write file .....	727
462 - Cannot read file .....	727
463 - Filename missing .....	727
464 - Invalid filename extension .....	727
465 - File contains invalid data .....	727

## A

About	
Attenuator .....	211
Internal adjustments .....	739
Power-On/EMF .....	340
Reference oscillator .....	288
Selftests .....	739
UCOR .....	216, 217
Accept	
Security settings .....	363
Active connections	
Remote access .....	389
Active elements .....	59
Add LAN sensor	
NRP sensor mapping .....	232
Add sensor	
NRP sensor mapping .....	232
Add USBTMC sensor	
NRP sensor mapping .....	232
Add, change, delete	
User key action .....	347
Adjust	
Display and keyboard .....	338
Display settings .....	337
Keyboard settings .....	337
Adjustment frequency	
Reference oscillator .....	294
Adjustments	
All .....	745
Continue .....	746

Information .....	746
Last full adjustment .....	745
Settings .....	745
Advanced configuration	
LXI .....	396
ALC	
Detector sensitivity .....	216
Settings .....	215
State .....	216
All packages	
Secure update policy .....	356
Alphanumeric parameters .....	62
AM .....	80
Deviation mode .....	91
Overview .....	123
Ratio .....	92
Subsystem .....	544
Total deviation .....	91
Amplitude	
ILS glide slope .....	147
ILS localizer .....	153
Amplitude modulation .....	89
Depth .....	91
Deviation mode .....	91
Mode .....	90
Ratio .....	92
Sensitivity .....	91
Subsystem .....	544
Type .....	90
Analog modulation	
Options .....	80
Overview .....	121
Signal source .....	80
Annotation	
Disable amplitude display .....	359
Disable frequency display .....	359
Disable level .....	359
Aperture time	
Power sensors .....	239
Application cards .....	22
Application notes .....	22
ATN .....	779
Attention .....	779
Attenuator	
About .....	211
RF signal .....	211
Settings .....	212
Attenuator settings	
Level range .....	213
Mode .....	213
RF OFF mode .....	213
Step Attenuator below 20 GHz .....	213
Auto once	
Power sensors .....	239
Power viewer .....	239
Automatic level control	
Detector sensitivity .....	216
Readjust internal switch position .....	78
Settings .....	215
State .....	216
Automation .....	371
Autonegotiation	
Failed .....	729

- Avahi
  - LAN services ..... 362
- Average
  - Power analysis ..... 252
- Average level
  - Power viewer ..... 236
- Avionics standards
  - Overview ..... 126
- B**
- Bandwidth
  - Chirp modulation ..... 95
  - Modulation input ..... 117
  - Noise generator ..... 118
- Basics
  - Editor ..... 106, 207, 223
  - Export list files ..... 107, 226
  - Fill with sensor list files ..... 224
  - Import list files ..... 107, 226
- Baud rate
  - RS232 interface ..... 387
- Bearing angle
  - VOR ..... 137
- Bench top, placing ..... 28
- Block data ..... 757
- Boolean parameters ..... 756
- Brackets ..... 757
- Brochures ..... 21
- Browser settings
  - LXI ..... 394
- Bytes order
  - Definition ..... 467
- C**
- CALibration subsystem ..... 452
- Carrier frequency
  - ILS glide slope ..... 144
  - ILS localizer ..... 150
  - ILS marker beacons ..... 159
  - VOR ..... 134
- Carrier frequency mode
  - ILS glide slope ..... 144
  - ILS localizer ..... 150
  - ILS marker beacons ..... 159
  - VOR ..... 134
- Carrying the instrument ..... 27
- Case-sensitivity
  - SCPI ..... 753
- Central storage
  - Accessing ..... 330
- Change
  - GPIO address ..... 404, 411
- Change password
  - Setup (security) ..... 365
- Change user password
  - Setup (security) ..... 365
- Check front panel
  - Key panel test ..... 743
  - Performing ..... 742
  - Settings ..... 742
- Check touch panel
  - Touchscreen test ..... 743
- Checking the instrument ..... 27
- Chirp
  - Modulation ..... 94
- CHIRp
  - Subsystem ..... 550
- Chirp modulation ..... 80, 92
  - Bandwidth ..... 95
  - Compression ratio ..... 96
  - Direction ..... 95
  - Gated signal ..... 96
  - Pulse external settings ..... 97
  - Pulse period ..... 95
  - Pulse width ..... 96
  - Remote control commands ..... 550
  - Settings ..... 94
  - Single trigger ..... 96
  - State ..... 94
  - Subsystem ..... 550
  - Trigger mode ..... 96
  - Trigger settings ..... 97
- Cleaning ..... 739
- Clear
  - NRP sensor mapping ..... 232
  - RF output protection ..... 214
  - User menu ..... 343
- Clear history
  - Undo/Redo ..... 369
- Clear status
  - Remote ..... 436
- Clk Syn connector ..... 43, 46
- Clock
  - Amplitude ..... 300
  - DC offset ..... 301
  - Frequency ..... 300
  - Phase, reset ..... 301
  - Phase, set ..... 301
  - Shape ..... 299
- Clock synthesis ..... 454
- Clock synthesis inverted output ..... 298
- Clock synthesis output ..... 298
- Close
  - Show SCPI command ..... 417
- Colon ..... 757
- Color
  - Power analysis ..... 247
- COM/ID
  - ILS localizer ..... 156
  - ILS marker beacons ..... 161
  - VOR ..... 138
- COM/ID code
  - ADF ..... 166
  - ILS localizer ..... 157
  - ILS marker beacons ..... 162
  - VOR ..... 139
- COM/ID dash length
  - ADF ..... 167
  - ILS localizer ..... 158
  - ILS marker beacons ..... 163
  - VOR ..... 139
- COM/ID depth
  - ADF ..... 167
  - ILS localizer ..... 157
  - ILS marker beacons ..... 162
  - VOR ..... 139
- COM/ID dot length
  - ADF ..... 167
  - ILS localizer ..... 158
  - ILS marker beacons ..... 163
  - VOR ..... 139



- COM/ID frequency
  - ADF ..... 167
  - ILS localizer ..... 157
  - ILS marker beacons ..... 162
  - VOR ..... 139
- COM/ID letter space
  - ADF ..... 168
  - ILS localizer ..... 158
  - VOR ..... 140
- COM/ID letterspace
  - ILS marker beacons ..... 163
- COM/ID period
  - ILS localizer ..... 157, 167
  - ILS marker beacons ..... 162
  - VOR ..... 139
- COM/ID settings
  - ADF ..... 166
- COM/ID state
  - ADF ..... 166
  - ILS localizer ..... 157
  - ILS marker beacons ..... 162
  - VOR ..... 138
- COM/ID symbol space
  - ADF ..... 167
  - ILS localizer ..... 158
  - ILS marker beacons ..... 163
  - VOR ..... 140
- COM/ID time schema
  - ADF ..... 167
  - ILS localizer ..... 158
  - ILS marker beacons ..... 162
  - VOR ..... 139
- Combined RF frequency / level sweep
  - Step count ..... 195
- Combined sweep
  - Spacing ..... 190, 193
- Comma ..... 757
- Command sequence
  - recommendation ..... 772
  - Remote ..... 439
- Commands ..... 751
  - Brackets ..... 757
  - Colon ..... 757
  - Comma ..... 757
  - Command line structure ..... 759
  - Common ..... 751
  - Double dagger ..... 757
  - Instrument control ..... 751
  - Overlapping ..... 760
  - Question mark ..... 757
  - Quotation mark ..... 757
  - SCPI confirmed ..... 751
  - Sequential ..... 760
  - Syntax elements ..... 757
  - Vertical stroke ..... 757
  - White space ..... 757
- Commands of all settings
  - SCPI list ..... 313
- Common commands
  - Syntax ..... 753
- Component
  - ILS ..... 142
- Compression ratio
  - Chirp modulation ..... 96
- Computer name
  - Changing ..... 401
  - Syntax ..... 401
  - Use instead of IP address ..... 401
- CONDition ..... 766
- Configuration
  - Restoring ..... 314
  - Restoring instrument settings ..... 311
- Configure
  - Power analysis ..... 245
- Configure diagram
  - Power analysis ..... 257
- Configure gate mode
  - Power analysis ..... 268
- Configure measurement
  - Power analysis ..... 250
- Configure sensor
  - Power analysis ..... 254
- Configure time mode
  - Power analysis ..... 259
- Configuring LAN services ..... 361
- Confirm unsigned
  - Secure update policy ..... 356
- Confirm user password
  - Setup (security) ..... 364, 365
- Connecting
  - Keyboard ..... 32
  - LAN ..... 31
  - Memory stick ..... 32
  - Mouse ..... 32
  - Power ..... 31
  - To Ref In/Ref Out ..... 34
  - To RF ..... 32
  - USB devices ..... 32
- Connection fault
  - 169.254.\*.\* ..... 729
- Connector
  - AC power supply ..... 47
  - Clk Syn N ..... 43, 46
  - EFC ..... 46
  - Ext ..... 43, 47
  - GPIO ..... 45
  - IEC/IEEE ..... 45
  - Inst Trig ..... 46
  - LAN ..... 45
  - LF ..... 43, 47
  - Marker User1 ..... 46
  - Pulse Ext ..... 43, 46
  - Pulse Sync ..... 43, 47
  - Pulse Video ..... 43, 46
  - Ref In ..... 46
  - Ref Out ..... 46
  - RF ..... 42, 47
  - Sensor ..... 42
  - Signal Valid ..... 46
  - Stop ..... 46
  - USB ..... 41, 45
  - USB In ..... 45
  - V/GHz X-Axis ..... 45
  - Z-Axis ..... 45
- Connectors
  - RF signal ..... 69
- Context-sensitive menu ..... 59
- Continue
  - Internal adjustments ..... 746
- Control bus ..... 779



- Copy
  - Instrument settings ..... 320
  - Several files ..... 318, 327, 328
  - Show SCPI command ..... 417
- Counter ..... 731
- Coupling mode
  - AM, FM, PhiM ..... 117
  - External modulation input ..... 117
- Create
  - New directory ..... 320
- Current frequency
  - Sweep ..... 187
- Current index
  - List mode ..... 200
- Current level
  - Sweep ..... 187
- Customer support ..... 736
- Cut
  - Instrument settings ..... 320
- CW
  - Frequency ..... 72
- CW mode
  - Output level ..... 75
- CW signal
  - Settings ..... 67
- D**
- Data entry ..... 61
- Data format
  - Definition ..... 468
- Data list
  - Access ..... 315
  - How to access ..... 443
  - Select, edit, new ..... 317
- Data sheets ..... 21
- Data valid ..... 779
- Datasheet
  - LXI ..... 399
- Date ..... 740
- DAV ..... 779
- DDM - SDM coupling
  - ILS glide slope ..... 149
  - ILS localizer ..... 155
- DDM current
  - ILS glide slope ..... 148
  - ILS localizer ..... 155
- DDM depth
  - ILS glide slope ..... 148
  - ILS localizer ..... 155
- DDM logarithmic
  - ILS glide slope ..... 148
  - ILS localizer ..... 156
- DDM percent
  - ILS glide slope ..... 149
  - ILS localizer ..... 156
- DDM polarity
  - ILS localizer ..... 153
- DDM step
  - ILS glide slope ..... 148
  - ILS localizer ..... 155
- Deactivate RF output ..... 290
- Deactivated licenses ..... 351
- Declassification ..... 358
- DEF ..... 756
- Default directory
  - Mass memory ..... 441
  - User data ..... 303, 442
- Default settings ..... 133, 142, 165
- Default values
  - Remote ..... 438
- Define
  - User key action ..... 347
- Delay
  - Double pulse (PULM) ..... 103
  - PULM ..... 103
- Delete
  - Instrument settings ..... 320
  - List mode file ..... 202
- Delete instrument settings ..... 449
- Delta phase
  - RF frequency ..... 79
- Depth of modulation polarity
  - ILS glide slope ..... 146
- Detector sensitivity
  - Automatic level control ..... 216
- Deviation
  - Fixed total deviation ..... 87, 88
  - PhiM ..... 88
- Deviation mode
  - AM ..... 91
  - Amplitude modulation ..... 91
  - FM ..... 87
  - Frequency modulation ..... 87
  - Phase modulation ..... 88
  - PhiM ..... 88
- Device ID ..... 350, 713
  - NRP sensor mapping ..... 232
- Device reset ..... 440
- Device-specific commands ..... 751
- Device-specific error messages ..... 725
- DHCP ..... 400
- Dialog boxes ..... 60
- Direction
  - Chirp modulation ..... 95
  - VOR ..... 137
- Directory
  - Temporary data ..... 441
  - User data ..... 441
- Disable
  - Frequency display ..... 359
  - Level display ..... 359
- Display
  - Active elements ..... 59
  - Brightness ..... 339
  - Context-sensitive menu ..... 59
  - Info line ..... 59
  - Information ..... 57
  - Keyboard layout ..... 339
  - Lock ..... 359
  - On-screen keypad ..... 59
  - Overview ..... 38
  - Power sensors ..... 237
  - SCPI list ..... 417
  - Screen saver ..... 339
  - Settings ..... 338
  - Setup ..... 338
  - Status bar ..... 57
  - Tab labels ..... 59
  - Taskbar ..... 58
  - Tile diagram ..... 57
  - Wait time (screen saver) ..... 339

- Display correction value
  - UCOR ..... 220
- DISPlay subsystem ..... 462
- Disposal ..... 739
- Distribution
  - Noise generator ..... 118
- DNS server ..... 385
- DNS suffix ..... 385
- Documentation overview ..... 20
- Double dagger ..... 757
- Double pulse delay
  - PULM ..... 103
- Double pulse width
  - PULM ..... 103
- DOWN ..... 756
- Down frequency
  - ILS glide slope ..... 146
- Downgrade information ..... 733
  - Factory version ..... 733
  - Min. version ..... 733
- Dwell time
  - Sweep ..... 190
- Dwell time mode
  - List mode ..... 201
- E**
- Edit
  - Editor ..... 106, 208, 223
  - List mode data ..... 203
  - UCOR data ..... 221
- Editor
  - Basics ..... 106, 207, 223
  - Edit ..... 106, 208, 223
  - Fill with sensor ..... 208, 223
  - Goto ..... 106, 207, 223
  - Save ..... 106, 208, 223
  - Save as ..... 106, 208, 223
- EFC
  - Activate ..... 292
  - Sensitivity ..... 292
- EMF display
  - RF level ..... 340
- Emulating front panel keys ..... 65
- Emulation
  - IDN string ..... 389
  - Language ..... 388
  - Mode ..... 388
  - Set IDN and OPT to default ..... 388
- Enable
  - LAN interface ..... 362
- ENABLE ..... 766
- Enable registers
  - Remote ..... 437
- Enter license key ..... 351
- Enter password
  - Setup (security) ..... 363
- EOI ..... 779
- Error log ..... 735
- Error messages ..... 727
  - Adjustment data invalid (183) ..... 726
  - Adjustment data missing (182) ..... 726
  - Adjustment failed (180) ..... 726
  - Cannot access hardware (200) ..... 726
  - Cannot access the EEPROM (202) ..... 726
  - Cannot open file (460) ..... 726
  - Cannot read file (462) ..... 727
  - Cannot write file (461) ..... 727
  - Driver initialization failed (204) ..... 726
  - Extern reference out of range or disconnected (50) . 726
  - File contains invalid data (465) ..... 727
  - Filename missing (463) ..... 727
  - Hardware revision out of date (201) ..... 726
  - Invalid EEPROM data (203) ..... 726
  - Invalid filename extension (464) ..... 727
  - No current list (241) ..... 726
  - This modulation forces other modulations off (140) .. 726
  - Unknown list type specified (242) ..... 726
- Error Messages ..... 724
  - device-specific ..... 725
  - SCPI ..... 725
- Error queue ..... 767
- Error queue query ..... 693, 694
- Error queues
  - recommendations ..... 772
- ESE (event status enable register ) ..... 768
- ESR ..... 765
- ESR (event status register) ..... 768
- EVENT ..... 766
- Event status enable register (ESE) ..... 768
  - Remote ..... 436
- Event status register (ESR) ..... 768
  - Remote ..... 436
- Exchanging RF port ..... 749
- Exclude frequency ..... 313
- Exclude level ..... 314
- Execute
  - Single sweep ..... 191
  - Trigger (list mode) ..... 202
- Expiration date of option ..... 733
- Export
  - Execute ..... 109, 205, 228
  - SCPI ..... 317
  - SCPI export ..... 419
  - SCPI list ..... 418
  - SCPI settings ..... 418
- Export deactivation response ..... 351
- Export license key ..... 351
- Export list files
  - Basics ..... 107, 226
- Express level in
  - Volts ..... 662
- Ext AM
  - ILS glide slope ..... 144
  - ILS localizer ..... 151
  - VOR ..... 135
- External frequency
  - Reference oscillator ..... 290
- F**
- Factory
  - Preset ..... 308
- Factory preset
  - Change GPIB address ..... 404
  - GPIB address ..... 411
- Factory version
  - Firmware ..... 733
- File
  - SCPI export ..... 419
- File catalog
  - List mode ..... 202
- File handling ..... 304
- File list ..... 446

- File manager ..... 318
- File name ..... 332
- File select
  - Dialog ..... 315
- File server
  - Data exchange ..... 330
- File sharing ..... 325
- File storage location ..... 441
- File system ..... 302
  - Accessing ..... 325
- File transfer ..... 304
  - From file server ..... 330
  - FTP/SAMBA ..... 371
  - How to ..... 325
- File type selection ..... 320
- Filename
  - Pulse graph ..... 110
- Files
  - User data ..... 302
- Fill
  - User correction data ..... 106, 208, 223
- Fill table
  - Automatically ..... 106, 208, 223
  - UCOR ..... 221
- Fill with sensor
  - Basics ..... 224
  - Editor ..... 208, 223
- Filter
  - Power sensors ..... 238
- Filter length
  - Auto ..... 239
  - User-defiend ..... 239
- Finding out the default directory ..... 303, 442
- Firmware
  - Factory version ..... 733
  - Min. version ..... 733
  - Version ..... 732
- Fixed
  - Frequency ..... 72
- Floating licenses ..... 733
- Fly
  - ILS glide slope ..... 148
  - ILS localizer ..... 154
- FM
  - Deviation ..... 86
  - Deviation mode ..... 87
  - Ratio ..... 87
  - Subsystem ..... 554
  - Total deviation ..... 87
- Format
  - SCPI Export ..... 418
- FORMat subsystem ..... 467
- FPGA/μC
  - Check for updates ..... 749
  - Check for updates of external ..... 749
  - Shut down after update internal ..... 749
  - Update installation internal assembly ..... 749
  - Update table ..... 749
- Frequency
  - Annotation disable ..... 359
  - CW, fixed ..... 72
  - LF generator ..... 115
  - LF sweep ..... 115
  - Multiplier ..... 73
  - Offset ..... 73
  - Power sensors ..... 238
  - RF signal ..... 71
  - UCOR ..... 221
- Frequency marker
  - Activate ..... 198
  - Boost marker x ..... 199
  - Duration ..... 199
  - Polarity ..... 199
  - State ..... 198
- Frequency modulation ..... 86
  - Deviation mode ..... 87
  - Ratio ..... 87
  - Subsystem ..... 554
- Frequency sweep
  - Sweep type ..... 186, 197
  - V/GHz ..... 196
  - X-Axis ..... 196
- Frequency, internal
  - AM ..... 115
  - FM ..... 115
- Front panel
  - Checking ..... 742
- Front panel test
  - Performing ..... 742
- Front panel tour ..... 37
- ftp
  - How to access the instrument ..... 325
- FTP
  - LAN services ..... 362
- Function keys
  - Overview ..... 39
- G**
- Gated signal
  - Chirp modulation ..... 96
- Gateway ..... 385
- General
  - ILS glide slope ..... 143
  - ILS localizer ..... 150
  - ILS marker beacons ..... 159
  - VOR ..... 132
- General configuration of instrument ..... 337
- General instrument functions
  - User key ..... 342
  - User menu ..... 342
- General instrument settings ..... 337
- General settings
  - ADF ..... 164
  - ILS ..... 140
- Generating an unmodulated signal ..... 67
- Getting started ..... 21
- Global dwell time
  - List mode ..... 201
- Goto
  - Editor ..... 106, 207, 223
- GPIB
  - Bus address ..... 386
  - Change address ..... 404, 411
  - Characteristics ..... 377
  - Set up remote control ..... 411
- GPIB address ..... 386
  - Factory preset ..... 411
- GUI
  - Setting ..... 341
- GUI update
  - Setup ..... 337

**H**

Hard copy	
Create, how to	335
File format	332, 333
Print, how to	335
Hardcopy	331
Options	332
Help	21, 63
HiSLIP	
Protocol	376
Resource string	374
History	
Undo/Redo	369
Host name	
NRP sensor mapping	232
see computer name	401
Hostname	384
LXI	393
see computer name	401
How to	
Change the default directory	443
Query hardware options	733
Query RF assembly	734
Use an absolute file path	443
User key	348
User menu	344
HTTP	
LAN services	362

**I**

ICAO channel	
ILS	144
ILS localizer	151
VOR	134
Identification	
Emulation mode	388
Remote	436
IDN string	
Emulation mode	389
IFC	779
ILS	
Glide Slope	143
Localizer	149
Marker beacons	158
ILS component	142
Impedance	
External modulation source	117
Import	
Execute	109, 205, 228
SCPI	317
Import license key	351
Import list files	
Basics	107, 226
Import/Export	
Lists	203
Select file	109, 204, 205, 227, 228
Inactive licenses	351
Index	
List mode	200
INF	756
Info line	59, 727
Information	
Internal adjustments	746

**Input**

Impedance external modulations	117
Pulse Ext	92
Pulse polarity	111
Pulse threshold	111
Trigger impedance	111
Input connector	43, 46, 47
Input connectors	
Stop	46
Installed assembly	731
Instrument	
Carrying	27
Checking	27
Lifting	27
Operating site	27, 28
Unpacking	27
Instrument control	55
Instrument emulations	382, 388
Instrument help	21
Instrument messages	751
Instrument security procedures	21
Instrument settings	
Recall	438, 449
Save	438, 451
Instrument tour	36
Interface	
functions (GPIB bus)	780
Interface clear	779
Interface messages	751, 752
Interfaces	
GPIB	377
USB	377
Internal adjustments	
About	739
Interrupt	770
Invalid results	
Remote control	760
IP address	374
Changing	400
Dynamic	384
LXI	393
Not recognized	729
NRP sensor mapping	232
Zeroconf	384
IP address Mode	384
IP configuration	
LXI	395
IST	765
IST flag	
Remote	437

**K**

Key	
★ (User)	41
Access on a remote computer	65
Arrow	40
Backspace	40
Down	40
Emulation	65
Enter	40
Esc	40
Freq	39
Help	39
Home	41
Left	40
Level	39

- Local ..... 39
- Mod on/off ..... 39, 82
- Next window ..... 41
- On/Off ..... 41
- On/Standby ..... 39
- Preset ..... 39
- Resize window ..... 41
- RF on/off ..... 39
- Right ..... 40
- Setup ..... 39
- Up ..... 40
- Key panel test
  - Check front panel ..... 743
- Keyboard
  - On-screen ..... 61
  - Setting ..... 341
  - Settings ..... 338
  - Setup ..... 338
  - Subsystem ..... 473
  - Usage ..... 56
- Keypad
  - On-screen ..... 61
  - Overview ..... 39
- Keywords
  - see Mnemonics ..... 752
- L**
- LAN
  - Connecting ..... 31
  - Interface ..... 374
  - IP address ..... 374
  - Main services ..... 362
  - Reset ..... 393
  - Samba services ..... 362
  - Services ..... 361
  - VXI protocol ..... 376
- LAN configuration ..... 399
- LXI ..... 395
- LAN interface
  - Avahi ..... 362
  - Enable ..... 362
  - FTP ..... 362
  - HTTP ..... 362
  - LAN over SCPI ..... 362
  - SMB (Samba) ..... 362
  - SSH ..... 362
  - VNC ..... 362
- LAN status
  - LXI ..... 393
- Landing systems
  - Overview ..... 126
- Language
  - Emulation ..... 388
- Last factory calibration ..... 732
- Last full adjustment
  - Internal adjustments ..... 745
- Layout
  - Keyboard ..... 339
- Left frequency
  - ILS localizer ..... 153
- Left/Right phase
  - ILS localizer ..... 153
- Level
  - Annotation disable ..... 359
  - Behavior (RF) ..... 76, 195
  - Noise generator ..... 121
- Level default unit
  - Change ..... 662
- Level in SCPI in V ..... 662
- Level limit ..... 76
- Level offset
  - Power sensors ..... 238
  - RF level ..... 76
  - State (power sensors) ..... 238
- Level range
  - Attenuator settings ..... 213
- Level settings
  - On start-up ..... 340
- LF frequency sweep
  - State ..... 113, 187
- LF generator
  - Shape ..... 113
- LF Out
  - Overview ..... 122
- LF output ..... 119
- Load impedance ..... 120
- Offset ..... 120
- Period ..... 115
- Pulse duty cycle ..... 115
- Pulse width ..... 115
- Shape ..... 113
- Source ..... 120, 123
- Sweep reset ..... 191
- Trapezoid high ..... 116
- Trapezoid rise, fall ..... 116
- Triangle rise ..... 116
- Voltage ..... 120
- LF sweep
  - Frequency ..... 115
- License for software option ..... 733
- Infos ..... 733
- Lifting the instrument ..... 27
- Limit
  - RF level ..... 76
- List
  - Define ..... 203
  - Range ..... 203
  - State ..... 200
  - Values, defining ..... 207, 222
- List file
  - Catalog ..... 202
- List mode
  - Create list automatically ..... 106, 208, 223
  - Current index ..... 200
  - Dwell time mode ..... 201
  - Edit ..... 203
  - Execute trigger ..... 202
  - Export user data ..... 109, 205, 228
  - File settings, import/export ..... 108, 204, 227
  - Global dwell time ..... 201
  - Import/export ..... 108, 203, 204, 227
  - Load from file ..... 109, 204, 227
  - Load user data ..... 203
  - Reset ..... 202
  - Select file ..... 202
  - Settings ..... 199
  - State ..... 200
  - Trigger execute ..... 202
  - Trigger source ..... 201
- Load
  - Impedance ..... 120
  - See recall ..... 311
- Load instrument settings ..... 438, 449

- Loading
  - Trying out ..... 53
- Local to remote switch over ..... 413
- Lock
  - Display ..... 359
- LSB/MSB order
  - Definition ..... 467
- LXI
  - Advanced configuration ..... 396
  - Browser settings ..... 394
  - Configuration ..... 430
  - Datasheet ..... 399
  - Hostname ..... 393
  - IP address ..... 393
  - IP configuration ..... 395
  - LAN configuration ..... 395
  - LAN status ..... 393
  - MAC address ..... 393
  - Ping ..... 397
  - Remote trace (SCPI) ..... 397
  - Reset (LCI) ..... 393
  - Status settings ..... 392
  - Traicing ..... 413
- LXI settings ..... 392
- M**
- Mac address ..... 385
- MAC address
  - LXI ..... 393
- Maintenance ..... 739
- Malfunctions
  - reacting ..... 772
- Manual interaction ..... 56
- Map network share
  - Settings ..... 320
- Mapping network drives/folders
  - How to ..... 322
- Mark frequency
  - Sweep ..... 198
- Marker
  - Power analysis ..... 245
- Marker depth
  - ILS marker beacons ..... 160
- Marker frequency
  - ILS marker beacons ..... 160
- Marker User1 ..... 46
- Mass storage location ..... 441
- Max
  - RF level sweep ..... 196
- MAX ..... 756
- Maximal deviation
  - Frequency modulation ..... 86
  - PhiM ..... 88
- Measurement window
  - Power analysis ..... 244
- Messages
  - Commands ..... 751
  - Instrument ..... 751
  - Instrument responses ..... 752
  - Interface ..... 751
- Min
  - RF level sweep ..... 196
- MIN ..... 756
- Min. version
  - Firmware ..... 733
- Min/max Y scale
  - Power analysis ..... 257
- Minimum locking range ..... 291
- Mnemonics ..... 752
- Optional ..... 754
- Mode
  - AM ..... 90
  - Attenuator settings ..... 213
  - Emulation ..... 388
  - Frequency modulation ..... 87
  - IP address ..... 384
  - List ..... 201
  - PhiM ..... 89
  - PULM ..... 99
  - Pulse modulation ..... 99
  - Sweep ..... 187
  - User variation ..... 73, 78
  - VOR ..... 136
- Modulation
  - AM ..... 83
  - Analog ..... 80
  - Bandwidth, external input ..... 117
  - Chirp modulation ..... 92, 94
  - Chirp modulation settings ..... 94, 97
  - External coupling ..... 117
  - FM ..... 83
  - Input impedance ..... 117
  - Overview ..... 121
  - Phase ..... 83
  - PhiM ..... 83
  - PM ..... 83
  - Pulse ..... 83
  - Source ..... 86
  - State ..... 86
- Modulation depth
  - AM ..... 91
- Modulation sensitivity
  - AM ..... 91
- Modulations state
  - Toggle ..... 82
- Mount network drive
  - How to ..... 322
- Mounting, in a rack ..... 29
- Mouse
  - Usage ..... 56
- Multiple files
  - Copy ..... 318, 327, 328
- Multiplier
  - Frequency ..... 73
- N**
- Naming conventions
  - Allowed file names ..... 302
- NAN ..... 756
- NAN (not a number)
  - Remote control ..... 760
- Navigation
  - Keys ..... 40
- Navigation controls
  - Overview ..... 40
- NDAC ..... 779
- Network
  - Connection fails ..... 729
  - Settings ..... 383

- Network share
  - Mapping ..... 320
  - Mapping, how to ..... 322
- Network status ..... 383
- New password
  - Setup (security) ..... 365
- New user password
  - Setup (security) ..... 364
- NINF ..... 756
- Noise
  - Distribution ..... 118
- Noise bandwidth limitation
  - System bandwidth ..... 118
- Noise generator
  - Bandwidth ..... 118
- Noise level
  - Absolute system bandwidth ..... 121
  - Relative system bandwidth ..... 121
- Noise ratio
  - Power sensors ..... 239
- NRFD ..... 779
- NRP
  - see Power analysis ..... 240
- NRP power viewer
  - Settings ..... 235
  - Use S-Parameter ..... 240
- NRP sensor mapping ..... 230
  - Add LAN sensor ..... 232
  - Add sensor ..... 232
  - Add USBTMC sensor ..... 232
  - Clear ..... 232
  - Connector ..... 231
  - Device ID ..... 232
  - Host name ..... 232
  - IP address ..... 232
  - Protocol ..... 231
  - Scan ..... 232
  - Sensor name ..... 231, 232
  - Serial number ..... 232
  - Settings ..... 231
- NTP
  - Address ..... 741
- NTRansition ..... 766
- Number of licenses ..... 733
- Numeric data entry ..... 61
- Numeric parameters ..... 62, 755
- Numeric values
  - Special ..... 756
- O**
- Offset
  - Frequency ..... 73
- Old password
  - Setup (security) ..... 365
- Old user password
  - Setup ..... 364
- On-screen keyboard ..... 62
- On-screen keypad ..... 59
- Open source acknowledgment (OSA) ..... 22
- Open-source acknowledgments ..... 733
- Operating mode
  - ILS glide slope ..... 145
  - ILS localizer ..... 152
- Operating site
  - Choosing ..... 27
  - Setting up the instrument ..... 28
- Operation
  - Manual ..... 56
- Operation complete
  - Remote ..... 437
- Operation hours ..... 731
- Operation mode ..... 311
- Option
  - Expiration date ..... 733
- Option: expiration date ..... 733
- Options
  - Analog modulation ..... 80
  - Identification (remote) ..... 437
- Oscillator
  - Reference ..... 288
- Output
  - Clk Syn ..... 298
  - LF ..... 120
  - SCPI list (select file) ..... 419
  - Source (LF output) ..... 123
- OUTPut
  - Subsystem ..... 474
- Output connector ..... 43, 46
- Output connectors
  - Clk Syn ..... 43, 46
  - Marker User1 ..... 46
  - Pulse Sync ..... 43, 47
  - RF ..... 42, 47
  - Stop ..... 46
  - V/GHz X-Axis ..... 45
  - Z-Axis ..... 45
- Output queue ..... 765
- Output, LF
  - Offset ..... 120
  - Voltage ..... 120
- Overlapping commands
  - Preventing ..... 761
- Overview
  - AM ..... 123
  - LF Out ..... 122
- P**
- Parallel poll register enable
  - Remote ..... 437
- Parameters
  - Block data ..... 757
  - Boolean ..... 756
  - Entering ..... 62
  - Numeric values ..... 755
  - SCPI ..... 755
  - Special numeric values ..... 756
  - String ..... 757
  - Text ..... 757
- Parity
  - RS232 interface ..... 387
- Password
  - Change (security password) ..... 365
  - Change (user password (security)) ..... 365
  - Confirm (security password) ..... 365
  - Confirm (user password (security)) ..... 364
  - Enter (security password) ..... 363
  - New (security password) ..... 365
  - New (user password (security)) ..... 364
  - Old (security password) ..... 365
  - Old user password ..... 364
  - Protection level ..... 355

- Security ..... 363
- Paste
  - Instrument settings ..... 320
- PCI bus ..... 731
- Phase
  - Subsystem ..... 661
- Phase modulation ..... 88
  - Deviation ..... 88
  - Deviation mode ..... 88
  - Mode ..... 89
  - Ratio ..... 89
  - Subsystem ..... 559
- Phase reference ..... 79
- PhiM
  - Deviation mode ..... 88
  - Mode ..... 89
  - Ratio ..... 89
  - Settings ..... 88
  - Total deviation ..... 88
- Ping
  - LXI ..... 397
- Placing, on a bench top ..... 28
- PLL bandwidth ..... 73
- PM ..... 80
  - Subsystem ..... 559
- Polarity
  - Pulse generator output ..... 103
  - Pulse modulation ..... 111
- Position
  - VOR ..... 137
- Power
  - Connecting the instrument ..... 31
  - UCOR ..... 221
- Power analysis ..... 240
  - Access ..... 243
  - Example ..... 245
  - Options ..... 240
  - Trace settings ..... 245
- Power Analysis Diagram
  - Power analysis ..... 244
- Power On ..... 39
- Power sensors
  - Activation ..... 237
  - Aperture time ..... 239
  - Auto once ..... 239
  - Filter ..... 238
  - Filter length ..... 239
  - Frequency ..... 238
  - Level (average) ..... 236
  - Level (peak) ..... 236
  - Level offset ..... 238
  - Noise ratio ..... 239
  - Serial number ..... 236
  - Source ..... 237
  - State ..... 237
  - State (level offset) ..... 238
  - Timeout ..... 239
  - Unit ..... 236
  - Update ..... 234
  - Use default aperture time ..... 239
  - Zero ..... 237
- Power Sensors
  - Display ..... 237
- Power supply
  - Connector ..... 47
- Power viewer
  - Auto once ..... 239
- Power-On
  - Settings ..... 340
- Power-On count ..... 732
- Power-On state
  - RF level ..... 340
- Power-On/EMF
  - About ..... 340
  - RF signal ..... 340
- PPE ..... 765
- Prefix, year, month, Day ..... 334
- Preparing for use ..... 27
- Preset
  - Factory preset ..... 308
- Print
  - Hard copy ..... 335
- Protection
  - Settings ..... 354
  - Setup ..... 353
- Protection level
  - 1 ..... 353
  - 2 ..... 354
  - 3, 4, 5 ..... 354
  - Adjustments ..... 353
  - Calibration ..... 354
  - Factory only ..... 354
  - Protection level ..... 355
  - Service department ..... 354
- Protocol
  - VXI ..... 376
- Ptransition ..... 766
- PULM
  - Delay ..... 103
  - Double pulse delay ..... 103
  - Double pulse width ..... 103
  - Impedance (trigger input) ..... 111
  - Mode ..... 99
  - Period ..... 102
  - Pulse polarity (input) ..... 111
  - Repetition frequency ..... 103
  - see PM ..... 83
  - Source ..... 84
  - State ..... 84
  - Subsystem ..... 563
  - Threshold (pulse input) ..... 111
  - Transition type ..... 84
  - Width ..... 102
- Pulse
  - Duty cycle ..... 115
  - Length (PULM) ..... 102
  - Period ..... 115
  - Width ..... 115
  - Width (PULM) ..... 102
- Pulse generator
  - Delay ..... 103
  - Output polarity ..... 103
  - Output state ..... 103
  - Single Trigger ..... 103
  - Subsystem ..... 659
  - Width ..... 102
- Pulse graph
  - Filename ..... 110
  - Zoom In/Out ..... 110
  - Zoom position ..... 110
  - Zooming ..... 110



- Pulse modulation ..... 83
  - Double pulse delay ..... 103
  - Double pulse width ..... 103
  - Mode ..... 99
  - Period ..... 102
  - Pulse input threshold ..... 111
  - Pulse polarity (input) ..... 111
  - Repetition frequency ..... 102, 103
  - see PM ..... 83
  - Select pulse train file ..... 105
  - Source ..... 84
  - State ..... 84
  - Subsystem ..... 563
  - Trigger input impedance ..... 111
  - Trigger mode ..... 100
- Pulse period
  - Chirp modulation ..... 95
- Pulse Sync connector ..... 43, 47
- Pulse train
  - File catalog ..... 105
  - Import/export ..... 108, 204, 227
  - On/off time ..... 106
  - Repetition ..... 106
  - Select ..... 105
- Pulse width
  - Chirp modulation ..... 96
- Pulsed marker
  - ILS marker beacons ..... 160
- Q**
- QR code ..... 391
- Queries ..... 751, 759
  - Status ..... 770
- Question mark ..... 757, 759
- Questionable status register ..... 769
- Quotation mark ..... 757
- R**
- R&S signed packages
  - Secure update policy ..... 356
- Rack installation ..... 47
- Rack, mounting ..... 29
- Radar systems
  - Overview ..... 126
- Radio navigation systems
  - Overview ..... 126
- Ratio
  - AM ..... 92
  - Amplitude modulation ..... 92
  - FM ..... 87
  - Frequency modulation ..... 87
  - Phase modulation ..... 89
  - PhiM ..... 89
- Readjust
  - Automatic level control ..... 78
- Recall
  - Instrument settings ..... 314
  - User menu ..... 343
- Recall instrument settings ..... 438, 449
- Recall intermediate ..... 314, 438
- Recommendations
  - remote control programming ..... 772
- Recorded SCPI commands
  - SCPI list ..... 418
- Redo ..... 368
  - Clear history ..... 369
  - History ..... 369
  - Settings ..... 369
  - State ..... 369
- REF deviation
  - VOR ..... 137
- Reference frequency output
  - 1 GHz ..... 292
  - 10 MHz, 100 MHz ..... 292
  - Loop through ..... 292
- Reference oscillator ..... 288
  - Adjustment ..... 293
  - Adjustment frequency ..... 294
  - External frequency ..... 290
  - Output frequency ..... 292
  - Preset ..... 290
  - Reference frequency, variable ..... 291
  - RF off state ..... 290
  - Source ..... 290
  - Synchronization bandwidth ..... 291
  - Use external tuning ..... 292
- Registers ..... 765
- Release notes ..... 22
- Reload
  - SCPI list ..... 419
- Remote access ..... 371
  - Active connections ..... 389
  - DNS server ..... 385
  - DNS suffix ..... 385
  - GPIO address ..... 386
  - GPIO resource (VISA resource string) ..... 385
  - HISLIP resource (VISA resource string) ..... 385
  - Identification ..... 388
  - IDN string ..... 389
  - Instrument emulations ..... 388
  - IP address mode ..... 384
  - Language ..... 388
  - Network gateway ..... 385
  - Network hostname ..... 384
  - Network IP address ..... 384
  - Network Mac address ..... 385
  - Network resource (Ethernet resource string) ..... 385
  - Network settings ..... 383
  - Network status ..... 383
  - OPT string ..... 389
  - QR code ..... 391
  - RS232 ..... 387
  - see Remote operation from a computer ..... 56
  - Serial ..... 385
  - Set IDN and OPT to default ..... 388
  - Settings ..... 382
  - Socket resource (VISA resource string) ..... 385
  - Subnet mask ..... 385
  - USB VISA resource string ..... 385
  - VISA resource strings ..... 385
  - Workgroup name ..... 384
- Remote control ..... 64
  - Basics ..... 751
  - GPIO ..... 411
  - Programming examples ..... 435
  - SCPI ..... 371
  - Source subsystem ..... 542
- Remote operation ..... 65
  - VNC ..... 371
- Remote trace
  - LXI ..... 397

- Removing sensitive data ..... 735
- REN ..... 779
- Rename
  - File ..... 450
  - Instrument settings ..... 320
- Repetition frequency
  - Pulse modulation ..... 103
- Reset
  - List mode ..... 202
  - RF frequency (delta phase) ..... 79
  - Sweep ..... 191
- Reset device parameters ..... 440
- Reset values
  - Remote ..... 438
- Resource string
  - VISA ..... 374
- Restoring configuration ..... 307
- Resulting file name ..... 334
- Retrace
  - Sweep ..... 188
- RF adapter port ..... 749
- RF combined sweep
  - State ..... 187
- RF connector ..... 42, 47
- RF frequency
  - Configuring ..... 67
- RF frequency sweep
  - State ..... 186
- RF level
  - Configuring ..... 67
  - EMF display ..... 340
  - Offset ..... 76
  - Power-On state ..... 340
  - Setting characteristics ..... 76, 195
  - Settings ..... 74
- RF level sweep
  - State ..... 187
- RF OFF mode
  - Attenuator settings ..... 213
- RF off state
  - Reference oscillator ..... 290
- RF ON, RF OFF, RF ON/OFF ..... 67
- RF output
  - Amplitude ..... 75
  - Harmonic filter ..... 77
  - Impedance ..... 67
  - Protection ..... 214
  - State ..... 67
- RF Output
  - Level range ..... 77
- RF output signal
  - Phase ..... 79
  - Phase reference ..... 79
- RF phase
  - Configuring ..... 67
- RF signal
  - Analog modulation ..... 80
  - Attenuator ..... 211
  - Connectors ..... 69
  - Frequency ..... 71
  - Power-On/EMF ..... 340
  - User correction ..... 216
- Right frequency
  - ILS localizer ..... 153
- Rotary knob ..... 40
  - User step ..... 301
  - User variation ..... 73, 78
- RS232
  - Baud rate ..... 387
  - Parity ..... 387
  - Remote access ..... 387
  - Stop bits ..... 387
- S**
- S-Parameter
  - Activate corrections ..... 240
- Safety instructions ..... 21
- Samba services
  - SMB client ..... 363
  - SMB server ..... 363
- SAMBA/SMB
  - How to access the instrument ..... 325
- Sanitize ..... 358
- Save
  - Editor ..... 106, 208, 223
  - Instrument settings ..... 313
  - Power analysis ..... 274
  - User menu ..... 343
- Save and load ..... 311
- Save as
  - Editor ..... 106, 208, 223
- Save hard copy as
  - bmp, jpg, png ..... 332, 333
- Save immediate ..... 313
- Save instrument settings ..... 438, 451
- Save intermediate ..... 438
- Save to Ref
  - Power analysis ..... 247
- Save/Recall ..... 311
  - ADF ..... 134, 142, 165
  - Dialog ..... 311
  - How to ..... 314
  - ILS ..... 134, 142, 165
  - SCPI-Export ..... 420
  - VOR ..... 134, 142, 165
- Saving ..... 52
- Scan
  - NRP sensor mapping ..... 232
- SCPI
  - Error messages ..... 725
  - Export ..... 317
  - Export settings ..... 418
  - Import ..... 317
  - LAN services ..... 362
  - Output file ..... 419
  - Parameters ..... 755
  - Syntax ..... 753
  - Version ..... 374
- SCPI confirmed commands ..... 751
- SCPI export ..... 419
  - Select file ..... 419
  - Show file content ..... 419
- SCPI Export
  - Format ..... 418
- SCPI list
  - Commands of all settings ..... 313
  - Display ..... 417
  - Export ..... 418
  - Recorded SCPI commands ..... 418
  - Show all commands ..... 313
- SCPI remote trace
  - LXI ..... 397

- SCPI script
  - Select ..... 347
- SCPI-Export
  - Save/Recall ..... 420
- Screen saver
  - Activate ..... 341
  - State ..... 339
  - Wait time ..... 339
- SD card slot ..... 41
- Secure update policy
  - All packages ..... 356
  - Confirm unsigned ..... 356
  - R&S signed packages ..... 356
- Security
  - Accept settings ..... 363
  - Change password (setup) ..... 365
  - Change user password (setup) ..... 365
  - Confirm password (setup) ..... 365
  - Confirm user password (setup) ..... 364
  - Display lock ..... 359
  - Enter password (setup) ..... 363
  - New password (setup) ..... 365
  - New user password (setup) ..... 364
  - Old password (setup) ..... 365
  - Old user password ..... 364
  - Password management ..... 363
  - Sanitize ..... 358
  - Secure update policy ..... 356
  - Security password ..... 365
  - Settings ..... 355
  - Setup ..... 353
  - USB storage (setup) ..... 357
  - User name (setup) ..... 364
  - User password ..... 364
  - Volatile memory ..... 358
- Security password
  - Security ..... 365
  - Setup ..... 365
- Security procedures ..... 21
- Security settings ..... 353
- Select
  - List mode data file ..... 202
  - Setup file ..... 347
  - User correction data file ..... 220
- Select file ..... 317
- Self-test
  - Remote ..... 439
- Selftests
  - About ..... 739
- Sensitive information
  - Protecting ..... 303, 310
- Sensor name
  - NRP sensor mapping ..... 232
- Sequential commands ..... 760
- Serial bus ..... 731
- Serial number ..... 402
  - NRP sensor mapping ..... 232
  - Power sensors ..... 236
- Service manual ..... 21
- Service request (SRQ) ..... 767, 770
- Service request enable register (SRE) ..... 767
  - Remote ..... 439
- Services
  - LAN ..... 361
- Set IDN and OPT to default
  - Emulation mode ..... 388
- Set to default ..... 133, 142, 165
- Set up remote control
  - GPIB ..... 411
- Setting commands ..... 751
- Settings
  - Active connections ..... 389
  - ALC ..... 215
  - AM ..... 89
  - Attenuator ..... 212
  - Automatic level control ..... 215
  - Check front panel ..... 742
  - Display ..... 338
  - Instrument emulations ..... 388
  - Internal adjustments ..... 745
  - Keyboard ..... 338
  - List mode ..... 199
  - Managing ..... 302
  - NRP power viewer ..... 235
  - NRP sensor mapping ..... 231
  - On power-on ..... 340
  - Protection ..... 354
  - Remote access ..... 382
  - RF level ..... 74
  - SCPI export ..... 418
  - Security ..... 355
  - UCOR ..... 219
  - Undo/Redo ..... 369
  - User key ..... 346
- Setup
  - Accept security settings ..... 363
  - Adjusting display ..... 337
  - Adjusting keyboard ..... 337
  - Annotation frequency ..... 359
  - Annotation level ..... 359
  - Change password ..... 365
  - Change password (security) ..... 365
  - Confirm password ..... 364
  - Confirm password (security) ..... 365
  - Display lock ..... 359
  - Enter password (security) ..... 363
  - GUI update ..... 337
  - Keyboard settings ..... 338
  - Layout (keyboard) ..... 339
  - New password ..... 364
  - New password (security) ..... 365
  - Old password (security) ..... 365
  - Password (protection) ..... 355
  - Performing the front panel test ..... 742
  - Protection level ..... 355
  - Screen saver ..... 339
  - Secure update policy ..... 356
  - Security password ..... 365
  - USB storage (security) ..... 357
  - User name (security) ..... 364
  - User password ..... 364
  - Wait time ..... 339
- Setup files
  - Data exchange ..... 330
- Setup key ..... 337
- Shape
  - LF generator ..... 113
  - LF output ..... 113
  - Period ..... 115
  - Pulse duty cycle ..... 115
  - Pulse width ..... 115
  - Sweep ..... 189
  - Trapeze high ..... 116

- Trapezoid rise, fall ..... 116
- Triangle rise ..... 116
- Shortcut to a network drives
  - How to ..... 322
- Show
  - SCPI list ..... 313
- Show file content
  - SCPI export ..... 419
- Show SCPI command ..... 417
  - Close ..... 417
  - Copy ..... 417
- Signal
  - ILS glide slope ..... 145
  - ILS localizer ..... 152
  - ILS marker beacons ..... 160
  - VOR ..... 135
- Signal output
  - LF ..... 119
- Signal source
  - Analog modulation ..... 80
- Single
  - Execute (list mode) ..... 202
- Single trigger
  - Chirp modulation ..... 96
- SMB (Samba)
  - LAN services ..... 362
- Softkey bar
  - see Taskbar ..... 58
- Source
  - AM, FM,  $\Phi$ M ..... 86
  - Analog modulation ..... 80
  - LF output ..... 120, 123
  - Power sensors ..... 237
  - Pulse modulation ..... 84
  - Reference oscillator ..... 290
  - Sweep trigger ..... 187
- Source subsystem
  - Remote control commands ..... 542
- Spacing
  - Frequency sweep ..... 190, 193
  - RF frequency / level sweep ..... 190, 193
  - RF level sweep ..... 195
- Span
  - Frequency sweep ..... 193
- SRE ..... 765
- SRE (service request enable register) ..... 767
- SRQ ..... 779
- SRQ (service request) ..... 767, 770
- SSH
  - LAN services ..... 362
- Standard settings ..... 133, 142, 165
- Standby ..... 39
- Start
  - Frequency sweep ..... 192
  - Power analysis ..... 245
  - RF level sweep ..... 194
- State
  - ADF ..... 133, 142, 165
  - Adjustment (reference oscillator) ..... 293
  - AM, FM,  $\Phi$ M ..... 86
  - Automatic level control ..... 216
  - Chirp modulation ..... 94
  - Clock synthesis ..... 299
  - DC offset ..... 300
  - ILS ..... 133, 142, 165
  - LF frequency sweep ..... 113, 187
  - List mode ..... 200
  - Power sensors ..... 237
  - Pulse generator output ..... 103
  - Pulse modulation ..... 84
  - RF frequency / level sweep ..... 187
  - RF frequency sweep ..... 186
  - RF level sweep ..... 187
  - RF output ..... 67
  - RF output protection ..... 214
  - Screen saver ..... 339
  - UCOR ..... 220
  - Undo/Redo ..... 369
  - VOR ..... 133, 142, 165
- Status
  - Queries ..... 770
- Status bar
  - Display ..... 57
- Status byte
  - Remote ..... 436, 439
- Status byte (STB) ..... 767
- Status information ..... 351
- Status register
  - Response format definition ..... 468
- Status registers ..... 765
  - CONDITION ..... 766
  - ENABLE ..... 766
  - EVENT ..... 766
  - model ..... 766
  - NTRansition ..... 766
  - parts ..... 766
  - PTRansition ..... 766
- Status reporting system ..... 763
  - Application ..... 770
  - Common commands ..... 435
- Status settings
  - LXI ..... 392
- STB ..... 765
- Step
  - Frequency sweep ..... 193
  - Linear (frequency sweep) ..... 193
  - Logarithmic (frequency sweep) ..... 193
  - RF level sweep ..... 195
- Step Attenuator below 20 GHz
  - Attenuator settings ..... 213
- Step count
  - Combined RF frequency / level sweep ..... 195
- Step width
  - User variation ..... 73, 78, 301
- Stop
  - Frequency sweep ..... 192
  - Power analysis ..... 245
  - RF level sweep ..... 194
- Stop bits
  - RS232 interface ..... 387
- Stop connector ..... 46
- Storage ..... 739
- Storage location
  - /usb/ ..... 302
  - /var/user ..... 302
  - /var/volatile ..... 302
  - Mass memory ..... 441
- Store
  - Save ..... 311
- Storing files ..... 443
- String in remote commands ..... 757
- Subcarrier depth
  - VOR ..... 136

- Subcarrier frequency
  - VOR ..... 136
- Subnet mask ..... 385
- Subsystem
  - AM ..... 544
  - CHIRp ..... 550
  - FM ..... 554
  - Keyboard ..... 473
  - Phase ..... 661
  - PM ..... 559
  - Power ..... 662
  - PULM ..... 563
  - Pulse generator ..... 659
- Suffixes ..... 754
- Sum of depth
  - ILS glide slope ..... 147
  - ILS localizer ..... 154
- Support ..... 735
- Sweep
  - Center frequency ..... 192
  - Current frequency ..... 187
  - Current level ..... 187
  - Dwell time ..... 190
  - Execute single ..... 191
  - Frequency span ..... 193
  - Level range ..... 196
  - Mode ..... 187
  - Reset ..... 191
  - Retrace ..... 188
  - Shape ..... 189
  - Spacing ..... 190, 193, 195
  - Start/stop frequency ..... 192
  - Start/stop level ..... 194
  - State (LF frequency) ..... 113, 187
  - State (RF combined) ..... 187
  - State (RF frequency) ..... 186
  - State (RF level) ..... 187
  - Step ..... 193, 195
  - Trigger manually ..... 191
- Sweep time
  - RF sweep ..... 190
- Sweep type
  - Frequency sweep ..... 186, 197
- Switching
  - On or off ..... 35
- Sync with glide slope
  - ILS ..... 144, 151
- Sync with localizer
  - ILS ..... 144, 151
- Synchronization bandwidth
  - Reference oscillator ..... 291
- Syntax elements
  - SCPI ..... 757
- Synthesizer
  - PLL bandwidth ..... 73
- System
  - Factory preset ..... 308
- System bandwidth
  - Noise level (absolute) ..... 121
  - Noise level (relative) ..... 121
- T**
  - Tab labels ..... 59
  - Temperature offset
    - Internal adjustments ..... 746
  - Temporary files ..... 303, 310
  - Test
    - Check front panel ..... 742
  - Text entry ..... 61
  - Text paramters in remote commands ..... 757
  - Threshold
    - Pulse modulation ..... 111
  - Tile diagram
    - Display ..... 57
  - Time
    - UTC ..... 740
  - Timeout
    - Filter (power sensors) ..... 239
  - Tooltips
    - Show ..... 63
  - Touchscreen
    - Compared with mouse ..... 56
    - Usage ..... 56
  - Touchscreen test
    - Perform ..... 743
  - Trace
    - Power analysis ..... 245
  - Trace indication
    - Power analysis ..... 247
  - Trace settings
    - Power analysis ..... 259
  - Traces
    - Power analysis ..... 245
  - Traicing
    - Messages ..... 413
    - SCPI commands ..... 413
  - Transition
    - PULM ..... 84
    - Pulse modulation ..... 84
  - Trapezoid
    - High (LF generator) ..... 116
    - Rise, fall ..... 116
  - Triangle
    - Rise ..... 116
  - Trigger
    - Event (remote) ..... 439
    - Execute (list mode) ..... 202
    - Power Sensors ..... 266
    - Sweep, manually ..... 191
  - Trigger mode
    - Chirp modulation ..... 96
  - Trigger source
    - List mode ..... 201
    - Sweep ..... 187
  - Tripped
    - RF output protection ..... 214
  - Type
    - AM ..... 90
- U**
  - UCOR
    - About ..... 217
    - Data ..... 220
    - Display correction value ..... 220
    - Edit data ..... 221
    - Export user data ..... 109, 205, 228
    - File catalog ..... 220
    - File settings, import/export ..... 108, 204, 227
    - Fill with sensor ..... 225
    - Import/export ..... 108, 203, 204, 227
    - Load from file ..... 109, 204, 227
    - RF signal ..... 216

- Select file ..... 220
  - Settings ..... 219
  - State ..... 220
  - Values, defining ..... 207, 222
  - Undo ..... 368
    - Clear history ..... 369
    - History ..... 369
    - Settings ..... 369
    - State ..... 369
  - Unpacking the instrument ..... 27
  - UP ..... 756
  - Up frequency
    - ILS glide slope ..... 146
  - Up/Down phase
    - ILS glide slope ..... 146
  - USB
    - Interfaces ..... 377
    - Storage (security) ..... 357
  - Use default aperture time
    - Power sensors ..... 239
  - User correction
    - see UCOR ..... 216
  - User data
    - Access ..... 315
    - Load from a specific directory ..... 443
  - User files ..... 302
  - User interface
    - Lock ..... 359
  - User key ..... 342
    - Action name ..... 346
    - Add, change, delete action ..... 347
    - Assign actions ..... 348
    - Define action ..... 346, 347
    - SCPI command ..... 347
    - Select dialog ID ..... 347
    - Settings ..... 346
    - Toggle between define and execute mode ..... 347
  - User manual ..... 21
  - User menu ..... 342
    - Access ..... 344
    - Clear ..... 343
    - Create ..... 344
    - Recall ..... 343
    - Save ..... 343
    - Settings ..... 343
  - User name
    - Setup (security) ..... 364
  - User password
    - Security ..... 364
    - Setup ..... 364
  - User preset ..... 307
  - User variation
    - Activating ..... 73, 78, 301
    - Clock synthesis ..... 301
    - Level ..... 73, 78
    - RF ..... 73, 78
  - User-definable preset
    - Recall ..... 343
  - Utility keys
    - Overview ..... 38
- V**
- V/GHz
    - Frequency sweep ..... 196
  - V/GHz X-Axis connector ..... 45
- VAR depth
    - VOR ..... 136
  - VAR/REF frequency
    - VOR ..... 136
  - Variable reference frequency ..... 291
  - Varying
    - RF frequency and level ..... 73, 78
  - Version
    - Firmware ..... 732
  - Vertical stroke ..... 757
  - VISA ..... 374
    - Libraries ..... 379
    - Resource string ..... 374
  - Visa resource string
    - Ethernet ..... 385
    - GPIB ..... 385
    - HISLIP ..... 385
    - Serial ..... 385
    - Socket ..... 385
    - USB ..... 385
  - Visa resource strings ..... 385
  - VNC
    - LAN services ..... 362
    - Using in a LAN ..... 65
  - Volatile memory ..... 303, 310
  - Volatile mode
    - Activate ..... 358
  - VXI protocol ..... 376
- W**
- Wait
    - Remote ..... 439
  - Wait time
    - Screen saver ..... 339
  - Warnings ..... 724, 727
  - White papers ..... 22
  - White space ..... 757
  - Wi-Fi
    - WLAN ..... 427
  - Width
    - Double pulse (PULM) ..... 103
    - PULM ..... 102
    - Pulse modulation ..... 102
  - Workgroup name ..... 384
- X**
- X-Axis
    - Frequency sweep ..... 196
- Y**
- y-axis
    - Power analysis ..... 257
- Z**
- Z-Axis connector ..... 45
  - Zero
    - Power Sensors ..... 237
  - Zero - Power Sensors ..... 494
  - Zeroconf
    - IP address ..... 729
  - Zeroconf (APIPA) protocol ..... 400
  - Zoom In/Out
    - Pulse graph ..... 110

Zoom position	
Pulse graph .....	110
Zooming	
Pulse graph .....	110