

Marman®

V-Band Couplings, Flanges, Band Clamps and Strap Assemblies

Industrial Clamp Products

- Versatile
- Strong
- Dependable
- Available in different shapes and sizes



EATON

Powering Business Worldwide

Table of Contents

3	Introduction
4	Descriptive Index
5	Fast Information Finder
6	Capabilities
8	How to Order/General Purpose
7	Marman V-Band Couplings
25	V-Band Coupling Flanges
31	Band Clamps - Band Straps
43	Engineering Data

Eaton Industrial Clamp Products...A Total Commitment

Eaton's commitment to you is found in many aspects of our business. Our company's design, engineering and manufacturing capabilities are available to assist in providing a clamp to meet your exact specifications.

Beginning with Eaton's strong customer service response program, orders and inventories are computerized so that your needs are met quickly.

Our skilled draftsmen and engineers work together to perfect the details involved in the design of each clamp. A state-of-the-art CAD system is utilized in the development of clamp products.

An initial step in the manufacturing process is the roll forming of V-Retainer sections. Spot-welding on a V-Band coupling is then completed.

Throughout the manufacturing process, various inspections, including statistical process control, are performed on all clamp products to ensure quality.

Eaton's clamp manufacturing plant in Eastanolee (Toccoa), Georgia is just one Eaton location that offers the customer worldwide availability of our clamp products.

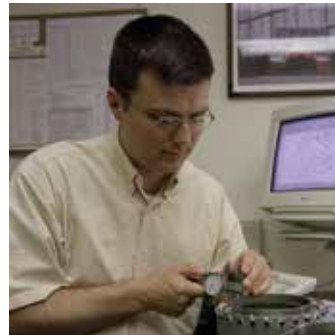

	Page		Page
Capabilities	6	Marman V-Band Couplings	6 – 24
Band Clamps	32 – 39	Adjustable Over Center Latch	22 – 24
Adjustable	37	General Purposes	12 – 17
Adjustable Over Center Latch	38	Light Duty	20
Cradle Support	39	Non-Adjustable Over Center Latch	21
Heavy Duty	34	Selection Guide	9
Multiple Take-up	33	Selection Procedure	10 – 11
Spring Loaded	35	Servicemaster	18 – 19
T-Bolt	32	Marman V-Band Couplings Selection Guide	9 – 11, 44
Universal	36	Material and Temperature Correction Charts	45
Utility	33	Part Number to Page Index	5
Band Straps	40 – 41	Strap Assemblies	40 – 41
Band Strength Chart	46	V-Band Coupling Flanges	25 – 29
Bolt Strength Chart	45	Machined	28
Coupling Styles	8	Material and Temperature Correction	45
Engineering Data	43 – 46	Schedule 40 Pipe	29
Flange Section Chart	27	Selection Chart	27
Latch Styles	8	Selection Guide	26
		Tube	29

- **Have an Eaton part number and need more information?** Use the part number to page index in this listing to get the exact page of the full product description.

Part Number to Page Index

Part Number	Page	Part Number	Page	Part Number	Page	Part Number	Page	Part Number	Page	Part Number	Page
820	36	MB5415	41	MB5606	40	MFM5703	29	MV84735	14	MV87097	12
55000	19	MB5416	41	MB5608	40	MV80009	20	MV84754	13	MV87107	12
55083	34	MB5417	41	MB5609	41	MV81802	16	MV84764	14	MV87127	13
56400	28	MB5418	41	MB5610	40	MV81834	16	MV85623	15	MV87137	13
56401	28	MB54 19	41	MB56 11	41	MV81841	16	MV85633	14	MV87 147	14
57120	36	MB5420	41	MB5612	40	MV81865	16	MV85643	13	MV87157	14
MB5300	40	MB5421	41	MB5613	41	MV82652	12	MV85653	14	MV87177	15
MB5306	40	MB5423	41	MB5614	41	MV82653	12	MV85663	16	MV88018	12
MB5308	40	MB5424	41	MB5615	41	MV82734	12	MV85826	15	MV88098	12
MB5309	41	MB5425	41	MB5616	41	MV82751	12	MV85836	14	MV88108	12
MB5310	40	MB5426	41	MB5617	41	MV82795	12	MV85846	13	MV88128	13
MB5311	41	MB5427	41	MB5618	41	MV83102	13	MV85856	14	MV88138	13
MB5312	40	MB5428	41	MB5619	41	MV83134	13	MV85866	16	MV88148	14
MB5313	41	MB5429	41	MB5620	41	MV83152	12	MV86052	16	MV88158	14
MB5314	41	M85500	40	MB5621	41	MV83153	12	MV86074	16	MV88178	15
MB5315	41	MB5506	40	MB5623	41	MV83194	12	MV86082	15	MV88188	16
MB5316	41	MB5508	40	MB5624	41	MV83522	12	MV86083	15	MV89019B	21
MB5317	41	MB5509	41	MB5625	41	MV83523	12	MV86104	15	MV89079	22
MB5318	41	MB5510	40	MB5626	41	MV83564	12	MV86115	15	MV89099B	21
MB5319	41	MB5511	41	MB5627	41	MV83571	12	MV86122	16	MVT89029	23
MB5320	41	MB55 12	40	MB5628	41	MV83595	12	MV86123	16	MVT89039	24
MB5321	41	MB5513	41	MB5629	41	MV83652	13	MV86144	16	NE100899	35
MB5323	41	MB5514	41	M89325	32	MV83653	13	MV86155	16	NH200110	37
MB5324	41	MB5515	41	MB9336	33	MV83682	14	MV86162	15		
MB5325	41	MB5516	41	MB9360	38	MV83724	14	MV86163	15		
MB5326	41	MB5517	41	MB9425	32	MV83731	14	MV86184	15		
MB5327	41	MB5518	41	MB9446	33	MV84034	14	MV86195	15		
MB5328	41	MB5519	41	MB9460	38	MV84042	14	MV86242	17		
MB5329	41	MB5520	41	MB9525	32	MV84043	14	MV86243	17		
MB5400	40	MB5521	41	MB9560	38	MV84091	14	MV86264	17		
MB5406	40	MB5523	41	MB9625	32	MV84252	15	MV86275	17		
MB5408	40	MB5524	41	MB9802	33	MV84301	15	MV86276	17		
MB5409	41	MB5525	41	MB9914	39	MV84324	15	MV86282	17		
MB5410	40	MB5526	41	MB9915	39	MV84581	13	MV86283	17		
MB5411	41	MB5527	41	MFF61196	18,19	MV84594	13	MV86304	17		
MB5412	40	MB5528	41	MFM5700	29	MV84682	13	MV86315	17		
MB5413	41	MB5529	41	MFM5701	29	MV84701	13	MV86316	17		
MB5414	41	MB5600	40	MFM5702	29	MV84725	13	MV87017	12		

What are V-Band Couplings? Where can they be used?

V-Band Couplings are supplied in different configurations and latch styles to join tubing, piping, containers, filters, separators, regulators and other enclosures.

The V-shaped retainer shown in the cross-section view at the right is the portion of the coupling that wedges the flanges together. The strength of the coupling is in part determined by the retainer thickness, shape and material.

How it looks

Since there is a direct relationship between coupling design and cost, a prudent way to control costs is to insure that you select only that retainer cross-section and overall design that meets your application.

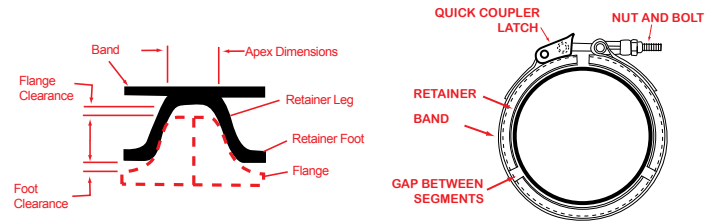

The Principle

As torque is applied to the nut of the coupling, an inward radial force is created in the retainer. This force wedges the flanges together. The flange and foot clearance must be maintained to prevent the retainer from bottoming out on the flanges before the necessary loading has been reached.

- Optimal strength is created by converting radial clamping force into axial sealing force.
- By use of a tension band and a means of tightening the band, the retainer is brought to bear directly upon the component flanges.
- The retainer exerts an axial force on the flanges with an 8.6 to 1 mechanical advantage as the band is tensioned.

How it works

- The retainer, unlike bolted flanges, applies a uniform closing force around the circumference of the flanges during and after tightening.

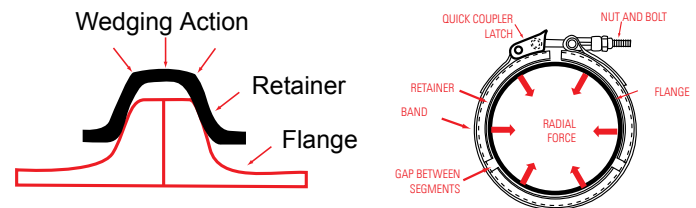

The Advantages of V-Band Couplings

- V-Band Couplings are simple solutions to the problem of replacing bolt flanges.
- Reduces assembly cost, saving in time and ease of accessibility.
- Ideal for applications requiring frequent access for cleaning, inspection or replacement of internal components.
- Many advantages over bolted flanges; smaller envelope dimensions; weight savings; improved appearance; cost reduction and ease of assembly.
- May be supplied in a wide range of sizes, shapes, materials and metal thicknesses.
- Choice of T-Bolt, quick coupler, or saddle latch is available (see page 8).
- Some styles of Eaton couplings include an integral band which covers the full circumference of the V-Band Coupling. This band provides additional strength by absorbing all circumferential or hoop load.

- As there is a direct relationship between design and cost in this coupling, care should be taken to select the correct retainer section and overall design to meet the strength required, as well as control cost.

Section Index	Page
Adjustable Over Center Latch	22-24
Coupling and Latch Styles	8
General Purpose	12 - 17
How to Order, General Purpose	8
Light Duty	20
Non-Adjustable Over Center Latch	21
Selection Guide	9
Selection Procedure	10-11
Servicemaster	18-19

How to Order/General Purpose Marman V-Band Couplings

To order any of the V-Band Couplings shown on pages 12 – 17, you must use complete part number.

MV00000 K J 000 T

Basic Part Number _____

As shown in tables on pages 12–17

Latch Code (T or K) see below _____

Material Code _____

E= 321 Stainless Steel and Retainer, 316 Stainless Steel Bolt
J= 316 Stainless Steel Band and Retainer, 316 Stainless Steel Bolt
R= 301 Stainless Steel Band and Retainer, 8740 Alloy Steel Bolt
S= 301 Stainless Steel Band and Retainer, 316 Stainless Steel Bolt

Nom Dia. (100 = 1.00 in.; 1000= 10.00 in.) _____

Nut Code _____

C= Plated Steel Hex Nut
F= Plated Steel Fiber Insert Hex Locknut
T= Stainless Steel Hex Nut
V= Stainless Steel All Metal Hex Locknut (Not recommended with alloy steel bolt)



C F T V

Coupling Latch Styles

<p>1 one latch one retainer segment (retainer without band) Quick Coupler Latch Only</p>	<p>2 one latch two retainer segments Quick Coupler Latch or T-Bolt Latch</p>	<p>3 one latch three retainer segments Quick Coupler Latch or T-Bolt Latch</p>	<p>4 two latches two retainer segments Quick Coupler plus T-Bolt or Two T-Bolt Latches</p>
<p>5 two latches two retainer segments (retainer without band) Quick Coupler plus T-Bolt or Two T-Bolt Latches</p>	<p>6 two latches four retainer segments Quick Coupler plus T-Bolt or Two T-Bolt Latches</p>	<p>7 one latch one retainer segment (retainer without band) Quick Release Saddle Latch</p>	<p>8 one latch two retainer segments Quick Release Saddle Latch</p>

Latch Styles

<p>T-bolt Latch/Latch code T Coupling styles 1 thru 6</p>	<p>Quick Coupler Latch/Latch code K Coupling styles 1 thru 6</p>	<p>Quick Release Saddle Latch/Latch code K Coupling styles 1 thru 6</p>
--	---	--

Considerations in Choosing Latch Styles

- Three segment couplings provide the optimum balance in ease of assembly, disassembly and economics.
- Multiple latches are recommended for diameters of 8 in. (203.2 mm) and greater.
- Quick Coupler Latch or Quick Release Saddle Latch should be used where frequent opening is needed.
- T-Bolt Latch should be used for semi-permanent closures and for additional safety on pressure vessels.

CAUTION: SYSTEM PRESSURE MUST BE RELEASED BEFORE UNFASTENING COUPLING.

To give the user greater design flexibility in the selection of V-Band Couplings, many different configurations are illustrated. Care should be taken in coupling selection to avoid over-designing. The correct retainer section in the most economical material to meet the strength and environmental condition required for the application should be specified. 316 Stainless Steel (J material code) is recommended for saltwater, chemicals, and other corrosive environments.

In the section covering General Purpose Couplings (pages 12 through 17), it should be noted that some of the styles include a band on top of the retainer (see cross-section view at right) that covers the full circumference of the V-Band Coupling. The band provides additional coupling strength by absorbing all of the circumferential or hoop load. Some of the styles do not include the band, and these, of course, are not as strong but may be more economical.

It should also be noted that some of the coupling styles use one retainer segment, while others utilize two or three. The segmented sections provide added flexibility. The more segments in a coupling, the greater the ease of assembly and disassembly.

A choice is provided between T-Bolt, Quick Coupler or Saddle Latches. The T-Bolt Latch is usually specified where a permanent or semi-permanent closure is required. The Saddle or Quick Coupler Latch is usually specified where frequent opening or closing is needed and on single retainer segment couplings for ease of assembly.

Multiple Latch Style V-Band Couplings are usually specified for couplings of diameters eight inches or larger.

A V-Band Coupling should be selected on the basis of strength required for the particular application. The cost of the coupling increases in relation to the strength required; therefore, the coupling selected should be no stronger than necessary to provide the most economical coupling for the application.

The strength of the coupling is determined primarily by the retainer thickness and shape. Use of different materials also affects the strength. The retainer (shown on this page) is the V-shaped portion of the coupling that wedges the flanges together.

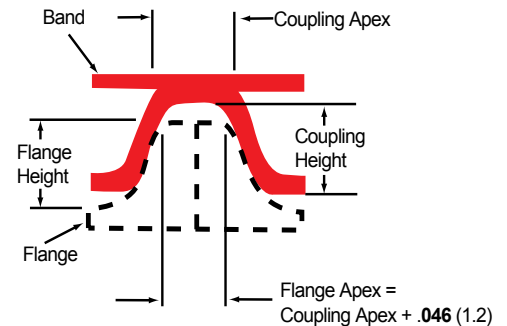

Coupling burst pressure conditions are shown in the detailed performance charts instead of operating pressures since the safety factor over operating conditions might vary with each application.

CAUTION: SYSTEM PRESSURE MUST BE RELEASED BEFORE UNFASTENING COUPLING.

In the selection of V-Band Couplings, the following should be used as a guide to insure performance:

1. The coupling nominal diameter is equal to flange O.D. + .12 in. (3.05 mm).
2. The nominal flange apex width is .046 in. (1.2 mm) greater than the coupling apex width for a 40° included angle retainer.

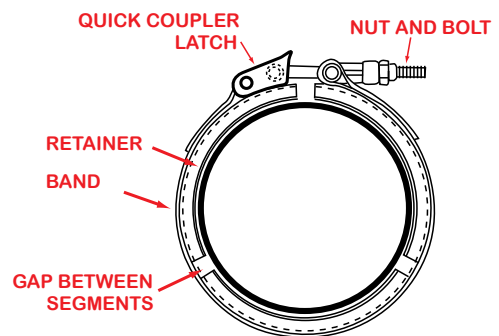

Flange Selection

Eaton customers may provide their own flanges by rolling or forming the flange as an integral part of the equipment, or Eaton flanges (pages 25 through 29) may be used with Marman V-Band Couplings.

For Use Over Your Flanges

In selecting a V-Band Coupling for use over your flanges the following steps should be taken.

1. Determine the following requirements: system burst pressure, operating temperatures and flange dimension for closed position.

COUPLING and FLANGE CROSS-SECTION

2. Determine nominal diameter of coupling: Nominal Diameter = Flange O.D. + .12 in. (3.0 mm). This .12 in. (3.0 mm) allows for .06 in. (1.5 mm) clearance between flange O.D. and coupling nominal diameter.

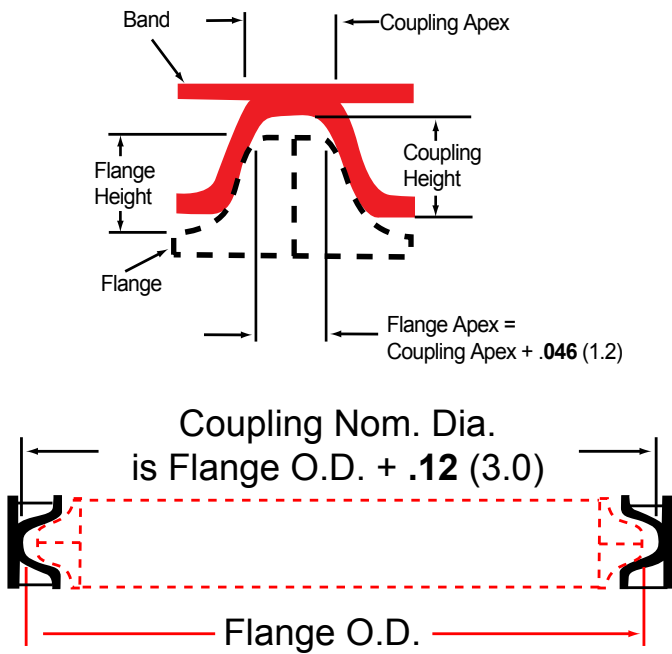

COUPLING and FLANGE CROSS SECTION

3. Determine proper retainer cross-section. Referring to retainer cross-sections, pages 12 to 17, pick a retainer which fits your flange apex and height. If flange dimensions shown in catalog do not meet your flange apex and height dimensions, consult Eaton, or if possible, change your flanges to meet dimension shown in catalog.
4. Determine coupling burst pressure rating. Using nominal diameter determine burst pressure from the appropriate graph similar to that shown in the next column. Note, the red curve is for coupling styles 1, 5 and 7. The black is for all other coupling styles.

Material	+ 70° F + 21.1 °C	+200 °F + 93.3° C	+400°F +204.4°C	+600°F +315.6°C	+800°F + 426.7°C
301 Stainless Steel	1.00	.88	.75	.68	.60
316 Stainless Steel	.50	.47	.44	.42	.39

5. Correct for temperature and material changes. Material selection should be based on strength requirements and environmental conditions. If an elevated temperature is required, or if a material other than 301 stainless steel is to be used, multiply the coupling burst pressure rating by correction factor specified in the chart below.

Coupling Burst Pressures

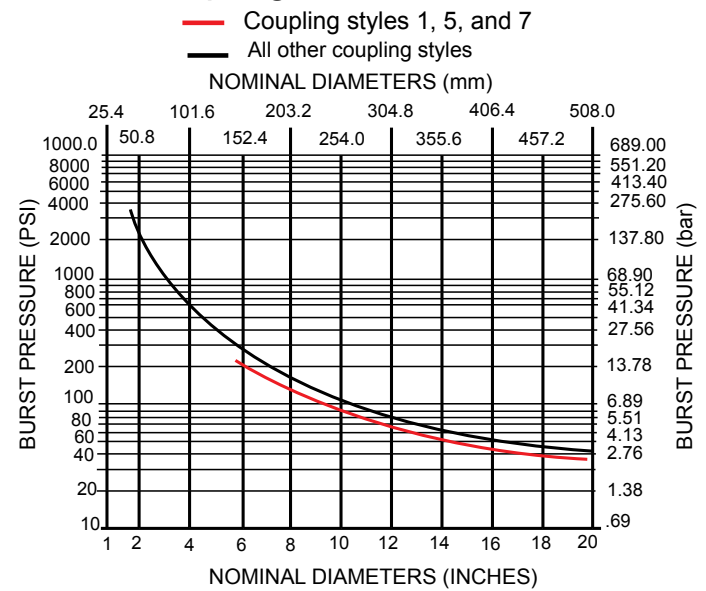

CAUTION: SYSTEM PRESSURE MUST BE RELEASED BEFORE UNFASTENING COUPLING.

6. Compare coupling burst pressure rating to required system burst pressure.
 - (a) If required system burst pressure is less than the rated coupling burst pressure, the coupling will do the job.
 - (b) If required burst pressure is higher than coupling burst pressure rating another retainer cross-section must be used. Use the same cross-section of thicker material or with full outer band.
7. Pick coupling and latch style and then determine part number from page 8. Note: Refer to Section 4 (Engineering Data) for further information on V-Band Coupling selection when bending or axial loads are involved.

Example:

1. Requirements: Required burst pressure = **200 psig** (13.78 bar).

Flange Dimensions:

Flange apex (closed position) = **.255 in.** (6.5 mm)
 Flange angle = 20° (40° included)
 Flange O.D. = **6.75 in.** (171.5 mm)

Operating temperature = **+70°F** (21.1° C)
 Coupling Material: Stainless Steel

2. Determine Nominal Diameter
 Nom. Dia. = Flange O.D. + **.12 in.** (3.0 mm)
 = **6.75 in.** (171.5 mm) + **.12 in.** (3.0 mm)
 = **6.87 in.** (174.5 mm)
3. Determine retainer cross-section: Refer to pages 12 to 17. (Proceed from Retainer #1 thru the remaining retainers until a retainer fits the **.255 in.** (6.5 mm) flange apex and **.281 in.** (7.1mm) flange height dimension requirements. Retainer #5 meets these requirements. (See below).

Retainer 2

**Min. Nom. Dia.: 2.00 in
 (50.8 mm)**

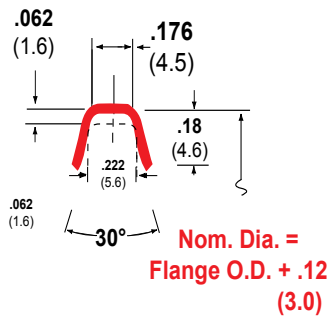

Retainer Thickness:
.025in. (.81 mm)
.040 in. (1.02 mm) on dia.
 under **4.00 in.** (101.6 mm)

4. Using nominal diameter, determine coupling burst pressure rating (use chart in next column).
 Coupling burst pressure = **210 psig** (14.47 bar) for style 2, 3, 4 and 8.

Coupling Bust Pressures

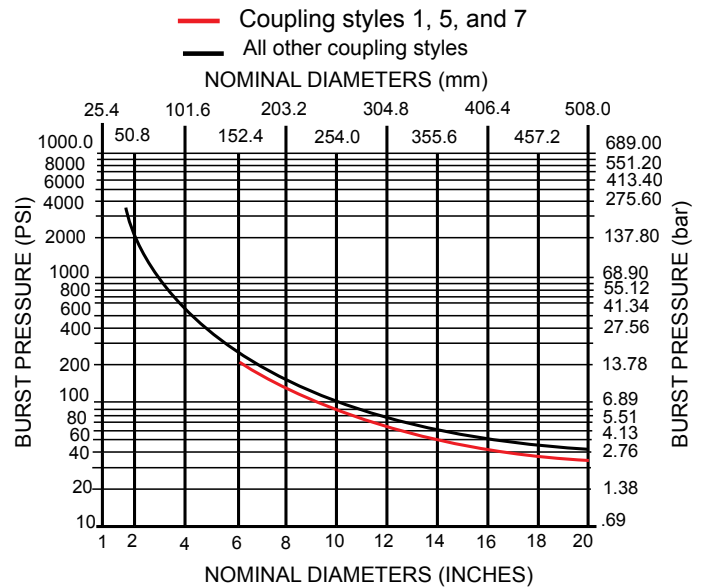

5. Correct for temperature and material changes. Determine correction factor from table below.

The corrected coupling burst pressure rating = coupling burst pressure rating X correction factor. Corrected coupling burst pressure for **+70°F** (21.1° C), 301 stainless steel = **210 psig** (14.47 bar) X 1 = **210 psig** (14.47 bar).

Material	+ 70° F + 21.1° C	+200° F + 93.3° C	+400° F +204.4° C	+600° F +315.6° C	+800° F + 426.7° C
301 Stainless Steel	1.00	.88	.75	.68	.60
316 Stainless Steel	.50	.47	.44	.42	.39

6. Compare the corrected coupling burst pressure rating to required system burst pressure.
 Coupling burst pressure rating = **210 psig** (14.47 bar) (Corrected for Material and Temperature). Required system burst pressure = **200 psig** (13.78 bar). The coupling is capable of withstanding the required burst pressure and the retainer cross-section is good.
7. Pick coupling and latch style part number per page 8.

General Purpose

How to Order -- See pg 8

Dimensions: **inches in boldface**
mm in lightface

V-Retainer Cross Sections

Retainer 1

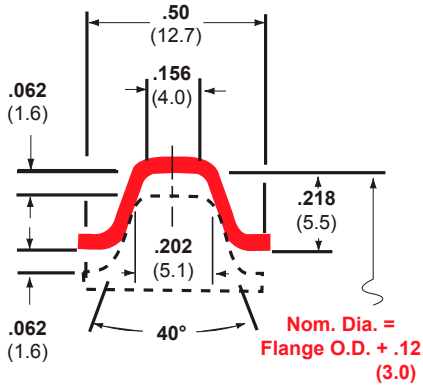

Retainer Thickness: **.032 in.** (.81 mm)

Retainer 2

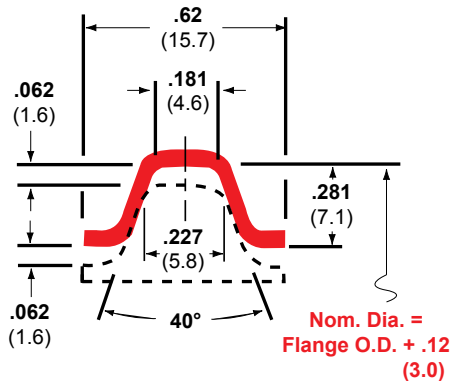

Retainer Thickness: **.040 in.** (1.02 mm)

Retainer 3

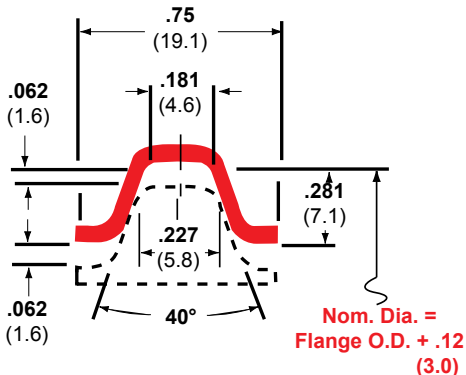

Retainer Thickness: **.080 in.** (2.01mm)

Coupling Style	Basic Part Number	Bolt Size	Min. Nom. Dia.	Band Width & Thickness
1	MV82751	10-24	4.00 101.6	.62 X .025 15.8 X.64
2	MV82652	10-24	1.75 44.5	.62 X .025 15.8 X.64
3	MV82653	10-24	1.75 44.5	.62 X .025 15.8 X.64
4	MV82734	10-24	4.50 114.3	.62 X .025 15.8 X.64
5	MV82795	10-24	6.00 152.4	.62 X .025 15.8 X.64
7	MV87017	10-24	4.50 114.3	.62 X .025 15.8 X.64
8	MV88018	10-24	1.75 44.5	.62 X .025 15.8 X.64
1	MV83571	¼ - 20	6.00 152.4	.75 X .032 19.1 X .81
2	MV83522	¼ - 20	2.00 50.8	.75 X .032 19.1 X .81
3	MV83523	¼ - 20	3.00 76.2	.75 X .032 19.1 X .81
4	MV83564	¼ - 20	5.00 127.0	.75 X .032 19.1 X .81
5	MV83595	¼ - 20	6.00 152.4	.75 X .032 19.1 X .81
7	MV87097	¼ - 20	6.00 152.4	.75 X .032 19.1 X .81
8	MV88098	¼ - 20	2.00 50.8	.75 X .032 19.1 X .81
2	MV83152	¼ - 20	3.00 76.2	.88 X .063 22.4 X 1.60
3	MV83153	¼ - 20	3.00 76.2	.88 X .063 22.4 X 1.60
4	MV83194	¼ - 20	6.00 152.4	.88 X .063 22.4 X 1.60
7	MV87107	¼ - 20	6.00 152.4	.88 X .063 22.4 X 1.60
8	MV88108	¼ - 20	3.00 76.2	.88 X .063 22.4 X 1.60

Coupling Burst Pressure Rating at **+70°F (+21.1 °C)**
Material: 301 stainless steel
Coupling burst pressures are shown in the performance charts instead of operating pressures since the safety factor over operating conditions might vary with each application. Coupling burst pressure ratings are based on static internal pressure. See Table 2 on page 45 for correction factors to use for other materials and elevated temperatures. For sizes other than those listed, consult factory.

CAUTION: SYSTEM PRESSURE MUST BE RELEASED BEFORE UNFASTENING COUPLING.

— Coupling styles 1, 5, and 7
— All other coupling styles

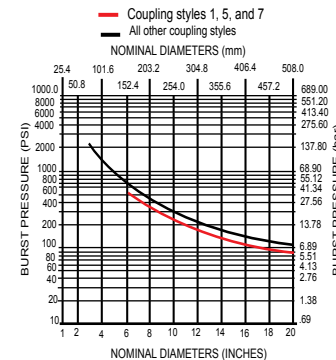
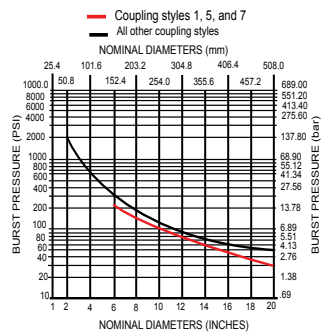
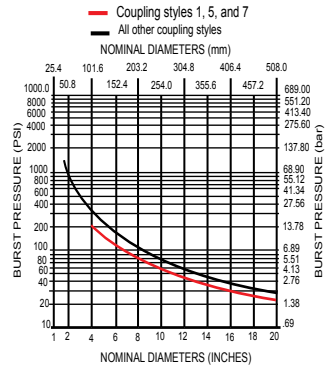

How to Order -- See pg 8

Dimensions: **inches** in boldface
mm in lightface

Coupling Burst Pressure Rating at +70°F (+21.1 °C)
Material: 301 stainless steel
Coupling burst pressures are shown in the performance charts instead of operating pressures since the safety factor over operating conditions might vary with each application. Coupling burst pressure ratings are based on static internal pressure. See Table 2 on page 45 for correction factors to use for other materials and elevated temperatures. For sizes other than those listed, consult factory

CAUTION: SYSTEM PRESSURE MUST BE RELEASED BEFORE UNFASTENING COUPLING.

— Coupling styles 1, 5, and 7
— All other coupling styles

V-Retainer Cross Sections

Retainer 4

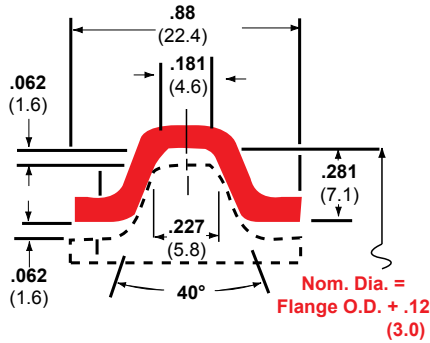

Retainer Thickness: **.090 in.** (2.29mm)

Retainer 5

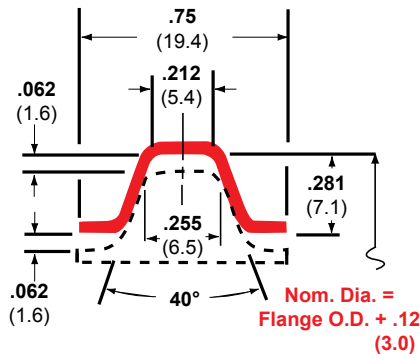

Retainer Thickness: **.04 in.** (1.02 mm)

Retainer 6

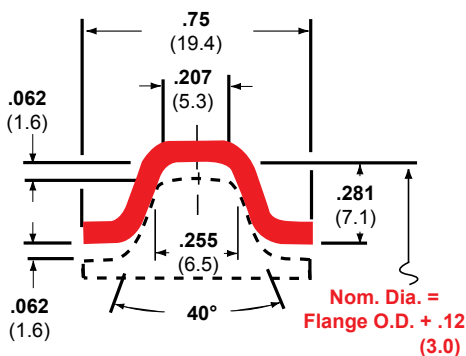

Retainer Thickness: **.063 in.** (1.6 mm)

Coupling Style	Basic Part Number	Bolt Size	Min. Nom. Dia.	Band Width & Thickness
2	MV83102	3/8-16	6.00 152.4	1.25 x .063 31.8 1.60
4	MV83134	3/8-16	10.00 254	1.25 x .063 31.8 1.60
1	MV84581	1/4-20	6.00 152.4	.75 X .032 19.1 X .81
2	MV83652	1/4-20	1.75 44.5	.75 X .032 19.1 X .81
3	MV83653	1/4-20	3.00 76.2	.75 X .032 19.1 X .81
4	MV84594	1/4-20	5.00 127.0	.75 X .032 19.1 X .81
7	MV87127	1/4-20	6.00 152.4	.75 X .032 19.1 X .81
8	MV88128	1/4-20	1.75 44.5	.75 X .032 19.1 X .81
1	MV84701	1/4-20	6.50 165.1	.75 X .040 19.1 X 1.02
2	MV84682	1/4-20	1.85 47.0	.75 X .040 19.1 X 1.02
3	MV85643	1/4-20	3.00 76.2	.75 X .040 19.1 X 1.02
4	MV84754	1/4-20	5.00 127.00	.75 X .040 19.1 X 1.02
5	MV84725	1/4-20	6.00 152.4	.75 X .040 19.1 X 1.02
6	MV85846	1/4-20	6.00 152.4	.75 X .040 19.1 X 1.02
7	MV87137	1/4-20	8.00 203.2	.75 X .040 19.1 X 1.02
8	MV88138	1/4-20	1.85 152.4	.75 X .040 19.1 X 1.02

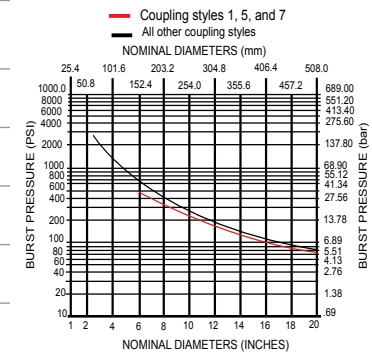
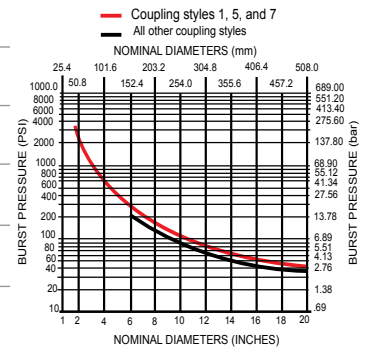
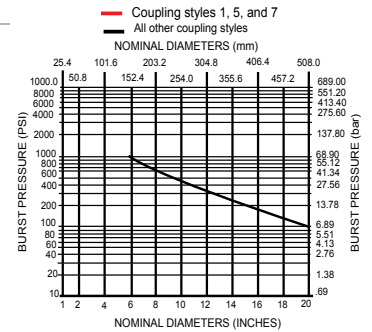

How to Order -- See pg 8

Dimensions: **inches** in boldface
mm in lightface

V-Retainer Cross Sections Retainer 7

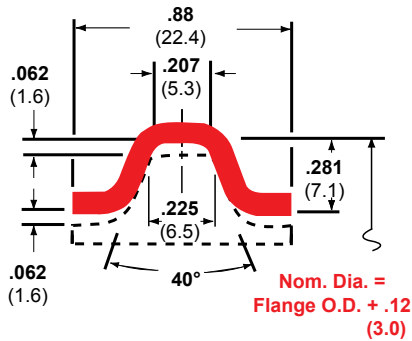

Retainer Thickness: **.080 in.** (2.03 mm)
.090 in. (2.29 mm) with C or Z material

Retainer 8

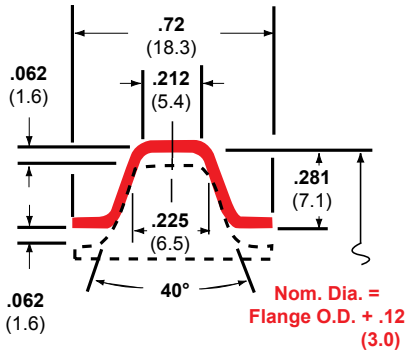

Retainer Thickness: **.050 in.** (1.27 mm)

Retainer 9

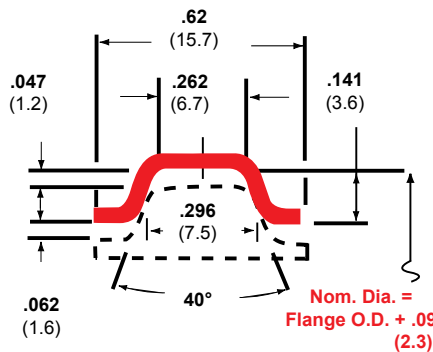

Retainer Thickness: **.050 in.** (1.6 mm)

Coupling Style	Basic Part Number	Bolt Size	Min. Nom. Dia.	Band Width & Thickness
3	MV85653	5/16 - 18	3.34 84.8	.88 x .063 22.4 X 1.60
4	MV84764	5/16 - 18	6.00 152.4	.88 x .063 22.4 X 1.60
5	MV84735	5/16 - 18	8.00 203.2	.88 x .063 22.4 X 1.60
6	MV85856	5/16 - 18	6.00 152.4	.88 x .063 22.4 X 1.60
1	MV83731	1/4 - 20	4.00 101.6	.75 X .032 19.1 X .81
2	MV83682	1/4 - 20	1.75 44.5	.75 X .032 19.1 X .81
3	MV85633	1/4 - 20	3.00 76.2	.75 X .032 19.1 X .81
4	MV83724	1/4 - 20	5.00 127.0	.75 X .032 19.1 X .81
6	MV85836	1/4 - 20	6.00 152.4	.75 X .032 19.1 X .81
7	MV87147	1/4 - 20	6.00 152.4	.75 X .040 19.1 X 1.02
8	MV88148	1/4 - 20	1.75 44.5	.75 X .040 19.1 X 1.02
1	MV84091	1/4 - 20	4.00 101.6	.75 X .032 19.1 X .81
2	MV84042	1/4 - 20	1.75 44.5	.75 X .032 19.1 X .81
3	MV84043	1/4 - 20	3.00 76.2	.75 X .032 19.1 X .81
4	MV84034	1/4 - 20	5.00 127.0	.75 X .032 19.1 X .81
7	MV87157	1/4 - 20	4.50 114.3	.75 X .032 19.1 X .81
8	MV88158	1/4 - 20	1.75 44.5	.75 X .032 19.1 X .81

Coupling Burst Pressure Rating at **+70°F** (+21.1 °C)
Material: 301 stainless steel
Coupling burst pressures are shown in the performance charts instead of operating pressures since the safety factor over operating conditions might vary with each application. Coupling burst pressure ratings are based on static internal pressure. See Table 2 on page 45 for correction factors to use for other materials and elevated temperatures. For sizes other than those listed, consult factory

CAUTION: SYSTEM PRESSURE MUST BE RELEASED BEFORE UNFASTENING COUPLING.

— Coupling styles 1, 5, and 7
— All other coupling styles

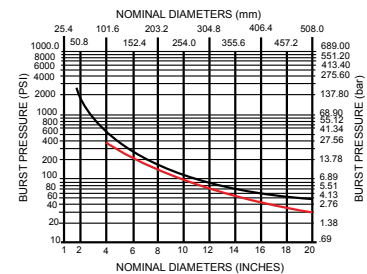
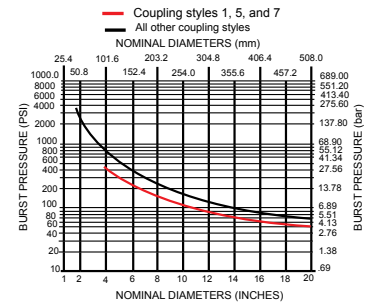
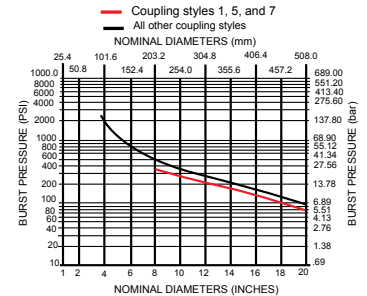

How to Order -- See pg 8

Dimensions: **inches** in boldface
mm in lightface

Coupling Burst Pressure Rating at **+70°F** (+21.1 °C)
Material: 301 stainless steel
Coupling burst pressures are shown in the performance charts instead of operating pressures since the safety factor over operating conditions might vary with each application. Coupling burst pressure ratings are based on static internal pressure. See Table 2 on page 45 for correction factors to use for other materials and elevated temperatures. For sizes other than those listed, consult factory

CAUTION: SYSTEM PRESSURE MUST BE RELEASED BEFORE UNFASTENING COUPLING.

— Coupling styles 1, 5, and 7
— All other coupling styles

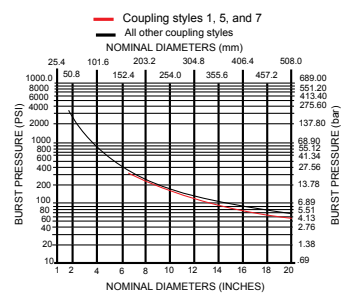
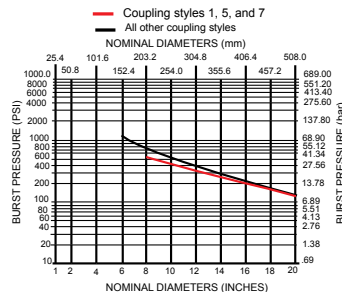
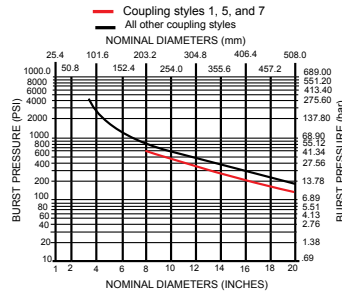

V-Retainer Cross Sections

Retainer 10

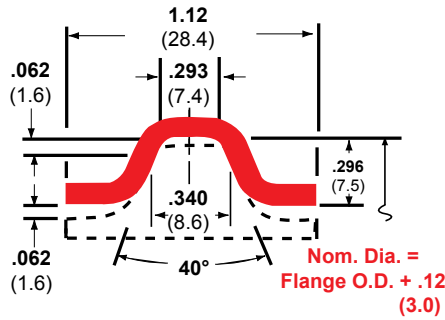

Retainer Thickness: **.090 in.** (2.29 mm)
.090 in. (2.29 mm) with C or Z material

Retainer 11

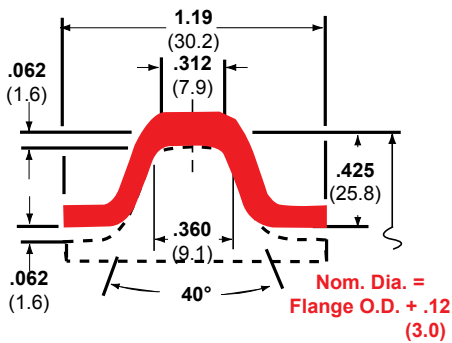

Retainer Thickness: **.090 in.** (2.29 mm)

Retainer 12

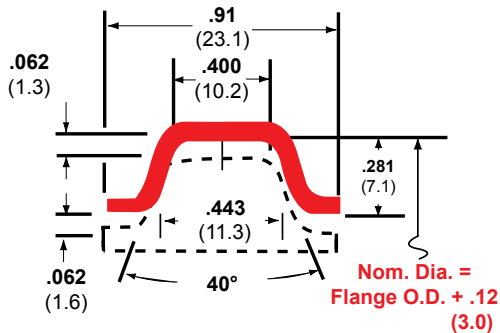

Retainer Thickness: **.050 in.** (1.27 mm)

Coupling Style	Basic Part Number	Bolt Size	Min. Nom. Dia.	Band Width & Thickness
2	MV86082	5/16 - 18	3.50 88.9	.88 x .063 22.4 X 1.60
3	MV86083	5/16 - 18	3.50 88.9	.88 x .063 22.4 X 1.60
4	MV86104	5/16 - 18	6.00 152.4	.88 x .063 22.4 X 1.60
5	MV86115	5/16 - 18	8.00 203.2	.88 x .063 22.4 X 1.60
2	MV86162	5/16 - 18	6.00 152.4	.88 X .063 22.4 X 1.60
3	MV86163	5/16 - 18	6.00 152.4	.88 X .063 22.4 X 1.60
4	MV86184	5/16 - 18	6.00 152.4	.88 X .063 22.4 X 1.60
5	MV86195	5/16 - 18	8.00 203.2	.88 X .063 22.4 X 1.60
1	MV84301	1/4 - 20	6.50 165.1	.75 X .040 19.1 X 1.02
2	MV84252	1/4 - 20	1.75 44.5	.75 X .040 19.1 X 1.02
3	MV85623	1/4 - 20	3.00 76.2	.75 X .040 19.1 X 1.02
4	MV84324	1/4 - 20	5.00 127.0	.75 X .040 19.1 X 1.02
6	MV85826	1/4 - 20	6.50 165.1	.75 X .040 19.1 X 1.02
7	MV87177	1/4 - 20	8.00 203.2	.75 X .040 19.1 X 1.02
8	MV88178	1/4 - 20	1.75 44.5	.75 X .040 19.1 X 1.02

How to Order -- See pg 8

Dimensions: **inches** in boldface
mm in lightface

V-Retainer Cross Sections

Retainer 13

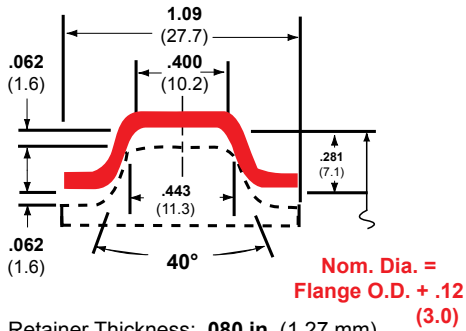

Retainer Thickness: **.080 in.** (1.27 mm)
.090 in (2.29 mm) with C or Z material

Retainer 14

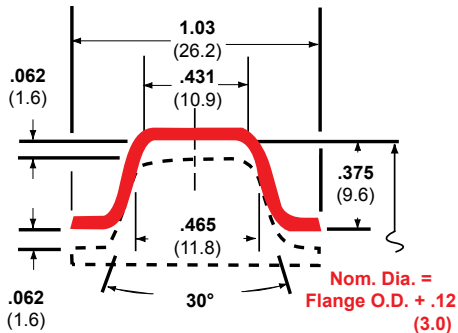

Retainer Thickness: **.040 in.** (1.02 mm)

Retainer 15

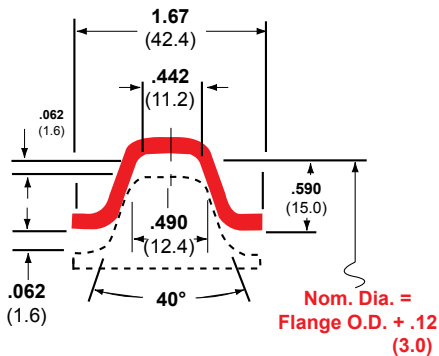

Retainer Thickness: **.125 in.** (3.18 mm)

Coupling Style	Basic Part Number	Bolt Size	Min. Nom. Dia.	Band Width & Thickness
2	MV86052	5/16 - 18	3.50 88.9	.88 x .063 22.4 X 1.60
3	MV85663	5/16 - 18	5.00 127.0	.88 x .063 22.4 X 1.60
4	MV86074	5/16 - 18	6.00 152.4	.88 x .063 22.4 X 1.60
6	MV85866	5/16 - 18	6.00 152.4	.88 x .063 22.4 X 1.60
1	MV81841	1/4 - 20	7.00 177.8	.75 X .032 19.1 X .81
2	MV81802	1/4 - 20	4.00 101.6	.75 X .032 19.1 X .81
4	MV81834	1/4 - 20	6.00 152.4	.75 X .032 19.1 X .81
5	MV81865	1/4 - 20	6.00 152.4	.75 X .032 19.1 X .81
8	MV88188	1/4 - 20	4.00 101.6	.75 X .032 19.1 X .81
2	MV86122	3/8 - 16	8.00 203.2	.75 X .032 19.1 X .81
3	MV86123	3/8 - 16	8.00 203.2	.75 X .032 19.1 X .81
4	MV86144	3/8 - 16	10.00 254.0	.75 X .032 19.1 X .81
5	MV86155	3/8 - 16	10.00 254.0	.75 X .032 19.1 X .81

Coupling Burst Pressure Rating at **+70°F** (+21.1 °C)
Material: 301 stainless steel
Coupling burst pressures are shown in the performance charts instead of operating pressures since the safety factor over operating conditions might vary with each application. Coupling burst pressure ratings are based on static internal pressure. See Table 2 on page 45 for correction factors to use for other materials and elevated temperatures. For sizes other than those listed, consult factory

CAUTION: SYSTEM PRESSURE MUST BE RELEASED BEFORE UNFASTENING COUPLING.

— Coupling styles 1, 5, and 7
— All other coupling styles

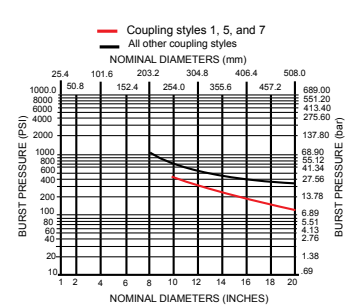
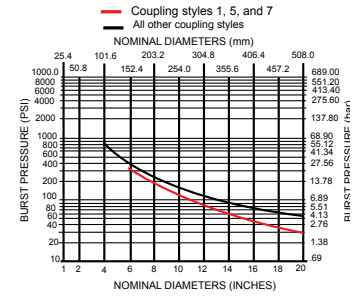
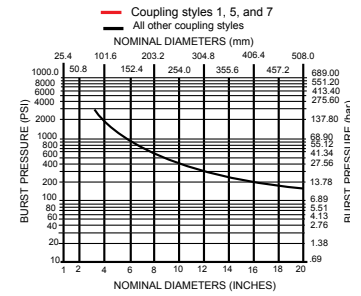

How to Order -- See pg 8

Dimensions: **inches** in boldface
mm in lightface

Coupling Burst Pressure Rating at **+70°F** (+21.1 °C)
Material: 301 stainless steel
Coupling burst pressures are shown in the performance charts instead of operating pressures since the safety factor over operating conditions might vary with each application. Coupling burst pressure ratings are based on static internal pressure. See Table 2 on page 45 for correction factors to use for other materials and elevated temperatures. For sizes other than those listed, consult factory

CAUTION: SYSTEM PRESSURE MUST BE RELEASED BEFORE UNFASTENING COUPLING.

— Coupling styles 1, 5, and 7
— All other coupling styles

V-Retainer Cross Sections

Retainer 17

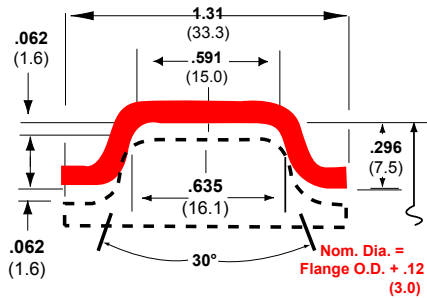

Retainer Thickness: **.090 in.** (2.39 mm)

Retainer 18

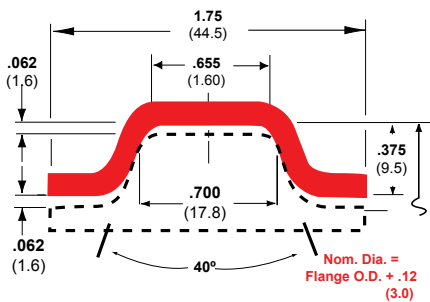

Retainer Thickness: **.125 in.** (3.18 mm)

Coupling Style	Basic Part Number	Bolt Size	Min. Nom. Dia.	Band Width & Thickness
2	MV86242	5/16-18	3.50 88.9	.88 x .063 22.4 X 1.60
3	MV86243	5/16-18	3.50 88.9	.88 x .063 22.4 X 1.60
4	MV86264	5/16-18	6.00 152.4	.88 x .063 22.4 X 1.60
5	MV86275	5/16-18	8.00 203.2	.88 x .063 22.4 X 1.60
6	MV86276	5/16-18	6.50 165.1	.88 x .063 22.4 X 1.60
2	MV86282	3/8-16	8.00 203.2	1.25 X .063 31.8 X 1.60
3	MV86283	3/8-16	8.00 203.2	1.25 X .063 31.8 X 1.60
4	MV86304	3/8-16	10.00 254.0	1.25 X .063 31.8 X 1.60
5	MV86315	3/8-16	10.00 254.0	1.25 X .063 31.8 X 1.60
6	MV86316	3/8-16	10.00 254.0	1.25 X .063 31.8 X 1.60

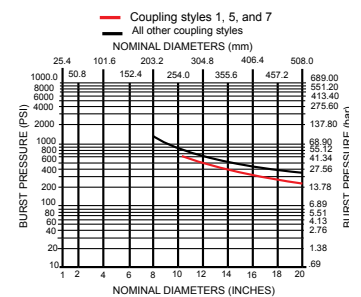
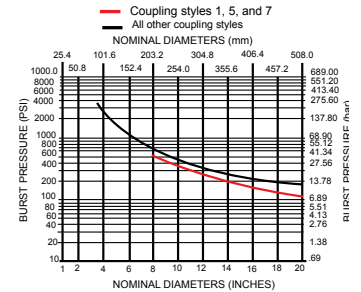

Servicemaster™ Couplings and Flanges

The Servicemaster is a gasketless connection for pneumatic and exhaust lines, tank cover assemblies, etc. The coupling installs quickly and easily with only one bolt to tighten. Because it is gasketless, the Servicemaster flanges are not recommended for use in closed compartments or areas where leakage could be hazardous to personnel.

CAUTION: SYSTEM PRESSURE MUST BE RELEASED BEFORE UNFASTENING COUPLING.

Coupling Burst Pressure Ratings at +70°F (+21.1° C)

Coupling burst pressures are shown in the performance charts instead of operating pressures since the safety factor over operating conditions might vary with each application. Coupling burst pressure ratings are based on static internal pressure.

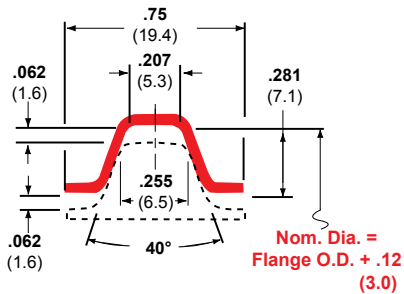
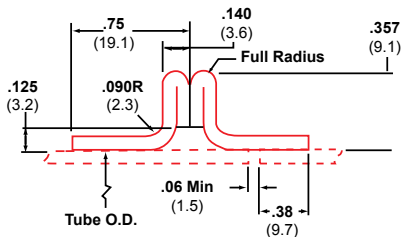
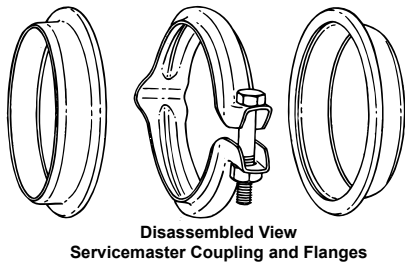

Joint Burst Pressure

— 300 Series Stainless Steel
 Carbon Steel

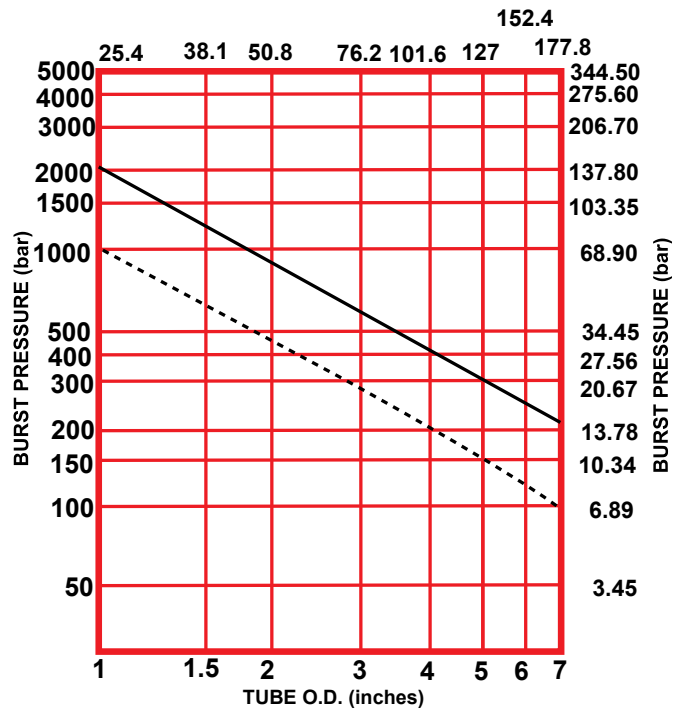

Dimensions: **inches** in **boldface**
mm in lightface

Servicemaster Flange and Couplings

Tube O.D.	Servicemaster Flange Part number	55000-Servicemaster Coupling* Part Number	Coupling Nominal Diameter
1.00 25.4	MFF61196-100X	55000-100X	1.79 45.5
1.25 31.8	MFF61196-125X	55000-125X	2.04 51.8
1.5 38.1	MFF61196-150X	55000-150X	2.29 58.2
1.75 44.5	MFF61196-175X	55000-175X	2.54 64.5
2.00 50.8	MFF61196-200X	55000-200X	2.81 71.4
2.25 57.2	MFF61196-225X	55000-225X	3.06 77.7
2.5 63.5	MFF61196-250X	55000-250X	3.34 84.8
2.75 69.9	MFF61196-275X	55000-275X	3.59 91.2
3.00 76.2	MFF61196-300X	55000-300X	3.84 97.5
3.50 88.9	MFF61196-350X	55000-350X	4.34 110.2
4.00 101.6	MFF61196-400X	55000-400X	4.84 122.9
4.50 114.3	MFF61196-450X	55000-450X	5.34 135.6
5.00 127	MFF61196-500X	55000-55000-500X	5.84 148.3
5.50 139.7	MFF61196-550X	55000-550X	6.34 161.0
6.00 152.4	MFF61196-600X	55000-600X	6.84 173.7

Example of Part Number for Ordering

Flange **MFF61196-000 X**

Basic Part No. _____

Tube O.D. Tabulated _____

Material Code _____

Material Code _____

C = Carbon Steel
S = 321 Stainless Steel

Servicemaster Coupling **55000-000 X**

Basic Part No. _____

Tube O.D. Tabulated _____

Material Code _____

Material Code _____

C = Carbon Steel
S = 321 Stainless Steel
Z = Plated Carbon Steel

*For tube O.D. less than **2.25 in.** (57.2) bolt size is ¼–20
For tube O.D. **2.25 in.** (57.2 mm) and over bolt size is 5/16–18

Basic Part Number MVT80009

Use to connect filter units, hydraulic accumulators, and for household appliance components

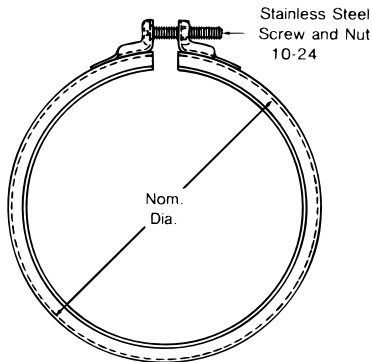

Latch Style A
Not available in Nom. Dia. less than 4.50 in. (114.3 mm).

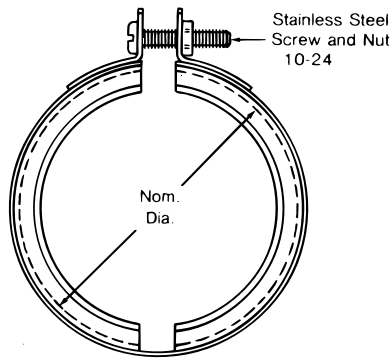

Latch Style B
Two retainer segments for Nom. Dia. less than 4.50 in. (114.3 mm).

Coupling Burst Pressure Rating at **+70°F** (+21.1 °C)
Material: 301 stainless steel
Coupling burst pressures are shown in the performance charts instead of operating pressures since the safety factor over operating conditions might vary with each application. Coupling burst pressure ratings are based on static internal pressure. See Table 2 on page 45 for correction factors to use for other materials and elevated temperatures. For sizes other than those listed, consult factory

CAUTION: SYSTEM PRESSURE MUST BE RELEASED BEFORE UNFASTENING COUPLING.

— Coupling styles 1, 5, and 7
— All other coupling styles

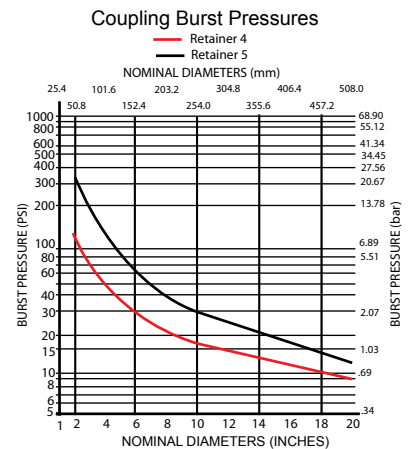

Example of Part Number for Ordering

MV80009 A 4 S 500

Basic Part No. _____
Latch Style A or B _____
Retainer No. _____
Material Code _____
Material Code
 S = 301 Stainless Steel
Nom. Dia. (100 = 1 inch) _____

V-Retainer Cross Sections

Retainer 2
Min. Nom. Dia.: 2.00 in (50.8 mm)

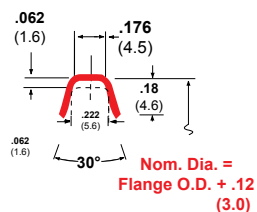

Retainer Thickness:
.025in. (.81 mm)
.040 in. (1.02 mm) on dia. under 4.00 in. (101.6 mm)

Retainer 3
Min. Nom. Dia.: 2.00 in. (50.8 mm)

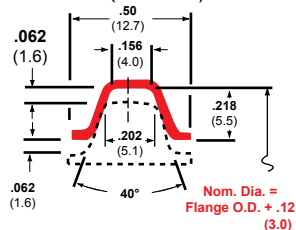

Retainer Thickness:
.032in. (.81 mm)

Retainer 4
Min. Nom. Dia.: 2.00 in. (50.8 mm)

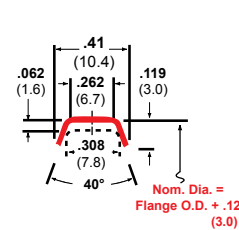

Retainer Thickness:
.032in. (.81 mm)

Retainer 5
Min. Nom. Dia.: 2.00 in (50.8 mm)

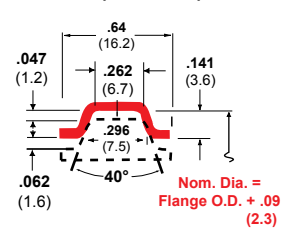

Retainer Thickness:
.032 in. (.81 mm)

Basic Part Number

MVT89019B

Min. Nom. Dia.: **2.81 in.** (71.4 mm)
 Max Nom. Dia.: **5.50 in.** (139.7 mm)

MVT89099B

Min. Nom Dia: **5.50 in.** (139.7 mm)
 Max. Num. Dia.: **24.00 in.** (609.6 mm)

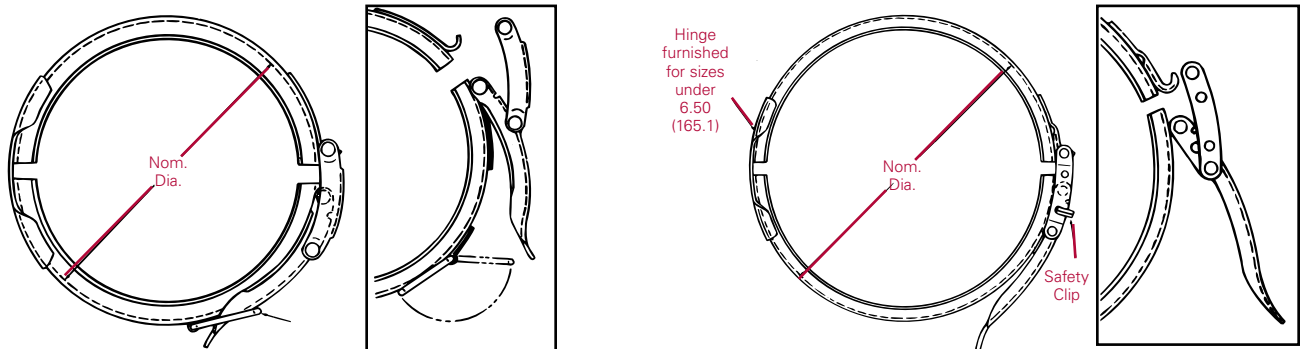

With quick opening over center latches, these couplings can be used wherever applications require frequent assembly and disassembly. A safety device is furnished on these couplings to prevent inadvertent opening of the over center latch while the system is pressurized.

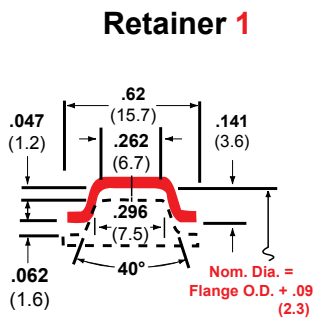

Retainer Thickness:
.050 in. (1.27 mm)

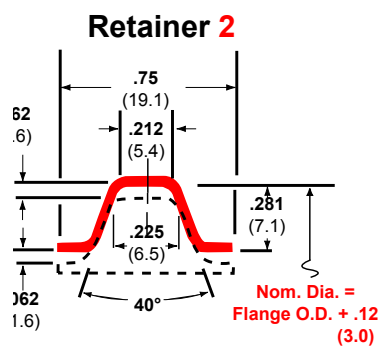

Retainer Thickness:
.040 in. (1.02 mm)

Coupling Burst Pressure Rating at **+70°F** (+21.1° C)
 Material: 301 stainless steel
 Coupling burst pressures are shown in the performance charts instead of operating pressures since the safety factor over operating conditions might vary with each application. Coupling burst pressure ratings are based on static internal pressure. See Table 2 on page 45 for correction factors to use for other materials and elevated temperatures. For sizes other than those listed, consult factory.

CAUTION: SYSTEM PRESSURE MUST BE RELEASED BEFORE UNFASTENING COUPLING.

Coupling Burst Pressures

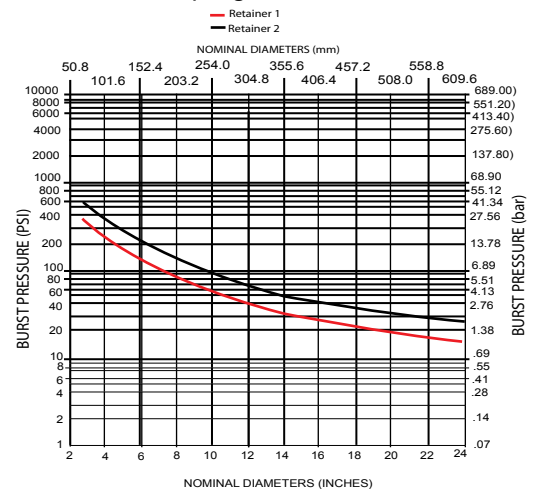

Example of Part Number for Ordering

MV89099B 2 S 550

Basic Part No. _____

Retainer No. _____

Material Code _____

Nom. Dia. (100 = 1 inch) _____

Material Code

S = Stainless Steel

Basic Part Number

MV89079

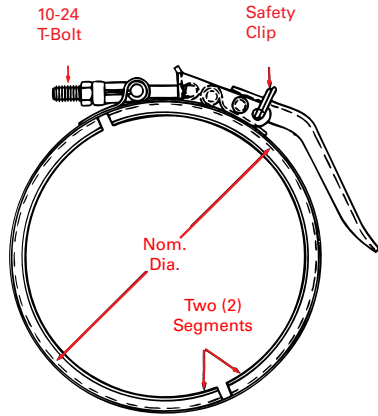

Min. Nom. Dia.: **2.81 in.** (71.4 mm)
 Except Retainer No. 6 which is **3.25 in.** (82.6 mm)
 Max. Nom. Dia.: **50.00 in.** (1270.00 mm)

Example of Part Number for Ordering

MV89079- 4 S 1000 V

Basic Part No. _____

Retainer No. _____

Material Code _____

S= 301 Stainless Steel Band and Retainer,
 316 Stainless Steel T-Bolt

Nom. Dia. (100 = 1 inch) _____

Nut Code: _____

C = Plated Steel Hex Nut
 F = Plated Steel Fiber Insert Hex Locknut
 T = Stainless Steel Hex Nut
 V = Stainless Steel All Metal Hex Locknut

Coupling Burst Pressures at **+70°F** (21.1° C)
 Material: 301 stainless steel
 Coupling burst pressures are shown in the performance charts instead of operating pressures since the safety factor over operating conditions might vary with each application. Coupling burst pressure ratings are based on static internal pressure. See Table 2 on page 45 for correction factors to use for elevated temperatures. For sizes other than those listed, consult factory.

CAUTION: SYSTEM PRESSURE MUST BE RELEASED BEFORE UNFASTENING COUPLING.

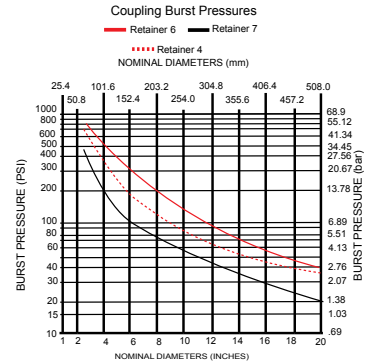
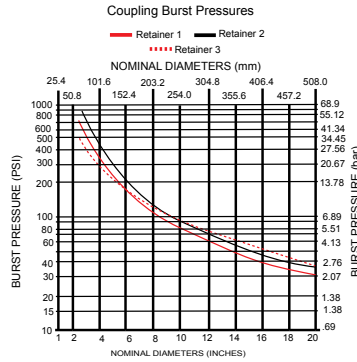

V-Retainer Cross Sections

Retainer 1

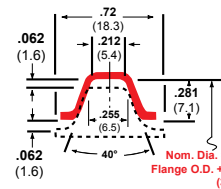

Retainer Thickness:
.050 in. (1.27 mm)

Retainer 2

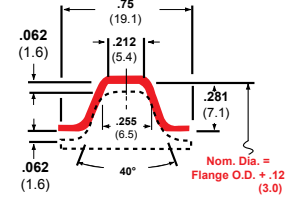

Retainer Thickness:
.040 in. (1.02 mm)

Retainer 3

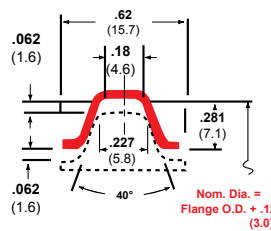

Retainer Thickness:
.040 in. (1.02 mm)

Retainer 4 and 7

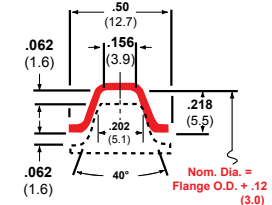

Retainer Thickness:
.032 in. (.81 mm) for Retainer 4
.050 in. (1.27 mm) for Retainer 7

Retainer 5

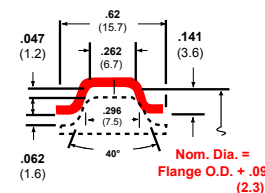

Retainer Thickness:
.050 in. (1.27 mm)

Retainer 6

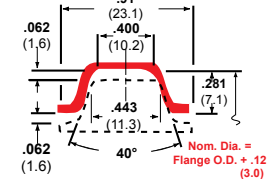

Retainer Thickness:
.050 in. (1.27 mm)

Band Width and Thickness:
 .62 X .020 (15.74 X .51) for S material

Basic Part Number MVT89029

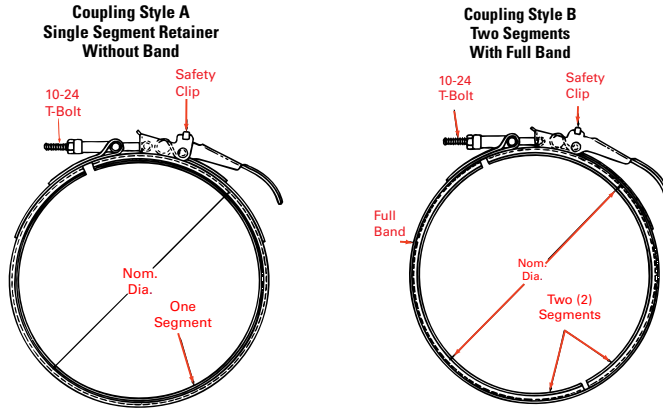

Min. Nom. Dia.:
 Style A **6.50 in.** (165.1 mm)
 Style B **5.50 in.** (139.7 mm)
 Max. Nom. Dia.: **50.00 in.** (1270.00 mm)

Coupling Burst Pressures at +70°F (21.1°C)

Material: 301 stainless steel

Coupling burst pressures are shown in the performance charts instead of operating pressures since the safety factor over operating conditions might vary with each application. Coupling burst pressures are based on static internal pressure.

CAUTION: SYSTEM PRESSURE MUST BE RELEASED BEFORE UNFASTENING COUPLING.

See Table 2 on page 45 for correction factors to use for other materials and elevated temperatures. For sizes other than those listed, consult factory. Reduce chart values by 20% for Coupling Style "A."

CAUTION: SYSTEM PRESSURE MUST BE RELEASED BEFORE UNFASTENING COUPLING.

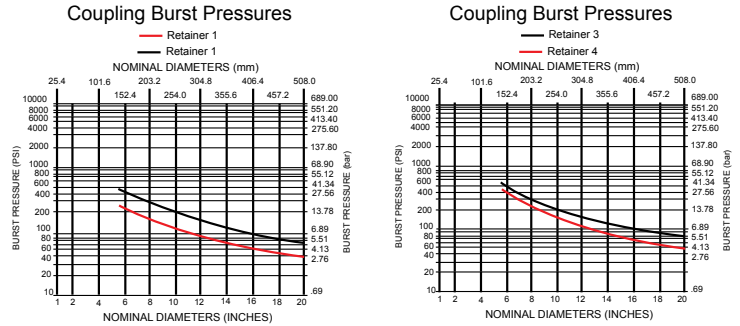

Example of Part Number for Ordering

MVT89029 A 4 S 1000 V

Basic Part No. _____

Coupling Style (A or B) _____

Retainer No. _____

Material Code _____

Nom. Dia. (100 = 1 inch) _____

Nut Code _____

Material Code

S = 301 Stainless Steel Band and Retainer,
 316 Stainless Steel T-Bolt

Nut Code:

C = Plated Steel Hex Nut
 F = Plated Steel Fiber Insert Hex Locknut
 T = Stainless Steel Hex Nut
 V = Stainless Steel All Metal Hex Locknut

V-Retainer Cross Sections

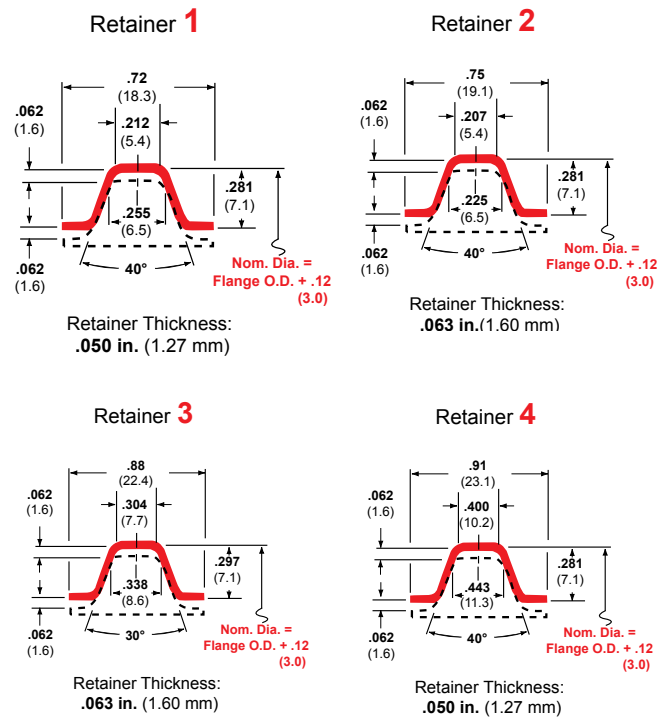

Band Width and Thickness

.88 x .032 (22.40 x .81) for S material

Basic Part Number MVT89039

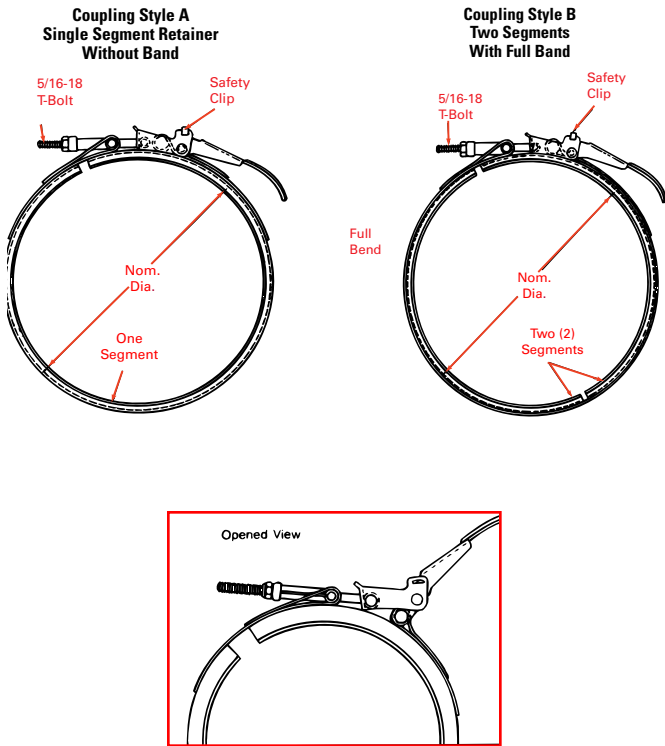

Coupling Burst Pressure Rating at +70°F (+21.1° C)

Material: 301 stainless steel

Coupling burst pressures are shown in the performance charts instead of operating pressures since the safety factor over operating conditions might vary with each application. Coupling burst pressures are based on static internal pressure.

See Table 2 on page 45 for correction factors to use for other materials and elevated temperatures. For sizes other than those listed, consult factory.

CAUTION: SYSTEM PRESSURE MUST BE RELEASED BEFORE UNFASTENING COUPLING.

See page 23 for example of part number for ordering. For other retainers than those listed, contact Aeroquip.

Reduce chart values by 20% for Coupling Style "A."

Coupling Burst Pressures

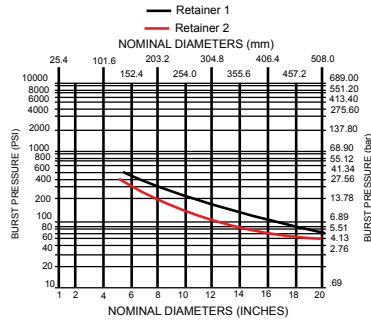

Coupling Burst Pressures

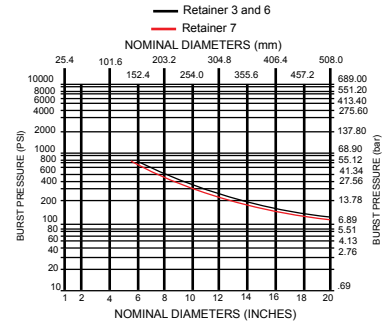

Style "A" Min. Nom. Dia.: **8.50 in.** (215.9 mm)
 Style "B" Min. Nom. Dia.: **5.50 in.** (139.7 mm)
 Max Nom. Dia.: **50.00 in.** (1270.0 mm)

V-Retainer Cross Sections

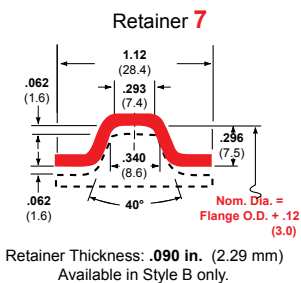
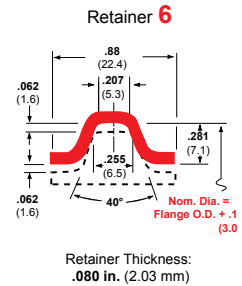
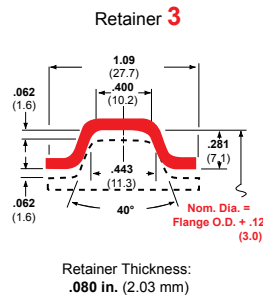
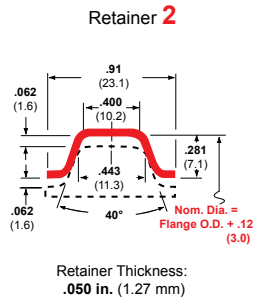
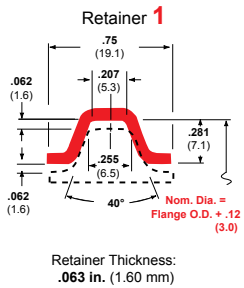

Band Width and Thickness: **.88 x .050** (22.40 x 1.27) for S material

Section Index	Page
Machined Flanges	28
Schedule 40 Pipe	29
Flange Selection Chart	27
Selection Guide	26
Tube	29

Flange Selection Guide

- Determine the following requirements: system burst pressure, operating temperature, environmental condition, pipe or tube O.D., type of gasket required (O-ring, flat gasket, metal to metal, etc.) and flange material.
- Select style of flanges which fits the application.
- Determine the flange burst pressure rating, using tube diameter (tube or pipe O.D.) and graph relating to specific style of flange being considered.
- Correct for temperature and material changes. If an elevated temperature is required, or if a different material other than 301 stainless steel is to be used, multiply the flange burst pressure rating by the correction factor found in Table 1 below.
- Compare flange burst pressure rating to system burst pressure required.
 - If required system burst pressure is less than the rated flange burst pressure, the flange will do the job.
 - If required system burst pressure is higher than rated flange burst pressure, consider another flange style. Required system burst pressure must be less than the rated flange burst pressure.
- Determine part number.
- Determine proper coupling for use over flange.
 - Refer to Flange Selection Chart, page 27.
 - Find flange styles at top of chart.
 - Select coupling style to fit application. Right of chart.
 - Reference coupling or retainer number and page number.
 - Referring to proper page and retainer number, compare required system burst pressure to rated coupling system burst pressure as stipulated under Coupling Selection Procedure, pages 9-11.

Example:

- Requirements:
 - System burst pressure = **170 psig**
 - Operating temperature = **70°F**
 - Tube O.D. = **15 in.**
 - Type of gasket required: O-ring
 - 321 stainless steel material is required.

- Select style of flange.
- Flange burst pressure rating, referring to machined flange burst pressure graph on page 28 for the 56401 using **Tube Dia.**, flange burst pressure = **180 psig**.
- Correct for temperature and material: (determine correction factor from Table 1 on page 45.)

Corrected burst pressure rating = flange burst pressure rating from graph X correction factor.

Corrected burst pressure rating = 180 psig x 1 = 180 psig.

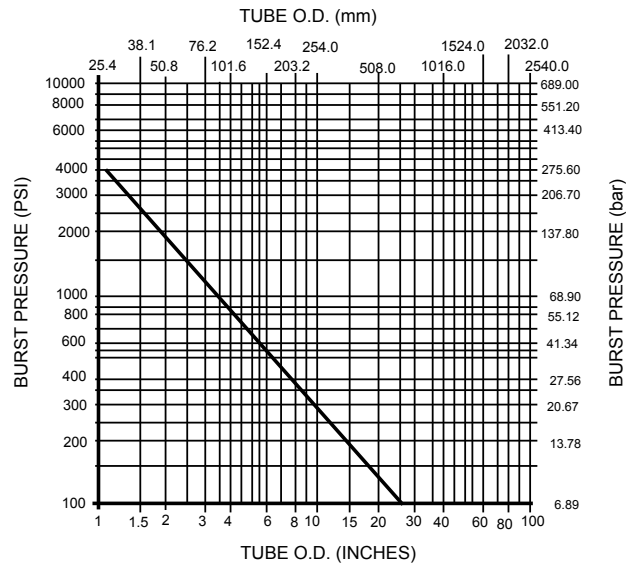

- Compare flange burst pressure rating with required burst pressure:
 - Flange burst pressure rating = 180 psig
 - Required system burst pressure rating = 170 psig
 - The flange is capable of withstanding the required burst pressure.
- P/N 56401-1500S
- To determine the proper coupling for use over flanges refer to Flange Selection Chart, page 27.

Table 1. Flange material and temperature correction chart

Material	+70°F (+21.1°C)	+200°F (+93.3°C)	+400°F (+204.4°C)	+600°F (+315.6°C)	+800°F (+426.7°C)
300 Series (Stainless Steel)	1.00	.88	.75	.68	.60
Carbon Steel	.67	.63	.59	.51	-
Aluminum	.50	.45	.26	-	-

This chart may be used to determine the correct flange to mate with V-Band Couplings shown in Section 1. If there is no flange shown in this catalog that is suitable for a specific application, contact Eaton for further information. When ordering flanges with diameters larger than those shown in this catalog, contact Eaton.

Service-master MFF61196	Machined Flange		Schedule 40 Pipe Flange		Tube Flange		Coupling Part No. or Retainer No.	Page No.	Coupling Style
	56400	56401	MFM5700	MFM5701	MFM5702	MFM5703			
X	X	X	X	X	X	X	5, 6	13	General Purpose
X	X	X	X	X	X	X	7, 8	14	
X							55000	18	Servicemaster
X	X	X	X	X	X	X	2	21	Non-Adjustable Over Center Latch
X	X	X	X	X	X	X	1, 2	23, 24	Adjustable Over Center Latch
							6	24	
X	X	X	X	X	X	X	1, 2	23, 24	
						X	4	23	
X	X	X	X	X	X	X	1, 6	24	
							2, 3	23, 24	

X Denotes that flange mates with coupling or retainer indicated

Basic Part Number

56400

Min. Tube O.D.: **1.00 in.** (25.4 mm)
 Max. Tube O.D.: **24.00 in.** (609.6 mm)

56401

Min. Tube O.D.: **1.00 in.** (25.4 mm)
 Max. Tube O.D.: **18.00 in.** (457.2 mm)

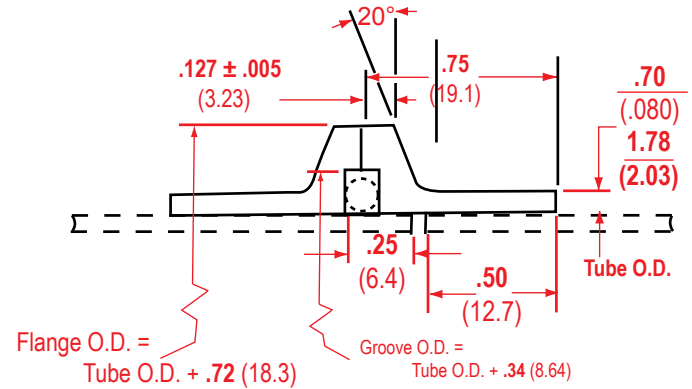
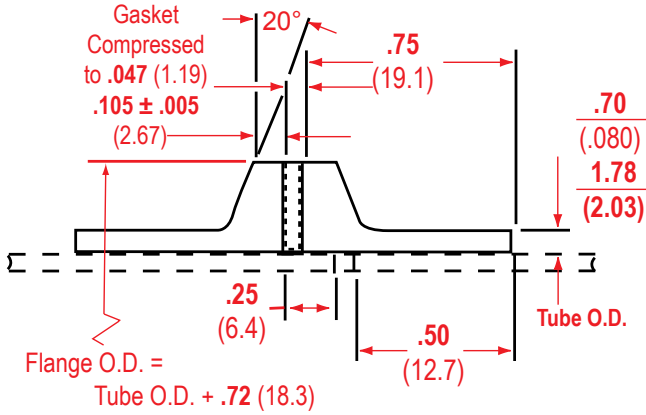

Gasketed Flat Faced Flanges

For High Temperature Applications

The flat gasket may be of mineral filled rubber or metal, or a combination of these materials. The gasket must compress to a **.047** minimum thickness for proper coupling assembly.

Recommended for pneumatic applications where some leakage is tolerable. Tube is used as a pilot for flange alignment and gasket support. Gaskets not supplied by Eaton.

O-Ring Sealed Flanges

The O-Ring gasket used may be of any rubber compound depending on the application. For larger sizes, standard O-Rings of the next smaller size than the flange cavity diameter may be purchased from your local source and stretched into position during assembly. The cavity area of the flanges has been designed to permit this. O-Rings not supplied by Eaton.

Example of Part Number for Ordering

56400-900 S

Basic Part No. _____

Tube O.D. (100 = 1 inch) _____

Material Code _____

Material Code

- A = Aluminum
- C = Carbon Steel
- J = 316 Stainless Steel
- S = 321 or 347 Stainless Steel

Machined Flange Burst Pressure Rating at +70°F (21.1° C)

Material: Stainless steel. Flange burst pressures are shown in the performance charts instead of operating pressures since the safety factor over operating conditions might vary with each application. Flange burst pressure ratings are based on static internal pressure.

See page 45 for correction factors to use for other materials and elevated temperatures.

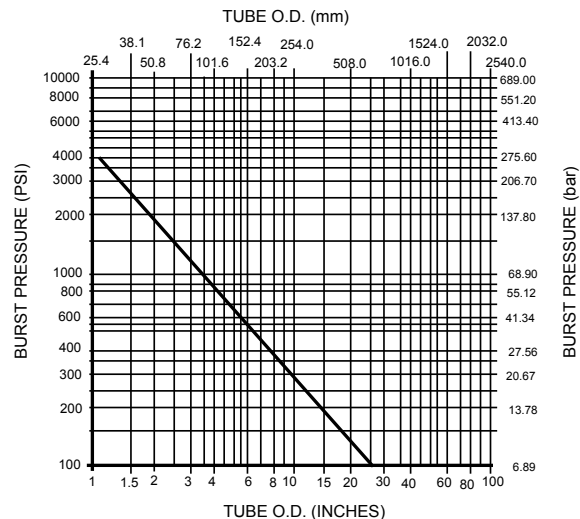
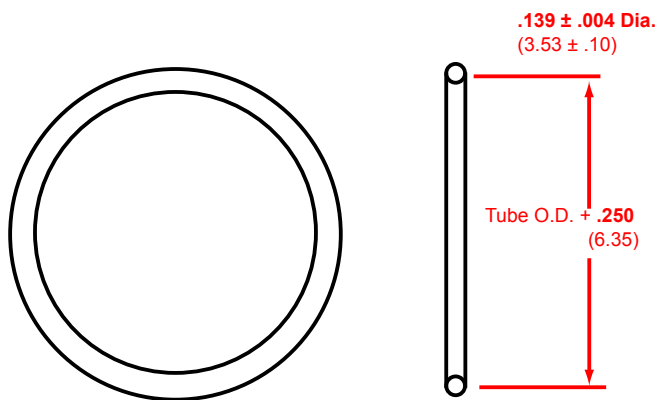

Schedule 40 Pipe

Basic Part Number
MFM5700

Basic Part Number
MFM5701

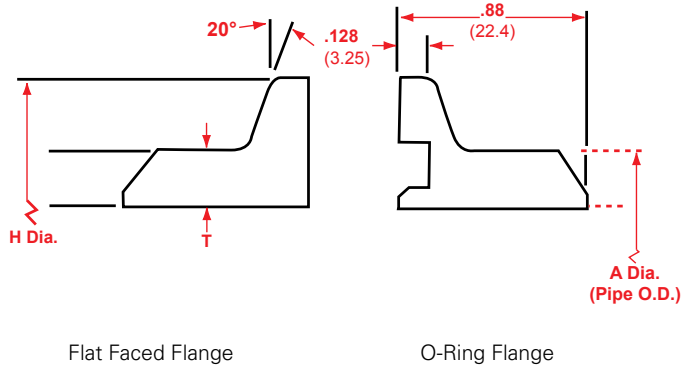

Dimensions: **inches in boldface**
mm in lightface

Pipe Size 100=1 inch	A Dia.	T	O-Ring Size Ref SAE J120	H. Dia. ± .015
100	1.32 33.5	.133 3.38	-219	1.88 47.8
125	1.66 42.1	.140 3.56	-223	2.22 56.4
150	1.90 48.2	.145 3.68	-225	2.46 62.5
200	2.38 60.1	.154 3.91	-229	2.94 74.7
250	2.88 73.2	.203 5.16	-232	3.44 87.4
300	3.50 88.9	.216 5.49	-237	4.06 103
350	4.00 102	.226 5.74	-241	4.56 116
400	4.50 114	.237 6.02	-245	5.06 129
500	5.56 141	.258 6.55	-254	6.12 155.4
600	6.62 168	.280 7.11	-260	7.19 183
800	8.62 219	.322 8.18	-268	9.19 233

TUBE

Basic Part Number
MFM5702

Basic Part Number
MFM5703

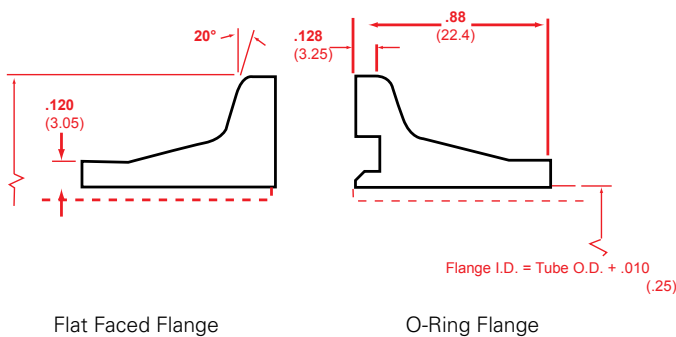

Dimensions: **inches in boldface**
mm in lightface

Tube Size 100=1 inch	H Dia. ± .015	O-Ring Size Ref SAE J120
100	1.88 47.8	-220
125	2.22 56.4	-224
150	2.46 62.5	-226
200	2.94 74.7	-230
250	3.44 87.4	-234
300	4.06 103	-236
350	4.56 116	-240
400	5.06 129	-244
500	6.12 155	-252
600	7.19 183	-259

Example of Part Number for Ordering

MFM5703 S 400

Basic Part No. _____

Material Code _____

Tube O.D. (100 = 1 inch) _____

Material Code
A = Aluminum
C = Carbon Steel
J = 316 Stainless Steel
S = 321 or 347 Stainless Steel

For cap flange, part number MFM5704 or MFM5705, contact Eaton.
For sizes not shown contact Eaton

Note: O-Rings are not supplied by Eaton

Applications



Telephone repeaters stay pressurized when assembled and sealed with V-Bands.



Coupling with one screw assemblies and seals pump, valves, motor and tank.



Klystron tube is water cooled; V-Bands keep water jacket tight but easily accessible for maintenance.



V-Band Couplings connect double diaphragm system with inlet and outlet piping.



Quick Coupler is excellent for frequent maintenance such as filter applications.



Dry sea instruments submerged over 20,000 feet stay dry inside. V-Bands assure the seal.



Interchangeable cheese molds clamp quickly onto this machine with Over Center Latch Coupling.

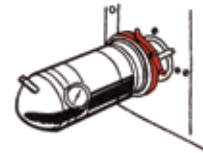

Cleanable mixing chamber for urethane foaming machine uses an Over Center Latch Coupling.

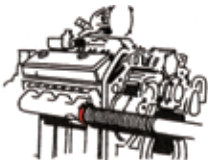

V-Band Couplings secure exhaust system to engine manifold.



The best way yet to mount a mufller; many line-haul rigs use an Eaton Support Clamp.



Strong and simple Lug Ear Coupling seals this spherical filter.



Central vacuum sweepers use motors assembled and sealed by a V-Band Coupling.



Motors assemble with uniform stresses when housings are joined with V-Band Couplings.



This precision instrument is sealed by a V-Band Coupling and supported by a Band Clamp assembly.



Strong seals, fast access for screen changes make these "sifters" the best.

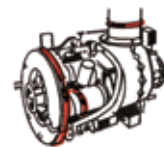

Stainless V-Band Couplings assemble gas turbine compressor, burners and exhaust duct.



Fog horns that stay dry – stay sold; V-Band Coupling retains and seals the plastic cover.



Dry cleaner solvent filter condensers use V-Band Couplings, benefiting cost and service.



Hermetically sealed compressor's 4 V-Band Couplings save bolts, machining and TIME!



V-Band Couplings allow easy cleaning of these chemical and oil tank breather valves.



This sprayer locks onto the canister with a flip of the Over Center Latch.



Transponder case is sealed with this square coupling and Over Center Latch.



No wrench is needed for this double-acting screw V-Band Coupling.

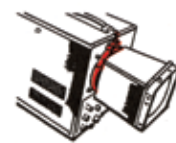

Oscilloscope "Expander" clamps onto CRT bezel with Over Center Latch Band Clamp.

Section Index	Page
Band Clamps	32 - 39
Adjustable	37
Adjustable Over Center Latch	38
Cradle Support	39
Heavy Duty	34
Multiple Take-up	33
Spring Loaded	35
T-Bolt	32
Universal	36
Utility	33
Band Straps	40 - 41

Basic Part Number

MB9325
MB9425
MB9525
MB9625

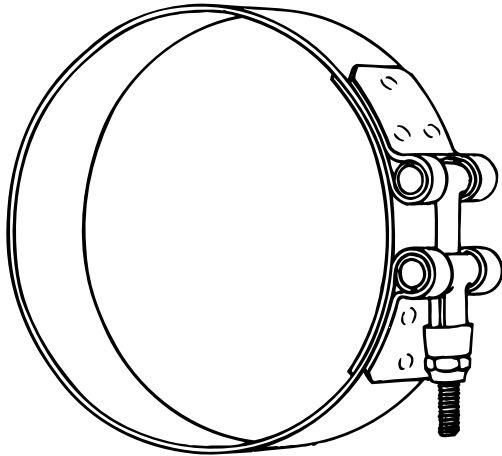

Latch Styles

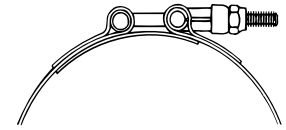

T-Bolt Latch
Latch Code T

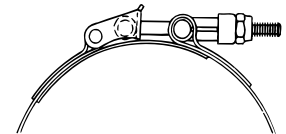

Quick Coupler Latch
Latch Code K

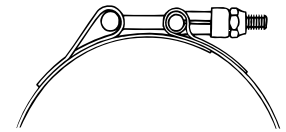

Quick Release
Saddle Latch
Latch Code L

Example of Part Number for Ordering

MB9325 K 100 S 600 V

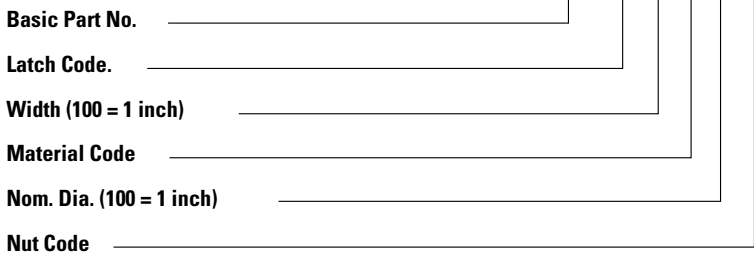

Nut Code:

- C** = Plated Steel Hex Nut
- F** = Plated Steel Fiber Insert Hex Locknut
- T** = Stainless Steel Hex Nut
- V** = Stainless Steel All Metal Hex Locknut



C



F



T



V

Basic Part Number	MB9325	MB9425	MB9525	MB9625
Bolt Size	10-24	¼-20	5/16-18	3/8-16
Minimum Nominal Diameter	1.25 31.8	1.50 38.1	4.5 114.3	6.00 152.4
Band Material & Thickness	.025 .64	.040 1.02	.063 1.60	.080 2.03
J=316 Stainless Steel, 316 Stainless Steel T=Bolt.				
S= Stainless Steel, 316 Stainless Steel Bolt	.020 .51	.025 .64	.050 1.27	.063 1.60
Band Widths	.52, .62, .75, 1.00, 13.2, 15.7, 19.1, 25.4	.75, .88, 1.00, 1.25, 19.1, 22.4, 25.4, 31.8	.88, 1.00, 1.25, 1.50, 22.4, 25.4, 31.8, 38.1	1.25, 1.50, 1.75, 2.00, 31.8, 38.1, 44.5, 50.8
Latch Code	T, K, or L	T, K, or L	T or K only	T or K only

Dimensions: **inches in boldface**
mm in lightface

Basic Part Number
MB9336
MB9446

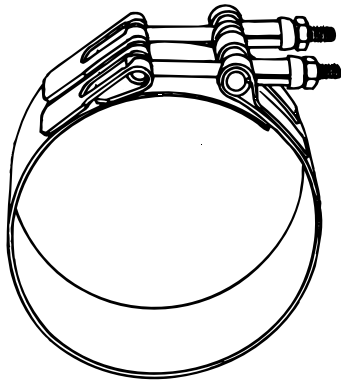

For clamping ducting connections which do not require the integrity of flanges. Can be used to join exhaust ducting.

Dimensions: **inches in boldface**
 mm in lightface

Basic Part Number	MB9336	MB9446
Bolt Size	10-24	¼-20
Band Material and Thickness J=316 Stainless Steel, 316 Stainless Steel T-Bolt	.032 .81	.032 .81
S=301 Stainless Steel 316 Stainless Steel T-Bolt	.025 .64	.025 .64
Band Width Range .25 in. increments 6.4 mm	1.75-6.00 44.5-152.4	2.00-6.00 50.80- 152.4
Latch Style	Quick Release Saddle	
Minimum Nominal Diameter	2.00 50.8	2.50 63.5

Example of Part Number for Ordering

MB9446 S 600T 800

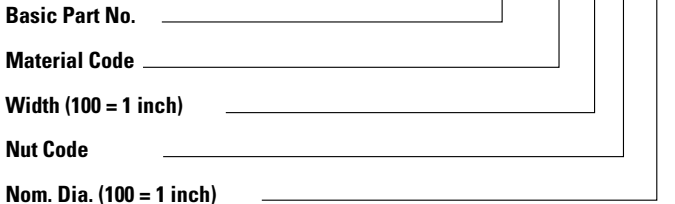

Nut Code:
C = Plated Steel HEX Nut
F = Plated Steel Fiber Insert Hex Locknut
T = Stainless Steel Hex nut
V = Stainless Steel All Metal Hex Locknut

Utility Band Clamp

Basic Part Number
MB9802

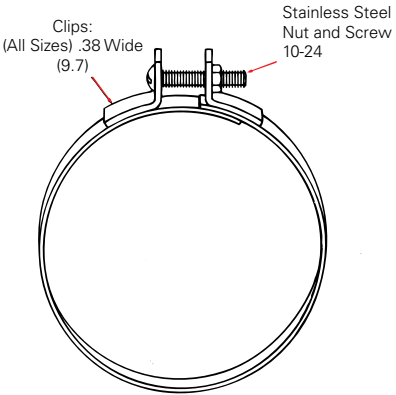

Utility band clamps are for use on applications such as thermal blankets. These clamps are for use on irregular shapes, too.

Dimensions: **inches in boldface**
 mm in lightface

Basic Part Number	MB9802
Screw: Nut Size	10-24
Material	Stainless Steel
Band Material and Thickness S=Stainless Steel	.020 .51
Band Width	.25, .38, .50, .62, .75 6.4, 9.7, 12.7, 15.8, 19.1
Minimum Nominal Diameter	.75 19.1

Example of Part Number for Ordering

MB9802 S 100 - 38

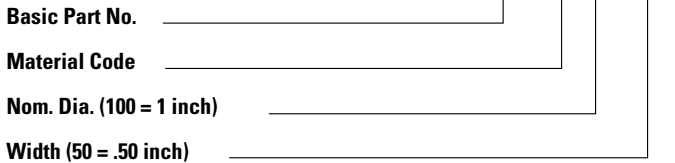

These band clamps are shipped flat with preformed ends

Basic Part Number

55083

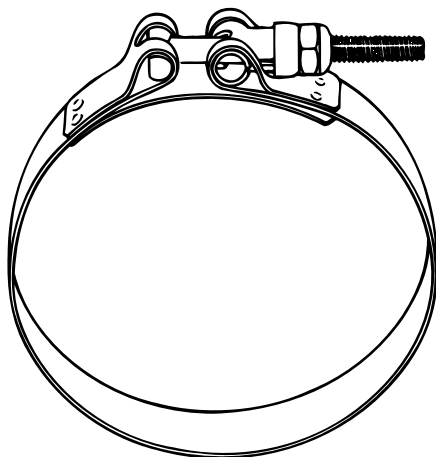

Basic Part Number	55083
Bolt Size & Material	¼-20, Plated Steel
Diameter Range	Tabulated
Band Material Thickness & Width	Stainless Steel .025x.75 .64x19.1
Locknut	Plated Steel, + 250°F (+121°C)

The Heavy Duty Band Clamp is designed to provide high performance clamping on heavy duty applications. Use of this clamp can eliminate the need for double clamping to secure heavy rubber hose connections on trucks, tractors, construction equipment, or wherever high reliability is needed with a minimum of maintenance. The corrosion resistant, stainless steel band provides even take-up. Two or more clamps can be easily coupled together for diameters in excess of **8.00 in.** (203.2 mm) sizes.

How to Order: Order by Part Number Shown

Dimensions: inches in boldface
mm in lightface

Part Number	Nominal Diameter	Maximum Diameter	Minimum Diameter	Part Number	Nominal Diameter	Maximum Diameter	Minimum Diameter
55083-150	1.50 38.1	1.53 38.9	1.38 35.1	55083-356	3.56 90.4	3.71 94.2	3.36 85.3
55083-163	1.63 41.4	1.66 42.2	1.47 37.3	55083-375	3.75 95.3	3.90 99.1	3.55 90.2
55083-175	1.75 44.4	1.78 45.2	1.59 40.4	55083-400	4.00 101.6	4.10 104.1	3.75 95.3
55083-188	1.88 47.8	1.91 48.5	1.72 43.7	55083-425	4.25 107.9	4.35 110.5	4.00 101.6
55083-200	2.00 50.8	2.03 51.6	1.84 46.7	55083-450	4.50 114.3	4.60 116.8	4.25 107.9
55083-212	2.12 53.8	2.18 55.4	1.92 48.8	55083-475	4.75 120.6	4.85 123.2	4.50 114.3
55083-225	2.25 57.2	2.34 59.4	2.05 52.1	55083-500	5.00 127.0	5.10 129.5	4.75 120.6
55083-238	2.38 60.5	2.47 62.7	2.18 55.4	55083-525	5.25 133.4	5.35 135.9	5.00 127.0
55083-256	2.56 65.0	2.65 67.3	2.36 59.9	55083-550	5.50 139.7	5.60 142.2	5.25 133.4
55083-282	2.82 71.6	2.91 73.9	2.62 66.5	55083-600	6.00 152.4	6.10 154.9	5.75 146.0
55083-294	2.94 74.7	3.03 77.0	2.74 69.6	55083-650	6.50 165.1	6.60 167.6	6.25 158.8
55083-306	3.06 77.7	3.21 81.5	2.86 72.6	55083-700	7.00 177.8	7.10 180.3	6.75 171.5
55083-325	3.25 82.6	3.40 86.4	3.05 77.5	55083-800	8.00 203.2	8.10 205.7	7.75 196.9
55083-344	3.44 87.4	3.59 91.2	3.24 82.3				

These band clamps are shipped flat with preformed ends.

How to Order: Order by Part Number Shown

Basic Part Number
NE100899

Part Number	Nominal Diameter	Maximum Diameter	Minimum Diameter
NE100899-0200	2.00 50.8	2.01 51.1	1.80 45.7
NE100899-0212	2.12 53.8	2.13 54.1	1.92 48.8
NE100899-0225	2.25 57.2	2.26 57.4	2.05 52.1
NE100899-0238	2.38 60.5	2.39 60.7	2.18 55.4
NE100899-0250	2.50 63.5	2.51 63.8	2.30 58.4
NE100899-0262	2.62 66.5	2.63 66.8	2.42 61.5
NE100899-0275	2.75 69.9	2.76 70.1	2.55 64.8
NE100899-0288	2.88 73.2	2.89 73.4	2.68 68.1
NE100899-0300	3.00 76.2	3.01 76.5	2.80 71.1
NE100899-0312	3.12 79.2	3.13 79.5	2.92 74.2
NE100899-0325	3.25 82.6	3.26 82.8	3.05 77.5
NE100899-0350	3.50 88.9	3.51 89.2	3.25 82.6
NE100899-0375	3.75 95.3	3.76 95.5	3.50 88.9
NE100899-0400	4.00 101.6	4.01 101.9	3.75 95.3
NE100899-0425	4.25 107.9	4.26 108.2	4.00 101.6
NE100899-0450	4.50 114.3	4.51 114.6	4.25 107.9
NE100899-0475	4.75 120.6	4.76 120.9	4.50 114.3
NE100899-0500	5.00 127.0	5.01 127.3	4.75 120.6
NE100899-0550	5.50 139.7	5.51 140.0	5.25 133.4
NE100899-0600	6.00 152.4	6.01 152.7	5.75 146.0
NE100899-0650	6.50 165.1	6.51 165.4	6.25 158.8
NE100899-0700	7.00 177.8	7.01 178.1	6.75 171.5
NE100899-0750	7.50 190.5	7.51 190.8	7.25 184.1
NE100899-0800	8.00 203.2	8.01 203.5	7.75 196.9

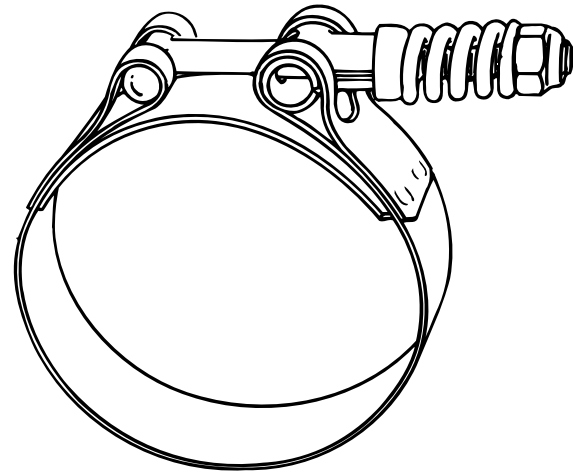

The Spring Loaded Band Clamp was developed to eliminate leakage problems inherent on connections requiring soft silicone hose. When assembled on the hose, the spring compensates for thermal expansion and contraction as well as cold flow of the hose.

Basic Part Number	NE100899
Bolt Size & Material	1/4-20 Plated Steel
Diameter Range	Tabulated
Band Material Thickness & Width	Stainless Steel .025 x .75 .64 x 19.1
Locknut	Plated Steel +250°F (+121°C)
Spring	Plated Music Wire

Dimensions: **inches in boldface**
mm in lightface

Basic Part Number
820

Basic Part Number
57120

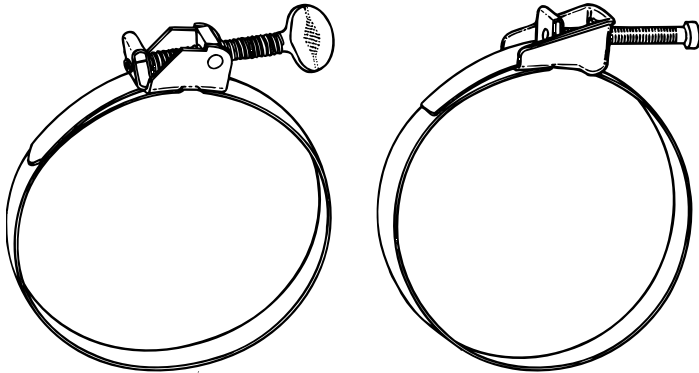

The adjustable feature of universal band clamps makes them ideal for clamping hose, duct or pipe. They can be used as a strap hanger or mounting bracket, or to clamp irregularly shaped objects.

Universal Band Clamps feature an adjustable diameter range enabling the reduction of individual part numbers within an inventory system.

Order by Part Number

Part Number	Maximum Diameter
57120-10	10.75 2.73
57120-18	18.00 457.20

Dimensions: inches in boldface
mm in lightface

Basic Part Number	820	57120
	1/4-20	3/8-16
	Plated Alloy Steel	
	Stainless Steel	
Thickness & Width	.012x.56 .31x14.3	.020x1.25 .51x31.8
Saddle Material	Stainless Steel	Plated Carbon Steel
Minimum Nominal Diameter	.69 17.5	1.50 38.1

How to Order: Order by Part Number shown

Part Number	Max. Dia.	Part Number	Max. Dia.	Part Number	Max. Dia.	Part Number	Max. Dia.	Part Number	Max. Dia.	Part Number	Max. Dia.	Part Number	Max. Dia.
820-13	2.12 53.85	820-16	3.62 91.95	820-20	6.12 155.45	820-26	9.12 231.65	820-32	12.12 307.85	820-38	18.12 460.25	820-44	24.12 612.65
820-14	2.62 66.55	820-17	4.12 104.65	820-22	7.12 180.85	820-28	10.12 257.05	820-34	14.12 358.65	820-40	20.12 511.05	820-48	28.12 714.25
820-15	3.12 79.25	820-18	5.12 130.05	820-24	8.12 206.25	820-30	11.12 282.45	820-36	16.12 409.45	820-42	22.12 561.85	820-64	44.12 1120.65

Universal Band Clamp/Installation Instructions

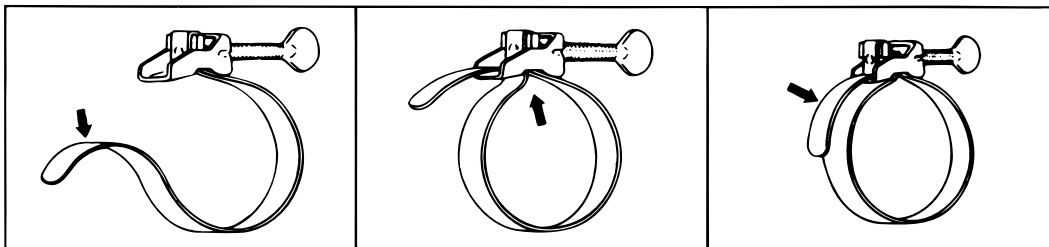

1. Bend strap outward to simplify insertion through saddle.
2. Unscrew thumbscrew fully, then wrap strap around object or objects to be clamped, inserting strap end through opening in saddle.
3. Pull up snug and fold strap into saddle, bending tip inward so that extra material will conform to shape of object being clamped. Tighten screw.

TO REMOVE:
Loosen screw and press screw head down toward strap. Lift on free end of clamp

**Basic Part Number
NH2000110**

The Adjustable Band Clamp is designed for flexibility and allows for quick and easy assembly of irregular shapes as well as round objects. For diameters in excess of **7.66 in.** (194.6 mm), two or more clamps can be coupled together.

These band clamps feature an adjustable diameter range enabling the reduction of individual part numbers within an inventory system.

Band clamps will be shipped flat.



Dimensions: inches in boldface
mm in lightface

How to Order: Order by Part Number Shown

Basic Part Number	NH2000110-10	NH2000110-20	NH2000110-30
Bolt Size & Material	1/4-20, Plated Steel		
Diameter Range	2.50-4.00 63.5-101.6	4.00-6.00 101.6-152.4	6.00-7.66 152.4-194.6
Band Material	Stainless Steel		
Thickness & Width	.020x.75 .51x19.1		
Locknut	Plated Steel, +250°F (+121°C)		

Adjustable Band Clamp/ Installation Instructions

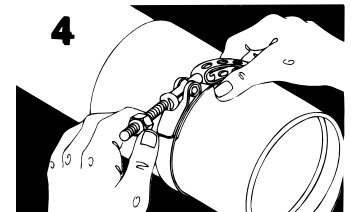
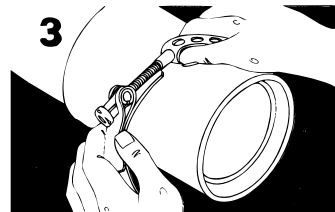
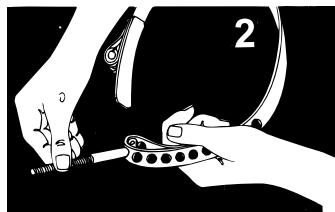

1. Remove the T-Bolt from the trunnion and insert in the desired hole on the inside of the clamp. Which hole to use depends on the diameter of the application.
2. Bend the excess length of clamp over the end of the T-Bolt.
3. Insert the T-Bolt through the trunnion.
4. Tighten the clamp down with the nut.

Band Clamp/Adjustable Over Center Latch

Basic Part Number

MB9360

MB9460

MB9560

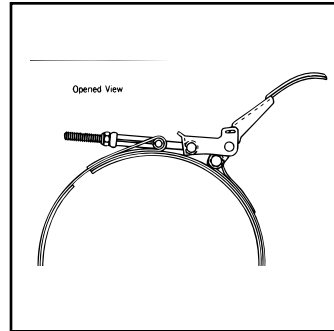
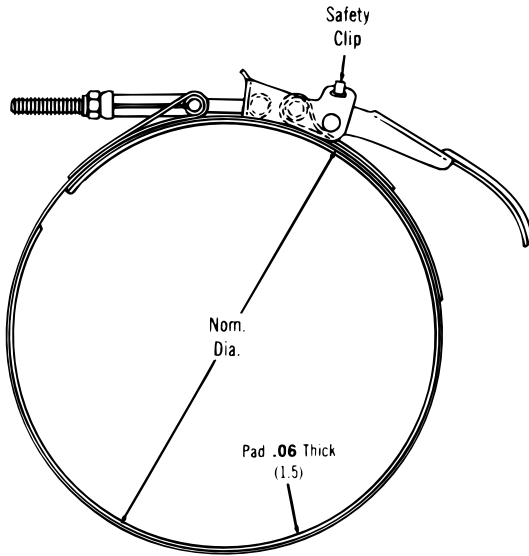

Min Nom. Dia.:

MB9360 = **2.81 in.** (71.4 mm)
 MB9460 = **6.50 in.** (165.1 mm)
 MB9560 = **6.50 in.** (165.1 mm)

Max. Dia.:

MB9360 = **20.00 in.** (508.0 mm)
 MB9460 = **31.00 in.** (787.4 mm)
 MB9560 in. = **31.00 in.** (787.4 mm)

Basic Part Number	MB9360	MB9460	MB9560
Bolt Size	10-24	¼-20	5/16-18
Minimum Nominal Diameter	2.81 71.4	6.50 165.1	
Band Material and Thickness J = 316 Stainless Steel, 316 Stainless Steel T-Bolt	.032 .81	.032 .81	.050 1.27
S=301 Stainless Steel 316 Stainless Steel T-Bolt	.020 .51	.032 .81	.050 1.27
Band Widths	.62, .75, .88, 1.00 15.7, 19.1, 22.4, 25.4	.88, 1.00, 1.25, 1.50 22.4, 25.4, 31.8, 38.1	

Dimensions: inches in boldface
mm in lightface

Example of Part Number for Ordering

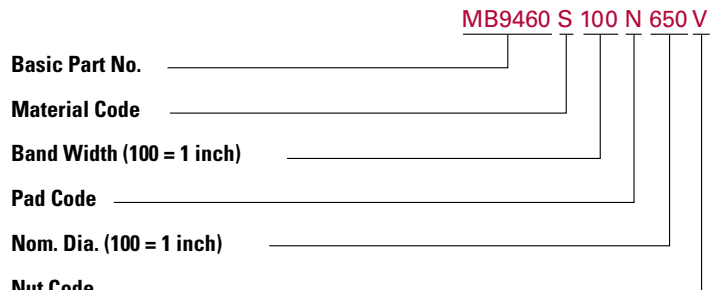

Pad Code:

P = Pad, Cork, Neoprene; **.06 in.** (1.52 mm)
 N = No pad

Nut Code:

C = Plated Steel Hex Nut
 F = Plated Steel Fiber Insert Hex Locknut
 T = Stainless Steel Hex Nut
 V = Stainless Steel All Metal Hex Locknut

Note: Nominal diameter is taken to the strap I.D. Allow for pad thickness when ordering

Basic Part Number
MB9914
MB9915

Particularly suited for mounting oxygen bottles or other containers. They can be used to support piping and other objects. The clamps are also used for securing cylindrical objects during shipping.

Min. Nom. Dia.:
 MB9914=**1.50 in.** (38.1 mm)
 MB9915=**1.50 in.** (38.1 mm)

Max. Dia.:
 MB9914=**12.00 in.** (304.8 mm)
 MB9915=**13.99 in.** (355.3 mm)

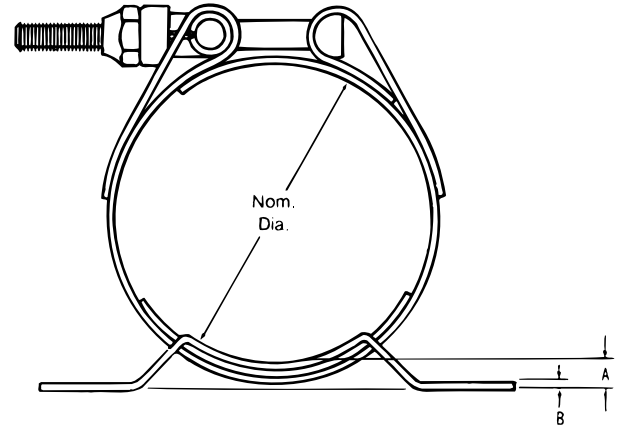

Dimensions: inches in boldface
 mm in lightface

Basic Part Number	MB9914	MB9915
Bolt Size	10-24	¼-20
Nominal Diameter	Min. 1.50 38.1	Max. 12.00 304.8
Band Material & Thickness	.025 J=316 Stainless Steel, 316 Stainless Steel T-Bolt	.040* 1.02
S=301 Stainless Steel 316 Stainless Steel T-Bolt	.020 .51	.025 .64

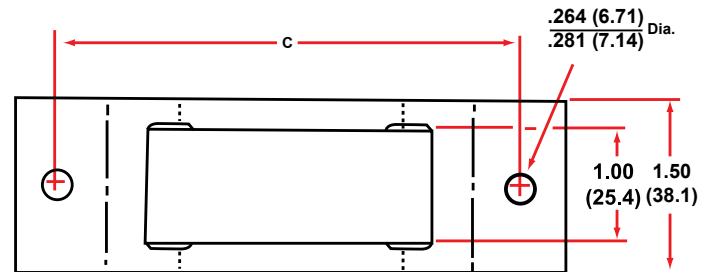

* Band Thickness: **.032 in.** (.81 mm) for nominal diameters under **3.00 in.** (76.2 mm)

Nominal Diameter	Bracket Offset A	Bracket Thickness B	Bracket Hole Center C
1.50-2.49 38.1-63.3	.16 4.1	.040 1.02	2.50 63.5
2.50-4.49 63.5-114.1	.30 7.6	.050 1.27	2.75 69.9
4.50-12.00 114.3-304.8	.41 10.4	.063 1.60	4.00 101.6

Example of Part Number for Ordering

MB9914-900 S V

Basic Part No. _____

Nom. Dia. (100 = 1 inch) _____

Material Code _____

Nut Code _____

Nut Code:
 C = Plated Steel Hex Nut
 F = Plated Steel Fiber Insert Hex Locknut
 T = Stainless Steel Hex Nut
 V = Stainless Steel All Metal Hex Locknut

Band Straps

For general tie-down or holding applications. Ideal for strapping down hydraulic accumulators, fuel tanks, etc.

Dimensions: inches in boldface
mm in lightface

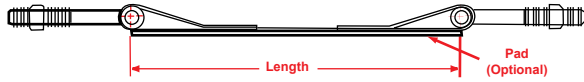

Basic Part No.	MB5306	MB5406	MB5506	MB5606
Min. Length	2.50 63.5	2.75 69.9	6.50 165.1	9.00 228.6

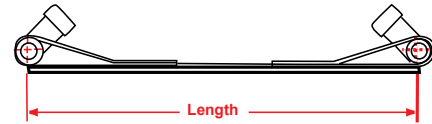

Basic Part No.	MB5308	MB5408	MB5508	MB5608
Min. Length	2.50 63.5	2.75 69.9	6.50 165.1	9.00 228.6

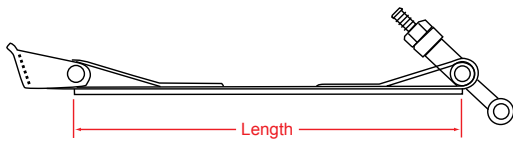

Basic Part No.	MB5310	MB5410	MB5510	MB5610
Min. Length	2.50 63.5	2.75 69.9	6.50 165.1	9.00 228.6

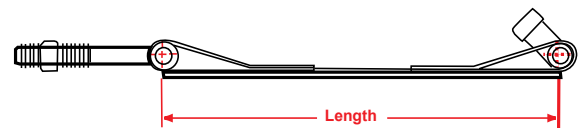

Basic Part No.	MB5312	MB5412	MB5512	MB5612
Min. Length	2.50 63.5	2.75 69.9	6.50 165.1	9.00 228.6

Example of Part Number for Ordering

MB5306 S 52 N 350 V

Basic Part No. _____

Material Code _____

Strap Width (100 = 1 inch) _____

Pad Code _____

Strap Length (100 = 1 inch) _____

Nut Code _____

Pad Code:
P = Pad, Cork, Neoprene; **.06 in.** (1.52 mm)
N = No pad

Nut Code:
C = Plated Steel Hex Nut
F = Plated Steel Fiber Insert Hex Locknut
T = Stainless Steel Hex Nut
V = Stainless Steel All Metal Hex Locknut
Applies only to straps that contain T-Bolts.

Basic Series No.	MB5300	MB5400	MB5500	MB5600
Bolt Size	10-24 x	¼-20 x	5/16-18 x	3/8-16 x
Length	2.25	3.00	4.50	5.00
Band Material & Thickness				
J=316 Stainless Steel, 316 Stainless Steel T-Bolt	.025 .64	.040 1.02	.063 1.60	.080 2.03
S=301 Stainless Steel, 316 Stainless Steel T-Bolt	.020 .51	.025 .64	.050 1.27	.063 1.60
Band Widths	.52, .62, .75, .88 13.2, 15.7, 19.1, 22.4	.75, .88, 1.00, 1.25 19.1, 22.4, 25.4, 31.8	.88, 1.00, 1.25, 1.50 22.4, 25.4, 31.8, 38.1	1.25, 1.50, 1.75, 2.00 31.8, 38.1, 44.5, 50.8

Strap Assemblies

Note: When assembly part no. is ordered, the length will be the total length of both straps, plus the gap reference.

Dimensions: inches in boldface
mm in lightface

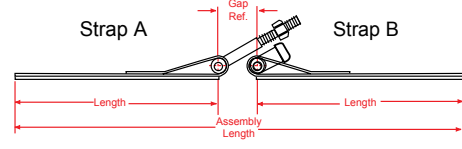
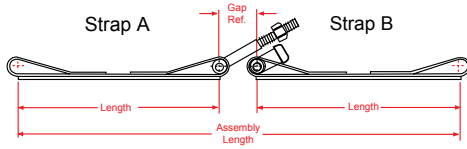

Assembly Part No. (Both A&B)	Strap A Basic Part No.	Strap B Basic Part No.	Min. Strap Length (Each Side)	Gap Ref.
MB5316	MB5313	MB5315	2.50 63.5	.81 20.8
MB5416	MB5413	MB5415	2.75 69.9	1.00 25.4
MB5516	MB5513	MB5515	6.50 165.1	1.25 31.8
MB5616	MB5613	MB5615	9.00 228.6	1.25 31.8

Assembly Part No. (Both A&B)	Strap A Basic Part No.	Strap B Basic Part No.	Min. Strap Length (Each Side)	Gap Ref.
MB5314	MB5309	MB5311	2.25 57.2	.81 20.8
MB5414	MB5409	MB5411	2.25 57.2	1.00 25.4
MB5514	MB5509	MB5511	4.00 101.6	1.25 31.8
MB5614	MB5609	MB5611	5.25 133.4	1.25 31.8

Loop Dia. : Part No. MB5316: **.32 in.** (8.1 mm); Part No. MB5416: **.38 in.** (9.7 mm);
Part No. MB5516: **.50 in.** (12.7 mm); Part No. MB5616: **.50 in.** (12.7 mm).

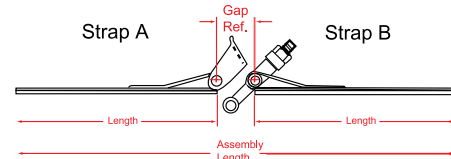
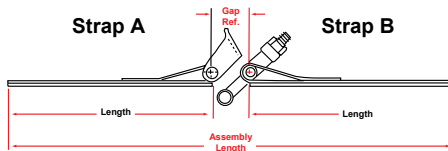

Assembly Part No. (Both A&B)	Strap A Basic Part No.	Strap B Basic Part No.	Min. Strap Length (Each Side)	Gap Ref.
MB5320	MB5321	MB5323	2.50 63.5	1.31 33.3
MB5420	MB5421	MB5423	2.75 69.9	1.56 39.6
MB5520	MB5521	MB5523	6.50 165.1	1.88 47.8
MB5620	MB5621	MB5623	9.00 228.6	3.00 76.2

Assembly Part No. (Both A&B)	Strap A Basic Part No.	Strap B Basic Part No.	Min. Strap Length (Each Side)	Gap Ref.
MB5318	MB5317	MB5319	2.25 57.2	1.31 33.3
MB5418	MB5417	MB5419	2.25 57.2	1.56 39.6
MB5518	MB5517	MB5519	4.00 101.6	1.88 47.8
MB5618	MB5617	MB5619	5.25 133.4	3.00 76.2

Loop Dia. : Part No. MB5320: **.32 in.** (8.1 mm); Part No. MB5420: **.38 in.** (9.7 mm);
Part No. MB5520: **.50 in.** (12.7 mm); Part No. MB5620: **.50 in.** (12.7 mm).

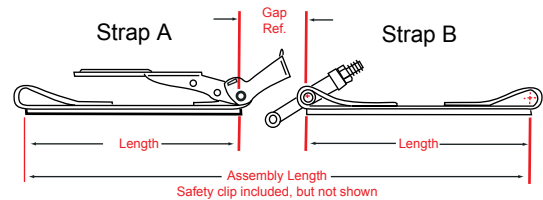
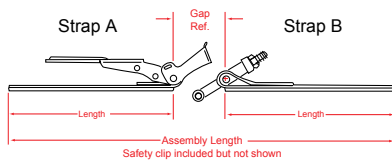

Assembly Part No. (Both A&B)	Strap A Basic Part No.	Strap B Basic Part No.	Min. Strap Length (Each Side)	Gap Ref.
MB5328	MB5327	MB5329	5.00 127.0	1.50 36.8
MB5428	MB5427	MB5429	6.25 158.8	2.00 49.0
MB5528	MB5527	MB5529	6.50 165.1	2.00 49.0
MB5628	MB5627	MB5629	9.00 228.6	2.50 61.2

Assembly Part No. (Both A&B)	Strap A Basic Part No.	Strap B Basic Part No.	Min. Strap Length (Each Side)	Gap Ref.
MB5324	MB5325	MB5326	2.25 57.2	1.50 36.8
MB5424	MB5425	MB5426	2.50 63.5	2.00 49.0
MB5524	MB5525	MB5526	4.00 101.6	2.00 49.0
MB5624	MB5625	MB5626	5.25 133.4	2.50 61.2

Loop Dia. : Part No. MB5328: **.32 in.** (8.1 mm); Part No. MB5428: **.38 in.** (9.7 mm);
Part No. MB5528: **.50 in.** (12.7 mm); Part No. MB5628: **.50 in.** (12.7 mm).

See page 40 for example of Part Number for Ordering.

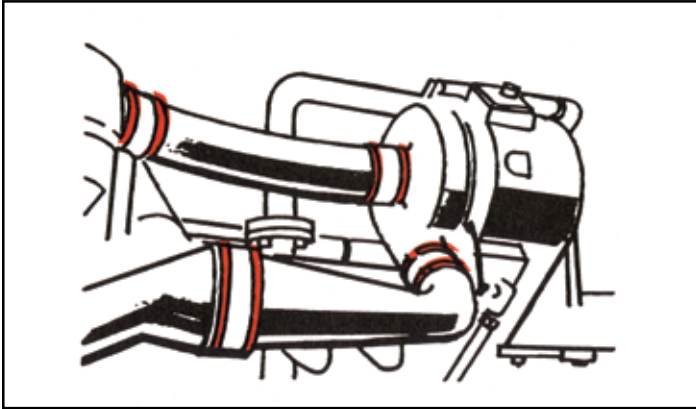

Band Clamps secure hose segments on the turbo-charger/inter-cooler duct work.

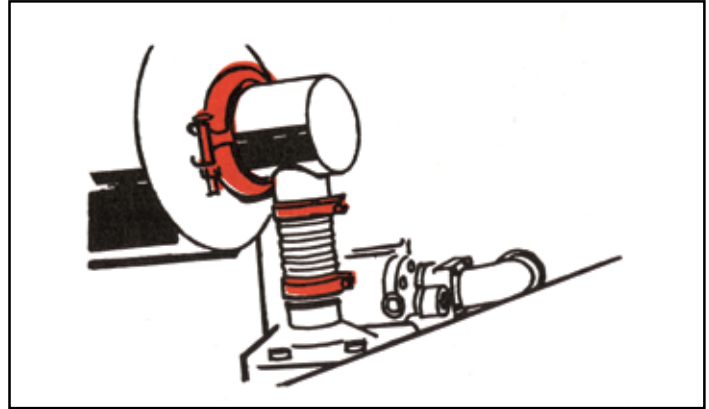

Band Clamps and hose segment make easy work of this compressor air supply.

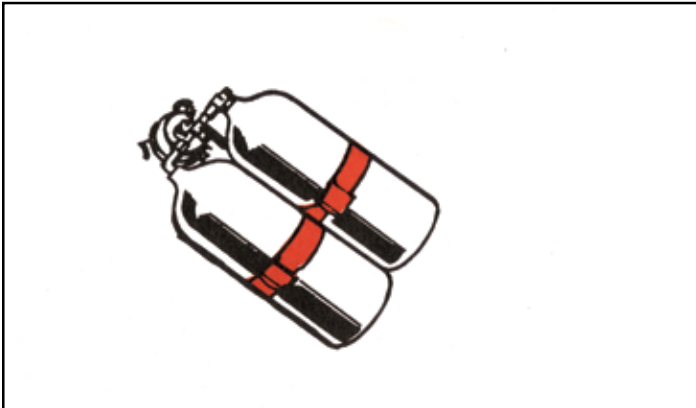

Special low-profile Band Clamp assembly keeps Scuba bottle safe, easy to change.

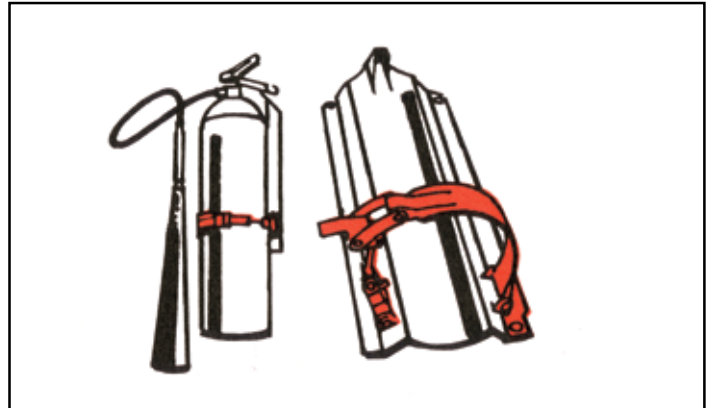

Aeroquip fire extinguisher mount makes ideal use of clamp with quick release.

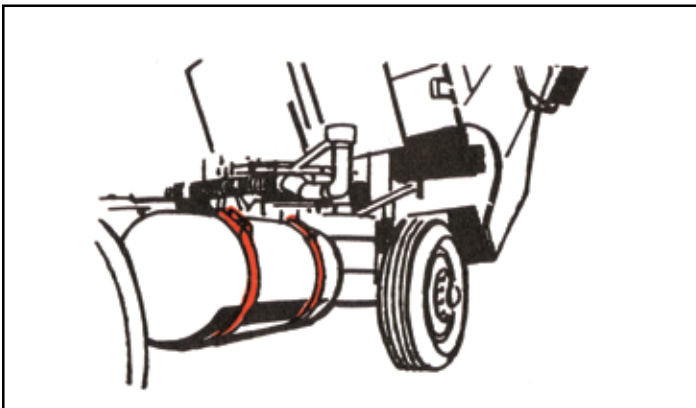

Eaton Fuel Tank Straps provide high strength and install in seconds.

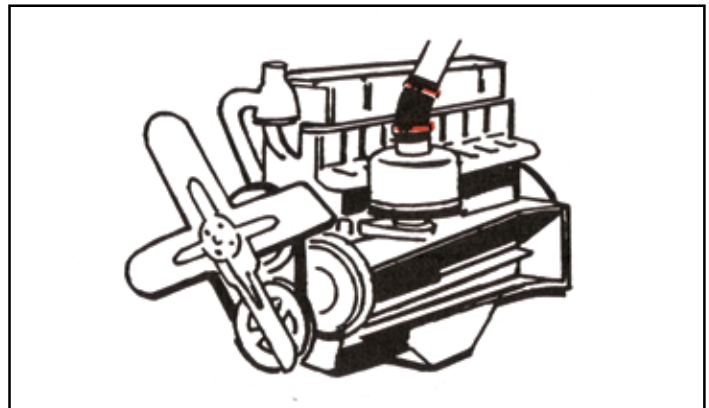

Heavy duty truck air intake hoses are secured by Heavy Duty Band Clamps.

Section Index	Page
Band Strength Chart	46
Bolt Strength Chart	45
Flange and V-Band Coupling Materials and Temperature Correction Charts	45
V-Band Coupling Selection	44

V-Band Coupling Selection under combined loading of pressure, bending and axial loads.

The following factors must be determined: loading, desired safety factor and size.

Loading may consist of internal pressure, bending moment and/or axial tension.

The following steps should be followed to select the correct V-Band Coupling from this catalog:

Step 1. If an internal pressure load exists, use Formula 1.

$$N_p = \frac{PD}{4}$$

Step 2. If a bending moment load exists, use Formula 2.

$$N_b = \frac{4M}{\pi D^2}$$

Step 3. If an axial tension load exists (other than pressure), use Formula 3.

$$N_a = \frac{A}{\pi D}$$

Step 4. If combined loading exists, determine the total load intensity. Formula 4 is used.

$$N = N_p + N_b + N_a$$

Example:

A V-Band Coupling is required for the following conditions:

Tube O.D. = **3.00 inch**

Operating Pressure = **300 psi**

Bending Moment = **2000 pound-inch**

Axial Load = **1000 lbs**

Example:

$$N_p = \frac{300(3.00)}{4} = \mathbf{225 \text{ lb/inch}}$$

$$N_b = \frac{4(2000)}{\pi(3.00)^2} = \mathbf{283 \text{ lb/inch}}$$

$$N_a = \frac{1000}{\pi(3.00)} = \mathbf{106 \text{ lb/inch}}$$

$$N = 225 + 283 + 106 = \mathbf{614 \text{ lb/inch}}$$

To convert total load intensity to an equivalent operating pressure, use Formula 5.

$$EOP = \frac{4(614)}{3} = \mathbf{819 \text{ psi}}$$

For a safety factor of 3, the required system burst pressure would be 2457 psi. The burst pressure rating for individual V-Band Couplings are charted on pages 12 through 24.

Explanation of symbols

Formula	Symbol	Meaning	Units	Formula
1	N_p	Load Intensity Due to Pressure	pounds/ inch of circumference	$N_p = \frac{PD}{4}$
2	N_b	Load Intensity Due to Bending Movement	pounds/ inch of circumference	$N_b = \frac{4M}{\pi D^2}$
3	N_a	Load Intensity Due to Axial Tension	pounds/ inch of circumference	$N_a = \frac{A}{\pi D}$
4	N	Total Load Intensity	pounds/ inch of circumference	$N = N_p + N_b + N_a$
5	EOP	Equivalent Operating Pressure	psi	$EOP = \frac{4N}{D}$
	D	Shell or Flange O.D.	inch	
	P	Pressure	psi	
	M	Bending Moment	pound inch	
	A	Axial Tension	pounds	

The above formulas are applicable for systems with static load conditions.

Note: Safety factor and material selection should be based on strength requirements and environmental conditions.

Table 1. Flange material and temperature correction chart

Material	+70°F +21.1°C	+200°F +93.3°C	+400°F +204.4°C	+600°F +315.6°C	+800°F +426.7°C
300 Series Stainless Steel	1.00	.88	.75	.68	.60
Carbon Steel	.67	.63	.59	.51	—
Aluminum	.50	.45	.26	—	—

Table 2. V-Band Coupling material and temperature correction chart.

Material	+70°F +21.1°C	+200°F +93.3°C	+400°F +204.4°C	+600°F +315.6°C	+800°F +426.7°C
301 Stainless Steel	1.00	.88	.75	.68	.60
316 Stainless Steel	.50	.47	.44	.42	.39
Carbon Steel	.50	.46	.43	.37	—

Table 3. Bolt Strength

Maximum torque levels are not always required for proper joint function. Apply nut torque to a level where joint is properly closed. Bolt strength values given below are based on material properties equivalent to SAE J429, Grade 5, at + 70°F (21.1°C).

Bolt Size	Bolt Material	Maximum Allowable Torque (in-lbs. N-m)	Minimum Breaking Strength (lbs./kg)
10-24	Stainless or Alloy Steel	50 6	2100 955
¼-20	Stainless or Alloy Steel	75 8	3800 1727
	Carbon Steel*	50 6	2100 955
5/16-18	Stainless or Alloy Steel	200 23	6300 2864
3/8-16	Stainless or Alloy Steel	450 51	9300 4227

Note: **in-lbs and lbs in boldface**/ N-m and kg in lightface

* Equivalent to SAE J429, Grade 2.

Table 4. Band Strengths

The strength values below are based on 301 stainless steel at **+70°F** (+21.1°C). To adjust for other materials and/or temperatures, multiply the band strength value by the applicable factor from Table 2.

		Band Thickness								
		0.020 0.51	0.025 0.64	0.032 0.81	0.040 1.02	0.050 1.27	0.063 1.60	0.080 2.03	0.090 2.29	0.125 3.18
Bandwidth	0.25 6.35	375 170	469 213	600 273	750 341	938 426	1181 537	1500 682	1688 767	2344 1065
	0.38 9.53	563 256	703 320	900 409	1125 511	1406 639	1772 805	2250 1023	2531 1151	3516 1598
	0.50 12.70	750 341	938 426	1200 545	1500 682	1875 852	2363 1074	3000 1364	3375 1534	4688 2131
	0.62 15.88	930 423	1163 528	1488 676	1860 845	2325 1057	2930 1332	3720 1691	4185 1902	5813 2642
	0.75 19.05	1125 511	1406 639	1800 818	2250 1023	2813 1278	3544 1611	4500 2045	5063 2301	7031 3196
	0.88 22.22	1313 597	1641 746	2100 955	2625 1193	3281 1491	4134 1879	5250 2386	5906 2685	8203 3729
	1.00 25.40	1500 682	1875 852	2400 1091	3000 1364	3750 1705	4725 2148	6000 2727	6750 3068	9375 4261
	1.12 28.58	1680 764	2100 955	2688 1222	3360 1527	4200 1909	5292 2405	6720 3055	7560 3436	10500 4773
	1.25 31.75	1875 852	2344 1065	3000 1364	3750 1705	4688 2131	5906 2685	7500 3409	8438 3835	11719 5327
	1.50 38.10	2250 1023	2813 1278	3600 1636	4500 2045	5625 2557	7088 3222	9000 4091	10125 4602	14063 6392
	1.75 44.45	2625 1193	3281 1491	4200 1909	5250 2386	6563 2983	8269 3759	10500 4773	11813 5369	16406 7457
	2.00 50.80	3000 1364	3750 1705	4800 2182	6000 2727	7500 3409	9450 4295	12000 5455	13500 6136	18750 8523

Dimensions: **inches in boldface**
mm in lightface

Minimum Yield Strength: **pounds in boldface**
kg in lightface

Eaton
Aerospace Group
Fluid & Electrical Distribution Division
90 Clary Connector
Eastanollee, Georgia 30538
Phone: (706) 779 3351
Fax: (706) 779 2638

Eaton
Aerospace Group
9650 Jeronimo Road
Irvine, California 92618
tel: (949) 452-9500
fax: (949) 452-9555
www.eaton.com/aerospace

Copyright © 2016 Eaton
All Rights Reserved
Teflon is a registered trademark of Dupont.
Form No. TF100-141
July 2016