

EAFR-110PLV current and arc light sensor relay user manual

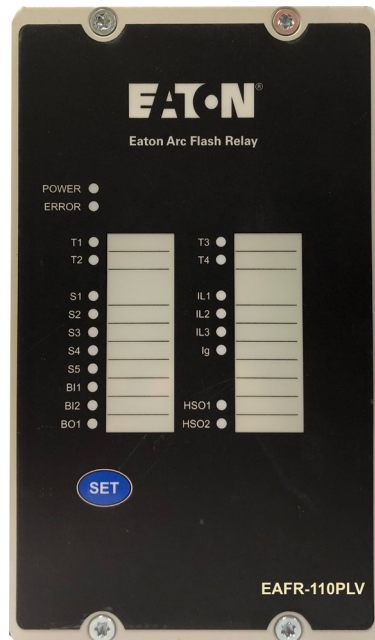

Contents

Description	Page
1. Introduction	2
2. General	2
3. Operation and configuration	5
4. Arc sensors	9
5. System self-supervision	11
6. Connections	12
7. Wiring diagrams	13
8. Dimensions and installation	14
9. Testing	16
10. Troubleshooting guide	19
11. Technical data	19
12. Ordering codes	21



Powering Business Worldwide

1. Introduction

Read these instructions carefully and inspect the equipment to become familiar with it before trying to install, operate, service, or maintain it.

Electrical equipment should be installed, operated, serviced, and maintained only by qualified personnel. Local safety regulations should be followed. No responsibility is assumed by Eaton for any consequences arising out of the use of this material.

We reserve right to changes without further notice.

1.1 Abbreviations

CB	–	Circuit breaker
CBFP	–	Circuit breaker failure protection
EMC	–	Electromagnetic compatibility
EPROM	–	Erasable programmable read only memory
HW	–	Hardware
LED	–	Light emitting diode
LV	–	Low voltage
ms	–	Millisecond
MT	-	Master trip
MV	–	Medium voltage
NC	–	Normally closed
NO	–	Normally open
SF	–	System failure
SW	–	Software
uP	–	Microprocessor

2. General

The Eaton Arc Flash Relay (EAFR)-110PLV is a sophisticated micro-processor based arc flash protection relay with combined current and arc sensing. Combined current and arc sensing provides an integrated dual trip criteria. It is designed to minimize the damage caused by an arcing fault (arc flash) by tripping the circuit breaker sourcing the fault current, and optionally, an Arc Quenching Device. The EAFR-110PLV complete system self-supervision function provides the highest level of dependability by continuously monitoring all internal system functions along with external connections.

The EAFR-110PLV is designed according to the latest protection relay standards and is therefore suitable for installations in any environment, such as utility, traditional or renewable power plants, off shore, marine, oil and gas, mining, steel, or any other heavy industry applications, as well as commercial and institutional electrical systems. The EAFR-110PLV is suitable for either medium voltage or low voltage switchgear and motor control center applications in both new and retrofit installations.

2.1 Arc protection relay EAFR-110PLV features

The EAFR-110PLV is a multi-purpose arc flash protection relay and can be applied to a variety of applications. The EAFR-110PLV can be used as a stand-alone relay or as a main relay of a more complex arc protection system through the binary bus. The EAFR-110PLV may also be used in conjunction with the Arc Quenching Device (AQD) for the maximum level of arc fault protection.

The main features of EAFR-110PLV:

- (110-220) Vac / (125-250) Vdc auxiliary power supply;
- Three phase current inputs IL1, IL2, and IL3 (1A / 5A nominal);
- One ground (earth fault) current input Ig (1A / 5A nominal);
- Four arc point sensor channels
- Two binary inputs (BI1, BI2) 24 Vdc;
- Two high-speed semiconductor trip outputs (direct trip circuit rated);
- Two normally open (NO) trip relay outputs with direct trip circuit rated contacts (T1, T2);
- One binary output (24 Vdc);
- One system failure relay, form C output (SF).

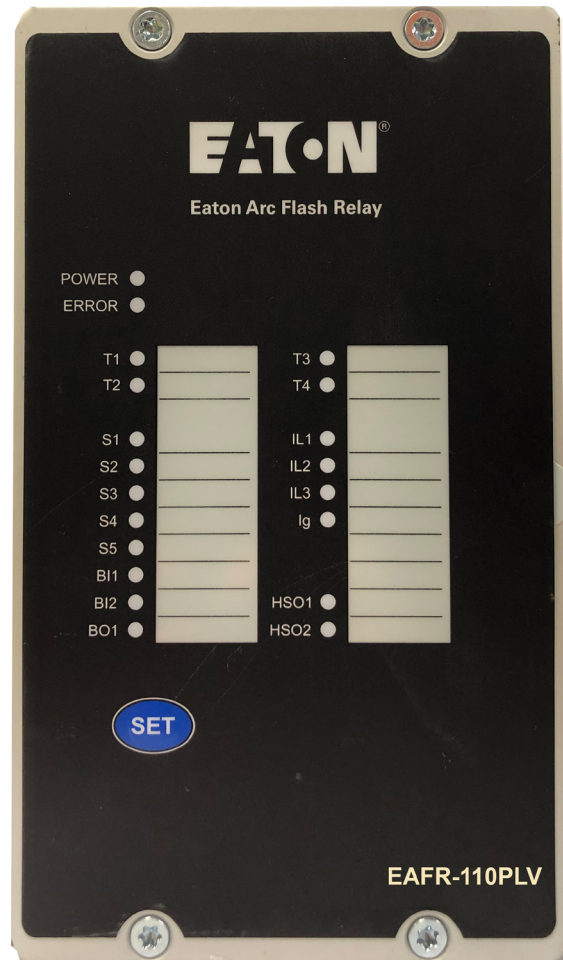

Figure 1. Arc protection relay EAFR-110PLV.

2.2 Simplified block diagram

The simplified block diagrams in Figure 2 shows the main components of the EAFR-110PLV relay.

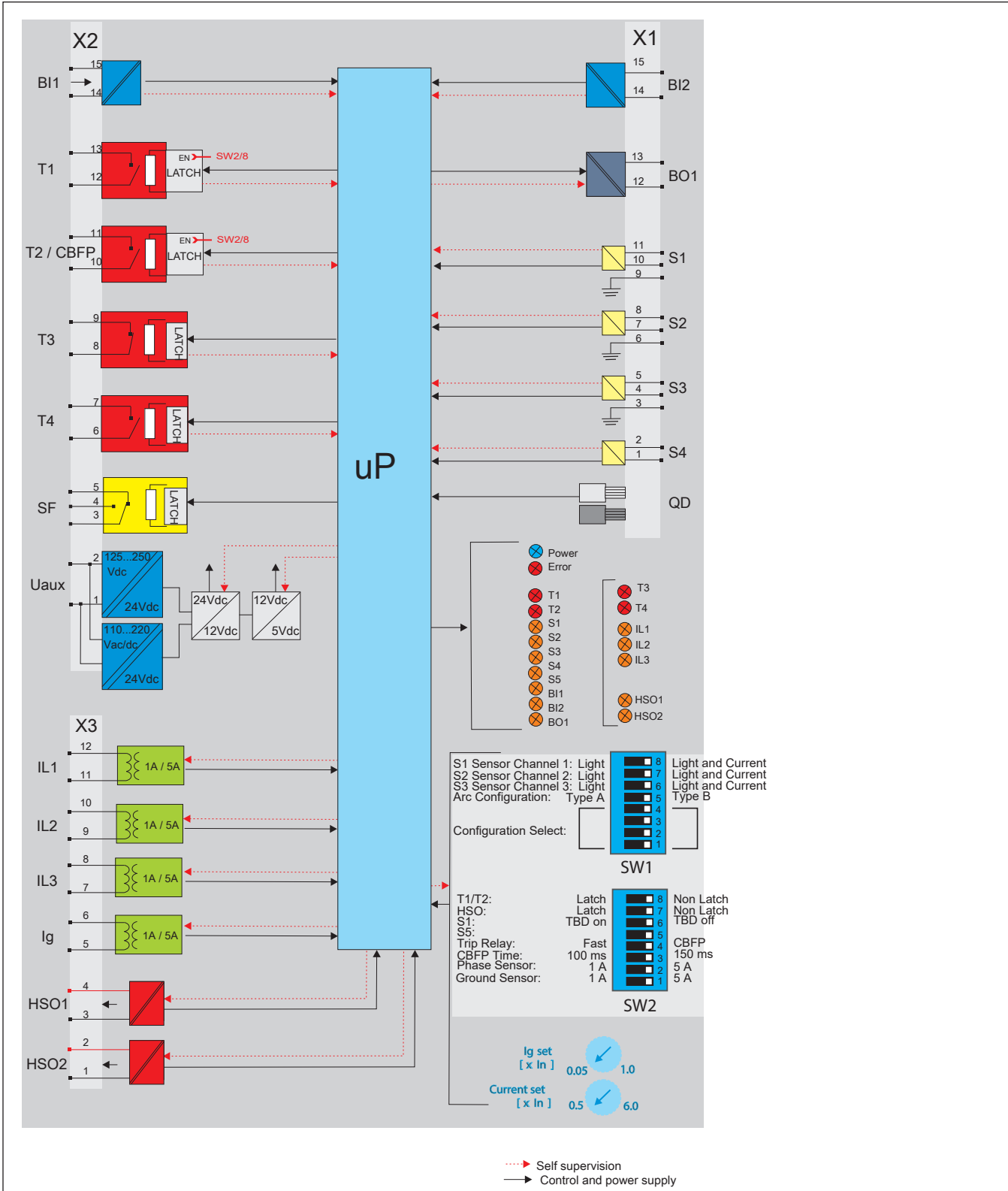

Figure 2. EAFR-110PLV simplified block diagram.

3. Operation and configuration

3.1 LED indicator functions

The EAFR-110PLV contains 20 indication LEDs. A user definable text list can be slid in under the label pocket for identifying each LED function (except POWER and ERROR LEDs). LEDs are located at the front plate of the relay for clear viewing without a need for opening doors.

During power up, the relay performs a LED-test. All LEDs are turned on for two seconds and then off. Only the blue POWER LED will remain on. After powered up, the relay will go into the protection mode in 50 ms even while the LED test is being performed. During normal operation, only the blue power LED is on.

All current measuring channels (IL1, IL2, AND IL3, and Ig) have indication LEDs. When any channel exceeds the set threshold value, the indication LED is turned on until a manual reset is performed. In an open CT condition, the corresponding current channel indicator and the ERROR LED will be blinking.

The sensor LEDs are off during the inactive condition. If the arc sensor is activated, the corresponding sensor channel LED will turn on if the activation is longer than 1.5 ms. The sensor LED activation function is latched (steady light). To clear the LED the "SET" button should be pressed.

In the case of loose sensor wire or configuration mismatch (new sensor attached without running auto-configuration system setup, see Section 3.3.1) situation, the corresponding LED for that sensor will start flashing and the ERROR LED will activate.

The Binary I/O LEDs are indicating the I/O-line status. If any of the lines become active for more than 1.5 ms, the corresponding LED will illuminate (latch).

In a trip situation, the corresponding trip LED will illuminate. Trip outputs are controlled by dipswitch settings (see Section 3.6).

All activation and trip indication LEDs are latched, even if the dipswitch setting is in the non-latched mode. They have to be cleared by pushing the "SET" button.

LED indications are stored in non-volatile EPROM memory for identifying the trip information in case the auxiliary power is lost. When re-powering the relay after power supply loss, the actual LED status can be visualized from the front of the relay.

3.2 LED operation quick guide

Table 1 describes the function of each indicator LED on the front of the EAFR-110PLV relay.

Table 1. LED operation quick guide.

LED	Off	Steady on	Blinking	Action if abnormal
POWER Blue	Auxiliary supply disconnected.	Auxiliary power connected.	N/A	Check the power source.
ERROR Red	System healthy.	System failure.	Configuration mismatch. Protection partly operational.	Verify system condition. See Sections 11: Troubleshooting guide and 5: System self-supervision.
T1 Red	Normal status.	Trip relay T1 activated.	N/A	Check the reason for trip. Clear the fault and reset indications by pushing SET button
T2 Red	Normal status.	Trip relay T2 activated.	N/A	Check the reason for trip. Clear the fault and reset indications by pushing SET button
S1 Amber	Normal status.	Sensor channel 1 activated by light information.	Sensor channel 1 discontinuity or system setup not performed.	Check why the sensor activated, check the sensor continuity, or perform a system setup (see Section 3.3.1: Auto configuration (System setup)).
S2 Amber	Normal status.	Sensor channel 2 activated by light information.	Sensor channel discontinuity or system setup not performed.	Check why the sensor activated, check the sensor continuity, or perform a system setup (see Section 3.3.1: Auto configuration (System setup)).
S3 Amber	Normal status.	Sensor channel 3 activated by light information.	Sensor channel 3 discontinuity or system setup not performed.	Check why the sensor activated, check the sensor continuity, or perform system setup (see Section 3.3.1: Auto configuration (System setup)).
S4 Amber	Normal status.	Sensor channel 4 activated by light information.	Sensor channel 4 discontinuity or system setup not performed.	Check why the sensor activated, check the sensor continuity, or perform system setup (see Section 3.3.1: Auto configuration (System setup)).
BI1 Amber	Normal status.	Binary input 1 activated.	Binary input 1 loose connection.	Check the binary input wiring.
BI2 Amber	Normal status.	Binary input 2 activated.	Binary input 2 loose connection.	Check the binary input wiring.
BO1 Amber	Normal status.	Binary output activated.	N/A	
IL1 Amber	Normal status, actual current below set point.	IL1 current above the set point.	Open CT connection in channel IL1.	Check the current set point levels or check the CT wiring.
IL2 Amber	Normal status, actual current below set point.	IL2 current above set point.	Open CT connection in channel IL2.	Check the current set point levels or check the CT wiring.
IL3 Amber	Normal status, actual current below set point.	IL3 current above set point.	Open CT connection in channel IL3.	Check the current set point levels or check the CT wiring.
Ig Amber	Normal status, actual current below set point.	Ground (earth fault) current above set point.	N/A	Check the earth current set point level.
HSO1 Red	Normal status.	HSO 1 activated.	N/A	Check the reason for activation. Clear the fault and reset indications by pushing SET button.
HSO2 Red	Normal status.	HSO 2 activated.	N/A	Check the reason for activation. Clear the fault and reset indications by pushing SET button.

3.3 Push-button description

The EAFR-110PLV contains one single push-button (SET) that can be used for all operational functions of the relay. The SET push-button is used to initialize the auto-configuration of the system (see Section 3.3.1) and for resetting the indicators and latched output relays.

3.3.1 Auto configuration (system setup)

When all current circuits, sensors, and binary lines have been connected, an auto-configuration procedure must be executed. The initialization sequence is performed by pressing the SET button for two seconds, and the EAFR-110PLV sensor LEDs and B11/B12 LEDs start blinking. The relay scans these inputs to see if they are connected and, when an input is detected, the corresponding LEDs are illuminated to mark that a connection was found. The inputs without a connection continue blinking during the remaining three seconds. After five seconds, all LEDs are turned off. During this system setup, the dipswitch settings are also stored in non-volatile memory.

All sensor inputs will remain operational even when not auto configured. The auto configuration is only used for self-supervision purposes.

Note: To redo auto configuration for a relay containing less connections (binary inputs/outputs or sensors) than in previous memorized set-up, a dip-switch (anyone) must be moved back and forth prior to performing auto-configuration. Timeout allowing new configuration is one minute. Reconfiguration with more connections is allowed without moving a dip-switch.

3.4 Reset

All LED indications and latched trip relays are reset by pressing the SET button for one second. Otherwise, the latched trip relays will remain activated until auxiliary power is disconnected. All LED indications will remain active until a reset is performed by the operator, even in the case of disconnecting the auxiliary power supply (see Section 3.7: Non-volatile memory).

3.5 Current threshold setting

The EAFR-110PLV relay has four current measurement inputs utilized for three-phase and earth current measurement. Both phase current and earth current measurements are utilized as the second trip criteria in an arc protection system in order to avoid a trip caused by natural light sources. Phase over-current threshold is typically set 50 % above the highest load current (I_n). Earth fault over-current is very sensitive. Set points are set using potentiometers (see Figure 3). An accurate setting is obtained by injecting the desired set value using a relay test set to phase and earth current inputs of the EAFR-110PLV, simultaneously adjusting the potentiometers until phase and earth current indication LEDs are illuminated.

The setting range for the phase over-current stage is 0.5 to 6 $x I_n$. The setting range for earth fault over-current stage is 0.05 to 2 $x I_n$.



Figure 3. EAFR-110PLV over-current setting potentiometers.

3.6 Dipswitch settings

The EAFR-110PLV functionality, such as tripping logic, is configured using the dipswitch settings. The relay contains two switch groups SW1 and SW2 (see Figure 4). The dipswitches are located at the back of the relay for easy access.

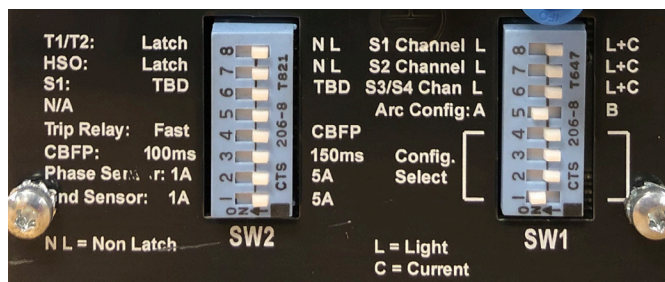

Figure 4. EAFR-110PLV dipswitches SW2 and SW1.

Different trip configurations can be easily programmed by selecting the appropriate dipswitch settings. The most convenient way to set the EAFR-110PLV single relay or more complex arc protection system is to use the Standard Arc Schemes for Arc Quenching Switchgear. For different arc schemes applications, see the Standard Arc Flash Relay Schematics for Arc Quenching Switchgear manual (IB0191003EN).

Tripping may be selected based on arc light only or current thresholds. The circuit breaker failure protection (CBFP) configuration may also be enabled using the dipswitches. See Table 2: EAFR-110PLV Dipswitch SW1 Setting and Table 3: EAFR-110PLV Dipswitch SW2 Setting for details of settings.

Table 2. EAFR-110PLV dipswitch SW1 setting.

Dipswitch	Function selection	ON (Left Position)	OFF (Right Position)
8 S1: Light / Light + Current	Sensor channel 1 trip criteria.	Trip on light only.	Trip on light and over-current. Both signals are required simultaneously to trip.
7 S2: Light / Light + Current	Sensor channel 2 trip criteria.	Trip on light only.	Trip on light and over-current. Both signals are required simultaneously to trip.
6 SX: Light / Light + Current.	Sensor channels 3 - 5 trip criteria (channel 3 in EAFR-110F)	Trip on light only.	Trip on light and over-current. Both signals are required simultaneously to trip.
5 a/b	Selection of standard arc configuration type.	Standard arc configurations type a.	Standard arc configurations type b.
4 Configuration select	Selection of standard arc configuration.	Refer to IB0191003EN.	Refer to IB0191003EN.
3 Configuration select	Selection of standard arc configuration.	Refer to IB0191003EN.	Refer to IB0191003EN.
2 Configuration select	Selection of standard arc configuration.	Refer to IB0191003EN	Refer to IB0191003EN
1 Configuration select	Selection of standard arc configuration.	Refer to IB0191003EN	Refer to IB0191003EN.

Table 3. EAFR-110PLV dipswitch SW2 setting.

Dipswitch	Function selection	ON (left position)	OFF (right position)
8 T1/T2: latch/non-latch	Latch or non-latch for trip relays T1 and T2.	T1 and T2 operate as latched.	T1 and T2 operate as non-latched.
7 HSO: latch/non-latch	Latch or non-latch for HSO1 and HSO2.	HSO1 and HSO2 operates as latched.	HSO1 and HSO2 operates as non-latched. Switch should always be set to this position when relay is used with EAFR-101C's.
6 S1: TBD	Reserved for future use.	N/A	N/A
5 S5: N/A	Arc quenching device output	N/A	Enables arc quenching device output. Switch should always be set to this position.
4 Fast / CBFP	Selection of trip relay T2 function.	Trip relay T2 will have 7 ms trip time.	Trip relay T2 will work as CBFP relay. If any sensor or light input (BI2) is activated for more than the set CBFP time (100 or 150 ms), the CBFP function activates the trip relay T2 and binary output B01. Note: Master trip command (BI2, see dipswitch 4) will not activate T2 when in CBFP mode
3 100 / 150 ms	CBFP time setting.	CBFP time is set to 100 ms.	CBFP time is set to 150 ms.
2 Phase sensor: 1A / 5A	Phase currents IL1, IL2, and IL3 nominal current selection.	1A nominal current.	5A nominal current.
1 Earth Ground sensor: 1A / 5A	Earth current ground sensor nominal current selection.	1A nominal current.	5A nominal current.

3.7 Non-volatile memory

All critical system data including dipswitch settings and the auto-configuration file described in Section 3.3.1 are stored in EPROM non-volatile memory to ensure correct operation and full self-supervision, even if auxiliary power is temporarily lost.

Also all LED indications described in Section 3.3.1 are stored in non-volatile memory in order to provide quick recovery of the system status indication even if auxiliary power is temporarily lost. This feature is especially important if auxiliary power is lost after tripping.

Non-volatile memory does not require a power supply to maintain information and will retain settings and indication information permanently without power.

4. Arc sensors

The EAFR-100 series provides the choice of different types of arc sensors to be utilized in different units and different switchgear types according to specific application requirements. Available sensor types are arc light point sensors and arc light fiber optic loop sensors.

Arc light point sensors are typically installed in metal clad compartments providing quick accurate location of the faulted area. Arc light fiber loop sensors are typically installed to cover a wider protected area with one fiber when no need for more exact fault location exists.

4.1 Arc light point sensor EAFR-01

The EAFR-01 is an arc light point sensor with a light sensitive photodiode element activated by arc light. EAFR-01 arc sensors should be mounted in the switchgear cubicles in such a way that the light sensitive part covers the protected area as completely as possible. One sensor per closed metal clad compartment should be utilized. In open spaces, such as the bus bar section, arc sensors should be mounted maximum 2 m (6.5 ft) apart.

The factory default set light sensitivity of the EAFR-01 sensor is 8,000 lux. This default set can be also designed as 25,000 and 50,000 lux according to the demand of user's application. The sensor does not require user settings. Detection radius is 180 degrees.

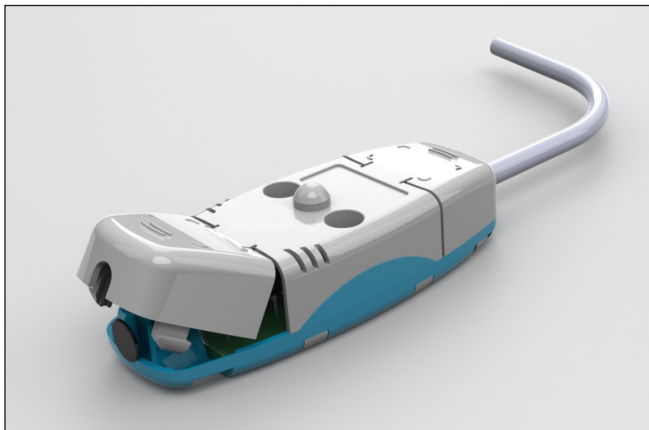

Figure 5. Arc light point sensor EAFR-01.

4.1.1 EAFR-01 installation and wiring

The EAFR-01 is installed either on the compartment wall or through the wall. An example of wall mounting is seen in Figure 6. The EAFR-01 is fixed to the wall using two screws. The same screw pattern is utilized in through wall mounting arrangement as well. The relay is turned around and the eye is pushed to the compartment to be protected. Two screws are attached from the back side of the sensor. No external mounting plates are needed in any case.



Figure 6. EAFR-01 point sensor mounted to the compartment wall.

The EAFR-01 comes without a connection cable. Connection cable installation at site is simple. The cable connectors are located beneath the covers of the sensor and can be conveniently detached for fastening the sensor wires. The covers will be reattached after installing the wires. Cable connectors are located at both ends of the sensor for series connecting a maximum three sensors in one line (see Figure 5).

4.1.2 Technical data for EAFR-01 point sensor

Table 4. Technical data for the EAFR point Sensor.

Light intensity threshold	8,000 Lux (EAFR-01-A), 25,000 Lux (EAFR-01-B), 50,000 Lux (EAFR-01-C)
Detection radius	180 degrees
Mechanical protection	IP 60
Sensor wiring arrangement	Two wires and shield
Sensor cable specification	Shielded, twisted pair 0.75 mm ²
Maximum sensor cable length per sensor channel	100 m (328 ft)
Operating temperature	-20 to 85°C (-4 to 185°F)

4.2 Sensor connection

4.2.1 Arc light point sensor EARF-01 connection

1. Open the sensor side covers and then detach the pluggable connectors from the sensor PCB and prepare the twisted shielded pair cable connecting (see Figure 7).

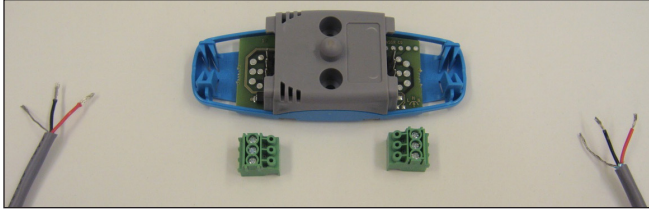

Figure 7. EAFR-01 sensor connection step 1.

2. Before connecting the cable to connector, make sure that the connecting order is correct (+, signal, shield). The appropriate pins information is shown on the blue bottom part of the sensor. Plug the wires into connector and fasten them by using a screw driver (see Figure 8).

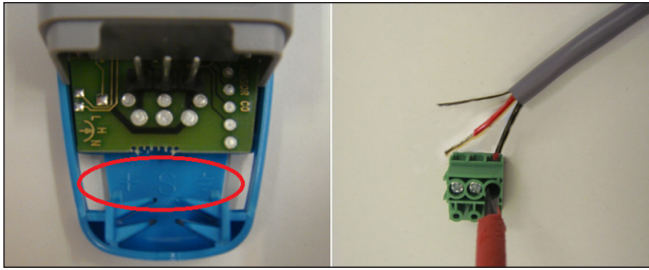

Figure 8. EAFR-01 sensor connection step 2.

3. Connect the other end of the cable to a sensor channel on the EAFR-101 or EAFR-110PLV relay (see Figure 9).

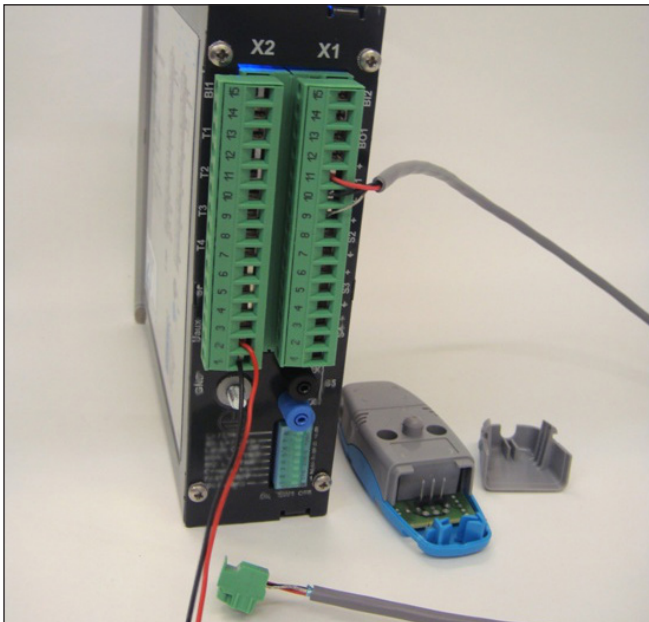

Figure 9. EAFR-01 sensor connection step 3.

4. Check the front panel of the relay. Only the POWER LED turns on at this moment (see Figure 10).

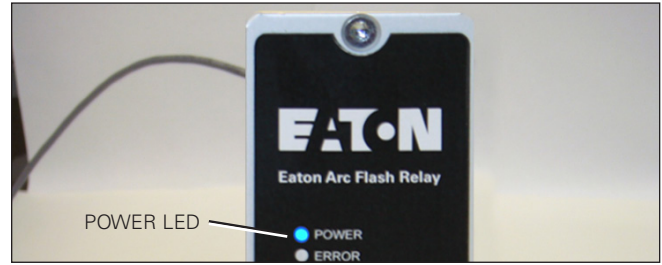

Figure 10. EAFR-01 sensor connection step 4.

5. Attach the connector back to the sensor PCB (see Figure 11).

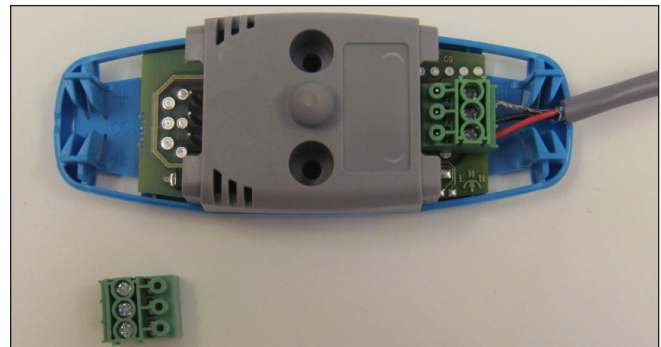

Figure 11. EAFR-01 sensor connection step 5.

6. After connecting the sensor to the relay, the ERROR LED turns on, and the appropriate sensor channel LED starts to blink (e.g. S1 LED) (see Figure 12).

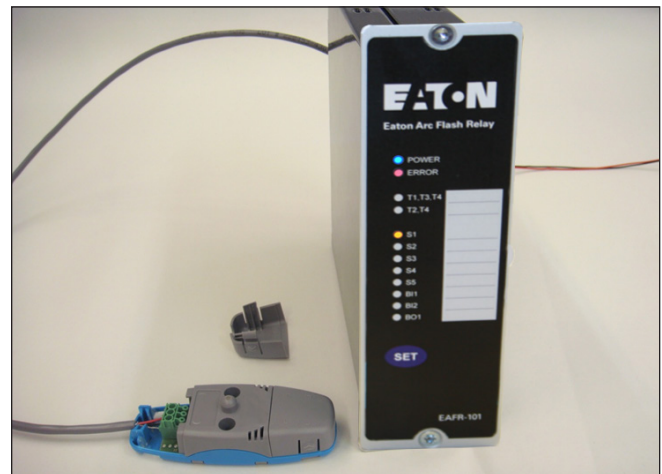

Figure 12. EAFR-01 sensor connection step 6.

7. Press and hold the SET push button on the front panel for two seconds in order to run the system auto-configuration setting (see Figure 13). The relay memorizes the sensor amount and binary input lines connected (if any).

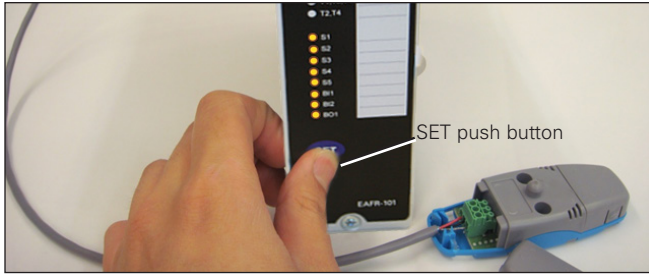

Figure 13. EAFR-01 sensor connection step 7.

8. After completing the system auto-configuration setting, close both end side covers back (see Figure 14).



Figure 14. EAFR-01 sensor connection step 8.

9. A maximum amount of three arc sensors can be daisy-chained to the same sensor input on the EAFR-101 relay (see Figure 15).

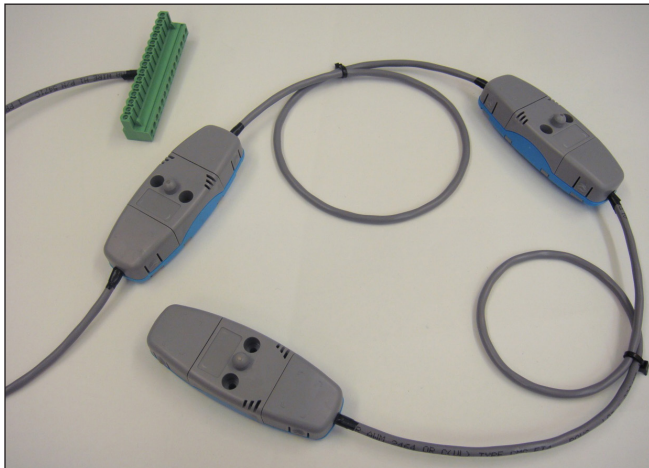

Figure 15. EAFR-01 sensor connection step 9.

Auto-configuration is a part of the self-supervision function which ensures that all connections and sensors are fully functional and ready to operate at all times.

5. System self-supervision

The EAFR-110PLV includes an extensive self-supervision feature. Self-supervision includes both internal functions and external connections. The self-supervision module monitors the power supply, HW malfunctions, SW malfunctions, the binary input connections, and sensor problems. Dipswitch settings are also supervised by comparing the actual values with stored non-volatile memory data (see Section 3.3.1: Auto configuration [System setup]).

In a healthy condition, the POWER LED is on and the system failure (SF) relay is energized. If the self-supervision function detects a faulty condition or the power supply fails, the self-supervision relay is released and the ERROR LED is illuminated.

If a fiber sensor failure occurs, the unit will go into Error mode. The ERROR LED will turn on, the SF relay will release, and the corresponding faulty fiber sensor channel LED will start blinking. In this situation, the unit is still in protection mode, but with the faulty fiber sensor channel blocked. If the error is resolved, the unit will automatically clear the SF-status. This means that the SF relay will energize and the ERROR LED will turn off. If one or more of the sensors are disconnected, the healthy sensors remain in use and unit remains operational accordingly. The EAFR-110PLV will remain in the Error mode until the disconnected sensors are repaired.

If a dipswitch setting is changed after the auto-configuration function (see Section 3.3.1: Auto configuration [System setup]) has been executed, the unit will go into SF-alarm mode. The configured (stored) setting is however still valid and the unit is still operational. The SF relay can be reset by pressing and holding the "SET" button for two seconds.

5.1 Open CT monitoring

If there is a current flow of more than $0.2 \times I_n$, the relay assumes that the switchgear is energized. In this case, phases IL1, IL2, and IL3 are monitored and supervised for open connection (no current flow).

If one or two of the three phases is 0 while the other(s) remain above $0.2 \times I_n$, the relay will issue an open CT alarm.

When an open CT alarm is issued, the SF-relay is released, the ERROR LED turned on, and corresponding IL1, IL2, and IL3 LEDs starts blinking.

6. Connections

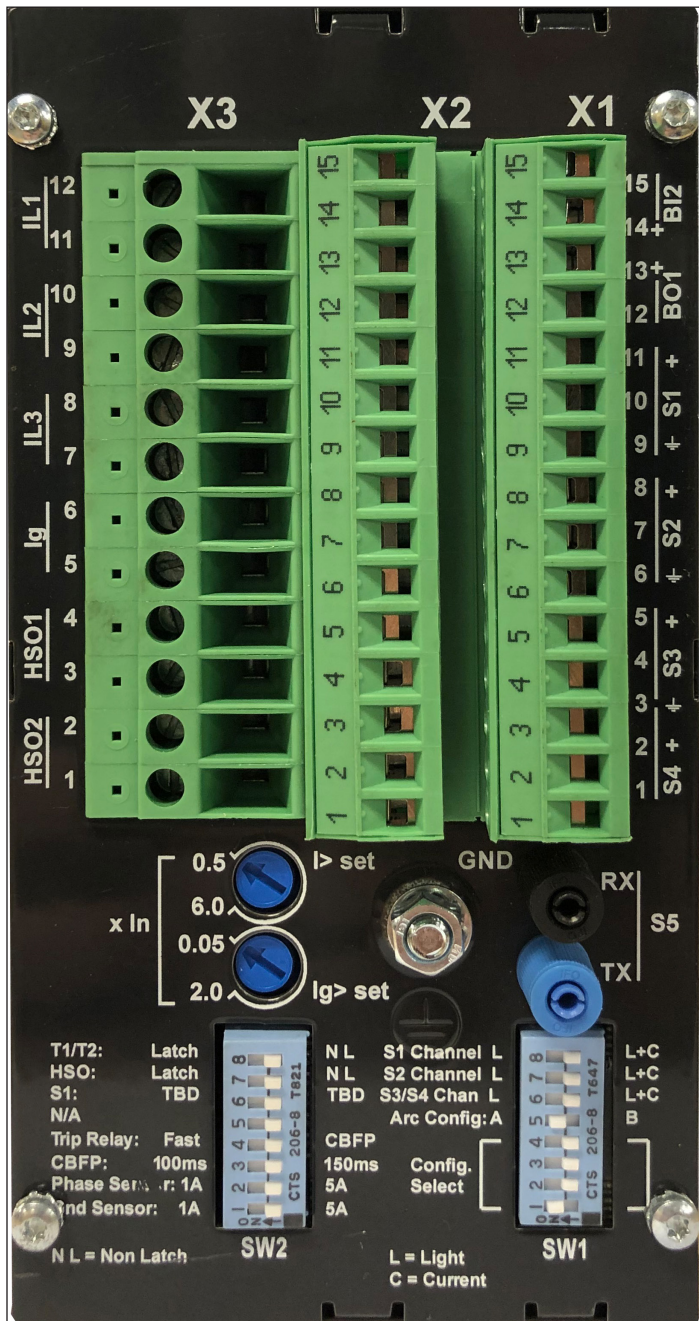

Figure 16. EAFR-110PLV terminals at the rear plate.

6.1 Outputs

6.1.1 Trip relays T1 and T2

The EAFR-110PLV relay has integrated trip relays T1 and T2 for tripping the circuit-breakers. T1 and T2 relays are normally open type (NO).

6.1.2 Trip relays T3 and T4

Trip relays T3 and T4 are not utilized in the EAFR-110PLV, and are reserved for future use.

6.1.3 High speed outputs (HSO1 and HSO2)

The EAFR-110PLV contains two high speed semiconductor outputs: HSO1 and HSO2. These outputs may be utilized either for direct

tripping of a circuit breaker or as heavy duty signaling outputs. Due to the high current carrying capacity, HSO1 and HSO2 are capable of supplying current information or a master trip signal to a maximum of 20 EAFR-100 series units without a need for signal amplifiers. HSO1 operation is dependent on the configuration select dials. For details see Section 3.6. HSO2 is also utilized as a synchronizing signal to any connected EAFR-101C relays. This connection is required for proper operation of the system if the EAFR-110PLV is connected to more than one EAFR-101C relay. This signal will not interfere with other operation of the HSO2 output.

6.1.4 Binary output BO1

One binary output is available (+24 Vdc). The binary output function can be configured using the dials (see Section 3.5: Dial settings).

Note: The binary output is polarity sensitive (see Section 7: Wiring diagram).

6.1.5 System failure relay SF

The system failure relay (SF) is a form C type (NO/NC) and is energized in the healthy condition. Whenever the EAFR-110PLV detects a system error or disconnection of the auxiliary power supply, the contact changes its state. The state of the SF relay remains the same until the relay returns to a healthy condition and the SF relay is energized again.

6.2 Inputs

6.2.1 Current measurement inputs

The EAFR-110PLV has four CT inputs for three-phase current and earth current measurement. Both phase current and earth current inputs may be configured to 1 or 5 amps nominal current input using dials (see Section 3.6: Dial settings). For setting current threshold levels refer to Section 3.5: Current threshold setting. An open circuit detection feature is included, for more details, refer to Section 5.1: Open CT monitoring.

6.2.2 Arc sensor channels S1, S2, S3, S4, and S5

The EAFR-110PLV has four arc point sensor channels (S1, S2, S3, and S4). A maximum three arc point sensors (type EAFR-01) may be connected to each channel.

S5 is a fiber optic I/O that is used as a fiber optic loop sensor input on other versions of the EAFR-110. The EAFR-110PLV uses the TX output of S5 for controlling the Arc Quenching Device. The relay sends a continuous light pulse to the arc quenching device for self-supervision purposes.

6.2.3 Binary Inputs (BI1 and BI2)

The EAFR-110PLV contains two binary inputs (BI1 and BI2). The function of binary inputs is selected using the dials according to standard arc configurations applications (see Section 3.6). Typically, binary inputs are utilized for receiving the arc light information from the EAFR-101 and EAFR-102 units, and receiving the over-current information from the other EAFR-110PLV devices. When EAFR-101C relays are used in conjunction with an EAFR-110PLV, BI2 is used as the input for light signals from the 101C relays. Each 101C relay sends its own continuous and specific health pulse to the 110PLV via BI2. Synchronization of these pulses is accomplished via connection to HSO2, as described in section 6.1.3.

The inputs are activated by connecting a dc signal exceeding the specified nominal threshold level of the corresponding input. The threshold level is 24Vdc. The actual activation of the binary input occurs at 80% of the specified nominal threshold value (i.e.: 19Vdc).

6.3 Auxiliary voltage

The auxiliary power supply voltage is (110-220) Vac / (125-250) Vdc.

After powering up, the relay protection is active and operational within 50 ms.

7. Wiring diagrams

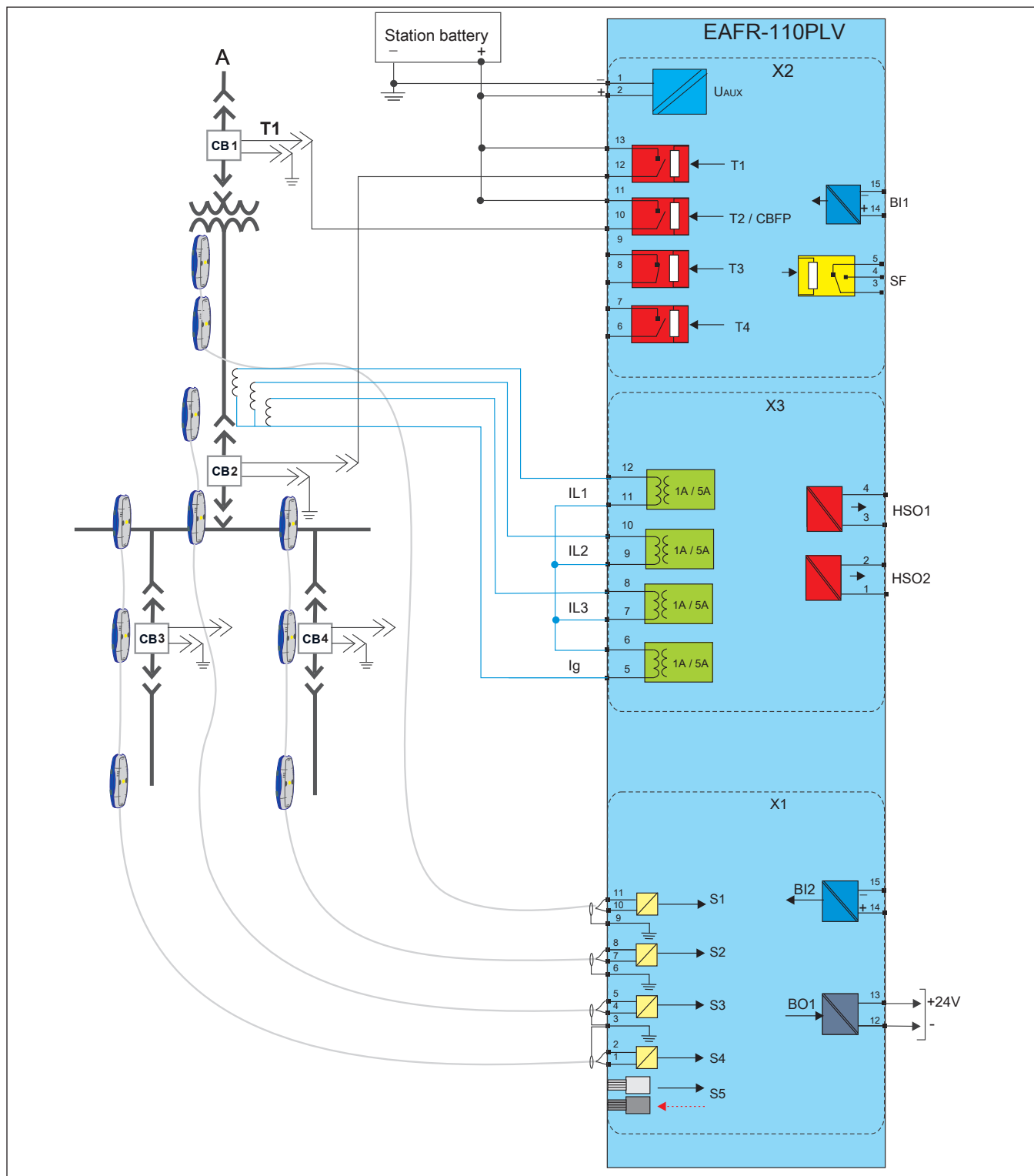

Figure 17. EAFR-110PLV wiring diagram.

8. Dimensions and installation

The EAFR-110PLV is door mounted in standard 19 in. (482.6 mm) rack (height of 4U and 1/4 of a relay wide).

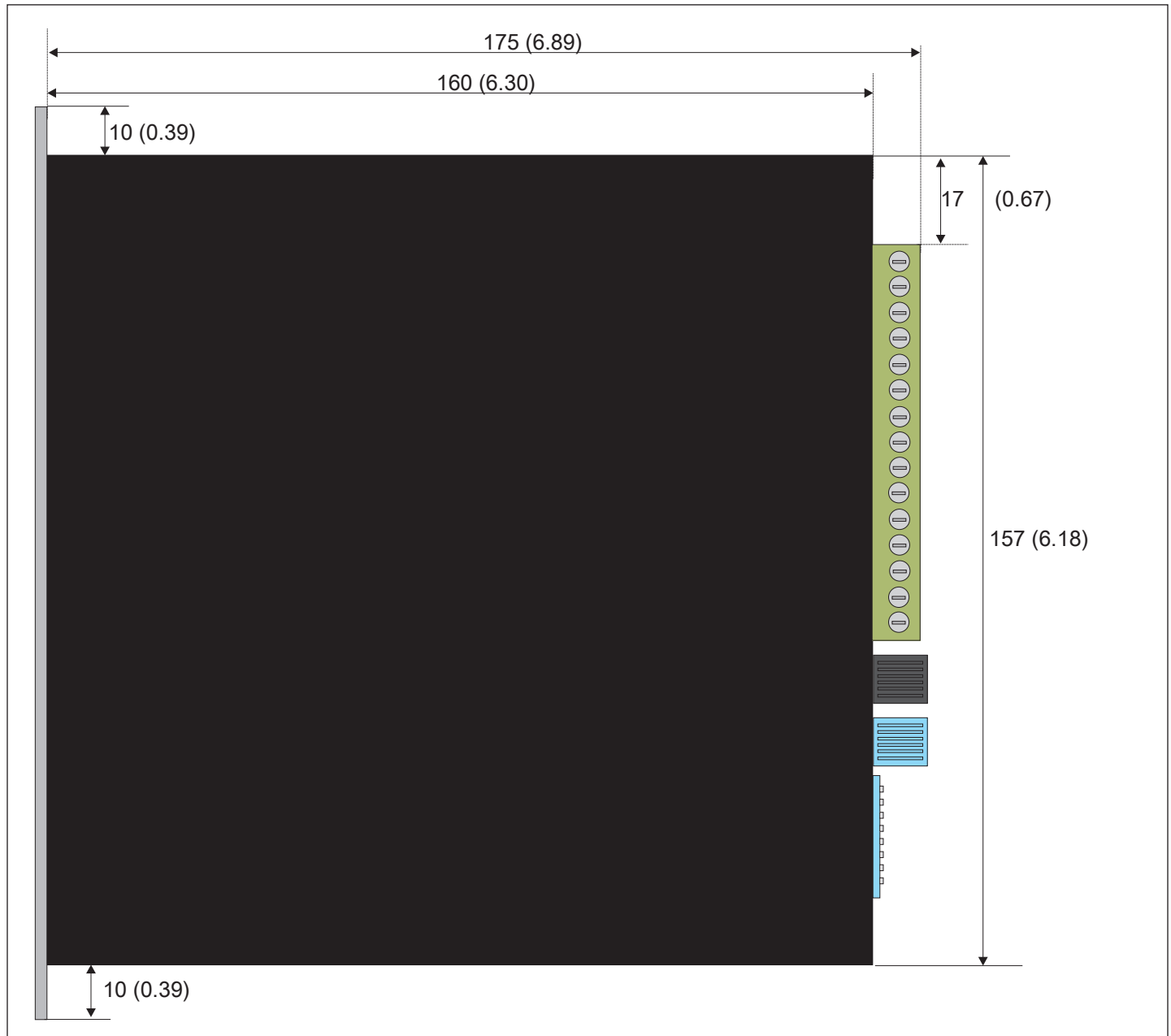

Figure 18. EAFR-102 dimensions in millimeters (in.) (side view).

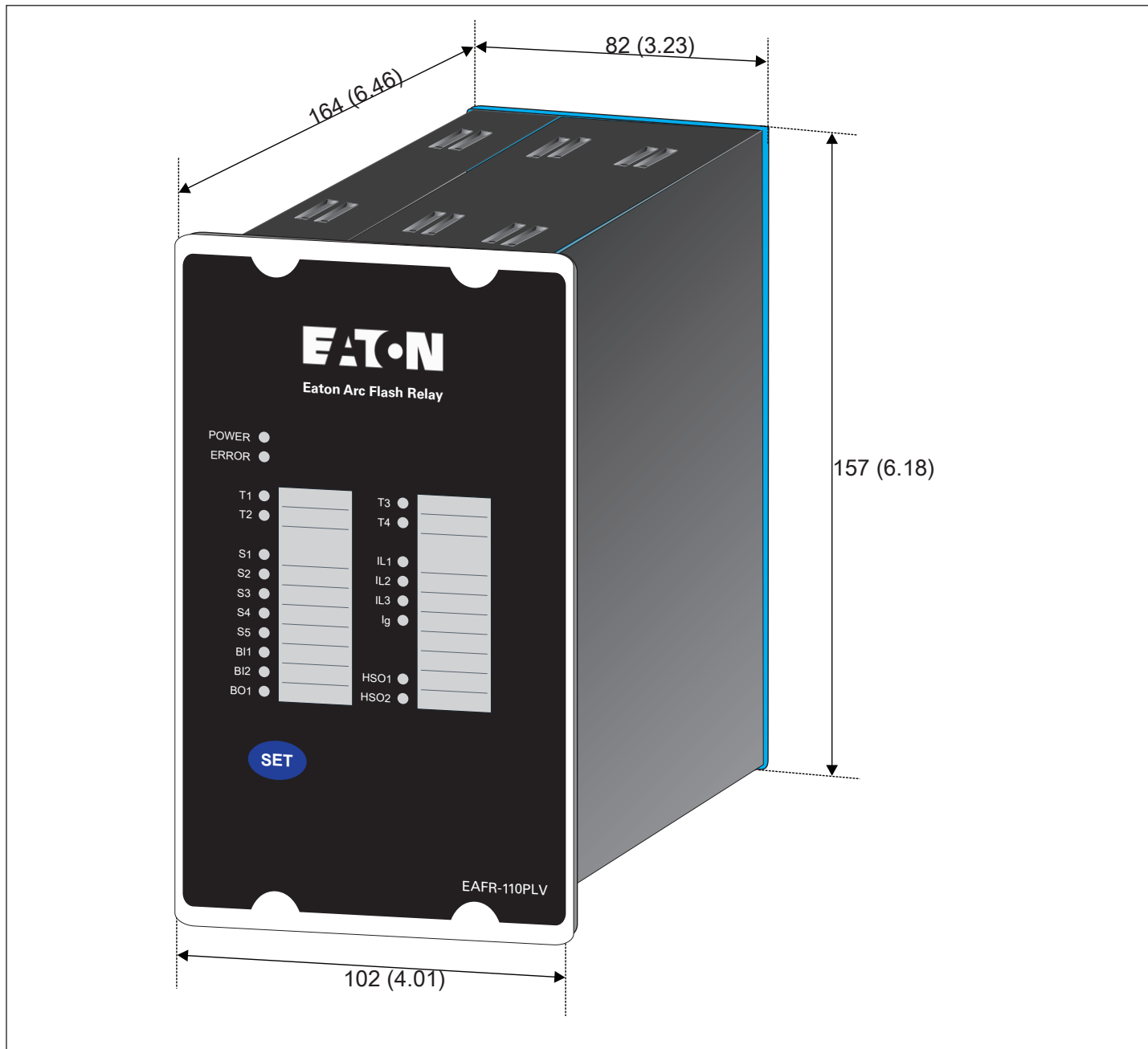

Figure 19. EAFR-110PLV dimensions in millimeters (inches) - 3-D view.

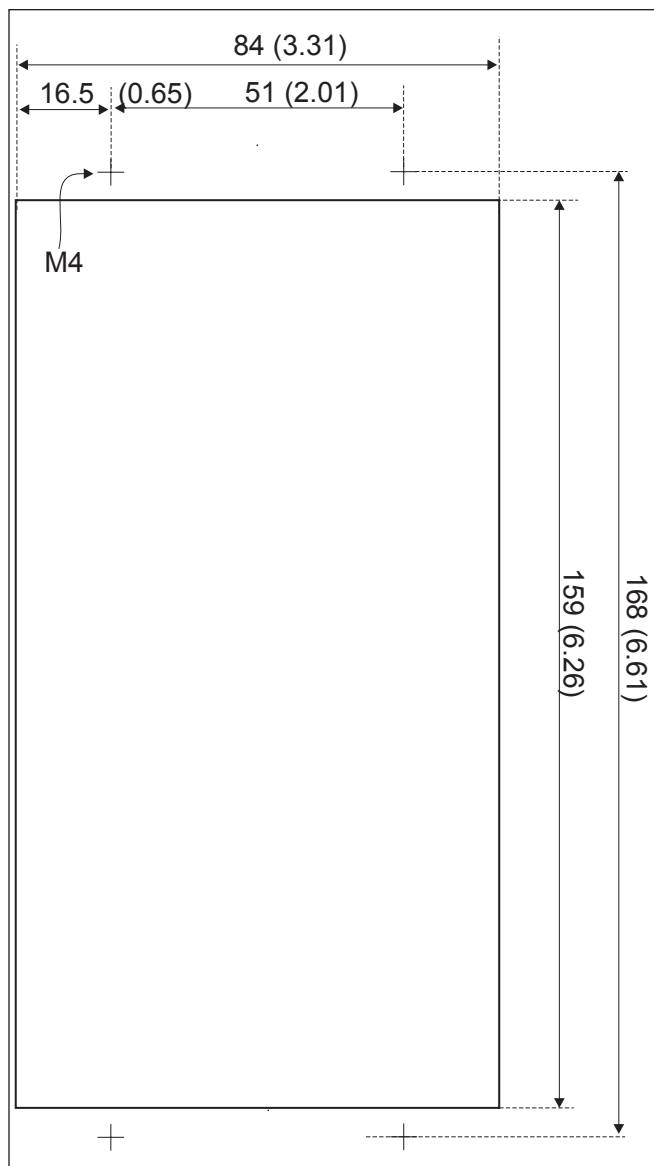

Figure 20. EAFR-110PLV cutout for panel mounting in millimeters (inches).

9. Testing

It is recommended that the EAFR-110PLV arc protection relay is tested prior to the equipment being energized. Testing is carried out by simulating arc light to each sensor and verifying the tripping and LED indication. For the arc light simulation, use a superior camera flash type: Canon Speedlite® 430EX or equivalent. For testing of non-latched signals and CBFP function, use a Mini Maglite® 2 Cell AAA or equivalent type of flashlight. Check that camera flash or flashlight has fully charged battery(ies) when testing.

9.1 Carrying out testing in the light only mode

1. Check that the dipswitch setting positions are in accordance to your application.
2. Activate the camera flash within 20 cm (8 in.) of the EAFR-01 sensor in use.
3. Verify that the corresponding sensor channel indication LED status is changed to ON.
4. Verify the relay output(s) activation(s) by checking the circuit breaker status or by monitoring the trip contact status. The circuit breaker should open or contacts operate.

Note: A best practice is to operate the circuit breaker during testing.

5. Verify that the corresponding relay output(s) LED(s) indication status is changed to ON.
6. If the binary output (BO1) or high speed output (HSO) signal is utilized, verify the BO1 or HSO signal activation by status change of relevant input where the output signal is connected or by measuring the signal output voltage. Note that the BO1 signal is a non-latched type.
7. If the BO1 or HSO signal is utilized, verify that the BO1 LED or relevant HSO LED is illuminated.
8. Press the SET push-button to reset all indications and latches.
9. If a binary input (BI2) is utilized as master trip to activate the corresponding binary input, verify that the trip has occurred by repeating Steps 4 and 5.
10. Press the SET push-button to reset all indications and latches.
11. Repeat the testing procedure for all sensors.

9.2 Carrying out testing in light and current mode

1. Check that the dipswitch setting positions are in accordance with your application.
2. Activate the camera flash within 20 cm (8 in.) of the EAFR-01 sensor relay and simultaneously activate the binary input BI1 used for over-current condition.
3. Verify that the sensor channel indication LED status is changed to ON.
4. Verify that the binary input indication LED status is changed to ON.
5. Verify the relay output(s) activation(s) by checking the circuit breaker status or by monitoring trip contact status.

Note: A best practice is to operate circuit breaker at testing. The circuit breaker should open or contacts operate.

6. Verify that the corresponding relay output(s) LED(s) indication status is changed to ON.
7. If the binary output (BO1) signal is utilized, verify the BO1 signal activation by the status change of the relevant input where the binary output signal is connected, or by measuring the signal output voltage.
8. If a binary output or high speed output (HSO) signal is utilized, verify that BO1 LED or the relevant HSO LED is illuminated. Note that the BO1 signal is a non-latched type.
9. If the other binary input (BI2) is in use, verify correct operation by activating the input.
10. Activate the camera flash within 20 cm (8 in.) from the EAFR-01 sensor relay and do not activate the binary input used for over-current condition.
11. Verify that no trip has occurred and only the sensor activation indication LED is ON.
12. Verify that the BO1 signal is activated (if in use and configured to send light information).
13. Press the SET push-button to reset all indications and latches.
14. If the binary input BI2 is utilized for master trip to activate the BI2, verify that a trip has occurred by repeating steps 4 and 5.
15. Press the SET push-button to reset all indications and latches.
16. Repeat the testing procedure for all sensors.

9.3 Testing the CBFP function

The circuit breaker failure function is tested by leaving light signal and second trip criteria signal (e.g. over-current), if applicable, active for above the set CBFP time of either 100 or 150 ms. The trip relay T2 and binary output BO1 should be active after the set time delay.

9.4 Testing the arc flash protection unit operation time

The EAFR-110PLV operation time test is not required at commissioning as it is performed by the manufacturer as a type test and routine production test. Refer to the routine test reports sent with EAFR-110PLV relay and consult your nearest Eaton representative for type test reports.

However, if it is deemed necessary, a site timing test may be conducted using the instructions that follow.

1. Use a calibrated relay test set.
2. Connect an output from the relay test set to the camera flash or equivalent input for initializing the flash and configure a relay test set timer to be started simultaneously with flash.
3. Connect EAFR-110PLV trip output T1,T2, or high speed outputs HSO1 or HSO2 to relay test set input and configure the input to stop the timer.
4. Place camera flash to maximum 20 cm (8 in.) distance of the EAFR-01.
5. Initiate the flash and timer using the relay test set output.
6. Read the measured time between simulated arc and trip contact operation.
7. Subtract the digital input delay of the relay test set from the final measured time if applicable. For specific test instructions consult the manufacturer of the relay test set.

9.5 Relay self-check of input connections

The EAFR-110PLV has a user-initiated self-check test feature that gives the user feedback as to the number of external devices connected to each input on the relay. This feature is particularly helpful in troubleshooting, or in verifying that the relay has correctly identified any external connected devices, such as light sensors or other relays.

To initiate this test, press the Set button three times quickly. One at a time, the LED for each input will blink for the number of devices connected to that input. For example, if three light sensors are connected to S1, then the LED for S1 will blink three times. The relay continues this function until feedback has been given for all inputs. The relay remains operational during this test, and at no time is the protective function compromised.

9.5 Test plan example

Date: _____

Substation: _____

Switchgear: _____

EAFR-110PLV serial number: _____

Preconditions	Light only	Light + current	Remarks
Sensor channel 1 setting			
Sensor channel 2,3,4 setting			
Circuit breaker failure protection (CBFP) in use (yes / no):			

Object activated	LED indication	T1, and T2. active	BO1 active
Sensor channel 1	Sensor 1		
	Sensor 2		
	Sensor 3		
Sensor channel 2	Sensor 1		
	Sensor 2		
	Sensor 3		
Sensor channel 3	Sensor 1		
	Sensor 2		
	Sensor 3		
Sensor channel 4	Sensor 1		
	Sensor 2		
	Sensor 3		
Fiber sensor channel (option)			
BIN 1			
BIN 2			
Phase current IL1, IL2, and IL3			
Earth current Ig			

Tested by: _____

Approved by: _____

10. Troubleshooting guide

Table 5. Troubleshooting guide.

Problem	Check	Cross reference
Sensor does not activate when testing.	Sensor cable wiring.	Section 4.6 of this manual
	Camera (or other test equipment) flash intensity.	Section 9 of this manual
Trip relay(s) does not operate even if sensor is activated.	Dipswitch settings and current threshold set-points.	Section 3.6 and 6 of this manual.
Current measurement indicator LED is continuously on.	Current threshold set-points.	Section 3.5 of this manual.
Current measurement indicator LED is blinking.	Proper connection of three phase currents.	Section 5.1 of this manual.

11. Technical data

11.1 Protection stages

Trip time using HSO	2 ms*
Trip time using mechanical trip relays	7 ms*
Trip time for ADQ output	1.8ms*
Reset time (light stage)	1 ms
Reset time (over-current stages)	50 ms
Protection operational after power up	50 ms

* = Total trip time using arc light or phase/earth over-current from EAFR-110PLV and arc light.

11.2 Auxiliary voltage

Vaux	(110-220) Vac / (125-250) Vdc ± 20%
Maximum interruption	100 ms
Maximum power consumption	5 W, <10 mΩ
Standby Ccurrent	90 mA

11.3 Current measuring circuits

Nominal current	1 or 5 A
Rated frequency	2 to 1,000 Hz
Number of inputs	3 (phase) + 1 (earth)
Thermal withstand continuous	30 A
Thermal withstand 1 s	500 A
Thermal withstand 10 s	100 A
Phase over-current setting range	0.5 to 6* In
Earth over-current setting range	0.05 to 2 *In
Measurement accuracy	10%
Rated AC burden (VA)	Input resistance 10 mΩ
Power consumption of current inputs circuit	<10 mΩ

11.4 Trip relays T1 and T2

Number	3 NO + 1 NC or 4 NO
Rated voltage	250 Vac/dc
Continuous carry	5 A
Make and carry for 0.5 s	30 A
Make and carry for 3 s	16 A
Breaking capacity DC, when time constant L/R = 40 ms	40 W; 0.36 A at 110 Vdc
Contact material	AgNi 90/10

11.5 High speed outputs HSO1 and HSO2

Number	2
Rated voltage	250 Vdc
Continuous carry	2 A
Make and carry for 0.5 s	15 A
Make and carry for 3s	6 A
Breaking capacity DC, when time constant L/R = 40 ms	1 A / 110 W
Contact material	Semiconductor

11.6 Binary output BO1

Rated voltage	+24 Vdc
Rated current	20 mA (max)
Number of outputs	1

11.7 Binary inputs BI1 and BI2

Rated voltage	24
Rated current	3 mA
Number of inputs	2

11.8 Disturbance tests

EMC test	CE approved and tested according to EN 50081-2, EN 50082-2.
Emission	
- Conducted (EN 55011 class A)	0.15 - 30 MHz
- Emitted (EN 55011 class A)	30 - 1 000 MHz
Immunity	
- Static discharge (ESD) (according to IEC244-22-2 and EN61000-4-2, class III)	Air discharge 15 kV. Contact discharge 8 kV.
- Fast transients (EFT) (according to EN61000-4-4, class III and IEC801-4, level 4)	Power supply input 4 kV, 5/50 ns Other inputs and outputs 4 kV, 5/50 ns
- Surge (according to EN61000-4-5 [09/96], level 4)	Between wires 2 kV / 1.2/50 μs. Between wire and earth 4 kV / 1.2/50 μs.
- RF electromagnetic field test (according. to EN 61000-4-3, class III)	f = 80 to 1,000 MHz 10 V / m
- Conducted RF field (according. to EN 61000-4-6, class III)	f = 150 kHz to 80 MHz 10 V

11.9 Voltage tests

Insulation test voltage Acc - to IEC 60255-5	2 kV, 50 Hz, 1 min
Impulse test voltage Acc - to IEC 60255-5	5 kV, 1.2/50 us, 0.5 J

11.10 Mechanical tests

Vibration test	2 to 13.2 Hz ± 3.5 mm (0.14 in.) 13.2 to 100 Hz, ± 1.0 g (0.04 oz)
Shock/bump test acc. to IEC 60255-21-2	20 g, 1,000 bumps/dir.

11.11 Casing and package

Protection degree (front)	IP 50
Protection degree (back)	IP 20
Dimensions - W x H x D mm (W x H x D in.)	102 x 157 x 164 mm (4.02 x 6.18 x 6.46 in.)
Package dimensions(W x H x D) mm (in.)	230 x 120 x 210 mm (9.06 x 6.18 x 6.46 in.)
Weight	0.7 kg (24.69 oz) 1.0 kg (35.27 oz) (with package)

11.12 Environmental conditions

Specified ambient service temp. range	-35 to +70°C (-31 to 158°F)
Transport and storage temp. range	-40 to +70°C (-40 to 158°F)
Relative humidity	Up to 97%

12. Ordering codes

12.1 EAFR relay codes

Eaton catalog number	Eaton style number	Part number description
EAFR-110P	65C2010G01	Current, point sensor unit
EAFR-110F	65C2010G02	Current, fiber loop sensor unit
EAFR-101	65C2010G03	Point sensor unit
EAFR-101D	65C2010G04	Point sensor unit, DIN rail mounted
EAFR-102	65C2010G06	Fiber loop sensor unit
EAFR-110PB	65C2010G07	Current, point sensor relay, NC trip relay
EAFR-110FB	65C2010G08	Current, fiber loop sensor relay, NC trip relay
EAFR-101B	65C2010G09	Point sensor relay, NC trip relay
EAFR-101DB	65C2010G10	Point sensor relay, DIN rail mounted, NC trip relay
EAFR-102B	65C2010G11	Fiber loop sensor relay, NC trip relay
EAFR-101C	65C2010G18	Point sensor unit with circuit breaker inputs
EAFR-110PLV	65C2010G17	Current, point sensor, AQD unit
EAFR-110PLV-B	65C2010G19	Current, point sensor, AQD unit, 24Vdc supply

2.2 EAFR-0x arc sensors

Eaton catalog number	Eaton style number	Part number description
EAFR-01-A	65C2011G01	Arc light point sensor - 8,000 Lux
EAFR-01-B	65C2011G02	Arc light point sensor - 25,000 Lux
EAFR-01-C	65C2011G03	Arc light point sensor - 50,000 Lux
EAFR-06-10	65C2013G01	Arc light plastic fiber sensor - 10 m (32.81 ft)
EAFR-06-15	65C2013G02	Arc light plastic fiber sensor - 15 m (49.21 ft)
EAFR-06-20	65C2013G03	Arc light plastic fiber sensor - 20 m (65.62 ft)
EAFR-06-25	65C2013G04	Arc light plastic fiber sensor - 25 m (82.02 ft)
EAFR-06-30	65C2013G05	Arc light plastic fiber sensor - 30 m (93.43ft)
EAFR-06-35	65C2013G06	Arc light plastic fiber sensor - 35 m (114.83 ft)
EAFR-06-40	65C2013G07	Arc light plastic fiber sensor - 40 m (131.23 ft)
EAFR-07-10	65C2014G01	Arc light glass fiber sensor - 10 m (32.81 ft)
EAFR-07-15	65C2014G02	Arc light glass fiber sensor - 15 m (49.21 ft)
EAFR-07-20	65C2014G03	Arc light glass fiber sensor - 20 m (65.62 ft)
EAFR-07-25	65C2014G04	Arc light glass fiber sensor - 25 m (82.02 ft)
EAFR-07-30	65C2014G05	Arc light glass fiber sensor - 30 m (93.43ft)
EAFR-07-35	65C2014G06	Arc light glass fiber sensor - 35 m (114.83 ft)
EAFR-07-40	65C2014G07	Arc light glass fiber sensor - 40 m (131.23 ft)
EAFR-07-45	65C2014G08	Arc light glass fiber sensor - 45 m (147.64 ft)
EAFR-07-50	65C2014G09	Arc light glass fiber sensor - 50 m (164.05 ft)
EAFR-08-10	65C2015G01	Arc light glass fiber sensor (high temperature) - 10 m (32.81 ft)
EAFR-08-15	65C2015G02	Arc light glass fiber sensor (high temperature) - 15 m (49.21 ft)
EAFR-08-20	65C2015G03	Arc light glass fiber sensor (high temperature) - 20 m (65.62 ft)
EAFR-08-25	65C2015G04	Arc light glass fiber sensor (high temperature) - 25 m (82.02 ft)
EAFR-08-30	65C2015G05	Arc light glass fiber sensor (high temperature) - 30 m (93.43ft)
EAFR-08-35	65C2015G06	Arc light glass fiber sensor (high temperature) - 35 m (114.83 ft)
EAFR-08-40	65C2015G07	Arc light glass fiber sensor (high temperature) - 40 m (131.23 ft)
EAFR-08-45	65C2015G08	Arc light glass fiber sensor (high temperature) - 45 m (147.64 ft)
EAFR-08-50	65C2015G09	Arc light glass fiber sensor (high temperature) - 50 m (164.05 ft)

DISCLAIMER OF WARRANTIES AND LIMITATION OF LIABILITY

The information, recommendations, descriptions and safety notations in this document are based on Eaton Corporation's ("Eaton") experience and judgment and may not cover all contingencies. If further information is required, an Eaton sales office should be consulted. Sale of the product shown in this literature is subject to the terms and conditions outlined in appropriate Eaton selling policies or other contractual agreement between Eaton and the purchaser.

THERE ARE NO UNDERSTANDINGS, AGREEMENTS, WARRANTIES, EXPRESSED OR IMPLIED, INCLUDING WARRANTIES OF FITNESS FOR A PARTICULAR PURPOSE OR MERCHANTABILITY, OTHER THAN THOSE SPECIFICALLY SET OUT IN ANY EXISTING CONTRACT BETWEEN THE PARTIES. ANY SUCH CONTRACT STATES THE ENTIRE OBLIGATION OF EATON. THE CONTENTS OF THIS DOCUMENT SHALL NOT BECOME PART OF OR MODIFY ANY CONTRACT BETWEEN THE PARTIES.

In no event will Eaton be responsible to the purchaser or user in contract, in tort (including negligence), strict liability or otherwise for any special, indirect, incidental or consequential damage or loss whatsoever, including but not limited to damage or loss of use of equipment, plant or power system, cost of capital, loss of power, additional expenses in the use of existing power facilities, or claims against the purchaser or user by its customers resulting from the use of the information, recommendations and descriptions contained herein. The information contained in this manual is subject to change without notice.

Eaton
1000 Eaton Boulevard
Cleveland, OH 44122
United States
Eaton.com

© 2021 Eaton
All Rights Reserved
Printed in USA
Publication No. IB0191004EN / TBG 001494
February 2021