

SIEMENS

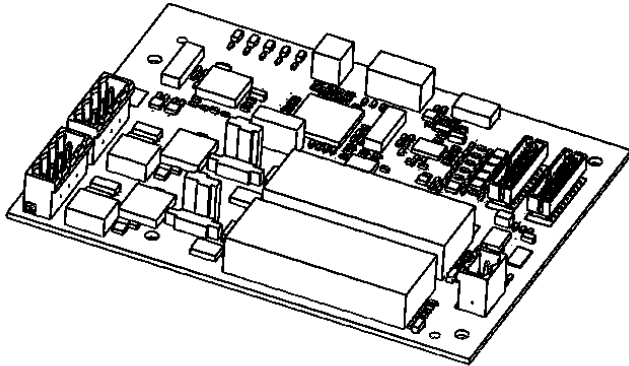

FCA2015-U1

Serial Digital Alarm Communicator Transmitter (DACT)

Installation Instruction

Legal Notice

Technical specifications and availability subject to change without notice.

© 2020 Copyright by Siemens Industry, Inc.

Transmittal, reproduction, dissemination and/or editing of this document as well as utilization of its contents and communication thereof to others without express authorization are prohibited. Offenders will be held liable for payment of damages. All rights created by patent grant or registration of a utility model or design patent are reserved.

Issued by:

Siemens Industry, Inc.

Smart Infrastructure

8 Fernwood Road

Florham Park, NJ 07932

Tel. + 1 973- 593-2600

www.downloads.siemens.com/dlc

Edition: 2020-10-14

Document ID: A6V10334254_en--_h

Cyber security disclaimer

Siemens provides a portfolio of products, solutions, systems and services that includes security functions that support the secure operation of plants, systems, machines and networks. In the field of Building Technologies, this includes building automation and control, fire safety, security management as well as physical security systems.

In order to protect plants, systems, machines and networks against cyber threats, it is necessary to implement – and continuously maintain – a holistic, state-of-the-art security concept. Siemens' portfolio only forms one element of such a concept. You are responsible for preventing unauthorized access to your plants, systems, machines and networks which should only be connected to an enterprise network or the internet if and to the extent such a connection is necessary and only when appropriate security measures (e.g. firewalls and/or network segmentation) are in place. Additionally, Siemens' guidance on appropriate security measures should be taken into account. For additional information, please contact your Siemens sales representative or visit <https://www.siemens.com/global/en/home/company/topicareas/future-of-manufacturing/industrial-security.html>.

Siemens' portfolio undergoes continuous development to make it more secure. Siemens strongly recommends that updates are applied as soon as they are available and that the latest versions are used. Use of versions that are no longer supported, and failure to apply the latest updates may increase your exposure to cyber threats. Siemens strongly recommends to comply with security advisories on the latest security threats, patches and other related measures, published, among others, under <https://www.siemens.com/cert/en/cert-security-advisories.htm>.

Table of Contents

OVERVIEW 6

INSTALLATION ON DESIGO AND CERBERUS PRO PANELS 6

INSTALLATION ON XLS/DESIGO FIRE SAFETY MODULAR/CERBERUS PRO MODULAR 7

FIRMWARE UPDATE ON XLS/DESIGO FIRE SAFETY MODULAR/CERBERUS PRO MODULAR SYSTEMS 7

FCA2015-U1 WIRING 7

FCA2015-U1 FORMAT DESCRIPTION 8

COMPATIBLE RECEIVERS/FORMATS 8

COMPATIBLE ALARM COMMUNICATORS 9

ULC PASSIVE CONFIGURATION 11

LE4010-CF CONFIGURATION 12

TL300-CF CONFIGURATION 12

LE4010-CF & TL300-CF POWER SUPPLY WIRING CONFIGURATION 13

FCA2015-U1 EVENT CODES 14

FCC Statement 16

NOTICE TO USERS, INSTALLERS, AUTHORITIES HAVING JURISDICTION, AND OTHER INVOLVED PARTIES

This product incorporates field-programmable software. In order for the product to comply with the requirements in the Standard for Control Units and Accessories for Fire Alarm Systems, UL 864, certain programming features or options must be limited to specific values or not used at all as indicated below.

Program feature or option	Permitted in UL 864? (Y/N)	Possible settings	Settings permitted in UL 864
PERIODIC TEST, PROGRAMMING RANGE	Y	1 – 24 Hours	1 – 6 Hours
Digital Communication format	Y	SIA DCS, Ademco Contact ID, 3/1, 4/2	SIA DCS, Ademco Contact ID

NOTICE TO USERS, INSTALLERS, AUTHORITIES HAVING JURISDICTION, AND OTHER INVOLVED PARTIES

This product incorporates field-programmable software. In order for the product to comply with the requirements in CAN/ULC-S527, Standard for Control Units and Accessories for Fire Alarm Systems, certain programming features or options must be limited to specific values or not used at all as indicated below.

Program feature or option	Permitted in CAN/ULC-S527? (Y/N)	Possible settings	Settings permitted in CAN/ULC-S527
PERIODIC TEST, PROGRAMMING RANGE	Y	1 – 24 Hours	1 – 24 Hours
Digital Communication format	Y	CID, SIA DCS	SIA DCS, Ademco Contact ID

OVERVIEW

The FCA2015-U1 Digital Alarm Communicator Transmitter (DACT) Board is an optional module for the Desigo FC2025/2050, FV2025/2050, Cerberus PRO FC922/924, FV922/924, and XLS/Desigo Fire Safety Modular/Cerberus PRO Modular Fire Alarm System Control Panels. The DACT provides telephone line connections for communication with a DACR (Digital Alarm Communicator Receiver). The DACT Board is mounted inside the Fire Alarm cabinet. The DACT Board options are set through the control panel programming sequence.

INSTALLATION ON DESIGO AND CERBERUS PRO PANELS

Dialer FCA2015-U1 mounted on 2HU Enclosure

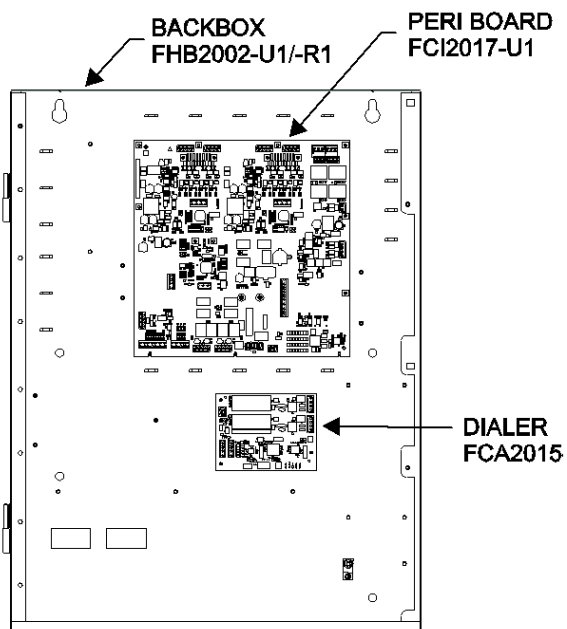

- Step 1) Installation should be performed by qualified personnel who have thoroughly read and understood this instruction sheet.
 - Step 2) Disconnect BATTERY and AC on the cabinet prior to working on the equipment.
 - Step 3) Mount FCA2015-U1 as shown using the four screws that are supplied.
 - Step 4) Attach conduit and run wires as required. Wire Size: 12-22AWG
 - Step 5) Connect the Serial Communication Cable to the fire system control unit as required.
 - Step 6) Apply power to system.
 - Step 7) Program for proper operation.
- NOTE:** See the Desigo FC2025/2050, FV2025/2050 Configuration manual, Document ID A6V10315023, and Cerberus PRO FC922/924, FV922/924 Fire Detection System Configuration manual, Document ID A6V10333423, for details on programming.
- Step 8) Check for proper operation.

Dialer FCA2015-U1 mounted on the back of the inner door (when used with a 3HU Enclosure)

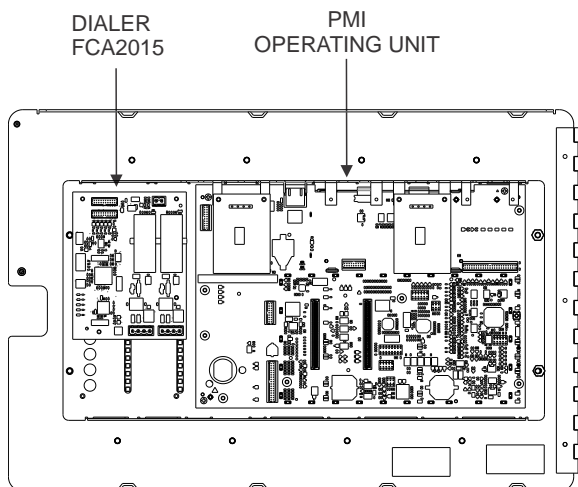

PARTS SUPPLIED

- 1 DACT Board
- 4 Screws
- 1 Instruction Sheet
- 1 Serial Communication Cable
- *4 1 ¼" x ¼" Hex Male to Female Standoff

*Used for FCM2019-U2/-U3 or FCM2035-U2/-U3 only.

INSTALLATION ON XLS/DESIGO FIRE SAFETY MODULAR/CERBERUS PRO MODULAR

For instructions on installing and wiring the FCA2015-U1 DACT to the XLS/Desigo Fire Safety Modular/Cerberus PRO Modular panel, refer to the XDACT-ASSY Installation Instructions, Document ID A6V10807278.

If a message indicating an XDACT firmware mismatch is displayed on the Operator Interface (OI), upgrade the XDACT firmware as follows.

FIRMWARE UPDATE ON XLS/DESIGO FIRE SAFETY MODULAR/CERBERUS PRO MODULAR SYSTEMS

To update the firmware on an FCA2015-U1 that is installed on a XLS/Desigo Fire Safety Modular/Cerberus PRO Modular system, establish an Ethernet connection between the PC and the OI, then select the XDACT module in the Zeus configuration. Next, select **Build > Transfer > Module Firmware To Panel...** in Zeus. Select the XDACT firmware file under **Firmware File**, then set the Connection Settings as needed and click **Start Transfer** to begin the update. **Transfer Completed** will be displayed in Zeus after the firmware update has completed.

FCA2015-U1 WIRING

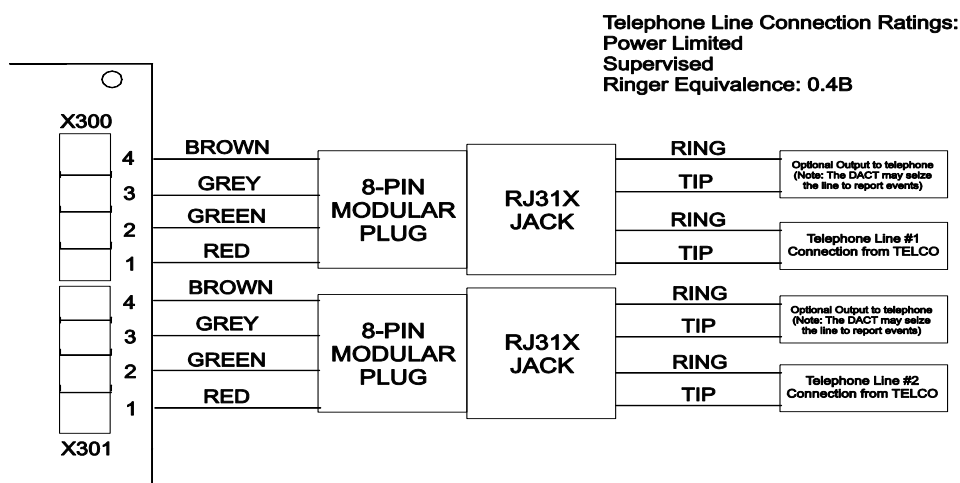

NOTE: The RJ31X provides a convenient connection allowing the DACT to be installed and removed without requiring re-wiring and can be installed by the telephone installer.

NOTE: If installed in Canada, the signal receiving centre must not share a common communication channel with the protected premises. A dedicated line must be installed for use only by the FCA2015-U1.

NOTE: Either of the two lines at X300 or X301 can be disabled using the Engineering Configuration tool for the case where the dialer is connected to an alarm communicator that is capable of transmitting with two separate technologies (ex. GSM and POTS). Consult the installation instructions for the communicator to determine if it supports this capability.

FCA2015-U1 FORMAT DESCRIPTION

Format	Description
SIA DCS 8	Security Industry Association - Digital Communications Standard (DCS). Format may send up to eight events per call. SIA 1997 Level 1 compatibility with support for O (old) blocks and 300 Baud (FAST) operation. Sends an account number (up to 6 digits), a 2-character code and 3-digit identifier up to four times with FSK frequency encoding.
SIA DCS 20	See SIA DCS 8, except format may send up to twenty events per call.
Ademco Contact ID	Sends a 4-digit account number, a 3-digit code and 3-digit identifier up to four rounds of dual tone multiple frequency with 1400 and 2300 Hz handshake frequency.
3/1 1400HZ	Sends a 3-digit account number and a 1-digit code up to four rounds at 20 pps with 1400 Hz handshake frequency.
3/1 2300HZ	Sends a 3-digit account number and a 1-digit code up to four rounds at 20 pps with 2300 Hz handshake frequency.
4/2 1400HZ	Sends a 4-digit account number and a 2-digit code up to four rounds at 20 pps with 1400 Hz handshake frequency.
4/2 2300HZ	Sends a 4-digit account number and a 2-digit code up to four rounds at 20 pps with 2300 Hz handshake frequency.

COMPATIBLE RECEIVERS/FORMATS

Receiver Manufacturer	Compatible Receivers	SIA DCS 8	SIA DCS 20	Ademco Contact ID	3/1 1400HZ	3/1 2300HZ	4/2 1400HZ	4/2 2300HZ
Honeywell	M8000	SIA DCS 8	SIA20	Ademco Contact ID	SK 3/1	SK 3/1	SK 4/2	SK 4/2
Bosch	D6100i, D6100IPV6, or D6600	SIA DCS 8	SIA20	Ademco Contact ID	SK 3/1	SK 3/1	SK 4/2	SK 4/2
Silent Knight Security Corp.	9800	X	X	Ademco Contact ID	SK 3/1	SK 3/1	SK 4/2	SK 4/2
Sur-Gard	System I through V	SIA DCS 8	SIA20	Ademco Contact ID	SK 3/1	SK 3/1	SK 4/2	SK 4/2
Sur-Gard	System III*	SIA DCS 8	SIA20	Ademco Contact ID	SK 3/1	SK 3/1	SK 4/2	SK 4/2

*For FM use only

The FCA2015-U1 is also compatible with alarm communicators that utilize different communication technologies (IP and GSM technologies) to connect to compatible receivers using compatible protocols listed within this document.

COMPATIBLE ALARM COMMUNICATORS

Manufacturer	Model #	Comm Tech	UL Approved	ULC Approved	Dialer capture protocol	ULC Communication Type
Telguard (Telular)	TG-7FS	GSM	UL864 (10th Ed.)	Yes	support Contact ID (CID) SIA DCS	ACTIVE communication only
Bosch	B465	IP/GSM	UL864 (10th Ed.)	Yes	CID and SIA	Active communication only
Bosch	C900V2 (Discontinued)	IP	UL864 (9th Ed.)	No		Model discontinued
DSC	LE4010-CF	GSM	UL864 (10th Ed.)	Yes	CID or SIA	Active or Passive communication
DSC	TL300CF	IP	UL864 (10th Ed.)	Yes	CID	Active or Passive communication
DSC	3G3070-CF (Discontinued)	GSM	UL864 (9th Ed.)	Yes		Model discontinued
NAPCO Starlink	SLE-LTEVI-FIRE	IP/GSM	UL864 (10th Ed.)	No	CID	
NAPCO Starlink	SLE-LTEVI-CFB	IP/GSM	UL864 (10th Ed.)	No	CID	
NAPCO Starlink	SLE-LTEVI-CFBPS	IP/GSM	UL864 (10th Ed.)	No	CID	

NOTES:

- The DACT can be used with alarm communicators that also employ other transmission technologies for off-premises signaling for UL and ULC.
- When using these alarm communicators, the DACT shall be configured for Contact ID or SIA DCS. Please refer to the Compatible Alarm Communicators table.
- Refer to the Alarm Communicator Installation Instruction for compatible receivers.
- The use of a 3rd Party communicator may require Aux 24VDC from the FACP.

Use of 3rd party communicator for UL:

1. As sole communication path, maximum supervision window is 60 min.
2. As 2nd path for DACT, maximum supervision window is six hours.

Use of 3rd party communicator for ULC:

1. As sole Active Communication path, maximum supervision window is 180 seconds.
2. Work with DACT as 2nd Passive Communication path, maximum supervision window is 24 hours.

Refer to the installation instructions for the external communicator for specific power requirements and include with the system battery calculations to ensure adequate secondary power.

- Wiring between the DACT and the alarm communicator shall be within 20 feet, and in conduit for US, and within 18 meters in metallic conduit for Canada.
- All compatible Alarm Communicators shall be installed in accordance with their installation instructions.
- A means must be provided for detection of faults on the communicator by the fire alarm panel, as described in the installation instructions for the communicator. This is typically done by connecting a trouble-activated relay or PGM output on the communicator to an input switch module (i.e. HTRI).
- For ULC Passive Communication, the TL300CF and LE4010-CF communicators must be wired as shown in the following diagrams.

ULC Passive Configuration

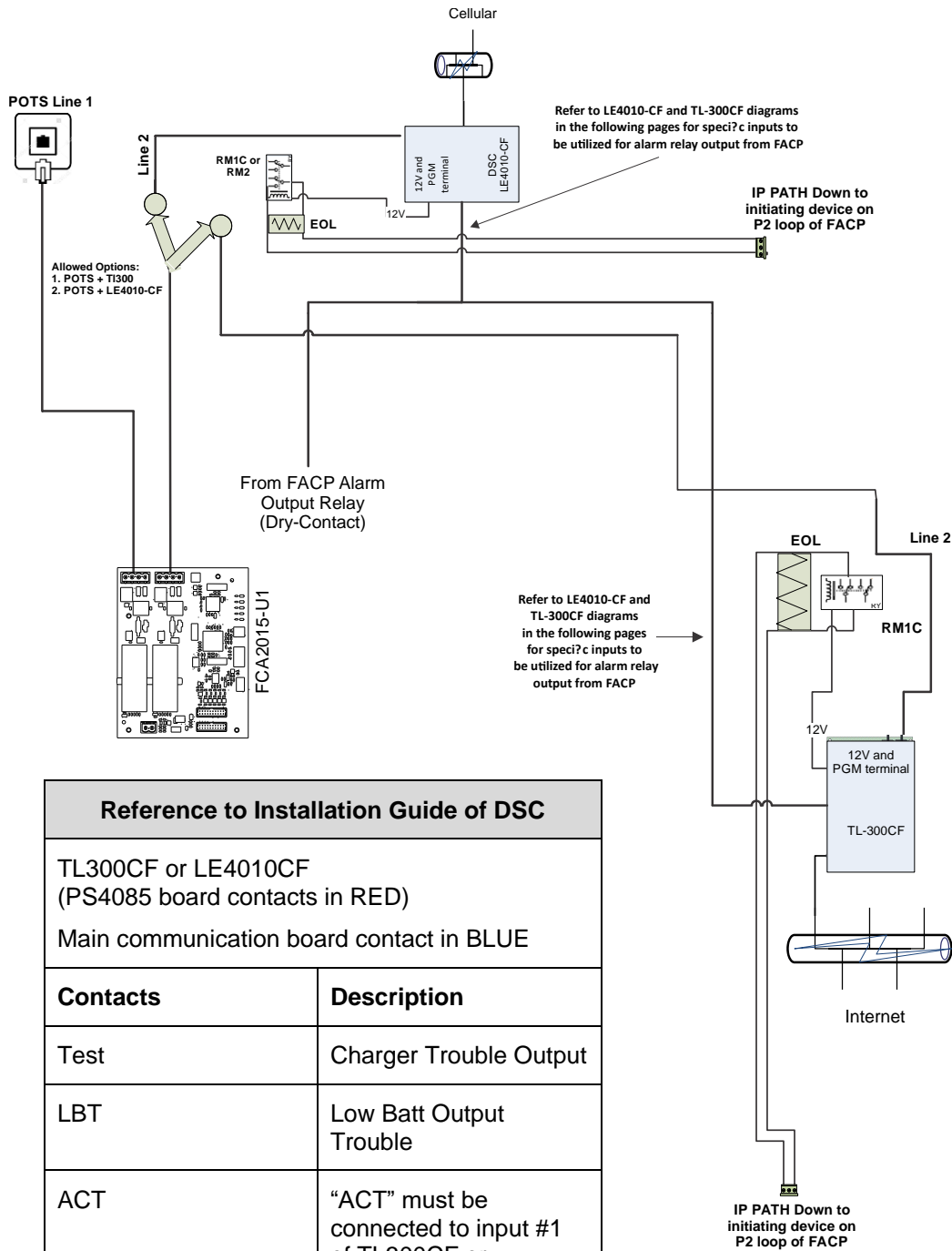

Reference to Installation Guide of DSC	
TL300CF or LE4010CF (PS4085 board contacts in RED) Main communication board contact in BLUE	
Contacts	Description
Test	Charger Trouble Output
LBT	Low Batt Output Trouble
ACT	“ACT” must be connected to input #1 of TL300CF or LE4010CF Note: AC trouble delay must be configured via CONNECT 24
Utilize PGM1 (TL300CF) or PGM4 (LE4010CF)	Communicator PATH DOWN Utilize PGM1 (TL300CF) or PGM4 (LE4010CF)

LE4010-CF Configuration

(Reference from DSC Installation Manual)

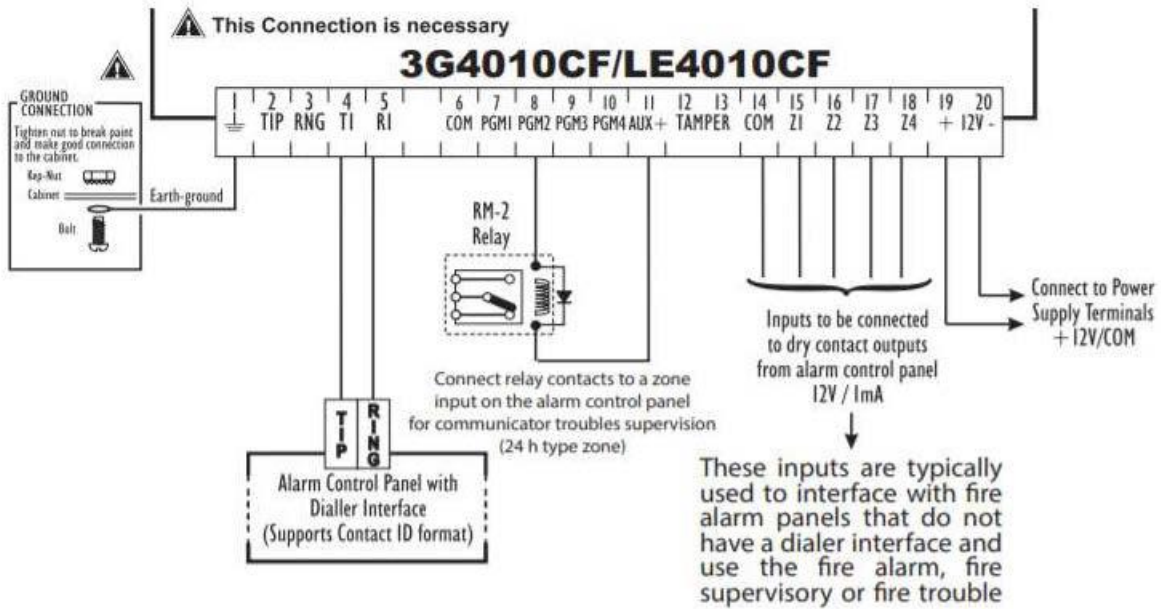

TL300-CF Configuration

(Reference from DSC Installation Manual)

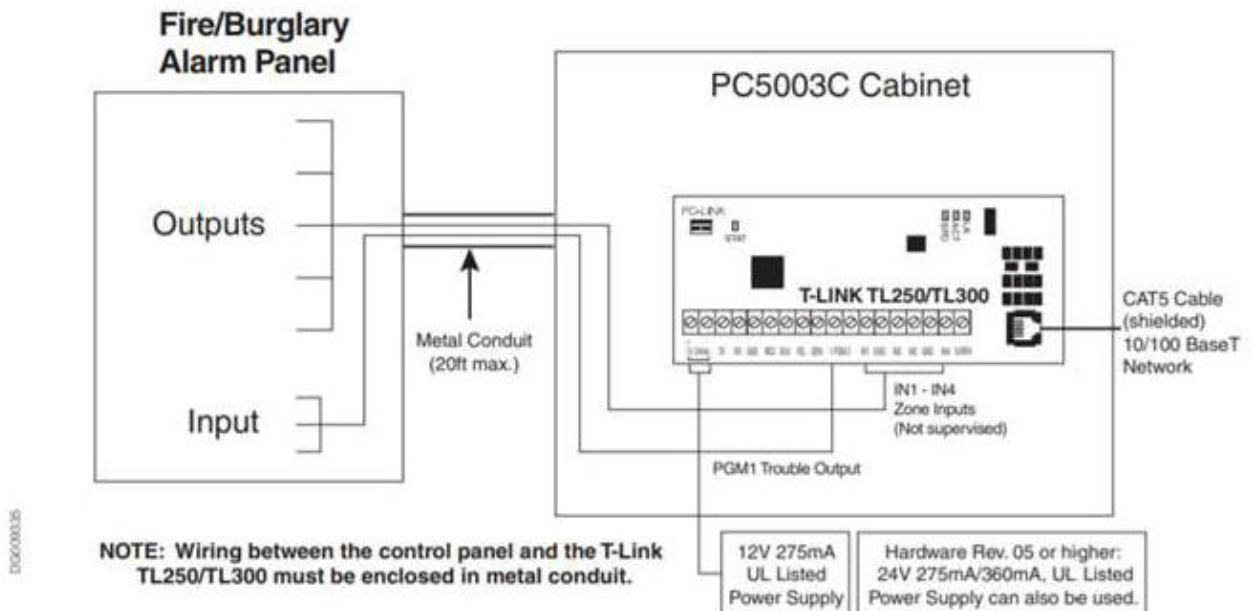

- Wire the panel's Tip and Ring terminals to the T1 and R1 terminals of TL300

LE4010-CF & TL300-CF Power Supply Wiring Configuration

(Reference from DSC Installation Manual)

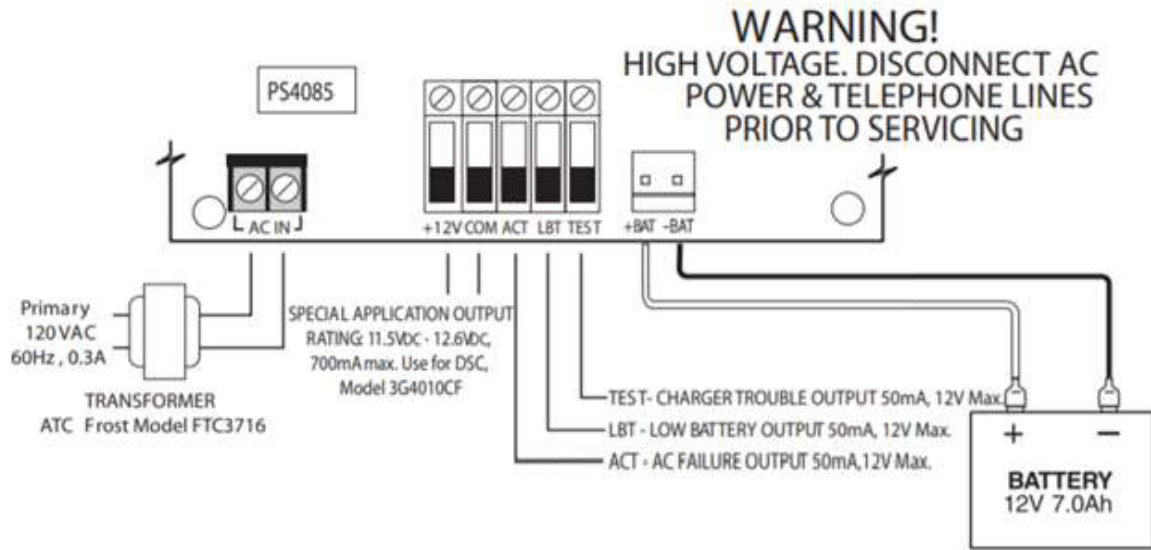

The ACT shall be connected to Input 1 of the transmitter and transmission delay is to be configured via CONNECT 24.

The LBT and TEST shall be connected to FACP's trouble inputs. The outputs are active low (switched to ground) and shall be connected via listed supervision relay (suggested model: DSC, RM-2 or RM1C).

FCA2015-U1 EVENT CODES

Event Type	SIA DCS (8 or 20)*⁵	Ademco Contact ID*⁵	3/1 1400 Hz or 2300HZ	4/2 1400 Hz or 2300HZ
Fire Alarm	FA pppp	1 110 0p ppp	0	01
Fire Alarm Restore (Through Reset)	FH pppp	3 110 0p ppp	2	21
Smoke Alarm	FA pppp	1 111 0p ppp	0	01
Smoke Alarm Restore	FH pppp	3 111 0p ppp	2	21
Heat Alarm	FA pppp	1 114 0p ppp	0	01
Heat Alarm Restore	FH pppp	3 114 0p ppp	2	21
Pull Station Alarm	FA pppp	1 115 0p ppp	0	01
Pull Station Alarm Restore	FH pppp	3 115 0p ppp	2	21
Waterflow Alarm	SA pppp	1 113 0p ppp	0	02
Waterflow Alarm Restore	SH pppp	3 113 0p ppp	2	22
Supervisory	SS pppp	1 200 0p ppp	6	66
Supervisory Restore	SR pppp	3 200 0p ppp	7	76
AC Trouble	AT	1 301 00 000	8	80
AC Trouble Restore	AR	3 301 00 000	7	70
Trouble	FT pppp	1 373 0p ppp	8	83
Trouble Restore	FJ pppp	3 373 0p ppp	7	73
System Battery Trouble	YT	1 302 00 000	8	87
System Battery Trouble Restore	YR	3 302 00 000	7	77
Phone Line 1 Trouble	LT 1	1 351 00 000	8	81
Phone Line 1 Trouble Restore	LR 1	3 351 00 000	7	71
Phone Line 2 Trouble	LT 2	1 352 00 000	8	82
Phone Line 2 Trouble Restore	LR 2	3 352 00 000	7	72
Data Lost	RT 0	1 354 00 000	8	88
Automatic Test (Normal)	RP	1 602 00 000	9	30
Automatic Test (Off Normal)	RY	1 608 00 000	9	39
Manual Test	RX 0	1 601 00 000	9	99
Test Activation	FX pppp	1 611 0p ppp	9	91
Gas Alarm	GA pppp	1 151 0p ppp	0	03
Gas Alarm Restore	GH pppp	3 151 0p ppp	2	23
Communications Fail	YC	1 350 00 000	8	84
System Reset	OR 0	1 305 00 000	7	79
Test Begin	FI pppp	1 604 0p ppp	9	90
Test End	FK pppp	3 604 0p ppp	9	92
Mass Notification Alarm ⁴	PA pppp	1 120 0p ppp	1	11
Mass Notification Alarm Restore ⁴	PH pppp	3 120 0p ppp	3	31
Mass Notification Trouble ⁴	PT pppp	1 375 0p ppp	8	83
Mass Notification Trouble Restore ⁴	PJ pppp	3 375 0p ppp	7	73
MNS1 ¹	XB pppp	1 789 0p ppp	1	11
MNS1 Restore ¹	XC pppp	3 789 0p ppp	3	31
MNS2 ¹	XN pppp	1 788 0p ppp	6	66
MNS2 Restore ¹	XP pppp	3 788 0p ppp	7	76
MNS Trouble ¹	XU pppp	1 787 0p ppp	8	83
MNS Trouble Restore ¹	XV pppp	3 787 0p ppp	7	73
Security ³	TA pppp	1 137 0p ppp	6	68
Security Restore ³	TH pppp	3 137 0p ppp	7	78
Emergency ^{2, 4}	EB pppp	1 785 0p ppp	6	65
Emergency Restore ^{2, 4}	EC pppp	3 785 0p ppp	7	75
Building ²	ZA pppp	1 152 0p ppp	6	65
Building Event Restore ²	ZH pppp	3 152 0p ppp	7	75
"Other" ²	XY pppp	1 786 0p ppp	4	40
"Other" Restore ²	XZ pppp	3 786 0p ppp	5	50

***pppp** is the dialer group or zone number

¹XLS/Desigo Fire Safety Modular/Cerberus PRO Modular only, if set to either “US/Other” or “Canada”

²XLS/Desigo Fire Safety Modular/Cerberus PRO Modular only, if set to “Canada”

³XLS/Desigo Fire Safety Modular/Cerberus PRO Modular only, if set to “US/Other”

⁴Desigo FC2025/FC2050, FV2025/FV2050, Cerberus PRO FC922/FC924, FV922/FV924 only

⁵Only SIA DCS and Ademco Contact ID can be used for UL 864 10th Edition off-premises signaling

ELECTRICAL RATINGS	
Standby 24DC Module Current	33.5mA
Active 24VDC Module Current	43.5mA

INDICATORS		
LED	Function	Description
H100	“OK LED”	Hardware is functionally good
H200	“L1 FLT”	Red LED on Solid – Line Connection error while dialing out, Line 1, Red LED Flashing DACT Dialing out on Line 1
H201	“L2 FLT”	Red LED on Solid – Line Connection error while dialing out, Line 2, Red LED Flashing DACT Dialing out on Line 2
H202	“RX”	DACT receiving information in
H203	“TX”	DACT Transmitting information out
H204	“UP RUN”	Green Flashing DACT has heartbeat

FCC Statement

	WARNING!
	Installation and usage of equipment not in accordance with instructions manual may result in: Radiation of radio frequency energy Interference to radio communications <ul style="list-style-type: none">• Install and use equipment in accordance with instructions manual• Read the following information

This equipment generates, uses, and can radiate radio frequency energy and if not installed and used in accordance with the instructions manual, may cause interference to radio communications.

It has been tested and found to comply with the limits for a Class A computing device pursuant to Part 15 of FCC Rules, which are designed to provide reasonable protection against such interference when operated in a commercial environment.

Operation of this equipment in a residential area is likely to cause interference in which case the user at his own expense will be required to take whatever measures may be required to correct the interference.

*As per ULC S559, the FCA2015-U1 is classified as an Active Communication System.