

The Advanced® Osmometer

Model 3250

User's Guide



**ADVANCED
INSTRUMENTS, INC.**

Two Technology Way / 781-320-9000
Norwood, Massachusetts 02062, USA
800-225-4034 Fax: 781-320-8181
www.aicompanies.com

3255 Rev17 031813

Copyright

This user's guide is copyrighted by Advanced Instruments, Inc. with all rights reserved. Under copyright laws, this guide may not be reproduced in any form, in whole or part, without the prior written consent of Advanced Instruments.

© 2003 Advanced Instruments, Inc.

Advanced Instruments has reviewed this guide thoroughly. All material contained within is believed reliable, but the accuracy and completeness are not guaranteed or warranted, and are not intended to be representations or warranties concerning the product described.

Microsoft® and Windows® are registered trademarks of Microsoft Corporation in the United States and other countries. Intel® is a registered trademark of Intel Corporation in the United States and other countries. All other trademarks are the property of Advanced Instruments.

Hot-Line® Service

If you have any questions or problems regarding the proper operation of your instrument, please contact our Hot-Line Service department by calling one of the following numbers.

- 800-225-4034 (toll-free within the USA and Canada; after normal business hours, dial extension 2191)
- +US 781-320-9000 (elsewhere)
- 781-320-0811 (fax)

Table of Contents

Safe Use	vii
Symbol Conventions	vii
General Cautions	viii
FCC Requirements	ix
Supplies, Parts & Accessories	xi
Calibrators & Standards	xiii
Foreword: Theory and Technique	xv
Chapter 1 — Installation & Setup	1
Step 1 — Find a location for the instrument	1
Step 2 — Obtain additional items	1
Step 3 — Unpack the instrument	2
Step 4 — Install the heat transfer fluid	2
Step 5 — Load printer paper	5
Step 6 — Power up the instrument	5
Step 7 — Prime the heat transfer fluid pump	7
Step 8 — Run a diagnostic test	8
Step 9 — Set date and time	9
Step 10 — Set language preference	9
Step 11 — Check initial factory calibration	9
Step 12 — Proceed to Chapter 2	10
<i>Figure 1: Model 3250 Osmometer and Accessories</i>	3
<i>Figure 2: Load Printer Paper</i>	6
<i>Figure 3: Prime the Heat Transfer Fluid Pump</i>	8
<i>Table 1: Model 3250 Osmometer Packing List</i>	3

Chapter 2 — Instrument Operation	11
Hazardous material cautions	11
Function of major components	12
Sample preparation	17
Sample handling	17
Verifying calibration daily	18
Sample test procedure	18
Repeatability tips	19
Sample test errors	24
Changing operating settings	24
Using the RS-232 port	32
<i>Figure 4: Model 3250 Components and Controls</i>	12
<i>Figure 5: Keypad Layout and Functions</i>	14
<i>Figure 6: Back Panel</i>	15
<i>Table 2: Barcode Port Connections</i>	17
<i>Table 3: Setup Menu Items</i>	23
Chapter 3 — Standards & Quality Control	33
Repeatability and accuracy	33
Standards and controls	33
Maintenance of standards	34
Quality control implementation	34
Chapter 4 — Calibration	37
Calibration procedure	37
Calibration notes	39
Chapter 5 — Troubleshooting & Service	41
Service & maintenance cautions	41
Obtaining service	42
Routine maintenance	44
Shutdown and storage	45
Troubleshooting checks	45
Internal diagnostic tests	46
Fuse replacement	53
Sample probe checks and replacement	54

Mandrel, probe and stir/freeze wire alignment	58
Stir/freeze amplitude adjustment	61
<i>Figure 7: Fuse Replacement</i>	53
<i>Figure 8: Operating Head</i>	54
<i>Figure 9: Probe and Stir/Freeze Wire Alignment</i>	58
<i>Figure 10: Mandrel, Probe and Stir/Freeze Wire Adjustment</i>	59

Appendices

Appendix A — Troubleshooting Table	65
Appendix B — Product Specifications	73
Appendix C — Regulatory Notices	75
Appendix D — Warranty & Warranty Duties	79
Appendix E — Supplemental RS-232 Information	83
Appendix F — Symbol Definitions	87
Appendix G — Product Disposal and Recycling	91
Appendix H — Service Log	93

Index	95
--------------	-----------

Notes:

Safe Use

To reduce the risk of bodily injury, electric shock, fire, and damage to your instrument, please read and observe the precautions in this User's Guide.

- If the product is used in a manner not in accordance with the equipment design, operating instructions or manufacturer's recommendations, the operation of the product may be impaired to the extent that a safety hazard is created.
- Do not attempt to perform electrical work if you are not fully qualified. This manual is not a substitute for electrical training.

Symbol Conventions



The exclamation point within an equilateral triangle is intended to alert the user to the presence of important operating and maintenance (servicing) instructions in the literature accompanying this product.



The lightning flash with arrowhead symbol within an equilateral triangle is intended to alert the user to the presence of uninsulated dangerous voltage within the product's enclosure that may be of sufficient magnitude to constitute risk of electric shock to persons.



The static symbol within an equilateral triangle is intended to alert the user to the presence of internal components that could be damaged by static electricity.



This static symbol is intended to alert the user to the presence of a specific component that could be damaged by static electricity.

 This symbol indicates the presence of alternating current (AC).

 This symbol indicates the presence of a fuse.

 This symbol indicates the presence of protective earth ground.

 This symbol indicates the power is ON.

 This symbol indicates the power is OFF.

NOTE Additional symbol definitions are available in Appendix F.

General Cautions

- This product should be operated only with the type of power source indicated on the product's electrical ratings label. Refer to the installation instructions included with the product.
- If the power cord provided is replaced for any reason or if an alternate cord is used, the cord must be approved for use in the local country. The power cord must be approved for the product's listed operating voltage and be rated at least 20% greater than the ampere ratings marked on the product's electrical ratings label. The cord end that connects to the product must have an IEC 60320 connector.
- Plug the product into an approved grounded electrical outlet.
- Do not disable the power cord's grounding pin.
- If an extension cord or power strip is used, make sure that the cord or strip is rated for the product, and that the total ampere ratings of all products plugged into the extension cord or strip do not exceed 80% of the cord's or strip's rating limit.

- Route power cords so that they will not be walked on, tripped on, or pinched by items placed upon or against them. Pay particular attention to the plug, electrical outlet, and the point where the cord exits the product.
- Do not pull on cords and cables. When unplugging cords or cables, grasp the corresponding connector.
- Do not install or use this product in any area subject to extreme short-term temperature variations, or locations that exceed the specified operating environment temperatures.
- Never use this product in a wet area.
- To avoid injury or fire hazard, do not operate this product in an explosive atmosphere.
- Do not install or use the product on an unstable, non-level work surface.
- Do not operate this product with the covers removed or unsecured.

FCC Requirements

- **WARNING:** Changes or modifications to this unit not expressly approved by Advanced Instruments could void the user's authority to operate the equipment.
- This equipment has been tested and found to comply with the limits for a Class B digital device, pursuant to Part 15 of the FCC Rules. These limits are designed to provide reasonable protection against harmful interference in a residential installation. This equipment generates, uses, and can radiate radio frequency energy and, if not installed and used in accordance with the instructions, may cause harmful interference to radio communications. However, there is no guarantee that interference will not occur in a particular installation. If this equipment does cause harmful interference to radio or television reception, which can be determined by turning the equipment

off and on, the user is encouraged to try to correct the interference by one or more of the following measures:

- Reorient or relocate the receiving antenna.
- Increase the separation between the equipment and receiver.
- Connect the equipment into an outlet on a circuit different from that to which the receiver is connected.
- Consult the dealer or an experienced radio TV technician for help.

Supplies, Parts & Accessories

To order parts and accessories, contact the Advanced Instruments Customer Service Department by using one of the following numbers.

- 800-225-4034 (toll-free within the USA and Canada)
- +US 781-320-9000 (elsewhere)
- 781-320-3669 (fax)

PART DESCRIPTION	PART NO.
2-Amp Time Delay (T) Fuse for 100-130V	70022
Clapper	3C2241R
Sample Tubes, Disposable 0.2 or 0.25 mL	3LA825
Heat Transfer Fluid	3DA811
Heat Transfer Fluid Filter	4D3710
Air Filters (package of 6)	3D2340
Printer Paper (5 rolls)	FLA835
Operator/Supervisor Keys	3D3185
Probe/Stir Wire Alignment Tool Kit	3LA700
Replacement Sample Probe with Mandrel and one 10-mL ampule of Probe Bin Setting Fluid (Stainless Steel)	3D3700
Mandrel	3LH500
Power Cord (specify voltage and country)	_____

PART DESCRIPTION	PART NO.
One-way Check Valve	4D3705
Sample Tube Rack	3LA846
RS-232 Cable, 3 meters	RS232-CABLE
Service Manual	3255SM
Stir/Freeze Coil	3D2404
Stir/Freeze Wire	3LH243
Advanced® User Information CD-ROM	90P01
Quick Instruction Card (set of 3)	3250-7
User's Guide	3255
Yoke	3LH230
Software Update CD-ROM	SFW006
Software Update Kit (CD-ROM and Cable)	SFW008

Calibrators & Standards

To order calibrators and standards, contact the Advanced Instruments Customer Service Department by using one of the following numbers.

- 800-225-4034 (toll-free within the USA and Canada)
- +US 781-320-9000 (elsewhere)
- 781-320-3669 (fax)

DESCRIPTION	PART NO.
Clinitrol™ 290 mOsm/kg Reference Solution (ten 5mL ampules)	3LA029
Five-Level Osmolality Linearity Set: 100, 500, 900, 1500 and 2000 mOsm (ten 5mL ampules, two of each value)	3LA028
Protinol® 3-Level Protein Control Kit (nine 3mL bottles, three of each level)	3MA028
Renol™ Urine Osmolality Controls (eight 3mL bottles, two levels)	3LA085
100 mOsm/kg Calibration Standard (110mL bottle)	3LA010
100 mOsm/kg Calibration Standard (ten 5mL ampules)	3LA011
500 mOsm/kg Calibration Standard (110mL bottle)	3LA050
500 mOsm/kg Calibration Standard (ten 5mL ampules)	3LA051
900 mOsm/kg Calibration Standard (110mL bottle)	3LA090
900 mOsm/kg Calibration Standard (ten 5mL ampules)	3LA091
1500 mOsm/kg Calibration Standard (110mL bottle)	3LA150
1500 mOsm/kg Calibration Standard (ten 5mL ampules)	3LA151
2000 mOsm/kg Calibration Standard (ten 5mL ampules)	3LA201
3000 mOsm/kg Calibration Standard (ten 5mL ampules)	3LA301

NOTE Advanced Instruments, Inc. cannot guarantee the stated instrument performance specifications and accuracy of test results unless Advanced Instruments brand consumables are used with the instrument. Use of consumables from manufacturers other than Advanced Instruments is not recommended and may adversely affect system calibration, performance, operation, and accuracy of test results. For information on obtaining these standards and controls, contact Advanced Instruments or an authorized representative.



Foreword

Intended Use

Advanced® Osmometers use the technique of freezing-point depression to measure osmolality. Osmolality is the total solute concentration of an aqueous solution. Osmometers measure the number of solute particles irrespective of molecular weight or ionic charge. This information is useful to the following disciplines:

- Clinical, emergency and sports medicine
- Medical research
- Biotechnology and pharmaceutical research and manufacturing
- Food and beverage manufacturing
- Environmental research and monitoring
- Academic research
- Industrial applications

When used by a trained operator in clinical applications, the osmometer provides results that assist in establishing the proper diagnoses and treatments for patients with disorders involving water and electrolyte imbalances. Osmometers will test virtually any biological fluid including, but not limited to, whole blood, plasma, urine, feces, sweat, and tissue homogenate. Operation of the instrument is deemed to be low-complexity under CLIA and FDA guidelines.

Principles of Freezing-Point Osmometry

When a solute is dissolved in a pure solvent, the following changes in the solution's properties occur:

- the freezing point is depressed,
- boiling point is raised,
- osmotic pressure is increased, and
- vapor pressure is lowered.

These are the so-called "colligative" or concentrative properties of the solution which, within reasonable limits, change in direct proportion to the solute concentration; in other words, the number of particles in solution.

Of the colligative properties, measurement of the freezing point allows the concentration of an aqueous solution to be easily determined with great precision.

The freezing point of pure H₂O is precisely +0.010°C. One mole of a non-dissociating solute such as glucose (where the solute does not dissociate into ionic species, but remains intact), when dissolved in 1 kilogram (kg) of water will depress the freezing point by 1.858°C. This change is known as the freezing point depression constant for water. The freezing point depression also depends upon the degree of dissociation of the solute. If the solute is ionic, the freezing point is depressed by 1.858°C for each ionic species. For example, if one mole of sodium chloride were to completely dissociate into two ionic species (Na⁺ and Cl⁻) in 1 kg of water, the freezing point would be depressed by 3.716°C. However, dissociation is never complete. Interference between solute molecules reduces dissociation by a factor called the osmotic coefficient.

In a simple solution such as glucose or sodium chloride in water, the freezing point can be measured and the unit concentration easily determined from an equation or a reference table. However, the equation is unique for each solute. In a more complex solution, all ionized and non-dissociated species contribute to the freezing-point depression and the concentration of each solute cannot be easily determined.

Each of the colligative properties has a similar problem, and though each of the colligative properties changes in direct proportion to the solute concentration, each requires a different mode & unit of measurement. Osmolality is a common unit of concentration measurement that can be used to relate all the colligative properties to each other, and to other concentration units. Because of its universality, most osmometry applications regularly use osmolality, expressed as "mOsm/kg H₂O", as the common unit of concentration rather than applying further conversion factors.

Instrumentation

Advanced[®] Osmometers are devices for the determination of the concentration of solutions by means of freezing-point measurement.

Advanced Osmometers utilize high-precision thermistors to sense the sample temperature, to control the degree of supercooling and freeze induction, and to measure the freezing point of the sample. They can routinely determine differences of ± 1 mOsm/kg H₂O.

Freezing-Point Thermodynamics

The quickest and most precise way to measure the freezing point of a solution is to supercool it several degrees below its freezing point. It is unstable in this state, and a mechanical agitation induces crystallization. The heat of fusion suddenly liberated causes the sample temperature to rise toward a plateau temperature, where a liquid/solid equilibrium occurs. The equilibrium temperature is, by definition, the freezing point of the solution. Managing the plateau temperature for precise measurement is the basis for several patents issued to Augustus Fiske.

The time over which liquid/solid equilibrium develops and is maintained, is a function of the speed with which the heat-of-fusion is liberated vs. the speed it is transferred away, or absorbed, by the surrounding environment. This ratio can be slowed and the equilibrium time stretched, to give a distinct plateau height measurable to 0.001°C.

Sensitive thermistor probes monitor the sample temperature and control the thermoelectric cooling element. Microprocessor control and automated operation minimize imprecision due to operator technique.

The following Standard Freezing Curve illustrates the temperature of a sample as it progresses through the freezing cycle and shows the action of the instrument at each stage of the cycle.

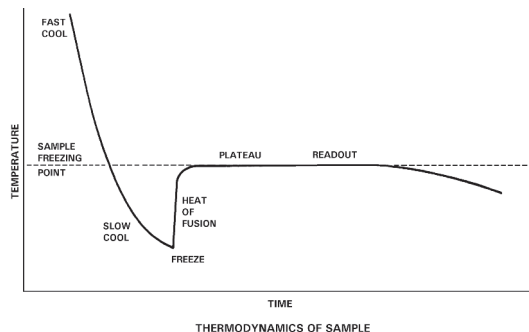

Standard Freezing Curve

Definitions

Solution: A homogeneous mixture of solute and solvent in which the solvent is usually the major component, and the solute is the minor component.

Concentration: The ratio of solute to a given amount of solvent (molal), or ratio of solute to solution (molar).

The amount of solute is usually expressed in terms of moles (i.e., gram molecular weights). One mole = 6.028×10^{23} molecules (Avogadro's number). One mole of glucose (180.2 g) and one mole of sodium chloride (58.4 g) each contain Avogadro's number of molecules.

Common units of concentration are:

- **Molality:** Moles of solute per kilogram of pure solvent.
- **Osmolality:** Osmols of solute particles per kilogram of pure solvent. As noted above, most ionic solutes do not completely dissociate. Osmolality is a unit of concentration that takes into account the dissociative effect. Osmolality is usually expressed in mOsm/kg H₂O. One milliosmol (mOsm) is 10^{-3} osmols. Osmolality is defined as:

$$\text{Osmolality} = \phi n C = \frac{\text{osmol}}{\text{kg H}_2\text{O}}$$

where:

ϕ = osmotic coefficient, which accounts for the degree of molecular dissociation.

n = number of particles into which a molecule can dissociate.

C = molal concentration of the solution.

- **Molarity:** Moles of solute per liter of solution.
- **Osmolarity:** Osmols of solute particles per liter of solution. Although molarity and osmolarity may be common units of measurement in other branches of chemistry, they are not used in osmometry because the ratio of solute to solution is not linear. Molality and osmolality are linear, independent of the effect of temperature and volume displaced by solute. A calculated conversion between units of molality and molarity is complex and generally unnecessary when the terms are properly understood.

Freezing Point/Melting Point: The temperature at which the liquid and solid phases of a substance will remain together in equilibrium.

Freezing-Point Depression: When a solute is added to a solvent, the freezing point of the solvent is lowered. In aqueous solutions, one mOsm of solute per kilogram of water depresses the freezing point by 1.858 millidegrees Celsius ($m^{\circ}C$).

Supercooling: The tendency of a substance to remain in the liquid state when cooled below its freezing point.

Crystallization Temperature: Aqueous solutions can be induced to freeze (i.e., crystallize) most reliably when supercooled. When supercooled, agitating the solution (freeze pulse) induces crystal formation. The crystallization temperature is the temperature at which crystallization is induced. During crystallization, the heat of fusion raises the temperature of the sample to an ice/water freezing-point plateau.

Heat of Fusion: The heat released when the mobile molecules of a liquid are frozen into rigid ice crystals.

Freezing-Point Plateau: The constant temperature maintained during the time that ice and liquid exist in isothermal equilibrium after crystallization occurs.

1 Installation & Setup



*In order to set up your instrument properly, it is important that you read and follow the steps in this section. Please follow these steps carefully and be sure to read **Chapter 2 — Instrument Operation** before attempting to run tests on your instrument.*

Step 1 — Find a location for the instrument

When choosing a location for your new osmometer, be sure to meet the following criteria.



- Adequate space. The dimensions of the instrument are 12.5 × 17.5 × 11.5 inches (32 × 44 × 29 cm). Be sure to keep your workplace free of debris and allow 6 inches (15 cm) of clear space on each side of the instrument for fan-driven air circulation.
- Electric outlet availability. Your instrument will need to operate within five feet of a properly grounded, three-prong electrical outlet capable of continuously supplying 2 amperes at 100-250V. If the instrument is not grounded properly, its operation may be impaired and a safety hazard may exist. Therefore, be sure to test the outlet and record the results before operating your instrument.

Step 2 — Obtain additional items

To operate your instrument, you will need to obtain the following items:

- Soft, no-lint, non-ionic paper tissues for wiping the sample probe.
- Clean, dry 0.2-mL or 0.25-mL pipette.

Step 3 — Unpack the instrument

To unpack your osmometer, take the following steps.

- a. Carefully unpack your osmometer, accessories and supplies and inspect them for shipping damage. Use the enclosed packing list to verify that all items have been received.
- b. Save your osmometer's shipping boxes and packaging material in case future transport of the instrument becomes necessary.
- c. If any item on the packing list appears to be missing from your shipment, please search carefully through and under all packing materials. If the item is not found, notify your receiving department immediately. Advanced Instruments can only be responsible for items reported missing within 10 days of a shipment's arrival.
- d. If you receive any damaged items, save the cartons and packing material those items came in for inspection by the insurer. The carrier, dealer, and Advanced Instruments must be notified within 24 hours in order for your warranty and insurance to apply. Have the transportation company inspect items, fill out a "Report of Concealed Damage," and file your claim. Then, notify Advanced Instruments immediately for repair or replacement.
- e. Fill out the warranty card enclosed. Mark the appropriate boxes if you wish to receive additional information. Mail or fax to 781-320-8181.

Step 4 — Install the heat transfer fluid

1. Pull forward the top of the heat transfer compartment door to release the magnetic latch, then pull the door all the way open (see Figure 5).
2. Locate the bagged plastic tubes protruding through the back wall of the compartment. Remove and discard the plastic bag from the ends of the tubes.



Figure 1: Model 3250 Osmometer and Accessories

<u>Quantity</u>	<u>Part No.</u>	<u>Description</u>
1	3250	The Advanced® Model 3250 Osmometer
1 pack	3LA011	100 mOsm/kg Calibration Standard
1 pack	3LA151	1500 mOsm/kg Calibration Standard
1 pack	3LA201	2000 mOsm/kg Calibration Standard
1 pack	3LA301	3000 mOsm/kg Calibration Standard
1 pack	3LA029	Clinitrol™ 290 mOsm/kg Reference Solution
1 pack	3LA028	Osmolality Linearity Set, 5 levels
2 bottles	3DA811	Heat Transfer Fluid
1	3D3185	Operator/Supervisor Keys (set of 2)
1	FL0408	Paper Roll Holder
1	_____	Power Cord (as specified)
2 rolls	_____	Printer Paper (reorder package of 5 rolls as FLA835)
1	3LA700	Probe/Stir Alignment Tool Kit
1	3LA846	Sample Tube Rack
1 pack	_____	Sample Tubes Pack (reorder pkg of 500 as 3LA825)
1	90P01	Advanced® User Information CD-ROM
1	3250-7	Quick Instruction Card (<i>English/French</i>)
1	3250-70	Quick Instruction Card (<i>German/Spanish</i>)
1	3250-71	Quick Instruction Card (<i>Italian/Swedish</i>)
1	3255	User's Guide
1	3255-6	Warranty Card
1	3D3P021	Customer Satisfaction Card

Table 1: Model 3250 Osmometer Packing List

3. A heat transfer fluid filter should already be mounted on the smaller of the two plastic tubes. If replacement is necessary, force the tubular end of the heat transfer fluid filter at least ¼" or 6 mm into the free end of the smaller of the two tubes.

CAUTION The heat transfer liquid contains hazardous chemicals. Consult the material safety data sheet (MSDS) and use appropriate personal protective equipment.



4. Open a bottle of heat transfer fluid.
5. Insert the plastic tube with the heat transfer fluid filter into the bottle of heat transfer fluid so as to locate the filter at the bottom of the bottle.
6. Insert the free end of the larger of the two plastic tubes into the neck of the heat transfer fluid container to return the heat transfer fluid to the container for recirculation.
7. Stand the container of heat transfer fluid in the plastic tray in the heat transfer fluid compartment, making sure the filter remains low in the heat transfer fluid. Press the bottle into the retainer clip.
8. Close the compartment door.

NOTE When the heat transfer fluid level reaches the REPLACE line on the bottle label, discard remaining solution and replace with a new bottle of heat transfer fluid (Part No. 3DA811). Continued use when fluid is below this level will change the thermodynamics of the test.

NOTE It is not recommended to top off the existing bottle of heat transfer fluid, due to moisture and growth that exist. Always discard the old bottle and fluid and replace with a new bottle.

NOTE Should it become necessary to move the instrument to another location after the heat transfer fluid has been installed, take appropriate precautions to prevent fluid spillage.



Step 5 — Load printer paper (Figure 2)

A roll of thermal printer paper and a roller are supplied with the instrument. These must be installed in the printer as follows:

1. Fully depress the printer cover release button located immediately in front of the printer cover, then lift up on the printer cover to open. Release the printer cover release button.
2. Unroll about 6" (15 cm) of paper from the paper roll.
3. Insert the roller into the paper roll.
4. Place the paper roll and roller into the V-shaped roller supports, as shown in the upper-right photo of Figure 2. Make sure the paper roll is oriented as shown, *feeding from the bottom of the roll*. When both ends of the roller are in proper position, the paper roll should be level. If the paper roll is not level, carefully reseal the roller between the roller guides.
5. Hold the paper down onto the surface of the osmometer and center the paper on the printer tear bar. When the paper is centered, gently close the printer cover. Press on the top of the printer cover to make sure it is firmly latched with the printer mechanism.
6. The printer paper is loaded and ready for operation.

CAUTION Do not attempt to pull the paper through the printer, as this may damage the mechanism. Either release the printer cover by fully depressing the printer cover release button and lifting up on the cover, or use the **Feed** button on the keypad to advance the paper.



Step 6 — Power up the instrument

Power up the 3250 in the following manner:

1. Connect the power cord to the 3250 and the power outlet.
2. If the 3250 has been installed as instructed in the previous steps, turn

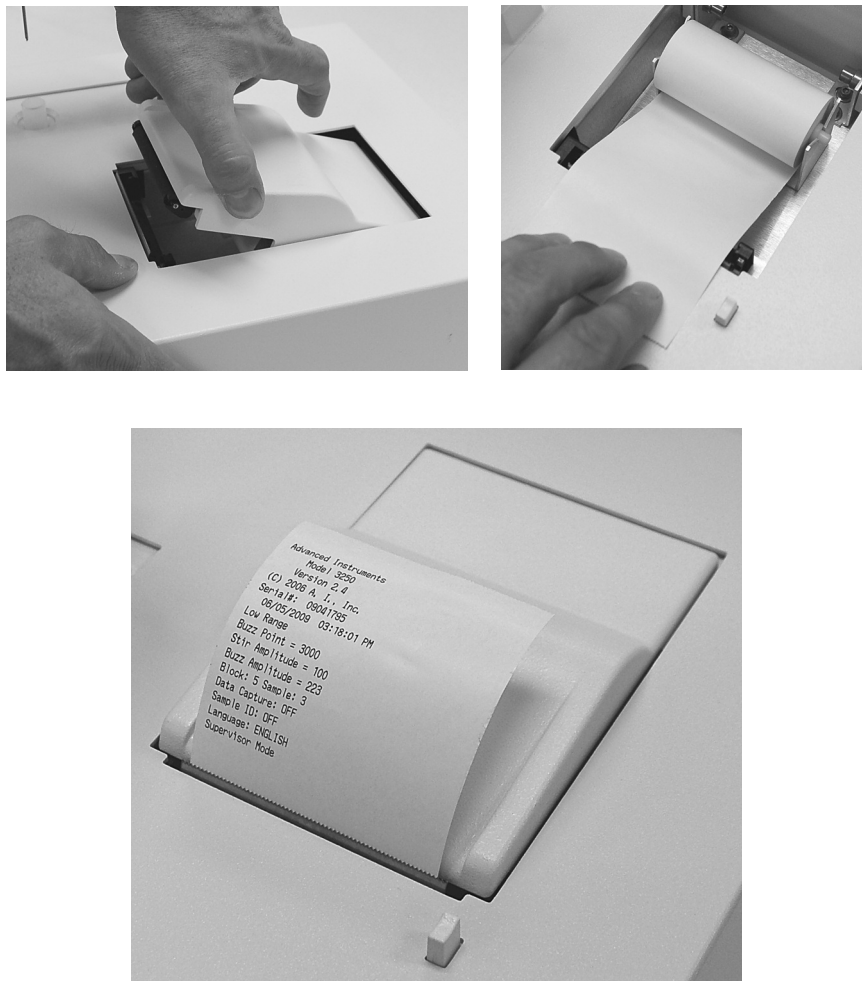

Figure 2: Load Printer Paper

the **POWER** switch on. The display will begin to scroll, and the printer will begin printing.

3. Record the displayed software revision and the block and sample probe bin numbers reported by your instrument in the service log at the end of this user's guide. When all of the instrument data has been displayed, the operating head will rise and "**Press START to Continue**" will begin to scroll across the display.

CAUTION If a power interruption occurs, turn the instrument off at once. Leave it turned off for at least 5 seconds after power has been restored (even if power restoration is immediate).



Step 7 — Prime the heat transfer fluid pump

The first time the instrument is being started, you will need to prime your heat transfer fluid pump using the **TEST** menu as follows:

1. Insert sample tube in well and press the **TEST** key. The display will change to "**Select Test Item**".
2. Press the < key to step the display backward to "**Head Up/Down Test**".
3. Press the **START** key. The display will change to "[**START**] Test [**STOP**]".
4. Press the **START** key.
5. Open the heat transfer fluid door to access the small primer pump (Figure 3). Squeeze the primer pump while the operating head is cycling, making sure to squeeze at the same time that the operating head reaches the bottom of its cycle. Observe the fluid return line from the cooling well back to the bottle. Once fluid begins to appear, continue priming for five more cycles to remove any trapped air. Stop using the primer pump and watch the return line to make sure that a small amount of fluid continues to flow through the return line with each head up/down cycle. Then press the **STOP** key to raise the operating head and exit to the test menu.

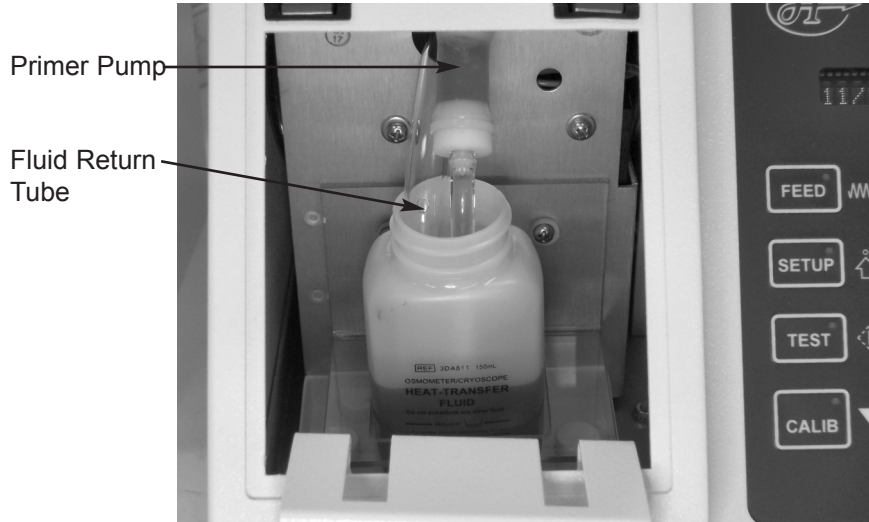

Figure 3: Prime the Heat Transfer Fluid Pump

6. Press the **STOP** key a second time to exit from the test menu to “Press **START** to Continue”.

Step 8 — Run a diagnostic test

With a sample tube containing fluid such as a calibration standard or deionized water in the freezing chamber, press the **START** key. The microprocessor will respond with the display, “**Running Diagnostics**”, while it lowers the operating head, cools the freezing chamber and completes a series of internal diagnostic checks. If the diagnostic checks are not successfully completed or the freezing chamber does not cool properly, a diagnostic message will be presented.

NOTE Any error reported prior to or during diagnostics will require the operator to press **STOP** before any of the keyboard commands can be used.



If the instrument has just been turned on, it takes a few minutes to cool the freezing chamber. If the heat transfer fluid pump has not been primed as described in step 7, the time will be longer.

When the freezing chamber has been cooled and the internal diagnostic checks have been completed, the operating head rises, “**Osmometer Ready**” is displayed, and an audible tone is sounded.

Step 9 — Set date and time

If you wish, you may now change your date and time settings by using the instructions found in Chapter 2 of this user’s guide.

Step 10 — Set language preference

The 3250 can be operated in multiple languages. Your instrument will initially be set for English. If you would prefer to operate the instrument on one of the other languages, you should change the language setting as described in Chapter 2.

Step 11 — Check initial factory calibration

Your instrument has been carefully calibrated by the manufacturer, but to verify that this calibration is accurate within your operating environment, run tests using low and/or high range calibration standards before testing samples. The number and type of tests that you run should be determined by your own laboratory’s standard protocol. Use the operating technique described in Chapter 2 when running these materials.

If you determine that the initial calibration is incorrect, recalibrate as described in Chapter 4.

NOTE If the 3250 has just been moved from a different location, it should be allowed to warm up for 20 to 30 minutes before running calibration verification tests.



Step 12 — Proceed to Chapter 2

If you have followed the steps outlined in this chapter, your instrument is ready for use. To learn how to operate your instrument, read the next chapter, "Instrument Operation". We strongly recommend that you read the entire second chapter before attempting to operate your osmometer.

2 Instrument Operation



*In order to run your instrument properly, it is important that you read and adhere to the instructions in this section. For information on calibration, see **Chapter 4 — Calibration**.*

Hazardous material cautions



- **WARNING:** Handle all biohazardous materials according to established good laboratory practices and follow your institution's exposure control plan. Persons handling human blood and body fluid samples must be trained in blood-borne hazards and observe universal precautions. Universal precautions is an approach to infection control, where all human blood and body fluids are treated as if known to be infectious. Use personal protective equipment such as gloves, gowns, etc., to prevent exposure. Store biohazardous materials in regulated waste containers and dispose of these materials in a safe and acceptable manner that is in compliance with all country, state and local requirements.

CAUTION The heat transfer fluid contains hazardous chemicals.



Consult the material safety data sheet (MSDS) and use appropriate personal protective equipment.

- Heat transfer fluid can become contaminated with sample material which may be considered a biohazard. Use appropriate cautions during removal and disposal of sample tubes after testing to prevent heat transfer fluid remaining on the tube exterior from contacting personnel or the instrument surface.
- If a biohazardous material is spilled on or inside the equipment, decontaminate the equipment using a 1% bleach solution, or as

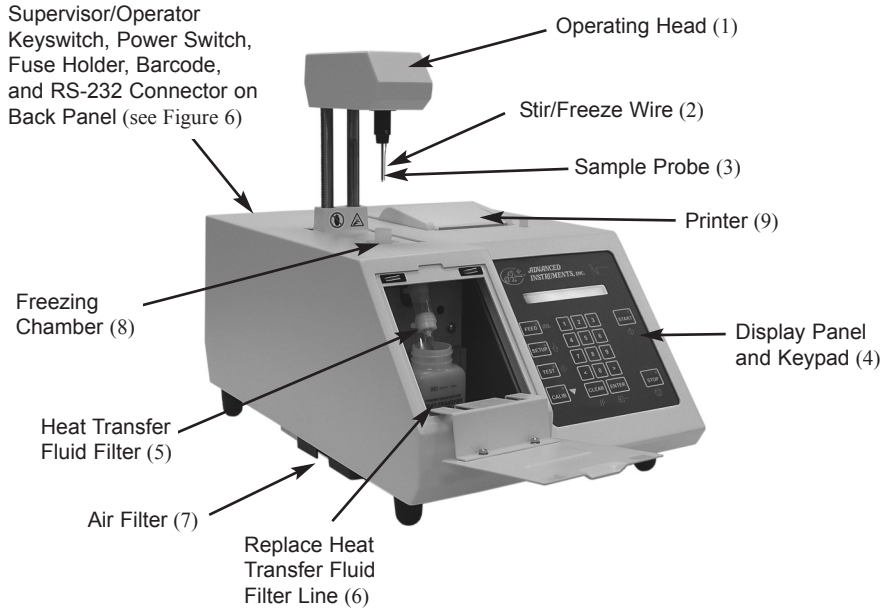

Figure 4: Model 3250 Components and Controls

outlined by those policies and procedures established within your institution.

- To avoid injury or fire hazard, do not operate this product in an explosive atmosphere.

Function of major components

Operation of the instrument will be quicker and easier if you become familiar with the locations and functions of the components, systems and controls described below before proceeding further.

Operating head (Figure 4, Item 1)

The operating head contains a stir/freeze wire with electrical means to vibrate it; an ultra-stable, ultra-precise thermistor sample probe; and devices to automatically locate the probe and sample in the freezing chamber.

Freezing chamber (Figure 4, Item 8)

Sample cooling is performed by a thermoelectric cold stage. The chamber contains a small amount of heat transfer fluid for optimum cooling capacity.

Measurement and control circuits (inside)

The microprocessor-controlled circuits automatically measure and control the dynamic temperature of the sample freezing chamber. Process calibration data and sample temperature information. They also present calibrated test results on the digital display.

Electronic circuits (inside)

The main circuitry is contained on two printed circuit boards in a motherboard/daughter board configuration. More in depth technical details are available in the unit service manual sold separately.

Processor Board: The processor board is the smaller of the two printed circuit boards and contains the Intel 80C186EB central processor, two flash EPROM's, RAM, Realtime clock, watchdog circuit, and glue logic.

Application Board: The application board contains the circuits for controlling and interfacing with the other subsystems such as the keypad, display, head motor, cooling assembly, RS-232, printer and barcode ports, etc. The application board also contains two 20-bit A/D converters for reading the sample and block probe thermistors.

Display panel (Figure 4, Item 4)

The display panel displays:

- Test status and results.
- Status messages when the instrument is turned on or when functions are selected.
- Pertinent error messages when fault conditions occur. (Messages longer than 20 characters scroll across display.)



FEED	Advances printer paper
SETUP	Activates the setup menu
TEST	Activates diagnostic test menu
CALIB	Initiates calibration procedure
1 through 0	Allows numeric input, as required
< and >	Steps through menu items
CLEAR	Clears some data in setup mode and when using sample identification
ENTER	Confirms sample identification and/or setup menu items
START	Starts tests and setup procedures
STOP	Cancels the procedure in process.

(Refer to Appendix F for symbol definitions.)

Figure 5: Keypad Layout and Functions

Keypad (Figure 4, Item 4)

The keypad allows operator input to the microprocessor. For the layout and functions of the keypad switches, please see Figure 6.

Printer (Figure 4, Item 9)

The printer records on paper the displayed test results, sample identification, and other necessary information.

Supervisor/Operator keyswitch (Figure 6)

The **Operator** position of the **Supervisor/Operator** keyswitch provides a means of locking out the setup and calibration functions of the instrument to help prevent unauthorized changes.

The **Operator** keyswitch position allows access to the sample and test function only; the **Supervisor** keyswitch position allows access to the setup, test and calibration functions, as well as the sample and test functions.

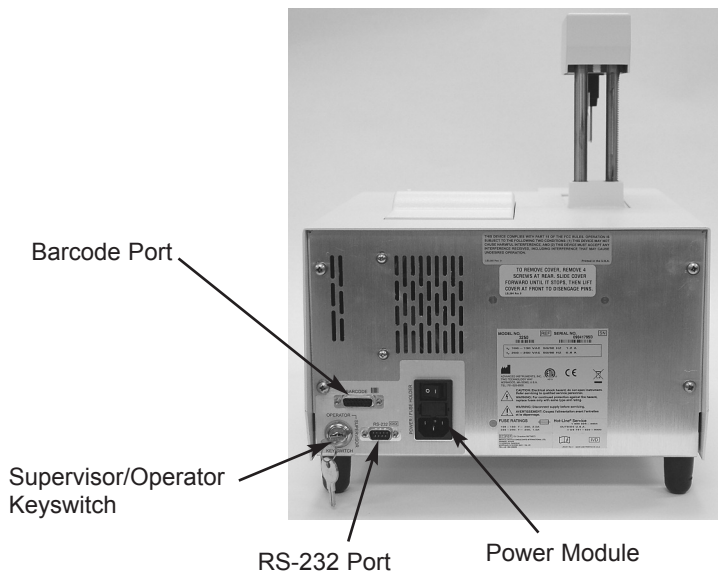

Figure 6: Back Panel

If the **SETUP** or **CALIB** key is pressed while the **Supervisor/Operator** keyswitch is in the **Operator** position, a “**Supervisor Key Needed; Press STOP to Continue**” message is continually scrolled across the display until **STOP** is pressed. When **STOP** is pressed, the message will change back to “**Ready**”, re-enabling the sample test function.

Power module (Figure 6)

The power module on the rear of the instrument contains the following components.

- *Power switch*
The rocker-style power switch controls the power to the instrument. The power switch may be left on continuously; the 3250 enters standby mode automatically if idle for more than 5 minutes.
- *Power cord connector*
The power cord connector accommodates a power cord suitable for the power available.
- *Fuse holder*
The fuse holder contains the instrument's necessary fuses. For instructions on replacing fuses, see Chapter 5.

RS-232 port (Figure 6)

The RS-232 port allows you to output your instrument's data/messages to an external device, such as a computer. For more detailed information dealing with the RS-232 port, please read the section titled “Using the 3250's RS-232 port”, which is found later in this chapter.

Barcode port (Figure 6)

A D-type, 15-pin barcode port is provided in the back of the 3250 for connecting and providing power to such a device. For proper operation, the barcode port requires a 1200 bps, RS232-level signal providing asynchronous serial data containing 1 start bit, 8 data bits, 1 stop bit and no parity.

Signal	Pin	Direction
+5V DC	1	to reader
receive data	10	from reader
gnd/earth	9	common

Table 2: Barcode Port Connections

A suitable barcode scanner is available from Advanced Instruments. To interface with the 3250, the barcode scanner must be programmed as follows, referring to the scanner users guide.

- 1200 bps
- CR suffix
- disable beep after good decode
- triggerless trigger mode (optional)

Sample preparation

No special sample preparation is required. Body fluids such as serum or plasma may be used directly.

NOTE Additives such as anticoagulants from collection tubes may contribute significantly to the measured osmolality.

Particulate matter and certain bacteria can also cause premature crystallization; in blood, it is normally eliminated by centrifugation. Particulate matter in urine may be removed by centrifugation or filtration through an inert filter.

Sample handling

Different sample tube sizes and styles should not be intermixed because each may require a different instrument adjustment and/or calibration. Sample tubes should be as uniform as possible in composition, shape and size. For optimum results, you should always use 3LA825 sample tubes.

Glass tubes generally are not as uniform in shape and size as plastic tubes, nor do they thermally isolate test samples as well. The 3250 operating parameters are optimized for Advanced Instruments plastic sample tubes (Part No. 3LA825); glass sample tubes may not provide the same repeatability. If you need further information concerning sample tube requirements, please contact Advanced Instruments as recommended in Chapter 5.

Samples should always be pipetted or measured. 0.25-mL or 0.2-mL samples may be used in Advanced Instruments sample tubes. To achieve the specified performance, we recommend that you use 0.25-mL samples; 0.2-mL samples require somewhat more critical probe and stir/freeze wire adjustments for similar precision in results. The 3250 should be calibrated with the same sample size used for testing.

Verifying calibration daily

Like most measuring instruments, osmometers need calibration against standards. Your 3250 was calibrated at the factory. The probe and calibration parameters are stored in parameter RAM which is powered by an internal battery when the instrument power is off or disconnected. Thus, when “**Osmometer Ready**” is displayed, your 3250 osmometer is calibrated and ready to run. However, the calibration should always be verified during operation to be sure that none of the parameters affecting calibration have changed. (If recalibration is required, see Chapter 4).

NOTE To verify the precision of your instrument, test products with known values within your reportable range (i.e., Clinitrol™ 290 mOsm/kg, Protinol® Protein-based Controls, Renol™ Urine Osmolality Controls).

Following is the recommended procedure for instrument operation:

Sample test procedure

1. Remove the sample tube from the freezing chamber (see Figure 4, Item 8).

Repeatability Tips

1. Sample tube cleanliness is extremely important for repeatability. Glass tubes should be washed in hot water containing a nonionic detergent, rinsed in distilled water, and thoroughly dried before each use.
2. Always treat all samples uniformly before the test. Treat standards and reference solutions the same as the unknowns. Do not intermix different tube styles.
3. To avoid contamination and evaporation, cover all samples not immediately being tested.
4. Use the same sample size consistently (i.e., during calibration, testing, etc.).
5. For repeat runs, use another sample from the same source or thaw the original sample before repeating. If you must rerun the same sample or use it for another procedure, remove it from the freezing chamber as soon as possible and keep it covered between tests.
6. Always use the same operating procedure as proper, consistent procedure is the key to repeatable results.
7. The first reading in any given period of operation may be slightly off because of temperature conditioning or residual contamination of the probe. Subsequent readings on aliquots of the same sample should group within the specifications as in Appendix B, if you practice good operating techniques.
8. If an occasional sample produces irregular results, discard obviously discrepant readings as long as the instrument has been producing accurate readings repeatedly. Repeat the reading in question.
9. Do not reuse plastic sample tubes or cleaning materials. Discard after each use.

2. Gently wipe the probe, stir/freeze wire, mandrel and the top of the freezing chamber (in that order) with a soft, lint-free, non-ionic paper tissue dampened with distilled water to remove anything that might contaminate the sample to be tested. Be careful not to bend the probe or stir/freeze wire.
3. Select a reference solution or NaCl standard with a freezing point close to that expected for your unknown (Advanced® Clinitrol™ 290 Reference Solution is recommended for serum). Swirl and carefully open an ampule of the reference solution (or NaCl standard) selected.

If the expected freezing point is in the 1500-4000 mOsm range, the high range should be selected. If the freezing point is *not* within the range selected, an error message will be displayed, requesting the range to be changed (see Setup Menu, later in this chapter).

4. Select a clean sample tube (see page 19, Repeatability Tips).
5. Pipette or measure a sample of the selected reference solution or NaCl standard into the clean sample tube and place the tube in the freezing chamber.
6. Press the **START** key.

I.D. #: If "**I.D. #**" has been enabled via the setup menu (see page 24), the instrument operator will be prompted for a sample or user identification number of up to 13 digits at this time from either the keypad or optional barcode scanner.

At the "**I.D. #**" prompt, the present setting may be retained by pressing **ENTER**.

The present setting may be erased entirely by pressing **CLEAR** or erased one digit at a time from the right by repeatedly pressing <.

A new number may be entered one digit at a time from the left via the numeric keypad, unless the number was input from a barcode scan in which case pressing < will erase the whole number.

Press **ENTER** to store the new setting and continue the test. “**Press START to Continue**” will begin to scroll across the display.

Press **START** (Pressing **STOP** would cancel the test).

The rest of the test is completely automatic. The operating head will lower the sample probe into the sample tube in the freezing chamber. The fan will come up to full speed and the freezing chamber will cool.

The sample temperature will follow the freezing curve shown in the Foreword, and will be displayed as soon as it falls below 0°C.

The 3250 will freeze the sample at a fixed crystallization point, follow the plateau development, determine the osmolality, and lock the result on the display.

NOTE If the **STOP** key is pressed while a test is in progress, the test will be discontinued and the 3250 will reset itself for the next test.

NOTE Sample ID# information will be printed on the printout and presented via the RS-232 port at the end of the test.

7. When the display reads “**Osmolality XXX mOsm**”, the operating head will automatically return to the start position, and the printer will print out the results.

NOTE If the wrong osmolality range has been selected, an error message will replace the osmolality report. Use the select range procedure to select the required range; then test another aliquot.

NOTE Results are displayed with the (-) negative temperature sign removed, per industry practice. However, if testing a sample with a near 0 mOsm value, it may be possible for a positive temperature value to be displayed with the negative sign preceding the mOsm value.

8. Remove the sample tube from the cooling well.

CAUTION The heat transfer fluid contains hazardous chemicals. Consult the material safety data sheet (MSDS) and use appropriate personal protective equipment.



CAUTION Heat transfer fluid can become contaminated with sample material which may be considered a biohazard. Use appropriate cautions during removal and disposal of sample tubes after testing to prevent heat transfer fluid remaining on the tube exterior from contacting personnel or the instrument surface.



9. Gently wipe the probe, stir/freeze wire, mandrel and the top of the freezing chamber (in that order) with a soft, clean and dry, lint-free, single-use paper tissue after each test, to avoid contaminating the next sample. Be careful not to bend the probe or stir/freeze wire.
10. Repeating steps 1-9, test two to four more aliquots of the same reference solution or standard to check repeatability and accuracy before running tests on unknown samples. Follow the techniques recommended on page 21, Repeatability Tips. When checking calibration and repeatability with standards or reference solutions, it is usually best to average the readings from three to five aliquots of each sample to avoid error.

If you are running the instrument for the first time, it is recommended that you follow the Clinitrol™ Reference Solution samples with bracketing calibration standards to check the instrument accuracy and linearity over the range of interest.

If the instrument accuracy on the reference solution (and/or calibration standards) is not satisfactory, refer to Chapter 4, Calibration.

If the instrument repeatability on the reference solution (and/or calibration standards) is not satisfactory, refer to Chapter 3.

If the accuracy and repeatability on the reference solution (and/or calibration standards) are satisfactory, you may begin testing unknown samples, using exactly the same test procedure as for the reference solution and standards.

Setup Menu Items

0. Select Setup Item
1. Set Block Bin #
2. Set Sample Bin #
3. Dis/Enable I.D. #
4. Set Stir Amplitude
5. Set Date/Time
6. Dis/Enable Beeper
7. Set Serial Rate
8. Dis/Enable Xon/Xoff
9. Serial Number
10. Select Language
11. Product/Test
12. Data Capture
13. Assistance
14. Set “Buzz” Amplitude
15. Set “Buzz” Point
16. Select Range

Table 3: Setup Menu Items

11. Always wipe the probe, stir/freeze wire, mandrel and the top of the freezing chamber with a soft, clean and dry, lint-free, single-use paper tissue after the last test, to avoid having contaminating material dry on the probe. Be careful not to bend the probe or stir/freeze wire.
12. Leave an empty sample tube in the freezing chamber to prevent debris from entering the well.

The 3250 may be left on continuously. When idle for five minutes or more, it automatically enters standby mode: the fan slows, the freezing chamber warms slightly and the display changes to the date and time. The 3250 remains in the standby mode until another test is needed. It automatically exits from standby mode when any keypad is pressed.

Sample test errors

Occasionally a test will not run to completion and your instrument will display an error message. Refer to the Troubleshooting Table Appendix A at the end of this user's guide for an explanation of a particular message.

Changing operating settings

Your 3250 has been individually set up at the factory for normal operation, but **SETUP** may be required for changing the date and time or other parameters for your individual needs.

NOTE The **Supervisor/Operator** keyswitch must be in the **Supervisor** position to enable use of the **SETUP** menu. If the **SETUP** key is pressed while the Supervisor/Operator keyswitch is in the **Operator** position, a **“Supervisor Key Needed; Press Stop to Continue”** message will be displayed.



Specific details for each setup menu item follow.

0. Select Setup Item

This menu item is displayed first when **SETUP** is pressed and allows either direct selection or sequential selection of a menu item.

- **Direct Selection:** For direct selection, press **START** at **“Select Setup Item”**. The display will change to **“Setup Menu #: 0”**. At **“Setup Menu #: 0”**, enter the number of the desired setup item (from the Setup Menu, Table 3) on the keypad and press **ENTER**. The display will change to the selected menu item.
- **Sequential Selection:** For sequential selection, repeatedly press the > switchpad to step the display forward or < to step the display backward through the setup menu list. The displayed parameter list is cyclic; pressing > at the last item cycles the display to item 0. Continue pressing > or < until the desired menu item is displayed.

Note that while direct, numerical selection is only available at **“Select Setup Item”**, > or < stepping is available from *any* menu position.

When the desired menu item is displayed, press the **START** switchpad to select the item, display the current setting and enable changing the setting.

The current setting is indicated either by the symbol “*” or a numeric value and may be changed by pressing > or < (or using the item-specific instructions below).

Press **ENTER** to store a new setting (or **STOP** to restore the original setting). The display will revert to the title of the parameter selected. Then one may press: **START** to display the new setting, > or < to step to the next **SETUP** item, **STOP** to exit the **SETUP** menu, or **TEST** to change to the **TEST** menu.

1. Set Block Bin #

This menu item displays the current block probe bin setting and allows the setting to be changed.

The block probe bin setting should only need to be changed when a new block probe of a different bin number is installed in your instrument.

Upon entering “**Set Block Bin #**”, the current setting will be displayed. To change the setting, enter your new block probe bin number by means of the numeric keypad. Press **ENTER** to store the new setting or **STOP** to restore the original setting. You may also use the > < keys to step through the available choices. Once you press **ENTER**, you will be asked to confirm the change. Press **ENTER** to confirm.

Changing the block probe bin number forces recalibration of the instrument.

2. Set Sample Bin #

This menu item displays the current sample probe bin number setting and allows the setting to be changed.

The sample probe bin number should only need to be changed when a new sample probe of a different bin number is installed in your instrument. Use the sample probe bin test procedure in the diagnostic tests section (Chapter 5) of this user’s guide to determine the bin number of a replacement probe.

Upon entering “**Set Sample Bin #**”, the current setting will be displayed. To change the setting, enter your new sample probe bin number by means of the numeric keypad. Press **ENTER** to store the new setting or **STOP** to restore the original setting. You may also use the > < keys to step through the available choices. Once you press **ENTER**, you will be asked to confirm the change. Press **ENTER** to confirm.

Changing the sample probe bin number forces recalibration of the instrument.

3. Dis/Enable I.D.

This menu item enables a means of entering an identification number for each sample test result. When enabled, each test prompts for an identification number to be entered via the numeric keypad or optional barcode scanner. The identification numbers entered are displayed and sent to the printer port and the RS-232 port with the sample test results.

ID numbers may not exceed 13 characters.

1. At “**Dis/Enable I.D. #**”, press **START** to display “[on] < **I.D. #** * [off]”. The current setting is indicated by the symbol, “*”.
2. At “[on] < **I.D. #** * [off]”, press < or > to toggle the **I.D. #** option on or off.
3. Press **ENTER** to store the new setting (or **STOP** to restore the original setting).

4. Set Stir Amplitude

This menu item displays the current sample stir amplitude setting and allows the setting to be changed.

1. At “**Set Stir Amplitude**”, press **START** to display “**Amplitude = xx**”.
2. At “**Amplitude = xx**”, look across the tip of the stir/freeze wire from the side to view and estimate the sample stir vibration amplitude. If properly adjusted, the stir/freeze wire should vibrate principally fore and aft and should never strike the probe.

The recommended stir amplitude adjustment procedure may be found in Chapter 5, Troubleshooting and Service. Pressing > increases the stir amplitude; pressing < decreases the stir amplitude.

3. Press **ENTER** to store the new setting (or **STOP** to restore the original setting).

5. Set Date/Time

This menu item enables changing the date/time format and resetting the date and time.

At “**Set Date/Time**”, press **START** to display the current date and time. Any change must be made in this order:

1. Use < to toggle to the date format you require (“**mm/dd/yy**” or “**dd/mm/yy**”).
2. Use > to toggle to “**24hr**” format, “**am**” or “**pm**”, as required.
3. Press **CLEAR** to clear the entire setting.
4. Enter the current date and time (including zeros), via the numeric keypad, one digit at a time from left to right. Time must be entered in 24-hour format.
5. Use > to toggle “**24hr**” format to “**am**” or “**pm**”, as required.
6. Use < to toggle to the date format you require (“**mm/dd/yy**” or “**dd/mm/yy**”).
7. Press **ENTER** to store the new setting (or **STOP** to restore the original setting). If an invalid setting is attempted, the instrument will reject the setting and beep three times when **ENTER** is pressed.

6. Dis/Enable Beeper

The 3250 keypad in itself has no audible indication that a key has been adequately pressed. The “**Dis/Enable Beeper**” menu item enables an audible indication.

1. At “**Dis/Enable Beeper**”, press **START** to display “[on] < beeper * [off]”. The current setting is indicated by the symbol, “*”.
2. At “[on] < beeper * [off]”, press < or > to toggle the keypad beeper on or off. Neither selection will affect the invalid-selection beeper except that, when the keypad beeper is on, an invalid selection will invoke two beeps, when off, only one.
3. Press **ENTER** to store the new setting (or **STOP** to restore the original setting).

7. Set Serial Rate

This menu item enables changing the serial rate of the data sent to the RS-232 port.

1. At “**Set Serial Rate**”, press **START** to display “**Serial Rate = xxxx**”.
2. At “**Serial Rate = xxxx**”, the serial-port baud rate may be reset by means of the < or > key to either 1200, 2400, 4800, 9600, or 19200 baud.
3. Press **ENTER** to store the new setting (or **STOP** to restore the original setting).

8. Dis/Enable Xon/Xoff

This menu item enables or disables the Xon/Xoff “handshaking” protocol for RS-232 communication.

1. At “**Dis/Enable Xon/Xoff**”, press **START** to display “[on] < Xon/Xof * [off]”. The current setting is indicated by the symbol, “*”.
2. At “[on] < Xon/Xof * [off]”, press < or > to enable or disable serial-port Xon/Xoff handshaking.
3. Press **ENTER** to store the new setting (or **STOP** to restore the original setting).

NOTE Sending a **CTRL-S** from the connected PC will suspend RS-232 output until you send a **CTRL-Q**. While suspended, data

will accumulate in the UART output buffer. However, output buffer memory is limited, and data will be lost if the output remains suspended for too long.

9. Serial Number

At “**Serial Number**”, press **START** to display the instrument serial number (“**Serial #: 123**”). Press **STOP** to return to the setup menu. This number is set by the factory and cannot be changed by the operator.

10. Select Language

This menu item enables selecting one of the alternate languages.

1. At “**Select Language**”, press **START** to display the current setting.
2. Press < or > to select one of the available languages.
3. Press **ENTER** to store the new setting (or **STOP** to restore the original setting).

11. Product/Test

Product/Test is for factory use only and has no field function.

12. Data Capture

Pressing **START** at this SETUP menu item will bring you into an ON/OFF selection menu. When set to **ON**, the freezing curve output data will be presented to the serial port independent of the system’s one-way hold feature. This data is updated every 100ms after crossing 0°C and may be captured with any RS-232 compatible computer program for use in plotting freezing curves.

13. Assistance

Pressing **START** at this SETUP menu item will present you with information on how to contact Advanced Instruments for supplies and service. Important settings information which may be needed by our service personnel will also be presented.

14. Set “Buzz” Amplitude

NOTE The amplitude of the freeze pulse has been optimized by the factory. Adjustment of this setting is recommended only under the supervision of an authorized service technician.

This menu item displays the current “buzz” amplitude setting and allows the setting to be changed. The number displayed has no unit of measure and may vary from assembly to assembly.

1. At “**Set Buzz Amplitude**”, press **START** to display “**Amplitude = xxx**” and activate a one-second freeze pulse.
2. Each press of the **START** keypad will produce an additional one-second freeze pulse.
3. Pressing the “>” key will increase the setting up to a maximum of 255. Pressing the “<” key will decrease the setting to a minimum of 150.
4. Press **ENTER** to store the new setting (or **STOP** to restore the original setting).

15. Set “Buzz” Point

This menu item enables setting the temperature at which crystallization is induced by the freeze pulse (buzz) in each range.

Most freezing point osmometers supercool all samples in the 0-2000 mOsm range to approximately 3000 on the mOsm scale. The 3250 buzz points default to 3000 for the lower range and 4800 for the upper range. Because the test results may be affected somewhat by the amount of supercooling, these default buzz points are recommended for general use and for the most reliable comparison of data.

Certain fluids may not freeze reliably at the default buzz point, however, or may give more repeatable results with either more or less supercooling than the default buzz point provides. The 3250 is designed to accommodate these, as well as the more ordinary types of samples.

At “**Set “Buzz” Point**”, press **START** to display the current crystallization setting, displayed as “**Buzz” Point = xxxx**”. To change the crystallization point:

1. At “**Buzz” Point = xxxx**”, the present setting must be cleared before the buzz point can be changed. Press **CLEAR** to clear the

setting. Alternatively, the < > keys may be used to increase or decrease the value, one digit at a time.

2. Enter the desired buzz point (including zeros), via the numeric key-pad, one digit at a time from left to right. The 3250 buzz point can be set between 2000 and 5400 on the mOsm scale in either low or high range.

NOTE The buzz point should be at least 1200 mOsm higher than the expected test value.

3. Press **ENTER** to store the new setting (or **STOP** to restore the original setting).

NOTE Each time the buzz point is changed, the instrument displays the message “**Check Calibration**”, a reminder that the instrument calibration is affected by the amount of supercooling.

16. Select Range

This menu item enables optimizing the 3250 test parameters for a wider osmolality range than can be accommodated by a single set of test parameters. Two ranges are provided:

- Low range sets the 3250 to operate between 0 and 2000 mOsm.
- High range sets the 3250 to operate between 1500 and 4000 mOsm.

Independent calibration parameters are maintained for each range (see Chapter 4 for calibration instructions). Generally, each range requires a different crystallization temperature (“buzz” point). See item 15, above.

To change the test range:

1. At “**Select Range**”, press START to display “[**low**] range >[**high**]”.
2. At “[**low**] range >[**high**]”, press < or > to toggle between the low and high ranges.
3. Press **ENTER** to store the new setting (or **STOP** to restore the original setting).

NOTE Each time the range is changed, the instrument displays the buzz point for the range selected.

Using the RS-232 port

The RS-232 port (see Figure 6) allows you to output to an external device, such as a computer. Almost every item of information displayed by your instrument is also transmitted over the RS-232 port, including test results, all error messages, and most display data from the diagnostic menu.

The default serial data rate for communications is 9600 bps (bits per second), though you may alternatively select 1200, 2400, 4800, and 19200 bps.

The DB-9 RS-232 port on your instrument conforms to the DTE EIA-232C standard and can reliably communicate over shielded cable up to 10 meters in length, depending on the baudrate you use.

Note that your instrument is only designed to support unidirectional communication with an external device. At this time, there is no protocol for bidirectional communication.

For a sample RS-232 Port Setup, please see the RS-232 Supplemental Information (Appendix E) at the end of this user's guide.

NOTE This instrument requires the use of a null modem RS-232C cable. There are several variations on null modem cables. Advanced Instruments recommends that you purchase a RS-232C cable direct from our factory.

3 Standards & Quality Control

Repeatability and accuracy

Two important measures of quality control are repeatability and accuracy. Repeatability is sometimes called “reproducibility”, sometimes “precision”. However described, repeatability is essential in nearly all forms of measurement, and is fundamental to accuracy. Repeatability is not accuracy; repeatability underlies accuracy. Repeatability is a measure of the ability of a method to obtain the same result time after time on the same sample.

Repeatability or precision is usually quantified as the standard deviation (S.D.) of a set of measurements normally distributed about a mean: ± 1 S.D. about the mean denotes the range of values within which 68% of the measurements will fall; ± 2 S.D., 95%.

By contrast, accuracy is a measure of how close to the “true” value a method or measuring device has come. One can repeat without being accurate, but one cannot be accurate without repeating well.

Standards and controls

To be accurate, all measurements ultimately must be referred to highly reliable independent standards. Advanced[®] Osmometers

are calibrated with standards consisting of stable sodium chloride solutions of known freezing points which bracket those of the expected unknowns. These standards are related to the most fundamental work on freezing points of dilute solutions published and are traceable to the National Institute of Standards and Technology (formerly the National Bureau of Standards). We also use and provide a sodium chloride reference solution for checking osmometer accuracy at a point close to the osmolality of normal blood serum.

Osmometers used for testing biological solutions should be checked additionally by making determinations on actual biological solutions or controls formulated to simulate biological solutions. Several biological controls are commercially available and may be recommended or specified in your area. Contact your Advanced Instruments representative to obtain Protinol® Protein-based Controls or Renol™ Urine Osmolality Controls. Please check with your professional associations and regulatory bodies for their guidelines and/or requirements, and refer to our recommendations contained herein.

Maintenance of standards

Doubts about the accuracy of standards destroy confidence in the accuracy of the test. Advanced® osmometer standards are specified to be within very close tolerances. Several of the sodium chloride-based reference and calibration solutions designed for the Advanced® Osmometers are sealed in glass ampules to insure against any possibility of alteration during transit or storage. However, we recommend that you test samples from each newly-received lot and maintain records of your test results on osmometer standards for reference.

Quality control implementation

The following recommendations outline the minimum requirements for quality control:

1. Read, understand and follow the instructions and recommendations in the user's guide as closely as practical.

2. The instrument repeatability and accuracy should be checked each time it is used, as recommended in step 9 of the sample test procedure section. Run at least two levels of standards or controls daily. Prepare, maintain and follow additional verification procedures specifically adapted to your own laboratory requirements as necessary.
3. Repeatability tips are specified in the previous chapter. It depends to a certain extent upon operator technique and can usually be improved by carefully following the suggestions in the repeatability tips section.
4. Instrument accuracy is determined by comparing your results on precisely-known standards and/or controls with their specified values. The instrument accuracy is adjustable; if it is unsatisfactory, it should be corrected by recalibrating, as instructed in Chapter 4. However, it has been shown that frequent unnecessary recalibration will introduce inaccuracy. The calibration of a freezing point osmometer in good condition and properly operated *will not shift or drift*.
5. Follow quality control requirements of your associations and regulatory bodies.
6. Advanced Instruments recommends the following usage schedule of quality control materials to ensure proper instrument operation, result reporting, and Good Laboratory Practice:
 - a. Clinitrol™ 290 Reference Solution should be used daily to ensure that the instrument is performing properly and has not shifted.
 - b. If your laboratory is required to run matrix-based control solutions, Protinol® Serum Protein Control and Renol™ Urine Control should be run daily to monitor precision and create an audit trail that can be tied to patient results.
 - c. Linearity should be verified using the five-level linearity set as required by your laboratory.

Notes:

4 Calibration



*This chapter describes the procedure for calibrating your instrument. If you have questions or problems regarding the calibration procedure, please consult **Chapter 5 — Troubleshooting & Service**.*

Calibration procedure

Aside from requiring manual sample introduction, calibration of the 3250 is automatic. Following the procedure suggested below, you simply select **CALIB** and initiate freezing-point tests on each of two calibration standards required for the selected range.

The calibration standards required are:

Low range: 100 and 1500 mOsm/kg H₂O

High range: 1500 and 3000 mOsm/kg H₂O

Internally, the 3250 accomplishes calibration in two steps for each range. First, it records the raw means of the results of freezing point tests on standards at each of the two calibration levels. Then it performs the necessary conversion calculations and calibrates the display. Each range is independently calibrated.

Check the calibration frequently, as recommended in Chapter 2, but do not recalibrate when the calibration is satisfactory. It has been shown that unnecessary recalibration will introduce inaccuracy. The calibration of a freezing point osmometer in good condition and properly operated *will not shift or drift*.

Both the **High** and **Low** ranges were initially calibrated at the factory. However, each time the buzz point is changed, the calibration should be checked and recalibrated if necessary. Also, anytime the sample or block probe bin numbers are changed, recalibration will be required.

The calibration procedure is as follows:

1. At “**Osmometer Ready**” (or the date and time standby display), press **CALIB**. The **CALIB** key will light and the display will quickly change to “**Calibration**”, then prompt you for the first calibration standard.

If the sample probe is replaced, the sample probe bin # must be determined and set before the 3250 can be recalibrated.

2. Load the standard sample prompted by the display into the freezing chamber and press **START**. The display will change to “**Cooling Sample**”, the operating head will lower, a calibration test will be run and the results will be displayed and recorded internally. Continue loading and testing standard samples at the first calibration level until prompted by the display for a sample at the second calibration level.

Three samples are required at the first calibration level of the Low range. *Do not load samples at the second calibration level until prompted by the display; to do so may cause a “Calibration Out of Range; Repeat Calib” error message.*

At least six samples are required at the second calibration level of the Low range, and at each calibration level of the High range.

When calibration tests have been acceptably completed at the first calibration level, the instrument will calculate and store the mean of the raw values of the closest tests, then prompt the operator for samples at the second calibration level. The calibration will not actually be changed until all calibration tests have been acceptably completed at both calibration levels.

When six calibration tests have been acceptably completed at the second calibration level, the instrument will calculate and store the mean of the raw values of the closest tests, recalibrate the readout and display “**Calibration Complete**”.

3. At “**Calibration Complete**” one may press **STOP** to return to “**Osmometer Ready**”, **CALIB** to restart the calibration sequence, or **START** to lower the operating head and start a regular freezing point test.

Calibration notes

- The 3250 will retain its previous calibration data until it completes a recalibration and the display reads “**Calibration Complete**”.
- Although it is possible for the 3250 to detect certain gross calibration errors such as reversal of the standards, it remains the responsibility of the operator to be sure to introduce accurate standards of the specified freezing point values.
- Pressing **STOP** during recalibration will cancel the current calibration test but allow calibration to be resumed with another sample. Pressing **STOP** a second time will cancel recalibration and retain the previous calibration.
- Good operating technique is as important during calibration as during normal operation (see page 21, Repeatability Tips). If the calibration test results are not acceptably repeated throughout the six tests at each calibration level, the instrument will report “**Calibration out of Range**” and the entire calibration procedure must be redone. If the repeatability problem recurs despite good operating technique, please call or write immediately for Hot-Line® service.

NOTE Pressing **ENTER** in **Set Block Bin #** or **Set Sample Bin #** will erase calibration and force a full recalibration of the instrument.



NOTE  If the instrument has lost all previous calibration data, or you have reset the block or sample bin numbers, you will see the message "**Recalibration Needed**". Pay close attention to the displayed prompts. You will be requested to run a slightly different sequence than described above.

5 Troubleshooting & Service



This chapter contains very basic information to help you solve problems that might arise with your osmometer. Please read all instructions very carefully, and if a solution cannot be found in this guide, contact Advanced Instruments for Hot-Line® Service.

Service & maintenance cautions

- Do not perform any service or maintenance yourself, except as detailed in the User's Guide.
- Unplug the power cord prior to opening or removing covers, or else you may be exposed to electric shock, excessive temperatures, or mechanical hazards.
- Performing service or maintenance not detailed in the User's Guide, with or without a Service Manual, should only be done by a qualified service technician.
- Never restrict airflow into or out of the product. Occasionally, check the air vents for blockage.
- Wipe the exterior of the product with a soft, damp cloth as needed. Using cleaning products other than those specified, may discolor or damage the finish.
- If the product requires service for any of the following reasons, unplug the product from the electrical outlet and refer service to a qualified service technician.
 - The power cord, extension cord, power strip, or power input module is damaged.
 - Liquid has been spilled into the interior of the product.

- A foreign object has fallen into the product.
- The product has been dropped or damaged by a falling object.
- There are noticeable signs of overheating or a burning odor.
- The product does not operate normally when you follow the operating procedures.
- The main supply fuse(s) or any internal fuse(s) continually fail.
- A discharge of static electricity from contact with the human body or other conductor may damage system boards or static sensitive devices. Never perform internal maintenance without following recommended static protection procedures.
- The product is equipped with operator accessible fuses. If a fuse blows, it may be due to a power surge or failure of a component. Replace the fuse only once. If the fuse blows a second time, it is probably caused by failure of a component part. If this occurs, refer service to qualified service personnel. Always replace the fuse with one of the same rating, voltage, and type. Never replace the fuse with one of a higher current rating.
- When servicing the product, use only factory-specified parts.
- The product contains an integral lithium battery that is not user-serviceable.

WARNING: When returning this product for service, or shipping this product to a second location, remove all heat transfer fluid and hazardous specimens and decontaminate the product before packaging for shipment. If the product cannot be decontaminated, consult with your shipping agent on appropriate packaging and marking.



Obtaining service

Before contacting Advanced Instruments for Hot-Line® Service, be sure to read through this user's guide for instructions on routine adjustments,

instrument care and troubleshooting. If this information does not solve your problem, call the appropriate number below.

- 800-225-4034 (toll-free within the USA and Canada; after normal business hours, dial extension 2191)
- +US 781-320-9000 (elsewhere)
- 781-320-0811 (fax)

If you purchased your instrument outside of the U.S. or Canada, please contact your Advanced Instruments authorized dealer for service or repair.

When contacting our service personnel, please have ready the model and serial numbers from the label on the back of your instrument, your user's guide or service manual, and the symptoms of your problem. You should use a telephone as close to your instrument as possible to facilitate making recommended diagnostic checks. If you need to order parts or service, a purchase order from your purchasing agent will be necessary.

A service technician may assist in making minor repairs over the phone, providing you with recommended parts (or part numbers), or may issue an authorization to ship the instrument for factory repair.

To return an instrument for repair or replacement:

1. Notify our service department to obtain an RMA (Returned Material Authorization).

CAUTION The heat transfer liquid contains hazardous chemicals. Consult the material safety data sheet (MSDS) and use appropriate personal protective equipment.



2. Open the heat transfer fluid compartment in the front of the instrument. Remove the smaller plastic tube from the heat transfer fluid container; temporarily leave the larger plastic tube in the heat transfer fluid container.
3. Place an empty sample tube in the freezing chamber. Run the Head Up/Down Test for a few minutes to pump the heat transfer fluid

remaining in the system out into the heat transfer fluid container. Remove, cap and retain the heat transfer fluid container.

4. Tape or tie a small plastic bag over the ends of the heat transfer fluid plastic tubes and fluid filter to retain any leakage. Lower the operating head into the empty sample tube in the freezing chamber to protect the probe during shipment.
5. Carefully pack and send everything except supply items.

Be sure to prepay for any shipment to the factory. Advanced Instruments cannot accept collect shipments without prior factory approval. Please insure the shipment, or accept the damage risk.

Routine maintenance

Daily. Checks you should perform to keep your instrument in peak condition are:

1. Calibration Repeatability: Readings each day on separate aliquots of the same standards should not deviate beyond the repeatability and drift limits indicated in Appendix B.
2. Heat-transfer fluid: Heat-transfer fluid will evaporate from the well and droplets will cling to the sample tubes as they are removed. Check the contents of the heat transfer fluid reservoir occasionally; replace the fluid when the level drops below the "REPLACE" line on the bottle.

CAUTION  The heat transfer liquid contains hazardous chemicals. Consult the material safety data sheet (MSDS) and use appropriate personal protective equipment.

Monthly. Maintenance you should perform:

Clean or replace the air filter (Figure 4, item 7) monthly; replace as necessary. A dirty filter affects the ability of the fan to cool internal components; a rise in internal temperature may adversely affect reliability.

Shutdown and storage

Overnight or weekend:

1. Rinse the probe clean with distilled water and wipe it dry.
2. Turn off the instrument, if desired.
3. Do not cover the instrument unless it is turned off.

One week or longer:

1. Rinse the probe clean with distilled water and wipe it dry.
2. Turn off the instrument.
3. Unplug the power cord from the wall outlet.
4. Cover the instrument.

Troubleshooting checks

Check operational requirements. If you are experiencing difficulties with your instrument, first carefully review the operational requirements listed in the product specifications and the recommended setup and operating procedures. Check the heat transfer fluid level. Make sure that the heat transfer fluid pump is fully primed.

Check fuses. You will find the power switch and fuse holder beside the power cord connector on the back panel of the instrument. Switch the power switch to the off position and disconnect the power cord. Use a small flat-bladed screwdriver or similar tool to pry out the fuse holder. Visually check for a blown fuse. If there is any doubt, test the fuses with a continuity checker or ohmmeter or simply replace them with new fuses.

Check probe and stir wire. Run the A/D Test and the Probe Bin Test to evaluate the probe operation. Refer to the Mandrel, Probe, and Stir/Freeze Wire Alignment section for proper alignment of the sample probe and the stir wire. Refer to the Stir/Freeze Amplitude Adjustment section to properly adjust the stir and freeze amplitudes.

Check error messages. The software of your instrument is designed in such a way that any incomplete task will be associated with an error message, many self-explanatory, that will help you discover the source of your problem. You can find all error messages and descriptions of what they mean in Appendix A.

Internal diagnostic tests

The diagnostic menu allows any of a series of tests to be run to check one functional subsystem of the instrument, or to perform some necessary adjustment or setup.

An item on the **TEST** menu may be selected in either of the following two ways:

- At “**Select Test Item**”, repeatedly press the > key to step the display forward or < to step the display backward through the list. The list is cyclic; pressing > at the last item cycles the display to item 0. Continue pressing > or < until the desired test is displayed. While the desired test is displayed, press the **START** key.
- Or, at “**Select Test Item**”, press the **START** key. The display will change to “**Test Menu #: 0**”. Type the number of the desired test on the numeric keypad. The “**0**” on the display will change to the number typed, if valid. Then press **ENTER**. The display will show the selected test. Next, press the **START** key.

At “**Select Test Item**”, the following tests are available:

0. Select Test Item
1. Statistics
2. Recall Results
3. A/D Tests
4. Stir/Freeze Test
5. Probe Bin Test
6. Barcode Test
7. Display/Print Test
8. Beeper Test
9. Keypad Test
10. Head Up/Down Test
11. Event Record

Descriptions of the test menu items and instructions for their use follow:

1. Statistics

The statistics option allows you to recall the stored results from a selected last number of tests and calculate their average, standard deviation

and coefficient of variance. To use this option, use the following procedure.

1. At “**Osmometer Ready**”, press the **TEST** key and then the **>** key, respectively.
2. Press **START** to enter the statistics mode. Your instrument will request the number of tests to be considered when computing statistics. Enter a number from 2 to 30.
3. Press the left **ENTER** key to display the average of the selected number of last results.
4. Press the left **<** key to display the standard deviation of the selected number of last results.
5. Press the left **<** key a second time to display the coefficient of variance of the selected number of last results.
6. To return to the diagnostic menu, press the **STOP** switchpad.
7. To return to “**Osmometer Ready**”, again press the **STOP** key-pad.

NOTE The instrument will output all three values to the printer and serial port at step 3. For example:

<p>Based on Last 5 Samples AVG = 901.40 mOsm Std Dev = 1.14 mOsm CV = 0.13%</p>

2. Recall results

The recall results feature of the Model 3250 allows you to display and print the results of your last 30 tests. If you need to see any or all of these results, take the following steps.

1. At “**Osmometer Ready**”, press the **TEST** key to enter the diagnostic test menu.

2. Use the > or < keys to cycle through your choices until you see “**Recall Results**”.
3. Press **START** to enter the recall results mode. Your instrument will display and print the data of the most recent test result.
4. Use the > or < keys to see the results stored in the recall buffer.
5. Continue in this manner until you have recalled the necessary results. For example:

```
#30 09/06/2005 01:04:29 PM
ID NONE
Result = 903 mOsm
```

6. To return to the diagnostic menu, press the **STOP** key.
7. To return to “**Osmometer Ready**”, press the **STOP** key again.

3. A/D Tests

This set of tests may be used to test the block probe, the cooling assembly and the sample probe. The A/D tests may also be used to check the accuracy of the A/D conversion channel or to monitor the A/D channel for drift over time or temperature (by temporarily replacing the sample probe with a precision resistor).

On entry, the A/D tests will display “[**Start**] Ready?”.

At “[**Start**] Ready?”, pipette or measure a sample of 1500 or 3000 m°C standard into a sample tube, place the tube in the freezing chamber, and press the **START** key.

On entry, the A/D tests display the target cooling block temperature, the channel being read, and the current channel reading or duty cycle. The display is in the form, “**off Blk NNNN.NN ohm**”, where “**off**” indicates that a target temperature has not yet been selected, “**Blk**” indicates that

the block probe channel is being tested, “NNNN.NN” is a numeric readout of the probe, and "ohm" indicates the units of the readout. These readings are updated continuously.

Pressing the < key sequentially changes the target cooling well block temperature from “off” to “+1”, to “-8”, in steps of -1°C to “off”, etc.

Pressing the > key sequentially changes the channel and readout units from block probe resistance in ohms, to sample probe resistance in ohms, to block temperature in tenths of a degree Celsius, to sample temperature in tenths of a degree Celsius, to cooling block duty cycle (“NN %” on), to block resistance in ohms, etc.

CAUTION The temperature values displayed are based on the block probe resistance which the instrument is configured for. Thus, if the block probe bin number has been incorrectly set, both the displayed temperatures and resistances will be incorrect, as well as the actual temperature of the sample cooling well.



While the target temperature is “off”, the block probe is warm and its resistance should be less than 4,990 ohms. As the temperature is set colder, the resistance will increase.

Press **STOP** to raise the operating head and exit to the test menu.

4. Stir/Freeze Test

This menu item enables visually and aurally checking the stir and freeze vibration amplitudes. Please refer to the “Stir/Freeze Amplitude Adjustment” section shown later on in this chapter for instructions.

5. Probe Bin Test

This test is used to determine the resistance and bin number of the sample probe at a specific temperature (-0.093°C). It is essentially the same as any other sample test except that the sample probe resistance and correct bin number are determined and displayed, in place of the sample freezing point.

On entry, the probe bin test will display “[Start] Ready?”.

At “[Start] Ready?”, pipette or measure a sample of probe bin-setting fluid into a clean sample tube, place the tube in the freezing chamber and press the **START** key. The 3250 will run a special freezing-point test to determine the sample probe resistance and bin number.

NOTE In emergency, H₂O may be used in place of probe bin-setting fluid for this test. The bin number thus determined will be acceptable for bin setting though the probe resistance displayed will be that at the freezing point of the H₂O sample used and will be different from that at a freezing point of -0.093°C.



The display will flash “**Cooling Sample**” (as in a normal test) until the sample probe resistance reaches 4990 ohms. Then the test proceeds normally except that the display is in ohms rather than mOsm. At the end of each test, the final display will be the test result in ohms and the sample probe bin number (e.g., “**12345.67 Ohms Bin 10**”).

A test in progress can be stopped by pressing the **STOP** key. Another test may be run by replacing the sample and pressing **START** again. At a specific freezing point, each probe has a unique resistance which should vary very little from test to test. Therefore, the results of this test may be used as a troubleshooting aid, in conjunction with the sample-probe checks described in section “Sample Probe Checks and Replacement,” shown later in this chapter.

Record the sample probe resistance and bin number in the service log at the end of this user's guide (and/or other convenient location); then press the **STOP** key. The display will revert to “**Probe Bin Test**”.

Press **SETUP** and use the procedure “Set Sample Bin #” described in Chapter 2 to reset the sample probe bin setting as necessary.

NOTE Recalibration is required each time the sample probe is replaced and/or the sample probe bin number is reset.



If running this test produces the message, “**Reset Probe Configuration**” instead of the sample probe resistance and bin number, the sample probe bin number is not available from the instrument memory and must be reset. Press **SETUP** and use the procedure “Set Sample Bin #” described in Chapter 2 to preset a random sample probe bin number, such as “5”. Then press **TEST** and rerun the probe bin test. Finally, as necessary, press **SETUP** and use the “Set Sample Bin #” procedure to correct the sample probe bin setting. If the “**Reset Probe Configuration**” message persists, please refer to Chapter 5 “Obtaining Service” to get help.

6. Barcode Test

This test performs a continuous check of the barcode port.

Press the **START** key to enter the test. At “[**START**] Test [**STOP**]” you may press **START** once the barcode scanner is connected, or press **STOP** to return to the main menu.

After you press **START** you may begin scanning barcodes. If your code will not scan, check the manufacturer’s user’s guide to verify correct setup of the scanner for your symbologies.

Press **STOP** to exit to the test menu.

NOTE This test will only work after power on diagnostics have been completed.



7. Display/Print Test

This test is a simple check of the display and printer. On entry, a series of characters should scroll across the display (and a single line of the same characters should print out on the printer). The characters displayed have been chosen to illuminate every dot in the character matrix. This makes it possible to distinguish any dots that no longer work, on the printer as well as the display.

Press **STOP** to exit to the test menu.

8. Beeper Test

This test exercises the beeper.

1. On entry, “[**on**] beeper [**off**]” is displayed. Press the < key to cause the beeper to beep repeatedly; press the > key to stop the beeper.
2. Press **STOP** to exit to the test menu.

9. Keypad Test

This test enables checking each key on the keypad, as well as the lamps of each illuminated key. As each key is pressed, its name should be displayed and the lamp of each illuminated key should light.

Press the **STOP** key twice to exit to the test.

10. Head Up/Down Test

This test enables selectively lowering and raising the operating head. It may be used to check the operation of the head motor drive, to prime and drain the heat transfer fluid pump, and to check for obstructions in the fluid system.

CAUTION To protect the sample probe, place a sample tube in the freezing chamber before running this test.



1. On entry, “[**START**] Test [**STOP**]” is displayed. Press **START** to continuously cycle the operating head down and up.
2. Press **STOP** to raise the operating head and exit to the test menu.
3. Press **STOP** to exit from the test menu to “**Osmometer Ready**” (if the initial diagnostics had not been completed when the test menu was entered, the 3250 will complete them before “**Osmometer Ready**” is displayed).

11. Event Record

This menu item displays the last 200 recordable events of the instrument, and is used when servicing the instrument.

Fuse replacement

If you determine that your instrument is not functioning because of blown fuses, you will need to replace the fuses using the following procedure:

1. Switch the power switch to the off position and disconnect the power cord.
2. Use a small flat-bladed screwdriver or similar tool to remove the fuse holder door. Remove the fuse holder.
3. Double-check the values marked on the fuses. The Model 3250 will automatically adjust for voltages between 100VAC and 250VAC, but appropriately rated fuses (2) must be installed. Use 5 x 20 mm, 250V, time delay (Type T): 2-Amp.
4. Re-install the fuse holder into the back of the instrument.
5. Reconnect the power cord and switch the power switch to the on position. The instrument should start up as normal.

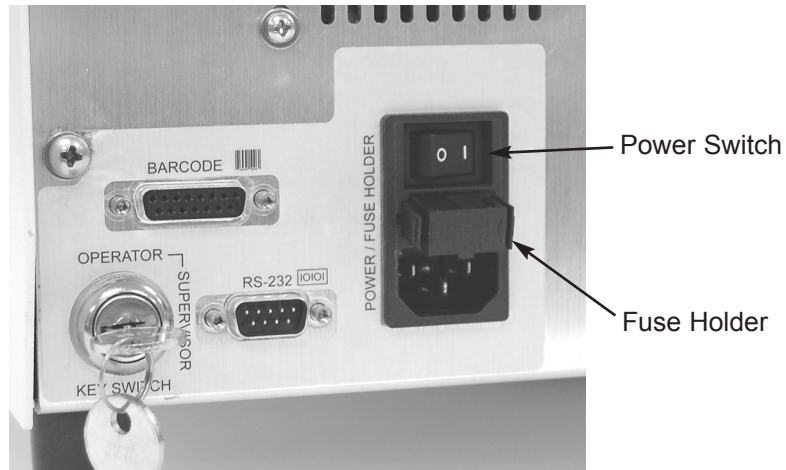

Figure 7: Fuse Replacement

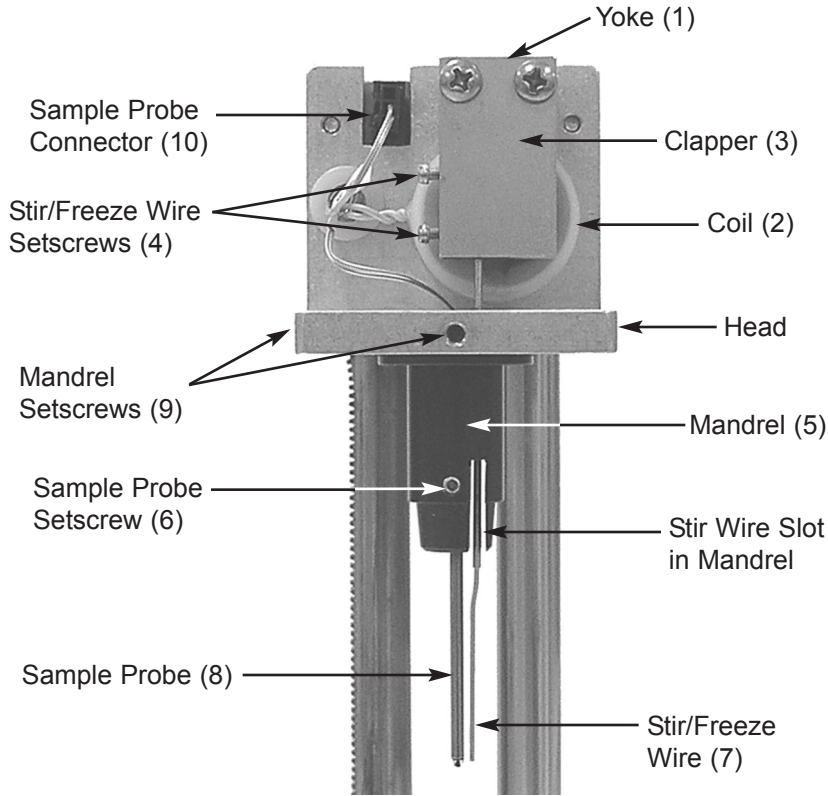

Figure 8: Operating Head

Sample probe checks and replacement

Glass-tipped probes are very sensitive and quick to respond but are somewhat susceptible to pushing, pulling and bumping damage. Such damage often causes varying electrical leakage to ground through the sample and may usually be detected via close visual inspection or disconnecting the connector and checking the probe resistance. This can be done in place without disturbing the physical adjustment of the probe.

The following procedure is recommended for testing and/or replacing the sample probe:

1. Place an empty sample tube in the freezing chamber (Figure 4, Item 8) to catch any extraneous material that might fall in.



2. Unplug the instrument; it is not sufficient to just turn it off.
3. Remove the head cover by removing the two top screws and pulling the cover straight up.
4. Unplug the sample probe connector (Figure 8, Item 10). The probe leads are electrically accessible through the side slots in the connector. Use care not to touch or bend the connector pins. Soil or salt from your fingers can increase the electrical resistance of the connection.
5. With the probe at room temperature (20°C - 25°C), the resistance between the probe leads should be in a range of 2000 - 2800 ohms. Immerse the tip of the probe into a container of ice and water (~0°C). The resistance should rapidly increase to a range of 5500 - 6100 ohms.

With the tip of the probe immersed in a concentrated NaCl solution (do not wet the probe leads or connector with the salt water), the resistance between either probe lead and the solution should be greater than 20 megohms. Carefully rinse the probe clean following this test.

Probe damage is indicated by any deviation from the resistance parameters given above.

If sample probe replacement is indicated:

6. Loosen the two setscrews (Figure 8, Item 9) holding the mandrel in the head chassis. Lower the probe and mandrel down over the stir wire.
7. Fit a new sample probe by pushing the probe connector and wires up through the hole in the head chassis before seating the mandrel.

Then raise the mandrel up around the stir wire. Align the mandrel so the stir-wire channel is perpendicular to the front edge of the chassis and so the flange is flush, with no gaps between the flange and the underside of the chassis. Retighten the two setscrews to hold the mandrel in place. Do not overtighten -- overtightening will damage the mandrel.

8. The probe length is factory adjusted to the mandrel, and should not require further adjustment. Proper positioning of the probe and stir wire can be quickly confirmed with the probe and stir-wire alignment tool provided with the instrument, or the method described in the “Mandrel, Probe, and Stir/Freeze Wire Alignment” section shown later on in this chapter.
9. Reconnect the probe connector on the head chassis, taking care once again not to touch or bend the connecting pins.
10. Arrange the leads so that they will not touch the clapper (Figure 8, Item 3) or be pinched when the head cover is replaced.
11. Replace the head cover and its two attaching screws.
12. Reconnect the power cord and turn the instrument on.
13. Make sure the **Supervisor/Operator keyswitch** is in the **Supervisor** position while using the **SETUP** and **CALIB** menus (see Figure 6 and Chapter 2, “Supervisor/Operator Keyswitch”).
14. When the operating head rises and “**Press START to Continue**” begins to scroll across the display, press the **START** key.
15. When the display changes to “**Osmometer Ready**”, press the **TEST** key. The display will change to “**Select Test Item**”.
16. At “**Select Test Item**”, repeatedly press the > key until the display reads “**Probe Bin Test**”.
17. At “**Probe Bin Test**”, press **START**. The display will change to “**[Start] Ready?**”.

18. At “[**Start**] **Ready?**”, remove the empty sample tube from the freezing chamber, pipette or measure a sample of probe bin setting fluid into a clean sample tube, place the tube in the freezing chamber and press the **START** key. The 3250 will run a special freezing point test to determine the sample probe resistance and bin number.

NOTE In emergency, H₂O may be used in place of bin-setting fluid for this test. The bin number thus determined will be acceptable for bin-setting though the probe resistance displayed is that at the freezing point of the H₂O sample used, and will be different from that for bin-setting fluid.



19. Record the sample probe resistance and bin number in the Service Log at the end of this user's manual; then press the **STOP** key. The display will change to “**Probe Bin Test**”.
20. Press **SETUP** to enter the **SETUP** menu, then repeatedly press the key until the display reads “**Set Sample Bin #**”.
21. At “**Set Sample Bin #**”, press the **START** key. The display will report the current sample bin number setting.
22. If the current sample bin number setting is not the same as that just determined, enter the correct bin number by means of the numeric keypad; then press the **ENTER** key. The display will change to “**Set Sample Bin #**”; then press the **STOP** key to return to “**Osmometer Ready**”. If the current sample probe bin setting is the same as that just determined, simply press the **STOP** key twice to return to “**Osmometer Ready**”.
23. Press the **CALIB** key and calibrate the instrument as recommended in Chapter 4. Recalibration is required each time the sample probe is replaced.

Mandrel, probe and stir/freeze wire alignment

Probe and stir/freeze wire alignment using the alignment tool (see Figure 9):

Proper alignment and adjustment of the mandrel, probe and stir/freeze wire are of utmost importance to assure accuracy, precision and proper operation of the instrument.

NOTE After making any probe and/or stir/freeze wire adjustments, the instrument calibration must be checked and adjusted as necessary.

To facilitate positioning of the probe and stir/freeze wire, a probe alignment tool is included with the instrument and with each replacement sample probe. Replacement probes for the 3250 are pre-mounted in a mandrel at the proper vertical location. To realign the probe and/or stir/freeze wire, use the following procedure:

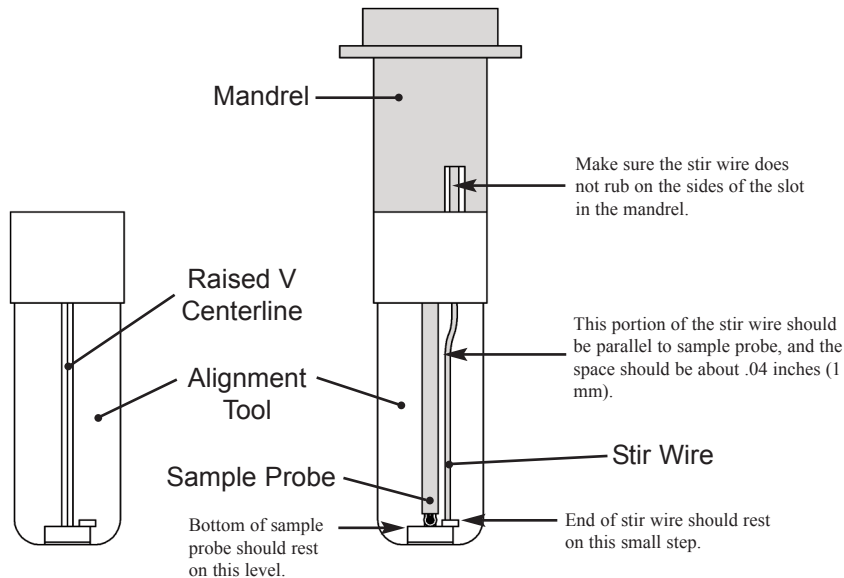

Figure 9: Probe and Stir/Freeze Wire Alignment

1. Slide the tool squarely up onto the mandrel, round end first, with the stir/freeze wire located as shown in Figure 9.
2. Bend the metal probe stem gently by hand, as necessary, to align the probe along the RAISED V CENTERLINE of the probe alignment tool.
3. With the alignment tool squarely up on the mandrel, the bottom of the probe should rest on the main level, as shown in Figure 9. If vertical adjustment is necessary, first loosen the probe setscrew. Then raise or lower the probe within its mandrel as necessary, and then retighten the probe setscrew gently (overtightening will crack or distort the thin plastic wall of the mandrel). Recheck the probe position.
4. The bottom of the stir/freeze wire should be even with the small step, as shown in Figure 9. As necessary, remove the head cover, loosen the stir/freeze wire setscrew(s) and reset the stir/freeze wire. Retighten the stir/freeze wire setscrew(s). Then bend the wire, if

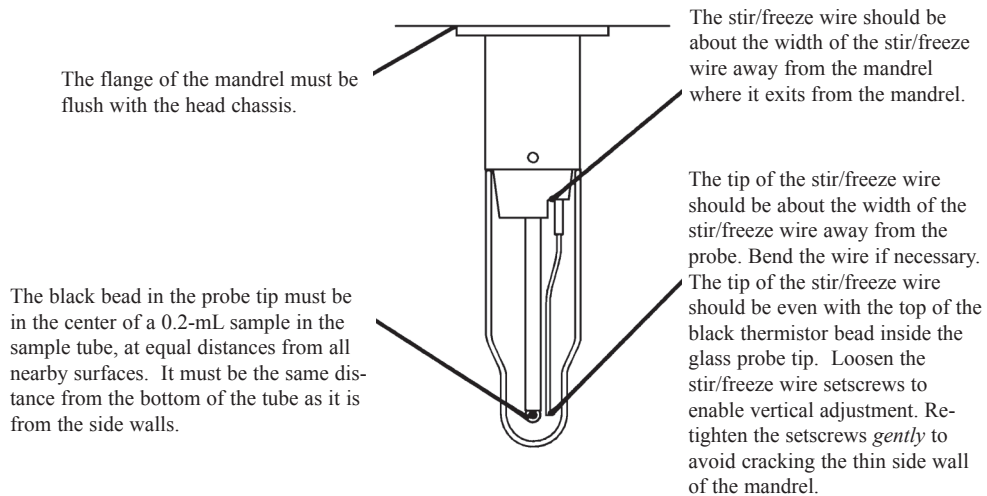

Figure 10: Mandrel, Probe and Stir/Freeze Wire Adjustment

necessary, so that the lower portion is parallel to the sample probe and spaced about .04 inches (1 mm) away from the sample probe.

5. After any probe or stir/freeze wire position adjustment, check and adjust the stir/freeze amplitude, as necessary, as recommended in Chapter 5, “Stir/Freeze Amplitude Adjustment”.
6. After making any probe and/or stir/freeze wire adjustments, check the instrument calibration and recalibrate as necessary.

Alternate method of probe and stir/freeze wire alignment using a sample tube containing 0.2-mL of water:

1. Pipette a 0.2-mL sample of H₂O or any of the standards into a sample tube. Then hold the tube up on the mandrel in the position shown in Figure 10. Note in which direction the tip of the probe must be moved (if any) to perfectly center its black sensor bead in the sample volume. Remove the sample tube.
2. If vertical adjustment of the probe tip is necessary to center the black bead in the 0.2-mL sample volume, loosen the probe setscrew (Figure 8, Item 6), then manually raise or lower the probe within the mandrel. Retighten the setscrew gently (overtightening will crack or distort the thin plastic wall of the mandrel). Recheck as described in step 1 above.
3. If horizontal adjustment is necessary to center the black bead in the sample volume, bend the metal probe stem gently in the required direction by hand. Recheck as described in step 1, above.
4. Check and adjust the stir/freeze wire position according to the recommendations in Figure 10.
5. After any stir/freeze wire position adjustment, check and adjust the stir/freeze amplitude, as necessary, as recommended in the next section “Stir/Freeze Amplitude Adjustment.”

Stir/freeze amplitude adjustment

The stir and freeze vibration amplitudes are affected by the probe, stir/freeze wire and mandrel positions. If the one-second freeze pulse is not strong enough to freeze samples reliably, visually check the freeze and stir vibration amplitudes as follows:

1. Make sure the Supervisor/Operator keyswitch is in the **Supervisor** position while using the **TEST** and **SETUP** menus (see Figure 6 and Chapter 2, “Supervisor/Operator Keyswitch”).
2. Press the **TEST** key. The display will change to “**Select Test Item**”.
3. At “**Select Test Item**”, press the **START** key. The display will change to “**Test Menu #: 0**”.
4. At “**Select Menu #: 0**”, press the **3** key; then press **ENTER**. The display will change to “**Stir/Freeze Test**”.
5. At “**Stir/Freeze Test**”, press the **START** key. The display will change to “[**stir**] [**freeze**]”.
6. At “[**stir**] [**freeze**]”, a freeze pulse will occur each time the > key is pressed. Watch the tip of the stir/freeze wire and press >. If properly adjusted, as recommended in Chapter 2, “Set Buzz Amplitude”, the stir/freeze wire should produce a loud “buzz”, vibrate principally fore and aft, and never strike the probe.

Look from the side of the instrument as you press > again; the freeze-pulse vibration blur at the very tip of the stir/freeze wire should span at least 1/2” or 13 mm for one second, then cease.

If the freeze vibration is not enough, first remove the head cover by removing the top screws and pulling straight up and make sure that there are absolutely no metal chips between the clapper and the coil armature. Even a single iron chip will greatly reduce the freeze amplitude and must be carefully wiped out of the magnetic gap. Then recheck the stir/freeze amplitude.

If the freeze vibration is still not enough, use either or both of the following adjustments:

1. Adjust the freeze “buzz” amplitude (default = 223; range = 150-255) as described in Chapter 2, “Changing Operating Settings: #14 Set ‘Buzz’ Amplitude”. In general, increasing this setting will increase the freeze vibration. However, caution should be used since too high a value may cause the clapper to become trapped by the electromagnetic coil.
2. Adjust the clapper spacing. Refer to Figure 8. Bend the yoke (Item 1) to locate the clapper (Item 3) closer to or further away from the coil (Item 2), whichever is found to increase the stir/freeze wire tip vibration.

Changing the coil-to-clapper spacing probably will adversely affect the stir/freeze wire tip location; after bending the yoke, realign the stir/freeze wire according to the recommendations in the “Mandrel, Probe, and Stir/Freeze Adjustment” section.

Check the freeze vibration amplitudes as instructed in steps 1 through 6 of this section. Optimum spacing between the coil and clapper should provide at least 1/2” or 13 mm of tip vibration.

Reinstall the operating head cover. Do one last freeze test with the operating head cover reinstalled; the freeze pulse characteristics are slightly different with it in place.

If the freeze vibration is still not enough, do not proceed further without obtaining Hot-Line® service as recommended in Chapter 5, “Obtaining Service”.

If you succeed in obtaining enough freeze vibration, the stir vibration amplitude must be readjusted as follows:

1. Press the **SETUP** key. If the Supervisor/operator keyswitch is in the **Supervisor** position, the display will change to “**Select Setup Item**”.

2. At “**Select Setup Item**”, press the **START** key. The display will change to “**Setup Menu #: 0**”.
3. At “**Setup Menu #: 0**”, press the **4** key, then press **ENTER**. The display will change to “**Set Stir Amplitude**”.
4. At “**Set Stir Amplitude**”, press the **START** key. The display will change to “**Amplitude = xxx**”, with “**xxx**” being some two- or three-digit number around 98.

Looking from the side of the instrument, you should be able to see a stir vibration blur at the tip of the stir/freeze wire. For 0.2-mL to 0.25-mL osmometer operation, the stir vibration blur at the very tip of the stir/freeze wire should be between 3/32” and 1/8” or 2 and 3 mm. Stirring is necessary to minimize temperature gradients in viscous samples but more than 1/8” or 3 mm can cause poor repeatability or frothing which may make it impossible to reliably determine the freezing point.

If the stir vibration amplitude is not correct, press > to increase the stir amplitude and the “**xx**” value or press < to decrease the stir amplitude and the “**xx**” value. Continue to increase or decrease the “**xx**” value as necessary, until the stir vibration blur at the very tip of the stir/freeze wire is between 1/32” and 1/8” or between 2 and 3 mm.

As this adjustment is completed, you may wish to hold a sample tube containing a 0.2-mL sample of either an NaCl standard or H₂O up in position on the probe and stir/freeze wire to make sure that froth is not produced.

When the stir amplitude is correct, you may wish to record the stir-amplitude “**xx**” value in the Service Log for reference. Press **ENTER** to store the new setting. The display will change to “**Set Stir Amplitude**”.

At “**Set Stir Amplitude**”, press the **STOP** key to exit the **SETUP** program (or > or < to step to another **SETUP** item).

When **STOP** is pressed, the display will change to “**Osmometer Ready**” and the 3250 is ready for freezing point tests.

IMPORTANT  After completing any probe and/or stir/freeze wire adjustments, check the instrument calibration and recalibrate as necessary.

Appendix A

Troubleshooting Table



Make sure that the instrument is unplugged before removing the instrument cover!

Problem/Message	Explanation
Abrupt loss of power 	If you lose power to your instrument, we recommend that you check that your outlet is providing the correct amount of power. Check that your cord is firmly plugged into both the instrument and the outlet. Visually inspect the fuses, and change as necessary.
“A/D Init Failure” “A/D High Filter Error” “A/D Low Filter Error” “A/D Cal Mode Error”	Error is self-correcting. If the error persists, contact Advanced Instruments for Hot-Line Service.
“Baudrate Error”	Reset baudrate. If the error persists, contact Advanced Instruments for Hot-Line Service.
“Block Probe Failure”	If you see this message, check the probe wiring and then try restarting your instrument. If the problem persists, contact Advanced Instruments for Hot-Line Service.
“Block Probe Open?”	If you see this message, first try restarting your instrument. Make sure the block probe is plugged into the main board. If the problem persists, contact Advanced Instruments for Hot-Line Service.

“Buzz Point Default Set”	If you see this message, the value stored in memory for the range at which the instrument is set was invalid. The default value has been restored. Verify your desired setting and check your calibration. If the problem persists, contact Advanced Instruments for Hot-Line Service.
“Calibration out of Range; Repeat”	If you see this message, verify that your operator technique is correct. Then, recalibrate. If the problem persists, contact Advanced Instruments for Hot-Line Service.
“Cooling System Error”	If you receive this message, check to make sure that the thermoelectric is plugged in, check the thermoelectric LED on the application PCB, then try restarting your instrument. Second, check that your instrument's cooling chamber contains enough heat transfer fluid. If the problem persists, contact Advanced Instruments for Hot-Line Service.
“Count Error: Parameter RAM”	Turn unit off and on. Custom settings and probe bin numbers may need to be reset. If the error persists, contact Advanced Instruments for Hot-Line Service.
EPROM Failure	This message indicates a memory error with your FLASH memory. Try restarting your instrument, and ignore if it does not reoccur.
“Error Reading Barcode”	Check to see if barcode scanner is damaged. Make sure that the barcode is no longer than 13 characters. Cancel barcode and repeat reading.

<p>“ESC TRAP”</p>	<p>Turn unit off and on. If the error message does not persist and no other error message is displayed, ignore this message. If the error persists, contact Advanced Instruments for Hot-Line Service.</p>
<p>“Event Record Lost”</p>	<p>This message indicates that the event record stored in memory has been corrupted. Try restarting your instrument. If this does not solve your problem, contact Advanced Instruments for Hot-Line Service.</p>
<p>“Fan System Failure”</p>	<p>Check to make sure that the fan is plugged in, and that the fan isn’t blocked. Check the fan driver LED on the application board. Try restarting your instrument. If this does not solve your problem, contact Advanced Instruments for Hot-Line Service.</p>
<p>“FPE_INTFLOW” “FPE_INTDIV0” “FPE_INVALID” “FPE_ZERODIVIDE” “FPE_OVERFLOW” “FPE_UNDERFLOW” “FPE_INEXACT” “FPE_STACKFAULT” “FPE_EXPLICITGEN” “FPE_UNDEFINED”</p>	<p>Turn unit off and on. If the error message does not persist and no other error message is displayed, ignore this message. If the error persists, contact Advanced Instruments for Hot-Line Service.</p>
<p>“Head Not Down”</p>	<p>This error indicates that the sensor at the head down position was not tripped. Clear any blockage and try restarting your instrument. If this does not solve your problem, contact Advanced Instruments for Hot-Line Service.</p>

“Head Not Up”	This error indicates that the sensor at the head up position was not tripped. Clear any blockage and try restarting your instrument. If this does not solve your problem, contact Advanced Instruments for Hot-Line Service.
“Insufficient Data”	This message indicates that not enough valid test results exist in memory for calculating the requested statistics.
Low Battery	The lithium battery contained inside the NVRAM memory is too low to maintain stored information, calibration, and system settings. The instrument will function normally as long as the main power remains on. Contact Advanced Instruments for Hot-Line Service.
Low Fluid Level in Freezing Chamber	The heat transfer fluid pump may be malfunctioning, or there may be a leak or obstruction in the fluid system. Run the Head Up/Down Test while observing the priming of the heat transfer fluid pump and the flow of fluid into and out of the freezing chamber. If leakage or an obstruction is suspected, contact Advanced Instruments for Hot-Line Service.
“Memory Allocation Error”	Turn unit off and on. If the error message does not persist and no other message is displayed, ignore this message. If the error persists, contact Advanced Instruments for Hot-Line Service.
“No Parameters in RAM”	Error is self-correcting. This will restore default settings. Custom settings and probe bin numbers will need to be reset. If the error persists, contact Advanced Instruments for Hot-Line Service.

<p>“No Plateau, Repeat Test”</p>	<p>Your instrument was unable to detect a freezing plateau, and was therefore unable to give a result. Check your technique and try again. If the message persists, obtain Hot-Line Service.</p>
<p>No response when the START or TEST key is pressed.</p>	<p>Try restarting your instrument. If this does not solve your problem, Contact Advanced Instruments for Hot-Line Service.</p>
<p>Out of Range</p>	<p>This message will appear if the plateau value exceeds the upper limit of 4000 mOsm. It will also appear if the buzz point setting limits are exceeded.</p>
<p>“Parameter RAM Failed or New Software Version”</p>	<p>This informative message tells you that a new software version has been installed since you last powered the instrument or that the information stored in parameter RAM has been corrupted. The instrument will reload factory defaults.</p>
<p>Printer fails to print</p>	<p>Make sure there is paper in the printer. If there is not, install paper per the instructions in Chapter 1, Installation and Setup. If there is paper in the printer, make sure that the printer cover is completely and securely closed.</p>
<p>Printer advances paper and appears to be printing, but the paper is blank.</p>	<p>Check to make sure the paper roll is properly installed per the instructions in Chapter 1, Installation and Setup. The paper must be feeding from the bottom of the roll, as shown in Figure 2.</p>
<p>“RAM Failure”</p>	<p>This message indicates a memory error with the system RAM. Try restarting your instrument and ignore if it does not reoccur. Your instrument may load factory defaults.</p>

“Recalibration Needed”	This message indicates that you need to recalibrate your instrument. Recalibrate closely following the instructions in Chapter 4. If the error message repeats, obtain Hot-Line Service.
“Reset Probe Config.”	Most likely, this message indicates that you should reset your block and sample probe bin numbers as described in Chapter 2. If this does not solve the problem, contact Advanced Instruments for Hot-Line Service.
“Result Over Range, Try Higher Setting”	This message indicates the final result is too high for the low range setting. Select high range and try again.
“Result Under Range, Try Lower Setting”	This message indicates the final result is too low for the high range setting. Select low range and try again.
Results not repeatable (too scattered)	If your results are not repeatable, first check that your operator technique is sound. Second, use the A/D test to ensure that your sample probe is working correctly. If you have questions or if this does not isolate the problem, please call Hot-Line Service for assistance.
“Sample Did Not Freeze...”	Test another aliquot of that sample in a clean sample tube. Try testing samples known to be within the range of the instrument.
“Sample Freeze Error...”	This message can be displayed for a number of reasons. Check your technique and the condition of your sampler. If neither of these is the source of the problem, you should check your sample and block probe numbers. If this does not solve your problem, contact Advanced Instruments for Hot-Line Service.

<p>“Sample Pre-freeze...”</p>	<p>Test another aliquot of that sample in a clean sample tube. Check/correct the probe bin numbers. Correct the stir/freeze wire alignment and adjustment as necessary. Try to minimize the effects of materials that tend to cause premature crystallization. Make sure samples contain no bubbles or froth before testing. Decrease the sample stir amplitude, if necessary, to avoid generating bubbles before the freeze buzz occurs. If this does not solve your problem, you should check the probe bin number and obtain service if necessary.</p>
<p>“Sample Probe Failure”</p>	<p>Switch the instrument off, then on. Check the sample probe by running the A/D tests. If the error message does not persist and other error messages are not displayed, ignore this message. Otherwise, contact Advanced Instruments for Hot-Line Service.</p>
<p>“Sample Probe Open?”</p>	<p>Switch the instrument off, then on. Make sure the sample probe is plugged into the main board. Check the sample probe by running the A/D tests. If the error message does not persist and other error messages are not displayed, ignore this message. Otherwise, contact Advanced Instruments for Hot-Line Service.</p>
<p>“Standards Reversed? Repeat Calibration”</p>	<p>This message will appear during the calibration procedure if the instrument detects that the low and high calibration standards may have been mixed up and were entered in the wrong order. Retry the calibration, being sure that the standards are correct.</p>



“Stir System Failure”	This error message indicates a problem with your stir/freeze wire system. Try restarting your instrument. If this does not solve your problem, contact Advanced Instruments for Hot-Line Service.
“Supervisor Key Needed...”	This feature or action has been locked out by use of the supervisor/operator keyswitch.
“System Error: Communications”	This error message indicates a system error with the communications ports. Try restarting your instrument. If this does not solve your problem, contact Advanced Instruments for Hot-Line Service.
“Test Time-out Error”	This message indicates that your instrument was unable to complete the test in the allotted time. Be sure that your operator technique is sound and retry the test. If the problem persists, check your block probe number. If you need more assistance, contact Advanced Instruments for Hot-Line Service.
“Thermoelectrics System Failure”	This error message indicates a problem with your thermoelectrics. Check the thermoelectric LED on your application PCB. Try restarting your instrument. If this does not solve your problem, contact Advanced Instruments for Hot-Line Service.
“Unknown Error”	This error message indicates a software event has occurred internally, which has no definition. Try restarting your instrument and ignore if it does not reoccur.

Appendix B

Product Specifications

Electrical <i>Power Requirement:</i> <i>Fuses (2):</i> <i>Power Consumption:</i> <i>Memory Backup:</i>	100 to 250 VAC (50/60 Hz) 250V time delay (Type T): 2-Amp 95 Watts Integral lithium cell; 10-year life (typical); (not user-replaceable)
Sample Volume:	0.20 to 0.25 mL
Sample Capacity:	Single sample
Readout:	20-character vacuum fluorescent display
Units:	mOsm/kg H ₂ O
Ranges <i>Low:</i> <i>High:</i>	0 to 2000 mOsm/kg H ₂ O 1400 to 4000 mOsm/kg H ₂ O
Resolution:	1 mOsm/kg H ₂ O
Communications:	On-board printer, DTE EIA-232/V.24 (RS-232) serial port and optional barcode scanner
Performance at Reference Conditions¹	
Linearity:	Less than 0.5% from a straight line
Repeatability <i>0 to 400 mOsm:</i> <i>400 to 4000 mOsm:</i>	Std. Deviation ≤ 2 mOsm/kg H ₂ O Std. Deviation ≤ 0.5% of value mOsm/kg H ₂ O
Drift:	Less than 1 mOsm/kg H ₂ O per month
Performance Over Operating Conditions	
Temperature Effects:	Less than 1 mOsm/kg H ₂ O for every 5°C (9°F) ambient temperature change.

¹Reference Conditions: 20°C to 25°C (68°F to 77°F); 40% to 60% Relative Humidity; tolerances of reference or calibration solutions excluded.

Operating Conditions	<p>Temperature: 18°C to 35°C (64°F to 95°F)</p> <p>Humidity: 5 to 80% relative humidity (non-condensing)</p> <p>Storage Temp.: -40°C to +45°C (-40°F to +113°F)</p> <p>Start-up Time: Immediately from stand-by; under 5 minutes from power-on</p> <p>Test Time: Approximately 2 minutes per sample in low range; approximately 3 minutes in high range</p> <p>Sound Level: Measured at operator's position < 45 dB(A) Typ. ≈ 86 dB(A) max. (2 sec.)</p>															
Dimensions	<table> <thead> <tr> <th></th> <th>inches</th> <th>centimeters</th> </tr> </thead> <tbody> <tr> <td><i>Width:</i></td> <td>13.0</td> <td>33.0</td> </tr> <tr> <td><i>Depth:</i></td> <td>18.0</td> <td>45.7</td> </tr> <tr> <td><i>Height:</i></td> <td>12.0</td> <td>30.5</td> </tr> <tr> <td><i>with Head Up:</i></td> <td>16.0</td> <td>40.6</td> </tr> </tbody> </table>		inches	centimeters	<i>Width:</i>	13.0	33.0	<i>Depth:</i>	18.0	45.7	<i>Height:</i>	12.0	30.5	<i>with Head Up:</i>	16.0	40.6
	inches	centimeters														
<i>Width:</i>	13.0	33.0														
<i>Depth:</i>	18.0	45.7														
<i>Height:</i>	12.0	30.5														
<i>with Head Up:</i>	16.0	40.6														
Weight	<table> <thead> <tr> <th></th> <th>pounds</th> <th>kilograms</th> </tr> </thead> <tbody> <tr> <td><i>Net:</i></td> <td>23.0</td> <td>10.4</td> </tr> <tr> <td><i>Shipping:</i></td> <td>34.0</td> <td>15.4</td> </tr> </tbody> </table>		pounds	kilograms	<i>Net:</i>	23.0	10.4	<i>Shipping:</i>	34.0	15.4						
	pounds	kilograms														
<i>Net:</i>	23.0	10.4														
<i>Shipping:</i>	34.0	15.4														
Warranty:	One-year limited warranty on workmanship and all parts except glass, plastic, and parts warranted by their makers															
Certification:	<div style="display: flex; align-items: center; justify-content: center;">    </div> <p>Intertek 98214</p> <p>Refer to Regulatory Notices (Appendix C) for applicable standards</p>															
<i>Installation Class:</i>	I															
<i>Over-Voltage Category:</i>	II															
<i>Pollution Degree:</i>	2															
<i>Moisture Protection:</i>	IPX0 (ordinary)															

Appendix C

Regulatory Notices

- This product has been designed and manufactured in accordance with U.S., Canadian, and European regulatory requirements as outlined below. Modifications made to this product that are not expressly approved in writing by the manufacturer will void the user's authority to operate this product, previously issued factory approvals, and the user's rights under the warranty.
- The distributor or dealer may have applied additional local, national, or international approvals to this product. Consult the distributor or dealer for more information and documentation.
- Connections to this product must be made with shielded cables. Use of non-shielded cables may violate RFI/EMI limits.

Symbol Conventions



This symbol indicates conformity to relevant European directives.



This symbol indicates the product was tested to conform to relevant Canadian and U.S. safety standards by Intertek Testing Services NA, Inc. The ETL mark is approved in the United States as a Nationally Recognized Testing Lab (NRTL) by OSHA, and in Canada by the Standards Council of Canada.



In Vitro Diagnostic Medical Device complying with EU Directive 98/79/EC.

Regulatory approval type	Description
U.S. Safety	This product has been listed by ETL testing laboratories as being in compliance with the requirements of UL 61010-1, 2nd Edition, "Electrical Equipment for Laboratory Use; Part 1: General Requirements". The "US" in the lower right of the ETL mark demonstrates this listing.
Canadian Safety	This product has been listed by ETL testing laboratories as being in compliance with the requirements of CAN/CSA C22.2 No. 61010-1, "Safety Requirements for Electrical Equipment for Measurement, Control and Laboratory Use - Part 1: General Requirements"; Including Amendment Two. The "C" in the lower left of the ETL mark demonstrates this listing.
CE Declaration of Conformity - EMC	<p>This product meets the intent of Directive 2004/108/EC for Electromagnetic Compatibility. Compliance was demonstrated using the following standards, as listed in the Official Journal of the European Communities: Consult the Declaration of Conformance certificate shipped with the product for the latest update.</p> <ul style="list-style-type: none"> • EN 61326-1:2006 & EN 55011:1998, Group 1, Class B, "Electrical Equipment for Measurement, Control, and Laboratory Use".
<p>CE Declaration of Conformity - Low Voltage</p> <p>(continued)</p>	<p>This product meets the intent of Directive 2006/95/EC, the Low Voltage Directive. Compliance was demonstrated using the following standards as listed in the Official Journal of the European Communities: Consult the Declaration of Conformance certificate shipped with the product (if required) for the latest update.</p> <ul style="list-style-type: none"> • EN 61010-1:2001, "Safety Requirements for Electrical Equipment for Measurement, Control and Laboratory Use - Part 1: General Requirements".

Regulatory approval type	Description						
(continued)	<ul style="list-style-type: none"> • EN 61010-2-101: 2002, "Safety Requirements for Electrical Equipment for Measurement, Control and Laboratory Use - Part 2-101: Particular Requirements for In Vitro Diagnostic (IVD) Medical Equipment". 						
CB Report CB Certificate	A CB report and certificate have been issued for this product. The standard used was IEC 61010-1, 2nd Edition.						
U.S. FDA Listing	<p>The osmometer, along with the calibrators and controls manufactured by Advanced Instruments, are listed with a U.S. Department of Health and Human Services, Food and Drug Administration, as:</p> <table border="0" data-bbox="641 761 928 845"> <tr> <td>Osmometer</td> <td>Class 1</td> </tr> <tr> <td>Calibrators</td> <td>Class 2</td> </tr> <tr> <td>Controls</td> <td>Class 1</td> </tr> </table>	Osmometer	Class 1	Calibrators	Class 2	Controls	Class 1
Osmometer	Class 1						
Calibrators	Class 2						
Controls	Class 1						
Health Canada License	<p>The osmometer, along with the calibrators and controls manufactured by Advanced Instruments, are licensed with Health Canada, Therapeutic Products Directorate, Medical Devices Bureau, as:</p> <table border="0" data-bbox="641 1004 928 1088"> <tr> <td>Osmometer</td> <td>Class 2</td> </tr> <tr> <td>Calibrators</td> <td>Class 2</td> </tr> <tr> <td>Controls</td> <td>Class 2</td> </tr> </table>	Osmometer	Class 2	Calibrators	Class 2	Controls	Class 2
Osmometer	Class 2						
Calibrators	Class 2						
Controls	Class 2						
EC Declaration of Conformity - IVD	This product meets the intent of Directive 98/79/EC for In Vitro Diagnostic Medical Devices. Consult the Declaration of Conformance certificate shipped with the product (if required) for the latest update.						
FCC - Part 15, Subpart B, Class B	This device complies with Part 15 of the FCC Rules. Operation is subject to the following two conditions: (1) this device may not cause harmful interference, and (2) this device must accept any interference received, including interference that may cause undesired operation.						

Regulatory approval type	Description
Canadian ICES-003	This Class B digital apparatus complies with Canadian ICES-003. <i>Cet appareil numérique de la classe B est conforme à la norme NMB-003 du Canada.</i>
EC Declaration of Conformity - WEEE	This product meets the intent of Directive 2002/96/EC as amended by 2003/108/EC for Waste Electrical and Electronic Equipment (WEEE). Consult the Declaration of Conformance certificate shipped with the product (if required) for the latest update.
EC Declaration of Conformity - RoHS	This product meets the intent of Directive 2002/95/EC for “Restriction of the Use of Certain Hazardous Substances in Electrical and Electronic Equipment” as an exempt medical device per Article 2, Paragraph 1 and per Annex 1, Category 8 of Directive 2002/96/EC.

Appendix D

Warranty & Warranty Duties

LIMITED
WARRANTY
CONDITIONS

MODEL NUMBER: _____
SERIAL NUMBER: _____
INSTALLATION DATE: _____

Advanced Instruments warrants that for 12 months from date of shipment, each new product sold or manufactured is free from defects in material and workmanship under normal installation, use and service except glass, plastic and parts warranted by their makers.

Advanced Instruments agrees that such defects will be remedied or new parts furnished in exchange for any defective part delivered by the owner, transportation charges prepaid, to the factory for our examination. If, in our judgment, the part contains any such defect it will be replaced, charging only for transportation.

This warranty does not extend to any instrument subjected to negligence, accident, abuse, misuse or other improper operation, or which has been tampered with, altered or repaired by anyone other than Advanced Instruments or its authorized service representatives. Nor does this warranty extend to any consequential damages caused by defects or improper use, or secondary damage resulting from prior problems.

The above provisions do not extend the original warranty period of any instrument or part thereof which has been replaced or repaired thereunder.

Remedies made under the terms of this warranty in no case include any obligation or responsibility for transportation charges or arrangements.

All results, calibrations, effectiveness, medical diagnoses and interpretations are the responsibility of the user.

THIS WARRANTY IS IN LIEU OF ALL OTHER

WARRANTIES, REPRESENTATIONS AND CONDITIONS OF ANY KIND, EXPRESSED OR IMPLIED IN FACT OR BY LAW. IN NO EVENT SHALL ADVANCED INSTRUMENTS BE LIABLE UNDER THIS WARRANTY OR OTHERWISE IN ANY MATTER FOR ANY REMOTE OR CONSEQUENTIAL DAMAGES RESULTING FROM THE BREACH OF THIS WARRANTY OR CONDITION IMPLIED BY LAW OR OTHERWISE, OR FOR ANY DAMAGE TO THE INSTRUMENT OR ANY PART THEREOF CAUSED BY IMPROPER INSTALLATION, UNAUTHORIZED REPAIR OR ALTERATION, NEGLIGENCE, ABUSE OR MISUSE INCLUDING USE OF IMPROPER GLASSWARE OR REAGENTS, ACCIDENT, OR ACT OF GOD.

Attention is called to the user's responsibility regarding reasonable use, useful life of the instrument and immediate notification of accident outlined in the warranty duties section of the user's guide and/or service manual.

No person is authorized to assume for us any other liability in connection with the sale or service of this equipment.

Advanced Instruments reserves the right, at any time without notice, to make changes in price, color, material, specifications and models without incurring liability to modify products previously produced, and to add or discontinue models and accessories.

This warranty gives you specific legal rights, and you may also have other rights which vary from state to state.

AI1YW REV 0

By accepting and operating this instrument, the user and Advanced Instruments agree to the following responsibilities which constitute contractual warranties and conditions between the seller and the user for the maximum benefit and usefulness of the instrument.

ADVANCED INSTRUMENTS WARRANTS THAT IT:

1. Has produced equipment equal to or exceeding that of any competitive product in the same price range in standards of design, material and workmanship.

2. Knows of no defects in design or materials which may cause bodily injury.
3. Will endeavor to advise the user of changes or improvements in the instrument as they are developed, so that the user may take steps to improve the safety and performance of his equipment throughout its useful life.
4. Will replace or repair equipment according to the guarantee on the attached warranty.
5. Will cooperate closely in common defense of any accident involving this equipment, or third-party suit against the user or operating personnel, if advised immediately by the user of the occurrence of any accident.

THE USER WARRANTS THAT:

1. The instrument will be used reasonably.
2. The instrument will be regularly maintained according to this manual, including a log of all service, tests and repairs performed on the equipment, and records will be kept of all requests for repair made to Advanced Instruments where such repairs were beyond the ability of local service personnel.
3. The instrument will not be altered without written approval from Advanced Instruments.
4. Advanced Instruments will be notified immediately if any injury occurs in any association with the instrument and will be allowed prompt and thorough exami-

nation of the instrument in question.

5. Advanced Instruments will be held harmless in cases of injury arising (see definitions below):
 - a. Beyond the useful life of the equipment.
 - b. From unreasonable use.
 - c. When Advanced Instruments is not immediately notified of said injury.
 - d. From interpretation of results.

DEFINITIONS

1. "Useful life" is:
 - a. The same as the depreciation life in the Internal Revenue Service guidelines, whether or not the user actually depreciates the instrument, but not to exceed 10 years from date of delivery to the user.
 - b. Only during the time the equipment has been maintained on a regular basis as prescribed by Advanced Instruments. If the user is in an area which has no local service, Advanced Instruments may require a local service person (understood to mean the person actually performing the "hands-on" service of the equipment) to attend and pass a reasonable maintenance and repair course.
 - c. Only during the time when the user has not altered the equipment in any way without written approval from Advanced Instruments.

- d. Only during the time when the user has not loaned, leased or resold the equipment to any third party.
2. "Reasonable use" is use:
- a. According to the instructions supplied by Advanced Instruments (assuming English-reading personnel or supervision). If neither the supervisor nor the operator reads English, the user agrees to obtain accurate translations of the instrument labels, instructions, user's guides and/or manuals provided.
 - b. Under direct, on-the-job supervision of the supervisor or other professional in charge.
 - c. In which there are no known defects or uncorrected repairs.
 - d. Only for the purpose stated in the instructions provided with the instrument.
 - e. In which the equipment has been maintained according to the instructions provided.
3. "Immediate notification" is:
- a. Recognition that time is of the essence when any accident, malpractice or product liability arises which involves Advanced Instruments equipment.
 - b. Notification to Advanced Instruments immediately (the same day, if possible) in the event of injury to any person in circumstances involving Advanced Instruments equipment in which Advanced Instruments might be named as a defendant in any form of litigation.
 - c. Allowing Advanced Instruments or its representatives, immediate, full, and thorough examination of Advanced Instruments equipment, and all records pertaining to such equipment.

Notes:

Appendix E

Supplemental RS-232 Information

The DB-9 RS-232 port on your instrument conforms to the DTE EIA-232 standard and can reliably communicate over shielded cable up to 10 meters in length, depending on the baud rate you use. Almost every item of information displayed by your instrument is also transmitted over the RS-232 port, including test results, all error messages, and most display data from the diagnostic menu.

Data is transmitted asynchronously as 1 start bit, 8 data bits and 1 stop bit, with no parity. Each message transmitted from the communication port is terminated by the sequence, Carriage Return (0D Hex), Line Feed (0A Hex). Note that your instrument is only capable of outputting information. At this time, there is no protocol for talking to the instrument.

This product's serial port output is based on "ASCII" code protocols. No special codes are used to identify errors, test results, or normal operational messages. Connection to any data collection or LIMS system will require the user or a third party to write custom interface software in order to recognize and parse the text strings of interest. Advanced Instruments does not maintain a central list of text strings used in the various versions of software created, nor have we adopted any standard protocol with respect to the format of these messages. To determine the format and type(s) of text strings contained in this instrument, users should follow the instructions in this section and save the output for evaluation by the interface programmer.

At this time Advanced Instruments has not investigated any third-party software for use or recommendation for the purpose of importing data

into PC applications, such as Microsoft® Excel or a customer's LIMS system.

Sample RS-232 Setup

As a typical example of a communications program setup, the following instructions will describe the process necessary for using your instrument in conjunction with Hyperterminal for Windows® 95 or later operating systems and a null modem cable, available from Advanced Instruments, as shown in the diagram below. You can use this procedure to be sure that your instrument and cable are operating correctly.

1. Create a Hyperterminal connection using the Hyperterminal program.
2. While working within that connection, choose the Properties selection from the File menu.
3. Select the Configure button.
4. Choose the following settings for the Configure menu and click on the OK button.

Bits per second	See user's guide.
Data bits	8
Parity	None
Stop bits	1
Flow control	None

5. Select the Settings menu.
6. Chose TTY for the Emulation option.
7. Select ASCII setup.
8. Set the Sending option to Echo Typed Characters Locally.
9. Set the Receiving option to Wrap Lines that Exceed Terminal Width.

You should at this point see all instrument output in the Hyperterminal window of your computer screen.

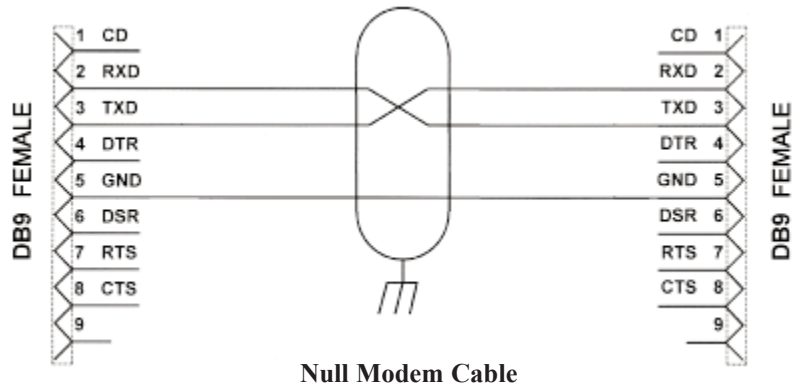















































Shield connects to metalized connector housing at both ends.















Notes:

Appendix F

Symbol Definitions

	On-Off		Functional Arrow
	Feed		Printer
	Interrupt		Enter
	Test		RS232
	Start		Bar Code
	Stop		Attention
	Record Review		Caution Hot Surface
	Setup		Dangerous Voltage
	Calibration		Lifting Hazard
	Cancel; Delete		Calibrator

 Content	 Do Not Open Top
 Control	 Handle With Care
 Negative Control	 Toxic
 Positive Control	 Use Blade To Open
 Flammable	 Do Not Re-Use
 Fragile	 For <i>In Vitro</i> Diagnostic Use
 Irritant	 European Conformity
 Keep Dry	 Temperature Limit
 Date Manufactured	 See Instructions
 Sterile	 Lot Number
 Non-Sterile	 Use By; Expiration Date
 Serial Number	 Authorized Representative
 Solution	 Part Number

	Sufficient for [x] Tests		Latex-Free
	Open Here		Diluent
	Low Fluid Level		See Instructions for Temperature Guidelines
	Keep Hands Clear		Potential Puncture Hazard
	Manufacturer		Electronic Equipment - Dispose of Properly
	Biohazard		Laser Hazard
	Cut Hazard		Static Discharge

Notes:

Appendix G

Product Disposal and Recycling

International concern about environmental pollution resulting from improper disposal of products and materials at the end of their useful life has resulted in an increase in legislation to control the methods and procedures used to handle waste electrical and electronic equipment. While the regulatory status in some regions of the world has progressed to the point where formal legislation is already in effect, many other regions are in the process of creating similar legislation or adopting that already in existence in other areas. The result in the years ahead will be more stringent control over disposal of products and recycling of their components once they are withdrawn from use.

Since regulations governing the disposal of your instrument and accessories may vary depending upon your geographic location, the following guidelines are provided to assist you in identifying the options available to you once the decision has been made to replace or dispose of this product:

- Contact the supplier who sold you the product. Whether this was Advanced Instruments itself, or one of its authorized dealers, this supplier should be knowledgeable about the national and local regulations governing disposal and recycling of products in your area. In some cases, this supplier may be legally obligated to accept the product from you and arrange for proper disposal or recycling with no further involvement on your part. Alternately, the supplier can provide you with specific instructions for actions that you can take to dispose of the product properly.

- Contact your local government agency responsible for waste collection and disposal. They can identify procedures and restrictions in effect to ensure proper disposal, and available locations where products can be sent.

- Contact Advanced Instruments Hot-Line Service:
 - 800 225-4034 (toll-free within the USA and Canada; after normal business hours, dial extension 2191)
 - +US 781-320-9000 (elsewhere)
 - 781-320-0811 (fax)

Service personnel will provide you with contact information for local disposal, or instructions for returning the product directly to Advanced Instruments.

Appendix H

Service Log

Model: 3250

Serial Number: _____

Software Revision: _____

Sample Probe Number: _____

Block Probe Number: _____

Date	Problem/Symptom	Action

Index

A

A/D tests	48
adjustments	
mandrel	58
probe	58
stir/freeze amplitude	61
stir/freeze wire	58
alignment	
mandrel	58
probe	58
stir/freeze wire	58
application board	13
assistance	29

B

back panel	15
barcode port	16
barcode scanner	17
barcode test	51
beeper test	52
buzz point	30

C

calibration	18, 37
procedure	37
notes	39
calibrators	xiii
control circuits	13

D

data capture	29
date/time	27
definitions	xviii, 80, 87
diagnostic test	8, 46
dis/enable	
I.D. #	26
beeper	27
Xon/Xoff	28
display panel	13
display/print test	51

E

electronic circuits	13
error messages	45, 65
event record	52

F

freezing chamber	13
fuse replacement	53

H

head up/down test	52
heat transfer fluid	2, 7
Hot-Line® Service	ii, 42
Hyperterminal	84

I

internal diagnostic tests 46

K

keypad 15

keypad test 52

L

language 9, 29

M

maintenance 44

maintenance of standards 34

mandrel alignment 58

measurements 33

O

operating head 12, 54

operational requirements 45

obtaining service 42

P

packing list 3

power cord connector 16

power module 5, 16

power switch 16

power up instrument 5

printer 15

printer paper 5

probe alignment 58

probe bin test 49

processor board 13

product specifications 73

product/test 29

Q

quality control 33

implementation 34

R

recall results 47

repeatability & accuracy 33

repeatability tips 19

RS-232 port 16, 32, 83

regulatory notices 75

S

sample handling 17

sample preparation 17

sample probe 54

sample test errors 24

sample test procedure 18

select buzz point 30

select range 31

serial number 29

setup menu items 23

service log 93

settings

block bin number 25

buzz amplitude 29

changing operating 24

date/time 27

sample bin number 25

serial rate 28

stir amplitude 26

standards and controls 33

statistics 46

stir/freezing test 49

stir/freezing wire alignment 58

supervisor/operator keyswitch 15
symbol
 conventions vii, 75
 definitions 87

T

testing samples 17
troubleshooting 41
 checks 45
 table 65

W

warranty 79