

August 2020

EZR Series Pressure Reducing Regulator

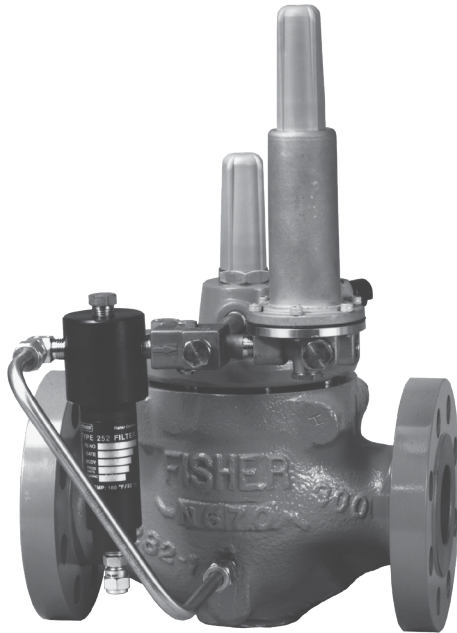

W7399

TYPE EZR REGULATOR

Introduction

The Type EZR pilot-operated, pressure reducing regulator is designed for natural gas transmission/distribution systems and industrial/commercial applications. The Type EZR provides smooth, quiet operation, tight shutoff and long life, even in dirty service. Its internally actuated metal plug eliminates disadvantages associated with boot-style regulators and the specially engineered flow path deflects debris, protecting the seat from damage and erosion. The Type EZR is used in conjunction with a 161EB or 161AY Series pilot and Type 112 restrictor or with a PRX Series pilot (with integral restrictor). The Type EZR pressure reducing regulator can be converted to a high pressure relief valve or backpressure regulator by simply changing to a relief piloting system (refer to Bulletin 71.4:EZR).

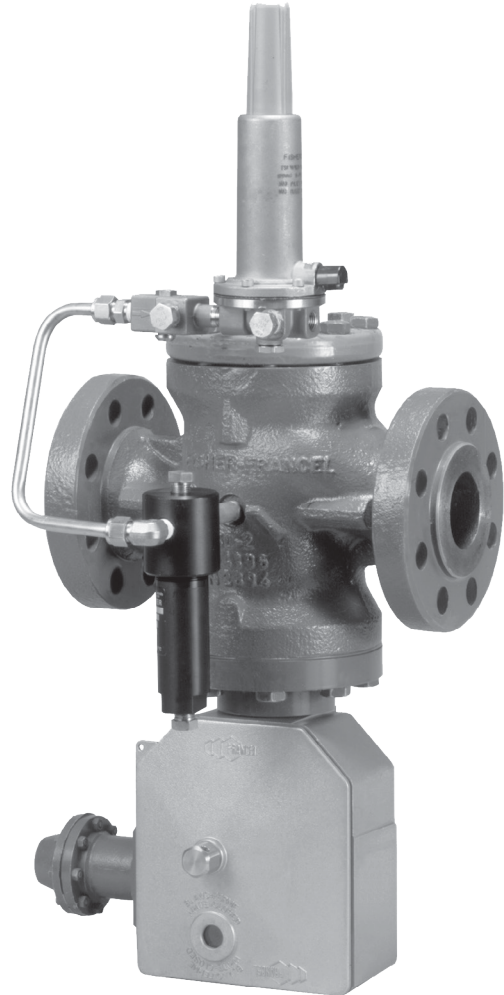

W8136

TYPE EZROX WITH INTEGRAL
SLAM-SHUT DEVICE

Figure 1. EZR Series Pressure Reducing Regulator

An optional inlet strainer prevents large particles from entering the main valve, limiting damage to internal parts. A Type 252 pilot supply filter (optional) can be added to keep pipeline debris from entering the pilot. For underpressure and/or overpressure protection, the Type EZR is available with an integral slam-shut device.

EZR Series

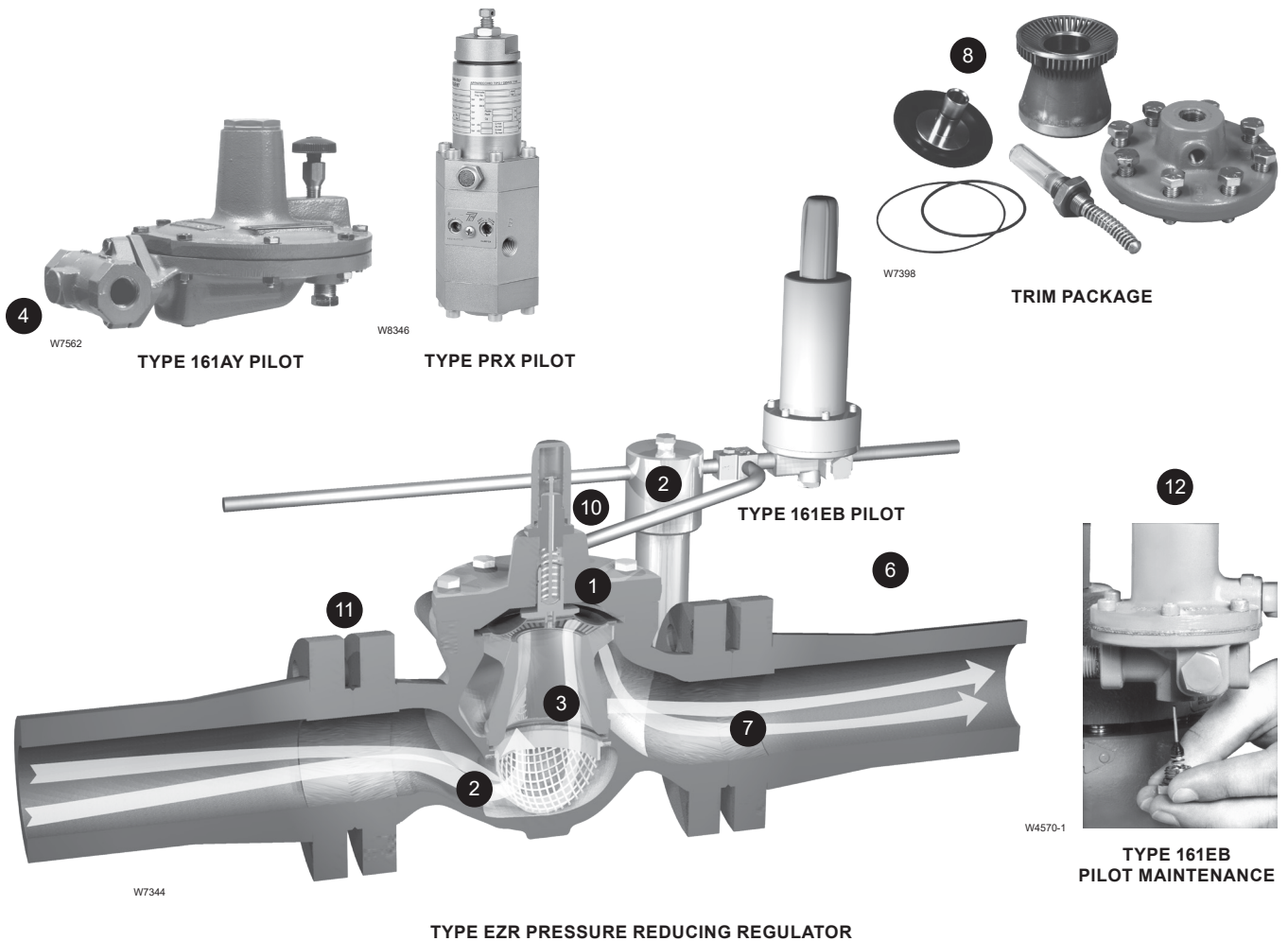

Figure 2. EZR Series Features and Benefits

Features and Benefits

- 1 Tight Shutoff**—The EZR Series uses a diaphragm and metal plug, eliminating the disadvantages of boot-style regulators. When open, the metal plug deflects particles and debris away from the diaphragm. The result is enhanced resistance to particle erosion, which provides excellent shutoff over an extended life. When closed, loading pressure and the main spring push the diaphragm onto the tapered-edged seat on the cage.
- 2 Debris Protection**—The specially engineered flow path, along with the metal plug, allows flow through the regulator without seat impingement. The addition of an optional inlet strainer prevents large particles from entering the regulator, eliminating damage to internal parts.
- 3 Quiet Operation**—The specially engineered flow path allows flow through the center of the cage and down through the cage slots—reduces operational noise, making the EZR Series an exceptionally quiet regulator.
- 4 High Accuracy**—Multiple outlet pressure ranges and narrow proportional bands offered by the 161EB Series, 161AY Series and Type PRX/120 pilots provide the EZR Series with tight, accurate control. For applications requiring tighter control, using a Type 161AYM, 161EBM, 161EBHM or PRX/120 pilot will increase the accuracy of the regulator.

- 5 **Long Life**—The robust design of the EZR Series with its metal plug and specially engineered flow path allows flow through the regulator without seat impingement. The diaphragm design eliminates the possibility of taking a “set”, a common problem with boot-style regulators. To prevent damage, the diaphragm is fully supported in both the open and closed positions. These features enable the EZR Series components to work longer with less wear and tear.
- 6 **Full Usable Capacity**—Fisher™ branded regulators are laboratory tested. 100 percent of the published flow capacity can be used with confidence.
- 7 **Thorough Laboratory Testing**—Emerson Process Management Regulator Technologies, Inc. state-of-the-art flow laboratory allows thorough testing of all new designs. Tests are conducted on Fisher branded regulators for performance features such as flow, strength, shutoff, material compatibility and noise.
- 8 **Easy In-Line Maintenance**—Top-entry design reduces maintenance time. Trim parts can be inspected, cleaned and replaced without removing the body from the pipeline. No special alignment is required when replacing the diaphragm. The EZR Series incorporates E-body construction, making it easy to change existing E-body regulators and control valves with an EZR Series trim kit.
- 9 **O-ring Design**—The EZR Series uses elastomer O-rings instead of gaskets, reducing maintenance and assembly time.
- 10 **In-Service Travel Indicator**—The optional travel indicator responds to the precise movement of the diaphragm and plug assembly and shows the actual valve position. The travel indicator makes in-service inspection and troubleshooting easy. Also, it can be used for remote alarming and monitoring stem position when combined with the Type 4310 or 4320 wireless position monitor.
- 11 **Versatility**—The EZR Series uses the E-body, making available the standard construction materials and end connections (ASME and EN) used by other E-body regulators and control valves. The 161AY Series pilots can handle inlet pressures up to 150 psig / 10.3 bar and outlet pressure from 6 in. w.c. to 7 psig / 15 mbar to 0.48 bar. The 161EB Series pilots can handle inlet pressures up to 1500 psig / 103 bar and outlet pressures from 5 to 700 psig / 0.35 to 48.3 bar.

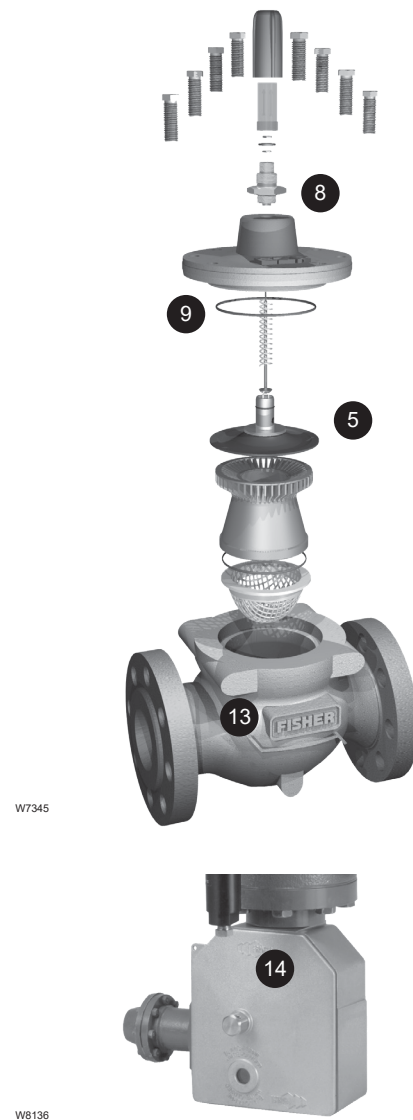

Figure 2. EZR Series Features and Benefits (continued)

The Type PRX pilots can handle inlet pressures up to 1480 psig / 102 bar and outlet pressures up to 1000 psig / 69.0 bar.

By changing to a relief piloting system (6358 Series pilots), a Type EZR pressure reducing regulator easily becomes a very effective high volume relief valve or backpressure regulator (refer to Bulletin 71.4:EZR).

EZR Series

- 12 **Easily Maintained Pilots**—The pilots are designed to allow quick and simple in-line trim inspection and parts replacement.
- 13 **Powder Paint Coating**—Fisher™ regulators are powder paint coated providing superior impact, abrasion and corrosion resistance.
- 14 **Slam-shut device**— Type EZROX with slam-shut device provides either overpressure (OPSO) or overpressure and underpressure (OPSO/UPSO) protection by completely shutting off the flow at the downstream system.

Pilot Type Descriptions

Type 161AY—Low-pressure pilot with an outlet pressure range from 6 in. w.c. to 7 psig / 15 mbar to 0.48 bar. Pilot bleeds (exhausts) downstream through the sense (control) line.

Type 161AYM—The monitor version of the Type 161AY pilot. The pilot bleed (exhaust) is isolated from the sense (control) line. This pilot is used in monitoring systems requiring an isolated pilot bleed (exhaust).

Type 161EB—High accuracy pilot with an outlet pressure range from 5 to 350 psig / 0.34 to 24.1 bar. Pilot bleeds (exhausts) downstream through the sense (control) line.

Type 161EBM—The monitor version of the Type 161EB pilot. The pilot bleed (exhaust) is isolated from the sense (control) line. This pilot is used in monitoring systems requiring an isolated pilot bleed (exhaust).

Type 161EBH—The high pressure version of the Type 161EB pilot with an outlet pressure range from 250 to 700 psig / 17.2 to 48.3 bar.

Type 161EBHM—The high pressure version of the Type 161EBM pilot with an outlet pressure range from 250 to 700 psig / 17.2 to 48.3 bar.

Type PRX/120—Outlet pressure range of 14.5 to 435 psig / 1 to 30.0 bar. The Type PRX/120 can be used as the pilot on single stage pressure reducing regulators, as the monitor pilot or as the working pilot in wide-open monitor systems or as the working pilot for monitoring and working regulators in the working monitoring systems. The Type PRX has a double diaphragm which provides increased accuracy and sensitivity, an integral restrictor adjustment to allow adjustable opening and closing speeds and a damper adjustment to allow adjustments to make for inlet pressure variability and loading pressure oscillations.

Type PRX/120-AP—Outlet pressure range of 435 to 1000 psig / 30.0 to 69.0 bar. The Type PRX/120-AP can be used as the pilot on single stage pressure reducing regulators, as the monitor pilot or as the working pilot in wide-open monitor systems or as the working pilot for monitoring and working regulators in the working monitoring systems.

Type PRX/125 (Monitor Pilot Only)—Identical to the Type PRX/120 except the restriction screw is removed. The Type PRX/125 can only be used as the monitor override pilot on working monitor applications. Always order with Type PRX-120 in working monitor applications.

Type PRX/125-AP (Monitor Pilot Only)—Identical to the Type PRX/120-AP except the restriction screw is removed. The Type PRX/125-AP can only be used as the monitor override pilot on working monitor applications. Always order with Type PRX/120-AP in working monitor applications.

Low Flow Application Considerations

When selecting pilots to use with the EZR Series:

Use the 161 Series pilots for applications where normal flow is typically 5% and greater of maximum rated flow. The accuracy and control of the 161 Series pilots can be increased using the series' monitor pilots (M).

When the potential for low flow (< 5% of maximum rated flow) for extended periods exists due to the regulator being oversized or operational constraints the Type PRX pilot is recommended.

Installation of an oversized regulator may make low flow operation difficult. The smallest Type EZR that meets the flow requirements should be selected. Reduced capacity trim reduces relief valve requirements by decreasing the maximum possible flow through the regulator but does not improve low flow performance. Additional details on how to set up the pilots for various flow rates is provided in the Type EZR Instruction Manual. If you have questions on which pilot to use for your application, contact your local Sales Office.

Optional Pilot Supply Filter

The Type 252 pilot supply filter prevents pipeline debris from entering the pilot, a primary cause of pilot clogging. The aluminum body is rated for 2150 psig / 148 bar and the stainless steel body for 2750 psig / 190 bar. Both are available in standard or extended length with a pipe plug or a drain valve. When the upstream system is free of debris, the EZR Series may be installed without a filter.

Specifications

This section lists the specifications for the EZR Series pressure reducing regulator. The set pressure range for a pilot as it comes from the factory appears on the spring case. Other information for an individual main valve appears on the nameplate.

Available Configurations

Type EZR: Pilot-operated pressure reducing regulator for low to high outlet pressure

Type EZROX: Type EZR with a Type OS2 slam-shut device for overpressure (OPSO) or overpressure and underpressure (OPSO/UPSO) protection

Main Valve Body Sizes, End Connection Styles and Structural Design Ratings⁽¹⁾⁽²⁾

See Table 1

Maximum Inlet Pressures and Pressure Drops⁽¹⁾

Main Valve: See Table 7

Pilots: See Table 3

Restrictor: 1500 psig / 103 bar

Outlet (Control) Pressure Ranges

See Table 2

Main Valve Plug Travel

NPS 1, 1-1/4 x 1, 2 x 1 / DN 25, 32 x 25, 50 x 25:
0.37 in. / 9.4 mm

NPS 2 / DN 50: 0.68 in. / 17 mm

NPS 3 / DN 80: 0.98 in. / 25 mm

NPS 4 / DN 100: 1.19 in. / 30 mm

NPS 6 / DN 150: 1.5 in. / 38 mm

NPS 8 / DN 200: 1.75 in. / 44 mm

Minimum and Maximum Differential Pressures⁽¹⁾

See Tables 4 and 8

Main Valve Flow Direction

Up through the center of the cage and down through the cage slots

Proportional Bands

See Table 2

Regulating Capacities

See Tables 13 and 14

Flow Coefficients

Main Valve: See Tables 9 and 10

Pilots: See Table 11

Restrictor: See Table 12

IEC Sizing Coefficient

See Table 7

Pressure Registration

External

Process Temperature Capabilities⁽¹⁾

See Table 6

Approximate Weights

See Table 17

Options

- Pre-piped Pilot Supply and Pilot Bleed
- Travel Indicator
- Inlet Strainer
- Type 252 Pilot Supply Filter
- Trim Package
- Relief Size-Reduction Trim
- Pilot Diaphragm for Pressure Loading

Construction Materials

EZR Series Main Valve

Body: Cast iron, WCC steel or LCC steel

Bonnet: Steel

Bonnet Bushing: Stainless steel

Cage: Stainless steel

Spring: Zinc-plated steel or Stainless steel

Top Plug: Stainless steel

Bottom Plug: Stainless steel

Inlet Strainer: Stainless steel

Strainer Replacement Shim: Stainless steel

Diaphragm: Nitrile (NBR) or Fluorocarbon (FKM)

O-rings: Nitrile (NBR) or Fluorocarbon (FKM)

Flanged Locknut: Zinc-plated steel

Backup Rings: Polytetrafluoroethylene (PTFE)

Upper Spring Seat: Stainless steel

Indicator Protector and Cover: Plastic

Indicator Stem: Stainless steel

Indicator Fitting: Stainless steel

Travel Indicator Plug: Stainless steel

Restricted Trim

E-Ring: Carbon steel

Restrictor Plate: Stainless steel

161EB Series Pilots

Body: Stainless steel

Spring Case: Stainless steel

Body Plug: Stainless steel

Control Spring: Zinc-plated steel

Valve Plug: Nitrile (NBR) or Fluorocarbon (FKM)

Adjusting Screw: Zinc-plated steel

Diaphragm: Nitrile (NBR) or Fluorocarbon (FKM)

Diaphragm Limiter: Stainless steel

O-rings: Nitrile (NBR)

161AY Series Pilots

Body: Cast iron

Spring Case and Lower Casing: Ductile iron

Stem Guide: Stainless steel

Control Spring: Zinc-plated steel

1. The pressure/temperature limits in this Bulletin and any applicable standard or code limitation should not be exceeded.

2. Ratings and end connections other than ASME standards can usually be provided; contact your local Sales Office.

EZR Series

Specifications (continued)

<p>161AY Series Pilots (continued) <i>Lever Assembly:</i> Stainless steel <i>Pusher Post:</i> Stainless steel <i>Diaphragm:</i> Nitrile (NBR) or Fluorocarbon (FKM) <i>O-rings:</i> Nitrile (NBR) or Fluorocarbon (FKM) <i>Orifice:</i> Stainless steel <i>Disk Assembly:</i> Nitrile (NBR) or Fluorocarbon (FKM)</p> <p>PRX Series Pilots <i>Body:</i> Steel <i>Trim:</i> Stainless steel <i>Elastomers:</i> Nitrile (NBR) or Fluorocarbon (FKM) <i>Disk Material:</i> Polyurethane (PU) or Fluorocarbon (FKM)</p> <p>Mounting Parts <i>Pilot Mounting Pipe Nipple:</i> Plated steel <i>Tabing and Fittings:</i> Stainless steel</p>	<p>Type 112 Restrictor <i>Body:</i> Stainless steel <i>Groove Valve:</i> Stainless steel <i>Retainer:</i> Stainless steel <i>Pipe Plug:</i> Stainless steel <i>O-rings:</i> Fluorocarbon (FKM)</p> <p>Type 252 Pilot Supply Filter <i>Body:</i> Aluminum or Stainless steel <i>Filter Cartridge:</i> Polyethylene <i>O-rings:</i> Nitrile (NBR) <i>Drain Valve or Pipe Plug:</i> Stainless steel</p> <p>Slam-Shut Device <i>Mechanism Box:</i> Aluminum alloy <i>First and Second Stage Mechanism:</i> Steel <i>Diaphragm:</i> Nitrile (NBR) <i>Bellows:</i> Stainless steel</p>
--	--

Table 1. Main Valve Body Sizes, End Connection Styles and Body Ratings

TYPE	MAIN VALVE BODY SIZE		MAIN VALVE BODY MATERIAL	END CONNECTION STYLE ⁽¹⁾	STRUCTURAL DESIGN RATING ⁽²⁾	
	NPS	DN			psig	bar
EZR	2 x 1, 2, 3, 4 and 6	50 x 25, 50, 80, 100 and 150	Cast iron	NPT 2 x 1 and 2 only	400	28.0
				CL125 FF	200	14.0
	1, 1-1/4 x 1 ⁽³⁾ , 2 x 1, 2, 3, 4, 6 x 4 ⁽⁴⁾ , 8 x 4 ⁽⁴⁾ , 6, 8 x 6 ⁽⁴⁾ and 12 x 6 ⁽⁴⁾	25, 32 x 25 ⁽³⁾ , 50 x 25, 50, 80, 100, 150 x 100 ⁽⁴⁾ , 200 x 100 ⁽⁴⁾ , 150, 200 x 150 ⁽⁴⁾ and 300 x 150 ⁽⁴⁾	WCC Steel	NPT or SWE NPS 1, 2 x 1 and 2 only / DN 25, 50 x 25 and 50 only	1500	103
				CL150 RF	290	20.0
				CL300 RF	750	52.0
				CL600 RF or BWE	1500	103
	8	200	LCC Steel	CL150 RF	290	20.0
				CL300 RF	750	52.0
CL600 RF				1500	103	
CL150 RF				290	20.0	
EZROX	1, 2 x 1, 2, 3, 4 and 6	25, 50 x 25, 50, 80, 100 and 150	WCC Steel	CL300 RF	750	52.0
				CL600 RF	1500	103
				CL150 RF	290	20.0

1. Ratings and end connections for other than ASME standard can usually be provided. Contact your local Sales Office for assistance.
2. See Tables 3, 6, 7 and 8 for diaphragm materials and additional pressure ratings.
3. Available in steel NPT only.
4. NPS 6 x 4, 8 x 4, 8 x 6, 12 x 6 / DN 150 x 100, 200 x 100, 200 x 150, 300 x 150 Types EZR and 399 bodies are not the same as the EW valve bodies and are not interchangeable.

Table 2. Outlet (Control) Pressure Ranges and Typical Proportional Bands

TYPE	OUTLET (CONTROL) PRESSURE RANGE		PROPORTIONAL BAND ⁽¹⁾⁽³⁾		PILOT CONTROL SPRING INFORMATION					
					Part Number	Color Code	Wire Diameter		Free Length	
	psig	bar	psig	bar			In.	mm	In.	mm
161AY or 161AYM	6 to 15 in. w.c.	15 to 37	1 in. w.c.	3 mbar ⁽²⁾	1B653927022	Olive drab	0.105	2.67	3.75	95.2
	0.5 to 1.2	34 to 83	1 in. w.c.	3 mbar ⁽²⁾	1B537027052	Yellow	0.114	2.90	4.31	109
	1.2 to 2.5	83 mbar to 0.17 bar	0.5	34 mbar ⁽²⁾	1B537127022	Light green	0.156	3.96	4.13	105
	2.5 to 4.5	0.17 to 0.31	0.5	34 mbar ⁽²⁾	1B537227022	Light blue	0.187	4.75	3.94	100
	4.5 to 7	0.31 to 0.48	0.5	34 mbar ⁽²⁾	1B537327052	Black	0.218	5.54	4.13	105
161EB or 161EBM	5 to 15	0.34 to 1.0	0.5	34 mbar ⁽²⁾	17B1260X012	White	0.120	3.05	3.75	95.2
	10 to 40	0.69 to 2.8	0.5	34 mbar ⁽²⁾	17B1262X012	Yellow	0.148	3.76	3.75	95.2
	30 to 75	2.1 to 5.2	0.6	41 mbar ⁽²⁾	17B1259X012	Black	0.187	4.75	4.00	102
	70 to 140	4.8 to 9.7	1.3	90 mbar ⁽²⁾	17B1261X012	Green	0.225	5.71	3.70	94.0
	130 to 200	9.0 to 13.8	1.5	0.10 ⁽²⁾	17B1263X012	Blue	0.262	6.65	3.85	97.8
	200 to 350	13.8 to 24.1	3	0.21 ⁽²⁾	17B1264X012	Red	0.294	7.47	4.22	107
161EB ⁽⁴⁾	30 to 300	2.1 to 20.7	6	0.41	15A9258X012	Green	0.243	6.17	1.88	47.7
161EBH or 161EBHM	250 to 450	17.2 to 31.0	3.5	0.24 ⁽⁵⁾	17B1263X012	Blue	0.262	6.66	3.85	97.8
	400 to 700	27.6 to 48.2	7	0.48 ⁽⁵⁾	17B1264X012	Red	0.294	7.47	4.22	107

1. Proportional band and Accuracy Class include outlet pressure drop plus hysteresis (friction), but do not include lockup.
2. Proportional band was determined with a pressure drop ranging from 50 to 150 psig / 3.5 to 10.3 bar. Approximately double the proportional band if the pressure drop is less than 50 psig / 3.5 bar.
3. With Type 112 restrictor set on 2. With Type PRX restrictor turn the restrictor screw one turn counterclockwise from fully seated.
4. Should only be used as the intermediate reduction pilot on the Type EZR worker/monitor systems.
5. Proportional band was determined with a pressure drop ranging from 100 to 300 psig / 6.9 to 20.7 bar. Approximately double the proportional band if the pressure drop is less than 100 psi / 6.9 bar.

- continued -

Table 2. Outlet (Control) Pressure Ranges and Typical Proportional Bands (continued)

TYPE	OUTLET (CONTROL) PRESSURE RANGE		ACCURACY CLASS (AC) ⁽¹⁾	PILOT CONTROL SPRING INFORMATION					
	psig	bar		Part Number	Color Code	Wire Diameter		Free Length	
						In.	mm	In.	mm
PRX/120 PRX/125	14.5 to 26	1.00 to 1.8	2.5%	M0255240X12	Yellow	0.110	2.79	2.16	54.9
	23 to 44	1.6 to 3.0	2.5%	M0255230X12	Green	0.126	3.20		
	41 to 80	2.8 to 5.5	2.5%	M0255180X12	Blue	0.138	3.50		
	73 to 123	5.0 to 8.5	2.5%	M0255220X12	Black	0.157	3.99		
	116 to 210	8.0 to 14.5	1%	M0255210X12	Silver	0.177	4.50		
	203 to 334	14.0 to 23.0	1%	M0255200X12	Gold	0.197	5.00	2.00	50.8
	319 to 435	22.0 to 30.0	1%	M0255860X12	Aluminum	0.236	5.99	2.00	50.8
PRX/120-AP PRX/125-AP	435 to 1000	30.0 to 69.0	1%	M0273790X12	Clear	0.335	8.51	3.93	99.8

1. Proportional band and Accuracy Class include outlet pressure drop plus hysteresis (friction), but do not include lockup.

Table 3. Pilot Pressure Ratings

TYPE	MAXIMUM INLET PRESSURE		MAXIMUM EMERGENCY OUTLET PRESSURE OR MAXIMUM EMERGENCY SENSE PRESSURE ⁽¹⁾		MAXIMUM BLEED (EXHAUST) PRESSURE FOR MONITOR PILOT	
	psig	bar	psig	bar	psig	bar
161AY	150	10	150	10		
161EB and 161EBH	1500	103	1200	83	----	
161AYM	150	10	150	10	150	10
161EBM and 161EBHM	1500	103	1200	83	1500	103
PRX Series	1480	102	1480	102	1480	102

1. Maximum pressure to prevent the casings from bursting during abnormal operation (leaking to atmosphere and internal parts damage might occur).

Table 4. Main Valve Minimum Differential Pressures⁽¹⁾

MAIN VALVE BODY SIZE		MAIN SPRING PART NUMBER AND COLOR	DIAPHRAGM MATERIAL	MINIMUM DIFFERENTIAL, PERCENT OF CAGE CAPACITY												
NPS	DN			For 90% Capacity						For 100% Capacity						
				100% Trim		60% Trim		30% Trim		100% Trim		60% Trim		30% Trim		
		psid	bar d	psid	bar d	psid	bar d	psid	bar d	psid	bar d	psid	bar d	psid	bar d	
1, 1-1/4 x 1	25, 32 x 25	19B2400X012, Light Blue	17E68 and 17E88		24	1.7	29	2.0	31	2.2	24	1.7	31	2.2	40	2.8
		GE12727X012, Black	17E97		35	2.5	38	2.7	42	2.9	35	2.5	39	2.7	52	3.6
		19B2401X012, Black with White Stripe ⁽³⁾	17E68 and 17E88		30	2.1	35	2.4	39	2.7	30	2.1	36	2.5	52	3.6
2 x 1	50 x 25	19B2400X012, Light Blue	17E68 and 17E88		24	1.7	29	2.0	31	2.2	24	1.7	31	2.2	40	2.8
		19B2401X012, Black with White Stripe	17E97		43	3.0	50	3.4	56	3.9	43	3.0	53	3.7	68	4.7
		GE12501X012, Red Stripe ⁽³⁾	17E68 and 17E88		43	3.0	50	3.4	56	3.9	43	3.0	53	3.7	68	4.7
2	50	19B0951X012, Yellow ⁽²⁾	17E68 and 17E88		12	0.8	15	1.0	15	1.0	12	0.8	25	1.7	20	1.4
		18B2126X012, Green	17E97		24	1.7	25	1.7	26	1.8	24	1.7	30	2.1	37	2.6
		17E68 and 17E88	17E97		18	1.2	20	1.4	22	1.5	19	1.3	26	1.8	28	1.9
3	80	18B5955X012, Red ⁽³⁾ GE05504X012, Purple ⁽³⁾	17E88 and 17E97		29	2.0	29	2.0	31	2.1	31	2.1	35	2.4	43	3.03
		T14184T0012, Yellow ⁽²⁾	17E68 and 17E88		16	1.1	19	1.3	24	1.7	23	1.6	23	1.6	29	2.0
		17E97	17E97		23	1.6	23	1.6	23	1.6	23	1.6	23	1.6	25	1.7
4, 6 x 4 and 8 x 4	100, 150 x 100 and 200 x 100	19B0781X012, Light Blue	17E68 and 17E88		21	1.5	22	1.5	28	1.9	28	1.9	28	1.9	33	2.3
		19B0782X012, Black ⁽³⁾	17E88 and 17E97		32	2.2	33	2.3	43	3.0	38	2.6	38	2.6	50	3.4
		T14184T0012, Yellow ⁽²⁾	17E68 and 17E88		10	0.7	12	0.8	14	1.0	25	1.7	25	1.7	25	1.7
6, 8 x 6 and 12 x 6	150, 200 x 150 and 300 x 150	18B8501X012, Green	17E97		16	1.1	17	1.2	21	1.5	34	2.3	34	2.3	34	2.3
		17E68 and 17E88	17E68 and 17E88		16	1.1	17	1.2	20	1.4	30	2.1	30	2.1	30	2.1
		18B8502X012, Red ⁽³⁾	17E88 and 17E97		21	1.5	24	1.7	26	1.8	40	2.8	40	2.8	40	2.8
8	200	19B0364X012, Yellow ⁽²⁾	17E97		10	0.7	11	0.8	14	1.0	12	0.8	16	1.1	16	1.1
		17E88	17E88		10	0.7	13	0.9	13	0.9	12	0.8	21	1.5	21	1.5
		19B0366X012, Green	17E97		14	1.0	22	1.5	22	1.5	19	1.3	29	2.0	29	2.0
		19B0365X012, Red ⁽³⁾	17E88 and 17E97		23	1.6	29	2.0	29	2.0	30	2.1	41	2.8	41	2.8
		GE09393X012, Yellow ⁽²⁾	17E97		16	1.1					19	1.3				
		GE09396X012, Green	17E97		20	1.4					23	1.6				
		GE09397X012, Red ⁽³⁾	17E97		26	1.8					30	2.1				

1. See Table 1 for structural design ratings, Table 3 for pilot ratings and Table 7 for maximum pressure ratings.

2. The yellow spring is only recommended for inlet pressures under 100 psig / 6.9 bar.

3. The red, black, purple, red stripe and black with white stripe springs are only recommended for applications where the maximum inlet pressure can exceed 500 psig / 35 bar.

EZR Series

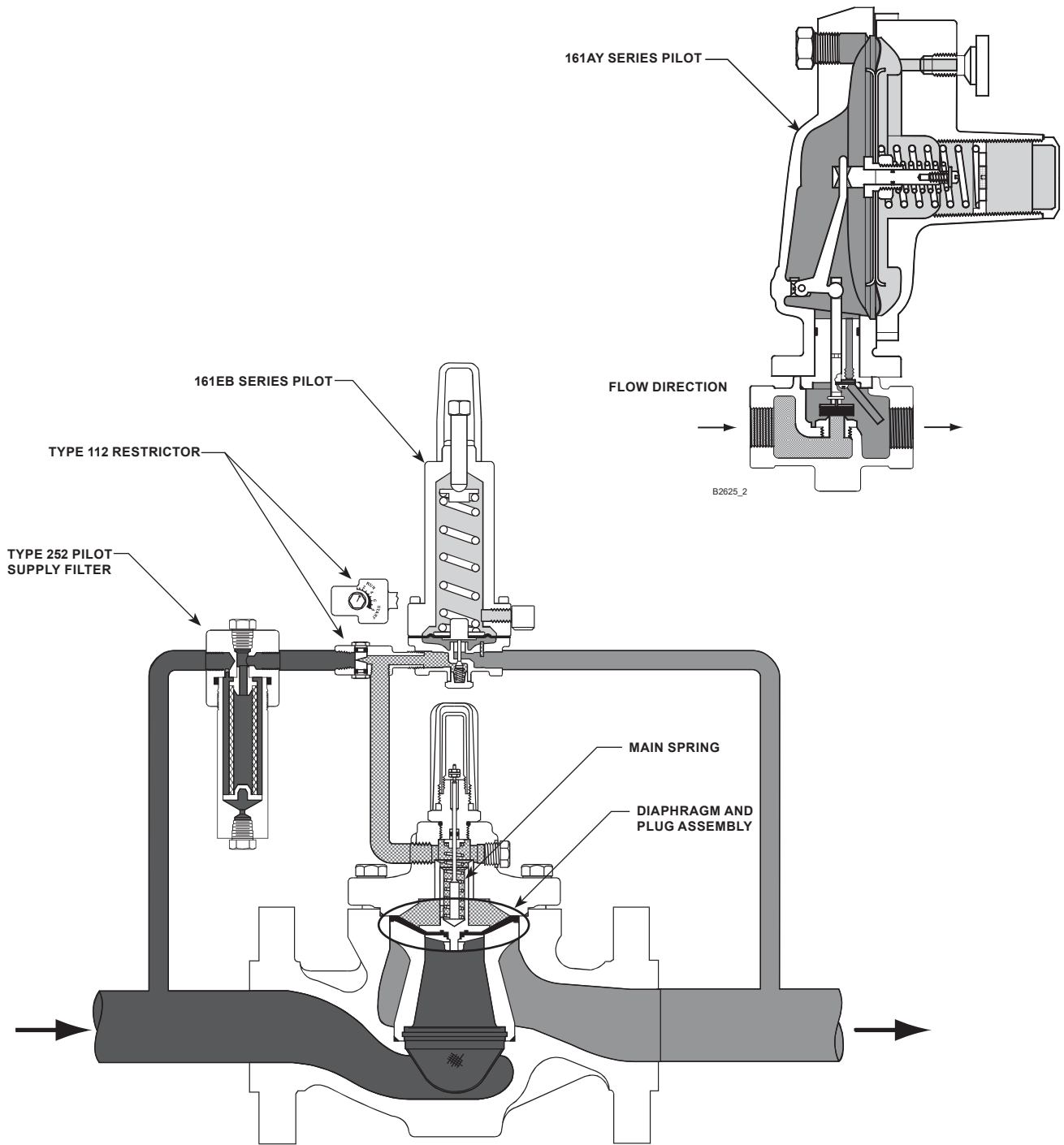

3A—TYPE EZR WITH TYPES 161EB PILOT, 112 RESTRICTOR AND 252 FILTER

W7438_07/2008

- INLET PRESSURE
- OUTLET PRESSURE
- ATMOSPHERIC PRESSURE
- LOADING PRESSURE

Figure 3. Type EZR Operational Schematic

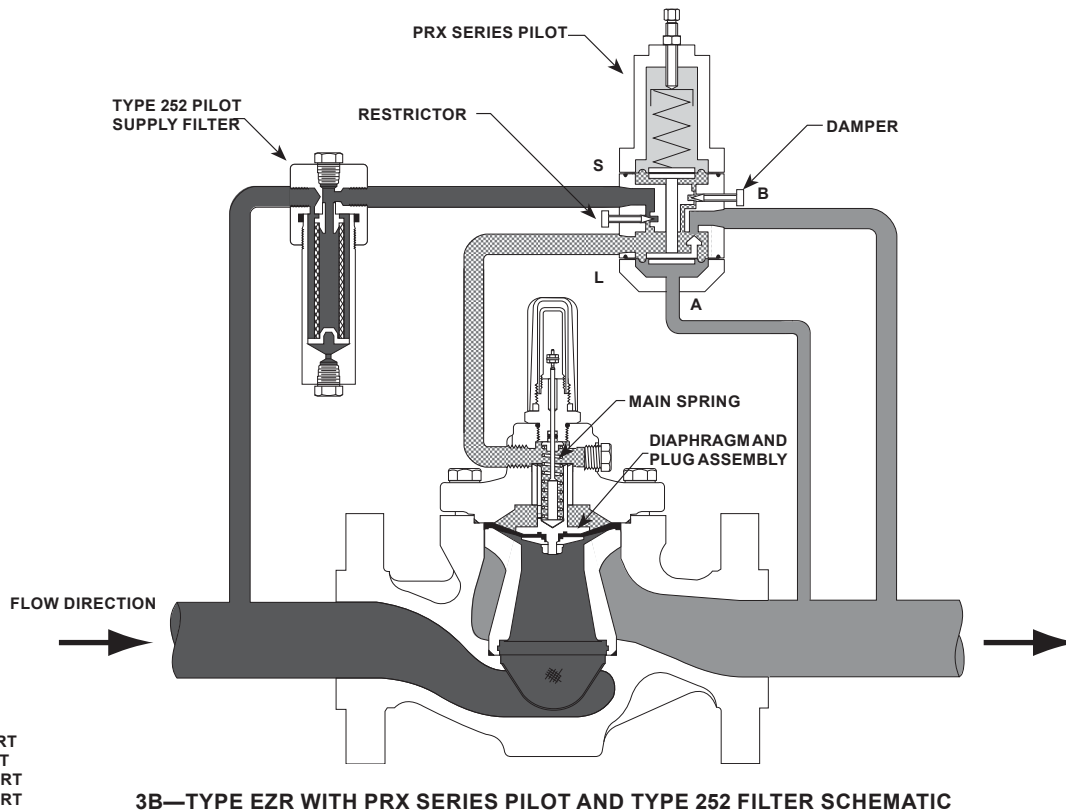

S - SUPPLY PORT
 B - BLEED PORT
 L - LOADING PORT
 A - SENSING PORT

3B—TYPE EZR WITH PRX SERIES PILOT AND TYPE 252 FILTER SCHEMATIC

E0790_09/2006

■ INLET PRESSURE
 ■ OUTLET PRESSURE
 □ ATMOSPHERIC PRESSURE
 ▨ LOADING PRESSURE

Figure 3. Type EZR Operational Schematic (continued)

Principle of Operation

As long as the outlet (control) pressure is above the outlet pressure setting, the pilot valve plug or disk remains closed (Figure 3). Force from the main spring, in addition to inlet pressure bleeding through the restrictor (integral in the PRX Series pilots), provide downward loading pressure to keep the main valve diaphragm and plug assembly tightly shutoff.

When the outlet pressure decreases below the pilot outlet pressure setting, the pilot plug or disk assembly opens. Loading pressure bleeds downstream through the pilot faster than it can be replaced through the supply line. This reduces loading pressure on top of the main valve diaphragm and plug assembly and lets the unbalanced force between inlet and loading pressure overcome the main spring force to open the Type EZR diaphragm and plug assembly.

As the outlet pressure rises toward the outlet pressure setting, it compresses the pilot diaphragm against the pilot control spring and lets the pilot valve plug or

disk close. Loading pressure begins building on the Type EZR diaphragm and plug assembly. The loading pressure, along with force from the main spring, pushes the diaphragm and plug assembly onto the tapered-edge seat, producing tight shutoff.

Installation (Figure 8)

The robust design of the Type EZR regulator allows it to be installed indoors or outdoors. When installed outdoors, the Type EZR does not require a protective housing. It is designed to withstand the elements and the powder paint coating protects it against impacts, abrasions and corrosion.

When installed indoors, no remote venting is required except on the pilot spring case. This regulator can also be installed in a pit that is subject to flooding by venting the pilot spring case above the maximum possible flood level so the pilot setting can be referenced at atmospheric pressure.

EZR Series

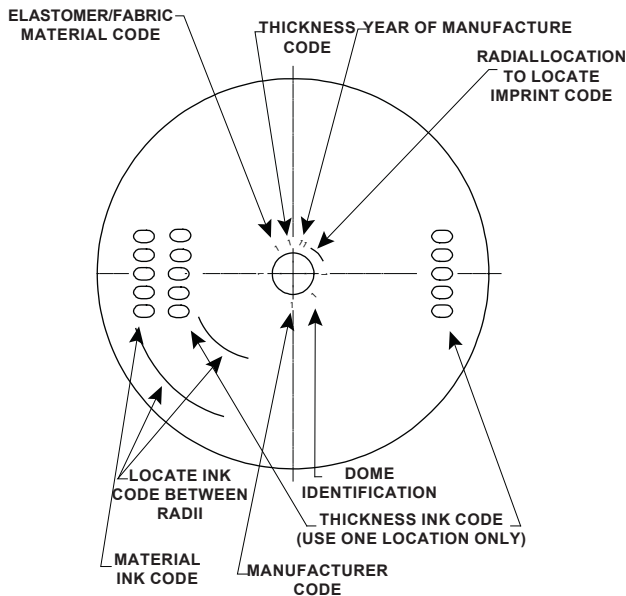

Figure 4. Diaphragm Markings

Monitoring Systems

Monitoring regulation is overpressure protection by containment, therefore, there is no relief valve to vent to the atmosphere. When the working regulator fails to control the pressure, a monitor regulator installed in series, which has been sensing the downstream and control pressure, goes into operation to maintain the downstream pressure at a slightly higher than normal pressure. During an overpressure situation, monitoring keeps the customer on line. Also, testing is relatively easy and safe. To perform a periodic test on a monitoring regulator, increase the outlet set pressure of the working regulator and watch the outlet pressure to determine if the monitoring regulator takes over at the appropriate outlet pressure.

Wide-Open Monitoring Systems (Figure 5)

There are two types of wide-open monitoring systems: upstream and downstream. The difference between upstream and downstream monitoring is that the functions of the regulators are reversed. Systems can be changed from upstream to downstream monitoring and vice-versa, by simply reversing the setpoints of the two regulators. The decision to use either an upstream or downstream monitoring system is largely a matter of personal preference or company policy.

Table 5. Diaphragm Imprint Codes

THICKNESS		MATERIAL		DIAPHRAGM MATERIAL
Imprint	Ink Code	Imprint	Ink Code	
2	130	2	17E68	17E68 - Nitrile (NBR) (low temperature)
		4	17E88	17E88 - Fluorocarbon (FKM) (high aromatic hydrocarbon content resistance)
		5	17E97	17E97 - Nitrile (NBR) (high-pressure and/or erosion resistance)

In normal operation of a wide-open configuration, the working regulator controls the system's outlet pressure. With a higher outlet pressure setting, the monitor regulator senses a pressure lower than its setpoint and tries to increase outlet pressure by going wide-open. If the working regulator fails, the monitoring regulator assumes control and holds the outlet pressure at its outlet pressure setting.

In a wide-open Type EZR monitoring system, system lockup will equal the lockup of the worker regulator on both an upstream monitor when the upstream pilot exhaust is piped to the intermediate pressure and a downstream monitor with upstream pilot exhaust piped to either intermediate pressure or outlet pressure. With these configurations, the diaphragm of the monitor regulator will change position with every load change. On an upstream monitor with the upstream pilot exhaust piped to downstream, lockup will occur at the monitor's setpoint and the diaphragm of the monitor regulator will be fully open.

Working Monitoring Regulators (Figure 6)

In a working monitoring system, the upstream regulator requires two pilots and it is always the monitoring regulator. The additional pilot permits the monitoring regulator to act as a series regulator to control an intermediate pressure during normal operation. In this way, both units are always operating and can be easily checked for proper operation. In a working monitor system, system lockup will equal the lockup of the downstream regulator.

In normal operation, the working regulator controls the outlet pressure of the system. The monitoring regulator's working pilot controls the intermediate pressure and the monitoring pilot senses the system's outlet pressure. If the working regulator fails, the monitoring pilot will sense the increase in outlet pressure and take control.

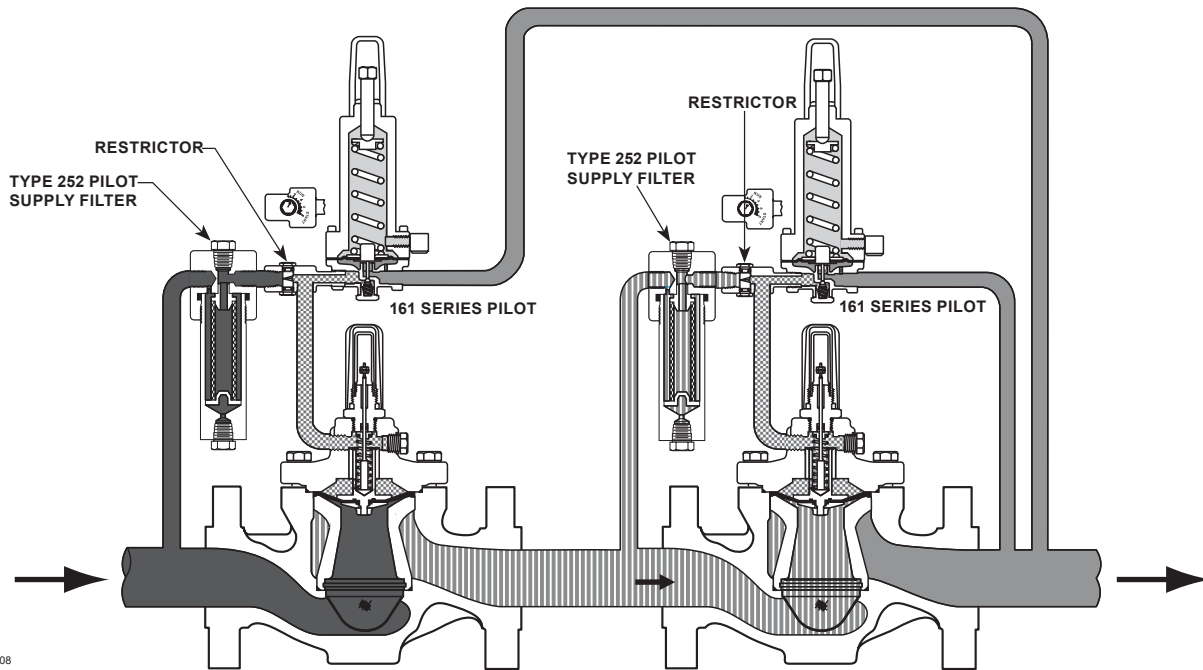

E0757_07/2008

TYPE EZR-161 WIDE-OPEN MONITOR

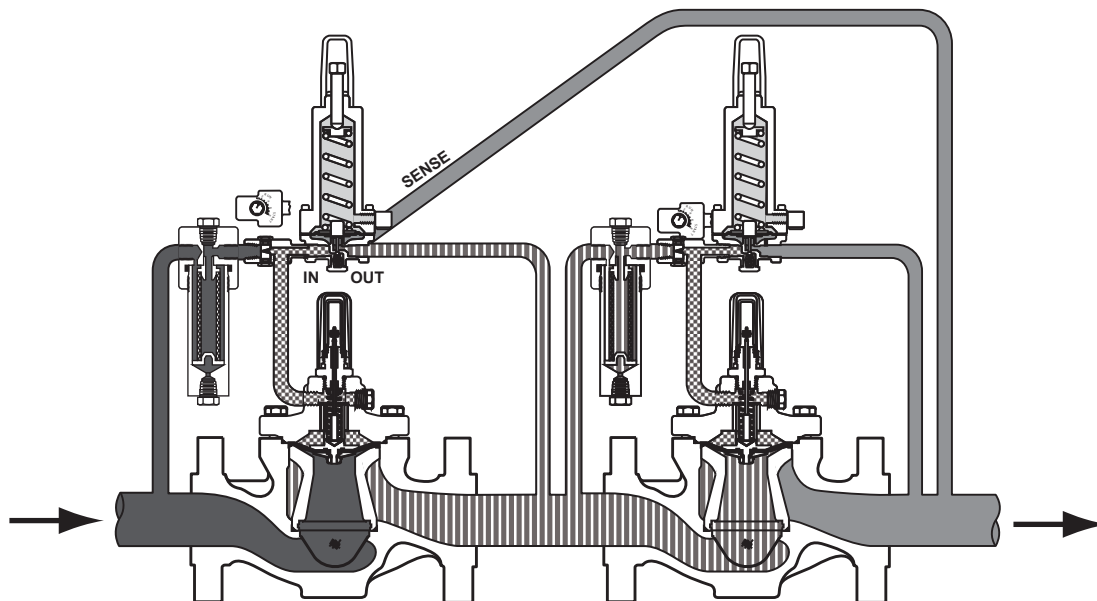

M1128_07/2017

TYPE EZR-161 WIDE-OPEN MONITOR WITH PILOT EXHAUST TO INTERMEDIATE PRESSURE

- INLET PRESSURE
- OUTLET PRESSURE
- ATMOSPHERIC PRESSURE
- ▨ LOADING PRESSURE
- ▤ INTERMEDIATE PRESSURE

Figure 5. Type EZR Wide-Open Monitor Schematic

EZR Series

S - SUPPLY PORT
 B - BLEED PORT
 L - LOADING PORT
 A - SENSING PORT

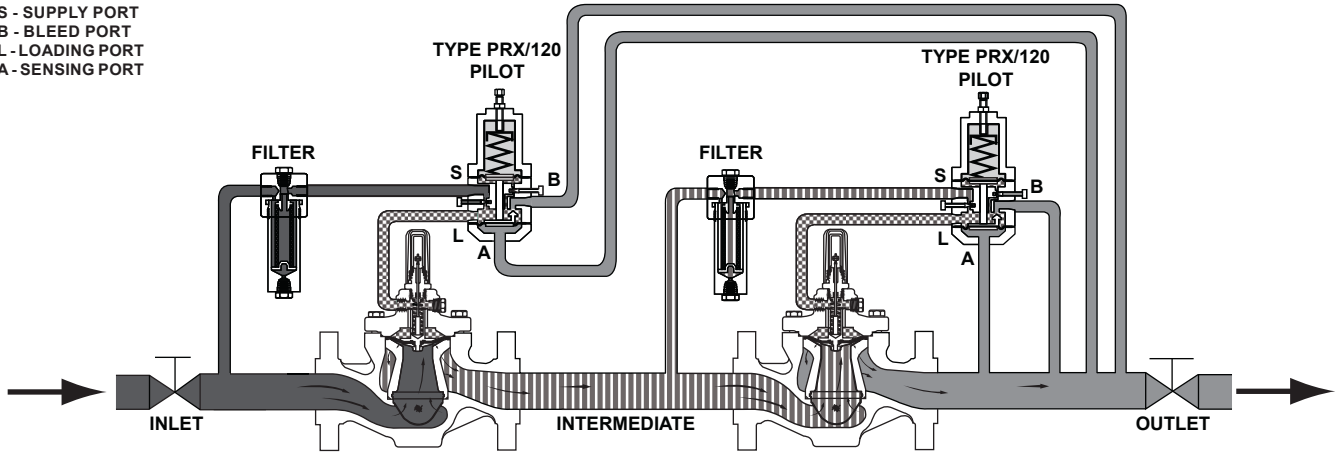

M1252_05/2016

TYPE EZR-PRX WIDE-OPEN MONITOR

S - SUPPLY PORT
 B - BLEED PORT
 L - LOADING PORT
 A - SENSING PORT

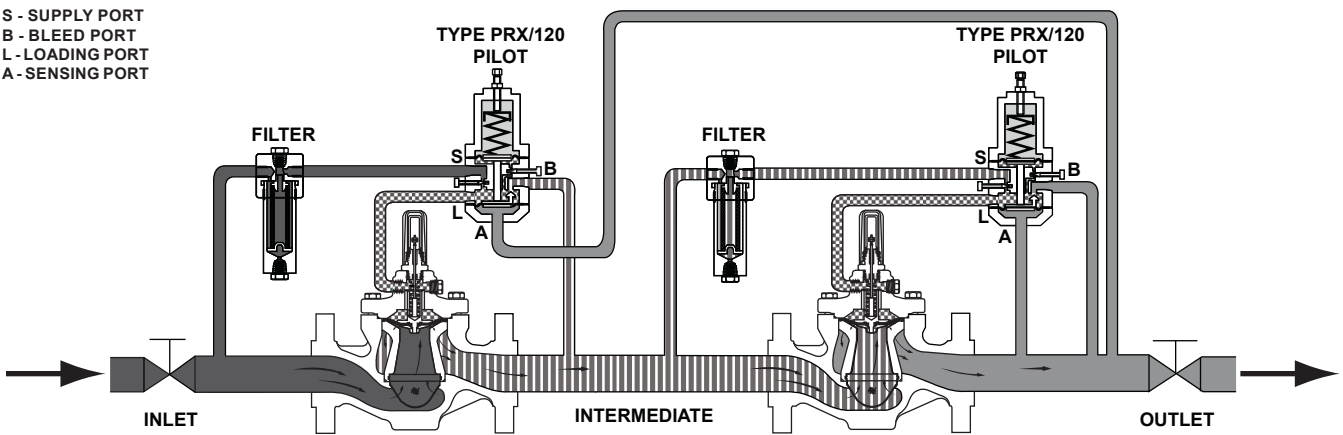

M1000_05/2016

TYPE EZR-PRX WIDE-OPEN MONITOR WITH PILOT EXHAUST TO INTERMEDIATE PRESSURE
 WITH PILOT EXHAUST TO INTERMEDIATE PRESSURE

- INLET PRESSURE
- OUTLET PRESSURE
- ATMOSHERIC PRESSURE
- LOADING PRESSURE
- INTERMEDIATE PRESSURE

Figure 5. Type EZR Wide-Open Monitor Schematic (continued)

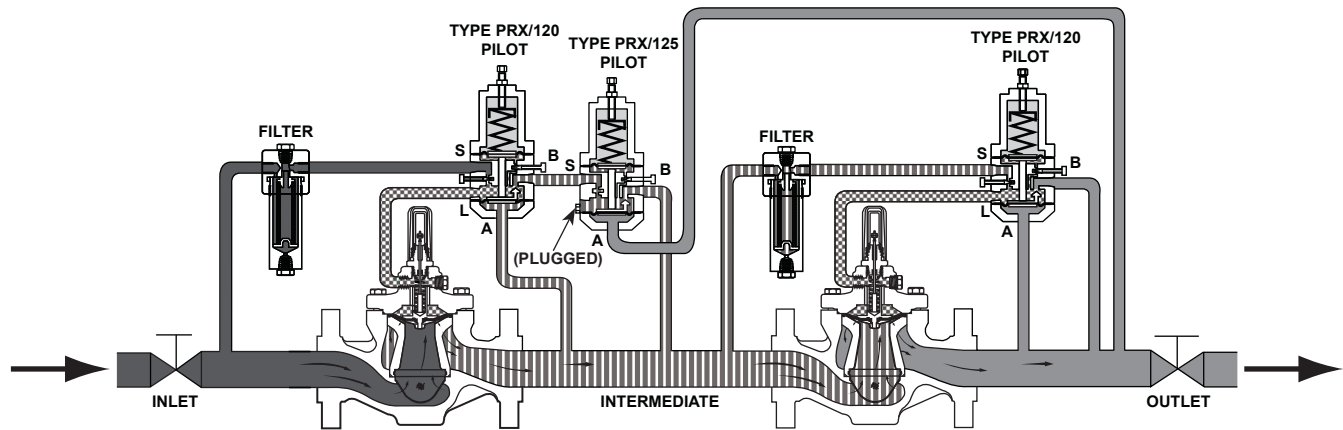

M1001_05/2017





- | | |
|---|------------------|
|  INLET PRESSURE | S - SUPPLY PORT |
|  OUTLET PRESSURE | B - BLEED PORT |
|  ATMOSPHERIC PRESSURE | L - LOADING PORT |
|  LOADING PRESSURE | A - SENSING PORT |
|  INTERMEDIATE PRESSURE | |

Figure 6. Type EZR-PRX-PRX Working Monitor Schematic

For PRX Series pilots (Figure 6), the working pilot is Type PRX-120 or PRX-120AP; the monitor pilot is Type PRX-125 or PRX-125AP.

Note

The downstream regulator must be rated for the maximum allowable operating pressure of the system because this will be its inlet pressure if the monitoring regulator fails. Also, the outlet pressure rating of the monitoring pilot and any other components that are exposed to the intermediate pressure must be rated for full inlet pressure.

Working monitor installations require a Type EZR main valve with a 161AY Series, 161EB Series, Type PRX/120 or PRX/120-AP working pilot and a Type 161AYM, 161EBM, PRX/125 or PRX/125-AP monitoring pilot for the upstream regulator and a Type EZR with the appropriate 161AY Series, 161EB Series, Type PRX/120 or PRX/120-AP pilot for the downstream regulator.

Overpressure Protection

Overpressuring any portion of a regulator or associated equipment may cause personal injury, leakage or property damage due to bursting of pressure-containing parts or explosion of accumulated gas. Provide appropriate pressure relieving or pressure limiting devices to ensure that the limits in the Specifications section are not exceeded. Regulator operation within ratings does not prevent the possibility of damage from external sources or from debris in the pipeline. Common methods of external overpressure protection include relief valves, monitoring regulators and shutoff devices.

Type EZROX regulator relies on the integrated slam-shut device for overpressure (OPSO) or overpressure and underpressure (OPSO/UPS0) protection. In the event that outlet pressure rises above or falls below the pressure setting, slam shut will completely shutoff the flow of gas to the downstream system.

EZR Series

Table 6. Diaphragm Temperature Capabilities, Erosion Resistance and Chemical Compatibility

	17E68 NITRILE (NBR)	17E97 ⁽¹⁾ NITRILE (NBR)	17E88 FLUOROCARBON (FKM)
Gas Temperature (for lower temperatures contact your local Sales Office)	-20 to 150°F / -29 to 66°C	0 to 150°F / -18 to 66°C	0 to 260°F / -18 to 127°C ⁽²⁾
General Applications	Best for cold temperatures.	Best for high pressure conditions, i.e. transmission service or high pressure industrial service. It is also the best for abrasive or erosive service applications.	Best for natural gas having aromatic hydrocarbons. It is also the best for high temperature applications.
Heavy Particle Erosion	Fair	Excellent	Good
Natural Gas With:			
Up to 3% aromatic hydrocarbon content ⁽³⁾	Good	Excellent	Excellent
3 to 15% aromatic hydrocarbon content ⁽³⁾	Poor	Good	Excellent
15 to 50% aromatic hydrocarbon content ⁽³⁾	Not recommended	Poor	Excellent
Up to 3% H ₂ S (hydrogen sulfide or sour gas)	Good	Good	Good
Up to 3% ketone	Fair	Fair	Fair
Up to 10% alcohol	Good	Good	Fair
Up to 3% synthetic lube	Fair	Fair	Good
<small>1. The NPS 6 / DN 150, 17E97 diaphragm will perform in gas temperatures as low as -20°F / -29°C. 2. For differential pressures above 400 psig / 28 bar diaphragm temperature is limited to 150°F / 66°C. 3. The aromatic hydrocarbon content is based on percent volume.</small>			

Capacity Information

Note

Flow capacities are laboratory verified; therefore, regulators may be sized for 100% flow published capacities. It is not necessary to reduce published capacities.

Tables 13 and 14 show the natural gas regulating capacities of the EZR Series regulator at selected inlet pressures and outlet pressure settings. Flows are in thousands of SCFH at 60°F and 14.7 psia (and in thousands of Nm³/h at 0°C and 1.01325 bar) of 0.6 specific gravity natural gas.

To determine equivalent capacities for air, propane, butane or nitrogen, multiply the capacity by the following appropriate conversion factor: 0.775 for air, 0.628 for propane, 0.548 for butane or 0.789 for nitrogen. For gases of other specific gravities, multiply the given capacity by 0.775 and divide by the square root of the appropriate specific gravity.

To find approximate regulating capacities at pressure settings not given in Tables 13 and 14 or to find wide-open flow capacities for relief sizing at any inlet pressure, perform one of the following procedures. Then, if necessary, convert using the factors provided above.

For critical pressure drops (absolute outlet pressure equal to or less than one-half of absolute inlet pressure), use the following formula:

$$Q = (P_1)(C_g)(1.29)$$

For pressure drops lower than critical (absolute outlet pressure greater than one-half of absolute inlet pressure).

$$Q = \sqrt{\frac{520}{GT}} C_g P_1 \text{SIN} \left(\frac{3417}{C_1 \sqrt{\frac{\Delta P}{P_1}}} \right) \text{DEG}$$

where,

- Q = gas flow rate, SCFH
- P₁ = absolute inlet pressure, psia (P₁ gauge + 14.7)
- C_g = regulating or wide-open gas sizing coefficient from Table 9 or 10
- G = gas specific gravity of the gas
- T = absolute temperature of gas at inlet, °Rankine
- C₁ = flow coefficient
- ΔP = pressure drop across the regulator, psi

Then, if capacity is desired in normal cubic meters per hour at 0°C and 1.01325 bar, multiply SCFH by 0.0268.

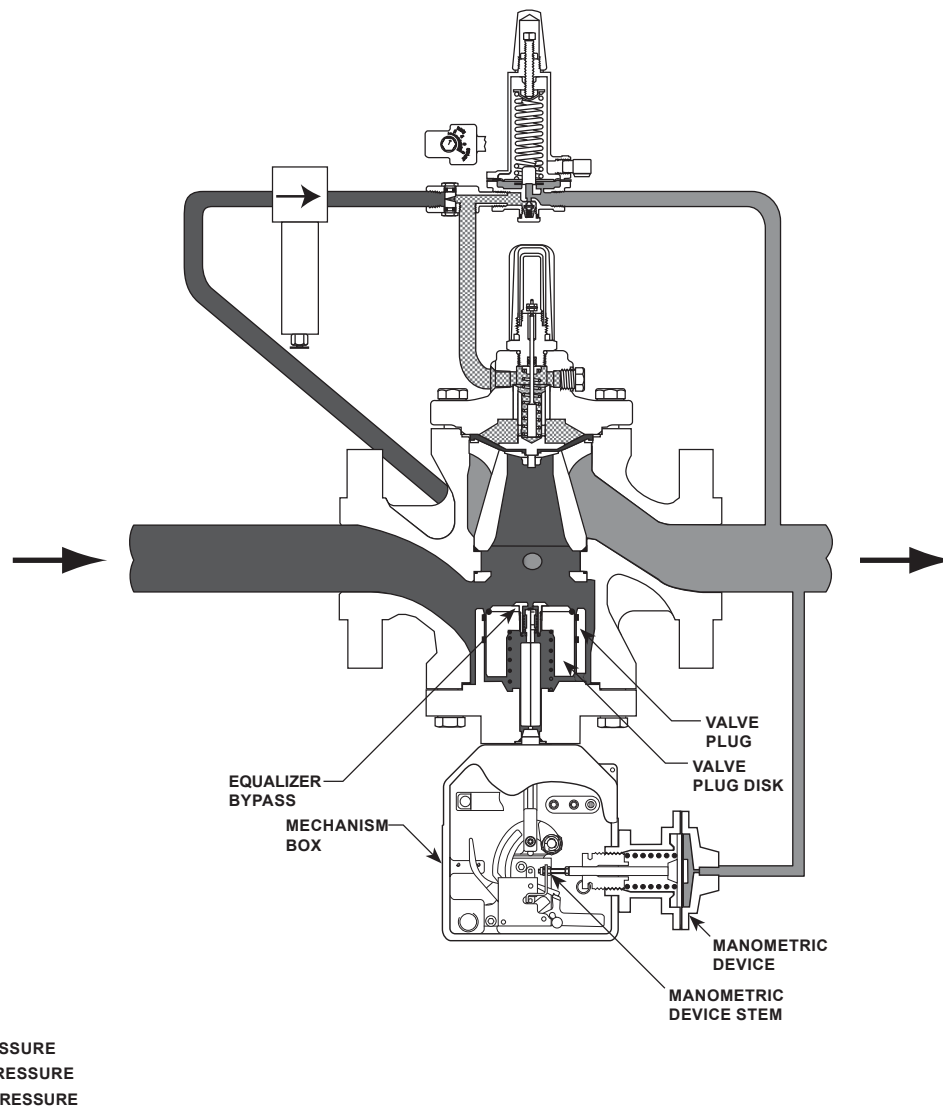

Figure 7. Type EZROX with Slam-shut Device Operational Schematic

When sizing a working monitor setup, size each regulator separately using either the capacity tables or the equation method. When sizing a wide-open monitor setup, first use the equation method, solving for the pressure drop across the monitor at the maximum flow condition. Next, size the worker using either the capacity tables or equation method while taking into account the monitor's maximum pressure drop.

Slam-Shut Device Principle of Operation

The Type EZROX with slam-shut device can provide either overpressure (OPSO) or overpressure and underpressure (OPSO/UPS0) protection by completely shutting off the flow of gas to the

downstream system. The slam shut has a mechanism box and a manometric device. The manometric device is a spring and diaphragm actuator. Its movement activates the detection stage of the mechanism box. The shutoff is a two stage process, the detection stage and the power stage. This separation between detection stage and power stage provides maximum precision, alleviating many false trips caused by environmental vibrations. The slam-shut device includes a bypass valve that will allow pressure to be equalized when resetting the device. Once the slam-shut device has been tripped, it must be manually reset. For more information about the Type EZROX, contact your local Sales Office.

EZR Series

Table 7. Main Valve Maximum Pressure Ratings, Diaphragm Selection Information and Main Spring Selection⁽¹⁾

BODY SIZES		DIAPHRAGM MATERIAL	MAXIMUM OPERATING INLET PRESSURE ⁽⁴⁾		MAXIMUM OPERATING DIFFERENTIAL PRESSURE ⁽⁴⁾		MAXIMUM EMERGENCY INLET AND DIFFERENTIAL PRESSURE		MAIN SPRING COLOR	DIAPHRAGM DESIGNATION
NPS	DN		psig	bar	psid	bar d	psid	bar d		
1 and 1-1/4 x 1	25 and 32 x 25	17E68 Nitrile (NBR) Low temperature	100	6.9	100	6.9	100	6.9	Light Blue	
			460	32	400	28	460	32	Black	
		17E97 Nitrile (NBR) High-pressure and/or erosion resistance	500	34	500	34	1050	72	Black	
			1050	72	800	55	1050	72	Black with White Stripe ⁽²⁾	
		17E88 Fluorocarbon (FKM) High aromatic hydrocarbon content resistance	100	6.9	100	6.9	100	6.9	Light Blue	
			500	34	500 ⁽³⁾	34 ⁽³⁾	750	52	Black	
		750	52	500 ⁽³⁾	34 ⁽³⁾	750	52	Black with White Stripe ⁽²⁾		
2 x 1	50 x 25	17E68 Nitrile (NBR) Low temperature	100	6.9	100	6.9	100	6.9	Light Blue	
			360	25	300	21	360	25	Black with White Stripe	
		17E97 Nitrile (NBR) High-pressure and/or erosion resistance	500	34	500	34	500	34	Black with White Stripe	
			1050	72	800	55	1050	72	Red Stripe ⁽²⁾	
		17E88 Fluorocarbon (FKM) High aromatic hydrocarbon content resistance	100	6.9	100	6.9	100	6.9	Light Blue	
			750	52	500	34 ⁽³⁾	750	52	Black with White Stripe	
2	50	17E68 Nitrile (NBR) Low temperature	100	6.9	100	6.9	100	6.9	Yellow	
			460	32	400	28	460	32	Green	
		17E97 Nitrile (NBR) High-pressure and/or erosion resistance	500	34	500	34	1050	72	Green	
			1050	72	800	55	1050	72	Red or Purple ⁽²⁾	
		17E88 Fluorocarbon (FKM) High aromatic hydrocarbon content resistance	100	6.9	100	6.9	100	6.9	Yellow	
			500	34	500 ⁽³⁾	34 ⁽³⁾	750	52	Green	
		750	52	500 ⁽³⁾	34 ⁽³⁾	750	52	Red or Purple ⁽²⁾		
3	80	17E68 Nitrile (NBR) Low temperature	100	6.9	100	6.9	100	6.9	Yellow	
			360	25	300	21	500	34	Light Blue	
		17E97 Nitrile (NBR) High-pressure and/or erosion resistance	500	34	500	34	1050	72	Light Blue	
			1050	72	800	55	1050	72	Black ⁽²⁾	
		17E88 Fluorocarbon (FKM) High aromatic hydrocarbon content resistance	100	6.9	100	6.9	100	6.9	Yellow	
			500	34	500 ⁽³⁾	34 ⁽³⁾	750	52	Light Blue	
		750	52	500 ⁽³⁾	34 ⁽³⁾	750	52	Black ⁽²⁾		
4, 6 x 4 and 8 x 4	100, 150 x 100 and 200 x 100	17E68 Nitrile (NBR) Low temperature	100	6.9	100	6.9	100	6.9	Yellow	
			360	25	300	21	500	34	Green	
		17E97 Nitrile (NBR) High-pressure and/or erosion resistance	500	34	500	34	1050	72	Green	
			1050	72	800	55	1050	72	Red ⁽²⁾	
		17E88 Fluorocarbon (FKM) High aromatic hydrocarbon content resistance	100	6.9	100	6.9	100	6.9	Yellow	
			500	34	500 ⁽³⁾	34 ⁽³⁾	750	52	Green	
		750	52	500 ⁽³⁾	34 ⁽³⁾	750	52	Red ⁽²⁾		
6, 8 x 6 and 12 x 6	150, 200 x 150 and 300 x 150	17E97 Nitrile (NBR) High-pressure and/or erosion resistance	100	6.9	100	6.9	100	6.9	Yellow	
			500	34	500	34	1050	72	Green	
			1050	72	800	55	1050	72	Red ⁽²⁾	
		17E88 Fluorocarbon (FKM) High aromatic hydrocarbon content resistance	100	6.9	100	6.9	100	6.9	Yellow	
			500	34	500 ⁽³⁾	34 ⁽³⁾	750	52	Green	
			750	52	500 ⁽³⁾	34 ⁽³⁾	750	52	Red ⁽²⁾	
8	200	17E97 Nitrile (NBR) High-pressure and/or erosion resistance	100	6.9	100	6.9	100	6.9	Yellow	
			500	34	500	34	1050	72	Green	
			1050	72	800	55	1050	72	Red ⁽²⁾	

130

1. See Table 1 for main valve structural design ratings and Table 3 for pilot ratings.
 2. The red, black, purple, red stripe and black with white stripe springs are only recommended for applications where the maximum inlet pressure can exceed 500 psig / 34.5 bar.
 3. For differential pressures above 400 psid / 27.6 bar d diaphragm temperatures are limited to 150°F / 66°C.
 4. These are recommendations that provide the best regulator performance for a typical application. Please contact your local Sales Office for further information if a deviation from the standard recommendations are required.

Table 8. IEC Sizing Coefficients⁽¹⁾

MAIN VALVE BODY SIZE, NPS / DN	X _T	F _D	F _L
1 / 25	0.71	0.06	0.94
2 / 50	0.88	0.09	0.96
3 / 80	0.95	0.09	0.97
4 / 100	0.95	0.09	0.92
6 / 150	0.81	0.13	0.91
8 / 200	0.96	0.10	0.89

1. At 100% capacity.

Table 9. Main Valve Regulating Flow Coefficients⁽¹⁾ for EZR Series, With or Without Slam-Shut Device

MAIN VALVE BODY SIZE, NPS / DN	CAGE STYLE, PERCENT OF CAPACITY	LINE SIZE EQUALS BODY SIZE PIPING						2:1 LINE SIZE TO BODY SIZE PIPING					
		With Inlet Strainer			Without Inlet Strainer			With Inlet Strainer			Without Inlet Strainer		
		C _g	C _v	C ₁	C _g	C _v	C ₁	C _g	C _v	C ₁	C _g	C _v	C ₁
1 / 25	100%	494	14.8	33.4	494	15.3	32.4	481	14.4	33.4	478	14.6	32.7
	60%	290	10.1	28.7	282	9.8	28.9	286	9.9	29.0	275	9.5	28.9
	30%	145	5.0	28.8	141	4.9	28.7	144	5.0	28.6	139	4.9	28.5
1-1/4 x 1 / 32 x 25	100%	572	17.0	33.7	573	16.5	34.6	547	16.1	34.1	550	15.9	34.7
	60%	283	10.5	26.9	291	10.8	26.9	293	10.9	26.7	303	11.3	26.9
	30%	145	5.5	26.3	149	5.6	26.4	142	5.4	26.1	147	5.6	26.3
2 x 1 / 50 x 25	100%	650	18.4	35.3	650	18.4	35.3	648	18.2	35.6	645	18.2	35.4
	60%	294	10.9	27.0	294	10.9	27.0	294	10.9	27.0	294	10.9	27.0
	30%	145	5.1	28.3	145	5.1	28.2	145	5.1	28.3	145	5.1	28.4
2 / 50	100%	1890	50.8	37.2	1970	54.6	36.1	1800	50.4	35.7	1840	53.0	34.7
	60%	1040	35.6	29.2	1050	36.3	28.9	1020	35.9	28.4	1020	35.9	28.4
	30%	570	21.4	26.6	570	21.4	26.6	560	21.5	26.0	560	21.5	26.0
3 / 80	100%	3550	91.4	38.8	3720	99.9	37.2	3390	90.6	37.4	3510	97.1	36.1
	60%	2000	70.3	28.5	2000	70.3	28.5	1970	67.5	29.2	1970	68.3	28.8
	30%	980	38.0	25.8	980	38.0	25.8	970	36.9	26.3	970	36.9	26.3
4 / 100	100%	5690	147	38.7	5830	154	37.9	5540	145	38.2	5640	151	37.4
	60%	3360	124	27.1	3360	124	27.1	3300	122	27.0	3300	121	27.3
	30%	1710	66.5	25.7	1710	66.5	25.7	1690	66.3	25.5	1690	66.8	25.3
6 x 4 / 150 x 100	100%	6150	159	38.7	6290	166	37.9	6142	161	38.2	6242	167	37.4
	60%	3790	140	27.1	3810	141	27.1	3930	146	27.0	3890	143	27.3
	30%	1900	74	25.7	1910	74	25.7	1970	77	25.5	1950	77	25.3
8 x 4 / 200 x 100	100%	6030	156	38.7	6170	163	37.9	5934	155	38.2	6034	161	37.4
	60%	3640	134	27.1	3700	137	27.1	3720	138	27.0	3730	137	27.3
	30%	1830	71	25.8	1860	72	25.8	1870	73	25.6	1880	74	25.3
6 / 150	100%	11,600	325	35.7	12,000	337	35.6	11,200	314	35.7	11,700	329	35.6
	60%	7120	239	29.8	7200	241	29.9	7150	240	29.8	7230	242	29.9
	30%	3560	135	26.4	3560	134	26.6	3570	135	26.4	3590	135	26.6
8 x 6 / 200 x 150	100%	13,400	376	35.7	13,700	385	35.6	12,940	363	35.7	13,360	376	35.6
	60%	8250	277	29.8	8290	277	29.9	8280	278	29.8	8320	279	29.9
	30%	4150	157	26.4	4150	156	26.6	4160	157	26.4	4180	157	26.6
12 x 6 / 300 x 150	100%	13,600	381	35.7	13,700	385	35.6	13,130	368	35.7	13,360	376	35.6
	60%	8210	276	29.8	8220	275	29.9	8240	277	29.8	8250	276	29.9
	30%	4110	155	26.4	4110	155	26.6	4120	156	26.4	4140	156	26.6
8 / 200	100%	19,700	505	39	20,100	517	38.9	19,500	503	38.8	19,700	509	38.7

1. K_m for the NPS 1 / DN 25 body size at 100% capacity is 0.88, the NPS 2 / DN 50 is 0.92, the NPS 3 / DN 80 is 0.94, the NPS 4 / DN 100 is 0.84 and the NPS 6 / DN 150 is 0.82.

EZR Series

Table 10. Main Valve Wide-Open Flow Coefficients for EZR Series, With or Without Slam-Shut Device

MAIN VALVE BODY SIZE, NPS / DN	CAGE STYLE, PERCENT OF CAPACITY	LINE SIZE EQUALS BODY SIZE PIPING						2:1 LINE SIZE TO BODY SIZE PIPING					
		With Inlet Strainer			Without Inlet Strainer			With Inlet Strainer			Without Inlet Strainer		
		C _g	C _v	C ₁	C _g	C _v	C ₁	C _g	C _v	C ₁	C _g	C _v	C ₁
1 / 25	100%	509	15.2	33.5	509	15.7	32.5	495	14.8	33.5	493	15.0	32.9
	60%	299	10.4	28.7	291	10.1	28.8	295	10.1	29.0	284	9.8	28.9
	30%	149	5.2	28.8	145	5.1	28.7	148	5.2	28.6	143	5.0	28.5
1-1/4 x 1 / 32 x 25	100%	590	17.5	33.7	590	17.0	34.6	564	16.5	34.1	566	16.3	34.7
	60%	291	10.8	26.9	299	11.2	26.9	301	11.3	26.7	312	11.6	26.9
	30%	149	5.7	26.3	154	5.8	26.4	146	5.6	26.1	151	5.8	26.3
2 x 1 / 50 x 25	100%	670	19.0	35.3	670	19.0	35.3	667	18.7	35.6	664	18.7	35.4
	60%	303	11.2	27.0	303	11.2	27.0	303	11.2	27.0	303	11.2	27.0
	30%	149	5.3	28.3	149	5.3	28.2	149	5.3	28.3	149	5.3	28.4
2 / 50	100%	1950	52.4	37.2	2030	56.2	36.1	1850	51.8	35.7	1900	54.6	34.7
	60%	1070	36.6	29.2	1080	37.4	28.9	1050	37.0	28.4	1050	37.0	28.4
	30%	590	22.2	26.6	590	22.2	26.6	580	22.3	26.0	580	22.3	26.0
3 / 80	100%	3660	94.1	38.8	3830	102.9	37.2	3490	93.3	37.4	3620	100.2	36.1
	60%	2060	72.4	28.5	2060	72.4	28.5	2030	69.5	29.2	2030	70.0	28.8
	30%	1010	39.1	25.8	1010	39.1	25.8	1000	38.0	26.3	1000	38.0	26.3
4 / 100	100%	5860	151	38.7	6000	158	37.9	5710	149	38.2	5810	155	37.4
	60%	3460	128	27.1	3460	128	27.1	3400	125	27.3	3400	125	27.3
	30%	1760	68.5	25.7	1770	68.2	26.0	1740	68.2	25.5	1740	68.8	25.3
6 x 4 / 150 x 100	100%	6250	162	38.7	6390	169	37.9	6131	161	38.2	6231	167	37.4
	60%	3850	142	27.1	3870	143	27.1	3920	144	27.3	3880	142	27.3
	30%	1940	75	25.7	1940	75	26.0	1970	77	25.5	1950	77	25.3
8 x 4 / 200 x 100	100%	6100	158	38.7	6240	165	37.9	5930	155	38.2	6030	161	37.4
	60%	3680	136	27.1	3750	138	27.1	3720	136	27.3	3720	136	27.3
	30%	1850	72	25.8	1880	72	26.1	1870	73	25.6	1880	74	25.3
6 / 150	100%	11,950	335	35.7	12,360	348	35.5	11,540	323	35.7	12,050	339	35.5
	60%	7330	246	29.8	7420	248	29.9	7360	247	29.8	7450	249	29.9
	30%	3670	139	26.5	3670	138	26.6	3680	139	26.5	3700	139	26.6
8 x 6 / 200 x 150	100%	13,800	386	35.7	14,110	397	35.5	13,330	373	35.7	13,760	387	35.6
	60%	8490	285	29.8	8540	286	29.9	8520	286	29.8	8570	287	29.9
	30%	4280	162	26.5	4280	161	26.6	4290	162	26.5	4310	162	26.6
12 x 6 / 300 x 150	100%	14,010	392	35.7	14,110	397	35.5	13,530	379	35.7	13,760	387	35.6
	60%	8450	284	29.8	8470	283	29.9	8480	285	29.8	8,500	284	29.9
	30%	4240	160	26.5	4240	159	26.6	4250	160	26.5	4,270	160	26.6
8 / 200	100%	20,300	520	39.0	20,700	533	38.8	20,100	518	38.8	20,300	524	38.7

Table 11. Pilot Flow Coefficients

161AY SERIES				161EB SERIES				TYPE PRX		
Orifice Size	C _g	C _v	C ₁	Orifice Size	C _g	C _v	C ₁	C _g	C _v	C ₁
3/32 in. / 2.4 mm	6.9	0.20	35	1/8 in. / 3.18 mm	8.5	0.28	30.4	10.5	0.36	29
1/8 in. / 3.2 mm	12.3	0.35	35							
1/4 in. / 6.4 mm	50	1.43	35							

Table 12. Restrictor Flow Coefficients

SET ON START		SET ON RUN		C ₁
C _g	C _v	C _g	C _v	
6	0.17	1	0.03	35

Table 13. Capacities for EZR Series with Type 161AY or 161AYM Pilot

INLET PRESSURE		OUTLET PRESSURE		CAPACITIES IN THOUSANDS OF SCFH / Nm ³ /h OF 0.6 SPECIFIC GRAVITY NATURAL GAS USING 1:1 LINE SIZE TO BODY SIZE PIPING WITHOUT INLET STRAINER											
				NPS 1 / DN 25		NPS 2 / DN 50		NPS 3 / DN 80		NPS 4 / DN 100		NPS 6 / DN 150		NPS 8 / DN 200	
psig	bar	psig	bar	SCFH	Nm ³ /h	SCFH	Nm ³ /h	SCFH	Nm ³ /h	SCFH	Nm ³ /h	SCFH	Nm ³ /h	SCFH	Nm ³ /h
25	1.7	2.5	0.17	----	----	101	2.7	191	5.1	299	8.0	586	15.7	941	25.2
		3	0.21			95	2.5	177	4.7	275	7.4	583	15.6	936	25.1
		5	0.35			93	2.5	173	4.6	268	7.2	571	15.3	912	24.4
		7	0.48			----	----	----	----	260	7.0	556	14.9	884	23.7
30	2.1	4.5	0.31	28.0	0.7	114	3.1	215	5.8	336	9.0	660	17.7	1062	28.5
		7	0.48	----	----	105	2.8	196	5.2	304	8.1	646	17.3	1033	27.7
35	2.4	6	0.41	31.3	0.8	126	3.4	239	6.4	374	10.0	738	19.7	1187	31.8
		7	0.48	31.1	0.8	119	3.2	223	6.0	346	9.3	732	19.6	1177	31.5
40	2.8	7	0.48	34.5	0.9	139	3.7	262	7.0	411	11.0	817	21.9	1317	35.3
45	3.1			37.9	1.0	152	4.1	286	7.7	449	12.0	900	24.1	1455	39.0
50	3.4			41.2	1.1	164	4.4	310	8.3	487	13.1	981	26.3	1592	42.7
55	3.8			44.4	1.2	177	4.7	334	8.9	524	14.0	1062	28.5	1727	46.3
60	4.1	7	0.48	47.6	1.3	190	5.1	358	9.6	562	15.1	1143	30.6	1862	49.9
65	4.5			50.8	1.4	203	5.4	382	10.2	599	16.1	1223	32.8	1996	53.5
70	4.8			54.0	1.4	215	5.8	406	10.9	637	17.1	1302	34.9	2129	57.1
75	5.2			57.2	1.5	228	6.1	430	11.5	675	18.1	1381	37.0	2261	60.6
80	5.5	7	0.48	60.3	1.6	241	6.5	454	12.2	712	19.1	1460	39.1	2394	64.2
90	6.2			66.6	1.8	253	6.8	478	12.8	750	20.1	1617	43.3	2658	71.2
100	6.9			72.9	1.9	266	7.1	502	13.5	787	21.1	1773	47.5	2920	78.3
125	8.6			88.4	2.4	355	9.5	670	18.0	1051	28.2	2163	58.0	3575	95.8
150	10.3			104	2.8	419	11.2	790	21.2	1239	33.2	2551	68.4	4227	113

Note: Blank areas indicate where minimum main valve differential pressure is not met.

- continued -

Table 13. Capacities for EZR Series with Type 161AY or 161AYM Pilot (continued)

INLET PRESSURE		OUTLET PRESSURE		CAPACITIES IN THOUSANDS OF SCFH / Nm ³ /h OF 0.6 SPECIFIC GRAVITY NATURAL GAS USING 1:1 LINE SIZE TO BODY SIZE PIPING WITHOUT INLET STRAINER											
				NPS 1-1/4 x 1 / DN 32 x 25		NPS 2 x 1 / DN 50 x 25		NPS 6 x 4 / DN 150 x 100		NPS 8 x 4 / DN 200 x 100		NPS 8 x 6 / DN 200 x 150		NPS 12 x 6 / DN 300 x 150	
psig	bar	psig	bar	SCFH	Nm ³ /h	SCFH	Nm ³ /h	SCFH	Nm ³ /h	SCFH	Nm ³ /h	SCFH	Nm ³ /h	SCFH	Nm ³ /h
25	1.7	2.5	0.17	----	----	----	----	299	8.0	294	7.9	669	17.9	669	17.9
		3	0.21					297	8.0	292	7.8	666	17.8	666	17.8
		5	0.35					290	7.8	285	7.6	652	17.5	652	17.5
		7	0.48					281	7.5	277	7.4	634	17.0	634	17.0
30	2.1	4.5	0.31	35.9	1.0	35.9	1.0	337	9.0	331	8.9	754	20.2	754	20.2
		7	0.48	35.1	0.9	----	----	328	8.8	323	8.7	737	19.8	737	19.8
35	2.4	6	0.41	40.1	1.1	40.1	1.1	376	10.1	370	9.9	842	22.6	842	22.6
		7	0.48	39.8	1.1	39.8	1.1	374	10.0	367	9.8	836	22.4	836	22.4
40	2.8	7	0.48	44.4	1.2	44.4	1.2	417	11.2	411	11.0	933	25.0	933	25.0
45	3.1			48.9	1.3	48.9	1.3	461	12.4	454	12.2	1027	27.5	1027	27.5
50	3.4			53.3	1.4	53.3	1.4	504	13.5	496	13.3	1120	30.0	1120	30.0
55	3.8			57.7	1.5	57.7	1.5	546	14.6	537	14.4	1213	32.5	1213	32.5
60	4.1	7	0.48	62.0	1.7	62.0	1.7	588	15.8	579	15.5	1304	34.9	1304	34.9
65	4.5			66.3	1.8	66.3	1.8	630	16.9	620	16.6	1396	37.4	1396	37.4
70	4.8			70.6	1.9	70.6	1.9	672	18.0	661	17.7	1486	39.8	1486	39.8
75	5.2			74.9	2.0	74.9	2.0	714	19.1	702	18.8	1577	42.3	1577	42.3
80	5.5	7	0.48	79.2	2.1	79.2	2.1	755	20.2	743	19.9	1667	44.7	1667	44.7
90	6.2			87.7	2.3	87.7	2.3	838	22.5	825	22.1	1846	49.5	1846	49.5
100	6.9			96.1	2.6	96.1	2.6	920	24.7	906	24.3	2025	54.3	2025	54.3
125	8.6			117	3.1	117	3.1	1126	30.2	1108	29.7	2470	66.2	2470	66.2
150	10.3			138	3.7	138	3.7	1330	35.7	1309	35.1	2913	78.1	2913	78.1

Note: Blank areas indicate where minimum main valve differential pressure is not met.

EZR Series

Table 14a. Capacities for EZR Series with 161EB Series or PRX Series Pilot, NPS 1 to 8 / DN 25 to 200 Body Sizes

INLET PRESSURE		OUTLET PRESSURE		CAPACITIES IN THOUSANDS OF SCFH / Nm ³ /h OF 0.6 SPECIFIC GRAVITY NATURAL GAS USING 1:1 LINE SIZE TO BODY SIZE PIPING WITHOUT INLET STRAINER											
				NPS 1 / DN 25		NPS 2 / DN 50		NPS 3 / DN 80		NPS 4 / DN 100		NPS 6 / DN 150		NPS 8 / DN 200	
psig	bar	psig	bar	SCFH	Nm ³ /h	SCFH	Nm ³ /h	SCFH	Nm ³ /h	SCFH	Nm ³ /h	SCFH	Nm ³ /h	SCFH	Nm ³ /h
30	2.1	5	0.35	28	0.7	107	2.8	200	5.4	310	8.3	658	17.6	1056	28.3
		10	0.69	----	----	101	2.7	188	5.0	292	7.8	623	16.7	991	26.6
40	2.8	8	0.55	34	0.9	139	3.7	262	7.0	411	11.0	812	21.8	1307	35.0
		15	1.0	33	0.9	125	3.3	232	6.2	360	9.6	767	20.6	1221	32.7
		20	1.38	----	----	117	3.1	216	5.8	335	9.0	719	19.3	1134	30.4
50	3.5	12	0.83	41	1.1	164	4.4	310	8.3	487	13.1	961	25.8	1548	41.5
		15	1.0	40	1.1	154	4.1	287	7.7	446	12.0	945	25.3	1516	40.6
		25	1.7	38	1.0	141	3.8	261	7.0	404	10.8	865	23.2	1368	36.7
		30	2.1	----	----	131	3.5	242	6.5	373	10.0	804	21.5	1263	33.8
60	4.1	16	1.1	47	1.3	190	5.1	358	9.6	562	15.1	1111	29.8	1788	47.9
		25	1.7	45	1.2	172	4.6	319	8.5	495	13.3	1055	28.3	1680	45.0
		35	2.4	42	1.1	155	4.1	287	7.7	444	11.9	954	25.6	1501	40.2
		40	2.8	----	----	143	3.8	264	7.1	409	11.0	882	23.6	1380	37.0
75	5.2	22	1.5	57	1.5	228	6.1	430	11.5	675	18.1	1334	35.8	2149	57.6
		35	2.4	54	1.4	203	5.4	378	10.1	585	15.7	1250	33.5	1986	53.2
		50	3.5	47	1.3	175	4.7	322	8.6	498	13.3	1075	28.8	1684	45.1
		55	3.8	----	----	160	4.3	296	7.9	456	12.2	988	26.5	1541	41.3
100	6.9	32	2.2	72	1.9	291	7.8	550	14.7	863	23.1	1707	45.7	2750	73.7
		60	4.1	65	1.7	241	6.5	447	12.0	691	18.5	1485	39.8	2340	62.7
		75	5.2	55	1.5	203	5.4	375	10.1	578	15.5	1252	33.6	1952	52.3
		80	5.5	----	----	186	5.0	342	9.2	527	14.1	1144	30.7	1777	47.6
125	8.6	43	3.0	88	2.4	355	9.5	670	18.0	1051	28.2	2076	55.6	3342	89.6
		60	4.1	85	2.3	321	8.6	595	15.9	923	24.7	1969	52.8	3134	84.0
		90	6.2	71	1.9	261	7.0	482	12.9	745	20.0	1609	43.1	2515	67.4
		105	7.2	----	----	208	5.6	382	10.2	589	15.8	1282	34.4	1985	53.2
150	10.3	52	3.6	104	2.8	419	11.2	790	21.2	1239	33.2	2453	65.7	3953	106
		60	4.1	103	2.8	393	10.5	732	19.6	1137	30.5	2412	64.6	3868	104
		95	6.5	92	2.5	342	9.2	632	16.9	977	26.2	2102	56.3	3308	88.7
		130	9.0	----	----	228	6.1	419	11.2	646	17.3	1406	37.7	2175	58.3
200	13.8	73	5.0	135	3.6	546	14.6	1030	27.6	1615	43.3	3194	85.6	5145	138
		110	7.6	127	3.4	479	12.8	887	23.8	1375	36.9	2941	78.8	4662	125
		150	10.3	106	2.8	390	10.5	720	19.3	1112	29.8	2406	64.5	3753	101
		180	12.4	----	----	264	7.1	484	13.0	746	20.0	1628	43.6	2511	67.3
300	20.7	115	7.9	198	5.3	800	21.4	1510	40.5	2367	63.4	4677	125	7531	202
		170	11.7	186	5.0	698	18.7	1295	34.7	2006	53.8	4292	115	6801	182
		225	15.5	157	4.2	577	15.5	1065	28.5	1645	44.1	3557	95.3	5553	149
		250	17.0	134	3.6	489	13.1	901	24.1	1389	37.2	3019	80.9	4682	125
		280	19.3	----	----	324	8.7	594	15.9	914	24.5	1998	53.5	3076	82.4
400	27.6	155	10.7	261	7.0	1054	28.2	1990	53.3	3119	83.6	6169	165	9936	266
		200	13.8	253	6.8	961	25.8	1785	47.8	2769	74.2	5899	158	9405	252
		250	17.2	237	6.3	883	23.7	1635	43.8	2530	67.8	5432	146	8568	230
		300	20.9	208	5.6	764	20.5	1410	37.8	2177	58.3	4709	126	7352	197
		350	24.1	158	4.2	572	15.3	1052	28.2	1621	43.4	3530	94.6	5458	146
		380	26.0	----	----	374	10.0	686	18.4	1056	28.3	2311	61.9	3552	95.2

1. For outlet pressures above 435 psig / 30 bar, use Type PRX-AP pilot rather than Type PRX.
Note: Blank areas indicate where minimum main valve differential pressure is not met.

- continued -

Table 14a. Capacities for EZR Series with 161EB Series or PRX Series Pilot, NPS 1 to 8 / DN 25 to 200 Body Sizes (continued)

INLET PRESSURE		OUTLET PRESSURE		CAPACITIES IN THOUSANDS OF SCFH / Nm ³ /h OF 0.6 SPECIFIC GRAVITY NATURAL GAS USING 1:1 LINE SIZE TO BODY SIZE PIPING WITHOUT INLET STRAINER											
				NPS 1 / DN 25		NPS 2 / DN 50		NPS 3 / DN 80		NPS 4 / DN 100		NPS 6 / DN 150		NPS 8 / DN 200	
psig	bar	psig	bar	SCFH	Nm ³ /h	SCFH	Nm ³ /h	SCFH	Nm ³ /h	SCFH	Nm ³ /h	SCFH	Nm ³ /h	SCFH	Nm ³ /h
500	34.5	196	13.5	324	8.7	1308	35.1	2470	66.2	3871	104	7656	205	12,331	330
		250	17.2	315	8.4	1195	32.0	2220	59.5	3444	92.3	7334	197	11,697	313
		300	20.7	299	8.0	1121	30.0	2078	55.7	3217	86.2	6894	185	10,900	292
		350	24.1	275	7.4	1018	27.3	1881	50.4	2907	77.9	6268	168	9827	263
		400	28.0	238	6.4	871	23.3	1604	43.0	2475	66.3	5367	144	8348	224
		450	31.0	178	4.8	644	17.3	1183	31.7	1823	48.9	3977	107	6137	164
		480	33.0	----	----	418	11.2	768	20.6	1182	31.7	2586	69.3	3972	106
600	41.4	237	16.3	387	10.4	1562	41.9	2950	79.1	4623	124	9143	245	14,726	395
		250	17.2	386	10.3	1481	39.7	2760	74.0	4287	115	9079	243	14,593	391
		300	20.7	376	10.1	1428	38.3	2655	71.2	4119	111	8770	235	13,989	375
		350	24.1	362	9.70	1358	36.4	2517	67.5	3899	104	8346	224	13,217	354
		400	28.0	340	9.1	1264	33.9	2337	62.6	3614	96.9	7777	208	12,229	328
		500	34.0	265	7.1	966	25.9	1777	47.6	2741	73.5	5956	160	9240	248
		550	38.0	196	5.2	709	19.0	1302	34.9	2006	53.8	4379	117	6749	181
580	40.0	----	----	459	12.3	841	22.5	1295	34.7	2834	76.0	4352	117		
700	48.3	250	17.0	453	12.1	1755	47.0	3278	87.9	5099	134	10,751	288	17,381	466
		278	19.2	450	12.1	1816	48.7	3430	91.9	5375	144	10,630	285	17,121	459
		300	20.7	447	11.9	1715	46.0	3196	85.7	4964	133	10,519	282	16,892	453
		350	24.1	438	11.7	1662	44.5	3090	82.8	4793	128	10,205	273	16,282	436
		400	28.0	424	11.4	1594	42.7	2956	79.2	4579	123	9793	262	15,526	416
		500	34.0	377	10.1	1393	37.3	2572	68.9	3975	107	8577	230	13,435	360
		600	41.0	290	7.8	1052	28.2	1936	51.9	2984	80.0	6493	174	10,055	269
800	55.2	300	21.0	515	13.8	2070	55.5	3910	105	6127	164	12,202	327	19,697	528
		350	24.1	509	13.6	2070	55.5	3910	105	6127	164	11,958	320	19,189	514
		400	28.0	499	13.4	1896	50.8	3525	94.5	5468	147	11,640	312	18,574	498
		500	34.0	467	12.5	1745	46.8	3231	86.6	5001	134	10,732	288	16,938	454
		600	41.0	411	11.0	1512	40.5	2789	74.7	4308	115	9314	250	14,547	390
		700	48.0	312	8.4	1133	30.4	2082	55.8	3209	86.0	6990	187	10,809	290
900	62.1	350	24.1	577	15.5	2325	62.3	4389	118	6879	184	13,651	366	22,008	590
		400	28.0	571	15.3	2184	58.5	4067	109	6316	169	13,396	359	21,486	576
		500	34.0	547	14.7	2064	55.3	3830	103	5935	159	12,679	340	20,133	540
		600	41.0	507	13.6	1886	50.5	3487	93.5	5394	145	11,604	311	18,250	489
		700	48.0	442	11.8	1622	43.5	2991	80.2	4617	124	10,000	268	15,584	418
1000	68.9	350	24.1	644	17.3	2579	69.1	4869	130	7631	205	15,306	410	24,771	664
		400	28.0	639	17.1	2579	69.1	4869	130	7631	205	15,096	405	24,316	652
		500	34.0	622	16.7	2364	63.4	4394	118	6817	183	14,510	389	23,158	621
		600	41.0	592	15.9	2220	59.5	4115	110	6372	171	13,650	366	21,592	579
		700	48.0	545	14.6	2017	54.1	3727	99.9	5762	154	12,420	333	19,480	522
1050	72.4	350	24.1	677	18.1	2706	72.5	5109	137	8007	215	16,124	432	26,138	700
		400	28.0	673	18.0	2706	72.5	5109	137	8007	215	15,932	427	25,710	689
		500	34.0	658	17.6	2509	67.4	4668	125	7245	194	15,398	413	24,627	660
		600	41.0	632	16.9	2379	63.8	4412	118	6826	183	14,618	392	23,181	621
		700	48.0	591	15.8	2196	58.9	4063	109	6283	168	13,517	362	21,261	570
		900	62.0	432	11.6	1572	42.2	2892	77.6	4459	120	9694	260	15,024	403

1. For outlet pressures above 435 psig / 30 bar, use Type PRX-AP pilot rather than Type PRX.
 Note: Blank areas indicate where minimum main valve differential pressure is not met.

EZR Series

Table 14b. Capacities for EZR Series with 161EB Series or PRX Series Pilot, NPS 1-1/4 x 1 to 12 x 6 / DN 32 x 25 to 300 x 150 Body Sizes

INLET PRESSURE		OUTLET PRESSURE		CAPACITIES IN THOUSANDS OF SCFH / Nm ³ /h OF 0.6 SPECIFIC GRAVITY NATURAL GAS USING 1:1 LINE SIZE TO BODY SIZE PIPING WITHOUT INLET STRAINER											
				NPS 1-1/4 x 1 / DN 32 x 25		NPS 2 x 1 / DN 50 x 25		NPS 6 x 4 / DN 150 x 100		NPS 8 x 4 / DN 200 x 100		NPS 8 x 6 / DN 200 x 150		NPS 12 x 6 / DN 300 x 150	
psig	bar	psig	bar	SCFH	Nm ³ /h	SCFH	Nm ³ /h	SCFH	Nm ³ /h	SCFH	Nm ³ /h	SCFH	Nm ³ /h	SCFH	Nm ³ /h
30	2.1	5	0.35	32	0.9	36	1.0	335	8.9	330	8.8	751	20.1	751	20.1
		10	0.69	----	----	----	----	315	8.4	310	8.3	712	19.1	712	19.1
40	2.8	8	0.55	39	1.0	44	1.2	415	11.1	408	10.9	927	24.8	927	24.8
		15	1.0	37	1.0	42	1.1	388	10.4	382	10.2	876	23.5	876	23.5
		20	1.4	----	----	----	----	362	9.7	356	9.5	821	22.0	821	22.0
50	3.5	12	0.8	46	1.2	52	1.4	491	13.2	483	12.9	1098	29.4	1098	29.4
		15	1.0	46	1.2	51	1.4	481	12.9	473	12.7	1079	28.9	1079	28.9
		25	1.7	42	1.1	47	1.3	436	11.7	429	11.5	988	26.5	988	26.5
		30	2.1	----	----	----	----	403	10.8	397	10.6	918	24.6	918	24.6
60	4.1	16	1.1	54	1.4	60	1.6	567	15.2	558	15.0	1268	34.0	1268	34.0
		25	1.7	51	1.4	57	1.5	534	14.3	526	14.1	1204	32.3	1204	32.3
		35	2.4	46	1.2	52	1.4	479	12.8	471	12.6	1089	29.2	1089	29.2
		40	2.8	----	----	----	----	441	11.8	434	11.6	1007	27.0	1007	27.0
75	5.2	22	1.5	64	1.7	73	2.0	681	18.3	671	18.0	1523	40.8	1523	40.8
		35	2.4	61	1.6	68	1.8	632	16.9	622	16.7	1427	38.2	1427	38.2
		50	3.5	52	1.4	59	1.6	538	14.4	529	14.2	1227	32.9	1227	32.9
		55	3.8	----	----	----	----	493	13.2	485	13.0	1128	30.2	1128	30.2
100	6.9	32	2.2	82	2.2	93	2.5	872	23.4	858	23.0	1949	52.2	1949	52.2
		60	4.1	72	1.9	81	2.2	746	20.0	734	19.7	1695	45.4	1695	45.4
		75	5.2	61	1.6	68	1.8	624	16.7	614	16.5	1430	38.3	1430	38.3
		80	5.5	----	----	----	----	569	15.2	560	15.0	1306	35.0	1306	35.0
125	8.6	43	3.0	100	2.7	113	3.0	1060	28.4	1043	28.0	2370	63.5	2370	63.5
		60	4.1	95	2.5	107	2.9	997	26.7	981	26.3	2248	60.2	2248	60.2
		90	6.2	79	2.1	88	2.4	804	21.5	791	21.2	1837	49.2	1837	49.2
		105	7.2	----	----	----	----	636	17.0	626	16.8	1463	39.2	1463	39.2
150	10.3	52	3.6	118	3.2	133	3.6	1253	33.6	1233	33.0	2801	75.1	2801	75.1
		60	4.1	117	3.1	131	3.5	1228	32.9	1208	32.4	2754	73.8	2754	73.8
		95	6.6	102	2.7	114	3.1	1055	28.3	1039	27.8	2400	64.3	2400	64.3
		130	9.0	----	----	----	----	697	18.7	686	18.4	1606	43.0	1606	43.0
200	13.8	73	5.0	154	4.1	174	4.7	1631	43.7	1605	43.0	3647	97.7	3647	97.7
		110	7.6	143	3.8	160	4.3	1485	39.8	1461	39.2	3357	90.0	3357	90.0
		150	10.3	117	3.1	131	3.5	1200	32.2	1181	31.7	2746	73.6	2746	73.6
		180	12.4	----	----	----	----	806	21.6	793	21.2	1858	49.8	1858	49.8
300	20.7	115	7.9	226	6.1	254	6.8	2388	64.0	2350	63.0	5339	143	5339	143
		170	11.7	208	5.6	234	6.3	2166	58.0	2132	57.1	4900	131	4900	131
		225	15.5	174	4.7	194	5.2	1776	47.6	1747	46.8	4061	109	4061	109
		250	17.2	148	4.0	165	4.4	1500	40.2	1476	39.6	3447	92.4	3447	92.4
		280	19.3	----	----	----	----	987	26.5	972	26.0	2281	61.1	2281	61.1
400	27.6	155	10.7	298	8.0	335	9.0	3150	84.4	3100	83.1	7043	189	7043	189
		200	13.8	286	7.7	321	8.6	2990	80.1	2943	78.9	6734	180	6734	180
		250	17.2	264	7.1	296	7.9	2732	73.2	2689	72.1	6202	166	6202	166
		300	20.7	230	6.2	257	6.9	2351	63.0	2313	62.0	5376	144	5376	144
		350	24.1	173	4.6	193	5.2	1750	46.9	1722	46.2	4030	108	4030	108
		380	26.2	----	----	----	----	1141	30.6	1123	30.1	2638	70.7	2638	70.7

1. For outlet pressures above 435 psig / 30 bar, use Type PRX-AP pilot rather than Type PRX.
 Note: Blank areas indicate where minimum main valve differential pressure is not met.

- continued -

Table 14b. Capacities for EZR Series with 161EB Series or PRX Series Pilot, NPS 1-1/4 x 1 to 12 x 6 / DN 32 x 25 to 300 x 150 Body Sizes (continued)

INLET PRESSURE		OUTLET PRESSURE		CAPACITIES IN THOUSANDS OF SCFH / Nm ³ /h OF 0.6 SPECIFIC GRAVITY NATURAL GAS USING 1:1 LINE SIZE TO BODY SIZE PIPING WITHOUT INLET STRAINER											
				NPS 1-1/4 x 1 / DN 32 x 25		NPS 2 x 1 / DN 50 x 25		NPS 6 x 4 / DN 150 x 100		NPS 8 x 4 / DN 200 x 100		NPS 8 x 6 / DN 200 x 150		NPS 12 x 6 / DN 300 x 150	
psig	bar	psig	bar	SCFH	Nm ³ /h	SCFH	Nm ³ /h	SCFH	Nm ³ /h	SCFH	Nm ³ /h	SCFH	Nm ³ /h	SCFH	Nm ³ /h
500	34.5	196	13.5	369	9.9	416	11.1	3910	105	3847	103	8740	234	8740	234
		250	17.2	355	9.5	399	10.7	3719	99.7	3659	98.1	8373	224	8373	224
		300	20.9	335	9.0	375	10.1	3473	93.1	3418	91.6	7870	211	7870	211
		350	24.1	305	8.2	342	9.2	3139	84.1	3089	82.8	7156	192	7156	192
		400	28.0	262	7.0	293	7.8	2672	71.6	2630	70.5	6128	164	6128	164
		450	31.0	195	5.2	217	5.8	1969	52.8	1937	51.9	4540	122	4540	122
		480	33.1	----	----	----	----	1276	34.2	1256	33.7	2952	79.1	2952	79.1
600	41.4	237	16.3	441	11.8	497	13.3	4669	125	4595	123	10,438	280	10,438	280
		250	17.2	438	11.7	493	13.2	4629	124	4556	122	10,365	278	10,365	278
		300	20.9	424	11.4	477	12.8	4447	119	4376	117	10,012	268	10,012	268
		350	24.1	405	10.9	454	12.2	4210	113	4143	111	9528	255	9528	255
		400	28.0	378	10.1	424	11.4	3903	105	3841	103	8879	238	8879	238
		500	34.5	291	7.8	325	8.7	2960	79.3	2913	78.1	6800	182	6800	182
		550	38.0	215	5.8	239	6.4	2166	58.0	2131	57.1	4999	134	4999	134
580	40.0	----	----	----	----	1398	37.5	1376	37.0	3236	86.7	3236	86.7		
700	48.3	250	17.2	518	13.9	584	15.6	5505	148	5418	145	12,274	329	12,274	329
		278	19.2	513	13.7	578	15.5	5428	145	5342	143	12,136	325	12,136	325
		300	20.7	508	13.6	572	15.3	5360	144	5275	141	12,009	322	12,009	322
		350	24.1	494	13.2	555	14.9	5175	139	5093	136	11,650	312	11,650	312
		400	28.0	475	12.7	533	14.3	4944	132	4865	130	11,180	300	11,180	300
		500	34.5	418	11.2	467	12.5	4292	115	4224	113	9793	262	9793	262
		600	41.4	318	8.5	354	9.5	3222	86.4	3171	85.0	7413	199	7413	199
800	55.2	300	21.0	588	15.8	663	17.8	6241	167	6142	165	13,931	373	13,931	373
		350	24.1	578	15.5	650	17.4	6090	163	5993	161	13,652	366	13,652	366
		400	28.0	563	15.1	633	17.0	5904	158	5810	156	13,289	356	13,289	356
		500	34.5	522	14.0	584	15.7	5400	145	5314	142	12,253	328	12,253	328
		600	41.4	454	12.2	508	13.6	4651	125	4577	123	10,634	285	10,634	285
		700	48.0	342	9.2	381	10.2	3465	92.9	3410	91.4	7980	214	7980	214
900	62.1	350	24.1	658	17.6	742	19.9	6976	187	6865	184	15,584	418	15,584	418
		400	28.0	647	17.3	728	19.5	6820	183	6711	180	15,294	410	15,294	410
		500	34.5	615	16.5	690	18.5	6408	172	6306	169	14,475	388	14,475	388
		600	41.4	565	15.1	632	16.9	5824	156	5731	154	13,247	355	13,247	355
		700	48.0	488	13.1	545	14.6	4985	134	4906	131	11,416	306	11,416	306
1000	68.9	350	24.1	737	19.8	831	22.3	7844	210	7719	207	17,474	468	17,474	468
		400	28.0	728	19.5	820	22.0	7709	207	7587	203	17,235	462	17,235	462
		500	34.5	702	18.8	789	21.1	7361	197	7243	194	16,566	444	16,566	444
		600	41.4	663	17.8	743	19.9	6880	184	6770	181	15,584	418	15,584	418
		700	48.0	605	16.2	677	18.1	6221	167	6122	164	14,179	380	14,179	380
1050	72.4	350	24.1	776	20.8	875	23.5	8273	222	8141	218	18,408	493	18,408	493
		400	28.0	768	20.6	866	23.2	8147	218	8018	215	18,189	487	18,189	487
		500	34.5	745	20.0	837	22.4	7823	210	7699	206	17,579	471	17,579	471
		600	41.4	709	19.0	796	21.3	7381	198	7263	195	16,688	447	16,688	447
		700	48.0	658	17.6	736	19.7	6784	182	6677	179	15,432	414	15,432	414
		900	62.0	474	12.7	529	14.2	4811	129	4719	127	11,068	297	11,068	297

1. For outlet pressures above 435 psig / 30 bar, use Type PRX-AP pilot rather than Type PRX.
 Note: Blank areas indicate where minimum main valve differential pressure is not met.

EZR Series

Table 15. Manometric Device Specifications⁽¹⁾

SPRING RANGE		SPRING COLOR	SPRING PART NUMBER	MAXIMUM SENSING INLET PRESSURE		MANOMETRIC SENSING DEVICE TYPE	MANOMETRIC SENSING DEVICE STYLE	SETPOINT TOLERANCE ⁽¹⁾		MAXIMUM DIFFERENCE BETWEEN OVERPRESSURE AND UNDERPRESSURE ⁽²⁾	
psig	bar			psig	bar			psig	bar	psig	bar
4.02 to 14.1 in. w.c.	10 to 35 mbar	Purple	T14232T0012	75	5.2	162	Diaphragm	0.058	0.004	0.145	0.01
9.97 to 33.2 in. w.c.	25 to 83 mbar	Orange	T14233T0012					0.073	0.005	0.363	0.03
18 in. w.c. to 2.0 psig	45 mbar to 0.14 bar	Red	T14234T0012					0.145	0.01	0.725	0.05
1.0 to 3.5	0.07 to 0.24	Yellow	T14235T0012					0.203	0.01	0.870	0.06
1.7 to 5.6	0.11 to 0.38	Green	T14236T0012					0.261	0.02	2.18	0.15
2 to 11	0.14 to 0.75	Gray	T14238T0012					0.725	0.05	5.08	0.35
4 to 19	0.25 to 1.3	Brown	T14239T0012					1.16	0.08	8.70	0.60
7 to 33	0.45 to 2.3	Black	T14240T0012					2.47	0.17	16.0	1.1
15 to 75	1.0 to 5.1	Blue	T14237T0012	235	16.2	71	Diaphragm	5.08	0.35	36.3	2.5
31 to 161	2.1 to 11.0	Brown	T14239T0012					10.2	0.70	79.8	5.5
59 to 235	4.0 to 16.0	Black	T14240T0012					23.2	1.6	145	10.0
235 to 323	16.0 to 22.0	Brown	T14239T0012	1470	100	27	Piston	43.5	3.0	Requires use of Types BMS1 and BMS2	
323 to 588	22.0 to 40.0	Black	T14240T0012					94.3	6.5		
588 to 808	40.0 to 55.0	Brown	T14239T0012	1470	100	17		102	7.0		
808 to 1470	55.0 to 100	Black	T14240T0012					174	12.0		
81 to 323	5.5 to 22.0	Brown	T14239T0012	514	35.4	236	Bellows	14.5	1.00	145	10.0
122 to 514	8.3 to 35.0	Black	T14240T0012					36.3	2.5	290	20.0
257 to 1058	17.5 to 72.0	Gray	T14238T0012					1058	72.9	315	72.5

1. Minimum suggested difference between slam-shut set pressure and normal operating pressure of the system.
 2. Maximum difference between overpressure and underpressure when using one manometric device (Type BMS1) with tripping hook. For underpressure and overpressure points greater than this maximum number, use a second manometric device (Type BMS2) for underpressure protection.

Table 16. Applications and Construction Guide (See Figure 9)

APPLICATION	MECHANISM BOX REQUIRED		MANOMETRIC SENSING DEVICE REQUIRED	
	Type BM1	Type BM2	Type BMS1	Type BMS2
Overpressure Shutoff (OPSO)	Yes	No	Yes	No
Underpressure Shutoff (UPSO)				
Overpressure Shutoff (OPSO) and Underpressure Shutoff (UPSO)			Yes ⁽¹⁾	
Overpressure Shutoff (OPSO) and Underpressure Shutoff (UPSO)	No	Yes	Yes ⁽²⁾	Yes
Overpressure Shutoff (OPSO), Overpressure Shutoff (OPSO) and Underpressure Shutoff (UPSO)			Yes ⁽²⁾	Yes ⁽¹⁾

1. When using one manometric sensing device (Type BMS1 or BMS2) for both overpressure and underpressure shutoff, make sure that the difference between set pressures falls within the maximum range shown in Table 15.
 2. When using two manometric sensing devices (Type BMS1 and a Type BMS2), the Type BMS1 can only be used for high trip.

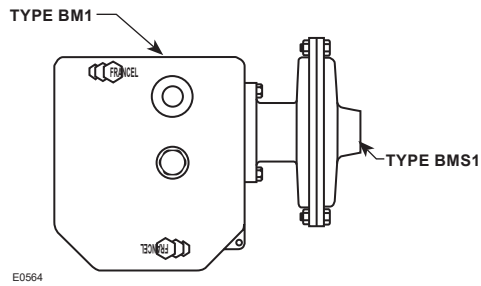

**MECHANISM BOX (TYPE BM1) WITH
1 MANOMETRIC SENSING DEVICE (TYPE BMS1)**

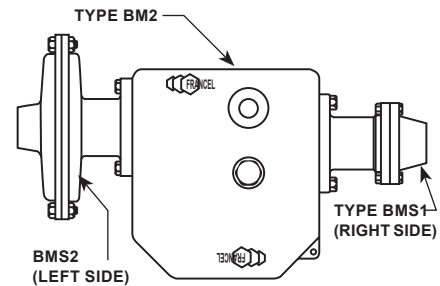

**MECHANISM BOX (TYPE BM2) WITH
2 MANOMETRIC SENSING DEVICES (TYPES BMS1 AND BMS2)**

Figure 8. Types of Installation (Mounting on Horizontal Pipeline Only)

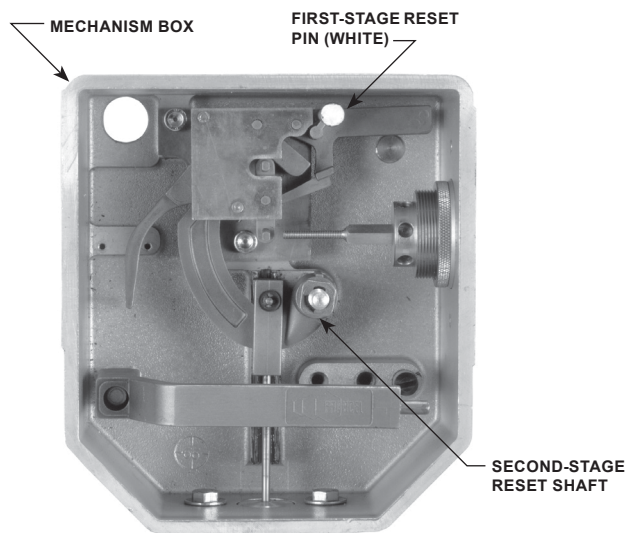

Figure 9. Slam-Shut Device in Open Position

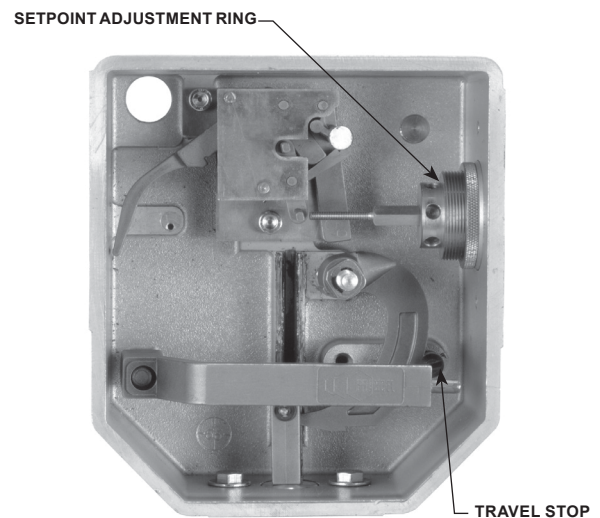

Figure 10. Slam-Shut Device in Closed Position

Table 17. Approximate Weights Including 161EB Series, 161AY Series, PRX Series Pilot and Restrictor⁽¹⁾⁽²⁾

BODY SIZES, NPS / DN	CAST IRON MAIN VALVE BODY, lbs / kg			WCC OR LCC STEEL MAIN VALVE BODY, lbs / kg				WITH INTEGRAL SLAM SHUT, lbs / kg		
	NPT	CL125 FF	CL250 RF	NPT, SWE or BWE	CL150 RF	CL300 RF	CL600 RF	CL150 RF	CL300 RF	CL600 RF
1 and 1-1/4 / 25 and 32	----	----	----	22 / 10	24 / 11	28 / 13	32 / 15	44 / 20	46 / 21	49 / 22
2 and 2 x 1 / 50 and 50 x 25	52 / 24	50 / 23	59 / 27	51 / 23	54 / 24	58 / 26	65 / 29	86 / 39	90 / 41	95 / 43
3 / 80	----	89 / 40	106 / 48	103 / 47	107 / 49	110 / 50	123 / 56	138 / 63	141 / 64	154 / 70
4 / 100		140 / 64	155 / 70	139 / 63	145 / 66	159 / 72	192 / 87	177 / 80	191 / 87	224 / 102
6 x 4 / 150 x 100		----	----	270 / 122	280 / 127	292 / 132	394 / 179	----	----	----
8 x 4 / 200 x 100				390 / 177	461 / 209	515 / 234	600 / 272			
6 / 150		205 / 93	225 / 102	200 / 91	210 / 95	235 / 107	350 / 159	423 / 192	465 / 211	537 / 244
8 x 6 / 200 x 150		----	----	600 / 272	571 / 259	625 / 284	680 / 308	----	----	----
12 x 6 / 300 x 150				1160 / 526	994 / 451	1102 / 500	1590 / 721			
8 / 200				----	635 / 288	685 / 310	790 / 358			

1. Add an additional 15 lbs / 7 kg to get the weight with a 161AY Series pilot.
2. Add an additional 5 lbs / 2 kg to get the weight of PRX Series pilot.

EZR Series

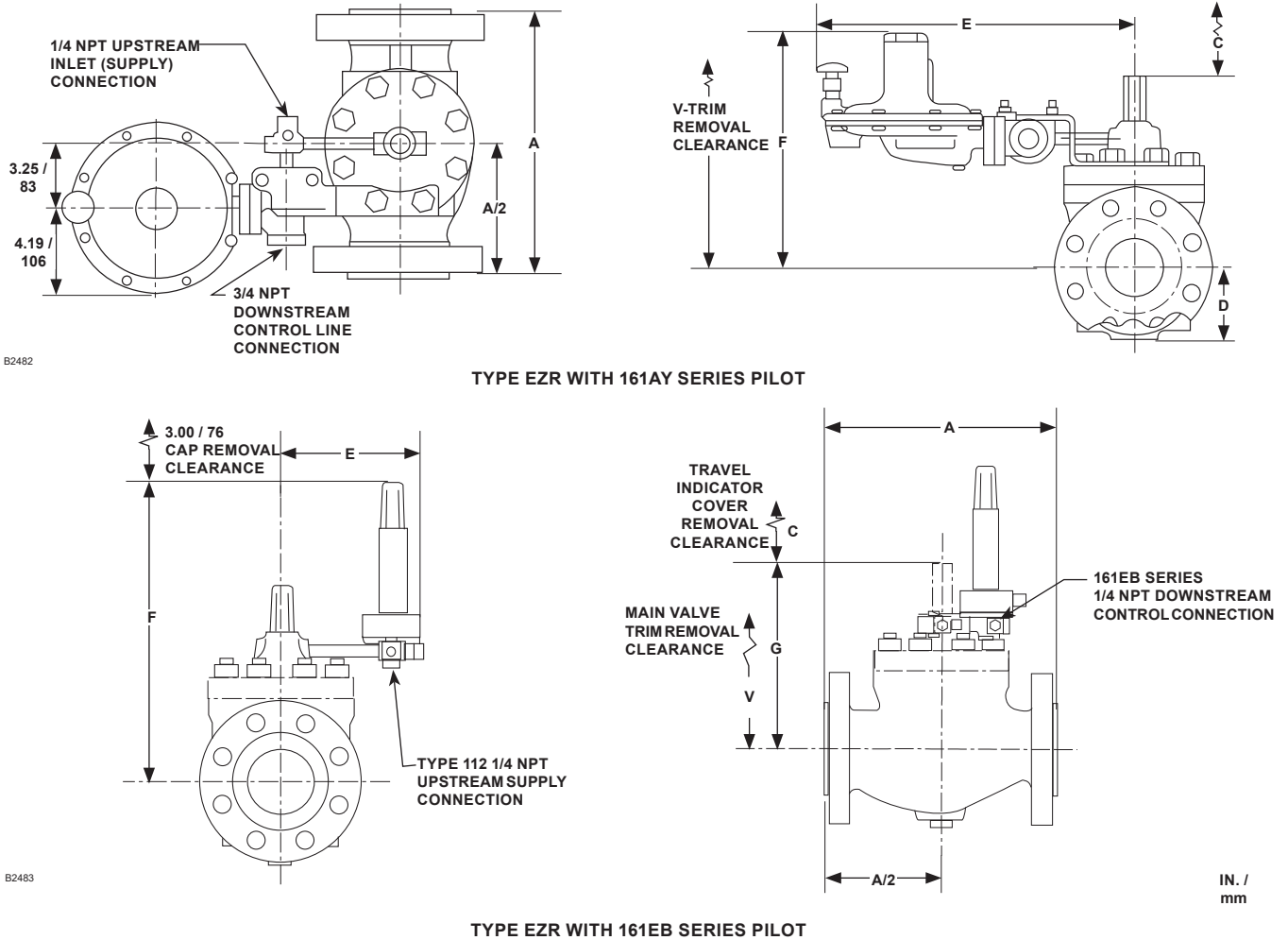
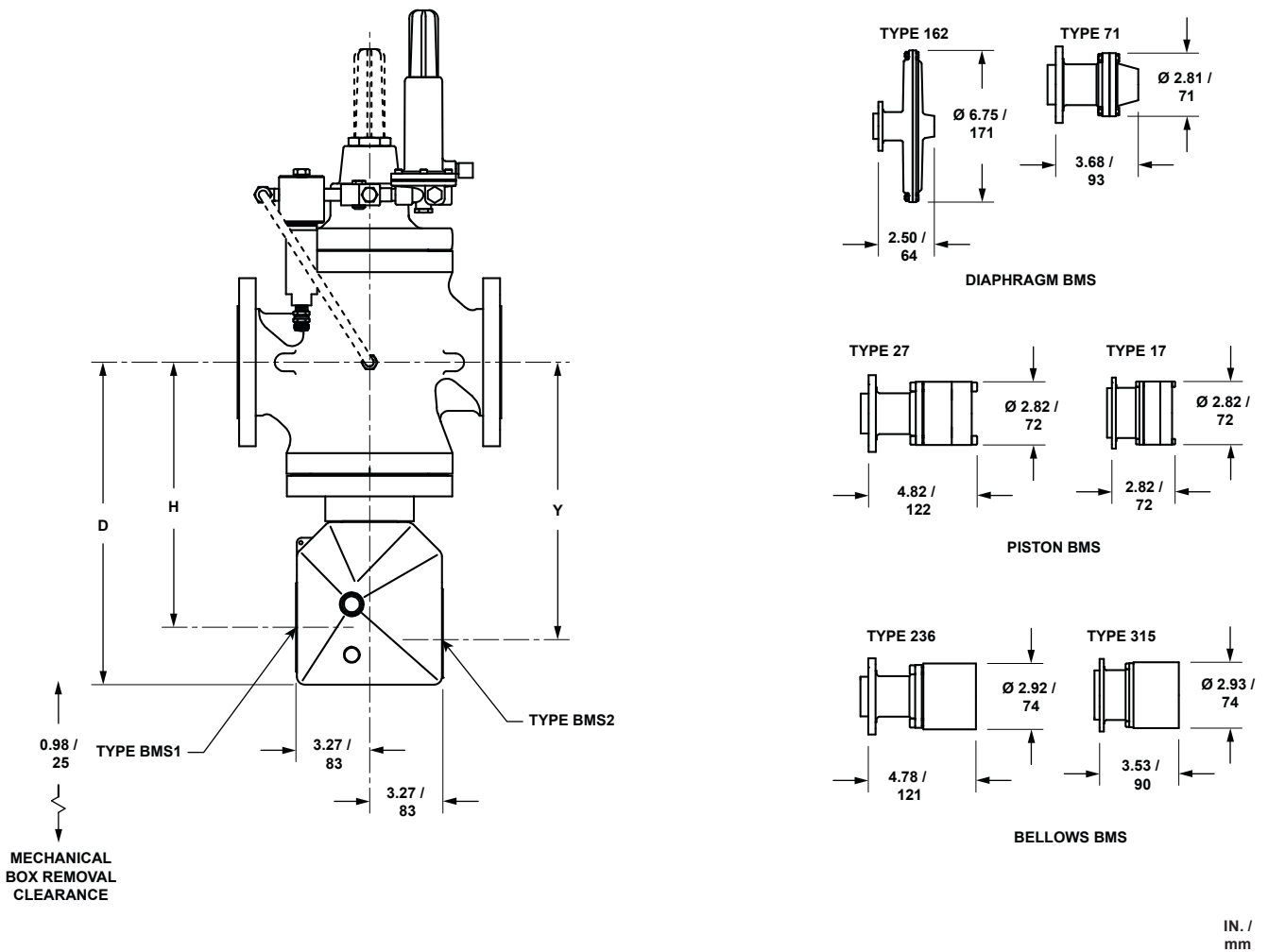

Figure 11. Typical EZR Dimensions

Table 18. Typical EZR Dimensions

BODY SIZE, In. / DN	DIMENSIONS, In. / mm													
	A					E			F			G	V	
	SWE NPT	125FF 150RF	250RF 300RF	600RF BWE	C	D	161AY	161EB	PRX	161AY	161EB			PRX
1, 1-1/4 / 25, 32	8.25 / 210	7.25 / 184	7.75 / 197	8.25 / 210	2 / 51	2.5 / 64	15.7 / 399	6.23 / 158	6.54 / 166	10.1 / 257	12.67 / 322	10.89 / 276	8.67 / 220	8 / 203
2, 2 X 1 / 50, 50 X 25	11.25 / 286	10 / 254	10.5 / 267	11.25 / 286	2 / 51	3.06 / 78	15.8 / 401	6.6 / 168	7.2 / 183	10.17 / 258	12.96 / 329	11.13 / 283	8.9 / 226	11 / 279
3 / 80	----	11.75 / 298	12.5 / 317	13.25 / 337	3.8 / 96	3.81 / 97	16.3 / 414	7.54 / 191	8.21 / 208	11.37 / 289	14.99 / 381	13.6 / 334	12.58 / 319	19.5 / 495
4 / 100	----	13.88 / 353	14.5 / 368	15.5 / 394	3.8 / 96	5.06 / 129	16.7 / 424	7.38 / 187	8.68 / 220	12.75 / 324	16.55 / 420	14.53 / 369	14.72 / 374	20.7 / 526
6 X 4 / 150 X 100	----	17.75 / 451	18.62 / 473	20 / 508	3.8 / 96	5.31 / 135	16.7 / 424	8.96 / 228	8.68 / 220	15.3 / 387	17.87 / 454	14.53 / 369	15.75 / 400	21.6 / 549
8 X 4 / 200 X 100	----	21.38 / 543	22.38 / 568	24 / 610	3.8 / 96	6.94 / 176	16.7 / 424	8.96 / 228	8.68 / 220	15.3 / 387	17.93 / 455	14.53 / 369	15.82 / 402	21.6 / 549
6 / 150	----	17.75 / 451	18.62 / 473	20 / 508	3.8 / 96	5.31 / 135	19.1 / 485	9.86 / 250	10.6 / 269	15.2 / 386	17.78 / 451	16.49 / 419	16.49 / 419	22.8 / 579
8 X 6 / 200 X 150	----	21.38 / 543	22.38 / 568	24 / 610	3.8 / 96	7.2 / 183	19.1 / 485	9.86 / 250	10.6 / 269	16.6 / 422	18.6 / 471	16.49 / 419	16.6 / 422	25.9 / 658
12 X 6 / 300 X 150	----	29 / 737	30.5 / 775	32.25 / 819	3.8 / 96	10 / 254	19.1 / 485	9.86 / 250	10.6 / 269	19.3 / 490	18.6 / 471	16.49 / 419	19.3 / 490	29 / 737
8 / 200	----	21.38 / 543	22.38 / 568	24 / 610	4.5 / 114	8.25 / 210	20.5 / 521	14.5 / 368	13.79 / 349	16.5 / 419	23.5 / 597	15.44 / 392	20.6 / 522	27 / 686



19B8970

TYPE EZROX WITH 161AY SERIES PILOTS AND TYPE 252 FILTER

Figure 12. Typical EZROX Dimensions

Table 19. Typical EZROX Dimensions

BODY SIZE, In. / DN	DIMENSION, In. / mm		
	H	D	Y
1 / 25	9.78 / 248	12.34 / 313	10.33 / 262
2, 2 X 1 / 50, 50 X 25	10.39 / 264	12.95 / 329	10.94 / 278
3 / 80	11.78 / 299	14.34 / 364	12.33 / 313
4 / 100	13.5 / 343	16.06 / 408	14.05 / 357
6 / 150	12.99 / 330	15.55 / 395	13.54 / 344

EZR Series

Ordering Information

The precision slotted cage of the EZR Series regulator offers superior noise attenuation. For a standard installation, as well as to obtain a noise prediction for your installation and service conditions, please complete the specifications worksheet at the bottom of the ordering guide on page 31.

Carefully review each specification, then complete the Ordering Guide on pages 30 and 31. If a pilot setpoint is not requested, the regulator will be factory set at the approximate midrange.

Ordering Guide

Type (Select One)

- EZR
- EZROX (with slam shut)

Body Size (Select)

- NPS 1 / DN 25 (Available in steel only)***
- NPS 1-1/4 x 1 / DN 32 x 25 (Available in NPT steel only)***
- NPS 2 / DN 50***
- NPS 2 x 1 / DN 50 x 25***
- NPS 3 / DN 80***
- NPS 4 / DN 100***
- NPS 6 x 4 / DN 150 x 100***
- NPS 8 x 4 / DN 200 x 100***
- NPS 6 / DN 150***
- NPS 8 x 6 / DN 200 x 150***
- NPS 12 x 6 / DN 300 x 150***
- NPS 8 / DN 200***

Body Material and End Connection Style (Select One)

(NPS 8 / DN 200 size available only in LCC steel CL150, CL300 or CL600 RF)

Cast Iron Body

- NPT (Available in NPS 2 or 2 x 1 / DN 50 or 50 x 25 only)***
- CL125 FF***

WCC or LCC Steel Body

- NPT (Available in NPS 1, 1-1/4 x 1, 2 x 1 or 2 / DN 25, 32 x 25, 50 x 25 or 50 only)***
- CL150 RF***
- CL300 RF***
- CL600 RF***
- SWE (Available in NPS 1, 2 x 1 or 2 / DN 25, 50 x 25 or 50 only)*
- BWE 40**
- PN 16/25/40* _____ specify

Main Valve Diaphragm Material (Select One)

- 17E68 Nitrile (NBR) (low temperature) (Not available on NPS 6 or 8 / DN 150 or 200 size)***
- 17E97 Nitrile (NBR) (high-pressure/erosion resistance)***
- 17E88 Fluorocarbon (FKM) (high aromatic hydrocarbons) (Not available on NPS 8 / DN 200 size)**

Cage, Percent of Full Capacity (Select One)

- 100 percent (**standard**)***
- 60 percent (Not available on 8 / DN 200 size)***
- 30 percent (Not available on 8 / DN 200 size)***

Main Valve O-ring Material (Select One)

- Nitrile (NBR) (**standard**)***
- Fluorocarbon (FKM)**

- continued -

Ordering Guide (continued)

Main Valve Main Spring (See Table 7 for Maximum Inlet Rating) (Select One)

NPS 1, 1-1/4 or 2 x 1 / DN 25 or 50 x 25 Main Valve

- Light Blue***
- Black***
- Black with white stripe***
- Red Stripe***

NPS 2 / DN 50 Main Valve

- Yellow***
- Green***
- Red***
- Purple

NPS 3 / DN 80 Main Valve

- Yellow***
- Light Blue***
- Black***

NPS 4, 6 x 4 or 8 x 4 / DN 100, 200 x 150 or 300 x 150 Main Valve

- Yellow***
- Green***
- Red***

NPS 6, 8 x 6 or 12 x 6 / DN 150, 200 x 150 or 300 x 150 Main Valve

- Yellow***
- Green***
- Red***

NPS 8 / DN 200 Main Valve

- Yellow***
- Green***
- Red***

Travel Indicator (Select One)

- No **(standard)*****
- Yes***

Inlet Strainer (Select One)

- No **(standard)*****
- Yes***

Inlet Body Tap (Select One)

- Inlet body tap only **(standard)*****
- Inlet body tap with pre-piped pilot supply***
- Inlet/outlet body taps only***
- Inlet/outlet body taps with pre-piped pilot supply and pilot bleed***

Pilot Diaphragm Material (Select One)

- Nitrile (NBR) **(standard)*****
- Fluorocarbon (FKM)**

Pilot O-ring Material (Select One)

- Nitrile (NBR) **(standard)*****
- Fluorocarbon (FKM)***

Pilot Valve Plug Material (Select One)

- Nitrile (NBR) **(standard)*****
- Fluorocarbon (FKM)***

- continued -

EZR Series

Ordering Guide (continued)

Pilot Type and Outlet Pressure Range (Select One)

Type 161AY

- 6 to 15 in. w.c. / 15 to 37 mbar, Olive Drab***
- 0.5 to 1.2 psig / 0.03 to 0.08 bar, Yellow***
- 1.2 to 2.5 psig / 0.08 to 0.17 bar, Light Green***
- 2.5 to 4.5 psig / 0.17 to 0.31 bar, Light Blue***
- 4.5 to 7 psig / 0.31 to 0.48 bar, Black***

Type 161AYM

- 6 to 15 in. w.c. / 15 to 37 mbar, Olive Drab***
- 0.5 to 1.2 psig / 0.03 to 0.08 bar, Yellow***
- 1.2 to 2.5 psig / 0.08 to 0.17 bar, Light Green***
- 2.5 to 4.5 psig / 0.17 to 0.31 bar, Light Blue***
- 4.5 to 7 psig / 0.31 to 0.48 bar, Black***

Type 161EB

- 5 to 15 psig / 0.34 to 1.0 bar, White***
- 10 to 40 psig / 0.69 to 2.8 bar, Yellow***
- 30 to 75 psig / 2.1 to 5.2 bar, Black***
- 70 to 140 psig / 4.8 to 9.7 bar, Green***
- 130 to 200 psig / 9.0 to 13.8 bar, Blue***
- 30 to 300 psig / 2.1 to 20.7 bar, Green***
(intermediate reduction pilot on the Type EZR worker/monitor systems)
- 200 to 350 psig / 13.8 to 24.1 bar, Red***

Type 161EBM

- 5 to 15 psig / 0.34 to 1.0 bar, White***
- 10 to 40 psig / 0.69 to 2.8 bar, Yellow***
- 30 to 75 psig / 2.1 to 5.2 bar, Black***
- 70 to 140 psig / 4.8 to 9.7 bar, Green***
- 130 to 200 psig / 9.0 to 13.8 bar, Blue ***
- 200 to 350 psig / 13.8 to 24.1 bar, Red***

Type 161EBH

- 250 to 450 psig / 17.2 to 31.0 bar, Blue***
- 400 to 700 psig / 27.6 to 48.3 bar, Red***

Type 161EBHM

- 250 to 450 psig / 17.2 to 31.0 bar, Blue***
- 400 to 700 psig / 27.6 to 48.3 bar, Red***

Type PRX120/125

- 14.5 to 26 psig / 1.00 to 1.8 bar, Yellow***
- 23 to 44 psig / 1.6 to 3.0 bar, Green***
- 41 to 80 psig / 2.8 to 5.5 bar, Blue***
- 73 to 123 psig / 5.0 to 8 bar, Black***
- 116 to 210 psig / 8 to 14 bar, Silver***
- 203 to 334 psig / 14 to 23 bar, Gold***
- 319 to 435 psig / 22 to 30 bar, Aluminum***

Type PRX120/125-AP

- 435 to 1000 psig / 30 to 69 bar, Clear***

Type 252 Pilot Supply Filter (Optional)

Material

- Stainless steel***
- Aluminum**

Length

- Standard***
- Extended**

Drain Valve

- Yes***
- No**

- continued -

Ordering Guide (continued)

Conversion Trim Package (Optional, Not available for NPS 8 / DN 200 size)

- Yes, send one conversion trim package. (If ordering replacement trim package for change-out of existing E-body to a Type EZR, be sure to mark selection of the following items on this page: body size, diaphragm material, inlet strainer option and travel indicator option desired.)

Main Valve Replacement Parts Kit (Optional)

- Yes, send one diaphragm cartridge and O-rings kit to match this order.
- Yes, send one diaphragm and O-rings kit to match this order.

Pilot Replacement Parts Kit (Optional)

- Yes, send one replacement kit to match this order.

Wireless Position Monitor Mounting Kit (Optional)

- Yes, send one mounting kit for mounting the Topworx 4310 or the Fisher™ 4320 wireless position monitor (requires Travel Indicator option)

Regulators Quick Order Guide	
***	Readily Available for Shipment
**	Allow Additional Time for Shipment
*	Special Order, Constructed from Non-Stocked Parts. Consult your local Sales Office for Availability.
Availability of the product being ordered is determined by the component with the longest shipping time for the requested construction.	

Specification Worksheet
<p>Application (Please designate units): Specific Use _____ Line Size _____ Gas Type and Specific Gravity _____ Gas Temperature _____ Does the Application Require Overpressure Protection? <input type="checkbox"/> Yes <input type="checkbox"/> No If yes, which is preferred: <input type="checkbox"/> Relief Valve <input type="checkbox"/> Monitor Regulator <input type="checkbox"/> Shutoff Device Is overpressure protection equipment selection assistance desired? _____</p>
<p>Pressure: Maximum Inlet Pressure (P_{1max}) _____ Minimum Inlet Pressure (P_{1min}) _____ Downstream Pressure Setting(s) (P_2) _____ Maximum Flow (Q_{max}) _____</p>
<p>Performance Required: Accuracy Requirements? _____ Need for Extremely Fast Response? _____</p>
<p>Other Requirements: _____ _____ _____</p>

EZR Series

✉ Webadmin.Regulators@emerson.com

🔍 Fisher.com

📘 Facebook.com/EmersonAutomationSolutions

🌐 LinkedIn.com/company/emerson-automation-solutions

🐦 Twitter.com/emr_automation

Emerson Automation Solutions

Americas

McKinney, Texas 75070 USA
T +1 800 558 5853
+1 972 548 3574

Europe

Bologna 40013, Italy
T +39 051 419 0611

Asia Pacific

Singapore 128461, Singapore
T +65 6777 8211

Middle East and Africa

Dubai, United Arab Emirates
T +971 4 811 8100

D102626X012 © 1999, 2020 Emerson Process Management Regulator Technologies, Inc. All rights reserved. 08/20.

The Emerson logo is a trademark and service mark of Emerson Electric Co. All other marks are the property of their prospective owners. Fisher™ is a mark owned by Fisher Controls International LLC, a business of Emerson Automation Solutions.

The contents of this publication are presented for informational purposes only, and while every effort has been made to ensure their accuracy, they are not to be construed as warranties or guarantees, express or implied, regarding the products or services described herein or their use or applicability. All sales are governed by our terms and conditions, which are available upon request. We reserve the right to modify or improve the designs or specifications of such products at any time without notice.

Emerson Process Management Regulator Technologies, Inc. does not assume responsibility for the selection, use or maintenance of any product. Responsibility for proper selection, use and maintenance of any Emerson Process Management Regulator Technologies, Inc. product remains solely with the purchaser.

