

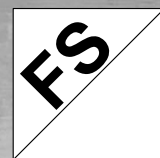

SEW
EURODRIVE

Addendum to the Operating Instructions

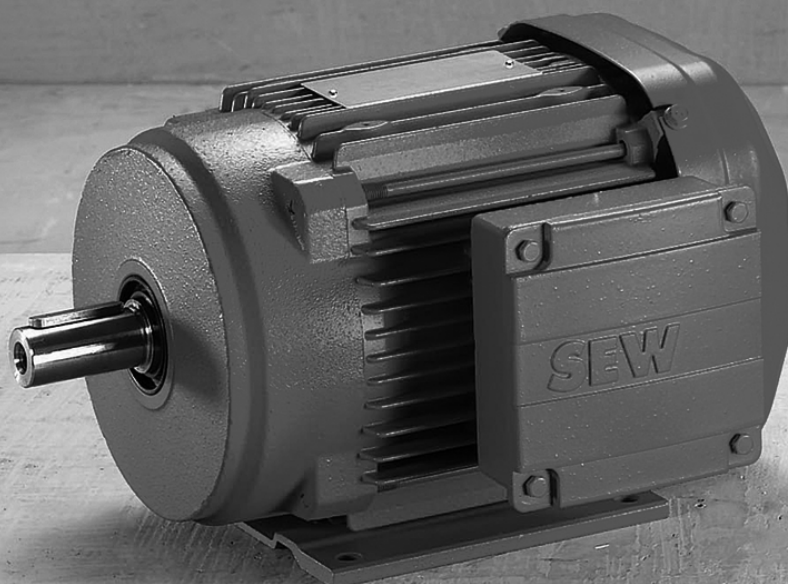

Safety Encoders and Safety Brakes
DR..., DRN..., EDR..., EDRN.. AC Motors
Functional Safety



Table of contents

1	General information	5
1.1	How to use this documentation.....	5
1.2	Content of the documentation.....	5
1.3	Other applicable documentation.....	5
2	Safety notes	6
2.1	Preliminary information.....	6
2.2	Target group.....	6
2.3	Designated use.....	6
3	Functional safety (FS)	9
3.1	Functionally safe motor options.....	9
3.2	FS mark.....	10
3.3	Traceability.....	11
3.4	Underlying standards.....	11
3.5	TÜV certification.....	11
3.6	Safety functions.....	12
3.7	Requirements to the follow-up electronics.....	13
3.8	Brake diagnostics.....	14
3.9	Motor combinations.....	15
3.10	Validation.....	18
4	Motor structure	19
4.1	Nameplates.....	19
5	Mechanical installation	21
5.1	Manual brake release.....	21
6	Electrical installation	22
6.1	Connecting the EI7C FS encoder.....	22
6.2	EI7C FS visual feedback.....	23
6.3	Temperature sensor /TF.....	24
6.4	Brake control.....	25
6.5	Permitted brake controls.....	25
7	Inspection/maintenance	26
7.1	Safety encoder.....	26
7.2	Removing/installing the encoder.....	27
7.3	Measuring wobbling.....	32
7.4	Inspection and maintenance intervals.....	34
7.5	Safety brake.....	35
7.6	Preliminary work for motor and brake maintenance.....	37
7.7	Inspection steps for DR..71 – 225, DRN80 – 225 brakemotors.....	39
7.8	Work steps for brake replacement.....	41
7.9	Diagnostic unit /DUE for function and wear monitoring.....	45
8	Technical data	47
8.1	Safety encoder.....	47
8.2	Safety brake.....	52

Table of contents

9	Declaration of conformity	56
9.1	Safety encoder	56
	Index	58
10	Glossary	59

23480866/EN – 05/2017

1 General information

1.1 How to use this documentation

The current version of the addendum to the operating instructions is the original.

This addendum to the operating instructions contains special information on functionally safe motor options (safety encoder and safety brake) of the DR., DRN., EDRN. motor series.

In addition to the addendum to the operating instructions at hand, the following operating instructions apply for motors with safety encoders and/or safety brakes:

- **AC motors with safety encoder and/or safety brake**
 - "DR..71 – 315, DRN80 – 315 AC Motors" operating instructions
- **Explosion-proof AC motors with safety encoder**
 - "Explosion-Proof ATEX – EDR..71 – 315, EDRN80 – 315 AC Motors" operating instructions or "Explosion-Proof IECEx – EDR..71 – 315, EDRN80 – 315 AC Motors" operating instructions

This documentation is an integral part of the product and contains important information on operation and service. The documentation is written for all employees who assemble, install, start up, and service this product.

Make sure this documentation is accessible and legible. Ensure that persons responsible for the machinery and its operation as well as persons who work on the product independently have read through the documentation carefully and understood it. If you are unclear about any of the information in this documentation, or if you require further information, contact SEW-EURODRIVE.

Make sure you always use the latest documentation and software version.

1.2 Content of the documentation

This documentation contains additional safety-related information and conditions for operation in safety-related applications.

1.3 Other applicable documentation

The following publications and documents have to be observed as well:

- "DR..71 – 315, DRN80 – 315 AC Motors" operating instructions
- "Project Planning for BE.. Brakes – DR., DRN., EDR., EDRN.. AC Motors – Standard Brake/Safety Brake" manual
- "DR.. Series AC Motors" catalog
- "DRN.. Series AC Motors" catalog

When using explosion-proof AC motors, also observe:

- Explosion-Proof ATEX – EDR..71 – 315, EDRN80 – 315 AC Motors
- Explosion-Proof IECEx – EDR..71 – 315, EDRN80 – 315 AC Motors

2 Safety notes

2.1 Preliminary information

The following general safety notes have the purpose to avoid injury and damage to property. They primarily apply to the use of products described in this documentation. If you use additional components also observe the relevant warning and safety notes.

2.2 Target group

2.2.1 Functional safety

Work on a drive with functionally safe motor options – indicated by the FS logo on the motor nameplate – can be performed by the operator.

Any work on the safety encoder and/or the safety brake are carried out at your own risk. The operator is responsible and liable for the proper fulfillment of the work described in the relevant documentation.

The operator has to ensure the traceability of the performed work regarding functional safety. In case of proven compliance with the work described in the operating instructions, the characteristics regarding functional safety described by the manufacturer are maintained.

2.3 Designated use

- DR.., DRN.., EDRN.. motors with functionally safe motor options are intended for industrial systems.
- When installed in machines, startup (i.e. start of designated operation) is prohibited until it is determined that the machine complies with the local laws and directives. The machinery directive, EU directive 2006/42/EC, is relevant for the respective area of application.
- Air-cooled versions are designed for ambient temperatures of -20 °C to +40 °C and installation altitudes ≤ 1000 m above sea level. Any differing specifications on the nameplate must be observed. The ambient conditions must comply with all the specifications on the nameplate.
- In order to determine the safety integrity (performance level PL and/or safety integrity level SIL) of a system's safety functions, the system manufacturer must perform an overall evaluation. This document contains the product-related specifications necessary for the evaluation.
- Operation of DR.., DRN.., EDRN.. motors with functionally safe motor options on third-party inverters is permitted.

2.3.1 Safety encoder

- The safety encoders described in this documentation are intended for use with DR.., DRN.., EDRN.. motors. It is not permitted to mount them to other motors.
- When using a safety encoder in combination with a BE.. brake, the brake may only be used as a holding brake. Braking during operation is not permitted. The designated use of the brake is to activate the brake at standstill ($< 20 \text{ min}^{-1}$). Emergency stops from higher motor speeds are permitted.
- The use of AS7W, AG7W, AS7Y and AG7Y encoders at the inverter requires start-up as an absolute encoder. The sin/cos encoder signals and RS485 and/or SSI have to be evaluated at the inverter.
- The use of AS7W, AG7W, AS7Y and AG7Y encoders in autonomous operation directly at a safe encoder evaluation unit such as MOVISAFE® UCS..B, DCS..B, requires a DC 24 V encoder voltage supply.
- The operation of ES7S and EG7S safety encoders is permitted for ambient temperatures up to a maximum of $+60 \text{ }^\circ\text{C}$. This condition also applies for use in potentially explosive areas.

2.3.2 Safety brake

- The safety brakes described in this documentation are intended for use with DR..., DRN... motors. It is not permitted to mount them to other motors.
 - Operation of the BE.. safety brake in potentially explosive areas is not permitted.
 - When using an AC motor in combination with a BE.. safety brake, the safety brake may only be used as a holding brake. The designated use is to activate the brake at standstill ($< 20 \text{ min}^{-1}$). Emergency stops from higher motor speeds are permitted.
- SEW-EURODRIVE recommends to stop the drive with stop category 1 according to EN 60204-1.
- The dimensioning of drives with BE.. safety brake considers a maximum of 1000 emergency stop braking operations in the life cycle. A minimum pause of 6 minutes must be adhered in between 2 emergency stop braking operations. Project planning clearly defines how often the system can perform the emergency stop braking.
 - When dimensioning the BE.. safety brake, observe the valid project planning specifications of SEW-EURODRIVE and the resulting application limits. If the application requirements or technical properties of the BE.. safety brake change, project planning and a check of the application limits must be performed again.
 - It is not permitted to retrofit the BE.. safety brake or to replace an existing BE.. brake with a BE.. safety brake.
 - The BE.. safety brake must not be exposed to the following substances/conditions:
 - Oils
 - Acids
 - Gases
 - Vapors
 - Radiation
 - Motors with BE.. safety brake are not suited for operation in areas with increased vibration stress of level 1 (vibration level 1) according to DIN ISO 10816:1997-08.

3 Functional safety (FS)

3.1 Functionally safe motor options

Drives from SEW-EURODRIVE are optionally available with functionally safe motor options. These options are intended for implementation of safety functions in safety-relevant applications.

SEW-EURODRIVE assumes responsibility for the delivered drive in terms of compliance of the functionally safe motor options with the functional safety regulations. To detect deviations from the delivery state, safety-relevant connection elements are sealed.

3.1.1 Safety encoder

Safety encoders from SEW-EURODRIVE are characterized by their exceptional reliability as well as electronic and mechanical load capacity.

Safety encoders allow you to increase the safety in your machines by implementing safety functions regarding speed, direction of rotation, idle state and relative position. The safety encoder provides the safety-relevant signals in the intelligent interaction of sensor, control and actuator.

The safety function requires a reliable mechanical connection between encoder and motor. At SEW-EURODRIVE, this connection is dimensioned in such a way that fault exclusion is achieved.

The safety encoders cannot trigger a safe state at the machine autonomously. Therefore, they have to be monitored in the overall system. The overall system will trigger a suitable error response, e.g. the safe state, on request.

3.1.2 Safety brake

Safety brakes from SEW-EURODRIVE are characterized by their exceptional reliability as well as electronic and mechanical load capacity.

Safety brakes allow you to increase the safety in your machines by implementing safety functions for deceleration and stopping. The safety brake represents the safety-relevant actuator in the intelligent interaction of sensor, control and actuator.

Safety brakes from SEW-EURODRIVE already consider the following functional safety requirements according to EN ISO 13849, parts 1 and 2:

- Application of basic safety principles
- Application of proven safety principles
- Information on the characteristic safety value B_{10d}
- Common cause failure (CCF)
- Notice of influences and ambient conditions
- Determination of the category (Cat.)
- Retraceability by the unique motor assignment
- Production monitoring with 100% final inspection
- Compliance with normative requirements regarding documentation

The suitability for functional safety as well as compliance with the normative requirements is certified by TÜV Nord Systems GmbH & Co. KG. You can rely on the manufacturer confirmation (e.g. TÜV certificate) in your safety-related overall evaluation and considerably reduce efforts for evaluation and documentation of a brake.





The safety brakes cannot trigger a safe state at the machine autonomously. The brakes have to be supplemented with a suitable brake control and monitored by brake diagnostics, if necessary. The overall system triggers a suitable error response, e.g. the safe state, on request.

3.2 FS mark

Motors from SEW-EURODRIVE are optionally available with functionally safe motor options. These are designed for implementation of safety functions.

The documentation designates the respective functional safety design explicitly as safety encoder plus "type designation" or safety brake plus "type designation".

SEW-EURODRIVE labels a functionally safe motor option at the drive with an FS logo and a 2-digit number on the motor nameplate. The number is a code that indicates which components in the drive are safety-related. This allows to uniquely identify an available functionally safe motor option via the motor nameplate.

FS logo	Available functionally safe motor option		
	Decentralized in-verters	Safety brake	Safety encoder
	X		
		X	
			X
	X		X
		X	X

If the FS logo, e.g. with the code "FS-11" is present on the motor nameplate, the combination of safety encoder and safety brake is available at the motor. If an FS logo is available, adhere to the information specified in the corresponding documentation.

3.3 Retraceability

Functionally safe motor options can be retraced by SEW-EURODRIVE with the motor serial number and thus have a unique assignment to the motor.

If the SEW-EURODRIVE service replaces a safety encoder or a safety brake, the retraceability is ensured.

If you replace a functionally safe motor option on your own, you revoke this assignment. To continue the assignment, document the replacement yourself.

3.4 Underlying standards

The safety assessment of safe motor options is based on the following standards and safety classes:

Safety encoder

Add-on encoders: ES7S, EG7S, AS7W, AG7W, AS7Y, AG7Y	
Safety class/ underlying standard	<ul style="list-style-type: none"> • Safety Integrity Level (SIL) according to IEC 62061 • Performance Level (PL) according to EN ISO 13849-1
Built-in encoder: EI7C FS	
Safety class/ underlying standard	<ul style="list-style-type: none"> • Safety Integrity Level (SIL) according to EN 61800-5-2 • Performance Level (PL) according to EN ISO 13849-1

Safety brake

BE05 to BE32	
Safety class/ underlying standard	<ul style="list-style-type: none"> • Category (Cat.) according to EN ISO 13849-1

3.5 TÜV certification

The following certificate is available for the described safety brakes:

- Certificate of the TÜV NORD Systems GmbH & Co. KG

The TÜV certificate is available for download on the SEW-EURODRIVE website (www.sew-eurodrive.de).

3.6 Safety functions

3.6.1 Safety functions safety encoder

ES7S, EG7S, AS7W, AG7W, AS7Y, AG7Y add-on encoders

The following safety functions regarding speed, direction of rotation, idle state and relative position can be implemented in functionally safe systems with the sine/cosine interface of the safety encoders:

- SS1, SS2, SOS, SLS, SDI, SLI, SSR, SLS, SAR, SSM

INFORMATION



For AS7W, AG7W, AS7Y and AG7Y encoders, the absolute interface is not part of the PL d/SIL 2 approval. The absolute interface may not be solely used for implementing safety functions.

Built-in encoder EI7C FS

The following safety functions regarding speed and direction of rotation can be implemented in functionally safe systems with the HTL interface of the safety encoder:

- SS1, SLS, SDI

3.6.2 Safety functions safety brake

The implementation of a safety function with electromechanical brakes requires that the brake is applied on request. The safety function is activated when the brake is applied. The brake coil has to be de-energized and the energy stored in the brake coil reduced.

You implement the following safety functions with a safe brake system (SBS):

- SBA
- SBH

INFORMATION



Safety functions SBA and SBH are defined by SEW-EURDRIVE in accordance with the standard EN 61800-5-2.

The implementation of the SBA and SBH safety functions additionally require the safety functions SBC and STO in the overall system. For safety-related requests of the brake, SBC and STO ensure that the brake applies and that the drive does not generate a torque against the applied brake.

The SBC and STO safety functions are not part of the brake and have to be additionally implemented in the overall safety system. The performance level (PL) of the SBC and STO safety functions must at least meet the required performance level (PLr) of the application.

SEW-EURODRIVE recommends to stop the drive using the stop category 1 according to EN 60204-1 prior to activating the SBC and STO safety functions.

3.7 Requirements to the follow-up electronics

3.7.1 Add-on encoders: ES7S, EG7S, AS7W, AG7W, AS7Y, AG7Y

The monitoring of the sine/cosine signals for detecting the safe state is performed by the follow-up electronics. The follow-up electronics has to check the sine/cosine signals of the rotary encoder for validity. For safety-related use of the encoders, the following requirements have to be fulfilled by the follow-up electronics:

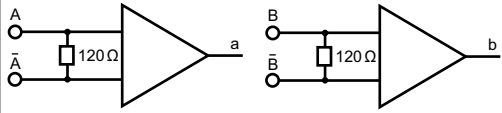
Name	Requirement
Safety requirements	≥ SIL 2
Diagnostics coverage (DC)	≥ 90%
Error presumptions	According to EN 61800-5-2:2016, table D.8
Monitoring of the phasor length "r"	$r = \sqrt{a^2 + b^2}$ with a = A – \bar{A} for cosine signals and b = B – \bar{B} for sine signals
Safe state	Phasor length "r" outside of the range $350 \text{ mV} \leq r \leq 700 \text{ mV}$
Terminating resistor between A and \bar{A} or B and \bar{B}	$120 \Omega \pm 10\%$ 
Terminating resistor between A, \bar{A} , B, \bar{B} to the supply voltage and reference ground	> 1 kΩ
Scanning frequency	At least twice as high as the frequency maximally occurring in the application at the encoder signal outputs (Nyquist criterion)

If the safety encoders are connected with prefabricated encoder cables from SEW-EURODRIVE to the follow-up electronics from SEW-EURODRIVE, these requirements have been met.

3.7.2 Integrated encoders: EI7C FS

Operating the EI7C FS built-in encoder at encoder evaluation units of other manufacturers is not permitted. Observe the corresponding manuals. The built-in encoder is intended for operation with functionally safe encoder evaluation units from SEW-EURODRIVE, e.g. safety option S12.

23480866/EN – 05/2017

3.8 Brake diagnostics

Brake diagnostics is required according to EN ISO 13849-1 depending on the required Performance Level. The diagnostic coverage (DC_{avg} value) must meet the regulatory requirements. Brake diagnostics provides additional information for the user regarding the state and performance of the brake. This allows you to detect potential errors in time and initiate maintenance/repair.

Brake diagnostics must detect the following possible failures separately for each brake:

- Brake is not applied.
- Insufficient braking torque.

To prevent faulty diagnostic results, SEW-EURODRIVE recommends to additionally diagnose the potential failure "Brake does not release".

Brake diagnostics is not part of the brake and must be implemented within the system. SEW-EURODRIVE offers the brake diagnostics solution as software for the controller of the performance classes advanced/power. Brake diagnostics fulfills the regulatory requirements and allows for performance level e (PL e).

3.9 Motor combinations

3.9.1 Safety encoders

The safety encoders described below are intended for use with DR.., DRN.., EDRN.. motors. It is not permitted to mount them to other motors.

Safety encoders at the DR.., DRN.. AC motor

Motors	Encoders	Part number	
		Without	With
		Connection cover	
DR..71 – DR..132 DRN80 – DRN132S	ES7S	13642715	13642898
	AS7W	13630768	13630776
	AS7Y	13630784	13630792
DR..160 – DR..280 DRN132M – DRN280	EG7S	13642782	13642952
	AG7W	13630849	13630857
	AG7Y	13630865	13630873
Motors	Encoder	Part number	
DR..71 – DR..132 DRN80 – DRN132S	EI7C FS	Ordering with part number not possible	

Safety encoders at the EDRN.. explosion-proof AC motor

Motors	Encoder	Part number	
		Without	With
		Connection cover	
EDRN80 – EDRN132S	ES7S	13642715	13642898
EDRN132M – EDRN280	EG7S	13642782	13642952

3

Functional safety (FS)

Motor combinations

3.9.2 Safety brake

Motor combinations with BE.. brake

Depending on the demands placed on the brake, different brake mounting sizes are available for mounting to the respective motor.

The following table shows the possible motor and brake combinations:

DR.. EDR..	71	80	-	90 100	112 132	160	180	200 225	250 280	315
DRN.. EDRN..	-	80	90	100	112 132S	132M 132L	160 180	200 225	250 280	315
BE05	X	X	X							
BE1	X	X	X	X						
BE2		X	X	X						
BE5			X	X	X					
BE11					X	X				
BE20						X	X			
BE30							X	X		
BE32							X	X		
BE60								X	X	
BE62								X	X	
BE120									X	X
BE122									X	X



Design not available as safety brake.

Design for DR../DRN.. optionally also available as safety brake.

Braking torque graduations

Depending on the demands placed on the brake, different braking torque graduations are available depending on the brake sizes.

The following table shows the available graduations:

Brake (M_{Bmax})	BE05 (5 Nm)	BE1 (10 Nm)	BE2 (20 Nm)	BE5 (55 Nm)	BE11 (110 Nm)	BE20 (200 Nm)
Available stages for M_B						
1.8	X					
2.5	X					
3.5	X					
5	X	X				
7		X	X			
10		X	X			
14			X	X		
20			X	X	X	
28				X	X	
40				X	X	X
55				X	X	X
80					X	X
110					X	X
150						X
200						X

Brake (M_{Bmax})	BE30 (300 Nm)	BE32 (600 Nm)
Available stages for M_B		
75	X	
100	X	X
150	X	X
200	X	X
300	X	X
400		X
500		X
600		X

X	Available
	Not available for BE.. safety brake.

INFORMATION



Note that for the BE.. safety brake, some of the reduced braking torque steps are not available in combination with the manual brake release option. It may be necessary to contact SEW-EURODRIVE.

3.10 Validation

The system manufacturer has to perform an overall evaluation for determining the safety of a machine.

The effectiveness of each risk minimization must be checked. It must also be checked if the required safety integrity (SIL and/or PL) is reached for each implemented safety function.

4 Motor structure

4.1 Nameplates

4.1.1 Motor

The following figure shows an example motor nameplate with FS logo:

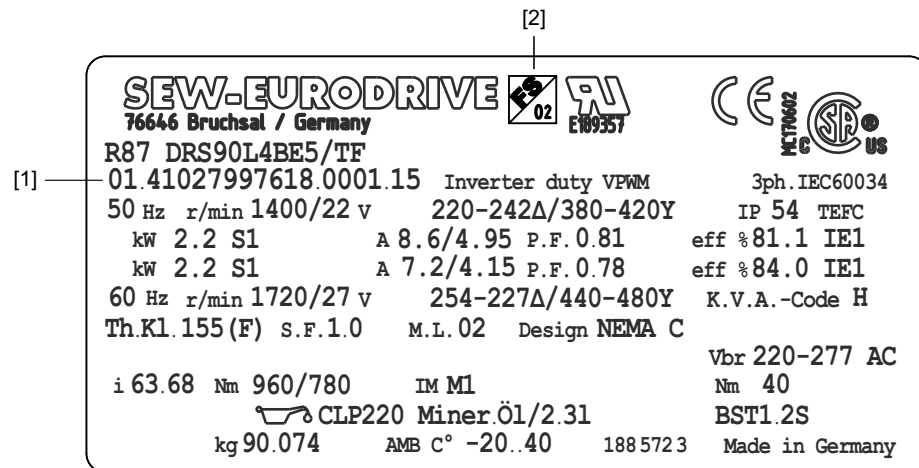

36028799560131851

- [1] Motor serial number
- [2] FS logo for functional safety

4.1.2 Safety encoder

The following figure shows an example encoder nameplate of a safety encoder:

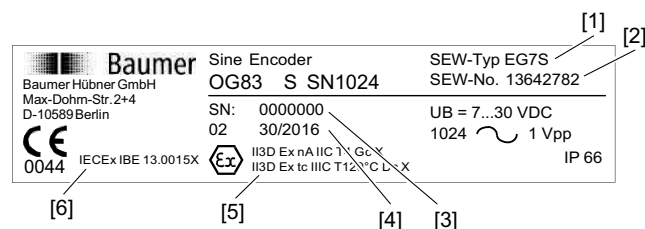

20389449739

- [1] Type designation
- [2] Part number
- [3] Serial number
- [4] Date of production. Example 30/2016: Production in calendar week 30 in the year 2016
- [5] IECEx information
- [6] IECEx certificate number

The nameplate of a safety encoder does not show an FS logo. The design for functional safety has to be identified using the motor nameplate, see chapter "FS mark" (→ 10).

4 Motor structure

Nameplates

4.1.3 Safety brake

The following figure shows an example self-adhesive label of a safety brake with FS logo:



- [1] Identification number of the brake:
- 0001.: Plant
 - 123456789012.: Serial number of the brake
 - 160112: Date of production (DDMMYY)
- [2] Assembly order number
- [3] Brake and brake size
- [4] Data matrix
- [5] FS logo

5 Mechanical installation

NOTICE

Improperly carried out work on functionally safe motor options.

Loss of the safety function.

- ✓ Improperly carried out work on functionally safe motor options can result in loss of the motor options' safety functions. This can cause injuries and damages.
- Only qualified personnel is allowed to carry out work on functionally safe motor options.
- Carry out any work on functionally safe motor options by observing the specifications in the corresponding documentation.

INFORMATION



Note that greases and oils must not be allowed on the mechanical connections of the safety components during assembly or operation.

5.1 Manual brake release

If the manual brake release was ordered, the manual brake release is installed and set at the factory.

INFORMATION



The brake option manual brake release /HF is not permitted and must not be retrofitted.

The manual brake release /HR must not be retrofitted, see corresponding operating instructions.

6 Electrical installation

NOTICE

Improperly carried out work on functionally safe motor options.

Loss of the safety function.

- ✓ Improperly carried out work on functionally safe motor options can result in loss of the motor options' safety functions. This can cause injuries and damages.
- Only qualified personnel is allowed to carry out work on functionally safe motor options.
- Carry out any work on functionally safe motor options by observing the specifications in the corresponding documentation.

INFORMATION



SEW-EURODRIVE recommends using prefabricated cables from SEW-EURODRIVE to connect the safety encoders.

6.1 Connecting the EI7C FS encoder

There is an 8-pin M12 plug connector on the terminal box for connection.

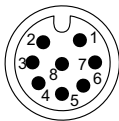
M12 AVRE				
male, A-coded	Pin 1:	+U _B	Pin 5:	B
	Pin 2:	GND	Pin 6:	\bar{B}
	Pin 3:	A	Pin 7:	nc
	Pin 4:	\bar{A}	Pin 8:	nc

INFORMATION



Pins 7 and 8 must **not** be used.

The encoder cable must meet the following requirements:

- Maximum cable length: 100 m. The cable length may be limited by the encoder evaluation unit.
- Minimum core cross section: 0,25 mm².
- The cable must be shielded. The shield must be connected over a large surface area at both ends.
- The cable must have twisted-pair conductors.

6.2 E17C FS visual feedback

The LED display, which is visible when the fan guard is removed, provides visual feedback about the signal track state.

A red LED and a green LED are used as a status display for the E17C FS safety encoder.

- The **green** LED indicates the current status.
- The **red** LED is used to display the error history by means of a flash code.

The error history always displays the most recent errors since the last time the encoder was switched on.

6.2.1 Indicating the normal state

During normal operation, the green status LED lights up constantly. Usually, no error has occurred and the red error history LED is off. If an error already occurred before the current normal operating state, this is indicated by the flash code on the red LED described below.

6.2.2 Indicating an internal diagnostics error

The E17C FS encoder has a self-diagnostics system. If this diagnostics system has an error, the encoder enters an error status. The error can be reset by switching off the supply voltage and then switching it back on.

6.2.3 Indicating service mode

If the encoder is supplied with a defined voltage range below the regular supply voltage range during startup, the encoder automatically goes into service mode. The output drivers are switched off. The red error history LED indicates service mode by lighting up constantly. The green status LED reports the distance between the encoder module and the fan wheel.

Any service work necessary on the encoder may only be performed by SEW-EURODRIVE employees.

6.2.4 Indicating error statuses

The start of an error code is indicated by a long pulse (START). The number of brief flash pulses indicates the most recent error since the encoder was switched on. The long START signal does not count as part of this number. The figure shows the structure of the flash code. The "Normal operation" (→ 24) table provides an overview of possible error statuses and the defined LED signals for these statuses.

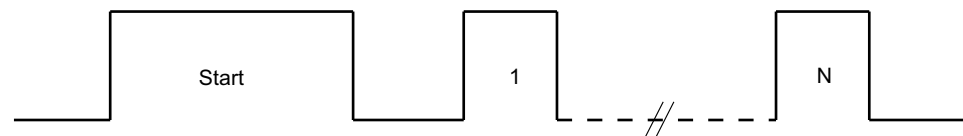

8411052555

6.2.5 LED codes for the operating statuses

Normal operation

Displayed status	Green LED (status)	Red LED (error)
No voltage or defective	OFF	OFF
Internal diagnostics error	ON	ON
No error	ON	OFF
No errors at the moment. Most recent error is displayed.	ON	Error code
An error has occurred. Most recent error is displayed.	OFF	Error code
	Temperature error	1×
	Supply voltage error	2×
	Analog signal error	3×
	Error in digital track A or B	4×
	Distance difference error	5×
	Output driver error	6×

Service operation/setup mode

Status	Meaning	Green LED	Red LED
Service operation/setup mode	Amplitude OK	OFF	ON
(Defined voltage range while switching on)	Amplitude is too high	Flashes (approx. 2 Hz)	ON
	Amplitude is too low	Flashes (approx. 0.5 Hz)	ON

6.3 Temperature sensor /TF

If you use a safety brake, you must also use and evaluate the temperature sensor /TF.

INFORMATION

If several motors with safety brake are operated with one frequency inverter (multi-motor operation), an external switching device for monitoring the temperature sensor /TF is necessary.

6.4 Brake control

The brake is released electrically. The brake applies after the voltage is switched off. The braking or stopping takes place mechanically.

These voltage disconnection types are distinguished:

- Functional control
Control of the brake outside functional safety.
- Safe control
Control of the brake for the use in functional safety.

6.5 Permitted brake controls

The supply of the safety brake must be achieved by a brake control. There are several designs for this purpose which are either designated for installation in the motor wiring space or for installation in the control cabinet. The following supply types are **not permitted** for BE.. safety brake:

- Operation without brake control (DC direct voltage supply)
- Operation with third-party control
- Supply via motor terminal board (direct wiring)

For permitted brake controls, refer to chapter "Technical data" (→ 47). Connection may only be performed according to the valid wiring diagram enclosed.

7 Inspection/maintenance

NOTICE

Improperly carried out work on functionally safe motor options.

Loss of the safety function.

- ✓ Improperly carried out work on functionally safe motor options can result in loss of the motor options' safety functions. This can cause injuries and damages.
- Only qualified personnel is allowed to carry out work on functionally safe motor options.
- Carry out any work on functionally safe motor options by observing the specifications in the corresponding documentation.

7.1 Safety encoder

Certain demands on the mechanical coupling of the encoder system to the motor must be met so that the encoder can be used for safety-relevant tasks.

With the EI7C FS built-in encoder, no work may be performed on the encoder. Order the SEW-EURODRIVE service to perform any necessary work on the encoder.

There are the following options for performing work on the ES7S, EG7S, AS7W, AS7Y, AG7W, AG7Y encoders or the motor during which the sealed screw connections must be opened:

- Order the SEW-EURODRIVE service to perform this work.
- You perform the work yourself.

Note that all work on the safety encoder and its mechanical coupling is carried out at your own risk. The operator is responsible and liable for the proper fulfillment of the work. The operator has to ensure the traceability of the performed changes regarding functional safety. In case of proven compliance with the activities described in the operating instructions, the characteristics regarding functional safety described by the manufacturer are maintained.

7.2 Removing/installing the encoder

INFORMATION



When installing an encoder, observe the tightening torques specified in this documentation to avoid a faulty mechanical connection between the drive component and the rotary encoder according to EN 61800-5-2.

7.2.1 Required tools

You need the following tools to assemble and disassemble the encoders. Make sure that all the tools are available before you remove/install an encoder.

- New expansion anchor [362]. The expansion anchor can be ordered from SEW-EURODRIVE with the part number 13617311 (for ES7S, AS7W, and AS7Y encoders).
- Compound against contact corrosion, such as NOCO[®] fluid
- Various sizes of hollow hexagon wrenches
- Various sizes of external hexagon wrenches
- Torque wrench for tightening torques of 2.0 Nm to 8.0 Nm
- Sensor with a measuring range of 1/100 mm for measuring the wobble

7.2.2 Removing/installing the encoder from DR..71 – 132, DRN80 – 132S

The following figure illustrates the disassembly procedure using the ES7. encoder as an example:

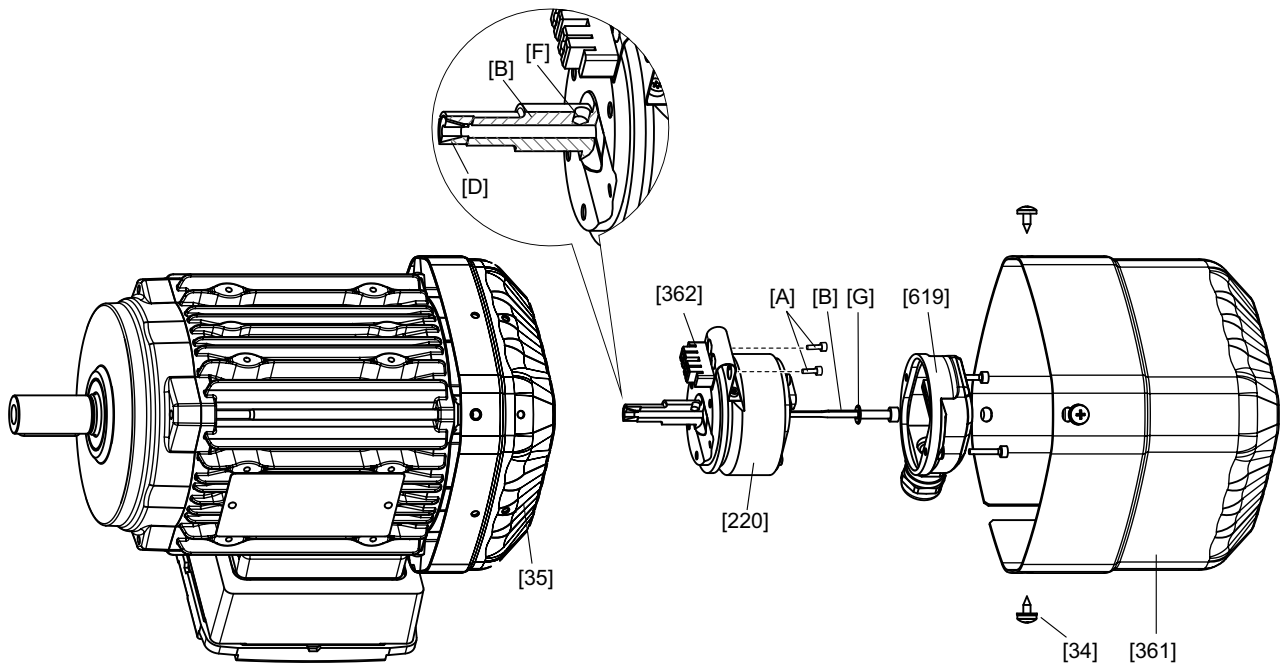

2583101195

[34] Tapping screw

[35] Fan guard

[220] Encoder

[361] Safety cover

[362] Expansion anchor

[619] Connection cover

[A] Retaining screws for the torque arm

[B] Central retaining screw

[D] Cone

[F] Bore

[G] Tooth lock washer

Disassembling ES7./AS7.

1. Remove safety cover [361] and forced cooling fan, if available.
2. Unscrew and remove the connection cover [619]. Do not disconnect the encoder connection cable.
3. Loosen the expansion anchor [362] by removing the screws [A] from the cover grid.
Dispose of the expansion anchor.
4. Unscrew the central retaining screw [B] by about 2 to 3 turns (do not remove) and unfasten the cone [D] of the spread shaft by tapping lightly on the bolt head.
5. Pull the encoder [220] from the rotor bore.

If the encoder is hard to loosen, you can loosen or counterhold the encoder shaft at the bore [F].

Re-assembly

1. Apply a contact corrosion prevention compound, e.g. NOCO[®] fluid to the encoder pin.
2. Install the tooth lock washer [G] and tighten the central retaining screw [B] with a tightening torque of $2.75 \text{ Nm} \pm 5\%$.
 - You must tighten the central retaining screw with the specified tightening torque.
3. Press the expansion anchor into the fan guard and make sure that it is fitted properly.

Always use a new expansion anchor when re-assembling the system.
4. Screw the retaining screws [A] of the torque arm [362] into the expansion anchor all the way and tighten it with a tightening torque of $2.25 \text{ Nm} \pm 10\%$.
 - You must tighten the retaining screws for the torque arm with the specified tightening torque.
5. Perform the wobble measurement according to chapter "Measuring wobbling" (→ 32).
6. Fasten connection cover [619] with a tightening torque of $2.25 \text{ Nm} \pm 10\%$.
7. Install the forced cooling fan, if necessary.
8. Install the safety cover [361].

7.2.3 Removing/installing the encoder from DR..150 – 280, DRN132M – 280

The following figure illustrates the disassembly procedure using the EG7. encoder as an example:

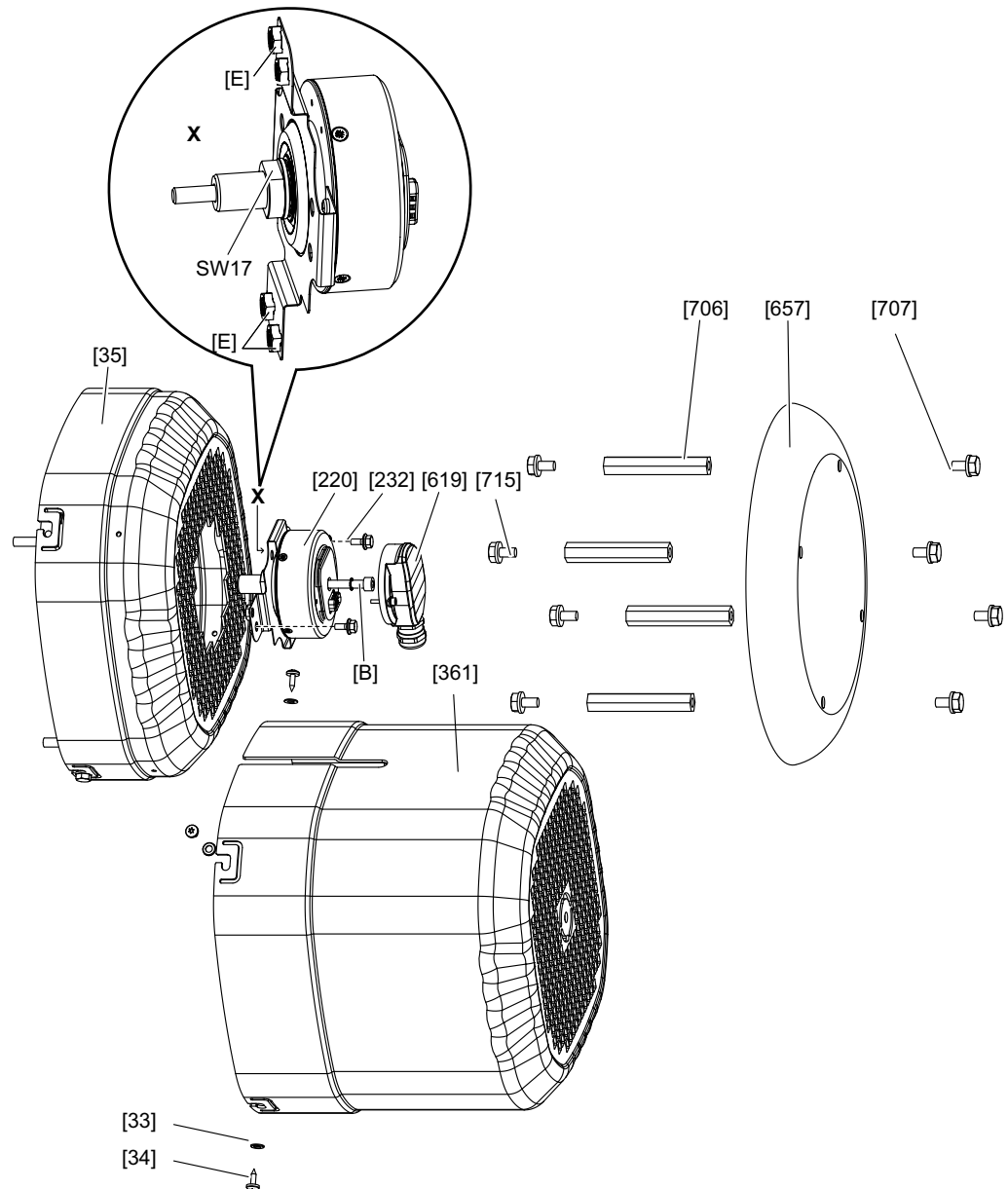

2583097355

[33]	Washer	[657]	Canopy
[34]	Tapping screw	[706]	Spacer bolt
[35]	Fan guard	[707]	Hex head screws
[220]	Encoder	[715]	Hex head screws
[232]	Retaining screws for the torque arm	[B]	Central retaining screw
[361]	Safety cover	[E]	Nuts
[619]	Connection cover		

Disassembling EG7./AG7.

1. Depending on the housing design, perform one of the following steps:
 - Loosen the screws [707] and remove the canopy [657].
Use SW13 spacer bolts [706] to counterhold.
Remove forced cooling fan, if installed.
 - Loosen the screws [34] and remove the safety cover [361].
Remove forced cooling fan, if installed.
2. Unscrew and remove the connection cover [619].
3. Unscrew screws [232].
4. Remove the fan guard [35].
5. Push off the encoder [220] by loosening the central retaining screw [B].
If the encoder is hard to loosen, you can loosen or counterhold the encoder shaft at the installed SW17 spanner flat.

Re-assembly

1. Apply a contact corrosion prevention compound, e.g. NOCO® fluid to the encoder shaft.
2. Apply the encoder in the rotor bore and screw it in with the central retaining screw [B] all the way and tighten the screw with a tightening torque of $8 \text{ Nm} \pm 5\%$.
 - You must tighten the central retaining screw with the specified tightening torque.
3. Clean the threads of the retaining screws in the torque arm [232] to remove remnants of the old thread locking compound.
4. Apply a medium thread locking compound, e.g. LOCTITE® 241, to the 2 screws [232] and screw the torque plate of the encoder to the fan grille with a tightening torque of $6 \text{ Nm} \pm 10\%$.
 - You must tighten the retaining screws for the torque arm with the specified tightening torque.
5. Perform the wobble measurement according to chapter "Measuring wobbling" (→  32).
6. Mount connection cover [619] with a tightening torque of $2.25 \text{ Nm} \pm 10\%$.
7. Install the forced cooling fan, if necessary.
8. Install the canopy [657] with the screws [707], or install the safety cover [361] with the screws [34].

7.3 Measuring wobbling

Fault exclusion of the mechanical motor-encoder connection according to EN 61800-5-2 requires that the encoder is seated properly. Wobbling must be measured each time an encoder is installed to ensure it is seated properly.

Measure wobbling as described in the following chapters.

7.3.1 Encoders for DR..71 – 132, DRN80 – 132S

1. Place the sensor on the upper edge of the encoder as shown in the figure below:

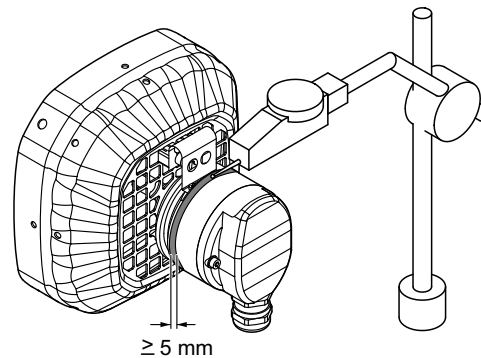

9007203225200139

2. The measurement must be carried out within the marked zone (maximum width = 5 mm).
3. Turn the motor shaft. If required, start up the motor at low speed ($< 60 \text{ min}^{-1}$).
4. Check the wobble on the sensor. The maximum permitted wobble on the rotary encoder must be $\leq 0.07 \text{ mm}$ when turning the motor shaft.

Repeat the test if the measured value is exceeded. To do so, proceed as follows:

5. Remove the central retaining screw [B] and and loosen the cone [D] by tapping lightly on the head of the retaining screw [B].
6. Turn the motor shaft or the encoder shaft at the bore [F] by 120° .
7. Tighten the central retaining screw [B] as described in chapter "Removing/ installing the encoder" (\rightarrow 27).
8. Repeat the wobble measurement.

INFORMATION



If it is not possible to carry out the measurement below the permitted wobble, please contact the SEW-EURODRIVE service.

7.3.2 Encoders for DR..160 – 280, DRN132M – 280

1. Place the sensor on the upper edge of the encoder as shown in the figure below:

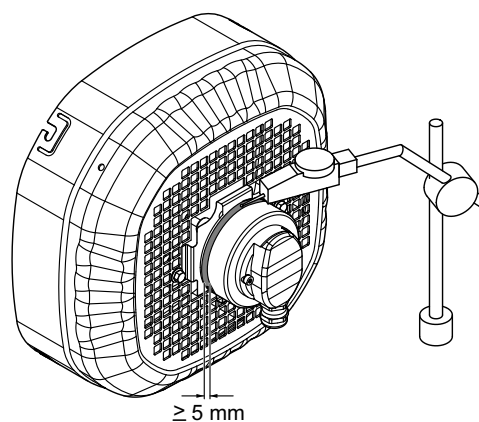

9007203226345867

2. The measurement must be carried out within the marked zone (maximum width = 5 mm).
3. Turn the motor shaft. If required, start up the motor at low speed ($< 60 \text{ min}^{-1}$).
4. Check the wobble on the sensor. The maximum permitted wobble on the rotary encoder must be $\leq 0.1 \text{ mm}$ when turning the motor shaft.

Repeat the check if the maximum permitted value is exceeded. To do so, proceed as follows:

5. Remove the encoder as described in chapter "Removing/installing the encoder" (\rightarrow 27).
6. Turn the motor shaft or the encoder shaft at the SW17 spanner flat installed at the encoder by 120° .
7. Install the encoder as described in chapter "Removing/installing the encoder" (\rightarrow 27).
8. Repeat the wobble measurement.

INFORMATION



If it is not possible to carry out the measurement below the permitted wobble, please contact the SEW-EURODRIVE service.

7.4 Inspection and maintenance intervals

Inspect and service the safety brake according to the projected inspection and maintenance intervals or every 0.5 to 2 years depending on the load conditions.

If a diagnostic unit /DUE is used, the wear output of the evaluation unit indicates whether brake maintenance is required. You may use the analog signal which is proportional to the air gap to plan brake maintenance.

INFORMATION



The amount of wear depends on many factors and may therefore be high. The system manufacturer must determine the required inspection/maintenance intervals individually in accordance with the project planning documents.

7.5 Safety brake

NOTICE

Improperly carried out work or changes to the technical properties on functionally safe motor options.

Loss of the safety function.

- ✓ Improperly carried out work on functionally safe motor options or changes to the technical properties can result in loss of the motor options' safety functions. This can cause injuries and damages.
- Only qualified personnel is allowed to carry out work on functionally safe motor options.
- Carry out any work on functionally safe motor options by observing the specifications in the corresponding documentation.

INFORMATION



SEW-EURODRIVE recommends ordering the SEW-EURODRIVE service to carry out the maintenance work.

If you perform maintenance work yourself, the responsibility and the liability for the proper fulfillment of the work described in the relevant documentation is passed to the user, see chapter "Functional safety" (→ 6).

Type of work	Work permitted?	Comments
Replace safety brake.	Yes	Replacement with structurally identical safety brake incl. options. Deviating product designs require a check of the configuration as well as the suitability for the relevant application.
Replace existing BE.. brake with BE.. safety brake.	No	Contact SEW-EURODRIVE.
Change the braking torque.	Yes	Replacement of safety brake necessary.
Check and correct air gap, if necessary.	Yes	– Observe minimum permitted brake disk thickness. See chapter "Working air gap" (→ 52).
Replace individual parts of the BE.. safety brake.	Yes	Replacement of the following individual parts is permitted: <ul style="list-style-type: none"> • Sealing strip [66] • Clamping strap [157], if necessary • Sealing ring [95] • Hex nut [61]
Replace driver.	Yes	–

23480866/EN – 05/2017

Type of work	Work permitted?	Comments
Retrofit manual brake release /HR.	No	Contact SEW-EURODRIVE.
Replace manual brake release /HR.	Yes	–
Retrofit diagnostic unit /DUE.	Yes	Replacement of safety brake necessary.
Replace diagnostic unit / DUE.	Yes	–
Retrofit brake monitoring / DUB.	Yes	Replacement of safety brake necessary.
Replace brake monitoring / DUB.	Yes	–
Set brake monitoring /DUB (switching point).	Yes	–

INFORMATION



For all numbers of spare parts needed during maintenance work, refer to the respective exploded view drawings in relevant operating instructions.

7.6 Preliminary work for motor and brake maintenance

7.6.1 General information

Proceed as described in the respective documentation to remove and install the encoder/safety encoder and/or forced cooling fan.

Before you complete the maintenance work, restore all protection devices at the drive.

INFORMATION



Observe the following points for inspection and maintenance:

- When replacing the safety brake due to a defect of the brake coil, always replace the brake control as well.
- Observe the information in the respective operating instructions.

7.6.2 Wearing parts

NOTICE

Use of incorrect wear parts or a brake differing from the original.

Loss of the safety function.

- Replace the brake only with an identical brake including all options as delivered from SEW-EURODRIVE.

If the brake is replaced, replace the following wear parts:

- Screws [900] (only DR..90 – 225, DRN90 – 225)
- Gasket [392] (only DR.71 – 80)
- Sealing ring [95]
- O-ring [901] (only DR..160 – 225, DRN132M – 225)
- Gasket [901] (only DR..90 – 132, DRN90 – 312S)
- Motor tie rods [13] (only DR..71 – 80, DRN80)

In case of visible wear or damage of the driver, replace the following parts:

- Driver [70]
- Key [71]
- Retaining ring [62]

Order the wear parts from SEW-EURODRIVE prior to the brake replacement.

INFORMATION



To order the correct design of the brake and the wear parts, the item number of the spare and/or wearing parts and the serial number of the drive (see motor nameplate) is required.

7.6.3 Order information for operating supplies and auxiliary material for maintenance

The following sections lists the various operating supplies and auxiliary materials that are required for correct maintenance.

Use	Manufacturer	Operating supply/auxiliary material	Part number	Quantity	Place of use	Motors
Sealing compound	Marston-Domstel	SEW-L-Spezial	09112286	80 g	80 g80 g[550]	All designs
Thread locking compound	Henkel	Loctite 241	On request	–	[13]	DR..71 – 80, DRN80
					[900]	DR..90 – 160, DRN90 – 132L
		Loctite 243	On request	–	[900]	DR..180 – 225 DRN160 – 225
Anti-corrosion agent	SEW-EURODRIVE	NOCO® fluid	09107819	5.5 g	[70]	All designs

For lubrication of the oil seals at the motor and the motor rolling bearings, observe the "DR..71 – 315, DRN80 – 315" operating instructions.

7.6.4 Identification of safety encoder

If the drive is equipped with an encoder, you must remove it prior to the motor and brake maintenance.

Please note that the work steps for an encoder with safety technology (safety encoder) differ from an encoder without safety technology (standard encoder).

For this reason, check the FS logo on the motor nameplate, to find out if it is a safety encoder and observe the corresponding documentation:

- **Drive with safety encoder** = FS 04, FS 07, FS 11

Proceed as described in this addendum to the operating instructions to remove and install the encoder.

7.7 Inspection steps for DR..71 – 225, DRN80 – 225 brakemotors



▲ WARNING

Risk of crushing if the hoist falls or in the event of uncontrolled unit behavior.

Severe or fatal injuries.

- Secure or lower the hoist drives.
- Secure and/or fence in the driven machine.
- Before you start working on the unit, disconnect the motor and all connected options from the power supply.
- Secure the motor against unintended power-up.
- Use only genuine spare parts in accordance with the valid spare parts list.
- Always replace the brake coil together with the brake control.



INFORMATION

If the drive is equipped with corrosion and surface preventive measures, you must reestablish those measures after any work on the drive.

1. Remove fan guard, forced cooling fan and encoder, if installed. Identify first if a safety encoder is present. Refer to chapter "Identification of safety encoder" (→ 38) for further information.
2. Push the sealing strip [66] aside. Loosen the clamping straps [157] if required.
3. Measure the working air gap A at the brake according to the following figure (using a feeler gauge at three points offset by approx. 120°). Gather the correct values from chapter "Work done, working air gap, braking torques of the safety brakes" (→ 52). If the correct value for the working air gap is exceeded or too low, correct it according to the documentation or contact the SEW-EURODRIVE service to correctly set the working air gap. The hex nuts [61] may not be completely removed when the working air gap is reset.

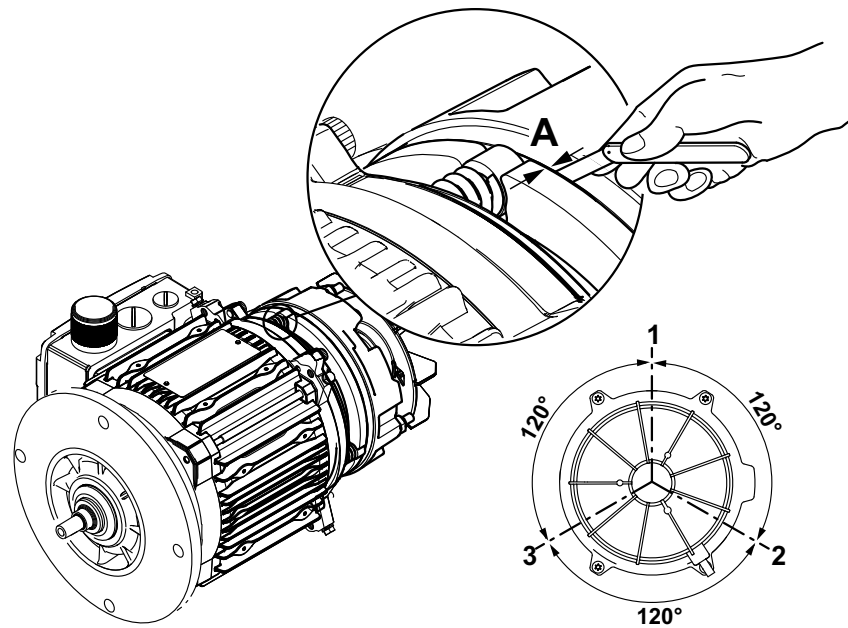

18014398689460619

4. Remove abrasion from the brake.
5. Install the sealing strip [66] and clamping strap [157], if necessary
6. Install the fan guard with encoder mount or fan guard [35] and the forced cooling fan [170].
7. Reinstall the removed parts.

7.8 Work steps for brake replacement



▲ WARNING

Risk of crushing if the hoist falls or in the event of uncontrolled unit behavior.

Severe or fatal injuries.

- Secure or lower the hoist drives.
- Secure and/or fence in the driven machine.
- Before you start working on the unit, disconnect the motor and all connected options from the power supply.
- Secure the motor against unintended power-up.
- Use only genuine spare parts in accordance with the valid spare parts list.
- Always replace the brake coil together with the brake control.

1. Remove forced cooling fan and encoder, if installed. Identify first if a safety encoder is present. Refer to chapter "Identification of safety encoder" (→ 38) for further information.
2. Remove the fan guard with encoder mount or fan guard [35], retaining ring [32] and fan [36].
3. Proceed as described in the following chapters for the corresponding motor size.
4. For diagnostic unit option /DUE: Loosen the screw fitting of the sensor [1151] at the monitoring unit /DUE at the magnet body of the brake [54] and remove sensor, loosen cable fixation at the magnet body [1152/1153], if necessary. Do **not** loosen the connection at the evaluation unit [1756] in the terminal box.

7.8.1 DR..71 – 80, DRN80

1. Remove the terminal box cover and loosen the brake cable from the brake control/ terminals. If necessary, attach trailing wire to brake cables.
2. Loosen cap screws [13] and remove brake endshield with brake [550] from stator [1].
3. Replace gasket [392].
4. Replace retaining ring [62], driver [70] and key [71], if necessary.
5. Insert the brake cable of the new brake into the terminal box.
6. Install the new brake, observing the alignment of the cams of the brake endshield.
 - For designs with corrosion protection /KS and/or IP56/66, the clamping straps of the disassembled brake have to be mounted to the new brake [550]. Seal studs with SEW-L-Spezial, see chapter "Order information for operating supplies and auxiliary material for maintenance" (→ 38).
7. Reseal the shaft:
 - Replace sealing ring [95] (not for brakes with manual brake release /HR)
Apply grease to the sealing lip (see chapter "Order information for lubricants and anti-corrosion agents" in the corresponding operating instructions).
8. Assemble the brake [550] and connect the brake cables.
9. The retaining screws [13] must be tightened with the tightening torques listed below and secured with Loctite® thread locking compound.

Motor size	Screw	Tightening torque ¹⁾	Loctite®
		Nm	
DR..71 – 80, DRN80	M5	5	241

1) Tolerance ±10%

10. Visually check all sealing elements for correct installation.
11. For diagnostic unit option /DUE: Insert sensor [1151] into the magnet body [54] of the new brake by using the screw fitting. Fasten the cable with terminal [1152/1153] at the magnet body in a way that the sensor cable cannot touch the fan wheel [36]. Perform zero value calibration according to the corresponding operating instructions.
12. Install the motor and accessory equipment.

7.8.2 DR..90 – 132, DRN90 – 132S

1. Remove the terminal box cover and loosen the brake cable from the brake control/ terminals.
2. Loosen screws [900] and remove brake [550] from brake endshield.
3. Replace retaining ring [62], driver [70] and key [71], if necessary.
4. Replace gasket [901] and ensure correct alignment of the gasket.
5. Insert the brake cable of the new brake into the terminal box.
6. Install the new brake, observing the alignment of the cams of the friction disk.
 - For designs with corrosion protection /KS and/or IP56/66, the clamping straps of the disassembled brake have to be mounted to the new brake [550]. Seal studs with SEW-L-Spezial, see chapter "Order information for operating supplies and auxiliary material for maintenance" (→ 38).
7. Reseal the shaft:
 - Replace sealing ring [95] (not for brakes with manual brake release /HR)
Apply grease to the sealing lip (see chapter "Order information for lubricants and anti-corrosion agents" in the corresponding operating instructions).
8. Assemble the brake [550] and connect the brake cables.
9. The retaining screws [900] must be tightened with the tightening torques listed below and secured with Loctite® thread locking compound.

Motor size	Screw	Tightening torque ¹⁾	Loctite®
		Nm	
DR..90 – 100, DRN90 – 100	M6	10.3	241
DR..112 – 132, DRN112 – 132S	M8	25.5	241

1) Tolerance ±10%

10. Visually check all sealing elements for correct installation.
11. For diagnostic unit option /DUE: Insert sensor [1151] into the magnet body [54] of the new brake by using the screw fitting. Fasten the cable with terminal [1152/1153] at the magnet body in a way that the sensor cable cannot touch the fan wheel [36]. Perform zero value calibration according to the corresponding operating instructions.
12. Install the motor and accessory equipment.

23480866/EN – 05/2017

7.8.3 DR..160 – 225, DRN132M – 225

1. Loosen safety screws of the brake plug connector [698] and remove plug connector.
2. Loosen screws [900] and remove brake [550] from brake endshield.
3. Replace retaining ring [62], driver [70] and key [71], if necessary.
4. Replace O ring [901].
5. Install the new brake, observing the alignment of the cams of the friction disk.
 - For designs with corrosion protection /KS and/or IP56/66, the clamping straps of the disassembled brake have to be mounted to the new brake [550]. Seal studs with SEW-L-Spezial, see chapter "Order information for operating supplies and auxiliary material for maintenance" (→ 38).
6. Reseal the shaft:
 - Replace the sealing ring [95].
Apply grease to the sealing lip (see chapter "Order information for lubricants and anti-corrosion agents" in the corresponding operating instructions).
7. Reassemble brake with screw [900] on brake endshield (tightening torque: 3 Nm +/-20%) and connect the connector [698].
8. The retaining screws [900] must be tightened with the tightening torques listed below and secured with Loctite® thread locking compound.

Motor size	Screw	Tightening torque ¹⁾	Loctite®
		Nm	
DR..160, DRN132M/L	M8	25.5	241
DR..180, DRN160/180	M10	50	243
DR..200 – 225, DRN200 – 225	M12	87.3	243

1) Tolerance ±10%

9. Visually check all sealing elements for correct installation.
10. For diagnostic unit option /DUE: Insert sensor [1151] into the magnet body [54] of the new brake by using the screw fitting. Fasten the cable with terminal [1152/1153] at the magnet body in a way that the sensor cable cannot touch the fan wheel [36]. Perform zero value calibration according to the corresponding operating instructions. Also check DIP switch and calibrate infinite value, see chapter "Diagnostic unit /DUE for function and wear monitoring" (→ 45).
11. Install the motor and accessory equipment.

7.9 Diagnostic unit /DUE for function and wear monitoring

The evaluation unit has a 5-pin DIP switch that is labeled with the numbers 1 to 5. Use it to set the measuring range and the maximum permitted wear limit (maximum working air gap).

To activate the DIP switch $\triangleq 1$, push the switch upwards. To deactivate the DIP switch $\triangleq 0$, push the switch downwards.

The table in chapter "DIP switch setting values for option /DUE" (\rightarrow 46) shows the DIP switch settings of the evaluation unit for the maximum working air gap if a safety brake is present.

1. Check the set value. Correct the setting value according to the following tables, if necessary.
2. Check the setting values of the DIP switches and calibrate the infinite value again, if necessary. Refer to the corresponding operating instructions for detailed instructions.

INFORMATION



Set the DIP switch only in a de-energized state.

7.9.1 DIP switch setting values for option /DUE

The following tables show the setting values of the DIP switches the option /DUE when a BE.. safety brake is present.

S1	S2	S3	S4	S5	Wear limit	BE 1 – 2	BE5
Sensor Ø 6 mm							
0	0	0	0	0	1.2 mm		
0	0	0	0	1	1.1 mm		
0	0	0	1	0	1.0 mm		
0	0	0	1	1	0.9 mm		
0	0	1	0	0	0.8 mm		
0	0	1	0	1	0.7 mm		X
0	0	1	1	0	0.6 mm	X	
0	0	1	1	1	0.5 mm		

S1	S2	S3	S4	S5	Wear limit	BE11 – 30	BE32
Sensor Ø 8 mm							
1	0	0	0	0	1.2 mm		
1	0	0	0	1	1.1 mm		
1	0	0	1	0	1.0 mm		
1	0	0	1	1	0.9 mm		
1	0	1	0	0	0.8 mm		X
1	0	1	0	1	0.7 mm	X	
1	0	1	1	0	0.6 mm		
1	0	1	1	1	0.5 mm		

X Factory setting

Setting possible in addition

8 Technical data

8.1 Safety encoder

8.1.1 Characteristic safety values

INFORMATION



In addition to the documentation, you can also obtain the characteristic safety values of components by SEW-EURODRIVE in the SEW-EURODRIVE library for the SISTEMA software tool. The documentation as well as the library are available for download at <http://www.sew-eurodrive.de/>.

Characteristic safety values ES7S, EG7S

	Characteristic safety values according to	
	EN 62061/IEC 61508	EN ISO 13849-1
Safety class/underlying standards	SIL2	PL d
System structure	HFT = 1	2-channel (cat. 3)
PFH _d value ¹⁾ (without mounting to the motor)	8.5 x 10 ⁻⁹ 1/h = 8.5 FIT (T _A ≤ 45 °C) 1.3 x 10 ⁻⁸ 1/h = 13 FIT (T _A ≤ 60 °C)	
MTTF _d value ¹⁾ (without mounting to the motor)	–	1306 years (T _A ≤ 45 °C) 895 years (T _A ≤ 60 °C)
PFH _d value ¹⁾ (with mounting to the motor, considers a derating due to motor re-heating)	5.0 x 10 ⁻⁸ 1/h = 50 FIT (T _A ≤ 60 °C)	
MTTF _d value ¹⁾ (with mounting to the motor, considers a derating due to motor re-heating)	–	212 years (T _A ≤ 60 °C)
Service life/proof test interval	20 years	
Motor/encoder connection (only for drives with FS logo)	Fault exclusion according to EN 61800-5-2	

1) The specified values are valid if the requirements to the evaluation unit according to section "Requirements to the follow-up electronics" are adhered to.

Characteristic safety values AS7W, AG7W, AS7Y, AG7Y

	Characteristic safety values according to	
	EN 62061/IEC 61508	EN ISO 13849-1
Safety class/underlying standards	SIL2	PL d
System structure	HFT = 1	2-channel (cat. 3)
PFH _d value ¹⁾ (without mounting to the motor)	6.4 x 10 ⁻⁹ 1/h = 6.4 FIT (T _A ≤ 45 °C)	
MTTF _d value ¹⁾ (without mounting to the motor)	–	1155 years (T _A ≤ 45 °C)
PFH _d value ¹⁾ (with mounting to the motor, considers a derating due to motor re-heating)	5.0 x 10 ⁻⁸ 1/h = 50 FIT	
MTTF _d value ¹⁾ (with mounting to the motor, considers a derating due to motor re-heating)	–	212 years
Service life/proof test interval	20 years	
Motor/encoder connection (only for drives with FS logo)	Fault exclusion according to EN 61800-5-2	

1) The specified values are valid if the requirements to the evaluation unit according to section "Requirements to the follow-up electronics" are adhered to.

Characteristic safety values for EI7C FS

	Characteristic safety values according to	
	EN 61800-5-2	EN ISO 13849-1
Safety class/underlying standards	SIL 2	PL d
System structure	HFT = 0	Category 2 (cat. 2)
PFH _d value	8.0 x 10 ⁻⁸ 1/h = 80 FIT (T _A ≤ 60 °C)	
MTTF _d value	–	202 years (T _A ≤ 60 °C)
Service life/proof test interval	20 years	
Safe fault coverage (SFF)	90%	

8.1.2 Encoders

ES7S, EG7S, AS7Y, AG7Y, AS7W, AG7W

Name	Value
Operating ambient temperature for the encoder	-30 °C to +85 °C
Storage temperature	-15 °C to +70 °C
Maximum speed	6000 min ⁻¹
Vibration resistance (EN 60068-2-6)	≤100 m/s ² ≈ 10 g (at 10 Hz to 2 kHz)
Maximum angular acceleration	10 ⁴ rad/s ²
Degree of protection (EN 60529)	IP66

ES7S, EG7S

Name	Value
Operating voltage	DC +7 to +30 V
Current consumption without load	100 mA
Resolution	Sin/cos interface 1024 periods/revolution
Accuracy	0.0194 ° (70 angular seconds) ¹⁾
Shock resistance (EN 60068-2-27)	ES7S: ≤ 1000 m/s ² ≈ 100 g (6 ms) EG7S: ≤ 2000 m/s ² ≈ 200 g (6 ms)
Duration until error message ²⁾ (deactivated outputs)	25 ms

1) Due to the stiffness of the torque arm, you have to take into account an automatically resetting ± 0.6 ° twist (depending on the direction of rotation) of the encoder housing compared to the encoder shaft.

2) The ES7S and EG7S sin/cos encoders have a self-diagnostics function. If an error is detected, the sensor reports it by deactivating the output signals to the encoder evaluation unit.

AS7Y, AG7Y

Name	Value
Operating voltage	DC +7 to +30 V
Current consumption without load	100 mA
Resolution of the incremental section	Sin/cos interface 2048 periods/revolution
Accuracy of the incremental section	0.0194 ° (70 angular seconds) ¹⁾
Resolution of the absolute section	SSI interface, gray-coded 12 bit = 4096 revolutions (single-turn) 12 bit = 4096 revolutions (multi-turn)
Accuracy of the absolute section	± 1 LSB (Least Significant Bit)
Clock frequency of the absolute section	100 kHz to 800 kHz
Shock resistance (EN 60068-2-27)	AS7Y: ≤ 1000 m/s ² ≈ 100 g (6 ms) AG7Y: ≤ 2000 m/s ² ≈ 200 g (6 ms)
Duration until error message ²⁾ (deactivated outputs)	25 ms + 3/4 revolution

1) Due to the stiffness of the torque arm, you have to take into account an automatically resetting ± 0.6 ° twist (depending on the direction of rotation) of the encoder housing compared to the encoder shaft.

2) The AS7Y and AG7Y absolute encoders have a self-diagnostics function. If an error is detected, the sensor reports it by deactivating the output signals to the encoder evaluation unit.

AS7W, AG7W

Name	Value
Operating voltage	DC +7 to +30 V
Current consumption without load	100 mA
Resolution of the incremental section	Sin/cos interface 2048 periods/revolution
Accuracy of the incremental section	0.0194 ° (70 angular seconds) ¹⁾
Resolution of the absolute section	RS-485 interface 13 bit = 8192 revolutions (single-turn) 16 bit = 65536 revolutions (multi-turn)
Accuracy of the absolute section	± 1 LSB (Least Significant Bit)
Shock resistance (EN 60068-2-27)	AS7W: ≤ 1000 m/s ² ≈ 100 g (6 ms) AG7W: ≤ 2000 m/s ² ≈ 200 g (6 ms)
Duration until error message ²⁾ (deactivated outputs)	25 ms + 3/4 revolution

1) Due to the stiffness of the torque arm, you have to take into account an automatically resetting ± 0.6 ° twist (depending on the direction of rotation) of the encoder housing compared to the encoder shaft.

2) The AS7W and AG7W absolute encoders have a self-diagnostics function. If an error is detected, the sensor reports it by deactivating the output signals to the encoder evaluation unit.

EI7C FS

Supply		min.	Typ.	max.	Unit
Operating voltage ¹⁾	V_B	19.2	24	30	V
Max. current consumption (with no load)	$I_{\max} (V_B = 24 \text{ V}, I_{\text{out}} = 0)$			120	mA

1) The voltage supply must come from SELV/PELV circuits in accordance with DIN EN 61131-2

Name		Value
Max. speed	n_{\max}	$\leq 3600 \text{ min}^{-1}$
HTL periods per revolution	N_{periods}	24
Ambient temperature	T_A	0 °C to +60 °C
Vibration resistance	Acc. to EN 60068-2-6:2008	10 g (98.1 m/s ²); 5 – 2000 Hz
Shock resistance	Acc. to EN 60068-2-27:2009	100 g (981 m/s ²); 6 ms
Degree of protection	Acc. to EN 60529	IP66
Connection		M12 (8-pole)
Maximum angular acceleration		3000 rad/s ²
Permitted magnetic interference field on the outer contour of the motor	B_{extmax}	25 mT
	H_{extmax}	20 kA/m

Signal tracks		min.	Typ.	max.	Unit
Output amplitude per track	V_{high} ($I_{\text{out}} = I_{\text{out_max}}$)	$V_B - 3.5$		V_B	V
	V_{low} ($I_{\text{out}} = I_{\text{out_max}}$)	0		+3	V
Max. output current per track	$I_{\text{out_max}}$			± 30	mA
Tolerance signal period (corresponds to the speed tolerance)	$\Phi_{\text{Period.tol}}$ ($n = \text{constant}$)	-4		+4	%
Track A:B phase offset	$\Phi_{\text{Phase.A:B}}$ ($n = \text{constant}$)	70	90	110	Degree
Pulse duty factor (DIN IEC 60469-1)	$t = t_{\log_1} / (t_{\text{period}})$ ($n = \text{constant}$)	30	50	70	%
Pulse frequency for maximum speed (maximum speed × periods)	f_{\max}		1.44		kHz
Output leakage current in deactivated state (= error message) ¹⁾	I_{Error}			+250	µA
Start-up time (undefined outputs)	From $V_B > 9 \text{ V}$			300	ms
Duration until error message (deactivated outputs) ¹⁾		100		300	ms

1) The EI7C FS built-in encoder has a self-diagnostics function. If an error is detected, the system reports it by deactivating the output signals to the encoder evaluation unit.

23480866/EN – 05/2017

8.2 Safety brake

8.2.1 Braking work until maintenance

FS code	Braking work BE.. brake until inspection (W_{insp}) in 10^6 J		Braking work BE.. safety brake until inspection (W_{insp}) in 10^6 J	
	–	FS04, FS07	FS02	FS11
Brake				
BE05	120	120	120	120
BE1	120	120	120	120
BE2	180	180	180	180
BE5	390	270	270	270
BE11	640	285	285	285
BE20	1,000	445	445	445
BE30	1500	670	670	670
BE32	1500	670	670	670
BE60	2500	1100	–	–
BE62	2500	1100	–	–
BE120	390	200	–	–
BE122	390	200	–	–

8.2.2 Working air gap

BE.. safety brake	Working air gap mm		min. brake disk
	min. ¹⁾	max.	mm
BE05	0.25	0.6	11
BE1	0.25	0.6	11
BE2	0.25	0.6	11
BE5	0.25	0.7	11
BE11	0.3	0.7	12.5
BE20	0.3	0.7	12.5
BE30	0.3	0.7	12.5
BE32	0.4	0.8	12.5

1) When checking the working air gap, note: Parallelism tolerances on the brake disk may give rise to deviations of ± 0.15 mm after a test run.

8.2.3 Safety characteristics

INFORMATION



In addition to the documentation, you can also obtain the characteristic safety values of components by SEW-EURODRIVE in the SEW-EURODRIVE library for the SIS-TEMA software tool. The documentation as well as the library are available for download at <http://www.sew-eurodrive.de>.

Characteristic safety values for BE.. safety brake

	Characteristic safety values according to EN ISO 13849-1	
Classification	Category 1	
System structure	1-channel (cat. 1)	
Operating mode	High demand	
Safe state	Brake applied	
Safety functions	Safe brake actuation (SBA)	
	Safe brake hold (SBH)	
Service life	20 years or T_{10d} value (depending on which value occurs first)	
T_{10d} value	$0.1 \times \text{MTTF}_d$	
MTTF_d value	Calculation via B_{10d} value	
B_{10d} value	BE05	20×10^6
	BE1	16×10^6
	BE2	12×10^6
	BE5	10×10^6
	BE11	8×10^6
	BE20	5×10^6
	BE30	3×10^6
	BE32	3×10^6

8.2.4 Brake controls

Combinations of brake controls

The tables below show the standard and optional combinations of safety brake and brake rectifiers.

Installation in control cabinet

Type designation	Voltage range V	BE05 BE1	BE2	BE5	BE11	BE20	BE30 BE32
BST 0.6S	AC 460	X	X	X	X	X	X
BST 0.7S	AC 400	X	X	X	X	X	X
BST 1.2S	AC 230	X	X	X	X	X	X
BMS 1.4	AC 230 – 575	•	•	–	–	–	–
BMS 1.5	AC 150 – 500	•	•	–	–	–	–
BMS 3	AC 24 – 150	•	•	–	–	–	–
BME 1.4	AC 230 – 575	•	•	•	•	•	•
BME 1.5	AC 150 – 500	•	•	•	•	•	•
BME 3	AC 42 – 150	•	•	•	•	•	•
BMP 1.4	AC 230 – 575	•	•	•	•	•	•
BMP 1.5	AC 150 – 500	•	•	•	•	•	•
BMP 3	AC 42 – 150	•	•	•	•	•	•
BMK 1.4	AC 230 – 575	•	•	•	•	•	•
BMK 1.5	AC 150 – 500	•	•	•	•	•	•
BMKB 1.5	AC 150 – 500	•	•	•	•	•	•
BMK 3	AC 42 – 150	•	•	•	•	•	•
BMH 1.4	AC 230 – 575	•	•	•	•	•	•
BMH 1.5	AC 150 – 500	•	•	•	•	•	•
BMH 3	AC 42 – 150	•	•	•	•	•	•
BMV 5	DC 24	•	•	•	•	•	–

X Standard design
• Selectable
– not permitted

Installation in the motor wiring space

Type designation	Voltage range V	BE05 BE1	BE2	BE5	BE11	BE20	BE30 BE32
BG 1.4	AC 230 – 575	•	•	–	–	–	–
BG 1.5	AC 150 – 500	•	•	–	–	–	–
Size 3	AC 42 – 150	•	•	–	–	–	–
BGE 1.4	AC 230 – 575	•	•	•	•	•	•
BGE 1.5	AC 150 – 500	•	•	•	•	•	•
BGE 3	AC 42 – 150	•	•	•	•	•	•
BSG	DC 24	•	•	•	•	•	–
BS 24	DC 24	•	•	–	–	–	–

- X Standard design
- Selectable
- not permitted

9 Declaration of conformity

9.1 Safety encoder

EU Declaration of Conformity



Translation of the original text

900810810/EN

SEW-EURODRIVE GmbH & Co. KG**Ernst-Blickle-Straße 42, D-76646 Bruchsal**

declares under sole responsibility that the following products

Motors of the series	DR..
in connection with encoders of the type	ES7S / EG7S AS7W / AG7W AS7Y / AG7Y XS7S / XG7S EI7C FS
possibly in connection with	
Gear units of the series	R..; RES F.. K..; KES W.. S.. H.. VARIMOT® VARIBLOC®

are in conformity with

Machinery Directive	2006/42/EC (L 157, 09.06.2006, 24-86)
----------------------------	--

This includes the fulfillment of the protection targets for "electrical power supply" in accordance with annex I No. 1.5.1 according to the Low Voltage Directive 73/23/EEC -- Note: 2014/35/EU is currently valid.

ErP Directive	2009/125/EC (L 285, 31.10.2009, 10-35)	7)
----------------------	---	-----------

Applied harmonized standards:	EN ISO 13849-1:2015 EN 61800-5-1:2007 EN 61800-5-2:2007 EN 61800-3:2004/A1:2012 EN ISO 12100:2010 EN ISO 13857:2008 EN 60034-1:2010 EN 60034-5:2001/A1:2007 EN 60664-1:2007
--------------------------------------	--

7) Products that are covered by this Directive meet the requirements of Commission Regulation (EC) No. 640/2009 from July 22, 2009 640/2009.

Bruchsal **04.11.2016**
Place Date

Johann Soder
Managing Director Technology

a) b)

- a) Authorized representative for issuing this declaration on behalf of the manufacturer
b) Authorized representative for compiling the technical documents



Passion for Sensors

EU-Konformitätserklärung
EU Declaration of Conformity
Déclaration UE de Conformité

Wir erklären in alleiniger Verantwortung, dass die Produkte, auf die sich diese Erklärung bezieht, die grundlegenden Anforderungen der angegebenen Richtlinie(n) erfüllen und basierend auf den aufgeführten Norm(en) bewertet wurden.

We declare under our sole responsibility that the products to which the present declaration relates comply with the essential requirements of the given directive(s) and have been evaluated on the basis of the listed standard(s).

Nous déclarons sous notre seule responsabilité que les produits auxquels se réfère la présente déclaration sont conformes aux exigences essentielles de la directive/ des directives mentionnée(s) et ont été évalués sur la base de la norme/ des normes listée(s).

Hersteller
Manufacturer
Fabricant
Baumer Hübner GmbH

Bezeichnung
Description
Description
Sinus- oder Absolutgeber ohne Erdungsbürste / ohne Heizung / ohne Fliehkraftschalter
Sine or Absolute encoder without earthing brush / without heating / without speed switch
Codeur sinus ou absolu sans balai de mise à la terre / sans chauffage / sans accélérer interrupteur

Typ(en) / Type(s) / Type(s)

Baumer-Hübner Benennung	SEW-Benennung
OG73S	ES7S, XS7S
OG83S	EG7S, XG7S
AMG73S	AS7W, AS7Y
AMG83S	AG7W, AG7Y

Richtlinie(n)
Directive(s)
Directive(s)
2014/30/EU; 2014/34/EU; 2011/65/EU; 2006/42/EG

Norm(en)
Standard(s)
Standard(s)
EN 61000-6-2:2005, EN 61000-6-3:2007/A1:2011
EN 60079-0:2012 + A11:2013; EN 60079-15:2010; EN 60079-31:2014; EN 50581:2012

Norme(s)
Norme(s)
EN 61326-3-1:2008, EN 62061:2005 Cor.:2010 + A1:2013 + A2:2015;
EN 61800-3:2004 + A1:2012; EN 61800-5-2:2007; EN ISO 13849-1:2015

Ort und Datum
Place and date
Lieu et date
Berlin, 02.03.2017

Unterschrift/Name/Funktion
Signature/name/function
Signature/nom/fonction
Daniel Kleiner
Head of R&D Motion Control, Baumer Group

Baumer_SEW_SIL_Sinus_Absolutgeber_DE-EN-FR_CoC_81202511.docm/kwe

1/1

Baumer Hübner GmbH P.O. Box 126943 · D-10609 Berlin · Max-Dohrn-Str. 2+4 · D-10589 Berlin
Phone +49 (0)30 69003-0 · Fax +49 (0)30 69003-104 · info@baumerhuebner.com · www.baumer.com
Sitz der Gesellschaft / Registered Office: Berlin, Germany · Geschäftsführer / Managing Director: Dr. Oliver Vietze, Dr. Johann Pohany
Handelsregister / Commercial Registry: AG Charlottenburg HRB 96409 · USt-Id-Nr. / VAT-No.: DE136569055

23480866/EN – 05/2017

Index

Icons

(Dis)assembly work	26, 35
/TF	24

B

Brake	
Braking torque graduations	17
Maintenance intervals	34
Motor/brake assignment.....	16
Brake diagnostics	14
Brake maintenance	38
Brake rectifier combinations	54
Brake replacement	41
DR..160 – 225, DRN132M – 225	44
DR..71 – 80, DRN80	42
DR..90 – 132, DRN90 – 132S	43
Braking torques	52

D

Diagnostic unit /DUE	45
----------------------------	----

E

EI7C FS encoder connection	22
EI7C FS visual feedback	23

F

Functional safety	26, 35
(Dis)assembly work	26, 35
Sealing	26, 35

I

Inspecting the brakemotor	
DR..71 – 225, DRN80 – 225	39
Inspection and maintenance work.....	37
Inspection intervals.....	34

M

Maintenance intervals	34
-----------------------------	----

Mechanical installation

Manual brake release /HR.....	21
Motor maintenance, preliminary work	38
Motor/brake assignment.....	16

P

Perform concentricity test.....	32
Perform wobble measurement	32
Personnel, qualified	26

R

Removing/installing the encoder	27, 28, 30
EG7., AG7.....	30
ES7., AS7.....	28
Removing/installing, encoder	27
Replacing the brake	35

S

Safety notes	
Preliminary information.....	6
Service	26, 35

T

Technical data	
AS7W / AG7W.....	50
AS7Y / AG7Y.....	50
Braking torque graduations	17
Braking work until maintenance, working air gap for BE..(FS) brake	52
EI7C FS.....	51
Encoder	49
ES7S / EG7S.....	49
Temperature sensor /TF.....	24

W

Wear	34
Working air gap	52

10 Glossary

B_{10D}

Number of cycles until 10% of the components endanger through failure (for pneumatic and electromechanical components)

Cat.

Category

CCF

Common cause failure

DC

Diagnostic coverage

DC_{avg}

Average diagnostic coverage

FS

Functional safety

MTTFd

Mean time to dangerous failure

PFH_d

Mean probability of a dangerous failure per hour

PL

Performance level

PLr

Required Performance Level

SAR

Safe Acceleration Range safety function

SBA

Safe Brake Actuation safety function

SBC

Safe Brake Control safety function

SBH

Safe Brake Hold safety function

SBS

Safe brake system

SDI

Safe Direction safety function

SIL

Safety integrity level

SISTEMA

Software of the Institute for Occupational Safety and Health of the German Social Accident Insurance (IFA) for determining the performance level.

SLI

Safely Limited Increment safety function

SLS

Safely Limited Speed safety function

SS1

Safe Stop 1 safety function

SSM

Safe Speed Monitor safety function

STO

Safe Torque Off safety function

T_{10d}

Mean time until 10% of the parts have failed dangerously

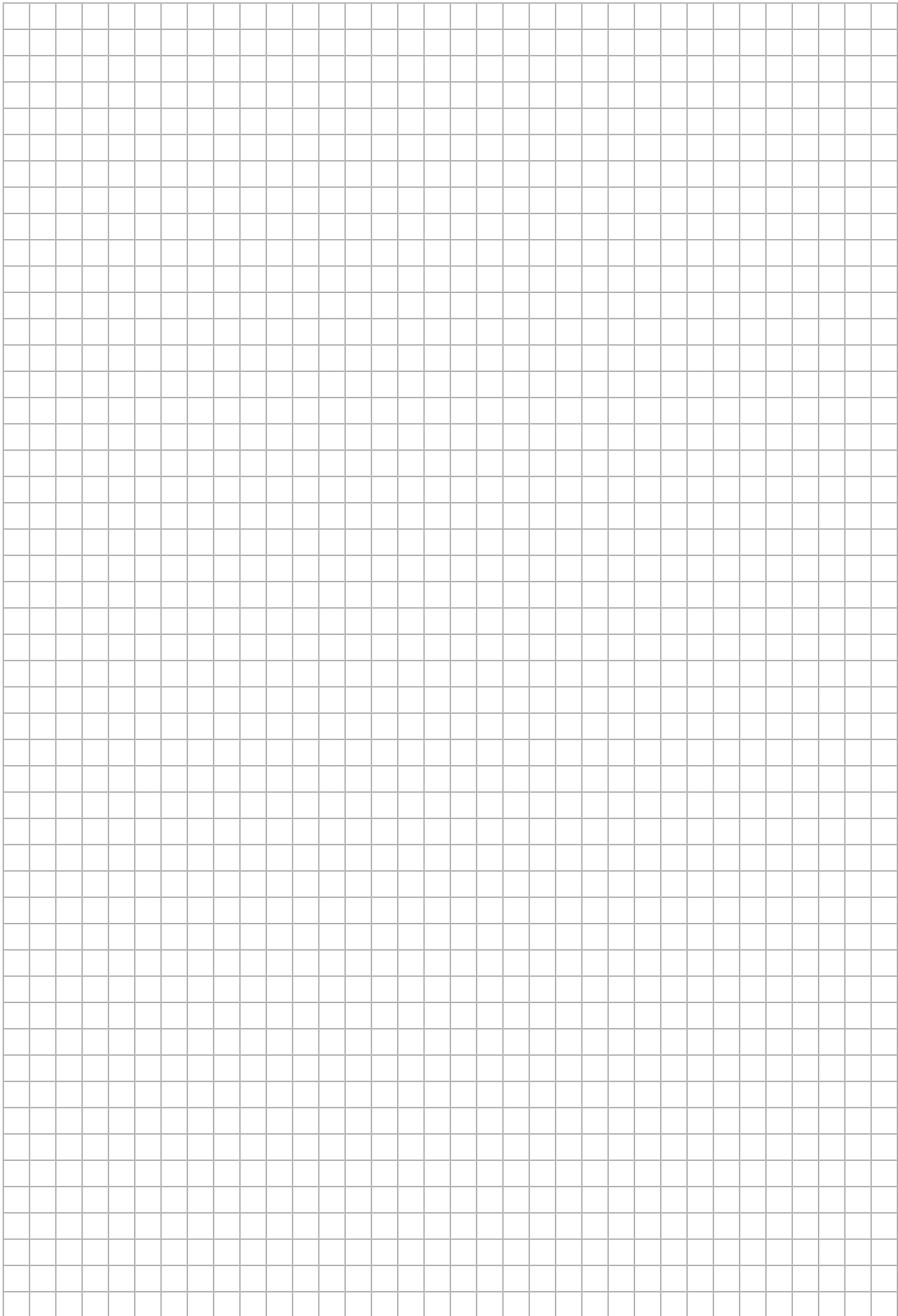

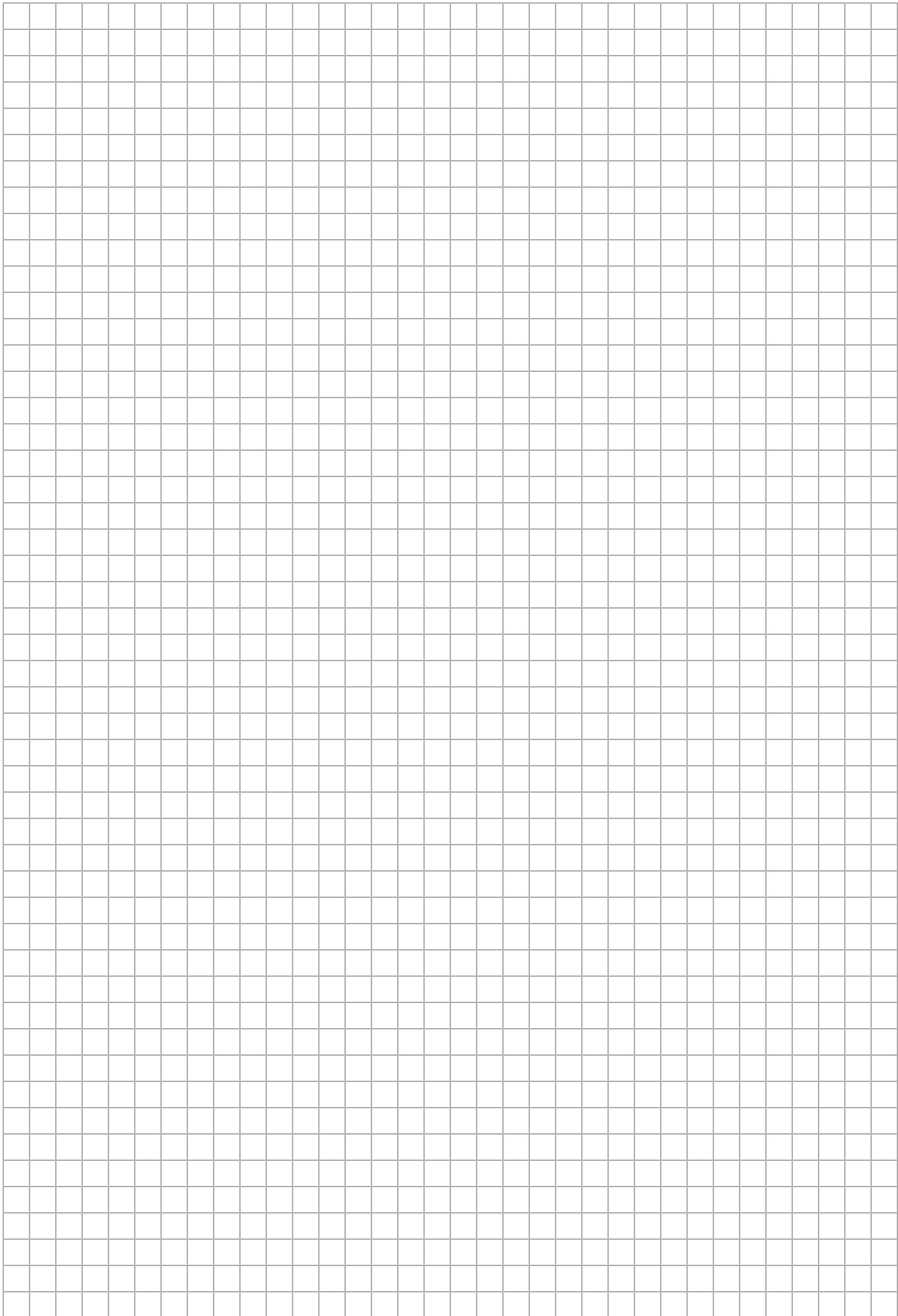

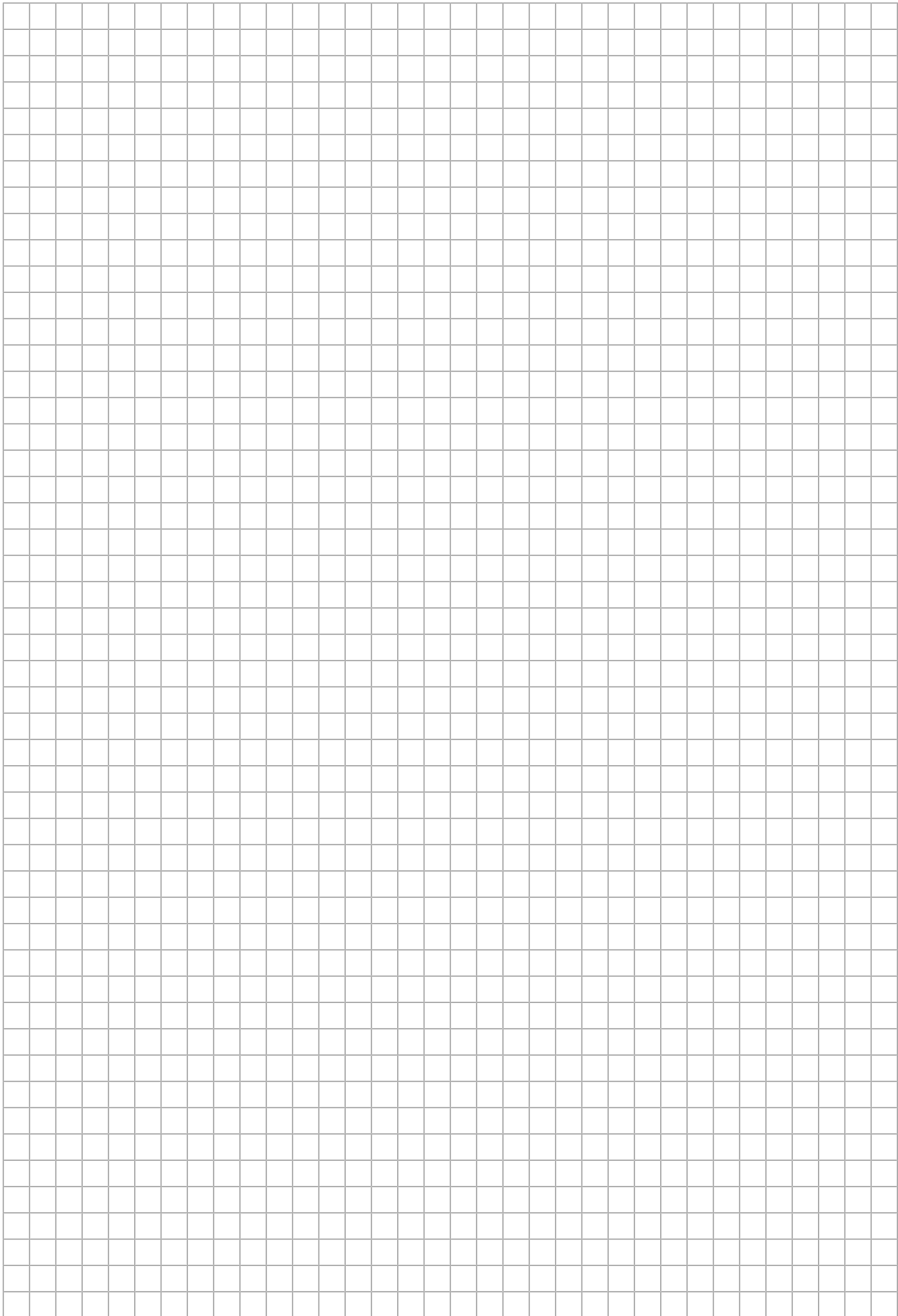

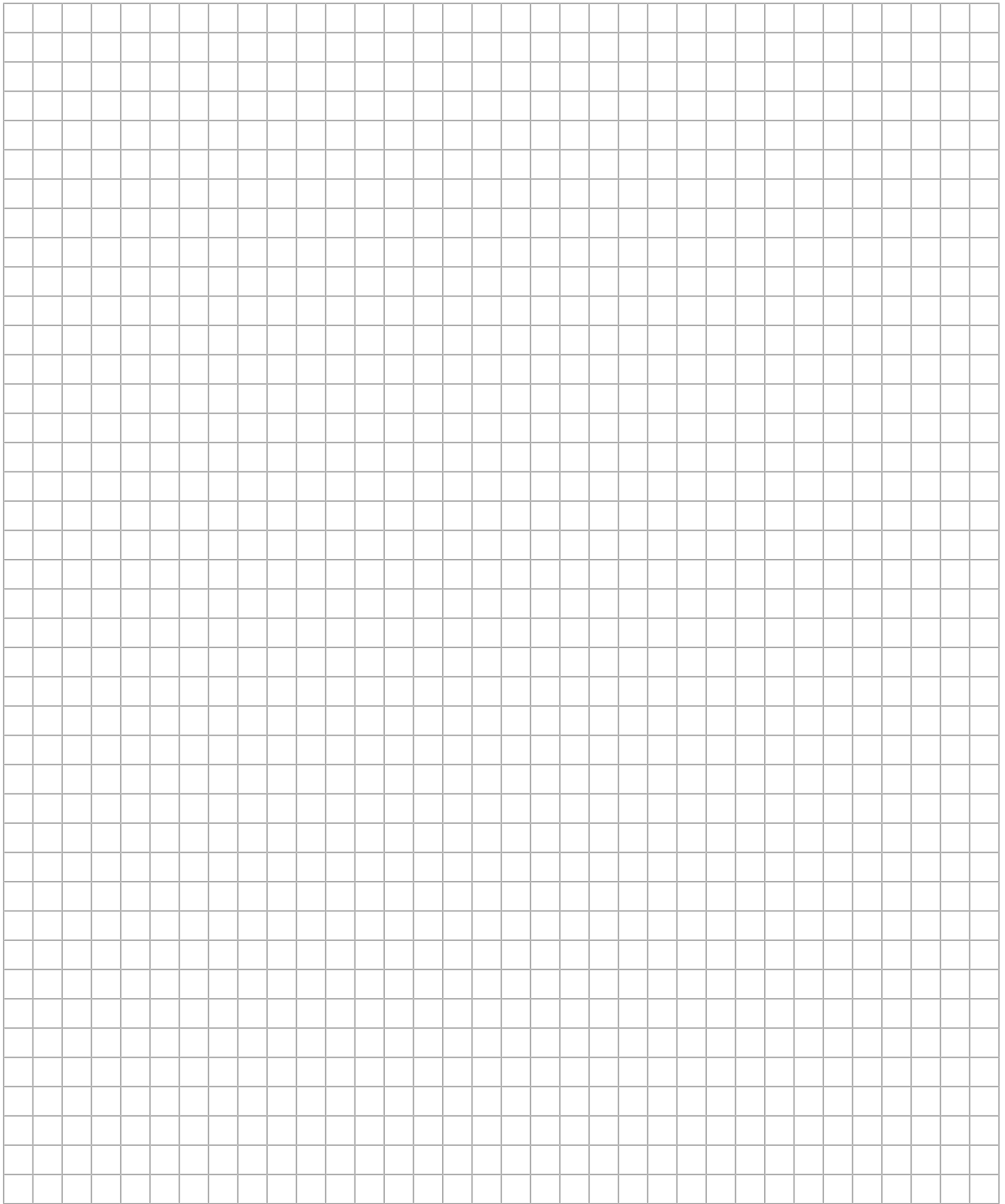

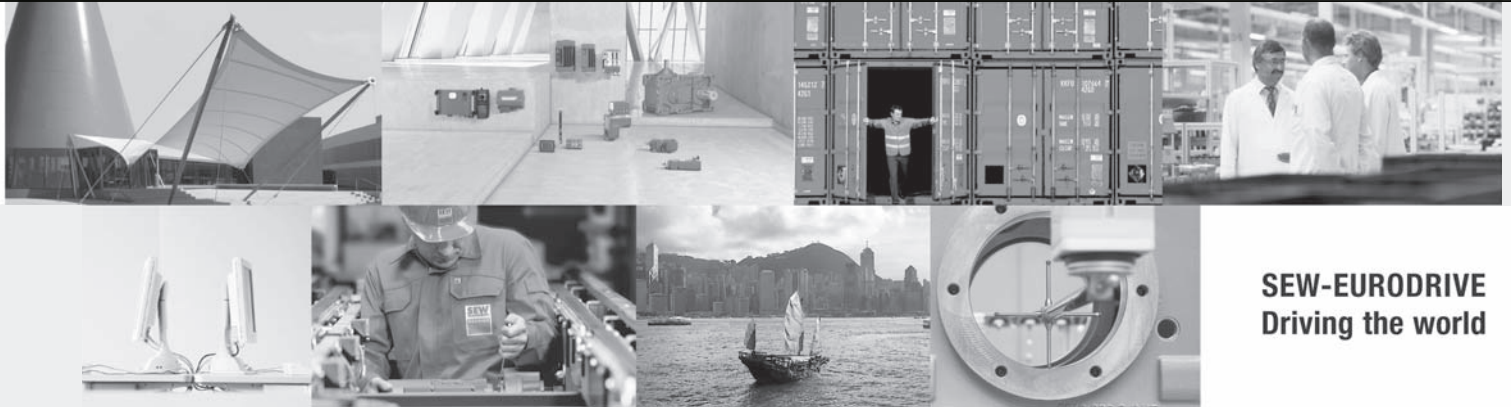

SEW-EURODRIVE
Driving the world

SEW
EURODRIVE

SEW-EURODRIVE GmbH & Co KG
Ernst-Blickle-Str. 42
76646 BRUCHSAL
GERMANY
Tel. +49 7251 75-0
Fax +49 7251 75-1970
sew@sew-eurodrive.com
→ www.sew-eurodrive.com