

HONDA

ENGINES

OWNER'S MANUAL

GXV140

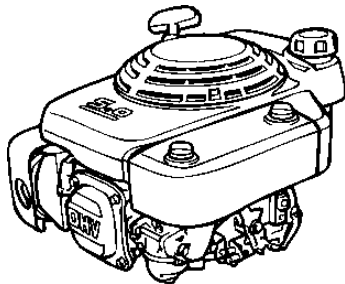

⚠ WARNING: ⚠

The engine exhaust from this product contains chemicals known to the State of California to cause cancer, birth defects or other reproductive harm.

31ZG9642
00X31-ZG9-6420



POM51345D
IPC 20,000.2003.05
PRINTED IN U.S.A.

CONTENTS

INTRODUCTION	1	HELPFUL TIPS & SUGGESTIONS	7
SAFETY MESSAGES	1	Storing Your Engine	7
Damage Prevention Messages	1	Adding A Gasoline Stabilizer to Extend Fuel Storage Life	7
Safety Information	1	Draining the Fuel Tank and Carburetor	8
COMPONENT & CONTROL LOCATION	2	Transporting	8
THROTTLE CABLE CONNECTION	2	TAKING CARE OF UNEXPECTED PROBLEMS	8
BEFORE OPERATION CHECKS	2	TECHNICAL & CONSUMER INFORMATION	9
Is Your Engine Ready to Go	2	TECHNICAL INFORMATION	9
OPERATION	2	Serial Number Location	9
Safe Operating Precautions	2	High Altitude Operation	9
Starting the Engine	3	Oxygenated Fuels	9
Setting Engine Speed	3	Emission Control System Information	10
Stopping the Engine	3	Air Index	10
SERVICING YOUR ENGINE	4	Specifications	10
The Importance of Maintenance	4	CONSUMER INFORMATION	10
Maintenance Safety	4	Honda Publications	10
Safety Precautions	4	Distributor's Limited Warranty	11
Maintenance Schedule	4	Emission Control System Warranty	11
Refueling	4	Distributor/Dealer Locator Information	12
Fuel Recommendations	4	Warranty Service Information	12
Engine Oil	5		
Air Cleaner	5		
Spark Plug	6		
Idle Speed Adjustment	6		
Spark Arrester	7		

INTRODUCTION

Thank you for purchasing a Honda engine. We want to help you to get the best results from your new engine and to operate it safely. This manual contains information on how to do that; please read it carefully before operating the engine. If a problem should arise, or if you have any questions about your engine, consult an authorized Honda servicing dealer.

All information in this publication is based on the latest product information available at the time of printing. American Honda Motor Co., Inc. reserves the right to make changes at any time without notice and without incurring any obligation. No part of this publication may be reproduced without written permission.

This manual should be considered a permanent part of the engine and should remain with the engine if resold.

Review the instructions provided with the equipment powered by this engine for any additional information regarding engine startup, shutdown, operation, adjustments or any special maintenance instructions.

SAFETY MESSAGES

Your safety and the safety of others is very important. We have provided important safety messages in this manual and on the engine. Please read these messages carefully.

A safety message alerts you to potential hazards that could hurt you or others. Each safety message is preceded by a safety alert symbol ⚠ and one of three words, DANGER, WARNING, or CAUTION.

These signal words mean:

- ⚠ DANGER** You WILL be KILLED or SERIOUSLY HURT if you don't follow instructions.
- ⚠ WARNING** You CAN be KILLED or SERIOUSLY HURT if you don't follow instructions.
- ⚠ CAUTION** You CAN be HURT if you don't follow instructions.

Each message tells you what the hazard is, what can happen, and what you can do to avoid or reduce injury.

DAMAGE PREVENTION MESSAGES

You will also see other important messages that are preceded by the word NOTICE.

This word means:

- NOTICE** Your engine or other property can be damaged if you don't follow instructions.

The purpose of these messages is to help prevent damage to your engine, other property, or the environment.

SAFETY INFORMATION

- Understand the operation of all controls and learn how to stop the engine quickly in case of emergency. Make sure the operator receives adequate instruction before operating the equipment.
- Your engine's exhaust contains poisonous carbon monoxide. Do not run the engine without adequate ventilation, and never run the engine indoors.
- The engine and exhaust become very hot during operation. Keep the engine at least 3 feet (1 meter) away from buildings and other equipment during operation. Keep flammable materials away, and do not place anything on the engine while it is running.

COMPONENT & CONTROL LOCATION

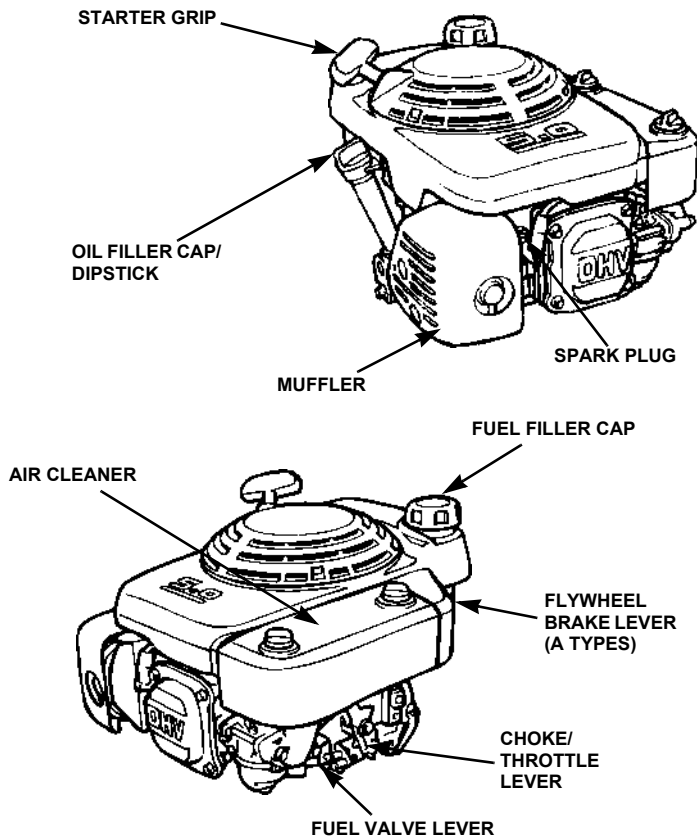

THROTTLE CABLE CONNECTION

The throttle lever is provided with holes for attaching the throttle cable.

1. Remove the screw and the cable holder.
2. Hook the solid wire cable end into the throttle lever as shown.
3. Move the throttle cable control into the fast (or high) throttle position.
4. Move the throttle lever by pulling the throttle cable until the throttle lever just contacts the choke lever. Install the cable holder securing the throttle cable and tighten it securely.

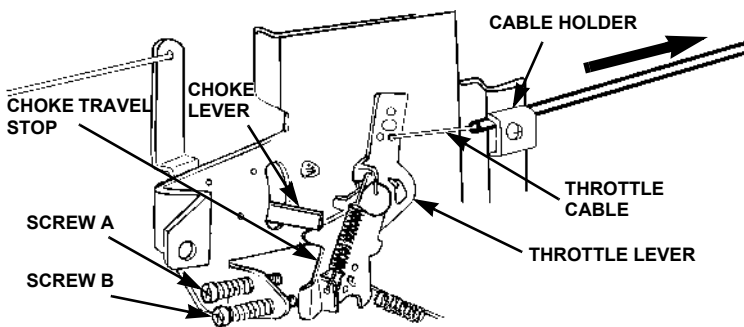

5. Move the throttle control to the choke position and verify that the engine choke rod moves the carburetor choke arm fully closed. If necessary, adjust screw B so it just contacts the choke travel stop.
6. Start the engine and move the throttle lever to the fast (or high) position. Using a tachometer, check the engine speed. Turn screw A to obtain the top no load engine speed specified by the equipment manufacturer.
7. N types: Move the throttle cable control lever to the stop position and confirm that the engine shuts off.

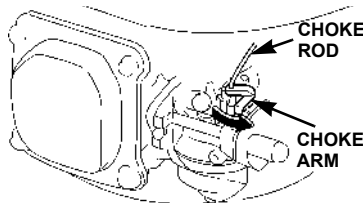

BEFORE OPERATION CHECKS

IS YOUR ENGINE READY TO GO?

For your safety, and to maximize the service life of your equipment, it is very important to take a few moments before you operate the engine to check its condition. Be sure to take care of any problem you find, or have your servicing dealer correct it, before you operate the engine.

⚠ WARNING

Improperly maintaining this engine, or failure to correct a problem before operation, can cause a malfunction in which you can be seriously hurt or killed.

Always perform a preoperation inspection before each operation, and correct any problem.

Before beginning your preoperation checks, be sure the engine is level and the flywheel brake lever (A type engines) or the throttle lever (N type non-flywheel brake engines) is in the STOP position.

Always check the following items before you start the engine:

1. Fuel level (see page 5).
2. Oil level (see page 5).
3. Air cleaner (see page 5).
4. General inspection: Check for fluid leaks and loose or damaged parts.
5. Check the equipment powered by this engine.

Review the instructions provided with the equipment powered by this engine for any precautions and procedures that should be followed before engine startup.

OPERATION

SAFE OPERATING PRECAUTIONS

Before operating the engine for the first time, please review the *SAFETY INFORMATION* section on page 1 and the *BEFORE OPERATION CHECKS* above.

⚠ WARNING

Carbon monoxide gas is toxic. Breathing it can cause unconsciousness and even kill you.

Avoid any areas or actions that expose you to carbon monoxide.

Review the instructions provided with the equipment powered by this engine for any safety precautions that should be observed with engine startup, shutdown, or operation.

STARTING THE ENGINE

1. Turn the fuel valve to the ON position.

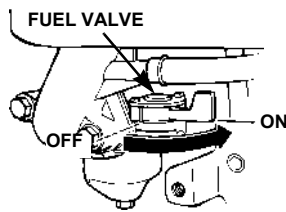

2. FOR STARTING A COLD ENGINE: Move the throttle control to the choke position.

3. FOR RESTARTING A WARM ENGINE: Do not use the choke when the engine is warm.

Move the throttle control slightly past the idle position.

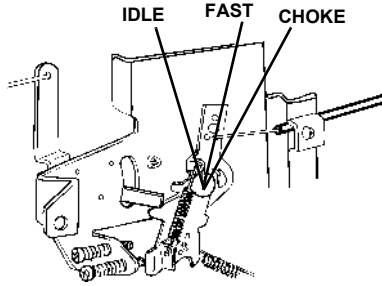

4. FLYWHEEL BRAKE MODELS (A TYPES): Move the flywheel brake lever (located on equipment) to release the flywheel brake.

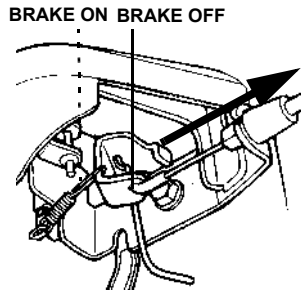

5. Pull the starter grip lightly until resistance is felt, then pull briskly.

NOTICE

Do not allow the starter grip to snap back against the engine. Return it gently to prevent damage to the starter.

6. If the choke was used to start the engine, move the throttle to the fast (or high) position as soon as the engine warms up enough to run smoothly without use of the choke.

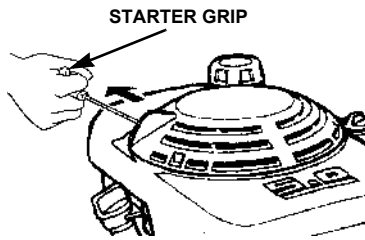

7. FLYWHEEL BRAKE MODELS (A types): Continue to hold the flywheel brake lever (located on equipment). The engine will stop if you release the flywheel brake lever.

SETTING ENGINE SPEED

Position the throttle control for the desired engine speed. For best engine performance, it is recommended the engine be operated with the throttle in the FAST (or high) position.

STOPPING THE ENGINE

1. Move the throttle control to the slow position.
2. Move the throttle control to the stop position.

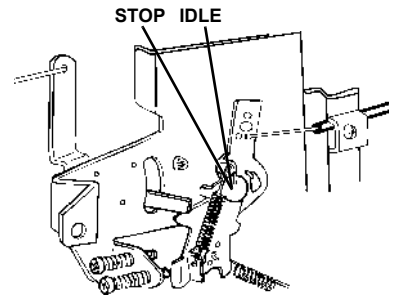

3. FLYWHEEL BRAKE MODELS (A types): Release the flywheel brake lever (located on equipment) to stop the engine.

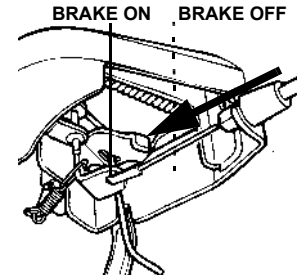

4. Turn the fuel valve to the OFF position if you do not intend to restart the engine soon.

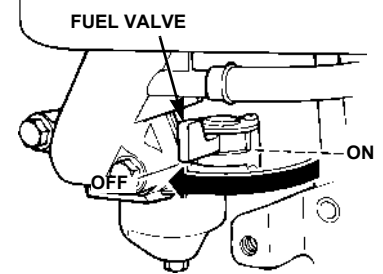

SERVICING YOUR ENGINE

THE IMPORTANCE OF MAINTENANCE

Good maintenance is essential for safe, economical and trouble-free operation. It will also help reduce pollution.

WARNING

Improper maintenance, or failure to correct a problem before operation, can cause a malfunction in which you can be seriously hurt or killed.

Always follow the inspection and maintenance recommendations and schedules in this owner's manual.

To help you properly care for your engine, the following pages include a maintenance schedule, routine inspection procedures, and simple maintenance procedures using basic hand tools. Other service tasks that are more difficult, or require special tools, are best handled by professionals and are normally performed by a Honda technician or other qualified mechanic.

The maintenance schedule applies to normal operating conditions. If you operate your engine under severe conditions, such as sustained high-load or high-temperature operation, or use in unusually wet or dusty conditions, consult your servicing dealer for recommendations applicable to your individual needs and use.

Maintenance, replacement, or repair of the emission control devices and systems may be performed by any engine repair establishment or individual, using parts that are "certified" to EPA standards.

MAINTENANCE SAFETY

Some of the most important safety precautions follow. However, we cannot warn you of every conceivable hazard that can arise in performing maintenance. Only you can decide whether or not you should perform a given task.

WARNING

Failure to properly follow maintenance instructions and precautions can cause you to be seriously hurt or killed.

Always follow the procedures and precautions in this owner's manual.

SAFETY PRECAUTIONS

- Make sure the engine is off before you begin any maintenance or repairs. This will eliminate several potential hazards:
 - **Carbon monoxide poisoning from engine exhaust.**
Be sure there is adequate ventilation whenever you operate the engine.
 - **Burns from hot parts.**
Let the engine and exhaust system cool before touching.
 - **Injury from moving parts.**
Do not run the engine unless instructed to do so.
- Read the instructions before you begin, and make sure you have the tools and skills required.
- To reduce the possibility of fire or explosion, be careful when working around gasoline. Use only a nonflammable solvent, not gasoline, to clean parts. Keep cigarettes, sparks and flames away from all fuel related parts.

Remember that an authorized Honda servicing dealer knows your engine best and is fully equipped to maintain and repair it. To ensure the best quality and reliability, use only new genuine Honda parts or their equivalents for repair and replacement.

MAINTENANCE SCHEDULE

REGULAR SERVICE PERIOD (4)		Before Each Use	First Month or 5 Hrs	Every 3 Months or 25 Hrs	Every 6 Months or 50 Hrs	Every Year or 100 Hrs	Every Two Years or 250 Hrs	Page
ITEM Perform at every indicated month or operating hour interval, whichever comes first.								
Engine oil	Check	O						5
	Replace		O		O (2)			5
Air cleaner	Check	O						5
	Clean			O (1)				
	Replace						O	
Spark plug	Check-adjust					O		6
	Replace						O	
Flywheel brake pad (A types)	Check				O			6
Spark arrester	Clean					O		7
Idle speed	Check-adjust					O(3)		6
Fuel tank and filter	Clean					O(3)		Shop manual
Fuel tube	Check	Every 2 years (Replace if necessary) (3)						Shop manual
Valve clearance	Check-adjust					O(3)		Shop manual
Combustion chamber	Clean	After every 300 hours (3)						—

- (1) Service more frequently when used in dusty areas.
- (2) Change engine oil every 25 hours when used under heavy load or in high ambient temperatures.
- (3) These items should be serviced by an authorized Honda servicing dealer, unless you have the proper tools and are mechanically proficient. Refer to the Honda shop manual for service procedures.
- (4) For commercial use, log hours of operation to determine proper maintenance intervals.

REFUELING

Use unleaded gasoline with a pump octane rating of 86 or higher. This engine is certified to operate on unleaded gasoline. Unleaded gasoline produces fewer engine and spark plug deposits and extends exhaust system life.

WARNING

Gasoline is highly flammable and explosive, and you can be burned or seriously injured when refueling.

- Stop engine and keep heat, sparks, and flame away.
- Refuel only outdoors.
- Wipe up spills immediately.

NOTICE

Fuel can damage paint and some types of plastic. Be careful not to spill fuel when filling your fuel tank. Damage caused by spilled fuel is not covered under the Distributor's Limited Warranty (see page 11).

Never use stale or contaminated gasoline or oil/gasoline mixture. Avoid getting dirt or water in the fuel tank.

Adding Fuel

1. Remove the fuel tank cap.
2. Add fuel to the bottom of the fuel level limit in the neck of the fuel tank. Do not overfill. Wipe up spilled fuel before starting the engine.

Fuel tank capacity:
0.26 US gal (1.1 ℓ)

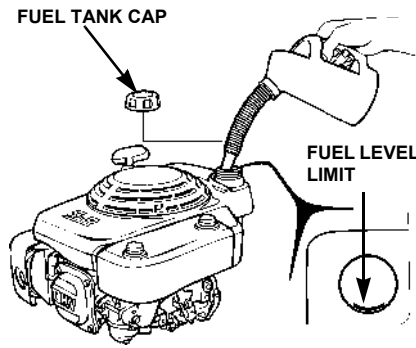

ENGINE OIL

Recommended Oil

Use 4-stroke motor oil that meets or exceeds the requirements for API service classification SH, SJ, or equivalent. Always check the API service label on the oil container to be sure it includes the letters SH, SJ, or equivalent.

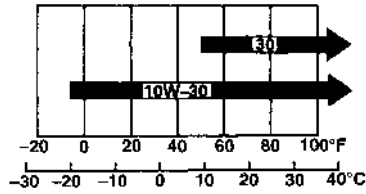

SAE 10W-30 is recommended for general use. Other viscosities shown in the chart may be used when the average temperature in your area is within the indicated range.

Oil Level Check

1. Check the oil with the engine stopped and level.
2. Remove the oil filler cap/dipstick and wipe it clean.
3. Insert the oil filler cap/dipstick into the oil filler neck as shown, but do not screw it in, then remove it to check the oil level.
4. If the oil level is near or below the lower limit mark on the dipstick, remove the oil filler cap/dipstick, and fill with the recommended oil to the upper limit mark (bottom edge of the oil fill hole). Do not overfill.
5. Reinstall the oil filler cap/dipstick.

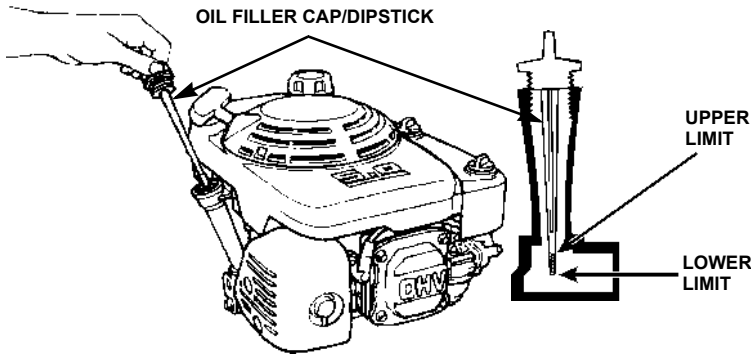

Oil Change

Drain the engine oil when the engine is warm. Warm oil drains quickly and completely.

1. Turn the fuel valve to the OFF position to reduce the possibility of fuel leakage (see page 3).
2. Place a suitable container next to the engine to catch the used oil.
3. Remove the drain bolt and drain the oil into the container by slightly tipping the engine toward the oil filler cap/dipstick.

Please dispose of used motor oil in a manner that is compatible with the environment. We suggest you take used oil in a sealed container to your local recycling center or service station for reclamation. Do not throw it in the trash or pour it on the ground or down a drain.

4. With the engine in a level position, fill to the upper limit mark on the dipstick with the recommended oil (see below).

Engine Oil Capacity:
0.63 US qt (0.60 ℓ)

NOTICE

Running the engine with a low oil level can cause engine damage.

5. Reinstall the oil filler cap/dipstick securely.

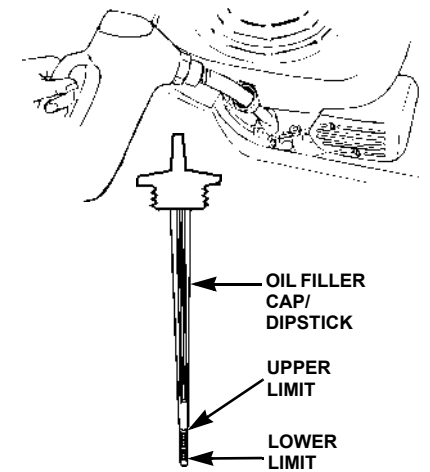
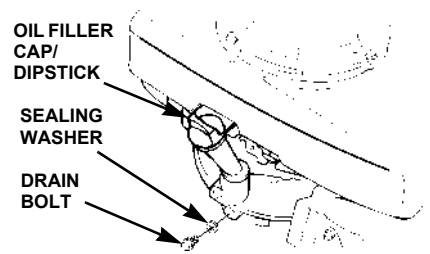

AIR CLEANER

A dirty air cleaner will restrict air flow to the carburetor and cause poor engine performance. Inspect the air cleaner each time the engine is operated. You will need to clean the air cleaner more frequently if you operate the engine in very dusty areas.

NOTICE

Operating the engine without an air cleaner, or with a damaged air cleaner, will allow dirt to enter the engine, causing rapid engine wear. This type of damage is not covered under the Distributor's Limited Warranty (see page 11).

Inspection

1. Remove the two wing bolts, then remove the air cleaner cover. Be careful to prevent dirt and debris from falling into the air cleaner base.
2. Remove the air cleaner from the air cleaner base.
3. Separate the foam element from the paper element.
4. Inspect the air cleaner elements. Replace any damaged elements. Clean or replace dirty elements.

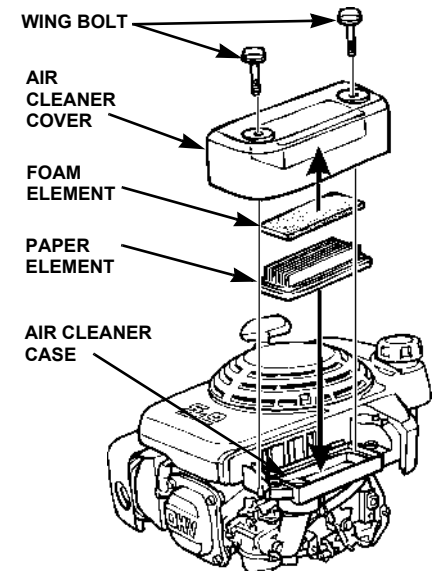

Cleaning

1. Remove the air cleaner cover and foam element, as described in the INSPECTION procedure (see page 5).
2. Remove the paper element from the air cleaner base.
3. Paper element: Tap the element several times on a hard surface to remove excess dirt, or blow compressed air [not exceeding 30 psi (207 kPa)] through the filter from the wire screen side. Never try to brush off dirt; brushing will force dirt into the fibers. Replace the paper element if it is excessively dirty.
4. Foam element: Clean in warm, soapy water or nonflammable solvent, rinse and dry thoroughly. Do not use gasoline as a cleaning solvent, because that would create a risk of fire or explosion. Dip the element in clean engine oil, then squeeze out all excess oil.
5. Excess oil will restrict air flow through the foam element and may transfer to the paper element, soaking and clogging it.
6. Wipe dirt from the air cleaner base and cover using a moist rag. Be careful to prevent dirt from entering the air duct that leads to the carburetor.
7. Reinstall the air cleaner elements, and make sure both elements are properly positioned. Install the air cleaner cover and tighten the two wing bolts securely.

SPARK PLUG

Recommended Spark Plug: BPR5ES (NGK)
W16EPR-U (DENSO)

The recommended spark plug is the correct heat range for normal engine operating temperatures.

NOTICE

Incorrect spark plugs can cause engine damage.

For good performance, the spark plug must be properly gapped and free of deposits.

1. Disconnect the cap from the spark plug, and remove any dirt from the spark plug area.
2. Use the proper size spark plug wrench to remove the spark plug.
3. Inspect the spark plug. Replace it if damaged, badly fouled, if the sealing washer is in poor condition, or if the electrode is worn.
4. Measure the electrode gap with a suitable gauge. The correct gap is 0.028 - 0.031 in (0.70 - 0.80 mm). If adjustment is needed, correct the gap by carefully bending the side electrode.
5. Install the spark plug carefully, by hand, to avoid cross-threading.
6. After the spark plug is seated, tighten with the proper size spark plug wrench to compress the washer.
7. When installing a new spark plug, tighten 1/2 turn after the spark plug seats to compress the washer.
8. When reinstalling the original spark plug, tighten 1/8 - 1/4 turn after the spark plug seats to compress the washer.

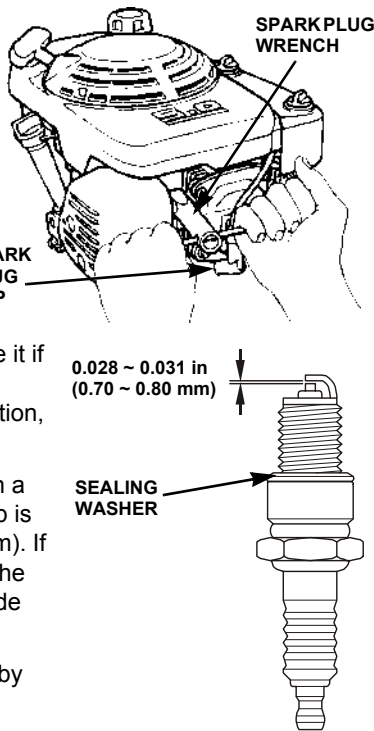

NOTICE

A loose spark plug can become very hot and can damage the engine. Overtightening the spark plug can damage the threads in the cylinder head.

9. Attach the spark plug cap to the spark plug.

IDLE SPEED ADJUSTMENT

1. Start the engine outdoors, and let it warm up to normal operating temperature.
2. Move the throttle control to the slowest position.
3. Using a screwdriver, turn the throttle stop screw to obtain the standard idle speed or the idle speed specified by the equipment manufacturer.

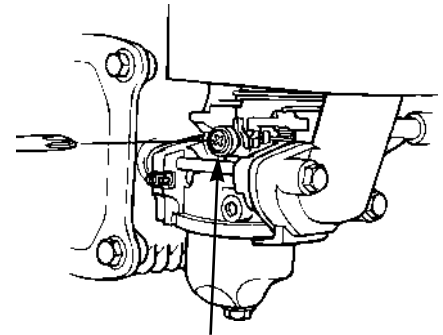

THROTTLE STOP SCREW

Standard Idle Speed:
2,100 ± 150 rpm

FLYWHEEL BRAKE INSPECTION (A types only)

1. Check to see if the inspection screw is contacting the brake bracket.
2. If the inspection screw is contacting the brake bracket, take the engine to an authorized Honda engine servicing dealer for flywheel brake pad inspection.
3. Release the flywheel brake lever (located on equipment), and verify that there is a strong resistance when pulling on the recoil starter. Also verify that the governor arm is moved to the idle (slow) position and there is free play in the cable. The cable should 10 - 15 mm from the centerline as shown when the cable is new.
4. Move the flywheel brake lever to release the flywheel brake, and verify that there is clearance between the governor arm and the throttle return rod when the throttle is in the fast (or high) position.

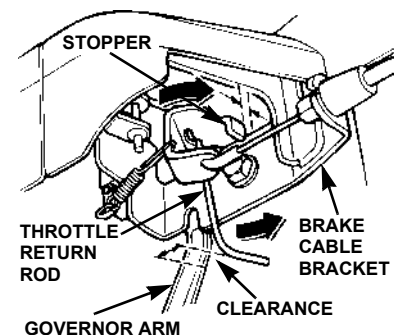
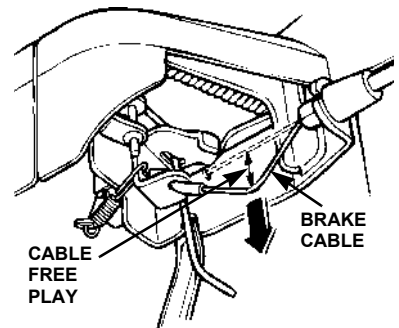
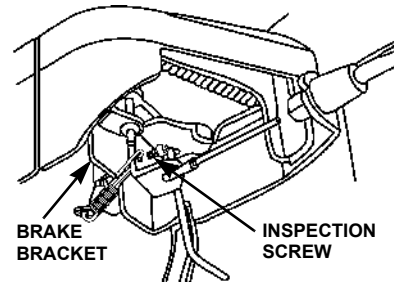

Also verify that there is at least 2 mm clearance between the stopper and the brake cable bracket.

SPARK ARRESTER (optional equipment)

In some areas, it is illegal to operate an engine without a USDA (United States Department of Agriculture)-qualified spark arrester. Check local laws and regulations. A USDA-qualified spark arrester is available from an authorized Honda servicing dealer.

The spark arrester must be serviced every 100 hours to keep it functioning as designed.

If the engine has been running, the muffler will be hot. Allow it to cool before servicing the spark arrester.

Spark Arrester Removal

1. Remove the two nuts from the muffler shield, using a 10 mm wrench.
2. Remove the muffler heat shield, identification plate and muffler.
3. Remove the spark arrester from the muffler.

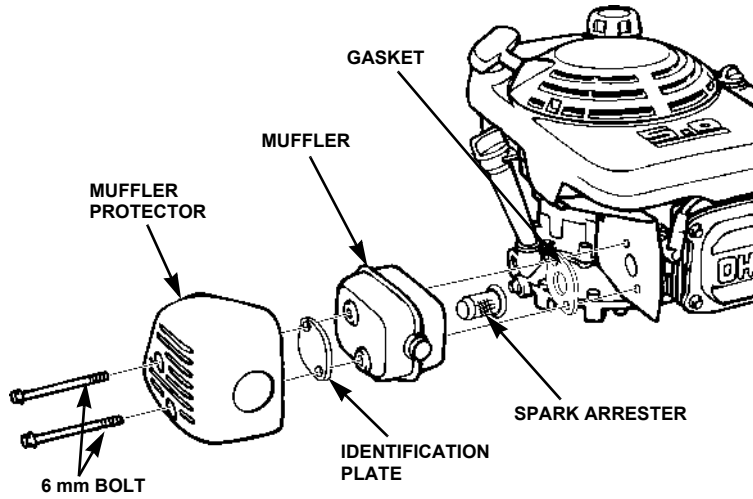

Spark Arrester Cleaning & Inspection

1. Use a brush to remove carbon deposits from the spark arrester screen. Be careful not to damage the screen. Replace the spark arrester if it has breaks or holes.
2. Install the spark arrester in the reverse order of removal.

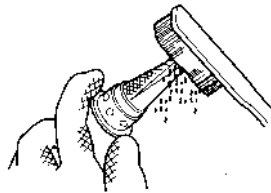

HELPFUL TIPS & SUGGESTIONS

STORING YOUR ENGINE

Storage Preparation

Proper storage preparation is essential for keeping your engine troublefree and looking good. The following steps will help to keep rust and corrosion from impairing your engine's function and appearance, and will make the engine easier to start when you use it again.

Cleaning

If the engine has been running, allow it to cool for at least half an hour before cleaning. Clean all exterior surfaces, touch up any damaged paint, and coat other areas that may rust with a light film of oil.

NOTICE

Using a garden hose or pressure washing equipment can force water into the air cleaner or muffler opening. Water in the air cleaner will soak the air filter, and water that passes through the air filter or muffler can enter the cylinder, causing damage.

Fuel

Gasoline will oxidize and deteriorate in storage. Deteriorated gasoline will cause hard starting, and it leaves gum deposits that clog the fuel system. If the gasoline in your engine deteriorates during storage, you may need to have the carburetor, and other fuel system components, serviced or replaced.

The length of time that gasoline can be left in your fuel tank and carburetor without causing functional problems will vary with such factors as gasoline blend, your storage temperatures, and whether the fuel tank is partially or completely filled. The air in a partially filled fuel tank promotes fuel deterioration. Very warm storage temperatures accelerate fuel deterioration. Fuel problems may occur within a few months, or even less if the gasoline was not fresh when you filled the fuel tank.

Fuel system damage or engine performance problems resulting from neglected storage preparation are not covered under *the Distributor's Limited Warranty* (see page 11).

You can extend fuel storage life by adding a gasoline stabilizer that is formulated for that purpose, or you can avoid fuel deterioration problems by draining the fuel tank and carburetor.

ADDING A GASOLINE STABILIZER TO EXTEND FUEL STORAGE LIFE

When adding a gasoline stabilizer, fill the fuel tank with fresh gasoline. If only partially filled, air in the tank will promote fuel deterioration during storage. If you keep a container of gasoline for refueling, be sure that it contains only fresh gasoline.

1. Add gasoline stabilizer following the manufacturer's instructions.
2. After adding a gasoline stabilizer, run the engine outdoors for 10 minutes to be sure that treated gasoline has replaced the untreated gasoline in the carburetor.
3. Stop the engine, and turn the fuel valve to the OFF position (see page 3).

DRAINING THE FUEL TANK AND CARBURETOR

WARNING

Gasoline is highly flammable and explosive, and you can be burned or seriously injured when handling fuel.

- Stop engine and keep heat, sparks, and flame away.
- Refuel only outdoors.
- Wipe up spills immediately.

1. Place an approved gasoline container below the carburetor, and use a funnel to avoid spilling fuel.
2. Remove the drain bolt, then move the fuel valve lever to the ON position (see page 3).
3. After all the fuel has drained into the container, reinstall the drain bolt and washer. Tighten the drain bolt securely.

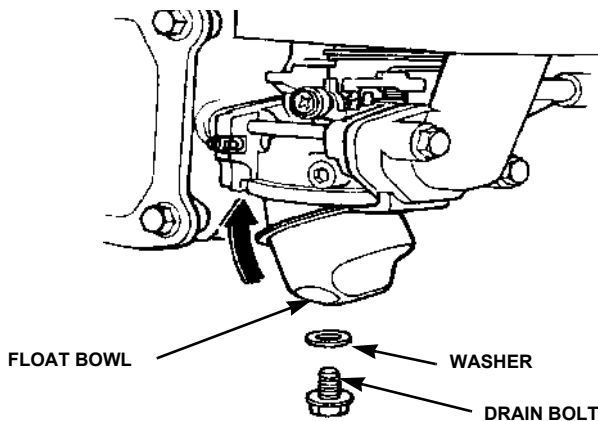

Engine Oil

1. Change the engine oil (see page 5).
2. Remove the spark plug (see page 6).
3. Pour a tablespoon (5 - 10 cc) of clean engine oil into the cylinder.
4. Pull the recoil starter several times to distribute the oil.
5. Reinstall the spark plug.

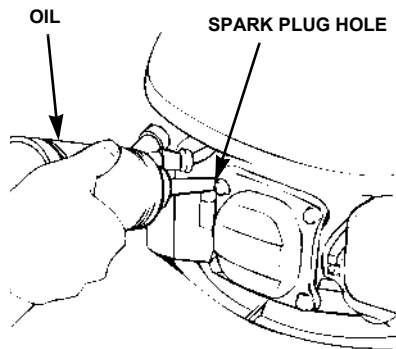

Storage Precautions

If your engine will be stored with gasoline in the fuel tank and carburetor, it is important to reduce the hazard of gasoline vapor ignition. Select a well-ventilated storage area away from any appliance that operates with a flame, such as a furnace, water heater, or clothes dryer. Also avoid any area with a spark-producing electric motor, or where power tools are operated.

If possible, avoid storage areas with high humidity, because that promotes rust and corrosion.

If there is gasoline in the fuel tank, leave the fuel valve in the OFF position (see page 3).

Keep the engine level in storage. Tilting can cause fuel or oil leakage.

With the engine and exhaust system cool, cover the engine to keep out dust. A hot engine and exhaust system can ignite or melt some materials. Do not use sheet plastic as a dust cover. A nonporous cover will trap moisture around the engine, promoting rust and corrosion.

Removal From Storage

Check your engine as described in the *BEFORE OPERATION CHECKS* section of this manual (see page 2).

If the fuel was drained during storage preparation, fill the tank with fresh gasoline. If you keep a container of gasoline for refueling, be sure it contains only fresh gasoline. Gasoline oxidizes and deteriorates over time, causing hard starting.

If the cylinder was coated with oil during storage preparation, the engine will smoke briefly at startup. This is normal.

TRANSPORTING

Keep the engine level when transporting to reduce the possibility of fuel leakage. Turn the fuel valve to the OFF position (see page 3).

TAKING CARE OF UNEXPECTED PROBLEMS

ENGINE WILL NOT START	Possible Cause	Correction
1. Check control positions.	Fuel valve OFF.	Move lever to ON.
	Choke OFF.	Move the choke/throttle lever to CHOKE ON position unless engine is warm.
	Ignition switch OFF.	Move the throttle lever to FAST position. (A types: flywheel brake lever to brake off position.)
2. Check fuel.	Out of fuel.	Refuel.
	Bad fuel; engine stored without treating or draining gasoline, or refueled with bad gasoline.	Drain the fuel tank and carburetor (p. 8). Refuel with fresh gasoline.
3. Remove and inspect spark plug.	Spark plug faulty, fouled, or improperly gapped.	Replace the spark plug (p. 6).
	Spark plug wet with fuel (flooded engine).	Dry and reinstall spark plug. Start engine with choke/throttle lever in FAST position.
4. Take engine to an authorized Honda servicing dealer, or refer to shop manual.	Fuel filter clogged, carburetor malfunction, ignition malfunction, valves stuck, etc.	Replace or repair faulty components as necessary.

ENGINE LACKS POWER	Possible Cause	Correction
1. Check air cleaner	Air cleaner elements clogged.	Clean or replace air cleaner elements (p. 6).
2. Check fuel.	Bad fuel; engine stored without treating or draining gasoline, or refueled with bad gasoline.	Drain the fuel tank and carburetor (p. 8). Refuel with fresh gasoline.
3. Take engine to an authorized Honda servicing dealer, or refer to shop manual.	Fuel filter clogged, carburetor malfunction, ignition malfunction, valves stuck, etc.	Replace or repair faulty components as necessary.

TECHNICAL & CONSUMER INFORMATION

TECHNICAL INFORMATION

Serial Number Location

Record the engine serial number in the space below. You will need this information when ordering parts and when making technical or warranty inquiries.

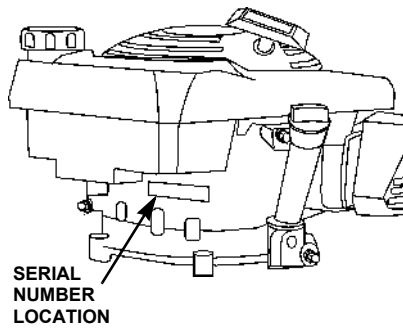

Engine serial number: **GJAB** - _____

Carburetor Modifications for High Altitude Operation

At high altitude, the standard carburetor air-fuel mixture will be too rich. Performance will decrease, and fuel consumption will increase. A very rich mixture will also foul the spark plug and cause hard starting. Operation at an altitude that differs from that at which this engine was certified, for extended periods of time, may increase emissions.

High altitude performance can be improved by specific modifications to the carburetor. If you always operate your engine at altitudes above 5,000 feet (1,500 meters), have authorized Honda servicing dealer perform this carburetor modification. This engine, when operated at high altitude with the carburetor modifications for high altitude use, will meet each emission standard throughout its useful life.

Even with carburetor modification, engine horsepower will decrease about 3.5% for each 1,000 feet (300 meters) increase in altitude. The effect of altitude on horsepower will be greater than this if no carburetor modification is made.

NOTICE

When the carburetor has been modified for high altitude operation, the air-fuel mixture will be too lean for low altitude use. Operation at altitudes below 5,000 feet (1,500 meters) with a modified carburetor may cause the engine to overheat and result in serious engine damage. For use at low altitudes, have an authorized Honda servicing dealer return the carburetor to original factory specifications.

Oxygenated Fuels

Some conventional gasolines are being blended with alcohol or an ether compound. These gasolines are collectively referred to as oxygenated fuels. To meet clean air standards, some areas of the United States and Canada use oxygenated fuels to help reduce emissions.

If you use oxygenated fuel, be sure it is unleaded and meets the minimum octane rating requirements.

Before using an oxygenated fuel, try to confirm the fuel's contents. Some states/provinces require this information to be posted on the pump.

The following are the EPA approved percentages of oxygenates:

- ETHANOL** — (ethyl or grain alcohol) 10% by volume
You may use gasoline containing up to 10% ethanol by volume. Gasoline containing ethanol may be marketed under the name Gasohol.
- MTBE** — (methyl tertiary butyl ether) 15% by volume
You may use gasoline containing up to 15% MTBE by volume.
- METHANOL** — (methyl or wood alcohol) 5% by volume
You may use gasoline containing up to 5% methanol by volume as long as it also contains cosolvents and corrosion inhibitors to protect the fuel system. Gasoline containing more than 5% methanol by volume may cause starting and/or performance problems. It may also damage metal, rubber, and plastic parts of your fuel system.

If you notice any undesirable operating symptoms, try another service station or switch to another brand of gasoline.

Fuel system damage or performance problems resulting from the use of an oxygenated fuel containing more than the percentages of oxygenates mentioned above are not covered under *the Distributor's Limited Warranty* (see page 11).

Emission Control System Information

Source of Emissions

The combustion process produces carbon monoxide, oxides of nitrogen, and hydrocarbons. Control of hydrocarbons and oxides of nitrogen is very important because, under certain conditions, they react to form photochemical smog when subjected to sunlight. Carbon monoxide does not react in the same way, but it is toxic.

Honda utilizes lean carburetor settings and other systems to reduce the emissions of carbon monoxide, oxides of nitrogen, and hydrocarbons.

The U.S. and California Clean Air Acts

EPA and California regulations require all manufacturers to furnish written instructions describing the operation and maintenance of emission control systems.

The following instructions and procedures must be followed in order to keep the emissions from your Honda engine within the emission standards.

Tampering and Altering

Tampering with or altering the emission control system may increase emissions beyond the legal limit. Among those acts that constitute tampering are:

- Removal or alteration of any part of the intake, fuel, or exhaust systems.
- Altering or defeating the governor linkage or speed-adjusting mechanism to cause the engine to operate outside its design parameters.

Problems That May Affect Emissions

If you are aware of any of the following symptoms, have your engine inspected and repaired by your servicing dealer.

- Hard starting or stalling after starting.
- Rough idle.
- Misfiring or backfiring under load.
- Afterburning (backfiring).
- Black exhaust smoke or high fuel consumption.

Replacement Parts

The emission control systems on your Honda engine were designed, built, and certified to conform with EPA and California emission regulations. We recommend the use of genuine Honda parts whenever you have maintenance done. These original-design replacement parts are manufactured to the same standards as the original parts, so you can be confident of their performance. The use of replacement parts that are not of the original design and quality may impair the effectiveness of your emission control system.

A manufacturer of an aftermarket part assumes the responsibility that the part will not adversely affect emission performance. The manufacturer or rebuilder of the part must certify that use of the part will not result in a failure of the engine to comply with emission regulations.

Maintenance

Follow the maintenance schedule on page 4. Remember that this schedule is based on the assumption that your machine will be used for its designed purpose. Sustained high-load or high-temperature operation, or use in unusually wet or dusty conditions, will require more frequent service.

Air Index

An Air Index Information hang tag/label is applied to engines certified to an emission durability time period in accordance with the requirements of the California Air Resources Board.

The bar graph is intended to provide you, our customer, the ability to compare the emissions performance of available engines. The lower the Air Index, the less pollution.

The durability description is intended to provide you with information relating the engine's emission durability period. The descriptive term indicates the useful life period for the engine's emission control system. See your *Emission Control System Warranty* (page 11) for additional information.

Descriptive Term	Applicable to Emissions Durability Period
Moderate	50 hours (0–65 cc) 125 hours (greater than 65 cc)
Intermediate	125 hours (0–65 cc) 250 hours (greater than 65 cc)
Extended	300 hours (0–65 cc) 500 hours (greater than 65 cc)

The Air Index Information hang tag/label must remain on the engine until it is sold. Remove the hang tag before operating the engine.

Specifications

Type	N1	N2	A1	A2
Length x Width x Height in (mm)	15.6 x 13.2 x 13.4 (395 x 335 x 340)	15.6 x 13.2 x 12.8 (395 x 335 x 325)	15.6 x 13.2 x 13.4 (395 x 335 x 340)	15.6 x 13.2 x 12.8 (395 x 335 x 325)
Dry weight lb (kg)	25.6 (11.5)	25.6 (11.5)	25.1 (11.3)	25.1 (11.3)
Engine type	4-stroke, overhead valve, single cylinder			
Displacement [Bore x Stroke]	8.2 cu in (135 cm ³) [2.7 x 1.8 in (68 x 45 mm)]			
Max. output	5.0 bhp at 3,600 rpm			
Max. torque	7.6 ft-lb (1.05 kg/m) at 2,500 rpm			
Fuel consumption	0.514 lb/hph (313 g/kWh)			
Cooling system	Forced air			
Lubrication systems	Forced splash			
Ignition system	CDI			
PTO shaft rotation	Counterclockwise			

Tuneup Specifications

ITEM	SPECIFICATION	MAINTENANCE
Spark plug gap	0.028 – 0.031 in (0.7 – 0.8 mm)	Refer to page 6.
Valve clearance (cold)	IN: 0.15 ± 0.04 mm EX: 0.20 ± 0.04 mm	See your authorized Honda dealer
Other specifications	No other adjustments needed.	

CONSUMER INFORMATION

Honda Publications

These publications will give you additional information for maintaining and repairing your engine. You may order them from an authorized Honda engine servicing dealer.

Shop Manual	This manual covers complete maintenance and overhaul procedures. It is intended to be used by a skilled technician.
Parts Catalog	This manual provides complete, illustrated parts lists.

Distributor's Limited Warranty

PRODUCTS COVERED BY THIS WARRANTY:		LENGTH OF WARRANTY: (FROM DATE OF ORIGINAL PURCHASE)	
PRODUCT	APPLICATIONS	NONCOMMERCIAL/ NONRENTAL	COMMERCIAL /RENTAL
GXV Series Engines	All (1)	24 months	12 months

1. Honda GXV series general purpose engines have a 3 month warranty period when installed on concession type vehicles.

To Qualify for this Warranty:

The Honda general purpose engine must be purchased from a Honda general purpose engine dealer or distributor authorized to sell that product in the United States, Puerto Rico, or the U.S. Virgin Islands. This limited warranty applies to first retail purchaser and each subsequent owner during the applicable warranty time period.

What American Honda Will Repair or Replace Under Warranty:

American Honda will repair or replace, at its option, any part that is proven to be defective in material or workmanship under normal use during the applicable warranty time period. Warranty repairs and replacements will be made without charge for parts or labor. Anything replaced under warranty becomes the property of American Honda Motor Company, Inc. All parts replaced under warranty will be considered as part of the original product and any warranty on those parts will expire coincident with the original product warranty.

To Obtain Warranty Service:

You must take your Honda general purpose engine, or the equipment in which it is installed, together with proof of original retail purchase date, at your expense, to a Honda engine dealer or distributor authorized to sell that product in the United States, Puerto Rico, or the U.S. Virgin Islands, during their normal business hours. Many Honda engine dealers and distributors are listed in the yellow pages of the telephone directory under gasoline engines, lawn & garden equipment & supplies, etc.

If you are unable to obtain warranty service, or are dissatisfied with the warranty service you receive, take the following steps: First, contact the owner of the dealership or distributor involved; normally this should resolve the problem. However, if you should require further assistance, write or call the Power Equipment Customer Relations Department of American Honda Motor Co., Inc. Refer to page 12 for contact information.

Exclusions:

THIS WARRANTY DOES NOT EXTEND TO PARTS AFFECTED OR DAMAGED BY THE PRODUCT IN WHICH THE ENGINE IS INSTALLED, OR BY ACCIDENT AND/OR COLLISION, MISUSE, NEGLIGENCE, PARTS WORN BEYOND SERVICE LIMITS DUE TO NORMAL WEAR/NORMAL SERVICE LIFE, PARTS AFFECTED OR DAMAGED BY THE CONVERSION TO OR USE OF FUEL OTHER THAN THE FUEL(S) WHICH THE ENGINE IS ORIGINALLY MANUFACTURED TO USE, POOR OPERATION RELATED TO FUEL CONTAMINATION OR FUEL QUALITY, PARTS DAMAGED BY FUEL CONTAMINATION, THE INCORPORATION OF, OR USE OF, UNSUITABLE ATTACHMENTS OR PARTS, THE UNAUTHORIZED ALTERATION OF ANY PART OR ANY CAUSES OTHER THAN DEFECTS IN MATERIAL OR WORKMANSHIP OF THE ENGINE. USE OF THE HONDA GENERAL PURPOSE ENGINE FOR RACING OR COMPETITION WILL VOID THIS WARRANTY.

Disclaimer of Consequential Damage and Limitation of Implied Warranties:

AMERICAN HONDA DISCLAIMS ANY RESPONSIBILITY FOR LOSS OF TIME OR USE OF THE ENGINE, OR THE EQUIPMENT IN WHICH THE ENGINE IS INSTALLED, TRANSPORTATION, COMMERCIAL LOSS, OR ANY OTHER INCIDENTAL OR CONSEQUENTIAL DAMAGE. ANY IMPLIED WARRANTIES ARE LIMITED TO THE DURATION OF THIS WRITTEN LIMITED WARRANTY. Some states do not allow limitations on how long an implied warranty lasts and/or do not allow the exclusion or limitation of incidental or consequential damages, so the above exclusions and limitations may not apply to you.

This warranty gives you specific legal rights, and you may also have other rights which vary from state to state.

Emission Control System Warranty

Your new Honda Power Equipment engine complies with both the U.S. EPA and State of California emission regulations. American Honda provides the same emission warranty coverage for engines sold in all 50 states.

Your Warranty Rights And Obligations:

California

The California Air Resources Board and American Honda Motor Co., Inc. are pleased to explain the emission control system warranty on your Honda Power Equipment engine. In California, new utility and lawn and garden equipment engines must be designed, built and equipped to meet the State's stringent anti-smog standards.

Other States

In other areas of the United States your engine must be designed, built, and equipped to meet the U.S. EPA emission standards for spark-ignited engines at or below 19 kilowatts.

All States

American Honda Motor Co., Inc. must warrant the emission control system on your power equipment engine for the period of time listed below provided there has been no abuse, neglect or improper maintenance of your power equipment engine. Where a warrantable condition exists, American Honda Motor Co., Inc. will repair your power equipment engine at no cost to you including diagnosis, parts and labor.

Your emission control system may include such parts as the carburetor or fuel injection system, the ignition system, and catalytic converter. Also included may be hoses, connectors and other emission-related assemblies.

Manufacturer's Warranty Coverage:

The 1995 and later power equipment engines are warranted for two years. If any emission-related part on your engine is defective, the part will be repaired or replaced by American Honda Motor Co., Inc.

Owner's Warranty Responsibility:

As the power equipment engine owner, you are responsible for the performance of the required maintenance listed in your owner's manual. American Honda Motor Co., Inc. recommends that you retain all receipts covering maintenance on your power equipment engine, but American Honda Motor Co., Inc. cannot deny warranty coverage solely for the lack of receipts or for your failure to ensure the performance of all scheduled maintenance.

As the power equipment engine owner, you should however be aware that American Honda Motor Co., Inc. may deny you warranty coverage if your power equipment engine or a part has failed due to abuse, neglect, improper maintenance, or unapproved modifications.

You are responsible for presenting your power equipment engine to a Honda Power Equipment dealer as soon as a problem exists. The warranty repairs should be completed in a reasonable amount of time, not to exceed 30 days.

If you have any questions regarding your warranty rights and responsibilities, you should write or call the Honda Power Equipment Customer Relations Department. Refer to page 12 for contact information.

Warranty Coverage:

Honda power equipment engines manufactured after January 1, 1995 and sold in the State of California, and U.S. EPA certified engines manufactured on or after September 1, 1996 and sold in all of the United States, are covered by this warranty for a period of two years from the date of delivery to the original retail purchaser. This warranty is transferable to each subsequent purchaser for the duration of the warranty period.

Warranty repairs will be made without charge for diagnosis, parts or labor. All defective parts replaced under this warranty become the property of American Honda Motor Co., Inc. A list of warranted parts is on the reverse side of this warranty statement. Normal maintenance items, such as spark plugs and filters, that are on the warranted parts list are warranted up to their required replacement interval only.

American Honda Motor Co., Inc. is also liable for damages to other engine components caused by a failure of any warranted part during the warranty period.

Only Honda approved replacement parts may be used in the performance of any warranty repairs and must be provided without charge to the owner. The use of replacement parts not equivalent to the original parts may impair the effectiveness of your engine emission control system. If such a replacement part is used in the repair or maintenance of your engine, and an authorized Honda dealer determines it is defective or causes a failure of a warranted part, your claim for repair of your engine may be denied. If the part in question is not related to the reason your engine requires repair, your claim will not be denied.

To Obtain Warranty Service:

You must take your Honda Power Equipment engine or the product on which it is installed, along with your warranty registration card or other proof of original purchase date, at your expense, to any Honda Power Equipment dealer who is authorized by American Honda Motor Co., Inc. to sell and service that Honda product during his normal business hours. Claims for repair or adjustment found to be caused solely by defects in material or workmanship will not be denied because the engine was not properly maintained and used.

If you are unable to obtain warranty service, or are dissatisfied with the warranty service you received, contact the owner of the dealership involved. Normally this should resolve your problem. However, if you require further assistance, write or call the Power Equipment Customer Relations Department of American Honda Motor Co., Inc.

Exclusions:

FAILURES OTHER THAN THOSE RESULTING FROM DEFECTS IN MATERIAL OR WORKMANSHIP ARE NOT COVERED BY THIS WARRANTY. THIS WARRANTY DOES NOT EXTEND TO EMISSION CONTROL SYSTEMS OR PARTS WHICH ARE AFFECTED OR DAMAGED BY OWNER ABUSE, NEGLIGENCE, IMPROPER MAINTENANCE, MISUSE, MISFUELING, IMPROPER STORAGE, ACCIDENT AND/OR COLLISION, THE INCORPORATION OF, OR ANY USE OF, ANY ADD-ON OR MODIFIED PARTS, UNSUITABLE ATTACHMENTS, OR THE UNAUTHORIZED ALTERATION OF ANY PART.

THIS WARRANTY DOES NOT COVER REPLACEMENT OF EXPENDABLE MAINTENANCE ITEMS MADE IN CONNECTION WITH REQUIRED MAINTENANCE SERVICES AFTER THE ITEM'S FIRST SCHEDULED REPLACEMENT AS LISTED IN THE MAINTENANCE SECTION OF THE PRODUCT OWNER'S MANUAL, SUCH AS: SPARK PLUGS AND FILTERS.

Disclaimer of Consequential Damage and Limitation of Implied Warranties:

AMERICAN HONDA MOTOR CO., INC. DISCLAIMS ANY RESPONSIBILITY FOR INCIDENTAL OR CONSEQUENTIAL DAMAGES SUCH AS LOSS OF TIME OR THE USE OF THE POWER EQUIPMENT, OR ANY COMMERCIAL LOSS DUE TO THE FAILURE OF THE EQUIPMENT; AND ANY IMPLIED WARRANTIES ARE LIMITED TO THE DURATION OF THIS WRITTEN WARRANTY. THIS WARRANTY IS APPLICABLE ONLY WHERE THE CALIFORNIA OR U.S. EPA EMISSION CONTROL SYSTEM WARRANTY REGULATION IS IN EFFECT.

Emission Control System Warranty Parts:

SYSTEMS COVERED BY THIS WARRANTY:	PARTS DESCRIPTION:
Fuel Metering	Carburetor assembly, Fuel injection pump, Fuel injection nozzle, Fuel regulator
Exhaust	Catalyst
Air Induction	Air filter housing, Air filter element*, Crankcase breather tube
Ignition	Flywheel magneto, Ignition pulse generator, Ignition coil assembly, Ignition control module, Spark plug cap, Spark plug*
Miscellaneous Parts	Tubing, fittings, seals, gaskets, and clamps associated with these listed systems.
* Covered up to the first required replacement only. See the Maintenance Schedule on page 4.	

Distributor/Dealer Locator Information

To find an Authorized Honda Engine Distributor/Dealer anywhere in the United States:

Visit our website: www.honda-engines.com

Warranty Service Information

Servicing dealership personnel are trained professionals. They should be able to answer any question you may have. If you encounter a problem that your dealer does not solve to your satisfaction, please discuss it with the dealership's management. The Service Manager, General Manager, or Owner can help. Almost all problems are solved in this way.

If you are dissatisfied with the decision made by the dealership's management, contact the Honda Regional Engine Distributor for your area. You can find their name, address, and phone number by using the distributor/dealer locator information listed above.

If you are still dissatisfied after speaking with the Regional Engine Distributor, you may contact the Honda Power Equipment Customer Relations Office. You can write to:

American Honda Motor Co., Inc.
Power Equipment Division
Customer Relations Office
4900 Marconi Drive
Alpharetta, Georgia 30005-8847

Or telephone: (770) 497-6400

When you write or call, please give us this information:

- Model and serial number (see page 9)
- Name of dealer who sold the engine to you
- Name, address, and contact person of dealer who services your engine
- Name of Distributor contact person
- Date of purchase
- Your name, address and telephone number
- A detailed description of the problem