

# LG HVAC SOLUTION

## ***MULTI V™ 5***

### INDOOR UNITS

CONTROL SOLUTION

ACCESSORIES



# ENGINEERING CAPABILITY :HVAC TOOL & SUPPORT

From planning to service & maintenance and then to de-construction, an architectural project goes along many stages from the beginning to the end of its lifecycle. Along those stages, various engineering tools are applied to solve the diverse issues happening in each stage, with the most optimal solution possible. Due to the usage of such tools, buildings are effectively designed, built, supervised, and maintained throughout the lifecycle.

Dedicated to provide exceptional HVAC engineering support, LG Electronics Air-Solution Business Unit offers several engineering tools and solutions focused on HVAC, during the overall lifecycle of a building, related to the three categories: I. Draft Energy Estimation, II. Model Selection & Design, and III. Installation Environment Simulation. Among them, the LATS\* Program series has been developed to offer optimised tool for LG HVAC systems, providing our customers a fast, easy, and accurate way in everyday duties of Model-selection, Draft Energy Estimation & Designing, and many more.

## \* LATS : LG Air-conditioner Technical Solution



I

**Energy Estimation**



II

**Model Selection & Design**



III

**Installation Environment Simulation**

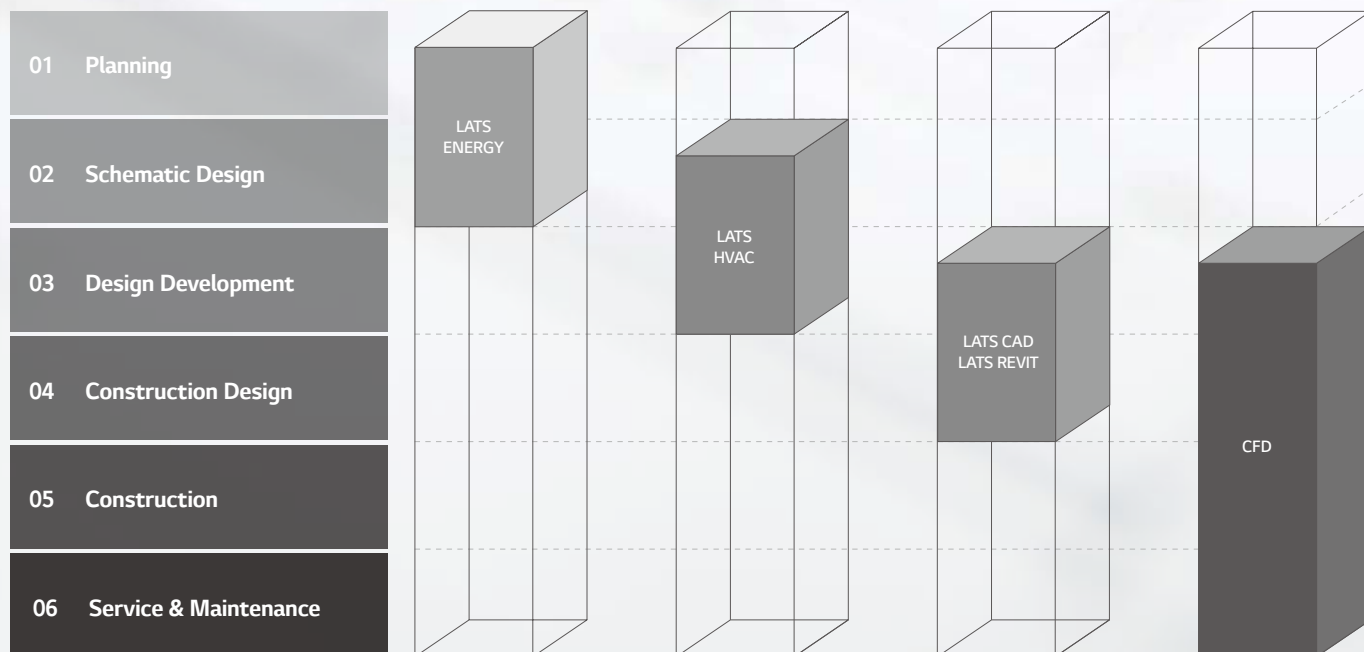

### 01 Draft Energy Estimation

#### LATS Energy

LATS Energy program is a draft energy estimation program, self-developed by LG. This program helps estimate the draft energy usage and analyses the life cycle cost of LG VRF models during the early stage of a project.



### 02 Model Selection

#### LATS HVAC

LATS HVAC is an integrated model selection program of LG HVAC products, enabling an accurate and quick selection on the best model suitable to each sites. In addition to model selection, faster estimation on refrigerant piping diameter and additional refrigerant is possible, along with auto printing of reports.

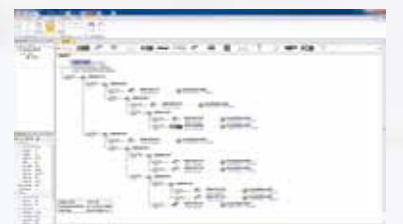

### 03 Design

#### LATS CAD

LATS CAD enables faster and a more accurate design of LG HVAC products. Moreover, it offers not only designing, but also quotation and installation review in order to minimise problems during installation processes.



#### LATS Revit

LATS REVIT is developed to make 3D designing of LG HVAC products easier than the previous program. It enables engineers to check 3D images from designing stage and prevents possible issues of the installation stage.



### 04 Installation Environment Simulation

#### CFD Analysis

CFD Analysis is applied in areas of estimating: indoor airflow and temperature distribution while operating VRF products, outdoor airflow distribution, and noise level. By running a simulation before construction, engineers estimate possible issues and find optimal solutions of malfunction that could occur after construction.

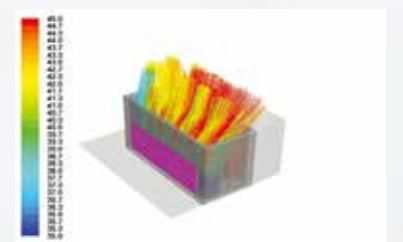



# LG CONTROL SOLUTION

MULTI V 5 offers a diverse range of effective control solutions that satisfy specific needs of each building and its user scene. These controlling systems are equipped with user friendly interface, flexible interlocking environment, energy management and smart individual controller for optimised controlling conditions and smart building management.

## HOTEL

Hotel Room Solution



## OFFICE

Central Control Solution



3<sup>rd</sup> Party BMS



Service/Maintenance

· Energy Management

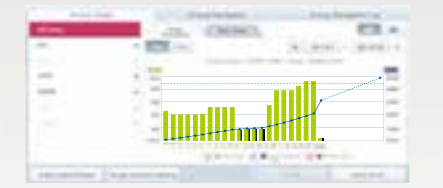

· External Device



- 15.8kW
- 10.6kW
- 7.1kW

## APARTMENT

Power Distribution Solution



## RESIDENTIAL

Smart Individual Control Solution



## SMALL BUILDING

Small Central Control Solution



Integration Solution



reddot award  
User Interface Design

\*2016 AC Manager 5

# INDEX

7 - 55

## CONTROL SOLUTION

LG HVAC CONTROL LINE-UP	8
INDIVIDUAL CONTROL	10
CENTRALISED CONTROL	20
SYSTEM INTEGRATION DEVICE	29
OTHER INTEGRATION CONTROL SOLUTION	35



56 - 74

## ACCESSORIES

MECHANICAL ACCESSORIES	58
PIPING ACCESSORIES	63













# CONTROL SOLUTION























INDIVIDUAL CONTROL / CENTRALISED CONTROL  
SYSTEM INTEGRATION DEVICE / OTHER INTEGRATION CONTROL SOLUTION



# LG HVAC CONTROL LINE-UP

Individual Control			Centralised Control			
Wired Remote Controller			Wireless Remote Controller	Indoor Unit ~ 32	Indoor Unit ~ 128	Indoor Unit ~ 8,192
Premium	Standard	Simple				
 PREMTA000	Standard III (White)  PREMTB100	 PQRCVCL0QW	<b>NEW!</b>  PWLSSB21H		<b>NEW!</b> AC Smart 5  PACSSA000	AC Manager 5  PACM5A000
	Standard II (White)  PREMTB001	 PQRCHCA0QW (Simple for Hotel)				
			Wi-Fi controller	Indoor Unit ~ 64	Indoor Unit ~ 256	
			<b>NEW!</b> LG Wi-Fi Modem  For Indoor Unit PWFMD200	AC Ez Touch  PACEZA000	<b>NEW!</b> ACP 5  PACP5A000	

Centralised Control			Other Integration Device			
System Integration Device			Indoor Unit		Outdoor Unit	AHU Kit
Facility Integrator	Gateway for Protocol	PI-485	Dry Contact	Control Accessory		
 PDI (Power Distribution Indicator)  Premium (8port) PQNJD1S40 Standard (2port) PPWRDB000	 ACP Lonworks  PLNWKB000	 PI-485  For SINGLE / MULTI / THERMA V PMNFP14A1	 Simple Dry Contact PDRYCB000	 Group Control Wire  PZCWRCG3	 IO Module (Input / Output Module)  Demand Controller For MULTI V IV/S PVDSMN000	<b>NEW!</b> Communication Kit  Return/Room Air control PAHCMR000
 ACS I/O Module (Input / Output Module)  PEXPMB000	<b>NEW!</b> Modbus RTU Gateway  PMBUSB00A	 For Indoor Unit (Air-Conditioner, ERV) PHNFP14A0	 2 Points Dry Contact (For Setback) PDRYCB400	 Remote Temperature Sensor  PQRSTA0	 Dry Contact for Demand Control  Demand Controller for MULTI V III PQDSBCDVM0	<b>NEW!</b> Communication Kit  Discharge Air control PAHCMS000
			 Dry Contact for Thermostat PDRYCB300		 Variable Water Flow Control kit  For MULTI V WATER IV PWFCKN000	Control kit  PRCKD21E (~ 4 ODU) PRCKD41E (~ 8 ODU)
			 For Modbus PDRYCB500			EEV Kit (Electronic Expansion Valve)  PRLK048A0 (~ 28 kW) PRLK096A0 (~ 56 kW)
						TXV Kit (Thermal Expansion Valve)  PATX13A0E (22.4 - 44.8 kW) PATX20A0E (50.4 - 72.8 kW) PATX25A0E (78.4 - 100.8 kW) PATX35A0E (106.4 - 128.8 kW) PATX50A0E (134.4 - 156.8 kW)

\*AC Smart IV & AC Smart BACnet will be replaced by AC Smart 5  
\*ACP IV & ACP BACnet will be replaced by ACP 5  
\*KNX Gateway is provided by INTESIS

# INDIVIDUAL CONTROL SOLUTION

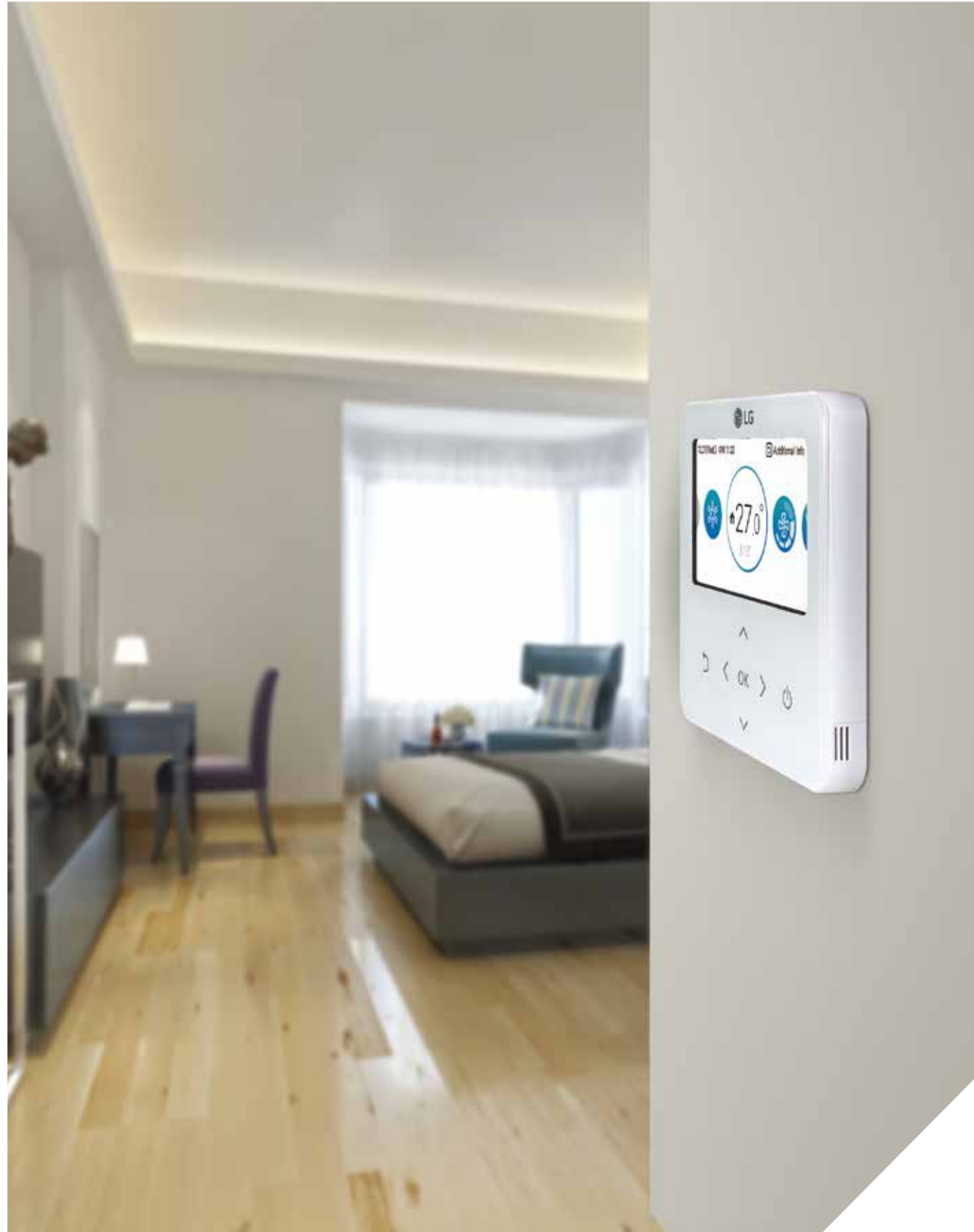

## INDIVIDUAL CONTROL SOLUTION

### LINE-UP



### Remote Controller Line Up

Model Name	PREMTA000	PREMTB100	PREMTB001	PQRCVCL0QW PQRCVCL0Q PQRCHCA0QW PQRCHCA0Q	PWLSSB21H	PWFMDD200
On / Off	•	•	•	•	•	•
Mode Change	•	•	•	•*	•	•
Temperature Setting	•	•	•	•	•	•
Fan Speed Control	•	•	•	•	•	•
Auto Swing	•	•	•	•*	•	•
Vane Control (Louver Direction)	•	•	•	•*	•	•
Additional Mode Setting	•	•	•	•	•	-
E.S.P (External Static Pressure)	•	•	•	•	-	-
Reservation	Weekly / Yearly	Weekly / Yearly	Weekly	-	Sleep, On / Off	Weekly On / Off
Child lock / Total Lock	•	•	•	•	-	-
Advanced Lock (on/off, mode, set point range)	•	•	Mode only	-	-	-
Electric Failure Compensation	•	•	•	•*	-	•
Time Display	•	•	•	-	-	-
Filter Sign	•	•	•	-	-	•
Energy Monitoring**	•	•	•	-	-	•
2 Set Points Control	•	•	-	-	-	-
External Ports	-	DO 1	-	-	-	-

• Indoor unit needs to have functions requested by the controller

\* PQRCHCA0QW / PQRCHCA0Q doesn't offer this function

\*\* LG centralised controller(available from AC Ez Touch or higher model) with PDI (PQNUD1S40 / PPWRDB000) installation is required for this function

# STANDARD III WIRED REMOTE CONTROLLER

4.3 inch Color screen with a modern design

## PREMTB100 (White)



### Features <sup>1)</sup>

#### The Optimized Controller in MULTI V 5

- Humidity sensor embedded
- Comfort cooling setting
- Smart Load Control setting
- Outdoor unit low noise setting
- Defrost mode setting

#### New Modern Design & Easy interface

- Seamless design / Touch button
- 4.3 inch Color LCD / Intuitive GUI

#### External Device On/Off

- Customized Interlocking control with indoor status

#### 2 Set Points control <sup>2)</sup>

#### Multi Language support

English, French, German, Spanish, Italian, Portuguese, Polish, Czech, Russian, Chinese

Model Name	PREMTB100
On / Off	•
Fan Speed Control	•
Temperature Setting	•
Mode Change	Cooling / Heating / Auto / Dehumidification / Fan
Additional Mode Setting*	Plasma Purification / Energy-Saving Cooling / Robot Cleaning / Heater / Humidification / Comfort Cooling
Auto Swing	•
Vane Control (Louver direction)	•
E.S.P (External Static Pressure)**	•
Reservation	Simple / Sleep / On & Off timer / Weekly / Yearly / Holiday
Time Display	•
Electric Failure Compensation	•
Lock	All / On & Off / Mode / Set temperature range
Filter Sign	• (Remain time + Alarm)
Energy Management	Check Energy Usage*** / Check Operation Time / Target Setting (Energy, Operation Time) / Time Limit Operation / Alarm Popup / Initialization Usage Data
Operation Status LED	•
Indoor Temperature Display	•
Indoor Humidity Display	•
Display	4.3 inch TFT color LCD (480 x 272)
Size (W x H x D, mm)	120 x 120 x 16
Black light for Screen saver	•
Home Leave	2 set points control

\*It might not be indicated or operated at the partial product

\*\* This function is available for certain indoor unit type

\*\*\* LG centralised controller(available from AC Ez Touch or higher model) with PDI (PQNUD1S40 / PPWRDB000) installation is required for this function

1) Indoor unit needs to have functions requested by the controller

2) 2 set points control works normally with MULTI V Heat Recovery and Single Split Heat Pump. But in case of MULTI V Heat Pump, It may not work properly

### Fully Support MULTI V 5 functions



#### Inside Dual Sensing

Standard III remote controller can do sensing both Temperature and Relative Humidity.



#### Comfort Cooling

Without cooling operation stopping, this function allows MULTI V 5 IDU to maintain operation at mild cooling mode.

### Modern Design & Intuitive Interface



#### Colorful Icon

Standard III remote controller is possible to express various colors.



#### Weekly / Monthly / Yearly Trend & Target Setting control

Standard III remote controller provides convenient trend & target graph for different period.

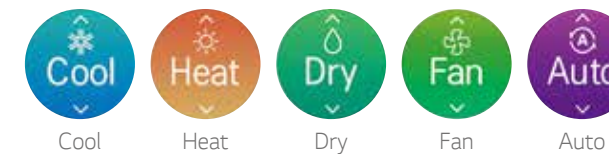

#### Easy Checking Schedule

Standard III remote controller provides clock type daily schedule.

### External Device On/Off



#### External Equipment Control

User can turn on or off the external equipment through contact point output.



#### Customised Interlocking Control

User can make control scenario. example) When temperature is under 10 degree, turn on the external heater.

### 2 Set Points Control



#### 2 Set Points Control

Ambient indoor temperature is guaranteed by setting two-point temperature for cooling and heating. Standard III remote controller automatically changes from heating to cooling (and vice versa) depending on temperature.



#### Home Leave

Changeable setting for occupied / unoccupied status

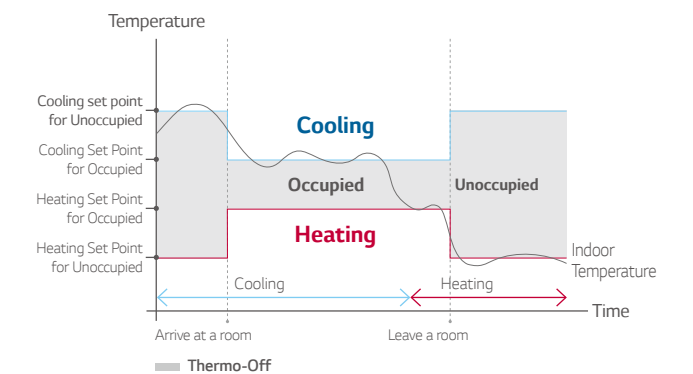

# PREMIUM WIRED REMOTE CONTROLLER

5 inch full touch screen with a premium design

## PREMTA000



### Features<sup>4)</sup>

#### Self-Management for Energy Saving

- Time limit operation / Power consumption monitoring
- Weekly / Monthly / Yearly trend tracking
- Target alert alarm
- Temperature range setting

#### Improved Scheduling

- Timer / Daily / Weekly / Yearly / Holiday

#### 2 Set Points Control<sup>5)</sup>

#### Design with User's Convenience

- Full touch / Intuitive GUI (Graphic User Interface)
- Main display simple mode / Touch buzzer

Model Name	PREMTA000
On / Off	•
Fan Speed Control	•
Temperature Setting	•
Mode Change	Cooling / Heating / Auto / Dehumidification / Fan
Additional Mode Setting*	Plasma Purification / Energy-Saving Cooling / Robot Cleaning / Heater / Humidification
Auto Swing	•
Vane Control (Louver direction)	•
E.S.P (External Static Pressure)**	•
Reservation	Simple / Sleep / On / Off / Weekly / Yearly / Holiday
Time Display	•
Electric Failure Compensation	•
Child Lock	•
Filter Sign	• (Remain time + Alarm)
Energy Management	Check Energy Usage*** / Check Operation Time / Target Setting (Energy, Operation Time) / Time Limit Operation / Alarm Popup / Initialization Usage Data
Operation Status LED	•
Indoor Temperature Display	•
Wireless Remote Controller Receiver	•****
Display	5 Inch TFT color LCD (480 x 272)
Size (W x H x D, mm)	137 x 121 x 16.5
Black Light for Screen Saver	•
Home Leave	2 Set Points Control

\*It might not be indicated or operated at the partial product

\*\* This function is available for certain indoor unit type

\*\*\* LG centralised controller(available from AC Ez Touch or higher model) with PDI (PQNUD1S40 / PPWRDB000) installation is required for this function

\*\*\*\* For ceiling type duct

4) Indoor unit needs to have functions requested by the controller

5) 2 set points control works normally with MULT V Heat Recovery and Single Split Heat Pump. But in case of MULTI V Heat Pump, It may not work properly

## Energy Management



### Self Energy Management

After it gathers information about usage time or electricity usage\*, offer periodical history data to users as visual information. By using various setting mode (operation hour / electricity usage etc.), you can manage on your own.



### Weekly / Monthly / Yearly Trend & Target Setting Control

Premium remote controller provides convenient trend & target graph for different period.



\* Centralised control (PACS4B000 / PACP4B000 / PQNFB17C0 / PLNWKB000) and PDI (PQNUD1S40 / PPWRDB000) should be installed for this function

## User Friendly Design



Standard Mode

### Intuitive UI & GUI Design

It is more easy to use and control various functions.



Simple Mode

### Display Configuration

Users can use of five buttons as shortcuts for frequently used features.

## Enhanced Schedule Function



Yearly Schedule

### Yearly / Weekly Schedule Function

If you set the schedule all at once, you will be able to effectively manage for various lengths of time. It provides 5 kinds of reservation functions. (Timer, Daily, Weekly, Yearly, Holiday)



Weekly Schedule Pattern

### Easy Pattern Schedule

It is possible to embody various schedules as pattern setting.



Weekly Schedule

\* Available to save up to a maximum of 20 error histories, 20 holiday reservations and 5 daily event on week

## 2 Set Points Control



### 2 Set Points Control

Ambient indoor temperature is guaranteed by setting two-point temperature for cooling and heating. New Standard III remote automatically changes from heating to cooling (and vice versa) depending on temperature.



### Home Leave

Changeable setting for occupied / unoccupied status

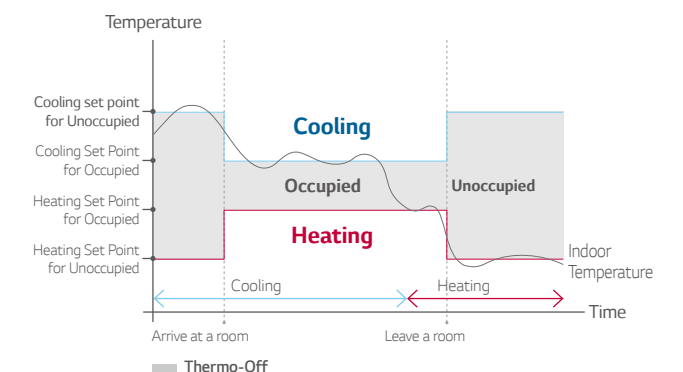



# STANDARD II WIRED REMOTE CONTROLLER

Providing easy control of one or a group of indoor units with various functions

STANDARD II

**PREMTB001 (White)**



## Features<sup>1)</sup>

Model Name	PREMTB001
On / Off	•
Fan Speed Control	•
Temperature Setting	•
Mode Change	Cooling / Heating / Auto / Dehumidification / Fan
Additional Mode Setting	Plasma Purification / Energy-Saving Cooling / Robot Cleaning / Heater / Humidification
Auto Swing	•
Vane Control (Louver direction)	•
E.S.P (External Static Pressure)	•
Reservation	Simple / Sleep / On / Off / Weekly / Holiday
Time Display	•
Electric Failure Compensation	•
Child Lock	•
Filter Sign	• (Remain time + Alarm)
Operation Status LED	•
Indoor Temperature Display	•
Wireless Remote Controller Receiver	•*
Size (W x H x D, mm)	120 x 120 x 16
Blacklight	•
Power Consumption Monitoring	•**
Check Model Information	•

\* For ceiling type duct

\*\* LG centralised controller(available from AC Ez Touch or higher model) with PDI (PQNUD1S40 / PPWRDB000) installation is required for this function

1) Indoor unit needs to have functions requested by the controller

# SIMPLE WIRED REMOTE CONTROLLER

A simple way to control office or hotel systems in a compact design

SIMPLE

**PQRCVCLOQW (White)**

SIMPLE FOR HOTEL

**PQRCHCA0QW (White)**



Simple



Simple for Hotel

## Features<sup>1)</sup>

Model Name	PQRCVCLOQW	PQRCHCA0QW
On / Off	•	•
Fan Speed Control	•	•
Temperature Setting	•	•
Mode Change	Cooling / Heating / Auto / Dehumidification / Fan	Only Changeable by Central Controller
Auto Swing	•	-
Vane Control (Louver direction)	•	-
E.S.P (External Static Pressure)	•	•
Electric Failure Compensation	•	-
Child Lock	•	•
Indoor Temperature Display	•	•
Wireless Remote Controller Receiver	•*	•*
Size (W x H x D, mm)	68 x 120 x 16	68 x 120 x 16
Blacklight	•	•

\* For ceiling type duct

1) Indoor unit needs to have functions requested by the controller

# WIRELESS REMOTE CONTROLLER

## PWLSSB21H



### Features

Model Name	PWLSSB21H
On / Off	•
Fan Speed Control	•
Temperature Setting	•
Mode Change	Cooling / Heating / Auto / Dehumidification / Fan
Additional Mode Setting	Plasma Purification / Energy-Saving Cooling / Robot Cleaning / Auto Dry
Auto Swing	•
Vane Control (Louver direction)	•
Reservation	Sleep / On / Off
Indoor Temperature Display	•
Sleep Mode Auto	Max. 7 hours
Size (W x H x D, mm)	51.4 x 153 x 26

# LG WI-FI MODEM

Control LG air conditioners via using the internet devices as Android or iOS bases smartphones.

## PWFMDD200



### Features

- Access LG air conditioner anytime and from anywhere with iOS or Android compatible devices
- LG's exclusive Home Appliances control app(SmartThinQ) is available
- Simple operation for various functions
  - On/Off
  - Fan Speed
  - Energy Monitoring<sup>1)</sup>
  - Operation Mode
  - Vane Control<sup>2)</sup>
  - Filter Management
  - Current/Set Temperature
  - Reservation (Sleep, Weekly On/Off)
  - Error check

Model Name	PWFMDD200
Size (W x H x D, mm)	48 x 68 x 14
Interfaceable Products	Multi V Indoor unit <sup>3)</sup>
Connection Type	Indoor unit 1:1
Communication Frequency	2.4 GHz
Wireless Standards	IEEE 802.11b/g/n
Mobile Application	LG SmartThinQ (Android v4.1(Jellybean) or higher, iPhone iOS 9.0 or higher)
Optional Extension Cable	PWYREW000 (10m extension)

\* Functionality may be different according to each IDU model  
 \* User interface of application shall be revised for its design and contents improvement  
 \* Application is optimized for smartphone use, so it may not be well functioning with tablet devices  
 1) LG Centralised controller and PDI installation is required for this function  
 2) Vane Control may not be possible according to the type of Indoor unit  
 3) For the compatibility with Indoor unit, please contact regional office



### Overview

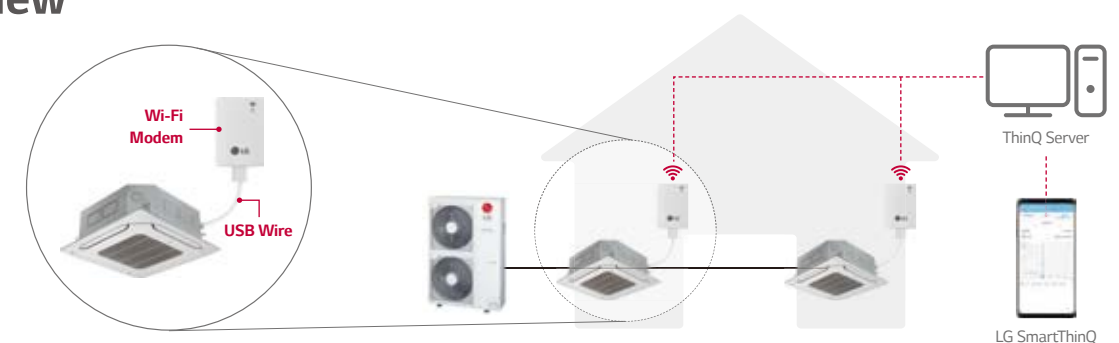

\* Search "LG SmartThinQ" on Google market or Appstore then download the app.  
 \* Internet service with Wi-Fi connection has to be available

# CENTRALISED CONTROL SOLUTION







## CENTRALISED CONTROL SOLUTION

### LINE-UP



### Central Controller Line Up

Model Name	PACEZA000	PACSSA000	PACP5A000	PACMSA000
				
Maximum number of units	64	128	256	8,192
Individual / Group Control	•	•	•	•
Individual Controller Lock	•	•	•	•
Error Check	•	•	•	•
Slave Mode (Interlocking with higher level controller)	•	•	-	-
Schedule	Yearly	Yearly	Yearly	Yearly
Remote Access	By client S/W	Web	Web	Web
Emergency Stop & Alarm Display	•	•	•	•
Power Consumption Monitoring (with PDI)	•	•	•	•
Auto Changeover / Setback	•	•	•	•
Temperature Limit	•	•	•	•
Operation Time Limit	-	•	•	•
Visual Navigation	-	•	•	•
Operation Trend	-	•	•	•
Interlock Control	-	•	•	•
Virtual Group Control	-	•	•	•
ODU Capacity Control*	-	•	•	•
Energy Navigation (with PDI)	-	•	•	•
ACS IO Module Interlocking	-	•	•	•
<b>NEW!</b> BMS Integration (BACnet, Modbus protocol)	-	• (PACSSA000 only)	• (PACP5A000 only)	-
<b>NEW!</b> IPv6 Support	•	• (PACSSA000 only)	• (PACP5A000 only)	-

\* This function is available for certain product



# AC SMART 5

All-in-One solution for BMS integration up to 128 units via BACnet and Modbus protocol as well as its own smart management function with touch screen interface

## PACS5A000



## Features

Model Name	PACS5A000
Size (W x H x D, mm)	253.2 x 167.7 x 28.9
Interfaceable Products	MULTI V / ERV / ERV DX / Hydro kit / THERMA V / AHU kit / LG Chiller <sup>1)</sup>
Maximum number of units	128
Individual / Group Control	On & Off / Mode / Temperature / Fan speed
Individual Controller Lock	Temperature / Mode / Fan speed / All
Advanced Function Setting and Display <sup>2)</sup>	Comfort Cooling / ODU Low Noise / ODU Defrost Mode / Comfort Level display / CO <sub>2</sub> Level display (for ERV/ERV DX) / Night Time Free Cooling (for ERV/ERV DX)
Error Check	*
Slave Mode (Interlocking with higher level controller)	*
Schedule	Weekly / Monthly / Yearly / Exception day
Web Access	*
Emergency Stop & Alarm Display	*
Power Consumption Monitoring (with PDI)	*
Auto Changeover / Setback	*
Temperature Limit	*
Operation Time Limit	*
Visual Navigation	*
Operation Trend	*
Interlock Control	*
Virtual Group Control	*
ODU Capacity Control	*
Energy Navigation (with PDI)	*
Daylight Saving Time	*
ACS IO Module Interlocking	Max. 9
External IO Port	DI 2 / DO 2
BMS Integration <sup>3)</sup>	BACnet IP / Modbus TCP
IPv6 Support	*

1) Chiller Option Kit(PCHLLN000) is required 2) It is only available in some products 3) For the detail point list, please refer to the installation manual

## Installation Scene

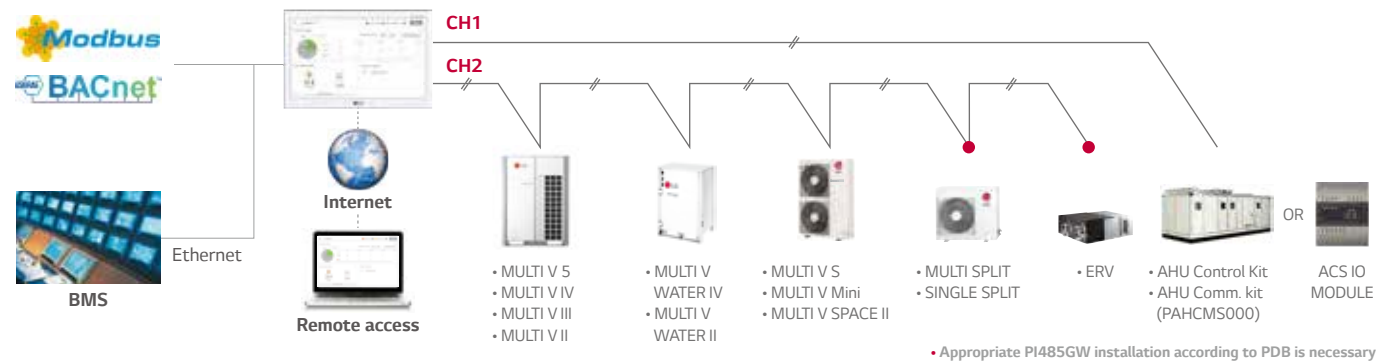

## Features

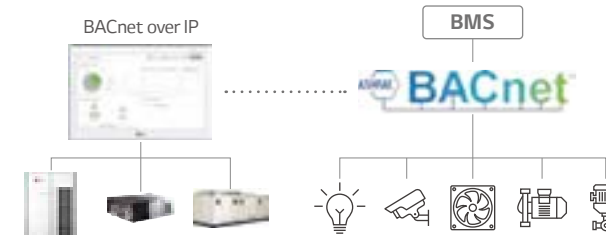

## BMS Integration

Without additional device, AC Smart 5 provides BACnet/IP and Modbus TCP/IP interface for BMS(Building Management System) integration as well as its own management function.



## Energy Management

Energy navigation function allows air conditioners operation to be managed under the monthly plan of energy usage. By analyzing present energy consumption and comparing with the plan, overuse of system operational costs can be prevented.

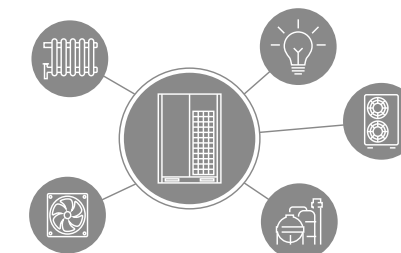

## Device Interlock

Building Facility can be interlocked with LG HVAC system on the automated control logic.

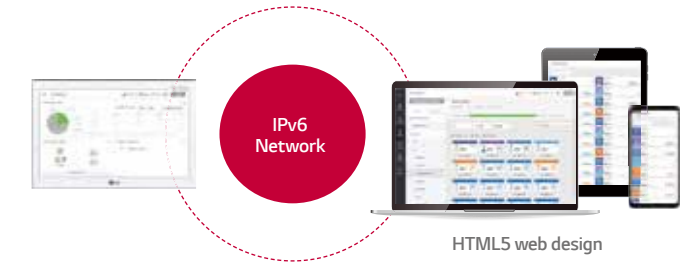

## Advanced Network Accessibility

AC Smart 5 reflects the state of the art of network technology trend. IPv6(Internet Protocol version 6), which is the most recent version of the Internet Protocol, provides accessibility to the IPv6 compatible network environment. HTML5 makes the web access to AC Smart 5 easier and look good on all devices, especially for mobile.



## Visualised Control

Visual navigation enables controlling and monitoring the unit on floor plan view for the intuitive management.



## Operation Trend

Unit's operation status change in the past can be traced to help establishing reasonable operation plan of the site.

# AC EZ TOUCH

Smart management with 5 inch touch screen for small site

## PACEZA000



## Features

Model Name	PACEZA000
Size (W x H x D, mm)	137 x 121 x 25
Interfaceable Products	MULTI V / ERV / ERV DX / Hydro kit / THERMA V
Maximum number of units	64
Individual / Group Control	On & Off / Mode / Temperature / Fan speed
Individual Controller Lock	Temperature / Mode / Fan speed / All
Error Check	.
Slave Mode (Interlocking with higher level controller)	.
Schedule	Weekly / Monthly / Yearly / Exception day
Remote Access	By client S/W
Emergency Stop & Alarm Display	.
Power Consumption Monitoring (with PDI)	.
Auto Changeover / Setback	.
Temperature Limit	.
Operation History	Error
ODU Low Noise <sup>1)</sup>	.
Daylight Saving Time	.
External IO Port	DI 1
IPv6 Support	.

1) It is only available in some products

## Installation Scene

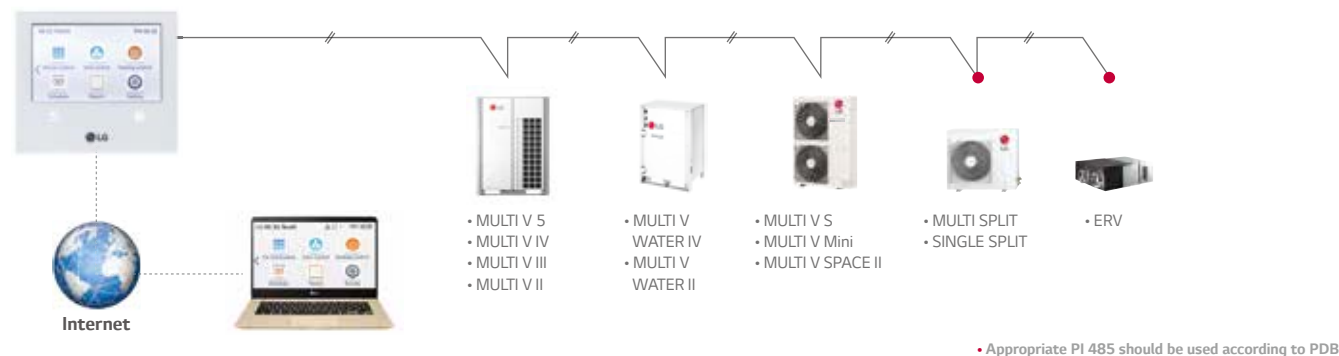

## Features



### PC Access

Users can control each space efficiently through PC access.



### Energy Mode

When using energy mode function, operation mode changes from cooling to fan or heating to off mode by force. (It is available only air conditioner and 'on' mode indoor unit)

Energy		
2016. 2. 8 ~ 2016. 3. 19		
Today Week Month		
Name	Usage(kWh)	Accumulated(kWh)
Group1	110	3021
Group2	150	6186
Group3	130	4267
Group4	120	7614

### Energy Statistics (with PDI)

Statistics of operational status (time, power consumption) are provided to help make intelligent system operation decisions.

Schedule_Month						
Sun	Mon	Tue	Wed	Thu	Fri	Sat
28	29	1	2	3	4	5
6	7	8	9	10	11	12
13	14	15	16	17	18	19
20	21	22	23	24	25	26
27	28	29	30	31	1	2
3	4	5	6	7	8	9

### Schedule

Schedule control allows user to set the events in advance to maximise system performance. Also, by blocking unnecessary operation, it prevents a waste of energy.

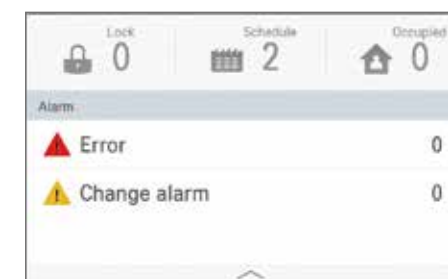

### Alarm Indicator

It works when there are some errors or it's time to change the filter. Users can respond immediately according to alarm indicator therefore HVAC system is monitored consistently.



### Group / Individual Control

According to the situation, it can be controlled by group or each indoor unit. It is useful to monitor or control for the best fit of request.

# ACP 5

Advanced solution for BMS integration up to 256 units via BACnet and Modbus protocol as well as its own smart management function with web server interface

## PACP5A000



### Features

Model Name	PACP5A000
Size (W x H x D, mm)	270 x 155 x 65
Interfaceable Products	MULTI V / ERV / ERV DX / Hydro kit / THERMA V / AHU kit / LG Chiller <sup>1)</sup>
Maximum number of units	256
Individual / Group Control	On & Off / Mode / Temperature / Fan speed
Individual Controller Lock	Temperature / Mode / Fan speed / All
Advanced Function Setting and Display <sup>2)</sup>	Comfort Cooling / ODU Low Noise / ODU Defrost Mode / Comfort Level display / CO <sub>2</sub> Level display (for ERV/ERV DX) / Night Time Free Cooling (for ERV/ERV DX)
Error Check	.
Schedule	Weekly / Monthly / Yearly / Exception day
Web Access	.
Emergency Stop & Alarm Display	.
Power Consumption Monitoring (with PDI)	.
Auto Changeover / Setback	.
Temperature Limit	.
Operation Time Limit	.
Visual Navigation	.
Operation Trend	.
Interlock Control	.
Virtual Group Control	.
ODU Capacity Control	.
Energy Navigation (with PDI)	.
Daylight Saving Time	.
ACS IO Module Interlocking	Max. 16
External IO Port	DI 10 / DO 4
BMS Integration <sup>3)</sup>	BACnet IP / Modbus TCP
IPv6 Support	.

1) Chiller Option Kit (PCHLLN000) is required 2) It is only available in some products 3) For the detail point list, please refer to the installation manual

### Installation Scene

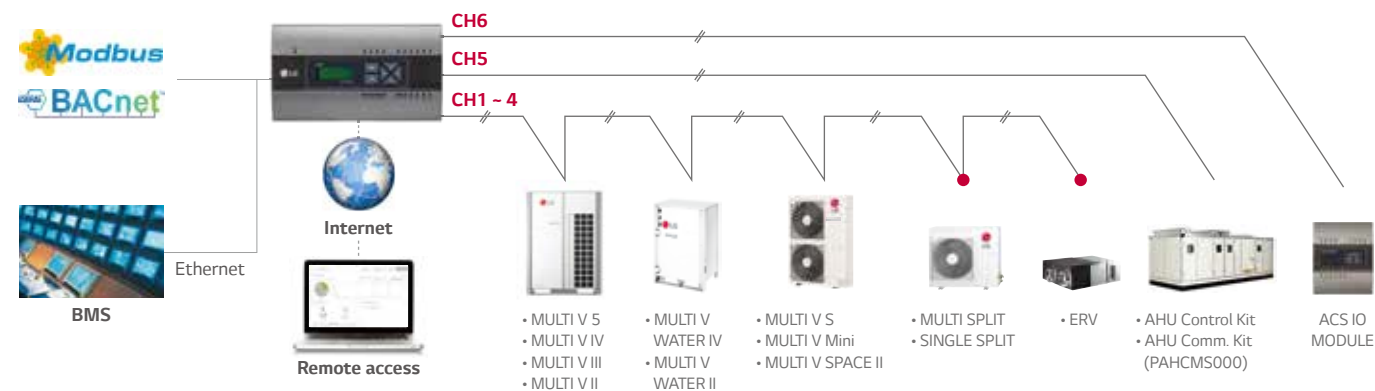

• Appropriate PI485GW installation according to PDB is necessary

# AC MANAGER 5

Multiple ACP and AC Smart integration solution to manage multi sites up to 8,192 units as a single system

## PACM5A000



reddot award  
User Interface Design



### Features

Model Name	PACM5A000*
Size (W x H x D, mm)	270 x 155 x 65
Interfaceable Products	MULTI V / ERV / ERV DX / Hydro kit / THERMA V / AHU kit / LG Chiller <sup>1)</sup>
Maximum number of units	8,192 (supports 32 ACP IV/5 or AC Smart IV/5)**
Individual / Group Control	On & Off / Mode / Temperature / Fan speed
Individual Controller Lock	Temperature / Mode / Fan speed / All
Error Check	.
Schedule	Weekly / Monthly / Yearly / Exception day
Web Access	.
Emergency Alarm Display	.
Power Consumption Monitoring (with PDI)	.
Auto Changeover / Setback	.
Temperature Limit	.
Operation Time Limit	.
Visual Navigation	.
Operation Trend	.
Interlock Control	.
Virtual Group Control	.
ODU Capacity Control	.
Energy Navigation (with PDI)	.
ACS IO Module Interlocking	.

\*AC Manager 5 requires ACP IV/5 or AC Smart IV/5  
1) Chiller Option Kit (PCHLLN000) is required

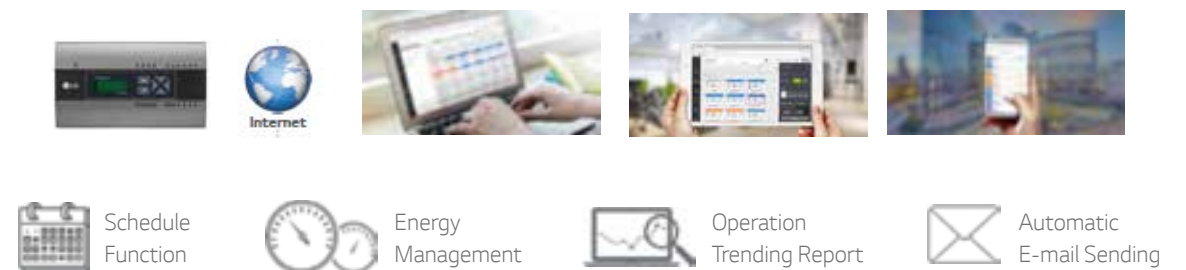







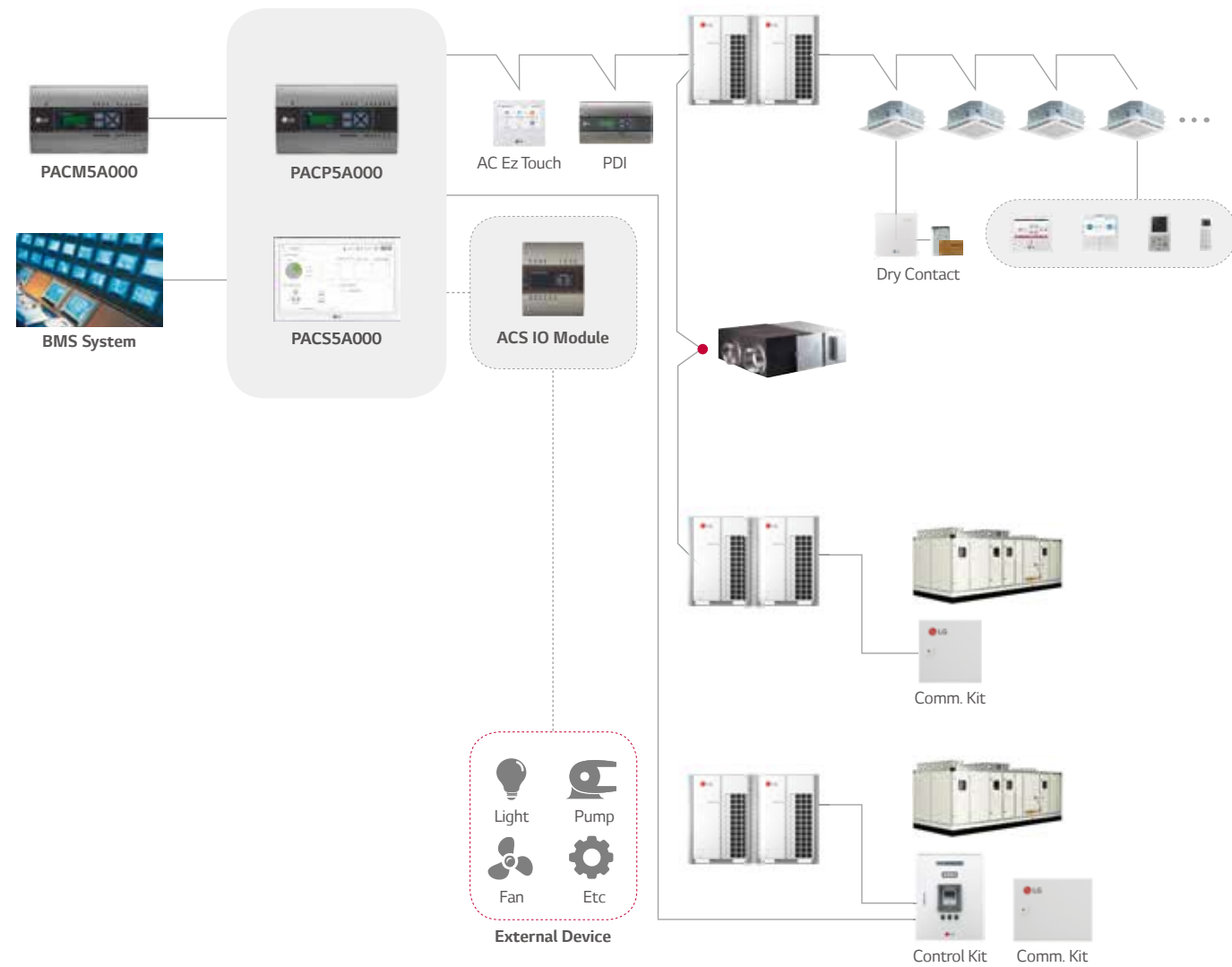

# AC MANAGER 5

# LINE-UP

## Solution Overview



Facility Integrator	Gateway for Protocol	PI-485
<p><b>PDI (Power Distribution Indicator)</b></p>  <p>Premium (8 port) PQNUD1540 Standard (2 port) PPWRDB000</p>	<p><b>ACP Lonworks</b></p>  <p>PLNWKB000</p>	 <p>For Outdoor Unit (SINGLE / MULTI / THERMA V) PMNFP14A1</p>
<p><b>ACS I/O Module</b></p>  <p>PEXPMB000</p>	<p><b>Modbus RTU Gateway</b></p>  <p>PMBUSB00A</p>	 <p>For Indoor Unit (Air-Conditioner, ERV) PHNFP14A0</p>

• Appropriate PI 485 should be used according to PDB

# PDI (POWER DISTRIBUTION INDICATOR)

PDI shows distributed power consumption of up to 128 indoor units

**Premium**  
PQNUD1S40 (8 port)

**Standard**  
PPWRDB000 (2 port)



## Features

Model Name	PQNUD1S40	PPWRDB000
Size (W x H x D, mm)	270 x 155 x 65	
Interfaceable Products	Air conditioner, ERV DX	
Maximum Number of Power Meters	8	2
Maximum Number of Units	128	
Data Backup When Power Outage	-	
Power Input	PDI : AC 24V, Transformer : AC 220-240V	
Power Module Size (W x H x D, mm)	120 x 155 x 65	

## Installation Scene

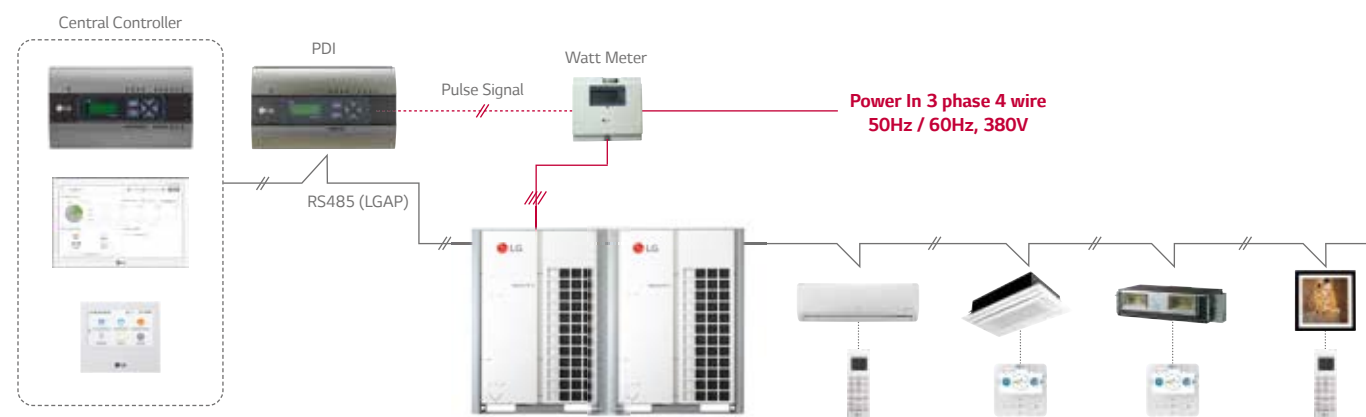

- Power Cable for 3 Phase 4 Wire
- Communication Cable (2 Wire Shielded Cable)
- Pulse Signal Wire

\* Power cable and type could be different from this scene depending on the Outdoor unit's specification  
 \* Measured power consumption could be different between PDI and Watt meter  
 \* Applicable Central Controller : ACP series (IV/5/BACnet/Lonworks), AC Smart series (IV/5/BACnet), AC Ez Touch  
 Combination : we recommend you to connect separated watt meter for Outdoor units to have correct power distribution value

# ACS I/O MODULE

This module can be connected with ACP IV/5 or AC Smart IV/5 controller if additional I/O points such as DI/DO and AI/AO for 3rd party devices control and monitoring are needed.

**PEXPMB000**



## Features

Model Name	PEXPMB000	
Linkable Products	PACS4B000 PACS5A000 PACP4B000 PACP5A000	
Communication	RS-485	1
I/O	Digital Input	3
	Digital Output	3
	Universal Input <sup>1)</sup>	4
	Analog Output	4

Model Name	Min.	Max.	
Analog Input	NTC 10k	0.68k Ω	177k Ω
	PT 1000	803 Ω	1,573 Ω
	Ni 1000	871.7 Ω	1,675.2 Ω
	DC (Voltage)	0V	10V
Analog Output	DC (Current)	0mA	20mA
	-	0V	10V
Digital Input	Binary Input (Non Voltage)	-	-
Digital Output	Normal open	-	30VAC / 30VDC, 2A

	PACS4B000	PACP4B000	PAC5A000
Number of Indoor Units	64 - 128	128 - 256	8,192
Max. I/O Points	130	238	1,260
Maximum Number of Node	9	16	-

\* Maximum number of Indoor units may be reduced by increasing the number of I/O points.  
 1) The type of UI (Universal Input) is selectable among Digital Input and Analog Input

## Installation Scene

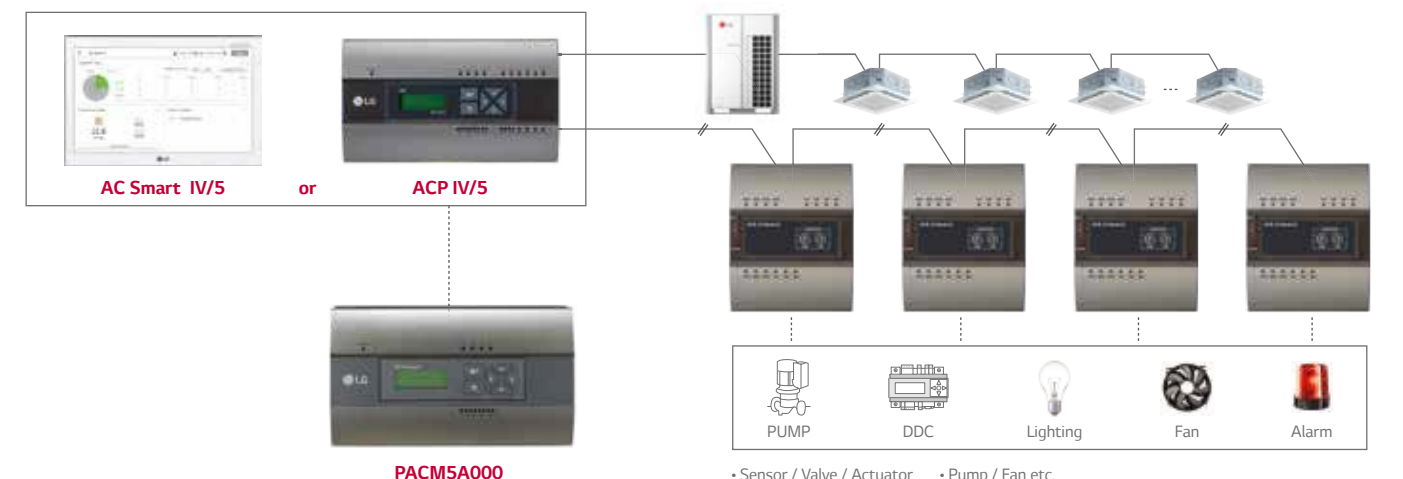

\* DI : Digital Input, DO : Digital Output, UI : Universal Input, AO : Analog Output / Please contact our regional office to have connectable relay specification for analog output  
 \* The type of UI (Universal Input) is selectable among Digital Input and Analog Input

# ACP LONWORKS GATEWAY

PLNWKB000



## Features

- **Process Ability**
  - EHP Type : 64 units (Indoor / ERV / Hydro Kit / THERMA V)
  - AHU Control kit : Maximum 16 units
- **Connect to use Lonworks® protocol and LG air conditioner protocol.**
- **Self installation verification function using internet (Web Server Included)**
  - Setting gateway
  - Diagnosis of communication status on LG Air-conditioner network
- **It offers a variety of functions as ACP which allows the customer to efficiently control various types of equipment from the customer's own Integration.**

Controlling	Monitoring Items
On / Off Command	On / Off Status
Operation Mode Setting	Operation Mode Status
Fan Speed Setting	Fan Speed Status
Lock Setting	Lock Status
Air Flow Setting	Air Flow Setting
Set Temperature Setting	Set Temperature Status
-	Current Space Temperature Status
-	Error Status
-	Accumulator Power Distribution Status
Upper Limit Temperature Setting	Accumulator Power Distribution Status
Low Limit Temperature Setting	Low Limit Temperature Setting
Mode Lock Setting	Mode Lock Status
Peak Operation Ratio Setting	Peak Operation Ratio Setting
All On / Off Setting	-
-	Total Accumulate Power Status

## Installation Scene

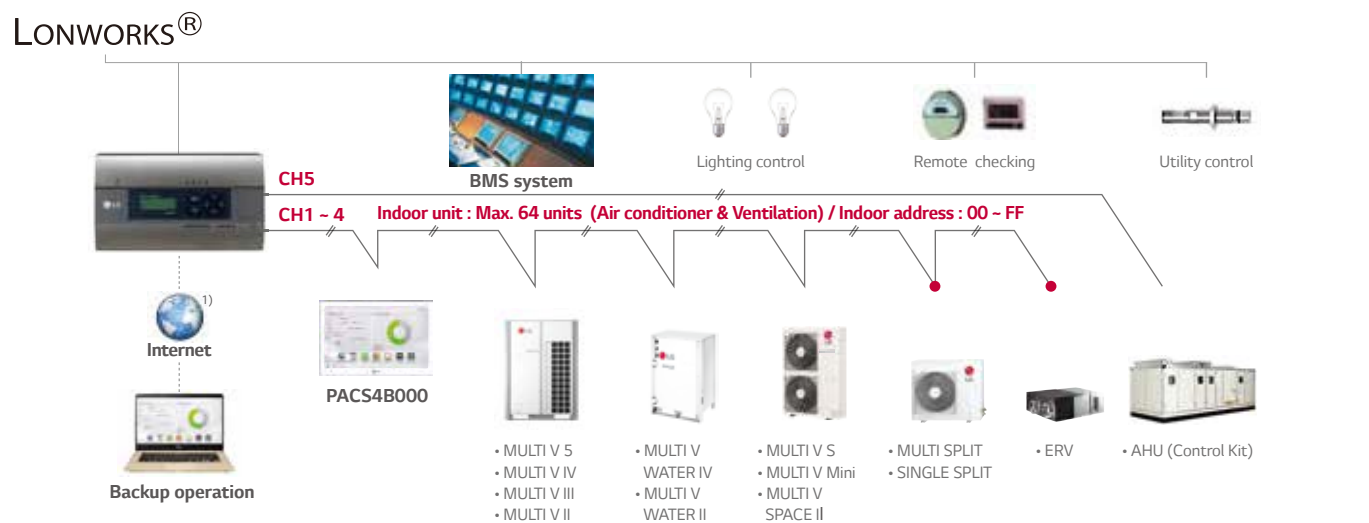

1) Assignment of public IP address is required to access central controller through internet.

• Appropriate PI 485 should be used according to PDB

# MODBUS RTU GATEWAY

PMBUSB00A



## Features

- **Function**
  - MODBUS RTU communication with MODBUS master controller
  - Applicable for MULTI V
  - Max. 16 IDUs with single module / Max. 64 IDUs with 4 modules
  - MODBUS RTU slave (RS485) / 9,600 bps
  - Size (W\*H\*D) : 53.6 x 89.7 x 60.7
  - Power : DC 12V
- **Modbus Memory Map\***

Register	Read	Write	Description	Notes
00001	•	•	Operation	0 : Off / 1 : On
00002	•	•	Total Lock	0 : Unlock / 1 : Lock
00005	•	•	Auto Swing	0 : Manual / 1 : Auto
00006	•	•	Operation Mode Lock	0 : Unlock / 1 : Lock
00007	•	•	Fan Speed Lock	0 : Unlock / 1 : Lock
00008	•	•	Set Temperature Lock	0 : Unlock / 1 : Lock
10001	•	-	Error Alarm	0 : Normal / 1 : Error
10002	•	-	Thermo On / Off	0 : Thermo Off / 1 : Thermo On
30001	•	-	Error Code	0 ~ 255
30002	•	-	Pipe In Temperature	Degrees C x 10
30003	•	-	Pipe Out Temperature	Degrees C x 10
30004	•	-	Room Temperature	Degrees C x 10
40001	•	•	Operation Mode	0 : Cooling / 1 : Dry / 2 : Fan / 3 : Auto / 4 : Heating
40002	•	•	Set Temperature	Degrees C x 10
40003	•	•	Fan Speed	1 : Low / 2 : Medium / 3 : High / 4 : Auto

## Installation Scene

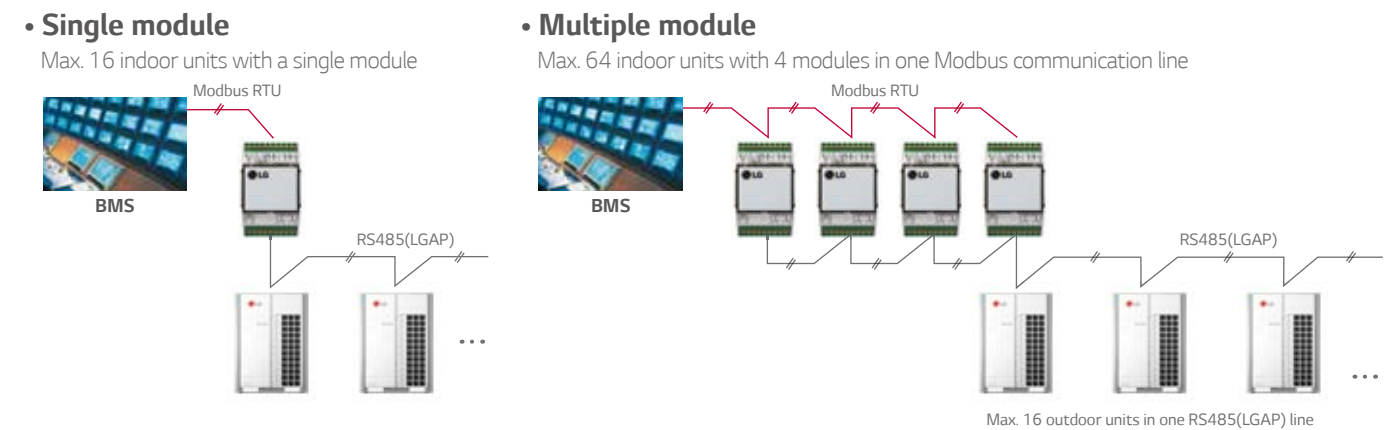



## PI 485

PI 485 converts LG air conditioner's protocol to the RS485 protocol for the central controller

### PMNFP14A1 / PHNFP14A0



### Features



- **Model Name : PMNFP14A1**
- **Power : Single Phase AC 220-240V 50/60Hz**
- **1 for Each Outdoor Unit**
  - MULTI V MINI (ARUN40GS2A / ARUV40GS2A Only needs PI485)
  - SINGLE SPLIT                      - MULTI SPLIT                      - THERMA V















- **Model Name : PHNFP14A0**
- **Power : Connected with the Indoor Units**
- **1 for Each Indoor Unit**
  - Indoor Unit (Air-Conditioner, ERV)

\* MULTI V PLUS II & MULTI V III & MULTI V IV series do not require any other PI 485 since these series have PI 485 in its outdoor unit PCB.

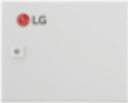
## OTHER INTEGRATION CONTROL SOLUTION



# LINE-UP

Indoor Unit		Outdoor Unit	AHU Kit
<b>Dry Contact</b> Simple Dry Contact  PDRYCB000	<b>Control Accessory</b> Group Control Wire  PZCWRCG3	IO Module (Input / Output Module)  PVDSMN000	Communication Kit  PAHCMR000
2 Points Dry Contact  PDRYCB400	Remote Temperature Sensor  PQRSTA0	Dry Contact for Demand Control  PQDSBCDVM0	 PAHCMS000
Dry Contact for Thermostat  PDRYCB300		Variable Water Flow Control Kit  PWFCKN000	Control Kit  PRCKD21E PRCKD41E
For Modbus  PDRYCB500			EEV Kit (Electronic Expansion Valve)  PRLK048A0 / PRLK096A0
			TXV Kit (Thermal Expansion Valve)  PATX13A0E / PATX20A0E PATX25A0E / PATX35A0E PATX50A0E

# DRY CONTACT

Connection between an indoor unit and external devices to control various functions

## PDRYCB000



## Features

Model Name	PDRYCB000
Contact Point	1 Contact Point
Contact Voltage Rating	AC 220-240V
On / Off Control	•
Error Alarm Output	•
Operation On / Off Output	•
Rotary Switch 1 (Set Temperature selection)	-
Rotary Switch 2 (Operation Logic selection)	-
Size (W x H, mm)	120 x 120

\* Refer to each models PDB for applicable models. \* Maximum operation AC : 3A  
 \* 4th generation indoor unit has 1 contact point function for On / Off control. But in case of using more function of Dry Contact besides On / Off control, Dry Contact is needed.

## Signal Point



## Installation Scene

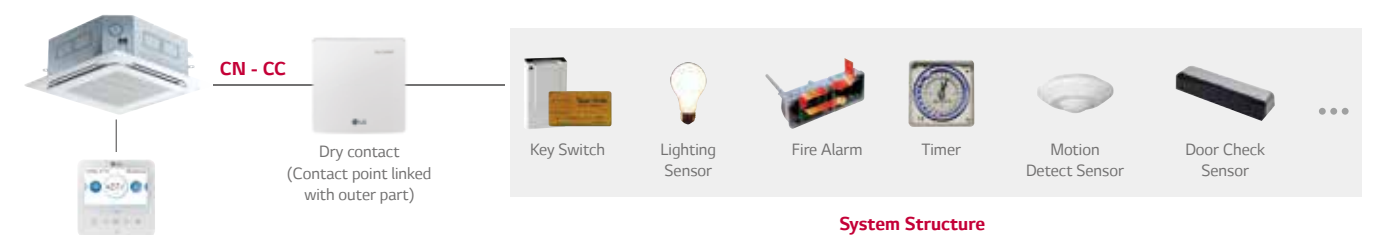

# DRY CONTACT

## PDRYCB400



### Features

Model Name	PDRYCB400
Contact Point	2 Contact Point
Contact Voltage Rating	DC 5 - 12V / Non Voltage
On / Off Control	•
Error Alarm Output	•
Operation On / Off Output	•
Rotary Switch 1 (Set Temperature selection)	•
Rotary Switch 2 (Operation Logic selection)	•
Size (W x H, mm)	120 x 120

\* Refer to each models PDB for applicable models. \* Maximum operation AC : 3A  
 \* 4th generation indoor unit has 1 contact point function for On / Off control. But in case of using more function of Dry Contact besides On / Off control, Dry Contact is needed.

### Signal Point



### Installation Scene

#### 2 inputs interworking

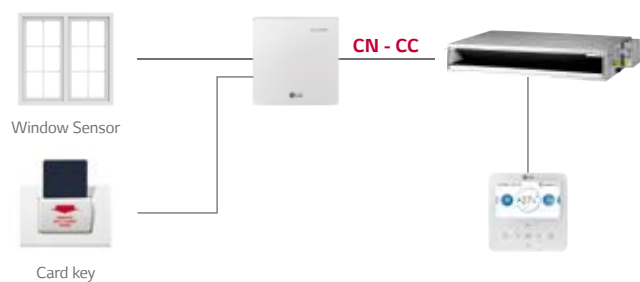

#### Refrigerant leakage detection alarm

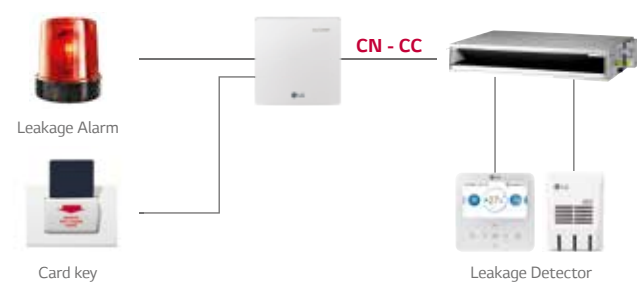

### Connection between an indoor unit and external devices to control various functions

## PDRYCB300



### Features

Model Name	PDRYCB300
Contact Voltage Rating	DC 5 - 12V / Non Voltage
On / Off Control	•
Mode Control	•
Fan Speed Setting	•
Thermo Off	•
Error Alarm Output	•
Operation On / Off Output	•
Rotary Switch 1 (Set Temperature Selection)	•
Rotary Switch 2 (Operation Logic Selection)	•
Size (W x H, mm)	120 x 120

### Signal Point



### Installation Scene



\* Please contact our regional office to have full compatible room controller list



# DRY CONTACT

## PDRYCB500



### Features

#### Function

- MODBUS communicate with MODBUS master controller
- MODBUS RTU slave / 2 wire RS485 / 9,600bps
- Max. 16 IDUs can be connected with one MODBUS master controller
- Size (W x H x D) : 120mm x 120mm x 36.5mm

#### Memory map

Register	Name	Range	Notes
00001	Operation	0 ... 1	0 : Stop, 1 : Run
30003	Indoor temperature	100 ... 400	Degrees C x 10
30100	Error alarm	0 ... 1	0 : No Error, 1 : Error
40001	Set run mode	0 ... 4	0 : Cooling, 1 : Dry, 2 : Fan, 3 : AI, 4 : Heating
40002	Set temperature	180 ... 300	Degrees C x 10
40015	Set fan speed	1 ... 3	1 : Low, 2 : Middle, 3 : High

### Installation Scene

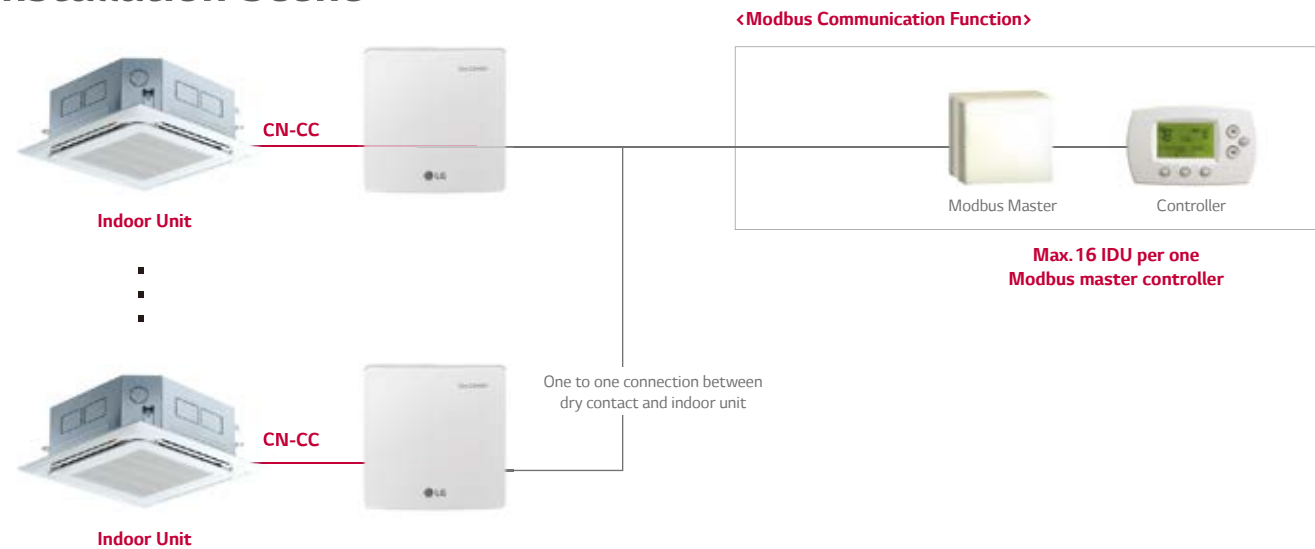

\* Please contact out regional office to check the compatibility with 3rd party room controller

# GROUP CONTROL WIRE

Cables used to connect a wired remote controller up to 16 indoor units

## PZCWRCG3



### Features

Model Name	PZCWRCG3
Y-type Cable	0.25m Length
Long Cable	9.6m Length

### Installation Scene

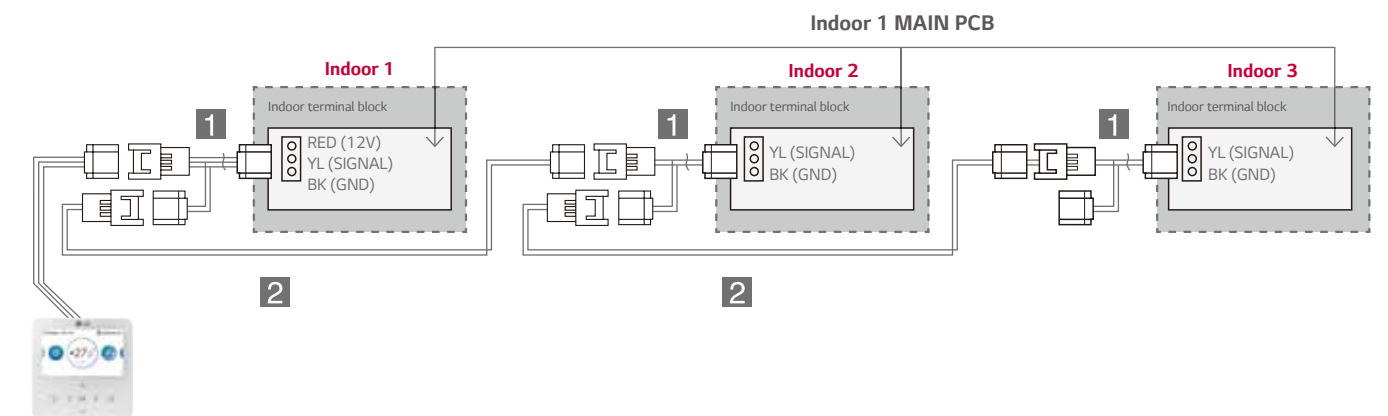

- Note:
- 1 Y type Cable assembly for connecting indoor unit and low cable.
  - 2 Long Cable assembly for connecting indoor to indoor.
- Please connect cable assembly Y type Cable with already connected indoor unit.

# REMOTE TEMPERATURE SENSOR

Sensor for detecting the room temperature

## PQRSTA0



### Features

- It detects the exact room temperature instead of indoor unit's air temperature sensor
- Applied to Ceiling Mounted Cassette, Ceiling Concealed Duct, THERMA V and Hydro Kit
- Extension cable (15m) is included

### Installation Scene

1. Wire to the control box in the indoor unit by removing the existing thermistor and connect the extension cable its place.
2. Cut the extension cable to the appropriate length and connect the screw terminal of the remote sensor.

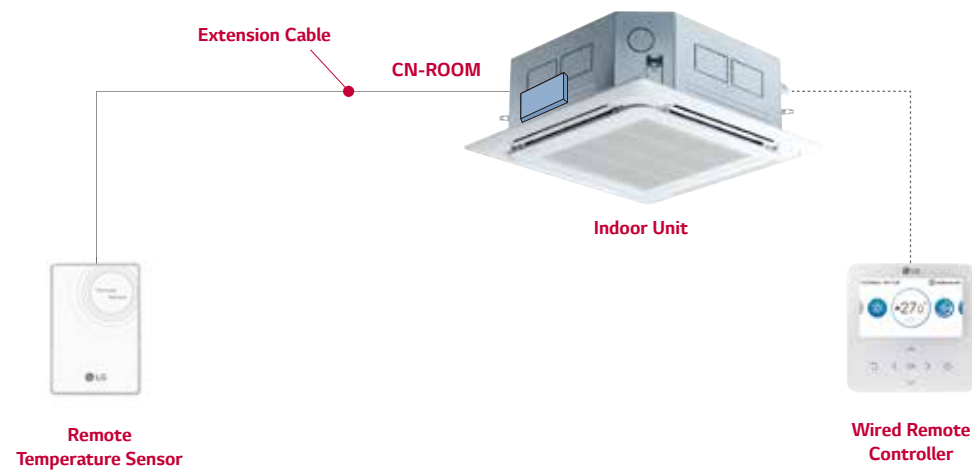

# IO MODULE

Interface module between system air conditioner's outdoor unit and external device

## PVDSMN000



### Features

#### Function

- Demand control
- Output outdoor or indoor unit operation status
- Low noise operation
- Output error status

#### Description

- IO Module is communication interface module for connection between MULTI V 5 and external IO (Input / Output Module) devices.

Note : IO Module is not compatible for MULTI V III

### Models Applied

- MULTI V 5
- MULTI V WATER IV
- MULTI V IV
- MULTI V S

#### Part Description

- 1) Digital Input Part (DI : Dry Contact Input)
  - Demand control by contact input (3 Step)
  - Low Noise Operation input
  - Priority Setting input :  
Setting the priority of demand control command (Capacity control for external signal from DDC vs Peak control by LG Central controller)
    - Open : External signal has priority to central controller (Default)
    - Close : Central controller has priority to external signal
- 2) Analog Input Part (AI : DC 0 ~ 10V)
  - Demand control by analog input (10 Step)
- 3) Digital Output Part (DO : 250VAC, Max 1A)
  - Error status relay output
  - Operation status relay output
  - Valve control

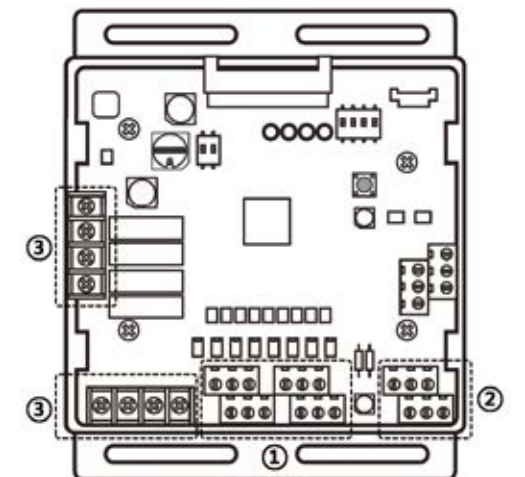

# IO MODULE

## Installation Scene

### Demand Control

Provides variable setting for demand control according to input method to reduce power consumption. This function supports 2 types of input signal : AI (0 ~ 10V, 10 Step) and contact signal (3 Step).

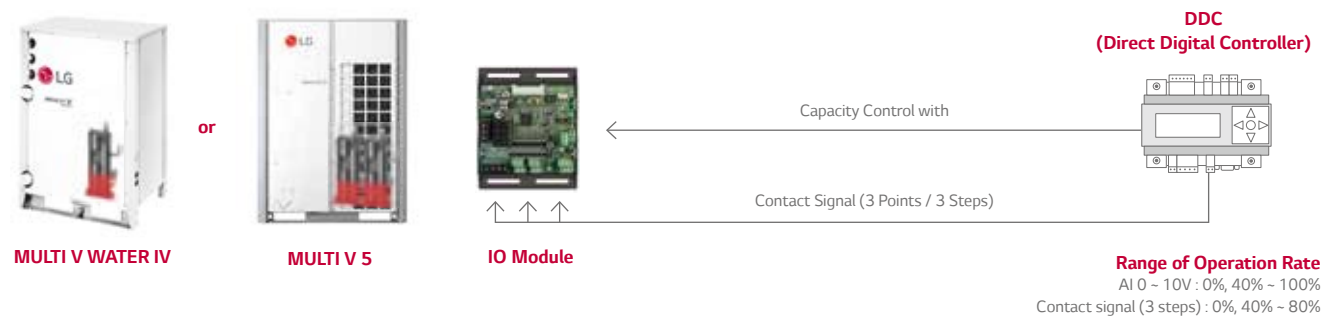

### Low Noise Operation

To reduce noise level, control outdoor unit's fan speed by dry contact input.

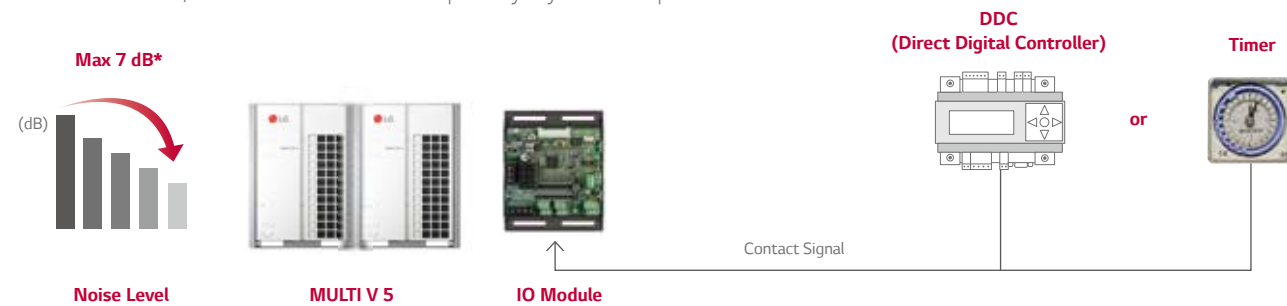

\* 8 HP model, Sound power level can be changed by outdoor unit operation status and low noise operation input signal.

### Refrigerant Leakage detection with Pump-down

For safety, IO module close refrigerant valve with Pump-down

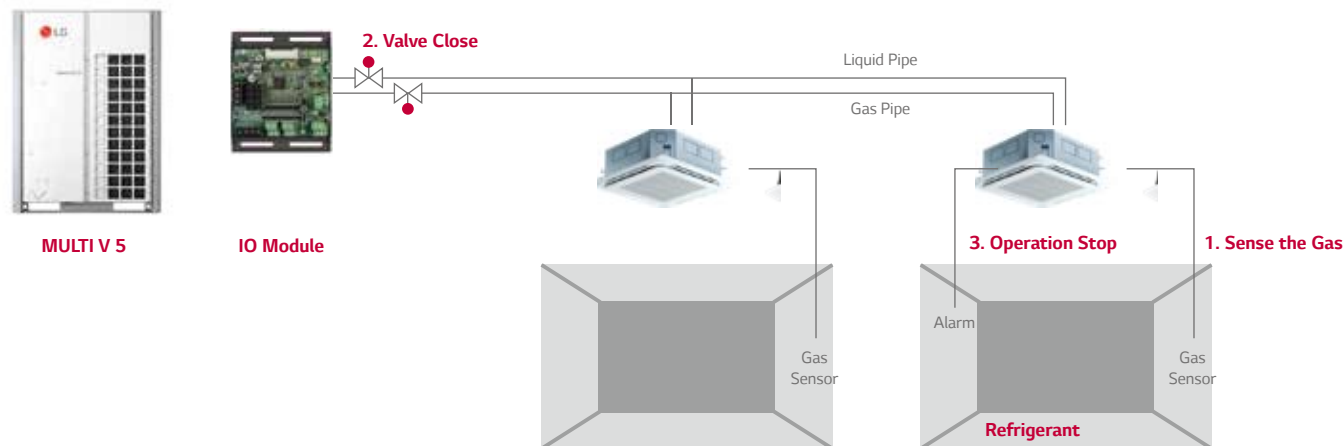

# VARIABLE WATER FLOW CONTROL KIT

Accessory developed for controlling the water flow

## PWFCKN000 (MULTI V WATER IV)



## Features

### Function

- Water pump or valve control (0 ~ 10V)
- Minimum output voltage setting available
- Operation, error output (250VAC, Max 1A)
- Dry contact input and analog output for demand control
- Digital output for operation, error status (250VAC, Max 1A)

### Advantage

- Water flow consumption reduction
- Pump electricity consumption reduction
- Including IO Module (Dry contact input, Analog input / output, Digital output)
- Using Dry contact and variable water flow control function simultaneously

## Wiring Diagram

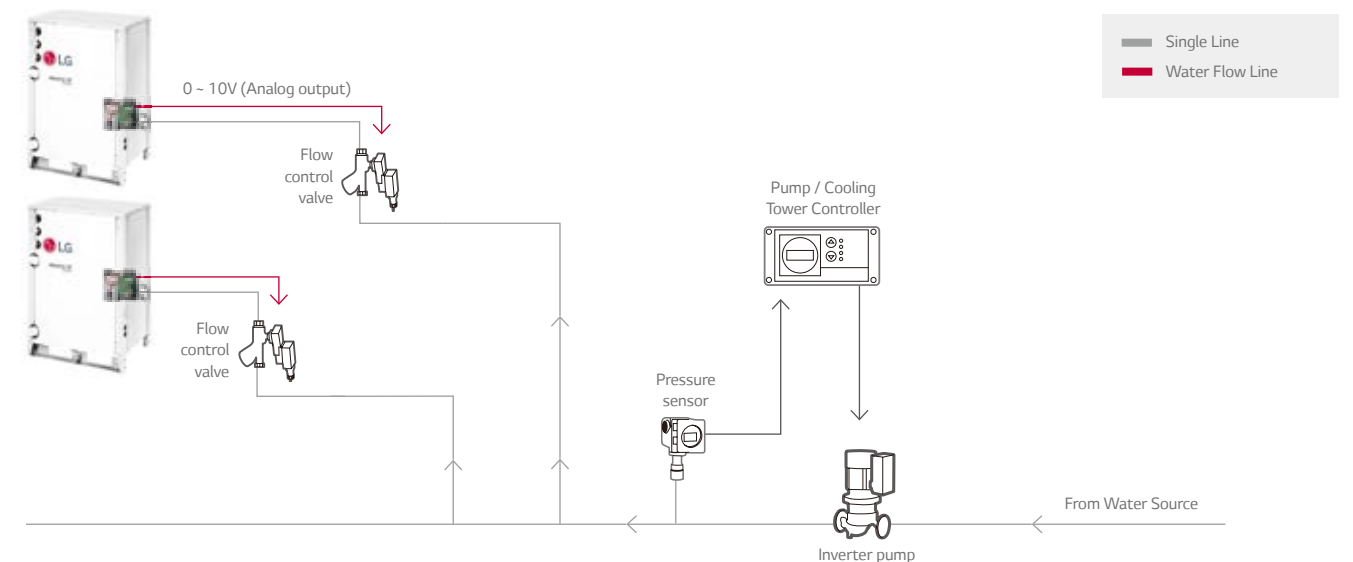

- Flow control valve : Regulates the flow or pressure of a fluid, normally responding to signals generated by independent devices.
- Flow Meter : Measures mass flow rate of a fluid traveling through a tube. (The mass flow rate is the mass of the fluid traveling past a fixed point per unit time.)
- Pressure Sensor : Measures the pressure.



# AHU KITS

A solution to connect LG's high efficiency system to the DX coil of an air handling unit for the maximum energy savings

## COMMUNICATION KIT

NEW! PAHCMR000 NEW! PAHCMS000



## CONTROL KIT

PRCKD21E / PRCKD41E



## EEV KIT

PRLK048A0  
PRLK096A0



## TXV Kit (Thermal Expansion Valve)

PATX13A0E / PATX20A0E  
PATX25A0E / PATX35A0E  
PATX50A0E



## Specifications

### Communication & Control Kit

Type	Model	Outdoor Unit	Combination			Description	Dimensions (mm)		
			EEV Kit	TXV Kit	Centralised Controller		W	H	D
Communication kit	PAHCMR000	Multi V	*	*	*	Return / room air temperature control by DDC or LG individual / centralised controller	300	300	155
		Single Split	-	-	*				
	PAHCMS000	Multi V	*	*	*	Discharge air temperature control by DDC or LG individual / centralised controller	380	300	155
		Single Split	-	-	*				
Control kit	PRCKD21E	Multi V	-	*	*	Max capacity 1-4 master outdoor unit	600	750	285
	PRCKD41E	Multi V	-	*	*	Max capacity 5-8 master outdoor unit	600	750	285

### Expansion Valves

Type	Model	Capacity Range	Pipe Diameter (mm)				Dimensions (mm)		
			Liquid (ODU)	Liquid (AHU)	Gas (ODU)	Gas (AHU)	W	H	D
EEV Kit (Electronic Expansion Valve)	PRLK048A0	2.6 - 28.0 kW	12.7	12.7	-	-	217	404	83
	PRLK096A0	33.6 - 56.0 kW	12.7	12.7	-	-	217	404	83
TXV Kit (Thermal Expansion Valve)	PATX13A0E	22.4 - 44.8 kW	15.88	15.88	22.22	22.22	491	238	174
	PATX20A0E	50.4 - 72.8 kW	15.88	22.22	28.58	28.58	491	238	174
	PATX25A0E	78.4 - 100.8 kW	22.22	28.58	34.92	34.92	491	238	174
	PATX35A0E	106.4 - 128.8 kW	28.58	34.92	41.3	41.3	491	238	174
	PATX50A0E	134.4 - 156.8 kW	28.58	34.92	41.3	41.3	561	291	192

## Communication Kit

### HIGH ENERGY EFFICIENCY

LG's DX AHU solutions are capable of performing all indoor air conditioning tasks with success under all operating conditions thanks to their superior performance with high efficiency heat source system.

Solution benefits offer the following advantages:

- High energy efficiency inverter system
- Large range of expansion valves  
: 3.6 ~ 56 kW EEV Kit, 22.4 ~ 156.8 kW TXV Kit
- Connected to various heat sources  
: MULTI V, MULTI V WATER, MULTI V S, SINGLE SPLIT



### DIVERSE OPTIONS FOR CONTROL

AHU communication kit can be connected to various control system such as LG individual/central controller and DDC\*. It can be directly connected to DDC without separated controller, so DDC can receive product control and monitor information through contact signal or Modbus protocol.

- Direct wiring between DDC and AHU communication kit
  - Embedded Digital I/O and Analog Input
  - Modbus RTU protocol supported
- LG Individual/Central controller supported
  - LG controller stand alone or combination with DDC

\*DDC : Direct Digital Controller

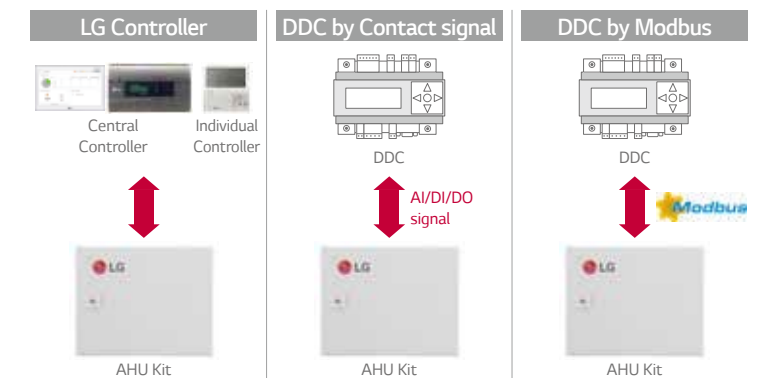

### EXPANDABLE SYSTEM DESIGN

LG AHU system can be a suitable solution for various sites due to its application flexibility and wide range of line up with large capacity models. According to the required capacity, a single or multiple module combination is possible thanks to AHU communication kit's modular design.

- Multiple module combination for large capacity AHU

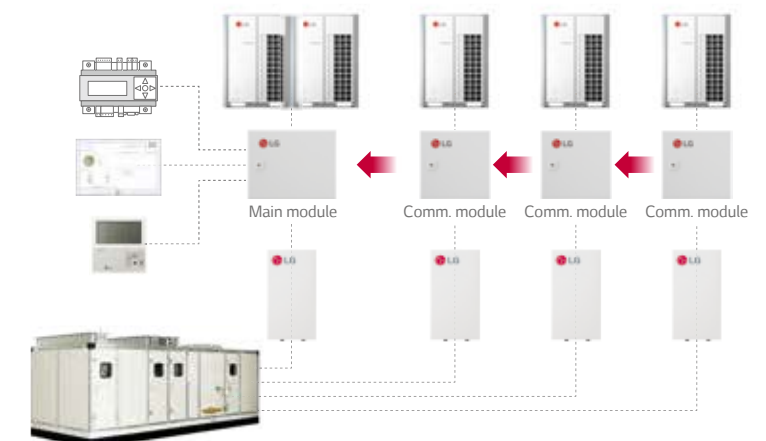

# AHU KITS

## Communication Kit Application

### Small Capacity with Single Split + Return / Room Air Temperature Control

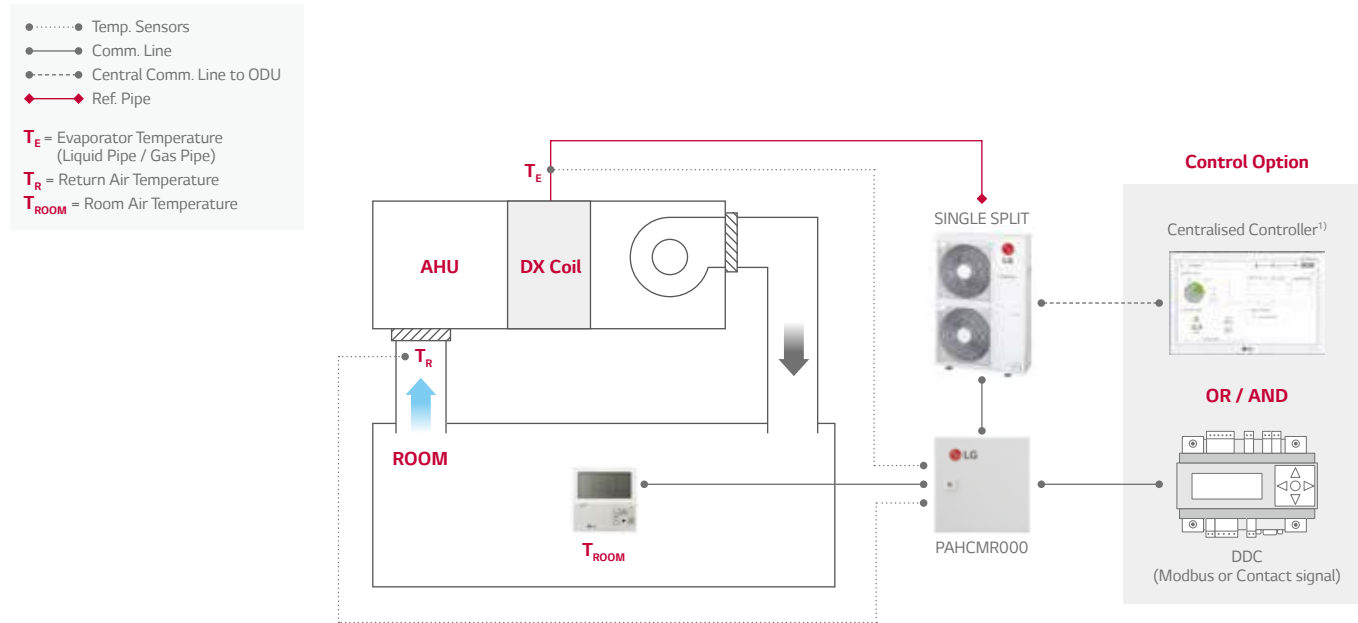

## Communication Kit Application

### Small-Medium Capacity with MULTI V + EEV Kit + IDU + Return / Room Air Temperature Control

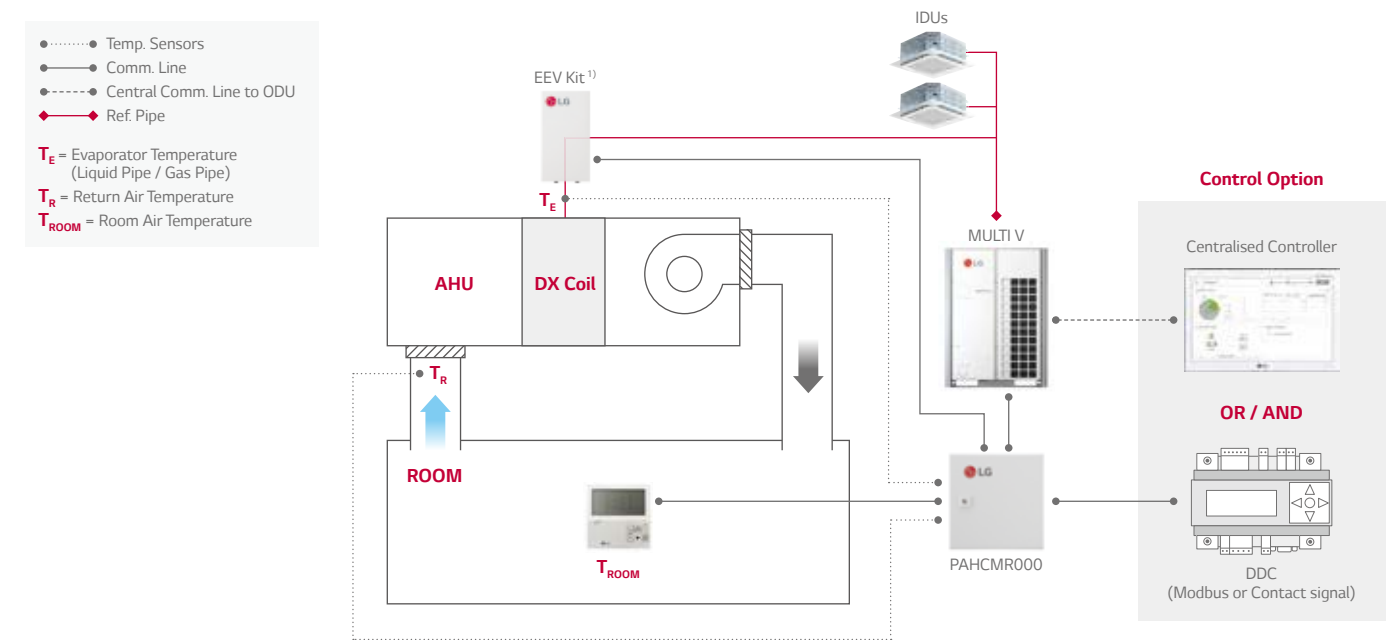

### Small Capacity with Single Split + Discharge Air Temperature Control

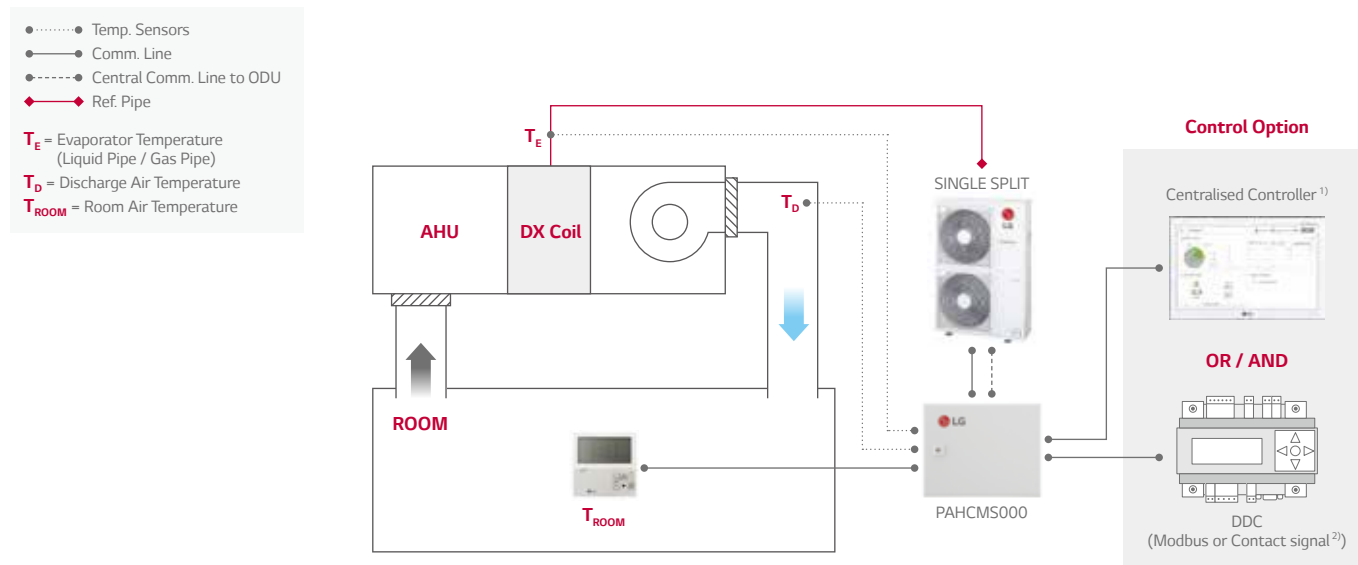

### Small-Medium Capacity with MULTI V + EEV Kit + Discharge Air Temperature Control

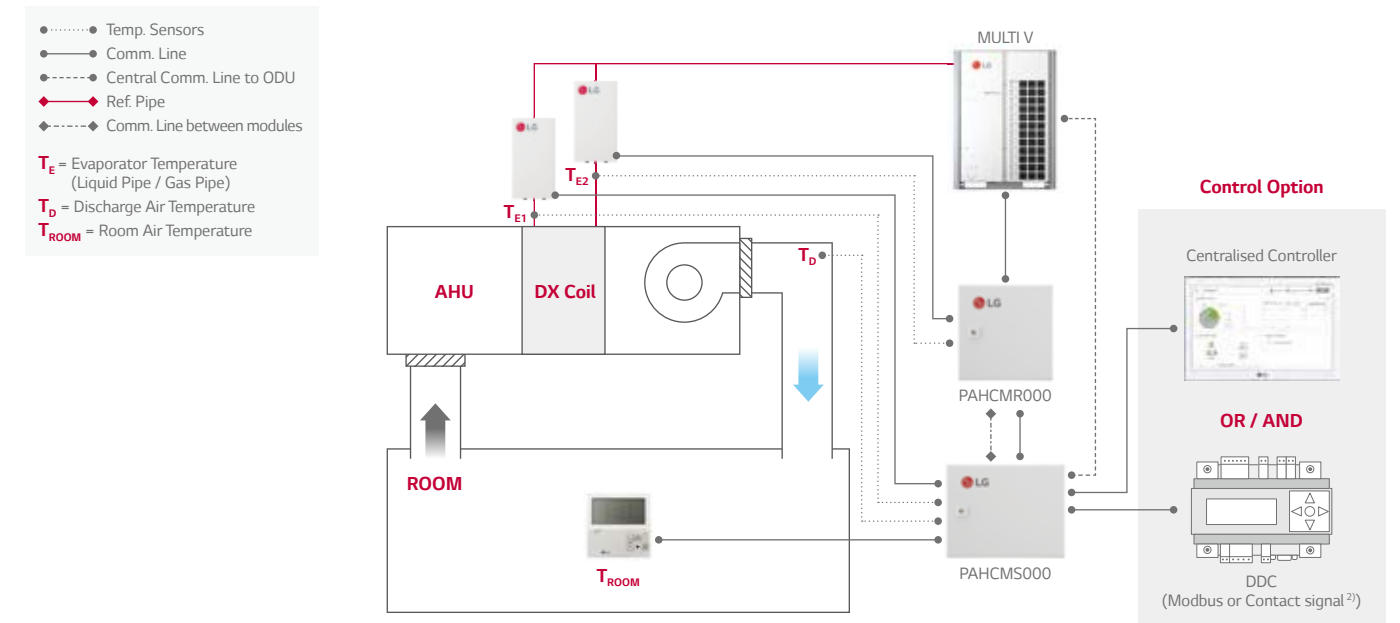

Note

1) PI485(PMNFP14A1) is required for centralised controller

2) In case of applying DDC with contact signal, discharge air temperature should be measured and controlled by DDC

3) For more detail, please refer to the PDB

Note

1) Multiple EEV kits can be applicable with multiple DX Coils and PAHCMR000s

2) In case of applying DDC with contact signal, discharge air temperature should be measured and controlled by DDC

3) For more detail, please refer to the PDB

# AHU KITS

## Communication Kit Application

### Large Capacity with MULTI V + TXV Kit + Return / Room Air Temperature Control

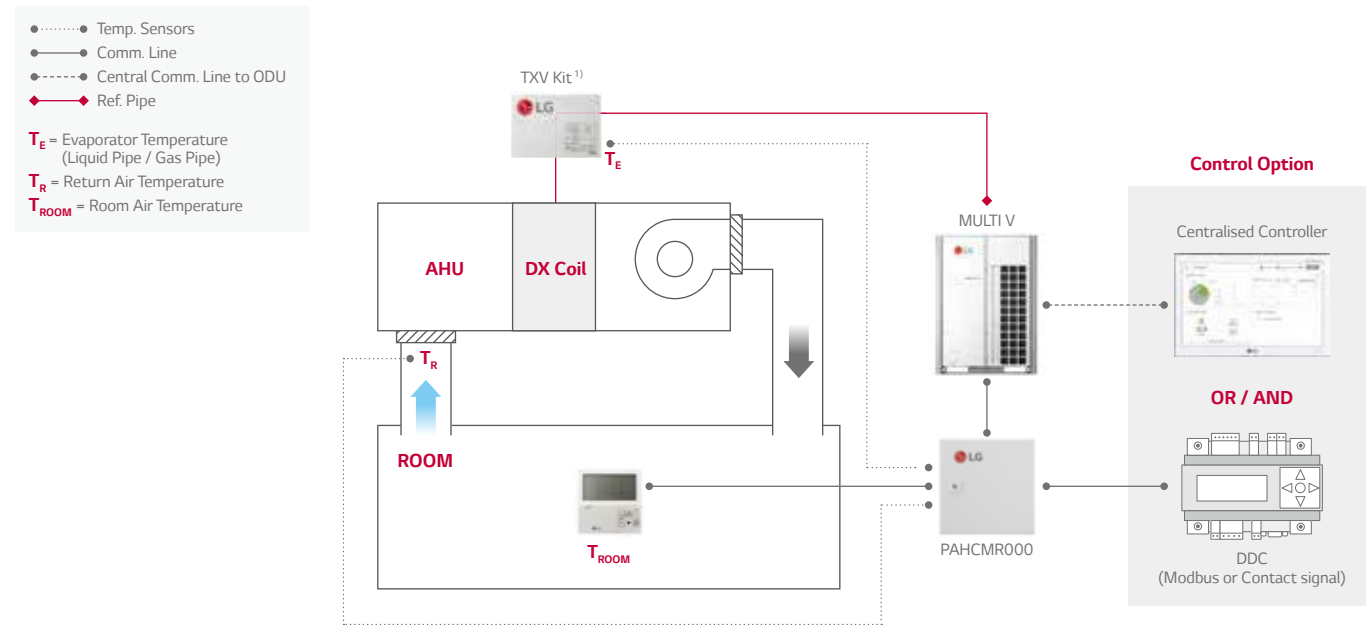

### Large Capacity with MULTI V + TXV Kit + Discharge Air Temperature Control

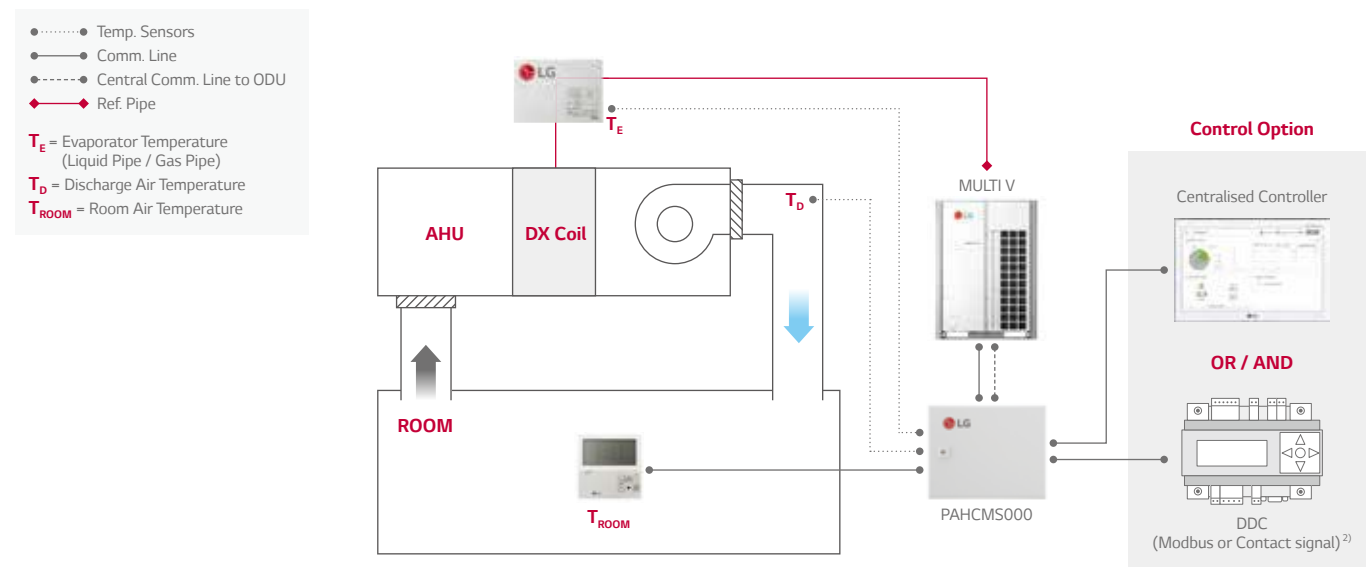

Note

- 1) TXV Kit should be connected with outdoor unit 1:1
- 2) In case of applying DDC with contact signal, discharge air temperature should be measured and controlled by DDC
- 3) For more detail, please refer to the PDB

## Communication Kit Function

### Communication with DDC via Contact Signal

Function List	PAHCMR000	PAHCMS000	Type	Electric Spec.
Control				
Comm. Kit Operation	On / Off		Digital Input	Non voltage
Operation Mode <sup>1)</sup>	Cooling / Heating		Digital Input	Non voltage
Return (room) Air Temperature <sup>2)</sup>	16-30°C	-	Analog Input	DC 0-10 V / 20 mA
Discharge Air Temperature <sup>3)</sup>	-	-		
Fan Speed <sup>4)</sup>	-	Low / Middle / High	Digital Input	Non voltage
Forced Thermal On / Off	On / Off	-	Digital Input	Non voltage
Capacity Control	-	•	Analog Input	DC 0-10 V / 20 mA
Monitor				
Comm. Kit Operation <sup>2)</sup>	On / Off		Digital Output	Max : DC 12 V / 1A, AC 250 V / 3A
Operation Mode	-			It needs to be checked through control signal
Return (room) Air Temperature	-			
Discharge Air Temperature	-			
Fan Speed <sup>2)</sup>	Low / Middle / High		Digital Output	Max : DC 12 V / 1A, AC 250 V / 3A
Defrost Operation <sup>2)</sup>	Defrost / Normal		Digital Output	Max : DC 12 V / 1A, AC 250 V / 3A
Error Alarm <sup>2)</sup>	Error / Normal		Digital Output	Relay C contact (Max : DC 30 V / 5A, AC 250 V / 5A)
Compressor On / Off	-	On / Off	Digital Output	Max : DC 12 V / 1A, AC 250 V / 3A

- 1) Available operation mode can be varied depending on the setting of Communication Kit
- 2) This function may not be possible depending on the setting of Communication Kit. For more details, please refer to the product data book
- 3) Discharge air temperature should be controlled directly through DDC
- 4) To control the fan speed using contact signal, DO ports for the status of fan speed needs to be connected with the fan unit

### Communication with DDC via Modbus protocol

Function List	PAHCMR000	PAHCMS000	Note
Control			
Comm. Kit Operation	On / Off		
Operation Mode <sup>1)</sup>	Cooling / Heating		
Return (room) Air Temperature	16-30°C	-	
Discharge Air Temperature	-	16-30°C	
Fan Speed <sup>2)</sup>	Low / Middle / High	-	
Forced Thermal On / Off	-		
Capacity Control	-	•	
Monitor			
Comm. Kit Operation	On / Off		
Operation Mode <sup>1)</sup>	Cooling / Heating		
Return (room) Air Temperature	-50-100°C	-	Corresponding air temperature sensor connected to AHU comm. kit is required
Discharge Air Temperature	-	-50-100°C	
Fan Speed	Low / Middle / High	-	
Defrost Operation	On / Off		
Error Alarm	Error Alarm & Code		
Compressor On / Off	On / Off		

- 1) Available operation mode can be varied depending on the setting of Communication Kit
  - 2) To control the fan speed using Modbus, DO ports for the status of fan speed needs to be connected with the fan unit
- \* For the Modbus memory map, please refer to the product data book



# AHU KITS

## Communication Kit Function

With LG Control system (Individual & Centralised Controller)

- 1) Available operation mode can be varied depending on the setting of Communication Kit. For more details, please refer to the product data book
  - 2) This range may differ depending on the type of controller
  - 3) To control the fan speed using contact signal, DO ports for the status of fan speed needs to be connected with the fan unit
- \* Control function is unavailable in case of using together with DDC via contact signal

## Compatibility with LG HVAC Controllers

Controller	Individual Controller							BMS Gateway	PDI
	Premium	Standard III	Standard II	AC Ez Touch	AC Smart	ACP	AC Manager <sup>1)</sup>	ACP Lonworks	Premium Standard
Model no.	PREMTA000	PREMTB100	PREMTB001	PACEZA000	PACSSA000	PACP5A000	PACMSA000	PLNWKB000	PQNUD1S40 PPWRDB000
PAHCMR000	•	•	•	•	•	•	•	•	•
PAHCMS000	X	X	• <sup>2)</sup>	X	•	•	•	X	X

- 1) AC Manager is an integrator, so the installation with AC Smart or ACP is required
- 2) Set temperature range of this model shall be extended in the future
- \* Dry contact for indoor unit(PDRYCB000/400/300/500) is not applied
- \* For more details, please refer to the product data book

## Communication Kit Function

Outdoor Unit Compatibility

Multi V

Model		MULTI V				MULTI V WATER			
		S	IV	III	S	IV	II	S	
AHU Controller	PAHCMR000	•	•	•	•	•	•	•	
	PAHCMS000	•	•	•	•	•	•	X	

Single Split

		Standard Inverter (1-phase)							
Capacity	Cooling	kW	4.7	7.7	8.0	10.0	12.5	13.9	14.6
	Heating	kW	5.5	8.0	9.0	11.0	14.0	15.4	16.9
AHU Kit	PAHCMR000		•	•	•	•	•	•	•
	PAHCMS000		•	•	•	-	-	-	-

		Standard Inverter (3-phase)							
Capacity	Cooling	kW	10.0	12.5	13.9	14.6	19.0	23.0	
	Heating	kW	11.0	14.0	15.4	16.9	22.4	27.0	
AHU Kit	PAHCMR000		•	•	•	•	•	•	
	PAHCMS000		-	-	-	-	•	•	

\* Table of the outdoor unit compatibility is based on European regional model.  
When connecting outdoor units in other areas, please check whether they are compatible or not.

## Expansion valves for MULTI V system

EEV Kit	PRLK048A0											PRLK096A0				
	Cooling (kW)	3.6	4.5	5.6	7.1	8.2	10.6	12.3	14.1	15.8	22.4	28	33.6	39.2	44.8	50.4
Heating (kW)	4	5	6.3	8	9.2	11.9	13.8	15.9	18	25.2	31.5	37.8	44.1	50.4	56.7	63

TXV Kit	PATX13A0E				PATX20A0E				PATX25A0E				PATX35A0E				PATX50A0E			
	Cooling (kW)	22.4 - 44.8				50.4 - 72.8				78.4 - 100.8				106.4 - 128.8				134.4 - 156.8		
Heating (kW)	25.2 - 50.4				56.7 - 81.9				88.2 - 112.1				118.4 - 143.6				148.5 - 175.1			

- \* Capacities are based on the following conditions :  
 - Cooling : Indoor 27°C(80.6°F) DB / 19°C(66.2°F) WB Outdoor 35°C(95°F) DB / 24°C(75.2°F) WB  
 Condensing temperature (tc) 46°C, Subcool (SC) 3 K, Evaporating temperature (te) 6°C, Superheat (SH) 5 K  
 - Heating : Indoor 20°C(68°F) DB / 15°C(59°F) WB Outdoor 7°C(44.6°F) DB / 6°C(42.8°F) WB  
 Hot gas inlet temperature 70°C, Condensing temperature (tc) 46°C, Subcool (SC) 3 K  
 - Piping Length : Interconnected Pipe Length = 7.5m  
 - Difference Limit of Elevation (Outdoor - Indoor Unit) is zero

# AHU KITS

## Control Kit

List	Required Item
Heating / Cooling	SA / RA temperature sensor (or SA / RA temperature & humidity sensor)
Automatic Ventilation	SA / RA temperature, CO <sub>2</sub> sensor; Damper actuator (OA, EA, MA)
Energy Saving (Cooling Mode Only)	SA temperature, OA / RA temp&humidity sensor, Damper actuator (OA, EA, MA)
Humidification	SA temperature, RA temperature & humidity sensor, Humidifier
Inverter Fan Control	SA / RA temperature, Static pressure sensor, Inverter driver for fan control
Filter Alarm	Difference pressure sensor
Smoke Detecting	Smoke detection sensor

RA : Return Air, EA : Exhaust Air, OA : Outdoor Air, SA : Supply Air, MA : Mix air (RA + OA)

## Field Supplied Item

List	Required Specification	Apply Location
Temperature Sensor	- Power : AC 24V, Output signal : DC 0 ~ 10V - Temperature boundary : -50 ~ 50°C	- Apply to MA, SA, RA
Temperature & Humidity Sensor	- Power : AC 24V, Output signal : DC 0 ~ 10V - Temperature boundary : -40 ~ 70°C - Humidity boundary : 0 ~ 95% RH	- Apply to SA, RA, OA - Can not be applied to MA
Damper Actuator	- Power : AC 24V, In/Output signal : DC 0 ~ 10V - Torque : 15 Nm, Operation time : 150sec. - Rotation angle : 90°	- Apply to OA, EA, MA damper
Difference Pressure Sensor (for Filter)	- Power : AC 24V, Output signal : DC 0 ~ 10V * Boundary : 0 ~ 1000Pa - Switch type : Relay Open / Close	- Apply to filter
Static Pressure Sensor	- Power : AC 24V, Output signal : DC 0 ~ 10V - Boundary : 0 ~ 1000pa	- Apply to SA (for inverter control)
CO <sub>2</sub> Sensor	- Power : AC 24V, Output signal : DC 0 ~ 10V - Boundary : 0 ~ 2000ppm	- Apply to RA duct
Smoke Detection Sensor	- Power : AC 24V, From : Contact point type	- Apply to RA duct

Note : Boundary of specification can be changed through LGAV software. However, please make a specification referring to the above table

## Various Control with Control kit – Multiple MULTI Vs + TXV Kits

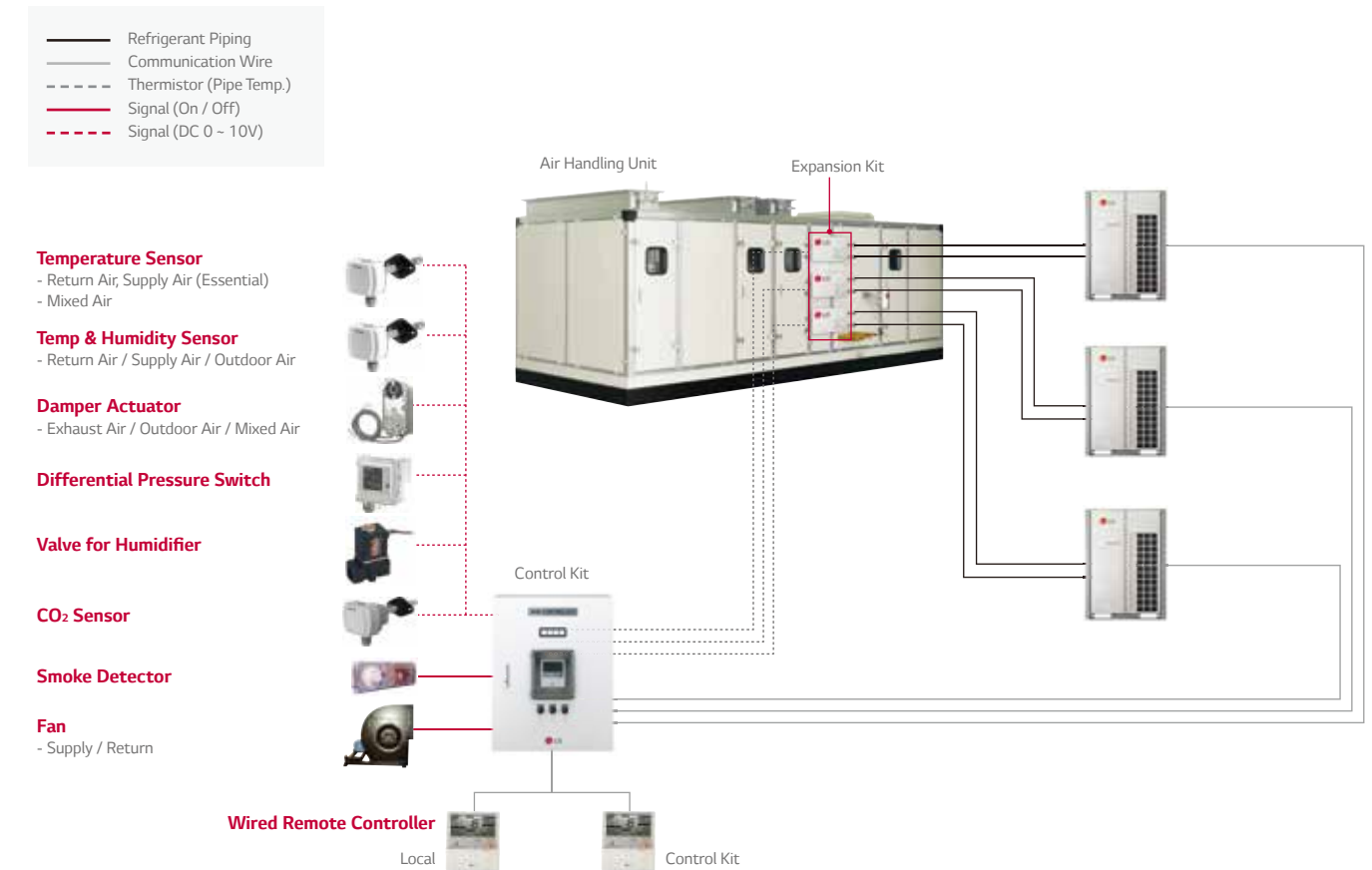

# ACCESSORIES





# CASSETTE PANEL

Stylish designed panels make more unique space by various applications

**4 Way Cassette**  
PT-UQC / PT-UMC1

**2 Way Cassette**  
PT-USC

**1 Way Cassette (Grill Type)**  
PT-UUC



## Features

- Independent vane operation uses separate motors, making it Possible to control all four vanes independently.
- The detachable corner design makes it easy to adjust the hanger during installation and to check for leakages in the drain connection pipe.

## Compact and Stylish Design

- New 4 way cassette panel adapted unibody shape and matching with into the ceiling
- Panel size is fit into the ceiling tile

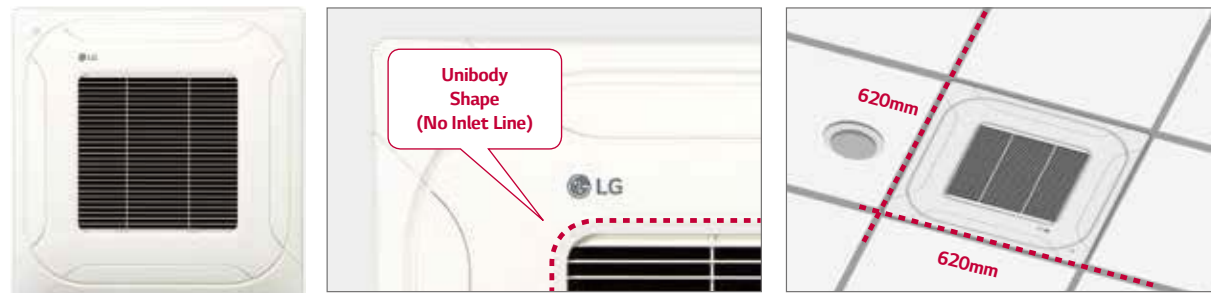

## Specifications

Model name	Suction Type	Color (RAL)	Gloss	Weight (kg)	Dimension (mm)			Applied model			
					W	H	D	SINGLE SPLIT	MULTI SPLIT	MULTI V	
4 Way	PT-UQC	Horizontal Grill	Morning Fog (RAL 120-4)	X	3.0	700	22	700	2.5 - 5.0kw	1.5 - 5.0kw	1.5 - 5.0kw
	PT-UMC1	Horizontal Grill	Morning Fog (RAL 120-4)	X	5.6	950	25	950	7.1 - 15.0kw	7.1kw	7.1 - 14.0kw
2 Way	PT-USC	Grill	Morning Fog (RAL 120-4)	X	4.7	1,100	33	690	-	-	5.0 - 7.1kw
1 Way	PT-UUC	Grill	Noble White (RAL 110-1)	O	4.6	1,100	34	500	-	-	2.1 - 3.5kw

# DRAIN PUMP KIT

Drains away condensed water

**ABDPG**  
**PBDP9**



## Features

- In some places where natural drainage is not possible, a drain pump is very useful to pump out condensed water from indoor units.
- Drain pump assembly (AC 220 ~ 240V, 50 / 60Hz)

## Models Applied

- Ceiling Concealed Duct (Refer to PDB for applicable models)

## Accessory Model Name

Ceiling Concealed Duct (Refer to PDB for applicable models)

Product	Model	Drain Pump	
SINGLE / MULTI SPLIT	H-INVERTER	Included	
	Standard Inverter	CB**L	Included
		CM** / UM**	ABDPG
		UB70 / UB85	PBDP9
Compact Inverter	ABDPG		
MULTI V		Included	

## Application

High head drain pump automatically drains water up to 700mm of drain-head height. It provides perfect solution for water drainage.

### High Head Drain Pump



\* Included in H-Inverter  
\* Supplied as accessory for Standard Inverter (ABDPG/ PBDP9)

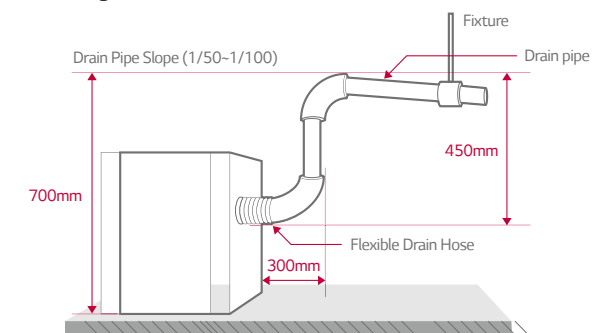

# REFRIGERANT LEAKAGE DETECTOR

R410A refrigerant leakage detector makes our space safer



## PRLDNVSO



### Features

- This detector senses refrigerant leakage and when the refrigerant concentration exceeds 6,000ppm not only it will stop indoor unit operation, but also it will give an alarm using buzzer and sensor LED. (The green and red LED lights blink simultaneously.)
- Alarm is "ON" over 6,000ppm has been maintained 5 seconds, and on the contrary to this, Alarm is "OFF" under 6,000ppm has been maintained 5 seconds.
- When the alarm of the refrigerant leak detector is switched on the user must ventilate until the alarm is disabled.
- The detector has to be installed inside the room and it can be installed 300 ~ 500mm from floor.

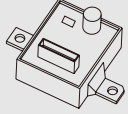
### Specifications

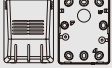
Parts	Specifications	
Sensor 	Rated Voltage (V)	DC 5.0 ± 5%
	Dimensions (W x H x D, mm)	31 x 44 x 20
	Weight (g)	22
	Detectable Refrigerant	R410A
	Detected Concentration (ppm)	0 / 6,000 Alarm Off / On
	Operating Temperature Range (°C)	-10 ~ 50
	Preserved Temperature Range (°C)	-40 ~ 60
	Average Power Consumption (mA)	35
Connecting Cable 	Cable Length (m)	10
Sensor Protective Cover 	Dimensions of Front Plate (W x H x D, mm)	80 x 110 x 44.6
	Dimension of Backplate (W x H x D, mm)	80 x 110 x 6.5

### Application

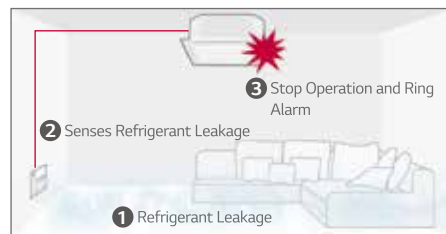

# EEV KIT

MULTI V EEV KIT is specially designed to reduce noise and make comfort environment

## PRGK024A0



### Features

- Decreasing noise level of Multi V Indoor units Easy installation

### Models Applied

- Ceiling Cassette (up to 4.5kW)
- Wall mounted (up to 7.1kW)
- Floor Standing Unit (with case / without case) (up to 4.5kW)
- Convertible (up to 3.6kW, Ceiling Suspended Type is not able to connect this Kit)
- Ceiling concealed duct (up to 5.6kW)
- Console (up to 4.5kW)

\* Fresh Air intake Unit is not able to connect this Kit

### Application

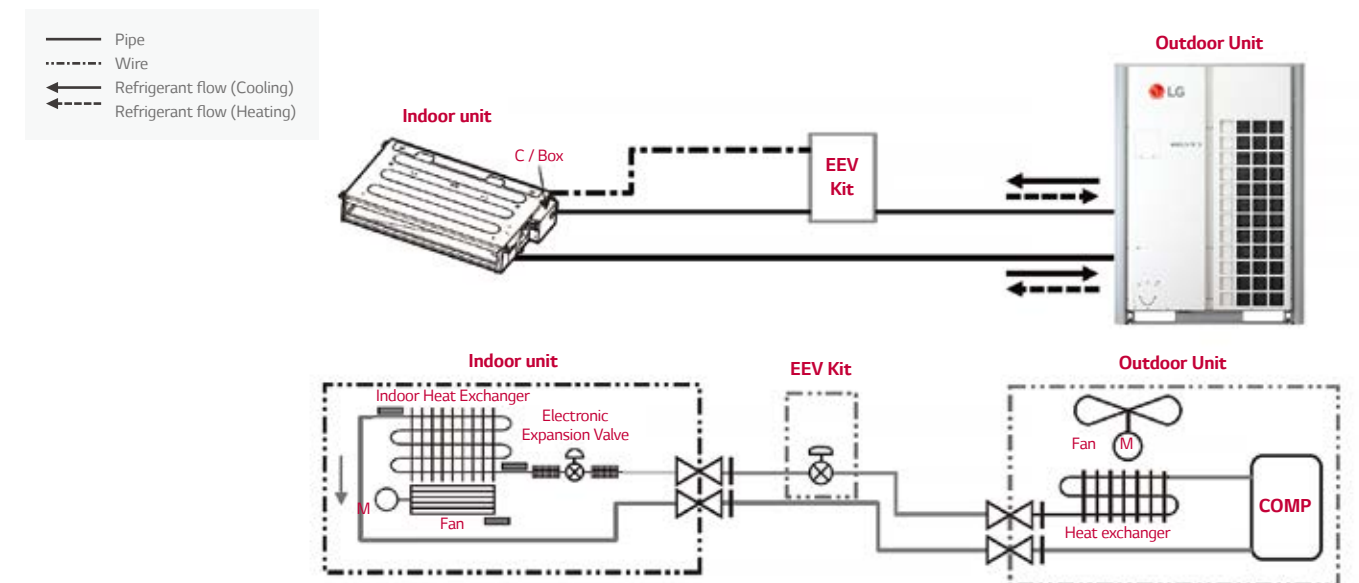

Note : If you don't use EEV of same specification, Cooling (Heating) capacity may decrease.

# INDEPENDENT POWER MODULE

EEV full close function in case of power cut

## PRIPO



## Features

Independent Power Module is specially designed to close the Indoor EEV at power cut-Off.

- Supply Voltage : DC 12V ± 50%

## Models Applied

- MULTI V Indoors

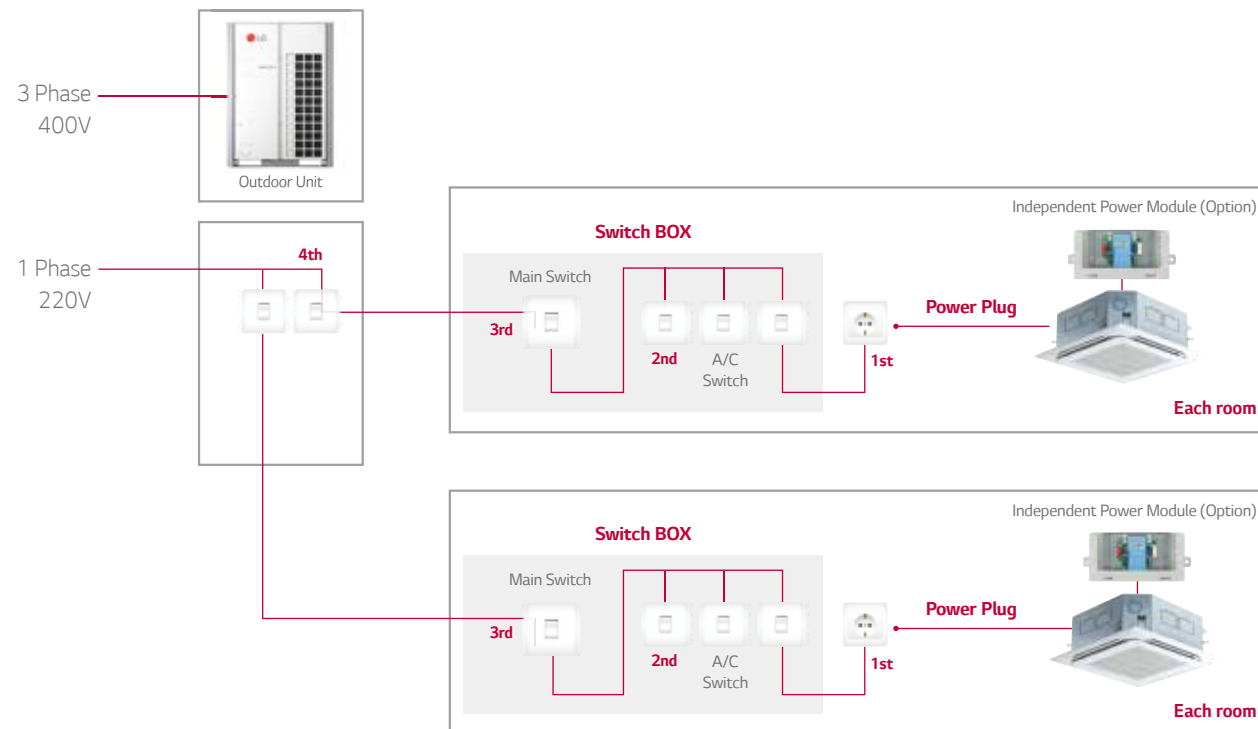

# LINE-UP

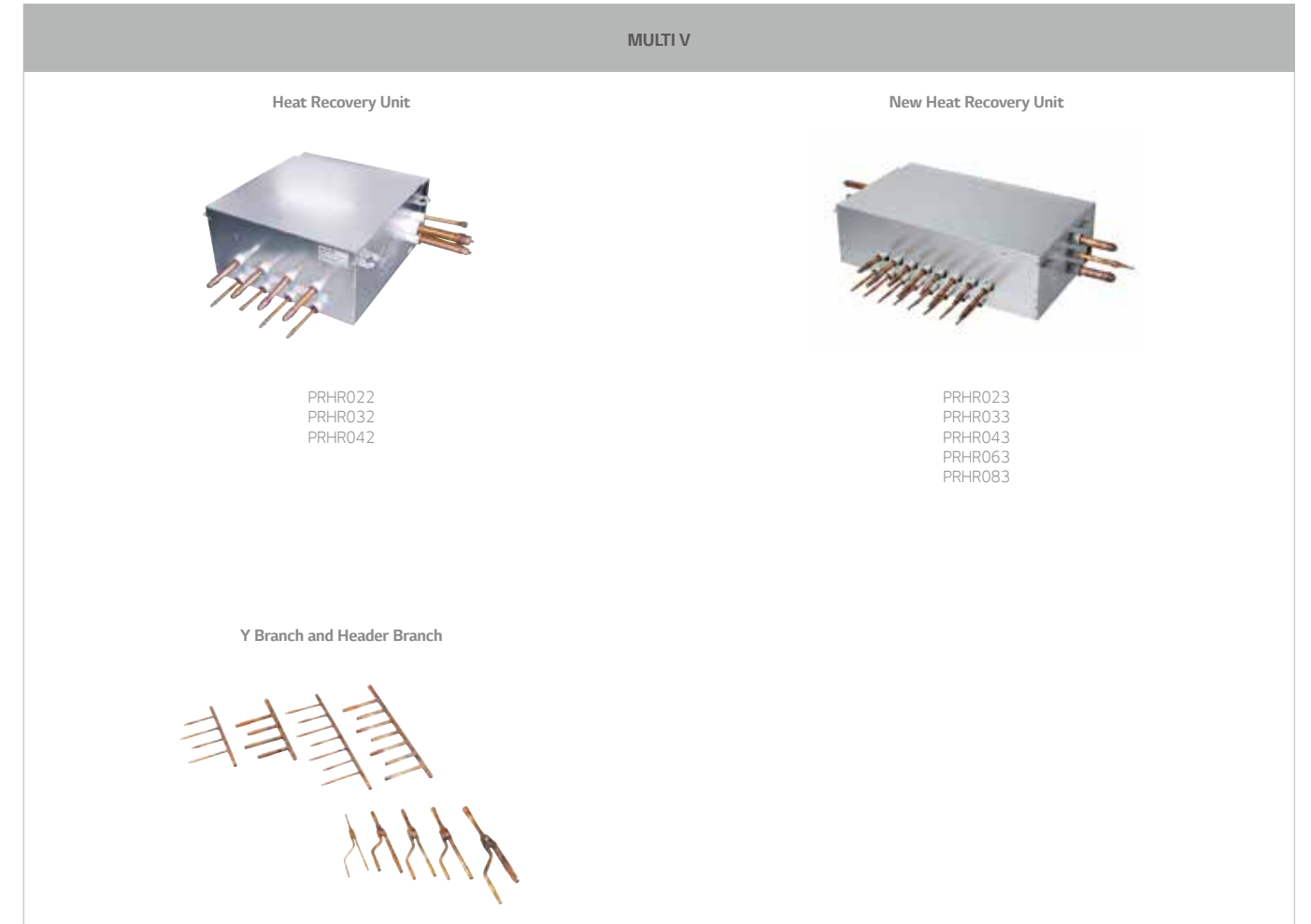

## Mechanical Accessories Line up and Application

Model name	SINGLE SPLIT	MULTI	MULTI V	Remark
Y Branch and Header Branch (Synchro)	•	-	-	-
Branch Distributor (MULTI)	-	•	-	MULTI F DX systems
Y Branch and Branch Kit (MULTI)	-	•	-	MULTI F DX systems
New Heat Recovery Unit (Multi V)	-	-	•	MULTI V 5
Heat Recovery Unit (Multi V)	-	-	•	MULTI V 5 / MULTI V IV HR / MULTI V III HR MULTI V S HR / MULTI V SYNC II / MULTI V SYNC MULTI V WATER IV HR / MULTI V WATER II HR
Y Branch and Header Branch (MULTI V)	-	-	•	Various type of MULTI V Series



# NEW HEAT RECOVERY UNIT

- PRHR023 (2 Branch Unit)
- PRHR033 (3 Branch Unit)
- PRHR043 (4 Branch Unit)
- PRHR063 (6 Branch Unit)
- PRHR083 (8 Branch Unit)

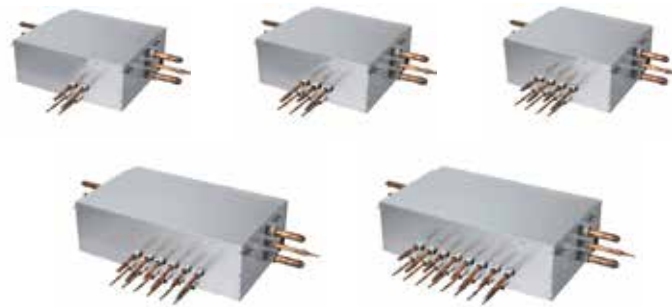

## Features

- Max. 64 indoor units can be connected (Max. 8 indoor units per branch)
- It is easy to install due to the automatic search algorithm for piping detection
- Subcooling cycle in HR unit makes the system efficiency maximum

## Models Applied

- MULTI V 5 Heat Recovery

## Specifications

Model name			PRHR023	PRHR033	PRHR043	PRHR063	PRHR083	
Number of Branch		EA	2	3	4	6	8	
Maximum Connectable Capacity of Indoor Units (Per branch / unit)		kW	17.5/35	17.5/52.5	17.5/69.5	17.5/69.5	17.5/69.5	
Maximum Number of Connectable Indoor units per Branch		EA	8	8	8	8	8	
Nominal Input	Cooling	kW	0.040	0.040	0.040	0.076	0.076	
	Heating	kW	0.038	0.038	0.038	0.072	0.072	
Net. Weight		kg	18.5	20.3	22.0	28.3	31.8	
Dimensions (W x H x D)		mm	786 x 218 x 657	786 x 218 x 657	786 x 218 x 657	1,113 x 218 x 657	1,113 x 218 x 657	
Piping connections	Indoor Unit	Liquid	mm (inch)	9.52 (3/8)	9.52 (3/8)	9.52 (3/8)	9.52 (3/8)	9.52 (3/8)
		Gas	mm (inch)	15.88 (5/8)	15.88 (5/8)	15.88 (5/8)	15.88 (5/8)	15.88 (5/8)
	Outdoor Unit	Liquid	mm (inch)	9.52 (3/8)	12.7 (1/2)	15.88 (5/8)	15.88 (5/8)	15.88 (5/8)
		Low pressure	mm (inch)	22.2 (7/8)	28.58 (11/8)	28.58 (11/8)	28.58 (11/8)	28.58 (11/8)
		High Pressure	mm (inch)	19.05 (3/4)	22.2 (7/8)	22.2 (7/8)	22.2 (7/8)	22.2 (7/8)
Power supply		Ø / V / Hz	1 / 220-240 / 50 1 / 220 / 60	1 / 220-240 / 50 1 / 220 / 60	1 / 220-240 / 50 1 / 220 / 60	1 / 220-240 / 50 1 / 220 / 60	1 / 220-240 / 50 1 / 220 / 60	

## Parts Included

- HR unit (1EA)
- Washers M10 (8EA)
- Hanging bolts M10 or M8 (4EA)
- Reducers
- Nut M8 or M10 (8EA)

## Reducers for Indoor Unit and HR Unit

(Unit : mm)

Model Name	Liquid	High pressure	Low pressure
Indoor Unit Reducer			
HR Unit Reducer	PRHR023 		
HR Unit Reducer	PRHR033 PRHR043 PRHR063 PRHR083 		

## Convenient Free Zoning

MULTI V Heat Recovery provides flexible control over individual zones for the user's convenience

- **Individual Control**
  - Perfect individual control over spaces ventilation needed
- **Zone Control**
  - Max. of 8 indoor units can be connected for one branch
  - Max. of 64 indoor units can be connected for one HR unit
  - Same operational model can be operated by indoor units with zone control function installed
- **Combination of Individual and Zoning Installations**
  - Flexible piping design
- **Save Product and Installation Cost**

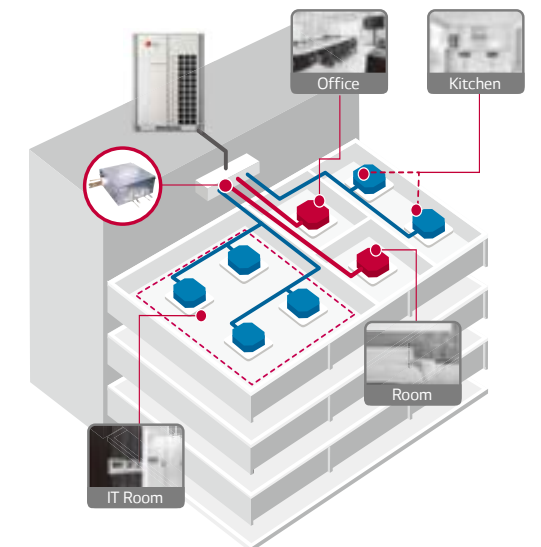

[Zoning Control]

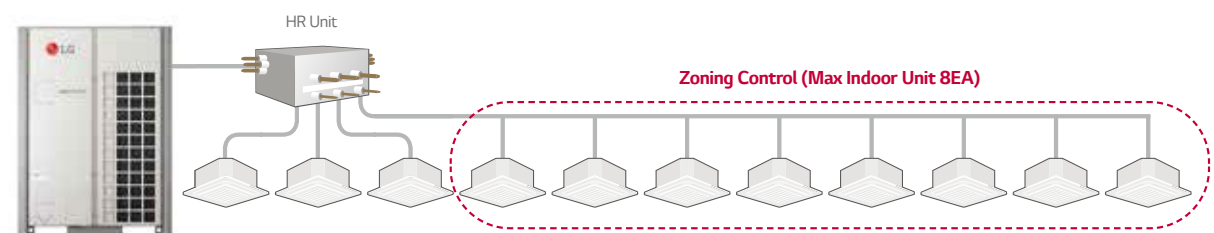

# NEW HEAT RECOVERY UNIT

## Improving Service Workability

Can inspect valves and PCBs under the product.(looking up at the product)

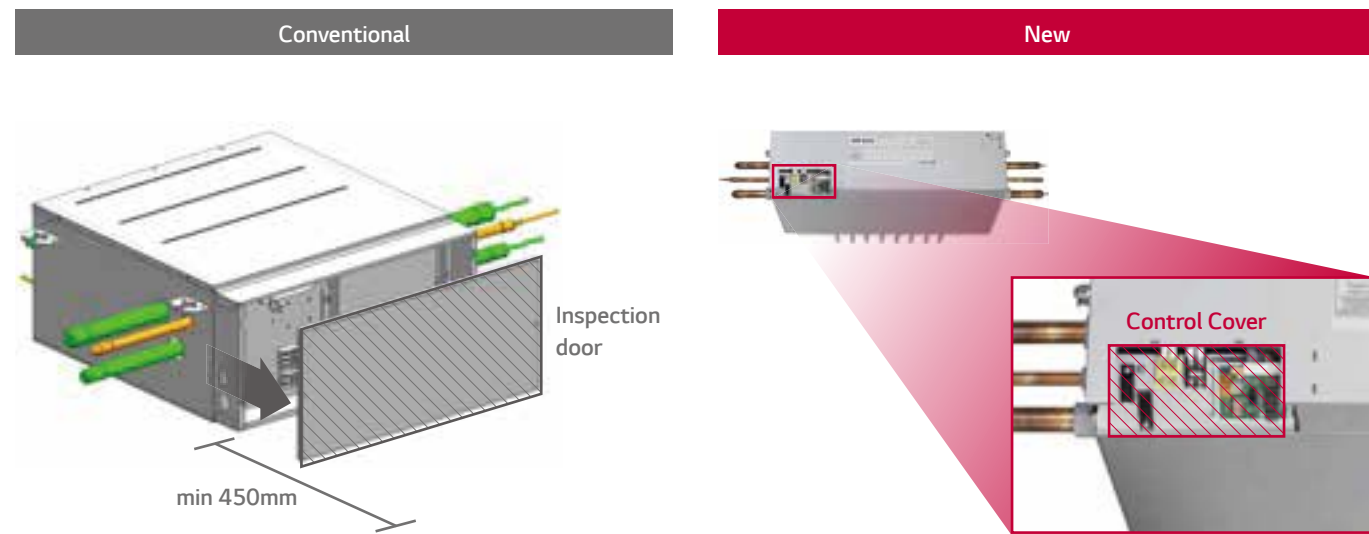

At least 450 mm of space is required to open the control cover and to inspect or repair the product.

The control cover can be opened(disassembled) in the downward direction. → Error code check and simple check & repair are possible.

## Expansion of connection capacity

- Expansion of connection capacity per port : (old) 15kW → (new) 17kW
- Expansion of total connectable capacity : (old) 60kW → (new) 71.87kW

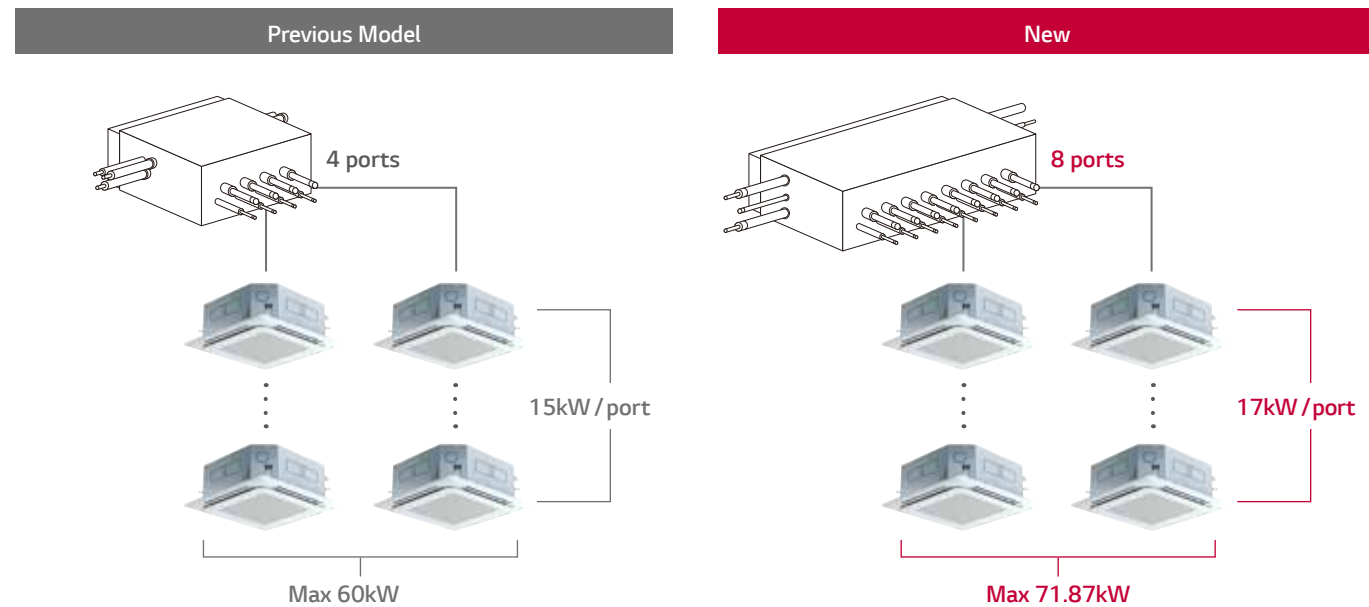

## Easy Series Connection

Series connection can be installed without pipes crossing.

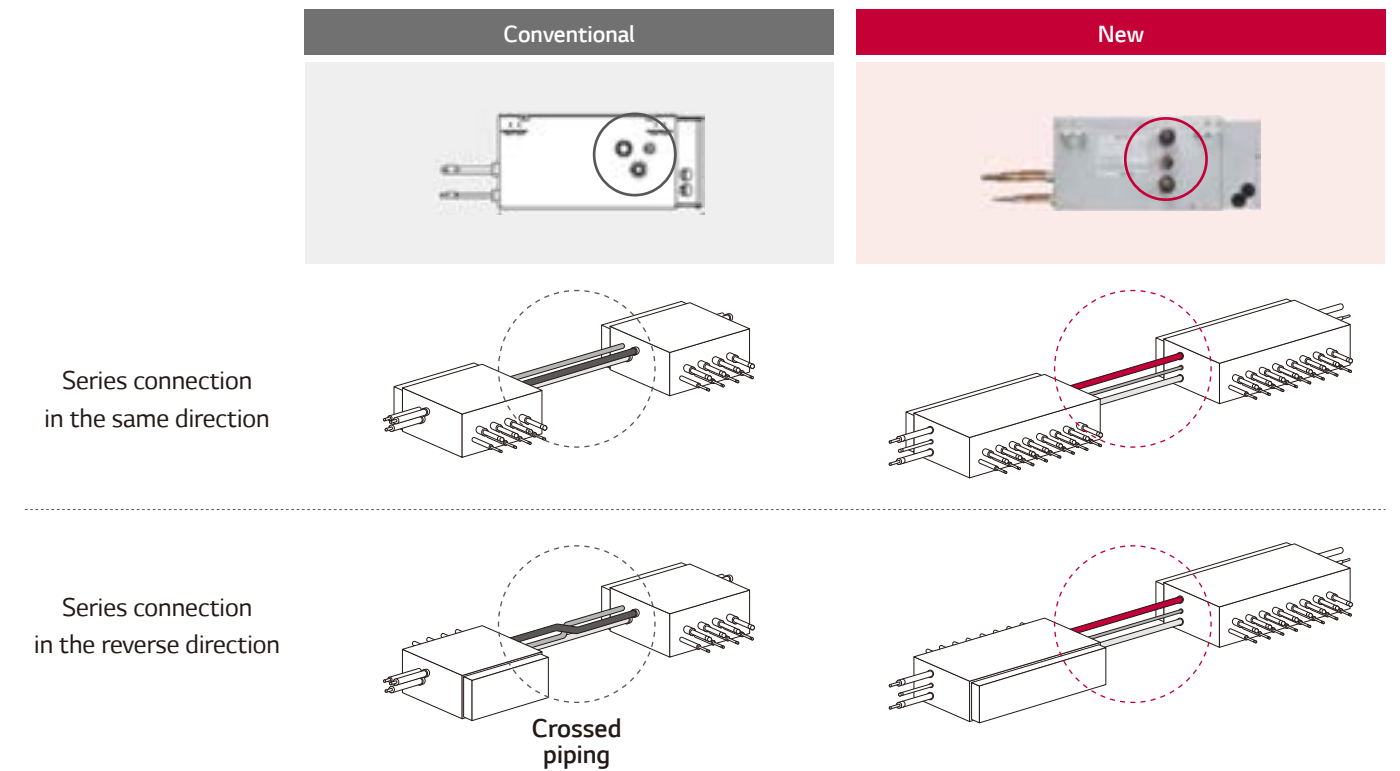

## Reduce Noise

Cooling ↔ Heating changeover noise improvement

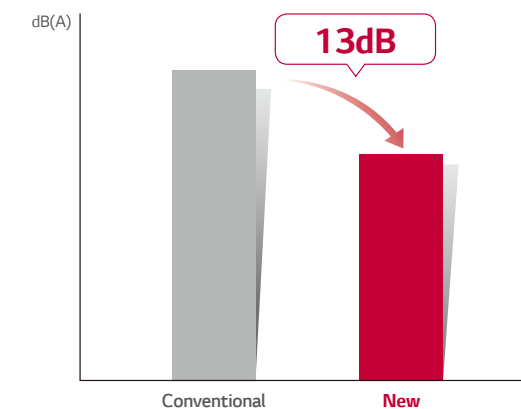

# Y BRANCH AND HEADERBRANCH



For refrigerant distribution of indoor units

## Y Branch Header Branch



### Features

- Various Y Branch pipe of different capacities make MULTI V installation much easier.
- Y Branch and header branch for both gas and liquid are provided.
- Insulation material is also provided for covering the branches.

### Piping Diagram

#### Heat Pump System

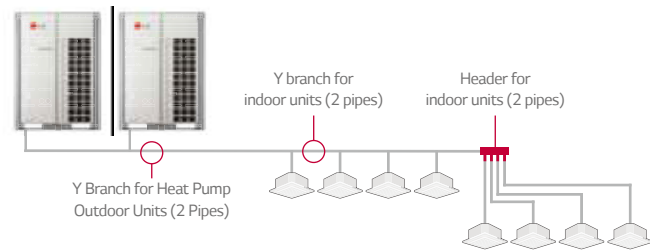

#### Heat Recovery system

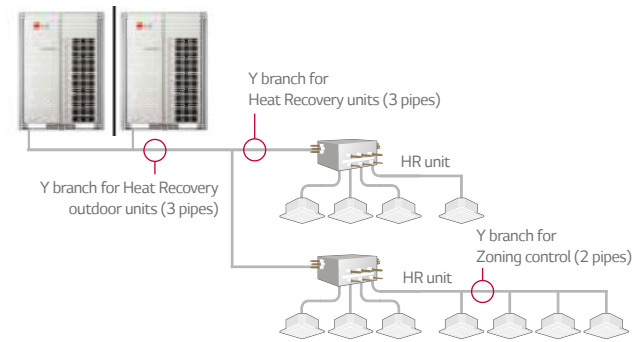

### Models Applied

- MULTI V 5
- MULTI V IV
- MULTI V III, MULTI V PLUS II, MULTI V PLUS
- MULTI V S
- MULTI V WATER IV
- MULTI V WATER II
- MULTI V WATER S
- MULTI V SPACE II
- MULTI V MINI

### Details of Model Name

#### Header Branch

R410A

(Unit : mm)

Model Name	Gas Pipe	Liquid Pipe
4 Branch / ARBL054		
7 Branch / ARBL057		
4 Branch / ARBL104		
7 Branch / ARBL107		
10 Branch / ARBL1010		
10 Branch / ARBL2010		



# PIPING ACCESSORIES

## Y Branch pipe for connection of outdoor units

### Heat Pump

**R410A** MULTI V 5, MULTI V IV, MULTI V III, MULTI V WATER IV, MULTI V WATER II

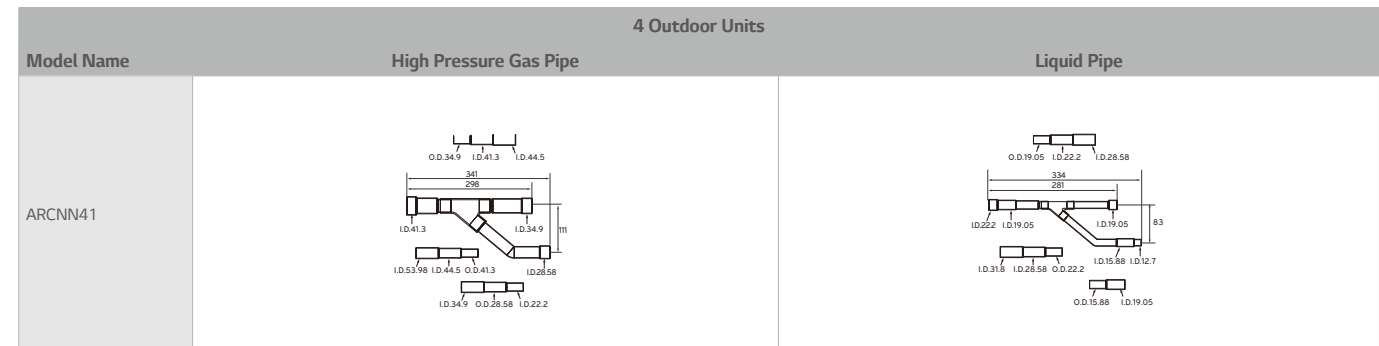
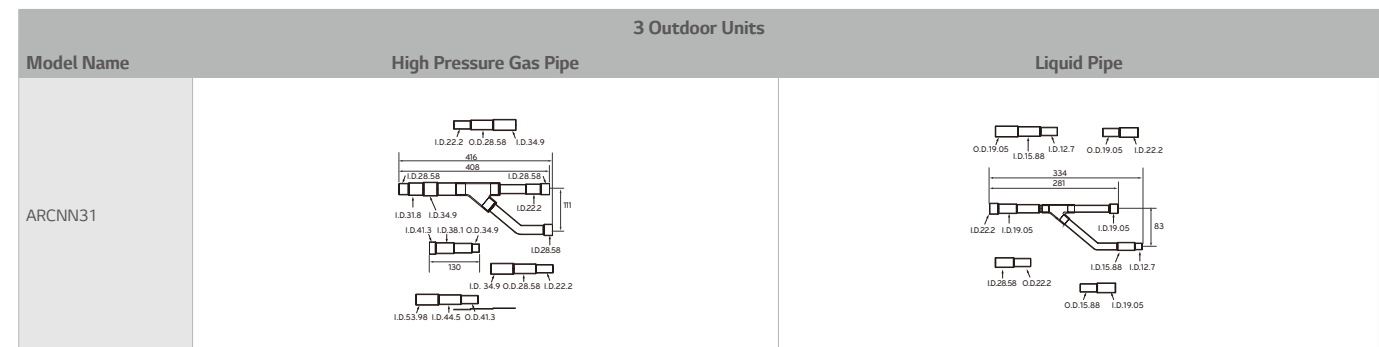
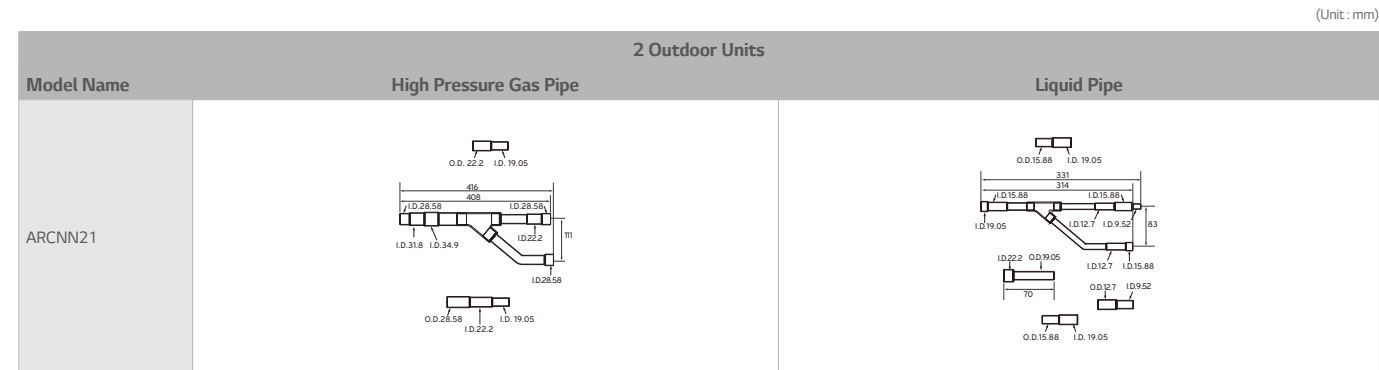

### Heat Recovery

**R410A** MULTI V 5, MULTI V IV Heat Recovery, MULTI V III Heat Recovery, MULTI V WATER IV Heat Recovery, MULTI V WATER II Heat Recovery

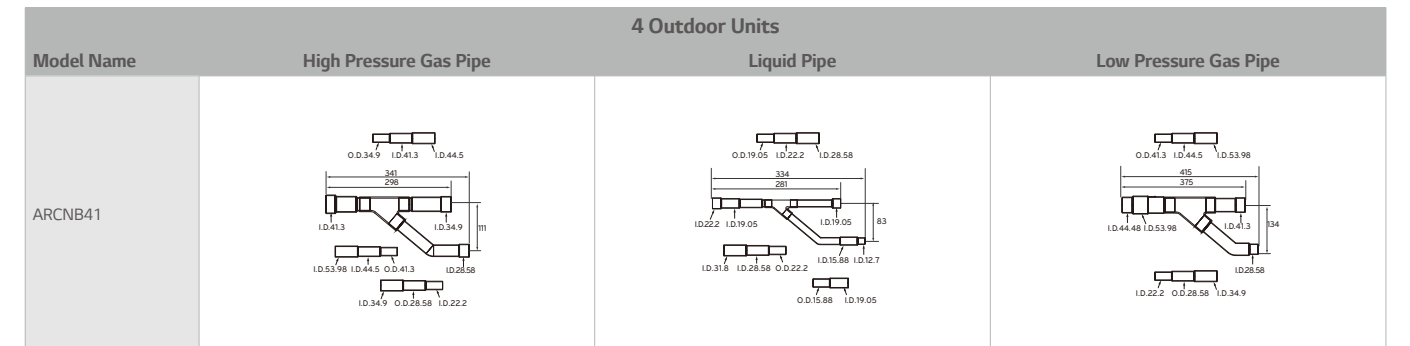
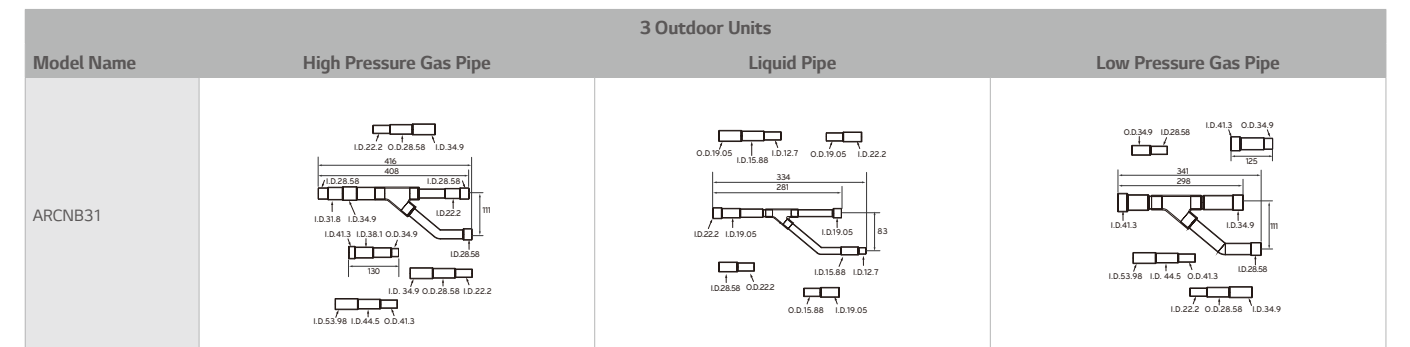
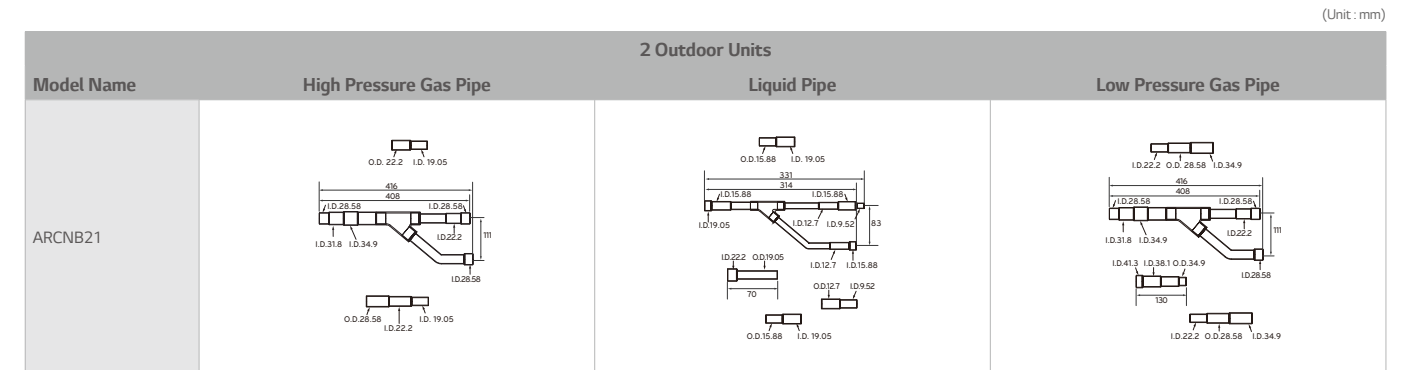





Find out more

[lg.com/au/commercial-air-conditioning](http://lg.com/au/commercial-air-conditioning)

October 2020