



Published by

### **Assistive Technology Services**

*“Our mission is to provide evaluation, consultation, spiritual guidance and assistive devices to make the quality of life better for those that need a little help.”*

Nashville, TN: 615-562-0043  
Cookeville, TN: 931-303-5308  
Murfreesboro, TN: 615-308-9165

To see *MANY* more assistive products,  
Visit our website:  
[www.ATS-TN.com](http://www.ATS-TN.com)

email: [questions@ATS-TN.com](mailto:questions@ATS-TN.com)



**PAVDII  
QUICK START GUIDE  
and MANUAL**

### **PERSONAL ASSISTANCE VOICE DIALER II**





## PAVDII QUICK START GUIDE

### INSTALLATION

**IMPORTANT: Telephone line needs to be disconnected prior to opening the battery compartment**

- Unscrew battery compartment at bottom of unit
- Insert 4 Alkaline AA (LR06, 1.5V) batteries (not included)
- Close battery compartment
- Connect one end of phone line cord to telephone line wall jack and other end to back side of telephone
- Connect power adapter to connection at back panel and to available power socket

### STORING EMERGENCY CONTACT NUMBERS

- Set **MENU** switch at back of phone to “**ON**”
- Press **PRO**
- Press **▲** 2 x to select “**STORE NUMBER**”
- Press **OK/C** to enter
- Enter telephone number to be stored
- Press **DEL** to delete a wrong entered number
- Use **▲** and **▼** to move back and forward through number
- Press **OK/C** to confirm
- Enter name using characters on numeric keypad
- Press **DEL** to delete a wrong entered character
- Use **▲** and **▼** to move back and forward through characters
- Press **OK/C** to confirm
- Select “**EMERGENCY OFF**” or “**EMERGENCY ON**”

### SERVICE

According to FCC regulation, this equipment which has been certified and registered by the FCC, may only be repaired by authorized person, the FCC certification may be voided.

Should you encounter any problems or need service, please call **ASSISTIVE TECHNOLOGY SERVICES LLC** Customer Service Hotline for assistance: **615-562-0043** Monday - Friday 8:00 am - 5:00 pm CST. (If unit is under Warranty, **PROOF OF PURCHASE MUST BE PROVIDED**).

For general inquires, e-mail [orders@ats-tn.com](mailto:orders@ats-tn.com) or visit website at [www.ats-tn.com](http://www.ats-tn.com).

### LIMITED WARRANTY AND SERVICE

**ASSISTIVE TECHNOLOGY SERVICES** warrants this product to be free from defective materials or factory workmanship and will replace or repair this unit or any part thereof, except batteries, if it proves to be defective in normal use or service within one year from date of original purchase. Our obligation under this warranty is the repair or replacement of the defective instrument or any part thereof, except batteries. Customer is responsible for all shipping costs of defective unit. This warranty will be considered void if unit is tampered with, improperly serviced or subjected to misuse, negligence or accidental damage. There are no other express warranties other than those stated herein. This warranty gives you specific legal rights and you may also have other rights which vary from state to state.

It is important that the receiving party of an emergency call presses '0' to accept the call. If the emergency call is not accepted, the telephone will call the next number from the emergency number list.

NOTE: The system will continue to call the emergency contact numbers, in sequence, over and over until someone accepts the call or the call is terminated by the user.

After 1 minute 50 seconds, a beep tone will indicate the emergency call will be terminated. The receiving party should press 1+5 to add an extra 2 minutes to the call.

Once the receiving party has pressed 1+5 during the emergency call (or after 1 minutes 50 seconds to extend the call for another 2 minutes), SOS function will be deactivated.

Once the receiving party has pressed 1+9 during the emergency call, the emergency call will be terminated.

If the receiving party did not press 1+5 during the emergency call after 1 minute 50 seconds, the SOS function will not be deactivated and telephone will call the next number from the emergency number list.

Each time a number is called, the system will **dial for 1 minute**. If the system does not hear a receiver press '0' within 1 minute, it will hang up and dial the next number.

NOTE: Calling can be stopped by pressing the Pendant button again or the SOS button located on the phone

In case of "**EMERGENCY ON**" you need to select the position of this number (specifies in what order it will be dialed)

- Use ▲ or ▼ to select the position
- Press **OK/C** to confirm

In case you want to overwrite an existing position, you will have to confirm "**OVERWRITE?**" by pressing **OK/C**.

### **STORING EMERGENCY MESSAGE**

- Press **PRO**
- Press ▲ 4 x to select "**RECORD MESSAGE**"
- Press and **hold OK/C**, wait for beep, "**VOICE**" icon is flashing
- After the beep, say the message
- Release the **OK/C** button to finish the recording
- Press **PB/D** to leave the menu

**The maximum length of recording is '20' seconds**

### **TEST EMERGENCY MESSAGE**

- Press **PRO**
- Press ▲ 5 x to select "**CHECK MESSAGE**"
- Press **OK/C** to listen to the recorded message
- Press **PB/D** to leave the menu

### **TEST SYSTEM OPERATION**

First call your chosen emergency contacts to inform them they are on your emergency contact list. Instruct your contacts how to accept, extend and/or end the call with the proper procedure. After they have been informed to press 0 to accept, 1+5 to extend and 1+9 to terminate, press the Pendant button or the SOS button to perform an actual test. Now you can proceed with other features (i.e. contact name recording, etc.)

# ATS Model PAVDII User Manual



## 1 FEATURES LIST

### 1.1 Emergency Features:

- Activates alarm for 15 seconds for immediate help within the house (begins phone contact after 15 seconds)
- If no help arrives, the phone dials in sequential order, the assigned emergency numbers from the phone book (up to 30)
- Plays a pre-recorded or user recorded emergency message
- When the receiver answers the call and presses '0', a 2 minute speakerphone conversation will be activated
- Before the end of 2 minutes, receiver will hear 2 beeps and can press 1+5 to continue the conversation for another 2 minutes or after 2 minutes, the phone will dial the next emergency number from the phone book
- During the emergency conversation, the receiving party can press 1+9 to disconnect or caller can press Pendant or SOS button
- If the called party does not answer after **1 minute**, system proceeds to call the next emergency contact
- The emergency call can work with system phone off-hook with wireless pendant only
- Pendant control range is over 100 feet in open area
- Pendant is totally waterproof

## 6.8 USING DIRECT MEMORY KEYS M1, 911

- Press **M1** or **911**
- Press **OK/☎** to dial number, or
- Pick up handset or press **☎** for hands-free mode
- Press **M1** or **911** to dial direct memory number

## 7 SOS FUNCTION

Read carefully how **SOS** works – 1.1 Emergency Features

### 7.1 ACTIVATE SOS FUNCTION

- Press the Pendant button, or
- Press and hold **SOS** key on telephone for at least 3 seconds

#### NOTE:

If Pendant or SOS is accidentally pressed, pressing again with 15 seconds will deactivate and not call emergency contacts.

\*If telephone receiver is off the hook, emergency system will work with the wireless Pendant only

### 7.2 DEACTIVATE SOS FUNCTION

- Press the Pendant button
- Press **SOS** key on telephone

### 7.3 RECEIVING PARTY COMMANDS / KEY CODES

Press 0	accept the emergency call
Press 1+5	extend the call for another 2 minutes
Press 1+9	deactivate and terminate the emergency call

## 6.7 USING PHONEBOOK

- To go to phonebook mode, press **PB/D** to make sure  is displayed on screen, next to the date
- Use **▲** and **▼** to navigate through the phonebook

**SOS will appear in front of clock in display for emergency numbers**

### 6.7.1 MAKING CALLS FROM PHONEBOOK

- Select a number from the phonebook
- Press **OK/C** to dial the number

### 6.7.2 EDIT NUMBER / NAME IN PHONEBOOK

- Select a number from the phonebook
- Press and hold **PRO** until “**EDIT ?**” appears on display
- Press **OK/C**
- Start modifying number, name and emergency type according to Chapter “5.8 Store Telephone Numbers”  
Refer to Chapter “5.9 Name Recording” to record a name

### 6.7.3 DELETE NUMBER FROM PHONEBOOK

- Select a number from the phonebook
- Press **DEL** – “**DELETE ?**” will appear in display
- Press and HOLD **DEL** for 3 seconds – number will be deleted



### 6.7.4 DELETE ALL NUMBERS FROM PHONEBOOK

- In phonebook, press and hold **DEL** for 3 seconds – “**DELETE ALL ?**” will appear in the display
- Again press and HOLD **DEL** for 3 seconds – all numbers will be deleted



## 1.2 TELEPHONE AND CID FEATURES

- FSK/DTMF Emergency Talking Caller ID Speakerphone
- Languages Selectable: English / French / German / Spanish / Italian / Dutch / Swedish / Finnish / Danish / Polish / Portuguese
- Voice Reporting Selectable: English / French / German / Spanish / Italian / Dutch
- Up to 64 messages memory
- 22 digits for telephone numbers and 16 digits for name display capable
- Built-in phonebook holds up to 30 numbers
- Real time clock display
- (2) one-touch memory buttons (M1 and 911)
- (5) levels of LCD contrast adjustment
- Flash time 100/300/600ms selectable
- Tone / Pulse selectable
- In-use indicator
- Low and no battery indicator on display (must install 4 AA Alkaline LR6 – *not included*)
- Ringer volume control
- Ringer light
- Handset volume control
- Speakerphone volume control
- LCD back light
- External power: DC 9V 300mA adaptor
- Pendant operating frequency: 433.92 MHz
- Pendant battery: 23A 12V Alkaline
- Program key ON/OFF switch control
- Wall mountable

## 2 BUTTONS / CONNECTIONS (See picture)

1. LCD display
2. Direct memory key M1
3. Direct memory key 911
4. OK / Dial Key 
5. Up key (▲)
6. Down key (▼)
7. Program key (PRO)
8. Delete key (DEL)
9. Phonebook / Caller ID list / Exit / Select key (PB/D)
10. Hands-free volume (slide bar) (below PB/D key)
11. Hands-free key 
12. Redial / Pause key (RD/P)
13. Ringer LED
14. Flash key (FLASH)
15. Mute key (MUTE)
16. Curl cord connector (RJ9)
17. Numeric keypad
18. SOS key
19. Low battery / No battery LED
20. Hook switch
21. In-use LED
22. Program key ON/OFF switch
23. Ringer volume switch
24. Line connection (RJ11)
25. Power adapter connection
26. Curl cord connection (RJ9)
27. Handset volume switch
28. Wireless pendant
29. Pendant SOS button
30. Pendant transmission LED

### 6.6.1 MAKING CALLS FROM CALLER ID LIST

- Press 
- Arrow down ▼ to select number from caller ID list
- Press  2 x to dial number

### 6.6.2 COPY NUMBER FROM CALLER ID LIST TO PHONEBOOK

- Select number from caller ID list
- Press and hold **PRO** for 2 seconds – “**COPY TO MEMORY**” will be displayed
- Press  to store number

### 6.6.3 DELETE NUMBER FROM CALLER ID LIST

- Select number from caller ID list
- Press **DEL** – “**DELETE ?**” will appear on display
- Press and hold **DEL** for 3 seconds – number will be deleted

### 6.6.4 DELETE ALL NUMBERS FROM CALLER ID LIST

- In caller ID list press and hold **DEL** for 3 seconds – “**DELETE ALL ?**” will appear on display
- Press and hold **DEL** for 3 seconds – all numbers will be deleted

## RECEIVING CALLER ID INFORMATION

Incoming call display will display number, area code, name, time and date of call. If provided by telephone company, you may see:

“**OUT OF AREA**” – call is made through telephone company which does not offer Caller ID service or does not transfer calls by long distance net

“**PRIVATE CALL**” – some areas allow callers to prevent their telephone data from being displayed

### 6.3 DEACTIVATING MICROPHONE

During a call, you can deactivate the microphone and talk freely without the caller hearing you

- Press and hold **MUTE** to mute the microphone

### 6.4 FLASH FUNCTION

If dialing number is busy or conversation is complete, press **FLASH** key to disconnect line for dialing another number

When equipped with PABX, telephone makes it easy to transfer calls

- Press **FLASH** key for call waiting
- Dial extension number of caller intended
- When party answers, hang up handset
- When line is busy or no answer, press **FLASH** again to reconnect to caller

### 6.5 LAST NUMBER REDIAL

The telephone will remember the last number dialed

- Pick up handset or press **■** for hands-free
- Press **RD/P** to redial last number called

### 6.6 INCOMING CALLER ID LIST

The telephone can store up to 64 calls in the caller ID list  
The display will show total of calls and number of new calls

To review incoming calls, press **PB/D** to make sure “**CLIP**” is displayed next to date on display  
Use **▲** and **▼** to navigate through incoming calls

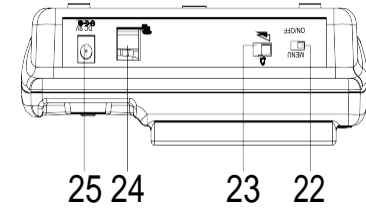

19 21 2 3 4

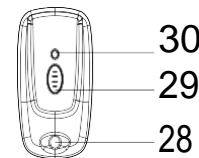
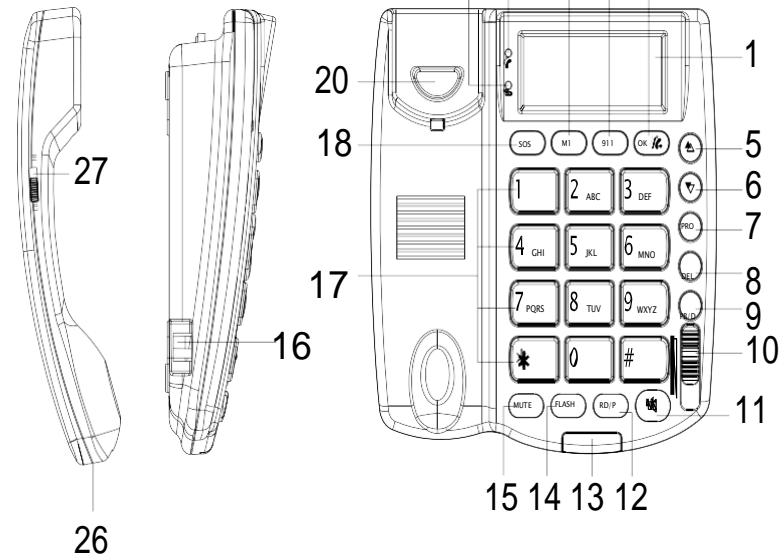

30 Pendant battery 12v Alkaline CN23A  
(included in pendant)

### 3 INSTALLATION

**Telephone line needs to be disconnected prior to opening the battery compartment!**

Put batteries in battery compartment to activate display

- Unscrew battery compartment on bottom of telephone
- Insert 4 Alkaline AA (LR06, 1.5V) batteries (*not included*)
- Close battery compartment
- Connect one end of telephone line cord to telephone wall jack and other end to back of telephone
- Connect power adapter to connection on back of telephone and to available power outlet
- If you do not install batteries, the “Low Battery / No Battery” LED will continue to flash
- When replacing batteries, pick up handset first, then replace batteries – otherwise time clock setting will be lost
- System will run on battery power for emergencies

### 4 DESCRIPTION OF DISPLAY

Upper line displays basic information, middle line displays telephone number and bottom line displays name of caller

-  is Low or No battery indicator
- “REPEAT” means the repeat of an incoming call
- “VOICE” means voice reporting indicator
- “NEW” means there are new incoming calls
- “SOS” means emergency calls
- “XX:XX XX/XX” means Hour / Minute - Month / Date

### 5 USING TELEPHONE

#### 6.1 MAKING CALLS

- Enter telephone number
- Press **DEL** to delete wrong entered number
- Press **OK/☎** or  to make hands-free call or,
- Pick up handset to off-hook and enter telephone number

**Volume of handset can be set HI or LOW (27)**

**During call made with handset, you can switch to hands-free by pressing  and hanging up handset. Hands-free volume is adjusted using button (10)**

**In case telephone is connected to PBX system it may be necessary to add a Pause after PBX access code. Telephone can generate a ‘4’ second Pause time.  
EX: 0 P 012345678  
Press RD/P to enter a Pause**

Call duration timer will start in display 4 seconds after number is dialed.

#### 6.2 RECEIVING CALLS

When a call comes in, phone will ring and ringer LED will blink

Pick up handset or press  or Pendant to answer hands-free

**Use switch (23) to set ringer volume**

**A call that has been accepted by use of the pendant can also be terminated by pressing the pendant again**



## 5.11 CHECK EMERGENCY MESSAGE

The message you recorded in previous Chapter can be verified

- Press **PRO**
- Press **▲** 5 x to select “**CHECK MESSAGE**”
- Press **OK/⏏** to listen to recorded message
- Press **PB/D** to leave menu

**To erase recording, press DEL during playback**

After all programming is complete, you can switch program lock ON (22)

## 5.12 PAIR NEW PENDANT / REMOVE ALL PENDANTS

The pendant is registered in the telephone by its ID Code. In case of repair or other reason, it can be necessary to register the pendant to the telephone. The pendant can also be deleted from the telephone. A total of (5) pendants can be paired to the system.

To pair a pendant:

- Press **PRO**
- Press **▼** 2 x to select “**PAIR NEW PENDANT**”
- Press **OK/⏏** “**PAIRING**” will be displayed
- Press **OK/⏏** to start pairing process
- Press button on pendant
- “**DONE**” will appear if pairing is successful
- Press **PB/D** to leave menu

To remove a pendant:

- Press **PRO**
- Press **▼** 2 x to select “**PAIR NEW PENDANT**”
- Press **OK/⏏** “**PAIRING**” will be displayed
- Press **▲** or **▼** to select “**DELETE ?**”
- Press **OK/⏏** to delete all pendants
- Press **PB/D** to leave menu

-  is phonebook indicator
- “**CLIP**” means incoming Caller ID list
- “**CALL #**” means total number of incoming calls

- A. If time and date of incoming calls is different from telephone company, telephone will adjust the time and date automatically according to Telecom Provider when receiving calls
- B. If there is no operation or no incoming calls longer than 20 seconds, LCD only displays time and date, total number of received calls and number of new incoming calls
- C. Telephone can store up to 64 incoming calls. If there is a new call after the 64<sup>th</sup> call, the oldest call will be erased automatically and new call will be stored.

## 6 SETTINGS

Settings for PROGRAM (**PRO**) menu switch (22)

- LCD Contrast (see 5.3)
- Enter Time / Date (see 5.4)
- Store Number (see 5.8)
- Name Recording (see 5.9)
- Check Message (see 5.10)
- LCD Language (see 5.1)
- Voice (see 5.2)
- Set Flash Time (see 5.7)
- Set Dial Mode (see 5.6)
- Pair New Pendant (see 5.12)
- Local Area Code (see 5.5)

## 5.1 LANGUAGE SETTING

The telephone has (11) display languages: English (ENGLISH), French (FRANCAIS), German (DEUTSCH), Spanish (ESPANOL), Italian (ITALIANO), Dutch (NEDERLANDS), Swedish (SVENSKA), Finnish (SUOMI), Danish (DANSK), Polish (POLSKI) and Portuguese (PORTUGUES).

To select the language follow these steps:

- Press **PRO**
- Press ▲ 6 x to select “**LCD LANGUAGE**”
- Press **OK/C** to enter the settings
- Use ▲ and ▼ to select the languages
- Press **OK/C** to confirm
- Press **PB/D** to leave menu

## 5.2 VOICE GUIDANCE

The telephone has a voice guided menu and will also repeat every dialed digit by voice. You can select from six different voice languages: English (ENGLISH), French (FRENCH), German (GERMAN), Spanish (SPANISH), Italian (ITALIAN), Dutch (DUTCH) or disable the voice.

- Press **PRO**
- Press ▲ 7 x to select “**VOICE**”
- Press **OK/C** to enter settings
- Use ▲ and ▼ to select voice guidance
- Press **OK/C** to confirm

**If you don't want voice guidance,  
select “VOICE NO”**

- Press **PB/D** to leave menu

## 5.9 NAME RECORDING

Once a number / name is stored, you can record the name. You can change the name you have recorded while storing a number / name in previous Chapter.

- Press **PRO**
- Press ▲ 3 x to select “**NAME RECORDING**”
- Press **OK/C** to enter
- Use ▲ or ▼ to navigate through all stored numbers / names

**You will hear recorded name while navigating through stored contacts. Press DEL to erase recording.**

- When you have selected the contact, press and hold **OK/C** and wait for the beep - “**VOICE**” icon will flash
- After the beep, say the name of stored contact
- Release the **OK/C** button to finish recording
- Press **PB/D** to leave menu

**Maximum length of recording is ‘3’ seconds**

## 5.10 RECORD MESSAGE

For **SOS** calls, the telephone will broadcast a standard pre-recorded message unless you record your own message.

- Press **PRO**
- Press ▲ 4 x to select “**RECORD MESSAGE**”
- Press and hold **OK/C** , wait for beep – “**VOICE**” icon will flash
- After the beep, record your message
- Release the **OK/C** button to finish recording
- Press **PB/D** to leave menu

**The maximum length of recording is ‘20’ seconds**

**The default message is: “THIS IS AN EMERGENCY CALL  
TO ACCEPT THIS CALL PRESS ZERO”**

### 5.8.1 STORE NUMBER IN DIRECT MEMORY KEY (M1)

- Press **PRO**
- Press **▲** 2 x to select “**STORE NUMBER**”
- Press **OK/↵** to enter
- Enter telephone number to be stored
- Press **DEL** to delete wrong entered digit
- Use **▲** and **▼** to move back and forward through number
- Press **OK/↵** to confirm
- Press **M1** key
- Press **OK/↵** to save
- Press **PB/D** to leave menu

### CHANGE 911 KEY

The 911 key is pre-programmed from the factory. If you need to change the 911 key, you may program another number following these steps:

- Press **PRO**
- Press **▲** 2 x to select “**STORE NUMBER**”
- Press **OK/↵** to enter
- Enter telephone number to be stored
- Press **DEL** to delete a wrong entered digit
- Use **▲** and **▼** to move back and forward through number
- Press **OK/↵** to confirm
- Press **911** key
- Press **OK/↵** to save
- Press **PB/D** to leave menu

### 5.3 LCD CONTRAST

You can set the LCD display contrast to 5 different levels:

- Press **PRO**
- Press **OK/↵** to select “**LCD CONTRAST**”
- Use **▲** and **▼** to select desired level
- Press **OK/↵** to confirm
- Press **PB/D** to leave menu

### 5.4 ENTER TIME AND DATE

When you have subscription to Caller ID service and your telephone provider sends date and time together with telephone number, the phone's clock will be set automatically.

- Press **PRO**
- Press **▲** 1 x to select “**ENTER TIME / DATE**”
- Press **OK/↵** to enter settings
- Use **▲** and **▼** to change hour
- Press **OK/↵** to confirm
- Use **▲** and **▼** to change minutes
- Press **OK/↵** to confirm
- Use **▲** and **▼** to change month
- Press **OK/↵** to confirm
- Use **▲** and **▼** to change date
- Press **OK/↵** to confirm
- Press **PB/D** to leave menu

### 5.5 SET AREA CODE

When you have subscription to Caller ID service, it can be necessary in some countries to enter your area code. You can set up to 5 digits for the area code.

- Press **PRO**
- Press **▼** 1 x to select “**LOCAL AREA CODE**”

- Press **OK/⏏** to enter settings
- Use **▲** and **▼** to change digit
- Press **OK/⏏** to move to next digit
- Repeat this sequence until all digits are set. Leave unused digits as “-“
- Press **PB/D** to leave menu

### 5.6 SET DIAL MODE – PULSE OR TONE (DTMF)

The telephone can dial in Tone (DTMF) or Pulse mode. By default the telephone is set to Tone (DTMF) mode.

- Press **PRO**
- Press **▼** 3 x to select “**SET DIAL MODE**”
- Press **OK/⏏** to enter settings
- Use **▲** and **▼** to select “**PULSE**” or “**TONE**”
- Press **OK/⏏** to confirm
- Press **PB/D** to leave menu

### 5.7 SET FLASH TIME

Flash is used for services like “call waiting” (if service is provided by telephone company) or to transfer calls when connected to PBX system.

Depending on the country, flash time can vary. The telephone supports (3) possibilities: 100, 300, 600 msec

- Press **PRO**
- Press **▼** 4 x to select “**SET FLASH TIME**”
- Press **OK/⏏** to enter settings
- Use **▲** and **▼** to select desired flash time
- Press **OK/⏏** to confirm
- Press **PB/D** to leave menu

### 5.8 STORE TELEPHONE / PHONEBOOK NUMBERS

You can store up to 30 phone numbers / names in the telephone. As few as 1 or all 30 numbers can be set as emergency numbers. NOTE: If storing 911 in emergency contact list, store as the last emergency contact.

- Press **PRO**
- Press **▲** 2 x to select “**STORE NUMBER**”
- Press **OK/⏏** to enter
- Enter telephone number to be stored

NOTE: To store a **pause** while programming, press **RD/P**

To store a \* or # while programming, press those keys

- Press **DEL** to delete a wrong entered number
  - Use **▲** and **▼** to move back and forward through number
  - Press **OK/⏏** to confirm
  - Enter name using characters on numeric keypad
  - Press **DEL** to delete a wrong entered character
  - Use **▲** and **▼** to move back and forward through entered characters
  - Press **OK/⏏** to confirm
  - Select “**EMERGENCY OFF**” or “**EMERGENCY ON**”
- In case of “**EMERGENCY ON**” you need to select position of this number (specifies in what order it will be dialed)
- Use **▲** and **▼** to select position
  - Press **OK/⏏** to confirm

In case you want to overwrite an existing position, you will have to confirm “**OVERWRITE?**” by pressing **OK/⏏**. When number is saved, menu will automatically go to “**NAME RECORDING**”

- Press and hold **OK/⏏** and wait for a beep
- After the beep, say name of stored contact
- Release **OK/⏏** button to finish recording
- Press **PB/D** to leave menu

The maximum length of the recording is ‘3’ seconds