

### Parts Diagram and Parts Listing: S270T2, S310T2, S360T2

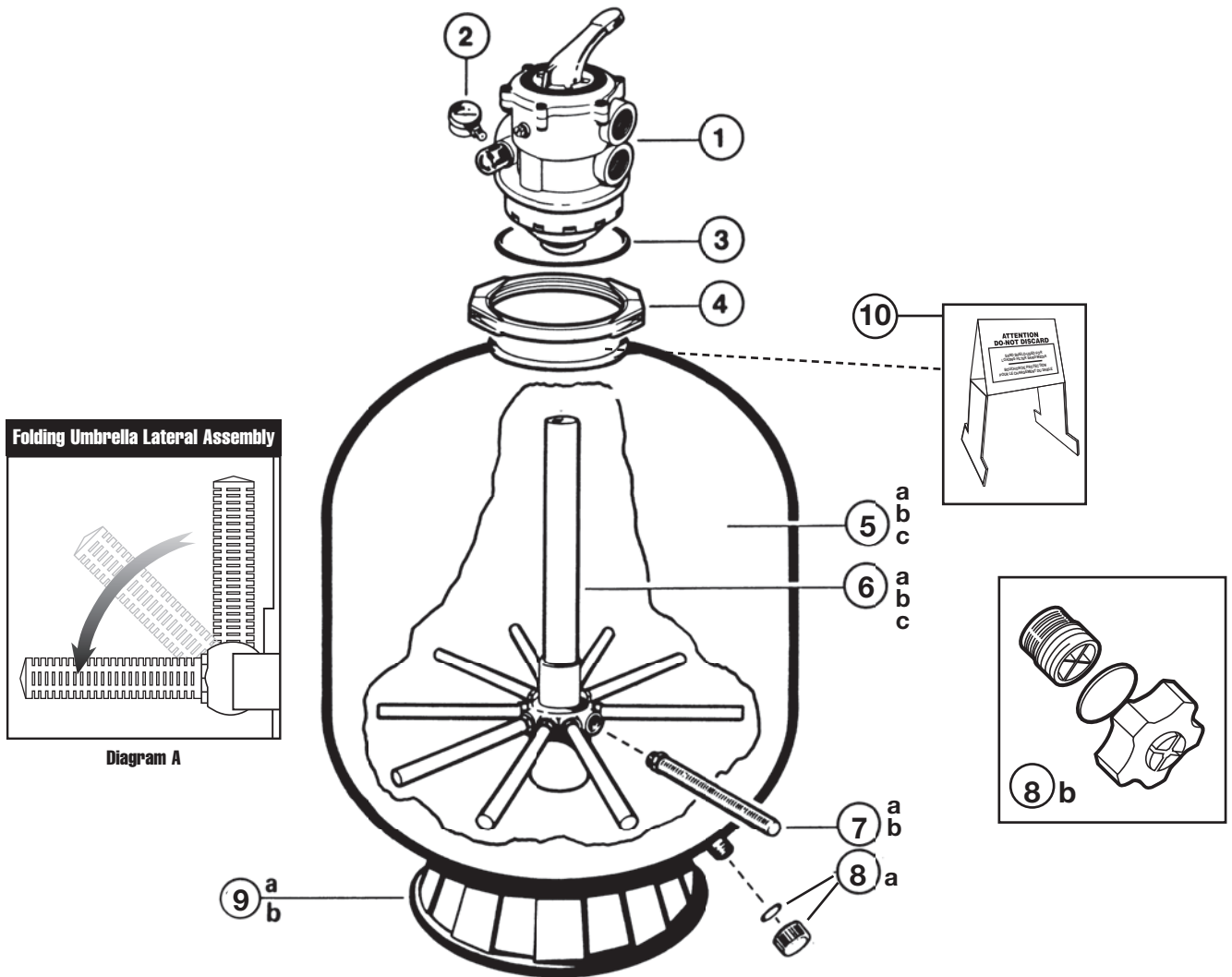

Ref. No.	Part No.	Description	Ctn. Qty.	No. Req'd
1	SP071620T	Vari-Flo Control Valve – 2" w/Clamp	1	1
2	ECX271261	Pressure Gauge Back Mount	10	1
3	GMX600F	Valve/Tank O-Ring	10	1
4	GMX600NM	Flange Clamp (Valve – Tank)	5	1
5a	SX270AA	27" Filter Tank w/Skirt, Drain and Lateral Assembly	1	1
5b	SX310AA1	31" Filter Tank w/Skirt, Drain and Lateral Assembly	1	1
5c	SX360AA2	36" Filter Tank w/Skirt, Drain and Lateral Assembly	1	1
6a	SX244DA	27" Folding Lateral Assembly w/Center Pipe	1	1
6b	SX310DA2	31" Folding Lateral Assembly w/Center Pipe	1	1
6c	SX360DA	36" Folding Lateral Assembly w/Center Pipe	1	1
7a	SX240DN	27" Lateral (One Piece) w/Hub	10	10
7b	SX310HA	31" & 36" Lateral (2004 and prior)	10	10
7c	SX310HN	31" & 36" Lateral (One Piece) w/Hub	10	10
8a	SX180HG	Drain Cap (2005 and prior)	25	1
8b	SX180LA	Drain Cap Assembly, Gasket, Screen	25	1
9a	SX200J	27" Filter Support Stand	2	1
9b	SX310J	Filter Support Stand – Large	1	1
10	SX202S	Sand Shield	25	1
-	SPX0710MA	Sight Glass w/ O-Ring		

**NOTE:** Spare part body 27" & 36" with lateral assembly and filter support stand need BOM.



# Pro™ Series

S180T, 210T, 220T, 230T, 244T, S270T SAND FILTER SERIES REPLACEMENT PARTS

## Parts Diagram

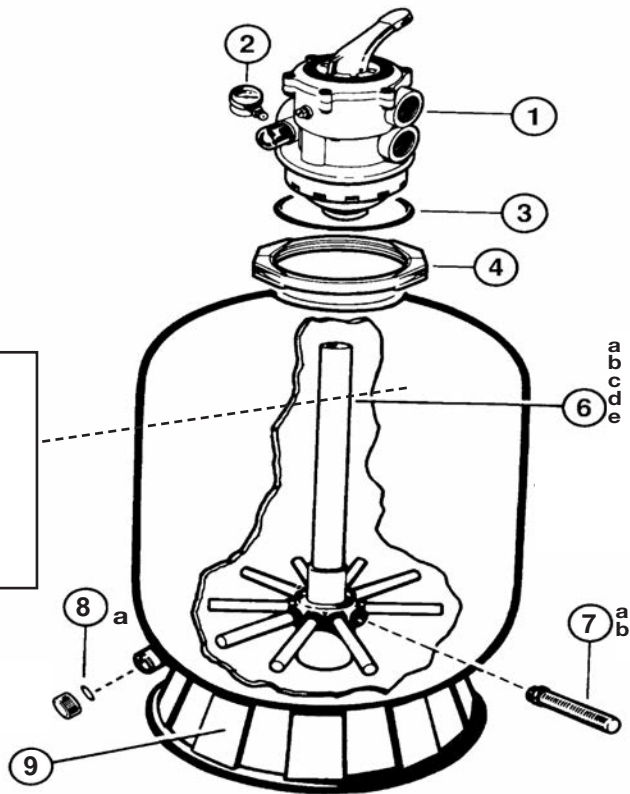
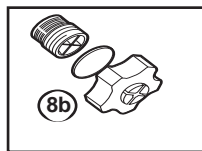
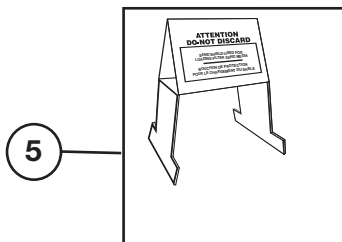
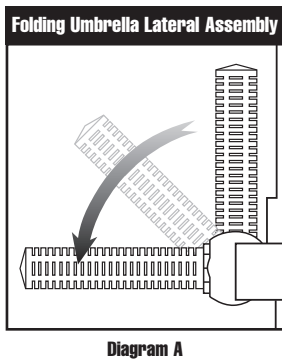
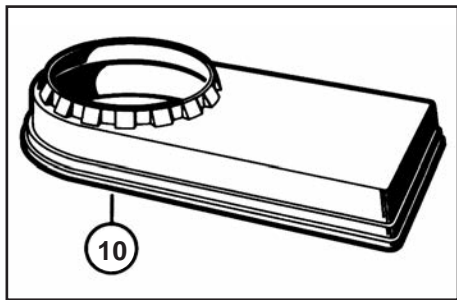

## Parts List

Ref. No.	Part No.	Description	Ctn. Qty.	No. Req'd
1	SP0714T	Vari-Flo XL Control Valve – 1 1/2"	1	1
2	ECX270861	Pressure Gauge	10	1
3	GMX600F	Valve/Tank O-Ring	10	1
4	GMX600NM	Flange Clamp, Noryl	5	1
5	SX202S	Sand Shield – 2004 Corrugated Design	25	1
6a	SX180DA	Folding Umbrella Lateral Assembly w/Center Pipe (S180T) (1997- )	1	1
6b	SX210DA	Folding Umbrella Lateral Assembly w/Center Pipe (S210T) (1997- )	1	1
6c	SX220DA	Folding Umbrella Lateral Assembly w/Center Pipe (S220T) (1997- )	1	1
6d	SX220DA	Folding Umbrella Lateral Assembly w/Center Pipe (S230T) (2003- )	1	1
6e	SX244DA	Folding Umbrella Lateral Assembly w/Center Pipe (S244T, S270T) (1997- )	1	1
7a	SX200Q	Lateral (S180T) (2004 and Prior)	10	10
7b	SX240D	Lateral (S210T, S220T, S230T, S244T) (2004 and Prior)	10	10
7c	SX200QN	Lateral (One Piece) w/Hub See Diag. A	10	10
7d	SX240DN	Lateral (One Piece) w/Hub See Diag. A	10	10
8a	SX180HG	Drain Cap Kit (2005 and prior)	25	1
8b	SX180LA	Drain Cap Assembly – Cap, Gasket, Screen	1	1
9	SX200J	Filter Support Stand (Skirt)	2	1
10	SX180K	System Base – S180T Systems	2	1
-	SPX0710MA	Sight Glass w/ O-Ring		

Filter's