

Version 1.0

Published November 2013

Copyright©2013 ASRock INC. All rights reserved.



## Copyright Notice:

No part of this documentation may be reproduced, transcribed, transmitted, or translated in any language, in any form or by any means, except duplication of documentation by the purchaser for backup purpose, without written consent of ASRock Inc.

Products and corporate names appearing in this documentation may or may not be registered trademarks or copyrights of their respective companies, and are used only for identification or explanation and to the owners' benefit, without intent to infringe.

## Disclaimer:

Specifications and information contained in this documentation are furnished for informational use only and subject to change without notice, and should not be constructed as a commitment by ASRock. ASRock assumes no responsibility for any errors or omissions that may appear in this documentation.

With respect to the contents of this documentation, ASRock does not provide warranty of any kind, either expressed or implied, including but not limited to the implied warranties or conditions of merchantability or fitness for a particular purpose.

In no event shall ASRock, its directors, officers, employees, or agents be liable for any indirect, special, incidental, or consequential damages (including damages for loss of profits, loss of business, loss of data, interruption of business and the like), even if ASRock has been advised of the possibility of such damages arising from any defect or error in the documentation or product.



This device complies with Part 15 of the FCC Rules. Operation is subject to the following two conditions:

- (1) this device may not cause harmful interference, and
- (2) this device must accept any interference received, including interference that may cause undesired operation.

## CALIFORNIA, USA ONLY

The Lithium battery adopted on this motherboard contains Perchlorate, a toxic substance controlled in Perchlorate Best Management Practices (BMP) regulations passed by the California Legislature. When you discard the Lithium battery in California, USA, please follow the related regulations in advance.

“Perchlorate Material-special handling may apply, see [www.dtsc.ca.gov/hazardouswaste/perchlorate](http://www.dtsc.ca.gov/hazardouswaste/perchlorate)”

**ASRock Website: <http://www.asrock.com>**

Manufactured under license under U.S. Patent Nos: 5,956,674; 5,974,380; 6,487,535;  
7,003,467 & other U.S. and worldwide patents issued & pending. DTS, the Symbol, &  
DTS and the Symbol together is a registered trademark & DTS Connect, DTS Interactive,  
DTS Neo:PC are trademarks of DTS, Inc. Product includes software.

© DTS, Inc., All Rights Reserved.





## Fatal1ty Story

---

Who knew that at age 19, I would be a World Champion PC gamer. When I was 13, I actually played competitive billiards in professional tournaments and won four or five games off guys who played at the highest level. I actually thought of making a career of it, but at that young age situations change rapidly. Because I've been blessed with great hand-eye coordination and a grasp of mathematics (an important element in video gaming) I gravitated to that activity.

### GOING PRO

I started professional gaming in 1999 when I entered the CPL (Cyberathlete Professional League) tournament in Dallas and won \$4,000 for coming in third place. Emerging as one of the top players in the United States, a company interested in sponsoring me flew me to Sweden to compete against the top 12 players in the world. I won 18 straight games, lost none, and took first place, becoming the number one ranked Quake III player in the world in the process. Two months later I followed that success by traveling to Dallas and defending my title as the world's best Quake III player, winning the \$40,000 grand prize. From there I entered competitions all over the world, including Singapore, Korea, Germany, Australia, Holland and Brazil in addition to Los Angeles, New York and St. Louis.

### WINNING STREAK

I was excited to showcase my true gaming skills when defending my title as CPL Champion of the year at the CPL Winter 2001 because I would be competing in a totally different first person shooter (fps) game, Alien vs. Predator II. I won that competition and walked away with a new car. The next year I won the same title playing Unreal Tournament 2003, becoming the only three-time CPL champion of the year. And I did it playing a different game each year, something no one else has ever done and a feat of which I am extremely proud.

At QuakeCon 2002, I faced off against my rival ZeRo4 in one of the most highly anticipated matches of the year, winning in a 14 to (-1) killer victory. Competing at Quakecon 2004, I became the World's 1st Doom3 Champion by defeating Daler in a series of very challenging matches and earning \$25,000 for the victory.

Since then Fatal1ty has traveled the globe to compete against the best in the world, winning prizes and acclaim, including the 2005 CPL World Tour Championship in New York City for a \$150,000 first place triumph. In August 2007, Johnathan was awarded the first ever Lifetime Achievement Award in the four year history of the eSports-Award for "showing exceptional sportsmanship, taking part in shaping eSports into what it is today and for being the prime representative of this young sport. He has become the figurehead for eSports worldwide".

## LIVIN' LARGE

Since my first big tournament wins, I have been a “Professional Cyberathlete”, traveling the world and livin’ large with lots of International media coverage on outlets such as MTV, ESPN and a 60 Minutes segment on CBS to name only a few. It’s unreal - it’s crazy. I’m living a dream by playing video games for a living. I’ve always been athletic and took sports like hockey and football very seriously, working out and training hard. This discipline helps me become a better gamer and my drive to be the best has opened the doors necessary to become a professional.

## A DREAM

Now, another dream is being realized – building the ultimate gaming computer, made up of the best parts under my own brand. Quality hardware makes a huge difference in competitions...a couple more frames per second and everything gets really nice. It’s all about getting the computer processing faster and allowing more fluid movement around the maps.

My vision for Fatal1ty hardware is to allow gamers to focus on the game without worrying about their equipment, something I’ve preached since I began competing. I don’t want to worry about my equipment. I want to be there – over and done with - so I can focus on the game. I want it to be the fastest and most stable computer equipment on the face of the planet, so quality is what Fatal1ty Brand products represent.



Johnathan “Fatal1ty” Wendel



# Motherboard Layout

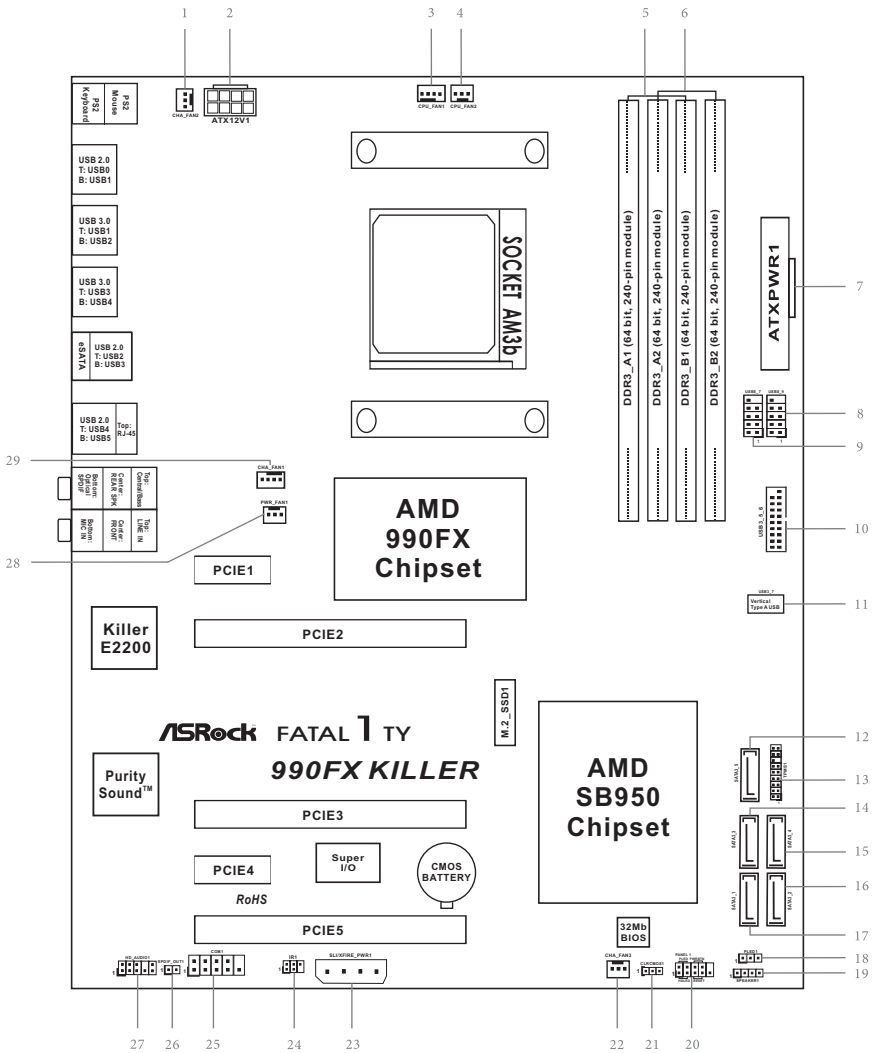

No.	Description
1	Chassis Fan Connector (CHA_FAN2)
2	ATX 12V Power Connector (ATX12V1)
3	CPU Fan Connector (CPU_FAN1)
4	CPU Fan Connector (CPU_FAN2)
5	2 x 240-pin DDR3 DIMM Slots (DDR3_A1, DDR3_B1)
6	2 x 240-pin DDR3 DIMM Slots (DDR3_A2, DDR3_B2)
7	ATX Power Connector (ATXPWR1)
8	USB 2.0 Header (USB8_9)
9	USB 2.0 Header (USB6_7)
10	USB 3.0 Header (USB3_5_6)
11	Vertical Type A USB 3.0 (USB3_7)
12	SATA3 Connector (SATA3_5)
13	TPM Header (TPMS1)
14	SATA3 Connector (SATA3_3)
15	SATA3 Connector (SATA3_4)
16	SATA3 Connector (SATA3_2)
17	SATA3 Connector (SATA3_1)
18	Power LED Header (PLED1)
19	Chassis Speaker Header (SPEAKER1)
20	System Panel Header (PANEL1)
21	Clear CMOS Jumper (CLRCMOS1)
22	Chassis Fan Connector (CHA_FAN3)
23	SLI/XFIRE Power Connector (SLI/XFIRE_PWR1)
24	Infrared Module Header (IR1)
25	COM Port Header (COM1)
26	SPDIF Out Connector (SPDIF_OUT1)
27	Front Panel Audio Header (HD_AUDIO1)
28	Power Fan Connector (PWR_FAN1)
29	Chassis Fan Connector (CHA_FAN1)

## I/O Panel

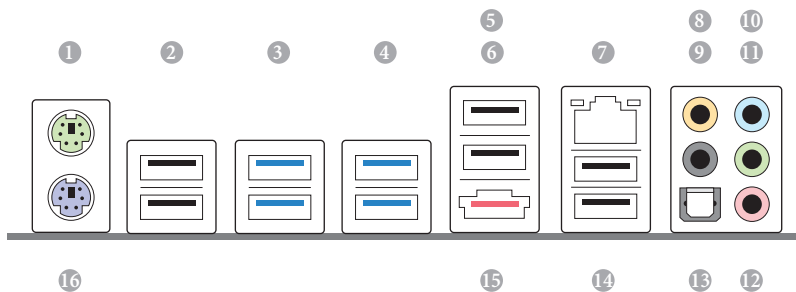

No.	Description	No.	Description
1	PS/2 Mouse Port	9	Rear Speaker (Black)
2	USB 2.0 Ports (USB_01)	10	Line In (Light Blue)
3	USB 3.0 Ports (USB3_12)	11	Front Speaker (Lime)**
4	USB 3.0 Ports (USB3_34)	12	Microphone (Pink)
5	Fatal1ty Mouse Port (USB2)	13	Optical SPDIF Out Port
6	USB 2.0 Port (USB3)	14	USB 2.0 Ports (USB_45)
7	LAN RJ-45 Port*	15	eSATA3 Port (ESATA1)***
8	Central / Bass (Orange)	16	PS/2 Keyboard Port

\* There are two LEDs on each LAN port. Please refer to the table below for the LAN port LED indications.

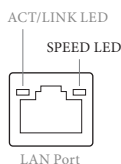

Activity / Link LED		Speed LED	
Status	Description	Status	Description
Off	No Link	Off	10Mbps connection
Blinking	Data Activity	Orange	100Mbps connection
On	Link	Green	1Gbps connection

\*\* If you use a 2-channel speaker, please connect the speaker's plug into "Front Speaker Jack". See the table below for connection details in accordance with the type of speaker you use.

Audio Output Channels	Front Speaker (No. 11)	Rear Speaker (No. 9)	Central / Bass (No. 8)	Line In (No. 10)
2	V	--	--	--
4	V	V	--	--
6	V	V	V	--
8	V	V	V	V



To enable Multi-Streaming, you need to connect a front panel audio cable to the front panel audio header. After restarting your computer, you will find the "Mixer" tool on your system. Please select "Mixer Toolbox" , click "Enable playback multi-streaming", and click "ok". Choose "2CH", "4CH", "6CH", or "8CH" and then you are allowed to select "Realtek HDA Primary output" to use the Rear Speaker, Central/Bass, and Front Speaker, or select "Realtek HDA Audio 2nd output" to use the front panel audio.

\*\*\* The eSATA3 port supports SATA Gen3 in cable 1M. The eSATA3 port is shared with M.2\_SSD (NGFF) Socket 3.

# Chapter 1 Introduction

Thank you for purchasing ASRock Fatal1ty 990FX Killer Series motherboard, a reliable motherboard produced under ASRock's consistently stringent quality control. It delivers excellent performance with robust design conforming to ASRock's commitment to quality and endurance.



*Because the motherboard specifications and the BIOS software might be updated, the content of this manual will be subject to change without notice. In case any modifications of this manual occur, the updated version will be available on ASRock's website without further notice. If you require technical support related to this motherboard, please visit our website for specific information about the model you are using. You may find the latest VGA cards and CPU support list on ASRock's website as well. ASRock website <http://www.asrock.com>.*

## 1.1 Package Contents

- ASRock Fatal1ty 990FX Killer Series Motherboard (ATX Form Factor)
- ASRock Fatal1ty 990FX Killer Series Quick Installation Guide
- ASRock Fatal1ty 990FX Killer Series Support CD
- 4 x Serial ATA (SATA) Data Cables (Optional)
- 1 x I/O Panel Shield
- 1 x ASRock SLI\_Bridge\_2S Card
- 1 x M.2\_SSD (NGFF) Socket 3 Screw

## 1.2 Specifications

- Platform**
- ATX Form Factor
  - Premium Gold Capacitor design (100% Japan-made high-quality conductive polymer capacitors)

- A-Style**
- Purity Sound™

- Gaming Armor**
- CPU Power**
- Hi-Density Power Connector

**VGA Card**

- 15µGold Finger in VGA PCIe Slots (PCIE2/PCIE3)
- SLI/CrossFireX Power Connector

**Internet**

- Qualcomm® Atheros® Killer™ LAN

**Audio**

- Purity Sound™

- CPU**
- Supports Socket AM3+ processors
  - Supports Socket AM3 processors: AMD Phenom™ II X6 / X4 / X3 / X2 (except 920 / 940) / Athlon II X4 / X3 / X2 / Sempron processors
  - Supports 8-Core CPU
  - Supports UCC feature (Unlock CPU Core)
  - Digi Power design
  - 8 + 2 Power Phase design
  - Supports CPU up to 140W
  - Supports AMD's Cool 'n' Quiet Technology
  - FSB 2600 MHz (5.2 GT/s)
  - Supports Untied Overclocking Technology
  - Supports Hyper-Transport 3.0 (HT 3.0) Technology

- Chipset**
- Northbridge: AMD 990FX
  - Southbridge: AMD SB950

- Memory**
- Dual Channel DDR3 Memory Technology
  - 4 x DDR3 DIMM Slots
  - Supports DDR3 2450(OC)/2100(OC)/1600/1333/1066 non-ECC, un-buffered memory (see CAUTION1)

- Max. capacity of system memory: 64GB (see CAUTION2)
- Supports Intel® Extreme Memory Profile (XMP) 1.3 / 1.2
- Supports AMD Memory Profile (AMP)

**Expansion Slot**

- 3 x PCI Express 2.0 x16 Slots (PCIE2/PCIE3 @ x16 mode; PCIE5 @ x4 mode)
- 2 x PCI Express 2.0 x1 Slots
- Supports AMD Quad CrossFireX™, 3-Way CrossFireX™ and CrossFireX™
- Supports NVIDIA® Quad SLI™ and SLI™

**Audio**

- 7.1 CH HD Audio with Content Protection (Realtek ALC1150 Audio Codec)
- Premium Blu-ray Audio Support
- Supports Purity Sound™
  - 115dB SNR DAC with Differential Amplifier
  - TI® NE5532 Premium Headset Amplifier (Supports up to 600 ohm headsets)
  - Direct Drive Technology
  - EMI Shielding Cover
  - PCB Isolate Shielding
- Supports DTS Connect

**LAN**

- PCIE x1 Gigabit LAN 10/100/1000 Mb/s
- Qualcomm® Atheros® Killer™ E2200 Series
- Supports Wake-On-LAN
- Supports Energy Efficient Ethernet 802.3az
- Supports PXE

**Rear Panel I/O**

- 1 x PS/2 Mouse Port
- 1 x PS/2 Keyboard Port
- 1 x Optical SPDIF Out Port
- 5 x USB 2.0 Ports
- 1 x Fatal1ty Mouse Port (USB 2.0)
- 4 x USB 3.0 Ports (ASMedia Hub)
- 1 x eSATA3 Connector

- 1 x RJ-45 LAN Port with LED (ACT/LINK LED and SPEED LED)
- HD Audio Jacks: Rear Speaker / Central / Bass / Line in / Front Speaker / Microphone

### Storage

- 5 x SATA3 6.0 Gb/s Connectors, support RAID (RAID 0, RAID 1, RAID 0+1, JBOD and RAID 5), NCQ, AHCI and Hot Plug
- 1 x M.2\_SSD (NGFF) Socket 3, supports M.2 SATA3 6.0 Gb/s module and M.2 PCI Express module up to Gen2 x2 (10 Gb/s) (M.2\_SSD (NGFF) Socket 3 is shared with the eSATA3 connector)

### Connector

- 1 x IR Header
- 1 x COM Port Header
- 1 x TPM Header
- 1 x Power LED Header
- 2 x CPU Fan Connectors (1 x 4-pin, 1 x 3-pin)
- 3 x Chassis Fan Connectors (1 x 4-pin, 2 x 3-pin)
- 1 x Power Fan Connector (3-pin)
- 1 x 24 pin ATX Power Connector
- 1 x 8 pin 12V Power Connector (Hi-Density Power Connector)
- 1 x SLI/XFire Power Connector (see CAUTION3)
- 1 x Front Panel Audio Connector
- 1 x SPDIF Out Connector
- 2 x USB 2.0 Headers (Support 4 USB 2.0 ports)
- 1 x Vertical Type A USB 3.0
- 1 x USB 3.0 Header by Etron EJ188 (Supports 2 USB 3.0 ports)

### BIOS Feature

- 32Mb AMI UEFI Legal BIOS with with GUI support
- Supports “Plug and Play”
- ACPI 1.1 Compliant wake up events
- Supports jumperfree
- SMBIOS 2.3.1 support
- CPU, DRAM, NB, HT, CPU VDDA, PCIE VDDA, CPU NB Voltage multi-adjustment

- Support CD**
- Drivers, Utilities, AntiVirus Software (Trial Version), Google Chrome Browser and Toolbar, Start8 (30 days trial), XSplit, Killer Network Manager

- Hardware Monitor**
- CPU/Chassis temperature sensing
  - CPU/Chassis/Power Fan Tachometer
  - CPU/Chassis Quiet Fan (Auto adjust fan speed by CPU temperature)
  - CPU/Chassis Fan multi-speed control
  - Voltage monitoring: +12V, +5V, +3.3V, CPU Vcore Voltage

- OS**
- Microsoft® Windows® 10 64-bit / 8.1 32-bit / 8.1 64-bit / 8 32-bit / 8 64-bit / 7 32-bit / 7 64-bit

- Certifications**
- FCC, CE, WHQL
  - ErP/EuP ready (ErP/EuP ready power supply is required)

\* For detailed product information, please visit our website: <http://www.asrock.com>



Please realize that there is a certain risk involved with overclocking, including adjusting the setting in the BIOS, applying Untied Overclocking Technology, or using third-party overclocking tools. Overclocking may affect your system's stability, or even cause damage to the components and devices of your system. It should be done at your own risk and expense. We are not responsible for possible damage caused by overclocking.



1. Whether 2450/2100MHz memory speed is supported depends on the AM3/AM3+ CPU you adopt. If you want to adopt DDR3 2450/2100 memory module on this motherboard, please refer to the memory support list on our website for the compatible memory modules. ASRock website: <http://www.asrock.com>
2. Due to the operating system limitation, the actual memory size may be less than 4GB for the reservation for system usage under Windows® 8 / 7. For Windows® 64-bit OS with 64-bit CPU, there is no such limitation. You can use ASRock XFast RAM to utilize the memory that Windows® cannot use.
3. Please plug the power cable to the SLI/XFire power connector only when you install three or more VGA cards.

## 1.3 Unique Features



### ASRock F-Stream

F-Stream is an all-in-one tool to fine-tune different system functions in a user-friendly interface, it includes Hardware Monitor, Fan Control, Overclocking, FatalIty Mouse Port, Energy Saving and XFast RAM.



### ASRock Instant Boot

ASRock Instant Boot allows you to turn on your PC in just a few seconds, provides a much more efficient way to save energy, time, money, and improves system running speed for your system. It leverages the S3 and S4 ACPI features which normally enable the Sleep/Standby and Hibernation modes in Windows® to shorten boot up time. By calling S3 and S4 at specific timing during the shutdown and startup process, Instant Boot allows you to enter your Windows® desktop in a few seconds.



### ASRock Instant Flash

ASRock Instant Flash is a BIOS flash utility embedded in Flash ROM. This convenient BIOS update tool allows you to update the system BIOS in a few clicks without preparing an additional floppy diskette or other complicated flash utility. Just save the new BIOS file to your USB storage and launch this tool by pressing <F6> or <F2> during POST to enter the BIOS setup menu to access ASRock Instant Flash. Please be noted that the USB flash drive or hard drive must use FAT32/16/12 file system.



### ASRock APP Charger

Simply by installing the ASRock APP Charger makes your iPhone/iPad/iPod Touch charge up to 40% faster than before on your computer. ASRock APP Charger allows you to quickly charge many Apple devices simultaneously and even supports continuous charging when your PC enters into Standby mode (S1), Suspend to RAM (S3), hibernation mode (S4) or power off (S5).



### ASRock XFast RAM

ASRock XFast RAM is included in F-Stream. It fully utilizes the memory space that cannot be used under Windows® 32-bit operating systems. ASRock XFast RAM shortens the loading time of previously visited websites, making web surfing faster than ever. And it also boosts the speed of Adobe Photoshop 5 times faster. Another advantage of ASRock XFast RAM is that it reduces the frequency of accessing your SSDs or HDDs in order to extend their lifespan.



## ASRock Crashless BIOS

ASRock Crashless BIOS allows users to update their BIOS without fear of failing. If power loss occurs during the BIOS updating process, ASRock Crashless BIOS will automatically finish the BIOS update procedure after regaining power. Please note that BIOS files need to be placed in the root directory of your USB disk. Only USB 2.0 ports support this feature.



## ASRock OMG (Online Management Guard)

Administrators are able to establish an internet curfew or restrict internet access at specified times via OMG. You may schedule the starting and ending hours of internet access granted to other users. In order to prevent users from bypassing OMG, guest accounts without permission to modify the system time are required.



## ASRock Internet Flash

ASRock Internet Flash downloads and updates the latest UEFI firmware version from our servers for you without entering Windows OS. Please setup network configuration before using Internet Flash.



## ASRock UEFI System Browser

ASRock System Browser shows the overview of your current PC and the devices connected.



## ASRock UEFI Tech Service

Contact ASRock Tech Service by sending a support request from the UEFI setup utility if you are having trouble with your personal computer. Users may try to choose the category of the issue they have encountered, describe the problem in detail, and then attach an optional picture or log file for our technical support team.



## ASRock Dehumidifier Function

Users may prevent motherboard damages due to dampness by enabling “Dehumidifier Function”. When enabling Dehumidifier Function, the computer will power on automatically to dehumidify the system after entering S4/S5 state.



## ASRock Easy RAID Installer

ASRock Easy RAID Installer can help you to copy the RAID driver from the support CD to your USB storage device. After copying the RAID driver to your USB storage device, please change “SATA Mode” to “RAID”, then you can start installing the OS in RAID mode.



## ASRock Easy Driver Installer

For users that don't have an optical disk drive to install the drivers from our support CD, Easy Driver Installer is a handy tool in the UEFI that installs the LAN driver to your system via an USB storage device, then downloads and installs the other required drivers automatically.



## ASRock Fast Boot

With ASRock's exclusive Fast Boot technology, it takes less than 1.5 seconds to logon to Windows 8 from a cold boot. No more waiting! The speedy boot will completely change your user experience and behavior.



## ASRock X-Boost

ASRock's X-Boost Technology is a smart auto-overclocking function and is brilliantly designed to unlock the hidden power of your CPUs. Simply press "X" when turning on the PC, X-Boost will automatically overclock the relative components to get up to 15.77% performance boost! With the smart X-Boost, overclocking CPU can become a near one-button process. \* The functionality of "Unlock CPU Cores" feature might vary by different processors.



## ASRock Restart to UEFI

Windows\* 8 brings the ultimate boot up experience. The lightning boot up speed makes it hard to access the UEFI setup. ASRock Restart to UEFI allows users to enter the UEFI automatically when turning on the PC. By enabling this function, the PC will enter the UEFI directly after you restart.



## Turbo 50 / Turbo 60 Overclocking

Simply select Turbo 50 / Turbo 60 in BIOS, the system performance will boost up to 50% / 60% increase by automatically overclocking CPU, Memory frequency and all related voltage settings!



## ASRock Good Night LED

ASRock Good Night LED technology offers you a better sleeping environment by extinguishing the unessential LEDs. By enabling Good Night LED in the BIOS, the Power/HDD LEDs will be switched off when the system is powered on. Good Night LED will automatically switch off the Power and Keyboard LEDs when the system enters into Standby/Hibernation mode as well.

## Chapter 2 Installation

This is an ATX form factor motherboard. Before you install the motherboard, study the configuration of your chassis to ensure that the motherboard fits into it.

### Pre-installation Precautions

Take note of the following precautions before you install motherboard components or change any motherboard settings.

- Make sure to unplug the power cord before installing or removing the motherboard. Failure to do so may cause physical injuries to you and damages to motherboard components.
- In order to avoid damage from static electricity to the motherboard's components, NEVER place your motherboard directly on a carpet. Also remember to use a grounded wrist strap or touch a safety grounded object before you handle the components.
- Hold components by the edges and do not touch the ICs.
- Whenever you uninstall any components, place them on a grounded anti-static pad or in the bag that comes with the components.
- When placing screws to secure the motherboard to the chassis, please do not overtighten the screws! Doing so may damage the motherboard.

## 2.1 Installing the CPU



*Unplug all power cables before installing the CPU.*

1

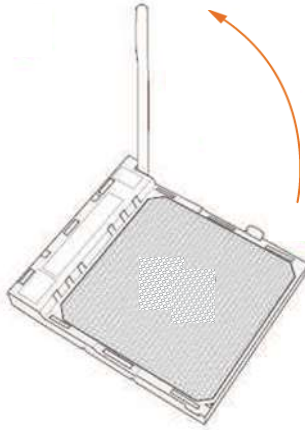

2

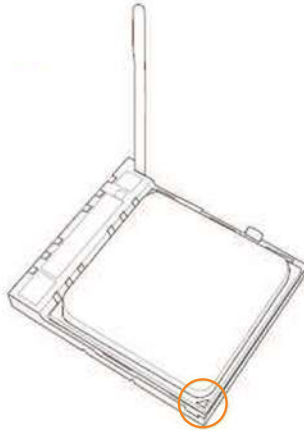

3



## 2.2 Installing the CPU Fan and Heatsink

After you install the CPU into this motherboard, it is necessary to install a larger heatsink and cooling fan to dissipate heat. You also need to spray thermal grease between the CPU and the heatsink to improve heat dissipation. Make sure that the CPU and the heatsink are securely fastened and in good contact with each other. Then connect the CPU fan to the CPU FAN connector. For proper installation, please kindly refer to the instruction manuals of the CPU fan and the heatsink.

## 2.3 Installing Memory Modules (DIMM)

This motherboard provides four 240-pin DDR3 (Double Data Rate 3) DIMM slots, and supports Dual Channel Memory Technology.



1. For dual channel configuration, you always need to install identical (the same brand, speed, size and chip-type) DDR3 DIMM pairs.
2. It is unable to activate Dual Channel Memory Technology with only one or three memory module installed.
3. It is not allowed to install a DDR or DDR2 memory module into a DDR3 slot; otherwise, this motherboard and DIMM may be damaged.
4. Please install the memory module into DDR3\_A2 and DDR3\_B2 slots for the first priority.
5. If you adopt DDR3 2450/2100 memory modules on this motherboard, it is recommended to install them on DDR3\_A2 and DDR3\_B2 slots.

### Dual Channel Memory Configuration

Priority	DDR3_A1	DDR3_A2	DDR3_B1	DDR3_B2
1		Populated		Populated
2	Populated		Populated	
3	Populated	Populated	Populated	Populated



*The DIMM only fits in one correct orientation. It will cause permanent damage to the motherboard and the DIMM if you force the DIMM into the slot at incorrect orientation.*

1

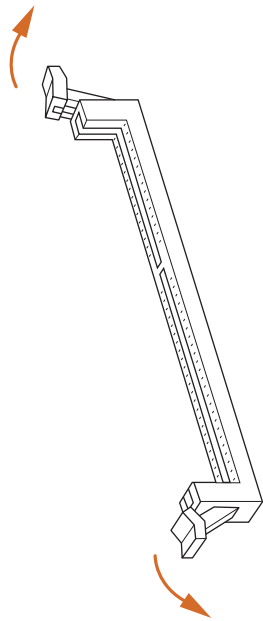

2

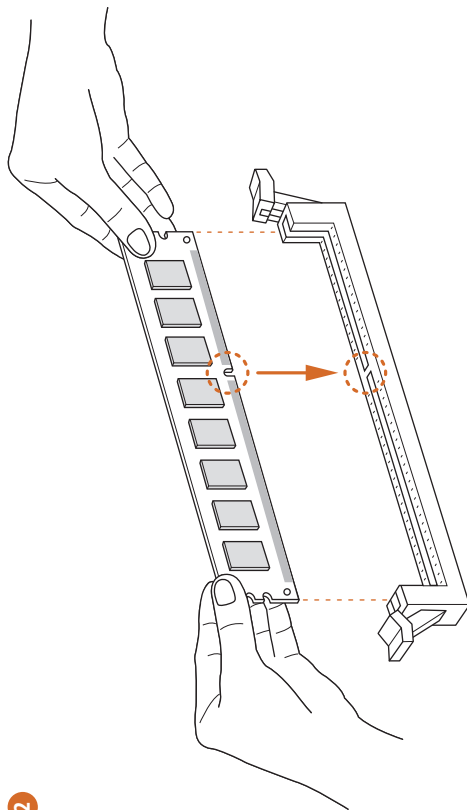

3

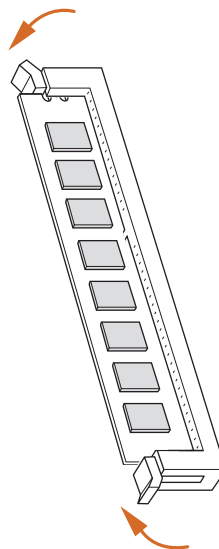

## 2.4 Expansion Slots (PCI Express Slots)

There are 5 PCI Express slots on the motherboard.



*Before installing an expansion card, please make sure that the power supply is switched off or the power cord is unplugged. Please read the documentation of the expansion card and make necessary hardware settings for the card before you start the installation.*

### PCIe slots:

PCIE1 (PCIe 2.0 x1 slots) is used for PCI Express x1 lane width cards.

PCIE2 (PCIe 2.0 x16 slot) is used for PCI Express x16 lane width graphics cards.

PCIE3 (PCIe 2.0 x16 slot) is used for PCI Express x16 lane width graphics cards.

PCIE4 (PCIe 2.0 x1 slots) is used for PCI Express x1 lane width cards.

PCIE5 (PCIe 2.0 x16 slot) is used for PCI Express x4 lane width graphics cards

### PCIe Slot Configurations

	PCIE2	PCIE3	PCIE5
<b>Single Graphics Card</b>	x16	N/A	N/A
<b>Two Graphics Cards in CrossFireX™ or SLI™ Mode</b>	x16	x16	N/A
<b>Three Graphics Cards in 3-Way CrossFireX™ Mode</b>	x16	x16	x4



*For a better thermal environment, please connect a chassis fan to the motherboard's chassis fan connector (CHA\_FAN1, CHA\_FAN2 or CHA\_FAN3) when using multiple graphics cards.*

## 2.5 Jumpers Setup

The illustration shows how jumpers are setup. When the jumper cap is placed on the pins, the jumper is “Short”. If no jumper cap is placed on the pins, the jumper is “Open”. The illustration shows a 3-pin jumper whose pin1 and pin2 are “Short” when a jumper cap is placed on these 2 pins.

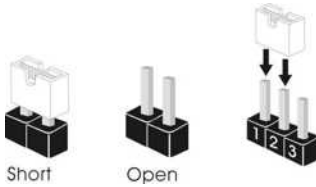

---

Clear CMOS Jumper  
(CLR CMOS1)  
(see p.1, No. 21)

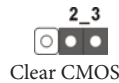

---

CLR CMOS1 allows you to clear the data in CMOS. To clear and reset the system parameters to default setup, please turn off the computer and unplug the power cord from the power supply. After waiting for 15 seconds, use a jumper cap to short pin2 and pin3 on CLR CMOS1 for 5 seconds. However, please do not clear the CMOS right after you update the BIOS. If you need to clear the CMOS when you just finish updating the BIOS, you must boot up the system first, and then shut it down before you do the clear-CMOS action. Please be noted that the password, date, time, and user default profile will be cleared only if the CMOS battery is removed.

## 2.6 Onboard Headers and Connectors



Onboard headers and connectors are NOT jumpers. Do NOT place jumper caps over these headers and connectors. Placing jumper caps over the headers and connectors will cause permanent damage to the motherboard.

System Panel Header  
(9-pin PANEL1)  
(see p.1, No. 20)

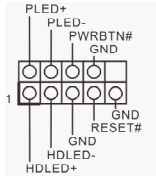

Connect the power switch, reset switch and system status indicator on the chassis to this header according to the pin assignments below. Note the positive and negative pins before connecting the cables.



### **PWRBTN (Power Switch):**

Connect to the power switch on the chassis front panel. You may configure the way to turn off your system using the power switch.

### **RESET (Reset Switch):**

Connect to the reset switch on the chassis front panel. Press the reset switch to restart the computer if the computer freezes and fails to perform a normal restart.

### **PLED (System Power LED):**

Connect to the power status indicator on the chassis front panel. The LED is on when the system is operating. The LED keeps blinking when the system is in S1/S3 sleep state. The LED is off when the system is in S4 sleep state or powered off (S5).

### **HDLED (Hard Drive Activity LED):**

Connect to the hard drive activity LED on the chassis front panel. The LED is on when the hard drive is reading or writing data.

The front panel design may differ by chassis. A front panel module mainly consists of power switch, reset switch, power LED, hard drive activity LED, speaker and etc. When connecting your chassis front panel module to this header, make sure the wire assignments and the pin assignments are matched correctly.

Power LED Header  
 (3-pin PLED1)  
 (see p.1, No. 18)

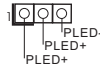

Please connect the chassis power LED to this header to indicate the system's power status.

Serial ATA3 Connectors  
 (SATA3\_1:  
 see p.1, No. 17)  
 (SATA3\_2:  
 see p.1, No. 16)  
 (SATA3\_3:  
 see p.1, No. 14)  
 (SATA3\_4:  
 see p.1, No. 15)  
 (SATA3\_5:  
 see p.1, No. 12)



These five SATA3 connectors support SATA data cables for internal storage devices with up to 6.0 Gb/s data transfer rate.

USB 2.0 Headers  
 (9-pin USB6\_7)  
 (see p.1, No. 9)  
 (9-pin USB8\_9)  
 (see p.1, No. 8)

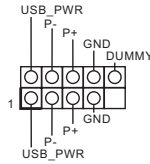

Besides six USB 2.0 ports on the I/O panel, there are two headers on this motherboard. Each USB 2.0 header can support two ports.

USB 3.0 Headers  
 (19-pin USB3\_5\_6)  
 (see p.1, No. 10)

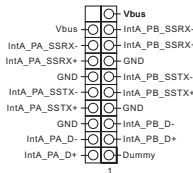

Besides four USB 3.0 ports on the I/O panel, there is one header and one port on this motherboard. Each USB 3.0 header can support two ports.

(USB3\_7)  
 (see p.1, No. 11)



Front Panel Audio Header  
(9-pin HD\_AUDIO1)  
(see p.1, No. 27)

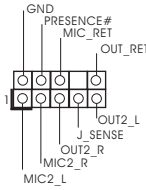

This header is for connecting audio devices to the front audio panel.



1. High Definition Audio supports Jack Sensing, but the panel wire on the chassis must support HDA to function correctly. Please follow the instructions in our manual and chassis manual to install your system.
2. If you use an AC'97 audio panel, please install it to the front panel audio header by the steps below:
  - A. Connect Mic\_IN (MIC) to MIC2\_L.
  - B. Connect Audio\_R (RIN) to OUT2\_R and Audio\_L (LIN) to OUT2\_L.
  - C. Connect Ground (GND) to Ground (GND).
  - D. MIC\_RET and OUT\_RET are for the HD audio panel only. You don't need to connect them for the AC'97 audio panel.
  - E. To activate the front mic, go to the "FrontMic" Tab in the Realtek Control panel and adjust "Recording Volume".

Chassis Speaker Header  
(4-pin SPEAKER1)  
(see p.1, No. 19)

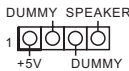

Please connect the chassis speaker to this header.

Chassis and Power Fan Connectors  
(4-pin CHA\_FAN1)  
(see p.1, No. 29)

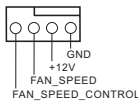

Please connect fan cables to the fan connectors and match the black wire to the ground pin.

(3-pin CHA\_FAN2)  
(see p.1, No. 1)

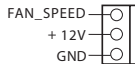

(3-pin CHA\_FAN3)  
(see p.1, No. 22)



(3-pin PWR\_FAN1)  
(see p.1, No. 28)



CPU Fan Connectors  
(4-pin CPU\_FAN1)  
(see p.1, No. 3)

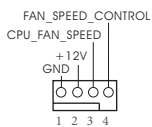

This motherboard provides a 4-Pin CPU fan (Quiet Fan) connector. If you plan to connect a 3-Pin CPU fan, please connect it to Pin 1-3.

(3-pin CPU\_FAN2)  
(see p.1, No. 4)

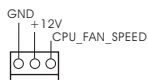

ATX Power Connector  
(24-pin ATXPWR1)  
(see p.1, No. 7)

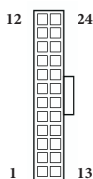

This motherboard provides a 24-pin ATX power connector. To use a 20-pin ATX power supply, please plug it along Pin 1 and Pin 13.

ATX 12V Power Connector  
(8-pin ATX12V1)  
(see p.1, No. 2)

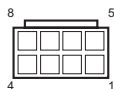

This motherboard provides an 8-pin ATX 12V power connector. To use a 4-pin ATX power supply, please plug it along Pin 1 and Pin 5.

SLI/XFIRE Power Connector  
(4-pin SLI/XFIRE\_PWR1)  
(see p.1, No. 23)



Please connect this connector with a hard disk power connector when three graphics cards are installed on this motherboard.

Infrared Module Header  
(5-pin IR1)  
(see p.1, No. 24)

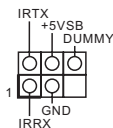

This header supports an optional wireless transmitting and receiving infrared module.

Serial Port Header  
(9-pin COM1)  
(see p.1, No. 25)

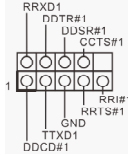

This COM1 header supports a serial port module.

SPDIF Out Connector  
(2-pin SPDIF\_OUT1)  
(see p.1, No. 26)



Please connect the SPDIF\_OUT connector of a HDMI VGA card to this header with a cable.

TPM Header  
(17-pin TPMS1)  
(see p.1, No. 13)

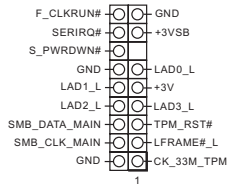

This connector supports Trusted Platform Module (TPM) system, which can securely store keys, digital certificates, passwords, and data. A TPM system also helps enhance network security, protects digital identities, and ensures platform integrity.

# 1 Einleitung

Vielen Dank, dass Sie sich für die FatalIty 990FX Killer Series von ASRock entschieden haben – ein zuverlässiges Motherboard, das konsequent unter der strengen Qualitätskontrolle von ASRock hergestellt wurde. Es liefert ausgezeichnete Leistung mit robustem Design, das ASRocks Streben nach Qualität und Beständigkeit erfüllt.



*Da die technischen Daten des Motherboards sowie die BIOS-Software aktualisiert werden können, kann der Inhalt dieser Anleitung ohne Ankündigung geändert werden. Falls diese Anleitung irgendwelchen Änderungen unterliegt, wird die aktualisierte Version ohne weitere Hinweise auf der ASRock-Webseite zur Verfügung gestellt. Sollten Sie technische Hilfe in Bezug auf dieses Motherboard benötigen, erhalten Sie auf unserer Webseite spezifischen Informationen über das von Ihnen verwendete Modell. Auch finden Sie eine aktuelle Liste unterstützter VGA-Karten und Prozessoren auf der ASRock-Webseite: ASRock-Webseite <http://www.asrock.com>.*

## 1.1 Lieferumfang

- ASRock FatalIty 990FX Killer Series-Motherboard (ATX-Formfaktor)
- ASRock FatalIty 990FX Killer Series-Schnellinstallationsanleitung
- ASRock FatalIty 990FX Killer Series-Support-CD
- 4 x Serial-ATA- (SATA) Datenkabel (optional)
- 1 x E/A-Blendenabschirmung
- 1 x ASRock SLI\_Bridge\_2S-Karte
- 1 x M.2\_SSD- (NGFF) Sockel 3-Schraube

## 1.2 Technische Daten

- Plattform**
- ATX-Formfaktor
  - Premium Gold-Kondensatordesign (100 % in Japan gefertigt, hochqualitative leitfähige Polymer-Kondensatoren)

- A-Stil**
- Purity Sound™

- Gaming Armor**
- CPU-Power**
- Hi-Density-Netzanschluss

**VGA-Karte**

- 15µGold Finger in VGA-PCIe-Steckplatz (PCIE2/PCIE3)
- SLI/XFire-Netzanschluss

**Internet**

- Qualcomm® Atheros® Killer™ LAN

**Audio**

- Purity Sound™

- Prozessor**
- Unterstützung von Socket AM3+-Prozessoren
  - Unterstützung von Socket AM3-Prozessoren: AMD Phenom™ II X6 / X4 / X3 / X2 (außer 920 / 940) / Athlon X4 / X3 / X2 / Sempron-Prozessor
  - Acht-Kern-CPU-bereit
  - Unterstützt UCC (Unlock CPU Core)
  - Digipower-Design
  - Erweitertes 8 + 2-Stromphasendesign
  - Unterstützt CPU bis 140W
  - Unterstützt Cool 'n' Quiet™-Technologie von AMD
  - FSB 2600 MHz (5.2 GT/s)
  - Unterstützt Untied-Übertaktungstechnologie
  - Unterstützt Hyper-Transport- 3.0 Technologie (HT 3.0)

- Chipsatz**
- Northbridge: AMD 990FX
  - Southbridge: AMD SB950

- Speicher**
- Dualkanal-DDR3-Speichertechnologie
  - 4 x DDR3-DIMM-Steckplätze
  - Unterstützt DDR3 2450(OC)/2100(OC)/1600/1333/1066 non-ECC, ungepufferter Speicher (siehe ACHTUNG1)
  - Systemspeicher, max. Kapazität: 64 GB (siehe ACHTUNG2)

- Unterstützt Intel® Extreme Memory Profile (XMP) 1.3/1.2
- Unterstützt AMDs Memory Profile Technology (AMP)

### **Erweiterungssteckplatz**

- 3 x PCI-Express 2.0-x16-Steckplätze (PCI-E2/PCI-E3: x16-Modus; PCI-E5: x4-Modus)
- 2 x PCI-Express 2.0-x1-Steckplätze
- Unterstützt AMD Quad CrossFireX™, 3-Wege-CrossFireX™ und CrossFireX™
- Unterstützt NVIDIA® Quad SLI™ und SLI™

### **Audio**

- 7.1-Kanal-HD-Audio mit Inhaltsschutz (Realtek ALC1150-Audiocodec)
- Erstklassige Blu-ray-Audiounterstützung
- Unterstützt Purity Sound™
  - 115-dB-SRV-DAC mit Differentialverstärker
  - TI® NE5532 (unterstützt erstklassigen Headset-Verstärker mit bis zu 600 Ohm)
  - Direct Drive Technology
  - Abdeckung mit EMV-Abschirmung
  - PCB-isolierte Abschirmung
- Unterstützt DTS Connect

### **LAN**

- PCI-E x1 Gigabit LAN 10/100/1000 Mb/s
- Qualcomm® Atheros® Killer™ E2200 Series
- Unterstützt Wake-On-LAN
- Unterstützt energieeffizientes Ethernet 802.3az
- Unterstützt PXE

### **Rückblende, E/A**

- 1 x PS/2-Mausanschluss
- 1 x PS/2-Tastaturanschluss
- 1 x Optischer SPDIF-Ausgang
- 5 x USB 2.0-Ports
- 1 x FatalIty-Mausanschluss (USB 2.0)
- 4 x USB 3.0-Ports (ASMedia-Hub)
- 1 x eSATA3-Anschluss
- 1 x RJ-45-LAN-Port mit LED (Aktivität/Verbindung-LED und Geschwindigkeit-LED)
- HD-Audioanschluss: Hintere Lautsprecher / Zentral / Bass / Line-in / Vorderer Lautsprecher / Mikrofon

**Speicher**

- 5 x SATA-III-6,0-Gb/s-Anschlüsse, unterstützt RAID (RAID 0, RAID 1, RAID 0+1, JBOD und RAID 5), NCQ, AHCI und „Hot-Plugging“
- 1 x M.2\_SSD- (NGFF) Sockel 3, unterstützt M.2-SATA3-6,0-Gb/s-Modul und M.2-PCI-Express-Modul bis Gen2 x2 (10-Gb/s) (M.2\_SSD- (NGFF) Sockel 3 wird mit dem eSATA3-Anschluss geteilt)

**Anschluss**

- 1 x IR-Stiftleiste
- 1 x COM-Anschluss-Stiftleiste
- 1 x TPM-Stiftleiste
- 1 x Betrieb-LED-Stiftleiste
- 2 x CPU-Lüfteranschlüsse (1 x 4-polig, 1 x 3-polig)
- 3 x Gehäuselüfteranschlüsse (1 x 4-polig, 2 x 3-polig)
- 1 x Netzteil Lüfteranschluss (3-polig)
- 1 x 24-poliger ATX-Netzanschluss
- 1 x 8-poliger 12-V-Netzanschluss (hochdichter Netzanschluss)
- 1 x SLI/XFire-Netzanschluss
- 1 x Audioanschluss an Frontblende
- 1 x SPDIF-Ausgang
- 2 x USB 2.0-Stiftleisten (unterstützt vier USB 2.0-Ports)
- 1 x Vertikal, Typ A, USB 3.0
- 1 x Etron EJ188 USB 3.0-Stiftleiste (unterstützt zwei USB 3.0-Ports)

**BIOS-Funktion**

- 32-Mb-AMI-UEFI-Legal-BIOS mit Unterstützung grafischer Benutzerschnittstellen
- Unterstützung für „Plug and Play“
- ACPI 1.1-konforme Aufweckereignisse
- JumperFree-Modus
- SMBIOS 2.3.1-Unterstützung
- CPU, DRAM, NB, HT, CPU VDDA, PCIE VDDA, CPU NB / Mehrfachspannungsanpassung

**Support-CD**

- Treiber, Dienstprogramme, Antivirensoftware (Testversion), Google Chrome Browser und Toolbar, Start8 (30-Tage-Testversion), XSplit, Killer Network Manager

**Hardware-  
überwa-  
chung**

- CPU-/Gehäusetemperaturerkennung
- CPU/Gehäuse/Netzteil-Lüfertachometer
- Lautloser CPU-/Gehäuselüfter (ermöglicht automatische Anpassung der Geschwindigkeit des Gehäuselüfters über die CPU-Temperatur)
- CPU/Gehäuselüfter-Mehrfachgeschwindigkeitssteuerung
- Spannungsüberwachung: +12 V, +5 V, +3,3 V, CPU Vcore

**Betriebssy-  
stem**

- Konform mit Microsoft® Windows® 10, 64 Bit / 8.1, 32 Bit / 8.1, 64 Bit / 8, 32 Bit / 8, 64 Bit / 7, 32 Bit / 7, 64 Bit

**Zertifizie-  
rungen**

- FCC, CE, WHQL
- ErP/EuP ready (ErP/EuP ready-Netzteil erforderlich)

\* Detaillierte Produktinformationen finden Sie auf unserer Webseite: <http://www.asrock.com>



Bitte beachten Sie, dass mit einer Übertaktung, zu der die Anpassung von BIOS-Einstellungen, die Anwendung der Untied Overclocking Technology oder die Nutzung von Übertaktungswerkzeugen von Drittanbietern zählen, bestimmte Risiken verbunden sind. Eine Übertaktung kann sich auf die Stabilität Ihres Systems auswirken und sogar Komponenten und Geräte Ihres Systems beschädigen. Sie sollte auf eigene Gefahr und eigene Kosten durchgeführt werden. Wir übernehmen keine Verantwortung für mögliche Schäden, die durch eine Übertaktung verursacht wurden.



1. Ob die Speichergeschwindigkeit 2450/2100 MHz unterstützt wird, hängt von der von Ihnen eingesetzten AM3/AM3+-CPU ab. Schauen Sie bitte auf unseren Internetseiten in der Liste mit unterstützten Speichermodulen nach, wenn Sie DDR3 2450/2100-Speichermodule einsetzen möchten.  
ASRock-Internetseite: <http://www.asrock.com>
2. Durch Betriebssystem-Einschränkungen kann die tatsächliche Speichergröße weniger als 4 GB betragen, da unter Windows® 8 / 7 etwas Speicher zur Nutzung durch das System reserviert wird. Unter Windows® OS mit 64-Bit-CPU besteht diese Einschränkung nicht. Mit ASRock XFast RAM können Sie den Speicher einsetzen, den Windows® nicht nutzen kann.

## 1.3 Jumper-Einstellung

Die Abbildung zeigt, wie die Jumper eingestellt werden. Wenn die Jumper-Kappe auf den Kontakten angebracht ist, ist der Jumper „kurzgeschlossen“. Wenn keine Jumper-Kappe auf den Kontakten angebracht ist, ist der Jumper „offen“. Die Abbildung zeigt einen 3-poligen Jumper, dessen Kontakt 1 und Kontakt 2 „kurzgeschlossen“ sind, wenn eine Jumper-Kappe auf diesen 2 Kontakten angebracht ist.

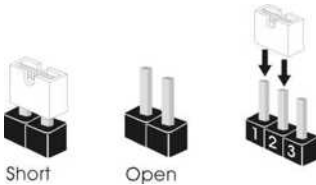

---

CMOS-löschen-Jumper  
(CLRCMOS1)  
(siehe S. 1, Nr. 21)



---

CLRCMOS1 ermöglicht Ihnen die Löschung der Daten im CMOS. Zum Löschen und Zurücksetzen der Systemparameter auf die Standardeinrichtung schalten Sie den Computer bitte ab und ziehen das Netzkabel aus der Steckdose. Warten Sie 15 Sekunde, schließen Sie dann Kontakt 2 und Kontakt 3 an CLRCMOS1 5 Sekunden lang mit einer Jumper-Kappe kurz. Löschen Sie den CMOS jedoch nicht direkt nach der BIOS-Aktualisierung. Falls Sie den CMOS direkt nach Abschluss der BIOS-Aktualisierung löschen müssen, starten Sie das System zunächst; fahren Sie es dann vor der CMOS-Löschung herunter. Bitte beachten Sie, dass Kennwort, Datum, Zeit und Benutzerstandardprofil nur gelöscht werden, wenn die CMOS-Batterie entfernt wird.

## 1.4 Integrierte Stiftleisten und Anschlüsse



*Integrierte Stiftleisten und Anschlüsse sind KEINE Jumper. Bringen Sie KEINE Jumper-Kappen an diesen Stiftleisten und Anschlüssen an. Durch Anbringen von Jumper-Kappen an diesen Stiftleisten und Anschlüssen können Sie das Motherboard dauerhaft beschädigen.*

Systemblende-Stiftleiste  
(9-polig, PANEL1)  
(siehe S. 1, Nr. 20)

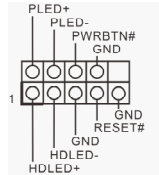

Verbinden Sie Netzschalter, Reset-Taste und Systemstatusanzeige am Gehäuse entsprechend der nachstehenden Pinbelegung mit dieser Stiftleiste. Beachten Sie vor Anschließen der Kabel die positiven und negativen Kontakte.



**PWRBTN (Ein-/Austaste):**

Mit der Ein-/Austaste an der Frontblende des Gehäuses verbinden. Sie können die Abschaltung Ihres Systems über die Ein-/Austaste konfigurieren.

**RESET (Reset-Taste):**

Mit der Reset-Taste an der Frontblende des Gehäuses verbinden. Starten Sie den Computer über die Reset-Taste neu, wenn er abstürzt oder sich nicht normal neu starten lässt.

**PLED (Systembetrieb-LED):**

Mit der Betriebsstatusanzeige an der Frontblende des Gehäuses verbinden. Die LED leuchtet, wenn das System läuft. Die LED blinkt, wenn sich das System im S1/S3-Ruhezustand befindet. Die LED ist aus, wenn sich das System im S4-Ruhezustand befindet oder ausgeschaltet ist (S5).

**HDLED (Festplattenaktivität-LED):**

Mit der Festplattenaktivität-LED an der Frontblende des Gehäuses verbinden. Die LED leuchtet, wenn die Festplatte Daten liest oder schreibt.

Das Design der Frontblende kann je nach Gehäuse variieren. Ein Frontblendenmodul besteht hauptsächlich aus Ein-/Austaste, Reset-Taste, Betrieb-LED, Festplattenaktivität-LED, Lautsprecher etc. Stellen Sie beim Anschließen Ihres Frontblendenmoduls an diese Stiftleiste sicher, dass Kabel- und Pinbelegung richtig abgestimmt sind.

Betrieb-LED-Stiftleiste  
(3-polig, PLED1)  
(siehe S. 1, Nr. 18)



Bitte verbinden Sie die Betrieb-LED des Gehäuses zur Anzeige des Systembetriebsstatus mit dieser Stiftleiste.

Serial-ATA-III-Anschlüsse  
(SATA3\_1: siehe S. 1, Nr. 17)  
(SATA3\_2: siehe S. 1, Nr. 16)  
(SATA3\_3: siehe S. 1, Nr. 14)  
(SATA3\_4: siehe S. 1, Nr. 15)  
(SATA3\_5: siehe S. 1, Nr. 12)

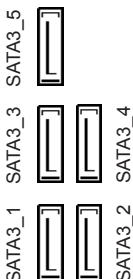

Diese fünf SATA-III-Anschlüsse unterstützen SATA-Datenkabel für interne Speichergeräte mit einer Datenübertragungsgeschwindigkeit bis 6,0 Gb/s.

USB 2.0-Stiftleisten  
(9-polig, USB6\_7)  
(siehe S. 1, Nr. 9)  
(9-polig, USB8\_9)  
(siehe S. 1, Nr. 8)

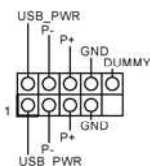

Neben sechs USB 2.0-Ports an der E/A-Blende befinden sich zwei Stiftleisten an diesem Motherboard. Jede USB 2.0-Stiftleiste kann zwei Ports unterstützen.

USB 3,0-Stiftleisten  
(19-polig, USB3\_5\_6)  
(siehe S. 1, Nr. 10)

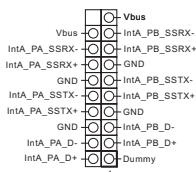

Neben vier USB 3.0-Ports an der E/A-Blende befinden sich eine Steckleiste und ein Port an diesem Motherboard. Jede USB 3.0-Stiftleiste kann zwei Ports unterstützen.

(USB3\_7)  
(siehe S. 1, Nr. 11)



**Audiostiftleiste**  
(Frontblende)  
(9-polig, HD\_AUDIO1)  
(siehe S. 1, Nr. 27)

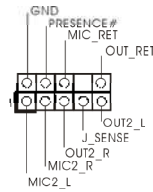

Diese Stiftleiste dient dem Anschließen von Audiogeräten an der Frontblende.



1. High Definition Audio unterstützt Anschlusserkennung, der Draht am Gehäuse muss dazu jedoch HDA unterstützt. Bitte befolgen Sie zum Installieren Ihres Systems die Anweisungen in unserer Anleitung und der Anleitung zum Gehäuse.
2. Wenn Sie ein AC'97-Audiopanel nutzen, installieren Sie es bitte anhand der nachstehenden Schritte an der Audiostiftleiste (Frontblende):
  - A. Verbinden Sie Mic\_IN (MIC) mit MIC2\_L.
  - B. Verbinden Sie Audio\_R (RIN) mit OUT2\_R und Audio\_L (LIN) mit OUT2\_L.
  - C. Verbinden Sie Erde (GND) mit Erde (GND).
  - D. MIC\_RET und OUT\_RET sind nur für das HD-Audio-Panel vorgesehen. Sie müssen Sie nicht mit dem AC'97-Audiopanel verbinden.
  - E. Rufen Sie zur Aktivierung des vorderen Mikrofons das „FrontMic (Frontmikrofon)“-Register in der Realtek-Systemsteuerung auf und passen „Recording Volume (Aufnahmelautstärke)“ an.

**Gehäuselautsprecherstiftleiste**  
(4-polig, SPEAKER1)  
(siehe S. 1, Nr. 19)

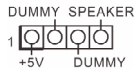

Bitte verbinden Sie den Gehäuselautsprecher mit dieser Stiftleiste.

**Gehäuse- und Netzteil Lüfteranschlüsse**  
(4-polig, CHA\_FAN1)  
(siehe S. 1, Nr. 29)

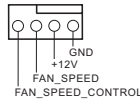

Bitte verbinden Sie die Lüfterkabel mit den Lüfteranschlüssen; der schwarze Draht gehört zum Erdungskontakt.

(3-polig, CHA\_FAN2)  
(siehe S. 1, Nr. 1)

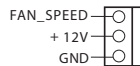

(3-polig, CHA\_FAN3)  
(siehe S. 1, Nr. 22)



(3-polig, PWR\_FAN1)  
(siehe S. 1, Nr. 28)



CPU-Lüfteranschlüsse  
(4-polig, CPU\_FAN1)  
(siehe S. 1, Nr. 3)

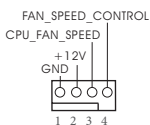

(3-polig, CPU\_FAN2)  
(siehe S. 1, Nr. 4)

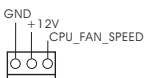

Dieses Motherboard bietet einen 4-poligen CPU-Lüfteranschluss (lautloser Lüfter). Falls Sie einen 3-poligen CPU-Lüfter anschließen möchten, verbinden Sie ihn bitte mit Kontakt 1 bis 3.

ATX-Netzanschluss  
(24-polig, ATXPWR1)  
(siehe S. 1, Nr. 7)

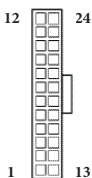

Dieses Motherboard bietet einen 24-poligen ATX-Netzanschluss. Bitte schließen Sie es zur Nutzung eines 20-poligen ATX-Netzteils entlang Kontakt 1 und Kontakt 13 an.

ATX-12-V-Netzanschluss  
(8-polig, ATX12V1)  
(siehe S. 1, Nr. 2)

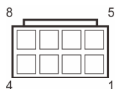

Dieses Motherboard bietet einen 8-poligen ATX-12-V-Netzanschluss. Bitte schließen Sie es zur Nutzung eines 4-poligen ATX-Netzteils entlang Kontakt 1 und Kontakt 5 an.

SLI/XFIRE-  
Netzanschluss  
(4-polig, SLI/XFIRE\_  
PWR1)  
(siehe S. 1, Nr. 23)



Bitte verbinden Sie diese Anschluss mit einem Festplattennetzanschluss, wenn drei Grafikkarten an diesem Motherboard installiert sind.

Infrarotmodul-Stiftleiste  
(5-polig, IR1)  
(siehe S. 1, Nr. 24)

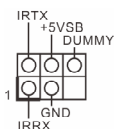

Diese Stiftleiste unterstützt ein optionales kabelloses Infrarotmodul zum Übertragen und Empfangen.

Serieller-Port-Stiftleiste  
(9-polig, COM1)  
(siehe S. 1, Nr. 25)

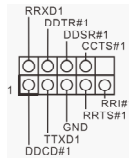

Diese COM1-Stiftleiste unterstützt ein Modul für serielle Ports.

SPDIF-Ausgang  
(2-polig, SPDIF\_OUT1)  
(siehe S. 1, Nr. 26)



Bitte verbinden Sie den SPDIF\_OUT-Anschluss einer HDMI-VGA-Karte über ein Kabel mit dieser Stiftleiste.

TPM-Stiftleiste  
(17-polig, TPMS1)  
(siehe S. 1, Nr. 13)

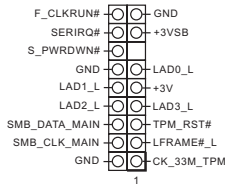

Dieser Anschluss unterstützt das Trusted Platform Module- (TPM) System, das Schlüssel, digitale Zertifikate, Kennwörter und Daten sicher aufbewahren kann. Ein TPM-System hilft zudem bei der Stärkung der Netzwerksicherheit, schützt digitale Identitäten und gewährleistet die Plattformintegrität.

# 1 Introduction

Nous vous remercions d'avoir acheté cette carte mère ASRock de la série Fatal1ty 990FX Killer, une carte mère fiable fabriquée conformément au contrôle de qualité rigoureux et constant appliqué par ASRock. Elle vous offre de performances élevées associées à une conception robuste, dignes de l'engagement de qualité et de durabilité qui font la réputation de ASRock.



*Les spécifications de la carte mère et du logiciel BIOS pouvant être mises à jour, le contenu de ce document est soumis à modification sans préavis. En cas de modifications du présent document, la version mise à jour sera disponible sur le site Internet ASRock sans notification préalable. Si vous avez besoin d'une assistance technique pour votre carte mère, veuillez visiter notre site Internet pour plus de détails sur le modèle que vous utilisez. La liste la plus récente des cartes VGA et des processeurs pris en charge est également disponible sur le site Internet de ASRock. Site Internet ASRock <http://www.asrock.com>.*

## 1.1 Contenu de l'emballage

- Carte mère ASRock Série Fatal1ty 990FX Killer (facteur de forme ATX)
- Guide d'installation rapide ASRock Série Fatal1ty 990FX Killer
- CD d'assistance ASRock Série Fatal1ty 990FX Killer
- 4 x câbles de données Serial ATA (SATA) (Optionnel)
- 1 x panneau de protection E/S
- 1 x carte ASRock SLI\_Bridge\_2S
- 1 x M.2\_SSD (NGFF) Socket 3 Vis

## 1.2 Spécifications

- Plateforme**
- Facteur de forme ATX
  - Condensateur de conception premium or (condensateurs haute qualité en polymère conducteur 100% fabriqués au Japon)

- A-Style**
- Purity Sound™

- Armure gaming**
- Alimentation du processeur**
- Connecteur d'alimentation haute densité

**Carte VGA**

- Gold Finger 15µ dans fente VGA PCIe (PCIE2/PCIE3)
- Connecteur d'alimentation SLI/XFire

**Internet**

- Qualcomm® Atheros® Killer™ LAN

**Audio**

- Purity Sound™

- Processeur**
- Prise en charge des processeurs sur socket AM3+
  - Prise en charge des processeurs sur socket AM3: Processeur Phenom™ II X6 / X4 / X3 / X2 (sauf 920 / 940) / Athlon II X4 / X3 / X2 / Sempron d'AMD
  - Prêt pour processeurs Huit-Core
  - Supporte UCC (Unlock CPU Core)
  - Conception Digi Power
  - Conception 8 + 2 Power Phase
  - Supporte les processeurs jusqu'à 140W
  - Supporte la technologie Cool 'n' Quiet™ d'AMD
  - FSB 2600 MHz (5.2 GT/s)
  - Prend en charge la technologie Untied Overclocking
  - Prise en charge de la technologie Hyper Transport 3.0 (HT 3.0)

- Chipset**
- Northbridge: AMD 990FX
  - Southbridge: AMD SB950

- Mémoire**
- Technologie mémoire double canal DDR3
  - 4 x fentes DIMM DDR3
  - Prend en charge les mémoires sans tampon non ECC DDR3 2450(OC)/2100(OC)/1600/1333/1066 (voir AVERTISSEMENT1)
  - Capacité max. de la mémoire système : 64Go (voir AVERTISSEMENT2)

- Prend en charge Intel® Extreme Memory Profile (XMP)1.3/1.2
- Prend en charge la technologie AMD Memory Profile (Profil de mémoire AMD - AMP)

### Fente d'expansion

- 3 x fentes PCI Express 2.0 x16 (PCIE2/PCIE3: mode x16; PCIE5: mode x4)
- 2 x fente PCI Express 2.0 x1
- Prend en charge AMD Quad CrossFireX™, 3-Way CrossFireX™ et CrossFireX™
- Prend en charge NVIDIA® Quad SLI™ et SLI™

### Audio

- Audio 7.1 CH HD avec protection du contenu (codec audio Realtek ALC1150)
- Compatible audio Blu-ray Premium
- Prend en charge Purity Sound™
  - 115dB SNR DAC avec amplificateur différentiel
  - TI® NE5532 (compatible Premium Headset Amplifier jusqu'à 600 Ohms)
  - technologie Direct Drive
  - capot de protection EMI
  - blindage isolant PCB
- Prend en charge DTS Connect

### Réseau

- PCIE x1 Gigabit LAN 10/100/1000 Mb/s
- Qualcomm® Atheros® Killer™ E2200 Série
- Prend en charge la fonction Wake-On-LAN
- Prend en charge la fonction d'économie d'énergie Ethernet 802,3az
- Prend en charge PXE

### Connectique du panneau arrière

- 1 x port souris PS/2
- 1 x port clavier PS/2
- 1 x port sortie optique SPDIF
- 5 x ports USB 2.0
- 1 x port souris Fatal1ty (USB 2.0)
- 4 x ports USB 3.0 (concentrateur ASMedia)
- 1 x connecteur eSATA3
- 1 x port RJ-45 LAN avec LED (LED ACT/LIEN et LED VITESSE)
- Connecteurs jack audio HD : Haut-parleur arrière / central / basses / entrée ligne / haut-parleur avant / microphone

**Stockage**

- 5 x connecteurs SATA3 6,0 Go/s, compatibles RAID (RAID 0, RAID 1, RAID 0+1, JBOD et RAID 5), NCQ, AHCI et « Hot Plug »
- 1 x M.2\_SSD (NGFF) Socket 3, prend en charge le module M.2 SATA3 6,0 Go/s et le module M.2 PCI Express jusqu'à Gen2 x2 (10 Go/s) (M.2\_SSD (NGFF) Socket 3 est partagé avec le connecteur eSATA3)

**Connec-  
tique**

- 1 x embase IR
- 1 x embase pour port COM
- 1 x embase TPM
- 1 x embase LED d'alimentation
- 2 x connecteurs pour ventilateur de processeur (1 x 4 broches, 1 x 3 broches)
- 3 x connecteurs pour ventilateur de châssis (1 x 4 broches, 2 x 3 broches)
- 1 x connecteur pour ventilateur d'alimentation (3 broches)
- 1 x connecteur d'alimentation ATX 24 broches
- 1 x connecteur d'alimentation 12V 8 broches (connecteur d'alimentation haute densité)
- 1 x connecteur d'alimentation SLI/XFire
- 1 x connecteur audio panneau frontal
- 1 x port sortie SPDIF
- 2 x embases USB 2.0 (pour 4 ports USB 2.0)
- 1 x port USB 3.0 type A vertical
- 1 x embase Etron EJ188 USB 3.0 (pour 2 ports USB 3.0)

**Caractéris-  
tiques du  
BIOS**

- BIOS UEFI AMI 32Mo avec prise en charge interface graphique
- Support du "Plug and Play"
- Compatible ACPI 1.1 Wake Up Events
- Gestion jumperless
- Prend en charge SMBIOS 2.3.1
- Réglage de la tension CPU, DRAM, NB, HT, CPU VDDA, PCIE VDDA, CPU NB

**CD inclus**

- Pilotes, utilitaires, logiciel AntiVirus (version d'évaluation), navigateur Google Chrome et barre d'outils, Start8 (30 jours d'évaluation), XSplit, Killer Network Manager

**Surveillance  
du matériel**

- Détection de la température du processeur/châssis
- Tachéomètre processeur/châssis/ventilateur d'alimentation
- Fonction ventilateur silencieux processeur/châssis Quiet Fan (permet au ventilateur du châssis d'adapter sa vitesse de rotation automatiquement en fonction de la température du processeur)
- Contrôle simultané des vitesse du ventilateur processeur/châssis
- Surveillance de la tension d'alimentation : +12V, +5V, +3,3V, CPU Vcore

**Système  
d'exploita-  
tion**

- Compatible Microsoft® Windows® 10 64-bit / 8.1 32-bit / 8.1 64-bit / 8 32-bit / 8 64-bit / 7 32-bit / 7 64-bits

**Certifica-  
tions**

- FCC, CE, WHQL
- ErP/EuP Ready (alimentation ErP/EuP ready requise)

\* pour des informations détaillées de nos produits, veuillez visiter notre site : <http://www.asrock.com>



*Il est important de signaler que l'overclocking présente certains risques, incluant des modifications du BIOS, l'application d'une technologie d'overclocking déliée et l'utilisation d'outils d'overclocking développés par des tiers. La stabilité de votre système peut être affectée par ces pratiques, voire provoquer des dommages aux composants et aux périphériques du système. L'overclocking se fait à vos risques et périls. Nous ne pourrions en aucun cas être tenus pour responsables des dommages éventuels provoqués par l'overclocking.*



- 1. La prise en charge de fréquences de mémoire de 2450/2100MHz dépend du CPU AM3/AM3+ que vous choisissez. Si vous choisissez des barrettes de mémoire DDR3 2450/2100 sur cette carte mère, veuillez vous référer à la liste des mémoires prises en charge sur notre site Web pour connaître barrettes de mémoire compatibles. Site Web ASRock : <http://www.asrock.com>*
- 2. Du fait des limites du système d'exploitation, la taille mémoire réelle réservée au système pourra être inférieure à 4 Go sous Windows® 8 /7. Avec Windows® OS avec CPU 64 bits, il n'y a pas ce genre de limitation. Vous pouvez utiliser ASRock XFast RAM pour utiliser la mémoire dont Windows® ne peut se servir.*

## 1.3 Configuration des cavaliers (jumpers)

L'illustration ci-dessous vous renseigne sur la configuration des cavaliers (jumpers). Lorsque le capuchon du cavalier est installé sur les broches, le cavalier est 'court-circuité'. Si le capuchon du cavalier n'est pas installé sur les broches, le cavalier est 'ouvert'. L'illustration représente un cavalier à 3 broches dont les broches 1 et 2 sont « court-circuitées » si un capuchon de cavalier est posé sur ces 2 broches.

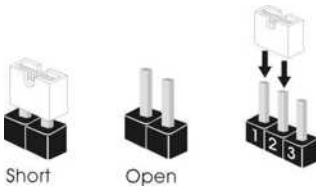

---

Cavalier Clear CMOS  
(CLRCMOS1)  
(voir p.1, No. 21)

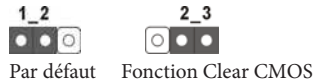

---

CLRCMOS1 vous permet d'effacer les données de la CMOS. Pour effacer les paramètres du système et rétablir les valeurs par défaut, veuillez éteindre votre ordinateur et débrancher son cordon d'alimentation. Patientez 15 secondes, puis utilisez un capuchon de cavalier pour court-circuiter la broche 2 et la broche 3 sur CLRCMOS1 pendant 5 secondes. Toutefois, n'effacez pas la CMOS immédiatement après avoir mis à jour le BIOS. Si vous avez besoin d'effacer les données CMOS après une mise à jour du BIOS, vous devez tout d'abord redémarrer le système, puis l'éteindre avant de procéder à l'effacement de la CMOS. Veuillez noter que les paramètres mot de passe, date, heure et profil par défaut de l'utilisateur seront uniquement effacés en cas de retrait de la pile de la CMOS.

## 1.4 Embases et connecteurs de la carte mère



Les embases et connecteurs situés sur la carte NE SONT PAS des cavaliers. Ne placez JAMAIS de capuchons de cavaliers sur ces embases ou connecteurs. Placer un capuchon de cavalier sur ces embases ou connecteurs endommagera irrémédiablement votre carte mère.

Embase du panneau système  
(PANNEAU1 à 9 broches)  
(voir p.1, No. 20)

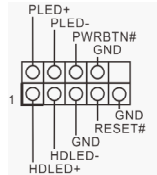

Branchez le bouton de mise en marche/arrêt, le bouton de réinitialisation et le témoin d'état du système présents sur le châssis sur cette embase en respectant la configuration des broches illustrée ci-dessous. Repérez les broches positive et négative avant de brancher les câbles.



**PWRBTN (Bouton de mise en marche) :**  
pour brancher le bouton de mise en marche au panneau frontal du châssis. Vous pouvez configurer la façon dont votre système doit s'arrêter à l'aide du bouton de mise en marche.

**RESET (Bouton de réinitialisation) :**  
pour brancher le bouton de réinitialisation au panneau frontal du châssis. Appuyez sur le bouton de réinitialisation pour redémarrer l'ordinateur en cas de plantage ou de dysfonctionnement au démarrage.

**PLED (LED d'alimentation du système) :**  
pour brancher le témoin d'état de l'alimentation au panneau frontal du châssis. Le LED est allumé lorsque le système fonctionne. Le LED clignote lorsque le système se trouve en mode veille S1/S3. Le LED est éteint lorsque le système se trouve en mode veille S4 ou hors tension (S5).

**HDLED (LED d'activité du disque dur) :**  
pour brancher le témoin LED d'activité du disque dur au panneau frontal du châssis. Le LED est allumé lorsque le disque dur lit ou écrit des données.

La conception du panneau frontal peut varier en fonction du châssis. Un module de panneau frontal est principalement composé d'un bouton de mise en marche, bouton de réinitialisation, LED d'alimentation, LED d'activité du disque dur, haut-parleur etc. Lorsque vous reliez le module du panneau frontal de votre châssis sur cette embase, veillez à parfaitement faire correspondre les fils et les broches.

Embase LED  
d'alimentation  
(PLED1 à 3 broches)  
(voir p.1, No. 18)



Veillez brancher le LED d'alimentation du châssis sur cette embase pour indiquer l'état d'alimentation du système.

Connecteurs Serial ATA3  
(SATA3\_1:  
(voir p.1, No. 17)  
(SATA3\_2:  
(voir p.1, No. 16)  
(SATA3\_3:  
voir p.1, No. 14)  
(SATA3\_4:  
voir p.1, No. 15)  
(SATA3\_5:  
voir p.1, No. 12)

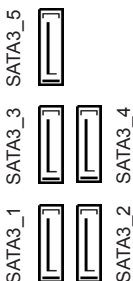

Ces cinq connecteurs SATA3 sont compatibles avec les câbles de données SATA pour les appareils de stockage internes avec un taux de transfert maximal de 6,0 Go/s.

Embases USB 2.0  
(USB6\_7 à 9 broches)  
(voir p.1, No. 9)  
(USB8\_9 à 9 broches)  
(voir p.1, No. 8)

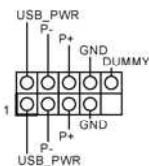

En plus des six ports USB 2.0 sur le panneau E/S, cette carte mère est dotée de deux embases. Chaque embase USB 2.0 peut prendre en charge deux ports.

Embases USB 3.0  
(USB3\_5\_6 à 19 broches)  
(voir p.1, No. 10)

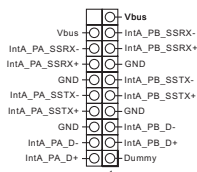

En plus des quatre ports USB 3.0 sur le panneau E/S, cette carte mère est dotée d'une embase et d'un port. Chaque embase USB 3.0 peut prendre en charge deux ports.

(USB3\_7)  
(voir p.1, No. 11)



Embase audio du panneau frontal  
(HD\_AUDIO1 à 9 broches)  
(voir p.1, No. 27)

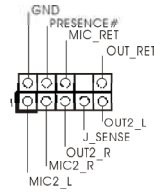

Cette embase sert au branchement des appareils audio au panneau audio frontal.



- L'audio haute définition prend en charge la technologie Jack Sensing (détection de la fiche), mais le panneau grillagé du châssis doit être compatible avec la HDA pour fonctionner correctement. Veuillez suivre les instructions figurant dans notre manuel et dans le manuel du châssis pour installer votre système.
- Si vous utilisez un panneau audio AC'97, veuillez le brancher sur l'embase audio du panneau frontal en procédant comme suit :
  - branchez Mic\_IN (MIC) sur MIC2\_L.
  - branchez Audio\_R (RIN) sur OUT2\_R et Audio\_L (LIN) sur OUT2\_L.
  - branchez la mise à terre (GND) sur mise à terre (GND).
  - MIC\_RET et OUT\_RET sont exclusivement réservés au panneau audio HD. Il est inutile de les brancher avec le panneau audio AC'97.
  - Pour activer le micro frontal, sélectionnez l'onglet « FrontMic » du panneau de contrôle Realtek et réglez le paramètre « Volume d'enregistrement ».

Embase du haut-parleur du châssis  
(SPEAKER1 à 4 broches)  
(voir p.1, No. 19)

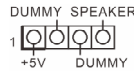

Veillez brancher le haut-parleur du châssis sur cette embase.

Connecteurs du châssis et de l'alimentation du ventilateur  
(CHA\_FAN1 à 4 broches)  
(voir p.1, No. 29)

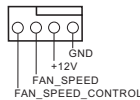

Veillez brancher les câbles du ventilateur sur les connecteurs du ventilateur, puis reliez le fil noir à la broche de mise à terre.

(CHA\_FAN2 à 3 broches)  
(voir p.1, No. 1)

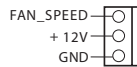

(CHA\_FAN3 à 3 broches)  
(voir p.1, No. 22)



(PWR\_FAN1 à 3 broches)  
(voir p.1, No. 28)



Connecteurs du ventilateur du processeur (CPU\_FAN1 à 4 broches) (voir p.1, No. 3)

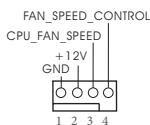

(CPU\_FAN2 à 3 broches) (voir p.1, No. 4)

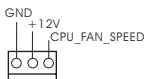

Cette carte mère est dotée d'un connecteur à 4 broches pour ventilateur de processeur (Quiet Fan). Si vous envisagez de connecter un ventilateur de processeur à 3 broches, veuillez le brancher sur la Broche 1-3.

Connecteur d'alimentation ATX (ATXPWR1 à 24 broches) (voir p.1, No. 7)

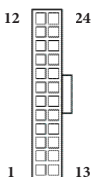

Cette carte mère est dotée d'un connecteur d'alimentation ATX à 24 broches. Pour utiliser une alimentation ATX à 20 broches, veuillez effectuer les branchements sur la Broche 1 et la Broche 13.

Connecteur d'alimentation ATX 12V (ATX12V1 à 8 broches) (voir p.1, No. 2)

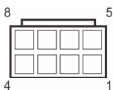

Cette carte mère est dotée d'un connecteur d'alimentation ATX 12V à 8 broches. Pour utiliser une alimentation ATX à 4 broches, veuillez effectuer les branchements sur la Broche 1 et la Broche 5.

Connecteur d'alimentation SLI/XFire (SLI/XFIRE\_PWR1 à 4 broches) (voir p.1, No. 23)



Veillez brancher ce connecteur avec un connecteur d'alimentation de disque dur lorsque trois cartes graphiques sont installées sur la carte mère.

Embase pour module infrarouge (IR1 à 5 broches) (voir p.1, No. 24)

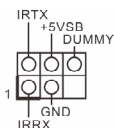

Cette embase prend en charge un module sans-fil d'émission et de réception infrarouge optionnel.

Embase pour port série  
(COM1 à 9 broches)  
(voir p.1, No. 25)

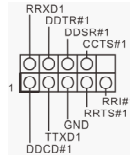

Cette embase COM1 prend en charge un module de port série.

Connecteur sortie SPDIF  
(SPDIF\_OUT1 à 2 broches)  
(voir p.1, No. 26)



Veillez brancher le connecteur SPDIF\_OUT d'une carte VGA HDMI sur cette embase à l'aide d'un câble.

Embase TPM  
(TPMS1 à 17 broches)  
(voir p.1, No. 13)

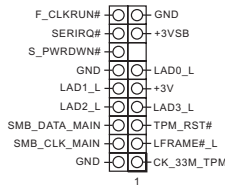

Ce connecteur prend en charge un module TPM (Trusted Platform Module – Module de plateforme sécurisée), qui permet de sauvegarder clés, certificats numériques, mots de passe et données en toute sécurité. Le système TPM permet également de renforcer la sécurité du réseau, de protéger les identités numériques et de préserver l'intégrité de la plateforme.

# 1 Introduzione

Grazie per aver acquistato la scheda madre serie Fatal1ty 990FX Killer ASRock, una scheda madre affidabile prodotta secondo i costanti e rigorosi controlli di qualità di ASRock. La scheda madre offre eccellenti prestazioni con un design robusto che si adatta all'impegno di ASRock di offrire sempre qualità e durata.



*Dato che le specifiche della scheda madre e del software BIOS possono essere aggiornate, il contenuto di questo manuale sarà soggetto a variazioni senza preavviso. Nel caso di eventuali modifiche del presente manuale, la versione aggiornata sarà disponibile sul sito Web di ASRock senza ulteriore preavviso. Per il supporto tecnico correlato a questa scheda madre, visitare il nostro sito Web per informazioni specifiche relative al modello attualmente in uso. È possibile trovare l'elenco di schede VGA più recenti e di supporto di CPU anche sul sito Web di ASRock. Sito Web di ASRock <http://www.asrock.com>.*

## 1.1 Contenuto della confezione

- Scheda madre serie Fatal1ty 990FX Killer ASRock (fattore di forma ATX)
- Guida rapida di installazione serie Fatal1ty 990FX Killer ASRock
- CD di supporto serie Fatal1ty 990FX Killer ASRock
- 4 x cavi dati Serial ATA (SATA) (opzionali)
- 1 x mascherina metallica posteriore I/O
- 1 x scheda ASRock SLI\_Bridge\_2S
- 1 x vite M.2\_SSD (NGFF) Socket 3

## 1.2 Specifiche

### Piattaforma

- Fattore di forma ATX
- Design condensatore Premium Gold (condensatori a conduttore in polimero di alta qualità realizzati al 100% in Giappone)

### Stile superiore

- Purity Sound™

### Armatura da gioco

#### Potenza CPU

- Connettore alimentazione ad alta densità

#### Scheda VGA

- 15µGold Finger nell'alloggio VGA PCIe (PCIe2/PCIe3)
- Connettore del connettore di alimentazione SLI/XFire

#### Internet

- Qualcomm® Atheros® Killer™ LAN

#### Audio

- Purity Sound™

### CPU

- Supporto di processori Socket AM3+
- Supporto di processori Socket AM3: AMD Phenom™ II X6 / X4 / X3 / X2 (fatta eccezione per 920 / 940) / Athlon II X4 / X3 / X2 / Sempron
- CPU Otto-Core Ready
- Supporto UCC (Unlock CPU Core)
- Design Digi Power
- Struttura di fase con alimentazione 8 + 2 avanzata
- Supporta CPU fino a 140 W
- Supporto tecnologia AMD Cool 'n' Quiet™
- FSB 2600 MHz (5.2 GT/s)
- Supporta la tecnologia overclocking "slegata"
- Supporta la tecnologia Hyper-Transport 3.0 (HT 3.0)

### Chipset

- Northbridge: AMD 990FX
- Southbridge: AMD SB950

### Memoria

- Tecnologia con memoria DDR3 a doppio canale
- 4 x slot DIMM DDR3
- Supporta la memoria DDR3 2450(OC)/2100 (OC)/1600/1333/1066 non ECC, senza buffer (si veda la sezione ATTENZIONE1)
- Capacità max. della memoria di sistema: 64 GB (si veda la sezione ATTENZIONE2)

- Supporta Intel® Extreme Memory Profile (XMP)1.3/1.2
- Supporta tecnologia AMD Memory Profile (AMP)

### Slot di espansione

- 3 alloggi PCI Express 2.0 x16 (PCIE2/PCIE3: modalità x16; PCIE5: modalità x4)
- 2 alloggi PCI Express 2.0 x1
- Supporto di AMD Quad CrossFireX™, 3-Way CrossFireX™ and CrossFireX™
- Supporta NVIDIA® Quad SLI™ e SLI™

### Audio

- Audio HD a 7.1 canali con Content Protection (codec audio Realtek ALC1150)
- Supporto audio Blu-ray Premium
- Supporta Purity Sound™
  - 115dB SNR DAC con amplificatore differenziale
  - TI® NE5532 (supporta l'amplificatore per cuffie di qualità superiore fino a 600 Ohm)
  - Tecnologia Direct Drive
  - copertura a schermo EMI
  - schermo isolato PCB
- Supporta DTS Connect

### LAN

- PCIE x1 LAN Gigabit 10/100/1000 Mb/s
- Qualcomm® Atheros® Killer™ E2200 Serie
- Supporta Wake-On-LAN
- Supporta Energy Efficient Ethernet 802.3az
- Supporta PXE

### I/O pannello posteriore

- 1 x porta mouse PS/2
- 1 x porta tastiera PS/2
- 1 x porta uscita SPDIF ottico
- 5 x porte USB 2.0
- 1 x porta mouse Fatal1ty (USB 2.0)
- 4 x porte USB 3.0 (ASMedia Hub)
- 1 x connettore eSATA3
- 1 x porta LAN RJ-45 con LED (ACT/LINK LED e SPEED LED)
- Jack audio HD: altoparlante posteriore/centrale/basso/ingresso linea/altoparlante anteriore/microfono

**Archiviazione**

- 5 x connettori SATA3 6,0 Gb/s, supporto RAID (RAID 0, RAID 1, RAID 0+1, JBOD e RAID 5), NCQ, AHCI e “Hot Plug”
- 1 x vite M.2\_SSD (NGFF) Socket 3, supporta moduli M.2 SATA3 6,0 Gb/s e M.2 PCI Express fino a Gen2 x2 (10 Gb/s) (M.2\_SSD (NGFF) Socket 3 condiviso con il connettore eSATA3)

**Connettore**

- 1 x header IR
- 1 x header porta COM
- 1 x header TPM
- 1 x header LED di alimentazione
- 2 x connettori ventola CPU (1 x 4 pin, 1 x 3 pin)
- 3 x connettori ventola chassis (1 x 4 pin, 2 x 3 pin)
- 1 x connettore ventola alimentazione (3 pin)
- 1 x connettore alimentazione ATX a 24 pin
- 1 x connettore alimentazione da 12 V a 8 pin (connettore alimentazione ad alta densità)
- 1 x connettore del connettore di alimentazione SLI/XFire
- 1 x connettore audio pannello anteriore
- 1 x connettore uscita SPDIF
- 2 x header USB 2.0 (supporto 4 porte USB 2.0)
- 1 x USB 3.0 verticale tipo A
- 1 x header Etron EJ188 USB 3.0 (supporta 2 porte USB 3.0)

**Caratteristiche del BIOS**

- BIOS legale 32Mb AMI UEFI con supporto GUI
- Supporta “Plug and Play”
- Eventi di wake up conformi ad ACPI 1.1
- Supporta jumperfree
- Supporto SMBIOS 2.3.1
- Multiregolazione tensione CPU, DRAM, NB, HT, CPU VDDA, PCIE VDDA, CPU NB

**CD di supporto**

- Driver, Utilità, software antivirus (versione di prova), browser e barra degli strumenti Google Chrome, Start8 (30 giorni di prova), XSplit, Killer Network Manager

**Hardware  
Monitor**

- Sensore temperatura CPU/chassis
- Tachimetro CPU/chassis/ventola alimentazione
- Ventola silenziosa CPU/chassis (consente l'autoregolazione della velocità della ventola dello chassis mediante la temperatura della CPU)
- Controllo multivelocità della ventola di CPU/chassis
- Monitoraggio tensione: +12 V, +5 V, +3,3 V, CPU Vcore

**SO**

- Microsoft® Windows® 10 a 64-bit/8.1 a 32-bit/8.1 a 64-bit/8 a 32-bit/8 a 64-bit/7 a 32-bit/7 a 64-bit

**Certificazioni**

- FCC, CE, WHQL
- ErP/EuP Ready (è necessaria alimentazione ErP/EuP ready)

\* Per informazioni dettagliate sul prodotto, visitare il nostro sito Web: <http://www.asrock.com>



*Prestare attenzione al potenziale rischio previsto nella pratica di overlocking, inclusa la regolazione delle impostazioni nel BIOS, l'applicazione di tecnologia di Untied Overclocking o l'utilizzo di strumenti di overlocking di terze parti. L'overclocking può influenzare la stabilità del sistema o perfino provocare danni ai componenti e ai dispositivi del sistema. Occorre eseguirlo a proprio rischio e spese. Non ci riterremo responsabili per possibili danni provocati da overlocking.*



- 1. Il fatto che la velocità della memoria da 2450/2100MHz sia supportata o meno, dipende dagli AM3/AM3+ CPU utilizzati. Se si desidera adottare il modulo di memoria DDR3 2450/2100 su questa scheda madre, fare riferimento all'elenco delle memorie supportate nel nostro sito web per scoprire quali sono i moduli compatibili. Sito web ASRock <http://www.asrock.com>*
- 2. A causa delle limitazioni del sistema operativo, le dimensioni effettive della memoria possono essere inferiori a 4GB per l'accantonamento riservato all'uso del sistema sotto Windows® 8 / 7. Per Windows® OS con CPU 64-bit, non c'è tale limitazione. È possibile utilizzare la RAM XFast di ASRock per utilizzare la memoria che Windows® non può utilizzare.*

## 1.3 Impostazione jumper

L'illustrazione mostra in che modo vengono impostati i jumper. Quando il cappuccio del jumper è posizionato sui pin, il jumper è "cortocircuitato". Se sui pin non è posizionato alcun cappuccio del jumper, il jumper è "aperto". L'illustrazione mostra un jumper a 3 pin i cui pin1 e pin2 sono "cortocircuitati" quando un cappuccio del jumper è posizionato su questi 2 pin.

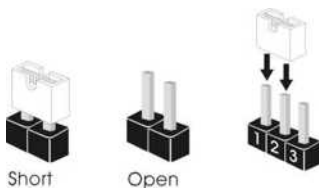

Jumper per azzerare la  
CMOS  
(CLRCMOS1)  
(vedere pag. 1, n. 21)



CLRCMOS1 consente di azzerare i dati presenti nella CMOS. Per azzerare e reimpostare i parametri del sistema alla configurazione predefinita, spegnere il computer e scollegare il cavo di alimentazione dalla rete. Dopo aver atteso 15 secondi, utilizzare un cappuccio del jumper per cortocircuitare il pin2 e il pin3 su CLRCMOS1 per 5 secondi. Tuttavia, non azzerare la CMOS subito dopo aver aggiornato il BIOS. Se è necessario azzerare la CMOS dopo l'aggiornamento del BIOS, è necessario riavviare prima il sistema e in seguito spegnerlo prima di eseguire l'operazione di azzeramento della CMOS. La password, la data, l'ora e il profilo predefinito dell'utente saranno azzerati solo se viene rimossa la batteria della CMOS.

## 1.4 Header e connettori sulla scheda



*Gli header e i connettori sulla scheda NON sono jumper. NON posizionare cappucci del jumper su questi header e connettori. Il posizionamento di cappucci del jumper su header e connettori provocherà danni permanenti alla scheda madre.*

Header sul pannello del sistema  
(PANEL1 a 9 pin)  
(vedere pag. 1, n. 20)

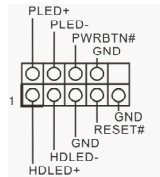

Collegare l'interruttore dell'alimentazione, l'interruttore di reset e l'indicatore dello stato del sistema sullo chassis su questo header secondo la seguente assegnazione dei pin. Annotare i pin positivi e negativi prima di collegare i cavi.



**PWRBTN (interruttore alimentazione):**

*collegare all'interruttore dell'alimentazione sul pannello anteriore dello chassis. È possibile configurare il modo in cui spegnere il sistema utilizzando l'interruttore dell'alimentazione.*

**RESET (interruttore di reset):**

*collegare all'interruttore di reset sul pannello anteriore dello chassis. Premere l'interruttore di reset per riavviare il computer se il computer si blocca e non riesce ad eseguire un normale riavvio.*

**PLED (LED alimentazione del sistema):**

*collegare all'indicatore di stato dell'alimentazione sul pannello anteriore dello chassis. Il LED è acceso quando il sistema è in funzione. Il LED continua a lampeggiare quando il sistema si trova nello stato di sospensione S1/S3. Il LED è spento quando il sistema si trova nello stato di sospensione S4 o quando è spento (S5).*

**HDLED (LED di attività disco rigido):**

*collegare al LED di attività disco rigido sul pannello anteriore dello chassis. Il LED è acceso quando il disco rigido sta leggendo o scrivendo dati.*

*Il design del pannello anteriore può cambiare a seconda dello chassis. Un modulo di pannello anteriore è composto principalmente da interruttore di alimentazione, interruttore di reset, LED di alimentazione, LED di attività disco rigido, altoparlante, ecc. Quando si collega il modulo del pannello anteriore dello chassis a questo header, accertarsi che le assegnazioni del filo e le assegnazioni del pin corrispondano correttamente.*

Header LED di alimentazione  
(PLED1 a 3 pin)  
(vedere pag. 1, n. 18)



Collegare il LED di alimentazione chassis a questo header per indicare lo stato di alimentazione del sistema.

Connettori Serial ATA3  
(SATA3\_1:  
vedere pag. 1, n. 17)  
(SATA3\_2:  
vedere pag. 1, n. 16)  
(SATA3\_3:  
vedere pag.1, n. 14)  
(SATA3\_4:  
vedere pag.1, n. 15)  
(SATA3\_5:  
vedere pag.1, n. 12)

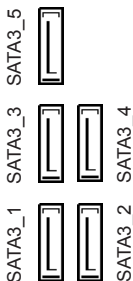

Questi cinque connettori SATA3 supportano cavi dati SATA per dispositivi di archiviazione interna, con una velocità di trasferimento dati fino a 6,0 Gb/s.

Header USB 2.0  
(USB6\_7 a 9 pin)  
(vedere pag. 1, n. 9)  
(USB8\_9 a 9 pin)  
(vedere pag. 1, n. 8)

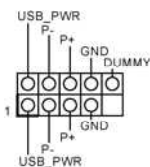

Oltre alle sei porte USB 2.0 sul pannello I/O, su questa scheda madre vi sono due header. Ciascun header USB 2.0 può supportare due porte.

Header USB 3.0  
(USB3\_5\_6 a 19 pin)  
(vedere pag. 1, n. 10)

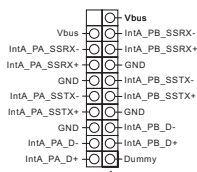

Oltre alle quattro porte USB 3.0 sul pannello I/O, vi sono un connettore e una porta su questa scheda madre. Ciascun header USB 3.0 può supportare due porte.

(USB3\_7)  
(vedere pag. 1, n. 11)



Header audio pannello anteriore  
(AUDIO1\_HD a 9 pin)  
(vedere pag. 1, n. 27)

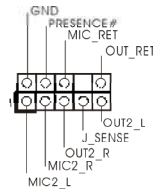

Questo header serve a collegare i dispositivi audio al pannello audio anteriore.



1. L'audio ad alta definizione supporta le funzioni Jack sensing, ma il filo del pannello sullo chassis deve supportare HDA per funzionare correttamente. Seguire le istruzioni presenti nel nostro manuale e nel manuale dello chassis per installare il sistema.
2. Se si utilizza un pannello audio AC'97, installarlo sull'header audio del pannello anteriore seguendo le fasi di seguito:
  - A. Collegare Mic\_IN (MIC) a MIC2\_L.
  - B. Collegare Audio\_R (RIN) a OUT2\_R e Audio\_L (LIN) a OUT2\_L.
  - C. Collegare Ground (GND) a Ground (GND).
  - D. MIC\_RET e OUT\_RET servono soltanto per il pannello audio HD. Non è necessario collegarli per il pannello audio AC'97.
  - E. Per attivare il microfono anteriore, andare alla scheda "MicAnt" nel pannello di controllo Realtek e regolare il "Volume di registrazione".

Header altoparlante chassis  
(SPEAKER1 a 4 pin)  
(vedere pag. 1, n. 19)

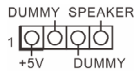

Collegare l'altoparlante dello chassis a questo header.

Connettori ventola dello chassis e di alimentazione  
(CHA\_FAN1 a 4 pin)  
(vedere pag. 1, n. 29)

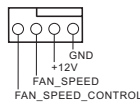

Collegare i cavi della ventola ai connettori della ventola e far corrispondere il filo nero al pin di terra.

(CHA\_FAN2 a 3 pin)  
(vedere pag. 1, n. 1)

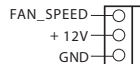

(CHA\_FAN3 a 3 pin)  
(vedere pag. 1, n. 22)



(PWR\_FAN1 a 3 pin)  
(vedere pag. 1, n. 28)



Connettori della ventola della CPU

(CPU\_FAN1 a 4 pin)  
(vedere pag. 1, n. 3)

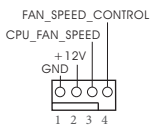

(CPU\_FAN2 a 3 pin)  
(vedere pag. 1, n. 4)

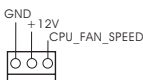

Questa scheda madre è dotata di un connettore per la ventola della CPU (Ventola silenziosa) a 4 pin. Se si decide di collegare una ventola della CPU a 3 pin, collegarla al pin 1-3.

Connettore di alimentazione ATX

(ATXPWR1 a 24 pin)  
(vedere pag. 1, n. 7)

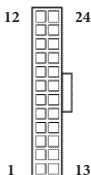

Questa scheda madre è dotata di un connettore di alimentazione ATX a 24 pin. Per utilizzare un'alimentazione ATX a 20 pin, collegarla lungo il pin1 e il pin 13.

Connettore di alimentazione ATX da 12 V

(ATX12V1 a 8 pin)  
(vedere pag. 1, n. 2)

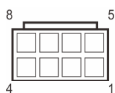

Questa scheda madre è dotata di un connettore di alimentazione ATX da 12 V a 8 pin. Per utilizzare un'alimentazione ATX a 4 pin, collegarla lungo il pin1 e il pin 5.

Connettore alimentazione SLI/XFIRE

(SLI/XFIRE\_PWR1 4 pin)  
(vedere pag. 1, n. 23)



Collegare questo connettore al connettore di alimentazione di un disco rigido quando le quattro schede grafiche sono installate su questa scheda madre.

Header modulo infrarossi

(IR1 a 5 pin)  
(vedere pag. 1, n. 24)

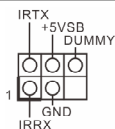

Questo header supporta un modulo infrarossi di trasmissione e ricezione wireless opzionale.

Header porta seriale  
(COM1 a 9 pin)  
(vedere pag. 1, n. 25)

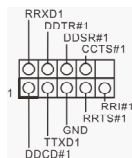

Questo header COM1 supporta un modulo di porta seriale.

Connettore uscita SPDIF  
(SPDIF\_OUT1 a 2 pin)  
(vedere pag. 1, n. 26)



Collegare il connettore SPDIF\_OUT di una scheda VGA HDMI a questo header con un cavo.

Header TPM  
(TPMS1 a 17 pin)  
(vedere pag. 1, n. 13)

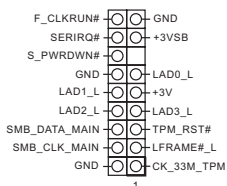

Questo connettore supporta il sistema Trusted Platform Module (TPM), che può archiviare in modo sicuro chiavi, certificati digitali, password e dati. Un sistema TPM permette anche di potenziare la sicurezza della rete, di proteggere identità digitali e di garantire l'integrità della piattaforma.

# 1 Introducción

Gracias por comprar la placa base ASRock FatalIty 990FX Killer Series, una placa base fiable fabricada según el rigurosísimo control de calidad de ASRock. Ofrece un rendimiento excelente con un diseño resistente de acuerdo con el compromiso de calidad y resistencia de ASRock.



*Ya que las especificaciones de la placa base y el software del BIOS podrán ser actualizados, el contenido que aparece en este manual estará sujeto a modificaciones sin previo aviso. Si este manual sufre alguna modificación, la versión actualizada estará disponible en el sitio web de ASRock sin previo aviso. Si necesita asistencia técnica relacionada con esta placa base, visite nuestro sitio web para obtener información específica sobre el modelo que esté utilizando. Podrá encontrar las últimas tarjetas VGA, así como la lista de compatibilidad de la CPU, en el sitio web de ASRock. Sitio web de ASRock <http://www.asrock.com>.*

## 1.1 Contenido del paquete

- Placa base ASRock FatalIty 990FX Killer Series (Factor de forma ATX)
- Guía de instalación rápida de ASRock FatalIty 990FX Killer Series
- CD de soporte de ASRock FatalIty 990FX Killer Series
- 4 cables de datos Serie ATA (SATA) (Opcional)
- 1 escudo panel I/O
- 1 tarjeta ASRock SLI\_Bridge\_2S
- 1 Tornillo para Zócalo 3 M.2\_SSD (NGFF)

## 1.2 Especificaciones

- Plataforma**
- Factor de forma ATX
  - Diseño de los Condensadores: Premium Gold (Condensadores de polímero conductor, de alta calidad, 100% fabricados en Japón)

- A-Style**
- Purity Sound™

**Características de juego**

**Alimentación de CPU**

- Conector de alimentación de alta densidad

**Tarjeta VGA**

- 15µGold Finger en ranura VGA PCIe (PCIE2/PCIE3)
- Conector de alimentación SLI/XFire

**Internet**

- Qualcomm® Atheros® Killer™ LAN

**Audio**

- Purity Sound™

**CPU**

- Compatibilidad con procesadores con conector AM3+
- Compatibilidad con procesadores con conector AM3: procesador AMD Phenom™ II X6 / X4 / X3 / X2 (excepto 920/940) / Athlon II X4 / X3 / X2 / Sempron
- Compatible con CPU de ocho núcleo
- Con soporte UCC (Unlock CPU Core)
- Diseño Digi Power
- Avanzado diseño de fases de potencia 8 + 2
- Compatible con CPU de hasta 140W
- Con soporte para tecnología Cool 'n' Quiet™ de AMD
- FSB 2600 MHz (5.2 GT/s)
- Admite tecnología de aumento de velocidad liberada
- Soporta Tecnología de Hiper-Transporte 3.0 (HT 3.0)

**Conjunto de chips**

- North Bridge: AMD 990FX
- South Bridge: AMD SB950

**Memoria**

- Tecnología de memoria de Doble Canal DDR3
- 4 ranuras DDR3 DIMM
- Compatible con memoria no-ECC, sin búfer DDR3 2450(OC) /2100(OC)/1600/1333/1066 (consulte la ADVERTENCIA1)
- Capacidad máxima de la memoria del sistema: 64GB (consulte la ADVERTENCIA2)
- Compatible con Extreme Memory Profile (XMP)1.3/1.2 de Intel®

- Admite tecnología de perfil de memoria AMD (AMP, Memory Profile Technology)

### Ranura de expansión

- 3 ranuras PCI Express 2.0 x16 (PCIE2/PCIE3: modo x16; PCIE5: modo x4)
- 2 ranura PCI Express 2.0 x1
- Compatible con AMD Quad CrossFireX™, 3-Way CrossFireX™ y CrossFireX™
- Compatible con NVIDIA® Quad SLI™ y SLI™

### Audio

- 7.1 Audio CH HD con Protección de contenido (Realtek ALC1150 Audio Codec)
- Compatible con audio Blu-ray Premium
- Compatible con Purity Sound™
  - 115dB SNR DAC con amplificador diferencial
  - TI® NE5532 (compatible con Amplificador de Auriculares Premium de hasta 600 ohmios)
  - Tecnología Direct Drive
  - cubierta protectora de EMI (interferencias electromagnéticas)
  - Protección de aislamiento PCB (circuito impreso)
- Compatible con DTS Connect

### LAN

- PCIE x1 LAN Gigabit 10/100/1000 Mb/s
- Qualcomm® Atheros® Killer™ E2200 Series
- Compatible con Wake-On-LAN
- Compatible con Ethernet de consumo eficiente de energía 802.3az
- Compatible con PXE

### Panel trasero I/O

- 1 puerto de ratón PS/2
- 1 puerto de teclado PS/2
- 1 puerto de salida SPDIF óptica
- 5 puertos USB 2.0
- 1 puerto de ratón FatalIty (USB 2.0)
- 4 puertos USB 3.0 (Concentrador ASMedia)
- 1 conector eSATA3
- 1 puerto LAN RJ-45 con LED (ACT/LINK LED y SPEED LED)
- Conector de audio HD: Altavoz trasero / Central / Graves / Entrada de línea / Altavoz frontal / Micrófono

**Almacenamiento**

- Los 5 conectores SATA3 de 6,0 Gb/s, compatibles con RAID (RAID 0, RAID 1, RAID 0+1, JBOD y RAID 5), NCQ, AHCI y “Hot Plug”
- 1 Zócalo 3 M.2\_SSD (NGFF); admite módulo M.2 SATA3 6,0 Gb/s y módulo M.2 PCI Express hasta Gen2 x2 (10 Gb/s) (el Zócalo 3 M.2\_SSD (NGFF) se comparte con el conector eSATA3)

**Conectores**

- 1 cabezal IR
- 1 cabezal de puerto COM
- 1 cabezal TPM
- 1 cabezal de indicador LED de alimentación
- 2 conectores de ventilador de la CPU (1 de 4 pines y 1 de 3 pines)
- 3 conectores de ventilador del chasis (1 de 4 pines y 2 de 3 pines)
- 1 conector de ventilador de alimentación (de 3 pines)
- 1 conector de alimentación ATX de 24 pines
- 1 conector de alimentación de 8 pines y 12V (conector de alimentación de alta densidad)
- 1 conector de alimentación SLI/XFire
- 1 conector de audio del panel frontal
- 1 conector de salida SPDIF
- 2 cabezales USB 2.0 (compatibles con 4 puertos USB 2.0)
- 1 USB 3.0 vertical de tipo A
- 1 cabezal Etron EJ188 USB 3.0 (compatible con 2 puertos USB 3.0)

**Características del BIOS**

- BIOS Legal UEFI AMI de 32Mb compatibles con interfaz gráfica de usuario
- Soporta “Plug and Play”
- Eventos de reactivación conformes con ACPI 1.1
- Soporta “jumper free setup”
- Compatible con SMBIOS 2.3.1
- Multiajuste de voltaje de CPU, DRAM, NB, HT, CPU VDDA, PCIE VDDA, CPU NB

**CD de soporte**

- Controladores, Utilidades, Software AntiVirus (Versión de prueba), Explorador y Barra de herramientas de Google Chrome, Start8 (Versión de prueba de 30 días), XSplit, Killer Network Manager

**Monitor del hardware**

- Método de sensor de temperatura de la CPU/Chasis
- Tacómetro del ventilador de alimentación/CPU/Chasis
- Ventilador silencioso de la CPU/Chasis (permite ajustar automáticamente la velocidad del ventilador del chasis mediante la temperatura de la CPU)
- Control multivelocidad del ventilador de la CPU/Chasis
- Control del voltaje: +12V, +5V, +3,3V, CPU Vcore

**SO**

- Compatible con Microsoft® Windows® 10 de 64 bits / 8.1 de 32 bits / 8.1 de 64 bits / 8 de 32 bits / 8 de 64 bits / 7 de 32 bits / 7 de 64 bits

**Certificaciones**

- FCC, CE, WHQL
- Compatible con ErP/EuP (requiere toma de alimentación compatible con ErP/EuP)

\* Para obtener más información acerca del producto, visite nuestro sitio web: <http://www.asrock.com>



*Tenga en cuenta que existen ciertos riesgos relacionados con el overlocking (sobreceleración), incluyendo el ajuste de la configuración del BIOS, aplicando la Tecnología overlocking no vinculada o utilizando las herramientas de overlocking de tercera parte. El overlocking podría afectar la estabilidad de su sistema o incluso dañar los componentes y dispositivos de su sistema. Si lo realiza, todos los riesgos y gastos derivados del overlocking serán de su entera responsabilidad. No nos hacemos responsables de posibles daños producidos por el overlocking.*



- 1. Que la velocidad de memoria de 2450/2100 MHz se admita o no se admita, depende de la configuración AM3/AM3+ Procesador que adopte. Si desea adoptar el módulo de memoria DDR3 2450/2100 en esta placa base, consulte la lista de compatibilidad de memorias en nuestro sitio Web para obtener los módulos de memoria compatibles. Sitio Web de ASRock: <http://www.asrock.com>*
- 2. Debido a las limitaciones del sistema, el tamaño real de la memoria debe ser inferior a 4GB para que el sistema pueda funcionar bajo Windows® 8 / 7. Para equipos con Windows® OS con CPU de 64-bit, no existe dicha limitación. Podrá utilizar XFast RAM de ASRock para usar la memoria que Windows® no puede utilizar.*

## 1.3 Instalación de los puentes

La instalación muestra cómo deben instalarse los puentes. Cuando la tapa de puente se coloca en los pines, el puente queda “Corto”. Si no coloca la tapa de puente en los pines, el puente queda “Abierto”. La ilustración muestra un puente de 3 pines cuyo pin 1 y pin 2 son “Cortos” cuando se coloca una tapa de puente en estos 2 pines.

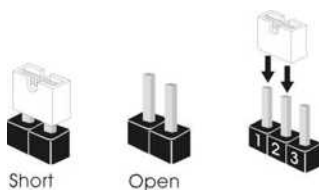

Puente de borrado de  
CMOS  
(CLRCMOS1)  
(consulte la pág.1, N.º 21)



CLRCMOS1 le permite borrar los datos del CMOS. Para borrar y restablecer los parámetros del sistema a los valores predeterminados de instalación, apague el ordenador y desenchufe el cable de alimentación de la toma de alimentación. Después de esperar 15 segundos, utilice un tapa de puente para acortar el pin2 y el pin3 en el CLRCMOS1 durante 5 segundos. Sin embargo, no borre el CMOS justo después de que haya actualizado el BIOS. Si necesita borrar el CMOS cuando acabe de actualizar el BIOS, deberá arrancar el sistema primero y, a continuación, deberá apagarlo antes de que realice el borrado del CMOS. Tenga en cuenta que la contraseña, la fecha, la hora y el perfil de usuario predeterminado serán eliminados únicamente si se retira la pila del CMOS.

## 1.4 Conectores y cabezales incorporados



Los cabezales y conectores incorporados NO son puentes. NO coloque tapas de puente sobre estos cabezales y conectores. Si coloca tapas de puente sobre los cabezales y conectores dañará de forma permanente la placa base.

Cabezal del panel del sistema  
(PANEL1 de 9 pines)  
(consulte la pág.1, N.º 20)

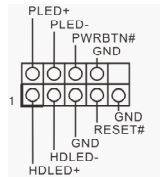

Conecte el interruptor de alimentación, restablezca el interruptor y el indicador del estado del sistema del chasis a los valores de este cabezal, según los valores asignados a los pines como se indica a continuación. Cerciórese de cuáles son los pines positivos y los negativos antes de conectar los cables.



**PWRBTN (Interruptor de alimentación):**

conéctelo al interruptor de alimentación del panel frontal del chasis. Deberá configurar la forma en la que su sistema se apagará mediante el interruptor de alimentación.

**RESET (Interruptor de reseteo):**

conéctelo al interruptor de reseteo del panel frontal del chasis. Pulse el interruptor de reseteo para resetear el ordenador si éste está bloqueado y no se puede reiniciar de forma normal.

**PLED (Indicador LED de alimentación del sistema):**

conéctelo al indicador del estado de la alimentación del panel frontal del chasis. El indicador LED permanece encendido cuando el sistema está funcionando. El indicador LED parpadea cuando el sistema se encuentra en estado de suspensión S1/S3. El indicador LED se apaga cuando el sistema se encuentra en estado de suspensión S4 o está apagado (S5).

**HDLED (Indicador LED de actividad en el disco duro):**

conéctelo al indicador LED de actividad en el disco duro del panel frontal del chasis. El indicador LED permanece encendido cuando el disco duro está leyendo o escribiendo datos.

El diseño del panel frontal puede ser diferente dependiendo del chasis. Un módulo de panel frontal consta principalmente de: interruptor de alimentación, interruptor de reseteo, indicador LED de alimentación, indicador LED de actividad en el disco duro, altavoz, etc. Cuando conecte su módulo del panel frontal del chasis a este cabezal, asegúrese de que las asignaciones de los cables y los pines coinciden correctamente.

Cabezal de indicador LED de alimentación (PLED1 de 3 pines) (consulte la pág.1, N.º 18)



Conecte el indicador LED de alimentación del chasis a este cabezal para indicar el estado de alimentación del sistema.

Conectores Serie ATA3 (SATA3\_1: consulte la pág.1, N.º 17) (SATA3\_2: consulte la pág.1, N.º 16) (SATA3\_3: consulte la pág.1, N.º 14) (SATA3\_4: consulte la pág.1, N.º 15) (SATA3\_5: consulte la pág.1, N.º 12)

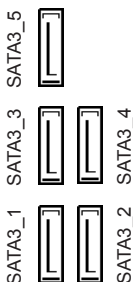

Estos cinco conectores SATA3 son compatibles con cables de datos SATA para dispositivos de almacenamiento interno con una velocidad de transferencia de datos de hasta 6,0 Gb/s.

Cabezales USB 2.0 (USB6\_7 de 9 pines) (consulte la pág.1, N.º 9) (USB8\_9 de 9 pines) (consulte la pág.1, N.º 8)

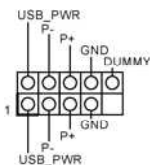

Además de seis puertos USB 2.0 en el panel I/O, esta placa base contiene dos cabezales. Cada cabezal USB 2.0 admite dos puertos.

Cabezales USB 3.0 (USB3\_5\_6 de 19 pines) (consulte la pág.1, N.º 10)

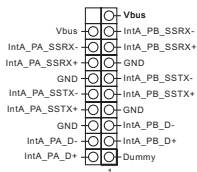

Además de cuatro puertos USB 3.0 en el panel de E/S, esta placa base cuenta con una base de conexiones y un puerto. Cada cabezal USB 3.0 admite dos puertos.

(USB3\_7) (consulte la pág.1, N.º 11)



Cabezal de audio del panel frontal  
(HD\_AUDIO1 de 9 pines)  
(consulte la pág.1, N.º 27)

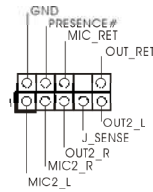

Este cabezal se utiliza para conectar dispositivos de audio al panel de audio frontal.



1. El Audio de Alta Definición (HDA, en inglés) es compatible con el método de sensor de conectores, sin embargo, el cable del panel del chasis deberá ser compatible con HDA para que pueda funcionar correctamente. Siga las instrucciones que se indican en nuestro manual y en el manual del chasis para instalar su sistema.
2. Si utiliza un panel de audio AC'97, instálelo en el cabezal de audio del panel frontal siguiendo los siguientes pasos:
  - A. Conecte Mic\_IN (MIC) a MIC2\_L.
  - B. Conecte Audio\_R (RIN) a OUT2\_R y Audio\_L (LIN) a OUT2\_L.
  - C. Conecte Ground (conexión a tierra) (GND) a Ground (GND).
  - D. MIC\_RET y OUT\_RET se utilizan únicamente para el panel de audio HD. No es necesario que los conecte en el panel de audio AC'97.
  - E. Para activar el micrófono frontal, vaya a la ficha "micrófono frontal" (FrontMic) en el panel de control de Realtek y ajuste el "Volumen de grabación" (Recording Volume).

Cabezal de altavoces del chasis  
(SPEAKER1 de 4 pines)  
(consulte la pág.1, N.º 19)

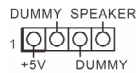

Conecte el altavoz del chasis a este cabezal.

Conectores del ventilador de alimentación y del chasis  
(CHA\_FAN1 de 4 pines)  
(consulte la pág.1, N.º 29)

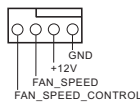

Conecte los cables del ventilador a los conectores del ventilador y haga coincidir el cable negro con el pin de conexión a tierra.

(CHA\_FAN2 de 3 pines)  
(consulte la pág.1, N.º 1)

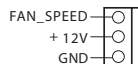

(CHA\_FAN3 de 3 pines)  
(consulte la pág.1, N.º 22)



(PWR\_FAN1 de 3 pines)  
(consulte la pág.1, N.º 28)



**Conectores del ventilador de la CPU**

(CPU\_FAN1 de 4 pines)  
(consulte la pág.1, N.º 3)

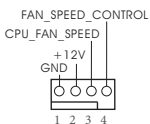

(CPU\_FAN2 de 3 pines)  
(consulte la pág.1, N.º 4)

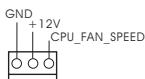

Esta placa base contiene un conector de ventilador (ventilador silencioso) de CPU de 4 pines. Si tiene pensando conectar un ventilador de CPU de 3 pines, conéctelo al Pin 1-3.

**Conector de alimentación ATX**

(ATXPWR1 de 24 pines)  
(consulte la pág.1, N.º 7)

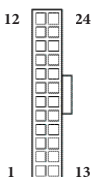

Esta placa base contiene un conector de alimentación ATX de 24 pines. Para utilizar una toma de alimentación ATX de 20 pines, conéctela en los Pines del 1 al 13.

**Conector de alimentación ATX de 12V**

(ATX12V1 de 8 pines)  
(consulte la pág.1, N.º 2)

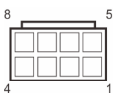

Esta placa base contiene un conector de alimentación ATX de 12V y 8 pines. Para utilizar una toma de alimentación ATX de 4 pines, conéctela en los Pines del 1 al 5.

**Conector de alimentación SLI/XFIRE**

(SLI/XFIRE\_PWR1 de 4 pines)  
(consulte la pág.1, N.º 23)



Conecte este conector con un conector de alimentación de disco duro cuando haya tres tarjetas gráficas instaladas en esta placa base.

**Cabezal de módulo infrarrojo**

(IR1 de 5 pines)  
(consulte la pág.1, N.º 24)

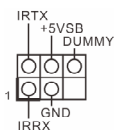

Este cabezal admite un módulo infrarrojo opcional de transmisión y recepción inalámbrico.

Cabezal de puerto serie  
(COM1 de 9 pines)  
(consulte la pág.1, N.º 25)

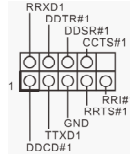

Este cabezal COM1  
admite un módulo de  
puerto serie.

Conector de salida SPDIF  
(SPDIF\_OUT1 de 2 pines)  
(consulte la pág.1, N.º 26)



Conecte el conector  
SPDIF\_OUT de una  
tarjeta VGA HDMI a este  
cabezal con un cable.

Cabezal TPM  
(TPMS1 de 17 pines)  
(consulte la pág.1, N.º 13)

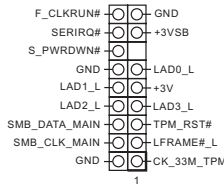

Este conector es  
compatible con el sistema  
Módulo de Plataforma  
Segura (TPM, en inglés),  
que puede almacenar  
de forma segura claves,  
certificados digitales,  
contraseñas y datos. Un  
sistema TPM también  
ayuda a aumentar la  
seguridad en la red,  
protege identidades  
digitales y garantiza  
la integridad de la  
plataforma.

# 1 Введение

Благодарим вас за приобретение надежной материнской платы ASRock Fatal1ty 990FX Killer, выпускаемой под постоянным строгим контролем компании ASRock. Эта материнская плата обеспечивает великолепную производительность и характеризуется прочной конструкцией в соответствии с требованиями компании ASRock в отношении качества и долговечности.



*По причине обновления спецификации на материнскую платформу и программного обеспечения BIOS содержимое настоящего руководства может быть изменено без предварительного уведомления. При изменении содержимого настоящего руководства его обновленная версия будет доступна на веб-сайте ASRock без предварительного уведомления. При необходимости технической поддержки, связанной с материнской платой, посетите веб-сайт и найдите на нем информацию о модели используемой вами материнской платы. На веб-сайте ASRock также можно найти самый последний перечень поддерживаемых VGA-карт и ЦП. Веб-сайт ASRock <http://www.asrock.com>.*

## 1.1 Комплект поставки

- Материнская плата ASRock Fatal1ty 990FX Killer (форм-фактор ATX)
- Краткое руководство по установке ASRock Fatal1ty 990FX Killer
- Диск с ПО для ASRock Fatal1ty 990FX Killer
- 4 х кабеля передачи данных Serial ATA (SATA) (приобретаются отдельно)
- 1 х экран панели с портами ввода-вывода
- 1 х карта ASRock SLI\_Bridge\_2S
- 1 х M.2\_SSD (NGFF) - винт гнезда 3

## 1.2 Спецификация

- Платформа**
- Форм-фактор ATX
  - Конструкция Premium Gold Capacitor (с использованием высококачественных конденсаторов из проводящих полимеров производства Японии)

- A-Style**
- Purity Sound™

**Игровое оборудование**

**Питание ЦП**

- Высокоплотный разъем питания

**Карта VGA**

- 15μGold Finger в гнезде VGA PCIe (PCIЕ2/PCIЕ3)
- разъем питания SLI/XFire

**Интернет**

- Qualcomm® Atheros® Killer™ LAN

**Аудио**

- Purity Sound™

**ЦП**

- Поддержка Socket AM3+ процессоров
- Поддержка Socket AM3 процессоров: AMD Phenom™ II X6 / X4 / X3 / X2 (не поддерживаются 920 / 940) / Athlon II X4 / X3 / X2 / Sempron
- Поддержка восьмиядерных процессоров
- Поддержка UCC (Unlock CPU Core)
- Дизайн системы питания DigiPower
- Технология Advanced 8 + 2 Power Phase Design
- Поддержка процессоров мощностью до 140 Вт
- Поддержка технологии AMD Cool 'n' Quiet™
- FSB 2600 MHz (5.2 GT/s)
- Поддержка технологии Untied Overclocking
- Поддержка технологии Hyper-Transport 3.0 (HT 3.0)

**Чипсет**

- Северный мост: AMD 990FX
- Южный мост: AMD SB950

**Память**

- Двухканальная память DDR3
- 4 x гнездо DDR3 DIMM
- Поддержка модулей памяти DDR3 2450(OC)/2100 (OC)/1600/1333/1066 Non-ECC Unbuffered (см. «ПРЕДОСТЕРЕЖЕНИЕ1»)
- Максимальный объем системной памяти: 64 Гб (см. «ПРЕДОСТЕРЕЖЕНИЕ2»)
- Поддержка Intel® Extreme Memory Profile (XMP) 1.3/1.2

- поддержка профиля AMD Memory Profile Technology (AMP)

### Гнезда расширения

- 3 x PCI Express 2.0 x16 гнезд (PCIЕ2/PCIЕ3: режим x16; PCIЕ5: режим x4)
- 2 x PCI Express 2,0 x1
- Поддержка AMD Quad CrossFireX™, 3-Way CrossFireX™ и CrossFireX™
- Поддержка NVIDIA® Quad SLI™ и SLI™

### Аудио

- 7.1-канальный звук высокой четкости HD Audio с защитой данных (аудиокодек Realtek ALC1150)
- Поддержка Premium Blu-ray Audio
- Поддержка Purity Sound™
  - 115 дБ SNR DAC с различными усилителями
  - TI® NE5532 (поддержка усилителя Premium Headset Amplifier до 600 Ом)
  - Технология Direct Drive Technology
  - Экранированная крышка EMI
  - Изолированное экранирование PCB
- Поддержка DTS-подключения

### ЛВС

- PCIЕ x1 Gigabit LAN 10/100/1000 Мб/с
- Qualcomm® Atheros® Killer™ E2200 Серия
- Поддержка Wake-On-LAN
- Поддержка Energy Efficient Ethernet 802.3az
- Поддержка PXE

### Порты ввода-вывода на задней панели

- 1 x PS/2 для мыши
- 1 x PS/2 для клавиатуры
- 1 x оптический выходной SPDIF
- 5 x USB 2.0
- 1 x Fatal1ty для мыши (USB 2.0)
- 4 x USB 3.0 (концентратор ASMedia)
- 1 x eSATA3
- 1 x RJ-45 для ЛВС с СИД (СИД АСТ/LINK и МИД SPEED)
- Разъемы HD Audio: задние динамики / центральный динамик / сабвуфер / линейный вход / передние динамики / микрофон

**Запоминающие устройства**

- 5 х разъем SATA3 6,0 Гб/с, поддержка RAID (RAID 0, RAID 1, RAID 0+1, JBOD и RAID 5), NCQ, AHCI и «горячая» замена
- 1 х M.2\_SSD (NGFF) - гнездо 3, поддерживает модуль M.2 SATA3 6,0 Гб/с и модуль M.2 PCI Express до Gen2 x2 (10 Гб/с) (M.2\_SSD (NGFF) Гнездо 3 используется совместно с разъемом eSATA3)

**Разъемы**

- 1 х колодка IR
- 1 х колодка COM-порта
- 1 х колодка TPM
- 1 х колодка светодиодного индикатора питания
- 2 х разъем для вентилятора ЦП (1 х 4-контактный, 1 х 3-контактный)
- 3 х разъема для вентилятора корпуса (1 х 4-контактный, 2 х 3-контактный)
- 1 х разъем для вентилятора блока питания (3-контактный)
- 1 х разъем питания ATX (24-контактный)
- 1 х 8-контактный разъем питания 12 В (8-контактный) (разъем High-Density Power Connector)
- 1 х разъем питания SLI/XFire
- 1 х аудиоразъем на передней панели
- 1 х выходной разъем SPDIF
- 2 х колодки USB 2.0 (поддержка 4 портов USB 2.0)
- 1 х вертикальный разъем USB 3.0 типа A
- 1 х колодка Etron EJ188 USB 3.0 (поддержка 2 портов USB 3.0)

**Особенности BIOS**

- 32 Мб AMI UEFI Legal BIOS с поддержкой ГИП
- поддержка “Plug and Play”
- Совместимость с управлением энергопотреблением по ACPI 1.1
- поддержка режима настройки без перемычек
- Поддержка SMBIOS 2.3.1
- Регулировка напряжений ЦП, DRAM, NB, HT, CPU VDDA, PCIE VDDA, CPU NB

**Диск с ПО**

- Драйвера, утилиты, антивирусное ПО (демоверсия), браузер и панель инструментов Google Chrome, Start8 (демоверсия на 30 дней), XSplit, Killer Network Manager

**Контроль  
оборудова-  
ния**

- Датчик температуры ЦП/корпуса
- Тахометр вентиляторов ЦП/корпуса/блока питания
- Малошумящий вентилятор ЦП/корпуса (с автоматической регулировкой оборотов по температуре ЦП)
- Управление оборотами вентилятора ЦП/корпуса
- Контроль напряжения: +12 В, +5 В, +3,3 В, ЦП Vcore

**ОС**

- Microsoft® Windows® 10 64-разрядная / 8.1 32-разрядная / 8.1 64-разрядная / 8 32-разрядная / 8 64-разрядная / 7 32-разрядная / 7 64-разрядная

**Сертификация**

- FCC, CE, WHQL
- Совместимость с ErP/EuP (необходим блок питания, соответствующий стандарту ErP/EuP)

\* Для получения дополнительной информации об изделии посетите наш веб-сайт:  
<http://www.asrock.com>



Следует учитывать, что разгон процессора, включая изменение настроек BIOS, применение технологии Untied Overclocking Technology и использование инструментов разгона независимых производителей, сопряжен с определенным риском. Разгон процессора может повлиять на стабильность системы или даже привести к повреждению ее компонентов и устройств. Вы выполняете разгон процессора на ваш собственный риск и за свой счет. Мы не несем ответственность за возможный ущерб, вызванный разгоном процессора.



1. Поддержка частоты памяти 2450/2100 МГц зависит от используемого процессора с разъемом AM3/AM3+. Для использования модуля памяти DDR3 2450/2100 на этой материнской плате ознакомьтесь со списком поддерживаемых модулей памяти на нашем веб-сайте, чтобы выбрать совместимые модули памяти.  
Веб-сайт ASRock <http://www.asrock.com>
2. В силу ограничения операционной системы фактическая емкость памяти может быть меньше 4Гб для обеспечения резервного места для использования системой Windows® 8 / 7. Таких ограничений нет для Windows® OS с 64-bit центральным процессором. Для использования той памяти, которую ОС Windows® не может использовать, используйте ASRock XFast RAM.

## 1.3 Установка перемычек

Установка перемычек показана на рисунке. При установке колпачковой пере­мычки на контакты перемычка «замкнута». Если колпачковая пере­мычка на контакты не установлена, пере­мычка «разомкнута». На рисунке показана 3-контактная пере­мычка с замкнутыми контактами 1 и 2 при установке на них колпачковой пере­мычки.

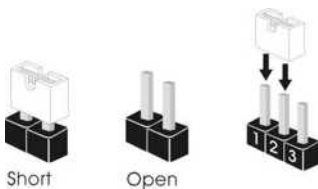

Пере­мычка сброса настроек CMOS (CLRCMOS1)  
(См. стр. 1, № 21)



CLRCMOS1 используется для удаления данных CMOS. Чтобы сбросить и обнулить параметры системы на настройки по умолчанию, выключите компьютер и извлеките отключите кабель питания от источника питания. Подождите 15 секунд и пере­мычкой замкните контакты 2 и 3 на CLRCMOS1 на 15 секунд. Не сбрасывайте настройки CMOS сразу после обновления BIOS. При необходимости сбросить настройки CMOS сразу после обновления BIOS сначала перезагрузите систему, а затем выключите компьютер перед сбросом настроек CMOS. Учтите, что пароль, дата, время и профиль пользователя по умолчанию сбрасываются только в том случае, если из­влечь батарею CMOS.

## 1.4 Колодки и разъемы, расположенные на материнской плате



Расположенные на материнской плате колодки и разъемы перемычками НЕ являются. НЕ устанавливайте на эти колодки и разъемы колпачковые перемычки. Установка колпачковых перемычек на эти колодки и разъемы может вызвать неустранимое повреждение материнской платы.

Колодка системной панели  
(9-контактная, PANEL1)  
(См. стр. 1, № 20)

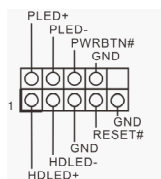

Подключите расположенные на корпусе выключатель питания, кнопку перезагрузки и индикатор состояния системы к этой колодке в соответствии с распределением контактов, приведенным ниже. Перед подключением кабелей определите положительный и отрицательный контакты.



### **PWRBTN (кнопка питания):**

Подключение кнопки питания, расположенной на передней панели корпуса. Можно настроить порядок выключения системы с использованием кнопки питания.

### **RESET (кнопка перезагрузки):**

Подключение кнопки перезагрузки системы, расположенной на передней панели корпуса. Нажмите кнопку перезагрузки, чтобы перезапустить компьютер, если он завис и нормальный запуск невозможен.

### **PLED (светодиодный индикатор питания системы):**

Подключение индикатора состояния, расположенного на передней панели корпуса. Светодиодный индикатор горит, когда система работает. Когда система находится в режиме ожидания S1/S3, светодиод мигает. Когда система находится в режиме ожидания S4 или выключена (S5), светодиод не горит.

### **HDLED (светодиодный индикатор работы жесткого диска):**

Подключение светодиодного индикатора работы жесткого диска, расположенного на передней панели корпуса. Светодиодный индикатор горит, когда жесткий диск выполняет считывание или запись данных.

Передняя панель может быть разной на разных корпусах. В основном передняя панель включает в себя кнопку питания, кнопку перезагрузки, светодиодный индикатор питания, светодиодный индикатор работы жесткого диска, динамик и т. д. При подключении передней панели к этой колодке правильно подключайте провода к контактам.



## Аудиоколодка передней панели

(9-контактная, HD\_AUDIO1)

(См. стр. 1, № 27)

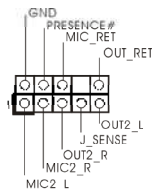

Эта колодка предназначена для подключения аудиоустройств к передней аудиопанели.



1. Аудиосистема высокого разрешения поддерживает функцию распознавания разъема, но для ее правильной работы необходимо, чтобы провод панели корпуса поддерживал передачу сигналов HDA. Инструкции по установке системы см. в этом руководстве и руководстве на корпус.
2. При использовании аудиопанели AC'97 подключите ее к аудиоколодке передней панели, как указано далее:
  - A. Подключите Mic\_IN (MIC) к MIC2\_L.
  - B. Подключите Audio\_R (RIN) к OUT2\_R, Audio\_L (LIN) к OUT2\_L.
  - C. Подключите провод заземления (GND) к контакту заземления (GND).
  - D. Контакты MIC\_RET и OUT\_RET используются только для аудиопанели высокого разрешения. При использовании аудиопанели AC'97 их подключать не нужно.
  - E. Чтобы активировать передний микрофон, перейдите на вкладку FrontMic панели управления Realtek и отрегулируйте параметр Recording Volume (Громкость записи).

## Колодка динамика корпуса

(4-контактная, SPEAKER1)

(См. стр. 1, № 19)

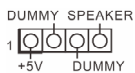

Предназначена для подключения динамика корпуса.

## Разъемы для вентиляторов корпуса и блока питания

(4-контактный, CHA\_FAN1)

(См. стр. 1, № 29)

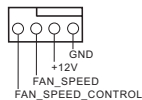

Предназначены для подключения кабелей разъемов вентиляторов и подключения черного провода к заземлению.

(3-контактный, CHA\_FAN2)

(См. стр. 1, № 1)

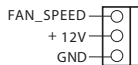

(3-контактный, CHA\_FAN3)

(См. стр. 1, № 22)



(3-контактный, PWR\_FAN1)

(См. стр. 1, № 28)



Разъемы вентиляторов ЦП

(4-контактный, CPU\_FAN1)

(См. стр. 1, № 3)

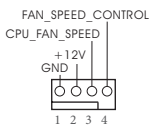

(3-контактный, CPU\_FAN2)

(См. стр. 1, № 4)

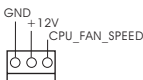

Эта материнская плата снабжена 4-контактным разъемом для малошумящего вентилятора ЦП. Если вы собираетесь подключить 3-контактный вентилятор охлаждения процессора, подключайте его к контактам 1-3.

Разъем питания ATX

(24-контактный, ATXPWR1)

(См. стр. 1, № 7)

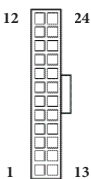

Эта материнская плата снабжена 24-контактным разъемом питания ATX. Чтобы использовать 20-контактный разъем питания ATX, подключите его вдоль контакта 1 и контакта 13.

Разъем питания ATX

12 В

(8-контактный, ATX12V1)

(См. стр. 1, № 2)



Эта материнская плата снабжена 8-контактным разъемом питания ATX 12 В. Чтобы использовать 4-контактный разъем питания ATX, подключите его вдоль контакта 1 и контакта 5.

Разъем питания SLI/XFIRE

(4-контактный, SLI/XFIRE\_PWR1)

(См. стр. 1, № 23)



Этот разъем предназначен для подключения разъемов питания жесткого диска при установке на материнскую плату три видеокарт.

Колодка инфракрасного модуля

(5-контактная, IR1)

(См. стр. 1, № 24)

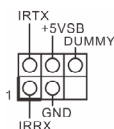

Эта колодка поддерживает дополнительную беспроводную передачу и прием сигналов инфракрасного модуля.

Колodka последовательного порта  
(9-контактная, COM1)  
(См. стр. 1, № 25)

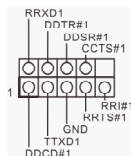

Колodka COM1 поддерживает подключение модуля последовательного порта.

Выходной разъем SPDIF  
(2-контактный, SPDIF\_OUT1)  
(См. стр. 1, № 26)



Подключите разъем SPDIF\_OUT карты HDMI VGA к этой колodka при помощи кабеля.

Колodka TPM  
(17-контактная, TPMS1)  
(См. стр. 1, № 13)

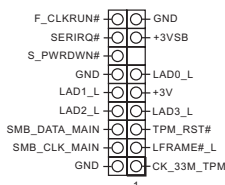

Этот разъем обеспечивает поддержку системы Trusted Platform Module (TPM), которая способна обеспечить надежное хранение ключей, цифровых сертификатов, паролей и данных. Система TPM также повышает уровень сетевой безопасности, защищает цифровые идентификаторы и обеспечивает целостность платформы.

# 1 Introdução

Obrigado por ter comprado a placa principal ASRock Fatal1ty 990FX Killer Series, uma placa principal fiável produzida sob os rigorosos critérios de controlo de qualidade da ASRock. Esta placa principal oferece um excelente desempenho com um design robusto em conformidade com o compromisso da ASRock em fabricar produtos de qualidade e resistentes.



*Dado que as especificações da placa principal e o software do BIOS poderão ser actualizados, o conteúdo deste manual estará sujeito a alterações sem aviso prévio. Caso ocorram modificações a este manual, a versão actualizada estará disponível no Web site da ASRock sem aviso prévio. Se necessitar de assistência técnica relacionada com esta placa principal, visite o nosso Web site para obter informações específicas acerca do modelo que está a utilizar. Também poderá encontrar a lista de placas VGA e CPU mais recentes suportadas no Web site da ASRock. Web site da ASRock <http://www.asrock.com>.*

## 1.1 Conteúdo da embalagem

- Placa principal ASRock Fatal1ty 990FX Killer Series (Formato ATX)
- Guia de instalação rápida da ASRock Fatal1ty 990FX Killer Series
- CD de suporte da ASRock Fatal1ty 990FX Killer Series
- 4 x Cabos de dados Serial ATA (SATA) (Opcional)
- 1 x Painel de E/S
- 1 x Placa Bridge\_SLI\_2S ASRock
- 1 x Parafuso M.2\_SSD (NGFF) Socket 3

## 1.2 Especificações

- Plataforma**
- Formato ATX
  - Design de condensadores banhados a ouro de alta qualidade (Condensadores de polímeros condutores de alta qualidade 100% fabricados no Japão)

- Estilo A**
- Purity Sound™

**Armadura para jogos**

**Potência de CPU**

- Conector de alimentação de alta densidade

**Placa VGA**

- Contactos banhados a ouro de 15µ em ranhura VGA PCIe (PCIe2/PCIe3)
- Conector de alimentação SLI/XFire

**Internet**

- Qualcomm® Atheros® Killer™ LAN

**Audio**

- Purity Sound™

**CPU**

- Suporte para processadores AM3+
- Suporte para processadores AM3: Processador AMD
- Phenom™ II X6 / X4 / X3 / X2 (exceto 920 / 940) / Athlon II X4 / X3 / X2 / Sempron
- Preparado para CPU de oito núcleos
- Suporta UCC (Unlock CPU Core)
- Design Digi Power
- Alimentação de 8 + 2 fases
- Suporta CPU até 140W
- Suporta a tecnologia Cool 'n' Quiet da AMD
- FSB de 2600 MHz (5,2 GT/s)
- Suporta a tecnologia Untied Overclocking
- Suporta a tecnologia Hyper-Transport 3.0 (HT 3.0)

**Chipset**

- North Bridge: AMD 990FX
- South Bridge: AMD SB950

**Memória**

- Tecnologia de memória DDR3 de dois canais
- 4 x ranhuras DIMM DDR3
- Suporta memória DDR3 2450(OC)/2100(OC)/1600/1333/1066, não ECC, sem memória intermédia (consultar AVISO1)
- Capacidade máxima da memória do sistema: 64GB (consultar AVISO2)

- Suporta Extreme Memory Profile (XMP)1.3/1.2 da Intel®
- Suporta Tecnologia de Perfil de Memória AMD (AMP)

### Ranuras de expansão

- 3 x ranhuras PCI Express 2.0 x16 (PCIe2/PCIe3: modo x16; PCIe5: modo x4)
- 2 x ranhura PCI Express 2.0 x1
- Suporta AMD Quad CrossFireX™, 3-Way CrossFireX™ e CrossFireX™
- Suporta Quad SLI™ e SLI™ da NVIDIA®

### Áudio

- Áudio HD de 7.1 canais com protecção de conteúdo (Codec de áudio Realtek ALC1150)
- Suporte áudio Blu-ray superior
- Suporta Purity Sound™
  - 115dB SNR DAC com amplificador diferencial
  - TI® NE5532 (suporta amplificador de auscultadores premium até 600 Ohms)
  - Tecnologia de accionamento directo
  - cobertura de blindagem EMI
  - Blindagem de isolamento PCB
- Suporta a tecnologia DTS Connect

### LAN

- PCIe x1 LAN Gigabit a 10/100/1000 Mb/s
- Qualcomm® Atheros® Killer™ E2200 Series
- Suporta Wake-On-LAN
- Suporta IEEE 802.3az
- Suporta PXE

### E/S do painel traseiro

- 1 x Porta PS/2 para rato
- 1 x Porta PS/2 para teclado
- 1 x Porta de saída SPDIF óptica
- 5 x portas USB 2.0
- 1 x Porta para rato FatalIty (USB 2.0)
- 4 x Portas USB 3.0 (ASMedia Hub)
- 1 x Conector eSATA3
- 1 x Porta LAN RJ-45 com LED (LED ACT/LIGAÇÃO e LED DE VELOCIDADE)
- Ficha de áudio HD: Altifalante traseiro / Central / Graves / Entrada de linha / Altifalante frontal / Microfone

**Armazena-  
mento**

- 5 x conectores SATA3 a 6,0 Gb/s, com suporte para RAID (RAID 0, RAID 1, RAID 0+1, JBOD e RAID 5), NCQ, AHCI e “Hot Plug”
- 1 x M.2\_SSD (NGFF) Socket 3, suporta módulo M.2 SATA3 6,0 Gb/s e módulo M.2 PCI Express até Gen2 x2 (10 Gb/s) (M.2\_SSD (NGFF) Socket 3 é partilhado com o conector eSATA3)

**Conector**

- 1 x Terminal IV
- 1 x Terminal de porta COM
- 1 x Terminal TPM
- 1 x Conector para LED de alimentação
- 2 x Conectores da ventoinha da CPU (1 x 4 pinos, 1 x 3 pinos)
- 3 x Conectores da ventoinha do chassis (1 x 4 pinos, 2 x 3 pinos)
- 1 x Conector da ventoinha de alimentação (3 pinos)
- 1 x conector de alimentação de 24 pinos ATX
- 1 x conector de alimentação de 12V com 8 pinos (Conector de alimentação de alta densidade)
- 1 x Conector de alimentação SLI/XFire
- 1 x conector de áudio do painel frontal
- 1 x Conector de saída SPDIF
- 2 x terminais USB 2.0 (suporte para 4 portas USB 2.0)
- 1 x USB 3.0 Tipo A Vertical
- 1 x terminal Etron EJ188 USB 3.0 (suporte para 2 portas USB 3.0)

**Funciona-  
lidades da  
BIOS**

- BIOS UEFI oficial da AMI com 32Mb com suporte de interface
- Suporta dispositivos “Plug and Play”
- Eventos de reactivação compatíveis com ACPI 1.1
- Suporta dispositivos sem jumper
- Suporta SMBIOS 2.3.1
- Multi-ajuste de tensão de CPU, DRAM, NB, HT, CPU VDDA, PCIE VDDA, CPU NB

**CD de  
suporte**

- Controladores, Utilitários, Software antivírus (versão de avaliação), Navegador e Barra de Ferramentas Google Chrome, Start8 (30 dias de avaliação), XSplit, XSplit, Killer Network Manager

**Monitor de hardware**

- Sensor de temperatura de CPU/Chassis
- Taquímetro de ventoinha de CPU/Chassis/Alimentação
- Ventoinha de CPU/Chassis silenciosa (Permite o ajuste automático da velocidade da ventoinha do chassis através da temperatura da CPU)
- Controlo de velocidade da ventoinha de CPU/Chassis
- Monitorização da tensão: +12V, +5V, +3,3V, CPU Vcore

**Sistema Operativo**

- Compatível com Microsoft® Windows® 10 64-bits / 8.1 32-bits / 8.1 64-bits / 8 32-bits / 8 64-bits / 7 32-bits / 7 64-bits

**Certificações**

- FCC, CE, WHQL
- Preparada para ErP/EuP (é necessária uma fonte de alimentação preparada para ErP/EuP)

\* Para obter informações detalhadas acerca do produto, visite o nosso Web site: <http://www.asrock.com>



Tenha em atenção que o overlocking inclui um determinado grau de risco, incluindo o ajuste das definições na BIOS, a aplicação de tecnologia Untied Overclocking ou a utilização de ferramentas de overlocking de terceiros. O overlocking poderá afectar a estabilidade do sistema, ou mesmo causar danos aos componentes e dispositivos do seu sistema. Overlocking deverá ser efectuado por sua conta e risco. Não nos responsabilizamos por possíveis danos causados pelo overlocking.



1. O suporte às velocidades 2450/2100MHz de memória depende da CPU AM3/AM3+ adotada. Se você quiser adotar módulos de memória DDR3 2450/2100 nesta placa, por favor verifique a lista de suporte de memórias em nosso website para as memórias compatíveis. Website ASRock: <http://www.asrock.com>
2. Devido a limitações do sistema operacional, o tamanho da memória pode ser menor que 4GB para a reserva de uso do sistema no Windows® 8 / 7. No Windows® 64-bit com CPU de 64-bit, não existe esta limitação. ode utilizar o ASRock XFast RAM para dar uso à memória que o Windows® não utiliza.

## 1.3 Configuração dos jumpers

A imagem abaixo ilustra como os jumpers são configurados. Quando a tampa do jumper é colocada nos pinos, o jumper é "Curto". Se não for colocada uma tampa de jumper nos pinos, o jumper é "Aberto". A imagem ilustra um jumper de 3 pinos cujos pino1 e pino2 estão "Curtos" quando a tampa do jumper é colocada nestes 2 pinos.

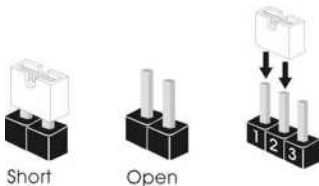

Jumper para limpar o  
CMOS  
(CLRCMOS1)  
(consultar p.1, N.º 21)



CLRCMOS1 permite-lhe limpar os dados no CMOS. Para limpar e repor os parâmetros do sistema para os valores predefinidos, encerre o computador e desligue a ficha da tomada. Depois de aguardar 15 segundos, utilize uma tampa de jumper para ligar o pino2 e o pino3 no CLRCMOS1 durante 5 segundos. No entanto, não limpe o CMOS logo após ter efectuado a actualização da BIOS. Se precisar de limpar o CMOS logo após ter terminado uma actualização da BIOS, deverá primeiro iniciar o sistema e voltar a encerrá-lo antes de efectuar a acção de limpeza do CMOS. Tenha em atenção que a palavra-passe, data, hora e perfil predefinido de utilizador apenas serão limpos se a pilha do CMOS for retirada.

## 1.4 Terminais e conectores integrados



Os terminais e conectores integrados NÃO são jumpers. NÃO coloque tampas de jumpers sobre estes terminais e conectores. Colocar tampas de jumpers sobre os terminais e conectores irá causar danos permanentes à placa principal.

Terminal do painel de sistema  
(PAINEL1 de 9 pinos)  
(consultar p.1, N.º 20)

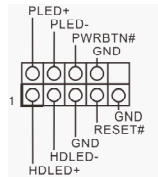

Ligue o botão de alimentação, o botão de reposição e o indicador do estado do sistema no chassis a este terminal de acordo com a descrição abaixo. Tenha em atenção os pinos positivos e negativos antes de ligar os cabos.



**PWRBTN (Botão de alimentação):**

Ligue ao botão de alimentação no painel frontal do chassis. Pode configurar a forma para desligar o seu sistema através do botão de alimentação.

**RESET (Botão de reposição):**

Ligue ao botão de reposição no painel frontal do chassis. Prima o botão de reposição para reiniciar o computador caso este bloqueie e não seja possível reiniciar normalmente.

**PLED (LED de alimentação do sistema):**

Ligue ao indicador do estado da alimentação no painel frontal do chassis. O LED ficará acesso quando o sistema estiver em funcionamento. O LED ficará intermitente quando o sistema estiver nos estados de suspensão S1/S3. O LED ficará desligado quando o sistema estiver no estado de suspensão S4 ou desligado (S5).

**HDLED (LED de actividade do disco rígido):**

Ligue ao LED de actividade do disco rígido no painel frontal do chassis. O LED ficará acesso quando o disco rígido estiver a ler ou a escrever dados.

O design do painel frontal poderá variar dependendo do chassis. Um módulo de painel frontal consiste principalmente em um botão de alimentação, um botão de reposição, um LED de alimentação, um LED de actividade do disco rígido, um altifalante, etc. Ao ligar o seu módulo de painel frontal do chassis a este conector, certifique-se de que os fios e os pinos têm uma correspondência exacta.

Conector do LED de alimentação  
(PLED1 de 3 pinos)  
(consultar p.1, N.º 18)



Ligue o LED de alimentação do chassis a este terminal para indicar o estado de alimentação do sistema.

Conectores ATA3 de série  
(SATA3\_1:  
consultar p.1, N.º 17)  
(SATA3\_2:  
consultar p.1, N.º 16)  
(SATA3\_3:  
consultar p.1, N.º 14)  
(SATA3\_4:  
consultar p.1, N.º 15)  
(SATA3\_5:  
consultar p.1, N.º 12)

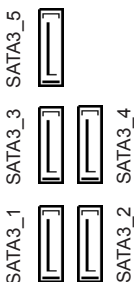

Estes cinco conectores SATA3 suportam cabos de dados SATA para dispositivos de armazenamento interno com uma velocidade de transferência de dados de até 6,0 Gb/s.

Terminais USB 2.0  
(USB6\_7 de 9 pinos)  
(consultar p.1, N.º 9)  
(USB8\_9 de 9 pinos)  
(consultar p.1, N.º 8)

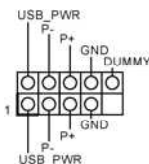

Para além das seis portas USB 2.0 no painel de E/S, existem dois terminais nesta placa principal. Cada terminal USB 2,0 é capaz de suportar duas portas.

Terminais USB 3.0  
(USB3\_5\_6 de 19 pinos)  
(consultar p.1, N.º 10)

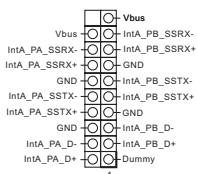

Para além de quatro portas USB 3.0 no painel de entrada/saída, existe um conector e uma porta nesta placa principal. Cada terminal USB 3.0 é capaz de suportar duas portas.

(USB3\_7)  
(consultar p.1, N.º 11)



Terminal de áudio do  
painel frontal  
(HD\_AUDIO1 de 9 pinos)  
(consultar p.1, N.º 27)

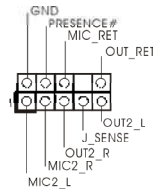

Este terminal destina-se  
à ligação de dispositivos  
áudio ao painel de áudio  
frontal.



1. O Áudio de alta definição suporta Detecção de ficha, mas o cabo de painel no chassis deverá suportar HDA para funcionar correctamente. Siga as instruções no nosso manual e no manual do chassis para instalar o seu sistema.
2. Se utilizar um painel de áudio AC'97, instale-o no terminal de áudio do painel frontal de acordo com os passos abaixo:
  - A. Ligue Mic\_IN (MIC) a MIC2\_L.
  - B. Ligue Audio\_R (RIN) a OUT2\_R e Audio\_L (LIN) a OUT2\_L.
  - C. Ligue Terra (GND) a Terra (GND).
  - D. MIC\_RET e OUT\_RET destinam-se apenas ao painel de áudio HD. Não precisa de os ligar para o painel de áudio AC'97.
  - E. Para activar o microfone frontal, aceda ao separador "Microfone Frontal" no painel de controlo Realtek e ajuste o "Volume de gravação".

Terminal do altifalante do  
chassis  
(SPEAKER1 de 4 pinos)  
(consultar p.1, N.º 19)

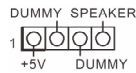

Ligue o altifalante do  
chassis a este terminal.

Conectores da ventoinha  
do chassis e alimentação  
(CHA\_FAN1 de 4 pinos)  
(consultar p.1, N.º 29)

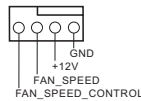

Ligue os cabos da ven-  
toinha aos conectores  
da ventoinha colocando  
o cabo preto no pino de  
ligação à terra.

(CHA\_FAN2 3 pinos)  
(consultar p.1, N.º 1)

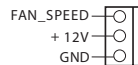

(CHA\_FAN3 de 3 pinos)  
(consultar p.1, N.º 22)



(PWR\_FAN1 de 3 pinos)  
(consultar p.1, N.º 28)



**Conectores da ventoinha da CPU**

(CPU\_FAN1 de 4 pinos)  
(consultar p.1, N.º 3)

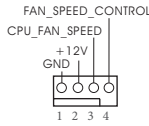

(CPU\_FAN2 de 3 pinos)  
(consultar p.1, N.º 4)

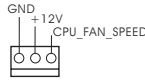

Esta placa principal inclui um conector de ventoinha de CPU (Ventoinha silenciosa) de 4 pinos. Se pretender ligar uma ventoinha de CPU de 3 pinos, ligue-a ao Pino 1-3.

**Conector de alimentação ATX**

(ATXPWR1 de 24 pinos)  
(consultar p.1, N.º 7)

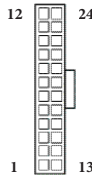

Esta placa principal inclui um conector de alimentação de 12V ATX de 24 pinos. Para utilizar uma fonte de alimentação ATX de 20 pinos, introduza-a no Pino 1 e Pino 13.

**Conector de alimentação de 12V ATX**

(ATX12V1 de 8 pinos)  
(consultar p.1, N.º 2)

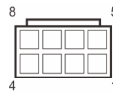

Esta placa principal inclui um conector de alimentação de 12V ATX de 8 pinos. Para utilizar uma fonte de alimentação ATX de 4 pinos, introduza-a no Pino 1 e Pino 5.

**Conector de alimentação SLI/XFIRE**

(SLI/XFIRE\_PWR1 de 4 pinos)  
(consultar p.1, N.º 23)



Ligue este conector a um conector de alimentação do disco rígido quando existirem três placas gráficas instaladas nesta placa principal.

**Terminal do módulo de infra-vermelhos**

(IR1 de 5 pinos)  
(consultar p.1, N.º 24)

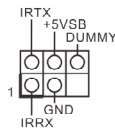

Este terminal suporta um módulo de infra-vermelhos opcional para transmissão e recepção sem fios.

Terminal de porta de série  
(COM1 de 9 pinos)  
(consultar p.1, N.º 25)

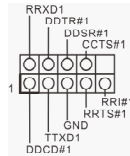

Este terminal COM1  
suporta um módulo de  
porta de série.

Conector de saída SPDIF  
(SPDIF\_OUT1 de 2 pinos)  
(consultar p.1, N.º 26)



Ligue o conector SPDIF\_  
OUT da placa VGA  
HDMI a este terminal  
através de um cabo.

Terminal TPM  
(TPMS1 de 17 pinos)  
(consultar p.1, N.º 13)

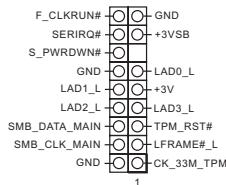

Este conector suporta  
um sistema com  
Módulo de Plataforma  
Confiável (TPM), que  
pode armazenar com  
segurança chaves,  
certificados digitais,  
palavras-passe e  
dados. Um sistema  
TPM também ajuda a  
melhorar a segurança  
de rede, a proteger  
identidades digitais e a  
garantir a integridade da  
plataforma.

# 1 Giriş

Zorlu kalite kontrol süreçlerinden geçmiş olan ASRock Fatal1ty 990FX Killer Serisi anakartını satın aldığınız için teşekkür ederiz. Sağlam tasarımı ile ASRock'ın kalite ve dayanıklılık taahhüdüne uygun şekilde mükemmel performans sağlar.



*Anakart özellikleri ve BIOS yazılımı güncellenebileceğinden, bu kılavuzun içeriği herhangi bir bildirimde bulunulmaksızın değiştirilebilir. Bu kılavuz üzerinde herhangi bir değişiklik yapılması halinde, güncellenmiş sürüm, herhangi bir bildirim yapılmaksızın ASRock'ın web sitesinde yer alacaktır. Bu anakart ile ilgili olarak teknik destek almak istiyorsanız, lütfen kullandığımız model hakkında özel bilgiler için web sitemizi ziyaret edin. En güncel VGA kartları ve CPU destek listelerini de ASRock'ın web sitesinden bulabilirsiniz. ASRock'ın web sitesi <http://www.asrock.com>.*

## 1.1 Ambalaj İçeriği

- ASRock Fatal1ty 990FX Killer Serisi Anakartı (ATX Form Faktörü)
- ASRock Fatal1ty 990FX Killer Serisi Hızlı Kurulum Kılavuzu
- ASRock Fatal1ty 990FX Killer Serisi Destek CD'si
- 4 x Seri ATA (SATA) Veri Kablosu (İsteğe Bağlı)
- 1 x I/O Panel Kalkanı
- 1 x ASRock SLI\_Bridge\_2S Kartı
- 1 x adet M.2\_SSD (NGFF) Yuva 3 Vida

## 1.2 Özellikler

- Platform**
- ATX Form Faktörü
  - Premium Gold Sığa tasarımı (%100 Japon-malı kaliteli İletken Polimer Sığalar)

- A-Stili**
- Purity Sound™

- Oyun Zırhı**
- CPU Gücü**
- Yüksek Yoğunluklu Güç Bağlayıcısı

**VGA Kartı**

- VGA PCIe Yuvasında (PCIe2/PCIe3) 15µ Gold Finger
- SLI/XFire güç bağlayıcısı

**İnternet**

- Qualcomm® Atheros® Killer™ LAN

**Ses**

- Purity Sound™

- CPU**
- Soket AM3+ işlemcileri desteği
  - Soket AM3 işlemcileri desteği: AMD Phenom™ II X6 / X4 / X3 / X2 (920 / 940 hariç) / Athlon II X4 / X3 / X2 / Sempron işlemcileri
  - Sekiz Çekirdekli CPU Desteği
  - UCC özelliğini destekler - CPU çekirdeği Kilidi Açma
  - Dijital Güç Tasarımı
  - Gelişmiş 8 + 2 Güç Fazı Tasarımı
  - 140W'ye kadar CPU'yu destekler
  - AMD'nin Cool 'n' Quiet™ Teknolojisini Destekler
  - FSB 2600 MHz (5,2 GT/sn)
  - Untied Overclocking Teknolojisini destekler
  - Hyper-Transport 3.0 (HT 3.0) Teknolojisini Destekler

- Yonga kümesi**
- Kuzey Köprüsü: AMD 990FX
  - Güney Köprüsü: AMD SB950

- Bellek**
- Çift Kanallı DDR3 Bellek Teknolojisi
  - 4 x DDR3 DIMM yuvaları
  - DDR3 2450(OC)/2100(OC)/1600/1333/1066 ECC olmayan, ara belleğe alınmamış belleği destekler (bkz. DİKKAT1)

- Maksimum sistem belleği kapasitesi: 64GB (bkz. DİKKAT2)
- Intel® Üstün Bellek Profili (XMP)1.3/1.2 özelliğini destekler
- AMD Bellek Profili Teknolojisini (AMP) destekler

### Genişletme Yuvası

- 3 x PCI Express 2.0 x16 yuva (PCIE2/PCIE3: x16 modu; PCIE5: x4 modu)
- 2 x PCI Express 2,0 x1 yuva
- AMD Quad CrossFireX™, 3-Way CrossFireX™ ve CrossFireX™ birimlerini destekler
- NVIDIA® Quad SLI™ ve SLI™ birimlerini destekler

### Ses

- İçerik Koruma Özelliği ile 7.1 CH HD Ses (Realtek ALC1150 Ses Codec Bileşeni)
- Üstün Blu-ray ses desteği
- Purity Sound™
  - Diferansiyel yükselticili 115dB SNR DAC
  - TI® NE5532 (600 Ohm'a kadar Premium Kulaklık Yükselticisi desteği)
  - Direct Drive Teknolojisi
  - EMI ekranlama koruyucusu
  - PCB izole ekranlaması desteğine sahiptir
- DTS Connect işlevini destekler

### LAN

- PCIE x1 Gigabit LAN 10/100/1000 Mb/s
- Qualcomm® Atheros® Killer™ E2200 Serisi
- LAN Açılışını Destekler
- Enerji Verimliliğine Sahip Ethernet 802.3az işlevini destekler
- PXE özelliğini destekler

### Arka Panel I/O

- 1 x PS/2 Fare Bağlantı Noktası
- 1 x PS/2 Klavye Bağlantı Noktası
- 1 x Optik SPDIF Çıkışı Bağlantı Noktası
- 5 x USB 2.0 Bağlantı noktası
- 1 x Fatal1ty Fare Bağlantı Noktası (USB 2.0)
- 4 x USB 3.0 Bağlantı Noktası (ASMedia Hub)
- 1 x eSATA3 Bağlayıcısı

- LED'e sahip 1 x RJ-45 LAN Bağlantı Noktası (ACT/LINK LED ve SPEED LED)
- HD Ses Jakı: Arka Hoparlör / Merkezi / Bas / Hat Girişi / Ön Hoparlör / Mikrofon

### Depolama

- 5 x SATA3 6,0 Gb/s bağlayıcıları, RAID (RAID 0, RAID 1, RAID 0+1, JBOD ve RAID 5), NCQ, AHCI ve "Hot Plug" işlevlerini destekler
- 1 x adet M.2\_SSD (NGFF) Yuva 3, M.2 SATA3 6,0 Gb/s modülü ve M.2 PCI Express modülü destekler. Gen2 x2 (10 Gb/s)'ye kadar (M.2\_SSD (NGFF) Yuva 3 eSATA3 konektörüyle paylaşılır)

### Bağlayıcı

- 1 x IR bağlantısı
- 1 x COM Bağlantı noktası bağlantısı
- 1 x TPM bağlantısı
- 1 x Güç LED bağlantısı
- 2 x CPU Fan bağlayıcıları (1 x 4-pin, 1 x 3-pin)
- 3 x Kasa Fanı konektörü (1 x 4-pin, 2 x 3-pin)
- 1 x Güç Fanı bağlayıcısı (3-pin)
- 1 x 24 pin ATX güç bağlayıcısı
- 1 x 8 pin 12V güç bağlayıcısı (Yüksek Yoğunluklu Güç Konektörü)
- 1 x SLI/XFire güç bağlayıcısı
- 1 x Ön panel ses bağlayıcısı
- 1 x SPDIF Çıkış bağlayıcısı
- 2 x USB 2.0 bağlantısı (4 USB 2.0 bağlantı noktasını destekler)
- 1 x Dikey Tip A USB 3.0
- 1 x Etron EJ188 USB 3.0 bağlantısı (2 USB 3.0 bağlantı noktasını destekler)

### BIOS Özellikleri

- GUI Desteği ile 32Mb AMI UEFI Legal BIOS
- "Tak Çalıştır"ı destekler
- ACPI 1.1 Uyumluluğu Uyandırma Olayları
- Jumpersız ayarlamayı destekler
- SMBIOS 2.3.1 Desteği
- CPU, DRAM, NB, HT, CPU VDDA, PCIE VDDA, CPU NB Voltaj Çoklu Ayarı

**Destek  
CD'si**

- Sürücüler, Yardımcı Yazılımlar, Antivirüs Yazılımı (Deneme Sürümü), Google Chrome Tarayıcı ve Araç Çubuğu, Start8 (30 günlük deneme), XSplit, Killer Network Manager

**Donanım  
İzleyici**

- CPU/Kasa Sıcaklığı Tespiti
- CPU/Kasa/Güç Fanı Devirölçer
- CPU/Kasa Sessiz Fan (Kasa Fan Hızının CPU Sıcaklığına Göre Otomatik olarak Ayarlanmasını Sağlar)
- CPU/Kasa Fanı Çoklu Hız Kontrolü
- Voltaj İzleme: +12V, +5V, +3,3V, CPU Vcore

**OS**

- Microsoft® Windows® 10 64-bit / 8.1 32-bit / 8.1 64-bit / 8 32-bit / 8 64-bit / 7 32-bit / 7 64-bit

**Belgeler**

- FCC, CE, WHQL
- ErP/EuP için hazır (ErP/EuP için hazır güç beslemesi gereklidir)

\* Detaylı ürün bilgisi için, lütfen web sitemizi ziyaret edin: <http://www.asrock.com>



Lütfen, BIOS ayarlarını düzenleme, Bağımsız Hız Aşırtma Teknolojinin uygulanması ya da üçüncü kişilerin hız aşırtma araçlarının kullanılması da dahil olmak üzere tüm hız aşırtma işlemlerinin belirli bir risk taşıdığını unutmayın. Hız aşırtma, sisteminizin dayanıklılığını etkileyebilir, hatta sisteminizde yer alan bileşen ve aygıtlara zarar verebilir. Bunu riski ve masrafları size ait olmak üzere gerçekleştirilmelidir. Hız aşırtmadan doğabilecek zararlar konusunda sorumlu olmayacağız.



1. 2450/2100MHz bellek hızı çalıştırdığımız AM3/AM3+ CPU'ya göre desteklenir. DDR3 2450/2100 bellek modülünü bu anakartta çalıştırmak istiyorsanız, uyumlu bellek modülleri için lütfen web sitemizdeki bellek destek listesine bakın.  
ASRock web sitesi: <http://www.asrock.com>
2. İşletim sistemi kısıtlaması nedeniyle, Windows® 8 / 7 altında sistem kullanımı için ayrımak için gerçek bellek boyutu 4 GB'den az olabilir. 64-bit CPU'lu Windows® OS için bu tür bir sınırlama yoktur. Windows® tarafından kullanılmayan bellekten faydalanmak için ASRock XFast RAM'i kullanabilirsiniz.

## 1.3 Bağlantı Teli Kurulumu

Çizim, bağlantı tellerinin kurulumunu göstermektedir. Tel kapağı, pimlerin üzerine yerleştirildiğinde, tel "Kısa" olur. Pimlerin üzerinde tel kapağı bulunmadığında, tel "Kısa" olur. Çizim, pin1 ve pin2 alanları "Kısa" olan ve bu iki pim üzerinde bir bağlantı teli kapağı bulunan 3-pin bağlantı telini göstermektedir.

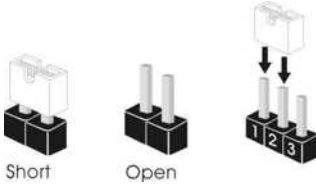

CMOS'u Temizle Bağlantı  
Teli  
(CLRCMOS1)  
(bkz. sf.1, No. 21)



CLRCMOS1, CMOS verilerini temizlememizi sağlar. Sistem parametrelerini temizlemek ve varsayılan kurulum ayarlarına sıfırlamak için, lütfen bilgisayarı kapatın ve güç kablosunu güç beslemesinden çekin. 15 saniye bekledikten sonra, CLRCMOS1 üzerindeki pin2 ve pin3'ü 5 saniye boyunca kısaltmak için bir bağlantı teli kullanın. Ancak, CMOS'u lütfen BIOS'u güncelledikten hemen sonra temizlemeyin. BIOS'u güncelledikten hemen sonra CMOS'u temizlemeniz gerekirse, önce sistemi başlatın ve ardından CMOS temizleme işlemi öncesinde yeniden kapatın. Lütfen, parola, tarih, saat ve varsayılan kullanıcı profilinin yalnızca CMOS bataryası çıkarıldığında temizleneceğini unutmayın.

## 1.4 Ekli Bağlantılar ve Bağlayıcılar



Ekli bağlantılar ve bağlayıcılar bağlantı teli değildir. Bağlantı teli kapaklarını bu bağlantı ve bağlayıcılar üzerine yerleştirmeyin. Bağlantı teli kapaklarının bağlantılar ile bağlayıcılar üzerine yerleştirilmesi, anakarta kalıcı hasar verebilir.

Sistem Paneli Bağlantısı  
(9-pin PANEL1)  
(bkz sf.1, No. 20)

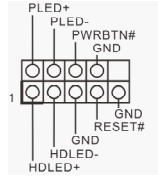

Güç anahtarını bağlayın, kasa üzerindeki anahtar ile sistem durumu belirtecini aşağıdaki pim düzenine göre sıfırlayın. Kabloları bağlarken pozitif ve negatif pimleri not edin.



### PWRBTN (Güç Anahtarı):

Güç anahtarını kasa ön paneline bağlayın. Güç anahtarını kullanarak sistemin hangi yöne hareketle kapanacağını seçebilirsiniz.

### RESET (Sıfırlama Anahtarı):

Sıfırlama anahtarını kasa ön paneline bağlayın. Bilgisayarın kilitlemesi ve normal şekilde yeniden başlatılmaması halinde reset (sıfırla) düğmesine basın.

### PLED (Sistem Gücü LED):

Güç durumu belirtecini kasa ön paneline bağlayın. Sistem çalışırken LED ışığı yanacaktır. Sistem S1/S3 uykuya girerken LED ışığı yanıp söner. Sistem S4 uykuya girerken ya da kapalıyken (S5) LED ışık kapanır.

### HDLED (Sabit Disk Aktivitesi LED):

Sabit Disk Aktivitesi LED'i kasanın ön paneline bağlayın. Sabit sürücü veri okur ya da yazarken LED ışığı yanar.

Ön panel tasarımı kasaya göre değişiklik gösterebilir. Bir ön panel modülü, temel olarak bir güç anahtarı, sıfırlama anahtarı, güç LED'i, sabit sürücü aktivitesi LED'i, hoparlör gibi birimlerden oluşur. Kasanızın ön panel modülünü bu bağlantıya takmadan önce, kablo düzenlemeleri ile pin düzenlemelerinin düzgün şekilde yapıldığından emin olun.

Güç LED Bağlantısı  
(3-pin PLED1)  
(bkz. sf.1, No. 18)



Sistemin güç durumunun belirtilmesi için lütfen güç LED'ini bu bağlantıya takın.

Seri ATA3 Bağlayıcıları  
(SATA3\_1:  
bkz. sf.1, No. 17)  
(SATA3\_2:  
bkz. sf.1, No. 16)  
(SATA3\_3:  
bkz. sf.1, No. 14)  
(SATA3\_4:  
bkz. sf.1, No. 15)  
(SATA3\_5:  
bkz. sf.1, No. 12)



Bu beş SATA3 bağlayıcısı, veri aktarım hızı 6,0 Gb/sn'ye kadar olan dahili depolama aygıtları için tasarlanmış SATA vericilerini destekler.

USB 2.0 Bağlantıları  
(9-pin USB6\_7)  
(bkz. sf.1, No. 9)  
(9-pin USB8\_9)  
(bkz. sf.1, No. 8)

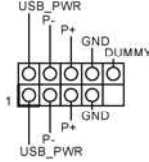

Bu anakart üzerinde, I/O paneli üzerindeki altı USB 2.0 bağlantı noktasının yanı sıra, iki adet bağlantı bulunmaktadır. Her USB 2.0 bağlantısı, iki adet bağlantı noktasını destekleyebilir.

USB 3.0 Bağlantıları  
(19-pin USB3\_5\_6)  
(bkz. sf.1, No. 10)

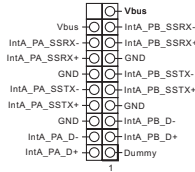

(USB3\_7)  
(bkz. sf.1, No. 11)



Bu anakart üzerinde, G/Ç panelindeki dört tane USB 3.0 bağlantı noktasının yanı sıra bir adet bağlantı noktası bulunmaktadır. Her USB 3.0 bağlantısı, iki adet bağlantı noktasını destekleyebilir.

### Ön Panel Ses Bağlantısı (9-pin HD\_AUDIO1) (bkz. sf.1, No. 27)

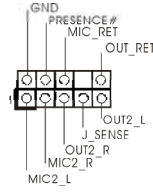

Bu bağlantı, ses aygıtlarının ön ses paneline bağlanması içindir.



- Yüksek Tanımlı Ses, Jak Algılama özelliğini destekler, ancak bu işlevin düzgün çalışabilmesi için kasa üzerindeki panel kablosunun HDA işlevini desteklemesi gerekmektedir. Sisteminizi kurarken, lütfen kılavuzumuzdaki talimatlar ile kasa kılavuzundaki talimatları izleyin.
- Bir AC'97 ses paneli kullanıyorsanız, lütfen bu paneli aşağıdaki adımları izleyerek ön panel ses bağlantısına takın:
  - Mic\_IN (MIC)'i MIC2\_L'ye bağlayın.
  - Audio\_R (RIN)'i OUT2\_R'ye ve Audio\_L (LIN)'yi OUT2\_L'ye bağlayın.
  - Topraklamayı (GND) Topraklamaya (GND) bağlayın.
  - MIC\_RET ve OUT\_RET, yalnızca HD ses paneli içindir. Bunları AC'97 ses panelinden bağlamanıza gerek yoktur.
  - Ön mikrofonu etkinleştirmek için Realtek Denetim panelinde yer alan "FrontMic (Ön Mikrofon)" Sekmesine tıklayın ve "Recording Volume (Kayıt Sesi Düzeyi)" değerini ayarlayın.

### Kasa Hoparlör Bağlantısı (4-pin SPEAKER1) (bkz sf.1, No. 19)

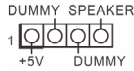

Lütfen kasa hoparlörünü bu bağlantıya takın.

### Kasa ve Güç Fanı Bağlayıcıları (4-pin CHA\_FAN1) (bkz sf.1, No. 29)

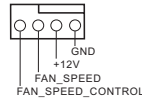

Lütfen fan kablolarını fan bağlayıcılarına takın ve siyah teli topraklama pinine bağlayın.

### (3-pin CHA\_FAN2) (bkz sf.1, No. 1)

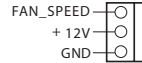

### (3-pin CHA\_FAN3) (bkz sf.1, No. 22)



### (3-pin PWR\_FAN1) (bkz sf.1, No. 28)



### CPU Fan Bağlayıcıları

(4-pin CPU\_FAN1)

(bkz sf.1, No. 3)

(3-pin CPU\_FAN2)

(bkz sf.1, No. 4)

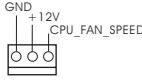
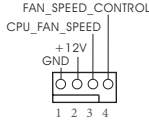

Bu anakart, 4-Pin CPU fan (Sessiz Fan) bağlayıcısı sağlamaktadır. 3-Pin CPU fan bağlamak istiyorsanız, lütfen Pin 1-3'ü kullanın.

### ATX Güç Bağlayıcısı

(24-pin ATXPWR1)

(bkz. sf.1, No. 7)

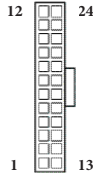

Bu anakart, 24-pin ATX güç bağlayıcısı sağlamaktadır. 20-pin ATX güç beslemesi kullanmak için, lütfen Pin 1 ve Pin13'e bağlayın.

### ATX 12V Güç Bağlayıcısı

(8-pin ATX12V1)

(bkz. sf.1, No. 2)

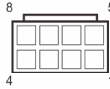

Bu anakart, 8-pin ATX 12V güç bağlayıcısı sağlamaktadır. 4-pin ATX güç beslemesi kullanmak için, lütfen Pin 1 ve Pin5'e bağlayın.

### SLI/XFIRE Güç

Bağlayıcısı

(4 pinli SLI/XFIRE\_PWR1)

(bkz. sf.1, No. 23)



üç grafik kartı bu anakarta takılıyken lütfen bu bağlayıcısı sabit disk güç bağlayıcısına bağlayın.

### Kızılötesi Modül

Bağlantısı

(5-pin IR1)

(bkz. sf.1, No. 24)

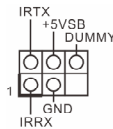

Bu bağlantı, isteğe bağlı olarak kızılötesi modülden bir kablosuz bağlantı aktarımı ile alımını da destekler.

Seri Bağlantı Noktası  
Bağlantısı  
(9-pin COM1)  
(bkz. sf.1, No. 25)

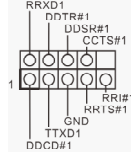

Bu COM1 bağlantısı seri bağlantı yuvası modülünü destekler.

SPDIF Çıkış Bağlayıcısı  
(2-pin SPDIF\_OUT1)  
(bkz. sf.1, No. 26)



Lütfen kablo ile bu bağlantıya bir HDMI VGA kartının SPDIF\_OUT bağlayıcı takın.

TPM Bağlantısı  
(17-pin TPMS1)  
(bkz. sf.1, No. 13)

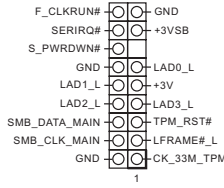

Bu bağlayıcı, anahtarlar, dijital sertifikalar, parolalar ve verileri güvenli bir şekilde saklama özelliği bulunan Güvenilir Platform Modülü (TPM) sistemini destekler. TPM sistemleri, aynı zamanda ağ güvenliğinin artırılması, dijital kimliklerin korunması ve platform bütünlüğünün sağlanmasına da yardımcıdır.

# 1 개요

ASRock FatalIty 990FX Killer 시리즈 마더보드를 구입해 주셔서 감사합니다. 이 마더보드는 ASRock의 일관되고 엄격한 품질관리 하에 생산되어 신뢰성이 우수합니다. 품질과 내구성에 대한 ASRock의 기준에 부합하는 우수한 성능과 견고한 설계를 제공합니다.



마더보드 규격과 BIOS 소프트웨어를 업데이트할 수도 있기 때문에, 이 설명서의 내용은 예고 없이 변경될 수 있습니다. 이 설명서가 변경될 경우, 업데이트된 버전은 ASRock의 웹사이트에서 추가 통지 없이 제공됩니다. 이 마더보드와 관련하여 기술적 지원이 필요한 경우, 당사의 웹사이트를 방문하여 사용 중인 모델에 대한 구체적인 정보를 구하십시오. ASRock의 웹사이트에서는 최신 VGA 카드와 CPU 지원 목록도 찾을 수 있습니다. ASRock 웹사이트 <http://www.asrock.com>.

## 1.1 포장 내용물

- ASRock FatalIty 990FX Killer 시리즈 마더보드 (ATX 폼 팩터)
- ASRock FatalIty 990FX Killer 시리즈 간편 설치 안내서
- ASRock FatalIty 990FX Killer 시리즈 지원 CD
- 시리얼 ATA (SATA) 데이터 케이블 4 개 (선택 품목)
- I/O 패널 실드 1 개
- ASRock SLI\_Bridge\_2S 카드 1 개
- M.2\_SSD (NGFF) 소켓 3 나사 1 개

## 1.2 규격

### 플랫폼

- ATX 폼 팩터
- 프리미엄 골드 콘덴서 구조 (100% 일본산 고품질 전도성 폴리머 콘덴서)

### A- 스타일

- Purity Sound™

### 게이밍 갑옷

#### CPU 전원

- 고밀도 전원 커넥터

#### VGA 카드

- VGA PCIe 슬롯에 15  $\mu$  Gold Finger 장착 (PCIe2/PCIe3)
- SLI/XFire 전원 커넥터

#### 인터넷

- Qualcomm® Atheros® Killer™ LAN

#### 오디오

- Purity Sound™

### CPU

- Socket AM3+ 프로세서에 대한 지원
- Socket AM3 프로세서에 대한 지원 : AMD Phenom™ II X6 / X4 / X3 / X2 (920/940 제외) / Athlon II X4 / X3 / X2 / Sempron 프로세서
- 8- 코어 CPU 지원
- UCC (Unlock CPU Core) 지원
- Digi 전원 구조
- 고급 8 + 2 전원 위상 디자인
- 최대 140W 까지 CPU 지원
- AMD의 Cool 'n' Quiet™ 기술 지원
- FSB 2600 MHz (5.2 GT/s)
- 언타이드 오버클러킹 (Untied Overclocking) 기술 지원
- 하이퍼 트랜스포트 3.0 (HT 3.0) 기술 지원

### 칩세트

- 노스브릿지 : AMD 990FX
- 사우스 브릿지 : AMD SB950

### 메모리

- 듀얼 채널 DDR3 메모리 기술
- DDR3 DIMM 슬롯 4 개
- DDR3 2450(OC)/2100(OC)/1600/1333/1066 비 -ECC, 비버퍼링 메모리 지원 ( 주의 1 참조 )

- 시스템 메모리 최대 용량 : 64GB ( 주의 2 참조 )
- Intel® Extreme Memory Profile (XMP)1.3/1.2 지원
- AMD 메모리 프로파일 기술 (AMP) 지원

### 확장 슬롯

- PCI Express 2.0 x16 슬롯 3 개 (PCIe2/PCIe3: x16 모드 ; PCIe5: x4 모드 )
- PCI Express 2.0 x1 슬롯 2 개
- AMD Quad CrossFireX™, 3-Way CrossFireX™ 및 CrossFireX™ 지원
- NVIDIA® Quad SLI™ 및 SLI™ 지원

### 오디오

- 콘텐츠 보호를 이용한 7.1 CH HD 오디오 지원 (Realtek ALC1150 오디오 코덱 )
- 프리미엄 Blu-ray 오디오 지원
- Purity Sound™
  - 115dB SNR DAC 및 디퍼렌셜 증폭기 지원
  - TI® NE5532 ( 최대 600 옴의 프리미엄 헤드셋 증폭기 지원 )
  - 다이렉트 드라이브 기술
  - EMI 차폐 커버
  - PCB 절연 차폐
- DTS 연결 지원

### LAN

- PCIe x1 Gigabit LAN 10/100/1000 Mb/s
- Qualcomm® Atheros® Killer™ E2200 시리즈
- Wake-On-LAN 지원
- 절전형 이더넷 802.3az 지원
- PXE 지원

### 후면 패널 I/O

- PS/2 마우스 포트 1 개
- PS/2 키보드 포트 1 개
- 광학 SPDIF 출력 포트 1 개
- USB 2.0 포트 5 개
- Fatal1ty 마우스 포트 1 개 (USB 2.0)
- USB 3.0 포트 4 개 (ASMedia Hub)
- eSATA3 커넥터 1 개
- LED 장착 RJ-45 LAN 포트 1 개 (ACT/LINK LED 및 SPEED LED)

- HD 오디오 잭 : 후면 스피커 / 중앙 / 베이스 / 라인 입력 / 전면 스피커 / 마이크

**저장 장치**

- SATA3 6.0 Gb/s 커넥터 5 개가 RAID (RAID 0, RAID 1, RAID 0+1, JBOD 및 RAID 5), NCQ, AHCI 및 “핫 플러그”를 지원
- M.2\_SSD (NGFF) 소켓 3 1 개, Gen2 최대 2 (10 Gb/s) 개까지 M.2 SATA3 6.0 Gb/s 모듈 및 M.2 PCI Express 모듈 지원 (M.2\_SSD (NGFF) 소켓 3 은 eSATA3 커넥터와 공유됨 )

**커넥터**

- IR 헤더 1 개
- COM 포트 헤더 1 개
- TPM 헤더 1 개
- 전원 LED 헤더 1 개
- CPU 팬 커넥터 2 개 (1 x 4 핀, 1 x 3 핀)
- 새시 팬 커넥터 3 개 (1 x 4 핀, 2 x 3 핀)
- 전원 팬 커넥터 1 개 (3 핀)
- 24 핀 ATX 전원 커넥터 1 개
- 8 핀 12V 전원 커넥터 1 개 ( 고밀도 전원 커넥터 )
- SLI/XFire 전원 커넥터 1 개
- 전면 패널 오디오 커넥터 1 개
- SPDIF 출력 커넥터 1 개
- USB 2.0 헤더 2 개 (USB 2.0 포트 4 개 지원)
- 수직 타입 A USB 3.0 1 개
- Etron EJ188 USB 3.0 헤더 1 개 (USB 3.0 포트 2 개 지원)

**BIOS****기능**

- GUI 지원 32Mb AMI UEFI Legal BIOS
- “플러그 앤 플레이”지원
- ACPI 1.1 준수 웨이크 업 이벤트
- 점퍼 프리 지원
- SMBIOS 2.3.1 지원
- CPU, DRAM, NB, HT, CPU VDDA, PCIE VDDA, CPU NB 전압 다중 조정

**지원 CD**

- 드라이버, 유틸리티, 백신 소프트웨어 ( 시험판 ), Google Chrome 브라우저 및 툴바, Start8 (30 일 시험판), XSplit, Killer Network Manager

**하드웨어  
모니터**

- CPU/ 샤페 온도 감지
- CPU/ 샤페 / 전원 팬 타코미터
- CPU/ 샤페 저소음 팬 (CPU 온도에 의한 샤페 팬 속도 자동 조정)
- CPU/ 샤페 팬 다중 속도 조절
- 전압 모니터링 : +12V, +5V, +3.3V, CPU Vcore

**OS**

- Microsoft® Windows® 10 64 비트 / 8.1 32 비트 / 8.1 64 비트 / 8 32 비트 / 8 64 비트 / 7 32 비트 / 7 64 비트

**인증**

- FCC, CE, WHQL
- ErP/EuP 사용 가능 (ErP/EuP 사용 가능 전원공급장치 필요)

\* 자세한 제품 정보에 대해서는 당사 웹사이트를 참조하십시오 : <http://www.asrock.com>



BIOS 설정을 조정하거나 *Untied Overclocking Technology* 를 적용하거나 타업체의 오버클로킹 도구를 사용하는 것을 포함하는 오버클로킹에는 어느 정도의 위험이 따른다는 것을 유념하십시오. 오버클로킹은 시스템 안정성에 영향을 주거나 심지어 시스템의 구성 요소와 장치에 손상을 입힐 수도 있습니다. 오버클로킹은 사용자 스스로 위험과 비용을 감수하고 해야 합니다. 당사는 오버클로킹에 의해 발생할 수 있는 손상에 대해서 책임이 없습니다.



1. 2450/2100MHz 메모리 속도의 지원 여부는 채택된 AM3/AM3+ CPU 에 따라 결정됩니다. 이 마더보드에 DDR3 2450/2100 메모리 모듈을 채택하려는 경우 당사 웹사이트의 메모리 지원 목록에서 호환 가능한 메모리 모듈을 검색하십시오. ASRock 웹사이트 : <http://www.asrock.com>
2. 운영 체제 한계 때문에 Windows\* 8 / 7 에서 시스템 용도로 예약된 실제 메모리 크기는 4 GB 이하일 수 있습니다. 64 비트 CPU 와 Windows\* OS 의 경우 그런 한계가 없습니다. ASRock XFast RAM 을 사용하여 Windows\* 가 사용할 수 없는 메모리를 이용할 수 있습니다.

### 1.3 점퍼 설정

그림은 점퍼를 어떻게 설정하는지 보여줍니다. 점퍼 캡을 핀에 씌우면 점퍼가 “단락”됩니다. 점퍼 캡을 핀에 씌우지 않으면 점퍼가 “단선”됩니다. 그림은 3 핀 점퍼를 보여주며 핀 1 과 핀 2 는 점퍼 캡을 씌울 때 “단락”됩니다.

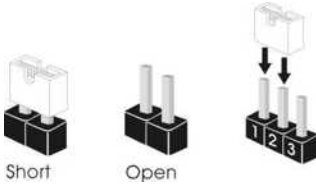

Clear CMOS 점퍼

(CLR CMOS1)

(1 페이지, 21 번 항목 참조)

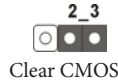

CLR CMOS1 을 사용하여 CMOS 에 저장된 데이터를 지울 수 있습니다 . 시스템 파라미터를 지우고 기본 설정으로 초기화하려면 컴퓨터를 끄고 전원 코드를 전원 공급장치에서 빼십시오 . 15 초 동안 기다린 후 점퍼 캡을 사용하여 CLR CMOS1 의 핀 2 와 핀 3 을 5 초 동안 단락시키십시오 . 그러나 BIOS 업데이트 직후에는 CMOS 를 삭제하지 마십시오 . BIOS 업데이트를 완료한 직후 CMOS 를 지워야 할 경우 , 우선 시스템을 부팅한 후 바이오스 업데이트를 종료한 다음 CMOS 지우기 작업을 해야 합니다 . CMOS 배터리를 제거할 경우에만 암호 , 날짜 , 시간 , 사용자 기본 프로파일이 지워집니다 .

## 1.4 온보드 헤더 및 커넥터



온보드 헤더와 커넥터는 점퍼가 아닙니다. 점퍼 캡을 온보드 헤더와 커넥터에 씌우지 마십시오. 점퍼 캡을 온보드 헤더와 커넥터에 씌우면 마더보드가 영구적으로 손상됩니다.

시스템 패널 헤더  
(9 핀 PANEL1)  
(1 페이지, 20 번  
항목 참조)

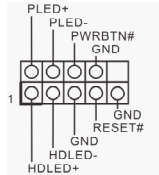

새시의 전원 스위치, 리셋 스위치, 시스템 상태 표시등을 아래의 핀 할당에 따라 이 헤더에 연결합니다. 케이블을 연결하기 전에 양극 핀과 음극 핀을 기록합니다.



**PWRBTN( 전원 스위치 ):**

새시 전면 패널의 전원 스위치에 연결합니다. 전원 스위치를 이용해 시스템을 끄는 방법을 구성할 수 있습니다.

**RESET( 리셋 스위치 ):**

새시 전면 패널의 리셋 스위치에 연결합니다. 컴퓨터가 정지하고 정상적 재시작을 수행하지 못할 경우 리셋 스위치를 눌러 컴퓨터를 재시작합니다.

**PLED( 시스템 전원 LED ):**

새시 전면 패널의 전원 상태 표시등에 연결합니다. 시스템이 작동하고 있을 때는 LED가 켜져 있습니다. 시스템이 S1/S3 대기 상태에 있을 때는 LED가 계속 깜박입니다. 시스템이 S4 대기 상태 또는 전원 꺼짐 (S5) 상태에 있을 때는 LED가 꺼져 있습니다.

**HDLED( 하드 드라이브 동작 LED ):**

새시 전면 패널의 하드 드라이브 동작 LED에 연결합니다. 하드 드라이브가 데이터를 읽거나 쓰고 있을 때 LED가 켜져 있습니다.

전면 패널 디자인은 새시별로 다를 수 있습니다. 전면 패널 모듈은 주로 전원 스위치, 리셋 스위치, 전원 LED, 하드 드라이브 동작 LED, 스피커 등으로 구성되어 있습니다. 새시 전면 패널 모듈을 이 헤더에 연결할 때 와이어 할당과 핀 할당이 정확히 일치하는지 확인합니다.

전원 LED 헤더  
(3 핀 PLED1)  
(1 페이지, 18 번 항목 참조)



시스템 전원 상태를 나타내려면 새시 전원 LED를 이 헤더에 연결하십시오.

시리얼 ATA3 커넥터  
(SATA3\_1:  
1 페이지, 17 번 항목 참조)  
(SATA3\_2:  
1 페이지, 16 번 항목 참조)  
(SATA3\_3:  
1 페이지, 14 번 항목 참조)  
(SATA3\_4:  
1 페이지, 15 번 항목 참조)  
(SATA3\_5:  
1 페이지, 12 번 항목 참조)

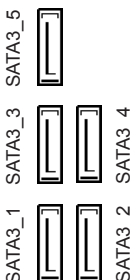

이들 5 개의 SATA3 커넥터는 최대 6.0 Gb/s 데이터 전송 속도를 제공하는 내부 저장 장치용 SATA 데이터 케이블을 지원합니다.

USB 2.0 헤더  
(9 핀 USB6\_7)  
(1 페이지, 9 번 항목 참조)  
(9 핀 USB8\_9)  
(1 페이지, 8 번 항목 참조)

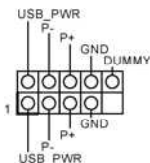

I/O 패널에 USB 2.0 포트 6 개가 탑재되어 있을 뿐 아니라 마더보드에 헤더 두 개가 탑재되어 있습니다. 각 USB 2.0 헤더는 포트 두 개를 지원할 수 있습니다.

USB 3.0 헤더  
(19 핀 USB3\_5\_6)  
(1 페이지, 10 번 항목 참조)

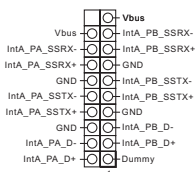

(USB3\_7)  
(1 페이지, 11 번 항목 참조)



I/O 패널에 탑재된 네 개의 USB 3.0 포트 이외에도 이 마더보드에는 헤더 한 개와 포트 한 개가 탑재되어 있습니다.

각 USB 3.0 헤더는 포트 두 개를 지원할 수 있습니다.

전면 패널 오디오 헤더  
(9 핀 HD\_AUDIO1)  
(1 페이지, 27 번 항목 참조)

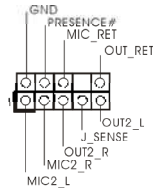

이 헤더는 오디오 장치를 전면 오디오 패널에 연결하는 데 사용됩니다.



1. 고음질 오디오는 잭 감지를 지원하지만 올바르게 작동하려면 새시의 패널 와이어가 HDA를 지원해야 합니다. 설명서 및 새시 설명서에 나와 있는 지침을 따라 시스템을 설치하십시오.
2. AC'97 오디오 패널을 사용할 경우 아래와 같은 절차를 따라 전면 패널 오디오 헤더에 설치하십시오:
  - A. Mic\_IN (MIC)을 MIC2\_L에 연결합니다.
  - B. Audio\_R (RIN)을 OUT2\_R에 연결하고 Audio\_L (LIN)을 OUT2\_L에 연결합니다.
  - C. 접지 (GND)를 접지 (GND)에 연결합니다.
  - D. MIC\_RET 및 OUT\_RET는 HD 오디오 패널에만 사용됩니다. AC'97 오디오 패널용으로 연결할 필요가 없습니다.
  - E. 전면 마이크를 활성화하려면 Realtek 제어판에서 "FrontMic" 탭으로 가서 "Recording Volume(녹음 볼륨)"을 조정합니다.

새시 스피커 헤더  
(4 핀 SPEAKER1)  
(1 페이지, 19 번 항목 참조)

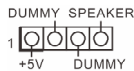

새시 스피커를 이 헤더에 연결하십시오.

새시 및 전원 팬 커넥터  
(4 핀 CHA\_FAN1)  
(1 페이지, 29 번 항목 참조)

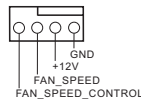

팬 케이블을 팬 커넥터에 연결하고 검은색 와이어를 접지핀에 연결하십시오.

(3 핀 CHA\_FAN2)  
(1 페이지, 1 번 항목 참조)

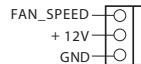

(3 핀 CHA\_FAN3)  
(1 페이지, 22 번 항목 참조)



(3 핀 PWR\_FAN1)  
(1 페이지, 28 번 항목 참조)



중  
서  
하

### CPU 팬 커넥터

(4 핀 CPU\_FAN1)

(1 페이지, 3 번 항목 참조)

(3 핀 CPU\_FAN2)

(1 페이지, 4 번 항목 참조)

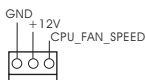
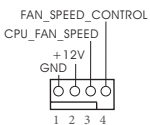

이 마더보드에는 4 핀 CPU 팬 (저소음 팬) 커넥터가 탑재되어 있습니다. 3 핀 CPU 팬을 연결하려는 경우 핀 1-3 에 연결하십시오.

### ATX 전원 커넥터

(24 핀 ATXPWR1)

(1 페이지, 7 번 항목 참조)

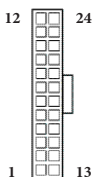

이 마더보드에는 24 핀 ATX 전원 커넥터가 탑재되어 있습니다. 20 핀 ATX 전원공급장치를 사용하려면 핀 1 과 핀 13 을 따라 연결하십시오.

### ATX 12V 전원 커넥터

(8 핀 ATX12V1)

(1 페이지, 2 번 항목 참조)

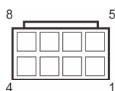

이 마더보드에는 8 핀 ATX 12V 전원 커넥터가 탑재되어 있습니다. 4 핀 ATX 전원공급장치를 사용하려면 핀 1 과 핀 5 을 따라 연결하십시오.

### SLI/XFIRE 전원 커넥터

(4 핀 SLI/XFIRE\_PWR1)

(1 페이지, 23 번 항목 참조)



이 마더보드에 그래픽 카드 세 개를 설치할 때 이 커넥터를 하드 디스크 전원 커넥터와 연결하십시오.

### 적외선 모듈 헤더

(5 핀 IR1)

(1 페이지, 24 번 항목 참조)

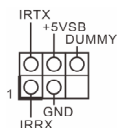

이 헤더는 선택 품목인 무선 송수신 적외선 모듈을 지원합니다.

시리얼 포트 헤더  
(9 핀 COM1)  
(1 페이지, 25 번 항목 참조)

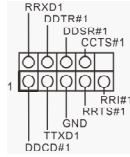

이 COM1 헤더는 시리얼 포트 모듈을 지원합니다.

SPDIF 출력 커넥터  
(2 핀 SPDIF\_OUT1)  
(1 페이지, 26 번 항목 참조)



HDMI VGA 카드의 SPDIF\_OUT 커넥터를 케이블로 이 헤더에 연결하십시오.

TPM 헤더  
(17 핀 TPMS1)  
(1 페이지, 13 번 항목 참조)

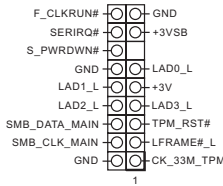

이 커넥터는 키, 디지털 인증서, 암호 및 데이터를 안전하게 보관할 수 있는 TPM(Trusted Platform Module) 시스템을 지원합니다. TPM 시스템은 네트워크 보안을 강화하고, 디지털 신원을 보호하며 플랫폼 무결성을 유지합니다.

공  
서  
회

# 1 はじめに

アスロックの一貫した厳格な品質管理の下で製造された信頼性の高いマザーボードであるアスロック FatalIty 990FX Killer シリーズマザーボードをお買い上げいただきありがとうございます。アスロックの品質と耐久性の取り組みに準拠した堅牢な設計を持つ、優れたパフォーマンスを提供します。



マザーボードの仕様と BIOS ソフトウェアは更新されることがあるため、このマニュアルの内容は予告なしに変更することがあります。このマニュアルの内容に変更があった場合には、更新されたバージョンは、予告なくアスロックのウェブサイトから入手できるようになります。このマザーボードに関する技術的なサポートが必要な場合には、ご使用のモデルについての詳細情報を、当社のウェブサイトで参照ください。アスロックのウェブサイトでは、最新の VGA カードおよび CPU サポート一覧もご覧になれます。アスロックウェブサイト <http://www.asrock.com>。

## 1.1 パッケージの内容

- アスロック FatalIty 990FX Killer シリーズマザーボード (ATX フォームファクター)
- アスロック FatalIty 990FX Killer シリーズクイックインストールガイド
- アスロック FatalIty 990FX Killer シリーズサポート CD
- 4 x シリアル ATA (SATA) データケーブル (オプション)
- 1 x I/O パネルシールド
- 1 x アスロック SLI\_Bridge\_2S カード
- 1 x M.2\_SSD (NGFF) ソケット 3 用ねじ

## 1.2 仕様

### プラットフォーム

- ATX フォームファクター
- プレミアムゴールドコンデンサー設計 (100% 日本製の高品質導電性高分子コンデンサー)

### A スタイル

- Purity Sound™

### ゲーミングのための武装

#### CPU 電源

- 高密度電源コネクタ

#### VGA カード

- VGA PCIe スロット (PCIe2/PCIe3) に 15μ のゴールドフィンガー
- SLI/XFire 電源コネクタ

#### インターネット

- Qualcomm® Atheros® Killer™ LAN

#### 音声

- Purity Sound™

### CPU

- Socket AM3+ プロセッサのサポート
- Socket AM3 プロセッサのサポート :AMD Phenom™ II X6 / X4 / X3 / X2(920 / 940 を除く) / Athlon II X4 / X3 / X2 / Sempron プロセッサ
- 8-Core CPU 搭載
- UCC (Unlock CPU Core) をサポート
- デジタル電源設計
- 高度な 8 + 2 電源位相設計
- 140W まで CPU をサポート
- AMD 社 Cool 'n' Quiet™ をサポート
- FSB 2600 MHz (5.2 GT/s)
- Untied Overclocking をサポート
- Hyper-Transport 3.0 (HT 3.0) をサポート

### チップセット

- ノースブリッジ : AMD 990FX
- サウスブリッジ : AMD SB950

### メモリ

- デュアルチャンネル DDR3 メモリテクノロジー
- 4 x DDR3 DIMM スロット
- DDR3 2450(OC)/2100(OC)/1600/1333/1066 ECC なし、アンパツファードメモリをサポート (注意 1 を参照)

- システムメモリの最大容量：64GB（注意 2 を参照）
- Intel® エクストリームメモリプロファイル（XMP）1.3/1.2 をサポート
- AMD メモリプロファイルテクノロジー（AMP）に対応

## 拡張スロット

- 3 x PCI Express 2.0 x16 スロット（PCIe2/PCIe3：x16 モード、PCIe5：x4 モード）でトリプル
- 2 x PCI Express 2.0 x1 スロット
- AMD Quad CrossFireX™、3-Way CrossFireX™、CrossFireX™ をサポート
- NVIDIA® Quad SLI™ および SLI™ をサポート

## 音声

- 7.1 CH HD オーディオ、コンテンツプロテクション付き（Realtek ALC1150 オーディオコーデック）
- プレミアムブルーレイオーディオサポート
- Purity Sound™ をサポート
  - 差動アンプによる 115dB SNR DAC
  - TI® NE5532（最大 600 Ω のプレミアムヘッドセットアンプをサポート）
  - ダイレクトドライブテクノロジー
  - EMI シールドカバー
  - PCB 分離シールド
- DTS 接続をサポート

## LAN

- PCIe x1 ギガビット LAN 10/100/1000 Mb/ 秒
- Qualcomm® Atheros® Killer™ E2200 シリーズ
- ウェイクオンランをサポート
- エネルギー効率のよいイーサネット 802.3az をサポート
- PXE をサポート

## リアパネル I/O

- 1 x PS/2 マウスポート
- 1 x PS/2 キーボードポート
- 1 x 光 SPDIF 出力ポート
- 5 x USB 2.0 ポート
- 1 x Fatal1ty マウスポート（USB 2.0）
- 4 x USB 3.0 ポート（ASMedia ハブ）
- 1 x eSATA3 コネクタ

- LED 付き 1 x RJ-45 LAN ポート (ACT/LINK LED と SPEED LED)
- HD オーディオジャック: リアスピーカー / センター / バス / ラインイン / フロントスピーカー / マイク

## ストレージ

- 5 x SATA3 6.0 Gb/ 秒コネクタ、RAID (RAID 0、RAID 1、RAID 0+1、JBOD、RAID 5)、NCQ、AHCI、「ホットプラグ」をサポート
- 1 x M.2\_SSD (NGFF) ソケット 3、M.2 SATA3 6.0 Gb/s モジュールおよび M.2 PCI Express モジュール (最大 Gen2 x2、10 Gb/s) をサポート (M.2\_SSD (NGFF) ソケット 3 は eSATA3 コネクタと共有)

## コネクタ

- 1 x IR ヘッダー
- 1 x COM ポートヘッダー
- 1 x TPM ヘッダー
- 1 x 電源 LED ヘッダー
- 2 x CPU ファインコネクタ (1 x 4 ピン、1 x 3 ピン)
- 3 x シャーシファンコネクタ (1 x 4 ピン、2 x 3 ピン)
- 1 x 電源ファンコネクタ (3 ピン)
- 1 x 24 ピン ATX 電源コネクタ
- 1 x 8 ピン 12V 電源コネクタ (高密度電源コネクタ)
- 1 x SLI/XFire 電源コネクタ
- 1 x 前面パネルオーディオコネクタ
- 1 x SPDIF Out コネクタ
- 2 x USB 2.0 ヘッダー (4 つの USB 2.0 ポートをサポート)
- 1 x 縦型 A USB 3.0
- 1 x Etron EJ188 USB 3.0 ヘッダー (2 つの USB 3.0 ポートをサポート)

## BIOS 機能

- 32Mb AMI UEFI Legal BIOS、GUI 対応
- プラグ&プレイをサポート
- ACPI 1.1 準拠のウェイクアップイベント
- jumperfree モードサポート
- SMBIOS 2.3.1 をサポート
- CPU、DRAM、NB、HT、CPU VDDA、PCIE VDDA、CPU NB 複数電圧設定

## サポート CD

- ドライバー、ユーティリティー、アンチウイルスソフトウェア(トリアル版)、Google Chrome ブラウザー、Start8 (30 日トリアル版)、XSplit、Killer Network Manager

## ハードウェア アモニ ター

- CPU/ シャーシ温度センサー
- CPU/ シャーシ / 電源ファンタコメーター
- CPU/ シャーシ静音ファン (CPU 温度によるシャーシファン速度の自動調整可能)
- CPU/ シャーシファンマルチ速度制御
- 電圧監視: +12V、+5V、+3.3V、CPU Vcore

## OS

- Microsoft® Windows® 10 64 ビット / 8.1 32 ビット / 8.1 64 ビット / 8 32 ビット / 8 64 ビット / 7 32 ビット / 7 64 ビット

## 認証

- FCC、CE、WHQL
- ErP/EuP Ready (ErP/EuP ready 電源が必要です)

\*商品詳細については、当社ウェブサイトをご覧ください。<http://www.asrock.com>



BIOS 設定の調整、アンタイドオーバークロックテクノロジーの適用、サードパーティのオーバークロックツールの使用などを含む、オーバークロックには、一定のリスクを伴いますのでご注意ください。オーバークロックするとシステムが不安定になったり、システムのコンポーネントやデバイスが破損することがあります。ご自分の責任で行ってください。弊社では、オーバークロックによる破損の責任は負いかねますのでご了承ください。



1. 2450/2100MHz メモリ速度がサポートされているかどうかは、採用している AM3/AM3+ CPU によって異なります。このマザーボードに DDR3 2450/2100 メモリモジュールを採用する場合、WEB サイトのメモリサポートリストを参照して互換可能なメモリモジュールを見つけてください。  
ASRock Web サイト <http://www.asrock.com>
2. オペレーティングシステム制限のため、Windows® 8 / 7 使用下において、システム使用のリザーブに対する実際の記憶容量は 4GB 未満である可能性があります。64 ビット CPU の Windows® OS に対しては、そのような制限はありません。Windows® では使えないメモリを使用するために、アスロック XFast RAM を使用することができます。

### 1.3 ジャンパー設定

このイラストは、ジャンパーの設定方法を示しています。ジャンパーキャップがピンに被さっていると、ジャンパーは「ショート」です。ジャンパーキャップがピンに被さっていない場合には、ジャンパーは「オープン」です。この図は 3 ピンのジャンパーを表し、ジャンパーキャップがピン 1 とピン 2 に被さっているとき、これらのピンは「ショート」です。

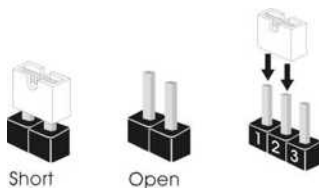

CMOS クリアジャンパー  
(CLRCMOS1)  
(p.1、No. 21 参照)



CLRCMOS1 は、CMOS のデータをクリアすることができます。クリアして、デフォルト設定にシステムパラメーターをリセットするには、コンピューターの電源を切り、電源から電源コードを抜いてください。15 秒待ってから、CLRCMOS1 のピン 2 とピン 3 をジャンパーキャップを使って 5 秒間ショートします。ただし、BIOS をアップデートした直後に、CMOS をクリアしないでください。BIOS をアップデート後、CMOS をクリアする必要がある場合は、最初にシステムを起動し、それから CMOS クリアアクションを行う前にシャットダウンしてください。パスワード、日付、時間、ユーザーのデフォルトプロファイルは、CMOS の電池を取り外した場合にのみ、消去されることにご注意ください。

## 1.4 オンボードのヘッダーとコネクタ



オンボードヘッダーとコネクタはジャンパーではありません。これらヘッダーとコネクタにはジャンパーキャップを被せないでください。ヘッダーおよびコネクタにジャンパーキャップを被せると、マザーボードに永久損傷が起こることがあります。

システムパネルヘッダー  
(9ピンパネル1)  
(p.1、No. 20 参照)

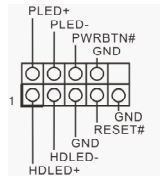

電源スイッチを接続し、スイッチをリセットし、下記のピン割り当てに従って、シャーシのシステムステータス表示ランプをこのヘッダーにセットします。ケーブルを接続するときには、ピンの+と-に気をつけてください。



**PWRBTN (電源スイッチ) :**

シャーシ前面パネルの電源スイッチに接続してください。電源スイッチを使用して、システムをオフにする方法を設定できます。

**RESET (リセットスイッチ) :**

シャーシ前面パネルのリセットスイッチに接続してください。コンピューターがフリーズしたり、通常の再起動を実行できない場合には、リセットスイッチを押して、コンピューターを再起動します。

**PLED (システム電源 LED) :**

シャーシ前面パネルの電源ステータス表示ランプに接続してください。システム稼働中は、LED が点灯します。システムが S1/S3 スリープ状態の場合には、LED は点滅を続けます。システムが S4 スリープ状態または電源オフ (S5) のときには、LED はオフです。

**HDLED (ハードドライブアクティビティ LED) :**

シャーシ前面パネルのハードドライブアクティビティ LED に接続してください。ハードドライブのデータを読み取りまたは書き込み中に、LED はオンになります。

前面パネルデザインは、シャーシによって異なることがあります。前面パネルモジュールは、主に電源スイッチ、リセットスイッチ、電源 LED、ハードドライブアクティビティ LED、スピーカーなどから構成されます。シャーシの前面パネルモジュールとこのヘッダーを接続する場合には、配線の割り当てと、ピンの割り当てが正しく合致していることを確かめてください。

電源 LED ヘッダー  
(3 ピン PLED1)  
(p.1、No. 18 参照)



システムの電源ステータスを表示するために、シャシー電源 LED をこのヘッダーに接続してください。

シリアル ATA3 コネクタ  
—

(SATA3\_1:  
p.1、No. 17 参照)  
(SATA3\_2:  
p.1、No. 16 参照)  
(SATA3\_3:  
p.1、No. 14 参照)  
(SATA3\_4:  
p.1、No. 15 参照)  
(SATA3\_5:  
p.1、No. 12 参照)

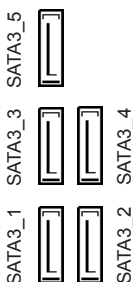

これら 5 つの SATA3 コネクタは、最高 6.0 Gb/秒のデータ転送速度で内部ストレージデバイス用の SATA データケーブルをサポートします。

USB 2.0 ヘッダー  
(9 ピン USB6\_7)  
(p.1、No. 9 参照)  
(9 ピン USB8\_9)  
(p.1、No. 8 参照)

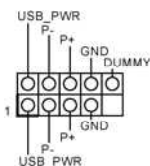

I/O パネルの 6 つの USB 2.0 ポートに加えて、このマザーボードには 2 つのヘッダーがあります。各 USB 2.0 ヘッダーは、2 つのポートをサポートできます。

USB 3.0 ヘッダー  
(19 ピン USB3\_5\_6)  
(p.1、No. 10 参照)

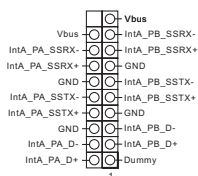

(USB3\_7)  
(p.1、No. 11 参照)



I/O パネルの 4 つの USB 3.0 ポートに加えて、このマザーボードには 1 つのヘッダーと 1 つのポートが装備されています。各 USB 3.0 ヘッダーは、2 つのポートをサポートできます。

### フロントパネルオーディオヘッダー

(9ピン HD\_AUDIO1)  
(p.1, No. 27 参照)

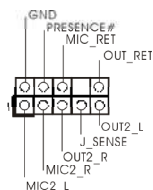

このヘッダーは、フロントオーディオパネルにオーディオデバイスを接続するためのものです。



- ハイディフィニションオーディオはジャックセンシングをサポートしていますが、正しく機能するためには、シャーシのパネルワイヤーが HDA をサポートしている必要があります。お使いのシステムを取り付けるには、当社のマニュアルおよびシャーシのマニュアルの指示に従ってください。
- AC' 97 オーディオパネルを使用する場合には、次のステップで、前面パネルオーディオヘッダーに取り付けてください。
  - Mic\_IN (MIC) を MIC2\_L に接続。
  - Audio\_R (RIN) を OUT2\_R に、Audio\_L (LIN) を OUT2\_L に接続。
  - アース (GND) をアース (GND) に接続。
  - MIC\_RET と OUT\_RET は、HD オーディオパネル専用です。AC' 97 オーディオパネルではこれらを接続する必要はありません。
  - フロントマイクを有効にするには、Realtek コントロールパネルの「FrontMic」タブで、「録音音量」を調整してください。

### シャーシスピーカーヘッダー

(4ピン SPEAKER1)  
(p.1, No. 19 参照)



シャーシスピーカーはこのヘッダーに接続してください。

### シャーシと電源ファンコネクタ

(4ピン CHA\_FAN1)  
(p.1, No. 29 参照)

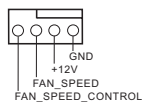

ファンケーブルはファンコネクタに接続し、黒線とアースピンを合わせてください。

(3ピン CHA\_FAN2)  
(p.1, No. 1 参照)

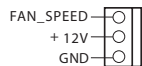

(3ピン CHA\_FAN3)  
(p.1, No. 22 参照)



(3ピン PWR\_FAN1)  
(p.1, No. 28 参照)



CPU ファンコネクター  
(4ピン CPU\_FAN1)  
(p.1、No. 3 参照)

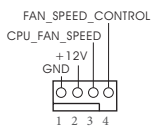

(3ピン CPU\_FAN2)  
(p.1、No. 4 参照)

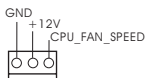

このマザーボードは4ピンCPUファン(静音ファン)コネクターを提供します。3ピンのCPUファンを接続する場合には、ピン1-3に接続してください。

ATX 電源コネクター  
(24ピン ATXPWR1)  
(p.1、No. 7 参照)

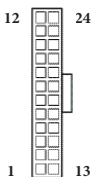

このマザーボードは24ピンATX電源コネクターを提供します。20ピンのATX電源を使用するには、ピン1と13番に合わせて接続してください。

ATX12V 電源コネクター  
(8ピン ATX12V1)  
(p.1、No. 2 参照)

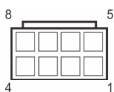

このマザーボードは8ピンATX12V電源コネクターを提供します。4ピンのATX電源を使用するには、ピン1と5番に合わせて接続してください。

SLI/XFIRE 電源コネクタ  
(4ピン SLI/XFIRE\_ PWR1)  
(p.1、No. 23 参照)



このマザーボードに3枚のグラフィックスカードを取り付ける場合は、このコネクタをハードディスク電源コネクタと接続してください。

赤外モジュールヘッダー  
(5ピン IR1)  
(p.1、No. 24 参照)

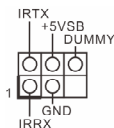

このヘッダーはオプションのワイヤレス送受信赤外モジュールをサポートしています。

## シリアルポートヘッダー

(9ピン COM1)

(p.1, No. 25 参照)

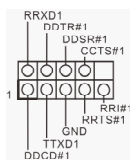

この COM1 ヘッダーはシリアルポートモジュールをサポートします。

## SPDIF Out コネクタ

(2ピン SPDIF\_OUT1)

(p.1, No. 26 参照)



ケーブルを使用して、HDMI VGA カードの SPDIF\_OUT コネクタをこのヘッダーに接続してください。

## TPM ヘッダー

(17ピン TPMS1)

(p.1, No. 13 参照)

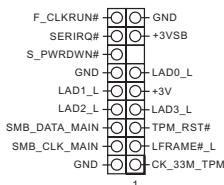

このコネクタはトラステッドプラットフォームモジュール (TPM) システムをサポートし、鍵、デジタル証明書、パスワード、データを安全に保管することができます。TPM システムはまた、ネットワークセキュリティを高め、デジタル証明書を保護し、プラットフォームの完全性を保証します。

# 1 简介

感谢您购买 ASRock FatalIty 990FX Killer 系列主板，这是按照 ASRock 一贯严格质量控制标准生产的性能可靠的主板。它提供符合 ASRock 质量和耐久性承诺的精良设计和卓越性能。



由于主板规格和 BIOS 软件可能已更新，因此，本手册的内容可能会随时更改，恕不另行通知。如果本手册有任何修改，则更新的版本将发布在 ASRock 网站上，我们不会另外进行通知。如果您需要与此主板相关的技术支持，请访问我们的网站以具体了解所用型号的信息。您也可以在 ASRock 网站上找到最新 VGA 卡和 CPU 支持列表。ASRock 网站 <http://www.asrock.com>。

## 1.1 包装清单

- ASRock FatalIty 990FX Killer 系列主板 (ATX 规格尺寸)
- ASRock FatalIty 990FX Killer 系列主板快速安装指南
- ASRock FatalIty 990FX Killer 系列主板支持光盘
- 4 x 串行 ATA (SATA) 数据线 (选购)
- 1 x I/O 面板
- 1 x ASRock SLL\_Bridge\_2S 卡
- 1 x M.2\_SSD (NGFF) Socket 3 螺丝

## 1.2 规格

### 平台

- ATX 规格尺寸
- 优质亮金电容器设计 (100% 日本造高品质导电性高分子电容器)

### A-Style

- 115dB 超高保真音效

### 游戏装备

#### CPU 电源

- 高密度电源接口

#### VGA 卡

- VGA PCIe 槽 (PCIe2/PCIe3) 中 15 $\mu$  Gold Finger (金手指)
- SLI/XFire 电源接口

#### Internet

- Qualcomm® Atheros® Killer™ LAN

#### 音频

- 115dB 超高保真音效

### CPU

- 支持 Socket AM3+ 处理器
- 支持 Socket AM3 处理器 : AMD Phenom™ II X6 / X4 / X3 / X2(920/940 除外) / Athlon II X4 / X3 / X2 / Sempron 处理器
- 八核心 CPU 就绪
- 支持 UCC (Unlock CPU Core)
- Digi Power 设计
- 高级 8 + 2 电源相位设计
- 支持高达 140W 的 CPU
- 支持 AMD Cool 'n' Quiet™ 冷静技术
- 支持 FSB 2600 MHz (5.2 GT/s)
- 支持异步超频技术
- 支持 Hyper-Transport 3.0 (HT 3.0) 技术

### 芯片集

- 北桥 : AMD 990FX
- 南桥 : AMD SB950

### 内存

- 双通道 DDR3 内存技术
- 4 x DDR3 DIMM 槽
- 支持 DDR3 2450(超频)/2100(超频)/1600/1333/1066 非 ECC, 非缓冲内存 (见“注意 1”)
- 支持系统内存容量 : 64GB (见“注意 2”)

- 支持 Intel® Extreme Memory Profile (XMP)1.3/1.2
- 支持 AMD Memory Profile (AMP) 技术

## 扩充槽

- 3 x PCI Express 2.0 x16 槽 (PCIe2/PCIe3: x16 模式、PCIe5: x4 模式)
- 2 x PCI Express 2.0 x1 槽
- 支持 AMD Quad CrossFireX™、3 向 CrossFireX™ 和 CrossFireX™
- 支持 NVIDIA® Quad SLI™ 和 SLI™

## 音频

- 具有内容保护功能的 7.1 CH 高清音频 (Realtek ALC1150 音频编解码器)
- 优质 Blu-ray 音频支持
- 支持 115dB 超高保真音效
  - 115dB SNR DAC, 带微分放大器
  - TI® NE5532 优质耳放 (最高 600 Ohms 高品质耳机放大器)
  - Direct Drive (直接驱动) 技术
  - EMI 屏蔽罩
  - PCB 隔离罩
- 支持 DTS 连接

## LAN

- PCI-E x1 Gigabit LAN 10/100/1000 Mb/s
- Qualcomm® Atheros® Killer™ E2200 系列
- 支持 Wake-On-LAN (网上唤醒)
- 支持高能效以太网 802.3az
- 支持 PXE

## 后面板 I/O

- 1 x PS/2 鼠标端口
- 1 x PS/2 键盘端口
- 1 x 光学 SPDIF 输出端口
- 5 x USB 2.0 端口
- 1 x Fatal1ty 鼠标端口 (USB 2.0)
- 4 x USB 3.0 端口 (ASMedia Hub)
- 1 x eSATA3 接口
- 1 x RJ-45 LAN 端口, 带 LED (ACT/LINK LED 和 SPEED LED)

- 高清音频插孔：后扬声器 / 中央 / 低音 / 线路输入 / 前扬声器 / 麦克风

### 存储

- 5 x SATA3 6.0 Gb/s 接口，支持 RAID (RAID 0、RAID 1、RAID 0+1、JBOD 和 RAID 5)、NCQ、AHCI 和“热插拔”
- 1 x M.2\_SSD (NGFF) Socket 3，支持 M.2 SATA3 6.0 Gb/s 模块和 M.2 PCI Express 模块，最高 Gen2 x2 (10 Gb/s) (M.2\_SSD (NGFF) Socket 3 与 eSATA3 接口共享)

### 接口

- 1 x IR 接脚
- 1 x COM 端口接脚
- 1 x TPM 接脚
- 1 x 电源 LED 接脚
- 2 x CPU 风扇接口 (1 x 4 针, 1 x 3 针)
- 3 x 机箱风扇接口 (1 x 4 针, 2 x 3 针)
- 1 x 电源风扇接口 (3 针)
- 1 x 24 针 ATX 电源接口
- 1 x 8 针 12V 电源接口 (高密度电源接口)
- 1 x SLI/XFire 电源接口
- 1 x 前面板音频接口
- 1 x SPDIF 输出接口
- 2 x USB 2.0 接脚 (支持 4 个 USB 2.0 端口)
- 1 x 垂直 A 类型 USB 3.0
- 1 x Etron EJ188 USB 3.0 接脚 (支持 2 个 USB 3.0 端口)

### BIOS 功能特点

- 32Mb AMI UEFI Legal BIOS，具有 GUI 支持
- 支持即插即用 (Plug and Play, PnP)
- ACPI 1.1 兼容唤醒事件
- 支持 jumperfree 免跳线模式
- SMBIOS 2.3.1 支持
- CPU、DRAM、NB、HT、CPU VDDA、PCIE VDDA、CPU NB 电压多次调整 (Voltage Multi-adjustment)

### 支持光盘

- 驱动程序、实用程序、防病毒软件 (试用版)、Google Chrome 浏览器和工具栏、Start8(30 天试用版)、XSplit、Killer Network Manager

## 硬件监控

- CPU/ 机箱温度感测
- CPU/ 机箱 / 电源风扇转速计
- CPU/ 机箱静音风扇 (可以按照 CPU 温度自动调整机箱风扇速度)
- CPU/ 机箱风扇多种速度控制
- 电压监控 : +12V、+5V、+3.3V、CPU Vcore

## 操作系统

- Microsoft® Windows® 10 64-bit / 8.1 32-bit / 8.1 64-bit / 8 32-bit / 8 64-bit / 7 32-bit / 7 64-bit

## 认证

- FCC、CE、WHQL
- ErP/EuP 支持 (需要支持 ErP/EuP 的电源)

\* 有关详细产品信息, 请访问我们的网站: <http://www.asrock.com>



须认识到超频会有一定风险，包括调整 BIOS 设置，应用“自由超频技术”，或使用第三方超频工具。超频可能会影响到系统的稳定性，甚至对系统的组件和设备造成损坏。执行这项工作您应自担风险和自己承担费用。我们对由于超频而造成的损坏概不负责。



1. 2450/2100MHz 内存频率是否支持在于您使用的 AM3 CPU。如果您想在这款主板上使用 DDR3 2450/2100 内存条，请查阅我们网站的内存支持列表了解兼容的内存。  
華擎網站：<http://www.asrock.com>
2. 由于操作系统的限制，在 Windows® 8 / 7 下，供系统使用的实际内存容量可能小于 4GB。对于 Windows® 操作系统搭配 64 位元 CPU 来说，不会存在这样的限制。您可以使用 ASRock XFast RAM 来利用 Windows® 不能使用的内存。

## 1.3 跳线设置

此图显示如何设置跳线。将跳线帽装到这些针脚上时，跳线“短接”。如果这些针脚上没有装跳线帽，跳线“开路”。此图显示 3 针跳线，当跳线帽装在针脚 1 和针脚 2 上，它们“短接”。

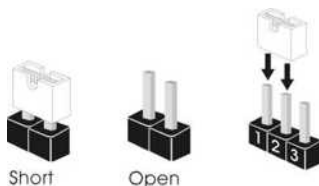

清除 CMOS 跳线

(CLRCMOS1)

(见第 1 页, 第 21 个)



默认



清除 CMOS

CLRCMOS1 允许您清除 CMOS 中的数据。要清除和重置系统参数到默认设置，请关闭计算机，从电源上拔下电源线插头。等候 15 秒后，使用跳线帽将 CLRCMOS1 上的针脚 2 和针脚 3 短接 5 秒。但是，请勿在更新 BIOS 后立即清除 CMOS。如果您需要在刚完成 BIOS 更新后清除 CMOS，则必须先启动系统，并在关闭后再执行清除 CMOS 操作。请注意，密码、日期、时间和用户默认配置文件只在卸下 CMOS 电池后才会被清除。

## 1.4 板载接脚和接口



板载接脚和接口不是跳线。不要将跳线帽装到这些接脚和接口上。将跳线帽装到这些接脚和接口上将会对主板造成永久性损坏。

### 系统面板接脚

(9 针 PANEL1)

(见第 1 页, 第 20 个)

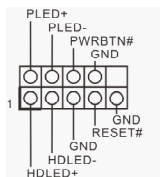

按照下面的针脚分配, 将机箱上的电源开关、重置开关和系统状态指示灯连接到此接脚。在连接线缆前请记下正负针脚。



**PWRBTN** (电源开关):

连接到机箱前面板上的电源开关。您可以配置使用电源开关关闭系统的方式。

**RESET** (重置开关):

连接到机箱前面板上的重置开关。如果计算机死机, 无法执行正常重新启动, 按重置开关重新启动计算机。

**PLED** (系统电源 LED):

连接到机箱前面板上的状态指示灯。系统操作操作时, 此 LED 亮起。系统处在 S1/S3 睡眠状态时, 此 LED 闪烁。系统处在 S4 睡眠状态或关机 (S5) 时, 此 LED 熄灭。

**HDLED** (硬盘活动指示灯):

连接到机箱前面板上的硬盘活动 LED 指示灯。硬盘正在读取或写入数据时, 此 LED 亮起。

前面板设计根据机箱不同而有所差异。前面板模块主要包括电源开关、重置开关、电源 LED、硬盘活动 LED 指示灯、扬声器等。将机箱前面板模块连接到此接脚时, 确保连线分配和针脚分配正确匹配。

### 电源 LED 接口

(3 针 PLED1)

(见第 1 页, 第 18 个)



请将机箱电源 LED 连接到此接口以指示系统电源状态。

### 串行 ATA3 接口

(SATA3\_1:

见第 1 页, 第 17 个)

(SATA3\_2:

见第 1 页, 第 16 个)

(SATA3\_3:

见第 1 页, 第 14 个)

(SATA3\_4:

见第 1 页, 第 15 个)

(SATA3\_5:

见第 1 页, 第 12 个)

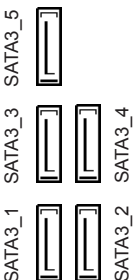

这五个 SATA3 接口支持最高 6.0 Gb/s 数据传输速率的内部存储设备的 SATA 数据线。

### USB 2.0 接口

(5 针 USB6\_7)

(见第 1 页, 第 9 个)

(9 针 USB8\_9)

(见第 1 页, 第 8 个)

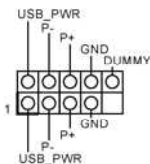

除 I/O 面板上的六个 USB 2.0 端口外, 此主板上还有两个接口。每个 USB 2.0 接口可以支持两个端口。

### USB 3.0 接口

(19 针 USB3\_5\_6)

(见第 1 页, 第 10 个)

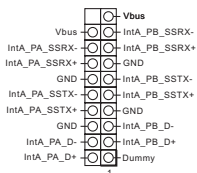

除 I/O 面板上的四个 USB 3.0 端口外, 此主板上还有 1 个接口和一个端口。每个 USB 3.0 接口可以支持两个端口。

(USB3\_7)

(见第 1 页, 第 11 个)



## 前面板音频接口

(9 针 HD\_AUDIO1)  
(见第 1 页, 第 27 个)

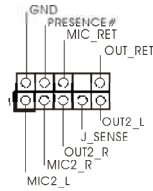

此接口用于将音频设备连接到前音频面板。



1. 高清音频支持插孔感测, 但机箱上的面板连线必须支持 HDA 才能正常工作。请按照我们的手册和机箱手册的说明安装系统。
2. 如果您使用 AC' 97 音频面板, 请按照以下步骤安装到前面板音频接口:
  - A. 将 Mic\_IN (MIC) 连接到 MIC2\_L。
  - B. 将 Audio\_R (RIN) 连接到 OUT2\_R, 将 Audio\_L (LIN) 连接到 OUT2\_L。
  - C. 将接地端 (GND) 连接到接地端 (GND)。
  - D. MIC\_RET 和 OUT\_RET 只用于高清音频面板。您不需要针对 AC' 97 音频面板连接它们。
  - E. 要启用前麦克风, 请转到 Realtek 控制面板上的“FrontMic” (前麦克风) 选项卡, 调整“Recording Volume” (录音音量)。

## 机箱扬声器接口

(4 针 SPEAKER1)  
(见第 1 页, 第 19 个)

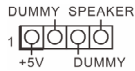

请将机箱扬声器连接到此接口。

## 机箱和电源风扇接口

(4 针 CHA\_FAN1)  
(见第 1 页, 第 29 个)

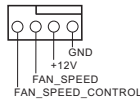

请将风扇线连接到风扇接口并使黑线匹配接地针脚。

(3 针 CHA\_FAN2)  
(见第 1 页, 第 1 个)

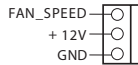

(3 针 CHA\_FAN3)  
(见第 1 页, 第 22 个)



(3 针 PWR\_FAN1)  
(见第 1 页, 第 28 个)



CPU 风扇接口  
 (4 针 CPU\_FAN1)  
 (见第 1 页, 第 3 个)

(3 针 CPU\_FAN2)  
 (见第 1 页, 第 4 个)

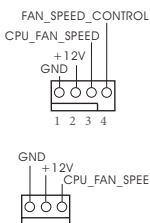

此主板提供 4 针 CPU 风扇 (静音风扇) 接口。如果您打算连接 3 针 CPU 风扇, 请将它连接到针脚 1-3。

ATX 电源接口  
 (24 针 ATXPWR1)  
 (见第 1 页, 第 7 个)

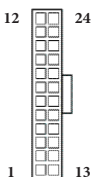

此主板提供 24 针 ATX 电源接口。要使用 20 针 ATX 电源, 请沿针脚 1 和针脚 13 插接它。

ATX 12V 电源接口  
 (8 针 ATX12V1)  
 (见第 1 页, 第 2 个)

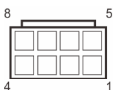

此主板提供 8 针 ATX 12V 电源接口。要使用 4 针 ATX 电源, 请沿针脚 1 和针脚 5 插接它。

SLI/XFIRE 电源接口  
 (4 针 SLI/XFIRE\_PWR1)  
 (见第 1 页, 第 23 个)



当此主板上安装有三个图形卡时, 请通过硬盘电源接口连接此接口。

红外线模块接脚  
 (5 针 IR1)  
 (见第 1 页, 第 24 个)

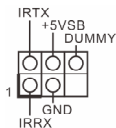

此接脚支持选购的无线发射和接收红外线模块。

串行端口接脚  
 (9 针 COM1)  
 (见第 1 页, 第 25 个)

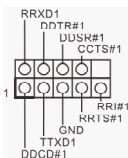

此 COM1 接脚支持串行端口模块。

SPDIF 输出接口  
(2 针 SPDIF\_OUT1)  
(见第 1 页, 第 26 个)



请使用线缆将 HDMI  
VGA 卡的 SPDIF\_OUT  
接口连接到此接口。

TPM 接脚  
(17 针 TPM1)  
(见第 1 页, 第 13 个)

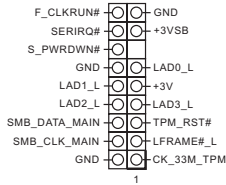

此接口支持 Trusted  
Platform Module (信任平  
台模块, TPM) 系统, 可  
以安全地存储密钥、数字  
证书、密码和数据。TPM  
系统也可以帮助增强网络  
安全, 保护数字身份和确  
保平台完整性。

## 電子信息產品污染控制標示

依据中国发布的「电子信息产品污染控制管理办法」及 SJ/T 11364-2006「电子信息产品污染控制标示要求」，电子信息产品应进行标示，藉以向消费者揭露产品中含有的有毒有害物质或元素不致发生外泄或突变从而对环境造成污染或对人身、财产造成严重损害的期限。依上述规定，您可于本产品之印刷电路板上看见图一之标示。图一中之数字为产品之环保使用期限。由此可知此主板之环保使用期限为 10 年。



图一

## 有毒有害物質或元素的名稱及含量說明

若您欲了解此产品的有毒有害物质或元素的名称及含量说明，请参照以下表格及说明。

部件名称	有害物质或元素					
	铅 (Pb)	镉 (Cd)	汞 (Hg)	六价铬 (Cr (VI))	多溴联苯 (PBB)	多溴二苯醚 (PBDE)
印刷电路板及电子组件	X	O	O	O	O	O
外部信号连接器及线材	X	O	O	O	O	O

O: 表示该有毒有害物质在该部件所有均质材料中的含量均在 SJ/T 11363-2006 标准规定的限量要求以下。

X: 表示该有毒有害物质至少在该部件的某一均质材料中的含量超出 SJ/T 11363-2006 标准规定的限量要求，然该部件仍符合欧盟指令 2002/95/EC 的规范。

备注：此产品所标示之环保使用年限，系指在一般正常使用状况下。

# 1 簡介

感謝您購買 Fatal1ty 990FX Killer 系列主機板，本主機板經 ASRock 嚴格品質製作，是一套讓人信賴的可靠產品。本產品採耐用設計所展現的優異效能，完全符合 ASRock 對品質及耐用度的承諾。



由於主機板規格及 BIOS 軟體可能會更新，所以本手冊內容如有變更恕不另行通知。如本手冊有任何修改，可至 ASRock 網站逕行取得更新版本，不另外通知。若您需要與本主機板相關的技術支援，請上我們的網站瞭解有關您使用機型的特定資訊。您也可以到 ASRock 網站找到最新的 VGA 卡及 CPU 支援清單。ASRock 網站 <http://www.asrock.com>。

## 1.1 包裝內容

- ASRock Fatal1ty 990FX Killer 系列主機板 (ATX 尺寸)
- ASRock Fatal1ty 990FX Killer 系列快速安裝指南
- ASRock Fatal1ty 990FX Killer 系列支援光碟
- 4 x Serial ATA (SATA) 資料纜線 (選用)
- 1 x I/O 面板外罩
- 1 x ASRock SLI\_Bridge\_2S 卡
- 1 x M.2\_SSD (NGFF) Socket 3 插槽螺絲

## 1.2 規格

### 平台

- ATX 尺寸
- 黃金級電容設計 (100% 日本製高品質固態高分子電容)

### A-Style

- Purity Sound™ 115dB 天籟美聲

### 頂級遊戲配備

#### CPU 電源

- 高密度電源接頭

#### VGA 卡

- 15 $\mu$ Gold Finger 於 VGA PCIe 插槽 (PCIe2/PCIe3)
- SLI/XFire 電源接頭

#### 網際網路

- Qualcomm® Atheros® Killer™ LAN

#### 音訊

- Purity Sound™ 115dB 天籟美聲

### CPU

- 支援 Socket AM3+ 處理器
- 支援 Socket AM3 處理器 : AMD Phenom™ II X6 / X4 / X3 / X2(920 / 940 除外) / Athlon II X4 / X3 / X2 / Sempron 處理器
- 八核心 CPU 就緒
- 支援 UCC (Unlock CPU Core)
- 數位電源設計
- 高級 8 + 2 電源相位設計
- 支援高達 140W 的 CPU
- 支援 AMD Cool 'n' Quiet 冷靜技術
- 支援 FSB 2600 MHz (5.2 GT/s)
- 支援非同步超頻技術
- 支援 Hyper-Transport 3.0 (HT 3.0) 技術

### 晶片組

- 北橋 : AMD 990FX
- 南橋 : AMD SB950

### 記憶體

- 雙通道 DDR3 記憶體技術
- 4 x DDR3 DIMM 插槽
- 支援 DDR3 2450(超頻)/2100(超頻)/1600/1333/1066 非 ECC、無緩衝記憶體 (請參閱「注意 1」)
- 最大系統記憶體容量 : 64GB (請參閱「注意 2」)
- 支援 Intel® Extreme Memory Profile (XMP)1.3/1.2

- 支援 AMD Memory Profile (AMP) 記憶體模組技術

### 擴充插槽

- 3 x PCI Express 2.0 x16 插槽 (PCIe2/PCIe3 : x16 模式、PCIe5 : x4 模式)
- 2 x PCI Express 2.0 x1 插槽
- 支援 AMD Quad CrossFireX™、3-Way CrossFireX™ 及 CrossFireX™
- 支援 NVIDIA® Quad SLI™ 及 SLI™

### 音訊

- 7.1 CH HD 音訊含內容保護 (Realtek ALC1150 音訊轉碼器) 功能
- 高階藍光音訊支援
- 支援 Purity Sound™ 115dB 天籟美聲
  - 115dB SNR DAC 及差動放大器
  - TI\* NE5532 (支援最高 600 Ohms 的 Premium Headset Amplifier)
  - 直驅技術
  - EMI 遮蔽蓋
  - PCB 隔離遮蔽
- 支援 DTS Connect

### LAN

- PCIe x1 Gigabit LAN 10/100/1000 Mb/s
- Qualcomm® Atheros® Killer™ E2200 系列
- 支援網路喚醒
- 支援 Energy Efficient Ethernet 802.3az
- 支援 PXE

### 後面板 I/O

- 1 x PS/2 滑鼠連接埠
- 1 x PS/2 鍵盤連接埠
- 1 x 光纖 SPDIF 輸出連接埠
- 5 x USB 2.0 連接埠
- 1 x Fatal1ty 滑鼠連接埠 (USB 2.0)
- 4 x USB 3.0 連接埠 (ASMedia 集線器)
- 1 x eSATA3 接頭
- 1 x RJ-45 LAN 連接埠, 含 LED (ACT/LINK LED 及 SPEED LED)
- HD 音訊插孔: 後置喇叭 / 中置 / 低音 / 線路輸入 / 前置喇叭 / 麥克風

## 儲存裝置

- 5 x SATA3 6.0 Gb/s 接頭支援 RAID (RAID 0、RAID 1、RAID 0+1、JBOD 及 RAID 5)、NCQ、AHCI 及「熱插拔」
- 1 x M.2\_SSD (NGFF) Socket 3 插槽，支援 M.2 SATA3 6.0 Gb/s 模組及 M.2 PCI Express 模組，最高可達 Gen2 x2 (10 Gb/s) (M.2\_SSD (NGFF) Socket 3 插槽與 eSATA3 接頭共用)

## 接頭

- 1 x IR 排針
- 1 x COM 連接埠排針
- 1 x TPM 標頭
- 1 x 電源 LED 排針
- 2 x CPU 風扇接頭 (1 x 4-pin、1 x 3-pin)
- 3 x 機殼風扇接頭 (1 x 4-pin、2 x 3-pin)
- 1 x 電源風扇接頭 (3-pin)
- 1 x 24 pin ATX 電源接頭
- 1 x 8 pin 12V 電源接頭 (高密度電源接頭)
- 1 x SLI/XFire 電源接頭
- 1 x 前面板音訊接頭
- 1 x SPDIF 輸出接頭
- 2 x USB 2.0 排針 (支援 4 USB 2.0 連接埠)
- 1 x 直式 A USB 3.0
- 1 x Etron EJ188 USB 3.0 排針 (支援 2 USB 3.0 連接埠)

## BIOS 功能

- 32Mb AMI UEFI Legal BIOS，具備 GUI 支援
- 支援即插即用 (Plug and Play, PnP)
- ACPI 1.1 符合喚醒自動開機
- 支援 jumperfree 免跳線模式
- 支援 SMBIOS 2.3.1
- CPU、DRAM、NB、HT、CPU VDDA、PCIE VDDA、CPU NB 電壓多重調整

## 支援 CD

- 驅動程式、公用程式、防毒軟體 (試用版)、Google Chrome 瀏覽器及工具列、Start8 (30 天試用)、XSplit、Killer Network Manager

**硬體監視器**

- CPU / 機殼溫度感應
- CPU / 機殼 / 電源風扇轉速計
- CPU / 機殼靜音風扇 (允許按照 CPU 溫度自動調整機殼風扇速度)
- CPU / 機殼風扇多重速度控制
- 電壓監控: +12V、+5V、+3.3V、CPU Vcore

**作業系統**

- Microsoft® Windows® 10 64 位元 / 8.1 32 位元 / 8.1 64 位元 / 8 32 位元 / 8 64 位元 / 7 32 位元 / 7 64 位元

**認證**

- FCC、CE、WHQL
- ErP/EuP Ready (需具備 ErP/EuP ready 電源供應器)

\* 如需產品詳細資訊，請造訪我們的網站：<http://www.asrock.com>



請務必理解，超頻可能產生某種程度的風險，其中包括調整 BIOS 中的設定、採用自由超頻技術或使用協力廠商的超頻工具。超頻可能會影響您系統的穩定性，或者甚至會對您系統的元件及裝置造成傷害。您應自行負擔超頻風險及成本。我們對於因超頻所造成的可能損害概不負責。



1. 2450/2100MHz 記憶體頻率是否支援在於您使用的 AM3/AM3+ CPU。如果您想在這款主板上使用 DDR3 2450/2100 記憶體，請查閱我們網站的記憶體支援列表了解相容的記憶體。  
華擎網站：<http://www.asrock.com>
2. 由於作業系統的限制，在 Windows® 8 / 7 下，供系統使用的實際記憶體容量可能小於 4GB。對於 Windows® 作業系統搭配 64 位元 CPU 來說，不會存在這樣的限制。您可使用 ASRock XFast RAM 運用 Windows® 無法使用的記憶體。

### 1.3 跳線設定

圖例顯示設定跳線的方式。當跳線帽套在針腳上時，該跳線為「短路」。若沒有跳線帽套在針腳上，該跳線為「開啟」。圖例顯示當 3-pin 跳線的跳線帽套在 pin1 及 pin2 時，這兩個針腳皆為「短路」。

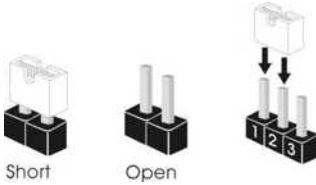

清除 CMOS 跳線  
(CLRCMOS1)  
(請參閱第 1 頁，編號 21)



您可利用 CLRCMOS1 清除 CMOS 中的資料。若要清除及重設系統參數為預設設定，請先關閉電腦電源，再拔下電源供應器的電源線。在等待 15 秒後，請使用跳線帽讓 CLRCMOS1 上的 pin2 及 pin3 短路約 5 秒。不過，請不要在更新 BIOS 後立即清除 CMOS。若您需在更新 BIOS 後立即清除 CMOS，則必須先重新啟動系統，然後於進行清除 CMOS 動作前關機。請注意，只有在取出 CMOS 電池時才會清除密碼、日期、時間及使用者預設設定檔。

## 1.4 板載排針及接頭



板載排針及接頭都不是跳線。請勿將跳線帽套在這些排針及接頭上。將跳線帽套在排針及接頭上，將造成主機板永久性的受損。

系統面板排針  
(9-pin PANEL1)  
(請參閱第 1 頁，編號 20)

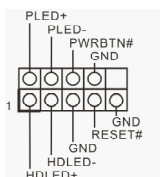

請依照以下的針腳排列將機殼上的電源開關、重設開關及系統狀態指示燈連接至此排針。在連接纜線之前請注意正負針腳。



**PWRBTN (電源開關) :**

連接至機殼前面板上的電源開關。您可設定使用電源開關關閉系統電源的方式。

**RESET (重設開關) :**

連接至機殼前面板上的重設開關。若電腦凍結且無法執行正常重新啟動，按下重設開關即可重新啟動電腦。

**PLED (系統電源 LED) :**

連接至機殼前面板上的電源狀態指示燈。系統正在運作時，此 LED 會亮起。系統進入 S1/S3 睡眠狀態時，LED 會持續閃爍。系統進入 S4 睡眠狀態或關機 (S5) 時，LED 會熄滅。

**HDLED (硬碟活動 LED) :**

連接至機殼前面板上的硬碟活動 LED。硬碟正在讀取或寫入資料時，LED 會亮起。

各機殼的前面板設計各有不同。前面板模組主要是由電源開關、重設開關、電源 LED、硬碟活動 LED、喇叭及其他裝置組成。將機殼前面板模組連接至此排針時，請確定佈線及針腳指派皆正確相符。

## 電源 LED 排針

(3-pin PLED1)

(請參閱第 1 頁, 編號 18)



請將機殼電源 LED 連接至此排針, 以指示系統的電源狀態。

## Serial ATA3 接頭

(SATA3\_1:

請參閱第 1 頁, 編號 17)

(SATA3\_2:

請參閱第 1 頁, 編號 16)

(SATA3\_3:

請參閱第 1 頁, 編號 14)

(SATA3\_4:

請參閱第 1 頁, 編號 15)

(SATA3\_5:

請參閱第 1 頁, 編號 12)

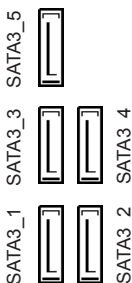

這五組 SATA3 接頭皆支援內部儲存裝置的 SATA 資料纜線, 最高可達 6.0 Gb/s 資料傳輸率。

## USB 2.0 排針

(9-pin USB6\_7)

(請參閱第 1 頁, 編號 9)

(9-pin USB8\_9)

(請參閱第 1 頁, 編號 8)

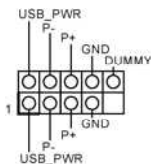

除了 I/O 面板上的六個 USB 2.0 連接埠外, 在本主機板上還有另外兩組排針。各 USB 2.0 排針皆可支援兩個連接埠。

## USB 3.0 排針

(19-pin USB3\_5\_6)

(請參閱第 1 頁, 編號 10)

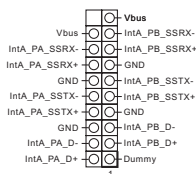

除了 I/O 面板上的四個 USB 3.0 連接埠外, 在本主機板上還有另外一組排針及一個連接埠。各 USB 3.0 排針皆可支援兩個連接埠。

(USB3\_7)

(請參閱第 1 頁, 編號 11)



## 前面板音訊排針

(9-pin HD\_AUDIO1)

(請參閱第 1 頁, 編號 27)

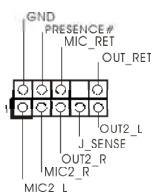

本排針適用於連接音訊裝置至前面板音訊。



1. 高解析度音訊支援智慧型音效介面偵測 (Jack Sensing), 但機殼上的面板線必須支援 HDA 才能正確運作。請依本手冊及機殼手冊說明安裝系統。
2. 若您使用 AC'97 音訊面板, 請按照以下步驟安裝至前面板音訊排針:
  - A. 將 Mic\_IN (MIC) 連接至 MIC2\_L。
  - B. 將 Audio\_R (RIN) 連接至 OUT2\_R 且將 Audio\_L (LIN) 連接至 OUT2\_L。
  - C. 將接地 (GND) 連接至接地 (GND)。
  - D. MIC\_RET 及 OUT\_RET 僅供 HD 音訊面板使用。您不需要在 AC'97 音訊面板上連接。
  - E. 若要啟動前側麥克風, 請前往 Realtek 控制面板中的「FrontMic」標籤調整「錄音音量」。

## 機殼喇叭排針

(4-pin SPEAKER1)

(請參閱第 1 頁, 編號 19)



請將機殼喇叭連接至此排針。

## 機殼及電源風扇接頭

(4-pin CHA\_FAN1)

(請參閱第 1 頁, 編號 29)

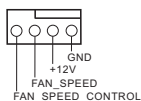

請將風扇纜線連接至風扇接頭, 並比對黑線及接地針腳。

(3-pin CHA\_FAN2)

(請參閱第 1 頁, 編號 1)

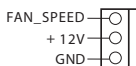

(3-pin CHA\_FAN3)

(請參閱第 1 頁, 編號 22)



(3-pin PWR\_FAN1)

(請參閱第 1 頁, 編號 28)



## CPU 風扇接頭

(4-pin CPU\_FAN1)

(請參閱第 1 頁, 編號 3)

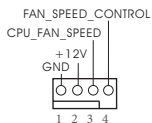

(3-pin CPU\_FAN2)

(請參閱第 1 頁, 編號 4)

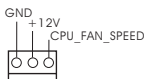

本主機板配備 4-Pin CPU 風扇 (靜音風扇) 接頭。若您計畫連接 3-Pin CPU 風扇, 請接至 Pin 1-3。

## ATX 電源接頭

(24-pin ATXPWR1)

(請參閱第 1 頁, 編號 7)

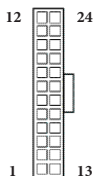

本主機板配備一組 24-pin ATX 電源接頭。若要使用 20-pin ATX 電源供應器, 請插入 Pin 1 及 Pin 13。

## ATX 12V 電源接頭

(8-pin ATX12V1)

(請參閱第 1 頁, 編號 2)

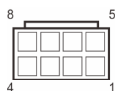

本主機板配備一組 8-pin ATX 12V 電源接頭。若要使用 4-pin ATX 電源供應器, 請插入 Pin 1 及 Pin 5。

## SLI/XFIRE 電源接頭

(4-pin SLI/XFIRE\_PWR1)

(請參閱第 1 頁, 編號 23)



在本主機板上安裝三張顯示卡時, 請將此接頭接至硬碟電源接頭。

## 紅外線模組排針

(5-pin IR1)

(請參閱第 1 頁, 編號 24)

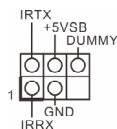

此排針支援選用的無線傳送及接收紅外線模組。

## 序列連接埠排針

(9-pin COM1)

(請參閱第 1 頁, 編號 25)

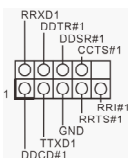

此 COM1 排針支援序列連接埠模組。

SPDIF 輸出接頭  
 (2-pin SPDIF\_OUT1)  
 (請參閱第 1 頁, 編號  
 26)



請使用纜線將 HDMI  
 VGA 卡的 SPDIF\_OUT  
 接頭接至此標頭。

TPM 標頭  
 (17-pin TPMS1)  
 (請參閱第 1 頁, 編號 13)

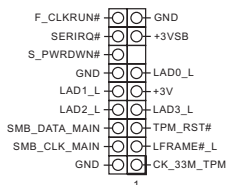

此接頭支援信賴平台模  
 組 (TPM) 系統, 可確保  
 儲存金鑰、數位憑證、  
 密碼及資料的安全。  
 TPM 系統也能強化網  
 路安全、保護數位身分  
 並確定平台完整性。

# 1 Pendahuluan

Terima kasih telah membeli motherboard ASRock Fatal1ty 990FX Killer Series, yakni motherboard andal yang diproduksi di bawah kendali mutu ketat yang sejalan dengan ASRock. Motherboard ini memberikan performa luar biasa dengan desain canggih yang meneguhkan komitmen ASRock terhadap kualitas dan ketahanan.



*Karena spesifikasi motherboard dan perangkat lunak BIOS dapat di-update, maka isi panduan pengguna ini akan berubah sewaktu-waktu tanpa pemberitahuan sebelumnya. Jika terdapat perubahan pada panduan pengguna ini, maka versi baru akan tersedia di situs web ASRock tanpa pemberitahuan lebih lanjut. Jika Anda memerlukan dukungan teknis terkait motherboard ini, kunjungi situs web kami untuk mendapatkan informasi khusus tentang model yang Anda gunakan. Anda juga dapat menemukan kartu VGA dan daftar dukungan CPU terkini di situs web ASRock. Situs web ASRock <http://www.asrock.com>.*

## 1.1 Isi Kemasan

- Motherboard ASRock Fatal1ty 990FX Killer Series (Bentuk dan Ukuran ATX)
- Panduan Ringkas ASRock Fatal1ty 990FX Killer Series
- CD Dukungan Panduan Ringkas ASRock Fatal1ty 990FX Killer Series
- 4 x Kabel Data SATA (Serial ATA) (Opsional)
- 1 x Pelindung Panel I/O
- 1 x Kartu ASRock SLI\_Bridge\_2S
- 1 x Soket 3 sekrup M.2\_SSD (NGFF)

## 1.2 Spesifikasi

- Platform**
- Bentuk dan Ukuran ATX
  - Desain Premium Gold Capacitor (100% Kapasitor Polimer Konduktif berkualitas tinggi buatan Jepang)

- A-Style**
- Purity Sound™

**Perlengkapan Permainan**

**Daya CPU**

- Soket Daya Densitas Tinggi

**Kartu VGA**

- 15µGold Finger dalam slot VGA PCIe (PCIe2/PCIe3)
- Konektor daya SLI/XFire

**Internet**

- Qualcomm® Atheros® Killer™ LAN

**Audio**

- Purity Sound™

**CPU**

- Stopkontak AM3+
- Stopkontak AM3 untuk AMD Phenom™ II X6 / X4 / X3 / X2 (kecuali 920 / 940) / Athlon II X4 / X3 / X2 / Sempron processor
- Dukungan CPUT Delapan Inti
- Mendukung fitur UCC (Unlock CPU Core)
- Desain Digi Power
- Desain Daya 8 + 2 Fase
- Mendukung CPU hingga 140 W
- Dapat digunakan AM's Cool 'n' Quiet™ Technology
- FSB 2600 MHz (5.2 GT/s)
- Menggunakan Teknologi Untied Overclocking
- Dapat digunakan Hyper-Transport 3.0 (HT 3.0) Technology

**Chipset**

- Jembatanutara: AMD 990FX
- Jembatanselatan: AMD SB950

**Memori**

- Teknologi Memori DDR3 Kanal Ganda
- 4 x Slot DDR3 DIMM
- Mendukung DDR3 2450(OC)/2100(OC)/1600/1333/1066 non-ECC, memori tanpa buffer
- Kapasitas maksimum memori sistem: 64GB
- Mendukung Intel® Extreme Memory Profile (XMP)1.3/1.2

- Mendukung Teknologi AMD Memory Profile (AMP)

### Slot Ekspansi

- 3 slot PCI Express 2.0 x16 (PCIe2/PCIe3: x16 mode; PCIe5: x4 mode)
- 2 slot PCI Express 2.0 x1
- Mendukung AMD Quad CrossFireX™, 3-Way CrossFireX™, dan CrossFireX™
- Mendukung NVIDIA® Quad SLI™ dan SLI™

### Audio

- Audio HD 7.1 CH dengan Perlindungan Konten (Realtek ALC1150 Audio Codec)
- Mendukung audio Blu-ray premium
- Mendukung Purity Sound™
  - 115dB SNR DAC dengan amplifier diferensial
  - TI® NE5532 (mendukung Premium Headset Amplifier hingga 600 Ohms)
  - Teknologi Direct Drive
  - penutup pelindung EMI
  - pelindung terisolasi PCB
- Mendukung DTS Connect

### LAN

- PCIE x1 Gigabit LAN 10/100/1000 Mb/s
- Qualcomm® Atheros® Killer™ E2200 Series
- Mendukung Wake-On-LAN
- Mendukung Energy Efficient Ethernet 802.3az
- Mendukung PXE

### Panel I/O Belakang

- 1 x Port Mouse PS/2
- 1 x Port Keyboard PS/2
- 1 x Port SPDIF Out Optik
- 5 x Port USB 2.0
- 1 x Port Fatal1ty Mouse (USB 2.0)
- 4 x Port USB 3.0 (Hub ASMedia)
- 1 x Konektor eSATA3
- 1 x Port LAN RJ-45 dengan LED (ACT/LINK LED dan SPEED LED)
- Soket Audio HD: Speaker Belakang/Tengah/Bas/Saluran masuk/Speaker Depan/Mikrofon

**Penyimpanan**

- 5 x Konektor SATA3 6,0 Gb/s, mendukung RAID (RAID 0, RAID 1, RAID 0+1, JBOD dan RAID 5), NCQ, AHCI, dan “Hot Plug”
- 1 x Soket 3 M.2\_SSD (NGFF), mendukung modul M.2 SATA3 6,0 Gb/s dan modul M.2 PCI Express hingga Soket 3 Gen2 x2 (10 Gb/s) (M.2\_SSD (NGFF) berbagi dengan konektor eSATA3)

**Konektor**

- 1 x Header IR
- 1 x Header port COM
- 1 x Header TPM
- 1 x Kepala LED daya
- 2 x Konektor kipas CPU (1 x 4-pin, 1 x 3-pin)
- 3 x Konektor kipas chassis (1 x 4-pin, 2 x 3-pin)
- 1 x Konektor kipas daya (3-pin)
- 1 x Konektor daya ATX 24 pin
- 1 x Konektor daya 12V 8 pin (Konektor Daya dengan Kerapatan Tinggi)
- 1 x Konektor daya SLI/XFire
- 1 x Konektor audio panel depan
- 1 x Konektor SPDIF Out
- 2 x Header USB 2.0 (mendukung 4 port USB 2.0)
- 1 x USB 3.0 Vertikal Tipe A
- 1 x Header Etron EJ188 USB 3.0 (mendukung 2 port USB 3.0)

**Fitur BIOS**

- 32Mb AMI UEFI Legal BIOS dengan dukungan GUI
- Menggunakan “Plug and Play”
- ACPI 1.1 Kompatibel dengan Aktivitas Pengaktifan
- Menggunakan jumperfree
- Dukungan SMBIOS 2.3.1
- Multipengatur Tegangan CPU, DRAM, NB, HT, CPU VDDA, PCIE VDDA, CPU NB

**Dukungan CD**

- Driver, Utilitas, Perangkat Lunak AntiVirus (Versi Uji Coba), Browser dan Toolbar Google Chrome, Start8 (uji coba 30 hari), XSplit, Killer Network Manager

**Perangkat  
Keras Monitor**

- Sensor Suhu CPU/Chassis
- Takometer CPU/Chassis/Kipas Daya
- Kipas Hening CPU/Chassis (Memungkinkan Penyesuaian Otomatis Kecepatan Kipas Chassis Berdasarkan Suhu CPU)
- Kontrol Multikecepatan Kipas CPU/Chassis
- Pemantauan Tegangan: +12V, +5V, +3,3V, CPU Vcore

**OS**

- Microsoft® Windows® 10 64-bit / 8.1 32-bit / 8.1 64-bit / 8 32-bit / 8 64-bit / 7 32-bit / 7 64-bit

**Sertifikasi**

- FCC, CE, WHQL
- Siap untuk ErP/EuP (memerlukan catu daya untuk ErP/EuP)

\* Untuk informasi rinci tentang produk, kunjungi situs web kami: <http://www.asrock.com>

## Contact Information

If you need to contact ASRock or want to know more about ASRock, you're welcome to visit ASRock's website at <http://www.asrock.com>; or you may contact your dealer for further information. For technical questions, please submit a support request form at <http://www.asrock.com/support/tsd.asp>

### **ASRock Incorporation**

2F., No.37, Sec. 2, Jhongyang S. Rd., Beitou District,

Taipei City 112, Taiwan (R.O.C.)

### **ASRock EUROPE B.V.**

Bijsterhuizen 3151

6604 LV Wijchen

The Netherlands

Phone: +31-24-345-44-33

Fax: +31-24-345-44-38

### **ASRock America, Inc.**

13848 Magnolia Ave, Chino, CA91710

U.S.A.

Phone: +1-909-590-8308

Fax: +1-909-590-1026