



**BIGASS**<sup>®</sup>  
FANS

*No Equal*<sup>™</sup>

# INSTALLATION GUIDE

---

Powerfoil<sup>®</sup>X2.0  
Washdown

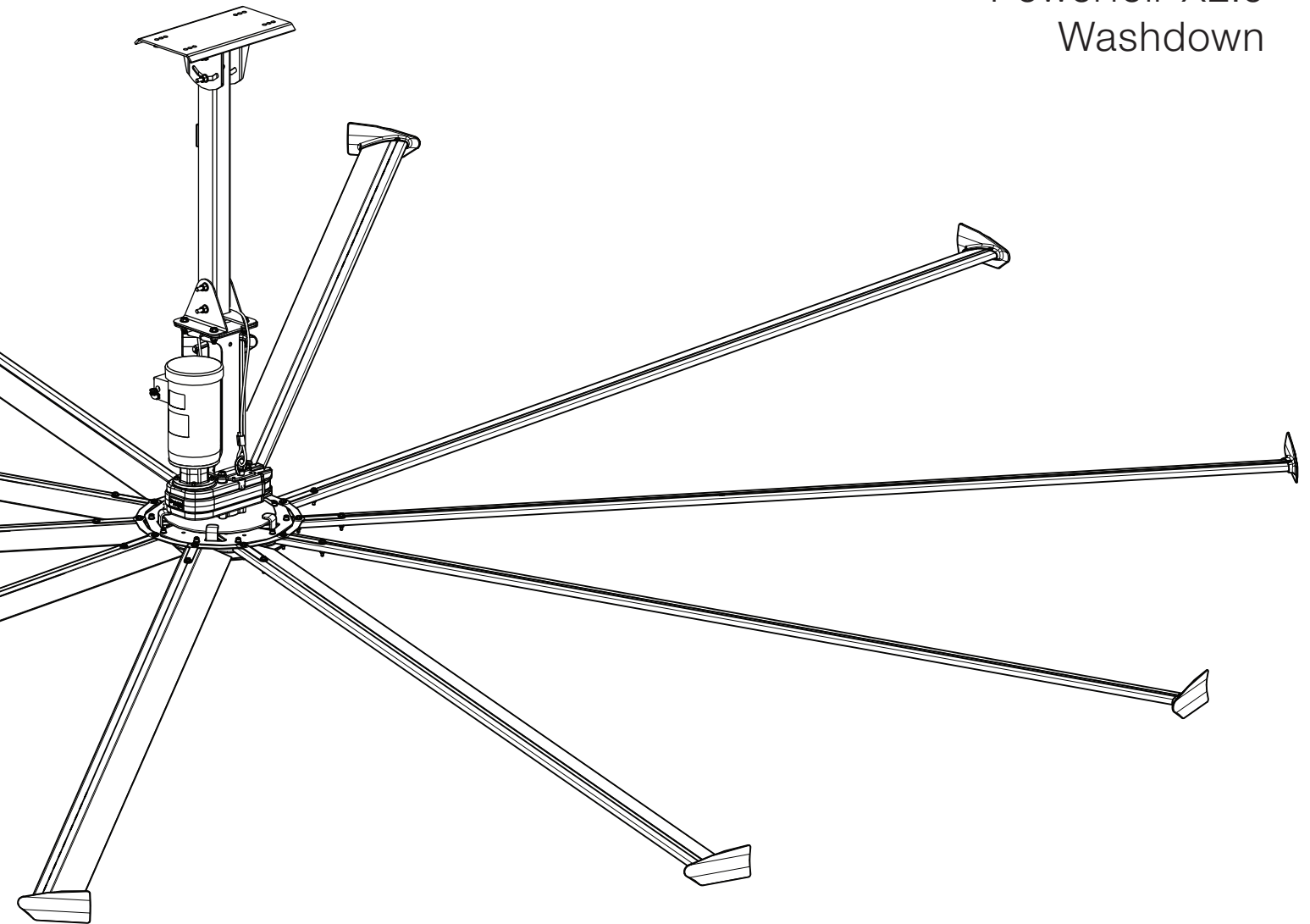

For help, call 1-877-BIG-FANS  
or visit [www.bigassfans.com](http://www.bigassfans.com)

# Installation Checklist

**Do you have the appropriate mount to accommodate your roof pitch?** If you are uncertain or feel you have the incorrect mount for your building structure, please contact Customer Service.

**Did a structural engineer approve the mounting structure?** See page 9 for Big Ass Fans-approved mounting structures.

**Are you familiar with the function and use of the safety cable?** See page 19 for information on properly securing the safety cable.

**Will the fan be installed so that the airfoils are at least 10 ft (3.05 m) above the floor?**

**Will the fan be installed so that the airfoils have at least 2 ft (0.61 m) of clearance from obstructions?**

**Will the fan be installed so that it is not subjected to high winds such as from an HVAC system or near a large garage door?** If the fan is mounted at the same level or higher than a diffuser, the winglets must be at a distance that is at least 1x the measure of the fan's diameter. If the fan is mounted at the same height or below a diffuser, the winglets must be at a distance that is at least 2x the measure of the fan's diameter.

**Will the distance between multiple fans be at least 2.5x the fans' diameter when measured from the centers of the fans.**

**If installing the fan on an I-beam, ensure the upper yoke is the correct size.** See page 12 for more information on installing the fan to an I-beam.

**If you ordered multiple fans, did you keep the parts for each fan together?** It is critical that the airfoils be properly matched with the motor unit.

**Do you have the correct power circuit for the fan controller?** See pages 2–3 for information concerning power requirements for the fan controller.

**Customer Service: 1-877-BIG-FANS**  
(International: +1 859 233 1271)

# Installation Guide

## 8'-24' Powerfoil® X2.0 Washdown

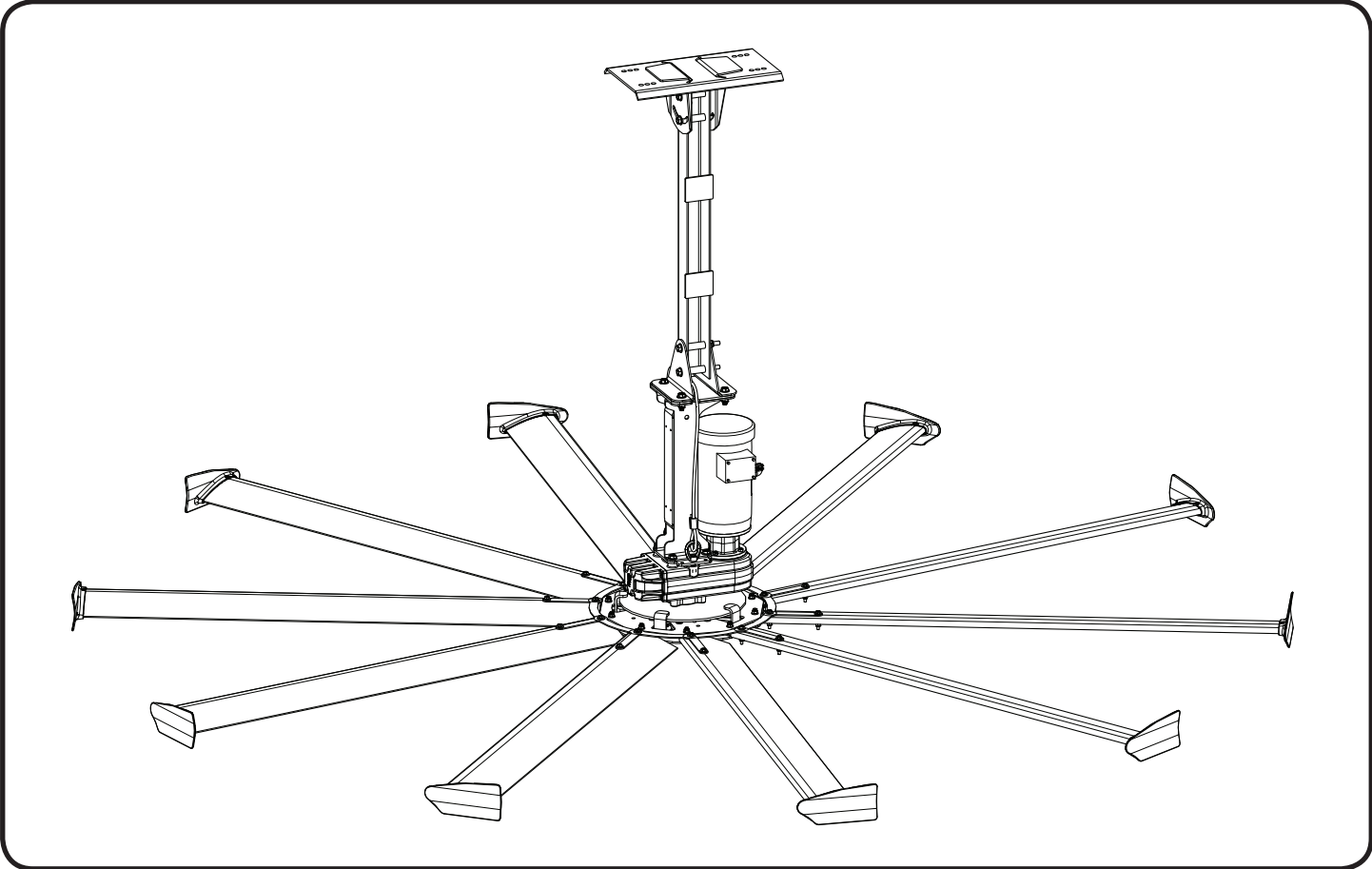

Installation Guide:  
Apr. 2015  
Rev. J



This product was manufactured in a plant whose Management System is certified as being in conformity with ISO 9001:2008.



Conforms to ANSI/UL STD 507: Electric Fans  
Certified to CAN/CSA C22.2 No.113: Fans & Ventilators

### Contact Information

**Manufacturing**  
2425 Merchant Street  
Lexington, KY 40511  
1-877-BIG-FANS  
www.bigassfans.com

**Customer Service**  
2348 Innovation Drive  
Lexington, KY 40511  
1-877-BIG-FANS  
Intl.: +1 859 233 1271  
www.bigassfans.com

**Warranty Returns**  
800 Winchester Road  
Lexington, KY 40505  
1-877-BIG-FANS  
www.bigassfans.com

**Australia Office**  
Unit 22, 1029 Manly Road  
Tingalpa QLD 4173, Australia  
(07) 3292 0100  
www.bigassfans.com/au

Powerfoil X2.0 and the Powerfoil X2.0 logo are trademarks of Delta T Corporation, registered in the United States and/or other countries. All other trademarks used herein are the properties of their respective owners. No part of this document may be reproduced or translated into a different language without the prior written consent of Big Ass Fan Company. The information contained in this document is subject to change without notice.

www.bigasssolutions.com/patents



## IMPORTANT SAFETY INSTRUCTIONS READ AND SAVE THESE INSTRUCTIONS

TO REDUCE THE RISK OF FIRE, ELECTRIC SHOCK, OR INJURY TO PERSONS, OBSERVE THE FOLLOWING:

**WARNING:** Before servicing or cleaning unit, switch power off at service panel and lock the service disconnecting means to prevent power from being switched on accidentally. When the service disconnecting means cannot be locked, securely fasten a prominent warning device, such as a tag, to the service panel.

**WARNING:** Big Ass Fans must be installed with Big Ass Fan-supplied controllers. Other parts cannot be substituted.

**CAUTION:** The installation of a Big Ass Fan must be in accordance with the requirements specified in this installation manual and with any additional requirements set forth by the National Electric Code (NEC), ANSI/NFPA 70-2011, and all local codes. Code compliance is ultimately YOUR responsibility! Failure to comply with these codes could result in personal injury or property damage.

**WARNING:** The fan controllers contain high voltage capacitors which take time to discharge after removal of mains supply. Before servicing the fan controller, ensure isolation of mains supply from line inputs at the controller. Wait three minutes for capacitors to discharge to safe voltage levels. Failure to do so may result in personal injury or death. Note: Darkened display LEDs are not an indication of safe voltage levels.

**CAUTION:** Exercise caution and common sense when powering the fan. Do not connect the fan to a damaged or hazardous power source. Do not attempt to resolve electrical malfunctions or failures on your own. Contact Big Ass Fans if you have any questions regarding the electrical installation of this fan.

**CAUTION:** When service or replacement of a component in the fan requires the removal or disconnection of a safety device, the safety device is to be reinstalled or remounted as previously installed.

**WARNING:** Risk of fire, electric shock, or injury to persons during cleaning and user-maintenance! Disconnect the fan from the power supply before servicing.

**CAUTION:** Do not bend the airfoils when installing, adjusting, or cleaning the fan. Do not insert foreign objects between rotating fan airfoils.

**WARNING:** Stay alert, watch what you are doing, and use common sense when installing fans. Do not install fans if tired or under the influence of drugs, alcohol, or medication. A moment of inattention while installing fans may result in serious personal injury.

**CAUTION:** Installation work and electrical wiring must be done by qualified person(s) in accordance with all applicable codes and standards.

**CAUTION:** Use this fan only in the manner intended by the manufacturer. If you have questions, contact the manufacturer.

**CAUTION:** The installation of this fan requires the use of some power tools. Follow the safety procedures found in the owner's manual for each of these tools and do not use them for purposes other than those intended by the manufacturer.

**CAUTION:** The Big Ass Fans product warranty will not cover equipment damage or failure that is caused by improper installation.

**CAUTION:** Do not operate fan with a damaged cord or plug. Return fan to an authorized service facility for examination or repair.

**WARNING:** This appliance is not intended for use by persons (including children) with reduced physical, sensory or mental capabilities, or lack of experience and knowledge, unless they have been given supervision or instruction concerning use of the appliance by a person responsible for their safety. Children should be supervised to ensure that they do not play with the appliance.

Leave this installation guide with the owner of the fan after installation.

Suitable for use in wet locations and outdoor use when installed in a GFCI protected branch circuit.

**ATTENTION:** If installing the fan in the United States, the fan must be installed per the following National Fire Protection Association (NFPA) guidelines:

- The fan must be centered approximately between four adjacent sprinklers.
- The vertical distance from the fan to the sprinkler deflector must be at least 3 ft (91.4 cm).
- The fan must be interlocked to shut down immediately upon receiving a waterflow signal from the alarm system.

# Mounting Reference Guide

The following is intended as a reference guide for Powerfoil®X2.0 Washdown and Powerfoil®X2.0Plus Washdown fan mounting methods. See the referenced pages for complete fan installation and operating instructions. Consult a structural engineer to determine which mounting method best suits your building structure.

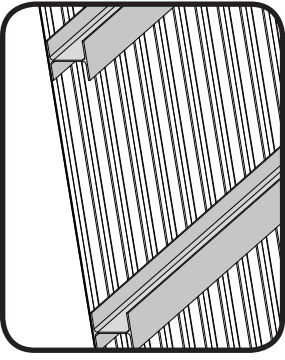
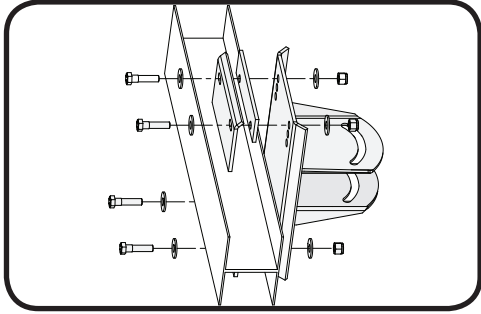
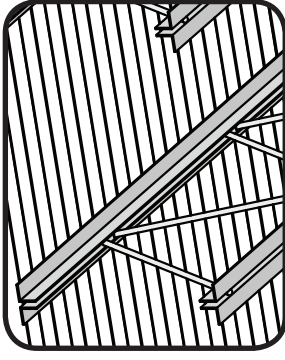
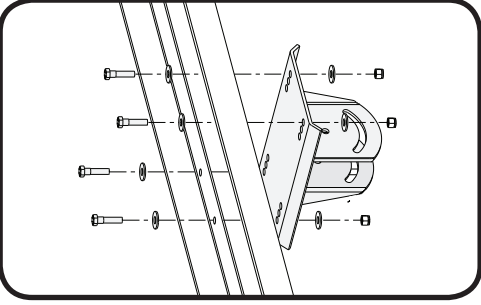
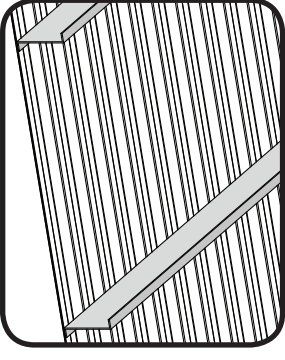
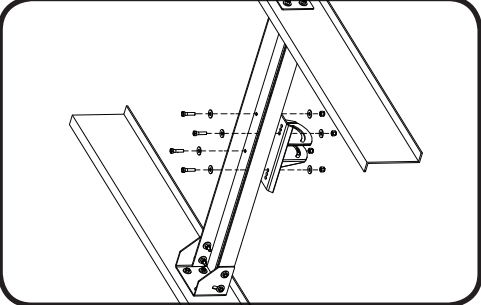
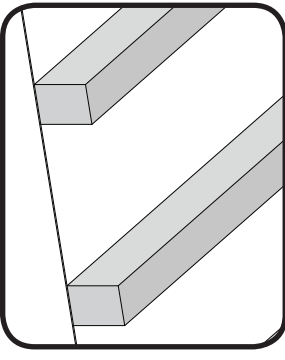
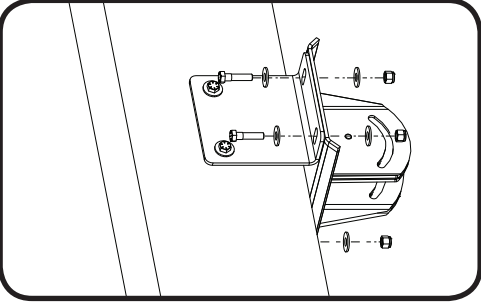
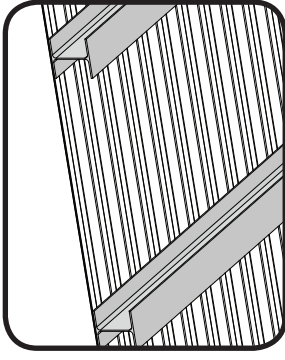
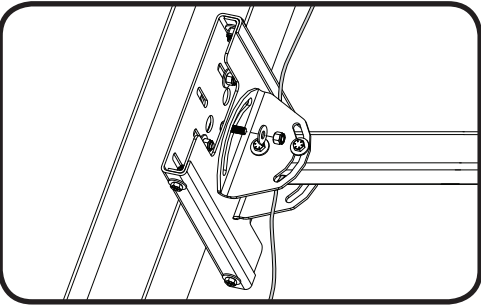
 <p><b>I-Beam</b></p>	➔		See page 12 for mounting instructions.
 <p><b>Bar Joists</b></p>	➔		See page 13 for mounting instructions.
 <p><b>Z-Purlins</b></p>	➔		See complete instructions included with the Z-Purlin Installation Kit.
 <p><b>Solid Beam</b></p>	➔		See complete instructions included with the L-Bracket Installation Kit.
 <p><b>I-Beam (Angled)</b></p>	➔		See complete instructions included with the Compound Angle Mount Installation Kit.



# Contents

<b>Introduction</b>	Safety Instructions.....	ii
	Mounting Reference Guide.....	iii
	Thank You.....	1
	About Big Ass Fans.....	1
	About the Fan.....	1
	Technical Specifications.....	2
<b>Pre-Installation</b>	What's in the Box.....	4
	Parts and Hardware.....	5
	Tools Needed.....	6
	Understanding Roof Pitch.....	6
	Fan Diagram.....	7
	Controller Diagram.....	8
	Preparing the Work Site.....	9
Understanding Airflow Patterns.....	10	
<b>Mounting Structure: I-Beam</b>	Attach Upper Yoke (to I-Beam).....	12
<b>Mounting Structure: Bar Joists</b>	1. Select Proper Angle Irons.....	13
	2. Pre-drill Angle Irons.....	14
	3. Secure Angle Irons (span is longer than 8 ft).....	14
	4a. Fasten Single Angle Irons to Roof Structure.....	15
	4b. Fasten Double Angle Irons to Roof Structure.....	16
	5a. Attach Upper Yoke (to Angle Irons).....	17
	5b. Attach Main Fan Unit (to Angle Irons).....	18
<b>Hanging the Fan</b>	1. Attach Extension Tube (to Upper Yoke).....	19
	2. Secure Upper Safety Cable.....	19
	3. Attach Lower Yoke (to Extension Tube).....	20
	4. Attach Main Fan Unit (to Lower Yoke).....	20
	5. Confirm Orientation.....	20
<b>Installing Guy Wires</b>	1. Attach Locking Carabiners to Main Fan Unit.....	21
	2. Attach Beam Clamp.....	21
	3. Route Guy Wire through Gripple®.....	23
	4. Install Remaining Guy Wires.....	23
<b>Installing Airfoils</b>	1. Attach Winglets to Airfoils.....	24
	2. Position Airfoils.....	24
	3. Attach Airfoils to Hub.....	25
<b>Electrical Installation</b>	Safety Guidelines.....	26
	Delta Secondary.....	27
	Branch Circuit Protection.....	28
	Mounting the Variable Frequency Drive (VFD).....	29
	Wiring: Fan Controller (200V–250V Single-Phase, 1 HP).....	30
	Wiring: Fan Controller (200V–250V Single-Phase, 2 HP).....	31
	Wiring: Fan Controller (200V–250V Three-Phase, 1 HP & 2 HP).....	32
	Wiring: Fan Controller (400V–480V Three-Phase, 1 HP & 2 HP).....	33
	Wiring: Fan Motor.....	34
	Daisy Chaining.....	35
	Basic Distributed I/O Interface; LOCAL Control.....	37
	Basic Distributed I/O Interface; EXTERNAL Control.....	38
	Interfacing with Basic Timers, Thermostats, and Other Equipment.....	39
	Controller Operation.....	41
	Starting, Stopping, and Direction Control.....	41
	Changing the Fan Speed.....	41
Cycling through the LED Display Modes.....	42	

## Contents (cont.)

<b>Electrical Installation (cont.)</b>	Toggling the Fan's Command Source.....	42
	Understanding and Clearing Fan Faults.....	43
	Programming and Parameter Changes.....	43
	Locking and Unlocking Procedures.....	44
<b>Operating the Fan</b>	Heating Season.....	46
	Cooling Season.....	46
<b>Preventive Maintenance</b>	Annual Preventive Maintenance.....	47
	General Preventive Maintenance.....	47
	Annual Maintenance Checklist.....	49
<b>Troubleshooting</b>	General Troubleshooting.....	51
	E Series Fan Error Codes.....	52
	M Series Fan Error Codes.....	54
<b>Warranty Return Instructions</b>	Return Instructions.....	56
	Warranty Claim Form Instructions.....	57
	Warranty Claim Form.....	59
	Responsibility Agreement.....	60
<b>Big Ass Fan Certified Installers</b>	Check-In Procedure.....	61
	Close-Out Procedure.....	63



# Introduction

1

Thank you and congratulations on your purchase of a Big Ass Fan, an efficient and cost-effective way to stay cool in the summer and warm in the winter. The revolutionary design of our fans combines the best of both form and function to bring power performance and a sleek look to any setting. More importantly, you have purchased a product that is backed by extensive research, thorough testing, and quality manufacturing. We're ready to answer any questions or comments at 1-877-BIG-FANS or visit our Web site at [www.bigassfans.com](http://www.bigassfans.com).

## Who we are and what we do

---

Big Ass Fans has been the preeminent manufacturer of large-diameter, low-speed fans since 1999. With a worldwide presence and located in beautiful Lexington, KY, we research, design, and manufacture the most effective air movement solutions on the market. Our never-ending commitment to quality and innovation keeps us at the leading edge of a burgeoning industry. With an eye to helping customers satisfy their needs, and a strong sense of corporate responsibility to the community, Big Ass Fans has redefined the way business is done.

## About the fan

---

The Powerfoil® X2.0 Washdown is the first and only fan of its kind, developed in direct response to requests from food manufacturers for an air-movement solution that would meet the needs of the strictest food processing facilities. Features and benefits of the Powerfoil X2.0 Washdown include:

- Stainless steel and aluminum components
- Stainless steel, washdown motor for frequent intense cleaning
- Food duty epoxy
- Completely sealed NitroSeal gearbox with food-grade oil
- Nonporous, nonabsorbent, and corrosion-resistant materials

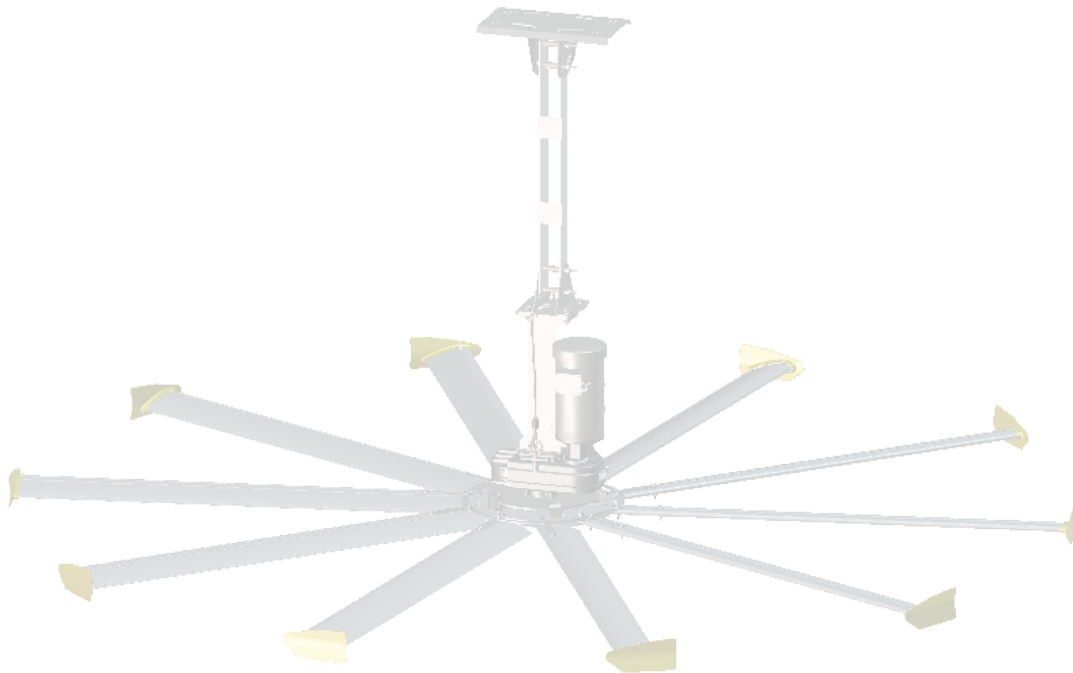

## Powerfoil® X2.0 specifications

Fan size	Motor size, HP (kW)	Minimum required supply circuit size	Nominal output voltage, 3 $\Phi$ <sup>1</sup>	Maximum full load current	Max RPM	Airfoil length	Suggested distance from ceiling <sup>2</sup>
8 ft (2.4 m)	1.0 (0.75)	20 A @ 200–250 V, 1 $\Phi$ 10 A @ 200–250 V, 3 $\Phi$ 10 A @ 400–480 V, 3 $\Phi$ 10 A @ 575–600 V, 3 $\Phi$	240 V 240 V 480 V 600 V	4.4 A 3.2 A 1.5 A 1.3 A	113 RPM	37.5 in (1 m)	4 ft (1.2 m)
10 ft (3 m)	1.0 (0.75)	20 A @ 200–250 V, 1 $\Phi$ 10 A @ 200–250 V, 3 $\Phi$ 10 A @ 400–480 V, 3 $\Phi$ 10 A @ 575–600 V, 3 $\Phi$	240 V 240 V 480 V 600 V	4.4 A 3.2 A 1.5 A 1.3 A	113 RPM	49.5 in (1.26 m)	4 ft (1.2 m)
12 ft (3.6 m)	1.0 (0.75)	20 A @ 200–250 V, 1 $\Phi$ 10 A @ 200–250 V, 3 $\Phi$ 10 A @ 400–480 V, 3 $\Phi$ 10 A @ 575–600 V, 3 $\Phi$	240 V 240 V 480 V 600 V	4.4 A 3.2 A 1.5 A 1.3 A	106 RPM	61.5 in (1.56 m)	5 ft (1.5 m)
14 ft (4.3 m)	1.5 (1.1)	30 A @ 200–250 V, 1 $\Phi$ 20 A @ 200–250 V, 3 $\Phi$ 10 A @ 400–480 V, 3 $\Phi$ 10 A @ 575–600 V, 3 $\Phi$	240 V 240 V 480 V 600 V	8.7 A 5.0 A 2.5 A 1.9 A	95 RPM	73.5 in (1.87 m)	5 ft (1.5 m)
16 ft (4.9 m)	1.5 (1.1)	30 A @ 200–250 V, 1 $\Phi$ 20 A @ 200–250 V, 3 $\Phi$ 10 A @ 400–480 V, 3 $\Phi$ 10 A @ 575–600 V, 3 $\Phi$	240 V 240 V 480 V 600 V	8.7 A 5.0 A 2.5 A 1.9 A	95 RPM	85.5 in (2.17 m)	6 ft (1.8 m)
18 ft (5.5 m)	1.5 (1.1)	30 A @ 200–250 V, 1 $\Phi$ 20 A @ 200–250 V, 3 $\Phi$ 10 A @ 400–480 V, 3 $\Phi$ 10 A @ 575–600 V, 3 $\Phi$	240 V 240 V 480 V 600 V	8.7 A 5.0 A 2.5 A 1.9 A	77 RPM	97.5 in (2.48 m)	6 ft (1.8 m)
20 ft (6.1 m)	2.0 (1.5)	30 A @ 200–250 V, 1 $\Phi$ 20 A @ 200–250 V, 3 $\Phi$ 10 A @ 400–480 V, 3 $\Phi$ 10 A @ 575–600 V, 3 $\Phi$	240 V 240 V 480 V 600 V	10.7 A 6.2 A 3.0 A 2.3 A	70 RPM	109.5 in (2.78 m)	7 ft (2.1 m)
24 ft (7.3 m)	2.0 (1.5)	30 A @ 200–250 V, 1 $\Phi$ 20 A @ 200–250 V, 3 $\Phi$ 10 A @ 400–480 V, 3 $\Phi$ 10 A @ 575–600 V, 3 $\Phi$	240 V 240 V 480 V 600 V	10.7 A 6.2 A 3.0 A 2.3 A	55 RPM	133.5 in (3.39 m)	7 ft (2.1 m)

1. Output voltage will not exceed Input voltage, with the exception of 120 V models. All controllers produce 3  $\Phi$  output power, regardless of input phase.
2. The distance of the fan from the ceiling should be measured from the top of the winglets to the ceiling.

**⚠ CAUTION: Big Ass Fans requires that the Powerfoil X2.0 fan be supplied from one of the following types of transformers:**

**575–600 V models: 575/330 V Wye secondary (neutral not utilized)**

**400–480 V models: 480/277 V Wye secondary (neutral not utilized)**

**200–250 V models: 208/120 V Wye secondary (neutral not utilized)**

**240/120 V Delta secondary (Wild/High Phase B)**

Integration into any other power distribution scheme may result in improper fan operation or premature hardware failure! See page 26 for more information.

## Powerfoil® X2.0 Plus specifications

Fan size	Motor size, hp (kW)	Minimum required supply circuit size	Nominal output voltage, 3 $\Phi$ <sup>1</sup>	Maximum full load current	Max RPM	Airfoil length	Suggested distance from ceiling <sup>2</sup>
10 ft (3 m)	1.0 (0.75)	20 A @ 200–250 V, 1 $\Phi$ 10 A @ 200–250 V, 3 $\Phi$ 10 A @ 400–480 V, 3 $\Phi$ 10 A @ 575–600 V, 3 $\Phi$	240 V 240 V 480 V 600 V	4.4 A 3.2 A 1.5 A 1.3 A	115 RPM	49.5 in (1.26 m)	5 ft (1.5 m)
12 ft (3.6 m)	1.5 (1.1)	30 A @ 200–250 V, 1 $\Phi$ 20 A @ 200–250 V, 3 $\Phi$ 10 A @ 400–480 V, 3 $\Phi$ 10 A @ 575–600 V, 3 $\Phi$	240 V 240 V 480 V 600 V	8.7 A 5.0 A 2.5 A 1.9 A	95 RPM	61.5 in (1.56 m)	6 ft (1.8 m)
14 ft (4.3 m)	1.5 (1.1)	30 A @ 200–250 V, 1 $\Phi$ 20 A @ 200–250 V, 3 $\Phi$ 10 A @ 400–480 V, 3 $\Phi$ 10 A @ 575–600 V, 3 $\Phi$	240 V 240 V 480 V 600 V	8.7 A 5.0 A 2.5 A 1.9 A	95 RPM	73.5 in (1.87 m)	6 ft (1.8 m)
16 ft (4.9 m)	1.5 (1.1)	30 A @ 200–250 V, 1 $\Phi$ 20 A @ 200–250 V, 3 $\Phi$ 10 A @ 400–480 V, 3 $\Phi$ 10 A @ 575–600 V, 3 $\Phi$	240 V 240 V 480 V 600 V	8.7 A 5.0 A 2.5 A 1.9 A	77 RPM	85.5 in (2.17 m)	7 ft (2.1 m)
18 ft (5.5 m)	2.0 (1.5)	30 A @ 200–250 V, 1 $\Phi$ 20 A @ 200–250 V, 3 $\Phi$ 10 A @ 400–480 V, 3 $\Phi$ 10 A @ 575–600 V, 3 $\Phi$	240 V 240 V 480 V 600 V	10.7 A 6.2 A 3.0 A 2.3 A	70 RPM	97.5 in (2.48 m)	7 ft (2.1 m)
20 ft (6.1 m)	2.0 (1.5)	30 A @ 200–250 V, 1 $\Phi$ 20 A @ 200–250 V, 3 $\Phi$ 10 A @ 400–480 V, 3 $\Phi$ 10 A @ 575–600 V, 3 $\Phi$	240 V 240 V 480 V 600 V	10.7 A 6.2 A 3.0 A 2.3 A	58 RPM	109.5 in (2.78 m)	8 ft (2.4 m)
24 ft (7.3 m)	2.0 (1.5)	30 A @ 200–250 V, 1 $\Phi$ 20 A @ 200–250 V, 3 $\Phi$ 10 A @ 400–480 V, 3 $\Phi$ 10 A @ 575–600 V, 3 $\Phi$	240 V 240 V 480 V 600 V	10.7 A 6.2 A 3.0 A 2.3 A	48 RPM	133.5 in (3.39 m)	8 ft (2.4 m)

1. Output voltage will not exceed Input voltage, with the exception of 120 V models. All controllers produce 3  $\Phi$  output power, regardless of input phase.
2. The distance of the fan from the ceiling should be measured from the top of the winglets to the ceiling.

**⚠ CAUTION: Big Ass Fans requires that the Powerfoil X2.0 Plus fan be supplied from one of the following types of transformers:**

**575V–600 V models: 575/330V Wye secondary (neutral not utilized)**

**400V–480 V models: 480/277V Wye secondary (neutral not utilized)**

**200V–250 V models: 208/120V Wye secondary (neutral not utilized)**

**240/120V Delta secondary (Wild/High Phase B)**

**Integration into any other power distribution scheme may result in improper fan operation or premature hardware failure! See page 26 for more information.**

## 4

## Pre-Installation

## What's in the box

If you ordered multiple fans, be sure to keep the components of each fan together. The fans each have differently rated components that are not interchangeable.

The fan is shipped in multiple boxes. Refer to the illustrations below. If the extension tube is 4 ft or longer, it will be shipped in a separate box. All accessories are shipped in separate boxes. This installation guide should remain with the owner of the fan.

*Note: Dashed lines indicate internal boxes. The drawings below are not to scale.*

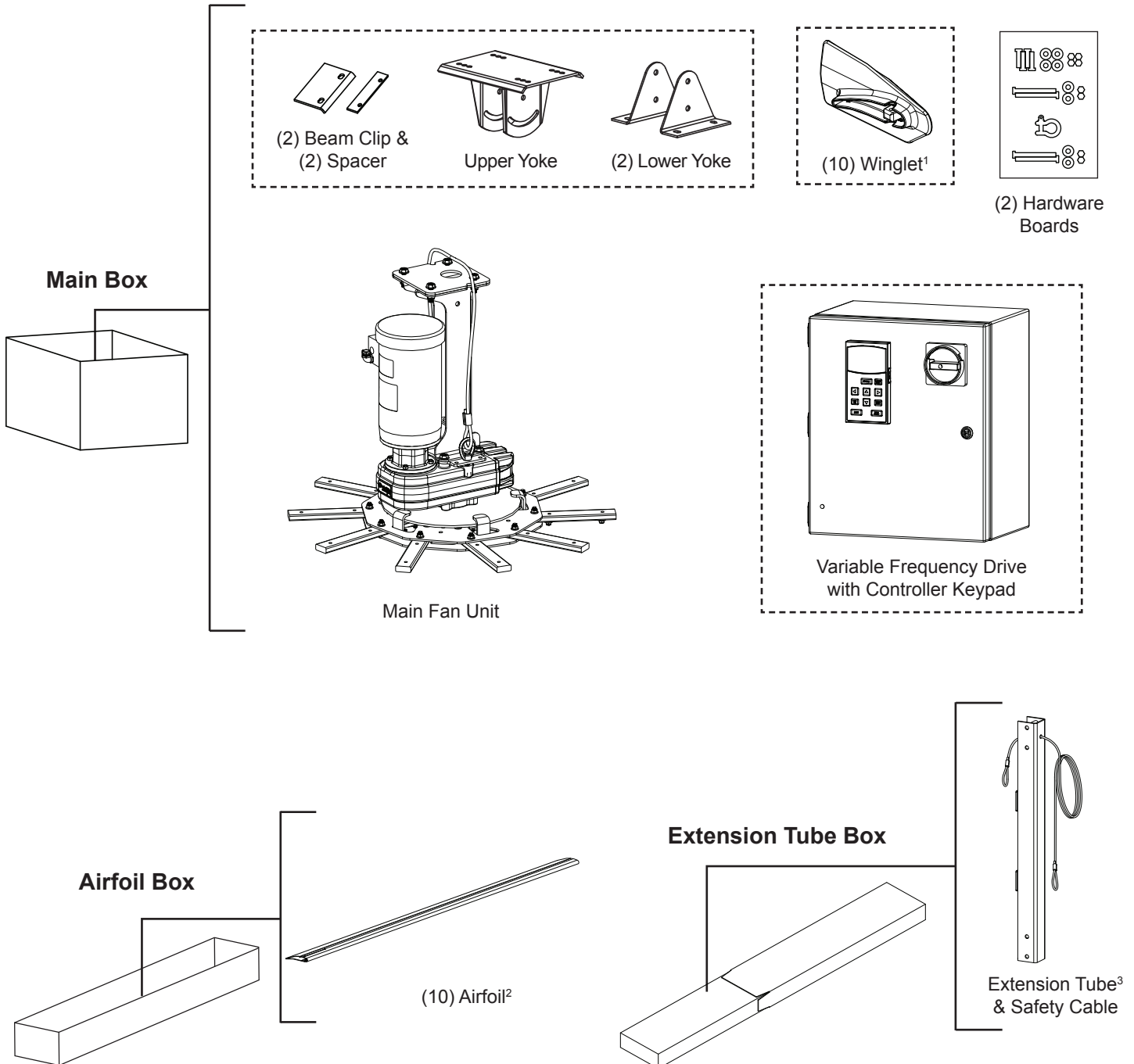

1. Powerfoil® winglet shown. Powerfoil or PowerfoilPlus winglets are available.

2. Airfoil retainers are packed in a bag with the Installation Guide.





3. The safety cable is attached to the extension tube. If the extension tube is 4 ft or longer, it will be shipped in a separate box. Guy wires (if ordered) are bagged separately in main box.

## Pre-Installation (cont.)



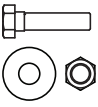
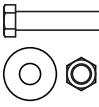
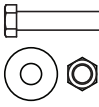
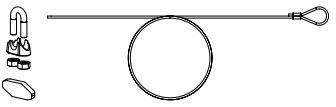

### Parts and hardware

Note: The drawings below are not to scale. No hardware substitutions are acceptable.

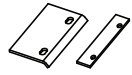

#### Hardware

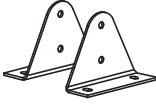
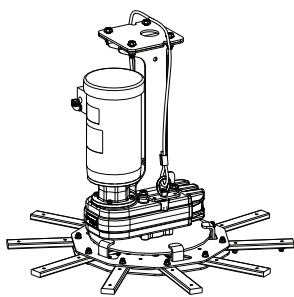
			
<b>Upper Yoke Hardware</b> (4) 1/2-13 x 2" GR 8 Bolt (8) 1/2" Flat Washer (4) 1/2-13 Nylock Nut	<b>Extension Tube Hardware</b> (2) 1/2-13 x 4-1/2" GR 8 Bolt (4) 1/2" Flat Washer (2) 1/2-13 Nylock Nut	<b>Lower Yoke Hardware</b> (2) 1/2-13 x 4-1/2" GR 8 Bolt (4) 1/2" Flat Washer (2) 1/2-13 Nylock Nut	<b>Guy Wire Hardware<sup>1</sup></b> (8) Locking Carabiner (4) 1/4" Beam Clip (4) 1/4-20 x 1" Eyebolt (4) 1/4-20 Hex Nut (4) Gripple® (4) Guy Wire (16) Wire Rope Clip
			
<b>Winglet Hardware</b> (10) 10-24 x 1/2" Bolt (10) 10-24 x 3/4" Barrel	<b>Airfoil Hardware</b> (20) 5/16-18 x 2" GR 8 Bolt (40) 5/16" Flat Washer (20) 5/16-18 Nylock Nut	<b>Main Fan Unit Hardware</b> (4) 1/2-13 x 1 3/4" GR 8 Bolt (8) 1/2" Flat Washer (4) 1/2-13 Nylock Nut	

#### Mounting

		
(2) Beam Clip & Spacer	Upper Yoke <sup>2</sup>	(2) Lower Yoke
		
Main Fan Unit & Hub Cover		Extension Tube, Safety Cable <sup>4</sup> , & Shackle <sup>6</sup>

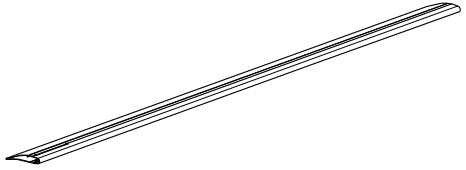
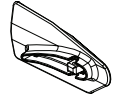
#### Airfoils

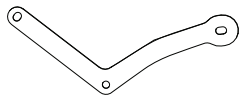
	
(10) Airfoils	
	or 
(10) Powerfoil® Winglets <sup>3</sup>	(10) Powerfoil®Plus Winglets <sup>3</sup>
	
(10) Airfoil Retainers	

#### Electrical

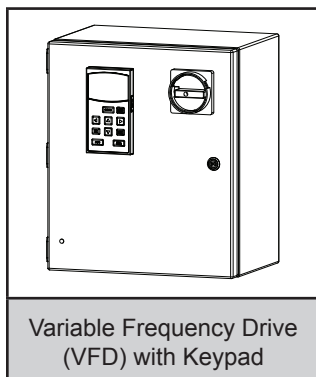

1. Guy wires are designed to constrain fan's lateral movement and are only included in some fan packages. Big Ass Fans recommends using guy wires if the fan's extension tube is 4 ft or longer, if the fan is exposed to high winds or similar conditions, or if the fan is close to any building fixtures. Guy Wire hardware is bagged separately from hardware boards.
2. Ensure you have the correct upper yoke for your mounting method. The upper yoke may differ from the illustration.
3. Powerfoil winglets are standard. PowerfoilPlus winglets are only included if ordered.
4. Safety cable is attached to extension tube.
5. Shackle included on hardware boards.

## 6

## Pre-Installation (cont.)

## Tools needed

Big Ass Fans recommends gathering the following tools prior to beginning installation. *Note: This list of suggested tools is not exhaustive. Additional tools may be necessary.*

Mechanical installation
Standard wrench set
Standard socket set with ratchet
Torque wrench capable of 40 ft·lb (54.2 N·m)
Phillips and flat head screwdriver
Standard allen wrench set

Electrical installation
Phillips and flat head screwdriver
1/4" nut driver
5/16" nut driver
Pair of #10 to #14AWG strippers
Pair of medium channel locks
Multimeter

## Understanding roof pitch

**Before beginning installation, confirm that you have the appropriate mount for your roof pitch.**

To ensure the fan is properly mounted, the fan must always hang plumb to the ground and the yoke must be installed using the bolt holes at the widest locations possible. To accommodate building structures on which the standard upper yoke does not allow the fan to properly orient itself, the 90-Degree Offset mount should be purchased.

The example below shows one situation in which the 90-Degree Offset mount must be used so that the fan hangs plumb to the ground and the widest stance for the upper yoke is ensured. If you are uncertain of your roof pitch or do not have the correct mount to properly hang your fan, consult a structural engineer or contact Big Ass Fans Customer Service.

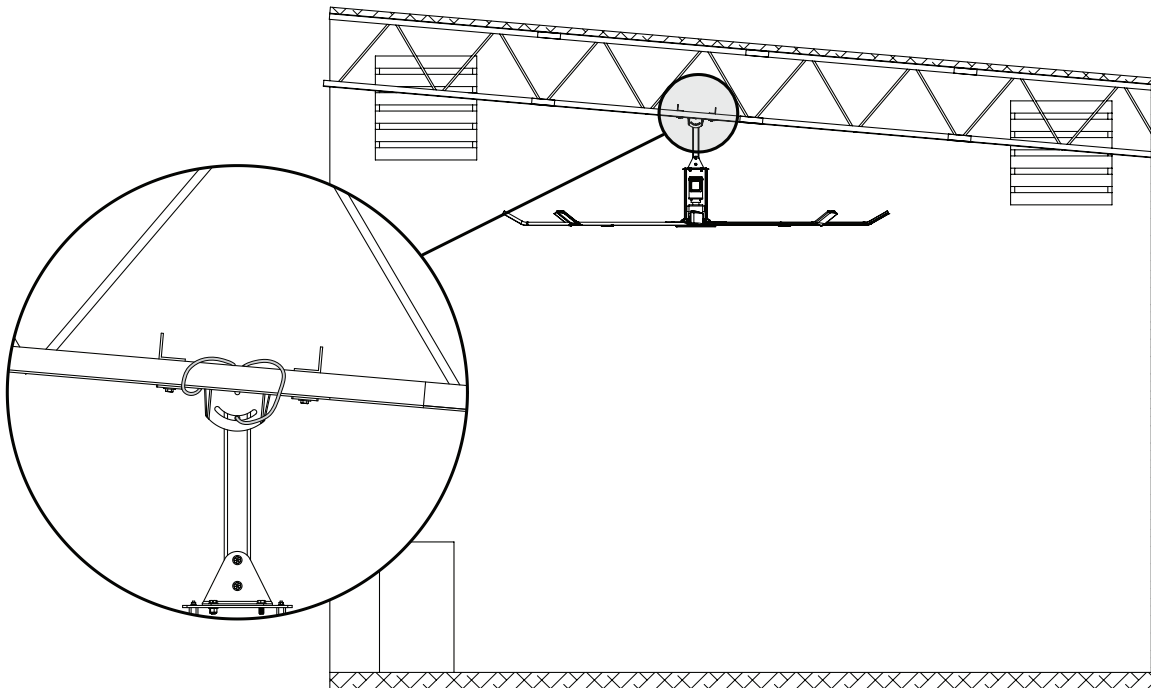

Standard Upper Yoke

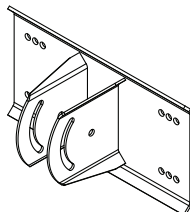

90-Degree Offset Mount

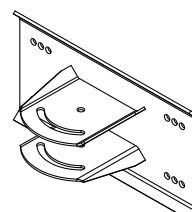

## Fan diagram

- A. Safety Cable.** A redundant safety feature that secures the fan to the mounting structure.
- B. Upper Yoke.** Secures the fan to the mounting structure and allows the fan to adjust its center of gravity.
- C. Extension Tube.** Extends the fan from the ceiling.
- D. Lower Yoke.** Connects the main fan assembly to the extension tube.
- E. VFD Enclosure (not shown).** Contains the variable-frequency drive with the controller keypad mounted on the front of the enclosure.
- F. Gearbox.** NitroSeal Drive™ custom gearbox for increased durability and cooler operation.
- G. Motor.** See pages 2–3 for more information.
- H. Hub.** Secures the airfoils to the gearbox output shaft.
- I. Airfoil.** Provides air movement. The unique, patented design provides efficient and effective air movement.
- J. Winglet (Powerfoil® [shown] or Powerfoil®Plus).** Improves the efficiency and performance of the fan.

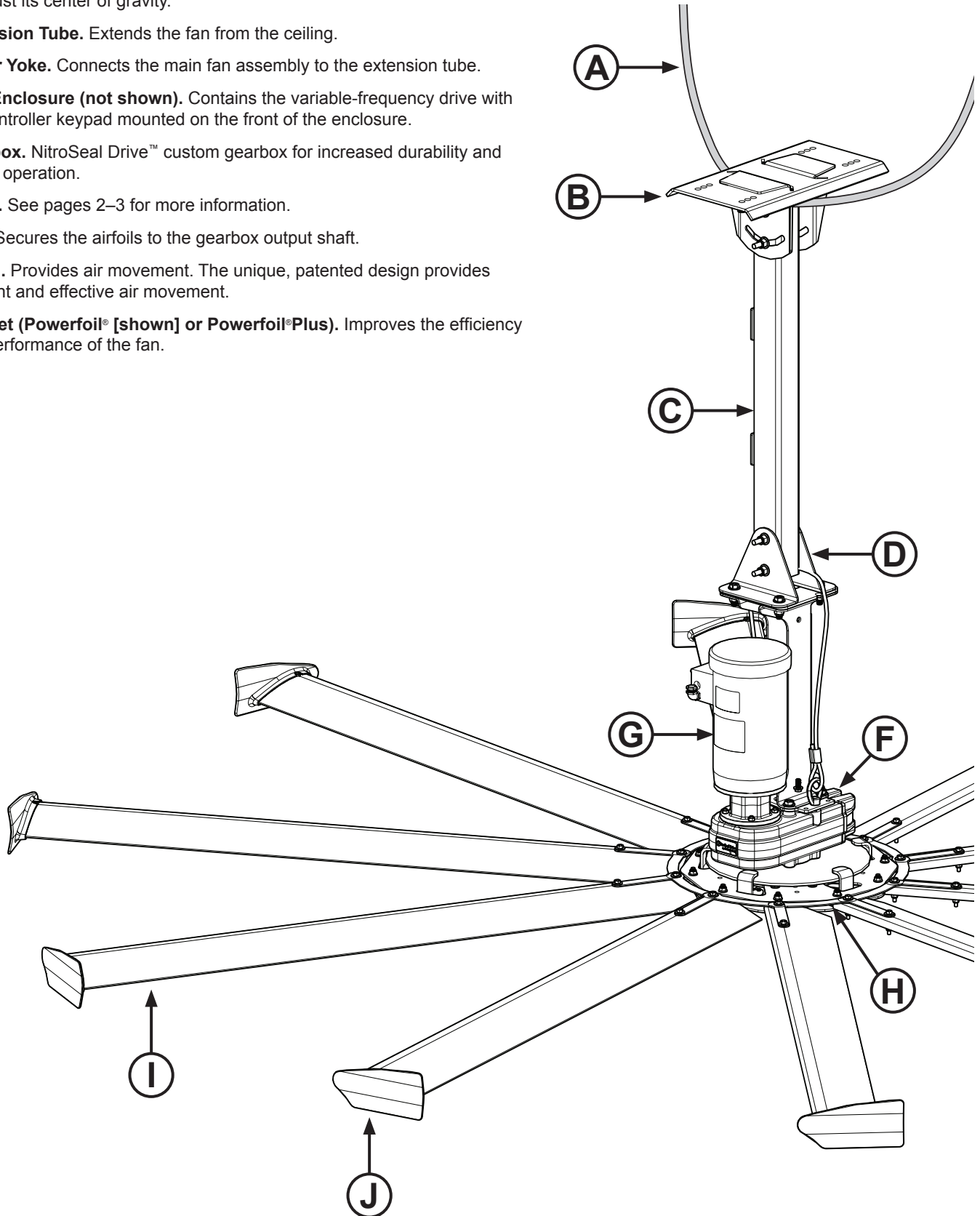

## 8

## Pre-Installation (cont.)

## Controller diagram

*Note: The illustration below does not show wiring.*

- A. Controller Keypad.** Controls fan operation.
- B. Disconnect.** Emergency disconnect for the fan controller. The switch must be used to disconnect power when servicing the VFD or other electrical components.
- C. Variable Frequency Drive (VFD).** The VFD controls AC power to the motor.
- D. Fire Relay.** Shutdown relay for fire-control panel integration.
- E. Fuses.** Protects the system against power surges and over-current.
- F. Category 5 Cable and Connector.** Data cable between the controller keypad and the VFD.

VFD Enclosure (Front View)

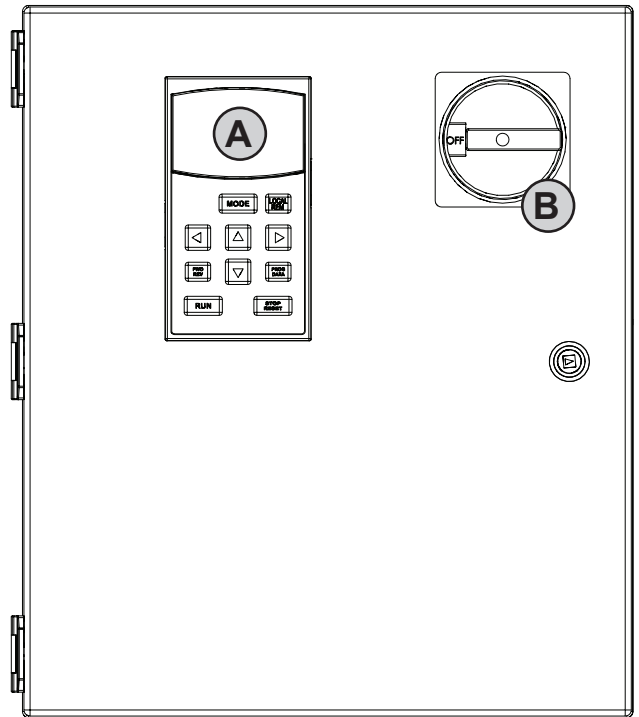

VFD Enclosure (Inner View)

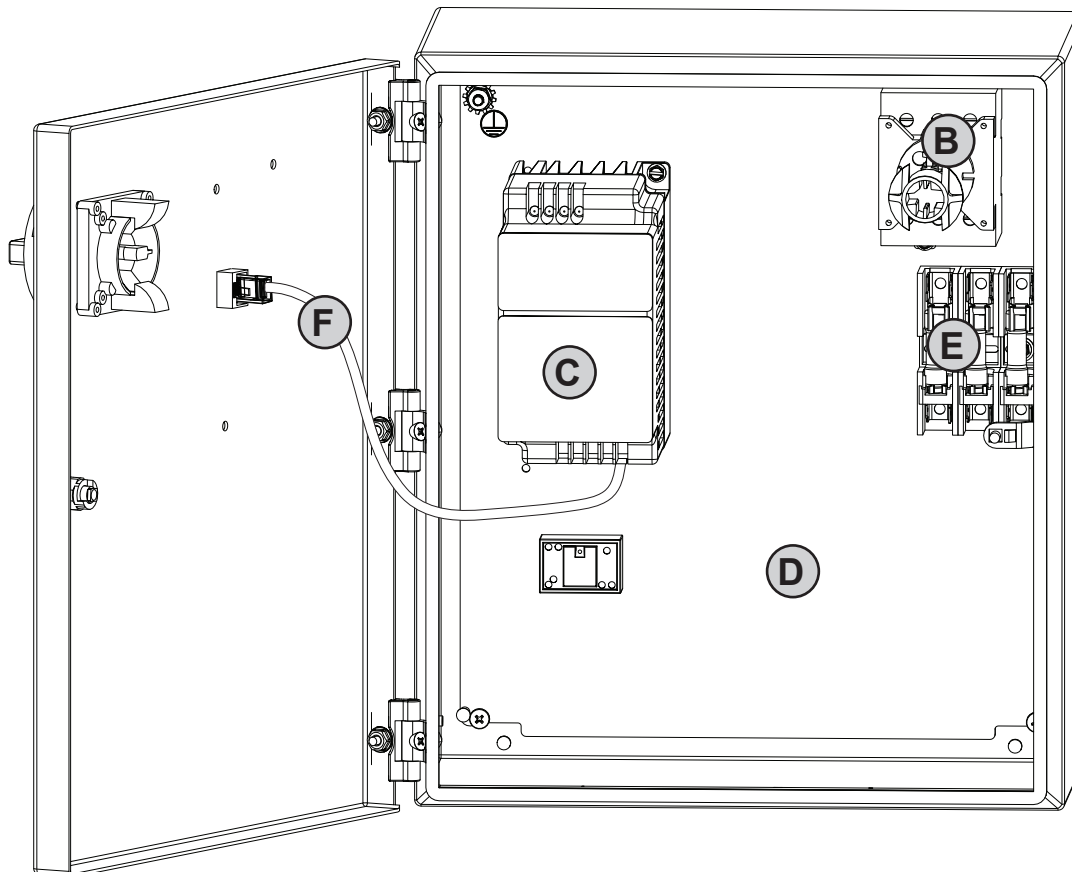



## Preparing the work site

Before beginning installation, review the mechanical and electrical installation guidelines below.

### Mechanical installation

- A 24-ft (7.3-m) Powerfoil®X2.0 fan weighs, at maximum, 500 lbs (227 kg). A suitable means for lifting the weight of the fan, such as a scissor lift, and at least two (2) installation personnel will be required.
- Big Ass Fans can only be mounted to an I-beam or angle irons. If mounting to an I-beam, the I-beam must be part of the existing building structure. Do not mount the fan to a single purlin, truss, or bar joist. Consult a structural engineer for installation methods not covered in the guide.

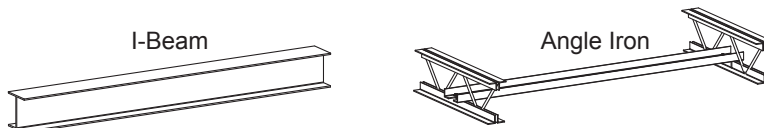

- The mounting structure must be able to withstand the torque forces generated by the fan. A 24-ft fan generates nearly 300 ft·lb (406.7 N·m) of torque during operation.
- Fans mounted on fabricated I-beams, which are common in steel buildings, could cause the beam to flex and the fan to move significantly during operation. If this flexing causes a clearance problem, we suggest installing the I-Beam Stabilizer kit.
- If the fan's extension tube is 4 ft (1.2 m) or longer or if the mounting structure requires it, the fan's lateral movement must be secured using guy wires. If the fan is close to any building fixtures it is recommended to secure the fan with guy wires as a safety measure.
- Adhere to the safety requirements in the table below when selecting where to mount the fan.

Safety requirement	Minimum distances
Clearance	≥2 ft from all fan parts. The fan installation area must be free of obstructions such as lights, cables, sprinklers, or other building structure. See the tables on pp. 2–3 for recommended minimum ceiling clearances.
Airfoil height	≥10 ft above the floor
HVAC equipment	≥1x fan diameter if above diffuser. ≥2x fan diameter if below diffuser. Refer to the illustration below.
Fan spacing	2.5x fan diameter, center-to-center
Radiant/IR heaters	See the manufacturer's requirements for the minimum clearance to combustibles.

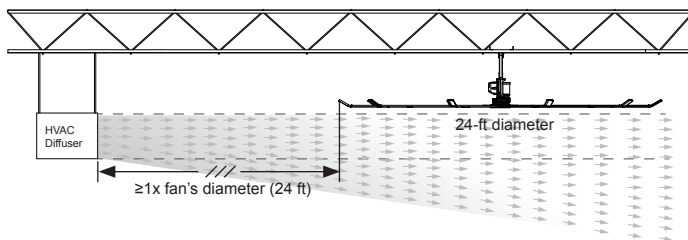

The fan is located at or above the HVAC discharge or intake.

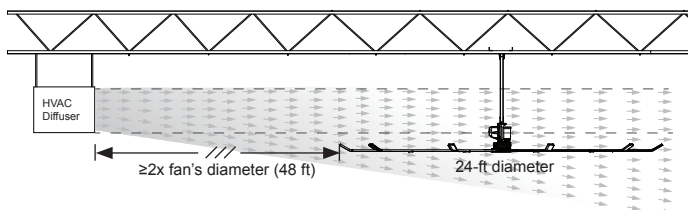

The fan is located below the HVAC discharge or intake.

### Electrical installation

- To reduce the risk of electric shock, wiring should be performed by a qualified electrician! Incorrect assembly can cause electric shock or damage the motor and the controller!
- The installation of a Big Ass Fan must be in accordance with the National Electrical Code (NEC), ANSI/NFPA 70-2011, and all local codes.
- AC supply feeds for one fan controller may share the same conduit with AC supply feeds for one or more controllers.
- All unused conductors that share a conduit with the AC supply feeds must be grounded on both ends.
- If required, a local disconnect should be installed per NEC and all local codes.
- Refer to specifications on pages 2–3 for appropriate circuit requirements.
- Each fan requires dedicated branch circuit protection.
- To avoid damage to the VFD and fan controller, test the VFD and fan controller with a test cable before wiring the CAT 5 cable!

## 10

## Pre-Installation (cont.)

## Understanding airflow patterns

**Airflow in an open area**

The airflow moves from the fan toward the floor. Once airflow hits the floor, it moves outward in all directions. The deflection of air off the floor is called a "floor jet."

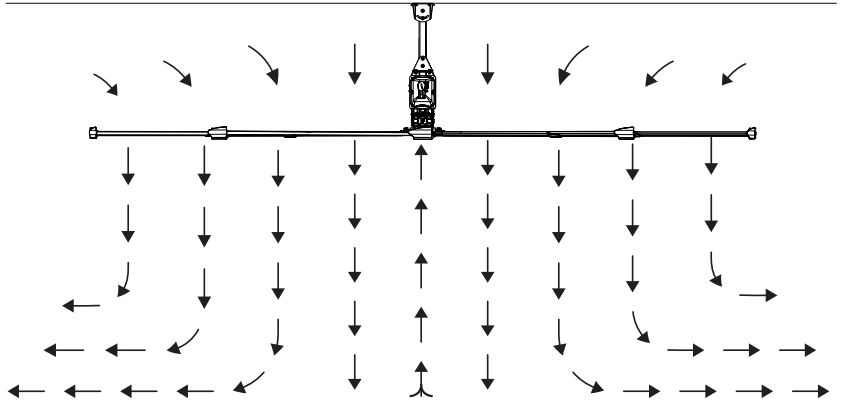
**Airflow in an enclosed area**

The floor jet radiates outward until it reaches the walls, which deflect the jet upward. After it hits the ceiling, the upward flow is directed inward to the low pressure area above the fan where it is then pulled down toward the floor. This creates a convection-like air current that gathers momentum. Once this current is established, the fan begins to move air outside of the current, escalating its cooling effects.

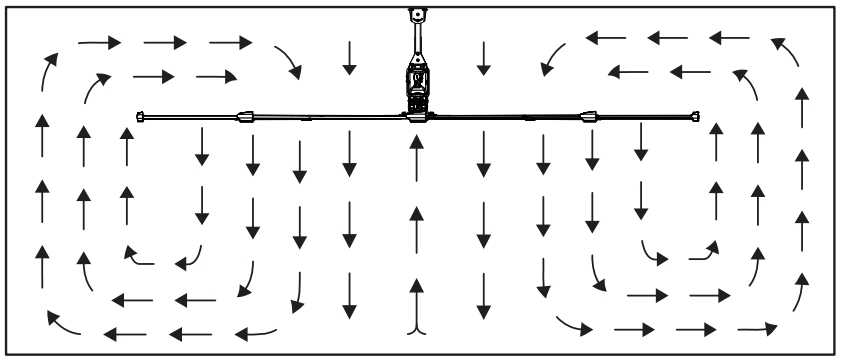
**Airflow with multiple fans**

Where there are multiple fans appropriately spaced, the expanding jets of adjacent fans meet to create a pressure zone. The pressure zone acts like a wall, causing each fan to behave like a single enclosed fan. Typically, a single fan's performance will increase when working in conjunction with other fans.

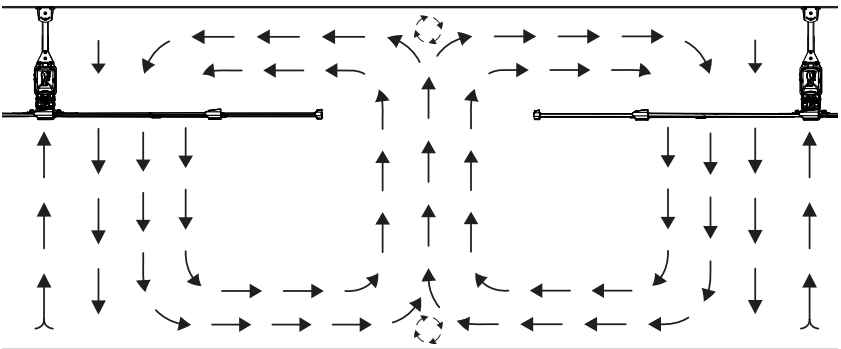
**Airflow with streamlined obstruction**

Obstructions on the floor tend to block the horizontally moving air. Thin or streamlined obstructions do not block much airflow, regardless of size. The air tends to flow smoothly around these obstructions, losing little momentum, and leaving only a small stagnant area behind the obstruction.

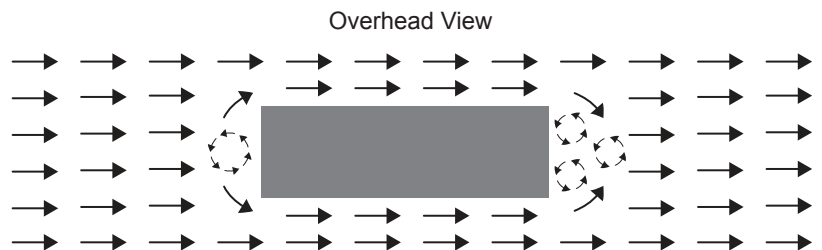
**Airflow with wide, blunt obstruction**

A wide, blunt, or flat-faced obstruction forces airflow to change direction, turning it upward and outward. There is a stagnant area behind these obstructions that is wider and higher than the obstructions themselves.

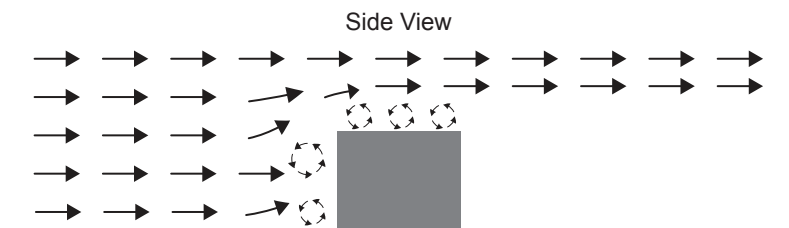

## Powerfoil® X2.0Plus

The PowerfoilPlus winglet creates a jet of air that flows outward at a 45° angle, passing over floor obstructions and delivering airflow in a much broader pattern. When planning fan placement, consider the Powerfoil X2.0Plus fan's larger coverage area. *Note: PowerfoilPlus winglets are optional and may not be included in your fan order.*

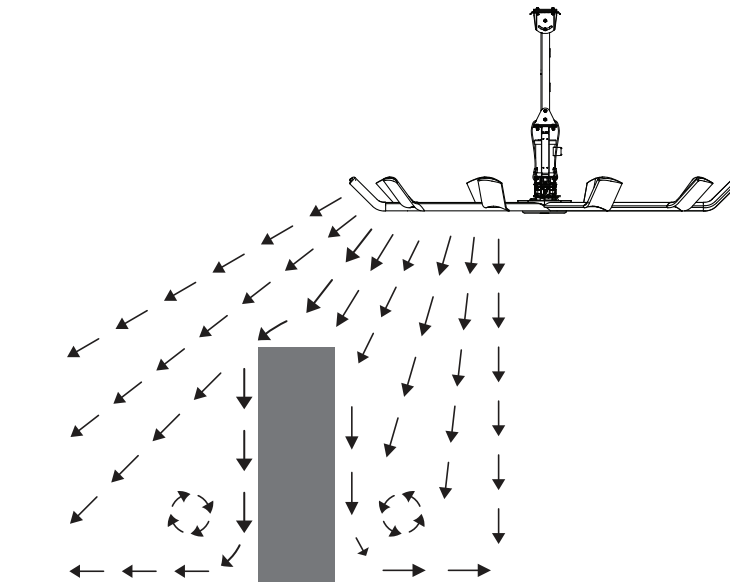

## Tips

Below are some techniques that can make a dramatic difference in congested areas of your facility. Treat air like water, and scoop, direct, and channel it to where it is needed most. *Note: Powerfoil X2.0Plus fans deliver air from a much higher angle, resolving many of the issues outlined below.*

- Make sure people are not hidden behind structures that would block airflow. This may seem obvious, but work areas are routinely blocked by shelving, crates, and machinery.
- Position large obstructions so that their smallest profiles are perpendicular to the direction of air movement. For example, a sheet metal press brake might have five times the frontal area if it is facing the airflow rather than if it is turned sideways.
- Wherever possible, position welding curtains, partitions, sheet materials, etc., to scoop air into the work area rather than deflect it.
- Take advantage of the air moving near the floor by creating ground level openings in your work area. It is better to have a work area blocked by materials stacked to the ceiling with an opening below than to have low stacks 3 ft (0.9 m) to 6 ft (1.8 m) high sitting on the floor.

## 12

## Mounting Structure: I-Beam

**Big Ass Fans can only be hung from an I-beam or bar joists. See the following page for bar joist mounting instructions. Consult a structural engineer for installation methods not covered in this manual.**

- ⚠ WARNING:** The fan should not be installed unless the structure on which the fan is to be mounted is of sound construction, undamaged, and capable of supporting the loads of the fan and its method of mounting. A structural engineer should verify that the structure is adequate prior to fan installation. Verifying the stability of the mounting structure is the sole responsibility of the customer and/or end user, and Big Ass Fans hereby expressly disclaims any liability arising therefrom, or arising from the use of any materials or hardware other than those supplied by Big Ass Fans or otherwise specified in these installation instructions.
- ⚠ CAUTION:** It is not recommended to mount a Big Ass Fan to a fabricated I-beam. The I-beam on which the fan will mount must be part of the existing building structure. Do not direct mount the fan to an I-beam.
- ⚠ CAUTION:** Install the spacers only if the thickness of the I-beam flange exceeds 3/8" (1 cm). The mounting holes on the spacer are closer to one edge than the other. Make sure this edge of the spacer is facing the I-beam.
- ⚠** Before beginning installation, confirm that you have the appropriate mount for your roof pitch.

### Attach upper yoke (to I-beam)

Measure the flange width of the I-beam from which the fan will be hung. Select the upper yoke mounting holes that match the flange width of the I-beam.

Secure the upper yoke to the I-beam with the Upper Yoke Hardware as shown. Tighten the bolts to **40 ft·lb (54.2 N·m)** using a torque wrench and 3/4" socket.

Proceed to "Hanging the Fan" (p. 19).

#### Upper Yoke Hardware (BAF-Supplied):

- (4) 1/2-13 x 2" GR 8 Bolt
- (8) 1/2" Flat Washer
- (4) 1/2-13 Nylock Nut
- (2) Beam Clip
- (2) Spacer

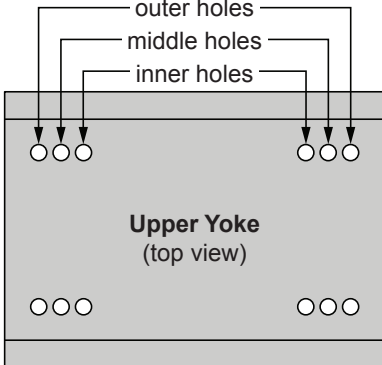
Small Upper Yoke 13-3/4" (349 mm) x 10" (258 mm)		Upper Yoke (top view)	Large Upper Yoke 18-1/2" (470 mm) x 10" (258 mm)	
I-beam flange width	Upper yoke mounting holes		I-beam flange width	Upper yoke mounting holes
5" (127 mm) to 6-5/8" (168 mm)	Inner holes		9-7/8" (250 mm) to 11-3/8" (289 mm)	Inner holes
>6-5/8" (168 mm) to 8-1/4" (210 mm)	Middle holes		>11-3/8" (289 mm) to 13" (330 mm)	Middle holes
>8-1/4" (210 mm) to 9-7/8" (250 mm)	Outer holes		>13" (330 mm) to 14-5/8" (371 mm)	Outer holes

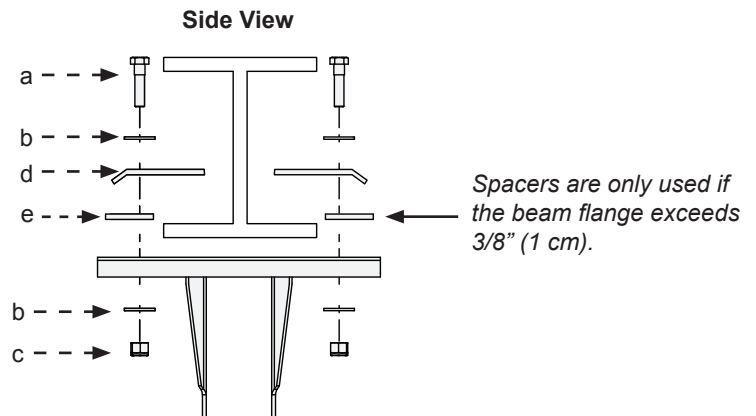
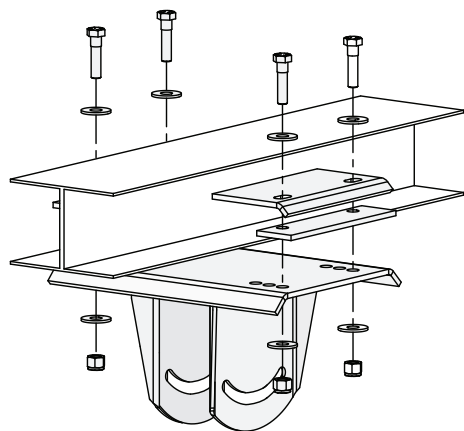

Note: Ensure the spacers are oriented as shown above.

# Mounting Structure: Bar Joists

13

**Big Ass Fans can only be hung from an I-beam or bar joists. See the previous page for I-beam mounting instructions. Consult a structural engineer for installation methods not covered in this manual.**

- ⚠ **WARNING:** The fan should not be installed unless the structure on which the fan is to be mounted is of sound construction, undamaged, and capable of supporting the loads of the fan and its method of mounting. A structural engineer should verify that the structure is adequate prior to fan installation. Verifying the stability of the mounting structure is the sole responsibility of the customer and/or end user, and Big Ass Fans hereby expressly disclaims any liability arising therefrom, or arising from the use of any materials or hardware other than those supplied by Big Ass Fans or otherwise specified in these installation instructions.
- ⚠ **WARNING:** Never use beam clips when mounting the fan to angle irons! Beam clips are only intended for I-beam installations.
- ⚠ **CAUTION:** Do not install the fan from a single purlin, truss, or bar joist.
- ⚠ **CAUTION:** Unsupported angle iron spans should not exceed 12 ft (3.7 m).
- ⚠ **CAUTION:** The angle irons must be fastened to the roof structure at each end.

## 1. Select proper angle irons

Using the table and diagrams below, select the proper angle irons for fan installation.

*Note: Angle irons and angle iron hardware are not included with the fan.*

Angle iron span (between mounting points)	Minimum angle iron dimensions (W x H x T)	Number of angle irons needed
6 ft (1.8 m) or less	2.5" (6.4 cm) x 2.5" (6.4 cm) x 0.25" (0.6 cm)	2
6 ft (1.8 m) to 8 ft (2.4 m)	3" (7.6 cm) x 3" (7.6 cm) x 0.25" (0.6 cm)	2
8 ft (2.4 m) to 12 ft (3.7 m)	3" (7.6 cm) x 3" (7.6 cm) x 0.25" (0.6 cm)	4*

\*Two pairs of angle irons. Pairs should be placed back to back and fastened in center (see step 3).

Angle Iron Side View  
(see table for dimensions)

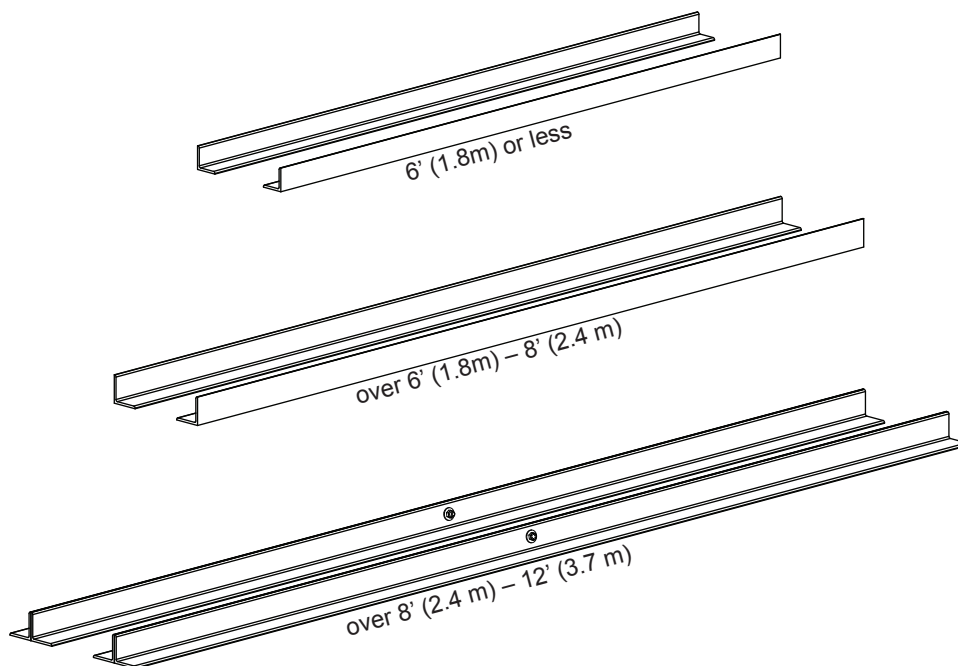
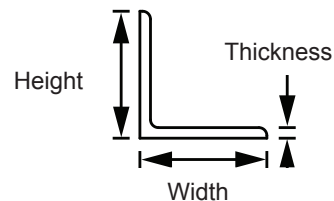

## 14

## Mounting Structure: Bar Joists (cont.)

## 2. Pre-drill angle irons

**Before drilling the angle irons, confirm that you have the appropriate mount to accommodate the roof pitch of your mounting structure.**

Drill two  $\text{Ø}9/16''$  (1.4 cm) holes exactly  $5\text{-}3/8''$  (13.7 cm) apart in the centers of two angle irons.

Measure the distance between the mounting points of the roof structure that the angle irons will span. Measure the same distance on the angle irons and drill  $\text{Ø}9/16''$  (1.4 cm) holes through each end of the angle irons. Drill holes in two angle irons if the span is 8 ft (2.4 m) or less. Drill holes in 4 angle irons if span is greater than 8 ft (2.4 m).

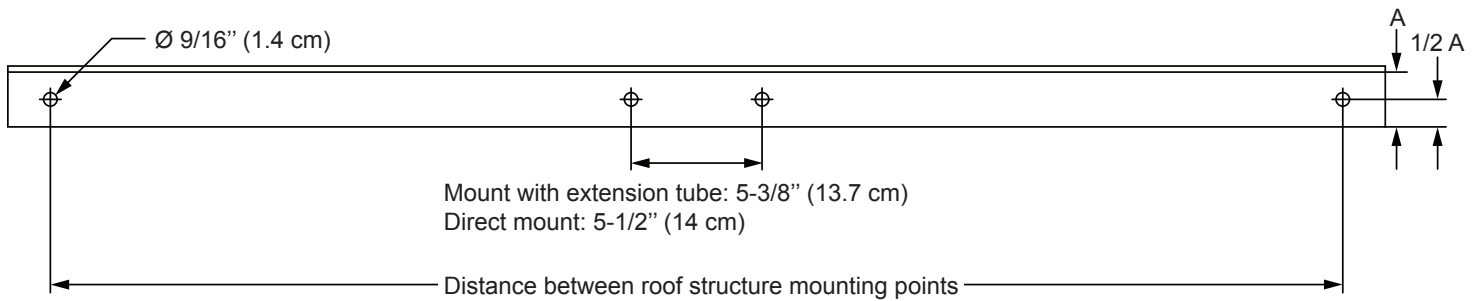

## 3. Secure angle irons (span longer than 8 ft)

**If the angle iron span is 8 ft (2.4 m) or less, skip step 3 and proceed to step 4a.**

If the angle iron span is longer than 8 ft (2.4 m), it is necessary to use double angle irons.

Locate the center of the angle iron length. Drill  $\text{Ø}9/16''$  (1.4 cm) hole through the center of the vertical wall of the angle iron. Drill a total of four angle irons.

Place two drilled angle irons back to back. Fasten the angle irons together with customer-supplied  $\text{Ø}1/2\text{-}13$  stainless steel hardware and tighten the bolts to **40 ft·lb (54.2 N·m)** using a torque wrench and  $3/4''$  socket.

Repeat this step for the remaining two angle irons.

**Proceed to step 4b.**

**Angle Iron Hardware (Customer-Supplied):**

- a. (2)  $1/2\text{-}13$  Bolt
- b. (4)  $1/2''$  Washer
- c. (2)  $1/2''$  Nut

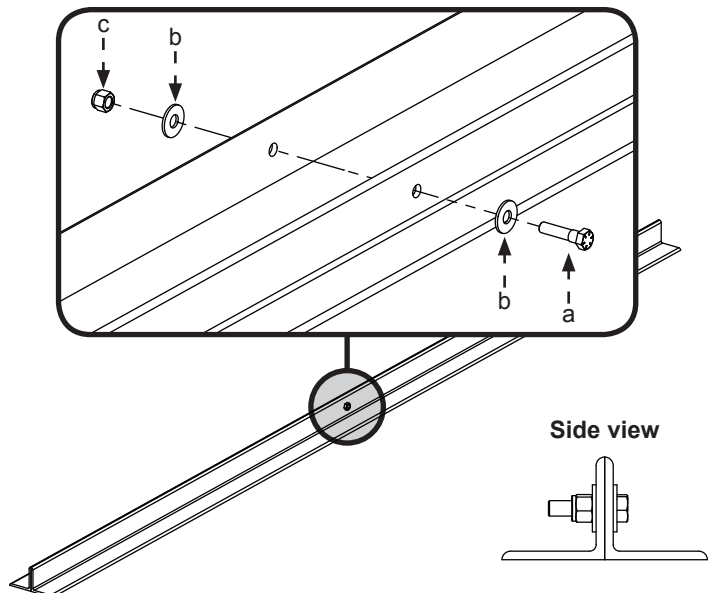

#### 4a. Fasten single angle irons to roof structure

If the angle iron span is greater than 8 ft (2.4 m) and requires double angle irons, proceed to step 4b.

Fasten the angle irons to the roof structure mounting points at each end with customer-supplied hardware as shown. *Do not tighten the hardware until the upper yoke has been mounted to the angle irons (step 5).* Big Ass Fans recommends orienting the angle irons so that the horizontal legs are facing each other (vertical legs are on the outside).

Proceed to step 5.

##### Grade 8 Hardware (Customer-Supplied):

- (4) 1/2-13 Bolt
- (8) 1/2" Washer
- (4) 3" Square Washer (BAF-Supplied; see diagram)
- (4) 1/2" Nylock Nut

##### Square Washer

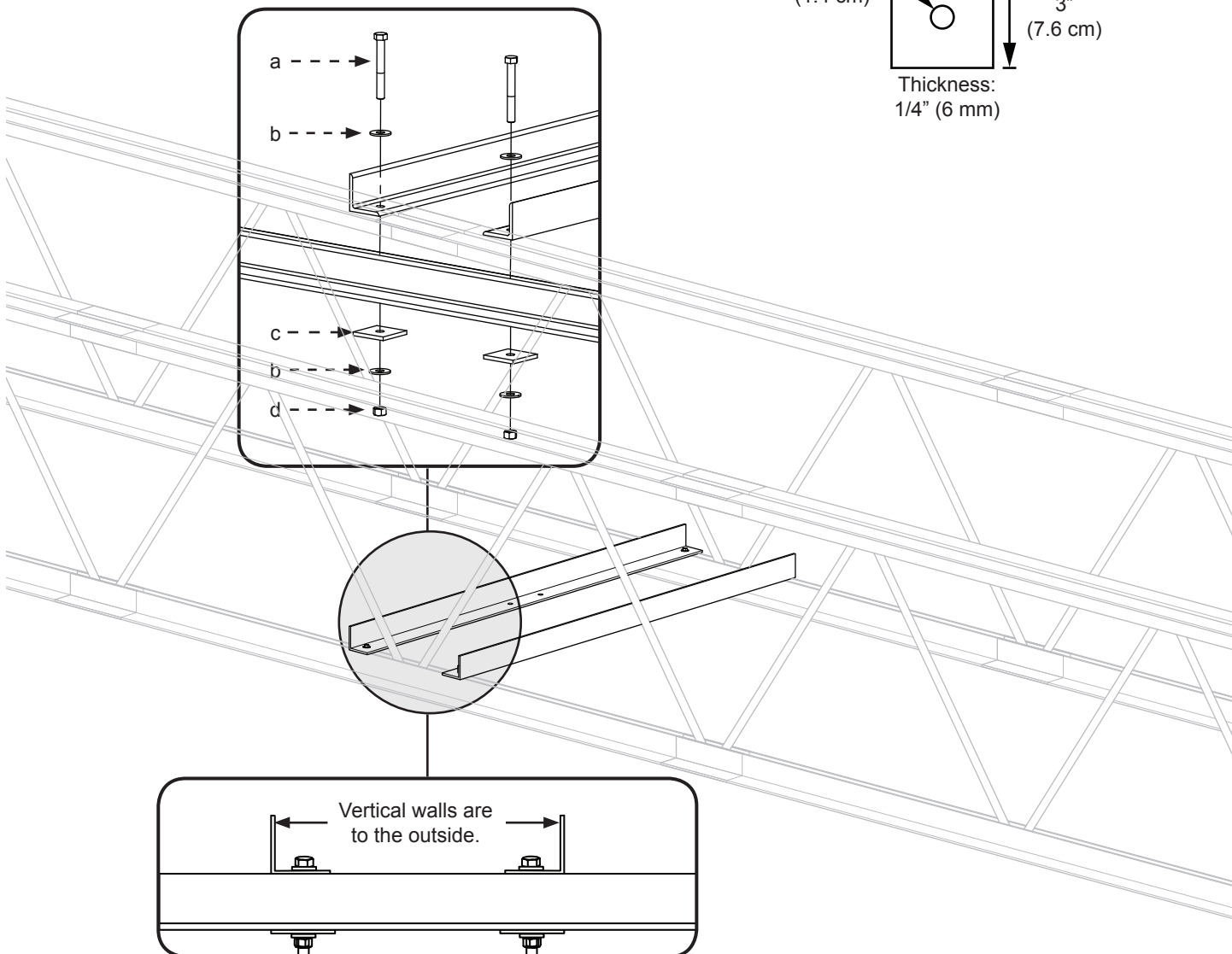
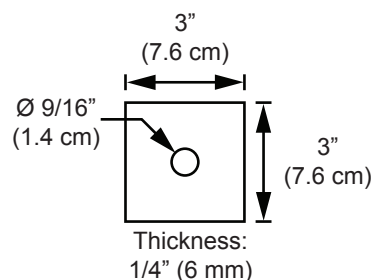

Note: Ensure the angle irons are oriented as shown.

## 16

## Mounting Structure: Bar Joists (cont.)

## 4b. Fasten double angle irons to roof structure

Fasten the angle irons to the roof structure mounting points at each end with customer-supplied hardware as shown. The angle irons with fan mounting holes should be positioned on the inside, facing each other. *Do not tighten the hardware until the upper yoke has been mounted to the angle irons.*

**Angle Iron Hardware (Customer-Supplied):**

- a. (8) 1/2-13 Bolt
- b. (16) 1/2" Washer
- c. (8) 3" Square Washer (BAF-Supplied; see diagram)
- d. (8) 1/2" Nylock Nut

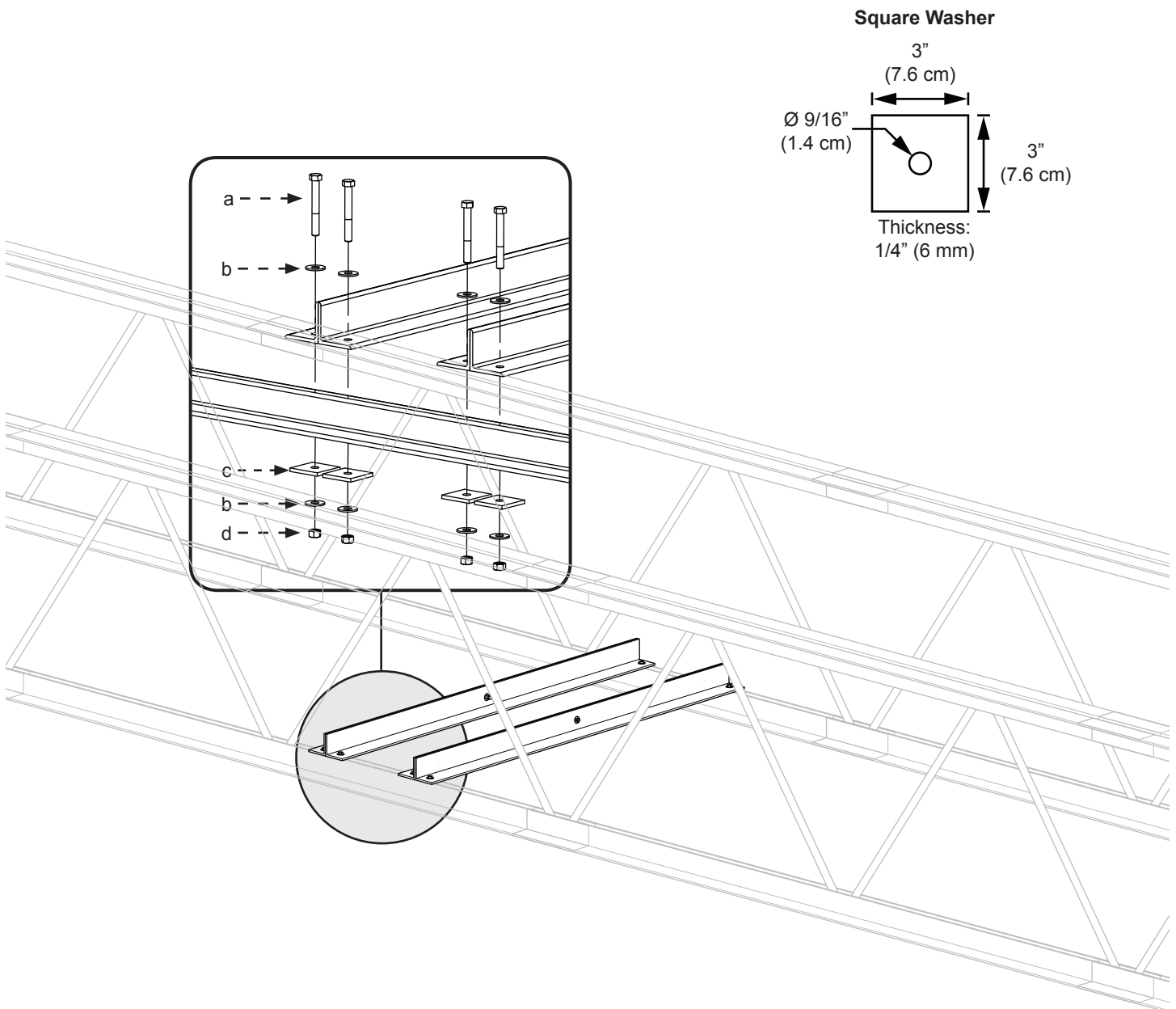



### 5a. Attach upper yoke (to angle irons)

If the fan will be directly mounted to the angle irons, skip this step and proceed to step 5b.

Before drilling the angle irons, confirm that you have the appropriate mount to accommodate the roof pitch of your mounting structure.

Secure the upper yoke directly to the angle irons with the Upper Yoke Hardware as shown. The angle irons should be aligned with the outermost holes of the upper yoke. Consult the diagrams below for distances between the angle irons.

Tighten the bolts to **40 ft·lb (54.2 N·m)** using a torque wrench and 3/4" socket. After attaching the upper yoke to the angle irons, tighten all the bolts securing the angle irons to the roof structure to **40 ft·lb (54.2 N·m)**.

Proceed to "Hanging the Fan" (p. 19).

#### Upper Yoke Hardware (BAF-Supplied):

- (4) 1/2-13 x 2" GR 8 Bolt
- (8) 1/2" Flat Washer
- (4) 1/2-13 Nylock Nut

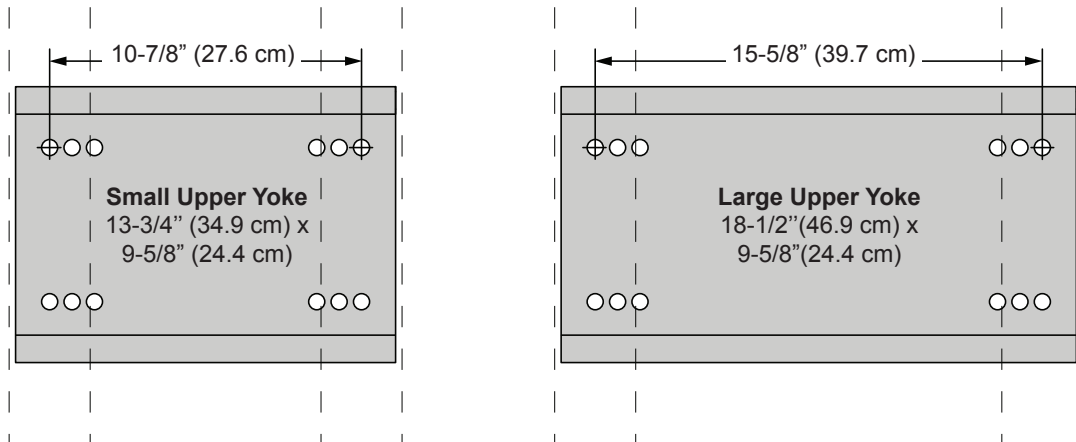

Note: Dashed lines represent angle irons in the above illustrations.

The angle irons should be aligned with the outermost holes on the upper yoke. Do not use beam clips on angle irons!

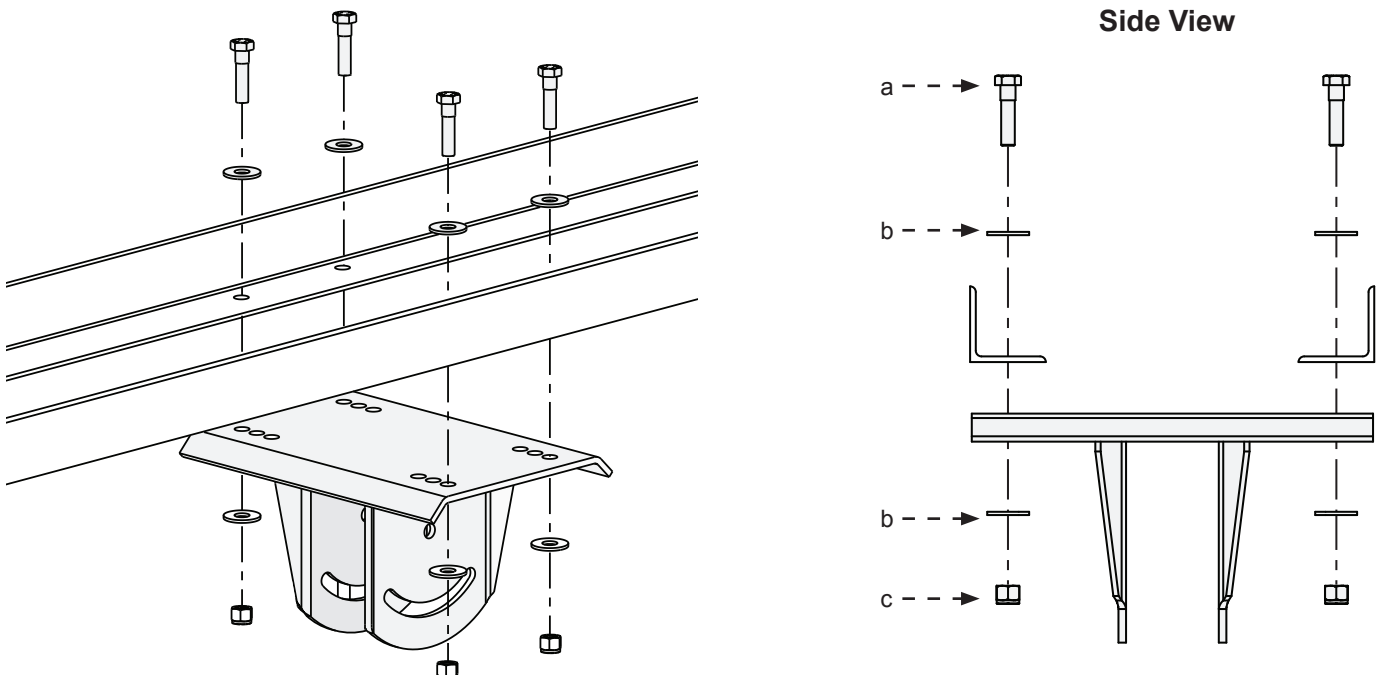

**5b. Attach main fan unit (to angle irons)**

**⚠ CAUTION:** The main fan unit is heavy. Use caution when raising it.

Attach the main fan unit directly to the angle irons with the Motor Hub Hardware as shown. Consult the diagram below for distances between the angle irons. *Note: The fan can only be directly mounted to angle irons. Do not directly mount the fan to an I-beam.*

Tighten the bolts to **40 ft·lb (54.2 N·m)** using a torque wrench and 3/4" socket. After attaching the main fan unit to the angle irons, tighten all the bolts securing the angle irons to the roof structure to **40 ft·lb (54.2 N·m)** using a torque wrench and 3/4" socket.

Proceed to "Secure Upper Safety Cable" (p. 19).

**Main Fan Unit Hardware (BAF-Supplied):**

- a. (4) 1/2-13 x 1 3/4" GR 8 Bolt
- b. (8) 1/2" Flat Washer
- c. (4) 1/2-13 Nylock Nut

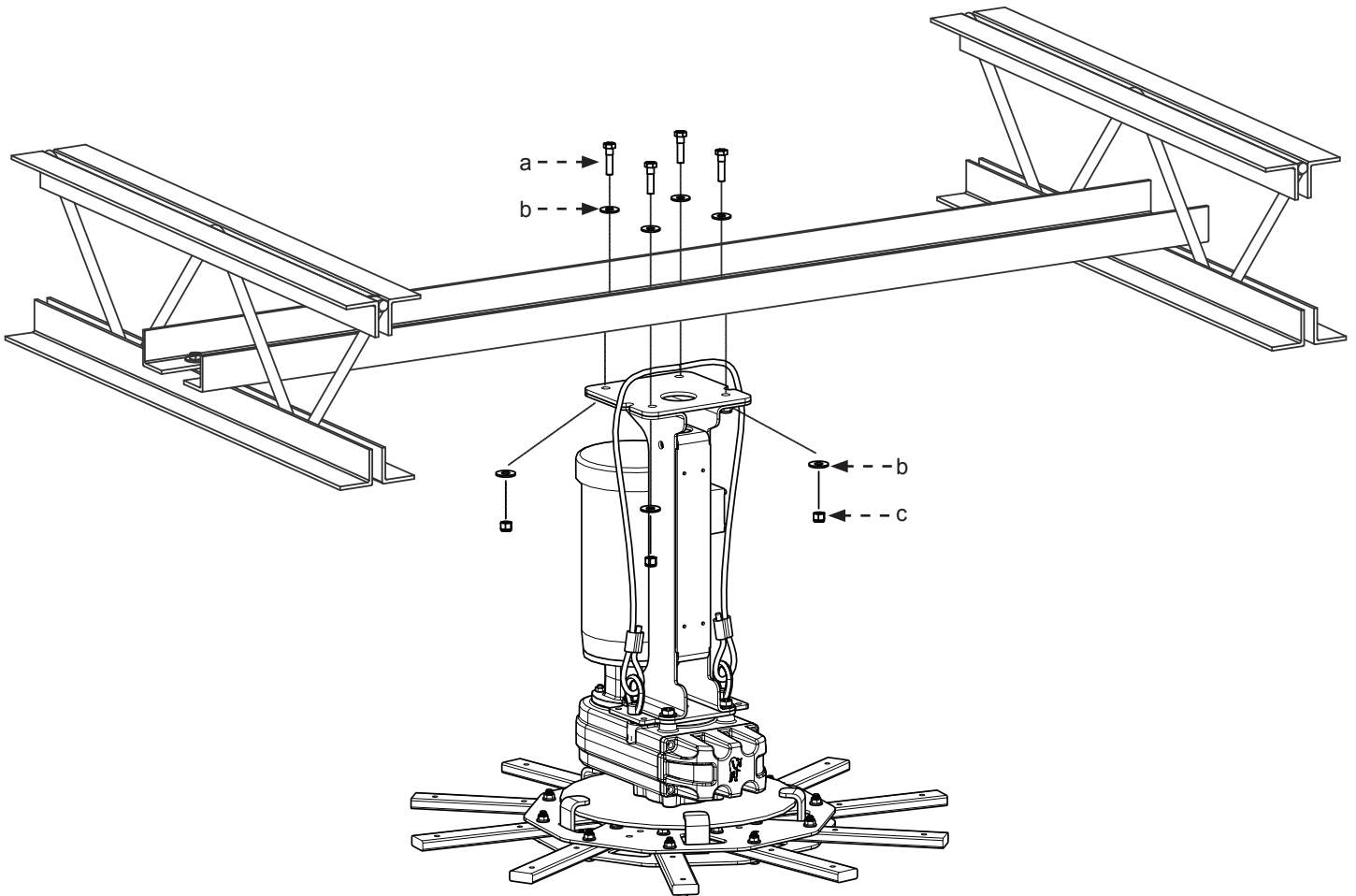
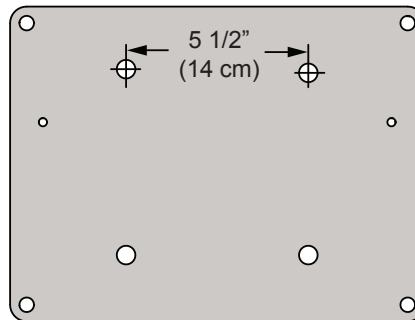

# Hanging the Fan

19

## 1. Attach extension tube (to upper yoke)

Fasten the extension tube to the upper yoke with the Extension Tube Hardware as shown. *In order to efficiently drain water, the tube must be oriented so that slots on the bars between the extension tube flanges are facing downward.* Refer to the illustration below.

Ensure the extension tube is hanging plumb to the ground, and then tighten the hardware so that it is snug, but not fully tightened.

### Extension Tube Hardware (BAF-Supplied):

- (2) 1/2-13 Nylock Nut
- (4) 1/2" Flat Washer
- (2) 1/2-13 x 4-1/2" GR 8 Bolt

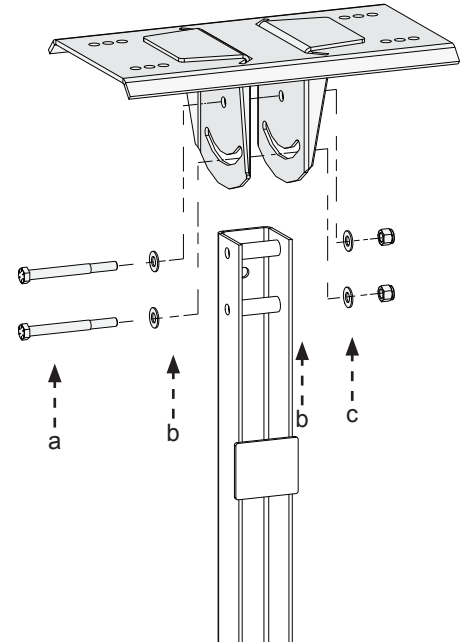
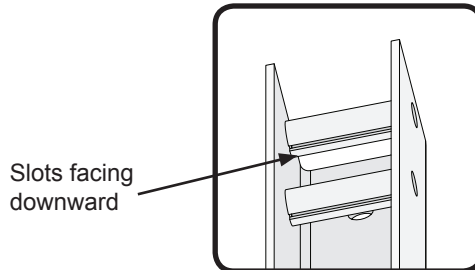

## 2. Secure upper safety cable

**The safety cable is a crucial part of the fan and must be installed correctly. If you have questions or require assistance, call Customer Service for assistance.**

Wrap the safety cable around the mounting structure and secure the looped ends with the shackle as shown. The cable must be drawn tightly around the I-beam or angle iron, leaving as little slack as possible. The shackle should be on the topside of the I-beam or angle iron if possible. Securely tighten the shackle.

I-Beam Mount

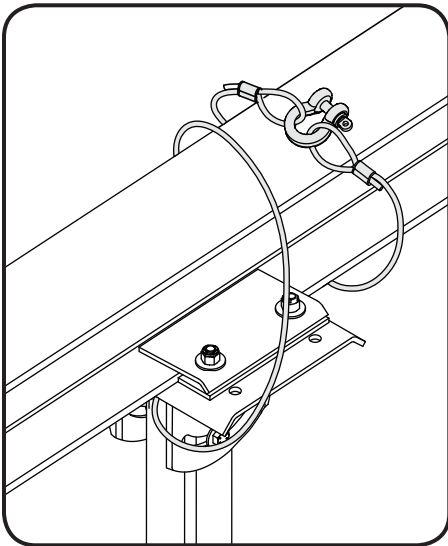

Shackle

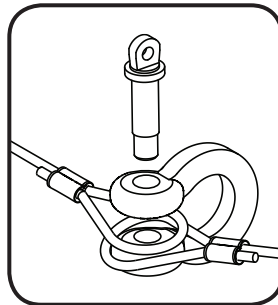

Angle Iron Mount

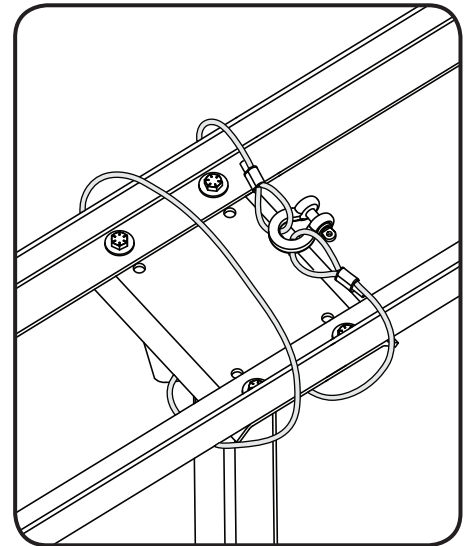

Direct Mount

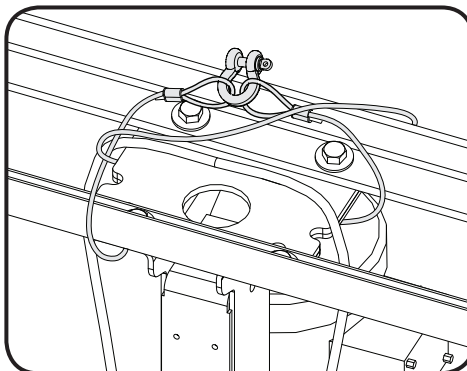

### 3. Attach lower yoke (to extension tube)

Attach the lower yoke to the bottom of the extension tube with the Lower Yoke Hardware as shown.

Tighten the hardware so that it is snug, but not fully tightened.

#### Lower Yoke Hardware (BAF-Supplied):

- a. (2) 1/2-13 x 4-1/2" GR 8 Bolt
- b. (4) 1/2" Flat Washer
- c. (2) 1/2-13 Nylock Nut

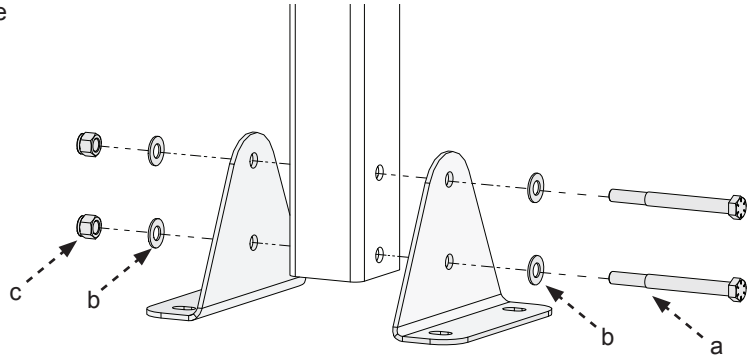

### 4. Attach main fan unit (to lower yoke)

- ⚠ **CAUTION:** Do not remove main fan unit from its protective packaging prior to hanging it!
- ⚠ **CAUTION:** To prevent damage, avoid contact with the bottom of the main fan unit and hub!
- ⚠ **CAUTION:** The main fan unit is heavy. Use caution when raising it.

Attach the main fan unit to the lower yoke with the Main Fan Unit Hardware as shown. *Do not rest the main fan unit on the ground!* Make sure the lower cable is positioned between the lower yoke brackets as shown on the right.

Tighten the bolts to **40 ft·lb (54.2 N·m)** using a torque wrench and 3/4" socket. *Do not discard the main fan unit packaging. It should be used if the fan is ever moved or relocated.*

#### Main Fan Unit Hardware (BAF-Supplied):

- a. (4) 1/2-13 x 1 3/4" GR 8 Bolt
- b. (8) 1/2" Flat Washer
- c. (4) 1/2-13 Nylock Nut

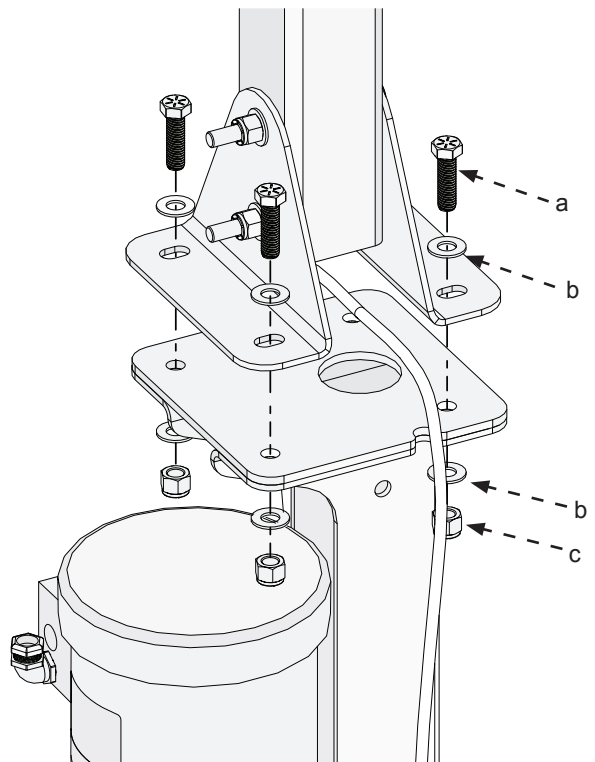

### 5. Confirm orientation

After securing the main fan unit to the lower yoke, allow the fan to hang so that the extension tube is plumb to the ground. When it is properly positioned, fully tighten the mounting hardware (Lower Yoke Hardware and Extension Tube Hardware) to **40 ft·lb (54.2 N·m)**.

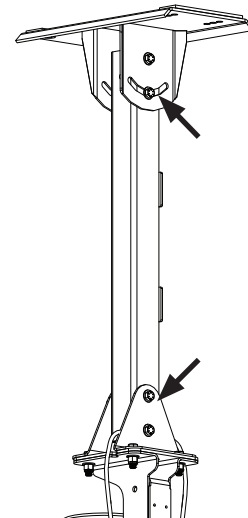

# Installing Guy Wires

Guy wires may not be included in your fan order. They are intended to constrain the fan's lateral movement and are only included with fans that have extension tubes 4 ft (1.2 m) or greater in length. Depending on the conditions at the installation site, guy wires may be needed for fans with shorter tubes to prevent any lateral movement. If guy wires are needed and were not included with your fan order, contact Big Ass Fans Customer Service.

**⚠ WARNING:** Ensure power is disconnected from the fan before installing the guy wires.

## 1. Attach locking carabiners to main fan unit

Attach the (4) locking carabiners to the guy wire clips on the main fan unit as shown. Securely tighten the carabiners.

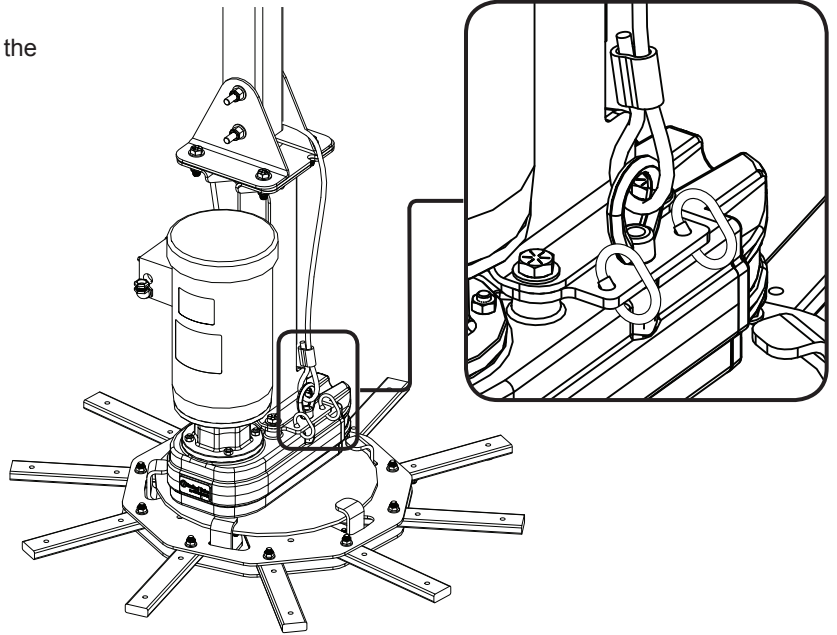

## 2. Attach beam clamp

Attach the beam clamp to the mounting structure. *The guy wire should be approximately 45° from the horizontal plane. Place the beam clamp accordingly. Refer to the illustrations on the following page. Fully tighten the set screw to secure the clamp.*

Fasten the small eyebolt and nut onto the beam clamp. The nut will be on the outside of the beam clamp.

Loop the crimped end of the guy wire into the locking carabiner and secure to the eyebolt as shown. Securely tighten the carabiner.

### Guy Wire Hardware (BAF-Supplied):

- a. 1/4" Beam Clamp
- b. 1/4-20 x 1" Eyebolt
- c. 1/4-20 Hex Nut
- d. Locking Carabiner
- e. Guy Wire

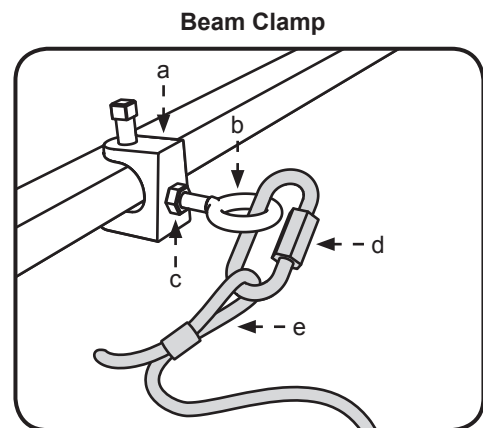

## Installing Guy Wires (cont.)

For best results, the guy wires should be installed at 45° in the X-Y, Y-Z, and X-Z planes as shown below. If the angle deviates by more than 15°, contact Customer Service for assistance.

*Note: I-beams are shown in the illustration below. Your mounting structure may differ.*

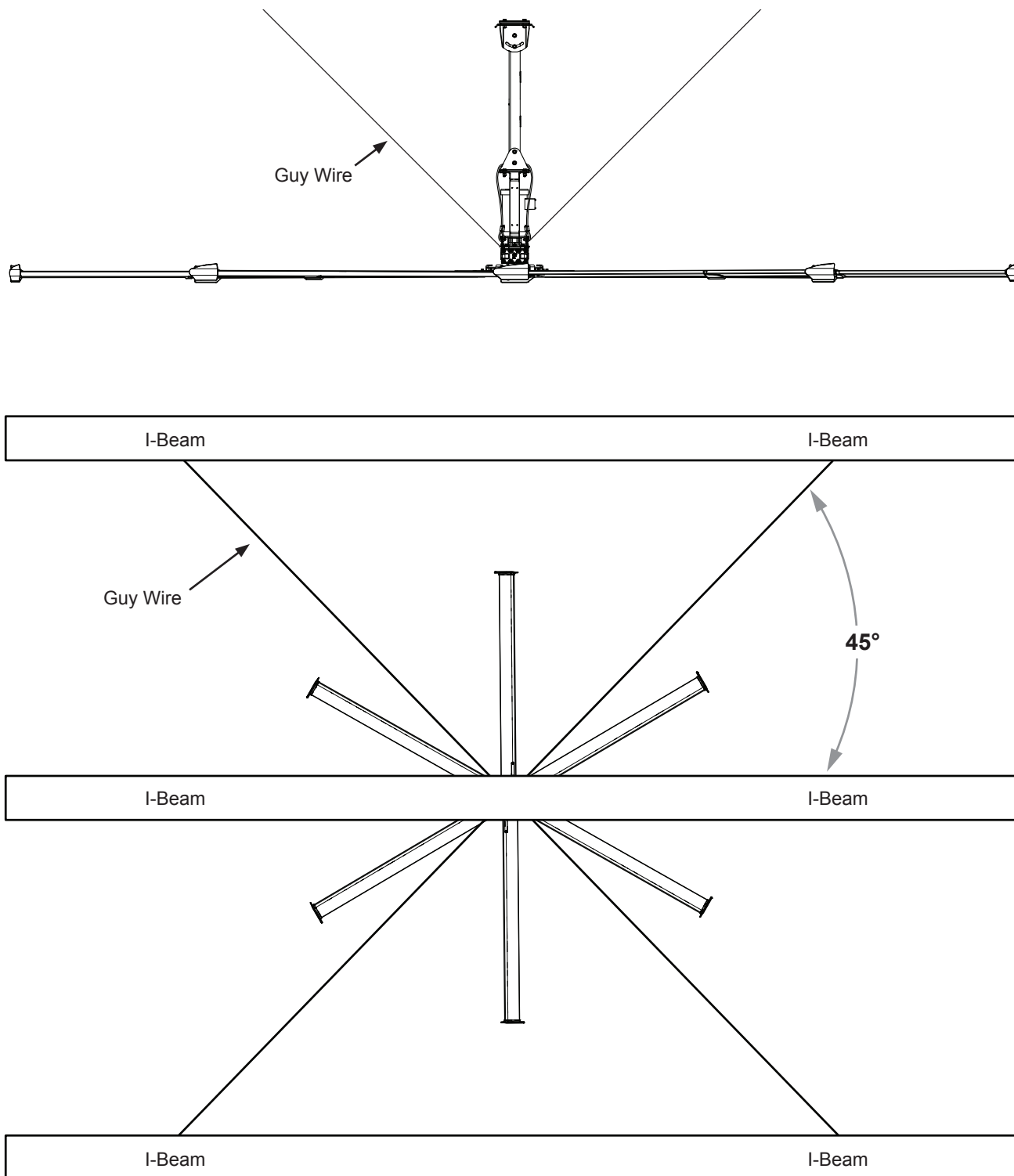

## Installing Guy Wires (cont.)

**3. Route guy wire through Gripple®**

Route the guy wire through the Gripple, the carabiner on the main fan unit, and then back through the Gripple as shown. Do not tighten the Gripple until the remaining guy wires have been installed.

*Note: To back the guy wire out of the Gripple, insert 1/16 (1.5 mm) Allen wrench into the small hole on the Gripple.*

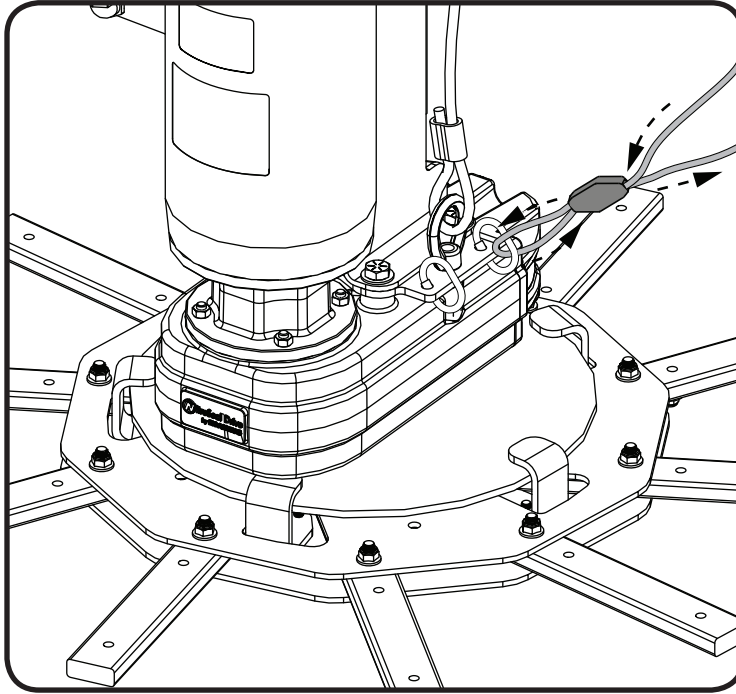
**4. Install remaining guy wires**

**⚠ CAUTION:** Over-tightening the guy wires could throw the fan off balance.

Repeat steps 2–3 to install the three remaining guy wires.

Evenly cinch all four guy wires into place using the Gripples. The guy wires should be taut, evenly spaced around the fan, and away from the path of the airfoils. Maintain a distance of 6"–8" between the Gripple and the carabiner.

Once all of the guy wires are taut, secure their loose ends with the wire rope clips and torque to **4.5 ft·lb (6.1 N·m)**. *Ensure all electrical cords/cables are unobstructed by the guy wire system.*

Wire Rope Clip

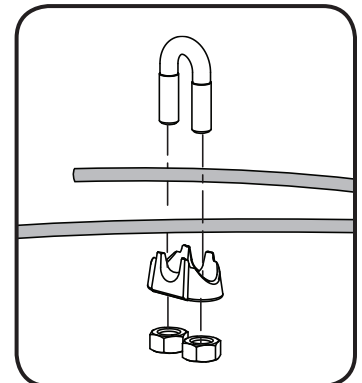

## 24

## Installing Airfoils

Big Ass Fans recommends completing Electrical Installation (p. 26) before installing the airfoils.

**⚠ WARNING:** Disconnect power to the fan before installing the airfoils.

### 1. Attach winglets to airfoils

Attach the winglet to the airfoil using the Winglet Hardware as shown. Both a Phillips head and flat head screwdriver are required to properly secure the fasteners. *Attach winglets to all 10 airfoils before attaching the airfoils to the fan.*

#### Winglet Hardware (BAF-Supplied):

- a. (10) 10-24 x 1/2" Bolt
- b. (10) 10-24 x 3/4" Barrel

#### PowerfoilPlus

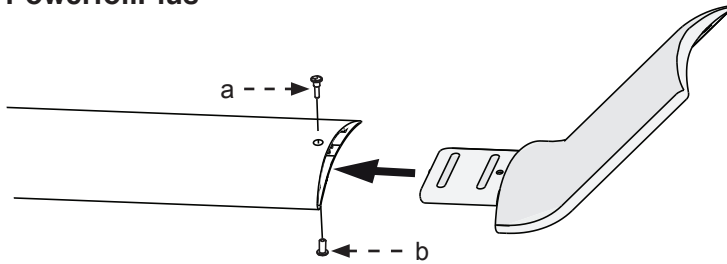

#### Powerfoil

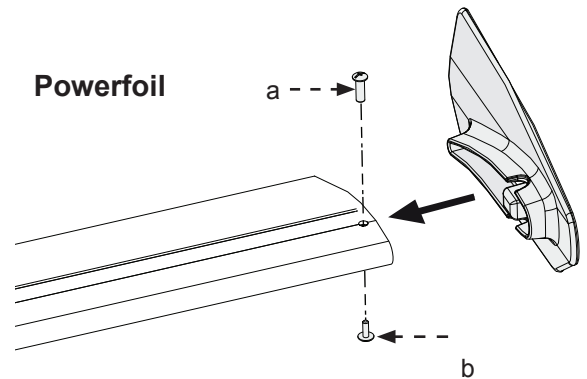

### 2. Position airfoils

Slide the airfoils onto the tabs of the fan hub. *The airfoils must be attached to the fan hub with the curved sides facing downward.*

Do not fasten the airfoils to the hub with hardware at this point. Proceed to step 3.

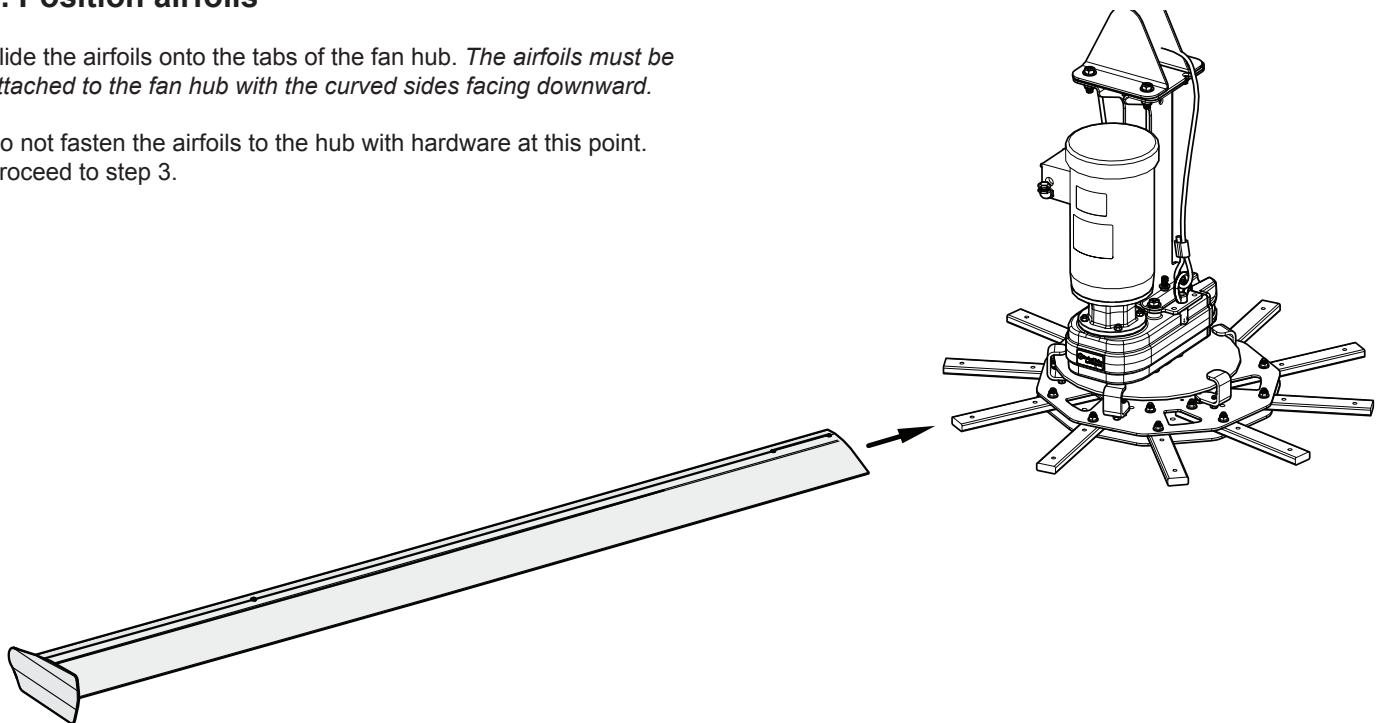



## Installing Airfoils (cont.)

**3. Attach airfoils to hub**

Attach the 10 airfoil retainers with the Airfoil Hardware. Moving clockwise around the fan hub, position the airfoil retainers end over end as shown. Hole A of the retainer should be positioned over top of Hole B. *Do not tighten the bolts until all the airfoil retainers have been attached!*

Tighten the bolts along the outer perimeter to **29 ft·lb (39 N·m)** using a torque wrench and 1/2" socket. After the outer perimeter bolts are torqued, tighten the bolts along the inner perimeter to **29 ft·lb (39 N·m)**.

**Airfoil Hardware (BAF-Supplied):**

- a. (20) 5/16-18 x 2" GR 8 Bolt
- b. (40) 5/16" Flat Washer
- c. (20) 5/16-18 Nylock Nut

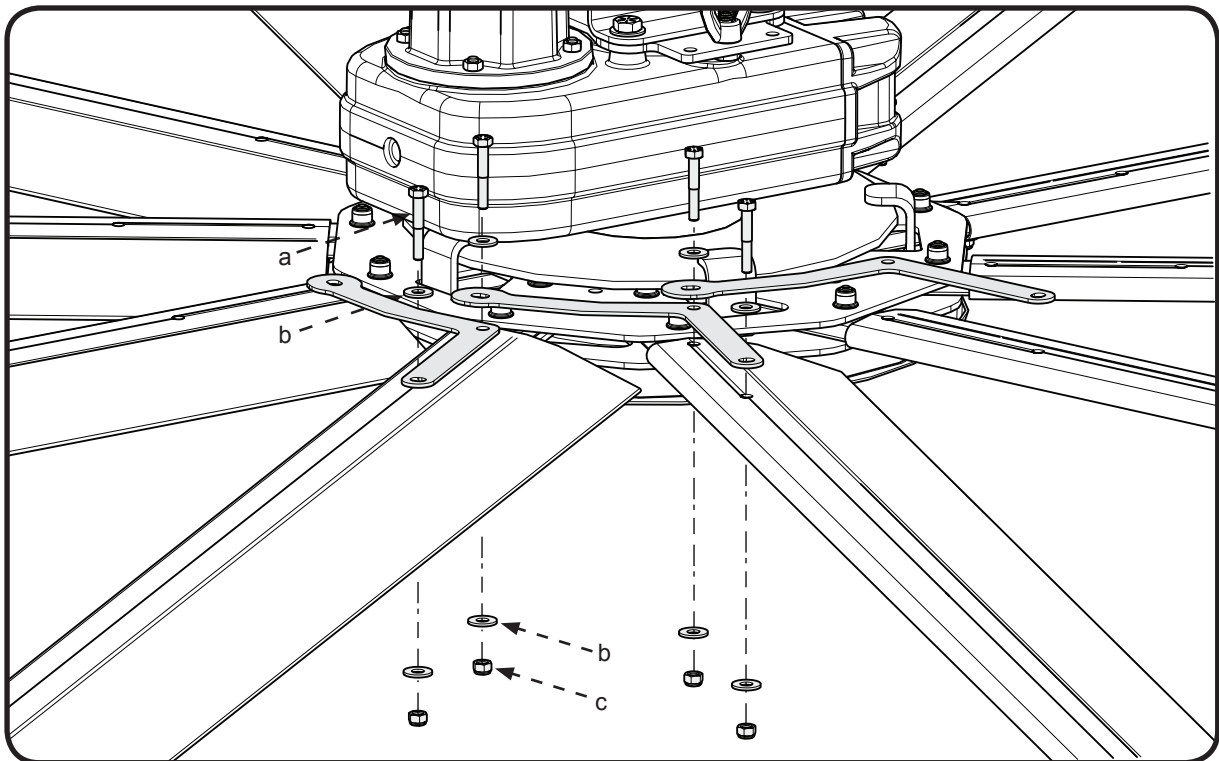
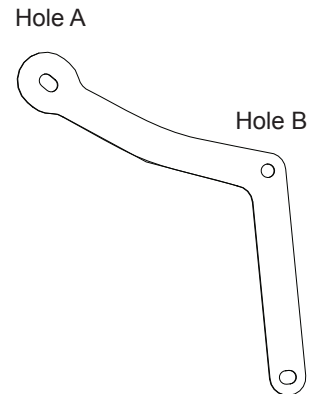
**Airfoil Retainer**

# Electrical Installation



**WARNING:** To reduce the risk of electric shock, wiring should be performed by a qualified electrician! Incorrect assembly can cause electric shock or damage the motor and the controller! Hazard of electrical shock!

**WARNING:** The installation of a Big Ass Fan must be in accordance with the requirements specified in this installation manual and with any additional requirements set forth by the National Electric Code (NEC), ANSI/NFPA 70-2011, and all local codes. Code compliance is ultimately YOUR responsibility!

**WARNING:** The fan controllers contain high voltage capacitors that take time to discharge after removal of mains supply. Before working on the fan controller, ensure isolation of mains supply from line inputs at the fan controller's disconnect if installed (L1, L2/N, L3). Wait three (3) minutes for capacitors to discharge to safe voltage levels. Failure to do so may result in personal injury or death. Note: Darkened display LEDs are not an indication of safe voltage levels.

**CAUTION:** It is the sole responsibility of the installer to verify the operating voltage of the fan system prior to installation! It is also mandatory that the installer verify that airfoils, motor hub assemblies, and fan controllers are matched properly at the time of installation, especially if multiple fan systems will be installed.

**CAUTION:** An incorrectly installed controller can result in component damage or reduction in the fan's life. Wiring or application errors such as under-sizing the controller, incorrect or inadequate AC supply, or excessive ambient temperatures may result in a malfunction of the fan system. Verify correct voltage, phase, and horsepower before beginning installation!

**WARNING:** Exercise caution and common sense when powering the fan. Do not connect the fan to a damaged or hazardous power source. Do not attempt to resolve electrical malfunctions or failures on your own. Contact Big Ass Fans if you have any questions regarding the electrical installation of this fan.

**CAUTION:** For use with manufacturer-supplied variable frequency drive only. Not for use with other speed control devices!

**CAUTION:** Shielded cable, if applicable, must be landed on motor's ground terminal!

**CAUTION:** To avoid a short circuit, be very careful not to get metal chips in the control!

**CAUTION:** The Big Ass Fans product warranty will not cover equipment damage or failure that is caused by improper installation.

**CAUTION:** If it was determined that a motor frequency less than 60 Hz is optimal for maximum performance of your particular fan model, under no circumstances should the factory programmed maximum frequency command limits be changed. Damage to the fan assembly or loss of warranty coverage can result.

**ATTENTION:** If installing the fan in the United States, the fan must be installed per the following National Fire Protection Association (NFPA) guidelines:

- The fan must be centered approximately between four adjacent sprinklers.
- The vertical distance from the fan to the sprinkler deflector must be at least 3 ft (91.4 cm).
- The fan must be interlocked to shut down immediately upon receiving a waterflow signal from the alarm system.

## Delta secondary

- ⚠ **CAUTION:** Care must be taken when connecting to a three-phase 240/120V secondary as shown below. All fan controller models rely on internal references made between each incoming phase and ground. To prevent nuisance tripping such as Overvoltage and Undervoltage faults, 200–250V, three phase fan controllers should be connected so that the High leg, or “phase B,” terminates on “L2” of the fan controller’s input power terminals.
- ⚠ **CAUTION:** Avoid installations utilizing supply transformers with a 480V delta secondary (ungrounded, corner grounded, open). Proper fan operation cannot be guaranteed due to a lack of proper phase-to-ground voltage references.

There are many different arrangements available for industrial and commercial power distribution in North America. The most common are the following:

- **575V/330V Three-Phase (Wye Secondary).** Provides 575V between phases, and 330V from each phase to Neutral/Ground.
- **480V/277V Three-Phase (Wye Secondary).** Provides 480V between phases, and 277V from each phase to Neutral/Ground.
- **208V/120V Three-Phase (Wye Secondary).** Provides 208V between phases, and 120V from each phase to Neutral/Ground.
- **240V/120V Three-Phase (Delta Secondary).** Provides 240V between phases for three-phase loads, 120V from phase “A” and “C” to Neutral/Ground, and 208V from phase “B” to Neutral/Ground as shown below. In this transformer arrangement, phase “B” is commonly referred to as a “Wild Leg” or “High Leg,” and shall be marked accordingly with an orange finish or other effective means per NEC 110.15.

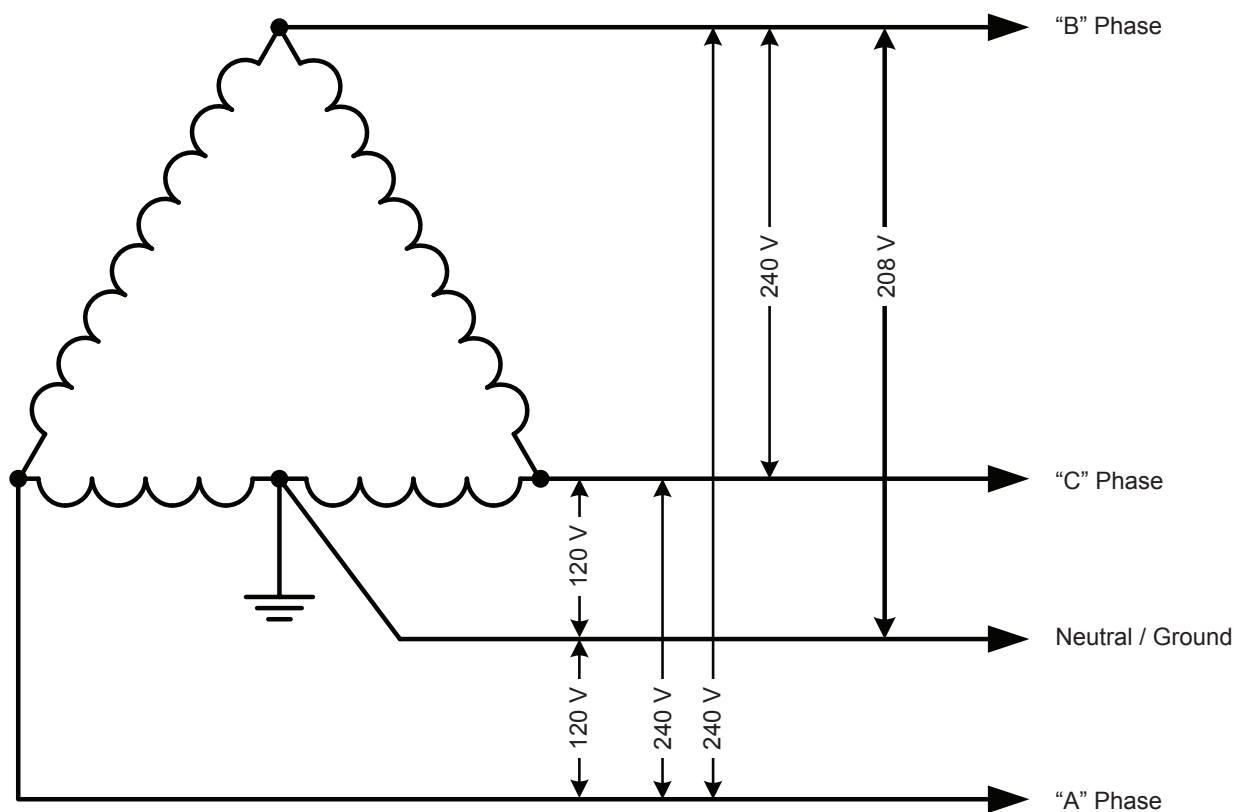

## 28

## Electrical Installation (cont.)

**Branch circuit protection**

The fan controllers include fuses for branch short circuit protection. If desired, these fan controller models can be installed with a dedicated fusible disconnect and/or input circuit breaker. National and local industrial safety standards and/or electrical codes may determine additional requirements for these installations.

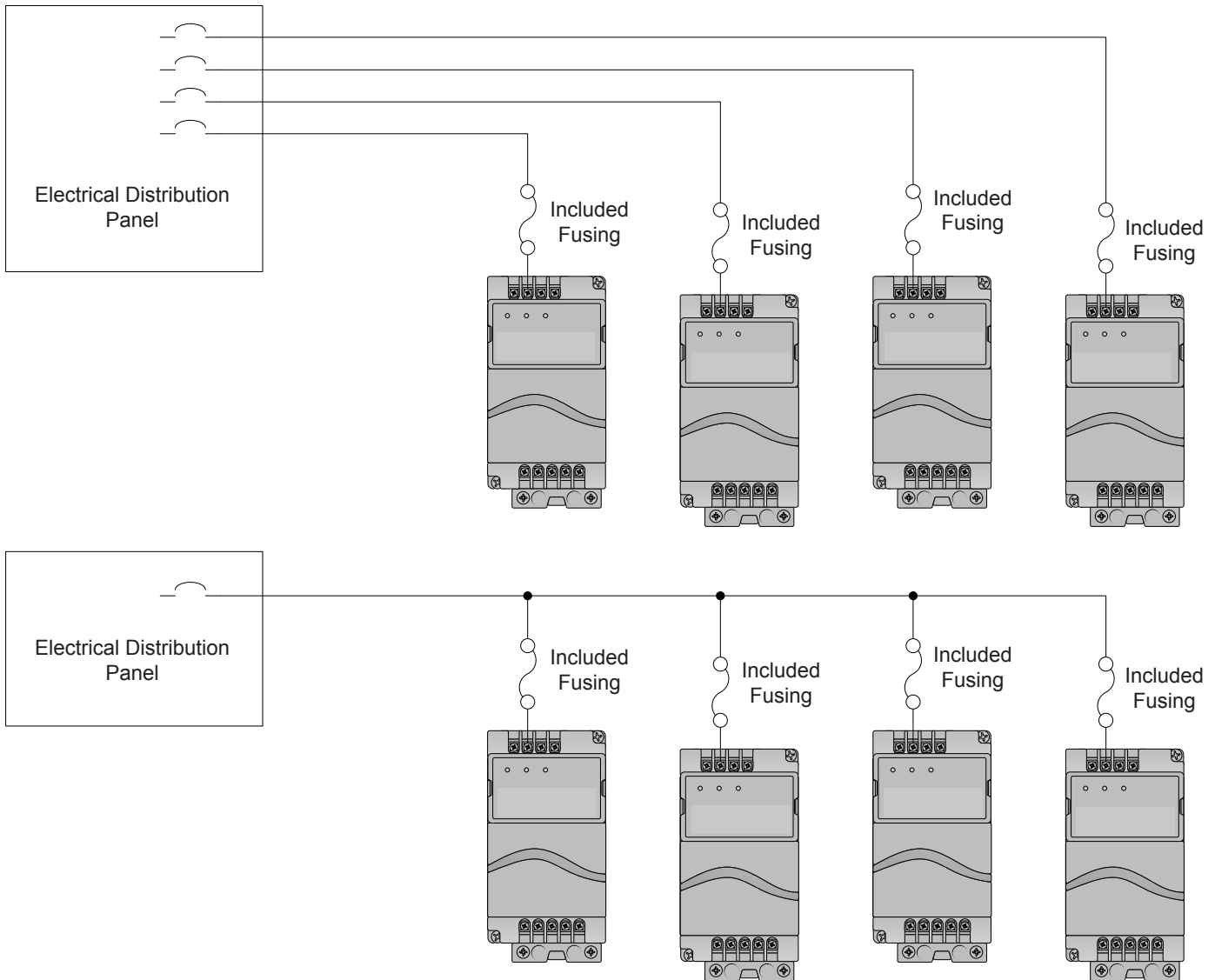

## Mounting the variable frequency drive (VFD)

- ⚠ **WARNING:** Ensure power is disconnected before installing the VFD!
- ⚠ **WARNING:** To avoid damaging VFD and fan controller, test the VFD and fan controller with a test cable!
- ⚠ **CAUTION:** To avoid a short circuit, be very careful not to get metal chips in the control!

The VFD enclosure does not provide conduit knockouts. Big Ass Fans recommends using a hole punch to create conduit knockouts in the most accessible locations on the enclosure.

### 1. Select a mounting location

Select a mounting location that is shaded from direct sunlight and allows enough clearance for the door to fully open. The mounting location should be a flat surface that is readily accessible, free from vibration, and an adequate distance from foreign objects or moving equipment.

### 2. Predrill the VFD enclosure

Drill appropriately sized holes in the VFD enclosure to accommodate the conduit connectors. Position the holes where the conduit can most accessibly exit the enclosure. *Note: Use appropriately rated connectors (IP56) to protect against foreign matter from entering the enclosure.*

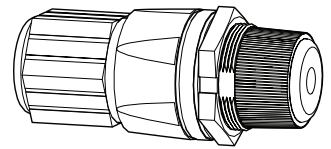

### 3. Mount the VFD enclosure (to the wall)

Mount the VFD enclosure to the wall using the screws provided with the enclosure.

### 4. Wire the fan

Refer to the wiring diagrams on the following pages for your fan controller, and refer to page 34 for the motor wiring. *Note: Wiring is not shown in the illustration below.*

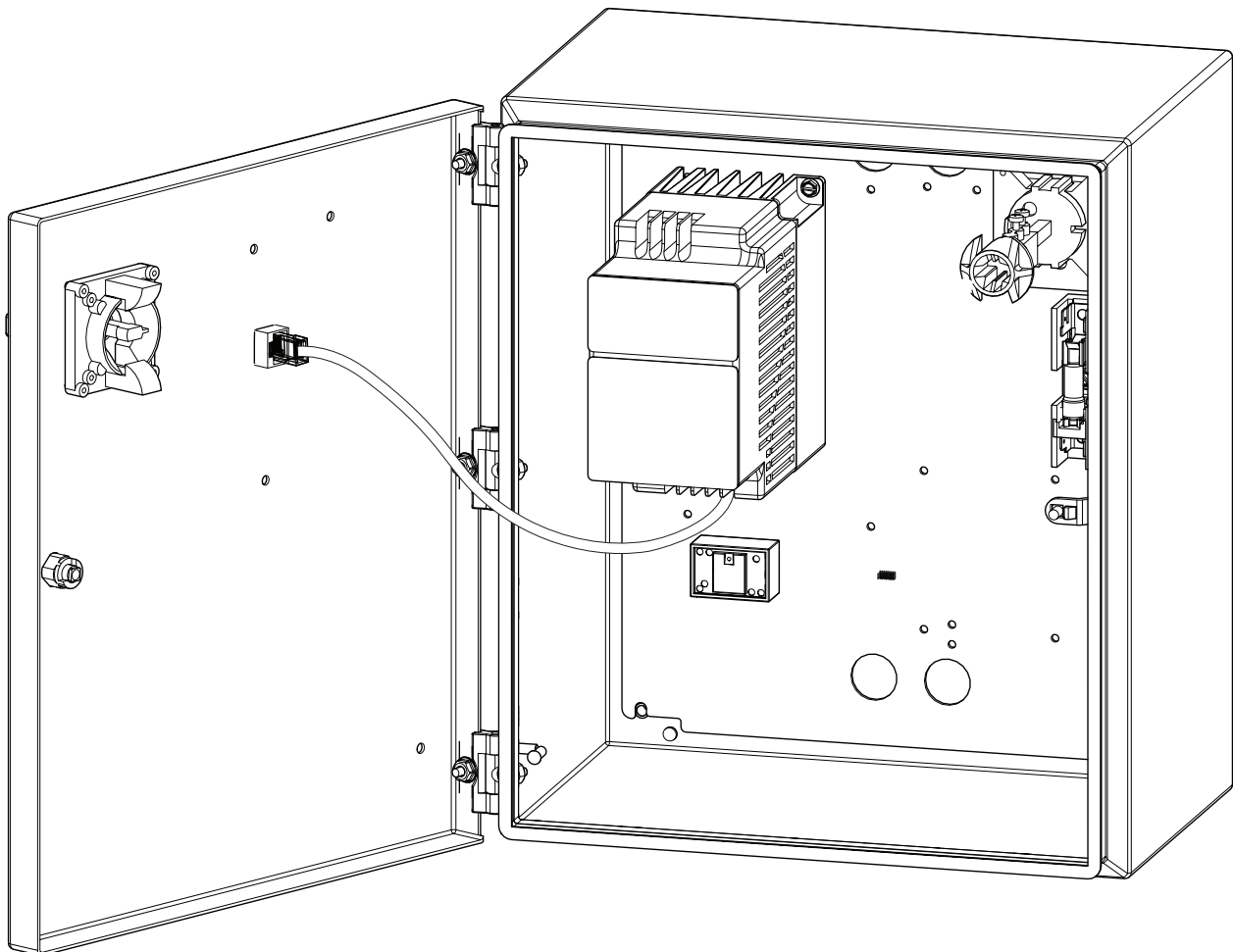

**Wiring: Fan Controller (200V–250V 1Φ, 1 HP)**

- ⚠ **WARNING:** Wait three minutes after disconnecting before servicing!
- ⚠ **WARNING:** Improper installation can cause electric shock or damage to the motor and controller! A qualified electrician should perform the installation.

The diagram below shows a standard fan controller (200V–250V, 1HP) using single-phase input from AC power supply. See pages 2–3 for detailed voltage, current, and circuit breaker/fuse requirements.

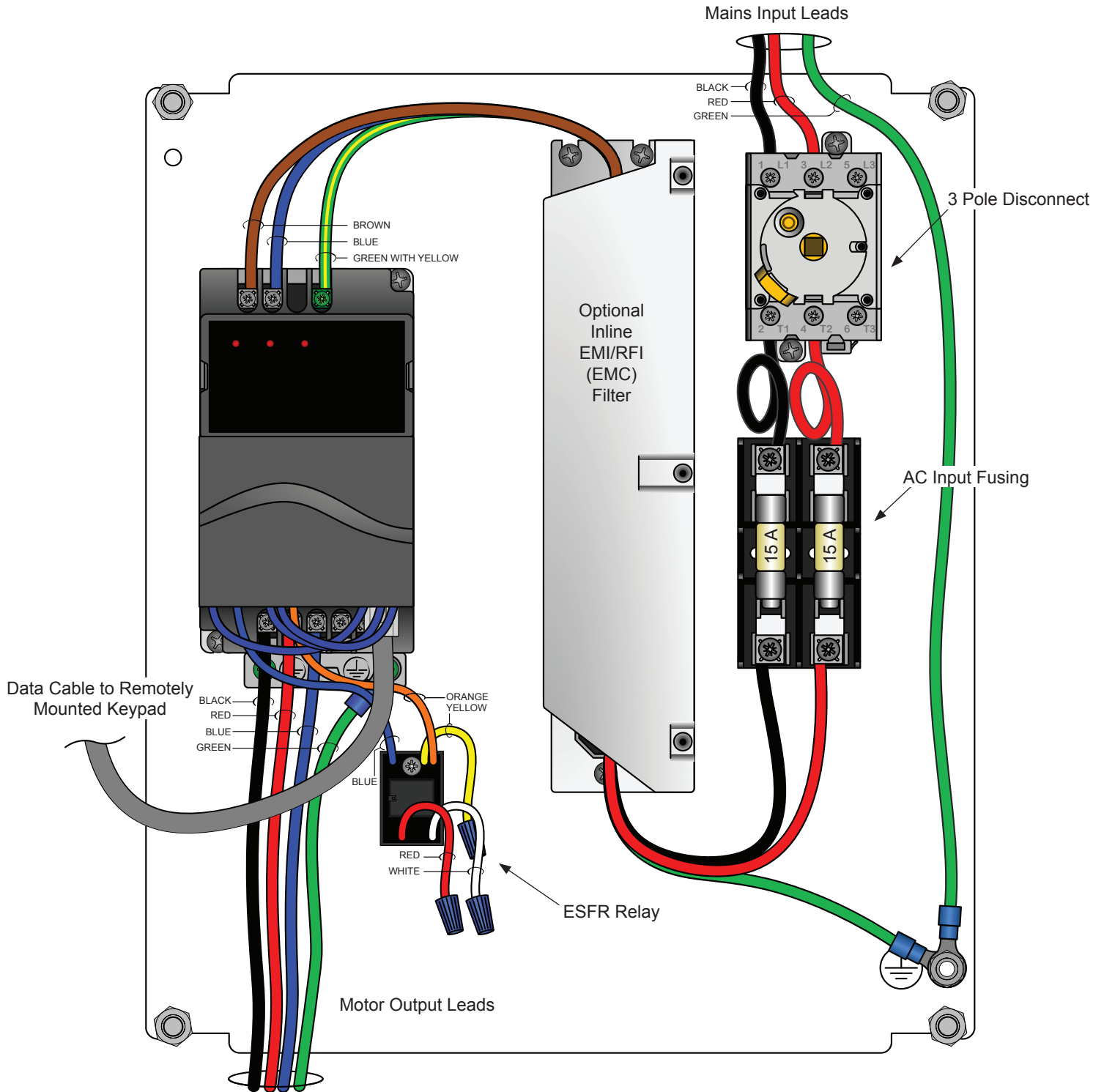

**Wiring: Fan Controller (200V–250V 1Φ, 2HP)**

**⚠ WARNING: Wait three minutes after disconnecting before servicing!**

**⚠ WARNING: Improper installation can cause electric shock or damage to the motor and controller! A qualified electrician should perform the installation.**

The diagram below shows a standard fan controller (200V–250V, 1HP) using single-phase input from AC power supply. See pages 2–3 for detailed voltage, current, and circuit breaker/fuse requirements.

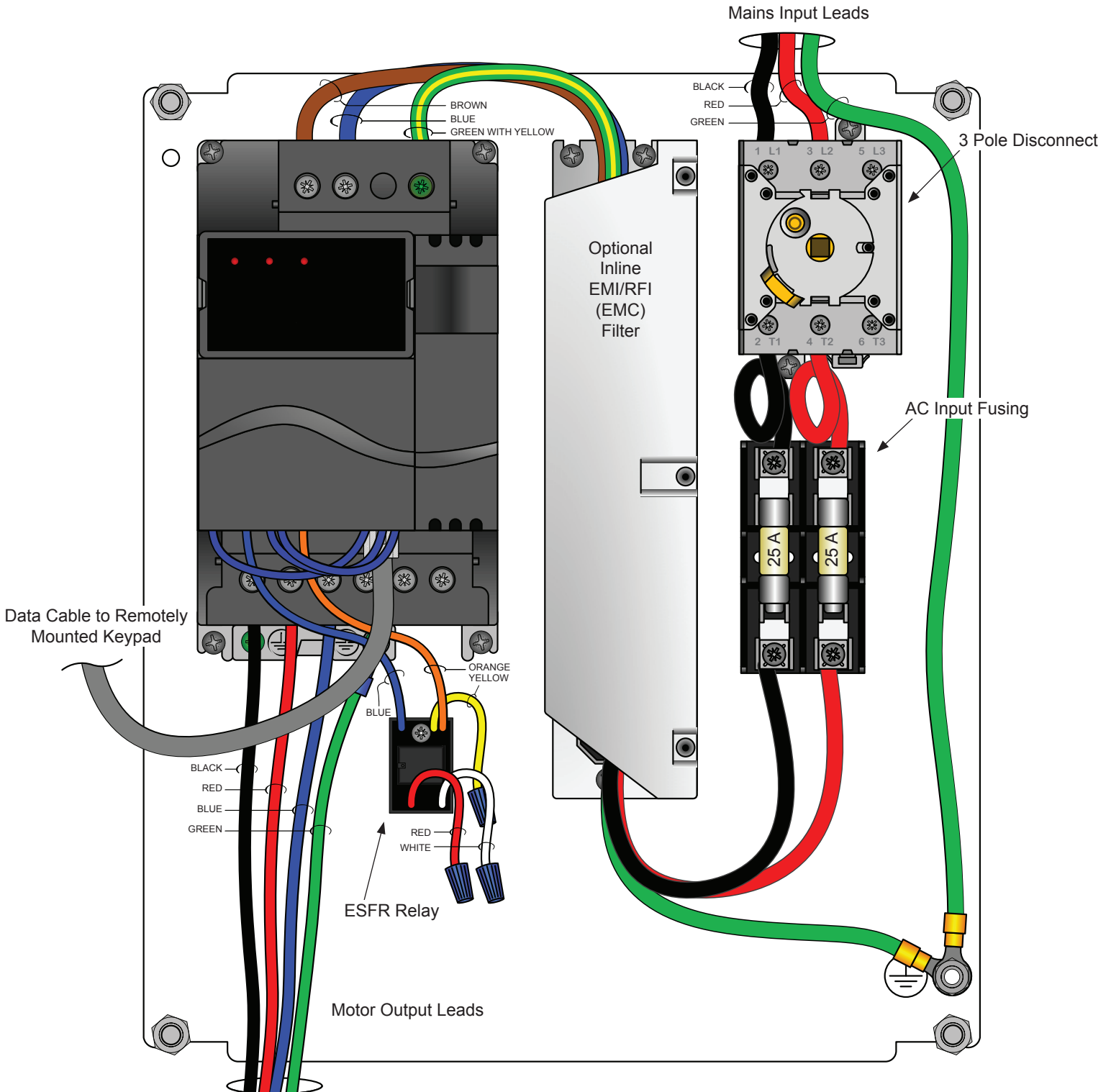

**Wiring: Fan Controller (200V–250V 3Φ, 1 HP and 2 HP)**

- ⚠ **WARNING: Wait three minutes after disconnecting before servicing!**
- ⚠ **WARNING: Improper installation can cause electric shock or damage to the motor and controller! A qualified electrician should perform the installation.**

The diagram below shows a standard fan controller (200V–250V, 1HP and 2HP) using three-phase input from AC power supply. See pages 2–3 for detailed voltage, current, and circuit breaker/fuse requirements.

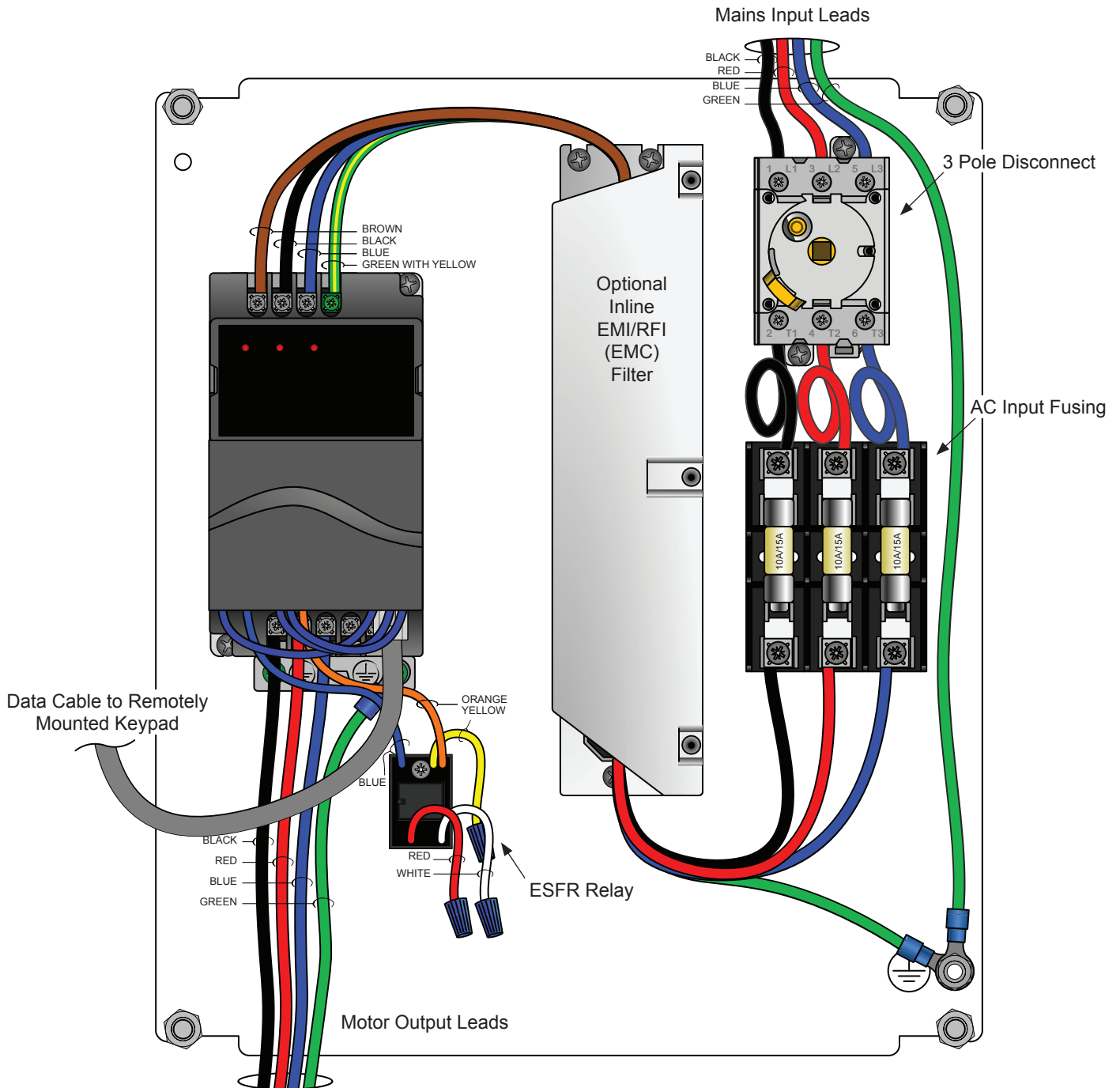



**Wiring: Fan Controller (400V–480V 3Φ, 1 HP and 2 HP)**

- ⚠ **WARNING: Wait three minutes after disconnecting before servicing!**
- ⚠ **WARNING: Improper installation can cause electric shock or damage to the motor and controller! A qualified electrician should perform the installation.**

The diagram below shows a standard fan controller (400V–480V, 1HP and 2HP) using three-phase input from AC power supply. See pages 2–3 for detailed voltage, current, and circuit breaker/fuse requirements.

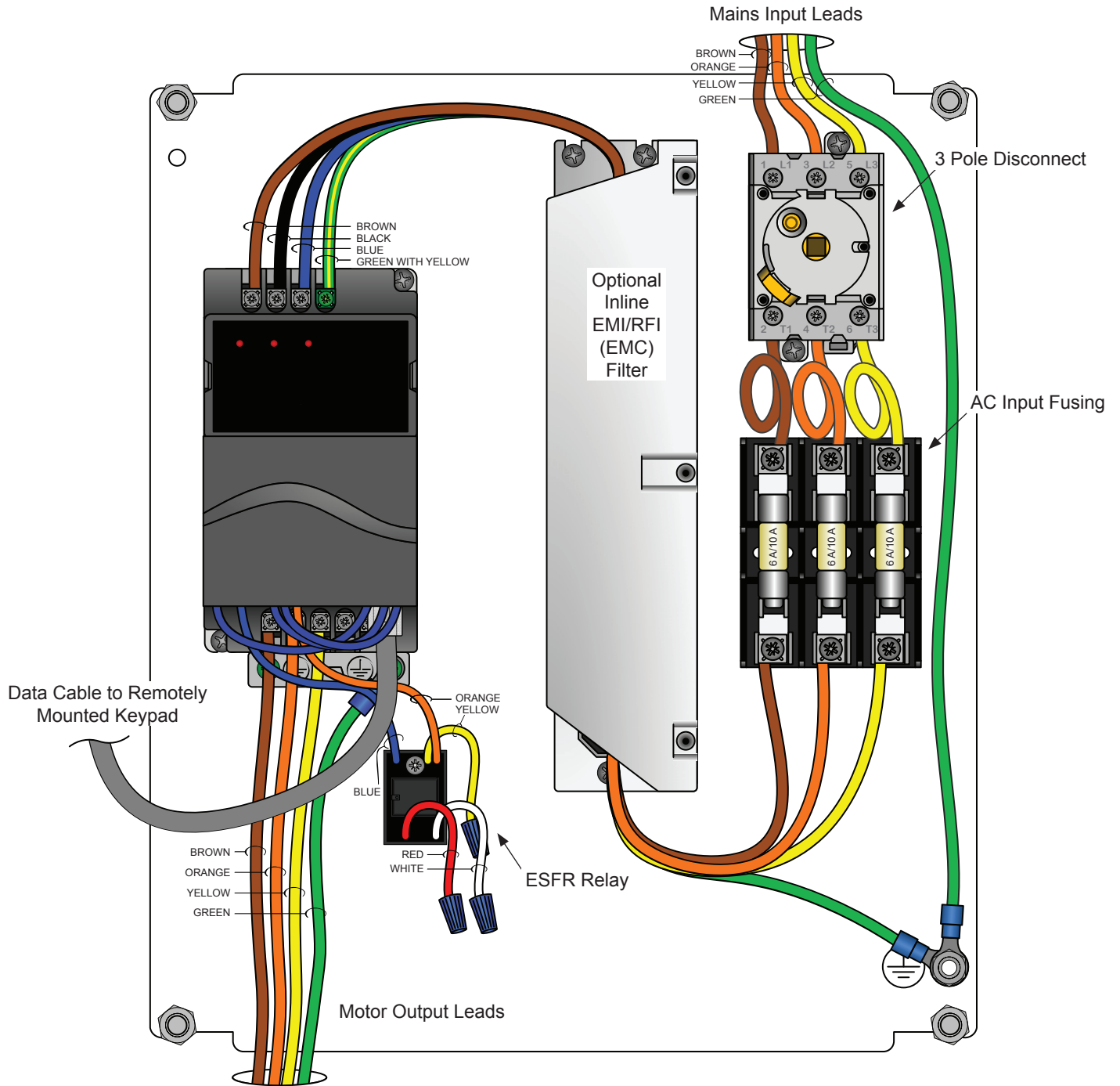

# 34

## Electrical Installation (cont.)

### Wiring: Fan Motor

- ⚠ **WARNING: Wait three minutes after disconnecting before servicing!**
- ⚠ **WARNING: Improper installation can cause electric shock or damage to the motor and controller! A qualified electrician should perform the installation.**

The diagrams below show wiring for low voltage and high voltage systems. These diagrams include L2 and L3 swap to yield proper motor rotation. Motors with terminal blocks require ring terminals and a 7mm nut driver for termination.

Consult the motor wiring nameplate or wiring placard for verification of required wiring connections. See pages 2–3 for detailed voltage, current, and circuit breaker/fuse requirements.

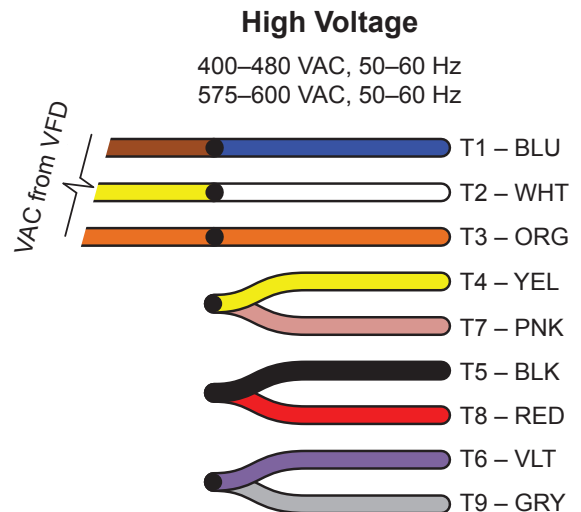
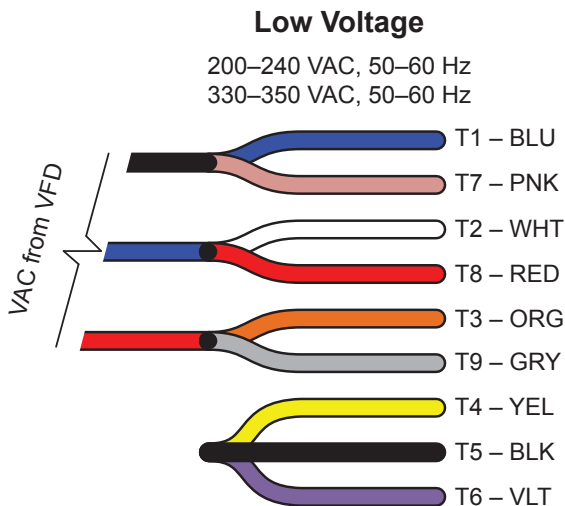
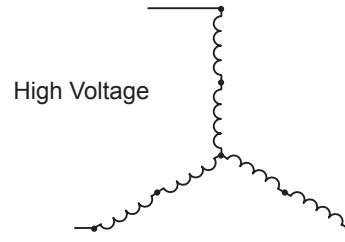
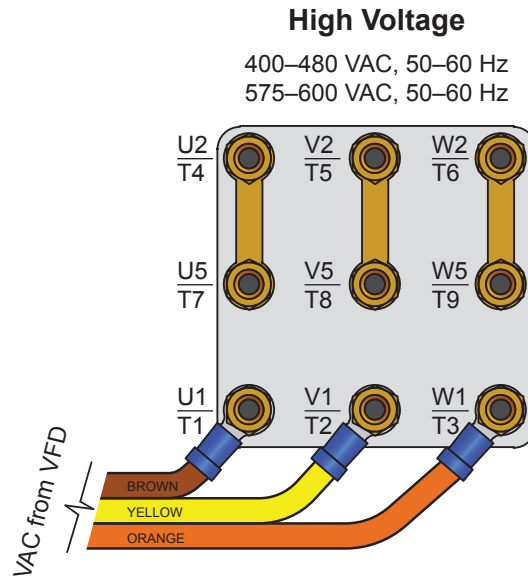
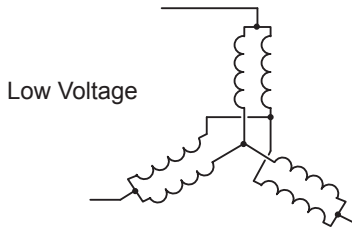
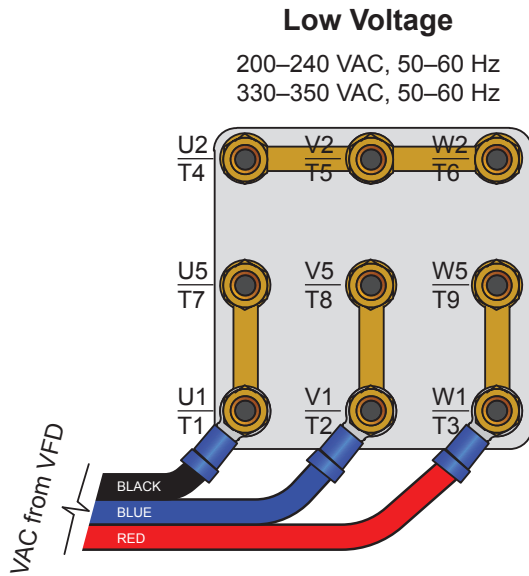

## Daisy Chaining

The Powerfoil®X2.0 fan is preprogrammed to operate in Master/Slave or Daisy Chain mode. Starting, stopping, and speed control signals are transmitted by the master fan controller to remaining slaved fans via 0–10 VDC analog outputs. The wall controller for the slaved fans remains active as a display so that the operator can still view any fault messages, toggle between output frequency and fan RPM displays, or operate the fan via the LOCAL/REM button.



The LOCAL/REM button toggles the fan's command sources between the wall controller (LOC LED illuminated) and external sources (REM LED illuminated). In a daisy chained installation, the master fan controller will operate via the wall controller (local mode), and the Slaved fan controller(s) will operate via the 0–10 VDC command reference provided by the master fan controller (REM mode). *Note: To access the LOCAL/REM button, the controller cover must be removed.*

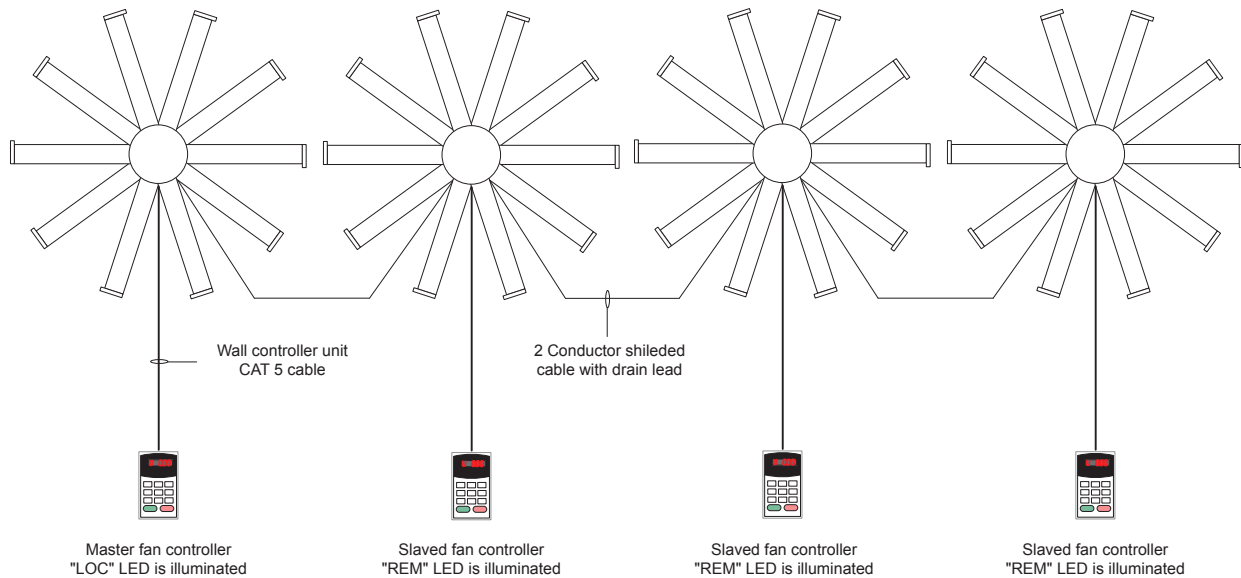

In the example above, the first controller is the master controller (local mode). The remaining fans (REM mode), when connected with a two-conductor shielded cable, will follow command references provided by the master controller. See the following page for detailed wiring diagrams. Limit two-conductor shielded cable runs to 200 ft (61 m) or less. Consult Big Ass Fans Customer Service Department for conversion to 4–20 mA current loop.

## System redundancy

If one of the fans in the chain is disabled, the next fan controller in the chain can become the master controller for all remaining fans by pressing the LOCAL/REM button on that fan's wall controller.

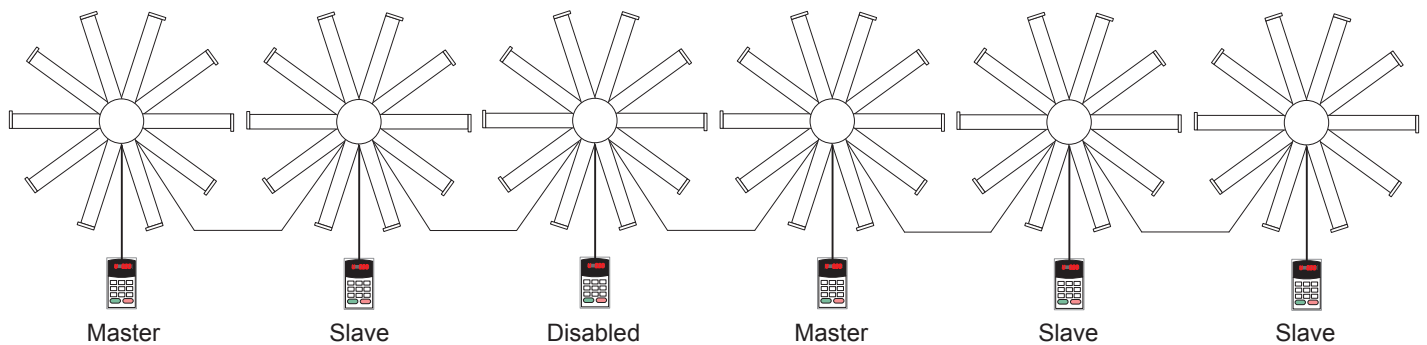

Daisy chaining (cont.)

Reverse fan rotation is disabled when the fan is operated as a slaved unit. *Note: To access all buttons on the controller, the controller cover must be removed.*

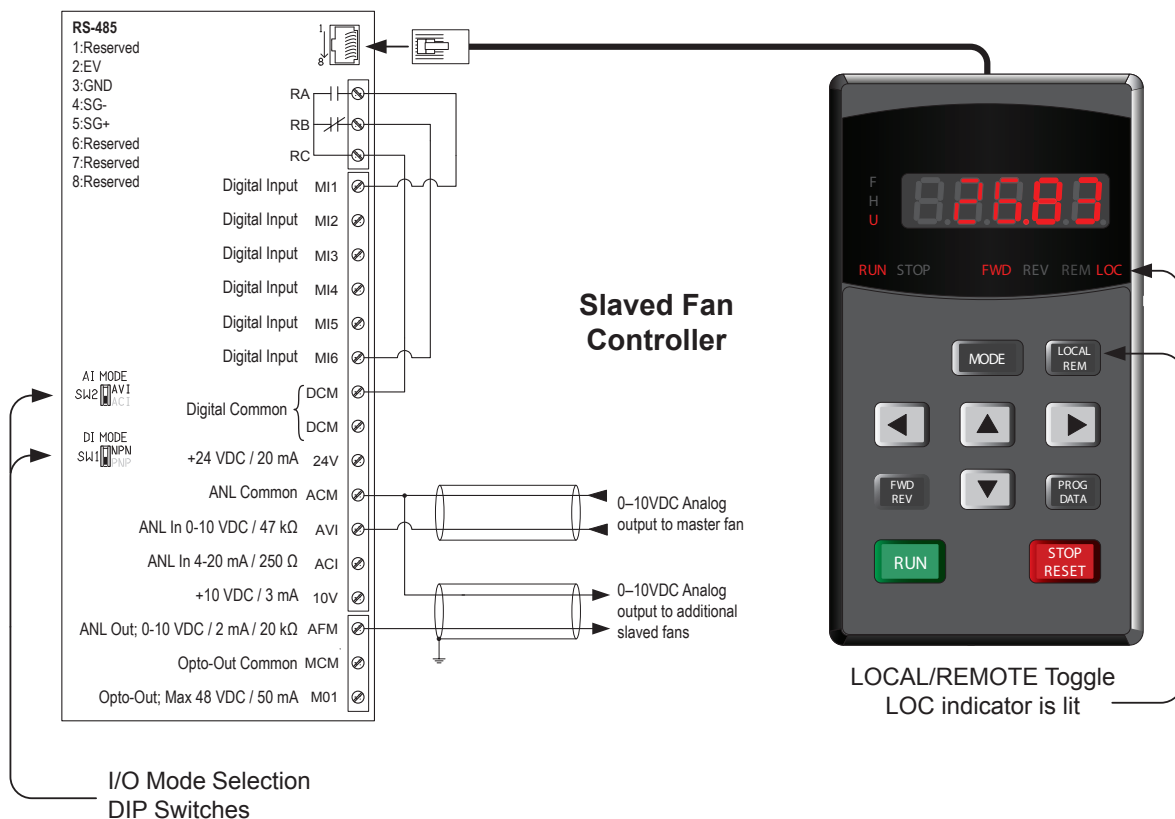
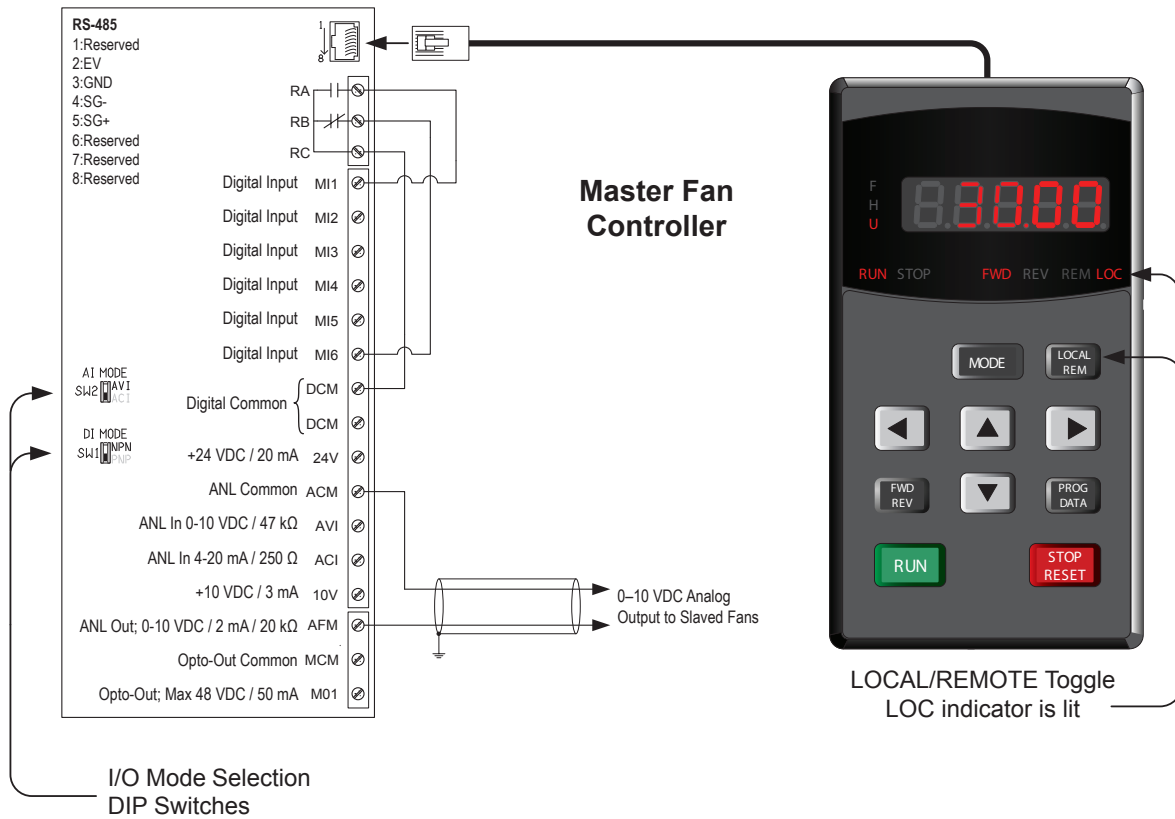

**Basic Distributed I/O Interface; LOCAL Control**

Note: RA to Digital Input #1 jumper removed.

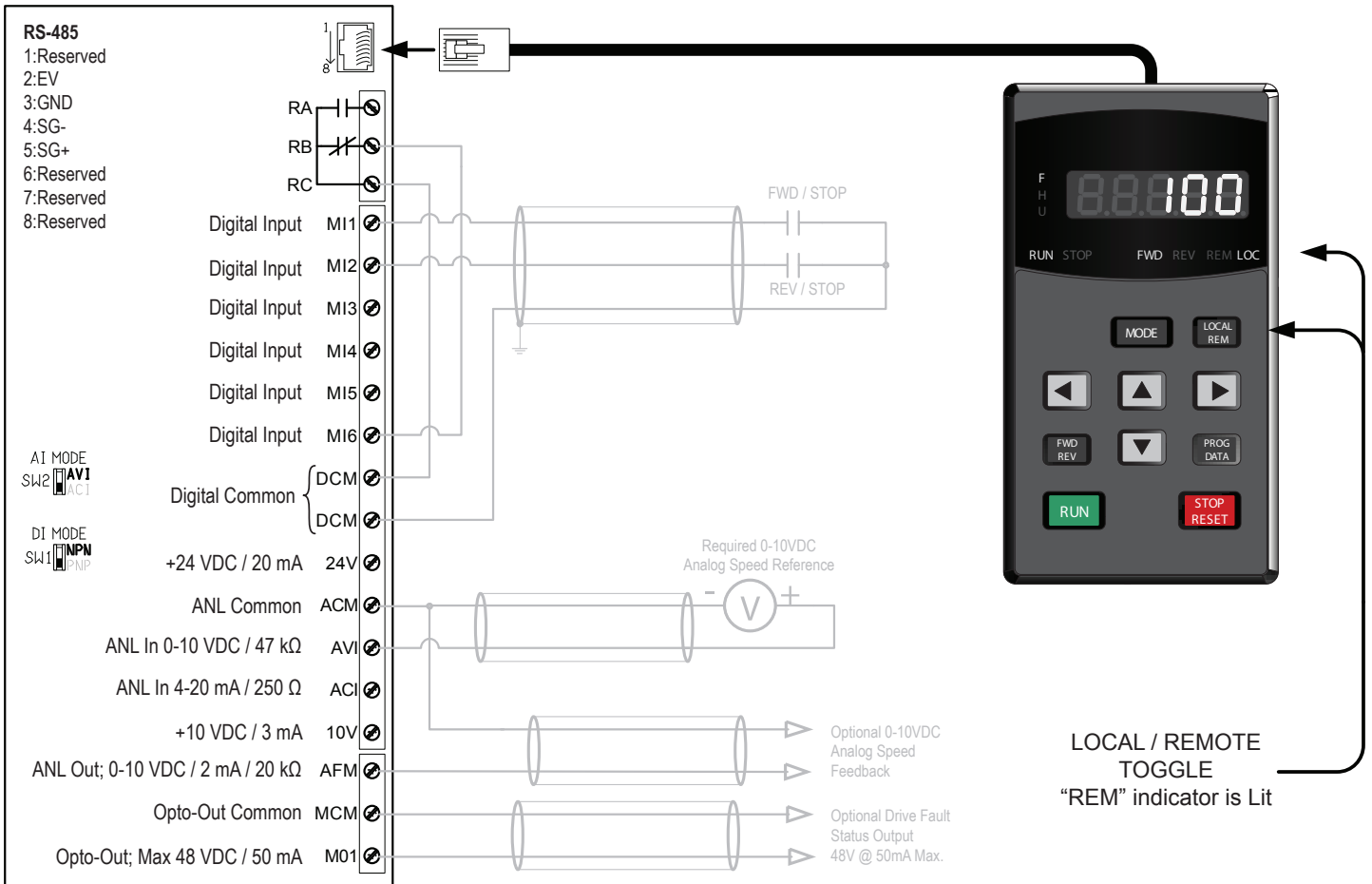

The Powerfoil® X2.0 fan is programmed to be controlled via the included wall controller, which starts, stops, and performs speed control duties for the fan. Fault messages and toggling between output frequency and fan RPM displays are also controlled by the wall controller. This mode of operation is commonly referred to as “local control.”

**\*For the wall control unit to be active, the LOC indicator light must be illuminated by pressing the LOCAL/REM button.**

**Basic Distributed I/O Interface; EXTERNAL Control**

Note: RA to Digital Input #1 jumper removed.

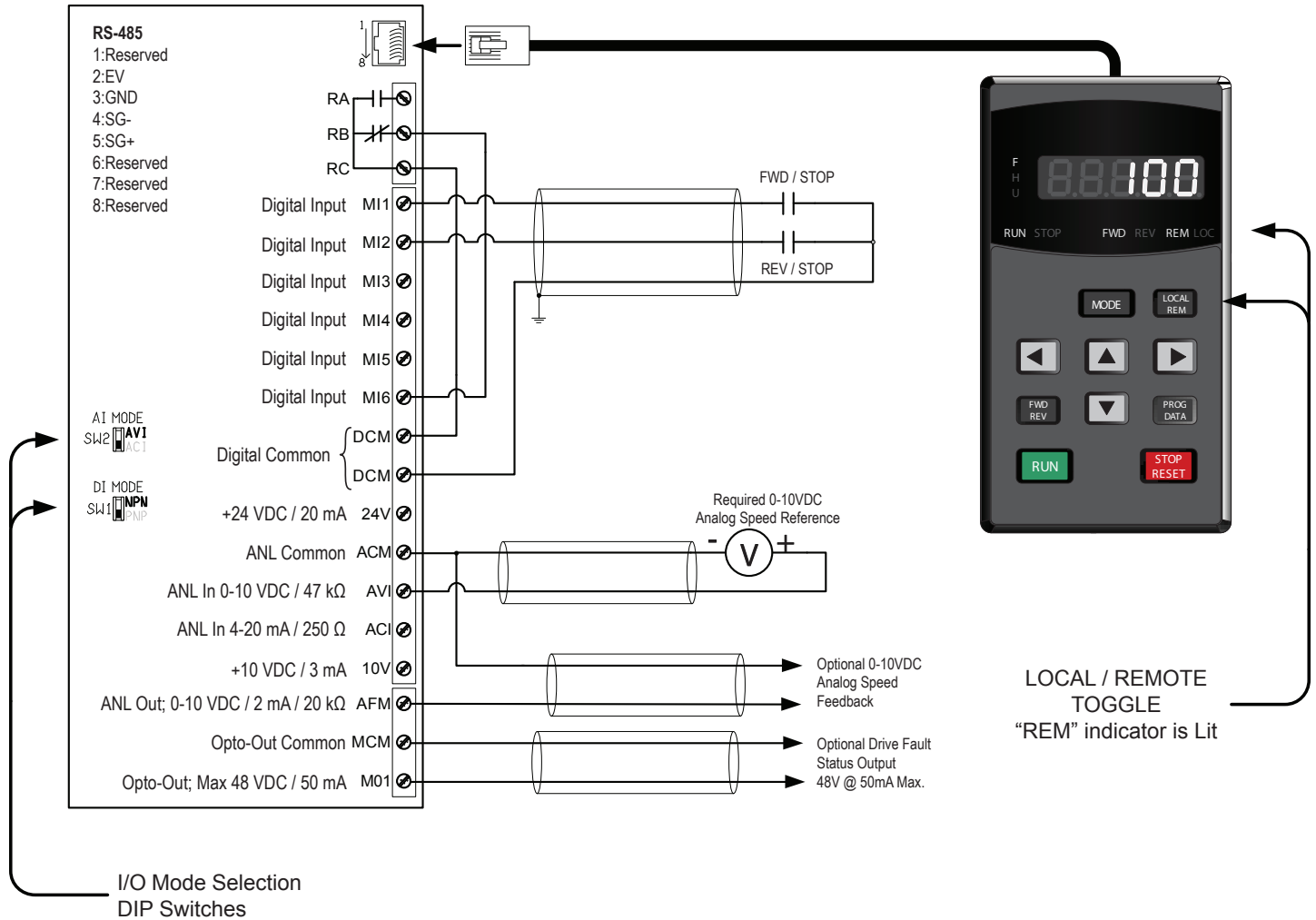

The Powerfoil® X2.0 fan is also programmed to be controlled by an Energy Management System or Building Automation System. Starting, stopping, and speed control duties are handled by the distributed I/O (2 N.O. contacts, 1 analog) provided by the installer. The wall controller remains active as a display so that fault messages can still be viewed, and toggling between output frequency and fan RPM displays can still be performed. This mode of operation is commonly referred to as “external control.”

**\*For distributed I/O to be active, the REM indicator light must be illuminated by pressing the LOCAL/REM button as shown above.**

**About I/O Mode Selection**

Big Ass Fans factory defaults for analog and digital inputs are ACI (4-20 mA) and NPN (inputs pulled down to DC Common). If required, these may be switched to AVI (0-10 VDC as shown above) and PNP (inputs pulled up to 24 VDC) via the dip switches shown above. If required, a diagram can be provided to reflect these alternate connection schemes.

## Interfacing with basic timers, thermostats, and other equipment

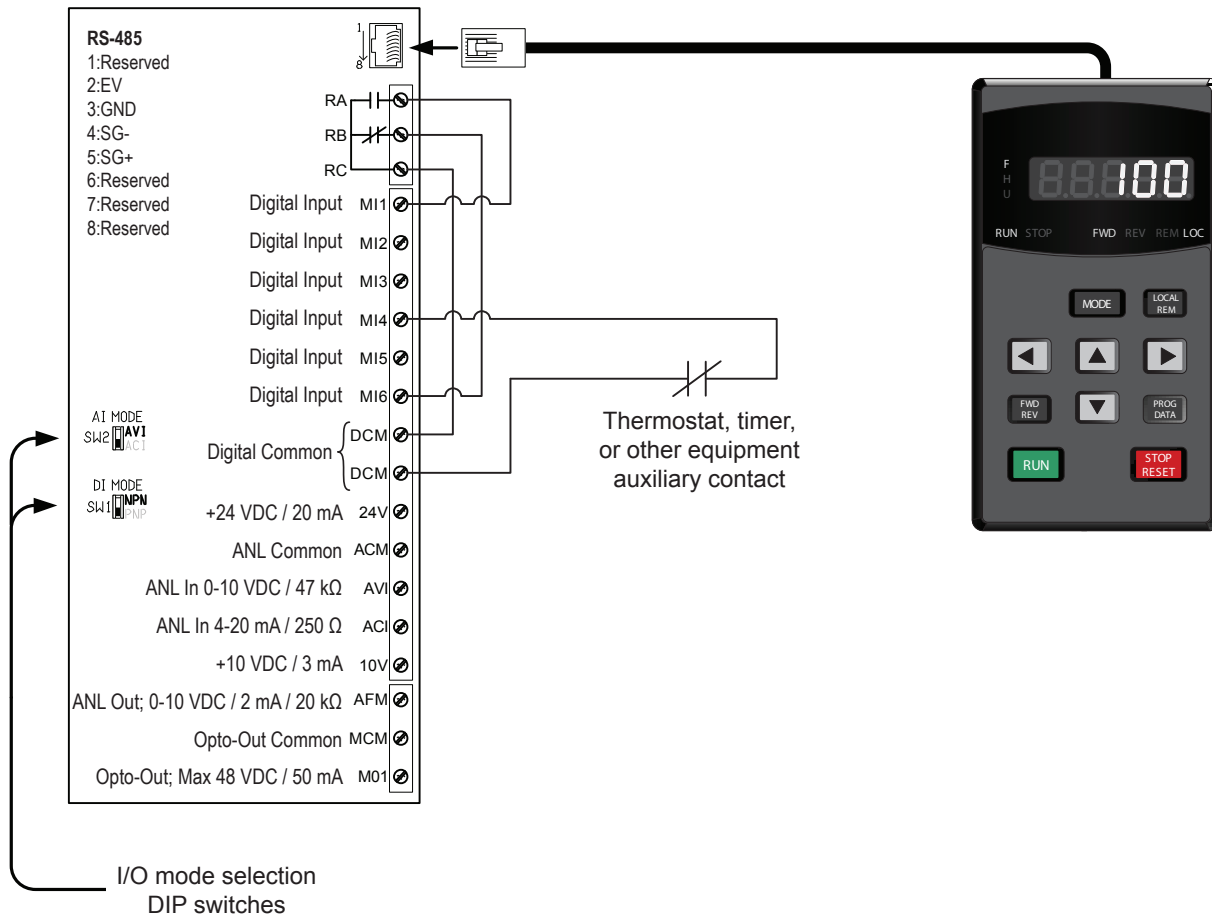

When a contact closure is seen across Digital Input #4 (MI4) and DC Common (DCM), the fan is pre-programmed to issue a base-block code and initiate fan shutdown. This is essentially turning off the fan controller's output terminals, while leaving the fan controller in Run mode.

Auxiliary contacts can be associated with basic timers and thermostats, as well as equipment such as overhead cranes, in order to initiate fan shutdown simultaneously with equipment shutdown when contact closure is seen.

**After the auxiliary contact has reopened, the fan will return to its previous operating mode.**





# Controller Operation

Upon initial power-up of the fan, the controller display appears as shown on the right. The controller is programmed to show the fan's current running speed in RPM on the LED display. The display also indicates if the fan is stopped (STOP), set to run forward (FWD), or is set to respond to a remote control source (REM) such as an Energy Management System or Building Automation System.

Other main LED display modes include Motor Current, Memory Status, Motor Command Frequency, and Motor Actual Frequency. Useful indicators of fan status on the controller are RUN/STOP, JOG, FWD/REV direction, and External or Local Control.

**To operate the fan from the controller**, press the LOCAL/REM button to make sure that the LOC indicator is illuminated. The RUN, STOP, and FWD/REV buttons are functional only when the LOC indicator is illuminated. *Note: To access the LOCAL/REM button on the controller, the controller cover must be removed.*

For error code definitions and corrective actions, see "Fan Error Codes" on page 50.

## Starting, stopping, and direction control

The LOC indicator must be illuminated on the controller in order to start, stop, or change the direction of the fan. *Note: The RUN, STOP/RESET, and FWD/REV buttons are disabled while External Automation Control is enabled (REM LED illuminated).*



*Note: The controller cover is removed in the above illustration.*



**To start the fan**, press the RUN button on the controller's display. When the RUN button is pressed, the STOP LED extinguishes and the RUN LED illuminates while the fan accelerates to the commanded speed.



**To decelerate the fan**, press the STOP/RESET button. The RUN LED will flash, indicating that the controller has accepted the command, and the STOP LED will illuminate.



Proper fan rotation is initially set at the factory. **To reverse the rotation of the fan**, press the FWD/REV button. The fan does not have to be stopped in order to perform this action. When pressed while the fan is running, the FWD or REV LED will flash (current direction), indicating a pending change in fan direction.

## Changing the fan speed

The LOC indicator must be illuminated to adjust fan speed, which can be performed when the fan is stopped or running.



**To change the fan speed**, press the UP and DOWN arrow buttons. The fan speed can be adjusted regardless of what is visible on the LED display, with the exception of the Memory Read/Write screen. When one of the direction keys is pressed, the current display mode is forced to change to the Fan Freq. Command screen as shown below.

*Note: To accelerate this process, press either the LEFT or RIGHT arrow button to select which digit is controlled by the UP and DOWN buttons. Allowing selection of the digit can make changing the fan speed a very fast or very accurate operation. The controller cover must be removed in order to access the LEFT and RIGHT arrow buttons*



## 42

## Controller Operation (cont.)

## Cycling through the LED display modes

MODE

To cycle through the possible display options on the wall controller, press the MODE button repeatedly. Below are the possible screens in the order in which they appear on the display. *Note: To access the MODE button, the controller cover must be removed.*

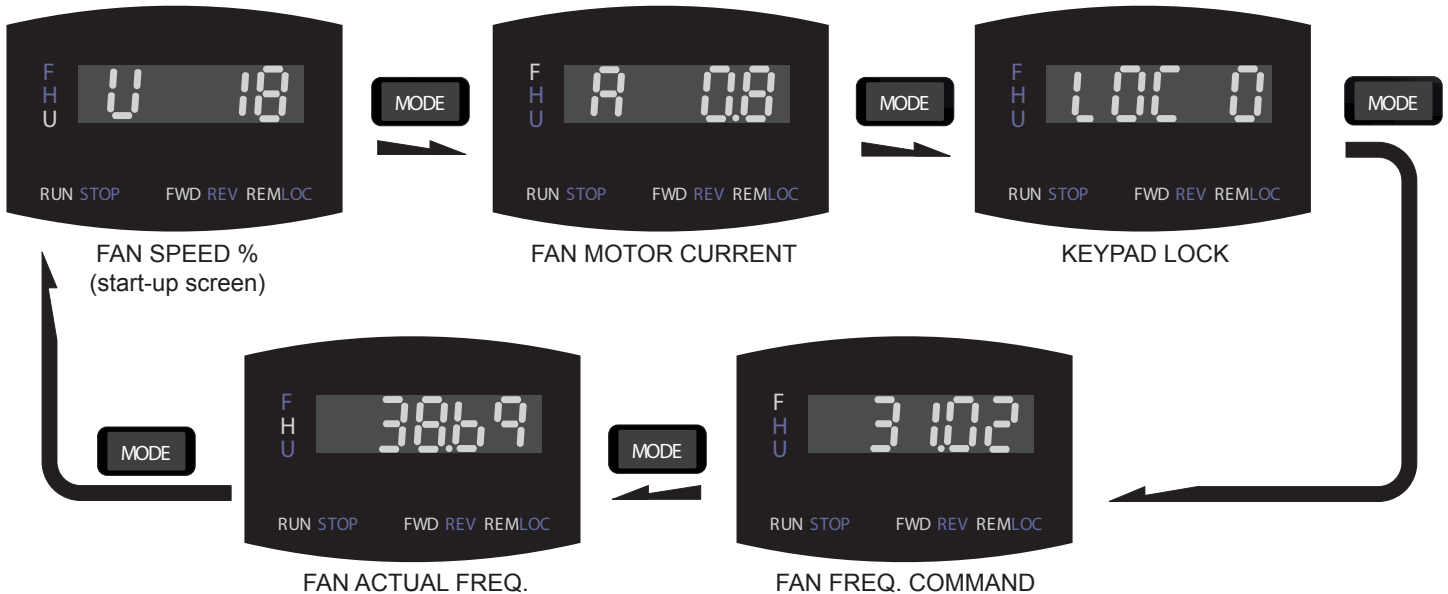

## Toggling the fan's command source

LOCAL  
REM

To select the fan's command source, press the LOCAL/REM button. The fan controller is preprogrammed to accept digital and analog inputs from customer automation systems for start/stop and speed commands, or to be directly controlled from the wall controller. Upon startup, the fan puts priority on external commands provided by automation systems or other fans. *Note: To access all buttons on the controller, the controller cover must be removed.*

To operate the fan from the wall controller, press the LOCAL/REM button to make sure that the LOC indicator is illuminated. The RUN, STOP, and FWD/REV buttons are functional only when the LOC indicator is illuminated. *Note: To access the LOCAL/REM button on the controller, the controller cover must be removed.*

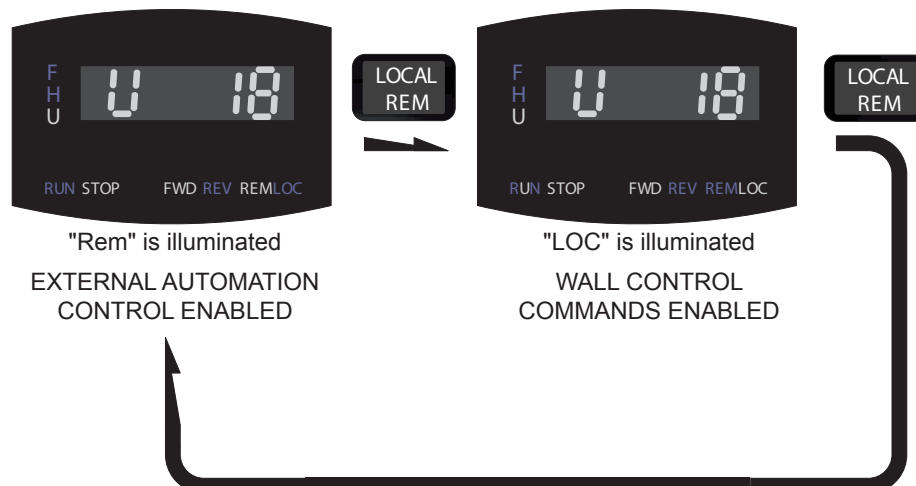

## Understanding and clearing fan faults

---



### External faults

EF or "External Fault" is displayed when the fan has stopped due to an alarm condition. EF also displays if the user has interfaced the fan system with other equipment requiring fan shutdown, such as an ESFR system.



### Internal faults

All other error codes are considered "Internal faults." These codes are specific to problems associated with the fan controller or motor. For example, the error code for "input power phase loss" is shown on the left. For a full list of error codes and their meanings, see "Fan Error Codes" on page 52.



To reset the fan controller, press the STOP/RESET button (after the condition that induced the fault has been cleared).

## Programming and parameter changes

---

**⚠ CAUTION:** Under no circumstances should an operator attempt to alter the programming of the fan's controller without the assistance of an authorized Big Ass Fans installer, the Big Ass Fans Customer Service Department, or the Big Ass Fans Engineering Department.



To access parameters and make changes to the behavior of the fan system, press the PROG/DATA button. If this button is pushed inadvertently, exit programming mode by pressing the MODE button twice to return to the normal operational screen. *Note: To access the PROG/DATA button on the controller, the controller cover must be removed.*

# 44

## Controller Operation (cont.)

### Locking and unlocking procedures

To lock or unlock the wall controller, follow the chart below. *Note: To access the required buttons, the controller cover must be removed.*

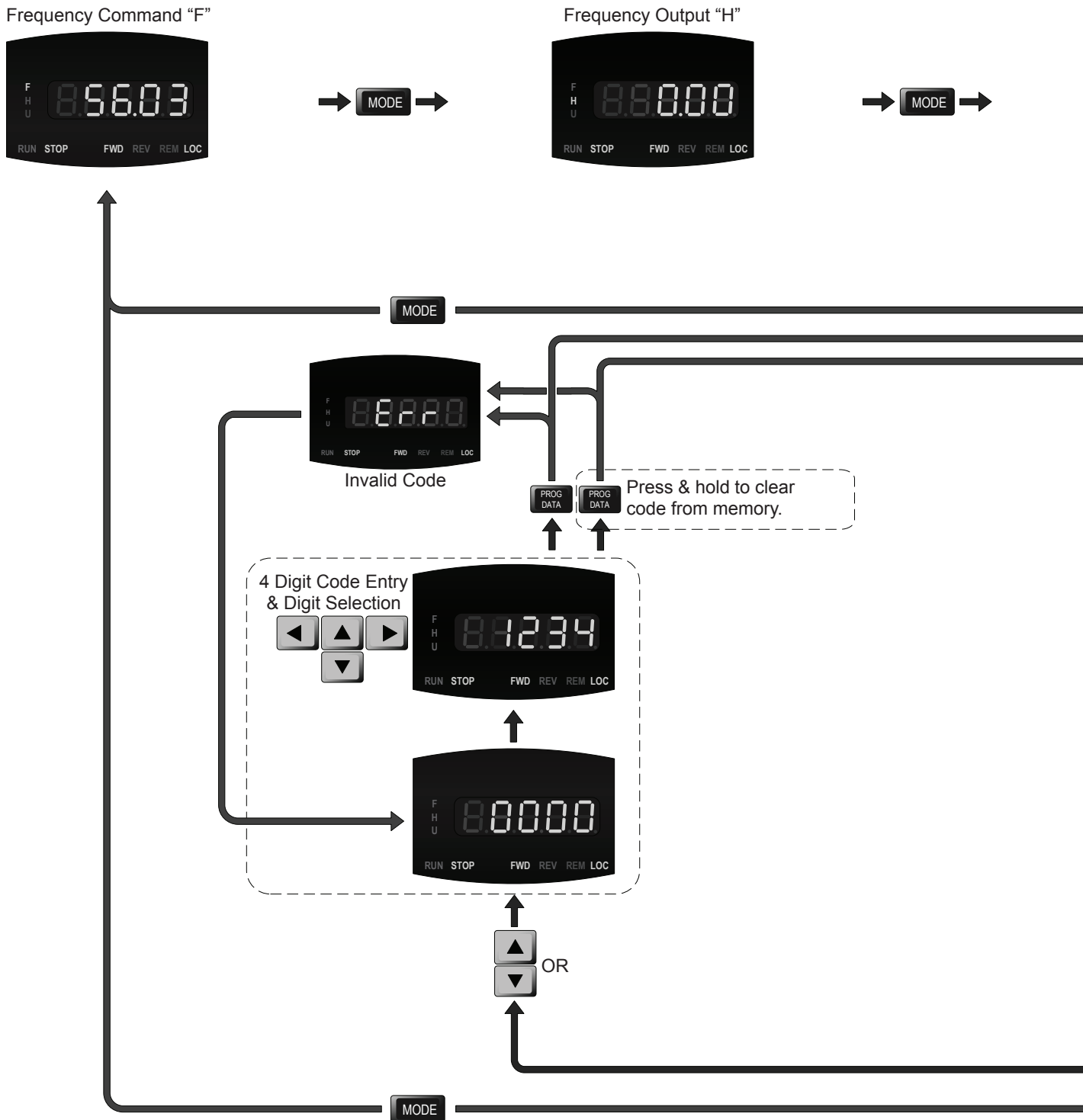

Locking and unlocking procedures

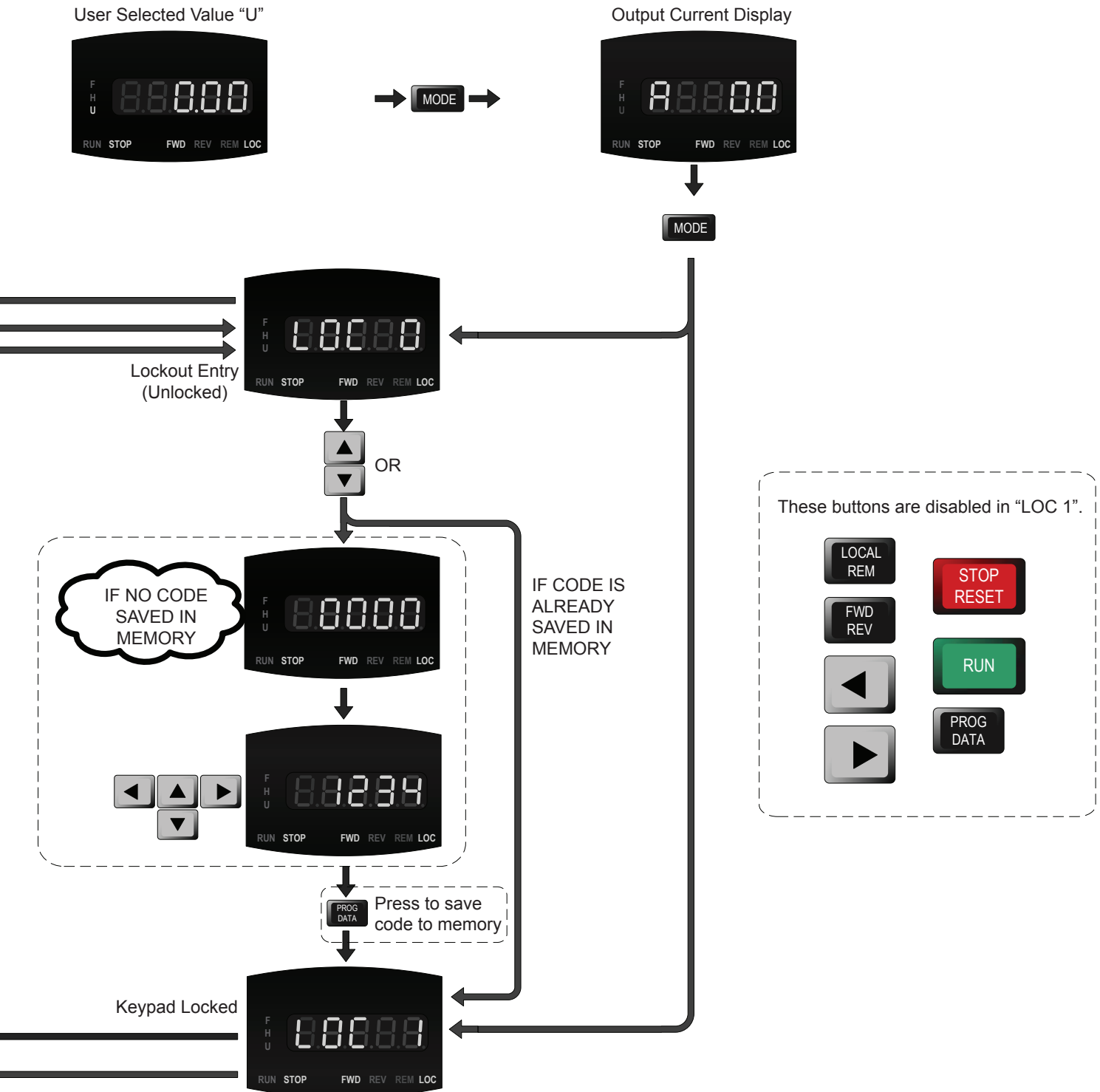

# 46

## Operating the Fan

Big Ass Fans are the highest quality, most meticulously engineered HVLS fans on the planet, moving a lot of air with their size, not speed. Moving at a low speed means less energy used for operation, translating into more energy savings year-round. Follow the procedures below to ensure the most efficient operation of your Big Ass Fan.

### To ensure proper fan rotation:

1. Turn on the fan.
2. Verify that the fan is rotating in the counterclockwise direction (when viewed from below).
3. If the fan is not rotating counterclockwise, reverse the direction of rotation. See page 41 for instructions on changing the direction of rotation.

### Heating season

The Powerfoil®X2.0 fan returns heat from the ceiling to floor level more efficiently than small ceiling fans. For maximum energy savings, the fan should be operated continuously during the heating season and should not be operated in reverse (clockwise). Big Ass Fans are designed to operate efficiently at very low speeds, so turning the fan very slowly in the forward direction (counterclockwise) will provide enough air movement to circulate the hot air at the ceiling down to the floor without causing a draft.

Adjust the fan speed to the appropriate starting fan speed listed in the table below.

Floor-to-ceiling height (ft)	Starting fan speed	Display %
< 40	15 Hz	20–30%
≥ 40	20 Hz	30–40%

Stand directly below the tips of the airfoils with hand outstretched. If you feel a draft, slightly decrease the fan speed by 0.5 Hz (1–2%). Repeat until the draft is no longer noticeable.

### Cooling season

The cooling effect created by the breeze from the Powerfoil X2.0 fan keeps occupants comfortable with the thermostat at a higher setting. During the cooling season, every degree higher that the thermostat is reset reduces the energy consumed by the air conditioner by 1.5–2%. To minimize energy usage during the cooling season, operate the fan only when building occupants are present.

Adjust the fan speed to the appropriate starting fan speed listed in the table below.

Floor-to-ceiling height (ft)	Starting fan speed	Display %
< 40	25 Hz	40–50%
≥ 40	40 Hz	60–70%

Increase the speed of the fan until desired air speed or maximum fan speed is reached. In air conditioned facilities, increase the thermostat setting by 2–7°F to save energy.

# Preventive Maintenance

47

- ⚠ **WARNING:** Risk of fire, electric shock, or injury to persons during cleaning and user-maintenance! Disconnect the appliance from the power supply before servicing.
- ⚠ **WARNING:** Before servicing or cleaning unit, switch off power at service panel and lock the service disconnecting means to prevent power from being switched on accidentally. When the service disconnecting means cannot be locked, securely fasten a prominent warning device, such as a tag, to the service panel.
- ⚠ **WARNING:** When service or replacement of a fan component in the fan requires the removal or disconnection of a safety device, the safety device is to be reinstalled or remounted as previously installed.

Please take a few moments each year to perform the following preventive maintenance inspection on your fan to ensure its safe and efficient operation. Before contacting Customer Service, try resolving the issue using the troubleshooting procedures on page 49. If you have any questions, contact Customer Service. *Note: Actual installation setup may differ from picture.*

## Annual preventive maintenance

Perform the following maintenance procedures each year using the "Maintenance Checklist":

1. Check for the presence of the safety cable and shackle. The cable should be wrapped around the mounting structure, leaving as little slack as possible. The shackle should be securely tightened and located on the topside of the mounting structure.
2. Ensure all (12) mounting bolts are present and torqued to 40 ft·lb (54.2 N·m). Ensure the lower cable is between the brackets of the lower yoke.
3. Inspect motor terminals inside the junction box and tighten if necessary.
4. Check all connections in the fan controller and tighten as needed.
5. Check the gear reducer for oil leakage. If leakage is detected, contact Customer Service.
6. Ensure airfoils are secured to one another by airfoil retainers.
7. Ensure all (20) bolts securing airfoils to fan are present and torqued to 29 ft·lb (39 N·m).
8. Inspect the lower safety cable to ensure it is secure.
9. Inspect the airfoils and main motor unit for signs of damage or cracks.
10. Inspect all fan components for signs of corrosion, discoloration, pitting, and flaking of metal.
11. Check guy wires (if installed) for fraying or damage.

## General preventive maintenance

Periodically perform the following maintenance procedures on your fan:

- Verify proper fan rotation. The fan should be turning counterclockwise when viewed from the floor.
- Dust the airfoils, motor, and motor housing. If desired, use a gentle cleaner or degreasing agent to polish the foils. Do not use Clorox® or other chlorine based cleaners, which could result in the release of toxic/fatal fumes!
- Observe the motion of the fan during operation. The fan should not wobble or precess. If any wobble is noticed, ensure the mounting structure is rigid enough to support the fan and that the guy wires, if used, are sufficiently taut. If guy wires were not used, Big Ass Fans suggests installing them. Contact Customer Service.

- ⚠ **WARNING:** Do not operate a fan with missing or damaged components. Please contact Customer Service.

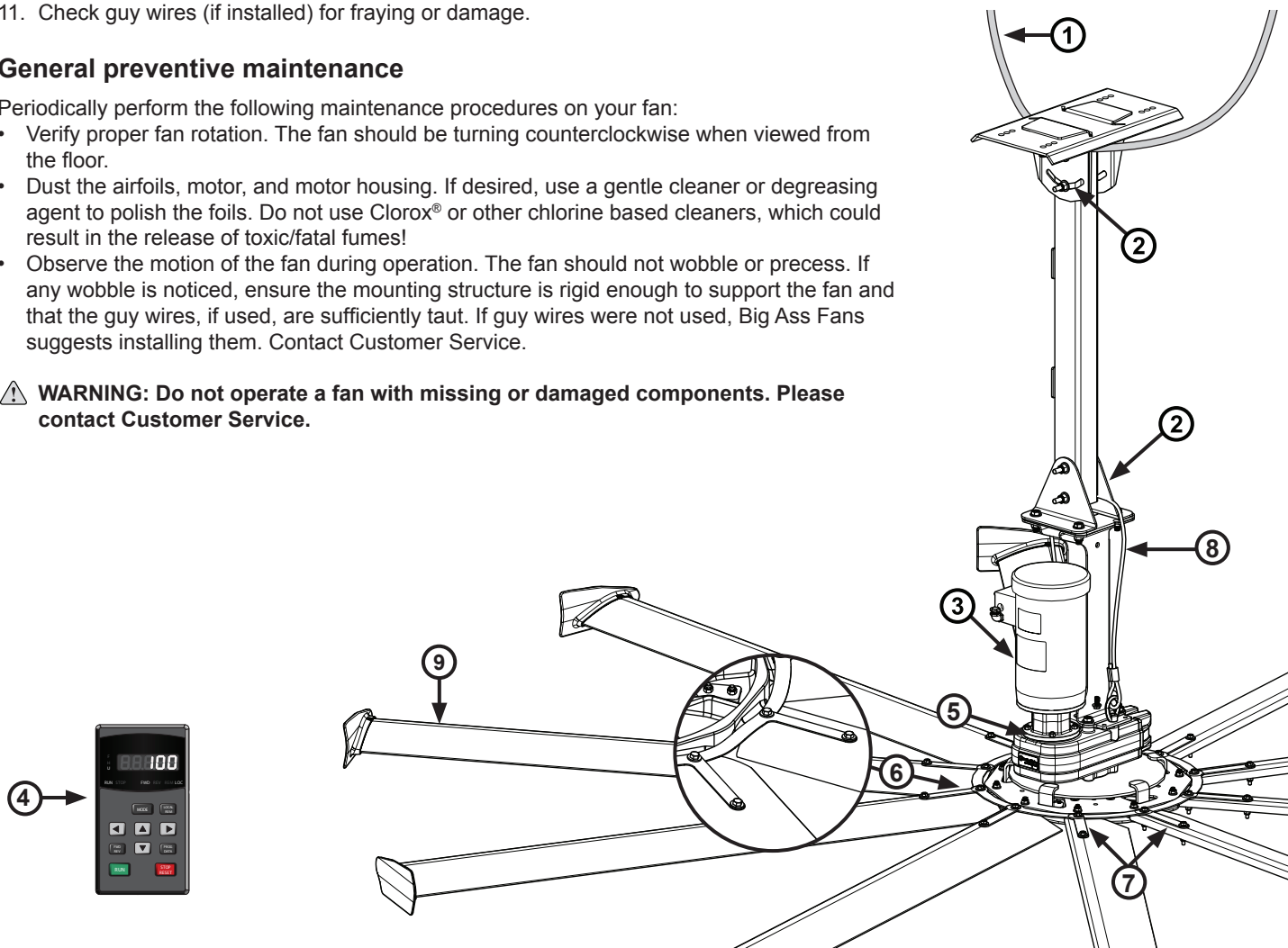









# Troubleshooting

51

## Customers in the United States

For questions about your product or customer service inquiries, please call our toll free number (877-BIG-FANS) or visit [www.bigassfans.com/service](http://www.bigassfans.com/service).

## Customers outside of the United States

For questions about your product or customer service inquiries, please contact your local Big Ass Fans representative or fill out a contact form at [www.bigassfans.com/service](http://www.bigassfans.com/service).

## General troubleshooting

**⚠ WARNING: Risk of fire, electric shock, or injury to persons during cleaning and user-maintenance! Disconnect the appliance from the power supply before servicing.**

Some issues can be resolved before requesting service. Review the below troubleshooting tips before contacting Customer Service for support.

Symptom	Possible solution(s)
<i>The fan is turning in the wrong direction.</i>	To be effective, the fan should be rotating in the counterclockwise direction (when viewed from the floor). If the fan is not rotating in the counterclockwise direction, press the FWD/REV button on the wall controller.
<i>A popping noise is coming from the fan.</i> Airfoil noise is a result of airfoils that are not tightened to the specified torque.	Disconnect the fan from power, and then torque the airfoil hardware to 29 ft·lb (39.3 N·m). If the popping still occurs, verify that the airfoils are not contacting each other. If they are, contact Big Ass Fans Customer Service.
<i>The fan will not start.</i>	Verify the following: <ul style="list-style-type: none"> <li>• Make sure that all wires are securely connected.</li> <li>• Make sure the wall controller is set to RUN and LOC mode.</li> <li>• Verify that supply power is adequate and functional.</li> </ul> <p>If the fan still does not start, contact Customer Service.</p>
<i>The fan controller generates radio frequency noise (RF).</i> Fan controllers generate RF noise in many ways, but this can be prevented using the proper wiring practices outlined in "Electrical Installation" (p. 26).	Verify the following: <ul style="list-style-type: none"> <li>• Do not run your controller and sensitive equipment on the same power line.</li> <li>• Ensure proper grounding at the motor, controller, and from the controller to the utility.</li> </ul> <p>If the noise is still present, contact Customer Service.</p>
<i>The motor makes noise when fan speed is increased.</i> Audible high frequency carrier noise may be an indicator of a stall condition.	Verify motor currents are within limits. See the fan specifications on pages 2–3.
The fan wobbles during operation.	<ul style="list-style-type: none"> <li>• Verify that the mounting structure is rigid enough to support the fan and that the fan is not being exposed to external air forces.</li> <li>• If guy wires were installed, confirm proper installation. If guy wires were not installed, contact Big Ass Fans Customer Service.</li> </ul>

*Note: Some motor, gearbox, or drive noise is to be expected and is normal.*

**E Series fan error codes**

Review the below error codes and corrective actions for your fan controller before contacting Customer Service for support.

Error code	Description and corrective action
OC	<b>Over Current</b> <i>Abnormal condition exists on the motor side of the fan system.</i> Check motor OL point parameters. Check the motor wiring for shorts. If the condition persists with the disconnected motor, contact Customer Service.
OU	<b>High AC Input Voltage</b> <i>Incoming AC line voltage has exceeded acceptable limits or the motor is trying to stop too quickly.</i> Check the DC buss voltage at drive idle versus drive running. Monitor DV buss voltage as the motor is stopping. Verify that incoming AC supply is acceptable configuration (center ground Wye Delta with Wild on B phase).
OH1 OH2	<b>Drive Overtemp</b> <i>Verify the fan is installed in an acceptable environment (122°F [50°C] maximum).</i> Check the drive for excessive dirt buildup on the heat sink fins. Check the drive cooling fan function.
Lu	<b>Under Voltage</b> <i>Incoming AC line voltage has fallen below acceptable limits.</i> Check the DC buss voltage at drive idle versus drive running. Monitor DV buss voltage as the motor is stopping. Verify that incoming AC supply is acceptable configuration (center ground Wye Delta with Wild on B phase).
ocA	<b>Over Current During Acceleration</b> <i>Motor circuit insulation failure or over boosting.</i> Check the torque boost. If the condition persists with a disconnected motor, contact Customer Service.
oL oL1 oL2	<b>Excessive Drive Output Current</b> <i>An abnormal condition exists on the motor side of the fan system.</i> Check the motor OL point parameters. Reduce torque comp (Pr.54).
ocd	<b>Over Current During Acceleration</b> <i>Motor circuit insulation failure or over boosting.</i> Check the torque boost. If the deceleration time is too short, check parameters.
ocn	<b>Over Current During Steady Operation</b> <i>Motor circuit insulation failure or over boosting.</i> Check the motor wiring. This fault could indicate a mechanical failure.
EF	<b>External Fault</b> <i>ESFR input has been triggered (MI3).</i> If the system's building is not on fire, check the relay wiring and the alarm system status. If the building is on fire, vacate the premises immediately! If the SmartSense365™ is in use, 4-20mA loop has been compromised. Check the SmartSense365 power supply and loop wiring. The drive <i>will not</i> auto recover from EF.
GFF	<b>Ground Fault</b> <i>Drive output terminal shorted to ground.</i> Depending on the severity of short, the output module can be damaged (if SCC ≥ 50% of drive rating).
cEO4	<b>Communications Error</b> <i>The drive has been issued a command while in fault status.</i> Clear all active faults before trying to operate the drive.
AErr	<b>Analog Error</b> <i>The ACI switch is active. The drive is searching for a 4-20mA signal, but it is not present or is out of tolerance.</i>
PHL	<b>Incoming Phase Loss</b> <i>Possible loose connections or blown over current devices.</i> Check the incoming AC line for loose connections or blow over current devices.

## E Series fan error codes (cont.)

Error code	Description and corrective action
cF1.0 cF1.1 cF2.0 cF2.1	<b>Internal Memory Error</b> If the power cycle is not resolved, perform a parameter hard reset. If the condition persists, contact Customer Service.
cE10	<b>Communications Error—Slave</b> Verify proper data wiring between the drive's RS485 port and the command source.
bb	<b>Base Block</b> <i>Base Block input (M4) has been triggered.</i> Check the accessory wiring and accessory configuration. The drive will auto-recover to the previous operating state.
FbE	<b>Feedback Signal Error</b> Check the AVI/ACI wiring.
HPF1, HPF2 HPF3, HPF4 cF3.0, cF3.1 cF3.2, cF3.3 cF3.4, cF3.5 AcL codE	<b>Various Unrecoverable Errors</b> If the power cycle will not clear these faults, contact Customer Service.

## Pr.00.04 Diagnostics running display options

Setting	Run screen display
00	(BAF Default) Display user-defined unit
01	Counter value; pulses on TRG terminal
02	Not valid
03	DC buss voltage ( $\div 1.414 =$ approx. AC line)
04	RMS equivalent feedback level (percentage)
05	PID analog feedback level (percentage)
06	Power factor angle of motor (degrees)
07	Output power in kW
08	Motor torque estimate (N·m)
09	VDC at AVI terminal (displayed in volts)
10	mA at ACI terminal (displayed in mA)
11	IGBT temperature (degrees C°)
12	Not valid
13	Not valid
14	Not valid
15	Not valid

**M Series fan error codes**

Review the below error codes and corrective actions for your fan controller before contacting Customer Service for support.

Error code	Description and corrective action
<b>OC</b>	<b>Over Current</b> <i>Abnormal condition exists on the motor side of the fan system.</i> Check motor OL point parameters. Check the motor wiring for shorts. If the condition persists with the disconnected motor, contact Customer Service.
<b>OV</b>	<b>High AC Input Voltage</b> <i>Incoming AC line voltage has exceeded acceptable limits or the motor is trying to stop too quickly.</i> Check the DC buss voltage at drive idle versus drive running. Monitor DV buss voltage as the motor is stopping. Verify that incoming AC supply is acceptable configuration (center ground Wye Delta with Wild on B phase).
<b>OH</b>	<b>Drive Overtemp</b> <i>Verify the fan is installed in an acceptable environment (122°F [50°C] maximum).</i> Check the drive for excessive dirt buildup on the heat sink fins. Check the drive cooling fan function.
<b>LV</b>	<b>Under Voltage</b> <i>Incoming AC line voltage has fallen below acceptable limits.</i> Check the DC buss voltage at drive idle versus drive running. Monitor DV buss voltage as the motor is stopping. Verify that incoming AC supply is acceptable configuration (center ground Wye Delta with Wild on B phase).
<b>OL</b> <b>OL1</b> <b>OL2</b>	<b>Excessive Drive Output Current</b> <i>An abnormal condition exists on the motor side of the fan system.</i> Check the motor OL point parameters. Reduce torque comp (Pr.54).
<b>ocA</b>	<b>Over Current During Acceleration</b> <i>Motor circuit insulation failure or over boosting.</i> Check the torque boost. If the condition persists with a disconnected motor, contact Customer Service.
<b>ocd</b>	<b>Over Current During Acceleration</b> <i>Motor circuit insulation failure or over boosting.</i> Check the torque boost. If the deceleration time is too short, check parameters.
<b>ocn</b>	<b>Over Current During Steady Operation</b> <i>Motor circuit insulation failure or over boosting.</i> Check the motor wiring. This fault could indicate a mechanical failure.
<b>EF</b>	<b>External Fault</b> <i>ESFR input has been triggered (MI3).</i> If the system's building is not on fire, check the relay wiring and the alarm system status. If the building is on fire, vacate the premises immediately! If the SmartSense365™ is in use, 4-20mA loop has been compromised. Check the SmartSense365™ power supply and loop wiring. The drive <i>will not</i> auto recover from EF.
<b>GFF</b>	<b>Ground Fault</b> <i>Drive output terminal shorted to ground.</i> Depending on the severity of short, the output module can be damaged (if SCC ≥ 50% of drive rating).
<b>FbE</b>	<b>Feedback Signal Error</b> Check the AVI/ACI wiring.
<b>PHL</b>	<b>Incoming Phase Loss</b> <i>Possible loose connections or blown over current devices.</i> Check the incoming AC line for loose connections or blow over current devices.
<b>bb</b>	<b>Base Block</b> <i>Base Block input (M4) has been triggered.</i> Check the accessory wiring and accessory configuration. The drive will auto-recover to the previous operating state.

## M Series fan error codes (cont.)

Error code	Description and corrective action
HPF1, HPF2 HPF3, HPF4 cF3.0, cF3.1 cF3.2, cF3.3 cF3.4, cF3.5 AcL codeE	<b>Various Unrecoverable Errors</b> If the power cycle will not clear these faults, contact Customer Service.
cF1 cF2	<b>Internal Memory Error</b> If the power cycle is not resolved, perform a parameter hard reset. If the condition persists, contact Customer Service.
cE1	<b>Communications Error—Slave</b> Verify proper data wiring between the drive's RS485 port and the command source.

## Pr.64 Diagnostics running display options

Setting	Run screen display
00	Display drive output frequency (Hz)
01	(Default) User-defined number (Hz x PR.65)
02	RMS equivalent output voltage to motor
03	DC buss voltage ( $\div 1.414$ = approx. AC line)
04	PV (i)
05	Display internal counter value
06	Display the settings frequency (F or 0 = %)
07	Display parameter setting
08	Reserved/Not valid
09	Output current to motor
10	Display program operation (0.xxx)

# 56

# Warranty Return Instructions

Congratulations on your purchase of a Big Ass Fan! We are delighted that you have chosen our product to improve the quality of your indoor environment, and hope you'll have much pleasure using the fan for years to come.

## **Replacement of products under warranty return instructions**

---

If you believe a part failed during normal operation and is covered under warranty, Big Ass Fans will ship a replacement part to you pursuant to your notice that you will be replacing the original part within 10 days. The replacement part will be shipped to you prior to our receipt of the item that failed, and prior to our evaluation of this part to determine the reasons for its failure and whether it is covered under warranty.

In order to evaluate the cause of the product failure, we will need you to return the original part to our offices within 10 working days of receipt of the replacement part. Should the part be covered under warranty, you will not be charged for the replacement item; however, you will be charged for the replacement part plus shipping if (1) the part is not under warranty because the source of failure is outside the scope of the warranty, or (2) the warranty period has expired. If there is no warranty coverage, we will send you a detailed letter of explanation. We also will charge you for the replacement item plus shipping and handling if you do not return the original item within 10 days of the receipt of the replacement item.

### **Instructions for returning the original item**

1. Please use the return label that is included in the box containing the replacement part. The return shipment address is:

Big Ass Fan Company  
ATTN: RMA# \_\_\_\_\_  
800 Winchester Road  
Lexington, KY 40505

2. Use the packaging for the replacement part to return the original part.
3. Include the packing list we have provided which includes the RMA#.
4. If the part weighs over 50 lbs., you will be provided a prepaid Bill Of Lading. To schedule a freight pick up, please contact Customer Service. We will only charge back the freight costs if the original part is not under warranty, or if you do not return the original component within 10 days of receipt of the replacement.
5. If the part weighs 50 lbs. or less, please use the provided prepaid UPS Ground shipping label and drop off at your nearest UPS pickup location.

If you have questions, please contact us at 1-877-BIG-FANS.



## Warranty claim form instructions

---

1. Complete Warranty Claim Form and Responsibility Agreement and fax them to 859-967-1695, Attn: Customer Service. These pages will be faxed back to you for your records. The Warranty Claim Form will include our acknowledgment and a Return Materials Authorization (RMA) number. **Do not return any item without first being assigned an RMA# by Big Ass Fans Customer Service.**
2. No more than 10 days prior to the date you have made arrangements to replace the component part, call Customer Service at 1-877-BIG-FANS to arrange for replacement component delivery and original component pickup. At that time, we will fax you a written acknowledgment of your call that includes a reminder of the return instructions. Note: Even if you are not able to replace the component immediately following your initial notice to us, returning the Warranty Claim Form and Responsibility Agreement will effectively stop the warranty clock from running. You can then make the product exchange when you are prepared to do so. However, the warranty period will continue to run until we receive these completed pages back from you, and no warranty will be honored without receipt of these pages within the warranty period. We will not send out any replacement part until you have called to let us know that you have scheduled installation of the replacement. This ensures that the replacement part is not lost or damaged while awaiting installation, and that you are not billed for the replacement because you have waited too long to return the original component (see Responsibility Agreement).
3. When you receive the replacement part, you have 10 working days to remove and replace the existing component and return it to us at **800 Winchester Road, Lexington, KY 40505**.
  - a. Upon receiving the replacement part, verify that replacement part order is correct. If order is incorrect or damaged, notify Big Ass Fan Company within 24 hours after receiving order.
  - b. Use care unpacking the replacement component, as you will need to use *both* the packaging from the replacement part and the packing list and a return address label included inside this packaging to return the original part. If the original packaging and return documents are not used, you will be responsible for any damage incurred in transit as well as any additional costs involved. **Note: The RMA# must appear on the outside of the box being returned. Items without an RMA# will not be accepted.**
  - c. Use the delivery service or one of the truck lines specified in the acknowledgement for return of the part. We will refuse receipt of any shipment that is returned via an unauthorized carrier. If you prefer, we can make all arrangements for delivery and pickup.
  - d. Fax a copy of the bill of lading or other tracking information to 859-967-1695 when the item has been shipped so that we know to expect delivery of the original part.
4. If we do not receive the original part back within 15 working days from the date you receive delivery of the replacement, you will be invoiced for the cost of the replacement part, plus freight, on Net 15 terms (see Responsibility Agreement), and this invoice will be due and payable. If you subsequently return the replacement part to us after payment has been made, we will refund any payment made for the replacement part, unless we subsequently determine that the part is not covered under warranty.





800 Winchester Road  
Lexington, KY 40505  
Phone: 1-877-BIG-FANS  
Fax: (859) 967-1695  
www.bigassfans.com

# Warranty Claim Form

Name (print): \_\_\_\_\_ Signature: \_\_\_\_\_

Company: \_\_\_\_\_

Shipping Address: \_\_\_\_\_

City/State/ZIP: \_\_\_\_\_

Phone: \_\_\_\_\_ Fax: \_\_\_\_\_

Items Returned: \_\_\_\_\_ Date of Purchase: \_\_\_\_\_

**Reason(s) for Returning Item** (please provide detail, including length of time after fan had been in operation that problem was noticed, nature of problem, any attempts you made to remedy the problem, etc.):

**ATTENTION: Do not return any item without first being assigned an RMA# by Big Ass Fan Company Customer Service Department. The RMA# must appear on the outside of the box being returned. Items without an RMA# will not be accepted.**

**Date Replacement Parts Should Be Shipped (if known):** \_\_\_\_\_ (Please do not request shipment until you are prepared to install. Call us at 1-877-BIG-FANS to arrange shipment when you have scheduled installation.)

**Acknowledgment of Receipt of Warranty Return Notification**  
(to be completed by Big Ass Fan Company)

**Acknowledged By:** \_\_\_\_\_ **Date:** \_\_\_\_\_

**RMA#:** \_\_\_\_\_

**Authorized Truck Line(s):** \_\_\_\_\_



800 Winchester Road  
Lexington, KY 40505  
Phone: 1-877-BIG-FANS  
Fax: (859) 967-1695  
www.bigassfans.com

# Responsibility Agreement

To: Big Ass Fan Company

The undersigned understands and acknowledges receipt of the Warranty Claim Form and Instructions and agrees that Big Ass Fans ("Big Ass Fan Company") has the right, upon receipt of returned merchandise, to make final determination as to whether this merchandise should be replaced at no cost under Big Ass Fan Company's stated warranty policy.

The undersigned further agrees that if Big Ass Fan Company determines that this merchandise does not qualify under its stated warranty policy, Big Ass Fan Company can invoice for the replacement merchandise plus shipping and handling for the original part and all replacements, and such invoice will be paid within 15 days of receipt of the same.

The undersigned agrees to ship to Big Ass Fan Company's location at 800 Winchester Road, Lexington, KY 40505 all of the merchandise replaced by Big Ass Fan Company including, but not limited to, defective or failed components, within 10 working days of the receipt of the any replacements.

The undersigned further agrees that if said replaced merchandise has not been shipped to Big Ass Fan Company within 10 working days, Big Ass Fan Company can invoice for the replacement merchandise plus shipping and handling, and the invoice will be paid within 15 days of receipt.

**Signed:** \_\_\_\_\_

**Title:** \_\_\_\_\_

**For:** \_\_\_\_\_  
(Name of Company)

**Date:** \_\_\_\_\_



2348 Innovation Drive  
Lexington, KY 40511  
Phone: 1-859-233-1271  
www.bigasssolutions.com

# Check-In Procedure

(for Big Ass Fans Certified Installers Only)

**ATTENTION: These items must be completed prior to any additional installation crew members entering jobsite or any installation material being unloaded.**

Date: \_\_\_\_\_

Company: \_\_\_\_\_ Job Name: \_\_\_\_\_

Address: \_\_\_\_\_ Purchase Order No.: \_\_\_\_\_

City/State/ZIP: \_\_\_\_\_

Contact Name: \_\_\_\_\_ Phone: \_\_\_\_\_

E-mail: \_\_\_\_\_

**\*\*SEE THE FOLLOWING PAGE FOR NFPA 13 REGULATIONS\*\***

<input type="checkbox"/>	Fan placement is to be in accordance with agreed upon original Scope of Work and Layout. If this is to change, please note change and consult Field Service Manager for approval.
<input type="checkbox"/>	Installation techniques have been discussed (type of conduit, L-brackets if required, mounting technique explained). If the extension tubes exceed 4 ft (1.2 m), guy wires are explained and fully understood.
<input type="checkbox"/>	Times in/out, duration, and schedule presented and accepted.
<input type="checkbox"/>	Time (please list the number of employees and total duration of jobs):  
<input type="checkbox"/>	Safety rules and regulations have been brought to installer's attention (e.g., badges, safety harnesses, vests, hard hats, footwear, lock out/tag out, certification processes, work area free of trash and debris, etc.). If there are any areas that are forbidden or secure, they are brought to the supervisor's attention and instructed not to enter. If there are any special site conditions (i.e., open areas and operating machinery to be avoided), they are also brought to the supervisor's attention and instructed how to bypass the area if required. Safety Rules and Regulations listed:  
<input type="checkbox"/>	The facility manager understands all electrical requirements, i.e., breaker size, voltage, brand, main panel space, and they are in accordance with original Scope of Work and Layout.
	Additional comments:  

# Check-In Procedure (cont.)

(for Big Ass Fans Certified Installers Only)

---

---

## National Fire Protection Association Standard

In accordance with NFPA 13 Standard from the National Fire Prevention Association as referenced in sections 12.1.4 and 11.1.7: High Volume Low Speed (HVLS) Fans:

The installation of HVLS fans in buildings equipped with sprinklers, including ESFR sprinklers, shall comply with the following:

- The maximum fan diameter shall be 24 feet (7.3 m).
- The fan shall be approximately centered between four adjacent sprinklers.
- The vertical clearance from the fan to sprinkler deflector shall be a minimum of 3 feet (0.9 m).
- All fans shall be interlocked to shut down immediately upon receiving a water flow signal from the alarm system in accordance with the requirements of NFPA 72- National Fire Alarm and Signaling Code.

**WARNING: The fan should not be installed unless the structure on which the fan is to be mounted is of sound construction, undamaged, and capable of supporting the loads of the fan and its method of mounting. Verifying the stability of the mounting structure is the sole responsibility of the customer and/or end user, and Big Ass Fans hereby expressly disclaims any liability arising therefrom, or arising from the use of any materials or hardware other than those supplied by Big Ass Fans or otherwise specified in the installation instructions.**

If this installation will be performed outside the scope of work or not within the specifications of Big Ass Fans by customer's request, please provide specific details:

---

---

---

---

Please sign below if both parties agree that all aspects of this installation have been thoroughly explained and are of clear understanding and agreement of the installation to be completed.

**Customer Signature:** \_\_\_\_\_

**Printed Name:** \_\_\_\_\_ **Date:** \_\_\_\_\_

**Contractor Signature:** \_\_\_\_\_

**Printed Name:** \_\_\_\_\_ **Date:** \_\_\_\_\_

The supervisor is to hold all documents until the job is complete and send all forms back to Field Service Manager. This will consist of the service/work order, Check-In document, and Close-Out document. The installation crew will not receive payment until all forms are signed by the facility manager and the supervisor. These documents will then be forwarded to the Field Service Manager at Big Ass Fans.



2348 Innovation Drive  
Lexington, KY 40511  
Phone: 1-859-233-1271  
www.bigasssolutions.com

# Close-Out Procedure

(for Big Ass Fans Certified Installers Only)

Date: \_\_\_\_\_

Company: \_\_\_\_\_ Job Name: \_\_\_\_\_

Address: \_\_\_\_\_ Purchase Order No.: \_\_\_\_\_

City/State/ZIP: \_\_\_\_\_

Contact Name: \_\_\_\_\_ Phone: \_\_\_\_\_

E-mail: \_\_\_\_\_

**\*\*SEE THE FOLLOWING PAGE FOR NFPA 13 REGULATIONS\*\***

**The field crew supervisor and facility manager are to walk through the completed installation.**

<input type="checkbox"/>	The installation is complete and on time in accordance with the original Check-In document. If not, explain:
<input type="checkbox"/>	Conduit runs are installed in accordance with the Check-In document, Scope of Work, and Layout. If not, explain:
<input type="checkbox"/>	The fans are correctly placed in accordance with both the Check-In document, Scope of Work, and Layout. If not, explain:
<input type="checkbox"/>	Breaker size and wire type are in accordance with the Check-In document, Scope of Work, and Layout. If not, explain:
<input type="checkbox"/>	All safety rules and regulations met in accordance with the Check-In document, Scope of Work, and Layout. If not, explain:
<input type="checkbox"/>	Fans have been running for over an hour and operate without visible defect or issue.
<input type="checkbox"/>	The fan is spinning in the correct direction (counterclockwise when viewed from floor).
<input type="checkbox"/>	Angle irons are securely fastened and are without any apparent problems in accordance with installation techniques discussed at check-in.
<input type="checkbox"/>	If extension tube is 4 ft (1.2 m) or longer, guy wires are in place and there is no evidence of a wobble.
<input type="checkbox"/>	Supervisor or contractor has supplied and explained the Installation Guide. If not, explain:
<input type="checkbox"/>	The supervisor or contractor has explained and I understand how to operate fan including starting/stopping, speed operation, and power disconnect. If not, explain:
<input type="checkbox"/>	Time in/out and duration are in accordance with Check-In document.
	Additional comments:

# Close-Out Procedure (cont.)

(for Big Ass Fans Certified Installers Only)

---

---

## National Fire Protection Association Standard

In accordance with NFPA 13 Standard from the National Fire Prevention Association as referenced in sections 12.1.4 and 11.1.7: High Volume Low Speed (HVLS) Fans:

The installation of HVLS fans in buildings equipped with sprinklers, including ESFR sprinklers, shall comply with the following:

- The maximum fan diameter shall be 24 feet (7.3 m).
- The fan shall be approximately centered between four adjacent sprinklers.
- The vertical clearance from the fan to sprinkler deflector shall be a minimum of 3 feet (0.9 m).
- All fans shall be interlocked to shut down immediately upon receiving a water flow signal from the alarm system in accordance with the requirements of NFPA 72- National Fire Alarm and Signaling Code.

**WARNING: The fan should not be installed unless the structure on which the fan is to be mounted is of sound construction, undamaged, and capable of supporting the loads of the fan and its method of mounting. Verifying the stability of the mounting structure is the sole responsibility of the customer and/or end user, and Big Ass Fans hereby expressly disclaims any liability arising therefrom, or arising from the use of any materials or hardware other than those supplied by Big Ass Fans or otherwise specified in the installation instructions.**

**NOTE: The customer's initials are required as acknowledgement for the following instances:**

- \_\_\_ Return Trip Required – Additional Charges Apply (Customer not Ready/Lift Issues)
- \_\_\_ Work Completed Outside Scope of Work (if applicable)
- \_\_\_ Installation Not Performed Per BAF Recommendations or Specifications For Any Reason
- \_\_\_ Customer Understands and Approves Additional Charges As Explained in amount of \$\_\_\_\_\_ (if applicable)
- \_\_\_ Other (Please Explain Below)

If any portion of this installation was performed outside the scope of work or not within the specifications of Big Ass Fans at any capacity or for any reason, please provide specific details below:

---

---

---

---

---

Signatures of both parties are required below to acknowledge that this installation has been completed to customer's satisfaction, to activate fan(s) warranty, and to issue payment to contractor (with required documentation):

**Customer Signature:** \_\_\_\_\_

**Printed Name:** \_\_\_\_\_ **Date:** \_\_\_\_\_

**Contractor Signature:** \_\_\_\_\_

**Printed Name:** \_\_\_\_\_ **Date:** \_\_\_\_\_

The supervisor is to hold all documents until the job is complete and send all forms back to Field Service Manager. This will consist of the service/work order, Check-In document, and Close-Out document. The installation crew will not receive payment until all forms are signed by the facility manager and the supervisor. These documents will then be forwarded to the Field Service Manager at Big Ass Fans.









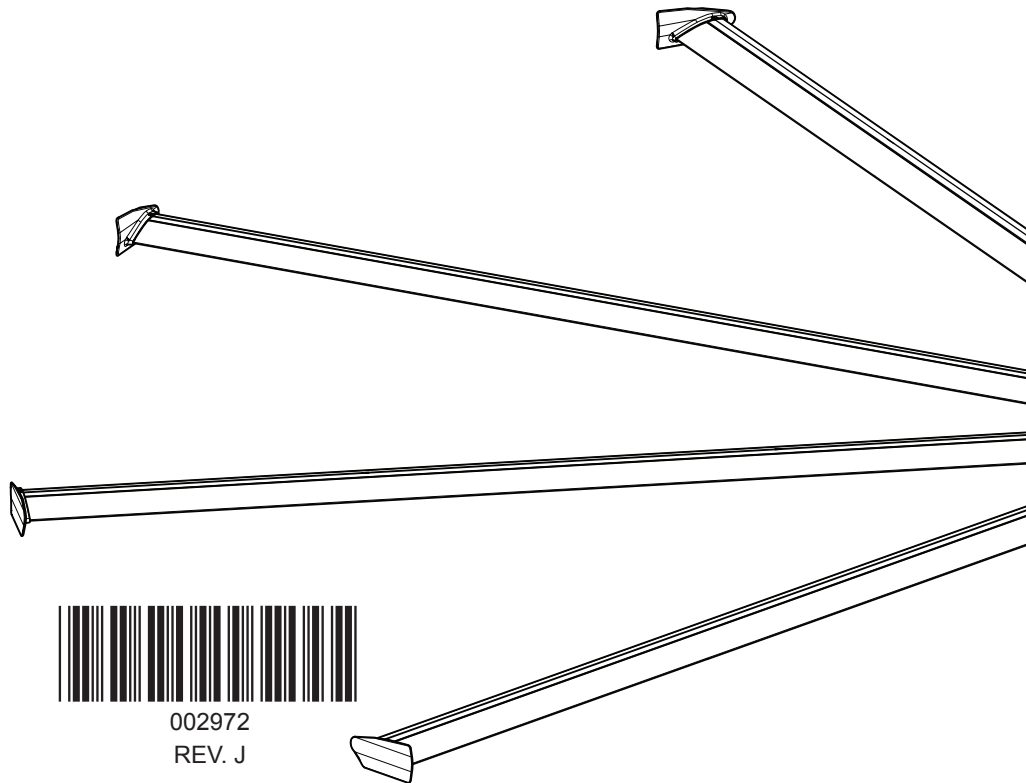

002972  
REV. J



**BIGASS**<sup>®</sup>  
FANS

2425 Merchant St., Lexington, KY 40511  
1 (877) BIG-FANS | [WWW.BIGASSFANS.COM](http://WWW.BIGASSFANS.COM)