



Date: October 4, 2010

To: Mark Cotter, Director of Public Works
Mike Cooper, Director of Planning and Building Services
Jeff Schmitt, Assistant Director of Planning and Building Services
Steve Van Buskirk, VanBuskirk Companies, Incorporated
Preston Mettler, Mettler Construction
Matt Carlson, Carl V. Carlson Company
Scott Hofer, Hanson Pipe and Precast
Steve Brockmueller, Heartland Engineering
Myron Adam, JSA Engineering
Tim Galbraith, MidAmerican Energy
Bill Kemmis, Midcontinent Communications
Mark Vellinga, Graham Organization
Pat Beckman, Beckman Realty & Development

From: Chad J. Huwe, City Engineer

Subject: INFRASTRUCTURE REVIEW ADVISORY BOARD (IRAB) MEETING

IRAB will meet on Wednesday, October 6, 2010 at 8:30 a.m., at the Oak View Library, 3700 East 3rd Street.

AGENDA

1. Approval of Minutes from August 18, 2010
2. Business
 - a. 2010 Standard plates and specification changes for IRAB (*Dallas Hofer*)
 - b. USPS – Mail box requirements (*Rickie Kuezweiler, Postmaster USPS, and Scott Eichenauer, Supervisor Customer Services*)
 - c. Subdivision Update (*Shannon VerHey*)
 - d. Sump Pump Ordinance update (*Andy Berg, Mark Perry*)

cc: Mayor Huether
Clerk of Records
Julie Terrell, Home Builders Association

NOTE: If you or your alternate are unable to attend this meeting, please call Betsy Odden at 367-8664 or e-mail at bodden@siouxfalls.org as soon as possible.

ROADSIDE SINGLE SIGN

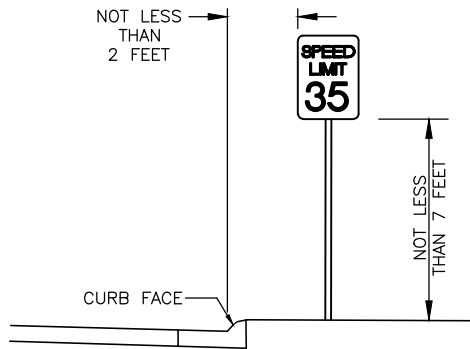

STREET LIGHT/WOODEN POWER POLE MOUNT

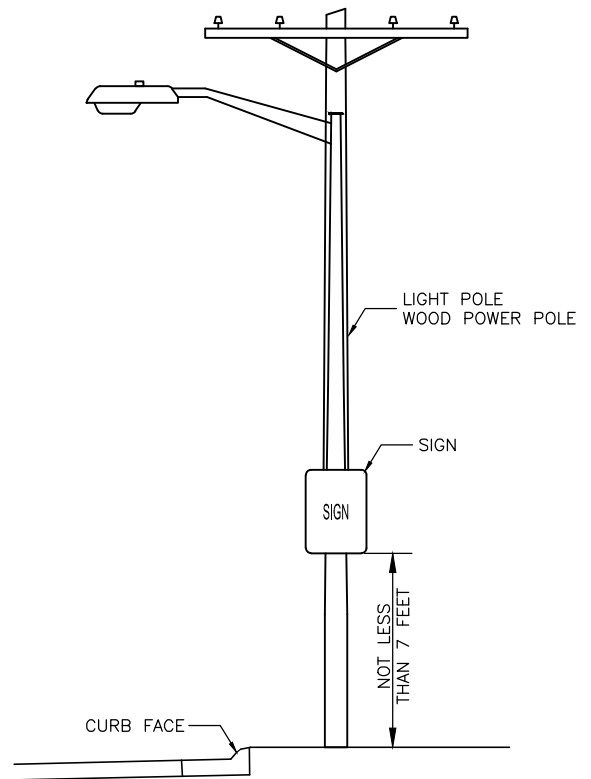

ROADSIDE MULTIPLE SIGN

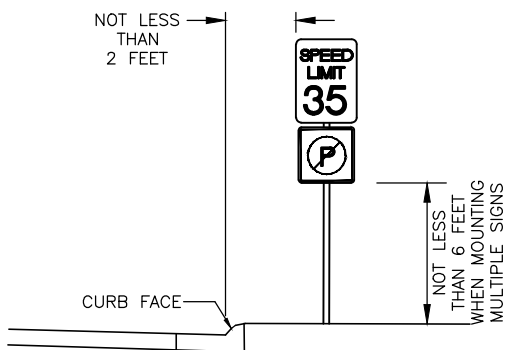

STOP/STREET NAME SIGNS

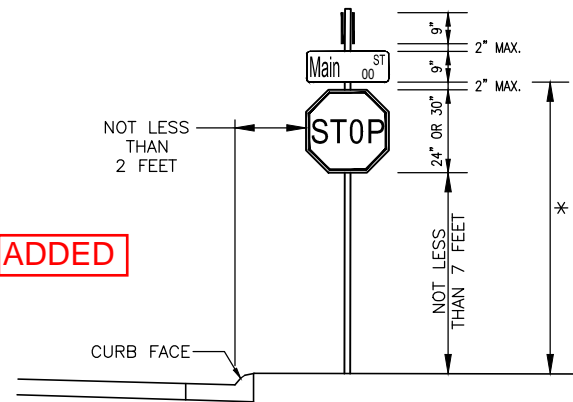

ADDED

* 10' WHEN STREET NAME SIGNS ARE MOUNTED ALONE ON POST.

SIGN ON NOSE OF MEDIAN

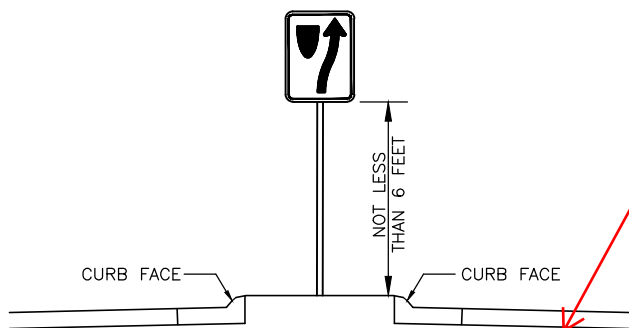

NOTE: ALL R7 & R8 SERIES SIGNS WITH ARROWS SHALL BE INSTALLED AT A 45 DEGREE ANGLE TO THE STREET.

REVISED: SEPTEMBER 2010

SPECIFICATION
REFERENCE
NO.
632



CITY OF SIOUX FALLS
ENGINEERING DIVISION
HEIGHTS AND LATERAL LOCATIONS OF
SIGNS FOR TYPICAL URBAN INSTALLATION

PLATE
NUMBER
632.10

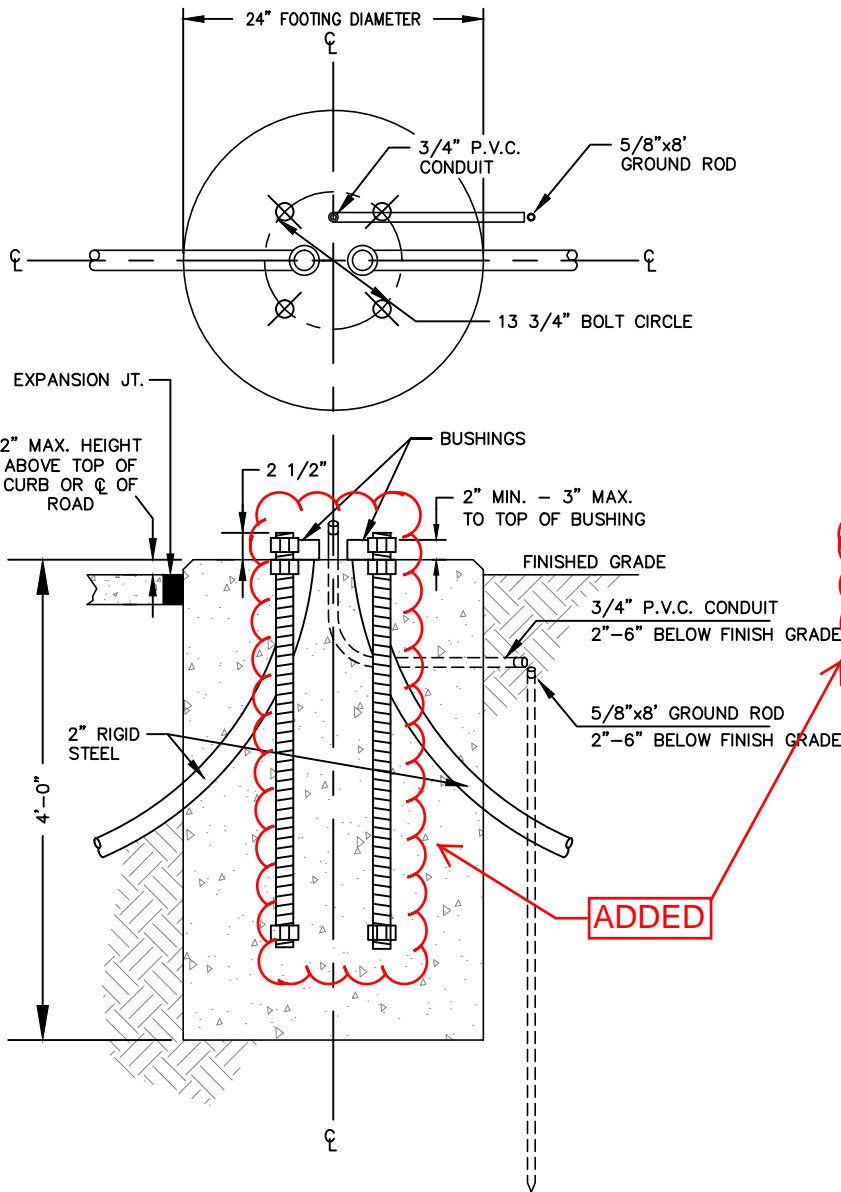

GENERAL NOTES:

EXPANSION JOINT MATERIAL - A TWO-INCH (2") EXPANSION STRIP, ASPHALT CONCRETE TYPE "E", COMPACTED AS DIRECTED BY THE ENGINEER, SHALL ISOLATE FOOTING FROM OTHER CONCRETE. COST OF EXPANSION STRIP TO BE INCLUDED IN THE BID PRICE FOR FOOTINGS.

CONDUITS SHALL BE SEALED, WATER-TIGHT DURING ALL PHASES OF CONSTRUCTION UNTIL POLES ARE IN PLACE

THE CONTRACTOR IS RESPONSIBLE FOR SUPPLYING THE ANCHOR BOLTS. **CHANCE #8816, OR EQUIVALENT (5/8"x16")** COST OF THE RGSC AND CONDUIT BUSHING SHOWN IN FOOTINGS DETAIL TO BE INCLUDED IN THE BID PRICE FOR FOOTINGS.

ALL CONCRETE SHALL BE CLASS M-6

USE CURRENT SOUTH DAKOTA STANDARD SPECIFICATIONS FOR ROADS AND BRIDGES.

IF INSTALLED, ALL REINFORCING STEEL SHALL CONFORM TO A.S.T.M. A-615, GRADE 40.

CAP ALL UNUSED CONDUIT.

FINISHED BASE WILL BE LEVEL AND HAVE STEEL TOWEL FINISH.

ADDED

REVISED: SEPTEMBER 2010

SPECIFICATION
REFERENCE
NO.
635A



CITY OF SIOUX FALLS
ENGINEERING DIVISION
SIGNAL FOOTING
FOR PEDESTAL SIGNAL

PLATE
NUMBER
635.13

NOTES

THE PERMANENT TRAFFIC COUNTER SURFACE UTILITY BOX SHALL BE EMERSON NETWORK POWER - UPCBD3 OR APPROVED EQUAL.

BOLT BOX TO TELES PAR POST WITH A MINIMUM OF TWO (2) BOLTS.

* BOX OPENING TO FACE AWAY FROM STREET.

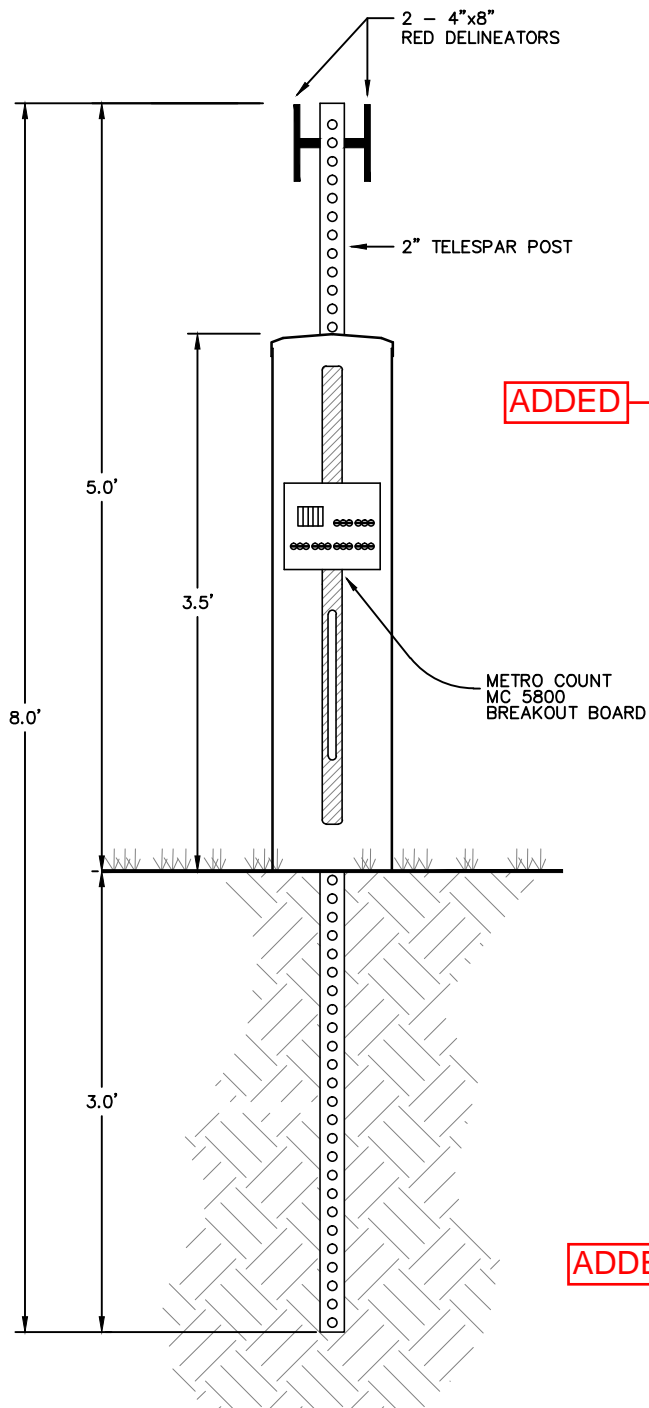

ADDED

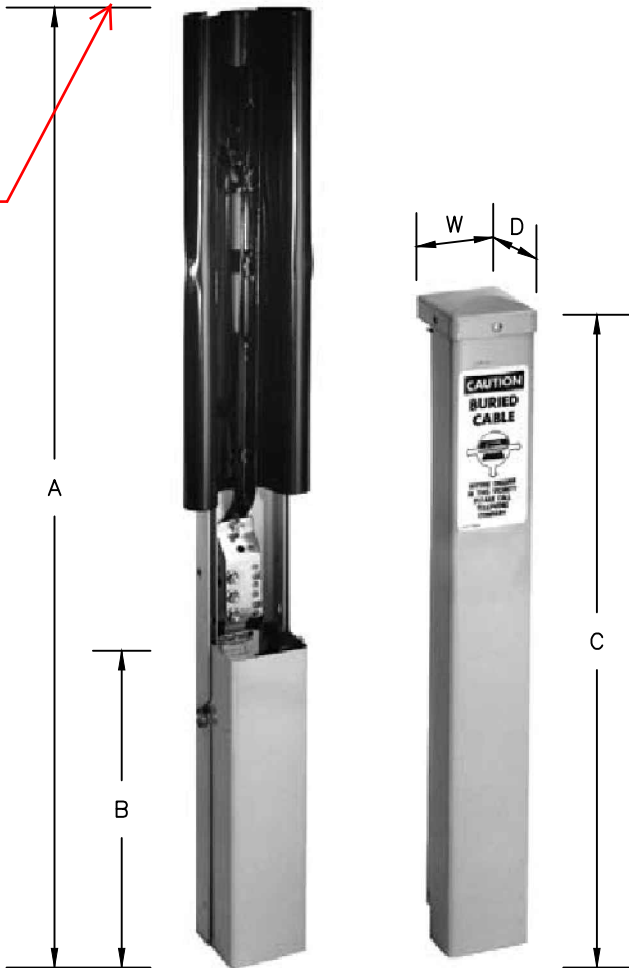

ADDED

Dimensions (Inches)				
A	B	C	D	W
36.5	12	24.5	6	6

REVISED: SEPTEMBER 2010

SPECIFICATION
REFERENCE
NO.
635A



CITY OF SIOUX FALLS
ENGINEERING DIVISION
PERMANENT TRAFFIC COUNTER
SURFACE UTILITY BOX

PLATE
NUMBER
635.25

CAST IRON COVER

18" JB - NEENAH FOUNDRY CO. R-5900-C SERIES
OR ENGINEER APPROVED.

24" JB - NEENAH FOUNDRY CO. R-5900-E SERIES
OR ENGINEER APPROVED.

30" JB - NEENAH FOUNDRY CO. R-5900-G SERIES
OR ENGINEER APPROVED.

NOTES:

ALLOW SUFFICIENT SLACK SO THAT CABLE ENDS
CAN BE PULLED TO 30" ABOVE JUNCTION BOX.

NUMBER OF CONDUIT ENTRANCES VARIES WITH
LOCATION OF JUNCTION BOX.

ANCHOR FRAME TO PIPE AS APPROVED BY THE ENGINEER.

COVER SHALL BE STAMPED TRAFFIC.

THE ENDS OF THE INNERDUCT CONDUIT IN THE JUNCTION
BOX SHALL BE SEALED WITH A WATER PROOF SEALANT
TO PREVENT WATER INFILTRATION INTO THE CONDUIT.

SLOTS CUT IN CULVERT MUST BE REPAIRED.

THE JUNCTION BOX SIZES AND QUANTITIES ARE SHOWN
ON THE PLAN SHEETS.

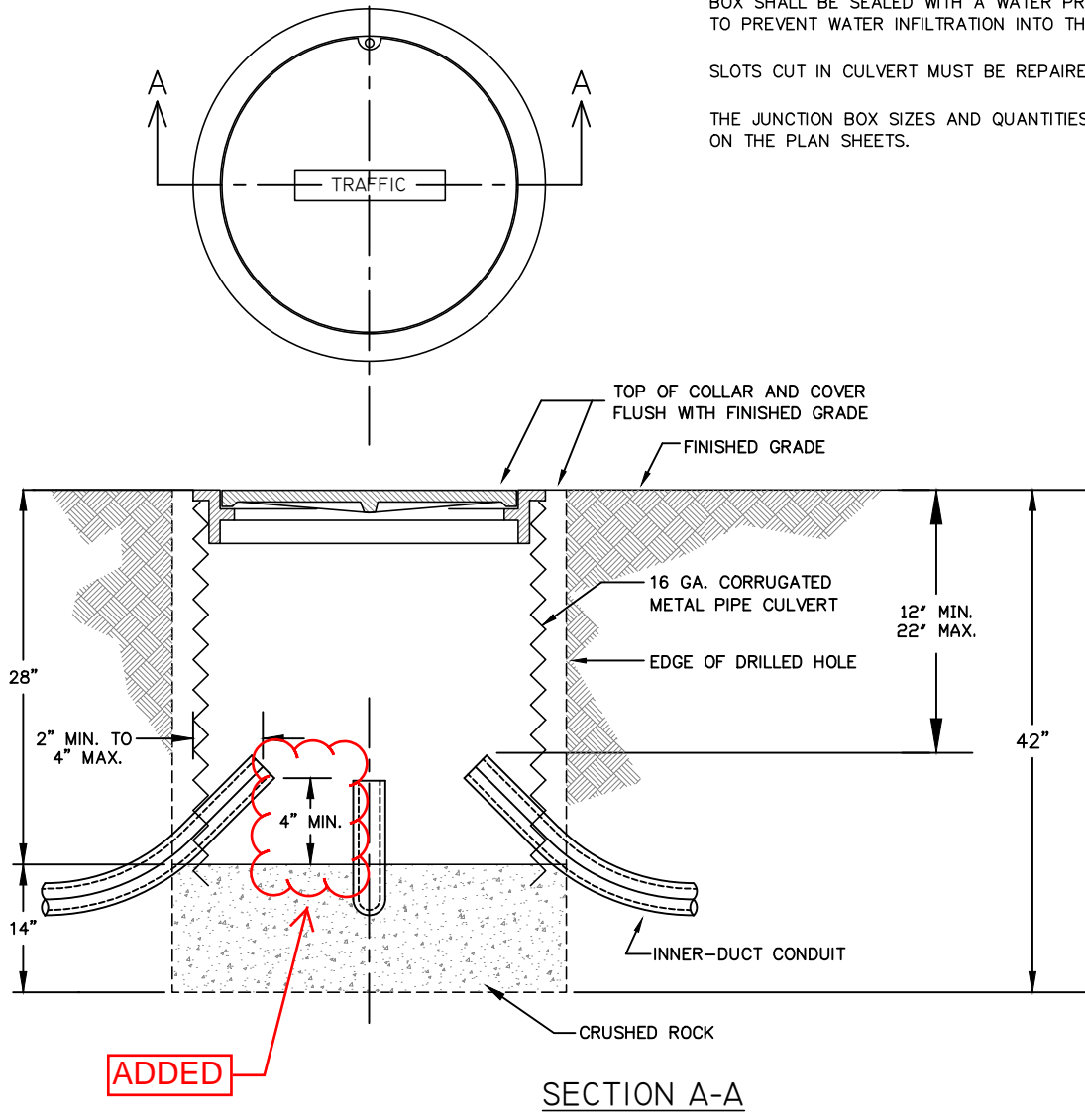

SECTION A-A

REVISED: SEPTEMBER 2010

SPECIFICATION
REFERENCE
NO.
635A



CITY OF SIOUX FALLS
ENGINEERING DIVISION
JUNCTION BOX - INNERDUCTS

PLATE
NUMBER
635.33

9" STREET NAME SIGN

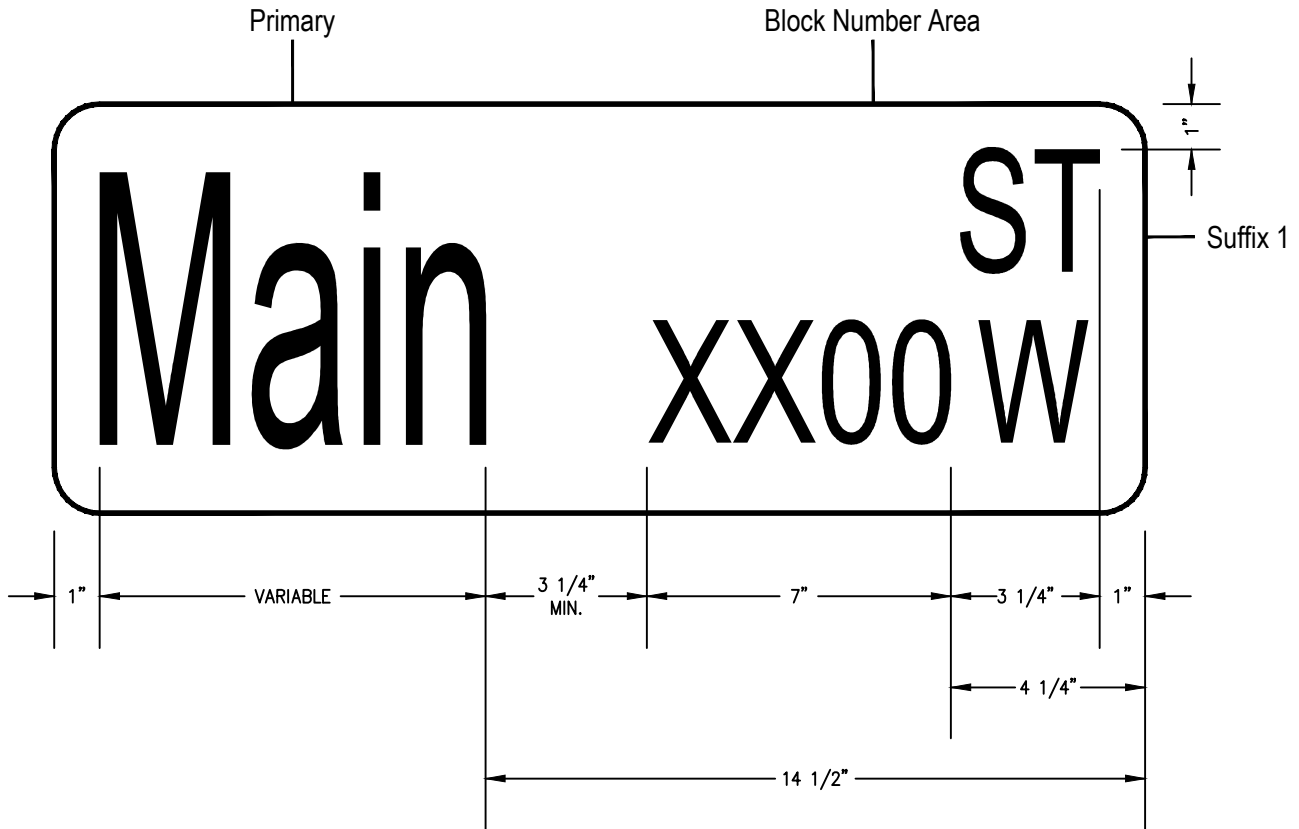

PRIMARY:

6 INCH UPPER CASE AND 4 1/2 INCH LOWER CASE
(TO BE PUT ON BY SUPPLIER AND CENTERED IN
SPACE WITH NO MORE THAN 80% COMPRESSION)

SUFFIX 1:

3 INCH CAPITAL LETTERS (TO BE PUT ON BY SUPPLIER)

BLOCK NUMBER AREA:

TO BE PUT ON BY SUPPLIER/CONTRACTOR

REVISED: SEPTEMBER 2010

SPECIFICATION
REFERENCE
NO.
632



CITY OF SIOUX FALLS
ENGINEERING DIVISION
9" STREET NAME SIGN

PLATE
NUMBER
632.30

18" MAST ARM FACE SIGN

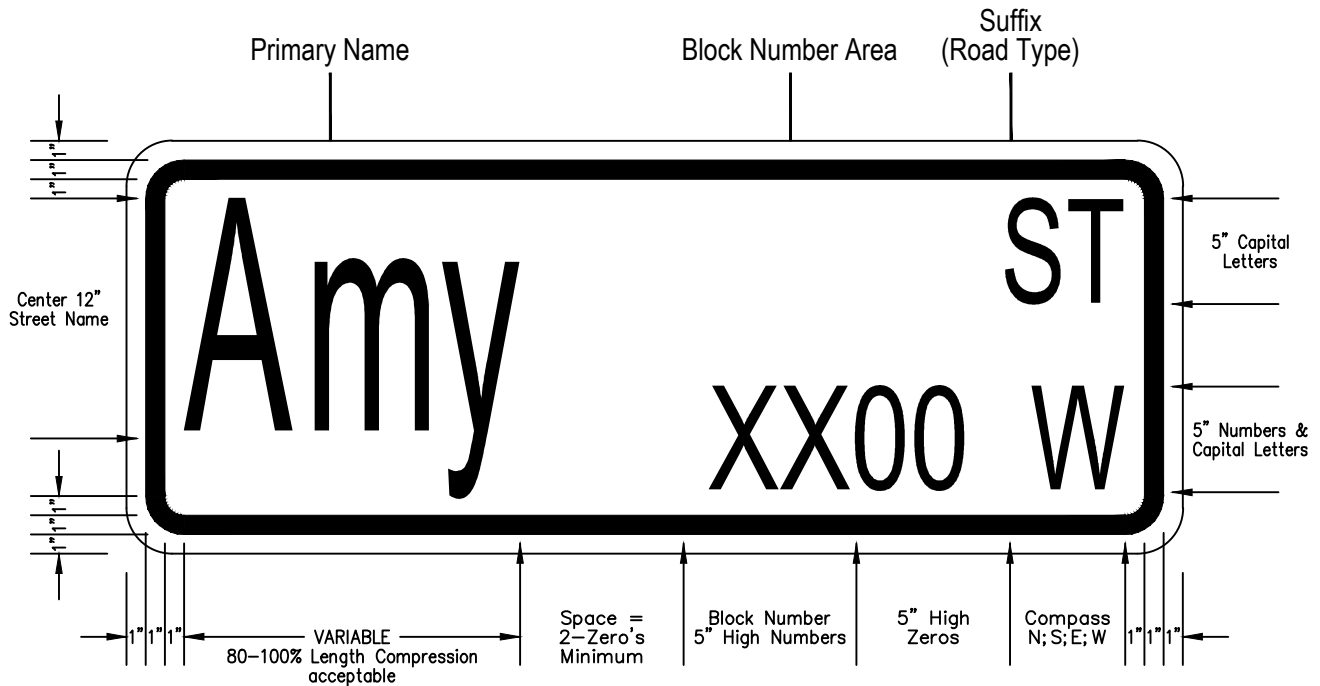

PRIMARY NAME:

12 INCH HIGH UPPER CASE; 9 INCH LOWER CASE; WHITE LETTERS WILL BE PUT ON BY SUPPLIER. HEIGHT DIMENSION IS NOT COMPRESSIBLE.

SUFFIX (ROAD TYPE):

5 INCH HIGH; ALL WHITE CAPITAL LETTERS; INSET FROM WHITE BORDER 1 INCH FROM TOP SIDE, RIGHT SIDE. TO BE PUT ON BY SUPPLIER.

BLOCK NUMBER AREA; SPACE; COMPASS DIRECTOR:

"00" OR ENTIRE BLOCK ADDRESS NUMBER WITH COMPASS DIRECTOR WILL BE PUT ON PER CITY OF SIOUX FALLS ORDER SPECIFICATION; BY SUPPLIER. INSET FROM WHITE BORDER 1 INCH FROM BOTTOM SIDE, RIGHT SIDE. 5 INCH HIGH LETTERING/ NUMBERS ALL CAPITALS.

* MAST ARM SIGN HAS (WHITE 1-INCH-BORDER; WHITE LETTERING & NUMBERING) ON GREEN BACKGROUND.

REVISED: SEPTEMBER 2010

SPECIFICATION
REFERENCE
NO.
632



CITY OF SIOUX FALLS
ENGINEERING DIVISION
18" MAST ARM FACE SIGN

PLATE
NUMBER
632.31

12.0 S.F.

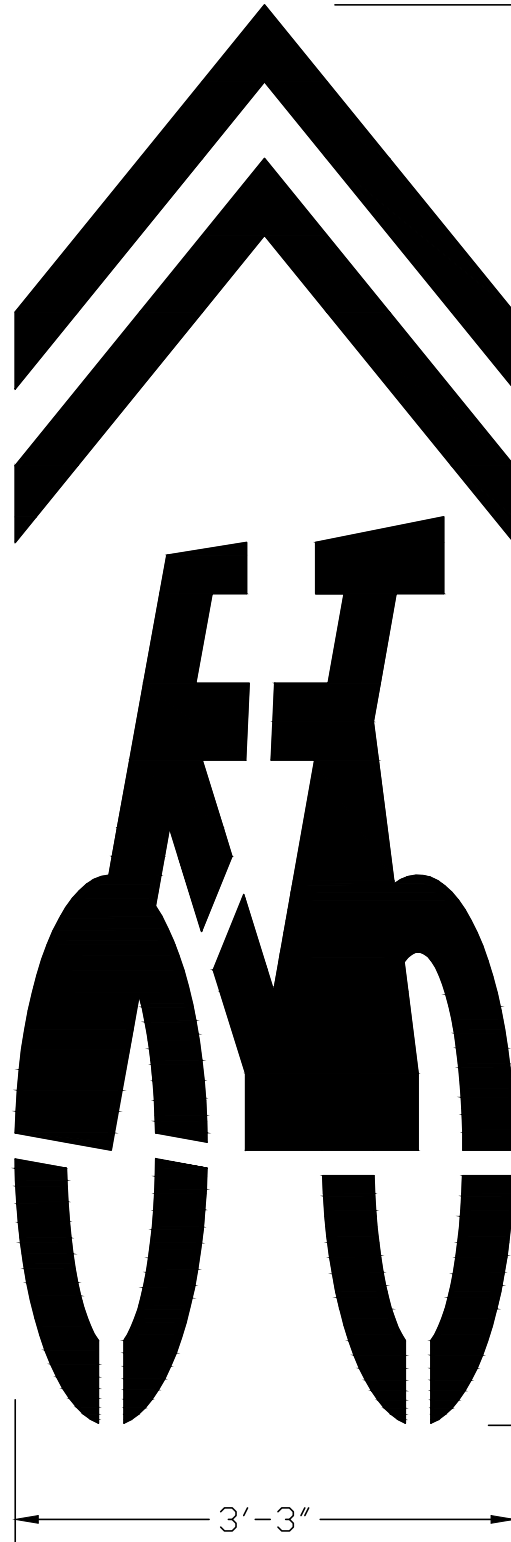

9'-3"

3'-3"

REVISED: SEPTEMBER 2010

SPECIFICATION
REFERENCE
NO.
633



CITY OF SIOUX FALLS
ENGINEERING DIVISION
SHARROW STRIPING DETAIL

PLATE
NUMBER
633.30

16.4 S.F.

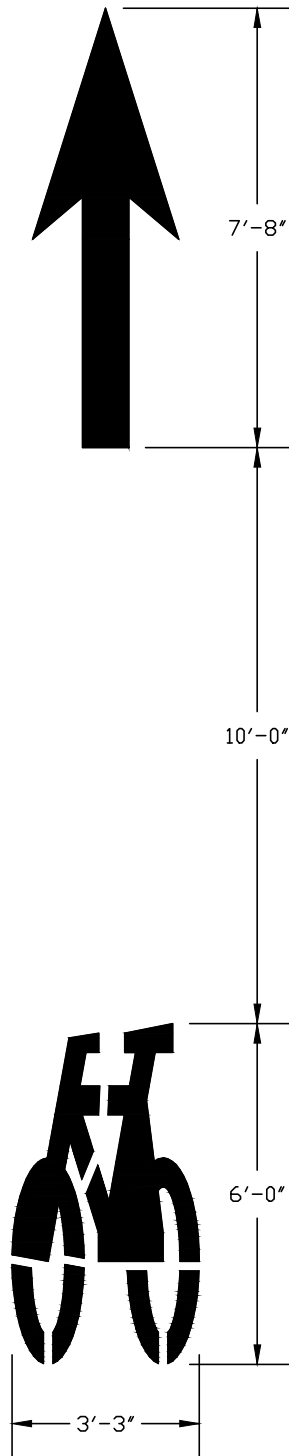

REVISED: SEPTEMBER 2010

SPECIFICATION
REFERENCE
NO.
633



CITY OF SIOUX FALLS
ENGINEERING DIVISION
BICYCLE STRIPING DETAIL

PLATE
NUMBER
633.40

TRAFFIC CONTROL

(Typical Lane Closure)

TAPER FORMULA:

$L = S \times W$ FOR SPEEDS OF 45 OR MORE.

$L = WS^2/60$ FOR SPEEDS OF 40 OR LESS.

WHERE:

- L = MINIMUM LENGTH OF TAPER
- S = NUMERICAL VALUE OF POSTED SPEED LIMIT PRIOR TO WORK OR 85TH PERCENTILE SPEED.
- W = WIDTH OF OFFSET.

□ CHANNELIZING DEVICES

∞ ARROW PANEL

△ SPACING BETWEEN DEVICES SHALL BE UP TO 2 TIMES THE NUMERICAL VALUE OF THE POSTED SPEED LIMIT PRIOR TO WORK.

NOTE:

THE MAXIMUM SPACING BETWEEN CHANNELIZING DEVICES IN A TAPER SHALL BE APPROXIMATELY EQUAL IN FEET TO THE SPEED LIMIT.

IF THE ROAD HAS AN AADT OF LESS THAN 20,000, THE CLOSURE IS NOT IN PLACE OVERNIGHT, AND THE SPEED IS LESS THAN 40 MPH, THE W20-5 SIGN IS OPTIONAL.

POSTED SPEED PRIOR TO WORK (M.P.H.)	SPACING OF ADVANCE WARNING SIGNS (FEET)			TAPER LENGTH (FEET) (L)
	(A)	(B)	(C)	
0 - 25	100 - 200			$\frac{W \cdot S^2}{60}$
30	120 - 240			$\frac{W \cdot S^2}{60}$
35	140 - 280			$\frac{W \cdot S^2}{60}$
40	160 - 320			$\frac{W \cdot S^2}{60}$
45	180 - 360			$W \cdot S$
50	200 - 400			$W \cdot S$
55	220 - 440			$W \cdot S$

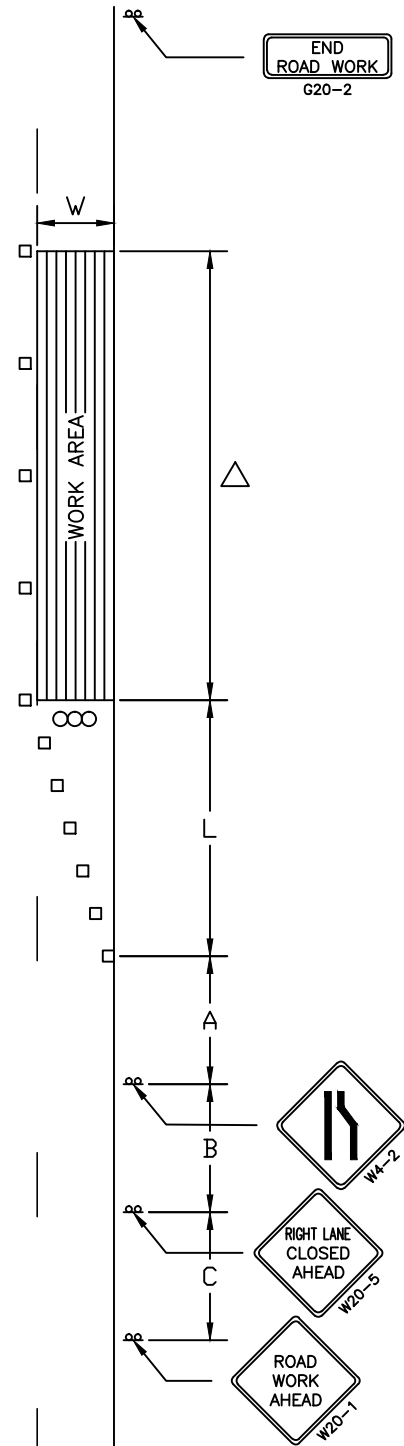

REVISED: SEPTEMBER 2010

SPECIFICATION
REFERENCE
NO.
634



CITY OF SIOUX FALLS
ENGINEERING DIVISION
TYPICAL APPLICATION - CONSTRUCTION OPERATIONS
TYPICAL LANE CLOSURE

PLATE
NUMBER
634.01

632.1 DESCRIPTION

This work consists of furnishing materials, making and preparing traffic signs and delineators, and performing incidental work, including erection and installation of signs, hardware, and posts.

632.2 MATERIALS

A. Traffic Signs

- 1. Sheet Aluminum:** Sheet aluminum shall meet the requirements of ASTM B 209 for alloy 5052-H38 or 6061-T6. The aluminum shall be properly degreased and etched or treated with a light, tight, amorphous chromate coating. Sheet aluminum thickness requirements shall be based on the maximum horizontal in place dimension of each sheet aluminum sign in accordance with the following:

HORIZONTAL DIMENSION OF IN PLACE SIGN BLANK	REQUIRED SIGN BLANK THICKNESS
(English Units)	
18" and less	0.080"
Over 18" through 30"	0.080"
Over 30"	0.100"
<u>Street Name Signs</u>	<u>0.125"</u>

B. Perforated Tube Posts and Flanged Channel Posts

Post material shall meet impact performance (change in momentum) requirements for small sign supports contained in the current AASHTO "Standard Specifications for Structural Supports for Highway Signs, Luminaries, and Traffic Signals."

Anchor plates for Perforated Tube Posts and Flanged Channel Posts shall be galvanized in accordance with ASTM A123, or painted with a dark green high quality enamel. The steel plates shall be trapezoidal in shape with bases of 6 and 12 inches, a depth of 6 inches, and shall be either 10 gauge, 1/8 inch, or 1/4 inch in thickness. The steel shall meet the requirements of ASTM A36 or ASTM A1011 Structural Steel Grade 36. Bolt holes of 3/8 inch shall be provided centered on the plate with a spacing of 4 inches.

- 1. Perforated Tube Posts:** Perforated tube posts shall conform to ASTM A1011 Structural Steel Grade 50.

Posts shall be a square tube formed of 12 gauge steel, 0.105 inch thick, rolled to size. The tubing shall be molded so the weld or flash does not interfere with telescoping. The posts shall be hot dipped galvanized with a 1.25 ounce per square foot coating conforming to ASTM A653. As an alternate, the post shall be given a triple coated protection by application of hot dip galvanized zinc conforming to ASTM A 53, followed by a chromate conversion coating and a

polyurethane exterior coating, with inside surfaces given corrosion protection by in-line application of zinc base organic coating after fabrication.

The posts shall be punched, bored, or have knockouts with 7/16-inch diameter holes on 1-inch centers of all four sides for the entire length of the posts. The post sections shall be straight, with a smooth uniform finish and a minimum amount of play between telescoping sections. Holes and cutoff ends shall be free of burrs and ragged edges. Bolts, nuts, and washers shall conform to ASTM A 307 and shall be galvanized.

- 2. Flanged Channel Posts:** Posts and bases shall be a flanged channel section fabricated from either hot rolled carbon steel bars or carbon steel bars and shapes produced from standard rail steel. The posts and bases shall meet the minimum physical properties of ASTM A499, Grade 60 except that the minimum yield strength shall be 70,000 psi. The post shall meet chemical properties of ASTM A1 for rails 30 pounds per foot and heavier.

The weight of posts shall be as specified and shall be 2.00 (Post) or 3.00 (Base) pounds per foot plus or minus 5.0 percent before punching. The posts and bases shall be painted with a high quality baked on dark green enamel. All punching, boring, cutting, or shearing shall be performed prior to painting. The posts shall be punched with continuous 3/8-inch diameter holes on 1-inch centers for the entire length of the post. The first hole shall be 1 inch from the top.

The post may consist of two parts, a sign post and a base post. The sign post lengths shall be supplied in 1-foot increments up to 10 feet. The base posts shall be 42 inches in length and have holes in the base post, starting 1 inch from the top and continuing in 1 inch increments.

The posts shall be machine straightened and have a smooth uniform finish, free from defects affecting strength, durability, or appearance. The allowable tolerance for straightness shall be 1/4 inch in 5 feet.

~~Bolts, nuts, washers, and spacers shall be cadmium plated in accordance with ASTM A 165 or zinc plated in accordance with ASTM B 633.~~ The splice hardware shall consist of two fully threaded, 5/16 inch by 1 1/2 inch, Grade 9, plated hex head bolts, with flat washers and hex nuts per post. In addition, two 3/4-inch by 5-inch by 1/2-inch plated spacers shall be used per post to stiffen the splice connection. Each spacer shall be drilled and tapped with 5/16 inch by 18 UNC threads. The spacer shall be fabricated from hot rolled carbon steel bars conforming to ASTM A 36 or AISI M 1020. A Grade G flanged lock nut (5/16-inch, 18 thread) may be substituted for the lock washer and hex nut.

C. Reflective Sheeting:

- 1. Grade:** All Stop Signs, Yield Signs and Street Name Signs shall use DG3 (Diamond Grade Cubed) sheeting material.

All warning signs shall use Florescent DG3 sheeting material.

All school signs shall use Florescent Yellow/Green DG3 sheeting material.

All other signs shall use HIP (High Intensity Prismatic) sheeting material.

2. **General Characteristics:** The reflective sheeting shall be free from ragged edges, cracks, and extraneous materials. There shall be no splices in the reflective sheeting.
3. **Fabrication:** The background for signs shall be sheet reflective material applied to aluminum backing. The preparation of the aluminum surface and the sheeting application shall be in complete compliance with the recommendations of the manufacturer.
4. **Application:** Reflective sheeting shall be applied to properly prepared aluminum (degreased and etched or treated with a light, tight, amorphous chromate coating) with mechanical equipment in a manner prescribed by the sheeting manufacturer.
5. **Legend:** Message and borders shall be type, reflective material, and color specified. Nonremovable copy may be screen processed or direct applied.
 - a. **Nonremovable Copy:** (For use on sheet aluminum signs.)
 - 1) **Screen Process:** Message and borders shall be processed on reflective sheeting using mechanical equipment, materials, and operational methods and procedures as prescribed by the sheeting manufacturer. Processing shall be accomplished by the direct or reverse screen method using opaque or transparent processing material as required. Screening may be accomplished either before or after application of the sheeting to the base panels, conditional upon the method recommended by the sheeting manufacturer. Freehand painting will not be permitted on any part of the finished sign face.
 - 2) **Direct Applied:** Cut-out message and borders shall be reflective sheeting or opaque lettering film applied directly to clean, dust free, reflective sheeting background. Message and borders shall be applied in accordance with the operational methods and procedure prescribed by the sheeting manufacturer. The finished letters, numerals, symbols, and borders shall be cut with smooth regular outline, free from ragged or torn edges.

Mounting holes will not be drilled or punched in any part of the nonremovable copy.
6. **Color:** The reflective sheeting shall meet the color specification limits and luminance factors listed in Tables 1–4 when tested in accordance with

ASTM E1347 or ASTM E1349. Fluorescent retroreflective materials shall be tested in accordance with ASTM E991. The reflective sheeting shall maintain the colors and luminance factors provided in the appropriate tables throughout its service life.

Table 1

Color	Chromaticity Coordinates (corner points)							
	1		2		3		4	
	X	Y	X	Y	X	Y	X	Y
White	0.303	0.300	0.368	0.366	0.340	0.393	0.274	0.329
Red	0.648	0.351	0.735	0.265	0.629	0.281	0.565	0.346
Orange	0.558	0.352	0.636	0.364	0.570	0.429	0.506	0.404
Brown	0.430	0.340	0.430	0.390	0.518	0.434	0.570	0.382
Yellow	0.498	0.412	0.557	0.442	0.479	0.520	0.438	0.472
Green	0.026	0.399	0.166	0.364	0.286	0.446	0.207	0.771
Blue	0.078	0.171	0.150	0.220	0.210	0.160	0.137	0.038

Daytime Color Specification Limits for Retroreflective Material with CIE 2° Standard Observer and 45/0 (0/45) Geometry and CIE Standard Illuminant D65.

Table 2

Color	Chromaticity Coordinates (corner points)							
	1		2		3		4	
	X	Y	X	Y	X	Y	X	Y
White	0.475	0.452	0.360	0.415	0.392	0.370	0.515	0.409
Red	0.650	0.348	0.620	0.348	0.712	0.255	0.735	0.265
Orange	0.595	0.405	0.565	0.405	0.613	0.355	0.643	0.355
Brown	0.595	0.405	0.540	0.405	0.570	0.365	0.643	0.355
Yellow	0.513	0.487	0.500	0.470	0.545	0.425	0.572	0.425
Green	0.007	0.570	0.200	0.500	0.322	0.590	0.193	0.782
Blue	0.033	0.370	0.180	0.370	0.230	0.240	0.091	0.133

Nighttime Color Specification Limits for Retroreflective Material with CIE 2° Standard Observer and Observation Angle of 0.33°, Entrance Angle of +5° and CIE Standard Illuminant A.

Table 3

Color	Chromaticity Coordinates (corner points)								Luminance Factor (Y %)	
	1		2		3		4		Min	Max.
	X	Y	X	Y	X	Y	X	Y		
Fluorescent Orange	0.583	0.416	0.535	0.400	0.595	0.351	0.645	0.355	25	None
Fluorescent Yellow	0.479	0.520	0.446	0.483	0.512	0.421	0.557	0.442	45	None
Fluorescent Yellow/Green	0.387	0.610	0.369	0.546	0.428	0.496	0.460	0.540	60	None
Fluorescent	0.210	0.770	0.232	0.656	0.320	0.590	0.320	0.675	20	30

Green									
-------	--	--	--	--	--	--	--	--	--

Daytime Color Specification Limits and Luminance Factors for Fluorescent Retroreflective Material with CIE 2° Standard Observer and 45/0 (0/45) Geometry and CIE Standard Illuminant D65.

Table 4

Color	Chromaticity Coordinates (corner points)							
	1		2		3		4	
	X	Y	X	Y	X	Y	X	Y
Fluorescent Orange	0.625	0.375	0.589	0.376	0.636	0.330	0.669	0.331
Fluorescent Yellow	0.554	0.445	0.526	0.437	0.569	0.394	0.610	0.390
Fluorescent Yellow-Green	0.480	0.520	0.473	0.490	0.523	0.440	0.550	0.449
Fluorescent Green	0.007	0.570	0.200	0.500	0.322	0.590	0.193	0.782

Table 4: Nighttime Color Specification Limits for Fluorescent Retroreflective Material With CIE 2° Standard Observer and Observation Angle of 0.33°, Entrance Angle of +5° and CIE Standard Illuminant A.

D. Delineators:

- Description:** Delineators shall be adhesive coated reflective sheeting permanently bonded to sheet aluminum backing.

The aluminum shall be 6061-T6 (ASTM B 209) 0.063-inch-thick sheet properly degreased and etched, or treated with a light, tight, amorphous chromate coating.

Type I Object Marker shall consist of a yellow 18" x 18" reflector unit.

Type II Object Marker shall consist of a 6" x 12" 4" x 8" or size specified reflector unit.

Type III Object Marker shall consist of a 12" x 36" reflector unit.

- Reflective Sheeting:** The reflective sheeting shall be Florescent DG3 sheeting either super high intensity or very high intensity. Super high intensity is defined as that which meets the standards of Type V, VII, or VIII as defined by AASHTO M268 (ASTM D4956). Very high intensity is defined as that which meets the standards of Type IX as defined by AASHTO M268 (ASTM D4956).

In exception to the requirements stated above, the reflective sheeting shall maintain the colors provided in the appropriate tables contained in Section 982.2.G.6 throughout its service life.

- Fabrication:** The aluminum shall be 6061-T6 or 5052-H38 0.063-inch-thick sheet conforming to ASTM B 209. The aluminum shall be properly degreased and etched or treated with a light, tight, amorphous chromate coating.

The reflective sheeting shall be applied to properly treated base panels with mechanical equipment in a manner specified by the sheeting manufacturer.

4. **Shape and Holes:** Delineators shall be punched or sheared to size with 3/4-inch radius corners. Mounting holes shall be as follow:
 - a. The 4 x 8-inch delineators shall have two 1/4-inch holes, 5 inches center to center along the vertical axis.
5. **General Requirements:** The finished delineators shall be free of burrs, scratches, or damaged reflective sheeting and shall have essentially a plane surface.
6. **Delineator Posts:** Posts shall be flanged channel section fabricated from hot rolled carbon steel bars or carbon steel bars and shapes produced from standard rail steel. The posts shall meet the minimum physical properties of ASTM A499, except that the minimum yield strength shall be 70,000 psi. The posts shall meet the physical properties of ASTM A499 and the chemical properties of ASTM A1 for rails 30 pounds per foot and heavier.

The posts shall be coated with a high quality dark green material. All punching, boring, cutting, or shearing shall be done prior to coating. Prior to any punching or boring, the weight of the post shall be a minimum of 1.12 pounds per foot with a tolerance of plus or minus 5 percent. The post length shall be as specified within a tolerance of plus or minus 1 inch. The delineator post shall be punched or bored with thirty 3/8-inch diameter holes on 1.0 inch centers beginning 1.0 inch from the top of the post.

The bottom of the post shall be pointed for ease of installation. The posts shall be machine straightened and have a smooth uniform finish, free from defects affecting strength, durability, or appearance. The allowable tolerance for straightness shall be 1/4 inch in 5 foot.

632.3 CONSTRUCTION REQUIREMENTS

Highway signs and delineators shall comply with the most current MUTCD and Standard Highway Signs, issued by the U.S. Department of Transportation, FHWA.

A. Remove or Salvage Signs and Delineators

1. **Remove Traffic Sign:** The Contractor shall be responsible to remove traffic or other signs as specified in the contract. The signs and the associated posts and bases will be removed and disposed of by the Contractor.
2. **Salvage Traffic Sign:** The Contractor shall be responsible to salvage traffic signs as specified in the contract. The signs, posts, and bases will be removed; disassembled ~~undamaged~~ and returned to the Sioux Falls Traffic Maintenance

Shop in the same condition they were prior to the project. All signs must be removed from the post prior to the removal of the post and base. Care ~~should~~ shall be taken to prevent damage to any of the reflective sheeting. Any signs, posts, or bases damaged during transportation will be replaced at the expense of the Contractor.

3. **Salvage Traffic Sign for Reset:** The Contractor shall be responsible to salvage and store traffic signs to be reset by the Contractor as specified in the contract. The Contractor shall remove the sign prior to removal of the post and base. The post and bases shall be returned to the Sioux Falls Traffic Maintenance Shop unless otherwise specified. Special care ~~should~~ shall be taken by the Contractor to prevent damage to any of the reflective sheeting during storage. Any signs, posts, or bases damaged during storage or transportation will be replaced at the expense of the Contractor.
4. **Salvage Delineator or Object Marker:** The Contractor shall be responsible to salvage delineators or object markers as specified in the contract. The delineators or object markers and associated posts and bases will be removed undamaged and returned to the Sioux Falls Traffic Maintenance Shop. Any delineators, object markers, or associated posts and bases damaged during transportation will be replaced at the expense of the Contractor.

B. Traffic Sign Installation:

1. **Location and Position:** The location of each sign shall be established by a stake bearing the sign number as determined from the plans.

Traffic signs shall be installed on posts, light poles, or mast arms as specified in the contract. The Contractor will be responsible to furnish the necessary stainless steel mounting hardware for each sign.

All R7 and R8 series signs with arrows shall be installed at a 45 degree angle to the street.

2. Sign mounting hardware

- a. All bolts and washers used for mounting signs shall be stainless steel and minimum of 5/16" diameter.
- b. Plastic / nylon washers shall be inserted between the sign face and the stainless washer.
- c. Stainless washers must meet MS 813 standards.
- d. Zinc coated nyloc nuts shall be used to secure signs to the posts

C. Object Markers: Object markers of the type specified shall be erected as shown in the plans.

D. Delineators: Delineators shall be mounted as shown in the plans.

E. Perforated Tube Posts and Flanged Channel Posts: Post size will be specified in the contract for each type of sign. Sign post lengths shown in the contract are

estimates for bidding purposes only. The exact post lengths will be determined during construction. Posts shall be in a plumb position. Unless otherwise specified all signs, including those salvaged for reset by the Contractor will be placed on new posts.

632.4 METHOD OF MEASUREMENT AND BASIS OF PAYMENT

- A. Remove Traffic Sign:** Removed signs will be measured per each sign removed. Multiple signs removed on the same post will be measured as one. Removed signs will be paid for at the contract unit price per each. Payment will be full compensation for all labor and incidentals to remove and dispose of the sign and associated posts and bases.
- B. Salvage Traffic Sign, Salvage Traffic Sign for Reset, and Salvage Delineator or Object Marker:** Salvaged signs will be measured per each sign salvaged. Multiple signs salvaged on the same post will be measured as one. Salvaged signs will be paid for at the contract unit price per each. Payment will be full compensation for all labor, materials, and incidentals including transporting and storing the signs, delineators, and object markers.
- C. Furnish Sign with Reflective Sheeting:** Signs will be measured to the nearest 0.1 foot and the area computed to the nearest 0.1 square foot of the sign face for each sign furnished. Deduction will not be made for rounded corners. Sheet aluminum signs will be paid for at the contract unit price per square foot of the type of sign furnished. Payment will be full compensation for furnishing materials, including borders, legend, and edge trim.
- D. Install Traffic Signs:** Install signs will be measured per each sign installed including Contractor furnished signs, salvaged signs, and City-furnished signs based upon their type of installation location. Multiple signs placed on the same post will be measured separately. Install signs will be paid at the contract unit price per each for the respective type of installation location. Payment will be full compensation for all labor, materials including mounting hardware, and incidentals. Separate measurement and payment will be made for perforated tube posts and flange channel posts.
- E. Object Markers:** Object markers quantities will be determined by count of each type. Object markers will be paid for at the contract unit price per each. Payment will be full compensation for furnishing and installing materials, including posts, reflective panels, and hardware.
- F. Delineators:** Delineator quantities will be determined by count of each type. Delineators will be paid for at the contract unit price per each. Payment will be full compensation for furnishing and installing materials, including posts, reflectors, and hardware.
- G. Perforated Tube Posts and Flange Channel Posts:** Post quantities for steel posts, other than those used for delineators and object markers, will be measured to

the nearest 0.1 foot. Perforated tube posts and flange channel posts will be paid for at the contract unit price per foot. Payment will be full compensation for all labor, materials, and incidentals including post anchors, anchor sleeves, mounting hardware, telescoped inner post sections, and anchor plates.

635A.1 DESCRIPTION

This work consists of furnishing and installing materials and equipment necessary for the operation of traffic signals.

635A.2 MATERIALS

- A. City-Furnished Equipment and Contractor-Furnished Equipment:** The City will typically supply the following equipment unless otherwise specified: signal poles, mast arms, traffic signal heads, controller and cabinet, battery backup system, and pedestrian push buttons. The Contractor is responsible to furnish and install all other equipment including the incidental items needed to install City-furnished materials. Unless otherwise specified, anchor bolts are supplied by the City on all new traffic signal pole installations, but they are the Contractor's responsibility to furnish and install on traffic signal poles that are reset on a project.

The City will furnish the Emergency Vehicle Preemption (EVP) detector heads and controller unit. The Contractor will be required to furnish and install the confirmation light assembly, associated cable, and the EVP detector cable.

The Contractor will be responsible to pick up all City-furnished material from the City Traffic Shop located at 1100 East Chambers Street. The Contractor must provide five days notice to arrange for pick up of materials. The phone number for the Traffic Shop is 367-7058.

- B. Tax on City-Furnished Traffic Signal Materials:** The Contractor is responsible for sales tax at the rate of ~~5.92~~ 6.0 percent on all City-furnished traffic signal materials.

C. Electrical Grounding and Bonding:

- 1. Grounding Wire:** Grounding wire from power feed equipment to the ground rod shall be bare, soft drawn copper, size per NEC. Grounding wire from pole to ground rod shall be bare, soft drawn copper, minimum size No. 6 AWG.
- 2. Bonding Conductors:** Bonding conductors shall be of the same size and insulation grade as the associated circuit conductors. Load size bonding jumpers shall not be smaller than the applicable size listed by the NEC, Table 250-95.
- 3. Ground Rods:** Ground rods shall be copper-coated electrodes in accordance with Underwriters Laboratory (UL). The size and length shall conform to NEC requirements.

D. Electrical Conduit:

1. **Rigid Steel Conduit:** Conduit and fittings shall meet the requirements of UL 6 and 514 and shall be hot dip galvanized. Each section of conduit shall bear the UL label.
2. **Rigid Nonmetallic Conduit:** Conduit and fittings shall be polyvinyl chloride heavy wall meeting the requirements of UL 651 and 514. Use and installation of PVC Schedule 40 and 80 shall be in accordance with NEC Article 347 and each section shall bear the UL label. When nonmetallic conduit is to be used in areas subject to vehicular traffic, it shall be Schedule 80.
3. **Innerduct:** Innerduct conduit shall be SDR 13.5 polyethylene. The nominal duct size shall be as indicated in the plans.

E. Junction Boxes: Shall meet the following requirements:

Corrugated metal pipe shall conform to the requirements of AASHTO M 36.

Lid and cover assemblies for corrugated metal junction boxes shall be cast iron Neenah Foundry Co. R5900A Series or an Engineer approved equal. The word TRAFFIC shall be cast into the top of the cover.

All conduits, other than innerduct, coming into and leaving the junction box shall be rigid steel for at least 5 feet outside of the junction box. These conduits will have a grounding bushing attached and a grounding wire installed to bond all conduits to the junction box using an appropriately sized terminal lug bolted to the wall of the junction box.

- F. Concrete Footings:** Concrete for traffic signal pole and controller cabinet footings shall meet the requirements for Class M6 concrete. Cement shall be Type II. Vertical reinforcement shall be deformed unless otherwise noted and shall conform to the requirements of ASTM A 615/AASHTO M31 Grade 40. Spiral reinforcing may also be fabricated from cold drawn wire conforming to ASTM A 82 or hot rolled plain bars conforming to ASTM A 651/AASHTO M31 Grade 40.

- G. Anchor Bolts:** When the Contractor is responsible to furnish the anchor bolts [for mast arm poles](#) it will be their responsibility to contact the pole manufacturer and receive the manufacturer's recommendation on the proper anchor bolt selection meeting the specifications listed below. The plans will indicate the manufacturer of the poles and the anchor bolt diameter and length.

Bolts conforming to ASTM A307, A449, and F1554 are allowed to be used for anchor bolts. Other materials may be submitted for approval providing the following information is submitted:

1. The allowable stresses that are to be used for design based on the proposed material.
2. Minimum average Charpy V-Notch impact values for 15 ft-lb at -20 degrees F in accordance with ASTM A370.
3. Ultimate wedge tensile strength in accordance with ASTM A370.
4. Yield strength reports in accordance with ASTM A370.

Anchor bolts shall be either threaded full length or equipped with a satisfactory mechanical end anchorage. Details for any mechanical end anchorage shall be included in the shop plans submittal for prior approval. Swaged anchor bolts and anchor bolts with hooked end anchorage are not allowed.

The anchor bolt threads shall be 3 inches plus the projection. At least 3 inches of threads shall be below the top of the concrete. Rolled UNC threads are required for all bolts.

Nuts shall conform to ASTM A194, 2H or ASTM A563, DH. All nuts are to be heavy hex.

Washers shall conform to ASTM F436 or ASTM F959.

Bolts, nuts, and washers shall be galvanized in accordance with ASTM A153 or B695, Class 50. The minimum length of galvanizing shall be the bolt projection plus 3 inches.

Bolt Testing: Bolt testing shall conform to the following:

When bolts conforming to ASTM A325, A449, A307, F1554, or others are designated for use in the plans and/or shop drawings, a Certified Mill Test Report for each type designated shall be submitted for approval to the Engineer a minimum of 14 days prior to incorporating these bolts into the work. Certified Mill Test Reports for nuts, washers, direct tension indicators, and other required hardware shall be included.

The Certified Mill Test Reports for the bolts shall include test results, tested in accordance with the applicable ASTM Specifications, for the following:

Test	A325	A449	A307	F1554	Others
Chemical Analysis	X	X	X	X	X
Hardness Test	X	X	X		X
* Tensile Strength (By Wedge Test Method)	X	X	X	X	X
** Proof Load Test	X	X	X	X	X

*** Rotational Capacity Test	X				
**** Charpy V-Notch				X	X

* Certified Mill Test Report shall state that Wedge Test Method was used. For ASTM A307 and A449 bolts, the Wedge Test Method is required only for square and hexagon head bolts. The Wedge Test Method is not required for ASTM F1554 bolts. See appropriate specifications.

** Proof Load Test and/or Yield Test as allowed or specified by the applicable ASTM Specification.

*** Rotational Capacity Test required for Zinc Coated (Galvanized) bolts only. This test shall be conducted using the actual nuts that are used on the project.

**** Anchor bolts conforming to ASTM F1554 Grade 36 and 55 shall satisfy Supplemental Requirement S4. Anchor bolts conforming to ASTM F1554 Grade 105 shall satisfy Supplemental Requirement S5.

Note: The requirements set forth in this table are to alert the Contractor to the requirements for testing and certification as specified in the applicable ASTM Specifications and are not intended to alter the requirements of the ASTM Specifications

Proof load tests on bolts (ASTM F606 Method 1) are required. Wedge testing of full size bolts is required in accordance with AASHTO M164 (ASTM A325). Galvanized bolts shall be wedge tested after galvanizing. Proof load tests (AASHTO M291) are required for the nuts and shall be performed after galvanizing, overtapping, and lubricating.

H. Electrical Power Cable: Electrical cables shall be type THW, THWN, or XHHW rated for 600 volts AC and be clearly and durably marked with the UL label, type of insulation, number of conductors, and the AWG size.

I. Traffic Signal Control Cable:

1. Conductors: Shall meet either of the two specifications below.

- a. General Purpose Control Cable with stranded copper conductors, ICEA S-61-402, PE-PV Insulated (20-10), 600 volts.
- b. General Purpose Control Cable, with stranded copper conductors, Aerial and Duct, IMSA 20-1, 600 volts.

2. Colors: Conductor insulation shall be colored in accordance with ICEA S-61-402, Appendix K, Table K-1 or IMSA 19-1 Table II.

3. **Markings:** The cable shall be marked with the name of the manufacturer, rated voltage, UL label, AWG size, and number of conductors.

J. Power Feed Equipment:

Meter Pedestal shall be Milbank U4322-0-5T95 Terminal, Single Meter Pedestal or approved equal.

Meter Pedestal shall be Milbank U4323-0-5T95 Terminal, Double Meter Pedestal or approved equal.

Shall meet NEMA standard for rain tight.

Size shall be as required to house required components.

Shall be rated for service entrance equipment.

Required components:

1. A copper bus rated for the voltage, current, and phases required by the plans.
2. Branch circuit breakers meeting plan requirements for amps, voltage, and phases. Minimum A.I.C. shall be 10,000.

- K. Preformed Detector Loops:** The preformed detector loops shall be any one of the following three models: Patriot-Detection LLC Model CG16MMC, De-Tech Manufacturing Model HDR, and Never-Fail Model LS. All preformed detector loop shall be 6 feet x 6 feet square unless shown differently on the plans. All loops shall be constructed with four (4) turns of wire. The lead-in lengths shall be as specified on the plans.

- L. Traffic Counter Surface Utility Box:** The Traffic Counter Surface Utility box shall be an Emerson Network Power model number UPCBD2. The terminal strip shall be as detailed on the standard plate.

- M. Emergency Vehicle Preemption (EVP) Equipment:** EVP detector cable shall be as approved by the manufacture. The plans shall indicate the manufacture of the EVP equipment.

Mounting hardware shall consist of 3/4-inch NPT electrical pipe materials including a malleable Iron "T" approved for rain tight locations, threaded nipples, and single lamp holder approved for outdoor use. The use of a PELCO AB-0155-42 Band Mount Mini-Brac, or approved, equal shall be used where no integrated threaded outlet exists on the mast arm. The confirmation lamp shall be a 90-watt flood lamp rated for outdoor use.

Confirmation lights shall be wired with IMSA 19-1, 2, or 3 - #14 AWG stranded wire cable for single direction indication and IMSA 19-1, 3 - #14 AWG stranded wire cable for dual direction indications.

635A.3 CONSTRUCTION REQUIREMENTS

A. General

Installations shall comply with applicable sections of the NEC, state regulations, and local ordinances. Licenses or permits required shall be obtained by and at the expense of the Contractor.

The Contractor shall be responsible for the locating of all traffic signal infrastructure from the start of the project until the traffic signal work has been accepted and the as-built information has been provided to the City Engineer's Office.

Equipment and materials furnished shall be new.

The Contractor shall arrange for necessary electrical services at locations specified, which have previously been agreed to by the City and the utility company.

All cables shall be permanently identified in hand holes, junction boxes, pedestal bases, and controller cabinets. Labels to identify cables shall be plastic adhesive tape which is clearly and legibly embossed or printed with numerals and letters and permanently attached to the cable.

B. Final Inspection: Upon completion of the traffic signal installation or associated work, the Contractor shall complete a Traffic Signal Inspection Checklist furnished by the City Traffic Engineer to assure that all installation items are completed. Upon completion and submission of this form, the Contractor may request a final inspection from the City Traffic Engineer.

C. Warranties and Maintenance: The Contractor is responsible for routine maintenance including providing emergency power to the traffic signal until the signal system has been accepted by the City Traffic Engineer. Upon acceptance, the Contractor shall be relieved of routine maintenance responsibility.

The Contractor must provide a one-year warranty on the traffic signal system from the time the system is accepted. The Contractor is not responsible for providing a one-year warranty on City-furnished materials, except they shall be responsible for the replacement or repair of City-furnished materials damaged due to poor workmanship or negligence.

Warranties and guarantees offered by electrical and mechanical equipment manufacturers on Contractor-furnished materials shall be turned over to the City and the City shall be named as the obligee.

- D. Removal Signal Pole Footings and Controller Cabinet Footings:** The Contractor is to completely remove all signal pole and controller cabinet footings when specified. When field conditions prevent a signal pole footing from being completely removed, the footing, anchor bolts, and all pipes shall be removed to a depth of 2 feet below the final grade.
- E. Salvage Signal Equipment:** The Contractor shall be responsible to salvage all signal equipment specified including signal poles, mast arms, traffic signal heads, controller cabinets including controller, signal and power cables, and junction box frame and lids. This equipment will be removed and returned to the Sioux Falls Traffic Maintenance Shop in the same condition in which it was found at the beginning of the project. Any salvaged equipment damaged during removal or transportation will be replaced at the expense of the Contractor. Electrical cCables shall not be cut further than 4 inches from the terminations and, be shall be neatly coiled.
~~E. and shall be returned to the Sioux Falls Traffic Maintenance Shop in the longest lengths as practical.~~
- F. Electrical Grounding and Bonding:** Grounding and bonding of electrical power feeds shall be in strict compliance with the National Electrical Code (NEC), local ordinances, and local utility company rules.
- G. Electrical Conduit:** Unless otherwise specified, the electrical conduit will be furnished and installed by the Contractor.

Unless otherwise specified in the plans or required by the NEC, the type of conduit shall be:

RGSC shall be used to connect all junction boxes, traffic signal footings, and controller cabinets at a signalized intersection.

Innerduct shall be used on all fiber optic cable runs between junction boxes away from signalized intersections. RGSC shall be used to sleeve innerduct conduit under roadways. RGSC shall be used in the short segments between the junction box and controller cabinet or between junction boxes at the signalized intersections for fiber optic cable. All innerduct conduits shall include a 1c #12 trace wire. The trace wire shall be continuous from junction box to junction box. The trace wire shall be spliced using a Buchanon crimp sleeve and left bare (insinuated). The trace wire shall be considered incidental to the cost of the conduit.

All innerduct conduits shall be sealed using TDUX Inflatable Sealing System manufactured by Tyco Electronics.

Use and installation shall conform to NEC and the following requirements:

1. The size of the conduits installed shall not be less than the electrical trade size specified.
2. The location and direction of conduit runs is diagrammatic and may be shifted to meet field conditions.
3. The minimum depth for all RGSC and Rigid Nonmetallic Conduit is 24" The minimum depth for all Innerduct is 36".
4. Underground conduit shall be placed by trenching, jacking, or drilling methods. The use of the trenching method for placement under existing roadway pavements will be permitted only after jacking or drilling attempts have failed. The Contractor shall not use a machine requiring flowing water for installation of conduit under streets or roadways unless approved by the Engineer.

Trenches shall be backfilled and compacted to the same density as the adjoining ground. Roadway surfaces, sidewalks, curb and gutters, sod, etc., which are removed by trenching operations shall be replaced. The cost of removing and replacing these materials shall be incidental to the bid price for the conduit.

5. Where trenching operations require the removal of concrete pavement or sidewalk, the concrete shall be sawed full depth along the removal lines or the concrete shall be removed to existing joints.
6. Metal conduit open ends in junction boxes or above concrete foundations shall be provided with an approved threaded conduit grounding bushing.

Nonmetallic conduit open ends shall have an approved bell end or bushing installed to prevent damage to cable or conductors.

7. Metal conduit ends shall be reamed to remove sharp edges and burrs. Couplings shall be tightened until the ends of the conduit are brought together.

H. Tie to Existing Conduit, Signal Footing, or Junction Box: When specified, the Contractor shall tie the proposed conduit to or into an existing conduit, signal footing, or junction box. The Contractor shall furnish all materials to properly tie into the specified location.

I. Junction Boxes: Unless otherwise specified, the junction boxes will be furnished and installed by the Contractor.

The top of the junction box cover shall be flush with final surfaced areas. The top of the junction box must match the grade of the surrounding surface.

The diameter of the holes in the junction or pull box walls shall be no more than 1/4 inch larger than the diameter of the conduit. The area around the conduit shall be sealed with a material that will prevent dirt intrusion into the junction box.

- J. Concrete Footings:** The bottom of concrete footings shall rest on firm ground. The sides of the footings shall be formed by using an auger and then placing the concrete against the natural soil. A suitable form shall be used above existing ground line and all exposed portions shall be formed to present a neat appearance. An acceptable form shall be used if the excavation is larger than the standard footing dimensions. Backfill must be replaced to a density equal to or greater than adjacent undisturbed natural soil. Finished base shall be level and have steel trowel finish.
- K. Anchor Bolts:** Anchor bolts shall be installed as specified in the plans or by the manufacturer.
- L. Electrical Power Cables:** Unless otherwise specified, the electrical power cables will be furnished and installed by the Contractor.

Cables shall be installed using methods that will not injure the jacket, insulation, or conductors. All cables within a single conduit shall be placed at the same time. When powder or compound is required to ease pulling, the powder or compound shall be used according to manufacturer recommendations and the use shall not injure the cable.

The Contractor may substitute a multiple conductor cable having more conductors than specified if conduit fill requirements are not exceeded, subject to approval by the Engineer.

The Contractor may provide power feed cables with conductor AWG size larger than specified where conduit fill requirements are not exceeded. All power feed cables must extend from terminal to terminal for circuits used with no splices allowed.

- M. Traffic Signal Control Cables:** Unless otherwise specified, the traffic signal control cables will be furnished and installed by the Contractor.

Traffic signal conductors shall be continuous from the controller cabinets to the pole bases. Splices from the signal control cables to the signal head cables shall only be done in the signal pole bases. All traffic signal heads shall be wired with IMSA multi-conductor cables.

Cables shall be installed using methods that will not injure the jacket, insulation, or conductors. All cables within a single conduit shall be placed at the same time. When powder or compound is required to ease pulling, the powder or compound shall be used according to manufacturer recommendations and the use shall not injure the cable.

The Contractor may substitute a multiple conductor cable having more conductors than specified if conduit fill requirements are not exceeded, subject to approval by the Engineer.

The Contractor shall leave no more than 6 feet of excess cable in the cabinet.

The Contractor shall use Buchanan crimp connectors and insulating caps on all wire terminations in the signal bases. All cable splices shall be suspended off the signal pole footing surface with capped end up to shed water.

The Contractor shall furnish and install approved strain relief devices on all cables exiting the mast arm.

N. Power Feed: The power feed shall be furnished and installed by the Contractor.

Power feed equipment shall be installed in accordance with the plans and the manufacturer's recommendations. The power feed shall be exclusively for traffic signals and shall be permanently marked on the exterior with the address of the location and the word "TRAFFIC."

O. Signal Poles: Unless otherwise specified, the signal poles will be furnished by the City and installed by the Contractor.

The following shall apply to traffic signal poles:

1. Poles shall be plumb after the bracket arms, signal heads, fittings, and fixtures have been installed and connections have been made. Nuts shall be firmly tightened as per manufacturer's recommendations. Signal heads shall be mounted plumb.
2. Field repair of damaged galvanizing shall be done in accordance with AASHTO M36.
3. If the gap between the concrete footing and the signal pole base is greater than 1/4 inch, it shall be sealed and provide an approved drain hole.
4. When a luminaire arm is specified to be installed as part of the signal pole the luminaire arm shall be considered part of the signal pole installation and will include installing the City furnished UF wire, luminaire arm, luminaire, bulb, and photo eye.

P. Controller Cabinet:

1. Unless otherwise specified, the controller cabinet will be furnished by the City and installed by the Contractor.

2. The controller cabinet shall be installed according to the directions supplied by the manufacturer. A 100% silicone caulk shall be used to seal the cabinet flange to the concrete footing to prevent the incursion of water and shall be placed the total distance of the flange.
3. Wiring and connections in the controller cabinet shall be neat, firm, and in accordance with industry standards.
4. Two sets of wiring diagrams and one maintenance and operation manual shall be supplied for each controller that is required. The Contractor shall place all diagrams and manuals in the controller cabinet.
5. If the controller cabinet base is not located next to a sidewalk, the Contractor shall provide a 3-foot by 4-foot, 4-inch-thick concrete pad in front of the controller base. The cost shall be considered incidental to the controller cabinet footing unless there are other sidewalk bid items included in the contract.

Q. Controller: Unless otherwise specified, the controller and all other cabinet components will be furnished by the City and installed by the Contractor.

The installation of controller and all other cabinet components and location in the cabinet shall be accordance with directions supplied by the manufacturer.

R. Battery Backup System: The Contractor shall install City-furnished battery backup equipment, consisting of the batteries and the control unit. The Contractor shall follow the manufacturer's installation instructions.

When the battery backup equipment is installed in a new traffic signal cabinet, the automatic transfer switch is already wired into the cabinet. If installed in an existing cabinet, the Contractor shall wire in a City-furnished automatic transfer switch according to manufacturer's instructions. If this installation of the automatic transfer switch is required, it shall be noted on the plan sheet.

If the existing traffic signal cabinet does not have room to store the battery backup equipment, the Contractor shall furnish and install either a NS-Riser unit for a Type P signal cabinet or an Alpha BSM-4 Battery Side Module enclosure to be mounted on the existing cabinet. The plans will note if this is required and what type to furnish.

S. Detector Loops:

Unless otherwise specified, the preformed detector loops and sawed-in detector loops will be furnished and installed by the Contractor.

1. **Clearance Between Loops and Metallic Objects:** The Contractor shall provide sufficient clearance between detector loops and metallic objects such

as manhole covers, drop inlets, etc., to avoid interference with the operation of the loop.

2. Sawed-in Detector Loops:

Lead-in saw cuts shall clear each other by a minimum of 1 foot.

Backer rod material (if needed) shall be cut into 1-inch by 2-inch lengths and spaced not farther apart than 2 feet.

Saw slots in the pavement shall be blown out with compressed air and shall be clean and free of loose grit and moisture when wires are placed and sealer is applied.

The flexible imbedding loop sealer shall be placed into the bottom of the saw cut to allow the loop sealer to get under the loop wire (or lead-in wire) during installation. The loop wires shall be pushed into the sawed slots with a blunt wood stick (not with a screwdriver). The wires shall be laid in the slots so there are no kinks or curls and without straining or stretching the insulation.

The flexible embedding sealer shall completely surround the 1/4-inch tube, displace all the air within the sawed slot, and fill the area of the sawed slot except for that area which is taken up by the backer rod and the wires.

Conductor size for loops and leads shall not be smaller than 14 AWG stranded copper meeting IMSA Spec. 51-5, Type XHHW, with Polyethylene tube jacket.

Lead-ins shall be twisted at least five (5) turns per foot.

Splices shall not be made in the loop or lead-in conductors, except in the junction box. All splices are to be done in the field where the installation of the loop takes place.

Lead-in conductors shall be permanently labeled in the junction box. Each lead-in conductor shall extend into the junction box a minimum of 6 feet. The home-run cable shall also extend a minimum of 6 feet into the junction box.

3. Preformed Loops:

Preformed loops are to be placed in the surface of the base course prior to placement of proposed pavement.

Preformed loops are to be centered under each proposed driving lane. The exact location of the loop will be determined in the field by Traffic Engineering personnel.

All conductors leading from each loop to the junction box or surface utility box may be placed in the same trench.

- 4. **Lead-ins:** Lead-in conductors shall be twisted at least one turn per foot. Splices shall not be made in the loop or lead-in conductors except in the junction box. Lead-in conductors shall be permanently labeled in the junction box. Each lead-in conductor shall extend into the junction box a minimum of 6 feet. The home-run cable shall also extend a minimum of 6 feet into the junction box.

- 5. **Splices in Junction Boxes:** Splices shall be as follows:

Crimping bare connectors with a non-insulated butt connector and soldering with a soldering iron (not a torch) with sufficient heat applied to the splice. Cold soldered joints are not acceptable.

Splices shall be insulated to prevent electrical shorting and encapsulated with an epoxy encapsulating kit.

The bare drain wire from the home-run cable shall be cut at the jacket and insulated with electrical tape.

- 6. **Loop Connections in the Controller Cabinet:** Terminal board screws shall be turned down tightly on the lug. Shielding shall be grounded at the controller only.

- 7. **Loop Testing:** After installation, each loop shall be tested by the Contractor. Necessary test equipment shall be furnished by the Contractor and test results recorded and furnished to the Engineer. Each detector loop shall conform to the following:

Continuity:	5 ohms maximum
Resistance, loop to ground:	100 megaohms minimum
Inductance:	100–500 micro henries

Ground resistance reading shall read greater than 100 megaohms to ground, measured on a 500-volt DC megger or larger.

- T. **Traffic Counter Surface Utility Box:** The Contractor will be required to furnish and install the traffic counter surface utility box, one 8-foot-long by 2-inch-square telspar post, and two 4- by 8-inch white delineators at each specified location.

U. Vehicular and Pedestrian Traffic Signal Heads:

- 1. Unless otherwise specified, the vehicular and pedestrian traffic signal heads will be furnished by the City and installed by the Contractor.

2. Signal heads are to be rigidly attached to signal poles and shall be vertical from the street approach, which they control. All heads shall be level and plumb. All signal heads mounted on the same mast arm shall be level across the bottom of the back plates. Side of pole signal heads shall be mounted on the side of the pole away from the street.
3. Signals heads, which are mounted in place, but are not in operation, shall be hooded, have the lenses blocked, or positioned so the lenses are not visible to any approach.
4. Backplates for three and five-section signal heads shall be attached using zinc plated #10x1/2" hex head tapping screws and zinc plated 3/16"x3/4" fender washers. These screws and washers shall be considered incidental to the cost of mounting the signal head.

V. Pedestrian Push Buttons, Pedestrian Crossing Signs, and Pedestrian Push Button Pole:

1. Unless otherwise specified, the pedestrian push buttons will be furnished by the City and installed by the Contractor. All other materials including push button pole, pedestrian crossing signs, and conduit shall be furnished and installed by the Contractor.
2. Pedestrian push buttons shall be accessible a maximum horizontal distance of 10 inches from an asphalt or concrete surface that does not exceed a 2 percent slope in any direction and is at least 36 inches by 48 inches.
3. Pedestrian push buttons shall be mounted at a nominal height of 42 inches above the surface the button is accessible from. All pedestrian push buttons shall be mounted using 1/4-inch – 20 bolts, stainless or zinc coated.
4. Pedestrian push buttons shall be mounted on the traffic signal pole whenever possible. If necessary to meet ADA requirements, the Contractor must mount the pedestrian push button on a push button pole(telspar post) as specified.
5. The Contractor shall furnish and install the appropriate pedestrian crossing sign at each location a push button is installed.

W. Emergency Vehicle Preemption (EVP) Equipment: The Contractor shall install City-furnished EVP detector heads and the EVP controller unit. The Contractor shall furnish and install the approved EVP detector cable, confirmation lights, sockets, and confirmation light cable. The Contractor shall also be responsible to furnish and install all mounting hardware for both the detector heads and confirmation lights.

The EVP detector cable and the confirmation light cable shall be a continuous section from termination point in traffic signal cabinet to the EVP detector and confirmation light terminals.

EVP detector heads and confirmation lights shall be mounted to the signal mast arm approximately 6 feet from the tip of the mast arm using 3/4-inch NPT electrical pipe materials including a malleable Iron "T" approved for rain-tight locations, threaded nipples, and single lamp holder approved for outdoor use. The use of a PELCO AB-0155-42 Band Mount Mini-Brac, or approved, equal shall be used where no integrated threaded outlet exists on the mast arm. All equipment shall be securely mounted to be level/plumb and retain its alignment.

Confirmation lights shall be wired with IMSA 19-1, 2, or 3 - #14 AWG stranded wire cable for single direction indication and IMSA 19-1, 3 - #14 AWG stranded wire cable for dual direction indications.

635A.4 METHOD OF MEASUREMENT AND BASIS OF PAYMENT

- A. Tax on City-Furnished Traffic Materials:** Measurement and payment for tax on City-furnished material will be on a lump sum basis. The estimated amount of tax will be listed in the contract documents and final payment will be adjusted based on the final value of the City-furnished material.
- B. Remove Signal Pole Footing and Remove Controller Cabinet Footing:** Measurement will be per actual number of signal pole or controller cabinet footings removed. Payment will be at the contract unit price per each and shall be full compensation for all labor, equipment, and incidentals.
- C. Salvage Signal Equipment:** Measurement and payment for salvaging traffic signal equipment will be on a lump sum basis. Payment will be full compensation for all labor, equipment, and incidentals.
- D. Electrical Grounding and Bonding:** No field measurement will be made. The cost of furnishing and installing conduits for grounding will be incidental to the cost of footing, power feed equipment, junction box, or controller cabinet to be grounded.
- E. Electrical Conduit:** The plan shown quantity of each type and size specified will be the measured quantity unless changes are ordered by the Engineer. Conduit of each type and size specified will be paid for at the contract unit price per foot. Payment will be full compensation for required materials, labor, equipment, and incidentals.
- F. Tie to Existing Conduit, Signal Footing, or Junction Box:** Measurement will be by actual count of the various types of connections made. Payment for this item will be at the contract unit price per each. Payment will be full compensation for required materials, labor, equipment, and incidentals.

- G. Junction Boxes:** Measurement will be by actual count of the various types and sizes of junction boxes furnished and installed. Payment for this item will be at the contract unit price per each. Payment will be full compensation for required materials, labor, equipment, and incidentals.
- H. Concrete Footings:** Concrete footings of the various diameters will be measured to the nearest vertical foot furnished and installed. Payment for concrete footings of the various diameters will be at their respective contract unit prices per foot. Payment will be full compensation for all materials, labor, and incidentals necessary to furnish and install the footings.
- I. Controller Cabinet Footing:** Measurement will be by the actual count of controller cabinet footings furnished and installed for each type and size specified. Controller cabinet footings will be paid for at the contract price per each. Payment will be full compensation for all required materials, labor, and incidentals to furnish and install the controller cabinet footings including the ground rod, 3/4 PVC conduit, and anchors
- J. Anchor Bolts:** Measurement will be by actual count of anchor bolts furnished and installed in each footing. Cost for anchor bolts will be at the contract unit price per each. No measurement or payment will be made if the anchor bolts are furnished by the City and the cost to install the anchor bolts will be considered incidental to the concrete footings.
- K. Electrical Power Cable:** The plan shown quantity of each type, number of conductors, and size specified will be the method of measurement unless changes are ordered by the Engineer. Electrical power cable of each type, number of conductors, and size specified will be paid for at the contract unit price per foot. Payment will be full compensation for required materials, labor, equipment, and incidentals.
- L. Traffic Signal Control Cable:** The plan shown quantity of each type, number of conductors, and size specified will be the method of measurement unless changes are ordered by the Engineer. Traffic signal control cable of each type, number of conductors, and size specified will be paid for at the contract unit price per foot. Payment will be full compensation for required materials, labor, equipment, and incidentals.
- M. Power Feed Equipment:** Measurement will be by actual count of the type of power feed locations furnished and installed. Payment for this item will be at the contract unit price per each. Payment will be full compensation for furnishing and installing power feed equipment including meter panel and base, circuit breakers, fuses, contactor, manual on/off switch, power cables and conduit between the transformer and meter pedestal, and other materials and fixtures required. Any fees charged by the power company associated with the power feed hookup will be the responsibility of the City.

- N. Install Signal Poles:** Measurement will be by actual count of the various types and sizes installed. Payment for installing City-furnished signal poles of the various types will be at the contract unit price per each. Payment will be full compensation for required labor, equipment, and incidentals.
- O. Install Signal Heads:** Measurement will be by actual count of the various types and sizes of City-furnished signal heads installed. Payment for this item for the various sizes will be at the contract unit price per each. Payment will be full compensation for installing and wiring signal heads including City-furnished mounting hardware, brackets, and back plates.
- P. Install Controller Cabinet:** Measurement will be by actual number of City-furnished controller cabinets installed. Payment for installing City-furnished controller cabinets will be at the contract unit price per each. Payment will be full compensation for required labor, equipment, and incidentals.
- Q. Install Traffic Signal Controller and Cabinet Wiring:** No field measurement will be made. Costs for installing the City-furnished traffic signal controller, cabinet components, and all cabinet wiring will be included in the contract unit price for the installation of the controller cabinet.
- R. Install Battery Backup System:** Measurement will be actual count of battery backup systems installed. Payment for this item will be at the contract unit price per each. Payment will be full compensation for required materials, labor, equipment, and incidentals.
- S. Preformed Detector Loops:** Measurement will be actual count of preformed detector furnished and installed at traffic signals or permanent traffic counter locations. Payment for this item will be at the contract unit price per each. Payment will be full compensation for required materials, labor, equipment, and incidentals.
- T. Sawed-in Detector Loops:** Measurement will be actual count of sawed-in detector loops furnished and installed. Payment for this item will be at the contract unit price per each. Payment will be full compensation for required labor, material, equipment, and incidentals.
- U. Traffic Counter Surface Utility Box:** Measurement will be actual count of traffic counter surface utility boxes furnished and installed. Payment for this item will be at the contract unit price per each. Payment will be full compensation for required materials, labor, equipment, and incidentals. Materials include the box, terminal strip, 8-foot-long by 2-inch-square telspar post, and delineators. Payment also includes costs for wiring the loops into the box.
- V. Install Pedestrian Push Buttons:** Measurement will be by the actual count of City-furnished pedestrian push buttons installed based on their respective installation type. Payment for this item will be at the contract unit price per each. Payment will be full compensation for all materials, labor, equipment, and incidentals..

- W. Pedestrian Crossing Sign and Pedestrian Push Button Pole:** Measurement will be by the actual count of pedestrian signs and push button poles (telspar posts) installed. Payment for these items will be at the contract unit price per each. Payment will be full compensation for all materials, labor, equipment, and incidentals.
- X. Emergency Vehicle Preemption (EVP) Unit:** Measurement will be per each type of EVP detector head and EVP controller unit. Measurement for EVP cable and confirmation light cable will be measured to the nearest foot. Payment for EVP detector heads and controller units will be at the contract unit price per each. Payment for EVP cable and confirmation light cable will be at the contract price per foot. Payment will be full compensation for all materials, labor, equipment and incidentals. The confirmation socket and bulb are considered incidental to the detector heads.