



Agilent 218 Solvent Delivery Module

User Manual



Agilent Technologies

Notices

© Agilent Technologies, Inc. 2012, 2013

No part of this manual may be reproduced in any form or by any means (including electronic storage and retrieval or translation into a foreign language) without prior agreement and written consent from Agilent Technologies, Inc. as governed by United States and international copyright laws.

Manual Part Number

G9300-90001

Edition

01/2013

Printed in Germany

Agilent Technologies
Hewlett-Packard-Strasse 8
76337 Waldbronn

This product may be used as a component of an in vitro diagnostic system if the system is registered with the appropriate authorities and complies with the relevant regulations. Otherwise, it is intended only for general laboratory use.

Warranty

The material contained in this document is provided “as is,” and is subject to being changed, without notice, in future editions. Further, to the maximum extent permitted by applicable law, Agilent disclaims all warranties, either express or implied, with regard to this manual and any information contained herein, including but not limited to the implied warranties of merchantability and fitness for a particular purpose. Agilent shall not be liable for errors or for incidental or consequential damages in connection with the furnishing, use, or performance of this document or of any information contained herein. Should Agilent and the user have a separate written agreement with warranty terms covering the material in this document that conflict with these terms, the warranty terms in the separate agreement shall control.

Technology Licenses

The hardware and/or software described in this document are furnished under a license and may be used or copied only in accordance with the terms of such license.

Restricted Rights Legend

If software is for use in the performance of a U.S. Government prime contract or subcontract, Software is delivered and licensed as “Commercial computer software” as defined in DFAR 252.227-7014 (June 1995), or as a “commercial item” as defined in FAR 2.101(a) or as “Restricted computer software” as defined in FAR 52.227-19 (June 1987) or any equivalent agency regulation or contract clause. Use, duplication or disclosure of Software is subject to Agilent Technologies’ standard commercial license terms, and non-DOD Departments and Agencies of the U.S. Government will

receive no greater than Restricted Rights as defined in FAR 52.227-19(c)(1-2) (June 1987). U.S. Government users will receive no greater than Limited Rights as defined in FAR 52.227-14 (June 1987) or DFAR 252.227-7015 (b)(2) (November 1995), as applicable in any technical data.

Safety Notices

CAUTION

A **CAUTION** notice denotes a hazard. It calls attention to an operating procedure, practice, or the like that, if not correctly performed or adhered to, could result in damage to the product or loss of important data. Do not proceed beyond a **CAUTION** notice until the indicated conditions are fully understood and met.

WARNING

A **WARNING** notice denotes a hazard. It calls attention to an operating procedure, practice, or the like that, if not correctly performed or adhered to, could result in personal injury or death. Do not proceed beyond a **WARNING** notice until the indicated conditions are fully understood and met.

In This Book

This manual contains information on:

- G9300A Agilent 218 Isocratic Solvent Delivery Module
- G9301A Agilent 218 Add-on Solvent Delivery Module
- G9306A Agilent 218 Injection Pump

1 Introduction

This chapter gives an instrument overview.

2 Site Requirements and Specifications

This chapter provides information on environmental requirements, physical and performance specifications.

3 Installation

This chapter gives information about the installation of your instrument.

4 Using the 218 Solvent Delivery Module

This chapter explains the operational parameters of the instrument.

5 Optimizing Performance

This chapter gives hints on how to optimize the performance or use additional devices.

6 Troubleshooting and Diagnostics

This chapter gives an overview about the troubleshooting and diagnostic features.

7 Maintenance and Repair

This chapter describes the maintenance of the instrument.

8 Parts

This chapter provides information on parts for the instrument.

9 Cables

This chapter provides information on cables used with the instrument.

10 Appendix

This chapter provides addition information on safety, legal and web.

Contents

1	Introduction	9
	Introduction to the System	10
	Physical Layout	12
	Pressure Module	14
	Pump Head	16
	Dual Chamber High Pressure Mixer	20
	Control	23
2	Site Requirements and Specifications	31
	Site Requirements	32
	Physical Specifications	35
	Performance Specifications	36
3	Installation	39
	Installation	40
4	Using the 218 Solvent Delivery Module	41
	Introduction	42
	Power On	43
	Priming the Pump Heads	44
	Creating a Simple Method on an Agilent 218 Pump	45
	Check and Run the Method	46
	Method Menu	48
	Sample Methods	54
5	Optimizing Performance	61
	Choose the Appropriate Pump Head for the Application	62

6	Troubleshooting and Diagnostics	63
	Introduction to Troubleshooting and Diagnostics	64
	Using the Pressure Display as Diagnostic Tool	65
	Troubleshooting Guide	66
7	Maintenance and Repair	73
	Introduction to Maintenance	74
	Warnings and Cautions	75
	Maintenance Schedule	77
	Service Logs	79
	Adjusting the Flow Rate on the Pump	81
	Clearing Air Bubbles from the Liquid Head	82
	Removing Seals (Standard Head)	83
	Removing Seals (Washing Head < 200 mL/min)	85
	Removing seals 200 mL/min Head	87
	Replacing Piston Seals (Heads < 200 mL/min)	88
	Replacing Piston Seals (200 mL/min Head)	90
	Breaking In a New Seal (200 mL/min Head)	92
	Breaking In a New Seal (Heads < 200 mL/min)	93
	Cleaning Check Valves	94
	Replacing Check Valves	96
	Checking and Replacing the Mixer Outlet Filter Frit (Analytical and Narrowbore Mixers Only)	98
	Replacing the Mixer Seal	99
	Checking and/or Changing Power Fuses (F1)	100
	Switching the Mains Voltage	103
8	Parts	107
	Parts List	108
	Liquid Heads	109
	Pressure Modules	110
	Mixer	111
	Standard Accessory Package	112

9 Cables 113

- Cable Overview 114
- Cable Connections 115

10 Appendix 117

- General Safety Information 118
- Solvent Miscibility 124
- Solvent Compressibility 125
- The Waste Electrical and Electronic Equipment Directive 127
- Batteries Information 128
- Radio Interference 129
- Electromagnetic Compatibility 130
- Agilent Technologies on Internet 132

Contents



1 Introduction

Introduction to the System	10
Physical Layout	12
Pressure Module	14
Pump Head	16
Check Valves	18
Dual Chamber High Pressure Mixer	20
Control	23

This chapter gives an instrument overview.



Introduction to the System

A complete modular system includes the pump(s), tubing, mast kit, detector, and optional fraction collector or autosampler.

This manual is set up to help guide you through an Agilent 218 Solvent Delivery Module installation, comprising pressure module, mixer (if ordered) mast kit and tubing.

The Agilent 218 Pump uses proven single-piston rapid-refill technology for economy, reliability, and virtually pulse-free operation. A range of interchangeable pump heads allows operation at flow rates from 10 $\mu\text{L}/\text{min}$ to 200 mL/min . Biocompatible pump heads are available for those analysts requiring a completely inert flow path.

A single-channel analog-to-digital converter built in to each Agilent 218 Pump can convert a detector signal to digital form and transmit the data to a computer system. Five programmable analog inputs and three programmable relay outputs are available to further automate the HPLC system. The Agilent 218 Pump is easy to use and very flexible in operation. It can be used in several different modes of operation: as a standalone isocratic pump, as either a master pump or a slave pump in a high pressure gradient system, as a sample inject pump in a preparative system, or in a fully automated HPLC system controlled by an external computer. In each case, the Agilent 218 Pump provides outstanding accuracy over its entire range of pressures, flow rates, and solvents.

The Agilent 218 Pump operates very quietly because of minimal motor noise and resonance vibrations.

A complete Agilent 218 Pump includes a drive module, a pump head, and a pressure module.

One of the Agilent 218 Pumps in the HPLC system needs to have a pressure module installed in its compartment in the pump side panel. The pressure module dampens pulsations and supplies the current system pressure value to the drive module. Software in the drive module ensures that the system pressure is within pre-set maximum and minimum limits. Flow rates are automatically corrected for solvent-compression effects based on the system pressure value read from the pressure module and a compressibility factor entered by the user for each solvent.

The Agilent 218 Pump operates with a variety of 218 pump heads to maintain specified performance over designated flow and pressure ranges. The easily replaceable pump heads are self-contained units including a spring-loaded piston and check-valve cartridges. Pump heads are not included with individual drive modules.

A complete HPLC system can be controlled either by an Agilent 218 Pump or PC-based software. When the computer controls pumps, all pumps are slaves and programming is done on the computer.

On the pump rear panel there is a single RS-422 male connector. This connector is used for bidirectional signals to and from the controller, whether the controller is an external computer or another Agilent 218 Pump. Internal software in the Agilent 218 Pump determines whether the pump is a master controller or a slave pump.

The possible system configurations (depending on the type of pumps and controller being used) are the following:

- Isocratic system
- Gradient system with one Agilent 218 Pump as the controller

When several pumps are connected together, the master Agilent 218 Pump can control the other pumps in the liquid delivery system. A master Agilent 218 Pump can control up to three other slave units: either three additional pumps in a quaternary system, or two additional elution pumps and one injection pump. The master Agilent 218 Pump can control other modules in the system using outputs, and receive information through input contacts.

- Gradient system with HPLC control software as a controller

In this configuration all pumps are slaves and the computer is the system controller. The HPLC control software controls the pumps via the serial interface cable and other devices through contact closures on the Control/Interface module (CIM) built into the Agilent 218 Pump.

Physical Layout

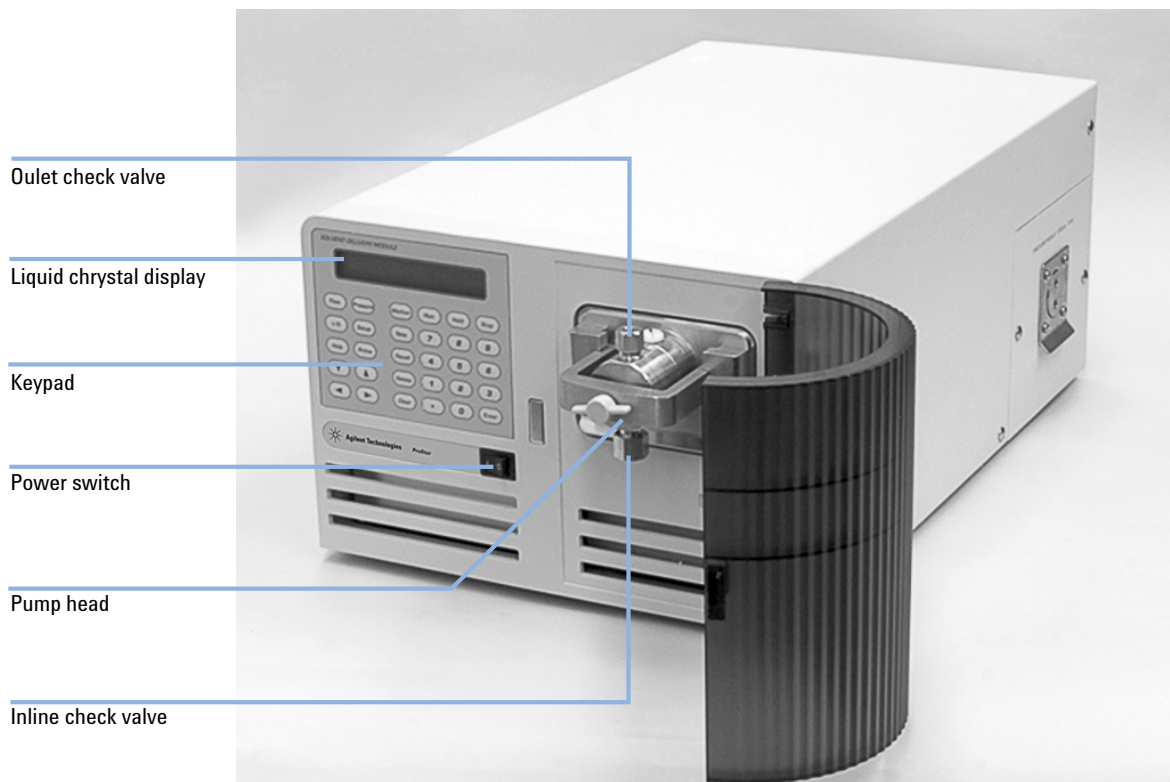

Figure 1 Agilent 218 Solvent Delivery Module – front panel



Figure 2 Agilent 218 Solvent Delivery Module – rear panel

Pressure Module

Each Agilent 218 Pump can have a pressure module installed in the panel on the right side of the pump.



Figure 3 Pressure module

The following pressure modules are available:

p/n	Description
393552501	Pressure module, flow: 10 mL/min, max. pressure rating: 599.84 bar (8700 psi), wetted material: Titanium, FEP
393552801	Pressure module, flow: 10 mL/min, max. pressure rating: 275.79 bar (4000 psi), wetted material: PEEK, FEP
393552601	Pressure module, flow: 50 mL/min, max. pressure rating: 413.69 bar (6000 psi), wetted material: Titanium, FEP
393552901	Pressure module, flow: 50 mL/min, max. pressure rating: 275.79 bar (4000 psi), wetted material: PEEK, FEP
393553001	Pressure module, flow: 100 mL/min, max. pressure rating: 137.9 bar (2000 psi), wetted material: PEEK, FEP

p/n	Description
393552701	Pressure module, flow: 100 mL/min, max. pressure rating: 82.74 bar (1200 psi), wetted material: Titanium, FEP
393650501	Pressure module, flow: 200 mL/min, max. pressure rating: 275.79 bar (4000 psi), wetted material: Titanium, FEP

Only one pump in the HPLC system (the master pump) needs to have a pressure module installed.

The pressure module dampens pump pulsations and supplies the current pressure value to the Agilent 218 pump. The pump needs this information to implement compressibility compensation and flow rate accuracy corrections, and to ensure that system pressure is within the limits entered during setup.

Choose a pressure module that has a pressure and flow limit greater than the maximum pressure and flow you will be using.

Pump Head

Agilent 218 Pump Heads are easily changed, self-contained units including spring-loaded pistons and check valve cartridges.

Simply loosen a finger-tight clamp to rapidly change pump heads between analytical and preparative configurations.



Figure 4 Pump head installed on the pump

NOTE

The clamp on the 218 pump with 200 mL/min head requires a 1/4 in hex wrench that is included with the 200 mL/min pump head kit.

The following pump heads are available:

p/n	Description
R007101061	Pump head, stainless steel, 10 mL/min
R007101062	Pump head, stainless steel, 10 mL/min with piston wash
R007101063	Pump head, titanium, 10 mL/min with piston wash
R007101073	Pump head, PEEK, 10 mL/min with piston wash
393594291	Pump head, titanium, 25 mL/min with piston wash
R007101064	Pump head, stainless steel, 25 mL/min
R007101074	Pump head, PEEK, 25 mL/min with piston wash
R007101076	Pump head, PEEK, 100 mL/min with piston wash
R007101077	Pump head, titanium, 100 mL/min with piston wash
393650701	Pump head kit (218 ONLY), titanium, 200 mL/min

NOTE

These heads incorporate a second chamber located behind the high-pressure seal. This chamber, filled with water, literally *washes* the piston with each stroke. This prevents scale build-up on the piston that can lead to premature seal failure.

Check Valves

The pump head in the Agilent 218 Pump has one inlet check valve and one outlet check valve.

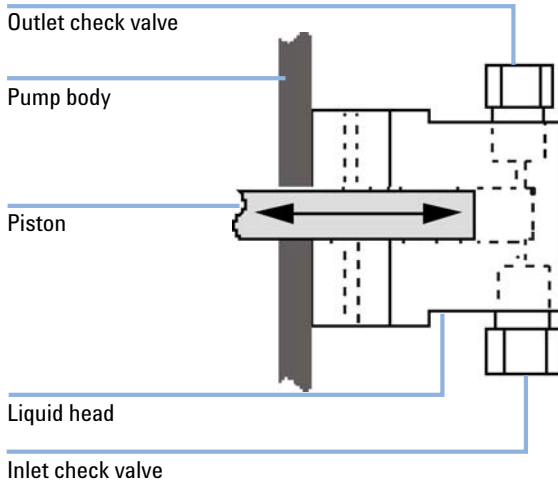

Figure 5 Washing head – cutaway view

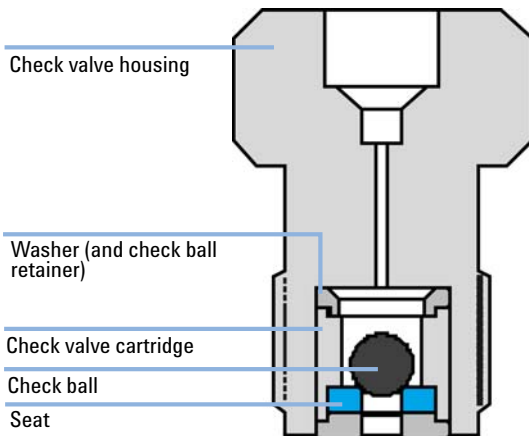

Figure 6 Outlet check valve – sectional view

NOTE

Inlet check valves are similar to outlet check valves but are installed on the liquid head the other way up. Both types of valve the check valve cartridge assembly is oriented as shown.

Principle of Operation

The retracting piston creates a negative pressure in the piston chamber above the inlet check valve. Mobile phase flows upward past the check ball into the inlet check valve, then into the piston chamber.

As soon as the piston starts to move forward, gravity causes the ball in the inlet check valve to seat, preventing mobile phase from flowing back out the inlet check valve. At the same time, a positive pressure is created in the piston chamber which dislodges the outlet check valve check ball. Mobile phase flows upward through the outlet check valve while the piston is moving forward.

When the piston retracts again, gravity causes the ball in the outlet check valve to seat, preventing mobile phase flowing back out the outlet check valve, and the cycle is repeated.

NOTE

During manufacture, each check valve is closely inspected and then individually assembled in a clean-room. Check valves should be kept clean and in good condition for reliable, reproducible flow.

Dual Chamber High Pressure Mixer

Mixers are dual chamber high pressure dynamic mixers designed for binary and ternary gradient HPLC and preparative HPLC systems, see [Figure 7](#) on page 21.

The unique design of the mixer employs a motor-driven magnet oriented perpendicular to the mixing chambers. As the magnet turns, it causes two magnetic stir bars inside the chambers to rotate by radial drive rather than by axial drive as in other dynamic mixers. The close proximity of both stir bars to the rotating drive magnet and the fact that the stir bars rotate in opposite directions ensures continuous and thorough mixing.

A unique piston-type closure on the outlet of the mixer allows easy disassembly without tools for cleaning and maintenance. On analytical and narrowbore mixers the piston incorporates a 2 μm solvent filter to protect system components from contamination.

The mixer is designed to be plumbed into an HPLC system between the pumps and the injection valve.

Titanium and PEEK mixers are available for applications where 316 stainless steel may be inappropriate because of corrosion or release of metal ions into solution. Titanium or PEEK plumbing components can be used together with PEEK tubing to provide a totally iron-free fluid path.

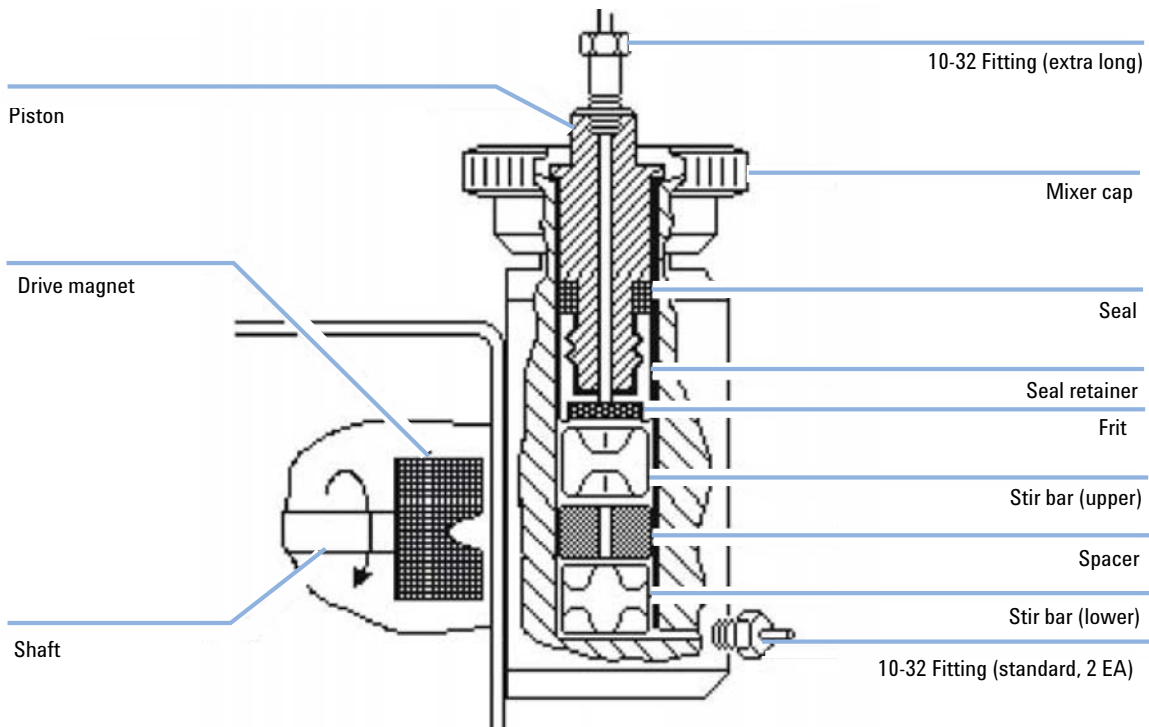

Figure 7 Section view of analytical mixer body

Solvents from the pumps enter the mixer via the two inlet ports at the base of the mixer body. They flow into the lower mixing chamber, where they are mixed by the rotation of the lower stir bar. The pressure from the pumps forces the mixed mobile phase upward through the spacer into the upper mixing chamber, where additional mixing is performed by the opposite rotation of the upper stir bar. The fully mixed mobile phase is then forced through a 2 μm frit (in analytical and narrowbore mixers), through the piston, and out to the rest of the HPLC system.

Since the spacer (the stir bar cage on preparative mixers) assures isolation between the two mixing chambers, the mixer acts as a two-stage filter for solvent composition noise. It is more effective in averaging and reducing solvent composition noise than a single-chamber mixer of equivalent volume.

The passive seal used in the mixer is a hollow molded plastic ring with a circular groove containing an energizing spring. The side of the seal containing the spring faces into the mixer chambers. When the mixer is unpressurized,

1 Introduction

Dual Chamber High Pressure Mixer

the small spring inside the seal maintains contact with the mixer bore and the piston with enough force to seal at low pressures, but not excessive force to prevent the seal from sliding as the mixer cap is hand-tightened. When pressurized, mobile phase enters the mixer body and presses the seal against the mixer bore and the piston. The increased force maintains sealing action at HPLC pressures.

The inlet ports on the analytical and narrowbore mixers accept standard 10-32 fittings. The outlet port uses an extra-long 10-32 fitting. On the preparative scale, both inlet and outlet ports accept 1/4-28 fittings for 0.318 cm (1/8 in) tubing.

Effective sealing in the mixer is a function of the passive sealing mechanism only. The sealing action cannot be improved by tightening the cap with more force than can be applied by hand.

Control

NOTE

This section is only applicable to LC systems that are controlled by the 218 Solvent Delivery Module as master controller.

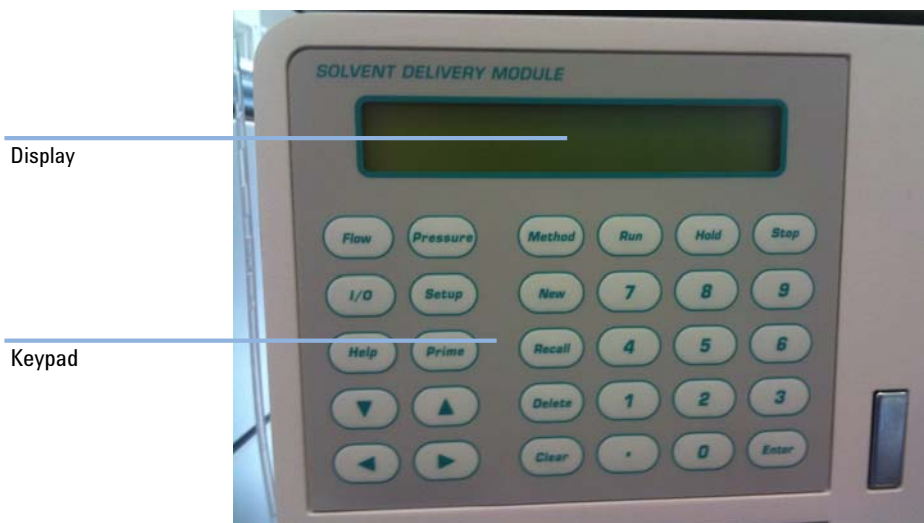

Displays

The left and right arrows at the sides of the display indicate that more information is off screen and can be accessed by pressing either the left arrow key or the right arrow key. You can scroll left or right through the off-screen information by repeatedly pressing the key.

Cursors

In the Agilent 218 displays, parameters which can be edited are indicated by one of four types of cursor. All types of cursors flash both sides of the parameter to be edited. Each type of cursor has a specific function.

Table 1 Specific cursor functions

Cursor	Name	Function
--	NUMERIC ENTRY CURSOR	Used for numeric entry only. Values entered or edited while the cursor is flashing are temporary until accepted by pressing the ENTER key, the RIGHT ARROW key, the LEFT ARROW key, or the RUN key. If the edited value is not accepted by pressing one of the above keys, or cancelled by pressing the CLEAR key, the parameter reverts to its previous value after 60 seconds.
↓↑	SCROLL CURSOR	Used when there is a preset list of choices. Pressing the UP ARROW or the DOWN ARROW with this type of cursor is displayed scrolls up or down through the preset choices.
??	DUAL-MODE CURSOR	Used when there is a preset list and numeric entry. Used when the value can be set either by numeric entry or by scrolling through a preset list of choices, as described above.
	MENU CURSOR	Used when the selection is a menu. Pressing the DOWN ARROW or the ENTER key with this type of cursor displays the next level of the menu.

NOTE

The following are not cursors, but are described here for clarity.

*	ASTERISK	Used to show cursor position (for accessing HELP) when the parameter in question is a status indicator and cannot be edited.
←→	LEFT-RIGHT ARROWS	These indicators are used at the right or left edge of the display to indicate that more information can be seen by pressing either the RIGHT or LEFT ARROW key.

Keypad

The keypad is functionally divided into four groups:

- Function keys,
- Method keys,
- Control keys, and
- Edit keys.

Table 2 Function keys

Key	Function
Flow	<p>This key opens the FLOW window where you can set flow rate and ramp time. The window also shows system pressure. The left and right arrows at the sides indicate that you can access more information with the left-right arrow keys:</p> <p>Method status and name to the left. Current values for composition for %B, %C, %D to the right. Also I/O parameters.</p> <p>You can reach more information to the right in two ways:</p> <ul style="list-style-type: none">• Press the right arrow to scroll rightward through the entire line.• Press the I/O button below. (The entire line of information is divided between the FLOW and I/O buttons for convenience. "time" is always displayed.)

NOTE

Pressing the FLOW key when in another display returns the display to the part of the Flow field which was last viewed. Pressing the FLOW key a second time returns to the default position, with the cursor on the flow rate value.

Table 2 Function keys

Key	Function
I/O	This key opens the second part of the display. Note that you can scroll leftward into the Flow section if you wish. The I/O section contains the following items, from left to right:
Analog	Analog Input. This is the current voltage read on the Analog input channel for this pump only. Range from -0.5 V to +2.5 V.
ishtm	Input Contact Status. Contacts are: Inject, Stop, Hold, Transfer and Mark. "1" indicates a closed contact, "0" indicates an open contact.
Meth	Method status and name (repeat information from Flow display above).
nm	This control is used to set wavelength on a suitable detector when the analog out signal has been set to the "nm" option in Setup or there is a detector online. Range is 1.90 V (190 nm) to 7.00 V (700 nm).
w	Inject Wait. When a method is running, this is used to set an inject wait. The method will hold at current conditions until the wait is cancelled, when the method will continue. The wait can be cancelled manually by pressing the RUN key or by contact closure on the Inject input.
A	Alarm. Can be set to "1" (on), "0" (off), or "P" (Pulse on then off). If Pulsed, the alarm will sound three times then off. If set to Pulse at the same time as an inject wait, the alarm sounds four times, then off. Otherwise the alarm sounds continuously until turned off.
1 - 12	Output contacts. Can be set to "0" (off), "P" (Pulse on then off), "1" (on), or "P" (Pulse off then on). Pulses last for 0.5 s. Contacts 1–3 are for Pump A or the Master Pump in a multi-pump configuration. The Master Pump can control the outputs as follows: <ul style="list-style-type: none"> • Contacts 1, 2, 3 are for Pump A or the Master Pump. • Contacts 4, 5, 6 are for Pump B. • Contacts 7, 8, 9 are for Pump C. • Contacts 10, 11, 12 are for Pump D. One or two contacts can be dedicated for High and Low Pressure signals, defined in the pressure window below. Pressure States are H for High, L for Low, or b for both, if the same contact is used for high and low limits.
NOTE	
Pressing the I/O key when in another display returns the display to the part of the I/O field which was last viewed. Pressing the I/O key a second time returns to the default position, with the cursor on "nm".	

Table 2 Function keys

Key	Function
PRESSURE	Opens the PRESSURE window containing several pressure-related items.
ZERO	The pressure can be zeroed using the up/down arrow key. Executing a Zero command displays a prompt. When system pressure is more than 50 psi, a second prompt with current pressure is displayed.
psi/bar/MPa	Current system pressure is shown in the selected units.
MAX P	Maximum system pressure limit, in the units selected.
MIN P	Minimum system pressure limit, in the units selected.
UNITS	Select between psi, bar, and MPa (mega Pascals).
OUTPUT CONTACTS	Set the output contacts to be used for MAX P and MIN P signals.

NOTE
The same contact can be set for both high limit and low limit.

Table 2 Function keys

Key	Function
SETUP	Opens the Set Up and Service Log menus. The Service Log is used to log piston seal changes, check valve changes/service intervals, and show the pump drive status. See the Maintenance section for details of this function. The Set Up menu appears in one of two forms, depending on whether the Agilent 218 is a master controller or a slave pump. In both cases, Set Up is used to set up various parameters listed below: <i>As Slave Pump:</i>
ID	Pump ID. Set the ID for the Agilent 218 either by entering a number between 0 and 63, or pressing the UP ARROW or DOWN ARROW key to scroll through a preset list of choices. Available choices are: 0–63, MC (master controller) or – (no ID).
HdSz	Pump head size. Use the UP ARROW or DOWN ARROW to select between a preset list of choices. Choices are: 5, 10, 25, 50, 100, and 200 (mL/min), 10P, 25P, 50P, 100P. The “P” designation stands for PEEK. The compressibility compensation for PEEK heads is different than for stainless steel or titanium heads.
x	Compressibility Factor. This is used to calculate the flow rate compensation necessary to correct for the solvent’s compressibility. Values can be set between 0 – 2000 Mbar ⁻¹ . Default of 46 is the setting for water. The parameter can be adjusted to set the measured flow rate at exactly the set flow rate. See “ Adjusting the Flow Rate on the Pump ” on page 81 for details on how to do this. Other solvents will have different x parameters. See “ Solvent Compressibility ” on page 125 for a list of values for other solvents.
L	High Pressure Constant. Range is from 1 – 9999 bar. Default is 3231 bar, the value for water. Consult the available literature for high pressure constants for other solvents. A partial list is given in “ Solvent Miscibility ” on page 124.
REFILL	Refill time in milliseconds. Refill time is the time required for the piston return stroke. Range is from 100 – 1000 ms.
CIM	Control-Interface Module ID. Set the ID for the CIM installed in the pump either by entering a number between 0 and 63, or pressing the UP ARROW or DOWN ARROW key to scroll through a preset list of choices. Can be set between 0 and 63, or to – (no ID).
	<i>As Master Controller:</i>
AOut	Analog Out. 0 – 10 V output signal with 8 options. Output can be sent to a detector (to control wavelength) or to a recording device. Options are: Flow, nm (wavelength), Pres(sure), %A, %B, %C, %D, or off.
PUMPS	Select between A, B, C, and D. Selecting a pump opens a window to set Pump ID, Head size, compressibility factors, and refill speed.
Detr	Sets the ID number for any detector connected to the serial cable.
Bus Status	Shows the status of serial devices. The display shows ID numbers of devices and active devices at any of the IDs. Identifiers are “B, C, D, or P” for Pump, “M” for Detector, “I” for CIM, and “E” for Error.
BUS IDs	Identifies devices defined on the serial bus with their model number, ID number, and status (online or offline) device IDs of some remote devices may be changed in this window.

Table 3 Method keys

Key	Function
METHOD	Displays method information. Pressing the METHOD key opens a window where you can see the status of the running method and scroll through a list of existing methods. Method Status codes are:
V	View. Indicates that the method in the display is not running.
I	Initialization. The displayed method is ramping to time 0 (inject time).
R	Running. The displayed method is running (beyond time 0).
S	Stop. The displayed method is stopped, and flow rate = 0, by the STOP key or external input, or by the method finishing with 0 mL/min flow rate.
H	Hold. The displayed method is holding. Either the HOLD key was pressed, an Inject Wait programmed, or an external input was received.
F	Finished. The method has run and finished normally with flow rate ? 0.
	For non-manual methods the Agilent 218 displays a list of method parameters, which can be accessed by scrolling with the RIGHT ARROW and LEFT ARROW keys:
Meth	This shows the Method name and status (see above).
PASS	Indicates the current method pass (if there are more than one).
#TIMES	Indicates the total number of times (up to 99) that the method will be executed before it finishes.
Access	method will be executed before it finishes. Access User can scroll between LOCK and UNLOCK. Locked methods cannot be edited. They are saved intact and when running Locked methods ignore the HOLD key.
Transfer	Lets you set a method to be transferred to in one of three ways: <ul style="list-style-type: none"> • immediately on receipt of a Transfer contact closure input • at the end of the current method pass on receipt of a Transfer input • automatically on completion of all the method passes
Safety	Allows you to assign a safety method for any of the following conditions: <ul style="list-style-type: none"> • Stop input • High Pressure Limit • Low Pressure Limit • Pump Off-line
RECALL	Returns the pump to the current status timeline of the running method. The fields displayed in this view are the same as were displayed the last time the FLOW or I/O key was pressed in the running method. When on the current time line RECALL returns to the last display viewed.

1 Introduction

Control

Table 3 Method keys

Key	Function
HELP	Opens a Help display for the parameter which is selected. In most cases, the help information is longer than will fit a two-line display. <ul style="list-style-type: none">• Scroll through the help message by pressing the HELP key, the RIGHT ARROW key, or the DOWN ARROW key.• Scroll back through the Help message by pressing the UP ARROW or the LEFT ARROW key.• Press the CLEAR key or the HELP key at the end of the message to exit the Help.
L-R Arrows	These keys are used to move right and left in the display to access adjacent menus and to set values.
U-D Arrows	These keys are used to scroll up or down through preset values or toggle between choices. They are also used to select time lines in a method. The Down Arrow key is also used to open menus.
ENTER	The Enter key is used to open menus. It also is used to accept a value.

Table 4 Control Keys

Key	Function
RUN	Starts the method timer and begins a linear ramp from current conditions to the target conditions at the next time line in the method. If used to clear a Hold, (see below) RUN continues the run from the HOLD point.
HOLD	Stops the method timer but does not change current flow or composition conditions. Holds the ramp at its current position. This key is cancelled by pressing RUN again or STOP.
PRIME	Runs the pump at the maximum flow rate for the installed pump head. Pressing STOP stops the pump when it is priming. All other keys are locked out from operation while the pump is priming.
STOP	Stops flow immediately and aborts the Run method.

Table 5 Edit keys

Key	Function
0–9, and .	Numeric keys, used to enter numeric values into parameters: method number, flow rate, minimum and maximum pressure limits, pump ID, CIM ID, etc.
CLEAR	Used to cancel a user-entered value or choice, leaving the previously entered setting intact. Also used when zeroing pressure, answers "No" to prompts and clears messages.
U-D Arrows	Used to scroll through a list of options and select an item from the list.
ENTER	Accepts a temporary value into a parameter. Answers "Yes" to prompts.



2 Site Requirements and Specifications

Site Requirements	32
Physical Specifications	35
Performance Specifications	36

This chapter provides information on environmental requirements, physical and performance specifications.



Site Requirements

Power Considerations

The instrument power supply has wide ranging capability. It accepts any line voltage in the range described in *Physical Specifications*.

WARNING

Hazard of electrical shock or damage of your instrumentation can result, if the devices are connected to a line voltage higher than specified.

→ Connect your instrument to the specified line voltage only.

CAUTION

Inaccessible power plug.

In case of emergency it must be possible to disconnect the instrument from the power line at any time.

→ Make sure the power connector of the instrument can be easily reached and unplugged.

→ Provide sufficient space behind the power socket of the instrument to unplug the cable.

Power Cords

Different power cords are offered as options with the module. The female end of all power cords is identical. It plugs into the power-input socket at the rear. The male end of each power cord is different and designed to match the wall socket of a particular country or region.

WARNING

Absence of ground connection or use of unspecified power cord

The absence of ground connection or the use of unspecified power cord can lead to electric shock or short circuit.

- Never operate your instrumentation from a power outlet that has no ground connection.
 - Never use a power cord other than the Agilent Technologies power cord designed for your region.
-

WARNING

Use of unsupplied cables

Using cables not supplied by Agilent Technologies can lead to damage of the electronic components or personal injury.

- Never use cables other than the ones supplied by Agilent Technologies to ensure proper functionality and compliance with safety or EMC regulations.
-

WARNING

Unintended use of supplied power cords

Using power cords for unintended purposes can lead to personal injury or damage of electronic equipment.

- Never use the power cords that Agilent Technologies supplies with this instrument for any other equipment.
-

Bench Space

The module dimensions and weight (see [Table 6](#) on page 35) allow you to place the module on almost any desk or laboratory bench.

It needs an additional 5 cm (2 in) of space on either side and approximately 15 cm (5.9 in) at the rear for air circulation and electric connections.

If the bench shall carry a complete HPLC system, make sure that the bench is designed to bear the weight of all modules.

The module should be operated in a horizontal position.

Condensation

CAUTION

Condensation within the module

Condensation will damage the system electronics.

- Do not store, ship or use your module under conditions where temperature fluctuations could cause condensation within the module.
 - If your module was shipped in cold weather, leave it in its box and allow it to warm slowly to room temperature to avoid condensation.
-

Physical Specifications

Table 6 Specifications Agilent 218 Purification Solution

Type	Specification
Rated voltage	100 – 240 VAC (90 – 264 Absolute), 50 – 60 Hz The Agilent 218 Purification Solution ¹ may be wired for either: <ul style="list-style-type: none"> • 115 V ±10 % , 50 /60 Hz single phase • 230 V ±10 % , 50 /60 Hz single-phase
Weight	23.6 kg(52.0 lb)
Dimensions (height x width x depth)	197 x 292 x 464 mm (7.8 x 11.5 x 18.3 in)
Line voltage	115 – 230 V ±10 %
Line frequency	50 – 60 Hz
Power consumption	550 VA
Ambient operating temperature	3 – 40 °C
Humidity	20 – 80 %
Operating altitude	up to 2000 m The 218 System Pump is suitable for indoor use only and is classified Pollution degree 2 and Installation Category II (EN 61010-1).

¹ All power supplies should be single phase AC, 3 wire system (active, neutral, ground) and should be terminated at an appropriate connection receptacle that is within reach of the system power cable.

Performance Specifications

Table 7 Performance specifications Agilent 218 Purification Solution

Type	Specification
Display	Backlit LCD with 2 lines, 48 characters
Programs	Up to 100 methods with unlimited timed events
Interface	<ul style="list-style-type: none">• Digital serial input/output channel (RS-422)• 3 programmable contact-closure relay outputs• 5 contact-closure inputs• 1 analog input (-0.5 V to +2.5 V), 18-bit A/D converter• 1 programmable analog output (0 – 10 V)
Flow Accuracy	1 % of selected flow rate or 0.05 % of maximum flow, whichever is larger (0.1 % for 5 mL/min heads)
Flow Reproducibility	0.1 % of selected flow or 0.05 % of maximum flow, whichever is larger (0.01 % for 5 mL/min heads)
Connections	<ul style="list-style-type: none">• 1/4-28 inlet flanged or gripper-type fitting• 1/4-28 outlet for nut and ferrule
Fluid Path	316 stainless steel, titanium, sapphire or ceramic, ruby, PCTFE, PTFE, or HDPE

Table 8 Pressure limits pump heads

Nominal flow (mL/min)	Range (mL/min)	SST and Titanium (pressure maximum)	PEEK (pressure maximum)
10	0.01 – 10	8700 psi 600 bar 60.0 MPa	4000 psi 275 bar 27.6 MPa
25	0.025 – 25	6000 psi 414 bar 41.4 MPa	4000 psi 275 bar 27.6 MPa
100	0.1 – 100	4000 psi 275 bar 27.6 MPa	2000 psi 137 bar 13.8 MPa
200	0.2 – 200	3500 psi 241 bar 24.1 MPa	N/A

2 Site Requirements and Specifications

Performance Specifications

Table 9 Performance specifications pressure modules

Description/wetted materials	Inlet fittings (in)	Outlet fittings (in)	Max. pressure (psi)	Max. flow rate (mL/min)
10 mL/min , Titanium, FEP	¼-28	¼-28	8700	10
50 mL/min , Titanium, FEP	¼-28	¼-28	6000	50
100 mL/min , Titanium, FEP	¼-28	¼-28	1200	100
10 mL/min , PEEK, FEP	¼-28	¼-28	4000	10
50 mL/min , PEEK, FEP	¼-28	¼-28	4000	50
100 mL/min , PEEK, FEP	¼-28	¼-28	2000	100
200 mL/min , Titanium, FEP	¼-28	¼-28	400	200 ¹

¹ Uses 0.318 cm (1/8 in.) ID tubing.



3 Installation

Installation 40

This chapter gives information about the installation of your instrument.



Installation

For details on installation of the module, refer to Agilent 218 Purification System – Setup and Installation Guide (G9300-90301).



4

Using the 218 Solvent Delivery Module

Introduction	42
Power On	43
Priming the Pump Heads	44
Creating a Simple Method on an Agilent 218 Pump	45
Check and Run the Method	46
Method Menu	48
Sample Methods	54

This chapter explains the operational parameters of the instrument.



Introduction

The Agilent 218 Purification Solution can be used in several different modes of operation, including operation as a master pump in an automated HPLC system. This section explain how to use the LC system if the 218 pump is configured as master controller. If your LC system is controlled by OpenLAB CDS ChemStation as master controller, please refer to the OpenLAB CDS online help system.

NOTE

If the equipment is used in a manner not specified by the manufacturer, the protection provided by the equipment may be impaired.

Power On

- 1 Press the power switch on the module.

The Agilent 218 pump will perform a self-check and display the screens below in the order shown.

Solvent Delivery System Version x.x
--

Version x.x Self Test RAM...

Self Test Ram OK Pressure Module 8700 psi
--

Appropriate pressure rating will be shown.

S	time	mL/min	psi
<	0.00	0.00	0 >

Priming the Pump Heads

Pump heads are shipped dry. IPA, methanol or HPLC grade water is recommended for priming the pump heads and pre-wetting the seals.

Tools required

Description

Syringe

Preparations

Pump head size entered, see *Setting the Pump ID and Pump Head Size* in Agilent 218 Purification System – Setup and Installation Guide (G9300-90301).

- 1 Remove the outlet tubing and fitting from the outlet check valve.
- 2 Use the syringe supplied to prime the pump head. Attach the Luer fitting to the outlet check valve. Attach the priming syringe to the outlet of the Luer fitting.
- 3 Press the **PRIME** key.
This will run the pump at the maximum flow rate for that pump head.
- 4 Using the syringe, pull the solvent through the inlet tubing and the pump head.
- 5 Once the pump is primed, press the **STOP** key to stop the pump.
- 6 Remove the Luer fitting from the outlet check valve and replace it with the outlet tubing.

Creating a Simple Method on an Agilent 218 Pump

The following method will ramp an Agilent 218 Pump to 5 mL/min in 2 minutes to time 0.00. At time 0.00, the pump will wait for inject and Alarm; make the injection, and maintain flow rate at 5 mL/min for 5 minutes. After 5 minutes, the flow rate will ramp to 0 mL/min over 5 minutes. Use a pump head size of 10 mL or greater for this method.

- 1 Press the **METHOD** key.
- 2 Press the **NEW** key (a new method number will be selected and displayed automatically). The method number displayed will be the next available number from 0 to 99.
- 3 Press the **FLOW** key.
- 4 The starting time is shown in minutes (default is -2.00). If this is not displayed, press **2**, **ENTER**. This is the time for the linear ramp to initial conditions.
- 5 Press the **DOWN ARROW** key to get to time 0.00.
- 6 Press the **RIGHT ARROW** key to move to the **FLOW** field. Press 5 (flow rate of 5 mL/min.)
- 7 Press the **I/O** key then the **RIGHT ARROW** key to get to the **w** field. Press the **UP ARROW** key with the cursor on the **w** field. The value changes to **1** (ON).
- 8 Press the **RIGHT ARROW** key to get to the **A** field. Press the **DOWN ARROW** key. The value changes to **P** (Pulse on then off).
- 9 Press the **FLOW** key then the **LEFT ARROW** key to get to the Time field.
- 10 Press the **NEW** key.
- 11 Press **5** to set a time of 5 minutes.
- 12 Press the **RIGHT ARROW** to get to the **FLOW** field and press **5**.
- 13 Press the **NEW** key and then press **1**, **0**, then **ENTER**.
- 14 Press the **RIGHT ARROW** key and then **0**, **ENTER**.

Check and Run the Method

- 1 Press the **LEFT ARROW** key until you are at the **Time** field then press the **UP ARROW** key a number of times to read through the method time lines.
- 2 Press the **DOWN ARROW** key to scroll down through the time lines.
- 3 Press the **RUN** key to begin this method.

You will see the time field counting down and the flow rate counting up, to reach 5 mL/min at time zero. Then you will hear the alarm at time 0, indicating there is an inject wait.

NOTE

If you were performing an actual run, the inject wait would be cancelled by a contact closure from either the manual injection valve or an autosampler. In this case, cancel it as follows:

- Press the **RUN** key to clear the **HOLD**. This will act as an injection signal in this demonstration method.

The method will continue to run its course, ramping from 0 to 5 mL/min over 2 minutes, and then maintaining 5 mL/min until 5 minutes, finally ramping down to zero flow rate at 10 minutes.

METHOD EDITING: DIAGRAMMATIC FORM

```

Meth
V MM
NEW Meth 0 COPY OF Meth 0 PASS 0 #TIMES 1 ACCESS TRANSFER SAFETY MODE
LOCK UNLOCK METH METH NORMAL
LEARN DEMO
Meth TRANSFER MODE Meth STOP HIGH P LOW P OFF-LINE
V 0 -- -- V 0 -- --
V starting time
-2.00
V min mL/min psi %B %C %D %E Analog ishtm Meth nm w A 1 2 3 4 5 6 7 8 9 10 11 12
0.00 5.00 0 0 0.0000 00000 V 0 1 P P 1
V min mL/min psi %B %C %D %E Analog ishtm Meth nm w A 1 2 3 4 5 6 7 8 9 10 11 12
5.00 5.00 0 50 0.0000 00000 V 0 P
V min mL/min psi %B %C %D %E Analog ishtm Meth nm w A 1 2 3 4 5 6 7 8 9 10 11 12
10.00 5.00 0 50 0.0000 00000 V 0 0
V min mL/min psi %B %C %D %E Analog ishtm Meth nm w A 1 2 3 4 5 6 7 8 9 10 11 12
15.00 5.00 0 75 0.0000 00000 V 0
V min mL/min psi %B %C %D %E Analog ishtm Meth nm w A 1 2 3 4 5 6 7 8 9 10 11 12
20.00 5.00 0 75 0.0000 00000 V 0
V min mL/min psi %B %C %D %E Analog ishtm Meth nm w A 1 2 3 4 5 6 7 8 9 10 11 12
25.00 5.00 0 100 0.0000 00000 V 0
V min mL/min psi %B %C %D %E Analog ishtm Meth nm w A 1 2 3 4 5 6 7 8 9 10 11 12
30.00 5.00 0 100 0.0000 00000 V 0
V min mL/min psi %B %C %D %E Analog ishtm Meth nm w A 1 2 3 4 5 6 7 8 9 10 11 12
45.00 0.00 0 0 0.0000 00000 V 0
  
```

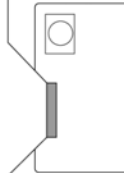

- Press METHOD key.
- Press NEW key. Set general method parameters.
- Set Transfer and Safety Method information as required.
- Press FLOW key. Set time for ramp to initial conditions.
- Press Down Arrow for time 0.00. Set initial conditions. (Flow = 5 mL/min). Set contact closures.
- Press NEW key, then number key(s), for new timeline and new conditions. (Ramp to 50%B). Repeat for new timeline. (10 min. Hold at 50%B).
- Repeat for new timeline. (15 min. Ramp to 75%B).
- Repeat for new timeline. (20 min. Hold at 75%B).
- Repeat for new timeline. (25 min. Ramp to 100%B).
- Repeat for new timeline. (30 min. Hold at 100%B).
- Repeat for new timeline. (45 min. Ramp to 0 mL/min. 0 %B).

Figure 8 Method editing: diagrammatic form

Method Menu

Display the Main Method display

- 1 Press the **METHOD** key then the **NEW** key.

The **Main Method** display is visible.

New Meth	COPY OF Meth	PASS	#TIMES	ACCESS	TRANSFER	SAFETY	MODE
0	--	0	1	UNLOCK	Meth	Meth	NORMAL
				LOCK			DEMO
				Meth	TRANSFER	MODE	
			V 0	--	IMMED	DEFER	
				Meth	STOP	HIGH P	LOW P
				V 0	--	--	OFF-LINE
							--

Figure 9 Main Method display

NOTE

You will not see all this information at once, but can access the off-screen portion of the display with the **RIGHT ARROW** key. The **DOWN ARROW** is used to select menu choices, such as **ACCESS**: its choices are **UNLOCK** and **LOCK**.

NOTE

The **TRANSFER** and **SAFETY** method sub-menus are also shown. These sub-menus are used to specify which method is to be used when there is a Transfer or Stop signal received by the pump and are also opened by pressing the **DOWN ARROW** key.

NOTE

The **New** status and **COPY OF Meth** appear only when you press the **New** key. Once a method is created, these items do not appear in the display.

Preparing Creating a Method

- 1 Press the **METHOD** Key

The default method display is open.

```
Meth
S MM
```

Figure 10 Default method display

This display shows that the Agilent 218 Purification Solution is in **Manual Method** status, the default state which allows you to operate the pump manually by entering flow values and pressing the **RUN** key. Cursors around **MM** are used to select between **EXISTING** methods.

NOTE

The first time you open this display these cursors will be inoperable, as there are no methods programmed yet.

2 Press the **NEW** key.

New Meth	COPY OF	Meth	PASS	#TIMES	ACCESS	TRANSFER	SAFETY	MODE
0	-		0	1	UNLOCK	Meth	Meth	NORMAL

Creating a New Method

The cursors around the method number (0 in this case) will be flashing. This means that you can select a method number for your new method.

1 Press the desired number key(s).

OR

Press the **UP ARROW** or **DOWN ARROW** key to scroll through the available (unused) method numbers.

OR

Access the default number.

The first time you do this, all methods from 0–99 will be selectable. However, if you have methods already created, you will not be able to select or enter allocated method numbers.

If you enter a number with the keys that is already used, you will get the message:

```
INVALID
METH:xx EXISTS
```

NOTE

You can create up to 99 methods. This may seem like overkill, but is useful when there are multiple users in a lab: Specialized methods, such as Transfer methods or Safety methods, could be allocated from 90–99.

Examples on how to use this feature:

- Analyst A could use methods from 20–29, and Analyst B from 40–49.
- Specialized methods, such as Transfer methods or Safety methods, could be allocated from 90–99.

Copying Methods

The Agilent 218 Purification Solution allows you to duplicate an existing method. This is useful if you want to create a new method with the same or similar conditions as an existing method. Perhaps you wish to change only a single parameter or condition.

- 1 Press the **RIGHT ARROW** key to reach the **COPY OF Meth** field and then use the **UP ARROW** or **DOWN ARROW** to scroll through a list of existing method numbers.

OR

If you already know the method you wish to duplicate, enter the number with the number keys.

Display PASS

This is not editable, but is a display of the current pass (if more than one) of the method.

- 1 See **#TIMES**, step 1 on page 50.

Set #TIMES

- 1 Use the **LEFT ARROW** or **RIGHT ARROW** key to move to the **#TIMES** field.
- 2 Enter the number of times you wish the method to execute before stopping.
When the method is running, the **PASS** field will increment for each time the method executes.

Set the ACCESS level

This field lets you set the access level, or status of the method.

- 1 Use the **LEFT ARROW** or **RIGHT ARROW** key to move to the **ACCESS** field.
- 2 Choose between **UNLOCK** and **LOCK**.

NOTE

Unlocked methods can be edited and changed, even while running. Locked methods cannot be edited and the steps are protected from change. The **Hold** key will be ignored when a Locked method is running.

Assign a TRANSFER Method

- 1 Use the **LEFT ARROW** or **RIGHT ARROW** key to move to the **TRANSFER Meth** field.
- 2 Press the **DOWN ARROW**.

Meth	TRANSFER	MODE
V 0	-	IMMED
		DEFER

Figure 11 Sub-Menu to set transfer method

- 3 Set the method to be transferred in the event of a TRANSFER signal to the Agilent 218 or automatically at the end of the method if no transfer signal is received.

NOTE

If you do not wish the method to transfer, leave this entry blank.

- 4 Use the **UP ARROW** or **DOWN ARROW** key to scroll between existing method numbers.
OR
Enter the method number with the number keys.
- 5 Under the **MODE** field, use the **UP ARROW** or **DOWN ARROW** key to select between **IMMED**(iate) or **DEFER**(ed).

NOTE

- If you choose **IMMED**, the transfer function will occur immediately on receipt of the transfer contact closure.
- If you choose **DEFER**, the transfer will take place at the end of the current method pass IF a transfer contact closure is received.
- If there is no transfer contact closure received, the method will transfer automatically at the end of all method passes.

- 6 Press the Method key to leave this sub-menu and return to the Method Menu.

Assign a SAFETY Meth

Set the method to be transferred to in the event of an emergency condition or contact closure to the Agilent 218 Purification Solution.

- 1 Use the **LEFT ARROW** or **RIGHT ARROW** key to move the cursor on **SAFETY METH**.
- 2 Press the **DOWN ARROW** key.

Meth	STOP	HIGH P	LOW P	OFF-LINE
V 0	-	-	-	-

- 3 Select between the available methods for each field with the **UP ARROW** or **DOWN ARROW** key.

OR

Enter the method number with the number keys.

Table 10 Safety methods

Setting	Use case
STOP	Used to set the method to be used in the event of a STOP signal to the Agilent 218 Purification Solution. The current method will stop and transfer to the selected method. If there is no STOP method selected the pump will abort the running method and stop.
HIGH P	Used to set the method to be used in the event of a High Pressure condition (High Pressure Limit, or Max Pressure, is set in the Pressure menu). The current method will stop and transfer to the selected method. If there is no HIGH P method selected the pump will transfer to the Stop Safety method, if one is specified, otherwise it will simply stop when the High Pressure Limit is reached.

Table 10 Safety methods

Setting	Use case
LOW P	Used to set the method to be used in the event of a Low Pressure condition (Low Pressure Limit, or Min Pressure, is set in the Pressure menu). The current method will stop and transfer to the selected method. If there is no LOW P method selected the pump will transfer to the Stop Safety method, if one is specified, otherwise it will simply stop when the Low Pressure Limit is reached.
OFF-LINE	Used to set the method to be used in the event that one of the other pumps in the system goes OFF-LINE . The current method will stop and transfer to the selected method. If there is no method selected the Agilent 218 will transfer to the Stop Safety method, if one is specified, otherwise it will simply stop if another pump goes OFF-LINE.

NOTE

If you do not wish the method to transfer, leave this entry blank.

- 4 Press the **Method** key to leave this sub-menu and return to the Method Menu.

Assign a MODE

In NORMAL mode the master pump will operate normally and respond to pressure, flow and compositional information from the other pumps in the HPLC system. DEMO mode is useful for method development. This mode allows you to create and run methods which control other pumps, without those pumps being physically present. Also, a single-pump demo method can be run without the pump operating; the display will indicate the changing conditions, current time, flow rate, etc., but the drive mechanism will not engage.

- 1 Use the **LEFT ARROW** or **RIGHT ARROW** key to move to the **MODE** field.
- 2 Select between **NORMAL** or **DEMO**.

Sample Methods

The following pages contain sample methods and a blank method sheet.

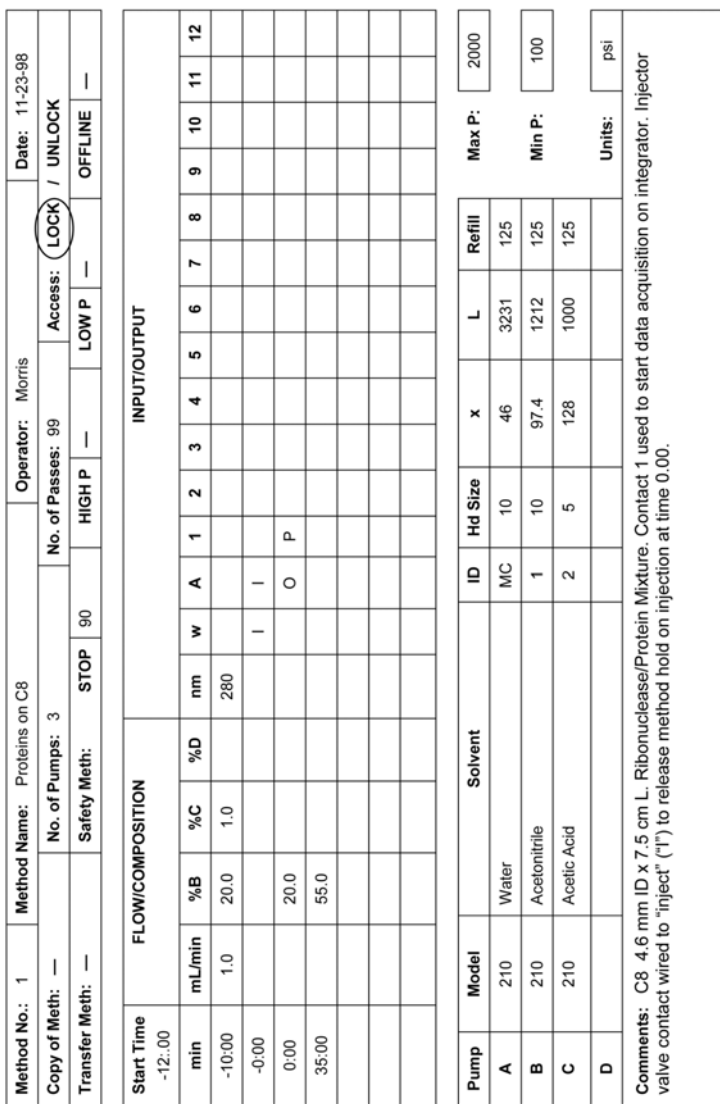

Figure 12 Proteins on C8

4 Using the 218 Solvent Delivery Module Sample Methods

Method No.: 2		Method Name: Aromatic Hydrocarbons		Operator: French		Date: 11-24-98	
Copy of Meth: —		No. of Pumps: 2		No. of Passes: 99		Access: LOCK / UNLOCK	
Transfer Meth: 40		Safety Meth: STOP		90		HIGH P — LOW P — OFFLINE —	

FLOW/COMPOSITION				INPUT/OUTPUT																
Start Time	mL/min	%B	%C	%D	nm	w	A	1	2	3	4	5	6	7	8	9	10	11	12	
-2:00																				
min	3.00	75.0			254															
-1:00																				
0:00																				
1:00																				
1:40																				
4:00																				

Pump	Model	Solvent	ID	Hd Size	x	L	Refill
A	210	Water	MC	10	46	3231	125
B	HPXL	Acetonitrile	1	10	97.4	1212	125
C							
D							

Max P: 2000
Min P: 50
Units: psi

Comments: C18, 3 µm, 4.6 mm ID x 10 cm L. Contact 1 – start autosampler. Contact 2 – run chart recorder from 0-4 minutes.

Figure 13 Aromatic hydrocarbons

Method No.: 3		Method Name: AAAanalysis				Operator: Ward				Date: 11-25-98			
Copy of Meth: --		No. of Pumps: 2		No. of Passes: 99		Access: LOCK / UNLOCK							
Transfer Meth: 40		Safety Meth: STOP		90		LOW P		HIGH P		OFFLINE		--	

FLOW/COMPOSITION						INPUT/OUTPUT																
Start Time	min	mL/min	%B	%C	%D	nm	w	A	1	2	3	4	5	6	7	8	9	10	11	12		
-15:00																						
	-10:00	1.00	0.0		340																	
	-0:00		0.0				I	P														
	45:00		80.0																			

Pump	Model	Solvent	ID	Hd Size	x	L	Refill	Max P:
A	210	95% 0.1M Na Acetate pH 7.2 4.5% MeOH 0.5% THF	MC	10			125	3000
B	210	MeOH	1	10			125	Min P: 50
C								
D								Units: psi

Comments: Microsorb AAAanalysis, Type O w/guard

Figure 14 AA Analytics

4 Using the 218 Solvent Delivery Module Sample Methods

Method No.: 40	Method Name: Standby	Operator: Burce	Date: 11-23-98																
Copy of Meth: --	No. of Pumps: 2	No. of Passes: 1	Access: LOCK / UNLOCK																
Transfer Meth: --	Safety Meth: STOP	HIGH P --	LOW P --	OFFLINE --															
FLOW/COMPOSITION																			
Start Time	mL/min	%B	%C	%D	nm	w	A	1	2	3	4	5	6	7	8	9	10	11	12
-2:00	0:10	0					I												
INPUT/OUTPUT																			
Pump	Model	Solvent	ID	Hd Size	x	L	Refill	Max P:											
A																			
B								Min P:											
C																			
D								Units:											
Comments: Ramp flow to 0.1 mL/min. Sound alarm indefinitely when autosampler runs out of vials on AAAAnalysis routine.																			

Figure 15 Standby

Method No.: 90	Method Name: Stop	Operator: Lewis	Date: 11-24-98
Copy of Meth: —	No. of Pumps: 3	No. of Passes: 1	Access: LOCK / UNLOCK
Transfer Meth: —	Safety Meth: STOP	HIGH P: —	LOW P: —

FLOW/COMPOSITION										INPUT/OUTPUT											
Start Time	mL/min	%B	%C	%D	nm	w	A	1	2	3	4	5	6	7	8	9	10	11	12		
-0:00	0.0						I			I											

Pump	Model	Solvent	ID	Hd Size	x	L	Refill	Max P:
A								
B								Min P:
C								
D								Units:

Comments: Immediate ramp to 0 mL/min. Alarm sounds continuously. Contact 3 used to shut-down autosampler.

Figure 16 Stop

4 Using the 218 Solvent Delivery Module Sample Methods

Method No.:	Method Name:				Operator:				Date:														
Copy of Meth:	No. of Pumps:				No. of Passes:				Access: LOCK / UNLOCK														
Transfer Meth:	Safety Meth:				HIGH P				LOW P OFFLINE														
Start Time												INPUT/OUTPUT											
FLOW/COMPOSITION																							
min	mL/min	%B	%C	%D	nm	w	A	1	2	3	4	5	6	7	8	9	10	11	12				
Pump	Model	Solvent		ID	Hd Size	x	L	Refill	Max P:														
A																							
B									Min P:														
C																							
D									Units:														
Comments																							

Figure 17 Blank

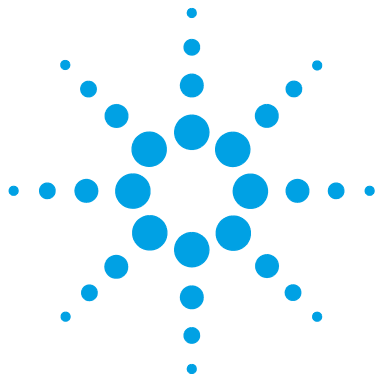

5 Optimizing Performance

Choose the Appropriate Pump Head for the Application [62](#)

This chapter gives hints on how to optimize the performance or use additional devices.



Choose the Appropriate Pump Head for the Application

Choose from standard pump heads providing flow rates up to 10, 25, 100, or 200 mL/min.

Single Pump Operation

Ideally, for single pump operation, the flow rate should be between 5 % and 90 % of the maximum pump head flow rate.

Examples:

- 10 mL/min pump head for applications requiring between 0.5 – 9 mL/min
- 100 mL/min pump head should be used for applications requiring between 5 – 90 mL/min

NOTE

The pump head can be used at its fully specified range but a 10 mL/min pump head will operate at 1 mL/min better than a 100 mL/min pump head.

Gradient Applications

Choosing the best pump heads for gradient applications is slightly different.

If possible, choose the pump head so that the system operates at or above 10 % of the minimum pump head flow rate. Also try to use the smallest pump head possible for gradient operation.

Protein Purification Applications

Biocompatible pump heads constructed entirely of titanium or chemically inert plastics are available.

These heads incorporate a second chamber located behind the high-pressure seal. This chamber, filled with water, literally *washes* the piston with each stroke. This prevents scale build-up on the piston that can lead to premature seal failure.



6 Troubleshooting and Diagnostics

Introduction to Troubleshooting and Diagnostics 64

Using the Pressure Display as Diagnostic Tool 65

Troubleshooting Guide 66

This chapter gives an overview about the troubleshooting and diagnostic features.



Introduction to Troubleshooting and Diagnostics

Troubleshooting an HPLC system requires a methodical approach to be effective.

To correct a given problem, proceed step-by-step, eliminating each variable in turn before moving to the next. Some problems have more than one cause, and can be difficult to locate and correct. The troubleshooting guide lists some common pump and HPLC system symptoms, with possible causes and suggested corrective actions.

In most cases, you will be able to correct the problem. However, sometimes the symptom will remain after you have tried the corrective action. In these cases, please contact your local Agilent office.

Using the Pressure Display as Diagnostic Tool

The sensitivity of the pressure display is within 68.9 kPa (10 psi). The pressure display can be used as a diagnostic tool. Following issues cause characteristic pressure fluctuations in HPLC systems (parameters valid for HPLC operating at normal pressure):

- Zero to several hundred kPa: Bubbles in the solvent
- 68.9 – 275.8 kPa Sticking check valve

HINT

If fluctuations > 68.9 kPa try to eliminate bubbles in the solvent (see [“Clearing Air Bubbles from the Liquid Head”](#) on page 82).

If this does not solve the problem, a check valve is probably sticking. It may be possible to rectify this problem by cleaning the check valve (see [“Cleaning Check Valves”](#) on page 94).

Troubleshooting Guide

Troubleshooting Guide

The troubleshooting guide is divided into sections, related to symptoms observed in the following units:

- Electronics
- Liquid flow system
- Detector signals

Electrical Symptoms

Pump Dead

Table 11 Pump dead

Probable cause	Solution
Power cord disconnected	Plug in power cord
Power switched off	Switch power on
Fuse dead	Replace fuse

External Symptoms of Liquid Flow System

Leaks

Table 12 Leaks

Probable cause	Suggested actions
Loose fitting(s)	Tighten all plumbing connections no more than 1/4 turn past finger-tight.
Worn ferrule or fitting	Replace fitting and ferrule.
Damaged seal	Replace seal.
Loose check valve	Tighten 1/16 turn past the leak-point.
Incorrect fitting(s)	Reconnect with correct fittings.

No flow or pressure

Table 13 No flow or pressure

Probable cause	Suggested actions
Pump is not operating	<ol style="list-style-type: none"> 1 Plug in power cord 2 Switch pump on 3 Check fuses and replace if necessary
Air in pump	<ol style="list-style-type: none"> 1 Disconnect outlet fittings 2 Degas solvent. 3 Divert flow to waste and pump at a high flow rate to prime pump.
Clogged solvent inlet filter	Check and replace if necessary.

Low flow

Table 14 Low flow

Probable cause	Suggested actions
Pump is pressure limiting	Reset MIN P setting to higher value.
Clogged solvent inlet filter	Check and replace if necessary.
Drain valve leaking	Repair leak in drain valve.

Excessive pressure, restricted flow

Table 15 Excessive pressure, restricted flow

Probable cause	Suggested actions
Tubing clogged/ partly clogged	Crack all fittings one by one until the pressure reverts to normal. Then replace the section of tubing immediately after the last cracked fitting.
Injection valve clogged	Flush injection valve, replace sample loop. If this does not clear the blockage see the injection valve manual.
Injector between LOAD/INJECT	Reposition to LOAD or INJECT.
Frit (filter) in column clogged	Replace the column frit.
Detector flow cell clogged	Attach a syringe to the flow cell inlet and try to clear blockage by drawing on the syringe. Or attach to outlet and back-flush to clear blockage by gentle pressure on the syringe. Do not apply pressure to the flow cell inlet.

Erratic pressure

Table 16 Erratic pressure

Probable cause	Suggested actions
Leak	Check and repair leaks.
Air in pump	<ol style="list-style-type: none"> 1 Disconnect outlet fittings. 2 Degas solvent. 3 Divert flow to waste and pump at a moderately high flow rate to prime pump.

Air bubble in tubing

Table 17 Air bubble in tubing

Probable cause	Suggested actions
Loose inlet tubing connection	Tighten inlet fittings.
Worn flange in inlet tubing	Remake inlet tubing flange.
Loose inlet check valve	Tighten 1/16 turn past the leak-point.
Inlet filter partially clogged	Clean or replace.
Loose outlet tubing connection	Tighten outlet fittings.

Excessive backpressure

Table 18 Excessive backpressure

Probable cause	Suggested actions
Clogged mixer frit	Replace frit ¹
Stir bar/spacer sticking	<ul style="list-style-type: none"> • Dismantle and clean mixer • Filter solvents • Check solvent miscibility
Blocked tubing	Loosen fitting after each component to find blockage. Replace affected tubing.
Damaged ferrule in compression fitting	Replace ferrule. Do not over-tighten.

¹ Analytical and narrowbore mixers only.

Detection Symptoms

Noisy baseline

Table 19 Noisy baseline

Probable cause	Suggested actions
Air bubbles through flow cell	<ul style="list-style-type: none">• Install backpressure regulator• Divert flow to waste and pump at a moderately high flow rate to prime pump• Check tubing fittings• Degas solvent
Leak in system plumbing	Check for deposits around fittings and check that all fittings are tight.
Contaminated flow cell	Attach a syringe to the flow cell inlet and try to clear blockage by drawing on the syringe. Or attach to outlet and back-flush to clear blockage by gentle pressure on the syringe. Do not apply pressure to the flow cell inlet.
Detector lamp failing	Check and replace if necessary.
Bad grounding	Check all grounding connections on pump and ensure grounded AC power is supplied to all devices in HPLC system.
Electronic interference	<ul style="list-style-type: none">• Check for loose connections• Ensure instruments are not in direct contact with each other or with vibrating parts
Localized temperature effects	<ul style="list-style-type: none">• Wrap tubing, column• Remove or cover heat or cooling source

Drifting baseline

Table 20 Drifting baseline

Probable cause	Suggested actions
Contaminated flow cell	Attach a syringe to the flow cell inlet and try to clear blockage by drawing on the syringe. Or attach to outlet and back-flush to clear blockage by gentle pressure on the syringe. Do not apply pressure to the flow cell inlet.
Localized temperature effects	<ul style="list-style-type: none"> • Wrap tubing, column • Remove or cover heat or cooling source
Contamination in column	<ul style="list-style-type: none"> • Wash or replace column • Change mobile phase
Leak in system	Locate leak and repair.
Bubble trapped in flow cell	<ul style="list-style-type: none"> • Flush flow cell • Degas solvent • Add back-pressure device to flow cell
Column not equilibrated	Flush system until column is equilibrated.
Mobile phase contamination	Use fresh HPLC-grade solvents.
Weak detector lamp	Replace detector lamp.

Flat-top peaks

Table 21 Flat-top peaks

Probable cause	Suggested actions
Saturated electronics	Reduce sample volume.
Recorder adjusted incorrectly	Set recorder correctly.
Bad grounding	Check all grounding connections on pump and ensure grounded AC power is supplied to all devices in HPLC system.

Baseline spikes

Table 22 Baseline spikes

Probable cause	Suggested actions
Air bubbles through flow cell	<ul style="list-style-type: none">• Degas solvent• Pump to waste at a moderately high flow rate to prime pump• Check tubing fittings
Bad connections	Check all grounding connections on pump and ensure grounded AC power is supplied to all devices in HPLC system.
Electronic interference	<ul style="list-style-type: none">• Check for loose connections.• Ensure instruments are not in direct contact with each other or with vibrating parts.
Electrical equipment in circuit cycling on and off	Isolate equipment which cycles on and off to a different circuit.



7 Maintenance and Repair

Introduction to Maintenance	74
Warnings and Cautions	75
Maintenance Schedule	77
Service Logs	79
Adjusting the Flow Rate on the Pump	81
Clearing Air Bubbles from the Liquid Head	82
Removing Seals (Standard Head)	83
Removing Seals (Washing Head < 200 mL/min)	85
Removing seals 200 mL/min Head	87
Replacing Piston Seals (Heads < 200 mL/min)	88
Replacing Piston Seals (200 mL/min Head)	90
Breaking In a New Seal (200 mL/min Head)	92
Breaking In a New Seal (Heads < 200 mL/min)	93
Cleaning Check Valves	94
Replacing Check Valves	96
Checking and Replacing the Mixer Outlet Filter Frit (Analytical and Narrowbore Mixers Only)	98
Replacing the Mixer Seal	99
Checking and/or Changing Power Fuses (F1)	100
Switching the Mains Voltage	103

This chapter describes the maintenance of the instrument.



Introduction to Maintenance

The pumps have been carefully designed with continuous, unattended operation in mind. Rugged construction and sophisticated electronics mean a minimum of routine maintenance and years of trouble-free service if treated carefully and if replacement parts are changed when they show signs of wear. This section of the manual describes a maintenance schedule, service logs, changing the piston seals, changing the check valve cartridges and changing the mixer seals and frits.

You should take advantage of the Service Logs. Software in the pump automatically tracks seal wear, check valve use, and pump drive wear. The software also allows the user to enter and record seal and check valve changes. Make it a point to check the Service Log area frequently and make sure to record seal changes and check valve replacements into the software.

Warnings and Cautions

WARNING

Toxic, flammable and hazardous solvents, samples and reagents

The handling of solvents, samples and reagents can hold health and safety risks.

- When working with these substances observe appropriate safety procedures (for example by wearing goggles, safety gloves and protective clothing) as described in the material handling and safety data sheet supplied by the vendor, and follow good laboratory practice.
 - The volume of substances should be reduced to the minimum required for the analysis.
 - Do not operate the instrument in an explosive atmosphere.
-

WARNING

Electrical shock

Repair work at the module can lead to personal injuries, e.g. shock hazard, when the cover is opened.

- Do not remove the cover of the module.
 - Only certified persons are authorized to carry out repairs inside the module.
-

WARNING

Personal injury or damage to the product

Agilent is not responsible for any damages caused, in whole or in part, by improper use of the products, unauthorized alterations, adjustments or modifications to the products, failure to comply with procedures in Agilent product user guides, or use of the products in violation of applicable laws, rules or regulations.

- Use your Agilent products only in the manner described in the Agilent product user guides.
-

7 Maintenance and Repair

Warnings and Cautions

CAUTION

Safety standards for external equipment

- If you connect external equipment to the instrument, make sure that you only use accessory units tested and approved according to the safety standards appropriate for the type of external equipment.
-

Maintenance Schedule

User maintenance on the Agilent 218 Pump is generally limited to the pump head, as follows:

- Cleaning the check valves and filter.
- Replacing components subject to wear and tear: piston seals, check valves, piston assembly, seal back-up, return spring.

Continuous, unattended operation is common with HPLC components. A general guideline for the replacement frequency of consumable components is indicated in the table below. The table assumes the pump is working at half its maximum flow rate and pressure. Replacement frequency is indicated for intensive, regular, and occasional pump use.

The solvent used also effects replacement frequency. Mobile phases with buffers and high ionic strength will cause the seals to fail more frequently.

Table 23 Frequency of component replacement

Component/Use	Intensive (168 hrs/wk)	Regular (40 hrs/wk)	Occasional (10 hrs/wk)
Piston seal	4–6 months	1 year	2 years
Check valves	6–12 months	2 years	4 years
Piston assembly	1–2 years	4–6 years	8–10 years
Seal back-up	1–2 years	4–6 years	8–10 years
Return spring	2 years	4–6 years	8–10 years

NOTE

This table is only a guideline; pump head components may need to be replaced more or less often than indicated.

Changes in performance, or visible leaks, give more precise indication that a part should be replaced.

Seals need to be replaced every so often. This is because friction from the moving pistons eventually abrades the seal and pressurized liquid in the piston chamber seeps past the seal. Seal wear may be indicated by leaks from

7 Maintenance and Repair

Maintenance Schedule

the notch at the bottom of the liquid head, although this sign may not be present if the solvent leak evaporates quickly.

Seal wear is accelerated under adverse conditions, such as pumping at high flow rates or pressures, using aggressive or aqueous solutions, or dirty or contaminated mobile phase. Moderate operation (low flow, low pressure, organic solutions, and fresh clean HPLC-grade mobile phases) will result in longer seal life. However, every seal will eventually need replacing. Software in the Agilent 218 Pump allows you to both check the seal wear and to log when the seals are changed. Your pump uses either a standard liquid head or a washing liquid head.

Service Logs

Agilent 218 software automatically tracks seal wear, check valve use, and pump drive wear. The software also allows the user to enter and record seal and check valve changes.

Use the Service Logs

- 1 Press the **SETUP** key to open the **SETUP / SERVICE** log display.
- 2 Press the **RIGHT ARROW** to reach Service Log and then press the **DOWN ARROW** to see the following display.

PISTON	CHECK	PUMP
SEAL	VALVE	DRIVE

- 3 Select the desired menu by pressing the **RIGHT** or **LEFT ARROW** key.

Table 24 Piston Seal Log

Item	Function
SL LOG (Seal Log)	Displays the sequential number of last seal change.
DATE	Date of last seal change service. This value is entered numerically by the user.
USE	Use units since last seal change, proportional to number of strokes and pump pressure.
LIMIT	Use units limit set by user, depending on anticipated amount of use.
CHGD (Changed)	Press the DOWN ARROW then the ENTER key to enter YES when seal change is performed.

Table 25 Check Valve Log

Item	Function
CK LOG	Sequential number of the last check valve service (check valve cartridge replacement).
DATE	Date of last check valve service. This value is entered numerically by the user.

Table 25 Check Valve Log

Item	Function
USE	Use units since last check valve service.
LIMIT	Use units set by user, depending on anticipated amount of use.
IO (Inlet/Outlet)	Press the UP or DOWN ARROW keys to scroll between the choices to indicate the check valve. The check valve is referenced in the next menu item (CHGD). Scrollable choices are:
IO YY	Serviced both check valves
IO NY	Serviced the outlet check valve, but not the inlet check valve
IO YN	Serviced the inlet check valve, but not the outlet check valve
CHGD (Changed / Serviced)	Press the DOWN ARROW then the ENTER key to enter YES when check valve cartridge replacement (the only check valve user-service item) is performed.

Table 26 Pump drive

Item	Function
WEAR FACTOR	This indicates wear in the drive. Both the pump pressure and the flow rate are recorded by the Agilent 218 software and factored into this indicator.
KCYLS	This is the number of piston strokes recorded by the pump software divided by 1000.
HRS	Cumulative operational hours recorded by the pump software.

Adjusting the Flow Rate on the Pump

The flow rate can be adjusted using the compressibility compensation parameters.

One may achieve this by applying pressure to the pump, using a column, a long piece of small diameter analytical tubing or a restrictor valve.

When Operational qualification

Tools required

Description

Restriction (column, small diameter tubing or restrictor valve)

Flow meter, volumetric flask or balance

- 1 Flush the system with water. (If you want to adjust the flow rate using a different solvent, flush the system with that solvent.)
- 2 Enter the values for the compressibility compensation for water (or whatever solvent you are using to adjust the flow rate). Using the **SETUP** key and adjust the **x** value to **46** and the **L** value to **3231**. (For a different solvent, use the compressibility values provided in [Table 29](#) on page 125.)
- 3 Put a restriction into the flow path that provides between 2000 psi (13.8 MPa) and 3000 psi (20.7 MPa) pressure. This can be a column, a long piece of small diameter tubing or a restrictor valve.
- 4 Set the flow rate to 1 mL/min (for the 5 or 10 mL pump heads) and whatever flow is normally used for larger pump heads and start the pump. Allow the pressure to come to equilibrium.
- 5 Measure the flow rate accurately using either a calibrated flow meter, a calibrated volumetric flask or by weighing solvent on a calibrated balance.
- 6 If the measured flow rate is higher than the set flow rate, lower the value of the **x** parameter. To raise the actual flow rate, increase the value of the **x** parameter. For water, an increase or decrease of about 20 will lower the flow rate about 0.5 % to 1 %. For other solvents, the **x** parameter adjustment value will vary.
- 7 Continue to adjust the **x** parameter until the actual flow rate falls within the pump specification of ± 1 % of the set flow rate.

Clearing Air Bubbles from the Liquid Head

If you notice pressure fluctuations from zero to several hundred kPa when the HPLC system is operating at normal pressure, there is probably a bubble in the liquid head.

WARNING

Chemical burns to eyes, skin, and/or respiratory tract

The mobile phases in the system may be hazardous.

- Observe all standard laboratory safety precautions.
- Always wear personal protective equipment.

- 1 Operate the pump at moderate flow (10 % of maximum) with the system pressurized.
- 2 Carefully loosen the outlet check valve fitting; just enough to make it leak (also known as *crack the fitting*).

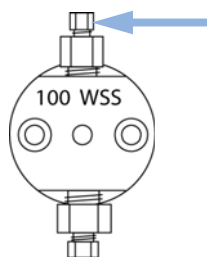

Figure 18 Outlet check valve fitting

You should see solvent sputtering at the fitting as the bubble leaks past the fitting.

- 3 When the bubble is clear, the sputtering will stop and the solvent will ooze past the fitting. At this point tighten the fitting.

Removing Seals (Standard Head)

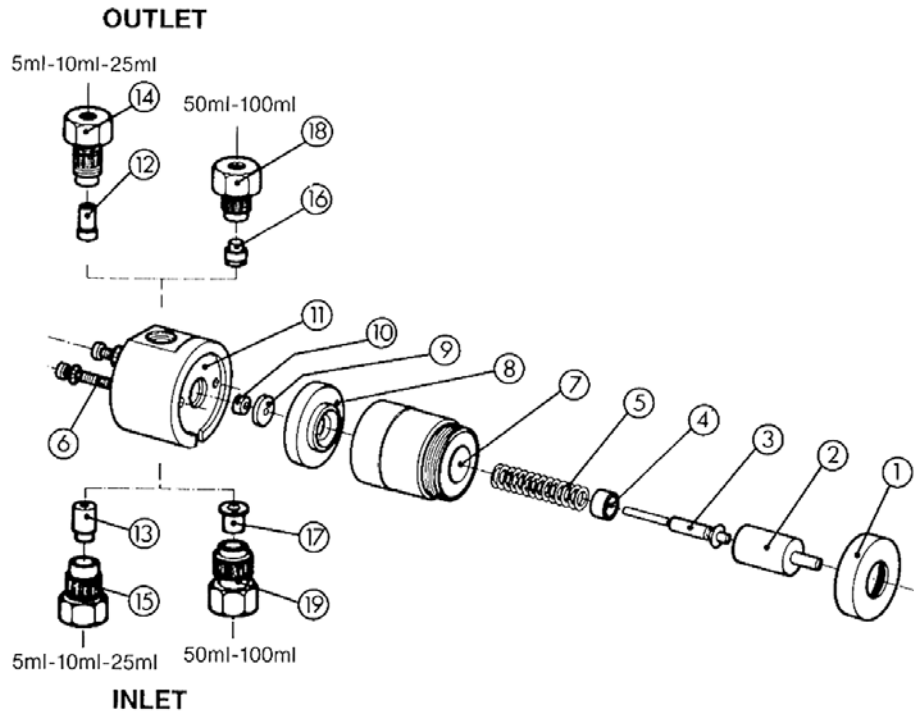

Figure 19 Standard pump head (exploded view)

1	Threaded cap
2	Piston cup
3	Piston assembly
4	Piston guide
5	Return spring
6	Screws
7	Bearing housing

7 Maintenance and Repair

Removing Seals (Standard Head)

8	Housing spacer
9	Seal backup
10	Piston seal
11	Liquid head
12	Outlet check valve cartridge
13	Inlet check valve cartridge
14	Outlet check valve housing
15	Inlet valve housing
16	Outlet check valve cartridge
17	Inlet check valve cartridge
18	Outlet check valve housing
19	Inlet valve housing

Tools required

Description

3 mm wrench

- 1 Make sure the pump is stopped and switch off the power switch.
- 2 Remove the fittings at the inlet and outlet check valves.
- 3 Loosen the head clamp nut and remove the head clamp.
- 4 Pull the pump head straight out from the pump body.
- 5 Disassemble the pump head:
 - a Unscrew the threaded cap (1).
 - b Remove the piston cup (2), piston assembly (3), piston guide (4), and return spring (5).
 - c Loosen the two screws (6) at the front of the pump head. Remove the bearing housing (7) and the housing spacer (8).
 - d Remove the seal backup (9).
- 6 Carefully remove the seal (10). If the seal is stuck, pry it out carefully so that the liquid head (11) is not scratched.

NOTE

Do not reuse a seal after it has been removed.

Removing Seals (Washing Head < 200 mL/min)

Two identical piston seals are incorporated into each washing head: one in the head body and one in the washing section. Each piston seal consists of a seal ring made from high-density polyethylene (HDPE) and a spring made of Hastelloy®-C276. Both piston seals should be replaced at the same time.

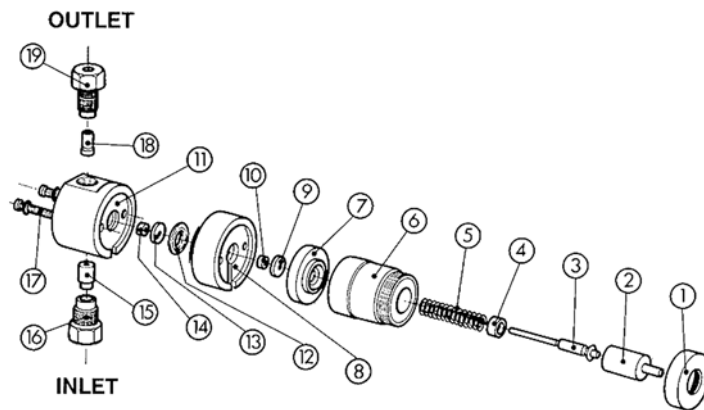

Figure 20 Washing head (exploded view)

1	Threaded cap
2	Piston cup
3	Piston assembly
4	Piston guide
5	Return spring
6	Bearing housing
7	Housing spacer
8	Washing section
9	Seal backup
10	Piston seal

7 Maintenance and Repair

Removing Seals (Washing Head < 200 mL/min)

11	Liquid head
12	O-ring
13	Seal backup
14	Piston seal
15	Inlet check valve cartridge
16	Inlet check valve support screw
17	Screw
18	Outlet check valve cartridge
19	Outlet check valve support screw

Tools required

Description

3 mm wrench

- 1 Make sure the pump is stopped and switch off the power switch.
- 2 Remove the fittings at the inlet and outlet check valves.
- 3 Loosen the head clamp nut and remove the head clamp.
- 4 Pull the pump head straight out from the pump body.
- 5 Disassemble the pump head:
 - a Unscrew the threaded cap (1).
 - b Remove the piston cup (2), piston assembly (3), piston guide (4), and return spring (5).
 - c Loosen the two screws (17) at the front of the pump head and remove the bearing housing (6) and the housing spacer (7).
 - d Remove washing section (8), o-ring (12), and seal backups (9, 13).
- 6 Carefully remove the seals (10, 14). If the seals are stuck, pry them out carefully so that the liquid head (11) or washing section (8) is not scratched.

NOTE

Do not reuse a seal after it has been removed.

Removing seals 200 mL/min Head

Tools required	Description
	1/4 in hex wrench
	3 mm wrench

- 1 Turn off power to the pump.
- 2 Remove pump head clamp by loosening the hex screw with 1/4-in. hex wrench.
- 3 Lift off clamp and pull pump head out of the housing.
- 4 Unscrew the threaded cap (see [Figure 19](#) on page 83) and remove all parts possible from this side of the head.
- 5 Before loosening the two hex head screws draw a line the length of the pump head body using a marker pen. This line will make it easier to have all of the parts in the correct orientation during reassembly. Loosen and remove the two 3 mm hex head screws and separate all of the parts.

- 6 Place the liquid head with both inlet and outlet check valves plugged.



- 7 Fill the cylinder cavity half full with HPLC-grade water. Insert the ceramic piston into the cavity through the piston seal.



- 8 Push down on the piston. The piston seal will pop out onto the piston.

NOTE

When the seal pops out a small amount of water is sprayed out, so use an area appropriate for this procedure.



Replacing Piston Seals (Heads < 200 mL/min)

Preparations

The necessary seal tools come as part of the pump head kit.

Piston, seal, and seal location are clean, undamaged, and completely free from foreign matter.

- 1 Place the guide on the head or rinse body with the beveled side facing out.
- 2 Insert the new seal into the guide with spring down.
- 3 10 and 25 mL/min heads: Press the seal into place using the seal tool.

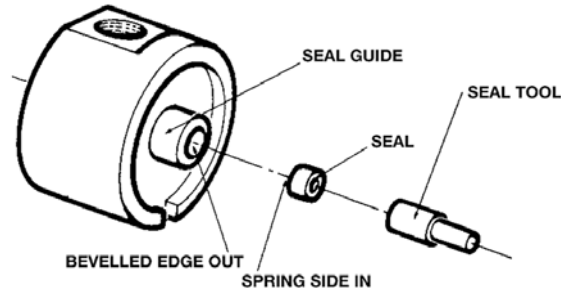

Figure 21 Seal replacement for 10 and 25 mL/min heads

OR

100 mL/min head: Press the seal into place using the seal tool.

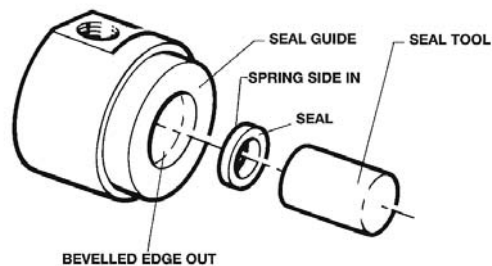

Figure 22 Seal replacement for 100 mL/min heads

Replacing Piston Seals (Heads < 200 mL/min)

- 4 Reassemble the head by reversing the directions for seal removal, noting the following:
 - Align the ball housing assembly, the housing spacer, the rinse body (for washing heads) and the head body so the matching hole or notch is on the same side on each component.
 - Thread the ball housing assembly, the housing spacer, and the rinse body (for washing heads) to the head body. After these parts are attached, put the assembly on a flat surface to facilitate mounting the other parts.

Replacing Piston Seals (200 mL/min Head)

Preparations

The necessary seal tools come as part of the pump head kit.

Piston, seal, and seal location are clean, undamaged, and completely free from foreign matter.

- 1** Before installing a new piston seal make sure you are installing the piston seal and not the washing section seal.

Piston seal

Washing section seal

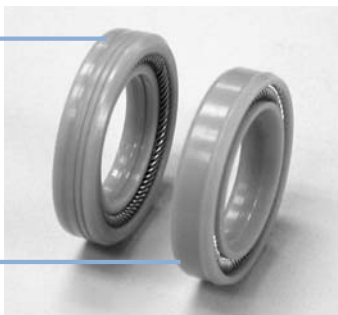

NOTE

The piston seal has ridges on its edge.

- 2** Put the seal insertion tool (with protruding ring down) into liquid head and make sure it is flush against the liquid head.



- 3** Place the piston seal (spring side down) in the seal insertion tool with the spring side of the seal down.

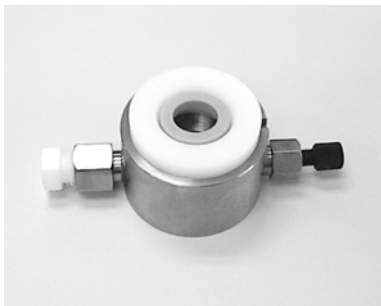

- 4** Place the seal plunger tool on top of the seal and press the seal into place.



- 5 Remove seal insertion tools and reassemble the pump head following [Figure 20](#) on page 85 and the ink mark which was placed on the pump head body before disassembly (see [“Removing seals 200 mL/min Head”](#) on page 87).

NOTE

Before use, break in the seal using a 100 % methanol.

7 Maintenance and Repair

Breaking In a New Seal (200 mL/min Head)

Breaking In a New Seal (200 mL/min Head)

When

After seal replacement

- 1 Install a 60 – 90 cm (2 – 3 ft) length of 0.25 mm (0.010 in) ID PEEK or stainless steel tubing downstream from the pump, which will create backpressure.
- 2 Use 100 % methanol at 25 mL/min for 5 – 10 min.

NOTE

You can recycle the methanol back into the supply reservoir.

Breaking In a New Seal (Heads < 200 mL/min)

When After seal replacement

To maximize the life of new seal

- 1 Run the pump without backpressure for 1 – 2 min at 20 % of nominal flow rate with 100 % methanol.
- 2 Plumb a column (or tubing or restrictor that causes approximately 13.8 MPa (2000 psi) and 20.7 MPa (3000 psi) pressure) into the HPLC system and run the pump at normal operating pressure for 5 – 10 min, checking for any leaks.
- 3 Repeat Step 1 for 30 minutes.

The seal will now be ready for normal operation.

Cleaning Check Valves

A pressure drop may indicate that one of the check balls has become coated with gummy or particulate matter or that a small particle has become lodged on the seat; in either case the check ball will not seat correctly and pressure will be lost. It may be possible to rectify this problem using isopropanol to dissolve the foreign matter.

When Occasionally, especially in case of drop in backpressure.

Cleaning Check Valves with Isopropanol

- 1 Disconnect the outlet tubing and connect a line to a waste bottle.
- 2 Check miscibility of solvent in the pump head with isopropanol.
- 3 Isopropanol and solvent in pump head miscible: Pump isopropanol in the pump head
OR
Isopropanol not miscible with solvent in the pump head:
 - 1 Pump an intermediate solvent in the pump head (see “[Solvent Miscibility](#)” on page 124)
 - 2 Pump isopropanol in the pump head.
- 4 With the pump head filled with isopropanol, stop the flow for approximately 15 min to dissolve deposits.
- 5 Flush the isopropanol from the head and return to operating conditions. (Using an intermediate solvent if necessary.)

Cleaning Check Valves with 20 % Nitric Acid

If the above cleaning procedure does not restore normal performance, you can try using 20 % nitric acid to dissolve the deposits.

1 Remove the check valve from the pump head.

WARNING

Chemical burns to eye, skin and respiratory tract

A 20 % nitric acid solution is a strong acid. Strong acids are extremely corrosive and pose severe risks.

→ Observe all standard laboratory safety precautions when using strong acids.

→ Always wear appropriate personal protective equipment.

2 Soak check valve in 20 % nitric acid for ten minutes.

3 Carefully remove the check valve from the acid bath and rinse thoroughly with deionized water.

4 Reinstall the check valve on the pump head.

NOTE

If this procedure fails to correct the problem you should replace the check valve as described in [“Replacing Check Valves”](#) on page 96.

Replacing Check Valves

Check valve failure may be indicated by a severe loss in flow rate. However, a leaking piston seal can also result in low flow rate and is more common than check valve failure. Inspect for a leaking seal before replacing the check valve.

Tools required

Description

Appropriately sized open ended wrench (delivered with the pump head).

Preparations

Pump head is already removed.

CAUTION

Damage to check valve cartridges

→ Do not disassemble check valve cartridges. Reassembly requires strict cleanroom conditions and great expertise. Sub-assemblies are not available for check valve cartridges.

-
- 1 Remove the inlet and outlet check valves; they are threaded into the liquid head.
 - 2 Remove the check valve cartridge. If needed, use compressed air to remove the cartridge. Do not use a sharp tool that could damage the check valve or the support.

- 3 Insert the new check valve cartridge into the support.

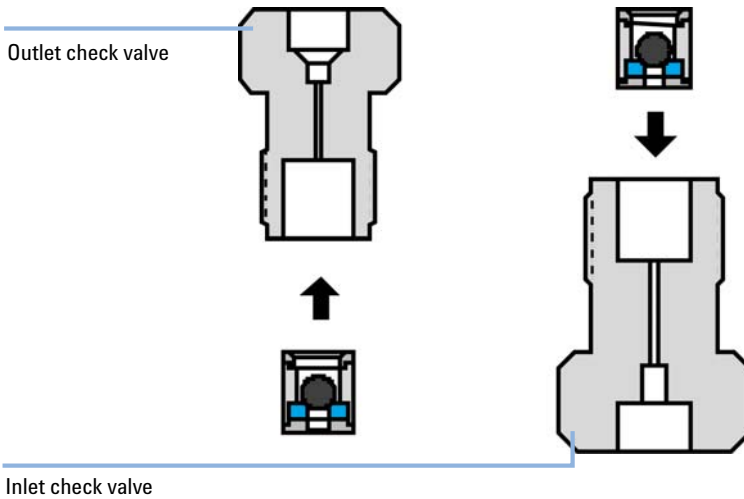

Figure 23 Orientation of check valve cartridges

NOTE

The outlet check valve housing is smaller than the inlet check valve housing, and threads into the top of the liquid head. The cartridge must be inserted in the check valve housing as shown below. The check ball must be above the seat in both types of check valve housing so that it will seat by gravity.

- 4 Tighten the check valves into the liquid head by hand, then tighten each liquid head a further 1/8th turn with an appropriately-sized open-ended wrench.

CAUTION

Damage to the liquid head and the check valve

→ Do not overtighten the check valve into the liquid head.

- 5 Run the pump and inspect for leaks around each check valve. If leaks are present, tighten the check valve only enough to stop the leak. Check for leaks again, tightening only if necessary.

Checking and Replacing the Mixer Outlet Filter Frit (Analytical and Narrowbore Mixers Only)

The analytical and narrowbore mixers incorporate a 2 μm frit pressed into the seal retainer to protect the downstream components of the HPLC system from particulate contamination. With normal use, this frit may become clogged, resulting in restricted flow through the mixer and HPLC system.

To check for restricted flow you will need a pressure module in the HPLC system between the pumps and the mixer.

Check the flow

- 1 Open the prime-purge valve so the flow is diverted to waste.
- 2 Run the pumps with methanol (rinsing first with water, if necessary) at a moderate flow rate (1 mL/min) and check the pressure monitor.

If the frit and the fluid lines are in good condition, the pressure reading on the monitor should be minimal. A reading over 100 psi (6.7 bar, 0.67 MPa) indicates that the frit is probably clogged and needs to be replaced. (A clogged frit cannot be cleaned.)

Replace the frit

The frit can be replaced without fully dismantling the mixer or disconnecting the outlet tubing.

- 1 Turn off the Agilent 218 Purification Solution.
- 2 Unscrew the mixer mounting panel from the Agilent 218 Purification Solution and disconnect the power connection.
- 3 Unthread the mixer cap by turning it counterclockwise. The outlet tubing fitting will still be connected.
- 4 Loosen and remove the seal retainer (includes frit).
- 5 Thread the replacement seal retainer and frit onto the piston. Finger-tighten the seal retainer.
- 6 Press the piston in the mixer body bore.
- 7 Replace the mixer cap.

Replacing the Mixer Seal

When If leaks are seen at the top of the mixer, and the correct outlet fitting is swaged properly, the seal may need to be replaced.

Replace the seal

The seal can be replaced without fully dismantling the mixer or disconnecting the outlet tubing.

- 1 Turn off the Agilent 218 Purification Solution.
- 2 Unscrew the mixer mounting panel from the Agilent 218 Purification Solution and disconnect the power connection.
- 3 Unthread the mixer cap by turning it counterclockwise. The outlet tubing fitting will still be connected.
- 4 Analytical and narrowbore mixers: Loosen and remove the seal retainer and frit. Remove the seal by pulling it away from the piston. Place a replacement seal on the piston so the spring inside the seal is visible. If the seal is put in upside down the seal will leak. Push the seal over the screw threads onto the shoulder. Thread the seal retainer onto the piston and finger-tighten. Do not use tools.

OR

Preparative mixers: Remove the seal by pulling it away from the piston. Slide the seal over the piston so the side of the seal with the larger outside diameter is closer to the bottom of the piston.

- 5 Press the piston, with seal (and seal retainer on analytical and narrowbore models), all the way into the mixer body bore.
- 6 Replace the mixer cap.

Checking and/or Changing Power Fuses (F1)

When If the Agilent 218 Purification Solution does not operate when the power cord is connected and the power switch is on, the fuse(s) may need replacing. Fuses are located in the power module on the back panel.

Tools required **Description**
Flat hat screwdriver

Parts required	#	Description
	1	T5 AH 250 V (115 V option)
OR	1	T3.15 AH 250 V (220 /230 V option)

Preparations Check following probable causes for the power fail before starting exchanging the fuses:

- Power cord properly connected
- Power at the wall receptacle

WARNING

Electrical shock

→ Always disconnect power cord from the module before replacing a fuse.

CAUTION

Wrong fuse

Damage to the module and loss of warranty.

→ Set voltage properly.

→ Use only the correct fuses.

Checking and/or Changing Power Fuses (F1)

1 Disconnect the module from the mains power supply.

2 Locate the fuse box on the right side of the back panel.



Fuse box

3 Inspect the fuse box to see what configuration your pump is set to. Look for the white plastic pip protruding through the hole next to the voltage setting.



Voltage set at 240 V

4 Gently pry open the fuse box door. To do this, use a small flat head screwdriver to carefully pry open the top and bottom left side and then the top and bottom right side. Open the fuse box door by pulling the right side away from the pump and swinging the door to the left.

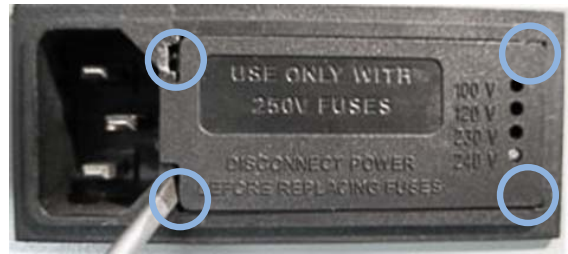

7 Maintenance and Repair

Checking and/or Changing Power Fuses (F1)

- 5 Lift the fuse holder out. Remove the two fuses for the 240 V setup and replace them or the single 120 V fuse.



Figure 24 120 V fuse in holder

NOTE

The fuse holder has a small cutout on the side (as shown in the previous figures) that fits around a small guide post located in the left side of the fuse box.

- 6 Slide the fuse holder back into the fuse box ensuring that the fuse is facing into the instrument. Once inserted, the fuse should not be visible. For details see instruction sheet (p/n 8510249500)



Switching the Mains Voltage

Preparations Power fuses are already checked and/or changed.

1 Disconnect the module from the mains power supply.

2 Locate the fuse box on the right side of the back panel.

Fuse box



7 Maintenance and Repair

Switching the Mains Voltage

- 3 Remove the voltage circuit card carefully with a needle nosed pliers.



- 4 To change the voltage selection, slide the plastic indicator around the holes on the circuit card.

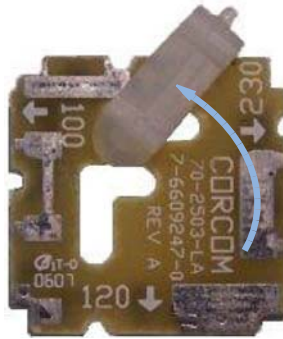

The tip of the plastic indicator points in the opposite direction of the required voltage and is locked in a small indent.

Plastic indicator lock

240 V position

120 V position

Plastic indicator lock

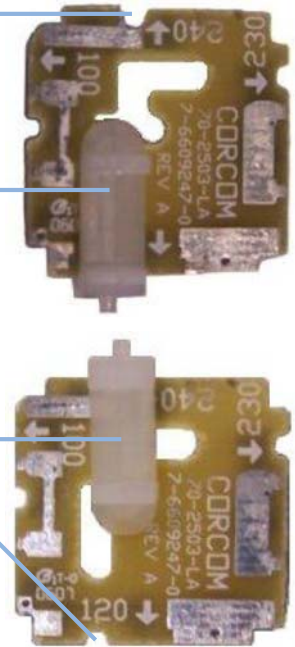

5 Slide the voltage circuit card back into the fuse box so that the tip on the plastic indicator faces out and the pointed side faces to the left.

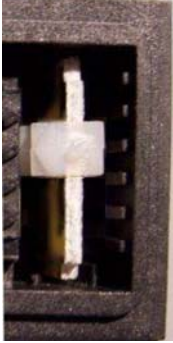

6 Change the indicator on the cover to the present voltage.

Voltage set at 120 V



7 To close the fuse box gently, push down the cover until the small tabs snap into place.

Tab on the fuse box cover

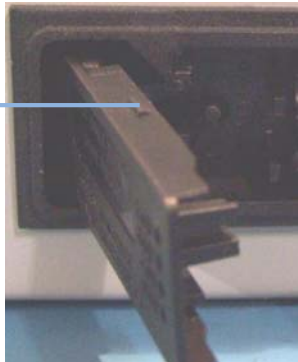

7 Maintenance and Repair

Switching the Mains Voltage



8 Parts

Parts List	108
Liquid Heads	109
Pressure Modules	110
Mixer	111
Standard Accessory Package	112

This chapter provides information on parts for the instrument.



Parts List

p/n	Description
G9300A	Agilent 218 Isocratic Solvent Delivery Module
G9301A	Agilent 218 Add-on Solvent Delivery Module

Liquid Heads

p/n	Description
R007101061	Standard head, max. flow: 10 mL/min, material: SST
R007101062	Washing head, max. flow: 10 mL/min, material: SST
R007101063	Washing head, max. flow: 10 mL/min, material: Titanium
R007101064	Standard head, max. flow: 25 mL/min, material: SST
R007101073	Washing head, max. flow: 10 mL/min, material: PEEK
R007101074	Washing head, max. flow: 25 mL/min, material: PEEK
R007101076	Washing head, max. flow: 100 mL/min, material: PEEK
R007101077	Washing head, max. flow: 100 mL/min, material: Titanium
393650701	Washing head, max. flow: 200 mL/min, material: Titanium

Pressure Modules

p/n	Description
393552501	Pressure module, flow: 10 mL/min, max. pressure rating: 599.84 bar (8700 psi), wetted material: Titanium, FEP
393552601	Pressure module, flow: 50 mL/min, max. pressure rating: 413.69 bar (6000 psi), wetted material: Titanium, FEP
393552701	Pressure module, flow: 100 mL/min, max. pressure rating: 82.74 bar (1200 psi), wetted material: Titanium, FEP
393552801	Pressure module, flow: 10 mL/min, max. pressure rating: 275.79 bar (4000 psi), wetted material: PEEK, FEP
393552901	Pressure module, flow: 50 mL/min, max. pressure rating: 275.79 bar (4000 psi), wetted material: PEEK, FEP
393553001	Pressure module, flow: 100 mL/min, max. pressure rating: 137.9 bar (2000 psi), wetted material: PEEK, FEP
393650501	Pressure module, flow: 200 mL/min, max. pressure rating: 275.79 bar (4000 psi), wetted material: Titanium, FEP

Mixer

p/n	Description
393554601	Mixer, volume: 0.6 mL, material: SST, wetted materials: 316 Stainless Steel, PTFE, Hastelloy, Fluoroly 12, type: Narrowbore
393554701	Mixer, volume: 0.6 mL, material: Titanium, wetted materials: Titanium, PTFE, Fluorowhite, type: Narrowbore
393554801	Dual chamber mixer, volume: 1.2 mL, material: SST, wetted materials: 316 Stainless Steel, PTFE, Hastelloy, Fluoroly 12, type: Analytical
393555001	Dual chamber mixer, volume: 1.2 mL, material: PEEK, wetted materials: Titanium, PTFE, PEEK, UHMWPE, Fluorowhite, type: Analytical
393554901	Dual chamber mixer, volume: 1.2 mL, material: Titanium, wetted materials: Titanium, PTFE, Fluorowhite, type: Analytical
393555201	Dual chamber mixer, volume: 10 mL, material: PEEK, wetted materials: PEEK, PTFE, Perfluoro, Fluorowhite, type: Preparative
393555101	Dual chamber mixer, volume: 10 mL, material: Titanium, wetted materials: Titanium, PTFE, Perfluoro, Fluorowhite, type: Preparative

Standard Accessory Package

p/n	Description
393550991	Standard accessory kit

The standard accessory kit contains the following parts:

p/n	Description
5140892700 (2x)	External Contacts Panel, 12 pin
R005400012	Double-ended wrench, 1/4 in. and 5/16 in.
R007200141	Cable, Recorder/Integrator
6713543000 (2x)	Fuse, 3 A
5550033300 (2x)	Fuse, 1.6 A
5910007600	Cable 3 wire main C/W plug /SKT
8510249500	Voltage conversion instructions



9 Cables

Cable Overview 114

Cable Connections 115

This chapter provides information on cables used with the instrument.



Cable Overview

Necessary cables

p/n	Description
392612901	Ethernet cable (for use in a <i>network</i>)
OR 5023-0203	Ethernet cable (cross-over, for <i>standalone</i> use)
392607969	Inject marker cable
392607975	Next injection cable
393546291	Serial communication ribbon
393597601	Converter RS-232 to RS-422
7910046300	Serial cable

Optional cables

p/n	Description
110743800	Relay interface cable (for relay interface board, one relay contact per cable)
110744200	Analog signal cable

Cable Connections

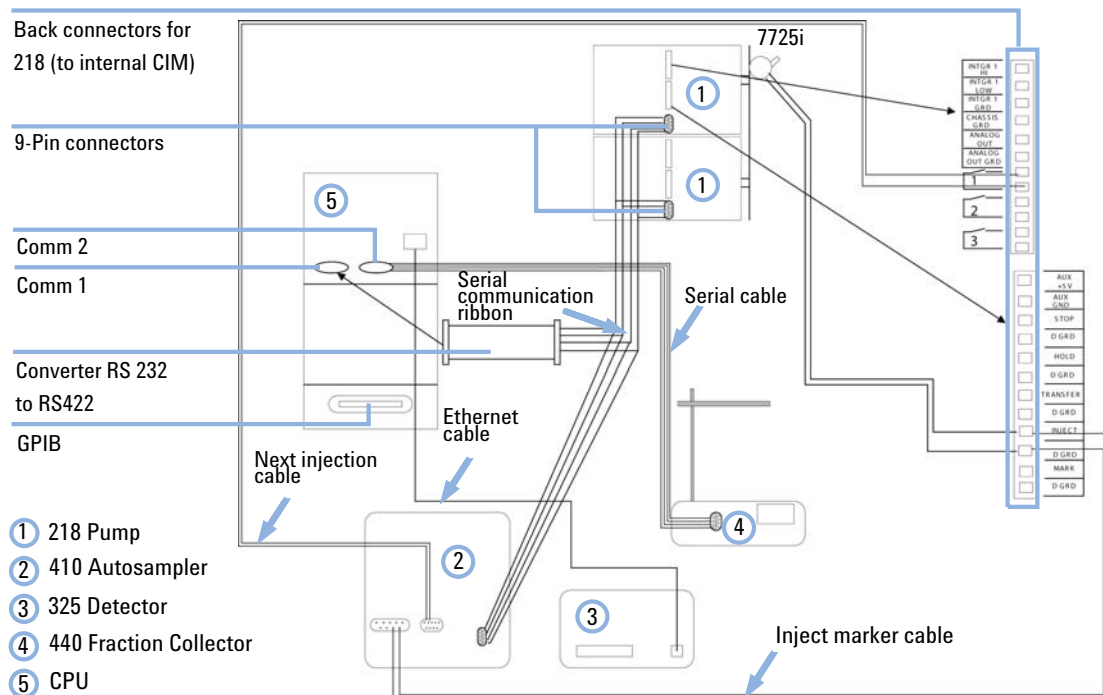

Figure 25 Cable connections for workstation control of Agilent 218 Pumps, Agilent 325 Detector, Agilent 410 Autosampler and Agilent 440 Fraction Collector

9 Cables
Cable Connections



10 Appendix

General Safety Information	118
Solvent Miscibility	124
Solvent Compressibility	125
The Waste Electrical and Electronic Equipment Directive	127
Batteries Information	128
Radio Interference	129
Electromagnetic Compatibility	130
Agilent Technologies on Internet	132

This chapter provides addition information on safety, legal and web.



General Safety Information

General Safety Information

The following general safety precautions must be observed during all phases of operation, service, and repair of this instrument. Failure to comply with these precautions or with specific warnings elsewhere in this manual violates safety standards of design, manufacture, and intended use of the instrument. Agilent Technologies assumes no liability for the customer's failure to comply with these requirements.

WARNING

Ensure the proper usage of the equipment.

The protection provided by the equipment may be impaired.











→ The operator of this instrument is advised to use the equipment in a manner as specified in this manual.

Information Symbols

The following is a list of symbols that appear with warnings in this manual or on the liquid chromatograph. The hazard they describe is also shown.

A triangular symbol indicates a warning. The meanings of the symbols that may appear alongside warnings in the documentation or on the instrument itself are as follows:

Table 27 Warning symbols





		
Broken glass	Chemical hazard	Electrical shock
		
Explosion hazard	Eye hazard	Fire hazard
		
Heavy weight (danger to feet)	Heavy weight (danger to hands)	Hot surface
		
Moving parts	Respiratory hazard	Attention ¹

¹ The symbol may be used on warning labels attached to the instrument. When you see this symbol, refer to the relevant operation or service manual for the correct procedure referred to by that warning label.

10 Appendix

General Safety Information

Table 28 Information symbols

Symbol	Description
I	Mains power on
o	Mains power off
	Fuse
	Single phase alternating current
	Direct current
	Confirms that the product complies with the requirements of all applicable European Community directives

Solvent Hazards

WARNING

Explosion, fire, asphyxiation

This instrument is not explosion-proof.

Certain solvents may cause weakening and leaks of tubings or fittings with possible bursting.

Even small leaks in solvent supply systems can be dangerous.

- Only use solvents compatible with the HPLC system tubings and fittings.
 - Employ static measuring and static discharge devices to safeguard against the buildup of static electricity.
 - In unattended operation, do not use organic solvents having an ignition point below 70 °C.
 - Do not bring a heat or flame source near the instrument.
 - The area in which solvents are stored and the area surrounding the instrument must be adequately ventilated to prevent accumulations of gas.
 - Always check the condition of the instrument (leakage of solvent or waste solution, leakage of solvent inside the instrument). If an abnormality is found, stop operation immediately.
 - When using flammable chemicals, be careful about possible ignition due to static electricity. To prevent the build-up of static electricity, use a conductive container for waste.
 - Use only approved regulator and hose connectors (refer to the supplier's instructions).
 - Keep solvents cool and properly labeled. Ensure that you have the correct solvent before connecting it to the instrument.
-

WARNING

Inflammation or injury due to toxic, corrosive or stimulative solvent

- Do not contact toxic, corrosive or stimulative solvent.
 - For details of the properties of each solvent and how to handle it, refer to the relevant Material Safety Data Sheets (MSDS).
 - Be sure to handle each solvent properly.
 - Wear proper personal protective clothes (e.g., safety goggles) so that a solvent will not come into direct contact with the skin.
 - Ventilate the laboratory room adequately to prevent accidental inhalation of harmful solvent vapor.
-

WARNING

Cuts

- When working with glass or quartz parts take care to prevent breakage.
-

Other Precautions

Airflow to the cooling fans of the liquid chromatograph must be unobstructed. Do not block the ventilation grills on the liquid chromatograph and accessories.

Consult the manuals supplied with your PC, monitor and for their specific ventilation requirements.

High Pressure Hazards

WARNING

High velocity stream of volatile and/or toxic liquids.

If a line ruptures, a relief device opens, or a valve opens accidentally under pressure, potentially hazardous high liquid pressures can be generated by the pump.

- Wear personal protective equipment when you inject samples or perform routine maintenance.
 - Never open a solvent line or valve under pressure. Stop the pump first and let the pressure drop to zero.
 - Always keep the doors and covers closed during operation.
 - Read and adhere to all Notes, Cautions, and Warnings in the manual.
-

Solvent Miscibility

Solvents should mix with each other in all proportions. This is important during elution and during solvent changeover. Refer to [Figure 26](#) on page 124 for miscibility of some common HPLC solvents.

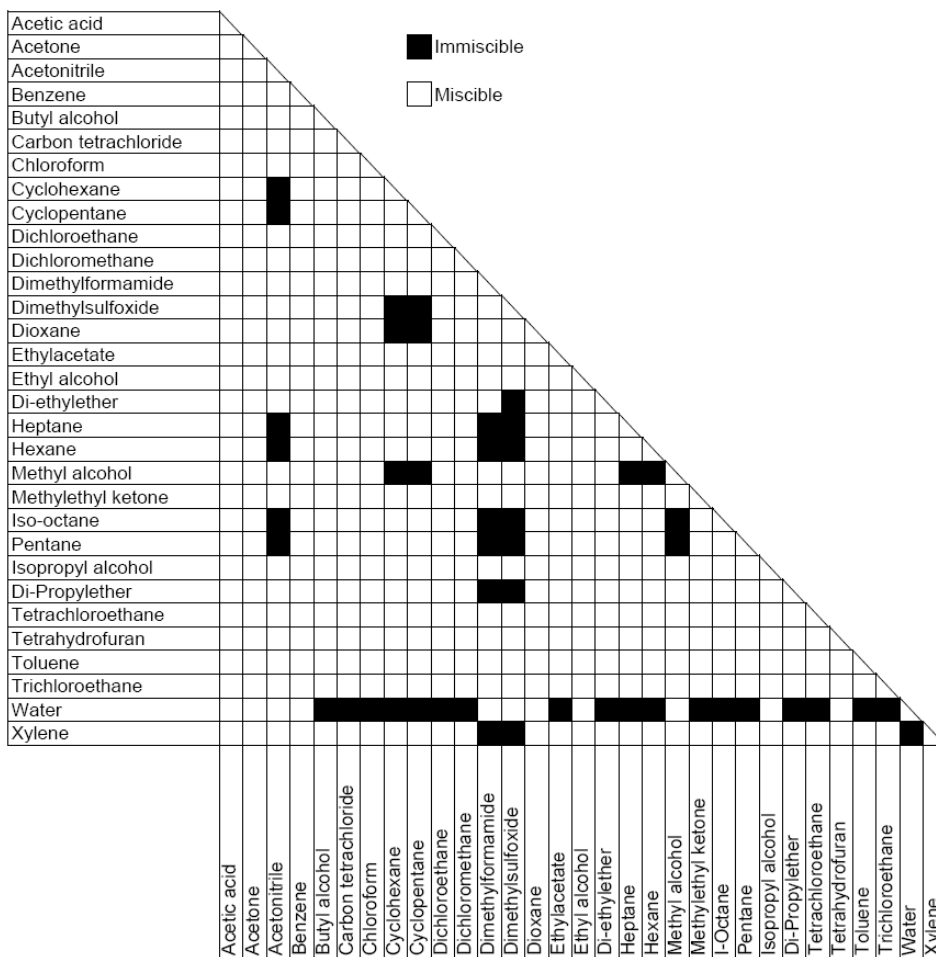

Figure 26 Solvent miscibility of some common solvents

Solvent Compressibility

The values in [Table 29](#) on page 125 should be used for the Agilent 218 Purification Solution compressibility factors when you are setting up the pumping system parameters.

For details on how to set up the pump system parameters, refer to [“Adjusting the Flow Rate on the Pump”](#) on page 81.

Table 29 Compressibility factors

Solvent	x	L
Water	46	3231
Acetone	128.9	956
Acetonitrile	97.4	1212
Benzene	96.7	1046
Carbon tetrachloride	106.7	998
Chloroform	97.4	1227
Cyclohexane	114	800
Dichloroethane	111.9	1020
Diethyl ether	188	700
Dimethylformamide	80	1500
Dioxane	60	1500
Ethanol	115	1100
Ethyl acetate	100	1800
Methylene chloride	97.4	1212
Methanol	125	1200
n Heptane	144	760
n Hexane	167.2	644
o Dichlorobenzene	95	1400

10 Appendix

Solvent Compressibility

Table 29 Compressibility factors

Solvent	x	L
Propanol	98	1200
Tetrahydrofuran	95	1500
Toluene	93	1200
2-Methylformamide	80	1500

The Waste Electrical and Electronic Equipment Directive

Abstract

The Waste Electrical and Electronic Equipment (WEEE) Directive (2002/96/EC), adopted by EU Commission on 13 February 2003, is introducing producer responsibility on all electric and electronic appliances starting with 13 August 2005.

NOTE

This product complies with the WEEE Directive (2002/96/EC) marking requirements. The affixed label indicates that you must not discard this electrical/electronic product in domestic household waste.

Product Category:

With reference to the equipment types in the WEEE Directive Annex I, this product is classed as a Monitoring and Control Instrumentation product.



NOTE

Do not dispose off in domestic household waste

To return unwanted products, contact your local Agilent office, or see www.agilent.com for more information.

Batteries Information

WARNING

Lithium batteries may not be disposed-off into the domestic waste. Transportation of discharged Lithium batteries through carriers regulated by IATA/ICAO, ADR, RID, IMDG is not allowed.

Danger of explosion if battery is incorrectly replaced.

- Discharged Lithium batteries shall be disposed off locally according to national waste disposal regulations for batteries.
 - Replace only with the same or equivalent type recommended by the equipment manufacturer.
-



WARNING

Lithiumbatteri - Eksplosionsfare ved fejlagtig håndtering.

Udskiftning må kun ske med batteri af samme fabrikat og type.

- Lever det brugte batteri tilbage til leverandøren.
-

WARNING

Lithiumbatteri - Eksplosionsfare.

Ved udskiftning benyttes kun batteri som anbefalt av apparatfabrikanten.

- Brukt batteri returneres apparatleverandøren.
-

NOTE

Bij dit apparaat zijn batterijen geleverd. Wanneer deze leeg zijn, moet u ze niet weggooien maar inleveren als KCA.

Radio Interference

Cables supplied by Agilent Technologies are screened to provide optimized protection against radio interference. All cables are in compliance with safety or EMC regulations.

Test and Measurement

If test and measurement equipment is operated with unscreened cables, or used for measurements on open set-ups, the user has to assure that under operating conditions the radio interference limits are still met within the premises.

Electromagnetic Compatibility

EN55011/CISPR11

Group 1 ISM equipment: group 1 contains all ISM equipment in which there is intentionally generated and/or used conductively coupled radio- frequency energy which is necessary for the internal functioning of the equipment itself.

Class A equipment is equipment suitable for use in all establishments other than domestic and those directly connected to a low voltage power supply network which supplies buildings used for domestic purposes.

This device complies with the requirements of CISPR11, Group 1, Class A as radiation professional equipment. Therefore, there may be potential difficulties in ensuring electromagnetic compatibility in other environments, due to conducted as well as radiated disturbances.

Operation is subject to the following two conditions:

- This device may not cause harmful interference.
- This device must accept any interference received, including interference that may cause undesired operation.

If this equipment does cause harmful interference to radio or television reception, which can be determined by turning the equipment off and on, the user is encouraged to try one or more of the following measures:

- Relocate the radio or antenna.
- Move the device away from the radio or television.
- Plug the device into a different electrical outlet, so that the device and the radio or television are on separate electrical circuits.
- Make sure that all peripheral devices are also certified.
- Make sure that appropriate cables are used to connect the device to peripheral equipment.
- Consult your equipment dealer, Agilent Technologies, or an experienced technician for assistance.
- Changes or modifications not expressly approved by Agilent Technologies could void the user's authority to operate the equipment.

ICES/NMB-001

This ISM device complies with Canadian ICES- 001.

Cet appareil ISM est conforme à la norme NMB-001 du Canada.

Agilent Technologies on Internet

For the latest information on products and services visit our worldwide web site on the Internet at:

<http://www.agilent.com>

Index

2

200 mL/min head
seal removal 87

A

accessory package 112
Agilent
on internet 132
air bubbles
clearing 82

B

battery
safety information 128
bench space 34

C

check valve
overview 18
check valves
cleaning 94
replacing 96
condensation 34
connections
workstation control 115

D

dimension 35
dual chamber 20

E

electronic waste 127

F

flow rate
adjusting 81

H

high pressure mixer 20
high pressure
hazard 123

I

internet 132
introduction
system 10

L

layout 12
liquid heads 109
lithium batteries 128

M

method menu 48
method
check 46
creating 45
run 46
mixer seal
replacement 99
mixer 111

P

parts
list 108
piston seal

replacement 200 mL/min head 90
replacement 88
power cords 33
power fuses
change 100
check 100
power on 43
pressure display
functions 65
pressure limits
pump head 37
pressure module
overview 14
pressure modules 110
pump head
priming 44

R

radio interference 129
replacement
mixer seal 99

S

safety information
lithium batteries 128
safety
general information 118
sample methods 54
schedule
maintenance 77
seal
200 mL/min 87
service logs 79
site requirements

Index

- power cords 33
- solution
 - air bubble in tubing 69
 - baseline spikes 72
 - erratic pressure 69
 - excessive backpressure 69
 - excessive pressure 68
 - flat top peaks 71
 - leaks 67
 - low flow 68
 - no flow 67
 - no pressure 67
 - noisy baseline 71, 70
 - restricted flow 68
- specifications
 - performance 36
 - physical 35
- standard head
 - seal removal 83

T

- temperature
 - range 35
- troubleshooting
 - guide 66
 - introduction 64

V

- voltage 35

W

- washing head
 - seal removal 85
- waste
 - electrical and electronic equipment 127
- WEEE directive 127
- weight 35

www.agilent.com

In This Book

The manual describes the following:

- Introduction
- Site requirements
- Installation
- Using
- Troubleshooting and error information
- Maintenance and repair
- Parts
- Safety

© Agilent Technologies 2012, 2013

Printed in Germany
01/2013



G9300-90001



Agilent Technologies