

ITM. / ART. 3232432

Gourmia®



Digital Air Fryer

GAF685

USER MANUAL

IMPORTANT, RETAIN FOR FUTURE REFERENCE: READ CAREFULLY

FOR CUSTOMER SERVICE
QUESTIONS OR COMMENTS
VISIT US @ GOURMIA.COM
INFO@GOURMIA.COM
OR CALL 888.552.0033
MON-THU 9:00AM TO 6:00PM ET
AND FRI 9:00AM TO 3:00PM ET
LANGUAGES SUPPORTED: ENGLISH, SPANISH

Model: GAF685
© 2019 Gourmia
www.gourmia.com
The Steelstone Group
Brooklyn, NY

All rights reserved. No portion of this manual may be reproduced by any means whatsoever without written permission from The Steelstone Group, except for the inclusion of quotations in a media review.

Although every precaution has been taken in the preparation of this manual, The Steelstone Group assumes no responsibility for errors or omissions. Nor is any liability assumed for damages resulting from the use of the information contained herein. Although every effort has been made to ensure that the information contained in this manual is complete and accurate, The Steelstone Group is not engaged in rendering professional advice or services to the individual consumer; further, The Steelstone Group shall not be held responsible for any loss or damage allegedly arising from any information or suggestion in this manual.



Welcome to the Exciting World of *Air Frying* from Gourmia

Here at Gourmia, we're all about helping cooks make easy, healthy, and delicious meals an everyday possibility. We know how fast-paced life is and that sometimes a home cooked meal doesn't make the top of the priority list, no matter how bad you want it. Our dependable, easy-to-use products are here to help you change that. We're giving you the tools to eat better and healthier without spending hours in the kitchen prepping and cooking.

We want you to get the most out of your product, which is why our team is available to help with any questions you may have. Whether you have a question with setup or need some guidance on which preset to use, we're happy to walk you through it. Welcome to the ease of cooking with Gourmia.

This manual provides instructions for all of the product's functions and features along with directions for assembling, operating, cleaning, and maintaining the appliance. Please read all safety instructions and directions for safe usage at all times. Keep this manual for future use.

Thank you for choosing Gourmia!

We love hearing from you! Share your thoughts, recipes, and photos with us.

@gourmia



IMPORTANT SAFEGUARDS

Read all instructions before using the electric appliance. The following basic precautions should always be followed:

1. This appliance is not intended for use by persons (including children younger than 8) with reduced physical, sensory or mental capabilities, or lack of experience and knowledge, unless they have supervision.
2. Check if the voltage indicated on the appliance corresponds to the local main voltage before you connect the appliance.
3. Do not use the appliance if the plug, the main cord or the appliance itself is damaged. Always make sure that the plug is inserted properly into a wall outlet.
4. Do not operate any appliance with a damaged cord or plug, after the appliance malfunctions, or has been damaged in any manner. Return appliance to the nearest authorized service facility for examination, repair, or adjustment.
5. Close supervision is necessary when any appliance is used near children. Children should be supervised to ensure that they do not play with the appliance. Cleaning and user maintenance shall not be done by children unless they are older than 8 and supervised.
6. Do not let the cord hang over the edge of the table or counter or touch hot surfaces.
7. To protect against electric shock, do not immerse cord, plugs, or appliance in water or other liquid. Do not plug in the appliance or operate the control panel with wet hands.
8. Never connect this appliance to an external timer switch or separate remote-control system in order to avoid a hazardous situation. To disconnect, turn off the appliance, then remove plug from wall outlet.
9. This appliance has a polarized plug (one blade is wider than the other). To reduce the risk of electric shock, this plug is intended to fit into a polarized outlet only one way. If the plug does not fit fully into the outlet, reverse the plug. If it still does not fit, contact a qualified electrician. Do not attempt to modify the plug in any way.
10. Do not place the appliance on or near combustible materials such as a tablecloth or curtain. The accessible surfaces may become hot during use. Do not place on or near a hot gas or electric burner, or in a heated oven.
11. Do not place the appliance against a wall or against other appliances. Leave at least 4 inches of free space on the back and sides and 4 inches of free space above the appliance. Do not place anything on top of the appliance.
12. Do not use the appliance for any other purpose than described in this manual. The use of accessory attachments not recommended by the appliance manufacturer may cause injuries.
13. Do not let the appliance operate unattended. Extreme caution must be used when moving an appliance containing hot oil or other hot liquids.
14. Do not use outdoors.
15. Do not touch the hot surfaces; use handle. During air frying, hot steam is released through the air outlet openings. Keep your hands and face at a safe distance from the steam and from the air outlet openings. Also be careful of hot steam and air when you remove the pan from the appliance.
16. After using the appliance, avoid contact with the hot metal inside. Unplug from outlet when not in use and before cleaning. Allow to cool before cleaning the appliance.
17. Immediately unplug the appliance if you see dark smoke coming out of the appliance. Wait for the smoke emission to stop before you remove the pan from the appliance.
18. For household use only.

SAVE THESE INSTRUCTIONS

TABLE OF CONTENTS

Know Your Air Fryer.....6

Using Your Air Fryer8

Troubleshooting.....11

Air Frying Tips 12

Settings Chart..... 13

Cleaning & Maintenance.....14



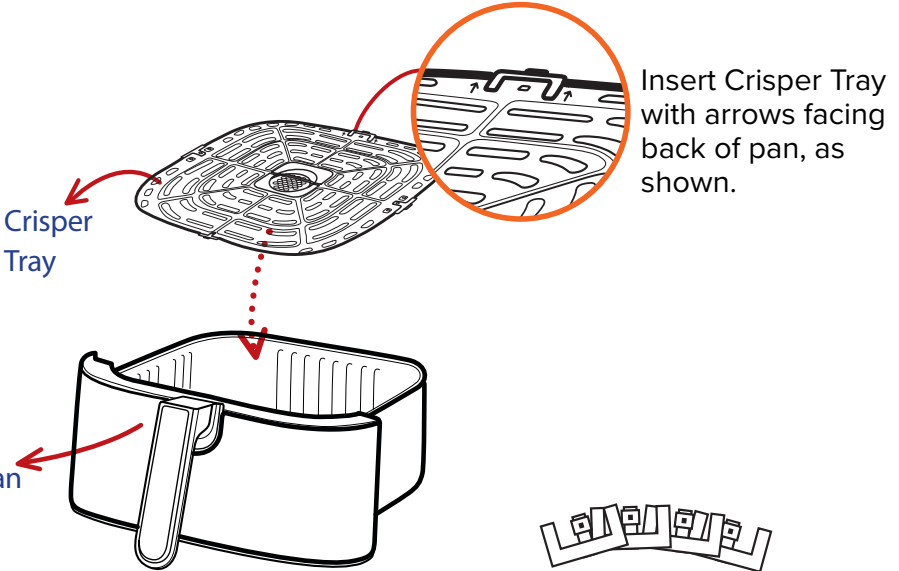
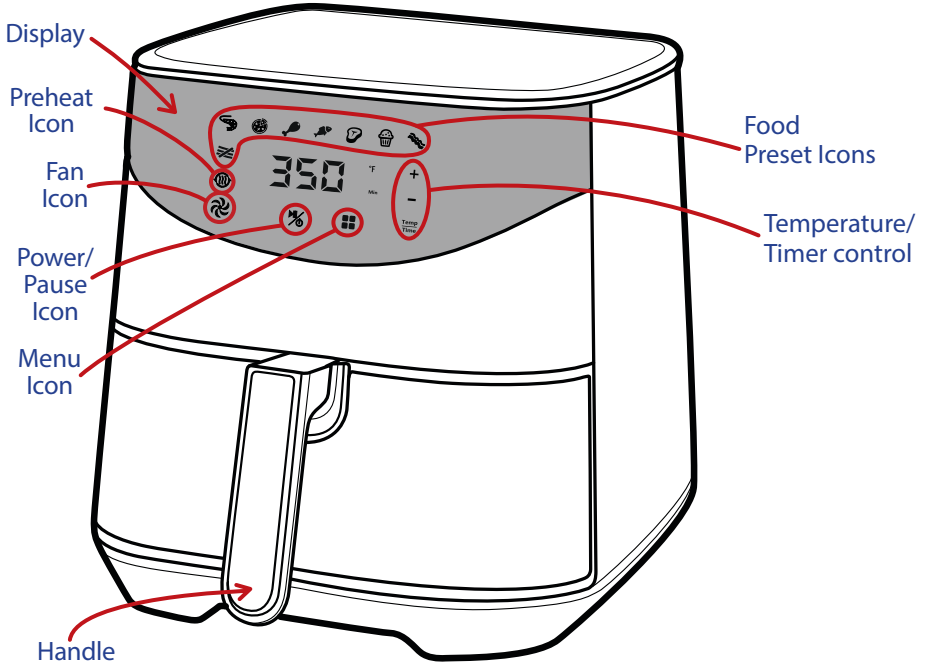

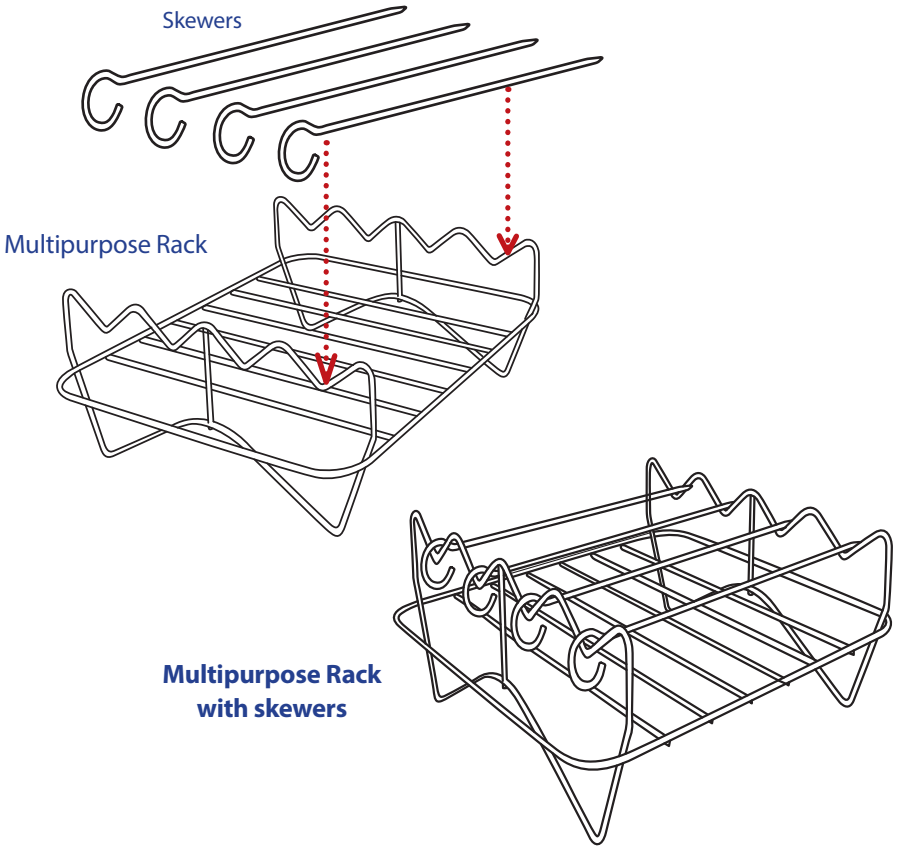

Extra Rubber Bumpers

NOTE: For your convenience, this air fryer comes with an extra crisper tray and extra rubber bumpers. Only use one crisper tray while air frying.



Note: You can use the multipurpose rack for additional cooking space, as a raised cooking surface, or cooking with skewers.

ICON LEGEND

 FRENCH FRIES	 FISH
 SHELLFISH	 STEAK
 PIZZA	 CAKE
 POULTRY	 BACON

Before Using The Air Fryer For The First Time

1. Remove all packaging stickers, or labels from the appliance including the tape securing the pan to the unit.
2. To pull out the pan for cleaning, remove the tape securing it into place. Secure the unit with one hand and pull the handle straight back with the other hand.
3. Thoroughly clean the pan and accessories with hot water, some dishwashing liquid, and a non-abrasive sponge.
4. Wipe the inside and outside of the appliance with a moist cloth.



Note: During the first few uses, there might be a “hot plastic” smell. This is perfectly normal in new Air Fryers as the material is heated for the first time. It will go away after the first few uses.

Using Your Air Fryer

This is an air fryer that works using hot air.

- Do not fill the pan with oil, frying fat, or any other liquid.
- Do not put anything on top of the appliance.

Note: Do not place the appliance against a wall or against other appliances. It is important to leave at least 4 inches of free space on the back and sides, and 4 inches of free space above the appliance to allow for proper ventilation.

1. Place the appliance on a stable, horizontal, heat-resistant, and level surface.
2. Plug the Air Fryer into a wall outlet.
3. Tap the power icon, to turn on the appliance.
4. Preheat the air fryer by tapping the menu icon until the preheat icon appears. Tap the power icon to begin preheating. When preheating is done, the Air Fryer will beep 5 times.

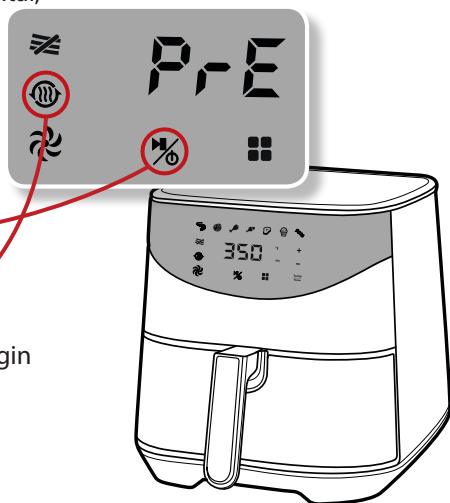

5. Slide the pan out of the Air Fryer.

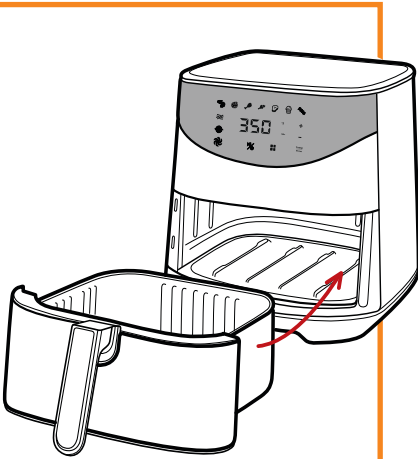

6. Place the ingredients in the pan - do not overload. Spray with cooking oil for a crispier finish. Slide the pan into the air fryer.



7. To select a preset, tap the menu icon until desired food icon appears. The temperature and time will appear on the screen.

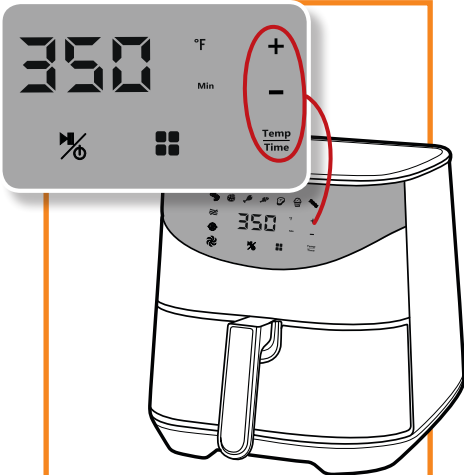

8. To set the temperature and time manually, or to adjust the preset temperature or time, tap the +/- icons. Tap Temp/Time to alternate between setting temperature and time.

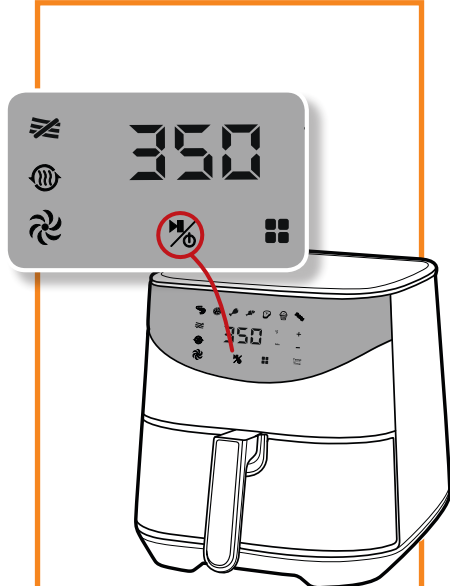

9. To begin the air frying process, tap the power icon.

10. Some recipes or ingredients call for shaking the ingredients halfway through the preparation time (see 'Settings Chart' on page 13). To shake the ingredients, pull the pan out of the appliance by the handle and shake it. Slide the pan back into the air fryer to resume cooking.

NOTE: After sliding the pan out of the appliance, the display unit will go into sleep mode. When you return the pan to the appliance, your time and temperature settings will automatically resume. There is no need to reset your settings or press start.

11. When your selected cook time has elapsed, the timer bell will ring. Pull the pan out of the appliance and place it on a heat-resistant surface. If you would like a little more cooking time on the food, simply slide the pan back into the appliance and set the timer for a few extra minutes.

12. When your food is ready, empty the pan into a bowl or onto a plate using a pair of tongs; the food and pan will be hot!

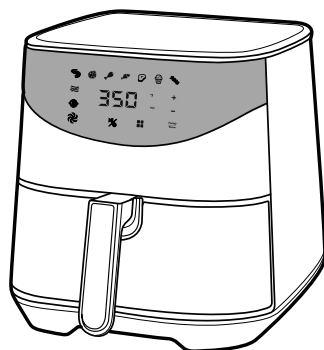

NOTES:

- **Do not turn the pan upside down, as any excess oil that has collected on the bottom of the pan will leak onto the food.**
- **To avoid scratching the nonstick surface, do not use sharp or metal utensils.**
- **When a batch of ingredients is ready, the air fryer is instantly ready for preparing another batch. No preheating is necessary.**
- **To pause the air fryer, tap the power/pause icon. Tap it again to resume.**
- **To turn off the air fryer, press and hold the power icon. The air fryer may cool down for 20 seconds before shutting off.**

Caution: After hot air frying, the pan and the ingredients are hot - avoid touching. Depending on the type of the ingredients in the air fryer, steam may escape from the pan.

PROBLEM	POSSIBLE CAUSE	SOLUTION
The air fryer does not work.	The appliance is not plugged in.	Plug the main plug into a grounded wall socket.
	You have not set the timer.	Tap the timer icon to set the required cook time to turn on the appliance.
	The pan is not put into the appliance properly.	Slide the pan into the appliance properly.
The ingredients fried in the air fryer are not done.	The amount of ingredients in the pan are too much.	Put smaller batches of ingredients in the pan. Smaller batches are fried more evenly.
	The set temperature is too low.	Tap the temperature icon to set the required temperature setting. (See 'Settings Chart' on page 13)
	The cook time is too short.	Tap the timer icon to set the required cook time. (See 'Settings Chart' on page 13)
The ingredients are fried unevenly in the air fryer.	Certain types of ingredients need to be shaken halfway through the cook time.	Ingredients that lie on top of or across each other (e.g.fries) need to be shaken halfway through the preparation time. (See 'Settings Chart' on page 13)
Fried snacks are not crispy when they come out of the air fryer.	You used a type of snack meant to be cooked in a traditional deep fryer.	Use oven snacks or lightly brush some oil onto the snacks for a crispier result.
I cannot slide the pan into the appliance properly.	The pan is overfilled.	Do not fill the pan beyond max line (see 'Settings Chart' on page 13).
White smoke comes out of the appliance.	You are preparing greasy ingredients.	When you fry greasy ingredients in the air fryer, a large amount of oil will leak into the pan. The oil produces white smoke and the pan may heat up more than usual. This does not affect the appliance or the end result.
	The pan still contains grease residue from previous use.	White smoke is caused by grease heating up in the pan. Make sure you clean the pan properly after each use.
Fresh fries are fried unevenly in the air fryer.	Quality potatoes will give an even cook.	Use fresh potatoes and make sure they stay firm during frying.
	Potatoes are too starchy.	Rinse the potato sticks properly and dry to remove starch from the outside of the sticks.
Fresh fries are not crispy when they come out of the air fryer.	The crispiness of the fries depends on the amount of oil and water in the fries.	Make sure you dry the potato sticks properly before you add the oil. Cut the potato sticks smaller for a crispier result. Add slightly more oil for a crispier result.

AIR FRYING TIPS

- Smaller ingredients usually require a slightly shorter cook time than larger ingredients.
- Shaking smaller ingredients halfway through the cook time optimizes the end result and can help prevent unevenly fried ingredients.
- Add 1 tablespoon of oil to fresh potatoes for a crispy result. Fry your ingredients in the air fryer within a few minutes after you add the oil.
- Do not prepare extremely greasy ingredients such as sausages in the air fryer.
- Snacks that can be prepared in an oven can also be prepared in the air fryer.
- Use pre-made dough to prepare filled snacks quickly and easily. Pre-made dough also requires a shorter preparation time than home-made dough.
- Place a baking tin or oven dish in the air fryer pan if you want to bake a cake or quiche, or if you want to fry fragile or filled ingredients.

Note: *Because the rapid hot air technology instantly reheats the air inside the appliance, pulling the pan out of the appliance during use, for a short amount of time, will not affect the process.*

Using the Timer

Option 1:

Timer can be set to ring when it's time to shake ingredients by setting the timer to half of the total cook time. However, you will have to set the timer again for the remaining cook time after pan is replaced into the air fryer. (See 'Settings Chart' on page 13.)

Option 2:

If the timer is set for the entire cook time, there will be no timer notifying you halfway through to shake ingredients. You can pull out the pan at anytime to check the food. The power will automatically shut off and will resume after the pan is replaced into the air fryer.

Warning:

Do not touch the pan, crisper, rack and skewers after use. Depending on the type of the ingredients in the air fryer, steam may escape from the pan.

SETTINGS CHART

The settings below are only suggestions. As ingredients differ in origin, size, shape, as well as brand, we cannot guarantee the best setting for your ingredients.

	Portion	Time (min)	Temperature	Shake/Flip	Extra information
POTATOES & VEGETABLES					
Thin frozen fries	8 oz	8-12	400	shake every 5 min.	
Thick frozen fries	8 oz	10-15	400	shake every 5 min.	
Frozen onion rings	8 oz	8-10	400	flip halfway	
Roasted zucchini	1 medium sliced	8-10	400	flip halfway	spray with oil
Roasted broccoli	8 oz	10-15	400	shake halfway	spray with oil
Fresh thin fries	8 oz	12-15	400	shake every 5 min.	spray with oil
Fresh thick fries	8 oz	15-20	400	shake every 5 min.	spray with oil
Fresh hash browns	4 pieces	10-12	375	flip halfway	
MEAT & FISH					
Frozen chicken fingers	8 oz	10-20	400	flip halfway	
Frozen fishsticks	8 oz	10-20	400	flip halfway	
Fresh fish fillet	2-4 fillets	10-12	400	flip halfway	
Steak (medium)	8 oz	10-15	400	flip halfway	
Chicken breast	2-4 Breast	20-25	375	flip halfway	
Chicken wings	6-8 Wings	10-15	400	flip halfway	
Chicken legs	4-6 Legs	20-25	375	flip halfway	
Chicken thighs	4-6 Thighs	20-25	375	flip halfway	
Hamburgers	4 oz. Patties	8-10	400	flip halfway	
BAKING					
Cake	8 inch round	25-30	325		
Cupcakes	6 cupcakes	15-20	325		

Air fryers perform similar to ovens. If your dish is not on the list, please refer to oven instructions on item packaging or recipe.

CLEANING AND MAINTENANCE

- Clean the appliance after every use.
- Make sure the appliance is completely cooled off before cleaning.
- Do not use metal kitchen utensils or abrasive cleaning material to clean the pan and crisper, as this may damage the non-stick coating.



1. Remove the main plug from the wall outlet and let the appliance cool down.

Note: Remove the pan from the air fryer to help the air fryer cool down quicker.

2. Wipe the outside of the appliance with a moist cloth.
3. Clean the pan, crisper, multipurpose rack, and skewers with hot water, some dishwashing soap, and a non-abrasive sponge.

Tip: If residue is stuck to the bottom of the pan, fill the pan with hot water and some dishwashing soap and let the pan soak for approximately 10 minutes.

4. Clean the inside of the air fryer with hot water and a cleaning brush to remove any food residue.

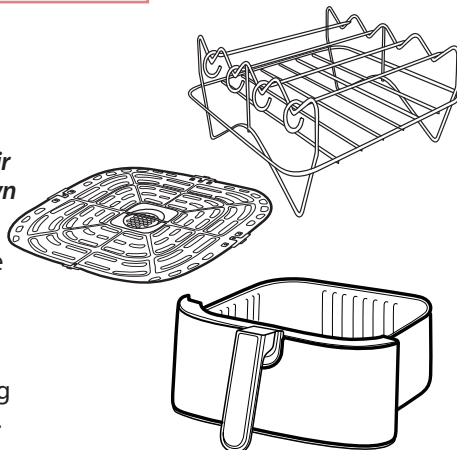

STORAGE

- Unplug the appliance and let it cool down.
- Make sure all parts are clean and dry.
- Store the air fryer in a clean and dry place.

Environment

Do not throw away the appliance with the normal household waste at the end of its life, but hand it in at an official collection point for recycling. By doing this, you help to preserve the environment.

Guarantee and service

If you need service or information or if you have a problem, please visit our website or contact your distributor.

WARRANTY & SERVICE

This Limited Warranty is for one full year from the date of purchase. It is applicable to the original purchaser only and is not transferable to a third party user. Repair or replacement of defective parts is solely at the seller's discretion. In the event that repair isn't possible, the seller will replace the product/part. If product repair/replacement won't suffice, the seller has the option of refunding the cash value of the product or component returned.

Product defects not covered under the Warranty provisions include normal wear and damage incurred from use or accidental negligence, misuse of instruction specifications or repair by unauthorized parties. The manufacturing company is not liable for any incidental or consequential damages incurred by such circumstances.

DISTRIBUTED BY:
COSTCO WHOLESALE CORPORATION
P.O. BOX 34535
SEATTLE, WA 98124-1535
USA
1-800-774-2678
WWW.COSTCO.COM

FOR CUSTOMER SERVICE
QUESTIONS OR COMMENTS
VISIT US @ GOURMIA.COM
INFO@GOURMIA.COM
OR CALL 888.552.0033
MON-THU 9:00AM TO 6:00PM ET
AND FRI 9:00AM TO 3:00PM ET
LANGUAGES SUPPORTED: ENGLISH, SPANISH

Gourmia