

Dionex ASE 150 Accelerated Solvent Extractor Operator's Manual

Document No. 065207
Revision 03
December 2011

© 2011 by Thermo Fisher Scientific Inc. All rights reserved.

Adobe, Acrobat, and Adobe Reader are registered trademarks of Adobe Systems, Incorporated in the United States and other countries.

The following are registered trademarks in the United States and possibly other countries: Hastelloy is a registered trademark of Haynes International, Inc. Perlast is a registered trademark of Precision Polymer Engineering, Ltd. Viton is a registered trademark of E. I. duPont de Nemours & Company.

PEEK is a trademark of Victrex PLC.

All other trademarks are the property of Thermo Fisher Scientific and its subsidiaries.

Thermo Fisher Scientific Inc. provides this document to its customers with a product purchase to use in the product operation. This document is copyright protected and any reproduction of the whole or any part of this document is strictly prohibited, except with the written authorization of Thermo Fisher Scientific Inc.

The contents of this document are subject to change without notice. All technical information in this document is for reference purposes only. System configurations and specifications in this document supersede all previous information received by the purchaser.

Thermo Fisher Scientific Inc. makes no representations that this document is complete, accurate or error-free and assumes no responsibility and will not be liable for any errors, omissions, damage or loss that might result from any use of this document, even if the information in the document is followed properly.

This document is not part of any sales contract between Thermo Fisher Scientific Inc. and a purchaser. This document shall in no way govern or modify any Terms and Conditions of Sale, which Terms and Conditions of Sale shall govern all conflicting information between the two documents.

Revision history: Revision 01 released April 2008

Revision 02 released September 2008

Revision 03 released December 2011

For Research Use Only. Not for use in diagnostic procedures.

1 • Introduction

1.1	Overview	1
1.2	About This Manual	2
1.2.1	Overview	2
1.2.2	Safety Messages and Notes	3
1.3	Safety and Regulatory Information	5
1.4	Safety Labels	5

2 • Description

2.1	Operating Features	7
2.1.1	Control Panel	9
2.1.2	Sample Cells and Rinse Cells	11
2.1.3	Collection Vessels	13
2.1.4	Solvent Reservoir	14
2.1.5	Waste Bottle	14
2.2	Rear Panel	15
2.3	Dionex ASE 150 Extraction Process	16
2.4	Method Control	19
2.5	Preprogrammed Methods	20

3 • Operation and Maintenance

3.1	Preparing to Run	25
3.1.1	Selecting and Preparing Solvent	25
3.1.2	Filling the Solvent Reservoir	29
3.1.3	Preparing the Sample	31
3.1.4	Installing the Cell Filter	34
3.1.5	Filling the Cell	37
3.1.6	Installing the Collection Vessel	39
3.1.7	Installing the Waste Bottle	41
3.2	Running	42
3.2.1	Selecting the Method	42
3.2.2	Selecting the Cell Size	42
3.2.3	Verifying the Cell Type	43
3.2.4	Starting the Run and Checking the Oven Status	43
3.2.5	Installing the Sample Cell in the Cell Holder	44
3.2.6	Completing the Run	45
3.3	Performing Post-Run Procedures	46
3.3.1	Cleaning the Sample Cells	46
3.3.2	Processing Extracts	46
3.4	Stopping a Run	47
3.5	Rinsing/Priming the System	48
3.6	Editing a Custom Method (Methods 1 through 24)	49
3.7	Developing a New Method	52
3.8	Performing Routine Maintenance	54

3.8.1 Daily Maintenance 54

3.8.2 Periodic Maintenance 54

3.8.3 Annual Maintenance 55

3.9 Shutting Down 55

4 • Troubleshooting

4.1 Error Messages 57

4.2 Liquid Leaks 65

4.3 Gas Leaks 67

4.4 Stopped System 67

5 • Service

5.1 Replacing Tubing and Fittings 69

5.2 Replacing the Cell End Cap Seal 69

5.3 Replacing the Cell End Cap O-Ring 73

5.4 Removing the Right-Side Panel 74

5.5 Replacing Pump Check Valve Cartridges 76

5.5.1 Before Beginning 76

5.5.2 Removing the Pump 76

5.5.3 Removing the Check Valves and Cartridges 77

5.5.4 Installing New Check Valve Cartridges 78

5.5.5 Reinstalling the Check Valves 78

5.5.6 Cleaning the Check Valves 78

5.5.7 Reinstalling the Pump 79

5.5.8	Completing the Procedure	79
5.6	Replacing Pump Seals	80
5.6.1	Before Beginning	80
5.6.2	Removing the Pump	80
5.6.3	Replacing the Piston High-Pressure Seal	80
5.6.4	Replacing the Piston Air Seal	82
5.6.5	Reinstalling the Pump and Completing the Procedure	84
5.7	Replacing the Pressure Relief Valve	85
5.8	Rebuilding the Static Valve	87
5.8.1	Removing the Static Valve from the System	89
5.8.2	Disassembling the Static Valve Body	91
5.8.3	Installing the New Seals	93
5.8.4	Reassembling the Static Valve	94
5.8.5	Reinstalling the Static Valve	98
5.9	Replacing the Source Needle	100
5.10	Replacing the Main Power Fuses	103

A • Specifications 105

A.1	Electrical	105
A.2	Environmental	105
A.3	Physical	106
A.4	Pneumatic	106
A.5	Front Panel Display and Keypad	106
A.6	Sample Cells	106

A.7	Collection Vessels	106
A.8	Interior Components	107
B	• Installation	109
B.1	Facility Requirements	109
B.2	Installation Instructions	110
B.2.1	Connecting the Nitrogen Gas Source	110
B.2.2	Connecting the Drain Hose	112
B.2.3	Checking the Oven Voltage Switches	112
B.2.4	Connecting the Power Cord	113
B.2.5	Checking Pressure Readings	114
B.2.6	Connecting the Solvent Reservoir	115
B.2.7	Installing the Waste Bottle	117
B.2.8	Adjusting the Cell Holder	118
B.2.9	Selecting Setup Options	120
B.2.10	Rinsing the System	122
C	• User Interface	127
C.1	Operational Screens	128
C.1.1	Menu Screen	128
C.1.2	Status Screen	129
C.1.3	Setup Screen	130
C.1.4	Method Editor Screen	131
C.2	Diagnostic Screens	133

C.2.1	Diagnostics Menu	133
C.2.2	Sensors Screen	134
C.2.3	Regulators Screen	135
C.2.4	Hydrocarbon Sensor Screen	136
C.2.5	Extraction Counters Screen	137
C.2.6	Moduleware Screen	137

D • Reordering Information 139

E • Theory of ASE 143

E.1	Introduction	143
E.2	Operation	145
E.3	Method Optimization	147
E.3.1	Sample Preparation	147
E.3.2	Extraction Parameters	150
E.4	Method Development	153
E.5	Selectivity in ASE	154
E.6	References	159

1.1 Overview

The Thermo Scientific Dionex™ ASE™ 150 Accelerated Solvent Extractor is a system for extracting either organic or inorganic compounds from a variety of solid or semisolid samples at a variety of pH values. The Dionex ASE 150 can be used with organic solvent, aqueous buffer, water, and small amounts of mineral acids. The Dionex ASE 150 accelerates the traditional extraction process by using solvent at elevated temperatures and pressures. Pressure is maintained in the sample cell to maintain the heated solvent in a liquid state during the extraction. After heating, the extract is rinsed from the sample cell into a collection vessel and is ready for analysis.

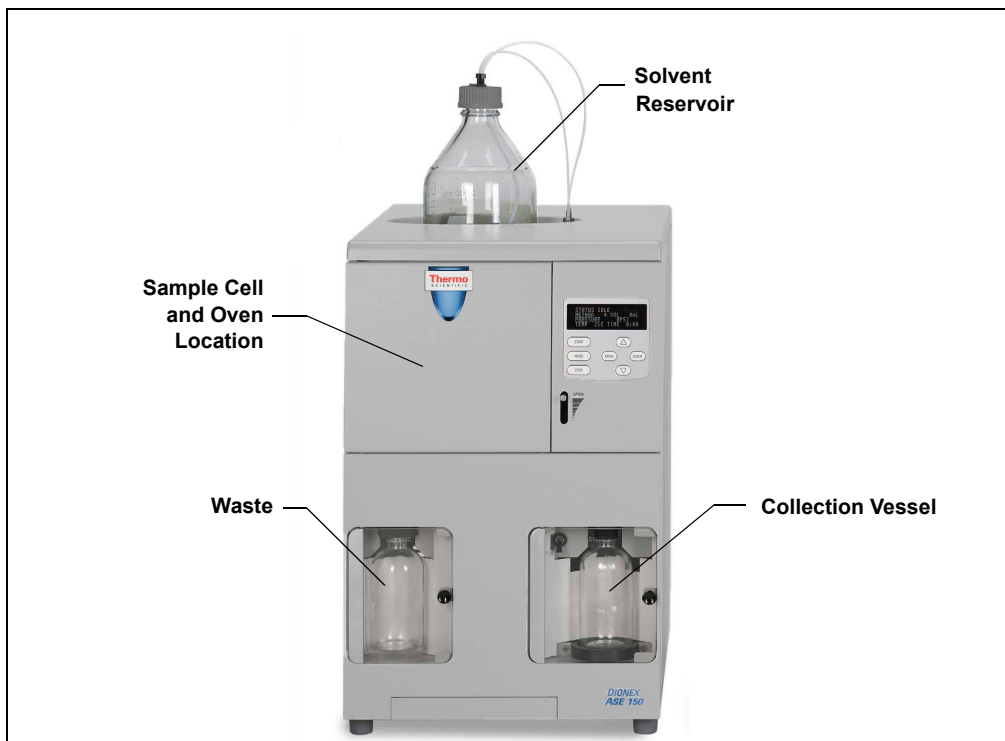

Figure 1-1. Thermo Scientific Dionex ASE 150 Accelerated Solvent Extractor

The Dionex ASE 150 is designed to minimize the amount of solvent used without sacrificing the speed of extraction or ease of operation. Samples are extracted one at a time, and the extraction process is typically completed in 15 to 25 minutes. All functions are controlled from the Dionex ASE 150 front panel.

Built-in safety diagnostics monitor the system during operation. If a problem occurs, the front panel displays an error message that identifies the problem. In addition, the method currently running is aborted and basic system functions are shut down until the situation is corrected.

1.2 About This Manual

1.2.1 Overview

The electronic version (i.e., PDF file) of the Dionex ASE 150 operator's manual contains numerous hypertext links that can take you to other locations within the file. These links include:

- Table of contents entries
- Index entries
- Cross-references (underlined in blue) to sections, figures, tables, etc.

If you are not familiar with how to navigate PDF files, refer to the Help system for Adobe® Acrobat® or Adobe Reader® for assistance.

Chapter 1 Introduction	Introduces the Dionex ASE 150; explains the conventions used in this manual, including safety-related information.
Chapter 2 Description	Describes Dionex ASE 150 operating features and the extraction process.
Chapter 3 Operation and Maintenance	Provides operating instructions and routine preventive maintenance procedures.
Chapter 4 Troubleshooting	Lists error messages and how to troubleshoot them; lists operating problems and how to resolve them.
Chapter 5 Service	Provides step-by-step instructions for routine service and parts replacement procedures that the user can perform.
Appendix A Specifications	Provides specifications and installation site requirements.

Appendix B Installation	Describes how to install the Dionex ASE 150.
Appendix C User Interface	Illustrates and describes the display screens on the Dionex ASE 150 front panel.
Appendix D Reordering Information	Lists spare parts for the Dionex ASE 150.
Appendix E Theory of ASE	Describes the theory behind performing extractions with ASE.

1.2.2 Safety Messages and Notes

This manual contains warnings and precautionary statements that can prevent personal injury and/or damage to the Dionex ASE 150 when properly followed. Safety messages appear in bold type and are accompanied by icons, as shown below.



Indicates an imminently hazardous situation which, if not avoided, will result in death or serious injury.



Indicates a potentially hazardous situation which, if not avoided, may result in death or serious injury.



Indicates a potentially hazardous situation which, if not avoided, may result in minor or moderate injury. Also used to identify a situation or practice that may seriously damage the instrument, but will not cause injury.



Indicates that the function or process of the instrument may be impaired. Operation does not constitute a hazard.

Messages d'avertissement en français



Signale une situation de danger immédiat qui, si elle n'est pas évitée, entraînera des blessures graves à mortelles.



Signale une situation de danger potentiel qui, si elle n'est pas évitée, pourrait entraîner des blessures graves à mortelles.



Signale une situation de danger potentiel qui, si elle n'est pas évitée, pourrait entraîner des blessures mineures à modérées. Également utilisé pour signaler une situation ou une pratique qui pourrait gravement endommager l'instrument mais qui n'entraînera pas de blessures.

Warnhinweise in Deutsch



Bedeutet unmittelbare Gefahr. Mißachtung kann zum Tod oder schwerwiegenden Verletzungen führen.



Bedeutet eine mögliche Gefährdung. Mißachtung kann zum Tod oder schwerwiegenden Verletzungen führen.



Bedeutet eine mögliche Gefährdung. Mißachtung kann zu kleineren oder mittelschweren Verletzungen führen. Wird auch verwendet, wenn eine Situation zu schweren Schäden am Gerät führen kann, jedoch keine Verletzungsgefahr besteht.

Notes

Informational messages also appear throughout this manual. These are labeled NOTE and are in bold type.

NOTE NOTES call attention to certain information. They alert the user to an unexpected result of an action, suggest how to optimize instrument performance, etc.

1.3 Safety and Regulatory Information

The Dionex ASE 150 was manufactured by Thermo Fisher Scientific Inc. at the following location: 527 Lakeside Drive, Sunnyvale, CA 94088-3603 U.S.A. The Dionex ASE 150 is designed for solvent extraction applications and should not be used for any other purpose. Operation of a Dionex ASE 150 in a manner not specified by Thermo Fisher Scientific may result in personal injury.

If you have a question regarding appropriate usage, contact Technical Support for Dionex products before proceeding. In the U.S. and Canada, call 1-800-346-6390. Outside the U.S. and Canada, call the nearest Thermo Fisher Scientific office.

1.4 Safety Labels

The cTUVus Mark safety label and the CE Mark label on the Dionex ASE 150 indicate that the Dionex ASE 150 is in compliance with the following standards.

EMC Susceptibility and Emissions

- EN 61326-1:2006

Safety

- CAN/CSA-C22.2 No. 61010-1:2004
- EN 61010-1:2001
- UL 3101-1/10.93
- UL 61010-1:2004

The symbols below appear on the Dionex ASE 150 or on Dionex ASE 150 labels.

 Alternating current

 Primary protective conductor terminal

 Secondary protective conductor terminal



Power supply is on



Power supply is off



Hot surface



Indicates a potential hazard. Refer to the operator's manual for an explanation of the hazard and how to proceed.

2.1 Operating Features

[Figure 2-1](#) illustrates the main operating features of the Thermo Scientific Dionex ASE 150 Accelerated Solvent Extractor.

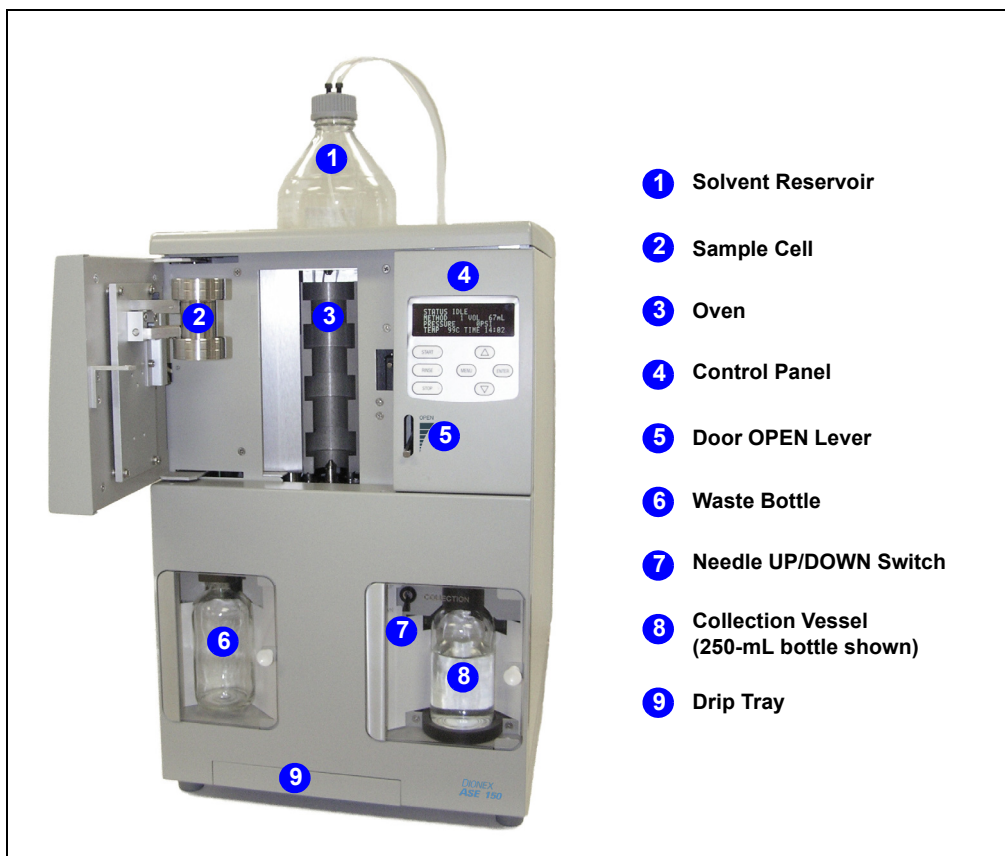

Figure 2-1. Dionex ASE 150 Operating Features

Solvent Reservoir

A 2-liter solvent reservoir is installed in a recess on top of the Dionex ASE 150. The recess contains a plastic liner that collects any solvent leaks or spills that may occur and directs them through a drain tube to the rear panel. A drain hose connects to the drain tube and is routed to a waste container.

Sample Cell

Before a sample is run or a rinse cycle is performed, a sample cell or rinse cell must be installed in the cell holder on the inside of the cell door. To access the cell holder, push down on the **OPEN** lever and then pull open the door.

Oven

The oven is located behind the cell door. This area also houses the AutoSeal™ tips, which seal the cell during a run.

Control Panel

The Dionex ASE 150 control panel includes a display screen and a membrane keypad, which are used to control Dionex ASE 150 operation.

Waste Bottle

The waste bottle is a 250-mL collection bottle that is sealed with a special built-in cap assembly.

Needle Up/Down Switch

The **UP/DOWN** toggle switch controls the position of the source and vent needles. When the needles are in the “down” position, they pierce the collection vessel septum. The source needle allows the extract to flow from the sample cell into the collection vessel. The vent needles allow displaced gases to escape to the waste bottle and the system vent.

Drip Tray

A pull-out drip tray is installed below the oven to collect any liquid leaks that may occur during a run or rinse cycle.

Collection Vessel

After each extraction, the collection vessel (either a 250-mL collection bottle or a 60-mL collection vial) contains solvent and the analytes extracted from the sample.

Safety Shields

The doors on the waste and collection vessel compartments are safety shields that protect operators in the rare case of a bottle or vial breakage. The doors must be closed for safe operation.

2.1.1 Control Panel

Use the control panel screen and buttons to control Dionex ASE 150 operation.

The screen displays status and operating information. You can edit any field on the screen that contains a blinking cursor. A field without a blinking cursor is for display only.

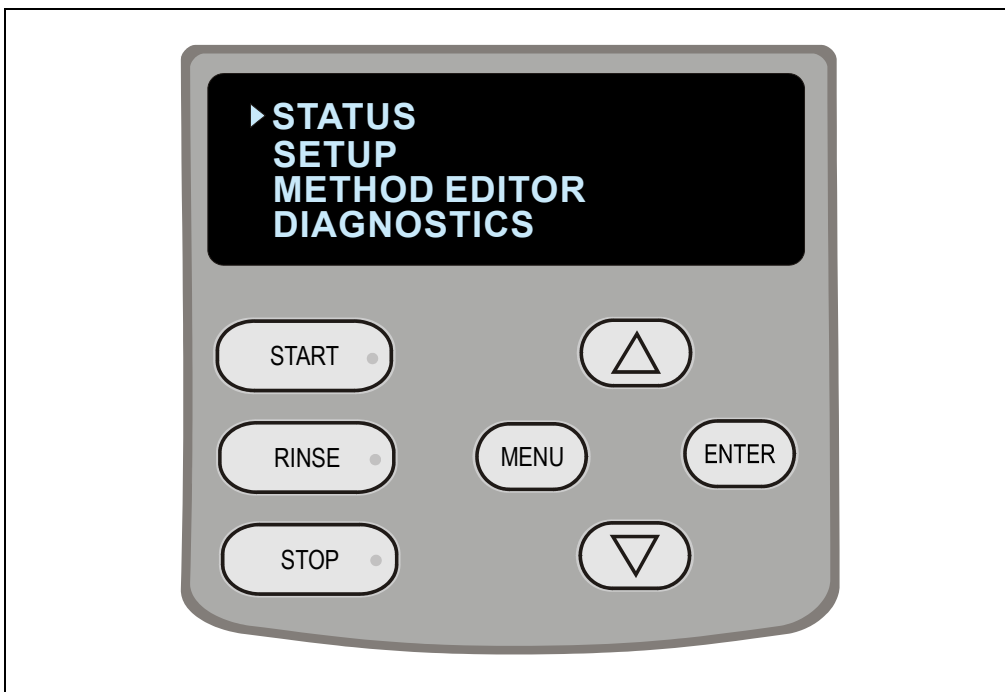

Figure 2-2. Dionex ASE 150 Control Panel





Button	Function
	<p>Starts the currently selected method. The LED starts flashing when the oven is within 1 °C of the set point, indicating it is okay to load the sample cell into the oven. During the method run, the LED is lighted, but does not flash. When the method finishes running (or is aborted), three beeps are emitted and the LED turns off. See Section 2.4 for details about methods.</p>
	<p>Starts a rinse cycle in which about 5 mL of solvent is pumped through the system. During the rinse cycle, the LED is lighted. When the rinse cycle is complete (or is aborted), three beeps are emitted and the LED turns off.</p> <p>Note: Always install a rinse cell and a collection vessel before starting a rinse cycle. See Section 3.5 for instructions.</p>
	<p>Interrupts the currently running method or rinse cycle and displays the ABORT screen. Pressing the button lights the LED. The LED turns off when you select an option on the ABORT screen. See Section 3.4 for details.</p>
	<p>Exits the screen currently displayed and returns to the screen one level up in the hierarchy. For example, if the METHOD EDITOR screen is displayed, pressing MENU returns you to the MENU screen. See Figure C-1 for an overview of the screens.</p> <p>When the cursor is in an editable field, pressing MENU discards any change and reverts to the previously selected parameter.</p>
	<p>Selects the field the cursor is currently pointing to. On the MENU or DIAGNOSTICS screen, this selects and displays a different screen. On other screens, pressing ENTER moves the cursor from the left margin to the first field in that line that can be edited; it also changes the normal cursor into the blinking editing cursor.</p> <p>When the cursor is in an editable field, pressing ENTER saves the parameter currently displayed in the field.</p>

Table 2-1. Dionex ASE 150 Control Panel Button Functions



Button	Function
	Moves the cursor, in the direction of the arrow, to the next selectable line on the display (if any).
	When the cursor is in an editable field, pressing an arrow button displays the next or previous parameter or numeric value allowed for the field. Note: Pressing and holding down an arrow button moves the cursor continuously through the allowed settings.

Table 2-1. Dionex ASE 150 Control Panel Button Functions (Continued)

2.1.2 Sample Cells and Rinse Cells

NOTE [Appendix D](#) contains part numbers for cells, bottles, vials, and other accessories.

Sample Cells

Cell Material	Sizes Available (mL)	Used For
Stainless steel	1, 5, 10, 22, 34, 66, and 100	Extractions with solvents
Zirconium	66 and 100	Extraction of basic or acidic matrices, and extractions with solvents

Sample cells consist of a cell body and two interchangeable caps, which are screwed onto each end of the cell body. The cell body and end caps are made of the same material. Inside each end cap is a frit in the same material as the cell, as well as a PEEK™ seal. During a run, the cell end caps are compressed by the oven to form a tight seal between the caps and the cell body.

IMPORTANT

Always tighten the cell end caps by hand. Use of a wrench or other tool can damage the cell, as well as the seals inside the cell end caps.

Each cell end cap contains an external O-ring. PTFE O-rings (P/N 049457, pkg. of 50) are standard. Use Viton® O-rings (P/N 056325, pkg. of 50) for dioxins and other high temperature applications.

IMPORTANT

If Viton external O-rings are installed on the cell end caps, do not use acetone or other ketones.

Rinse Cells

Rinse cells are similar in appearance to sample cells, but are blue in color. During a rinse cycle, solvent passes directly through the rinse cell and into the collection vessel. For more information about rinse cycles, see [Section 3.5](#).

The rinse cell size must be matched to the size of the sample cell, as indicated in the table below.

Use this rinse cell:	With this sample cell:
Short (P/N 060174)	1 mL, 5 mL, 10 mL, 22 mL, 34 mL
Medium (P/N 060175)	66 mL
Long (P/N 060176)	100 mL

Ordering Sample Cells in Other Sizes

To perform a run with a cell in a different size than the size originally ordered, order the cells from Thermo Fisher Scientific. You will also need to order the Startup Kit appropriate for the new cell size. For cell and Startup Kit part numbers, see [Appendix D](#).

Note that installation of a different sample cell size will require a few additional changes:

- Reposition the cell holder to accommodate the new sample cell size, if required. For instructions, refer to [Section B.2.8](#).
- Before beginning a run, specify the new cell size on the **SETUP** screen (see [Section C.1.3](#)).

2.1.3 Collection Vessels

The following collection vessels are available:

Collection Vessel	Part Number	Quantity
60-mL clear vials	048784	Pkg. of 72
60-mL amber vials	048781	Pkg. of 72
60-mL clear graduated vial, Class A	068226	1
60-mL clear graduated vial, Class B	068248	1
250-mL clear bottles	056284	Pkg. of 12
250-mL clear graduated bottle, Class A	068225	1
250-mL clear graduated bottle, Class B	068249	1



Before each run, carefully inspect all collection vessels for chips, scratches, or cracks. If a collection vessel shows any sign of damage, do not use it.

Use each nongraduated collection vessel once only. Graduated collection vessels may be used multiple times, provided they are undamaged.



La présence de fêlure ou d'égratignures sur les flacons de collecte doit être vérifiée avant chaque extraction. N'utilisez jamais un flacon endommagé.

Les flacons non gradués sont à usage unique. Les flacons gradués peuvent être réutilisés tant qu'ils sont intacts.



Untersuchen Sie vor jedem Lauf alle Sammelgefäße auf Abplatzungen, Kratzer oder Risse. Wenn ein Sammelgefäß eine Beschädigung aufweist, sollten Sie es nicht mehr verwenden.

Graduierte Sammelgefäße können mehrfach verwendet werden, vorausgesetzt sie weisen keine Beschädigung auf.



Use each collection vessel cap and septum once only. This prevents solvent leaks caused by piercing the septum in the cap multiple times.

An adapter (P/N 066392) is required to install a 60-mL vial in the collection vessel area. The adapter is included in the Startup Kits for 1-mL, 5-mL, 10-mL, 22-mL, and 34-mL sample cells.

The collection vessel caps (used with all bottles and vials) contain a solvent-resistant septum. During a run, the needle mechanism is lowered so that the needles pierce the septum, creating a liquid flow path from the

sample cell to the collection vessel. After a run, the collection vessel contains solvent and the analytes extracted from the sample.

2.1.4 Solvent Reservoir

The Dionex ASE 150 Ship Kit (P/N 066399) includes a 2-liter glass bottle with shatterproof plastic coating (P/N 045901) and a bottle cap assembly (P/N 068077) with tubing and fittings for the inlet and outlet connections. For instructions on how to install the solvent reservoir, see [Section 3.1.2](#).



Use only Thermo Fisher Scientific solvent reservoirs. These are glass bottles with a shatterproof plastic coating. To prevent operator injury, make sure the pressure applied to the bottles does not exceed 0.07 MPa (10 psi).



Utilisez uniquement des réservoirs à solvant Thermo Fisher Scientific. Ce sont des réservoirs en verre à revêtement incassable en plastique. Veillez à ce que la pression exercée sur ces réservoirs ne dépasse pas 0,07 MPa.



Verwenden Sie ausschließlich die Lösemittelbehälter von Thermo Fisher Scientific. Dabei handelt es sich um Glasbehälter mit einer splittersicheren Plastikbeschichtung. Vergewissern Sie sich, daß der Druck, der auf die Behälter ausgeübt wird, 0,07 MPa nicht übersteigt.



Never fill the solvent reservoir or disconnect the tubing connections to the solvent and gas connectors during a run or rinse cycle. At these times, the solvent reservoir is pressurized. If you remove the bottle cap, the Dionex ASE 150 may not operate to specification.

2.1.5 Waste Bottle

A 250-mL collection bottle (without the cap) is used to collect system waste. Three vent lines, one from the pressure relief valve and two from the needle mechanism, are connected to the built-in waste bottle cap. The waste bottle collects the small amounts of condensed solvent vented through these lines.

A vent outlet line is also connected to the waste bottle cap; gas is vented out this line to the rear panel. Connect the vent tubing (P/N 053514), provided in the The Dionex ASE 150 Ship Kit (P/N 066399), to the vent outlet on the rear panel (see [Figure 2-3](#)) and then route to a vent hood.

NOTE Check the waste bottle daily and empty whenever necessary.

2.2 Rear Panel

[Figure 2-3](#) illustrates the rear panel of the Dionex ASE 150.

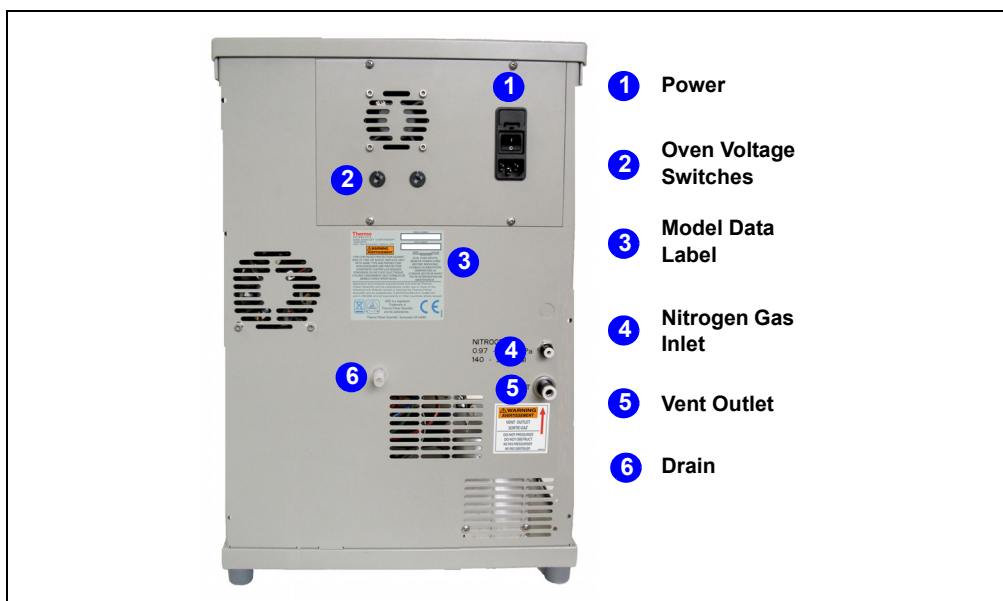

Figure 2-3. Dionex ASE 150 Rear Panel

- The **POWER** switch provides on/off control of the main power for the system. The power receptacle also includes the fuse holder. For instructions on how to replace the fuses, see [Section 5.10](#).
- The oven voltage switches must be set to match the voltage from the power source at the Dionex ASE 150 installation site. For instructions on how to set the switches, see [Section B.2.3](#).
- The model data label lists fuse and power information, as well as the Dionex ASE 150 serial number. You will be asked to provide the serial number when ordering replacement parts for the system.
- The **NITROGEN** connector is connected to a nitrogen supply regulated to between 0.97 and 1.38 MPa (140 and 200 psi); 1.03 MPa (150 psi) is recommended. For installation instructions, see [Section B.2.1](#).
- The **VENT** connector provides a connection for the vent outlet line. For installation instructions, see [Section B.2.1](#).

- The drain directs solvent spills from the bottle area on top of the Dionex ASE 150 to the rear panel. A drain hose connects to the fitting. For installation instructions, see [Section B.2.2](#).

2.3 Dionex ASE 150 Extraction Process

Preparing to Run an Extraction

The following steps are required before the Dionex ASE 150 can perform an extraction. Refer to [Chapter 3](#) for detailed instructions for each step.

- Fill the solvent reservoir.
- Prepare the sample and load it into the sample cell.
- Install the waste bottle and collection vessel.
- Select or create a method.
- Press the **START** button.
- Verify that the **STATUS** on the **STATUS** screen is **OVEN READY** (see [Figure 2-5](#)) and the LED on the **START** button is flashing.
- Install the sample cell in the cell holder and close the cell door.
- Press the **START** button.

Performing the Extraction

After you complete the preparation steps described on [page 16](#) and press **START** the second time, the Dionex ASE 150 performs the extraction. The extraction process consists of six main steps.

1. *Fill the cell with solvent*—the pump is turned on and the static valve is closed (see [Figure 2-4](#)). Solvent is pumped into the sample cell until the cell pressure reaches 10.35 MPa (1500 psi).

Thereafter, the static valve opens occasionally to maintain the pressure at 10.35 MPa (1500 psi).

2. *Heat the cell (equilibration)*—the temperature in the cell is heated to the set point specified in the method.
3. *Static extraction*—the cell remains filled with the solvent at the temperature set point.

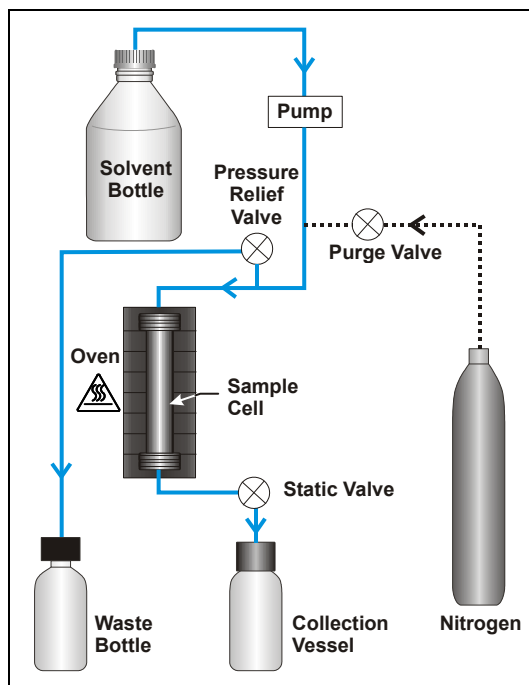

Figure 2-4. Extraction Process Schematic

4. *Rinse with fresh solvent*—the static valve opens and the extract flows into the collection vessel. Fresh solvent is pumped through the cell.
5. *Purge solvent from the system*—the purge valve opens and gas purges the remaining solvent from the cell into the collection vessel.
6. *Relieve pressure*—the pressure relief valve opens and residual pressure is released from the cell.

NOTE Static extraction and rinsing can be repeated multiple times.

Monitoring the Progress of a Run

To monitor the progress of a run, press **MENU**, move the cursor to **STATUS** (if necessary), and press **ENTER**. The **STATUS** screen appears (see [Figure 2-5](#)).

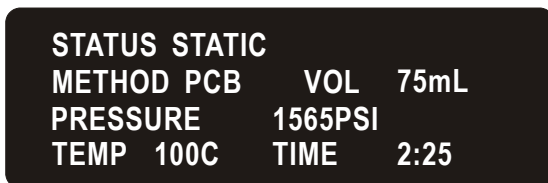

```
STATUS STATIC
METHOD PCB      VOL  75mL
PRESSURE        1565PSI
TEMP 100C      TIME  2:25
```

Figure 2-5. Status Screen Example

The **STATUS** screen operating parameters are updated in real time.

- **STATUS**—the current system status. During a run, the status field displays the following status states (in the order given): Oven Wait, Oven Ready, Load, Preheat (optional), Fill, Heat, Static, Rinse, Purge, Relief, Unload, and Idle.
- **METHOD**—the name or number of the current method.
- **VOL**—the approximate volume of solvent (in mL) delivered by the pump since the method started running.
- **PRESSURE**—the current sample cell pressure reading.
- **TEMP**—the temperature specified in the method.
- **TIME**—the elapsed time since the method started running.

2.4 Method Control

A *method* determines how the Dionex ASE 150 performs the sample extraction. Methods are defined on the **METHOD EDITOR** screen (see [Figure 2-6](#)).

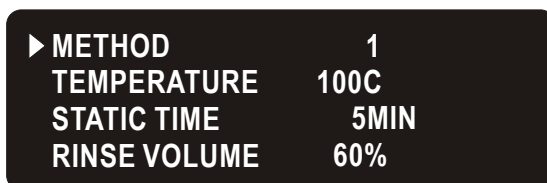

▶ METHOD	1
TEMPERATURE	100C
STATIC TIME	5MIN
RINSE VOLUME	60%

Figure 2-6. Method Editor Screen (Initial View)

The following method parameters define the method. See [Section C.1.4](#) for detailed descriptions of the method parameters.

- **TEMPERATURE**—the temperature at which to heat the cell.
- **STATIC TIME**—the number of minutes to maintain the cell contents (sample and solvent) at the temperature set point.
- **RINSE VOLUME**—the amount of solvent to rinse through the sample cell after the static extraction.
- **PURGE TIME**—the amount of time the cell is purged with nitrogen.
- **STATIC CYCLE**—the number of times the static extraction and rinse cycles are performed.
- **CELL TYPE**—the type of cell to use (stainless steel or zirconium).

Two types of methods are available:

- *Preprogrammed* methods are application-specific methods created by Thermo Fisher Scientific. These methods cannot be changed or deleted by the user. For a list of the parameters for each preprogrammed method, see [Section 2.5](#).
- *Custom* methods are user-programmable methods. All custom methods initially contain the default method parameters. You can modify these methods as required. For instructions on how to edit a custom method, see [Section 3.6](#).

2.5 Preprogrammed Methods

To help you quickly produce results with the Dionex ASE 150, Thermo Fisher Scientific provides nine preprogrammed methods. These methods are designated by three-letter abbreviations (see the table below).

Preprogrammed Method	Method Name
Semivolatiles	BNA
Total Fat (crude)	FAT
Chlorinated Herbicides	HRB
Organochlorine Pesticides	OCP
Organophosphorous Pesticides	OPP
Polychlorinated Biphenyls	PCB
Dioxins and Furans	PDF
Polymer Additives	PPE
Total Petroleum Hydrocarbons	TPH

The remainder of this section lists the recommended solvent and the operating conditions for each preprogrammed method. You cannot edit or delete a preprogrammed method.

BNA (Semivolatiles) Method Parameters	
Solvent	MeCl ₂ /Acetone (1:1, v/v)
Temperature	100 °C
Static Time	5 min
Rinse Volume	60%
Purge Time	100 sec
Static Cycle	1
Cell Type	Stainless steel

FAT (Total Fat) Method Parameters

Solvent	Hexane/Acetone (4:1)
Temperature	125 °C
Static Time	5 min
Rinse Volume	100%
Purge Time	60 sec
Static Cycle	3
Cell Type	Stainless steel

HRB (Chlorinated Herbicides) Method Parameters

Solvent	MeCl ₂ /Acetone (1:1) with 1% H ₃ PO ₄
Temperature	100 °C
Static Time	5 min
Rinse Volume	60%
Purge Time	100 sec
Static Cycle	1
Cell Type	Stainless steel

OCP (Organochlorine Pesticides) Method Parameters

Solvent	Hexane/Acetone (1:1, v/v)
Temperature	100 °C
Static Time	5 min
Rinse Volume	60%
Purge Time	100 sec
Static Cycle	1
Cell Type	Stainless steel

OPP (Organophosphorous Pesticides) Method Parameters

Solvent	MeCl ₂ /Acetone (1:1, v/v)
Temperature	100 °C
Static Time	5 min
Rinse Volume	60%
Purge Time	100 sec
Static Cycle	1
Cell Type	Stainless steel

PCB (Polychlorinated Biphenyls) Method Parameters

Solvent	Hexane
Temperature	100 °C
Static Time	5 min
Rinse Volume	60%
Purge Time	100 sec
Static Cycle	1
Cell Type	Stainless steel

PDF (Dioxins and Furans) Method Parameters

Solvent	Toluene
Temperature	200 °C
Static Time	5 min
Rinse Volume	60%
Purge Time	100 sec
Static Cycle	1
Cell Type	Stainless steel

PPE (Polymer Additives) Method Parameters

Solvent	2.5% Cyclohexane in Isopropyl Alcohol
Temperature	140 °C
Static Time	3 min
Rinse Volume	100%
Purge Time	60 sec
Static Cycle	3
Cell Type	Stainless steel

TPH (Total Petroleum Hydrocarbons) Method Parameters

Solvent	MeCl ₂ /Acetone (1:1, v/v)
Temperature	175 °C
Static Time	5 min
Rinse Volume	60%
Purge Time	100 sec
Static Cycle	1
Cell Type	Stainless steel

3 • Operation and Maintenance

3.1 Preparing to Run

3.1.1 Selecting and Preparing Solvent

Precautions



WARNING

Do not use solvents with an autoignition point below 200 °C. The table below lists some solvents that should *not* be used with the Dionex ASE 150. If you have a question about solvent suitability, contact Thermo Fisher Scientific.

Do Not Use These Solvents	Autoignition Point
Carbon disulfide: CS ₂	100 °C
Diethylether: (C ₂ H ₅) ₂ O	180 °C
1,4-dioxane: C ₄ H ₈ O ₂	180 °C



AVERTISSEMENT

N'utilisez pas de solvants ayant un point éclair inférieur à 200 °C. Le tableau ci-dessous liste quelques solvants qui ne doivent pas être utilisés avec l'ASE 150. Contactez Thermo Fisher Scientific si vous avez un doute concernant l'usage d'un solvant absent de la liste.

Solvants à ne pas utiliser	Point d'auto-inflammation
Disulfure de carbone: CS ₂	100 °C
Éther diéthylique: (C ₂ H ₅) ₂ O	180 °C
1,4-dioxane: C ₄ H ₈ O ₂	180 °C



WARNUNG

Verwenden Sie keine Lösungsmittel, deren Selbstentzündungstemperatur unter 200°C liegt. Die untenstehende Tabelle zeigt einige Lösungsmittel, die Sie nicht mit dem ASE 150 verwenden sollten. Bei Fragen zur Eignung von Lösungsmitteln wenden Sie sich bitte an Thermo Fisher Scientific.

Nicht zu verwendende Lösungsmittel	Selbstentzündungstemperatur
Kohlendisulfid: CS ₂	100 °C
Diethyläther: (C ₂ H ₅) ₂ O	180 °C
1,4-dioxan: C ₄ H ₈ O ₂	180 °C

Guidelines for Selecting and Preparing Solvents

- When developing a new method, select a solvent or solvent mixture that has a high solubility for the analytes of interest, but not for the sample matrix. If you have been using another method (Soxhlet, for example), use the same solvent with the Dionex ASE 150 that you used with the other method.
- Before running a preprogrammed method, refer to [Section 2.5](#) for the recommended solvent.
- Use HPLC-grade or pesticide-grade solvents.
- Use organic or aqueous solvents.
- Use single-component or multiple-component solvents.
- Solvents do not generally need to be degassed. Degas solvents only if the analyte of interest oxidizes easily.
- If Viton external O-rings are installed on the cell end caps, do not use acetone and other ketones.
- Although the zirconium components in the Dionex ASE 150 flow path are more resistant to acids and bases at elevated temperatures than other metallic materials, follow these guidelines to prevent degradation and ensure optimum performance:
 - a. As a general rule, strong mineral acids such as hydrochloric acid should not be used (at any concentration) as extraction solvents. This is because there are components in the flow path of the system (for example, the pump head) that are constructed of stainless steel and will corrode when used with strong acids. Sulfuric acid or nitric acid can be pumped as a solvent at concentrations less than 0.1% by volume. For additional details about acids that can be pumped as solvents, see [Table 3-1](#).

IMPORTANT

Using corrosive acids or bases can damage stainless steel cells and will void the product warranty.

- b. Weak bases such as ammonia can be used at small percentages (<5% by volume). Strong bases such as sodium hydroxide or potassium hydroxide can be pumped as extraction solvents at concentrations less than 0.1% by volume. For additional details about bases that can be pumped as solvents, see [Table 3-1](#).

- c. Weak acids such as phosphoric or acetic acid can be used as extraction solvents in small percentages (<5% by volume). Weak bases such as ammonia can be used at small percentages (<5% by volume).
- d. Noncorrosive additives such as buffers (acetate, phosphate, etc.) can be used as extraction solvents at moderate percentages.
- e. In some cases, nitric or hydrochloric acid can be added directly to the sample before it is placed into a zirconium cell (not a stainless steel cell). For example, 1 to 2 mL of 5% to 10% HCl can be added directly to a soil sample before it is loaded into a zirconium cell for extraction.
- f. [Table 3-1](#) lists the allowable concentrations for several acids and bases. If a sample needs to be treated with acids stronger than the concentrations here, pretreat the sample with the concentrated acid before loading it into a zirconium cell (not a stainless steel cell). For more details about sample preparation, see [Section 3.1.3](#).

Acid or Base Concentration	Okay to pump from solvent reservoir? (Okay to use SST or Zr cells)	Add to sample and transfer to Zr cell? (Do not use SST cells)	Add to sample matrix with ASE Prep CR and transfer to Zr cell? (Do not use SST cells)
HCl 8 M	No	No	Yes
HCl 10%	No	Yes	Yes
HCl 0.1 M	No	Yes	Yes
NaOH 8 M	No	No	N/A
NaOH 10%	No	Yes	N/A
NaOH 0.1 M	Yes	Yes	N/A
H ₂ SO ₄ 8 M	No	No	Yes
H ₂ SO ₄ 10%	No	Yes	Yes
H ₂ SO ₄ 5% solution	Yes	Yes	Yes

Table 3-1. Guidelines for Use of Acids and Bases with the Dionex ASE 150

Acid or Base Concentration	Okay to pump from solvent reservoir? (Okay to use SST or Zr cells)	Add to sample and transfer to Zr cell? (Do not use SST cells)	Add to sample matrix with ASE Prep CR and transfer to Zr cell? (Do not use SST cells)
H ₂ SO ₄ 0.1 M	Yes	Yes	Yes
KOH 8 M	No	No	N/A
KOH 10%	No	Yes	N/A
KOH 0.1 M	Yes	Yes	N/A
HNO ₃ 8 M	No	No	Yes
HNO ₃ 10%	Yes	Yes	Yes
HNO ₃ 0.1 M	Yes	Yes	Yes
NH ₄ OH 8 M	No	No	N/A
NH ₄ OH < 5%	Yes	Yes	N/A
NH ₄ OH 0.1 M	Yes	Yes	N/A
Trifluoroacetic acid < 5%	Yes	Yes	Yes
Acetic acid < 5%	Yes	Yes	Yes
Phosphoric acid < 5%	Yes	Yes	Yes

Table 3-1. Guidelines for Use of Acids and Bases with the Dionex ASE 150

IMPORTANT

If acids, bases, salts, or buffers are used as extraction solvents, rinse the system with 100% polar organic solvent (for example, acetone or methanol) or distilled water before turning off the power.

3.1.2 Filling the Solvent Reservoir



Use only Thermo Fisher Scientific solvent reservoirs. These are glass bottles with a plastic, shatterproof coating. Make sure the pressure applied to the bottles does not exceed 0.07 MPa (10 psi).



Utilisez uniquement des réservoirs à solvant Thermo Fisher Scientific. Ce sont des réservoirs en verre à revêtement incassable en plastique. Veillez à ce que la pression exercée sur ces réservoirs ne dépasse pas 0,07 MPa.



Verwenden Sie ausschließlich die Lösemittelbehälter von Thermo Fisher Scientific. Dabei handelt es sich um Glasbehälter mit einer splittersicheren Plastikbeschichtung. Vergewissern Sie sich, daß der Druck, der auf die Behälter ausgeübt wird, 0,07 MPa nicht übersteigt.



Never fill the solvent reservoir or disconnect the tubing connections to the solvent and gas connectors (see [Figure 3-1](#)) during a run or rinse cycle. At these times, the solvent reservoir is pressurized. If you remove the bottle cap when the solvent reservoir is pressurized, the Dionex ASE 150 may not operate to specification.

1. If you plan to run a preprogrammed method, refer to [Section 2.5](#) for the recommended solvent. If you plan to run a custom method, review the solvent selection guidelines in [Section 3.1.1](#).
2. Fill the solvent reservoir with prepared solvent to the level indicated in [Figure 3-1](#).

NOTE The solvent level in the reservoir must remain below the gas line. This prevents solvent from coming into contact with the pneumatic valves.

3. Place the bottle in the recess on top of the system.
4. Insert the solvent and gas lines extending from the underside of the bottle cap assembly into the bottle (see [Figure 3-1](#)). Make sure the end-line filter on the solvent line rests on the bottom of the bottle.
5. Hand-tighten the lock ring cap securely over the stopper.
6. If they are not already connected, screw the solvent line fitting into the solvent connector on the Dionex ASE 150 and then push the gas line fitting into the gas connector.

NOTE Always connect the solvent line to the solvent connector first, and then the gas line to the gas connector. If you need to disconnect the lines, reverse the order. It is not necessary to disconnect the solvent and gas lines before refilling the bottle.

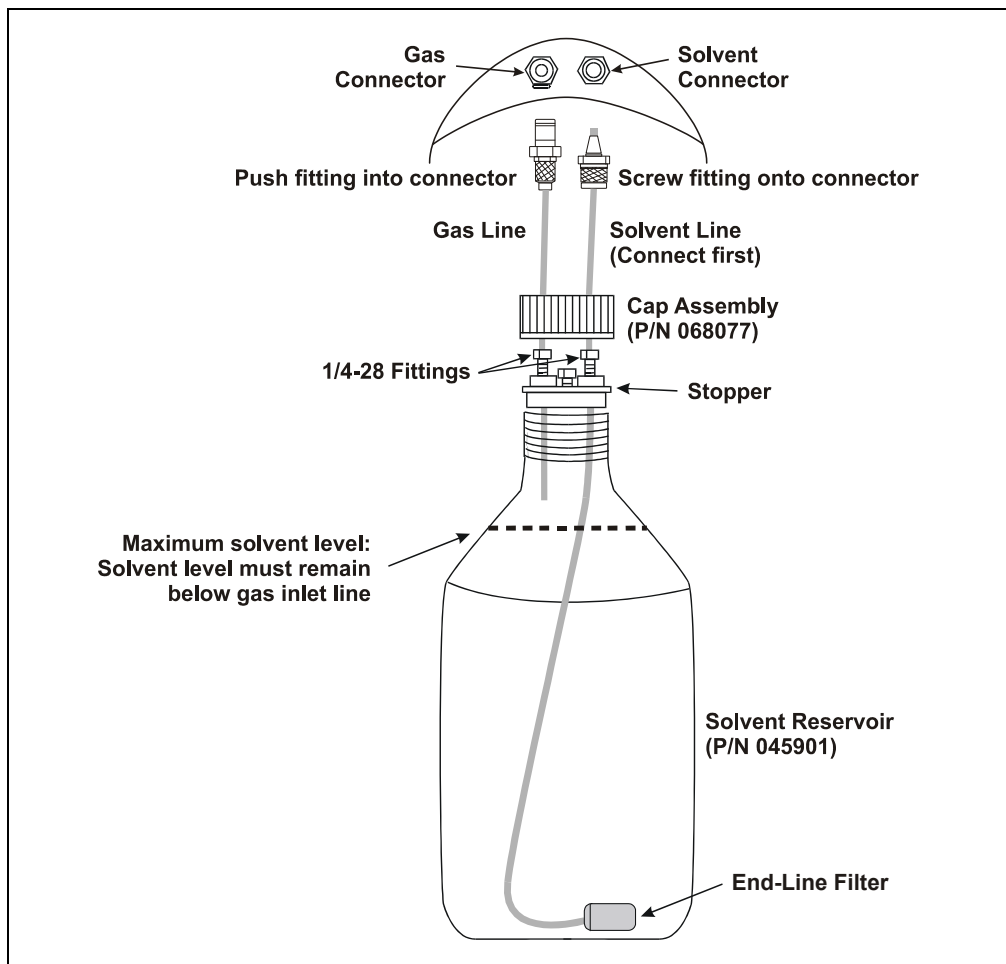

Figure 3-1. Solvent Reservoir Connections

3.1.3 Preparing the Sample

If you have successfully followed a particular sample pretreatment procedure for another extraction method, continue using this procedure with the Dionex ASE 150. If you have never run an extraction—or if you are preparing a new sample—follow the guidelines here. This section discusses two sample pretreatment procedures:

- Samples that are dry, wet, or liquid should be mixed with a drying or dispersing agent before being loaded into the cells.
- Samples with large particle sizes should be ground before being loaded into the cells.

NOTE: Most problems with the ASE (accelerated solvent extraction) process are caused by errors made during sample preparation. To obtain high quality analytical results, pay careful attention to the sample preparation phase of the method. For more details, see [Appendix E](#).

Guidelines for Selecting a Drying or Dispersing Agent

- Although sodium sulfate is readily available, it should not be used in Dionex ASE 150 cells. The use of sodium sulfate with very wet samples (30% moisture) will result in clogging of system components (such as the solvent line or needles) with recrystallized sodium sulfate. This occurs particularly if a mixed solvent with a polar component such as methanol or acetone is used. In these cases, use pelletized diatomaceous earth (DE) (P/N 062819) as a drying agent and mix it with the sample before loading into the sample cell (see the sample preparation guidelines on [page 32](#)). (Alternatively, DE can be used as a drying agent in the cell in place of sodium sulfate for all levels of moisture.)
- For very wet samples, regardless of which drying agent is used, you may add sodium sulfate to the collection vessels after collection and then pass the extracts through either a drying column or drying cartridge to dry the extract completely. At the temperatures used during Dionex ASE 150 extractions, more water is co-extracted than with other extraction procedures. To ensure good analyte recovery, thoroughly rinse the sodium sulfate out of the collection vessel and the cleanup column.

- If a sample needs to be treated with acids stronger than the concentrations listed in [Table 3-1](#), pretreat the sample with the concentrated acid before loading it into the cell. After the pretreatment, mix the sample with ASE Prep CR Resin (P/N 080024) to partially neutralize the acid to approximately 0.1 M. The sample may need to be mixed with pelletized diatomaceous earth (DE) (P/N 062819) to absorb water, depending on how much acid was used to pretreat the sample.

For example, if a food sample is treated with 10 mL of 8 M HCl, mix the liquid hydrolysate with 30 to 40 g of ASE Prep CR and 15 g of DE. When the sample is thoroughly mixed, add it to the zirconium cell. **(Do not use a stainless steel cell.)** Use this ratio of acid to ASE Prep CR whenever using strong acids for pretreatment of samples.

If you have any questions about compatibility of an acid or base, please contact Thermo Fisher Scientific.

Guidelines for Sample Preparation with a Drying or Dispersing Agent

The following mixtures are recommendations only; adjust the proportions as required.

- If the sample appears dry, use this mixture:
4 grams sample to 1 gram DE
Mix the sample and the DE thoroughly in a small bottle, beaker, or mortar.
- If the sample appears wet, use this mixture:
4 grams sample to 2 grams DE
Mix the sample and the DE thoroughly in a small bottle, beaker, or mortar.
- If the sample is pure liquid, use 5 grams sample to 3 grams DE.
Fill the cell with DE and then add the sample.

NOTE Certain pure liquid samples may be mixed with drying or dispersing agents other than DE. For a current list of approved materials, contact Thermo Fisher Scientific.

Guidelines for Grinding

- For an efficient extraction to occur, the solvent must make contact with the target analytes. The more surface area that can be exposed in a sample, the faster extraction will occur. Therefore, samples with large particle sizes should be ground prior to extraction. Often a large, representative sample can be ground, and then weighed portions of the ground sample can be used for extraction.
- Soil and sediment samples usually do not need to be ground, but it may be necessary to remove stones or sticks from the samples prior to extraction.
- Polymer samples must be in a ground state for an efficient extraction of additive compounds. Materials such as polymers and rubbers are best ground at reduced temperatures; for example, liquid nitrogen.
- Animal or plant tissue samples can be homogenized using any procedure such as a blender or tissue homogenizer.

Sample Preparation by Grinding

Grind the sample with any of the following tools: a conventional mortar and pestle, an electric grinder, or an electric mill. For the most efficient extraction, grind until particles are smaller than 1 mm.

3.1.4 Installing the Cell Filter

A disposable filter must be installed in the bottom end cap of the sample cell before sample is loaded. The filter prevents blockage of the frit in the bottom cap. For installation instructions, see [page 34](#) and [page 35](#). Refer to the information here to determine the appropriate filter material and size.

Cell filters are available in two materials:

- Use *cellulose* filters for most extraction methods that use organic solvents.
- Use *glass-fiber* filters for aqueous extractions, where cellulose may provide inadequate filtration or may interfere with the analytical technique.

Cell filters are available in two sizes:

- Use 27-mm filters for 1-mL, 5-mL, 10-mL, or 22-mL cells.
- Use 30-mm filters for 34-mL, 66-mL, or 100-mL cells.

Each Dionex ASE 150 Startup Kit includes a package of 100 cellulose filters, in the size appropriate for the sample cell size to be used. For information about reordering filters or ordering filters in a different material or size, refer to [Appendix D](#).

To install a 27-mm filter in a 1-, 5-, 10-, or 22-mL cell:

1. Unscrew the bottom cap from the cell body.

To identify the cell top and bottom, designate the end of the cell with the grooved band around the body as the cell top and the end with the Thermo Scientific logo, serial number, and size as the bottom (see [Figure 3-2](#)).

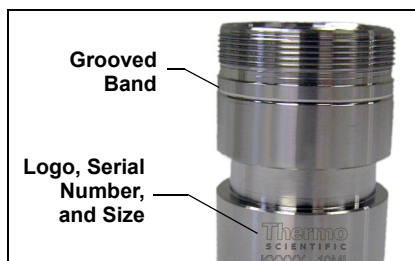

Figure 3-2. Sample Cell Orientation (Smaller Cells)

2. Place a 27-mm filter in the center of the cell bottom cap (see [Figure 3-3](#)).
3. To prevent leaks, check that no part of the filter overlaps onto the PEEK seal.



Figure 3-3. Installing a 27-mm Cell Filter

4. Carefully place the cell body over the bottom cap, screw the body onto the cap, and hand-tighten.

IMPORTANT

Always tighten the cell end caps by hand. Use of a wrench or other tool can damage the cell, as well as the seals inside the cell end caps.

To install a 30-mm filter in a 34-, 66-, or 100-mL cell:

1. Unscrew the top cap from the cell body and verify that a cap is installed on the bottom of the cell.

To identify the cell top and bottom, designate the end of the cell with the grooved band around the body as the cell top and the end with the Thermo Scientific logo, serial number, and size as the bottom (see [Figure 3-4](#)).



Figure 3-4. Sample Cell Orientation (Larger Cells)

IMPORTANT

Always tighten the cell end caps by hand. Use of a wrench or other tool can damage the cell, as well as the seals inside the cell end caps.

IMPORTANT

Do not place the 30-mm filter in the bottom cap before installing the cap; this creates an improper seal and allows leaks.

2. Follow the steps in [Figure 3-5](#) to install the 30-mm filter.



Figure 3-5. Installing a 30-mm Cell Filter in a 34-, 66-, or 100-mL Cell

NOTE The procedure for installing 30-mm filters in stainless steel and zirconium cells is the same. The photos in [Figure 3-5](#) show a zirconium cell.

3.1.5 Filling the Cell

Precautions:

- When filling the cell with sample, keep the threads on the cell body and end cap as clean as possible to prevent thread fouling and extend the life of the cell.
- Also make sure that the ends of the cell body and the seals in the end caps are clean; if debris remains here, it will damage the cell body and/or allow leaks during the run.

To fill a cell:

1. Use the funnel provided in the Dionex ASE 150 Startup Kit to carefully load the sample into the top of the sample cell. To accommodate different sample cell sizes, three funnels (with different inner diameters) are available (see [Figure 3-6](#)).

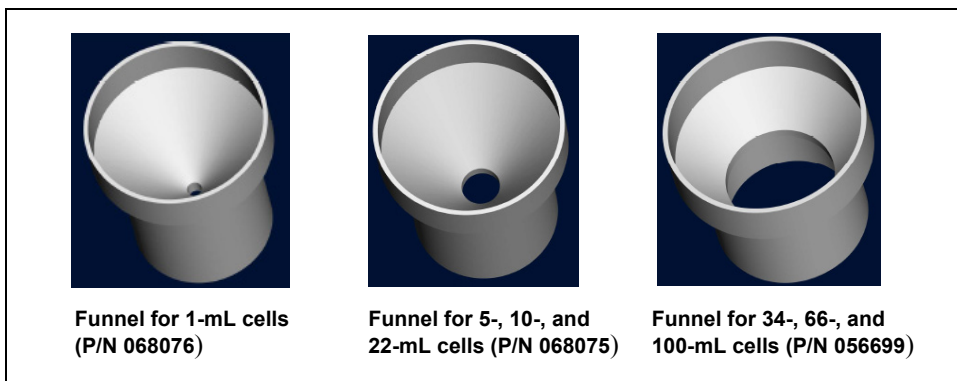

Figure 3-6. Sample Funnels

2. (*Optional*) To reduce the amount of solvent used during the run, fill any void volume in the cell with an inert material such as Ottawa sand (Fisher S23-2).
3. Using a soft brush or cloth, wipe all debris off the threads of the top cell end cap.
4. Screw the top cap onto the cell body. Hand-tighten the cap.

IMPORTANT

Always tighten the cell end caps by hand. Use of a wrench or other tool can damage the cell, as well as the seals inside the cell end caps.

5. Check the ends of each cell end cap to verify that the O-rings are in place and are in good condition (see [Figure 3-7](#)).
 - If an O-ring is dislodged, press it into place, using the O-ring insertion tool (P/N 049660), provided in the Dionex ASE 150 Ship Kit (P/N 066399).

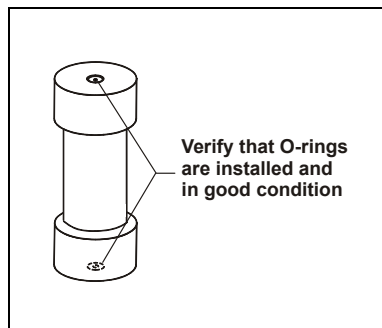

Figure 3-7. Inspecting Cell O-Rings

- If an O-ring is *missing*, place a new O-ring over the opening in the end of the cell end cap. Press the O-ring into place, using the O-ring insertion tool (see [Figure 3-8](#)). For information about ordering O-rings, refer to [Appendix D](#).
- If any O-ring has a hole size of less than 0.5 mm, replace it. If a white PTFE (polytetrafluoroethylene) O-ring is discolored, replace it (see the following instructions).

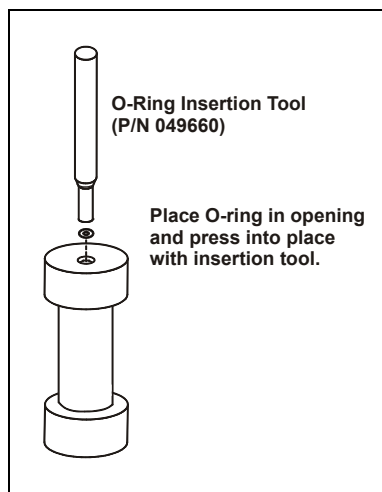

Figure 3-8. Installing a Cell End Cap O-Ring

To replace a cell end cap O-ring:

IMPORTANT

Be careful not to scratch the interior of the cell end cap when installing or removing the cell O-ring. Scratches on the sealing surface will prevent the O-ring from sealing properly and may result in leaks during operation.

1. Locate the small flathead screwdriver (P/N 046985) in the Dionex ASE 150 Ship Kit (P/N 066399).
2. Insert the tip of the screwdriver into the end cap and *carefully* pick out the O-ring. (This may be easier to do if you first remove the cap from the cell body and place it flat on the workbench.)

- Place a new O-ring over the opening in the end of the cell end cap. Press the O-ring into place using the O-ring insertion tool (see [Figure 3-8](#)).

3.1.6 Installing the Collection Vessel

During the extraction process, sensors determine if a collection vessel is present and, if so, whether it is full. If you want to attach a label to a collection vessel, or write an identification name or number on it, be sure the location does not block the sensors. [Figure 3-9](#) shows the acceptable locations for this information.

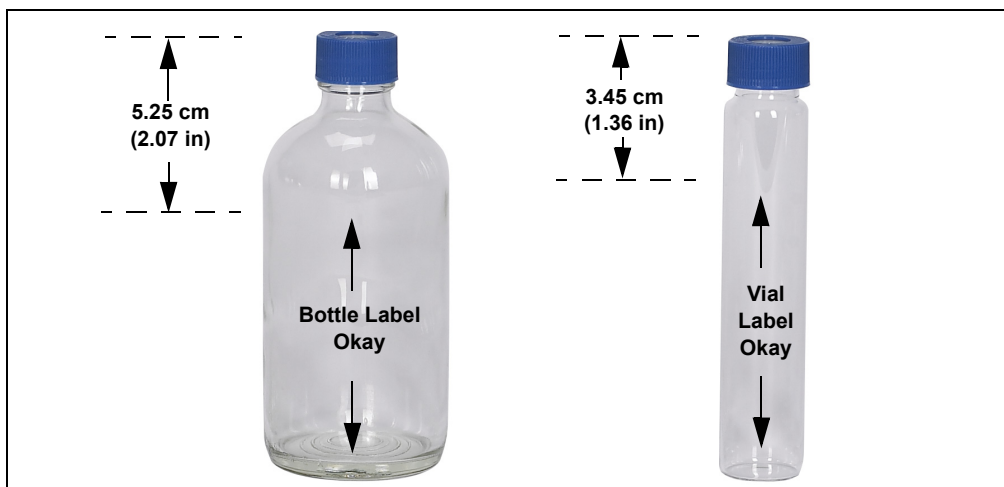

Figure 3-9. Acceptable Locations for Collection Vessel Labels



Before each run, carefully inspect all collection vessels for chips, scratches, or cracks. If a collection vessel shows any sign of damage, do not use it.

Use each nongraduated collection vessel once only. Graduated collection vessels may be used multiple times, provided they are undamaged.



La présence de fêlure ou d'égratignures sur les flacons de collecte doit être vérifiée avant chaque extraction. N'utilisez jamais un flacon endommagé.

Les flacons non gradués sont à usage unique. Les flacons gradués peuvent être réutilisés tant qu'ils sont intacts.



Untersuchen Sie vor jedem Lauf alle Sammelgefäße auf Abplatzungen, Kratzer oder Risse. Wenn ein Sammelgefäß eine Beschädigung aufweist, sollten Sie es nicht mehr verwenden.

Graduierte Sammelgefäße können mehrfach verwendet werden, vorausgesetzt sie weisen keine Beschädigung auf.

IMPORTANT

Use each collection vessel cap and septum once only. This prevents solvent leaks caused by piercing the septum in the cap multiple times.

1. Open the collection vessel compartment door and toggle the needle switch to the **UP** position (see [Figure 3-10](#)).
2. If you are using a 60-mL collection vial, place the vial into the adapter (P/N 066392) and then place the adapter on the collection bottle holder (see [Figure 3-10](#)). If you are using a 250-mL collection bottle, place the bottle directly on the collection bottle holder.
3. Toggle the needle switch to the **DOWN** position and close the door.

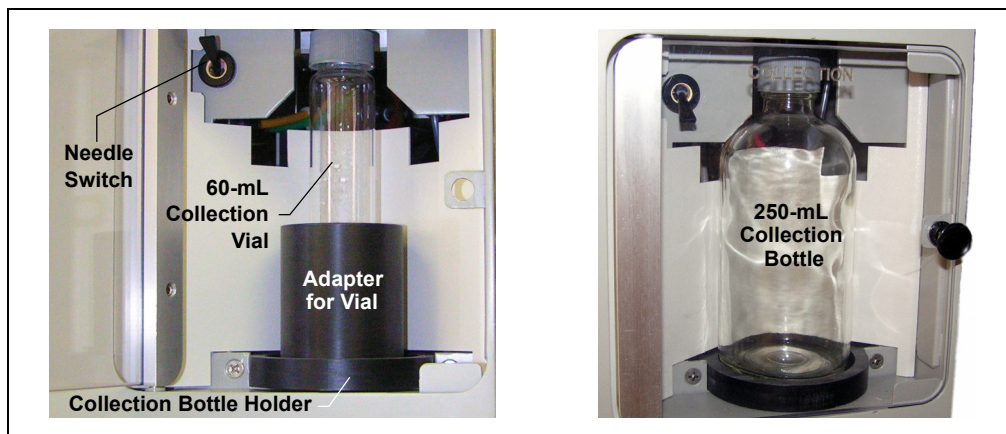

Figure 3-10. Installing the Collection Vessel

3.1.7 Installing the Waste Bottle

Use a 250-mL collection bottle (without a cap) for the waste bottle.

1. Open the waste compartment door.
2. Tilt the waste bottle at a slight angle and position it below the built-in bottle cap.
3. While being careful not to bend the tubing that extends from the bottle cap, insert the bottle into the bottle cap.
4. Tilt the cap and bottle toward you and screw the bottle into the cap.
5. Hand-tighten the bottle onto the cap to ensure a good seal.
6. Release the bottle, allowing it to swing gently into place.
7. Close the waste compartment door.



Figure 3-11. Installing the Waste Bottle

3.2 Running

3.2.1 Selecting the Method

1. Press **MENU** to display the **MENU** screen (see [Figure 3-12](#)).

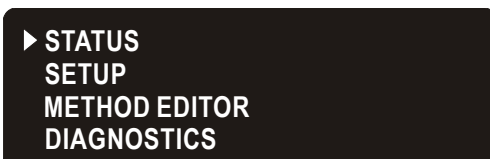

Figure 3-12. Menu Screen

2. Move the cursor to **SETUP** and press **ENTER**. The **SETUP** screen appears (see [Figure 3-13](#)).

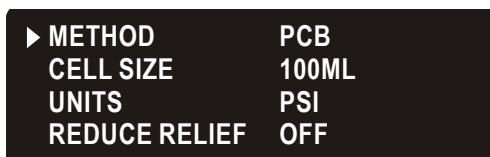

Figure 3-13. Setup Screen

3. Press **ENTER** to move the cursor to the method editing field.
4. Press an arrow button to step through the custom method numbers and the names of the preprogrammed methods. To edit a custom method, see [Section 3.6](#). For descriptions of the preprogrammed methods, refer to [Section 2.5](#).
5. When the method required for the run is displayed, press **ENTER**.

3.2.2 Selecting the Cell Size

The Dionex ASE 150 determines various internal operating parameters (for example, the rinse volume) based on the cell size selected on the **SETUP** screen (see [Figure 3-13](#)). If the selected cell size does not match the size of the cell in use, select the correct size:

1. On the **SETUP** screen, move the cursor to **CELL SIZE** and press **ENTER**.
2. Press an arrow button to step through the cell sizes.
3. When the correct cell size is displayed, press **ENTER**.

4. Press **MENU** to return to the **MENU** screen.

3.2.3 Verifying the Cell Type

If you are going to run a custom method (method numbers 1 through 24), verify that the correct cell type is selected in the method.

1. On the **MENU** screen, move the cursor to **METHOD EDITOR** and press **ENTER**. The **METHOD EDITOR** screen (see [Figure 3-18](#)) is displayed.
2. Press the down arrow until **CELL TYPE** is displayed.
3. If the selected cell type is incorrect, press **ENTER** and then press an arrow button to select the other type. Press **ENTER**.

For details about editing custom methods, see [Section 3.6](#).

3.2.4 Starting the Run and Checking the Oven Status

1. On the **MENU** screen, move the cursor to **STATUS** and press **ENTER**. The **STATUS** screen (see [Section C.1.2](#)) appears.
2. Press **START**, and then observe the **STATUS** field. If the **STATUS** is **OVEN WAIT**, the oven temperature is not yet at the set point.

IMPORTANT

Do not install the cell while the status is **OVEN WAIT**. Installing the cell before the oven is ready will cause an error.

3. When the oven is within 1 °C of the set point, the **STATUS** field changes to **OVEN READY** (see [Figure 3-14](#)) and the LED on the **START** button begins flashing. You can now install the cell in the cell holder.

STATUS	OVEN READY		
METHOD	PCB	VOL	0mL
PRESSURE	0PSI		
TEMP	100C	TIME	5:00

Figure 3-14. Status Screen

IMPORTANT

Always install the cell in the cell holder. If you install the cell directly in the oven, the cell door will not close and the run will not start.

3.2.5 Installing the Sample Cell in the Cell Holder

The installation procedure is the same for rinse and sample cells. A sample cell is shown in the photos.

1. Open the cell door.
2. While holding the cell at a slight angle, position the bottom end cap under the bottom latch of the cell holder.

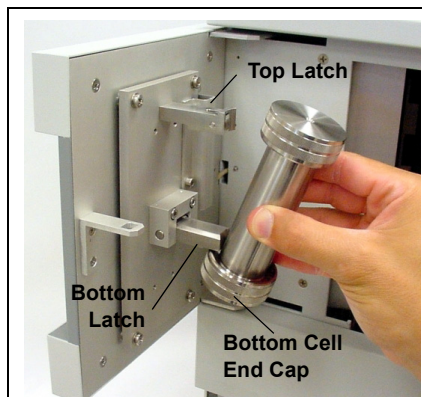

3. Raise the cell so that the bottom end cap lifts the bottom latch.



4. Straighten the cell until it is vertical, and then lower it until the top end cap rests on the top latch of the cell holder.

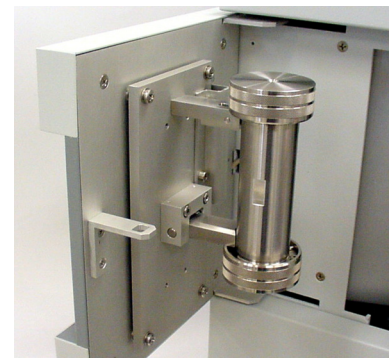

5. Close the cell door.

Figure 3-15. Installing a Sample Cell

3.2.6 Completing the Run

1. Verify that a collection vessel and a waste bottle are installed (see [Section 3.1.6](#) and [Section 3.1.7](#)); the needle switch is down; and the cell, collection vessel, and waste bottle doors are closed.
2. Press **START** to begin the run. A typical run takes 15 to 25 minutes.



Do not attempt to open the cell door while a run is in progress.



N'ouvrez pas la porte pendant une extraction.



Halten Sie die Tür während der Extraktion geschlossen.

3. Monitor the run on the **STATUS** screen (see [Figure 3-14](#)).
4. When the run is complete, three beeps are emitted, the **START** LED turns off, and the **STATUS** screen displays **IDLE**.
5. Toggle the needle switch to the **UP** position and remove the collection vessel containing the extract from the holder. Refer to [Section 3.3](#) for post-run procedures.



Cells are extremely hot after a run. Be especially cautious with cells that have been heated over 50 °C (122 °F).



Les cellules sont extrêmement chaudes après une extraction. Faites particulièrement attention aux cellules qui ont été chauffées à plus de 50 °C.



Die Zellen sind nach ihrer Entnahme sehr heiß. Seien Sie besonders vorsichtig, wenn Zellen über 50°C erhitzt wurden.

6. Put on the thermal gloves (P/N 060372) provided in the Dionex ASE 150 Ship Kit (P/N 066399).
7. Remove the cell from the cell holder and place it on the cell rack (P/N 059927) to cool.
8. Close the cell door until the next run, to save energy and prevent anyone from accidentally touching a hot surface.

3.3 Performing Post-Run Procedures

3.3.1 Cleaning the Sample Cells



Cells are extremely hot after an extraction. Allow cells to cool for at least 15 minutes before handling. Be especially cautious with cells that have been heated over 50 °C (122 °F).



Les cellules sont extrêmement chaudes après une extraction. Laissez-les refroidir pendant au moins 15 minutes avant de les manipuler. Faites particulièrement attention aux cellules qui ont été chauffées à plus de 50 °C.



Die Zellen sind nach ihrer Entnahme sehr heiß. Lassen Sie die Zellen mindestens 15 Minuten abkühlen. Seien Sie besonders vorsichtig, wenn Zellen über 50 °C erhitzt wurden.

After use, empty the cells and rinse the cell bodies and end caps with water or organic solvent.

- Both stainless steel and zirconium cell bodies (but not cell end caps) can be cleaned in a dishwasher or high temperature cleaning unit. Do not exceed 200 °C (392 °F) when performing high temperature cleaning.
- For most applications, simply rinsing the end caps is sufficient. If necessary, disassemble the end caps (see [Section 5.2](#)) and sonicate or soak in solvent to clean them.
- Do not use detergent to clean the end cap frits.

3.3.2 Processing Extracts

The composition of the extracts generated by the Dionex ASE 150 is very close to that generated by Soxhlet and other standard solid-liquid extraction techniques when using the same solvent. Use the same analytical method for Dionex ASE 150 extracts that you employed for extracts obtained from other techniques.

3.4 Stopping a Run

To stop a run before the end of the method, press **STOP**. This stops the run and displays the **ABORT** screen (see [Figure 3-16](#)).

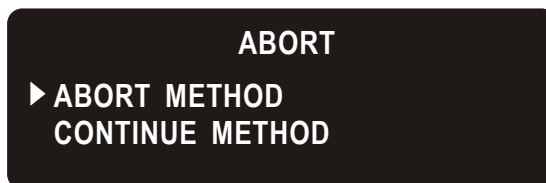

Figure 3-16. Abort Screen

Move the cursor to the preferred option and press **ENTER**.

- **ABORT METHOD**—cancels the method. If necessary, a purge is done to remove solvent from the sample. Then, residual pressure is relieved from the system.
- **CONTINUE METHOD**—resumes the run from the point at which the **STOP** button was pressed.

Runs Stopped Automatically

The Dionex ASE 150 contains built-in diagnostics and sensors that continuously monitor the system. Under certain conditions (for example, if the collection vessel becomes too full or if the hydrocarbon vapor level exceeds the upper limit), the system will automatically stop a run. If this occurs, the Dionex ASE 150 screen will display an error message; the message will remain on-screen until you press a button to clear it or until it is replaced by another error message. For a list of error messages (and corrective action to take), see [Section 4.1](#).

NOTE After a run is stopped (whether manually or automatically), rinse the system before resuming operation. For instructions on how to run a rinse cycle, see [Section 3.5](#).

3.5 Rinsing/Priming the System

During a rinse cycle, approximately 5 mL of solvent is pumped through the system. Run a rinse cycle at the following times:

- After initial setup
- After refilling the solvent reservoir
- After changing solvents (rinse twice to remove all of the previous solvent)
- When the solvent lines contain air
- When acids, bases, salts, or buffers are used as extraction solvents, rinse the system with deionized water at the end of operation.
- After the Dionex ASE 150 has been shut down for more than one day (see [Section 3.9](#))

To run a rinse cycle:

1. Rinse cells are similar to sample cells, but they are blue in color. Check that the rinse cell size is matched to the sample cell size.

Use this rinse cell:	With this sample cell:
Short (P/N 060174)	1 mL, 5 mL, 10 mL, 22 mL, 34 mL
Medium (P/N 060175)	66 mL
Long (P/N 060176)	100 mL

2. Install the rinse cell in the cell holder. Rinse cells are installed in the same way as sample cells; for instructions, see [Section 3.2.5](#).
3. Close the cell door.
4. Open the collection vessel compartment door, toggle the needle switch (see [Figure 3-10](#)) to the **UP** position, and install a new collection vessel (see [Section 3.1.6](#)).
5. Toggle the needle switch to the **DOWN** position.
6. Close the door.
7. Press **RINSE** to begin the rinse cycle. The LED on the **RINSE** button turns on, and will remain lighted while the rinse cycle is in progress.

When the rinse cycle is complete (after about 1 minute), three beeps are emitted and the **RINSE** button LED turns off.

8. Remove the collection vessel used for the rinse cycle.
9. If the oven is hot and you want to start a run right away:
 - a. Put on the thermal gloves (P/N 060372) provided in the Dionex ASE 150 Ship Kit (P/N 066399).
 - b. Remove the rinse cell from the cell holder and place it on the cell rack (P/N 059927) to cool.
 - c. Close the cell door until the next run, to save energy and prevent anyone from accidentally touching a hot surface.

3.6 Editing a Custom Method (Methods 1 through 24)

If none of the Dionex ASE 150 preprogrammed methods described in [Section 2.5](#) is suitable for a particular extraction, edit one of the *custom* methods provided with the Dionex ASE 150.

Before beginning, review the method development guidelines in [Section 3.7](#) and the range of values allowed for each method parameter in [Table 3-1](#). All parameters in the custom methods are initially set to their default values.

Parameter	Function	Value Range
TEMPERATURE	Temperature at which to heat the cell.	Off, 40 to 200 °C (default = 100)
STATIC TIME	The number of minutes to maintain the cell contents (sample and solvent) at the temperature set point.	0 to 99 min (default = 5)
RINSE VOLUME	Amount of solvent to rinse through the sample cell after the static heating step, expressed as a percentage of the cell volume. For example, if the RINSE VOLUME is set to 50%, 5 mL is rinsed through a 10-mL cell, 17 mL is rinsed through a 34-mL cell, and so on.	0 to 150% volume in 5% increments (default = 60)

Table 3-1. Method Parameters

Parameter	Function	Value Range
PURGE TIME	Amount of time the cell is purged with nitrogen. Thermo Fisher Scientific recommends the following settings: <ul style="list-style-type: none"> • 40 to 80 seconds for a 1-mL, 5-mL, 10-mL, or 22-mL cell • 70 to 110 seconds for a 34-mL cell • 160 to 200 seconds for a 66-mL cell • 250 to 290 seconds for a 100-mL cell 	20 to 900 sec (default = 100)
STATIC CYCLE	Number of times the static heating and rinsing steps are performed. When more than one cycle is specified, the rinse volume is divided among the cycles.	1 to 5 (default = 1)
CELL TYPE	Specifies the type of cell used.	SST (stainless steel) (default) Zr (zirconium)

Table 3-1. Method Parameters (Continued)

To edit a custom method (for example, method 1):

1. Press **MENU** to display the **MENU** screen.



Figure 3-17. Menu Screen

2. Move the cursor to **METHOD EDITOR** and press **ENTER**. The **METHOD EDITOR** screen appears (see [Figure 3-18](#)). All parameters do not fit on one screen. To view additional parameters, press the down arrow button.

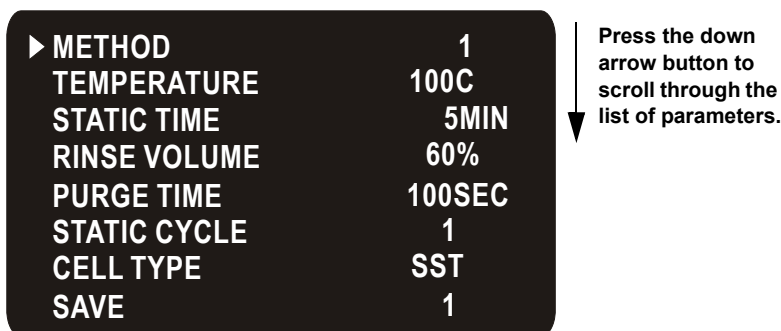

Figure 3-18. Method Editor Screen (All Parameters Shown)

The **METHOD EDITOR** screen displays the parameters for the method last selected on the **SETUP** screen (see [Section C.1.3](#)).

3. To select a different method to edit:
 - a. Press **ENTER** to move the cursor to the method editing field.
 - b. Press an arrow button to step through the method numbers (1 through 24).
 - c. When the desired method number is displayed, press **ENTER**.
4. To edit the method:
 - a. Press an arrow button to move the cursor to the first parameter that you want to change (for example, **TEMPERATURE**).
 - b. Press **ENTER**. The cursor moves to the editing field.

NOTE If you decide not to edit this field, press **MENU** to return the cursor to the left margin of the screen.

- c. Press an arrow button to step through the values allowed for the highlighted value. (Pressing and holding the arrow button steps through the values more rapidly.) When the required value is displayed, press **ENTER**.
- d. If other changes are required, repeat [Step a](#) through [Step c](#).

5. To save the method:
 - a. Press an arrow button to move the cursor to **SAVE** and press **ENTER**.
 - b. To save the modified version of the method to the current method number, press **ENTER**.

NOTE Saving to the current method number will permanently overwrite the previous version of the method.

- c. To save to a different method number, press an arrow button to select the desired number and press **ENTER**.
 - d. Press **MENU** to exit the **METHOD EDITOR** screen and return to the **MENU** screen.

3.7 Developing a New Method

Follow the procedure below to develop a method for a new sample type.

1. Select a solvent (see [Section 3.1.1](#)).
2. Prepare the sample (see [Section 3.1.3](#)).
3. Edit a custom method (see [Section 3.6](#)).
4. Run the new method *three times* (with the same cell and sample, into three separate collection vessels) and analyze the extracts.
5. If target analytes are present in extract 2 or 3, make the adjustments listed below (*one at a time*) to the method. After each adjustment, repeat the method and analyze the extract.
 - a. Raise the temperature. In general, raising the temperature increases the efficiency of the extraction process. However, because compounds can degrade at high temperatures, it is advisable to raise the temperature in small increments (10 to 20 °C). The maximum allowable temperature of the Dionex ASE 150 is 200 °C. If oxidation is a concern, degas the solvent before use.
 - b. Run two static/rinse cycles. Extending the static time enhances diffusion of the analytes into the extraction fluid. Separating the static time into two cycles, instead of using one longer cycle, allows the introduction of fresh

solvent midway through. This helps maintain a favorable solvent/sample equilibrium for samples that are heavily loaded or otherwise difficult to extract.

- c. Increase the rinse volume to allow more solvent to pass through the sample.

NOTE When using 100-mL cells, it may be necessary to balance the number of static cycles and the rinse volume to prevent the collection bottle from being overfilled.

6. If analytes still appear in the extract from the second extract, make the adjustments listed below.
 - a. Run three static/rinse cycles.
 - b. Raise the temperature again.
 - c. Increase static time.
 - d. Select a different solvent or consider additional pretreatment of the sample, such as grinding or hydrolysis.

When target analytes no longer appear in the extract from the second extract, the method is complete for this sample type.

3.8 Performing Routine Maintenance

This section describes routine maintenance procedures that the user can perform. All other Dionex ASE 150 maintenance procedures must be performed by qualified Thermo Fisher Scientific personnel.

3.8.1 Daily Maintenance

- Check the gas supply to the instrument.
- Fill the solvent reservoir, if needed.
- Perform a rinse cycle. After filling the solvent reservoir, always run two rinse cycles (see [Section 3.5](#)) to clear the solvent lines of air.
- Empty the waste bottle, if needed.
- Check for leaks.
- Pull out the drip tray holder below the waste collection vessel compartments (see [Figure 2-1](#)). If the drip tray contains liquid, remove it from the holder, dispose of the liquid, and reinstall the tray.

3.8.2 Periodic Maintenance

NOTE The **EXTRACTION COUNTERS** screen indicates the number of extractions the Dionex ASE 150 has performed (see [Section C.2.5](#)).

- Replace the PEEK seals (P/N 061687, pkg. of 50) inside the cell end caps after approximately 50 extractions (see [Section 5.2](#)).
- Replace the external O-rings (P/N 049457, pkg. of 50 PTFE O-rings; P/N 056325, pkg. of 50 Viton O-rings) in the cell end caps and rinse cells after approximately 50 to 75 extractions (see [Section 5.3](#)). (Viton O-rings are for use in high temperature applications, such as dioxin extraction.)
- Verify that the tips of the three needles that extend from the bottom of the needle mechanism are straight and not damaged or worn. To view the needles, open the collection vessel compartment door and toggle the needle switch to the **UP** position (see [Figure 3-10](#)).

To replace the source needle, see [Section 5.9](#). To replace the vent needles, contact Thermo Fisher Scientific.

- Approximately every 6 months, open the cell door and inspect the upper and lower AutoSeal tips. If a tip is damaged or worn, it should be replaced. Contact Thermo Fisher Scientific for assistance.
- Replace the O-ring, filter, and seals in the static valve every 6 to 12 months (see [Section 5.8](#)).
- Clean the exterior of the system with water and a mild detergent.

3.8.3 Annual Maintenance

- Thermo Fisher Scientific recommends performing preventive maintenance annually. A Dionex ASE 150/ASE 350 Preventive Maintenance Kit (P/N 068954) is available.
- If you frequently extract an acidic or basic sample, consider having the solvent lines replaced when the annual maintenance is performed. The solvent lines must be replaced by a qualified Thermo Fisher Scientific representative.

3.9 Shutting Down

Overnight or Longer Shutdowns

- If acids, bases, salts, or buffers are used as extraction solvents, rinse the system with 100% polar organic solvent (for example, acetone or methanol) or distilled water (see [Section 3.5](#)) before turning off the power.
- After extracting with a 100% organic solvent, you may turn off the power immediately. If the shutdown is for more than one night, also turn off the gas supply.

Before Shipping the Dionex ASE 150

1. After extracting with a solvent that contains acids, bases, or other strong additive, rinse the system with either 100% organic solvent or distilled water (see [Section 3.5](#)).
2. Empty the solvent reservoir, reconnect the reservoir to the system, and run one or more rinse cycles to remove solvent from the lines.
3. Turn off the gas supply, disconnect the gas source at the Dionex ASE 150 rear panel, and remove the solvent reservoir.

4 • Troubleshooting

This chapter is a guide to troubleshooting minor problems that may occur while operating the Thermo Scientific Dionex ASE 150 Accelerated Solvent Extractor.

- [Section 4.1](#) describes error messages and how to troubleshoot them.
- The remaining sections in this chapter describe operating problems and how to resolve them.

If you are unable to resolve a problem by following the instructions here, contact Technical Support for Dionex products. In the U.S. and Canada, call 1-800-346-6390. Outside the U.S. and Canada, call the nearest Thermo Fisher Scientific office. Please have this chapter at hand when talking with Technical Support personnel.

4.1 Error Messages

The Dionex ASE 150 can identify several potential operating problems. If one of these problems occurs, an error message is displayed on the screen. The message remains until you press any button to clear it or until another error message appears.

Each error message is identified by a number. This section lists the error messages and explains how to respond if an error occurs. Most problems can be resolved by the user.

Error 001	Oven compression low.
-----------	-----------------------

Cause:	Insufficient nitrogen gas pressure applied to the oven compression system during a run.
---------------	---

Action:	Check the REGULATORS screen (see Section C.2.3). When the oven is compressed, the COMPRESSION field should read 0.90 ± 0.03 MPa (130 ± 5 psi). If the COMPRESSION field is low, check the gas pressure supplied to the Dionex ASE 150. It should be between 0.97 and 1.38 MPa (140 and 200 psi); 1.03 MPa (150 psi) is recommended. If necessary, replace the gas cylinder.
----------------	--

Action:	If the error message reappears, contact Thermo Fisher Scientific for assistance.
----------------	--

Error 002 System pressure low.

Cause: Insufficient nitrogen gas pressure applied to the system.

Action: Check the **REGULATORS** screen (see [Section C.2.3](#)). The **SYSTEM** field should read 0.34 ± 0.02 MPa (50 ± 3 psi). If the **SYSTEM** field is low, check the gas pressure supplied to the Dionex ASE 150. It should be between 0.97 and 1.38 MPa (140 and 200 psi); 1.03 MPa (150 psi) is recommended. If necessary, replace the gas cylinder.

Action: If the error message reappears, contact Thermo Fisher Scientific for assistance.

Error 003 Oven temperature low.

Cause: The heater cable connection to the power supply is loose, or a heater component malfunctioned.

Action: Contact Thermo Fisher Scientific for assistance.

Error 004 Oven temperature high

Cause: The heater cable connection to the power supply is loose, or a heater component malfunctioned.

Action: Contact Thermo Fisher Scientific for assistance.

Error 005 Cell pressure threshold exceeded.

Cause: A blockage in the system.

Action: Run a rinse cycle (see [Section 3.5](#)). If the rinse runs without error, the sample cell may be plugged. Replace the cell filter (see [Section 3.1.4](#)). If the error still appears, clean or replace the cell frit (see [Section 5.2](#)).

Action: If the rinse has the same error, there may be a blockage in the solvent lines. Contact Thermo Fisher Scientific for assistance.

Error 006 Collection bottle full.

Cause: The collection vessel (bottle or vial) is full.

Action: Install a new collection vessel and continue the run. When the run is complete, combine the extracts from both vessels. Reduce the rinse volume in the method before running again.

Cause: Water vapors are condensing on the upper walls of the collection vessel.

Action: Change the solvent from 100% water to 1% MeOH, if possible.

Cause: A label or written information is blocking the area read by the collection vessel sensor.

Action: Make sure the label is positioned correctly (see [Figure 3-9](#)).

Cause Solvent is leaking into the collection vessel.

Action: If solvent leaks into the collection vessel during the static cycle, the static valve seals are worn. Rebuild the static valve (see [Section 5.8](#)).

Action: If the error message reappears, contact Thermo Fisher Scientific for assistance.

Error 007 Collection bottle not detected.

Cause: The collection vessel (bottle or vial) is not installed.

Action: Install the collection vessel (with the cap screwed on) and toggle the needle switch to the **DOWN** position (see [Figure 3-10](#)).

Action: If the error message reappears, contact Thermo Fisher Scientific for assistance.

Error 008 Cell not detected.

Cause: No sample cell or rinse cell is installed, or the sensor failed to detect the cell.

Action: Install the appropriate cell (see [Section 3.2.5](#)). The installation procedure for sample cells and rinse cells is identical.

Action: If the error message reappears, contact Thermo Fisher Scientific for assistance.

Error 009 Pump volume limit exceeded.

Cause: An empty (or incorrectly installed) solvent reservoir.

Action: Refill the solvent reservoir, if necessary. Check that the solvent reservoir is correctly installed (see [Section B.2.6](#)).

Cause: A leak somewhere in the system.

Action: Remove the right-side panel of the Dionex ASE 150 (see [Section 5.4](#)). Inspect the following fittings for leaks (see [Figure 4-1](#)): pump fittings, pump check valves, pressure transducer fittings, pressure relief valve fittings, static valve fittings, and solvent line fittings. Use a 1/4-inch open-end wrench (P/N 049452) to tighten any leaking fittings. **Do not overtighten!**

If tightening does not stop a leak, the tubing and fitting assembly must be replaced. Contact Thermo Fisher Scientific for assistance.

Action: Pull out the drip tray holder below the oven and check the drip tray. If the tray contains liquid, remove it from the holder, dispose of the liquid, and reinstall the tray. Then, remove the collection vessel and waste bottle from the system. Remove the lower trim panel and check for leaks near the oven and the AutoSeal mechanism.

Error 010 Analog-to-digital converter failed.

Cause: Failure of the main PC board (printed circuit board). The board must be replaced.

Action: Contact Thermo Fisher Scientific for assistance.

Error 011 Solvent vapor threshold exceeded.

Cause: A leaking cell.

Action: Check for foreign material on the threads of the cap, the seal surface, and the cell body. If necessary, replace the O-rings and/or seals (see [Section 5.2](#)).

Tighten the cell end caps hand-tight. **Do not use a wrench or other tool.**

Cause: Incomplete purging of solvent from the cell during the purge cycle.

Action: The optimal purge time varies, depending on the sample cell size (see [Table 3-1](#)). If you are running a preprogrammed method, create a custom method with the appropriate purge time. If you are already running a custom method, edit the method to increase the purge time. For instructions on editing a custom method, see [Section 3.6](#).

Cause: A leak somewhere in the system.

Action: Remove the right-side panel of the Dionex ASE 150 (see [Section 5.4](#)). Inspect the following fittings for leaks (see [Figure 4-1](#)): pump fittings, pump check valves, pressure transducer fittings, pressure relief valve fittings, static valve fittings, and solvent line fittings. Use a 1/4-inch open-end wrench (P/N 049452) to tighten any leaking fittings. **Do not overtighten!**

If tightening does not stop a leak, the tubing and fitting assembly must be replaced. Contact Thermo Fisher Scientific for assistance.

Action: Pull out the drip tray holder below the oven and check the drip tray. If the tray contains liquid, remove it from the holder, dispose of the liquid, and reinstall the tray. Then, remove the collection vessel and waste bottle from the system. Remove the lower trim panel and check for leaks near the oven and the AutoSeal mechanism.

Error 012 Clamp plate temperature low.

Cause: The heater cable connection to the power supply is loose, or a heater component malfunctioned.

Action: Contact Thermo Fisher Scientific for assistance.

Error 013 Clamp plate temperature high.

Cause: The heater cable connection to the power supply is loose, or a heater component malfunctioned.

Action: Contact Thermo Fisher Scientific for assistance.

Error 014 Oven unable to reach temperature.

Cause: Incorrect settings of the oven voltage switches on the Dionex ASE 150 rear panel.

Action: Set both oven voltage switches to match the voltage from the power source at the installation site: either **110** (for voltages between 100 and 120 Vac) or **220** (for voltages between 220 and 240 Vac). For details, see [Section B.2.3](#).

Cause: The heater cable connection to the power supply is loose, or a heater component malfunctioned.

Action: Contact Thermo Fisher Scientific for assistance.

Error 015 Unable to rinse.

Cause: The pump could not deliver the specified rinse volume within the allotted time. The cell or lines may be plugged.

Action: Run a rinse cycle (see [Section 3.5](#)). If the rinse runs without error, the sample cell may be plugged. Replace the cell filter (see [Section 3.1.4](#)) and the cell frit (see [Section 5.2](#)).

Action: If the rinse has the same error, there may be a blockage in the solvent lines. Contact Thermo Fisher Scientific for assistance.

Error 016 Unable to fill cell.

Cause: An empty (or incorrectly installed) solvent reservoir.

Action: Refill the solvent reservoir, if necessary. Check that the solvent reservoir is correctly installed (see [Section B.2.6](#)).

Cause: A leaking static valve seal.

Action: Check the collection vessel for liquid. If liquid is present, replace the static valve seals (see [Section 5.8](#)).

Cause: A leaking fitting somewhere in the system.

Action: Remove the right-side panel of the Dionex ASE 150 (see [Section 5.4](#)). Inspect the following fittings for leaks (see [Figure 4-1](#)): pump fittings, pump check valves, pressure transducer fittings, pressure relief valve fittings, static valve fittings, and solvent line fittings. Use a 1/4-inch open-end wrench (P/N 049452) to tighten any leaking fittings. **Do not overtighten!**

If tightening does not stop a leak, the tubing and fitting assembly must be replaced. Contact Thermo Fisher Scientific for assistance.

Cause: A leaking check valve (internally).

Action: Replace both check valve cartridges (see [Section 5.5](#)).

Error 017 Remove cell during oven wait period.

Cause: A sample cell was installed in the cell holder before the temperature set point was reached.

Action: Remove the cell from the cell holder. Never install the cell until the **STATUS** field (on the **STATUS** screen) indicates **OVEN READY** and the LED on the front panel **START** button is flashing. For details, see [Section 3.2.4](#).

Error 018 Oven heater AC line voltage too high.

- Cause:** Incorrect settings of the oven voltage switches on the Dionex ASE 150 rear panel.
- Action:** Set both oven voltage switches to match the voltage from the power source at the installation site: either **110** (for voltages between 100 and 120 Vac) or **220** (for voltages between 220 and 240 Vac). For details, see [Section B.2.3](#).
- Action:** If selecting the correct switch settings does not correct the problem, contact Thermo Fisher Scientific for assistance.

Error 020 Oven heater malfunction.

- Cause:** Incorrect settings of the oven voltage switches on the Dionex ASE 150 rear panel.
- Action:** Set both oven voltage switches to match the voltage from the power source at the installation site: either **110** (for voltages between 100 and 120 Vac) or **220** (for voltages between 220 and 240 Vac). For details, see [Section B.2.3](#).
- Action:** If selecting the correct switch settings does not correct the problem, contact Thermo Fisher Scientific for assistance.

Error 021 Top plate heater AC line voltage too high.

- Cause:** Incorrect settings of the oven voltage switches on the Dionex ASE 150 rear panel.
- Action:** Set both oven voltage switches to match the voltage from the power source at the installation site: either **110** (for voltages between 100 and 120 Vac) or **220** (for voltages between 220 and 240 Vac). For details, see [Section B.2.3](#).
- Action:** If selecting the correct switch settings does not correct the problem, contact Thermo Fisher Scientific for assistance.

Error 023 Top plate heater malfunction.

Cause: Incorrect settings of the oven voltage switches on the Dionex ASE 150 rear panel.

Action: Set both oven voltage switches to match the voltage from the power source at the installation site: either **110** (for voltages between 100 and 120 Vac) or **220** (for voltages between 220 and 240 Vac). For details, see [Section B.2.3](#).

Action: If selecting the correct switch settings does not correct the problem, contact Thermo Fisher Scientific for assistance.

Error 024 Cell size wrong.

Cause: The cell type specified in the method is zirconium, but the cell size specified on the **SETUP** screen is less than 66 mL. (Zirconium cells are available only in 66 mL or 100 mL sizes.)

Action: Select the correct cell size on the **SETUP** screen (see [Section C.1.3](#)) or, if you are using a stainless steel cell and the cell size is correct, change the cell type on the **METHOD** screen (see [Section C.1.4](#)).

4.2 Liquid Leaks

- **Worn-out seal in sample cell end cap**

Replace the seal (see [Section 5.2](#)).

- **Missing or worn-out cell O-rings**

Check the ends of the cell to verify that the O-rings are in place and in good condition. If any O-ring has a hole size of less than 0.5 mm, replace it. If a white PTFE O-ring is discolored, replace it (see [Section 5.3](#)).

O-rings should last for approximately 50 extractions. To view the number of extractions the Dionex ASE 150 has performed, go to the **EXTRACTION COUNTERS** screen (see [Section C.2.5](#)).

- **Leak in solvent flow path**

Remove the right-side panel of the Dionex ASE 150 (see [Section 5.4](#)). Inspect the following fittings for leaks (see [Figure 4-1](#)): pump check valves, pressure

transducer fittings, pressure relief valve fittings, static valve fittings, and solvent line fittings. Use a 1/4-inch open-end wrench (P/N 049452) to tighten any leaking fittings. **Do not overtighten!**

If tightening does not stop a leak, the tubing and fitting assembly must be replaced. Contact Thermo Fisher Scientific for assistance.

If the pump head is leaking, replace the pump seals (see [Section 5.6](#)).

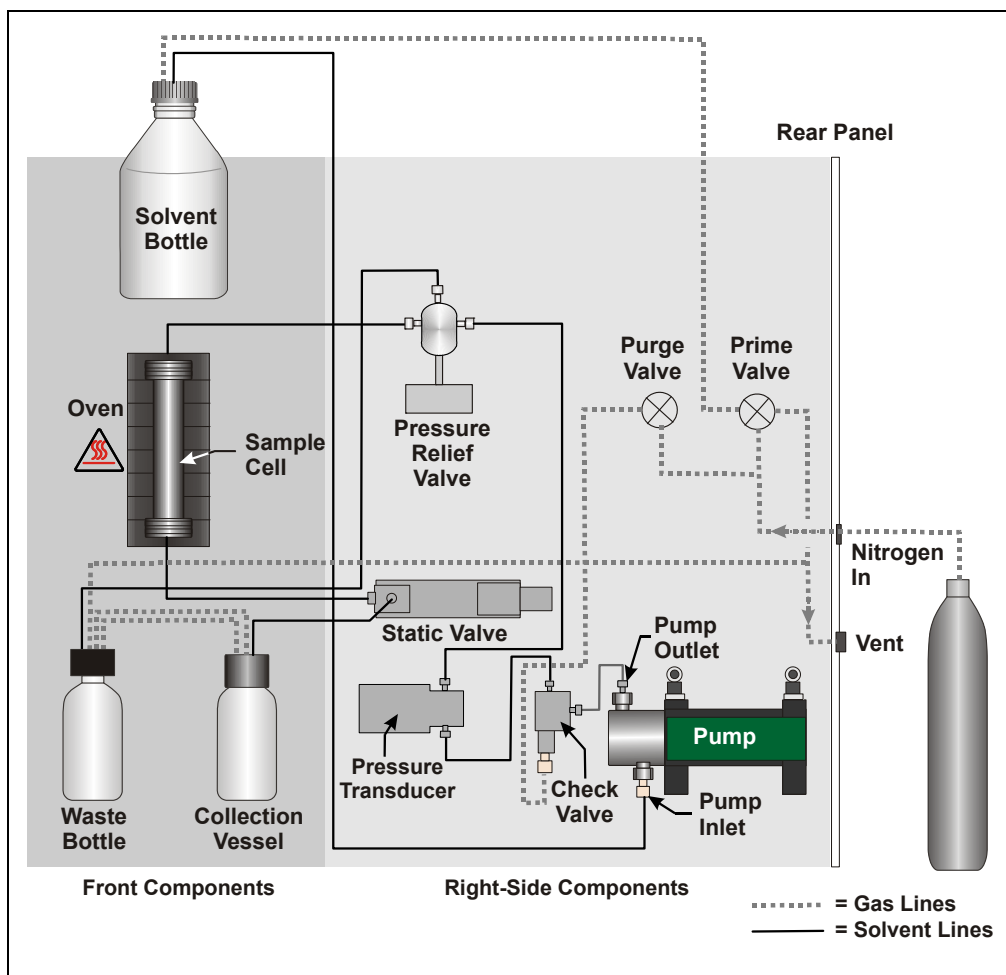

Figure 4-1. Dionex ASE 150 Plumbing Diagram

- **Leaking into waste bottle during static cycle**

If liquid drips into the waste bottle when the cell is under pressure and the static valve is closed, the pressure relief valve is worn and must be replaced (see [Section 5.7](#)).

- **Leaking into collection vessel during static cycle**

If solvent leaks into the collection vessel during the static cycle, the static valve seals are worn and the valve must be rebuilt (see [Section 5.8](#)).

4.3 Gas Leaks

Gas leaks are usually audible. In addition, excessive gas consumption often indicates a gas leak.

If you suspect a leak, check the following locations: gas supply, rear panel, solvent reservoir, and interior connections. Listen for leaks and run your hand over the area to feel for escaping gas.

If you find a loose connection, push the tubing firmly onto its fitting. If the fitting or tubing continues to leak, replace it.

4.4 Stopped System

- **Electrical cables improperly installed**

Remove the right-side panel of the Dionex ASE 150 (see [Section 5.4](#)). Check that all electrical cables are seated properly in their connectors on the main PC board (printed circuit board).

This chapter describes Thermo Scientific Dionex ASE 150 Accelerated Solvent Extractor service and repair procedures that users may perform. All procedures not included here, including electronics-related repair procedures, must be performed by Thermo Fisher Scientific personnel. For assistance, contact Technical Support for Dionex products. In the U.S. and Canada, call 1-800-346-6390. Outside the U.S. and Canada, call the nearest Thermo Fisher Scientific office.

Before replacing any part, refer to the troubleshooting information in [Chapter 4](#) to correctly identify the cause of the problem.

IMPORTANT

Substituting non-Dionex/Thermo Fisher Scientific parts (extraction cells, extraction cell components, valves, etc.) may impair the performance of the Dionex ASE 150, thereby voiding the product warranty. Refer to the warranty statement in the Dionex Terms and Conditions for more information.

5.1 Replacing Tubing and Fittings

Use a 1/4-inch open-end wrench (P/N 049452) to tighten any leaking fittings. **Do not overtighten!**

If tightening a fitting does not stop a leak, the tubing and fitting assembly must be replaced. Contact Thermo Fisher Scientific for assistance.

5.2 Replacing the Cell End Cap Seal

A worn PEEK seal is deeply grooved and will fail to form a tight seal between the cell cap and body during a run, causing leaks.

1. Unscrew the cell end cap from the cell body (see [Figure 5-1](#)).



Wear safety glasses when removing the old snap ring from the cell end cap or installing a new snap ring.



Le port de lunettes de sécurité est requis lors du changement de l'anneau de serrage sur le bouchon des cellules d'extraction.



Tragen Sie eine Schutzbrille, wenn Sie den alten Sicherungsring von der Verschlusskappe der Zelle entfernen oder wenn Sie einen neuen Sicherungsring installieren.



Do not disassemble the cell end cap after each use. This can cause the seal to fail prematurely.

2. Remove the snap ring from the end cap, using the snap ring tool (P/N 056684) provided in the Dionex ASE 150 Ship Kit (P/N 066399).
 - a. Insert the pointed ends of the tool into the two holes in the snap ring (see [Figure 5-1](#)).
 - b. Squeeze the handles of the tool together to reduce the diameter of the ring. At the same time, carefully pull the ring out of the cap.
 - c. Carefully release the handles of the tool and remove the ring from the tool.

NOTE The procedure for stainless steel and zirconium caps is identical. The photos show a stainless steel cap.



Figure 5-1. Removing the Snap Ring

3. Remove the cap insert (see [Figure 5-2](#)).
Remove the PEEK seal from the groove in the bottom of the cap insert.
4. Remove the frit from the bottom of the end cap.
5. Clean the frit by sonicating it in solvent (or replace it).

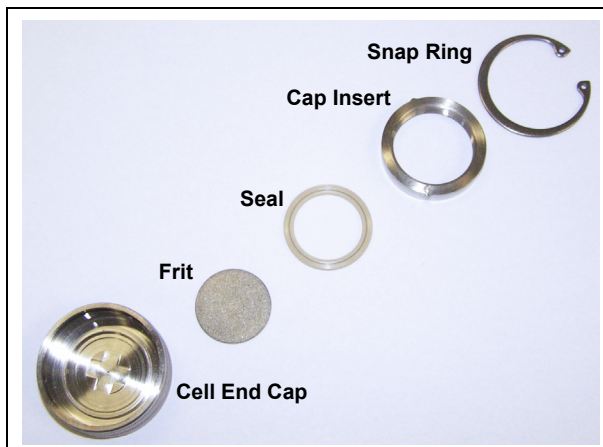

Figure 5-2. Cell End Cap Disassembled

6. Refer to [Figure 5-3](#) and the following steps to reassemble the sample cell.
 - a. Place the new or cleaned frit into the bottom of the end cap.
 - b. Press a new PEEK seal (P/N 061687, pkg. 50) into the bottom of the cap insert.
 - c. Align the pins in the cap insert with the grooves in the end cap and then place the insert, with the seal facing down, into the end cap.
7. With the cap assembly upright on the workbench, install the snap ring:
 - a. Insert the snap ring tool into the holes on the ring.
 - b. Squeeze the tool handles to bring the ends of the ring together.
 - c. Insert the ring into the cap. Using your fingers, push the ring under the lip of the end cap. After verifying that the entire ring is under the lip, release the tension on the tool and remove the tool from the ring.
 - d. Screw the cap back onto the cell body and hand-tighten.

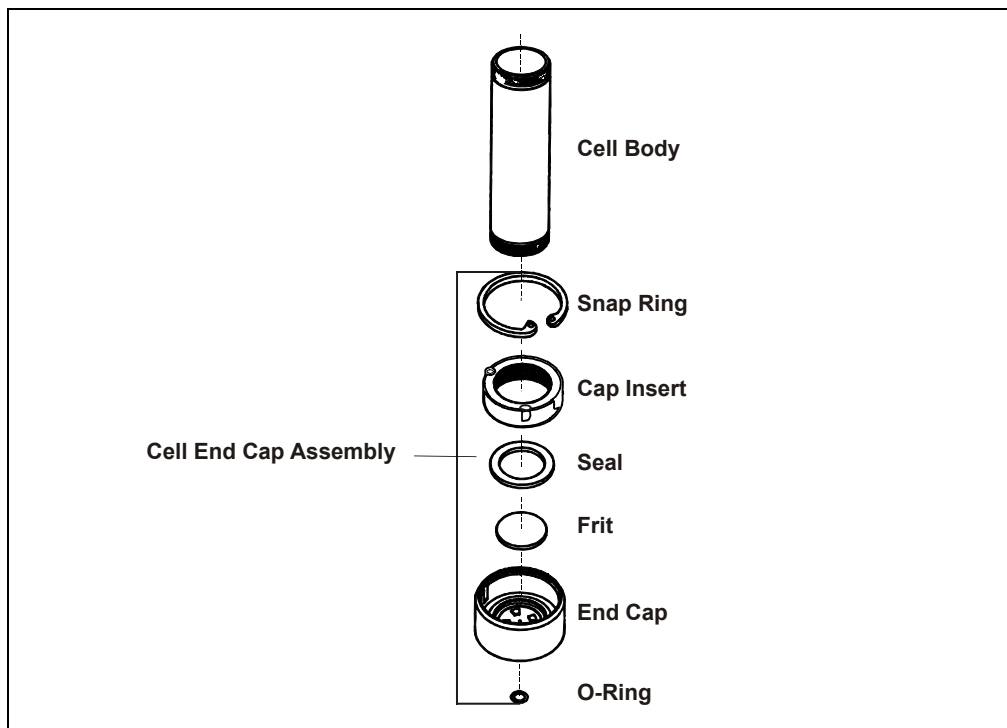

Figure 5-3. Sample Cell Assembly

5.3 Replacing the Cell End Cap O-Ring

IMPORTANT

Be careful not to scratch the interior of the cell end cap when installing or removing the cell O-ring. Scratches on the sealing surface will prevent the O-ring from sealing properly and may result in leaks during operation.

1. Locate the small flathead screwdriver (P/N 046985) and the O-ring insertion tool (P/N/ 049660) in the Dionex ASE 150 Ship Kit (P/N 066399).
2. Insert the tip of the screwdriver into the end cap and *carefully* pick out the O-ring. (This may be easier to do if you first remove the cap from the cell body and place it flat on the workbench.)
3. Place a new O-ring (PTFE, P/N 049457, pkg. of 50; Viton, P/N 056325, pkg. of 50) over the opening in the end of the cell end cap. Press the O-ring into place, using the O-ring insertion tool (see [Figure 5-4](#)).

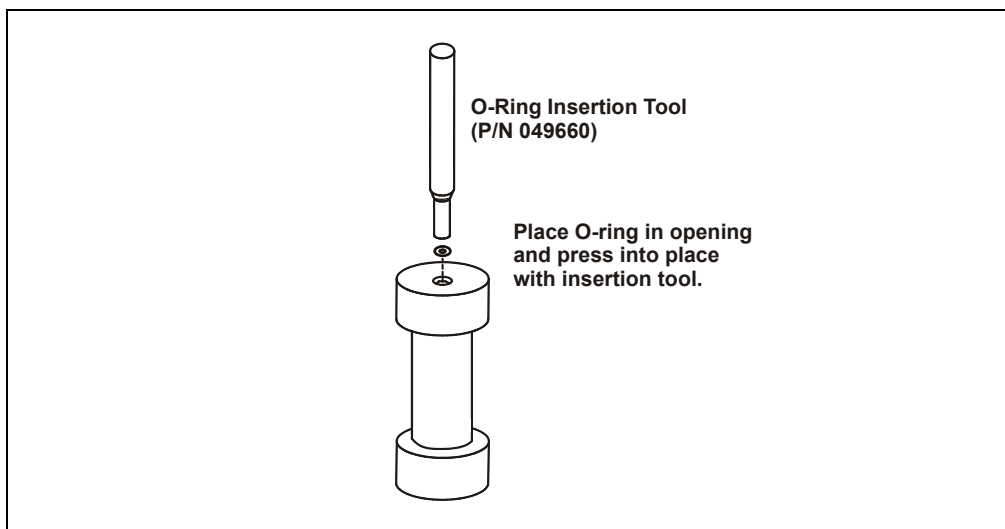

Figure 5-4. Installing the Cell O-Ring

5.4 Removing the Right-Side Panel

Several parts that the user can service are located behind the panel on the right side of the Dionex ASE 150.

Removing the Right-Side Panel

1. Make sure the Dionex ASE 150 power is turned on and the gas supply is on. (This ensures that the AutoSeal mechanism is lowered.)
2. Toggle the needle switch to the **UP** position. If a collection vessel is installed, remove the vessel from the holder and set it aside.
3. Turn off the gas supply. Disconnect the gas source at the Dionex ASE 150 rear panel and let the system vent.
4. Turn off the Dionex ASE 150 main power switch.
5. Unscrew the waste bottle and remove the bottle from the compartment.
6. Close the waste bottle and collection vessel compartment doors.
7. Remove the lower front trim panel of the Dionex ASE 150:
 - a. Slide the drip tray out about halfway.
 - b. Place your fingers in the indentations on both sides of the lower front trim panel and pull the panel toward you to remove it (see [Figure 5-5](#)).



Figure 5-5. Removing the Lower Front Trim Panel

- Using a #2 Phillips screwdriver, remove the two screws on the right side of the inner front panel. One screw is at the top right corner; the other is at the bottom right corner (see [Figure 5-6](#)).

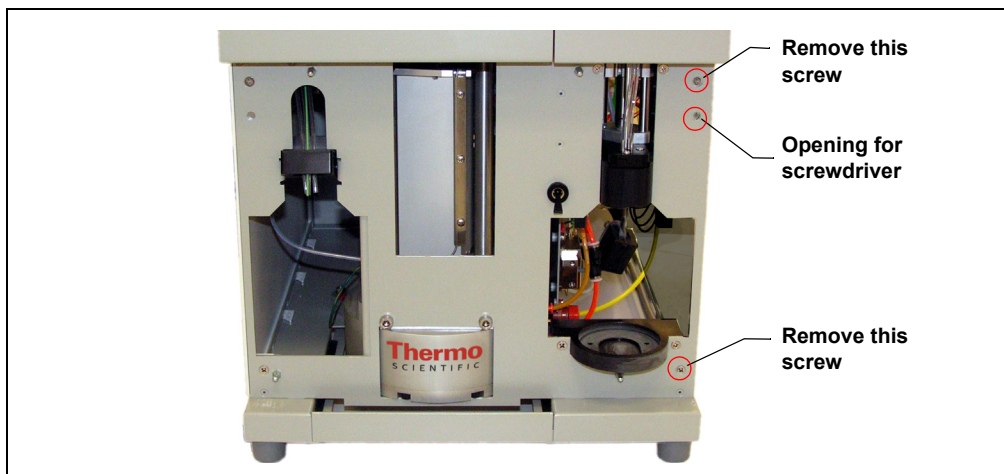

Figure 5-6. Inner Front Panel

- Insert a screwdriver into the opening located beneath the top screw hole (see [Figure 5-6](#)). Push the screwdriver in until the right-side panel slides back about 1/2 inch. **To prevent scratches or other damage to the panel, do not let the panel fall onto the workbench.**
- Remove the right-side panel from the system and set it aside.

Reinstalling the Right-Side Panel

- Hold the panel against the right side of the system. Engage the small tabs on the top and bottom of the panel with the slots in the chassis. Pull the panel forward until it locks into place.
- Replace the two Phillips screws on the inner front panel.
- Slide the drip tray out about halfway.
- Carefully align the lower trim panel with the edges of the instrument, and then gently push the panel into place.
- Reinstall the waste bottle and collection vessel.
- Reconnect the gas source and turn on the gas supply.
- Turn on the Dionex ASE 150 main power switch.

5.5 Replacing Pump Check Valve Cartridges

5.5.1 Before Beginning

Disconnect the solvent reservoir and remove it from the top of the Dionex ASE 150. Run a rinse cycle (see [Section 3.5](#)). This prevents siphoning of solvent when the inlet tubing is disconnected.

5.5.2 Removing the Pump

1. Follow the instructions in [Section 5.4](#) to disconnect the gas source and remove the right-side panel. The Dionex ASE 150 pump is behind the right-side panel in the lower right corner (see [Figure 5-7](#)).

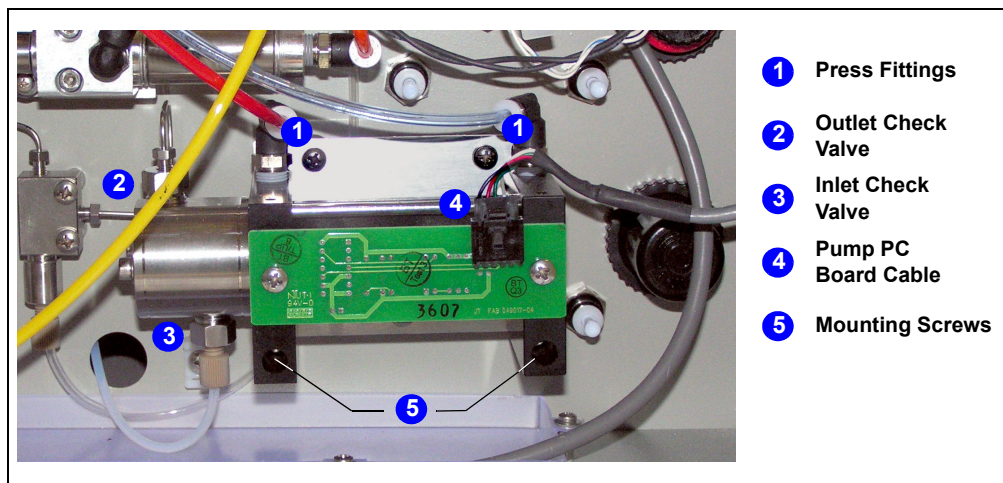

Figure 5-7. Dionex ASE 150 Pump (Behind Right-Side Panel)

2. Disconnect the red tubing and the transparent blue tubing from the two black elbow press fittings (1) on top of the pump.
To disconnect a press fitting, use your fingers (or a small open-end wrench) to press the ring on the fitting *in*, while at the same time pulling the tubing *out*.
3. Use a 1/4-inch open-end wrench to disconnect the stainless steel fitting from the outlet check valve (2).
4. By hand, disconnect the PEEK fitting from the inlet check valve (3).

5. Disconnect the gray cable from the pump PC board (4).
6. Use a 3-mm hex screwdriver (P/N 060154) to remove the screws in the left and right end plates (5) on the pump. These screws secure the pump to the component panel.

5.5.3 Removing the Check Valves and Cartridges

1. Use a 1/2-inch open-end wrench to loosen the *inlet* check valve housing. Remove the housing and then remove the check valve cartridge from the housing (see [Figure 5-8](#)).

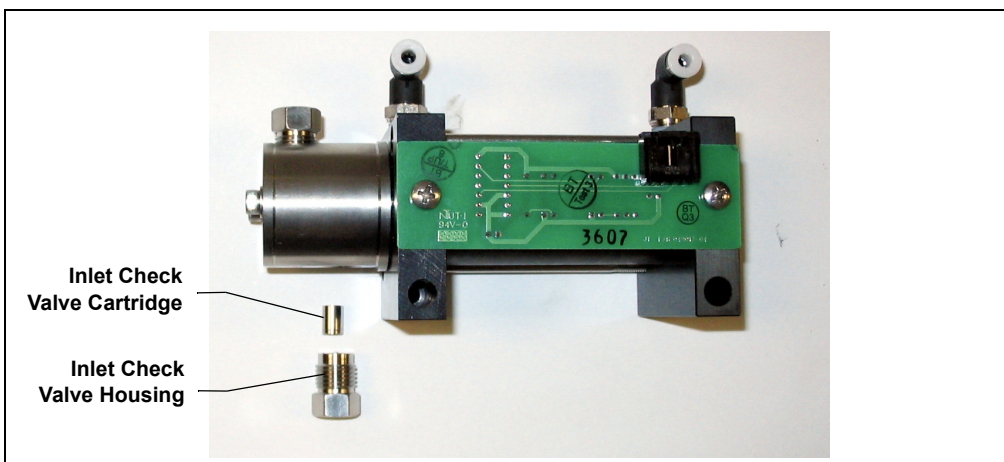

Figure 5-8. Disassembled Dionex ASE 150 Pump Inlet Check Valve

2. Turn the pump over, so that the outlet check valve is facing down.
3. Use a 1/2-inch open-end wrench to loosen the *outlet* check valve housing. Remove the housing and then remove the check valve cartridge from the housing.

NOTE The housing for the *inlet* check valve assembly has a 1/4-28 port. The housing for the *outlet* check valve assembly has a 10-32 port (see [Figure 5-9](#)).

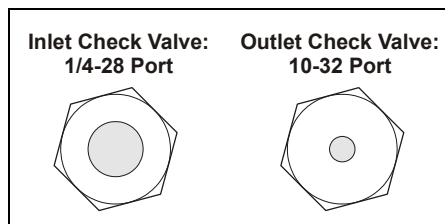

Figure 5-9. Check Valve Housings

5.5.4 Installing New Check Valve Cartridges

1. Install the new inlet cartridge (P/N 047755) in the inlet check valve housing so that the double-hole end of the cartridge is visible (see [Figure 5-10](#)).
2. Install the new outlet cartridge (P/N 057346) in the outlet check valve housing so that the arrow on the cartridge points down.

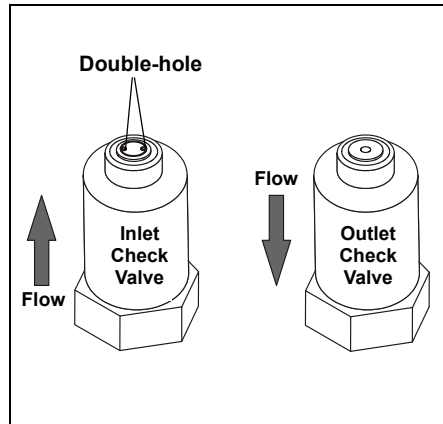

Figure 5-10. Check Valve Assemblies

5.5.5 Reinstalling the Check Valves

1. Install the inlet check valve assembly on the bottom of the pump head.
2. Install the outlet check valve assembly on the top of the pump head.
3. Tighten the check valves fingertight, and then use a wrench to tighten an additional one-quarter to one-third turn.



Overtightening may damage the pump head and check valve housing and crush the check valve seats.

5.5.6 Cleaning the Check Valves

Clean the check valves if new check valves are unavailable.

1. Place the check valve housings and cartridges in a beaker with methanol. Sonicate or agitate for several minutes.
2. Rinse each check valve housing and cartridge thoroughly with filtered, deionized water.
3. Reinstall the check valves on the pump.

5.5.7 Reinstalling the Pump

1. Reinstall the pump on the component panel.
2. Reconnect the red gas line to the left press fitting on top of the pump. Reconnect the transparent blue gas line to the right press fitting.
3. Reconnect the solvent lines to the inlet and outlet check valve housings.
4. Reconnect the cable to the pump PC board.

5.5.8 Completing the Procedure

1. Follow the instructions on [page 75](#) to reinstall the right-side panel.
2. Reconnect the gas source at the Dionex ASE 150 rear panel and turn on the gas supply.
3. Turn on the Dionex ASE 150 main power switch.
4. Rinse the system (see [Section 3.5](#)) and check that the pump flow is normal.

5.6 Replacing Pump Seals

5.6.1 Before Beginning

Disconnect the solvent reservoir and remove it from the top of the Dionex ASE 150. Run a rinse cycle (see [Section 3.5](#)). This prevents siphoning of solvent when the inlet tubing is disconnected.

5.6.2 Removing the Pump

Follow the instructions in [“Removing the Pump” on page 76](#).

5.6.3 Replacing the Piston High-Pressure Seal

1. Use a 3-mm hex driver (P/N 060154) or wrench to loosen and remove the two screws securing the pump head to the body.
2. Slide the pump head straight off the pump (see [Figure 5-11](#)).



Lateral motion while disengaging the pump head from the pump may break the piston.

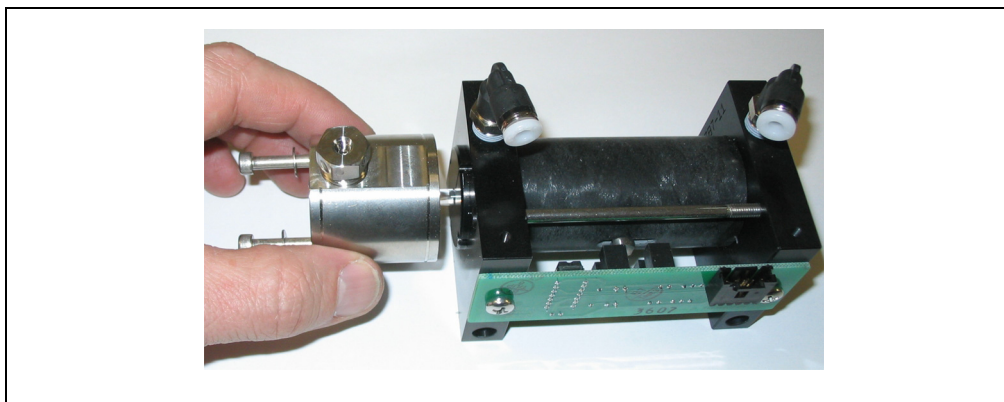

Figure 5-11. Removing the Pump Head

- Turn the pump head over so that the open end is down. The tan piston guide (see [Figure 5-12](#)) should drop out of the head; if it does not, gently tap the head on the workbench to dislodge the guide. Save the piston guide (it will be reinstalled in [Step 7](#)).

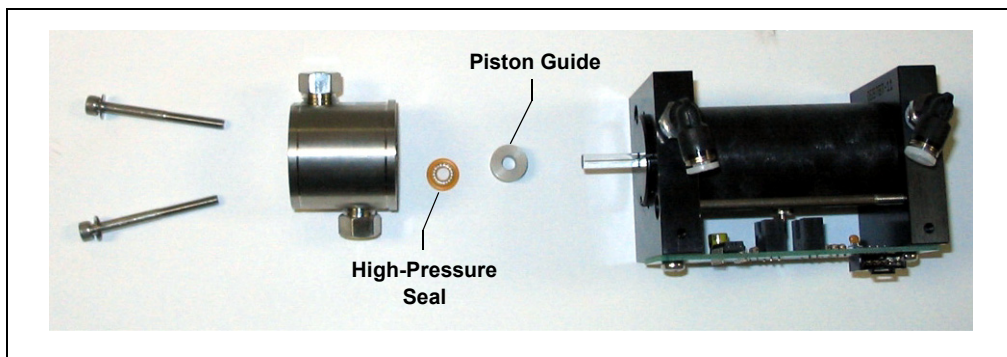

Figure 5-12. Replacing the Dionex ASE 150 Piston High-Pressure Seal

- If tapping the head on the bench does not remove the piston guide, use the wooden end of a cotton-tipped swab to pry the guide out of the pump head. Discard the used piston guide.
- To remove the orange high-pressure seal from the pump head, insert the wooden end of a cotton-tipped swab and pry out the seal. Discard the seal.

IMPORTANT

Do not use a sharp tool (such as tweezers) to remove or install the high-pressure piston seal. This will scratch the seal and the inside of the pump housing; these scratches will prevent a proper seal and allow leakage.

- Hold the new high-pressure seal (P/N 066162), with the smaller diameter (ringed) side of the seal facing down, and drop it into the pump head cavity.
- If the piston guide was easily removed from the pump head ([Step 3](#)), place the original piston guide on top of the high-pressure seal and firmly press it into place. This also seats the high-pressure seal in the pump head.

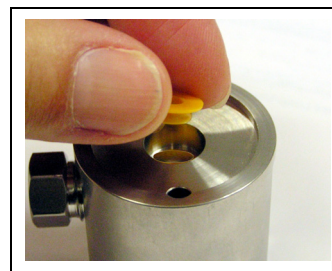

If you had to pry the piston guide out of the pump head ([Step 4](#)), install a new piston guide (P/N 066109) as described above. The original piston guide may have been scratched during removal, so do not use it again. A scratched guide will not seal properly.

8. Reinstall the pump head onto the pump

5.6.4 Replacing the Piston Air Seal

1. Remove the PC board from the side of the pump (see [Figure 5-13](#), view A).
2. Loosen the two bolts that hold the two end plates together (see [Figure 5-13](#), view B).

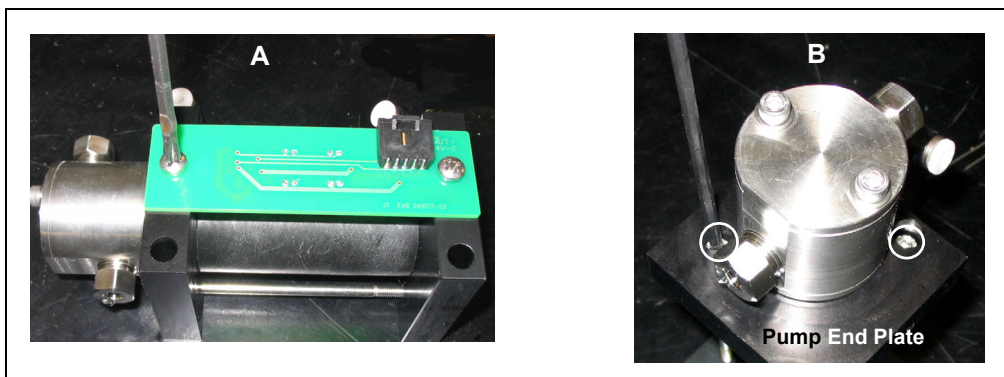

Figure 5-13. Removing the Pump PC Board and End Plate Bolts

3. Remove the right end plate from the pump cylinder (see [Figure 5-14](#)).

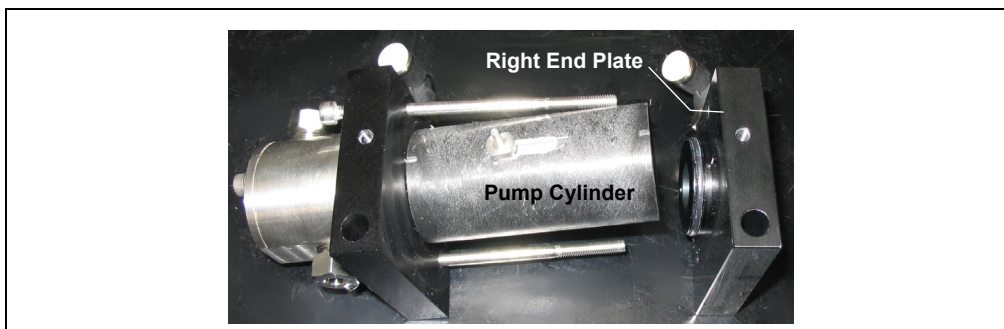

Figure 5-14. Removing the Pump Right End Plate

4. Remove the left end plate from the cylinder, exposing the piston (see [Figure 5-15](#)).

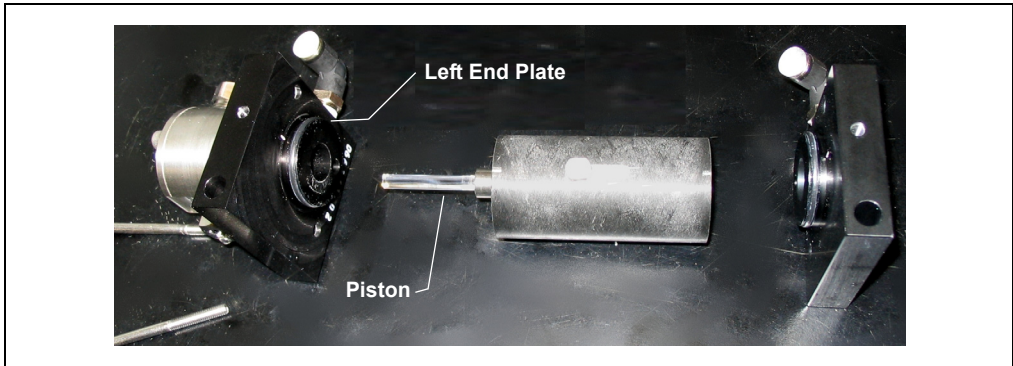

Figure 5-15. Removing the Pump Left End Plate

5. To remove the piston air seal from the left end plate (see [Figure 5-16](#)), insert the wooden end of a cotton-tipped swab and pry out the seal. Discard the seal.

IMPORTANT

Do not use a sharp tool (such as tweezers) to remove or install the piston air seal. This will scratch the seal and the inside of the pump housing; these scratches will prevent a proper seal and allow leakage.

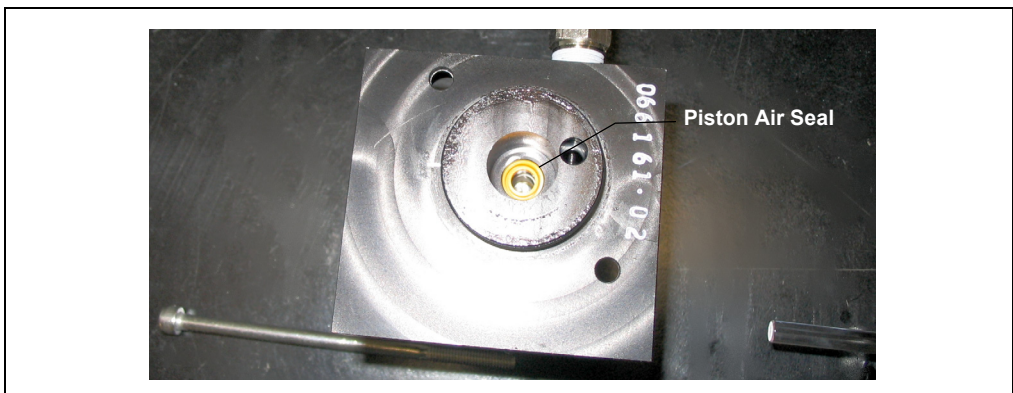

Figure 5-16. Removing the Piston Air Seal

6. Insert the new piston air seal (P/N 066163), with the closed end facing down, into the end plate. Gently press the seal into place with a cotton-tipped swab (or other tool with a soft tip).

7. Gently insert the piston into the new seal in the left end plate. Push the pump cylinder over the O-ring on the left end plate. Push the pump cylinder over the O-ring on the right end plate.
8. Loosely secure the end plates together with the two bolts removed previously.
9. Place the assembled pump on a flat surface. Make sure all four alignment marks on the pump cylinder and end plates are aligned (see [Figure 5-17](#)). Press down on the end plates to square them with each other. The pump should sit evenly on the flat surface without rocking.

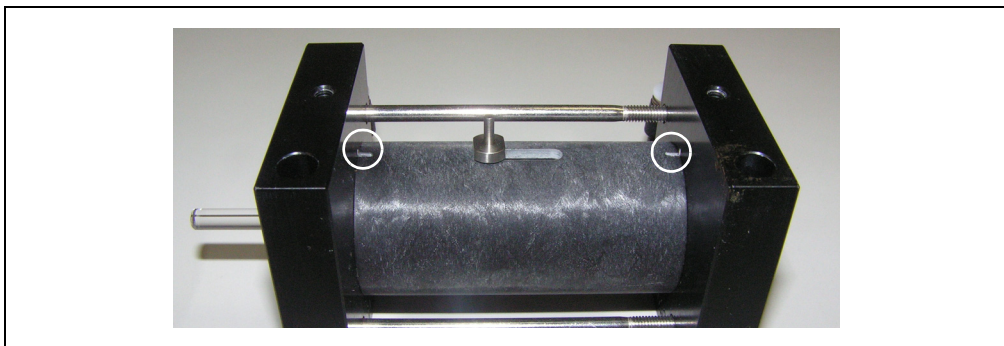

Figure 5-17. Alignment Marks on Pump Cylinder and End Plates

10. Tighten the two bolts evenly.
11. Reattach the PC board to the side of the pump.

5.6.5 Reinstalling the Pump and Completing the Procedure

1. Reinstall the pump on the component panel.
2. Reconnect the red gas line to the left press fitting on top of the pump. Reconnect the transparent blue gas line to the right press fitting.
3. Connect the solvent lines to the inlet and outlet check valve housings.
4. Reconnect the cable to the PC board.
5. Follow the instructions on [page 75](#) to reinstall the right-side panel.
6. Reconnect the gas source at the Dionex ASE 150 rear panel and turn on the gas supply.

7. Turn on the Dionex ASE 150 main power switch.
8. Reset the **PUMP STROKE** counter on the **EXTRACTION COUNTERS** screen (see [Section C.2.5](#)).

5.7 Replacing the Pressure Relief Valve

1. Follow the instructions in [Section 5.4](#) to disconnect the gas source and remove the right-side panel.
2. The pressure relief valve is installed in the upper left corner of the component panel (see [Figure 5-18](#), ①). Disconnect the yellow gas tubing (②) from the elbow press fitting on the valve.

To disconnect a press fitting, use your fingers (or a small open-end wrench) to press the ring on the fitting *in*, while at the same time pulling the tubing *out*.

3. Use a 1/4-inch open-end wrench to disconnect the stainless steel line (③) from the right side of the valve. (This tubing connects to the pump transducer.)
4. Use the wrench to disconnect the Hastelloy[®] line (④) from the left side of the valve. (This tubing connects to the upper AutoSeal tip.)

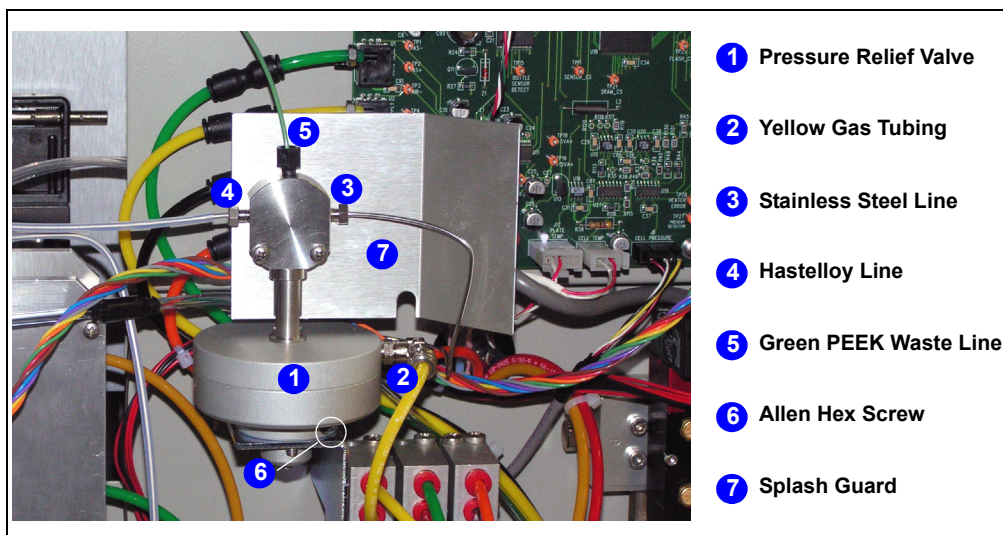

Figure 5-18. Connections to the Pressure Relief Valve

5. Use the wrench to disconnect the green PEEK waste line (5) from the top of the valve.
6. Use a 9/64-inch Allen wrench to loosen the hex screw on the clamp ring below the valve base (6).
7. Lift the old valve off the valve base.
8. Remove the splash guard (7) on the old valve by removing the two Phillips screws on the valve.
9. Attach the splash guard to the new pressure relief valve (P/N 048889).
10. Lower the new pressure relief valve onto the valve base. Tighten the Allen hex screw on the clamp ring.
11. Reconnect all of the lines.
12. Follow the instructions on [page 75](#) to reinstall the right-side panel.
13. Turn on the Dionex ASE 150 main power switch.
14. Reconnect the gas source at the Dionex ASE 150 rear panel and turn on the gas supply.

5.8 Rebuilding the Static Valve

Leaking from the source needle into the collection vessel during the static cycle indicates that the static valve is worn and must be rebuilt. The rebuild procedure consists of replacing a few parts (an O-ring, a filter, and two seals) and then cleaning the inside of the valve body.

Before proceeding, check that the following kits are on hand. The kits contain the replacement parts and special tools required to rebuild the valve.

- Order a Static Valve Repair Kit (P/N 068115) each time the valve requires rebuilding.

Part Number	Item	Quantity
065254	<i>Dionex ASE 150/ASE 350 Static Valve Repair Kit Instructions</i>	1
066165	High-pressure flangeless seal	2
067326	Perlast [®] O-ring	1
067327	Zirconium filter	1

Table 5-1. Static Valve Repair Kit Contents

- Order a Static Valve Tool Kit (P/N 068116) only the first time the valve requires rebuilding. [Figure 5-19](#) illustrates each tool.

Part Number	Static Valve Tool	Quantity
049293	Tubing, orange (extension tubing)	60.96 cm (24 in)
057395	Union (for extension tubing)	1
067394	Piston-side seal insertion tool	1
067395	Inlet-side seal insertion tool	1
068117	Alignment tool	1
068118	Spacer tool	1
068119	Push screw tool	1
068245	Seal removal tool	1

Table 5-2. Static Valve Tool Kit Contents



Figure 5-19. Static Valve Tools

Additional Required Items

- #2 Phillips screwdriver
- 1/4-inch open-end wrench (P/N 049452); provided in the ASE 150 Ship Kit (P/N 066399)
- 2.5-mm hex wrench
- 5/8-in open-end wrench or socket
- Large flathead screwdriver
- Cotton-tipped swabs (or other tool with a soft tip)
- Isopropyl alcohol (IPA) or acetone

5.8.1 Removing the Static Valve from the System

1. Turn off the Dionex ASE 150 main power switch.
2. Follow the instructions in [Section 5.4](#) to disconnect the gas source and remove the right-side panel.

The static valve is installed on the lower left side of the component panel, below the pressure relief valve (see [Figure 5-20](#)).

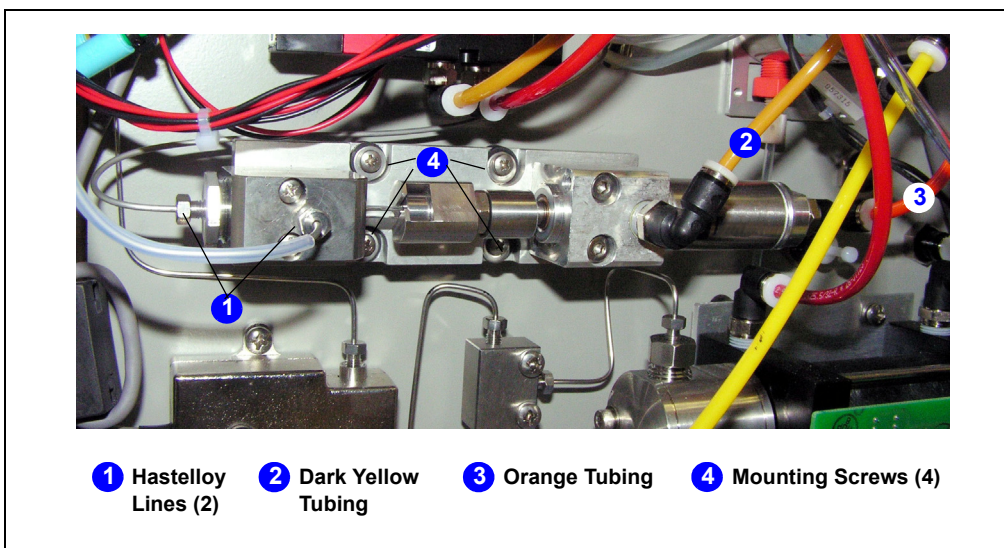

Figure 5-20. Removing the Static Valve

3. Using a 1/4-inch open-end wrench, disconnect the two Hastelloy fluid lines from the valve ①.
4. Disconnect the dark yellow ② and orange ③ tubing from the press fittings on the valve.

To disconnect a press fitting, use your fingers (or a small open-end wrench) to press the ring on the fitting *in*, while at the same time pulling the tubing *out*.

5. Using a 2.5-mm hex wrench, remove the four screws ④ that secure the static valve to the Dionex ASE 150.

- Remove the static valve assembly from the system and place it on the workbench (see [Figure 5-21](#)).

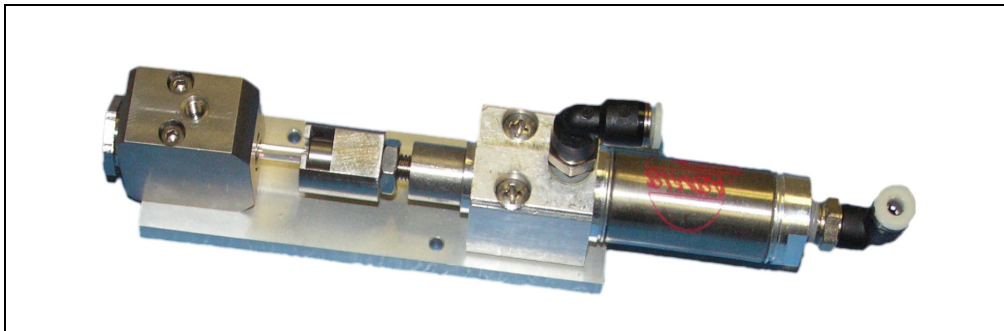
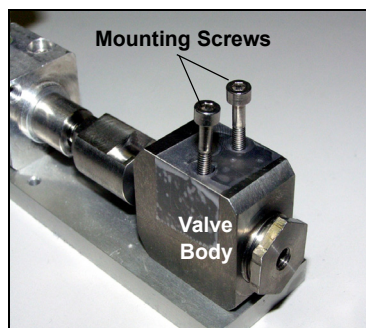
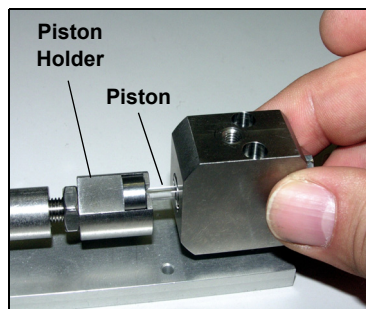

Figure 5-21. Static Valve

- Using a 2.5-mm hex wrench, remove the two mounting screws that secure the valve body to the base plate of the valve assembly.



- Follow these steps to remove the piston from the static valve:
 - Locate the slot in the piston holder. If necessary, rotate the piston holder so that the opening in the slot faces up.
 - Guide the piston out of the piston holder by lifting the valve body straight up. This removes both the piston and the valve body. **Do not drop the piston.**



IMPORTANT

Dropping the piston may cause scratches or breakage. If the piston is damaged, it cannot be used again and must be replaced.

- c. Pull the piston out of the valve body and place it in a secure location.

5.8.2 Disassembling the Static Valve Body

1. Remove the nut installed in each side of the valve body:

- a. Using a 5/8-in open-end wrench or socket, remove the nut on the inlet side of the valve body.

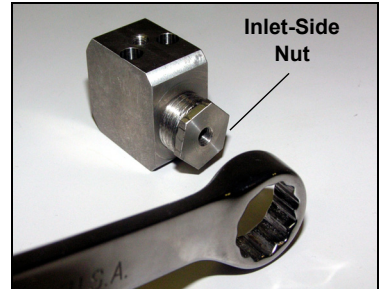

- b. Remove the seal backup ring and the filter from the inlet side (they may fall out on their own). **Save the seal backup ring.** You can discard the filter.

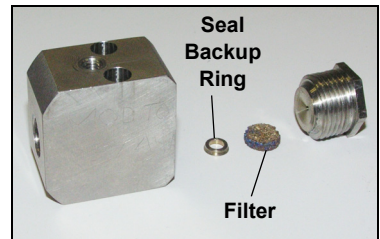

- c. Using a large flathead screwdriver, remove the nut on the piston side of the valve body.

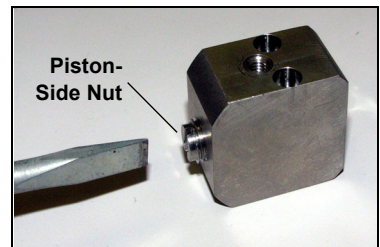

IMPORTANT

Do not use a sharp object inside the valve body. Any scratches on the valve body will prevent a proper seal and allow leakage.

2. Insert the flat end of the seal removal tool (P/N 068245) into the piston side of the valve body and push the inlet-side seal out of the valve body.
3. Pull the seal removal tool out of the valve body.

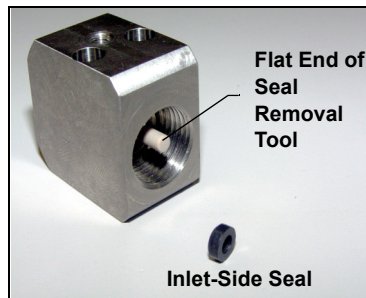

4. Insert the flat end of the seal removal tool into the inlet side of the valve body and push the seal out of the piston side of the valve body.



5. Insert the pointed end of the seal removal tool into the valve body. Slide the tool between the valve body and O-ring and pull the O-ring out of the valve body.



6. Using a cotton-tipped swab (or other tool with a soft tip), thoroughly clean the inside of the valve body. If necessary, moisten the area with IPA (isopropyl alcohol) or acetone to remove all debris, sediment, and precipitates.

IMPORTANT

Do not use a sharp object to clean the inside of the valve body. Any scratches on the valve body will prevent a proper seal and cause leakage.

5.8.3 Installing the New Seals

1. Push the piston through the piston-side seal insertion tool (P/N 067394).
2. Wet a new seal (P/N 066165) with IPA (isopropyl alcohol) for lubrication.
3. Note that one side of the seal is flat, while the other side contains an O-ring. Orient the O-ring side of the seal so that it faces away from the tool, and then slide the seal onto the piston.
4. Place the valve body, with the piston side (small opening) facing up, on the workbench.
5. Rest your thumbs on the back of the tool and press down firmly (with equal pressure) on the left and right sides of the tool. You should hear a snap as the new seal is seated in the valve body. Remove the piston and the tool from the valve body.

NOTE: If there is no audible snap, check the seal for damage. An undamaged seal will lie completely flat in the valve body, with no visible edges. If the seal is damaged, remove it from the valve body. Contact Thermo Fisher Scientific to order a replacement seal.

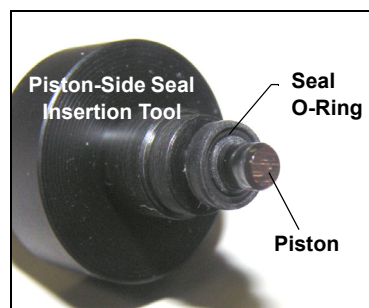
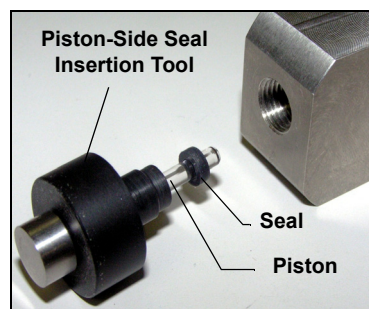

IMPORTANT

Do not use a sharp object inside the valve body. Any scratches on the valve body will prevent a proper seal and allow leakage.

6. Place a new seal (P/N 066165), with the O-ring side facing up, into the inlet gland (large opening) of the valve body.

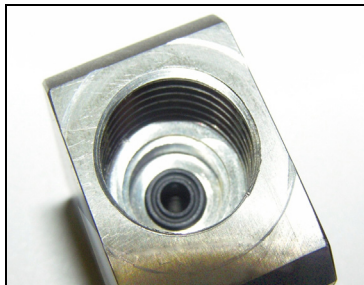

7. Use the inlet-side seal insertion tool (P/N 067395) to press the new seal into place.



5.8.4 Reassembling the Static Valve

1. Place the seal backup ring, with the flat side facing up, on top of the seal in the inlet gland. When correctly installed, the backup ring completely covers the mounting surface.

NOTE: The seal backup ring was removed from the valve body in [Step 1](#) on [page 91](#).



2. Place the new filter (P/N 067327) on top of the backup ring. Check that the filter is seated, lies flat, and is centered in the inlet gland.



3. Insert the new O-ring (P/N 067326) into the cavity and press it all the way into the cavity, using the flat end of the seal removal tool.

**IMPORTANT**

When completing the valve reassembly, make sure the valve body remains upright to avoid dislodging the backup ring, filter, and O-ring.

4. Reinstall the nut on the inlet side of the valve body and tighten with a 5/8-in open-end wrench or socket. Use another open-end wrench to hold the valve body in place while tightening the nut.



5. Reinstall the nut on the piston side of the valve body and tighten with a flathead screwdriver.



6. Insert the piston into the valve body.



7. Slide the piston ferrule onto the piston holder at the end of the cylinder.

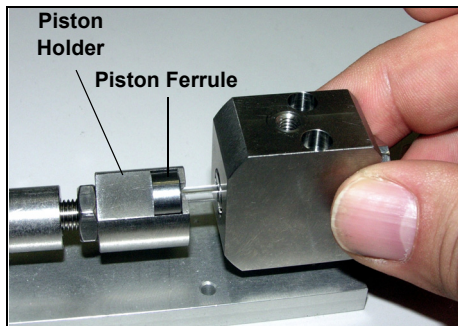

8. Replace the two mounting screws in the valve body and screw them loosely into the valve body to secure the body to the base plate. **Do not fully tighten the screws yet.**

9. Slide the spacer tool (P/N 068118) between the valve body and the piston ferrule.

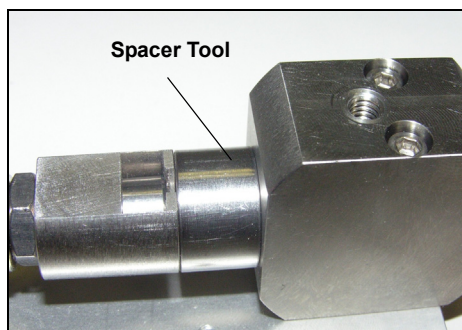

10. Screw the push screw tool (P/N 068119) into the opening in the end of the alignment tool (P/N 068117).

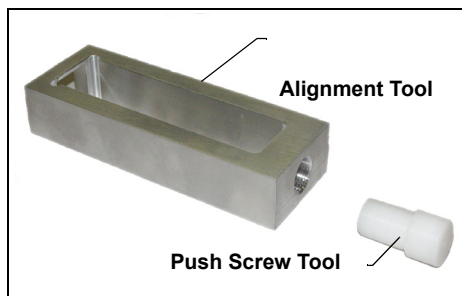

11. Place the alignment tool (P/N 068117) on top of the static valve.

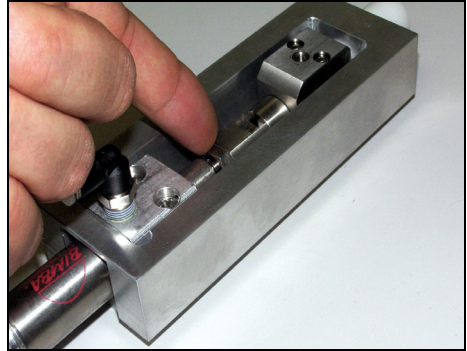

12. Reconnect the gas source and turn on the gas supply. Check the dark yellow and orange lines to see which one is dispensing gas; connect this line to the press fitting on the back of the valve cylinder.

If the gas line is too short to reach the valve, use the union (P/N 057395) to connect the piece of orange extension tubing (P/N 049293) to the end of the line.

13. The gas pressure will extend the cylinder shaft fully and hold the spacer tool firmly in place between the valve body and the piston holder.

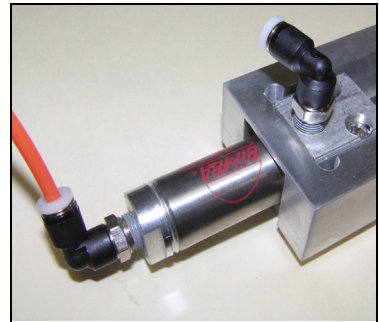

14. Start turning the push screw tool clockwise until the opposite side of the alignment tool touches the back of the cylinder. With the cylinder shaft still extended, fully tighten the valve body mounting screws that you partially tightened in [Step 8](#).

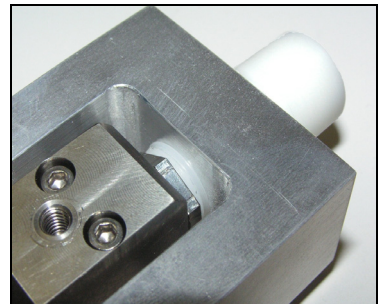

15. Turn the push screw tool counterclockwise. Remove the alignment tool from the valve.

16. Turn off the gas supply and disconnect the gas line from the valve. Remove the orange extension tubing, if used.
17. Slide the cylinder shaft toward the cylinder. Remove the spacer tool from between the valve body and the piston ferrule.

5.8.5 Reinstalling the Static Valve

1. Reattach the static valve to the Dionex ASE 150, using the four screws removed in [Section 5.8.1](#). Use a 2.5-mm hex wrench to tighten the screws. Tighten until the screw head touches the rubber bumper on the mounting bracket and then turn an additional one-half turn. **Do not overtighten!**
2. Reconnect all fluid and gas connections to the static valve. (Refer to the label on the inside of the right-side panel.)
3. Reconnect the gas source and turn on the gas supply.
4. Turn on the Dionex ASE 150 main power switch.
5. Follow the steps below to test the system for leaks:
 - a. Install one of the following in the cell holder: a “blank” sample cell of any size filled with Ottawa sand (Fisher S23-3) *or* an empty sample cell with a volume of less than 34 mL. (A “blank” cell contains no sample.)
 - b. Install a 250-mL collection bottle in the collection bottle holder and toggle the needle switch to the **DOWN** position.
 - c. Check that the waste bottle is installed.
 - d. Press **MENU** to display the **MENU** screen.
 - e. Move the cursor to **METHOD EDITOR** and press **ENTER** to display the **METHOD EDITOR** screen.
 - f. Select a custom method for editing. Select the following values for the method:

TEMPERATURE	Off
STATIC TIME	1
RINSE VOLUME	0%

PURGE TIME	60 s (If the test solvent is water, set the purge time to 120 s.)
STATIC CYCLE	1
CELL TYPE	SST

- g. When you finish editing, save the method and then press **MENU** to return to the **MENU** screen.
- h. Move the cursor to **SETUP** and press **ENTER** to display the **SETUP** screen.
- i. Press **ENTER** to move the cursor to the method editing field. Press an arrow button to step through the existing methods. When the method created for the leak test is displayed, press **ENTER**.
- j. Press **START** twice to begin the run.
- k. During the static cycle, check the 5/8-inch nut connection on the inlet side of the valve body for leaks. If there is a leak, use a 5/8-inch open-end wrench or socket to tighten the connection. Use another wrench to hold the valve body in place while tightening the nut.

During the static cycle, also check the tip of the source needle (the needle with the smaller diameter, near the front of the needle assembly) in the collection vessel. If liquid drips from the source needle into the collection vessel during the static cycle (when the static valve should be closed), it indicates that the valve was not rebuilt correctly. Press **STOP** to stop the run (or wait for the method to finish) and then reassemble the valve correctly.

- l. When the system passes the leak test, remove the waste bottle and collection bottle and go on to [Step 6](#).
6. Follow the instructions on [page 75](#) to reinstall the right-side panel, waste bottle, and collection vessel.
7. Reset the **EXTRACTION** counter on the **EXTRACTION COUNTERS** screen (see [Section C.2.5](#)).

5.9 Replacing the Source Needle

1. Toggle the needle switch to the **DOWN** position.
2. Follow the instructions in [Section 5.4](#) to disconnect the gas source and remove the right-side panel.
3. Use a 2.5-mm hex wrench to remove the two screws on the top of the needle block (see [Figure 5-22](#)).

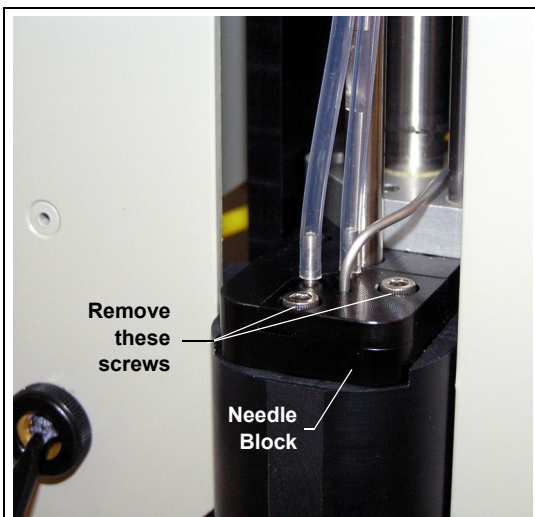

Figure 5-22. Removing the Needle Block Screws

4. Slide the cover of the needle block to the front and right, away from the needle (see [Figure 5-23](#)). Remove the cover.

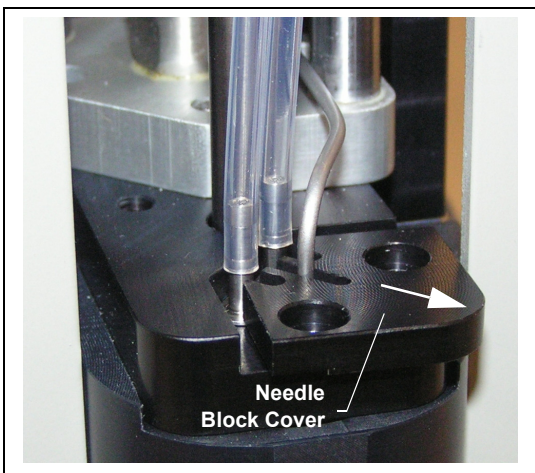

Figure 5-23. Removing the Needle Block Cover

5. Lift up the source needle to remove it from the needle block (see [Figure 5-24](#)) and then pull the needle through the rear of the needle assembly.

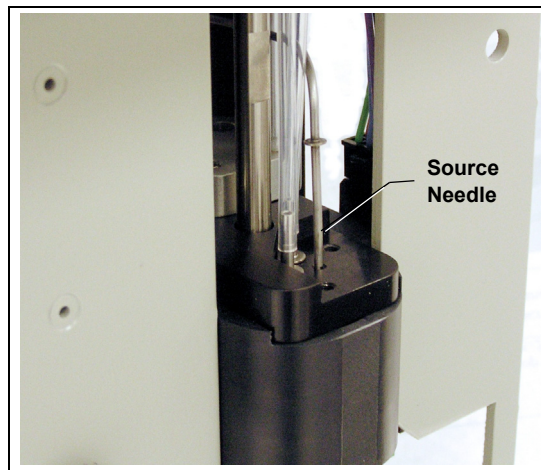

Figure 5-24. Removing the Source Needle from the Needle Block

6. Use a 1/4-inch open-end wrench to disconnect the fitting on the side of the static valve (see [Figure 5-25](#)).

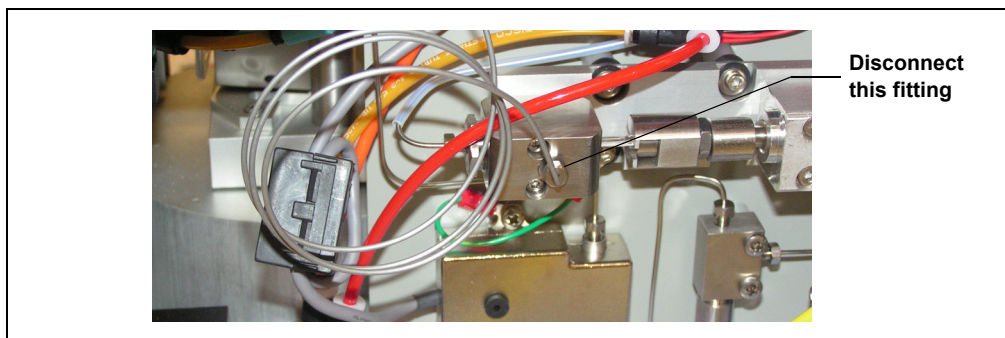

Figure 5-25. Disconnecting the Source Needle Fitting from the Static Valve

7. Remove the source needle and tubing from the Dionex ASE 150.

- From behind the needle assembly, route the new source needle and tubing (P/N 068961) through the two posts on the needle assembly and then to the front of the needle assembly (see [Figure 5-26](#)).

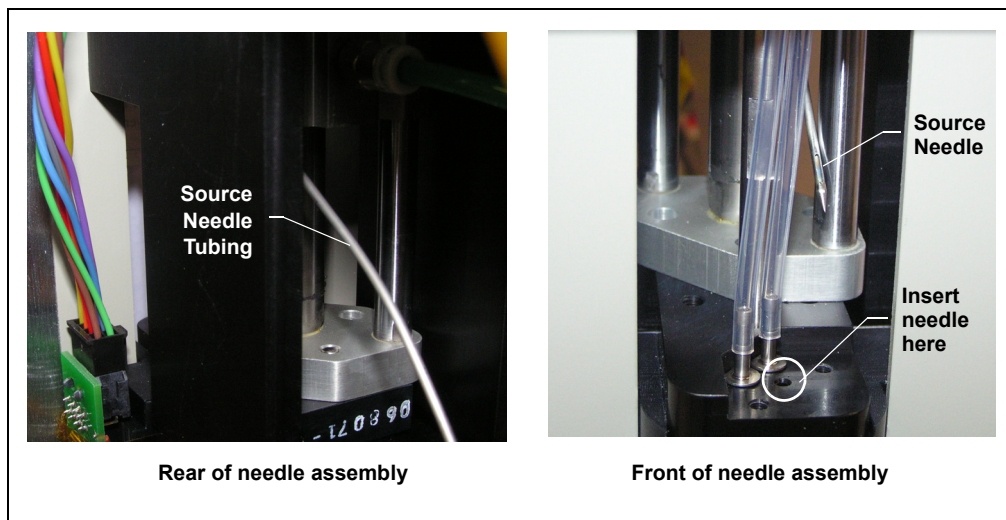

Figure 5-26. Routing the New Source Needle to the Needle Block

- With the eye of the source needle facing toward the front of the needle block, insert the source needle into the middle opening on the needle block (see [Figure 5-26](#)), just until it stops.

IMPORTANT Be careful when handling the source needle. The tip of the needle is sharp; in addition, it is fragile and can easily be bent.

- Replace the cover on the needle block and reinstall the screws.
- Connect the free end of the source needle tubing to the side of the static valve.
- Follow the instructions on [page 75](#) to reinstall the right-side panel.
- Turn on the Dionex ASE 150 main power switch.
- Reconnect the gas source at the Dionex ASE 150 rear panel and turn on the gas supply.

5.10 Replacing the Main Power Fuses

1. Turn off the Dionex ASE 150 power switch and disconnect the power cord from both its source and from the Dionex ASE 150 rear panel.



HIGH VOLTAGE—Disconnect the main power cord from its source, as well as from the rear panel of the Dionex ASE 150.



HAUTE TENSION—Débranchez le cordon d'alimentation principal de sa source et du panneau arrière du Dionex ASE 150.



HOCHSPANNUNG—Ziehen Sie das Netzkabel aus der Steckdose und der Netzbuchse auf der Rückseite des Dionex ASE 150.

2. The fuse drawer is located above the main power switch (see [Figure 5-27](#)). A small tab locks the fuse drawer in place. Using a small screwdriver, press the tab *in* and *then up* to release the fuse drawer.
3. Pull the fuse drawer out of the rear panel and remove the old fuses. Thermo Fisher Scientific recommends always replacing *both* fuses.
4. Insert two new 10 amp IEC127 fast-blow fuses (P/N 954746) into the springs in the fuse drawer. Press gently to fully insert the fuses into the drawer.

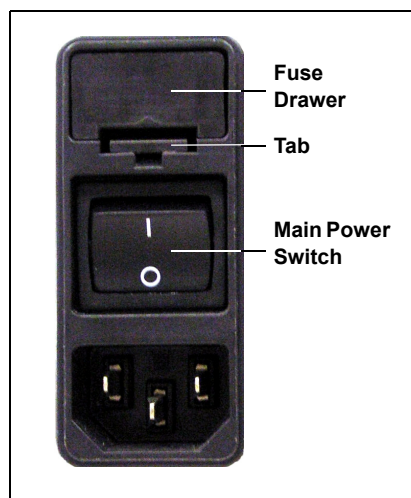

Figure 5-27. Fuse Drawer

5. Insert the fuse drawer into the rear panel and press until the drawer snaps into place.
6. Reconnect the power cord and turn on the power switch.

A.1 Electrical

Power Recommendations	100 to 120 Vac <i>or</i> 220 to 240 Vac, 50/60 Hz. The Dionex ASE 150 power supply is auto-sensing and requires no manual voltage or frequency adjustment.
Power Limitations	The Dionex ASE 150 is functional at a low of 90 Vac and a high of 264 Vac.
Typical Operating Power	500 W
Maximum Operating Power	1000 W
Maximum Line Draw	8 A at 110 Vac
Oven Power Requirements	Two switches set the oven voltage to 110 (for power source voltages between 100 and 120 Vac) or 220 (for power source voltages between 220 and 240 Vac).
Fuse Requirements	Two IEC127 fast-blow fuses rated at 10 A (P/N 954746)

A.2 Environmental

Operating Temperature	4 to 40 °C (39 to 104 °F) Note: The Dionex ASE 150 is intended for indoor operation only.
Operating Humidity	5% to 95% relative humidity (noncondensing)

A.3 Physical

Dimensions	56 cm high (excluding solvent reservoir) x 36 cm wide x 46 cm deep (22 in x 14 in x 18 in) 6 cm (2.5 in) clearance required behind the system
Weight	34 kg (75 lb)

A.4 Pneumatic

Nitrogen	0.97 to 1.38 MPa (140 to 200 psi)
-----------------	-----------------------------------

A.5 Front Panel Display and Keypad

Display	Vacuum fluorescence display (VFD)
Keypad	Seven buttons for entering commands and selecting screen parameters

A.6 Sample Cells

Stainless Steel Sample Cells	Stainless steel cell bodies and end caps with PEEK seals and stainless steel frits. Cells are available in the following sizes: 1 mL (actual volume: 1.0 mL) 5 mL (actual volume: 5.0 mL) 10 mL (actual volume: 10.0 mL) 22 mL (actual volume: 22.0 mL) 34 mL (actual volume: 34.0 mL) 66 mL (actual volume: 66.0 mL) 100 mL (actual volume: 99.8 mL)
Zirconium Sample Cells	Zirconium cell bodies and end caps with PEEK seals and zirconium frits. Cells are available in the following sizes: 66 mL (66.0 mL actual volume) 100 mL (99.8 mL actual volume)

A.7 Collection Vessels

Collection Vessels	60-mL vials and 250-mL bottles; the cap septum is PTFE-coated on the solvent side
---------------------------	---

A.8 Interior Components

Oven	Heats from 40 to 200 °C; the oven turns off automatically after eight hours of no system activity.
Pump	Operating pressure of 10.35 MPa (1500 psi)
Valves	High-pressure valves: pressure relief and static Low-pressure valves: purge, prime, and pneumatics
Bottle Sensor	When the needles are in the “down” position, sensors detect whether a collection vessel is present and whether it is full.
Hydrocarbon Sensor	Monitors the hydrocarbon vapor level
Cell Sensor	When the cell door is closed, the sensor can detect whether a cell is installed in the cell holder.

B.1 Facility Requirements

- Install the Thermo Scientific Dionex ASE 150 Accelerated Solvent Extractor on a sturdy table or workbench in a location that minimizes Dionex ASE 150 exposure to direct sunlight. Allow at least 6 cm (2.5 in) of free space behind the Dionex ASE 150 for connections and ventilation.



Lift the Dionex ASE 150 only from the bottom and/or sides of the instrument. If the system is lifted from the front, the drip tray may slide forward. Use caution when lifting the Dionex ASE 150: it weighs 34 kg (75 lb).



Ne soulevez le Dionex ASE 150 que par le fond ou les côtés. Soyez prudent lorsque vous soulevez le Dionex ASE 150: il pèse 34 kg.



Wenn Sie den Dionex ASE 150 anheben oder bewegen möchten, greifen Sie bitte unter den Boden oder heben Sie das Gerät an den Seiten an. Seien Sie vorsichtig, wenn Sie den Dionex ASE 150 anheben. Das Gerät wiegt 34 kg.

- Provide a source of 99.9% pure nitrogen gas, regulated to between 0.97 and 1.38 MPa (140 and 200 psi); 1.03 MPa (150 psi) is recommended. Applications that use a very clean baseline electron capture detector (ECD) may require UHP (ultra-high purity) gas.
- Provide a grounded, single-phase power source of 100 to 240 Vac, 50/60 Hz. The oven voltage switches must be set to match the voltage from the power source at the installation site: **110** (for voltages between 100 and 120 Vac) or **220** (for voltages between 220 and 240 Vac). For details, see [Section B.2.3](#).

B.2 Installation Instructions

Before beginning the installation procedure, locate the Dionex ASE 150 Ship Kit (P/N 066399). The Ship Kit contains several items required to install the system. In addition, you will need a Dionex ASE 150 Startup Kit appropriate for the sample cell size you plan to use. The following Startup Kits are available:

Dionex ASE 150 Startup Kit	Part Number
Startup Kit for 1-mL, 5-mL, 10-mL, and 22-mL sample cells	068250
Startup Kit for 34-mL sample cells	068251
Startup Kit for 66-mL sample cells	068252
Startup Kit for 100-mL sample cells	068253

B.2.1 Connecting the Nitrogen Gas Source

The nitrogen gas source connection on the Dionex ASE 150 rear panel (see [Figure B-1](#)) is a press fitting.

- To *connect* a press fitting, firmly push the tubing into the fitting until it is seated.
- To *disconnect* a press fitting, use your fingers (or a small open-end wrench) to press the ring on the fitting *in*, while at the same time pulling the tubing *out*.

1. Connect the 4-mm (0.156-in) elbow fitting (P/N 049272) to the regulator on the nitrogen gas source.
2. Push one end of the blue 4-mm (0.156-in) OD tubing (P/N 049296) into the elbow fitting.
3. Push the other end of the tubing into the **NITROGEN** connector on the Dionex ASE 150 rear panel (see [Figure B-1](#)).

4. Adjust the nitrogen pressure source to between 0.97 and 1.38 MPa (140 and 200 psi); 1.03 MPa (150 psi) is recommended.
5. Push one end of the clear 8-mm (0.312-in) OD tubing (P/N 053514) into the **VENT** connector (see [Figure B-1](#)).
6. (*Optional*) Route the free end of the vent tubing to a vent hood.



Figure B-1. Dionex ASE 150 Rear Panel



Do not obstruct or pressurize the vent outlet.



Ne bloquez ni ne mettez sous pression la sortie d'aération.



Halten Sie den Lüftungsauslaß frei, setzen Sie ihn nicht unter Druck.



Make sure the vent tubing runs downhill from the Dionex ASE 150 rear panel. This prevents formation of a trap, which would prevent vapors from being vented through the tubing.

B.2.2 Connecting the Drain Hose

1. Push one end of the convoluted hose (P/N 055075) onto the drain fitting on the Dionex ASE 150 rear panel.
2. Route the free end of the hose to waste.

B.2.3 Checking the Oven Voltage Switches

1. Verify that the settings of both oven voltage switches on the Dionex ASE 150 rear panel (see [Figure B-2](#)) match the voltage from the power source at the installation site: either **110** (for voltages between 100 and 120 Vac) or **220** (for voltages between 220 and 240 Vac).

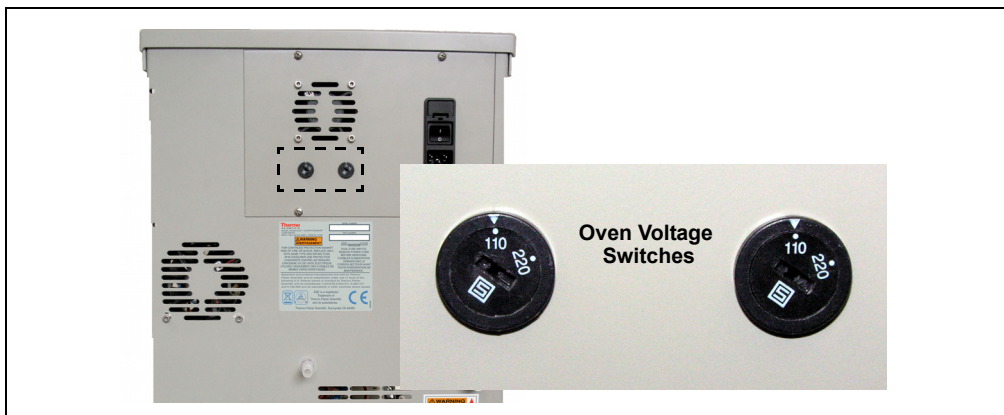

Figure B-2. Oven Voltage Switches

2. If you need to change an oven voltage switch setting:
 - a. Verify that the main power switch on the Dionex ASE 150 rear panel is turned off.
 - b. Insert a small screwdriver into the slot in each switch and turn it to either **110** or **220**.

NOTE The oven voltage switch settings affect only the oven and have no effect on any other system components. The Dionex ASE 150 main power supply adjusts automatically to the power source at the installation site.

B.2.4 Connecting the Power Cord

1. Verify that the main power switch on the Dionex ASE 150 rear panel is turned off.
2. Connect a modular power cord (IEC 320 C13) from the main power receptacle on the Dionex ASE 150 rear panel to a grounded, single-phase power source of 100 to 240 Vac, 50/60 Hz.



SHOCK HAZARD—To avoid electrical shock, use a grounded receptacle. Do not operate the Dionex ASE 150 or connect it to AC power mains without an earthed ground connection.



The power supply cord is used as the main disconnect device. Make sure the socket-outlet is located near the Dionex ASE 150 and is easily accessible.



Operation at AC input levels outside of the specified operating voltage range may damage the Dionex ASE 150.



DANGER D'ÉLECTROCUTION—Pour éviter toute électrocution, il faut utiliser une prise de courant avec prise de terre. Ne l'utilisez pas et ne le branchez pas au secteur C.A. sans utiliser de branchement mis à la terre.



Le cordon d'alimentation principal est utilisé comme dispositif principal de débranchement. Veillez à ce que la prise de base soit située/installée près du module et facilement accessible.



STROMSCHLAGGEFAHR—Zur Vermeidung von elektrischen Schlägen ist eine geerdete Steckdose zu verwenden. Das Gerät darf nicht ohne Erdung betrieben bzw. an Wechselstrom angeschlossen werden.



Das Netzkabel ist das wichtigste Mittel zur Stromunterbrechung. Stellen Sie sicher, daß sich die Steckdose nahe am Gerät befindet und leicht zugänglich ist.

B.2.5 Checking Pressure Readings

1. Turn on the main power switch on the Dionex ASE 150 rear panel.
2. On the **MENU** screen, select **DIAGNOSTICS** and press **ENTER** to display the **DIAGNOSTICS** screen (see [Figure B-3](#)).

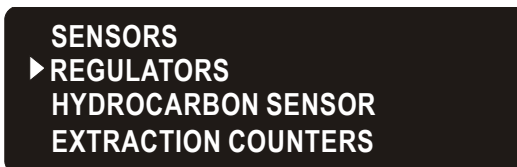

Figure B-3. Diagnostics Screen

3. Select **REGULATORS** and press **ENTER** to display the **REGULATORS** screen (see [Figure B-4](#)).

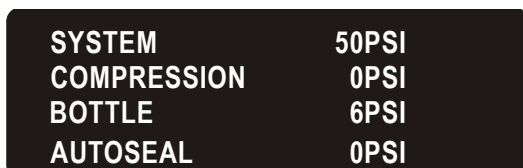

Figure B-4. Regulators Screen

NOTE The **COMPRESSION** and **AUTOSEAL** pressure readings are zero unless a run is in progress.

4. Compare the pressure readings on the **REGULATORS** screen with the values listed in the table below. If a pressure reading does not meet specification, contact Thermo Fisher Scientific.

Field	Function	Specification
SYSTEM	Internal system pressure	0.34 ± 0.02 MPa (50 ± 3 psi)
COMPRESSION	Pressure applied when the oven is compressed	0.90 ± 0.03 MPa (130 ± 5 psi)
BOTTLE	Pressure applied to the solvent reservoir	0.03 to 0.07 MPa ^a (4 to 10 psi)
AUTOSEAL	Pressure applied when the AutoSeal air cylinder is actuated	0.14 ± 0.01 MPa (21 ± 2 psi)

a) Nominally set for 0.04 MPa (6 psi). The pressure may increase during periods of system inactivity, but will return to a value within the specification as soon as a run begins.

B.2.6 Connecting the Solvent Reservoir



Use only Thermo Fisher Scientific solvent reservoirs. These are glass bottles with a plastic, shatterproof coating. To prevent personal injury, make sure the pressure applied to the bottles does not exceed 0.07 MPa (10 psi).



Utilisez uniquement des réservoirs à solvant Thermo Fisher Scientific. Ce sont des réservoirs en verre à revêtement incassable en plastique. Veillez à ce que la pression exercée sur ces réservoirs ne dépasse pas 0,07 MPa.



Verwenden Sie ausschließlich die Lösemittelbehälter von Thermo Fisher Scientific. Dabei handelt es sich um Glasbehälter mit einer splittersicheren Plastikbeschichtung. Vergewissern Sie sich, daß der Druck, der auf die Behälter ausgeübt wird, 0,07 MPa nicht übersteigt.



Never fill the solvent reservoir or disconnect the tubing connections to the solvent and gas connectors during a run or rinse cycle. At these times, the solvent reservoir is pressurized. If you remove the bottle cap when the solvent reservoir is pressurized, the Dionex ASE 150 may not operate to specification.

1. If you plan to run a preprogrammed method, refer to [Section 2.5](#) for the recommended solvent. If you plan to run a custom method, review the solvent selection guidelines in [Section 3.1.1](#).
2. Fill the solvent reservoir with prepared solvent to the level indicated in [Figure B-5](#).

NOTE The solvent level in the reservoir must remain below the gas inlet line, to prevent solvent from coming into contact with the pneumatic valves.

3. Place the solvent reservoir in the recess on top of the Dionex ASE 150.
4. Insert the solvent outlet line extending from the underside of the cap assembly (P/N 051977) into the solvent reservoir (see [Figure B-5](#)). Make sure the end-line filter rests on the bottom of the bottle.

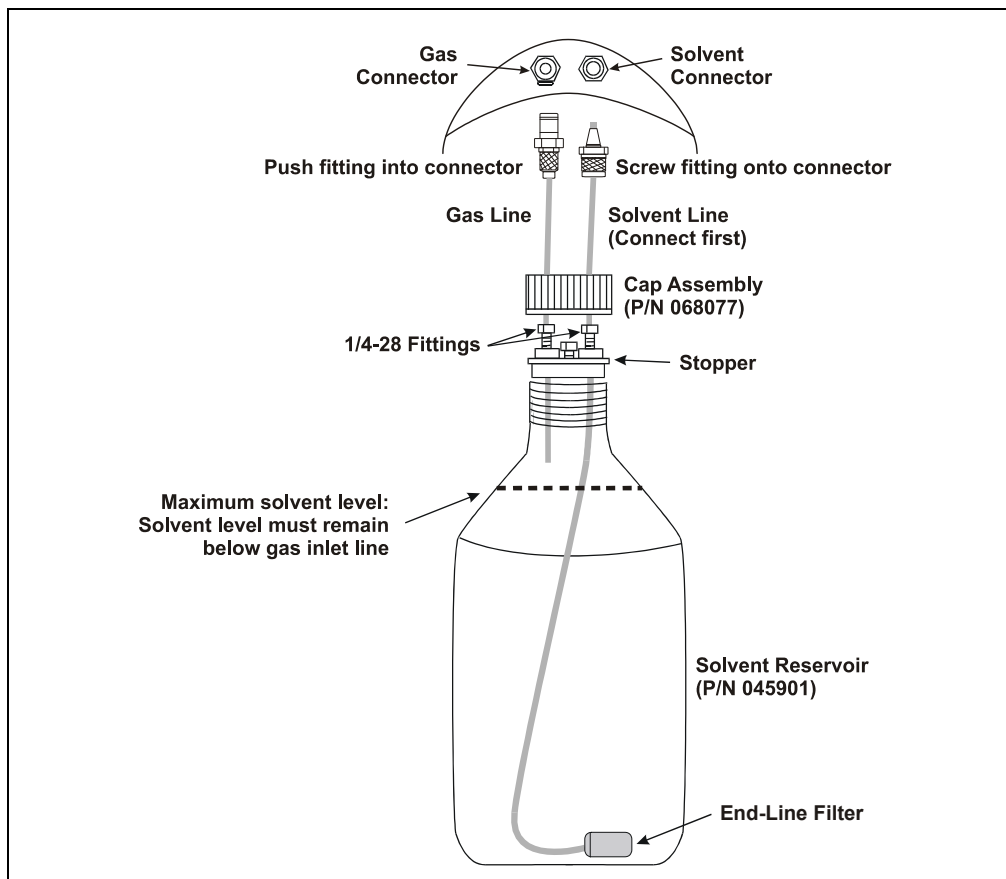

Figure B-5. Solvent Reservoir Connections (Top View)

5. Hand-tighten the lock ring cap securely over the stopper.
6. Screw the fitting on the solvent outlet line into the solvent connector.
7. Push the fitting on the gas inlet line into the gas connector. (To disconnect the line, push the small latch at the top of the connector toward the center of the connector.)

NOTE Always connect the solvent line to the solvent connector first, and then the gas line to the gas connector. Reverse this order when disconnecting the lines. It is not necessary to disconnect the solvent and gas lines before refilling the solvent reservoir.

B.2.7 Installing the Waste Bottle

Use a 250-mL collection bottle (without a cap) for the waste bottle.

1. Open the waste door.
2. Tilt the waste bottle at a slight angle and position it below the built-in bottle cap.
3. While being careful not to bend the tubing that extends from the bottle cap, insert the bottle into the bottle cap.
4. Tilt the cap and bottle toward you and screw the bottle into the cap.
5. Hand-tighten the bottle onto the cap to ensure a good seal.
6. Release the bottle, allowing it to swing gently into place.
7. Close the waste door.



Figure B-6. Installing the Waste Bottle

B.2.8 Adjusting the Cell Holder

When the Dionex ASE 150 is shipped from the factory, the cell holder is positioned to hold a 100-mL sample cell (or a long rinse cell). To accommodate a cell of any other size, move the lower latch of the cell holder (see [Figure B-7](#)) to the appropriate mounting site on the cell door (see [Figure B-8](#)).



CAUTION



MISE EN GARDE



VORSICHT

If the Dionex ASE 150 has recently finished a run, the inside of the cell door will be hot. Put on thermal gloves (P/N 060372) before adjusting the cell holder.

Si l'ASE 150 a récemment fini l'extraction, la température du four sera élevée. Utilisez des gants de protection thermique (P/N 060372) avant de toucher le four ou la cellule d'extraction.

Wenn der Dionex ASE 150 gerade einen Lauf beendet hat, ist die Zellentür auf der Innenseite heiß. Tragen Sie daher Handschuhe (P/N 060372), wenn Sie den Zellenhalter justieren.

1. Push the **OPEN** lever down and open the cell door.
2. Use a 3-mm hex screwdriver (P/N 060154) to remove the two hex screws (P/N 046253) securing the lower latch to the cell door (see [Figure B-7](#)).



Figure B-7. Removing the Cell Holder Lower Latch

3. Position the latch in the new location on the cell door (see [Figure B-8](#)) and install the hex screws. The Dionex ASE 150 Ship Kit (P/N 066399) includes two extra hex screws, in case the original screws are misplaced.

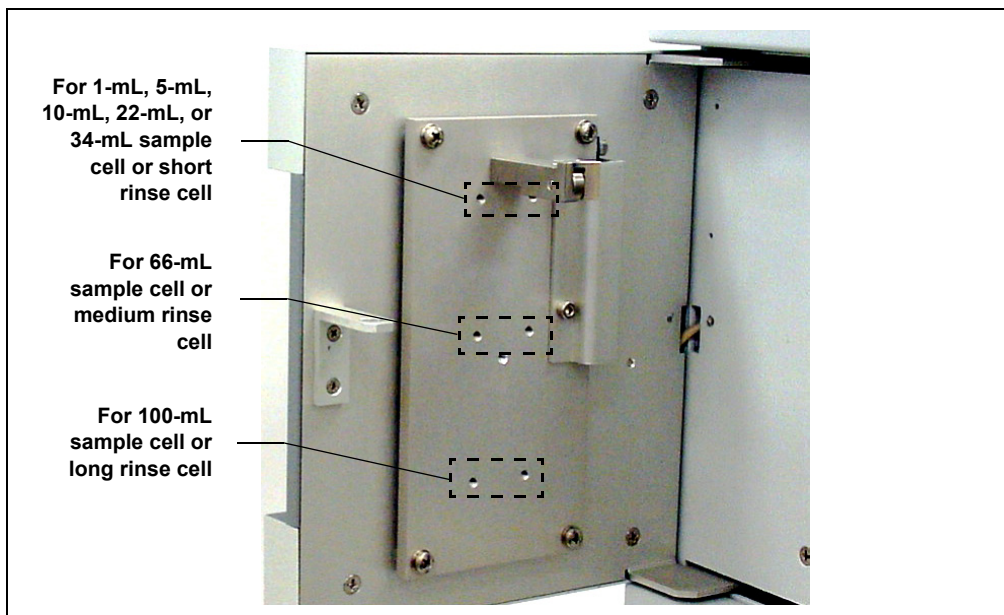

Figure B-8. Mounting Sites for the Cell Holder Lower Latch

NOTE When the latch is correctly installed, the small tab is on the underside of the latch (see [Figure B-7](#)).

B.2.9 Selecting Setup Options

1. On the **MENU** screen, press an arrow button to move the cursor to **SETUP**, and then press **ENTER** to display the **SETUP** screen (see [Figure B-9](#)). All parameters do not fit on one screen. To view additional parameters, press the down arrow button.

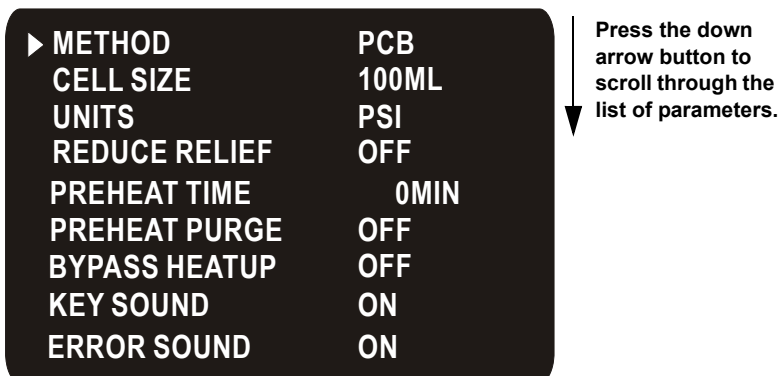

Figure B-9. Setup Screen (All Parameters Shown)

2. Specify the method to run, the sample cell size, and other Dionex ASE 150 operating parameters. [Table B-1](#) describes each setup parameter.
3. To change a setting:
 - a. Press an arrow button to move the cursor to the first parameter that you want to change (for example, **CELL SIZE**).
 - b. Press **ENTER**. The cursor moves to the editing field.

NOTE If you decide not to edit this field, press **MENU** to return the cursor to the left margin of the screen.

- c. Press an arrow button to step through the values allowed for the highlighted value. (Pressing and holding the arrow button steps through the values more rapidly.) When the required value is displayed, press **ENTER**.

Parameter	Description
METHOD	Specifies the name or number of the method to run.
CELL SIZE	Specifies which sample cell is installed (1 mL, 5 mL, 10 mL, 22 mL, 34 mL, 66 mL, or 100 mL). This setting determines solvent volumes and temperature settings.
UNITS	Selects the unit of measure for pressure displays (psi, MPa, bar, or atm).
REDUCE RELIEF	Determines whether the pressure relief valve is open for a reduced period (ON) or the normal period (OFF). When the pressure relief valve is open, residual pressure is released from the sample cell. The default setting (OFF) is recommended.
PREHEAT TIME	Specifies for how long the oven heats up without solvent (0 to 99 minutes). The default setting (0) is recommended.
PREHEAT PURGE	Enables and disables purging of the cell (without solvent) during the preheat period. The default setting (OFF) is recommended.
BYPASS HEAT-UP	Specifies whether to bypass the heat-up period for the sample cell. The default setting (OFF) is recommended.
KEY SOUND	Determines whether a beep is emitted when a keypad button is pushed.
ERROR SOUND	Determines whether a beep is emitted when an error occurs (for example, you press the wrong keypad button).

Table B-1. System Setup Parameters

B.2.10 Rinsing the System

Selecting the Rinse Cell

Rinse cells are similar to sample cells, but they are blue in color. The rinse cell size (short, medium, or long) must be matched to the sample cell size (see the table below). Each Dionex ASE 150 Startup Kit (see [Section B.2](#)) includes one rinse cell in the size required for the sample cell to be used.

Use this rinse cell:	With this sample cell:
Short (P/N 060174)	1 mL, 5 mL, 10 mL, 22 mL, 34 mL
Medium (P/N 060175)	66 mL
Long (P/N 060176)	100 mL

Inspecting Cell O-Rings

Before each use, inspect the O-rings installed in the exterior ends of each rinse cell and sample cell end cap (see [Figure B-10](#)).

- If an O-ring is dislodged, press it into place, using the O-ring insertion tool (P/N 049660).

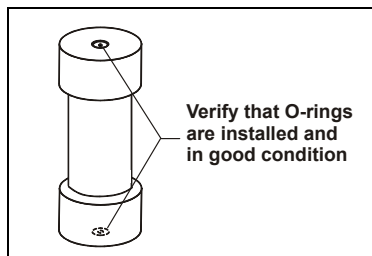

Figure B-10. Inspecting Cell O-Rings

- If an O-ring is missing, install a new one (see [Figure B-11](#)).
- If any O-ring has a hole size of less than 0.5 mm, replace it. If a white PTFE O-ring is discolored, replace it (for instructions, see [page 38](#)).

PTFE O-rings (P/N 049482, pkg. of 10) are included in the Dionex ASE 150 Startup Kits. Viton O-rings (P/N 056325, pkg. of 50) are available for dioxins and other high temperature applications.

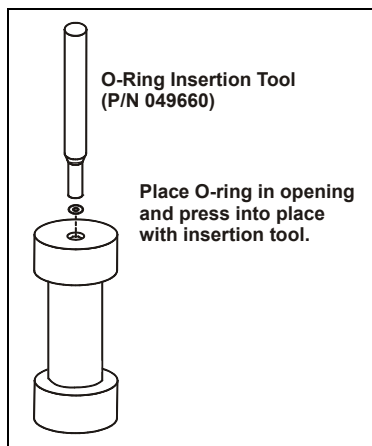

Figure B-11. Installing Cell O-Rings

Installing the Rinse Cell in the Cell Holder

The installation procedure is the same for rinse and sample cells. A sample cell is shown in the photos.

1. Open the cell door.
2. While holding the cell at a slight angle, position the bottom end cap under the bottom latch of the cell holder.
3. Raise the cell so that the bottom end cap lifts the bottom latch.
4. Straighten the cell until it is vertical and then lower it until the top end cap rests on the top latch of the cell holder.
5. Close the cell door.

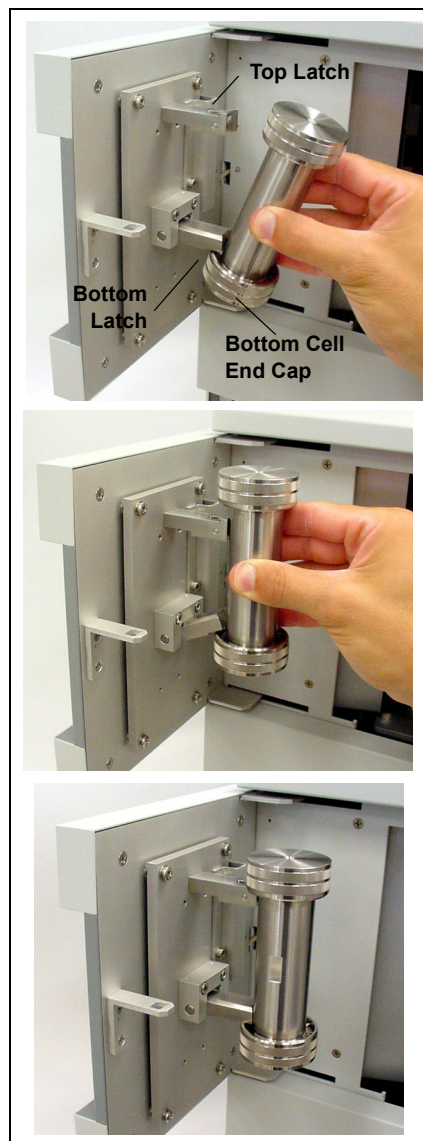

Figure B-12. Installing a Sample Cell

Starting the Rinse Cycle



Before each run, carefully inspect all collection vessels for chips, scratches, or cracks. If you notice any signs of damage, dispose of the collection vessel.

Use each nongraduated collection vessel once only. Graduated collection vessels may be used multiple times, provided they are undamaged.



La présence de fêlure ou d'égratignures sur les flacons de collecte doit être vérifiée avant chaque extraction. N'utilisez jamais un flacon endommagé.

Les flacons non gradués sont à usage unique. Les flacons gradués peuvent être réutilisés tant qu'ils sont intacts.



Untersuchen Sie vor jedem Lauf alle Sammelgefäße auf Abplatzungen, Kratzer oder Risse. Wenn ein Sammelgefäß eine Beschädigung aufweist, sollten Sie es nicht mehr verwenden.

Graduierte Sammelgefäße können mehrfach verwendet werden, vorausgesetzt sie weisen keine Beschädigung auf.



Use each collection vessel cap and septum once only. This prevents solvent leaks caused by piercing the septum in the cap multiple times.

1. Open the collection vessel compartment door and toggle the needle switch to the **UP** position (see [Figure B-13](#)).

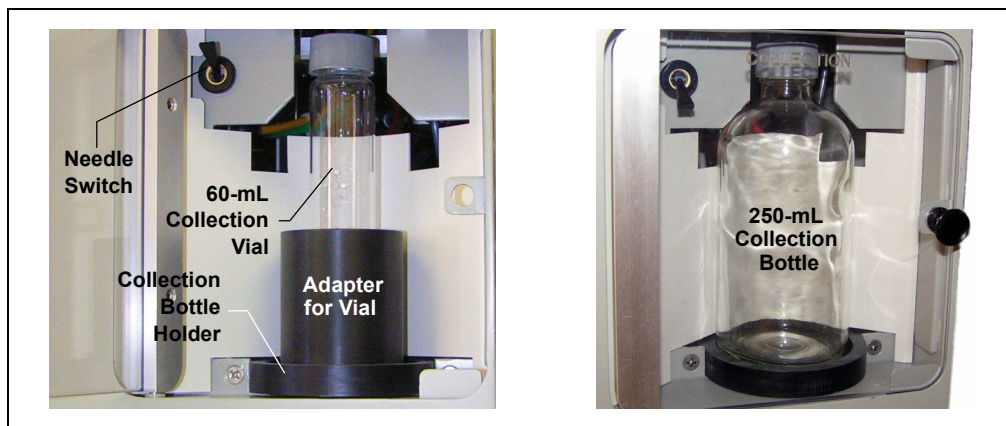

Figure B-13. Installing the Collection Vessel

2. If you are using a 60-mL collection vial, place the vial into the adapter (P/N 066392) and then place the adapter on the collection

bottle holder (see [Figure B-13](#)). If you are using a 250-mL collection bottle, place the bottle directly on the collection bottle holder.

3. Toggle the needle switch to the **DOWN** position.
4. Close the door.
5. Press **RINSE** to begin the rinse cycle. The LED on the **RINSE** button turns on and will remain lighted while the rinse cycle is in progress.
6. When the rinse cycle is complete (after about 1 minute), three beeps are emitted and the **RINSE** button LED turns off.
7. Remove the rinse cell:
 - a. If the oven is hot, put on the thermal gloves (P/N 060372) provided in the Dionex ASE 150 Ship Kit (P/N 066399).
 - b. Remove the rinse cell from the cell holder, and place it on the cell rack (P/N 059927) to cool.
 - c. Close the cell door until the next run, to save energy and prevent anyone from accidentally touching a hot surface.
8. Remove the collection vessel used for the rinse cycle.

C • User Interface

This appendix describes all of the screens that can be displayed on the Thermo Scientific Dionex ASE 150 Accelerated Solvent Extractor front panel (see [Figure C-1](#)). There are two functional categories for screens: operational and diagnostic.

- *Operational* screens let you select certain default parameters for the Dionex ASE 150, run the methods that control a run, and create and edit custom methods.
- *Diagnostic* screens let you monitor input from sensors, monitor pressure settings, adjust the solvent vapor threshold, check the usage of certain parts, and check which version of Dionex ASE 150 firmware is installed.

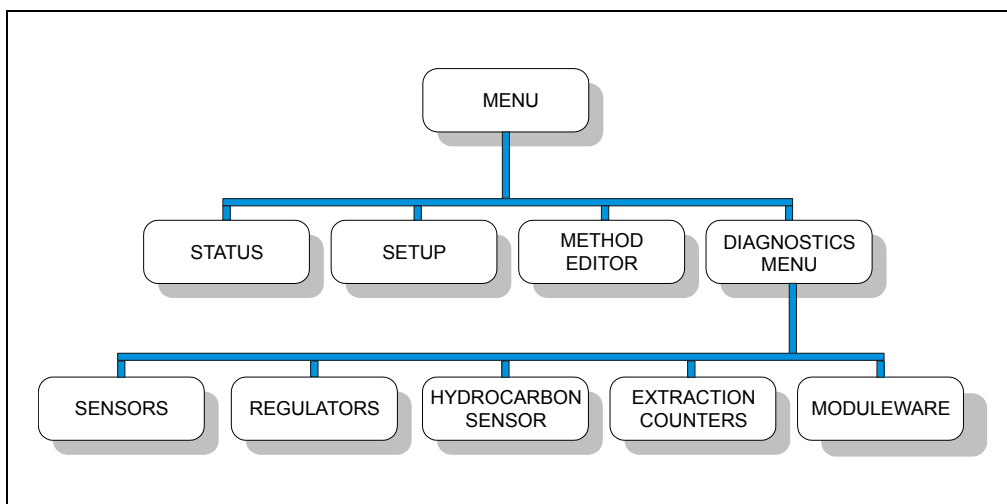

Figure C-1. Overview of Dionex ASE 150 Screens

C.1 Operational Screens

C.1.1 Menu Screen

The **MENU** screen provides access to the Dionex ASE 150 operational and diagnostics screens. To display the **MENU** screen, press the **MENU** button on the front panel.



Figure C-2. Menu Screen

To display a screen listed on the **MENU**:

1. Press an up or down arrow button to move the cursor to the screen name.
2. Press **ENTER**.

C.1.2 Status Screen

Use the **STATUS** screen to monitor the progress of a method run. The screen is updated three times per second. You cannot edit any information on this screen.



STATUS	OVEN READY		
METHOD	PCB	VOL	0mL
PRESSURE		0PSI	
TEMP	100C	TIME	5:00

Figure C-3. Status Screen

Parameter	Description
STATUS	The current system status. The following status values are displayed as they occur: Initialize, Idle, Load, Fill, Preheat, Heat, Oven Wait, Oven Ready, Static, Rinse, Purge, Relief, Unload, Rinse, or Abort. If the status is Static or Rinse, the cycle number is indicated.
METHOD	The name or number of the current method.
VOL	The approximate volume (in mL) of solvent delivered by the pump since the method started.
PRESSURE	The current pressure reading. Select the unit of measure on the SETUP screen (see Section C.1.3).
TEMP	The oven temperature specified in the method.
TIME	The elapsed time (in minutes and seconds) since the method started running.

C.1.3 Setup Screen

Use the **SETUP** screen to specify the method to run, the sample cell size, and other Dionex ASE 150 operational parameters. All parameters do not fit on one screen. To view additional parameters, press the down arrow button.

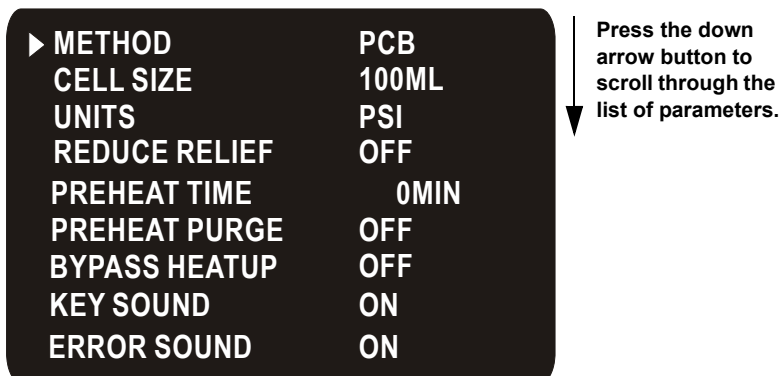

Figure C-4. Setup Screen (All Parameters Shown)

Parameter	Description
METHOD	Specifies the name or number of the method to run.
CELL SIZE	Specifies the sample cell installed (1 mL, 5 mL, 10 mL, 22 mL, 34 mL, 66 mL, or 100 mL). The Dionex ASE 150 determines various internal operating parameters (for example, the rinse volume) based on the selected cell size.
UNITS	Specifies the unit of measure for pressure displays (psi, MPa, bar, or atm).
REDUCE RELIEF	Determines whether the pressure relief valve is open for a reduced period (ON) or the normal period (OFF). When the pressure relief valve is open, residual pressure is released from the sample cell. The default setting (OFF) is recommended.
PREHEAT TIME	Specifies for how long the oven heats up without solvent (0 to 99 minutes). The default setting (0) is recommended.
PREHEAT PURGE	Enables and disables purging of the cell (without solvent) during the preheat period. The default setting (OFF) is recommended.

Parameter	Description
BYPASS HEAT-UP	Specifies whether to bypass the heat-up period for the sample cell. The default setting (OFF) is recommended.
KEY SOUND	Turns on and off the beep that sounds when a keypad button is pushed.
ERROR SOUND	Turns on and off the beep that sounds when an error occurs.

C.1.4 Method Editor Screen

Use the **METHOD EDITOR** screen to define the parameters in a custom method. When a preprogrammed method is selected, the method parameters cannot be edited. All parameters do not fit on one screen. To view additional parameters, press the down arrow button.

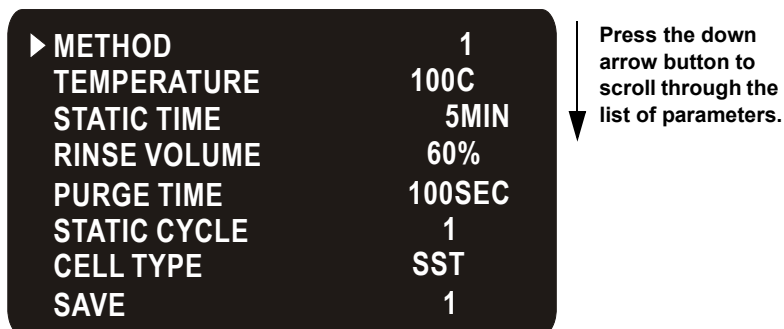

Figure C-5. Method Editor Screen (All Parameters Shown)

Parameter	Description
METHOD	Displays the number (1 through 24) or name of the method currently selected for editing. See Section 2.5 for the names and descriptions of the preprogrammed methods.
TEMPERATURE	Specifies the temperature at which the sample cell is heated (Off, 40 to 200 °C).
STATIC TIME	Static (extraction) time—the number of minutes (0 to 99) to maintain the cell contents (sample and solvent) at the temperature set point.

Parameter	Description
RINSE VOLUME	Specifies the volume of solvent rinsed through the cell after the static heating step, expressed as a percentage of the cell volume (0% to 150%). For example, if the RINSE VOLUME is 50%, 5 mL of solvent is rinsed through a 10-mL cell, 17 mL of solvent is rinsed through a 34-mL cell, and so on.
PURGE TIME	Specifies the amount of time the cell is purged with nitrogen (0 to 900 seconds). Thermo Fisher Scientific recommends the following settings: <ul style="list-style-type: none">• 40 to 80 seconds for a 1-mL, 5-mL, 10-mL, or 22-mL cell• 70 to 110 seconds for a 34-mL cell• 160 to 200 seconds for a 66-mL cell• 250 to 290 seconds for a 100-mL cell
STATIC CYCLE	Specifies the number of times the static heating and rinsing steps are performed (1 to 5). If more than one cycle is specified, the rinse volume is divided among the cycles.
CELL TYPE	Specifies the type of cell used: SST (stainless steel) or Zr (zirconium).
SAVE	Specifies the method number (1 through 24) under which the selected parameters are saved. This field is not available when a preprogrammed method is selected.

C.2 Diagnostic Screens

C.2.1 Diagnostics Menu

The **DIAGNOSTICS MENU** screen provides top-level access to Dionex ASE 150 diagnostic screens. All parameters do not fit on one screen. To view additional parameters, press the down arrow button.

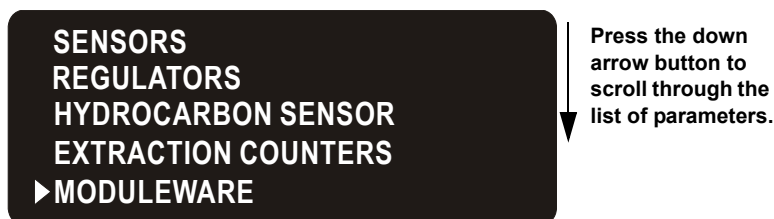

Figure C-6. Diagnostics Screen (All Parameters Shown)

To display the **DIAGNOSTICS MENU**:

1. Press **MENU** to display the **MENU** screen (see [Section C.1.1](#)).
2. Press an up or down arrow button to move the cursor to the **DIAGNOSTICS** option, and then press **ENTER**.

To display a diagnostics screen, press an up or down arrow button to move the cursor to the screen name and press **ENTER**.

C.2.2 Sensors Screen

Use the **SENSORS** screen to monitor information reported by various internal sensors. You cannot edit any information on this screen.

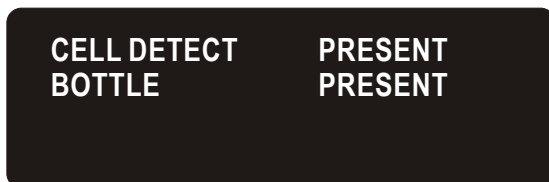

Figure C-7. Sensors Screen

Parameter	Description
CELL DETECT	When the cell door is closed, the sensor can detect whether a cell is installed in the cell holder. The sensor cannot identify which type of cell is installed.
BOTTLE	When the needles are in the “down” position, the sensor can detect whether a collection vessel is present in the holder.

C.2.3 Regulators Screen

Use the **REGULATORS** screen to monitor various pressure readings for the Dionex ASE 150. You cannot edit any information on this screen.

NOTE Select the unit of measure for on-screen pressure readings on the **SETUP** screen (see [Section C.1.3](#)).

SYSTEM	50PSI
COMPRESSION	0PSI
BOTTLE	6PSI
AUTOSEAL	0PSI

Figure C-8. Regulators Screen

NOTE The **COMPRESSION** and **AUTOSEAL** pressure readings are zero unless a run is in progress.

Parameter	Description	Specification
SYSTEM	Indicates the internal system pressure.	0.34 ± 0.02 MPa (50 ± 3 psi)
COMPRESSION	Indicates the pressure applied when the oven is compressed	0.90 ± 0.03 MPa (130 ± 5 psi)
BOTTLE	Indicates the pressure applied to the solvent reservoir	0.03 to 0.07 MPa ^a (4 to 10 psi)
AUTOSEAL	Indicates the pressure applied when the AutoSeal air cylinder is actuated	0.14 ± 0.01 MPa (21 ± 2 psi)

a. Nominally set for 0.04 MPa (6 psi). The pressure may increase during periods of system inactivity, but will return to a value within the specification range as soon as a run begins.

C.2.4 Hydrocarbon Sensor Screen

Use the **HYDROCARBON SENSOR** screen to monitor the hydrocarbon level at the Dionex ASE 150 installation site and to adjust the solvent vapor threshold, if necessary.

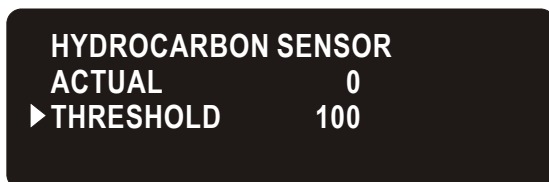

Figure C-9. Hydrocarbon Sensor Screen

Parameter	Description
ACTUAL	Indicates the hydrocarbon level detected by the hydrocarbon sensor.
THRESHOLD	Selects the solvent vapor threshold (10 to 10000). If the threshold is exceeded, an error occurs. If necessary, adjust the threshold to compensate for high background levels at the installation site.

C.2.5 Extraction Counters Screen

Use the **EXTRACTION COUNTERS** screen to check the number of extractions the system has run or the number of pump strokes performed, and to reset the counters. This can be helpful in scheduling the routine replacement of certain parts.

EXTRACTION	0
PUMP STROKE	0
▶ EXTR. RESET	READY
PUMP RESET	READY

Figure C-10. Extraction Counters Screen

Parameter	Description
EXTRACTION	Indicates the number of extractions performed since the Dionex ASE 150 was installed or the extraction counter was last reset.
PUMP STROKE	Indicates the number of pump strokes performed since the Dionex ASE 150 was installed or the pump stroke counter was last reset.
EXTR. RESET	Select RESET to reset the extraction counter to zero. Reset this counter after rebuilding the static valve (see Section 5.8).
PUMP RESET	Select RESET to reset the pump stroke counter to zero. Reset this counter after replacing the pump seals (see Section 5.6).

C.2.6 Moduleware Screen

The **MODULEWARE** screen indicates which version of Dionex ASE 150 Moduleware is currently installed. The **MODULEWARE** screen is also

displayed for a few seconds when the Dionex ASE 150 power is turned on.



Figure C-11. Moduleware Screen

D • Reordering Information

Part Number	Item	Quantity
<i>Sample Cells and Accessories</i>		
068095	Stainless steel sample cells, 1 mL (assembled)	Pkg. 6
068096	Stainless steel sample cells, 5 mL (assembled)	Pkg. 6
068097	Stainless steel sample cells, 10 mL (assembled)	Pkg. 6
068098	Stainless steel sample cells, 22 mL (assembled)	Pkg. 6
068099	Stainless steel sample cells, 34 mL (assembled)	Pkg. 6
068100	Stainless steel sample cells, 66 mL (assembled)	Pkg. 6
068101	Stainless steel sample cells, 100 mL (assembled)	Pkg. 6
068085	Stainless steel sample cell, 1 mL (assembled)	1
068086	Stainless steel sample cell, 5 mL (assembled)	1
068087	Stainless steel sample cell, 10 mL (assembled)	1
068088	Stainless steel sample cell, 22 mL (assembled)	1
068089	Stainless steel sample cell, 34 mL (assembled)	1
068090	Stainless steel sample cell, 66 mL (assembled)	1
068091	Stainless steel sample cell, 100 mL (assembled)	1
068261	Stainless steel sample cell body, 1 mL	1
068262	Stainless steel sample cell body, 5 mL	1
068263	Stainless steel sample cell body, 10 mL	1
068264	Stainless steel sample cell body, 22 mL	1
056646	Stainless steel sample cell body, 34 mL	1
056696	Stainless steel sample cell body, 66 mL	1
056693	Stainless steel sample cell body, 100 mL	1
056775	Stainless steel frits for sample cell end caps	Pkg. 50
068106	Stainless steel end caps for sample cells (includes frits and seals)	Pkg. 2
068104	Zirconium sample cells, 66 mL (assembled)	Pkg. 3
068105	Zirconium sample cells, 100 mL (assembled)	Pkg. 3

Part Number	Item	Quantity
068102	Zirconium sample cell, 66 mL (assembled)	1
068103	Zirconium sample cell, 100 mL (assembled)	1
068265	Zirconium sample cell body, 66 mL	1
068266	Zirconium sample cell body, 100 mL	1
068260	Zirconium frits for sample cell end caps	Pkg. 50
061687	PEEK seals for sample cell end cap	Pkg. 50
056778	Snap rings for sample cell end caps	Pkg. 10
056684	Snap ring tool	1
068107	Zirconium end caps for sample cells (includes frits and seals)	Pkg. 2
049457	External O-rings for sample cell end caps, PTFE	Pkg. 50
056325	External O-rings for sample cell end caps, Viton	Pkg. 50
049660	O-ring insertion tool	1
068093	Cellulose filters, 27 mm	Pkg. 100
056780	Cellulose filters, 30 mm	Pkg. 100
068092	Glass-fiber filters, 27 mm	Pkg. 100
056781	Glass-fiber filters, 30 mm	Pkg. 100
056929	Filter insertion tool	1
068076	Sample funnel (for 1-mL cells only)	1
068075	Sample funnel (for 5-mL, 10-mL, and 22-mL cells)	1
056699	Sample funnel (for 34-mL, 66-mL, and 100-mL cells)	1
059927	Cell cooling rack	1
060372	Thermal gloves	1 pair
<i>Startup Kits</i>		
068250	Startup Kit for 1-mL, 5-mL, 10-mL, and 22-mL sample cells	1
068251	Startup Kit for 34-mL sample cells	1
068252	Startup Kit for 66-mL sample cells	1
068253	Startup Kit for 100-mL sample cells	1
<i>Rinse Cells</i>		
060174	Rinse cell, short (for 1-mL, 5-mL, 10-mL, 22-mL, and 34-mL sample cells)	1

Part Number	Item	Quantity
060175	Rinse cell, medium (for 66-mL sample cells)	1
060176	Rinse cell, long (for 100-mL sample cells)	1
<i>Solvent Reservoir</i>		
045901	Bottle, plastic-coated glass, 2 L	1
068077	Bottle cap assembly	1
<i>Collection Vessels</i>		
056284	Collection bottles (clear), 250 mL (includes lids and septa)	Pkg. 12
068225	Collection bottle (clear), 250 mL, graduated, Class A (includes lid and septum)	1
068249	Collection bottle (clear), 250 mL, graduated, Class B (includes lid and septum)	1
048784	Collection vials (clear), 60 mL (includes lids and septa)	Pkg. 72
048781	Collection vials (amber), 60 mL (includes lids and septa)	Pkg. 72
068226	Collection vial (clear), 60 mL, graduated, Class A (includes lid and septum)	1
068248	Collection vial (clear), 60 mL, graduated, Class B (includes lid and septum)	1
055395	PTFE/silicone low-bleed septa for collection vessels Note: These are high-purity septa for trace analysis applications.	Pkg. 72
<i>Waste Bottle</i>		
060078	Waste bottle septum assembly (punched)	1
<i>Tubing</i>		
049296	Nitrogen line: 4-mm (0.16-in) OD tubing	Per inch
053514	Vent line: 8-mm (0.31-in) OD tubing	Per inch
<i>Pump</i>		
047755	Check valve cartridge, inlet	1
047664	Check valve assembly, inlet	1
057346	Check valve cartridge, outlet	1

Part Number	Item	Quantity
059791	Check valve assembly, outlet	1
066109	Piston guide	1
066110	Pump piston	1
066162	High-pressure seal	1
066163	Low-pressure air seal	1
<i>Static Valve</i>		
068115	Static Valve Repair Kit	1
068116	Static Valve Tool Kit	1
066165	Static valve seal	1
067381	Static valve piston	1
<i>Miscellaneous</i>		
954746	Fast-blow IEC127 fuse, 10 amps	1
068961	Source needle assembly	1
068247	Heat exchanger	1
062819	Pelletized diatomaceous earth (DE)	1 kg
080024	ASE Prep CR Resin	500 g

E.1 Introduction

Scientists are continually striving to develop means to accomplish desired results faster, better, cheaper, and more efficiently. However, the application of new technologies to sample preparation has often lagged behind the advances in the determinative steps of the overall analytical scheme. Consider the major technological changes in chromatography that have occurred in the last few years. What a contrast exists between the first commercial gas chromatographs (GC) introduced in the late 1950s and the modern GCs we have today! On the other hand, analytical chemists can still be seen preparing samples for chromatographic analysis using the same type of Soxhlet apparatus that was used to prepare samples for the first GC instruments. In fact, Soxhlet apparatus has been in use with few modifications for over 100 years. Traditional extraction techniques suffer from several shortcomings. They often take long periods of time (several hours), use large quantities of solvent (hundreds of milliliters per sample), and require a great deal of labor and user intervention.

In addition to the costs associated with sample preparation, studies have shown that the biggest bottleneck and source of errors in any analytical process are found in sample preparation. If we want to have the biggest impact on improving the performance of any analytical method, we would be well-advised to attack the sample preparation portion of the method. That is one reason that Thermo Fisher Scientific has been involved in research dealing with sample preparation for many years. Accelerated solvent extraction (ASE) was developed by Thermo Fisher Scientific to address the problems inherent with traditional extraction techniques, such as Soxhlet and sonication, that use copious amounts of solvent and long and laborious periods of time.

ASE is an automated extraction technique that uses elevated temperatures and pressures to achieve extractions in very short periods of time (for example, 10 g of sample can be extracted in less than 15 minutes, using less than 15 mL of solvent). Why would we do extractions at elevated temperatures and pressures? There are several physicochemical reasons for this. First, let's consider temperature.

It is a well-known fact that the use of higher temperatures increases the capacity of solvents to solubilize analytes. For example, the solubility of anthracene

increases nearly 13-fold as we increase temperature from 50 to 150 °C. Increasing the temperature also leads to faster diffusion rates. This means that analytes move faster from the boundary layer near the surface of the matrix from which they are extracted to the bulk solvent at higher temperatures. Higher temperatures also mean lower solvent viscosities, meaning that the solvent can penetrate the pores of the matrix more easily. Finally, increased temperature makes it easier to disrupt solute-matrix interactions (dipole attractions, van der Waals forces, hydrogen bonding, etc.) and remove analytes from the matrix. Taken all together, the net effect is that doing extractions at elevated temperatures means that the extractions happen much faster and use less solvent. However, temperature alone is not enough because many of the organic solvents used in extractions boil at relatively low temperatures. This is one limitation of techniques such as Soxhlet or automated Soxhlet. The highest temperature at which extractions take place in these techniques is the boiling point of the solvent.

If sufficient pressure is exerted on the solvent during the extractions, temperatures above the boiling point can be used. This means that all of the advantages of working at elevated temperature can be realized even with solvents with relatively low boiling points. Operating at elevated pressures also helps the overall extraction process to happen more quickly. Pumping solvent through a packed bed is easier at elevated pressures. Pressurized solvent will be forced into the pores of the sample matrix, coming in more intimate contact with analytes in those areas. Hence, the combination of elevated temperatures and pressures allows extractions to occur rapidly and completely. For a more detailed discussion of the theoretical consideration of ASE, consult Richter et al., *Anal. Chem.* **1996**, *68*, 1033-1039.

E.2 Operation

ASE was first described in 1995 and 1996 (1–9). As a technique, it has grown steadily in use since that time. [Figure E-1](#) shows a schematic of accelerated solvent extraction.

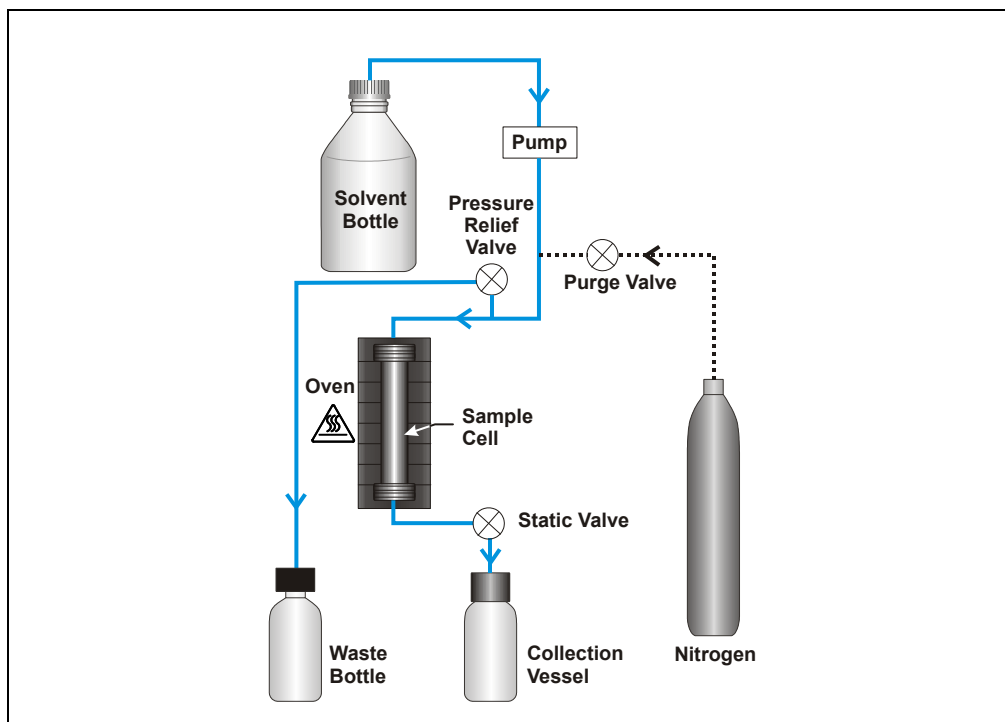

Figure E-1. Schematic of the ASE Process

To perform an extraction, the solid sample is loaded into a sample cell (1 to 100 mL), and the frit-containing end caps are tightened by hand onto the cells. The filled sample cells are loaded into the oven for extraction and a collection vessel (bottle or vial) is installed in the collection vessel holder. The oven is maintained at the chosen operating temperature throughout the extraction (room temperature to 200 °C). The cell design and associated fluid apparatus allow operation of the extractions at elevated pressures (up to 1500 psi) to maintain the solvents as liquids at temperatures above their boiling points. The temperature and pressure are controlled independently for each cell regardless of the solvent used, the moisture or mineral content of the sample, or any characteristic of the matrix

that might affect the actual extraction temperature. This is an advantage when compared to microwave extraction, in which the actual pressure and temperature of the extraction will be influenced strongly by the above mentioned sample parameters.

Once the cell is in place in the oven, the pump immediately begins to deliver the solvent of choice to the sample cell. Once solvent has made its way through the sample cell and reaches the collection vessel, the static valve closes to allow pressurization of the cell. Since the solvent expands as it heats, the pressure in the cell will increase when the static valve closes. When the pressure reaches 200 psi above the set point, the static valve rapidly opens to relieve the pressure and then closes again. The pump also delivers fresh solvent to the cell in an effort to return the pressure to the set point value. This addition of fresh solvent during ASE is analogous to fresh solvent dripping down from the condenser onto the extraction thimble during Soxhlet extraction.

The first phase of the run is called the heat-up time, as the cell contents are heated by the oven to the chosen operating temperature. Heat-up times vary between 5 minutes for 100 °C and 9 minutes for 200 °C. After the heat-up time, the extraction enters a static period with a duration chosen by the user. Typical static times are 5 minutes, but can vary from 0 to 99 minutes. After the static time, fresh solvent is pumped through the cell to remove extracted analytes while the sample and solvent are still hot. The amount used for the rinse can vary from 0% to 150% of the volume of the cell used for the extraction (40% to 60% is most common). The user can choose the number of times the sample will be in the static mode, and this is entered as the number of static cycles. The rinse volume is divided by the number of static cycles so that fresh solvent is present at the beginning of each static cycle. In other words, if one static cycle is chosen, the entire rinse volume will be pumped through the cell at the end of the static time. If three static cycles are chosen, a third of the total rinse volume will be pumped through the cell at the conclusion of each static cycle. The number of static cycles can be programmed from one to five with one cycle being the most common. Following the final solvent rinse, solvent is purged out of the cell using nitrogen at 150 psi for a predetermined period of time. The total time for the extraction is usually less than 15 minutes, and the amount of solvent used is approximately 1.5 times the volume of the sample cell (for example, about 15 mL for the 10-mL cell). The extracts are delivered to the collection vessels through a filter, and in many cases do not need any additional preparation prior to analysis. Since the extract is diluted by the total volume of extraction solvent plus the rinse solvent, sometimes a further concentration step is required (i.e., evaporation, solid-phase extraction, etc.) when performing trace analysis.

Upon completion of the purge step, the cell can be removed from the oven and the next extraction can be started.

Many features are in place to minimize safety issues with using solvents at elevated temperatures and pressures. Flammable vapor sensors, liquid leak detectors, checks for collection vessel overflow conditions, three levels of overpressurization prevention (electronic and mechanical), solvent flow monitoring, and pneumatic source pressure monitoring are among the safety measures in place on ASE instrumentation.

E.3 Method Optimization

Method optimization consists of two main parts: sample preparation (prior to extraction) and extraction parameters.

E.3.1 Sample Preparation

Sample preparation is an essential part of every solvent-based extraction procedure. While many sample types can be efficiently extracted without any pretreatment, other samples will require some manipulation for an efficient extraction to occur. In general, the same sample preparation that is done prior to Soxhlet or sonication extraction should be done prior to extraction by ASE. This section discusses three sample preparation techniques: grinding, dispersing, and drying.

Grinding

For an efficient extraction to occur, the solvent must make contact with the target analytes. The more surface area that can be exposed in a sample, the faster an extraction will occur. Samples with large particle sizes should be ground prior to extraction. Efficient extraction requires a minimum particle size, generally smaller than 1 mm. Grinding can be accomplished with a conventional mortar and pestle or with electric grinders and mills. Often a large, representative sample can be ground and weighed portions of the ground sample can be used for extraction. Soil and sediment samples generally do not need to be ground, although it may be necessary to remove stones or sticks from the samples prior to extraction. Polymer samples must be in a ground state for an efficient extraction of additive compounds. Materials such as polymers and rubbers are best ground at reduced temperatures (e.g., liquid nitrogen).

Animal or plant tissue samples can be homogenized using any procedure, such as a blender or tissue homogenizer. Soil samples do not need to be ground before extraction.

The effects of sample surface area on extraction efficiency have been studied. Three samples of mozzarella cheese were prepared differently and extracted for fat content using ASE. The chopped samples were cut into pieces ranging in size between 2 and 5 mm. The ground samples were ground with diatomaceous earth (1:2). Each sample was extracted with a mixture of hexane:2-propanol (3:2) using the following ASE conditions: 1000 psi, 125 °C, 6 min heat-up, 3 x 10 min static cycle, 100% rinse, 60 s purge, and one 11-mL cell containing one cellulose filter. The extracts were analyzed gravimetrically. The ASE results were compared to results obtained from Mojonnier extraction. These results (shown in [Figure E-4](#)) demonstrate that increasing the surface area by grinding the sample results in higher extraction efficiencies.

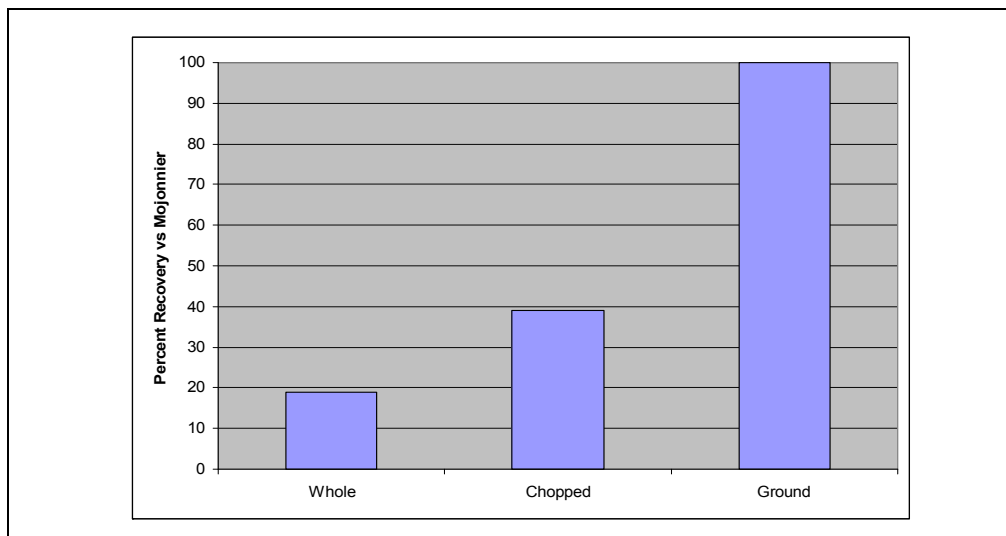

Figure E-2. Effect of Sample Particle Size for ASE vs. Mojonnier Extraction. Whole cheese (0.5 to 1.5 cm size); chopped (2-5 mm); ground (mixed thoroughly with diatomaceous earth)

Dispersing

The aggregation of sample particles may prevent efficient extraction. In these cases, dispersing the sample with an inert material such as sand or diatomaceous earth will assist in the extraction process. Dispersing is also recommended with samples that tend to compact in the sample cell outlet. These samples normally contain very small particles that can adhere tightly to each other when under pressure. It is important to periodically run blank extractions of the dispersing agent to verify its cleanliness. Some samples may compact in the sample cell due to the high pressures used in ASE. In these cases, mixing the sample with sand or diatomaceous earth will prevent this compacting of the sample that can lead to occlusion of the sample cell. When extracting soil or sediment samples, it is important to mix the samples with a dispersing agent unless the samples are completely dry. If the soil or sediment samples are wet or high in clay, the samples can be mixed with either sand or diatomaceous earth, but the latter is preferred because it will adsorb some of the water and make the sample easier to handle.

Drying

Samples do not have to be completely dry to achieve efficient extractions with ASE. This depends on the analytes and the solvent used for extraction. High levels of water can prevent nonpolar organic solvents from reaching the target analytes. The use of more polar solvents (for example, acetone and methanol) or solvent mixtures (for example, hexane/acetone and methylene chloride/acetone) can assist in the extraction of wet samples. Elevated temperatures can also improve the extraction efficiency of wet samples (10). In addition, the solvent being used will impact the type of drying that needs to be done to a sample and whether it need to be done at all. With nonpolar solvents, the need for drying is more important. One can also use a bridge solvent such as acetone (for example, hexane/acetone, 1:1) mixed with a nonpolar solvent to improve the extraction efficiency of wet samples.

Sample drying prior to extraction is an efficient way to handle wet samples. Drying can be accomplished by direct addition of a drying agent such as diatomaceous earth. The use of magnesium sulfate is not recommended with ASE due to the extremely hard, concrete-like material that can be produced. Sodium sulfate should be used **only** with nonpolar solvents (hexane, heptane, toluene, etc.). Sodium sulfate can become

soluble in the extraction process and then be deposited in the exit lines. Oven drying and freeze drying are other viable alternatives for sample drying prior to extraction; however, the recovery of volatile compounds may be compromised by these procedures.

The sample drying or dispersing agent should be mixed thoroughly with the sample in a small vial, beaker, or mortar, and then added to the sample cell. For quantitative transfer, the mixing vessel can be rinsed with 1 to 2 mL of the extraction solvent using a Pasteur pipette, and this volume added directly to the sample cell. The main purpose of mixing with a drying agent like diatomaceous earth is not to remove all water from the sample but to make it easy to transfer the sample into the sample cell. If elevated temperatures are used, then some water will be removed from the sample during the extraction process. In this case, sodium sulfate can be added to the extract after collection to remove water.

E.3.2 Extraction Parameters

Solvent

For an efficient extraction, the solvent must be able to solubilize the target analytes while leaving the sample matrix intact. The polarity of the extraction solvent should closely match that of the target compounds. The common adage of “like dissolves like” is very applicable in ASE. Mixing solvents of differing polarities can be used to extract a broad range of compound classes. Generally, if a particular solvent has been shown to work well in a conventional procedure, it will also work well in ASE. Compatibility with the postextraction analytical technique, the need for extract concentration (solvent volatility), and the cost of the solvent should all be considered. While many ASE methods recommend solvents or solvent mixtures for specific analyte classes, there may be alternatives that better fit the needs of a particular laboratory. For example, Schantz (11) showed that dichloromethane/acetone or acetonitrile can be used to get complete extraction of polycyclic aromatic compounds. If GC or GC-MS is the analytical method, then dichloromethane/acetone would be the solvent of choice. If HPLC is the determinative step, then acetonitrile would be the solvent of choice. Solvent choice will also determine the level of coextractables along with the analytes. Generally, the more polar the solvent or solvent mixture, the less selective it will be.

Solvents that exhibit marginal results at ambient conditions may perform adequately under ASE conditions. Most liquid solvents, including water and buffered aqueous mixtures, can be used in ASE. Strong acids (HCl, HNO₃, H₂SO₄) are not recommended for use with stainless steel cells because they may damage the cells. Small amounts of these acids can be used with zirconium cells **only**. When required, weak acids such as acetic or phosphoric can be used. These should be added to aqueous or polar solvents in the 1-10% (v/v) range.

For extraction of polymer samples, select a solvent that will extract the additives but not the matrix itself. For example, isopropanol with small levels of cyclohexane has been shown to work well for the extraction of phenolic antioxidant additives in polymers.

Temperature

Temperature is the most important parameter used in ASE extraction. As the temperature is increased, the viscosity of the solvent is reduced, thereby increasing its ability to wet the matrix and solubilize the target analytes. The added thermal energy also assists in breaking analyte-matrix bonds and encourages analyte diffusion from the matrix surface. When developing a new method, start at 100 °C, or if the target analytes have a known thermal degradation point, start at 20 °C below this level. Most ASE applications operate in the 75 to 125 °C range, with 100 °C the most common temperature for environmental applications. If the sample has a tendency to melt in the sample cell, a cellulose thimble can be used to facilitate extraction and sample removal. An example of the effect of temperature is shown below for the extraction of petroleum hydrocarbons (TPH) from soil. Note that not only does the analyte recovery increase, but the reproducibility improves as a function of temperature.

Temperature	Recovery	RSD (%)
27 °C	81.2	6.0
50 °C	93.2	5.0
75 °C	99.2	2.0
100 °C	102.7	1.0

Samples were analyzed by IR, with n = 5.

Table E-1. Effect of Temperature on TPH; Extraction from Soil

There appears to be confusion about the purpose of the preheat function available on ASE systems. When this is used, a cell is placed in the oven and heated without any solvent being pumped into the cell. This function was originally developed to allow pre-extraction derivatization of analytes or the drying of samples by blowing nitrogen through the cell while it is heated. The preheat function should **not** be used in routine ASE operation. In general, this should always be set to zero minutes. If used, recoveries of more volatile compounds (for example, organochlorine pesticides) will be greatly reduced.

Pressure

The effect of pressure is to maintain the solvents as liquids while above their atmospheric boiling points, and to rapidly move the fluids through the system. The pressures used in ASE are well above the thresholds required to maintain the solvents in their liquid states, so pressure adjustments for changing solvents are not required. Changing the pressure will have very little impact on analyte recovery, and it is not considered a critical experimental parameter. ASE extractions are performed at 1500 psi (10 MPa).

Cycles

The use of static cycles was developed to introduce fresh solvent during the extraction process, which helps to maintain a favorable extraction equilibrium. This effectively approximates dynamic extraction conditions without the need for troublesome flow restrictors to maintain pressure. When more than one cycle is used in a method, the rinse volume is divided by that number. When the first static time is complete, the divided portion of the rinse volume is delivered to the cell, with the “used” solvent directed to the collection vessel. The system then holds the sample and solvent for a second static period. The nitrogen purge step is initiated only after the final static cycle. Because the original rinse volume has only been divided, no additional solvent is used for the extraction. Static cycles have proven to be useful for sample types with a very high concentration of analyte, or samples with difficult to penetrate matrices. The static time can be adjusted to minimize the total extraction time. For example, three 3-min static cycles can be used in place of one 10-min static step. When low temperature extractions are desired (< 75 °C), multiple static cycles should be used to compensate for the

smaller amount of solvent being introduced during the heat-up step, as the static valve pulses to regulate the pressure.

Time

Certain sample matrices can retain analytes within pores or other structures. Increasing the static time at elevated temperatures can allow these compounds to diffuse into the extraction solvent. The effect of static time should always be explored in conjunction with static cycles, in order to produce a complete extraction in the most efficient way possible.

Generally, ASE extractions are completed in less than 20 minutes, and if times longer than this are necessary to get complete extraction, then a higher temperature, different solvent, or multiple static cycles should be explored to reduce the overall extraction time.

E.4 Method Development

A representative sample should be prepared as outlined in the discussion above on sample preparation. Select the sample cell size that most closely matches the sample size. The sample cells do not need to be filled completely; however, a full cell will use less solvent in the extraction process than a partially filled one. A recommended set of conditions to begin method development are as follows: pressure=1500 psi (10 MPa), temperature=100 °C (or 20 °C below analyte decomposition temperature), static time=5 min, rinse volume=40%, purge time=60 s (up to 300 s for 100-mL cell), and static cycle=1. If desired, a sequence can be created to extract each of a series of samples by a different set of conditions and collected in separate collection vessels. Samples can also be extracted multiple times to determine extraction completeness. If analyte is present in the second or third vessel, then the initial conditions need to be changed.

The order of change would be (1) change the solvent, (2) increase the temperature, (3) add a second or third cycle, and (4) increase the time. In this way, one can quickly determine the optimized extraction conditions for a particular analyte and matrix.

E.5 Selectivity in ASE

Selectivity in extraction is defined here as being able to extract compounds of interest with little or no interfering coextracted compounds. ASE is generally considered to be an exhaustive extraction technique, and often the extracts obtained from complex samples contain compounds that can interfere with the determination of the desired analytes. Selectivity in ASE could come from the manipulation of the extraction conditions to minimize coextractables while maximizing analyte recovery. There are three basic procedures to obtain selective extraction in ASE or, in other words, to generate extracts that contain the compounds of interest and few, if any, interfering compounds. The three techniques are choice of temperature, choice of solvent, and use of adsorbents in the sample cell. Of course, the most powerful method is to use variations of all three to fine-tune the selectivity during the ASE process.

The choice of temperature alone can affect selectivity. The higher the temperature for the extraction, the less selective the results. Lowering the temperature will make ASE more selective, but the recovery of analytes can diminish unless the time is increased. Similarly, selectivity is decreased when using more polar solvents. However, one can use a series of solvents of increasing polarity to obtain selective extractions or what could be called fractionation.

Dark-colored fruits such as blueberries are being studied for their antioxidant content. These compounds are polyphenolic in nature and require polar solvents for extraction. However, if the fruit sample is extracted with a polar solvent like methanol, acetonitrile, ethanol, or water, the resulting extract contains many compounds that make the analysis for antioxidant compounds more challenging. We have found that the samples can first be extracted with nonpolar solvents like hexane or DCM to remove unwanted wax compounds. Then, by extracting the same sample with solvents of increasing polarity and collecting the fractions in separate vessels, one can obtain extracts that are easier to analyze.

[Figure E-3](#) is a photo of extracts obtained from a single sample of wild blueberries extracted with hexane, followed by DCM, ethyl acetate, acetonitrile, and then ethanol. Clearly, using a fractionation procedure like this can offer advantages when analyzing extracts of plant materials that can contain several hundred compounds of interest.

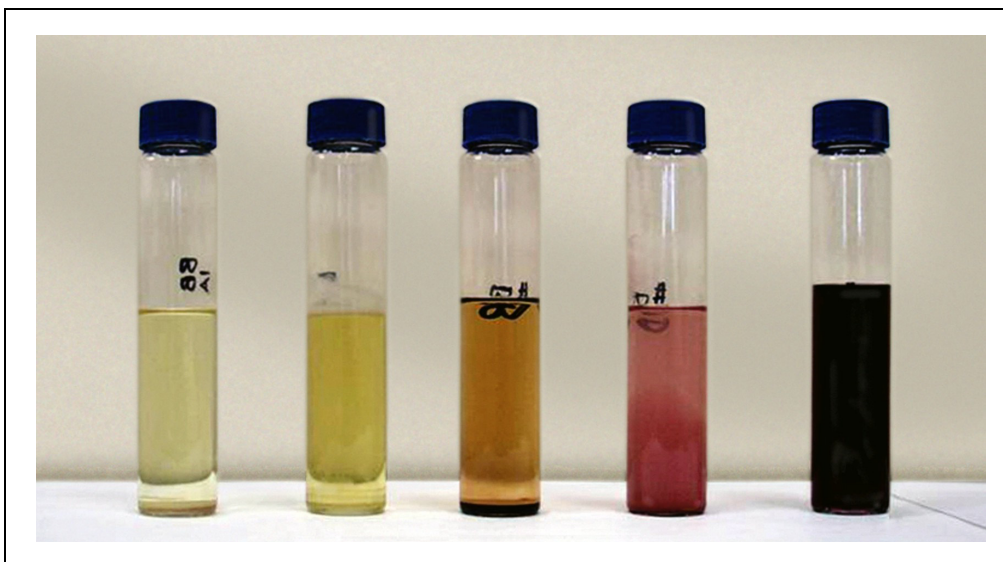

Figure E-3. Selectivity in ASE. The same sample of blueberries was extracted with hexane (most left), DCM, ethyl acetate, acetonitrile, and ethanol

Another unique use of solvent selectivity was reported by Draisci et al. (12). The authors reported the use of ASE for the extraction of corticosteroids from beef liver prior to analytical determination by LC-MS. First, the sample was extracted with hexane to remove the majority of lipids that would interfere in the determinative step. Next, the samples were extracted with hexane/ethyl acetate to remove the steroid compounds. Solvent fractionation using ASE is an area that needs to be explored to more fully understand its potential.

The use of sorbents in the sample cell along with the sample has offered some of the highest level of selectivity in ASE. Typically, the adsorbent is loaded into the sample cell first (outlet end) and the sample is loaded on top of the adsorbent. This way, the flow of the solvent during the extraction is such that unwanted compounds will be retained in the cell by the adsorbent. Azalea et al. (13) first reported the use of alumina in sample cells to retain lipids when extracting PCBs

from fish tissue using ASE. They reported that, as the temperature of the extraction rises or as the polarity of the solvent increases, the capacity of the alumina to retain lipids decreases. For example, if hexane or heptane is the extraction solvent, heat-activated alumina will retain about 70 mg of lipid per gram of alumina. If DCM is used, then the capacity is only about 35 mg of lipid per gram of alumina. If the correct amount of sorbent is used, then extracts can be produced using ASE that require no additional post-extraction treatment other than volume adjustment.

The most common use of adsorbents in ASE has been for the extraction and determination of nonpolar compounds such as PCBs, OCPs, PCDDs, and PCDFs in high lipid content matrices such as food or animal tissue. Other adsorbents that have been used include copper, C18 resin, Florisil, silica gel, acid-impregnated silica gel, and ion-exchange resins. [Table E-2](#) shows a summary with related references.

Adsorbent	Uses	Reference
Silica	Removes nonpolar lipids	4
Florisil	Removes nonpolar lipids	15, 16
Alumina	Removes nonpolar lipids and colored compounds	13, 17, 18
C18 resin	Removes nonpolar lipids	19, 20
Ion-exchange resins	Removes ionic interferences	22
Copper powder	Removes sulfur	11, 23
Carbon	Assists with purification of PCDDs, PCDFs, and coplanar PCBs	24, 25

Table E-2. List of Adsorbents Used in ASE

There are a few interesting things to note from this table. Acid-impregnated silica gel has the highest capacity for lipid retention of all the adsorbents that have been reported. It has roughly double the capacity of alumina. The sulfuric acid is typically present on the silica at 40% (wt/wt). Copper powder (cleaned with HCl first) can be used to retain sulfur when extracting sediment samples.

An interesting use of a C18 adsorbent was reported by Gentili and colleagues (21). In this case, they were extracting polar antibiotics (sulfonamides) from animal tissues. They put C18 material in the outlet of the cell to retain some of the

lipids that extracted with the analytes. Then the samples were placed in a freezer to allow them to separate and harden. The samples were centrifuged and aliquots were removed and analyzed. This is a case in which the analytes were polar, the solvent was polar (water), and the matrices (baby food and meat) were polar. This is in contrast to several publications in which the analytes were relatively nonpolar (PCBs, PCDDs, OCPs, etc.) and the solvents were nonpolar (like hexane). In this case, the adsorbents have higher capacity than in the case where the extraction solvent is polar.

Ion-exchange resins can be used to remove unwanted ionic species (22). For example, Thermo Fisher Scientific has been involved in projects to determine perchlorate in soils and vegetation samples. Water at 80 °C was used as the extraction solvent. Alumina was used to remove colored compounds such as chlorophyll. Ion-exchange resins were placed in the ASE cells that removed chloride and sulfate. This allowed the determination of perchlorate at the sub-ppb levels.

Björklund and his coworkers have published many articles on the use of adsorbents in-line in ASE cells to improve selectivity (25–31), especially for PCB and PCDD analysis. One article discusses the results of the development of a scheme that allows the separation of non-ortho PCBs and PCDD/Fs from the bulk of the PCBs, gravimetric fat determinations, and minimum post-extraction clean-up prior to analysis (25). This can be an obvious savings in time, labor, and solvent costs as compared to traditional extraction procedures followed by clean-up methods such as GPC.

ASE has been shown to work well for the extraction of acrylamide from many food matrices (32). The use of adsorbents in the ASE cell has now been extended to this application (33). Florisil was added to the cell when extracting coffee or chocolate samples. The authors report that 6 g of Florisil in the cell, along with 2 g of sample, produced clear extracts without any interferences. [Figure E-4](#) shows the effect of varying the level of the Florisil.

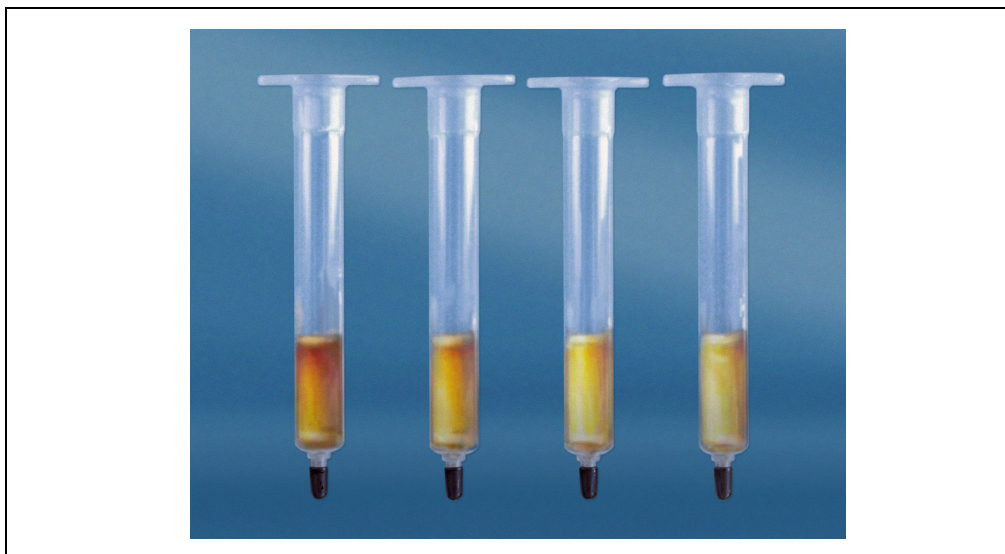

Figure E-4. Residual co-extractives after the ASE extraction of a coffee sample trapped on an SPE cartridge, the ASE cells containing from 0 to 6 g Florisil. From left to right: 1) No Florisil in the ASE cell, 2) 2 g Florisil in the ASE cell, 3) 4 g Florisil in the ASE cell, and 4) 6 g Florisil in the ASE cell.

One of the most fascinating uses of selective extraction with ASE was reported by Poerschmann et al. (34, 35). In this work, a combination of adsorbents in the cells, varying temperature, and solvent allowed fractionation to be achieved that was superior to conventional SPE after exhaustive extraction. This work demonstrated the fractionation of lipid classes using sequential extractions. Unmodified silica and cyanopropyl silica were used as the adsorbents in the outlet of the cells. The biological samples were extracted with hexane/acetone (9:1, v/v) at 50 °C to remove the neutral lipids. Then, the same samples were extracted with chloroform/methanol (1:4, v/v) at 110 °C to remove polar lipids such as phospholipids and hydroxy-containing fatty acids. What was intriguing about this work was that the authors demonstrated that this fractionation scheme could be

used to screen for diagnostic central nervous system (CNS) lipid markers in meat products. This is of particular interest for risk assessments studies for bovine spongiform encephalopathy (BSE) and food labeling legislation. The ASE fractionation scheme worked better than the widely used exhaustive lipid extraction procedure followed by SPE with regard to lipid recoveries and clean fractionation of the lipid classes. Clearly, the combination of temperature, solvent, and adsorbent materials in the ASE cell can provide unique selectivity and capability and provide additional advantages over other sample preparation techniques.

E.6 References

1. B. E. Richter, J. L. Ezzell, D. Felix, K. A. Roberts, and D. W. Later, "An Accelerated Solvent Extraction System for the Rapid Preparation of Environmental Organic Compounds in Soil," *American Laboratory* **27(4)**, 24-28 (1995).
2. F. Höfler, J. Ezzell, and B. Richter, "Beschleunigte Lösemittelextraktion (ASE), Teil 1," *LaborPraxis* **19(3)**, 62-67 (1995).
3. F. Höfler, J. Ezzell, and B. Richter, "Anwendungen der ASE in der Umweltanalytik" *LaborPraxis* **19(4)**, 58-62 (1995).
4. J. L. Ezzell, B. E. Richter, W. D. Felix, S. R. Black, and J. E. Meikle, "A Comparison of Accelerated Solvent Extraction with Conventional Solvent Extraction for Organophosphorus Pesticides and Herbicides," *LC/GC* **13**, 390-398 (1995).
5. B. E. Richter, J. L. Ezzell, D. Felix, K. A. Roberts, and D. W. Later, "An Accelerated Solvent Extraction System for the Rapid Preparation of Environmental Organic Compounds in Soil," *International Laboratory* **25(4)**, 18-20 (1995).
6. F. Höfler, D. Jensen, J. Ezzell, and B. E. Richter, "Accelerated Solvent Extraction of PAH from Solid Samples with Subsequent HPLC Analysis," *Chromatographie* **15**, 68-71 (Jan 1995).
7. J. L. Ezzell and B. E. Richter, "Automated Sample Preparation for Environmental Laboratories Using Accelerated Solvent Extraction," *American Environmental Laboratory* **8(2)**, 16-18 (1996).

8. B. E. Richter, B. A. Jones, J. L. Ezzell, N. L. Porter, N. Avdalovic, and C. Pohl, "Accelerated Solvent Extraction: A Technique for Sample Preparation," *Anal. Chem.* **68**, 1033-1039 (1996).
9. D. Jensen, F. Höfler, J. Ezzell, and B. Richter, "Rapid Preparation of Environmental Samples by Accelerated Solvent Extraction (ASE)," *Polycyclic Aromatic Compounds* **9**, 233-240 (1996).
10. B. E. Richter, "Extraction of Hydrocarbon Contamination from Soils Using Accelerated Solvent Extraction," *J. Chromatogr. A*, **874(2)**, 217-224 (2000).
11. M. M. Schantz, J. J. Nichols, and S. A. Wise, "Evaluation of Pressurized Fluid Extraction for the Extraction of Environmental Matrix Reference Materials," *Anal. Chem.* **69**, 4210-4219 (1997).
12. R. Draisci, C. Marchiafava, L. Palleschi, P. Cammarata, and S. Cavalli, "Accelerated Solvent Extraction and Liquid Chromatography-Tandem Mass Spectrometry Quantitation of Corticosteroid Residues in Bovine Liver," *J. Chromatogr., B.: Anal. Technol. Biomed. Life Sci.* **753**, 217-223 (2001).
13. J. Ezzell, B. Richter, and E. Francis, "Selective Extraction of Polychlorinated Biphenyls from Fish Tissue Using Accelerated Solvent Extraction," *American Environmental Laboratory*, **8(12)**, 12-13 (1996).
14. J. L. Gomez-Ariza, T. Garcia-Barrera, F. Lorenzo, and A. Gustavo Gonzales, "Optimisation of a Pressurised Liquid Extraction Method for Haloanisoles in Cork Stoppers," *Anal. Chim. Acta*, **540**, 17-24 (2005).
15. J. L. Gomez-Ariza, M. Bujalance, I. Giraldez, A. Velasco, and E. Morales, "Determination of Polychlorinated Biphenyls in Biota Samples Using Simultaneous Pressurized Liquid Extraction and Purification," *J. Chromatogr., A.*, **946**, 209-219 (2002).
16. U.S. EPA Method 3620C, Florisil Cleanup. U.S. Environmental Protection Agency, Cincinnati, OH, 2000.
17. Thermo Fisher Scientific, "Selective Extraction of PCBs from Fish Tissue Using Accelerated Solvent Extraction (ASE)," Application Note 322, LPN 0764, Sunnyvale, CA, 1996.
18. Thermo Fisher Scientific, "Determination of PCBs in Large-Volume Fish Tissue Samples Using Accelerated Solvent Extraction (ASE)," Application Note 342, LPN 1204, Sunnyvale, CA, 2000.

19. E. Björklund, A. Muller, and C. von Holst, "Comparison of Fat Retainers in Accelerated Solvent Extraction for the Selective Extraction of PCBs from Fat-Containing Samples," *Anal. Chem.*, **73**, 4050-4053 (2001).
20. S. Sporning and E. Björklund, "Selective Pressurized Liquid Extraction of Polychlorinated Biphenyls from Fat-Containing Food and Feed Samples: Influence of Cell Dimensions, Solvent Type, Temperature and Flush Volume," *J. Chromatogr., A.*, **1040**, 155-161 (2004).
21. A. Gentili, D. Perret, S. Marchese, M. Sergi, C. Olmi, and R. Curini, "Accelerated Solvent Extraction and Confirmatory Analysis of Sulfonamide Residues in Raw Meat and Infant Foods by Liquid Chromatography Electropray Tandem Mass Spectrometry," *J. Agric. Food Chem.*, **52**, 4614-4624 (2004).
22. Thermo Fisher Scientific, "Determination of Perchlorate in Vegetation Samples Using Accelerated Solvent Extraction (ASE) and Ion Chromatography," Application Note 356, LPN 1830, Sunnyvale, CA, 2006.
23. U.S. EPA Method 3660B, Sulfur Cleanup. U.S. Environmental Protection Agency, Cincinnati, OH, 1996.
24. M. Nording, S. Sporning, K. Wiberg, E. Björklund, and P. Haglund, "Monitoring Dioxins in Food and Feedstuffs Using Accelerated Solvent Extraction with a Novel Integrated Carbon Fractionation Cell in Combination with CAFLUX Bioassay," *Anal. Bioanal. Chem.*, **381**, 1472-1475 (2005).
25. P. Haglund, S. Sporning, K. Wiberg, and E. Björklund, "Shape-Selective Extraction of PCBs and Dioxins from Fish and Fish Oil Using In-Cell Carbon Fractionation Pressurized Liquid Extraction," *Anal. Chem.*, **79**, 2945-2951 (2007).
26. E. Björklund, S. Sporning, K. Wiberg, P. Haglund, and C. von Holst, "New Strategies for Extraction and Clean-up of Persistent Organic Pollutants from Food and Feed Samples Using Selective Pressurized Liquid Extraction," *Trends in Anal. Chem.*, **25(4)**, 318-325 (2006).
27. A. Hussen, R. Westbom, N. Megersa, N. Retta, L. Mathiasson, and E. Björklund, "Optimisation of Pressurized Liquid Extraction for the Determination of p,p'-DDT and p,p'-DDE in Aged Contaminated Ethiopian Soils," *Anal. Bioanal. Chem.*, **386(5)**, 1525-1533 (2006).
28. A. Hussen, R. Westbom, N. Megersa, L. Mathiasson, and E. Björklund, "Development of a Pressurized Liquid Extraction and Clean-up Procedure for

- the Determination of α -endosulfan, β -endosulfan and endosulfan sulfate in Aged Contaminated Ethiopian Soils,” *J. Chromatogr. A*, **1103**, 202-210 (2006).
29. S. Sporning, C. von Holst and E. Björklund, “Selective Pressurized Liquid Extraction of PCB's from Food and Feed Samples: Effects of High Lipid Amounts and Lipid Type on Fat Retention,” *Chromatographia*, **64(9-10)**, 553-557 (2006).
 30. K. Wiberg, S. Sporning, P. Haglund, and E. Björklund, “Selective Pressurized Liquid Extraction of Polychlorinated Dibenzo-p-dioxins, dibenzofurans and dioxin-like polychlorinated biphenyls from Food and Feed Samples,” *J. Chromatogr. A*, **1138**, 55-64 (2007).
 31. A. Hussien, R. Westbom, N. Megersa, L. Mathiasson, and E. Björklund, “Selective Pressurized Liquid Extraction for Multi-residue Analysis of Organochlorine Pesticides in Soil,” *J. Chromatogr. A*, **1152**, 247-253 (2007).
 32. Thermo Fisher Scientific, “Fast Determination of Acrylamide in Food Samples Using Accelerated Solvent Extraction (ASE) Followed by Ion Chromatography with UV or MS Detection,” Application Note 409, LPN 1497, Sunnyvale, CA, 2003.
 33. Thermo Fisher Scientific, “Extraction and Cleanup of Acrylamide in Complex Matrices Using Accelerated Solvent Extraction (ASE) Followed by Liquid Chromatography, Tandem Mass Spectrometry (LC-MS/MS),” Application Note 358, LPN 1922, Sunnyvale, CA, 2007.
 34. J. Poerschmann and R. Carlson, “New Fractionation Scheme for Lipid Classes Based on ‘In-Cell Fractionation’ Using Sequential Pressurized Liquid Extraction,” *J. Chromatogr. A*, **1127**, 18-25 (2006).
 35. J. Poerschmann, U. Trommler, W. Biedermann, U. Truyen, and E. Lucker, “Sequential Pressurized Liquid Extraction to Determine Brain-Originating Fatty Acids in Meat Products as Markers in Bovine Spongiform Encephalopathy Risk Assessment Studies,” *J. Chromatogr. A*, **1127**, 26-33 (2006).

A

- Abort screen, 47
- Aborting a run, 10, 47
- Acetone, 28, 55
- Acidic solvents
 - Shutdown procedure, 55
- Adapter for collection vials, 13
- Air in solvent lines, 48
- Arrow buttons, 11
- ASE 150
 - Control panel, 9
 - Dimensions, 106
 - Display screen, 9
 - Front panel controls, 9
 - Illustration, 7
 - Installation, 109 – 124
 - Lifting safely, 109
 - Maintenance, 54 – 55
 - Moduleware version, 137
 - Operating humidity, 105
 - Operating temperature, 105
 - Overview, 1 – 2
 - Safety diagnostics, 2
 - Safety standards, 3 – 4
 - Serial number, 15
 - Ship Kit, 14, 110
 - Spare parts, 139
 - Startup Kits, 110
 - Weight, 106, 109
- ASE Prep CR, 27, 142
- Autoignition point of solvents, 25
- AutoSeal
 - Function, 8
 - Inspecting tips for damage, 55
 - Location, 8
 - Pressure when actuated, 114, 135

B

- Basic solvents
 - Shutdown procedure, 55
- Blueberry extracts, 155
- BNA method parameters, 20
- Bottle sensor, 134
- Bottle, collection *See* Collection vessel
- Bottle, solvent, 8, 14
 - See also* Solvent reservoir
- Buttons, front panel, 10 – 11

C

- Cap
 - Collection vessel, 13
 - Solvent reservoir, 14, 29, 115
 - Waste bottle, 14, 41, 117
 - See also* Cell end caps
- Caution icon, 3
- Cell door
 - How to open, 8
- Cell end caps
 - Cleaning, 46
 - Frit, 11, 34
 - Installing a filter, 34 – 35
 - O-ring replacement, 38
 - O-rings, 38
 - Seal replacement, 69, 71 – 72
 - Snap ring, 70 – 71
- Cell filters, 34 – 36
 - Cellulose, 34
 - Glass-fiber, 34
 - Insertion tool, 36
 - Installing, 34 – 36
 - Part numbers, 140
 - Size selection, 34
 - Type selection, 34

Cell holder, 8
 Moving the lower latch, 118
Cell sensor, 134
Cells *See* Sample cells
Cellulose cell filters, 34
 Part numbers, 140
 See also Cell filters
Check valves, 77
 Cleaning procedure, 78
 Replacement procedure, 76 – 79
Cheese
 Extracting for fat content, 148
Clamp plate
 Temperature too high, 62
 Temperature too low, 61
Coffee extracts, 158
Collection bottle *See* Collection vessel
Collection vessel, 8, 13
 Adapter for 60-mL vials, 13
 Caps, 13
 Graduated, 13
 Overfilling, 53, 59
 Part numbers, 141
 Septum, 13
 Types available, 13
Collection vessel specifications, 106
Completing the run, 45
Connectors
 Rear panel, 15
Contacting Thermo Fisher Scientific, 69
Control panel, 9
 Illustration, 9
Converter, analog-to-digital, 60
Cooling rack, 45, 49, 125
Creating a method, 49 – 53
Cursor
 Blinking, 9
 Moving, 11
Cursor arrow buttons, 11
Custom methods (1 through 24)
 Editing, 49 – 52
 Parameters, 49, 131

D

Daily maintenance, 54
Danger icon, 3
Degassing solvents, 26
Diagnostics, 2
Diagnostics screen, 133
 Displaying, 133
Diatomaceous earth (DE), 31 – 32, 142
Dimensions of ASE 150, 106
Dispersing agents, 31
Dispersing sample, 149
Display and keypad specifications, 106
Display screen, 9
 Viewing more lines of text, 51
Drip tray, 7 – 8, 74
Drying agents, 31
Drying samples, 149

E

Electrical cables, 67
Electrical specifications, 105
End-line filter, 29, 115
Environmental specifications, 105
Error messages, 2, 57
 Analog-to-digital converter failed, 60
 Cell not detected, 59
 Cell pressure threshold exceeded, 58
 Cell size wrong, 65
 Clamp plate temperature high, 62
 Clamp plate temperature low, 61
 Collection bottle full, 59
 Collection bottle not detected, 59
 Oven compression pressure low, 57
 Oven heater AC line voltage too high, 64
 Oven heater malfunction, 64
 Oven temperature high, 58
 Oven temperature low, 58
 Oven unable to reach temperature, 62
 Pump volume limit exceeded, 60
 Remove cell during oven wait period, 63
 Removing messages from the screen, 57

- Solvent vapor threshold exceeded, 61
 - System pressure low, 58
 - Top plate heater AC line voltage too high, 64
 - Top plate heater malfunction, 65
 - Unable to fill cell, 63
 - Unable to rinse, 62
- Extraction cells
- See* Sample cells
- Extraction Counters screen, 85, 99, 137
- Extractions
- Monitoring, 18
 - Overview of process, 17
 - Selectivity in, 154
 - Solvent selection, 26
 - Stopping, 47
 - See also* Running
- Extracts
- Processing, 46
- ## F
- Facilities required, 109
- FAT method parameters, 21
- Filter insertion tool, 36
- Part number, 140
- Filter, end-line, 29, 115
- Filters, cell, 34 – 36
- Installing, 34 – 36
 - Size selection, 34
 - Type selection, 34
- Filters, cellulose, 34
- Part number, 140
- Filters, glass-fiber, 34
- Part number, 140
- Fittings
- Gas leaks, 67
 - Liquid leaks, 65
 - Nitrogen, 110
 - Replacing, 69
 - Solvent reservoir, 29
 - Tightening, 69
- Flush
- See* Rinse cycle during a method
- Flush volume
- See* Rinse volume
- Frit, cell end cap, 11
- Stainless steel part number, 139
 - Zirconium part number, 140
- Front panel buttons, 11
- Funnels, 37
- Part numbers, 37, 140
- Fuses, 15, 105
- Part number, 142
 - Rating, 103, 142
 - Replacing, 103
- ## G
- Gas
- Connecting to the source, 110
 - Leaks, 67
 - Source requirements, 109
- Glass-fiber cell filters, 34
- Part numbers, 140
 - See also* Cell filters
- Gloves, thermal, 45, 118
- Graduated collection vessel, 13
- Grinding samples, 31, 33
- ## H
- Heater cable, 58, 61 – 62
- HRB method parameters, 21
- Humidity, operating, 105
- Hydrocarbon Sensor screen, 136
- ## I
- Important icon, 3
- Inlet check valve, 77
- Installation, 109 – 124
- Connecting the gas source, 110
 - Connecting the solvent reservoir, 115
 - Facilities required, 109

- Installing the waste bottle, 117
- Parts required, 110
- Rinsing the system, 122
- Starting the ASE 150, 114
- Interior components' specifications, 107

L

- Labels, safety, 5
- Leaks, gas, 67
- Leaks, liquid, 65 – 67
 - During static cycle, 67
- LEDs, front panel, 10
- Lifting the ASE 150, 109
- Liquid leaks, 65 – 67
 - During static cycle, 67

M

- Main PC board, 60, 67
- Maintenance, 54
 - Annual, 55
 - Daily, 54
 - Periodic, 54
- Menu button, 10
- Menu screen, 128
 - Displaying, 128
 - Selecting options, 128
- Method development, 52 – 53
 - Solvent selection, 26
- Method Editor screen, 131
- Methods, 19
 - Optimizing, 147
 - Sample cell size, 120, 130
 - Selecting a method to run, 120, 130
 - Stopping a running method, 47
- Methods, custom (1 through 24)
 - Editing, 49 – 52
 - Parameters, 49, 131
- Methods, preprogrammed, 20
 - Chlorinated herbicides (HRB), 20 – 21
 - Dioxins and furans (PDF), 20, 22

- Organochlorine pesticides (OCP), 20 – 21
- Organophosphorous pesticides (OPP), 20, 22
- Polychlorinated biphenyls (PCB), 20, 22
- Polymer additives (PPE), 20, 23
- Semivolatiles (BNA), 20
- Total fat (FAT), 20 – 21
- Total petroleum hydrocarbons (TPH), 20, 23

- Moduleware, 137
 - Version number, 137
- Mojonnier extraction, 148
- Mozzarella cheese
 - Extracting for fat content, 148

N

- Needle Up/Down switch, 7 – 8
- Needles, 8
 - Source needle replacement procedure, 100
- Nitrogen
 - Connecting the gas source, 110
 - Source requirements, 109
- NOTES in manual, 4

O

- OCP method parameters, 21
- OPEN lever, 8
- Operating humidity, 105
- Operating temperature, 105
- Operation, 25
 - Completing the run, 45
 - Editing a custom method, 49 – 52
 - Filling the cell, 37
 - Installing the cell filter, 34
 - Installing the collection vessel, 39
 - Installing the sample cell, 44
 - Installing the waste bottle, 41
 - Post-run procedures, 46
 - Preparing to run, 25
 - Rinsing the system, 48

- Selecting the method, 42
- Shutdown, 55
- Starting a run, 43
- Stopping a run, 47
- Theory of, 145
- OPP method parameters, 22
- Optimization of methods, 147
- O-rings, 11
 - PTFE part number, 140
 - Replacing, 38, 65
 - Viton part number, 140
- Ottawa sand, 37
- Outlet check valve, 77
- Oven
 - Compression pressure low, 57
 - Location, 7
 - OVEN READY status, 16, 63
 - OVEN WAIT status, 43
 - Temperature high, 58
 - Temperature low, 58
 - Unable to reach temperature, 62
- OVEN READY status, 16, 63
- Oven voltage switches, 112
- OVEN WAIT status, 43
- Overview of ASE 150, 1 – 2

P

- Parameters
 - Displaying values, 11
- Parts, ASE 150, 139
- PCB method parameters, 22
- PDF method parameters, 22
- PEEK seals
 - Part number, 140
 - Replacement procedure, 69, 71
 - When to replace, 54
- Physical specifications, 106
- Piston seals
 - Replacing, 80 – 84
- Pneumatic specifications, 106
- Post-run procedures, 46
- PPE method parameters, 23

- Preparing the sample, 31
- Preparing to run, 25
- Preprogrammed methods, 20
 - Chlorinated herbicides (HRB), 20 – 21
 - Dioxins and furans (PDF), 20, 22
 - Organochlorine pesticides (OCP), 20 – 21
 - Organophosphorous pesticides (OPP), 20, 22
 - Polychlorinated biphenyls (PCB), 20, 22
 - Polymer additives (PPE), 20, 23
 - Semivolatiles (BNA), 20
 - Total fat (FAT), 20 – 21
 - Total petroleum hydrocarbons (TPH), 20, 23
- Pressure readings, 135
 - Checking, 114
 - Unit of measure, 121, 130
- Pressure relief valve
 - Opening for reduced period, 121, 130
 - Operating theory, 17
 - Replacing, 85 – 86
 - When to replace, 67
- Printed circuit board (main), 60, 67
- Processing extracts, 46
- PTFE O-rings, 11
 - Part number, 140
 - Replacing, 38
 - When to replace, 54
- Pump
 - Check valve replacement, 76 – 79
 - Piston seal replacement, 80 – 84
- Pump head leaks, 66
- Purge time
 - Description, 132
 - Guidelines for selecting, 50, 132

R

- Rear panel, 15
 - Illustration, 15, 111
- Regulators screen, 135
- Replacement parts, 139 – 142
- Reservoir, solvent, 14

- See also* Solvent reservoir
- Right-side panel
 - Reinstalling, 75
 - Removing, 74 – 75
- Rinse button, 10
 - LED is lighted, 10
- Rinse cells
 - Cannot fit in cell holder, 118
 - Installation, 44, 123
 - Matching to sample cell size, 12, 48, 122
 - Sizes available, 12, 122
- Rinse cycle, 12
 - Performing, 48
 - Starting, 10
 - When to run, 48
- Rinse cycle during a method, 49
 - When to run multiple, 52
- Rinse volume, 19
 - Description, 132
 - Effect of increasing, 53
 - Not delivered, 62
- Running, 42
 - Checking oven status, 43
 - Completing the run, 45
 - Filling the cell, 37
 - Filling the solvent reservoir, 29
 - Installing the cell filter, 34
 - Installing the collection vessel, 39
 - Installing the sample cell, 44
 - Installing the waste bottle, 41
 - Post-run procedures, 46
 - Preparing the sample, 31
 - Preparing to run, 25
 - Rinsing the system, 48
 - Sarting, 43
 - Selecting the method, 42
 - Selecting the solvent, 25
 - Stopping a run, 47
- S**
- Safety diagnostics, 2
- Safety icons, 3 – 4
- Safety messages, 3 – 4
- Safety standards and labels, 5
- Sample
 - Difficult to extract, 53
 - Dry, 32
 - Liquid, 32
 - Loading into cell, 37
 - Wet, 31 – 32
- Sample cell end cap, 11
 - O-rings, PTFE, 140
 - O-rings, Viton, 140
 - Part numbers, 139 – 140
 - Replacing the seal, 69, 71
 - Snap ring, 140
- Sample cell specifications, 106
- Sample cells, 8
 - Cannot fit in cell holder, 118
 - Changing the size, 12
 - Handling hot cells, 45, 118
 - Installation, 44, 123
 - Matching to rinse cell size, 12, 48, 122
 - Moving the cell holder, 118
 - Plugged, 58, 62
 - Pressure threshold exceeded, 58
 - Recommended purge times, 50, 132
 - Replacing the O-ring, 73
 - Specifying the size, 120, 130
- Sample preparation, 31
 - Dispersing agents, 31
 - Drying agents, 31
 - Grinding, 31, 33
- Schematic, 145
- Screwdriver, flathead, 38, 73, 91
- Seals
 - AutoSeal, 8
 - Cell end cap, 11
 - Cell end cap seal replacement, 69
 - Pump seal replacement, 80
 - Static valve seal replacement, 87
 - When to replace cell end cap seals, 54
 - When to replace static valve seals, 55
- Selectivity in extraction, 154
- Sensors screen, 134
- Septum (collection vessel), 13

- Serial number, 15
 - Service procedures
 - Cell end cap seal replacement, 69, 71
 - Cell O-ring replacement, 73
 - Cell seal replacement, 69, 71
 - Check valve cleaning, 78
 - Check valve replacement, 76 – 79
 - Fuse replacement, 103
 - Piston seal replacement, 80 – 84
 - Pressure relief valve replacement, 85 – 86
 - Right-side panel removal, 74 – 75
 - Source needle replacement, 100 – 102
 - Static valve rebuild, 87 – 91, 93 – 98
 - Set point temperature, 43
 - Setup screen, 130
 - Ship Kit, 14, 110
 - Shutdown, 55
 - Snap ring, 70 – 71, 140
 - Snap ring tool, 70, 140
 - Soil extracts, 151
 - Solvent flow path
 - Illustration, 66
 - Liquid leaks, 65
 - Solvent level in reservoir, 29, 115
 - Solvent lines
 - Air, 48
 - Solvent reservoir, 8, 14
 - Cap assembly, 14, 141
 - Connecting to the ASE 150, 115 – 116
 - End-line filter, 115
 - Filling, 29
 - Filter, 29
 - Installing cap, 29
 - Part number, 141
 - Solvent level required, 29, 115
 - Solvent/sample equilibrium, 53
 - Solvents
 - Autoignition points, 25
 - Degassing, 26
 - Reducing usage, 37
 - Rinsing after a change, 48
 - Selecting, 25 – 26
 - Selection guidelines, 26
 - Source needle, 8
 - Liquid drips, 59, 67
 - Maintenance, 55
 - Moving, 8
 - Replacing, 100 – 102
 - Soxhlet extractions, 26, 46, 143
 - Spare parts, 139 – 142
 - Specifications
 - Collection vessels, 106
 - Display and keypad, 106
 - Electrical, 105
 - Environmental, 105
 - Interior components, 107
 - Physical, 106
 - Pneumatic, 106
 - Sample cells, 106
 - Stainless steel frit, 11
 - Stainless steel sample cells, 11
 - Part numbers, 139
 - Start button, 10
 - Start LED is lit, 10
 - Startup Kits, 110
 - Static cycle, 17, 52
 - Liquid leaks during, 67
 - Specifying in the method, 50, 132
 - When to use multiple, 52
 - Static time, 19, 52
 - Specifying in method, 131
 - Static valve, 67
 - Operating theory, 17
 - Rebuilding, 87 – 91, 93 – 98
 - Repair Kit, 87
 - Tool Kit, 87
 - When to rebuild, 59, 67, 87
 - Status screen, 129
 - Monitoring a run, 18
 - Stop button, 10
 - Stop LED is lit, 10
 - Stopping a run, 47
- ## T
- Technical Support, 57
 - Contacting, 69

Temperature

Increasing to improve extraction, 52

Reaching the set point, 43

Temperature, operating, 105

Theory of ASE, 143

Thermal gloves, 45, 118

Thermo Fisher Scientific Technical Support, contacting, 69

Tools

Cell filter insertion, 36, 140

Flathead screwdriver, 38, 73

Snap ring, 70, 140

Static Valve Tool Kit, 87

TPH method parameters, 23

Troubleshooting, 57

Electrical cables, 67

Error messages, 57

Excessive cell pressure, 58

Liquid leaks, 65 – 67

System stopped, 67

Tubing

Vent, 111

U

Up/Down switch, 7 – 8

V

Valves

Pressure relief, 17, 85

Static, 17, 87

Vapor threshold exceeded, 61

Vent lines, 14

Vent needles, 8

Moving, 8

Vent, system, 8

Viton O-rings, 11

Part number, 140

Replacing, 38

When to replace, 54

When to use, 11

Voltage switches, 112

W

Warning icon, 3

Waste bottle, 8, 14

Cap, 14

Connections, 14

Description, 8

Installation, 41, 117

Liquid leaks during static cycle, 67

Maintenance, 14, 54

Weight of ASE 150, 106, 109

Z

Zirconium sample cells, 11

Part numbers, 139

Selecting in the method, 50

When to use, 11