

# EFD1000 E5 Dual Electronic Flight Instrument (EFI) Installation Manual

April 2019

## Special Notes to the Installer

It is important to review the entire Installation Manual before installing the EFD1000 E5. The following items are of special note and should be considered for planning and installation.

Correct placement of the aircraft instruments is critical to maintain the aircraft certification. Certain instruments can be removed. More importantly, certain instruments must not be removed, See Section 4. The existing turn/bank instrument or a backup attitude indicator must be retained for all installations except Aircraft Limited to VFR, See Section 4.5.

This installation is not authorized in aircraft with a MTOW exceeding 6000 pounds.

The EFD1000 E5 does not display Flight Director. The existing flight director indicator will need to be retained and relocated. See section 4.4.3

The RSM contains magnetic elements that are sensitive to magnetic fields on the aircraft. Section 6.9 describes locating the RSM installation. Mounting the RSM over the cabin can be problematic due to passengers using headsets with magnetic speakers. Exercise the control cables while validating a location. Consider all the magnetic field variations. A satisfactory RSM location is part of the Final Check Sheet. Use caution when installing the RSM connector to avoid damaging the connector or wiring.

The RSM can be damaged if exposed to a magnet. Do not use magnetic tools or magnetic levels near the RSM.

The installer must determine whether the design changes described in this document are compatible with previously approved modifications.

**DOCUMENT REVISIONS**

Revisio	Description of Change	ECO
( )	Original Revision	5465
A	Updated manual for initial release to the field	5483
B	Removed Special Conditions for Aircraft Limited to VFR. Clarified regulatory wording and typographical errors.	5578
C	Corrected the transmit rate for the ARINC 429 outputs. Added a date to the cover. Updated paragraph 7.2.11 to add tubing.	5588
D	Added Figure 4-1A, "VFR Configuration". Added Section 4.5, Special Considerations for Aircraft Limited to VFR. Added Figure 9-4 "VFR Only - No GPS input Configurations" and updated Fig 9-10 to add VFR config with NAV, no GPS. Added VFR configs to 10.4.6.8. Added step to Appdx B - Final Check Sheet to verify aircraft is placarded for VFR- if limited to VFR.	5718
<i>Prepared By:</i>	Tim McNany	<i>Reviewed By:</i> Mike Studley / Penny Heinz
See ECO Record For Release Authorization		

This manual contains FAA Approved installation instructions for installation of the Aspen™ EFD1000 E5 system under the AML STC for use as an electronic flight display during day/night IFR and VFR operations in those Part 23 Class I and II aircraft (as defined in AC 23.1309-1E) listed on the AML. Installation of the EFD1000 E5 into part 23 Class I or II aircraft not included in the AML, into any 14 CFR Part 23 Class III or IV aircraft, or into any part 25, 27, or 29 aircraft, or non-U.S. registered aircraft requires separate airworthiness approval.

This document is protected by the Copyright Laws of the United States and other countries. Nevertheless, authorized Aspen dealers and distributors are licensed to make a reasonable number of verbatim copies of this document for use in their business as Aspen dealers.

Reproduction for any other purpose is strictly prohibited.

Public or fee-based copy centers need not inquire into the bearer's status as an Aspen dealer or distributor, into the purposes for which reproductions are to be made, or into the reasonableness of the number of reproductions requested.

**Table of Contents:**

LIST OF TABLES..... 12

LIST OF FIGURES..... 13

LIST OF DEFINITIONS, ACRONYMS, ABBREVIATIONS ..... 16

1 INTRODUCTION ..... 17

    1.1 PART NUMBERS ..... 17

        1.1.1 LATEST APPROVED SOFTWARE VERSIONS..... 17

        1.1.2 AML–STC DOCUMENT LIST ..... 18

    1.2 INSTALLATION KIT CONTENTS..... 18

    1.3 OPTIONAL LRU INSTALL KITS ..... 19

    1.4 ACCESSORIES REQUIRED BUT NOT SUPPLIED – EFD1000 E5 ..... 20

    1.5 OPTIONAL ACCESSORIES NOT SUPPLIED – EFD1000 E5 ..... 20

    1.6 OPTIONAL ACCESSORIES REQUIRED BUT NOT SUPPLIED – EA100 ..... 20

    1.7 SPECIAL TOOLS REQUIRED ..... 21

    1.8 VENDOR INFORMATION ..... 21

    1.9 WARRANTY REGISTRATION..... 21

    1.10 REGULATORY COMPLIANCE ..... 21

        1.10.1 TECHNICAL STANDARD ORDER ..... 21

        1.10.2 PMA APPROVAL ..... 21

        1.10.3 SOFTWARE CERTIFICATION..... 22

        1.10.4 ENVIRONMENTAL COMPLIANCE..... 22

        1.10.5 INSTALLATION APPROVAL ..... 22

    1.11 FIELD REPLACEABLE PARTS..... 22

    1.12 RESERVED ..... 22

2 EQUIPMENT SPECIFICATIONS AND LIMITATIONS ..... 23

    2.1 EFD1000 E5..... 23

        2.1.1 GENERAL SPECIFICATIONS ..... 23

        2.1.2 OPERATIONAL SPECIFICATIONS..... 23

        2.1.3 I/O SPECIFICATIONS ..... 23

        2.1.4 CERTIFICATION SPECIFICATIONS ..... 23

        2.1.5 EFD1000 E5 OUTLINE DRAWING ..... 24

        2.1.6 DESIGN EYE VIEWING ENVELOPE ..... 24

    2.2 REMOTE SENSOR MODULE (RSM) ..... 25

        2.2.1 GENERAL SPECIFICATIONS ..... 25

        2.2.2 OPERATIONAL SPECIFICATIONS..... 25

        2.2.3 I/O SPECIFICATIONS ..... 25

        2.2.4 CERTIFICATION SPECIFICATIONS ..... 25

        2.2.5 OUTLINE DRAWING: ..... 26

    2.3 CONFIGURATION MODULE (CM)..... 26

        2.3.1 GENERAL SPECIFICATIONS..... 26

        2.3.2 OPERATIONAL SPECIFICATIONS..... 27

        2.3.3 I/O SPECIFICATIONS ..... 27

        2.3.4 CERTIFICATION SPECIFICATIONS ..... 27

        2.3.5 OUTLINE DRAWING ..... 27

	2.4	ANALOG CONVERTER UNIT (ACU) .....	28
	2.4.1	GENERAL SPECIFICATIONS .....	28
	2.4.2	OPERATIONAL SPECIFICATIONS .....	28
	2.4.3	I/O SPECIFICATIONS .....	28
	2.4.4	CERTIFICATION SPECIFICATIONS .....	28
	2.4.5	OUTLINE DRAWING: .....	29
	2.5	ANALOG CONVERTER UNIT 2 .....	29
	2.5.1	GENERAL SPECIFICATIONS .....	29
	2.5.2	OPERATIONAL SPECIFICATIONS .....	29
	2.5.3	I/O SPECIFICATIONS .....	29
	2.5.4	CERTIFICATION SPECIFICATIONS .....	30
	2.5.5	OUTLINE DRAWING .....	30
3		SYSTEM DESCRIPTION .....	31
	3.1	EFD1000 E5 DUAL ELECTRONIC FLIGHT INSTRUMENT (EFI) SYSTEM.....	31
	3.2	EFD1000 E5 FLIGHT DISPLAY (EFD).....	31
	3.3	REMOTE SENSOR MODULE (RSM) .....	32
	3.4	CONFIGURATION MODULE (CM).....	32
	3.5	ANALOG CONVERTER UNIT (ACU) .....	32
	3.6	ANALOG CONVERTER UNIT 2 (ACU2) .....	32
	3.7	SYSTEM ARCHITECTURE .....	33
4		STC SPECIFIC REQUIREMENTS AND LIMITATIONS .....	35
	4.1	EFD1000 E5 SYSTEM LIMITATIONS.....	35
	4.2	EA100 INSTALLATION LIMITATIONS (EA100 IS OPTIONAL) .....	35
	4.3	AUTHORIZED CONFIGURATIONS.....	35
	4.4	GENERAL STANDBY INSTRUMENT REQUIREMENTS FOR IFR-CAPABLE AIRPLANES .....	38
	4.4.1	PNEUMATIC ATTITUDE (EXISTING) .....	38
	4.4.2	ELECTRIC ATTITUDE (EXISTING) .....	38
	4.4.3	EXISTING ATTITUDE POSITIONING (IF KEEPING).....	38
	4.4.4	AIRSPED AND ALTIMETER .....	40
	4.4.5	BACK UP NAV INDICATOR.....	40
	4.4.6	PLACARDS.....	40
	4.5	SPECIAL CONSIDERATION FOR AIRPLANES LIMITED TO VFR .....	41
5		PRE-MODIFICATION PLANNING .....	42
	5.1	PRE-MODIFICATION CHECKLIST .....	42
	5.1.1	DIRECTIONAL GYRO/ HSI.....	43
	5.1.2	AIRCRAFT POWER REQUIREMENTS .....	43
	5.1.3	EQUIPMENT POWER REQUIREMENTS .....	43
	5.1.4	RESERVED .....	43
	5.1.5	CESSNA 190/195 SPECIAL CONSIDERATION .....	44
	5.2	RESERVED .....	44
	5.3	CONVENTIONAL LANDING GEAR "TAIL DRAGGER" AIRCRAFT .....	44
	5.4	OPTIONAL INTERFACES .....	45
	5.4.1	AUTOPILOT .....	45
	5.4.1.1	EA100 ADAPTER.....	45
	5.4.2	GPS NAVIGATOR COMPATIBILITY .....	46

	5.4.3	GPSS .....	46
	5.4.4	GPS/ NAV SWITCHING .....	46
	5.4.5	HEADING OUTPUT .....	47
	5.4.6	AIR DATA OUTPUTS.....	47
	5.4.6.1	EFD1000 E5 AS ENCODING ALTITUDE SOURCE .....	47
6	5.4.7	FLUSH OR RECESS MOUNTING THE EFD .....	48
		MECHANICAL INSTALLATION.....	50
	6.1	UNPACKING AND INSPECTING EQUIPMENT.....	50
	6.2	EQUIPMENT LOCATION DOCUMENTATION.....	50
	6.3	LOG BOOK ENTRY .....	50
	6.4	WEIGHT AND BALANCE .....	50
	6.5	MOUNTING LIMITATIONS .....	50
	6.5.1	EFD1000 E5 MOUNTING LIMITATIONS (EFD).....	51
	6.5.2	RSM MOUNTING LIMITATIONS .....	51
	6.6	EQUIPMENT BONDING .....	51
	6.7	COOLING .....	52
	6.8	EFD INSTALLATION .....	52
	6.8.1	EFD MOUNTING LOCATION .....	52
	6.8.2	SURFACE MOUNTING THE EFD AS PER FIGURE 6-2 .....	52
	6.8.3	RECESS MOUNTING THE EFD AS PER FIGURE 6-4 .....	54
	6.8.3.1	RECESS MOUNT MODIFICATION PROCEDURE .....	54
	6.8.4	EFD BONDING STRAP .....	59
	6.8.5	PITOT AND STATIC CONNECTIONS .....	59
	6.8.6	QUICK CONNECTOR INSTALLATION .....	60
	6.8.7	LEAK CHECK REQUIREMENTS .....	60
	6.9	RSM INSTALLATION.....	61
	6.9.1	RSM INTERNAL MOUNTING.....	61
	6.9.2	RSM INVERTED OR BOTTOM MOUNTING.....	61
	6.9.3	RSM EXTERNAL TOP MOUNTING .....	61
	6.9.4	PROPOSED RSM LOCATION CHECK .....	65
	6.9.5	PRESSURIZED AIRCRAFT.....	67
	6.9.6	RSM MOUNTING ON NON-METAL OR DAMAGE-TOLERANT DESIGN AIRCRAFT.....	68
	6.9.7	RSM MOUNTING ANGLES .....	68
	6.9.7.1	LONGITUDINAL AXIS .....	68
	6.9.7.2	PITCH AXIS.....	68
	6.9.7.3	ROLL AXIS.....	69
	6.9.8	RSM EXTERNAL MOUNT - ALUMINUM SKIN .....	70
	6.9.8.1	RSM DOUBLER FABRICATION.....	70
	6.9.9	RSM INTERNAL MOUNT .....	72
	6.9.10	RSM INSTALLATION.....	72
	6.9.11	RSM SHIM FABRICATION (IF NECESSARY).....	73
	6.10	ACU/ACU2 INSTALLATION.....	74
	6.10.1	ACU/ACU2 MOUNTING .....	75
7	6.11	CONFIGURATION MODULE INSTALLATION.....	78
		ELECTRICAL INSTALLATION.....	80

7.1	ELECTRICAL LOAD ANALYSIS .....	80
7.2	ELECTRICAL INSTALLATION .....	80
7.2.1	EFD1000 E5.....	80
7.2.2	ACU OR ACU2 (OPTIONAL).....	80
7.2.3	MISCELLANEOUS WIRING .....	80
7.2.4	HIRF/LIGHTNING REQUIREMENTS .....	81
7.2.5	EFD TO GPS/VLOC/ACU WIRING .....	81
7.2.6	RSM WIRING .....	82
7.2.6.1	ASSEMBLY USING ASPEN PREFABRICATED 35FT AND OPTIONAL 50FT CABLES .....	82
7.2.6.2	ASSEMBLY USING M27500-A24SD7T23 CABLE .....	82
7.2.6.3	EFD END.....	83
7.2.7	CONFIGURATION MODULE WIRING .....	83
7.2.8	ACU WIRING .....	84
7.2.9	BACK UP NAV INDICATOR WIRING.....	84
7.2.10	AUTOPILOT WIRING .....	84
7.2.11	BACKUP INSTRUMENT WIRING AND CABLE BUNDLE .....	84
8	ELECTRICAL CONNECTIONS.....	86
8.1	EFD ELECTRICAL SPECIFICATIONS .....	86
8.1.1	POWER INPUT.....	86
8.1.2	RS-232 GPS INPUT.....	86
8.1.3	RS-232 ADC OUTPUT.....	86
8.1.4	ARINC 429 GPS INPUTS.....	86
8.1.5	ARINC 429 VLOC INPUT .....	87
8.1.6	ARINC 429 OUTPUT .....	87
8.2	ACU ELECTRICAL SPECIFICATIONS (910-00004 ALL DASH NUMBERS) .....	88
8.2.1	POWER INPUT.....	88
8.2.2	RESERVED .....	88
8.2.3	VLOC RECEIVER.....	88
8.2.3.1	NAV COMPOSITE INPUT.....	88
8.2.3.2	ILS ENERGIZE DISCRETE INPUT .....	88
8.2.3.3	GLIDE SLOPE DEVIATION INPUT .....	88
8.2.3.4	GLIDE SLOPE FLAG INPUT .....	89
8.2.4	GPS RECEIVER.....	89
8.2.4.1	OBS SINE, COSINE, ROTOR.....	89
8.2.4.2	TO/ FROM FLAG INPUT.....	89
8.2.4.3	LEFT/ RIGHT INPUT.....	89
8.2.4.4	LATERAL FLAG INPUT .....	89
8.2.4.5	VERTICAL DEVIATION INPUT .....	89
8.2.4.6	VERTICAL DEVIATION FLAG INPUT.....	89
8.2.4.7	OBS/ LEG (HOLD) INPUT .....	89
8.2.4.8	APPR ACTIVE INPUT .....	90
8.2.4.9	FCS-LOC ENGAGE INPUT .....	90
8.2.5	AUTOPILOT .....	90
8.2.5.1	LATERAL DEVIATION OUTPUT .....	90
8.2.5.2	LATERAL FLAG OUTPUT .....	90

8.2.5.3	VERTICAL DEVIATION OUTPUT .....	90
8.2.5.4	VERTICAL FLAG OUTPUT .....	90
8.2.5.5	ILS ENERGIZE OUTPUT .....	90
8.2.5.6	VOLT REFERENCE OUTPUT .....	91
8.2.5.7	KI-525A HEADING AND COURSE DATUM OUTPUT .....	91
8.2.5.8	NSD-360 HEADING AND COURSE DATUM OUTPUT .....	91
8.2.5.9	PN-101 HEADING AND COURSE DATUM OUTPUT .....	92
8.2.5.10	HEADING VALID OUTPUT.....	92
8.2.5.11	GPS SELECTED OUTPUT .....	93
8.2.5.12	ARINC 429 OUTPUT .....	93
8.3	ACU2 ELECTRICAL SPECIFICATIONS (910-00004-10X ONLY).....	93
8.3.1	HEADING SYNCHRO OUT .....	93
8.3.2	+/- 15VDC POWER OUTPUT .....	94
8.3.3	GLIDESLOPE FLAG (NARCO).....	94
8.3.4	ARINC 429 OUTPUT .....	94
8.4	EFD PIN OUT .....	94
8.5	RSM PIN OUT .....	96
8.6	CONFIGURATION MODULE PIN OUT .....	96
8.7	ACU/ACU2 PIN OUT.....	97
9	INSTALLATION WIRING DIAGRAMS.....	102
9.1	LIST OF WIRING DIAGRAMS - EFD1000 E5 .....	102
9.2	OPTIONAL INTERFACES - ACU AND ACU2.....	103
10	CONFIGURATION AND EQUIPMENT CHECKOUT .....	134
10.1	WIRING CHECKS.....	134
10.2	BONDING CHECK - 14CFR 23.867(B).....	134
10.3	INITIAL SYSTEM TURN ON.....	134
10.4	SYSTEM CONFIGURATION.....	135
10.4.1	MAIN MENU ACCESS .....	135
10.4.2	MENU NAVIGATION .....	135
10.4.3	EDIT MODE .....	135
10.4.4	MAIN MENU CONFIGURATION .....	135
10.4.5	INSTALLATION MENU - UNIT CONFIGURATION.....	135
10.4.6	EFD1000 E5 INSTALLATION MENU CONFIGURATION .....	138
INSTALLATION MENU CONFIGURATION - EFD1000 E5 .....		138
10.4.6.1	INSTALLATION MENU PAGE - IAS CONFIG A.....	138
10.4.6.2	INSTALLATION MENU PAGE - IAS CONFIG B.....	140
10.4.6.3	INSTALLATION MENU PAGE - IAS CONFIG C .....	140
10.4.6.4	INSTALLATION MENU PAGE - IAS CONFIG D .....	140
10.4.6.5	INSTALLATION MENU PAGE - IAS CONFIG E.....	140
10.4.6.6	INSTALLATION MENU PAGE - IAS CONFIG F .....	141
10.4.6.7	INSTALLATION MENU PAGE - IAS CONFIG G.....	141
10.4.6.8	INSTALLATION MENU PAGE - NAV SETUP A.....	142
10.4.6.9	INSTALLATION MENU PAGE - NAV SETUP B .....	142
10.4.6.10	INSTALLATION MENU PAGE - NAV SETUP C.....	143
10.4.6.11	INSTALLATION MENU PAGE - RS-232 CONFIG A.....	143

10.4.6.12	INSTALLATION MENU PAGE – RS-232 CONFIG B .....	144
10.4.6.13	INSTALLATION MENU PAGE – RS-232 CONFIG C .....	144
10.4.6.14	INSTALLATION MENU PAGE – ACU CONFIG A .....	144
10.4.6.15	INSTALLATION MENU PAGE – ACU CONFIG B .....	145
10.4.6.16	INSTALLATION MENU PAGE – MISC CONFIG A .....	145
10.4.6.17	INSTALLATION MENU PAGE – MISC CONFIG B .....	145
10.4.6.18	INSTALLATION MENU PAGE – MISC CONFIG C .....	146
10.4.6.19	INSTALLATION MENU PAGE – MISC CONFIG D .....	146
10.4.6.20	INSTALLATION MENU PAGE – RSM CALIBRATION .....	146
10.4.6.21	INSTALLATION MENU PAGE – ACCEL BIAS CAL .....	148
10.4.6.22	INSTALLATION MENU PAGE – WX-500 .....	148
10.4.6.23	INSTALLATION MENU PAGE – DFC A/P CONFIG PAGE A .....	148
10.4.6.24	INSTALLATION MENU PAGE – DFC A/P CONFIG PAGE B .....	148
10.4.6.25	INSTALLATION MENU PAGE – AOA CONFIG .....	148
10.4.6.26	INSTALLATION MENU PAGE – NETWORK PAGE .....	148
10.4.6.27	INSTALLATION MENU PAGE – DIAGNOSTICS .....	149
10.4.7	CONFIGURATION DEFINITIONS .....	149
10.4.7.1	IAS CONFIGURATIONS .....	149
10.4.7.2	PANEL TILT PITCH ADJ .....	150
10.4.7.3	PANEL ROLL ADJ .....	152
10.4.7.4	ATTITUDE REF SYMBOL ADJ .....	152
10.4.8	NAV SETUP CONFIGURATION .....	152
10.4.8.1	GPS/NAV#1 (ID#1) .....	152
10.4.8.2	COMPOSITE PHASE (VOR1, VOR2) .....	152
10.4.9	ACU CONFIGURATION .....	152
10.4.9.1	ACU HSI TYPE .....	152
10.4.9.2	ACU DATUM .....	153
10.4.9.3	EXITING / SAVING DATA .....	153
10.5	RSM CALIBRATION .....	153
10.5.1	CALIBRATION OVERVIEW .....	153
10.5.1.1	SECOND PHASE RSM LOCATION EVALUATION .....	154
10.5.1.2	CONVENTIONAL GEAR RSM CALIBRATION PROCEDURE .....	156
10.5.2	RSM CALIBRATION PROCEDURE .....	158
10.5.3	HEADING OFFSET ADJUSTMENT .....	160
10.5.3.1	HEADING OFFSET ADJUSTMENT .....	160
10.5.4	HEADING ACCURACY TEST .....	161
10.5.5	HEADING INTERFERENCE TEST .....	161
10.6	GROUND TEST PROCEDURE .....	162
10.6.1	INDICATED AIRSPEED DISPLAY .....	162
10.6.2	ALTITUDE DISPLAY .....	163
10.6.3	SYSTEM LEAK TEST .....	163
10.6.4	AHRS SENSOR TEST .....	163
10.6.5	GPS1 SENSOR TEST (LABELED AS GPS1) .....	163
10.6.5.1	ALL GPS INTERFACES .....	163
10.6.5.2	ANALOG GPS INTERFACES .....	163

10.6.6	NAV RECEIVER SENSOR TEST (LABEL AS VLOC1).....	164
10.6.7	BACKUP NAVIGATION INDICATOR.....	164
10.6.8	AUTOPILOT SENSOR TEST .....	164
10.6.9	ANCILLARY EQUIPMENT HEADING CHECK .....	165
10.6.10	ANCILLARY EQUIPMENT AIR DATA CHECK .....	165
10.6.11	INTERNAL BATTERY TESTS .....	165
10.6.12	TAPES CONFIGURATION CHECK.....	165
10.6.13	EMI TEST .....	166
10.6.14	FLIGHT CONTROL INTERFERENCE CHECK.....	169
10.6.15	OBS MODE CHECK.....	169
10.6.16	EA100 ADAPTER TESTING .....	170
11	POST INSTALLATION FLIGHT CHECK .....	171
11.1	ATTITUDE DISPLAY FLIGHT CHECKS.....	171
11.2	HEADING CARD FLIGHT CHECKS.....	171
11.3	ILS FLIGHT CHECKS .....	171
11.4	AUTOPILOT FLIGHT CHECKS (IF INSTALLED) .....	172
11.5	DOCUMENT OPERATIONAL CHECK .....	172
12	OPERATING INSTRUCTIONS .....	173
12.1	PILOT CONTROLS .....	173
12.1.1	OVERVIEW.....	173
12.1.2	POWER CONTROL.....	173
13	ENVIRONMENTAL QUALIFICATION FORMS.....	175
APPENDIX A	: TROUBLESHOOTING.....	179
APPENDIX B	: INSTALLATION FINAL CHECK SHEET.....	185
APPENDIX C	: SAMPLE OF AFMS SECTION 1.2 (INSTALLED EQUIPMENT CONFIGURATION MATRIX) 190	
APPENDIX D	: COMPONENT MAINTENANCE MANUAL (CMM).....	193
APPENDIX E	: EA100 ADAPTER.....	195
E1	GENERAL LIMITATIONS .....	196
E2	EA100 SPECIFICATIONS.....	197
E3	OUTLINE DRAWING:.....	198
E4	EA100 SYSTEM ARCHITECTURE .....	198
E5	EA100 INSTALLATION.....	199
E5.1	EQUIPMENT LOCATION DOCUMENTATION .....	199
E5.2	WEIGHT AND BALANCE .....	199
E5.3	MECHANICAL INSTALLATION.....	199
E5.4	ELECTRICAL INSTALLATION.....	201
E5.5	FABRICATION OF TR1 OR TR2 TRANSFORMER ISOLATION BOX (CENTURY AUTOPILOTS ONLY).....	203
E5.6	ELECTRICAL CONNECTION .....	204
E5.7	WIRING DIAGRAMS.....	205
E5.8	CONFIGURATION .....	220
E5.9	EA100 GROUND TEST PROCEDURE .....	220
E5.9	AUTOPILOT GYRO ALIGNMENT .....	222
E5.10	GROUND EMI TEST.....	222

## List of Tables

Table 1-1: Part Numbers.....	17
Table 1-2: Latest Approved Software Version.....	17
Table 1-3: AML-STC Additional Document List .....	18
Table 1-4: 903-00001-( ) EFD1000 EFD Install Kit.....	18
Table 1-5: 903-00007-001 EFD Recess Mount Kit (optional) .....	18
Table 1-6: 903-00002-( ) RSM Install Kits .....	18
Table 1-7: 903-00003-001 ACU Install Kit.....	19
Table 1-8: 903-00003-002 ACU2 Install Kit.....	19
Table 1-9: 903-00011-( ) EA100 Install Kits.....	19
Table 1-10: EFD1000 E5 Accessories Required but Not Supplied .....	20
Table 1-11: E5 Optional Accessories Not Supplied .....	20
Table 1-12: EA100 Optional Accessories Required but Not Supplied.....	20
Table 1-13: Special Tools.....	21
Table 5-1: Pre-Modification Checklist .....	42
Table 5-2: GPS Compatibility.....	46
Table 5-3: Heading Sources .....	47
Table 5-4: Air Data Sources .....	47
Table 6-1: Component Weights.....	50
Table 6-2: Parts Required to Recess Mount each EFD .....	54
Table 6-3: Static Load Table.....	57
Table 6-4: RSM Mounting Hardware .....	72
Table 7-1: Current Draw .....	80
Table 8-1: RS-232 ADC Outputs .....	86
Table 8-2: EFD A429 GPS Input .....	87
Table 8-3: EFD A429 VLOC Input.....	87
Table 8-4: EFD1000 E5 A429 GPS Output .....	88
Table 8-5: KI525A Emulation Specifications.....	91
Table 8-6: NSD360A Emulation Specifications .....	92
Table 8-7: PN101 Emulation Specifications.....	92
Table 8-8: ACU A429 Output .....	93
Table 8-9: ACU2 ARINC 429 Output .....	94
Table 8-10: EFD Pin Out.....	95
Table 8-11: RSM Pin Out.....	96
Table 8-12: Configuration Module Pin Out.....	96
Table 8-13: ACU J1 Pin Out .....	97
Table 8-14: ACU J2 Pin Out .....	98
Table 8-15: ACU J3 Pin Out .....	99
Table 9-1: E5 Wiring Diagrams.....	103
Table 9-2: Optional ACU/ACU2 Interfaces .....	103
Table 10-1 MOL Type and Parameter Descriptions.....	139
Table 10-2: Vertical Component Evaluation table.....	154
Table 13-1: EFD1000 E5 Environmental Qualification Form .....	175
Table 13-2: RSM Environmental Qualification Form.....	176

Table 13-3: ACU Environmental Qualification Form..... 177

**List of Figures**

Figure 2-1: EFD1000 E5 Outline Drawing (inches) ..... 24

Figure 2-2: RSM Outline Drawing (inches)..... 26

Figure 2-3: Configuration Module Outline Drawing (inches) ..... 27

Figure 2-4: ACU Outline Drawing (inches)..... 29

Figure 2-5: ACU2 Outline Drawing (inches)..... 30

Figure 3-1: EFD1000 E5 System Architecture ..... 33

Figure 4-1: EFD1000 E5 Authorized IFR Configuration ..... 36

Figure 4-2: Flight Director/Backup Nav/Placard placement..... 39

Figure 6-1: EFD Mounting Location ..... 52

Figure 6-2: EFD and Bracket Installation ..... 53

Figure 6-3: Single Display Recess Mount Cutout (inches)..... 55

Figure 6-4: Single Display Recess Mount Bracket Installation..... 56

Figure 6-5: Ground Strap Attachment Points..... 57

Figure 6-6: Recess Mounting Bracket Dimensions (inches) ..... 58

Figure 6-7: EFD Mounting Bracket (inches) ..... 58

Figure 6-8: EFD Bonding Strap Connection ..... 59

Figure 6-9: Pitot & Static Quick Connector..... 59

Figure 6-10: Pitot & Static Line Connections ..... 60

Figure 6-11: RSM-External Mounting Locations (Top/Side View) - all aircraft types ..... 63

Figure 6-12: RSM Internal Mounting Locations - Composite/Fabric Aircraft ..... 64

Figure 6-13: RSM-003 External Mounting Locations (Bottom view) ..... 65

Figure 6-14: RSM Top View longitudinal Alignment..... 68

Figure 6-15: RSM Fore or Aft Max Tilt..... 69

Figure 6-16: RSM Fore or Aft Max Tilt (Shim installed)..... 69

Figure 6-17: RSM Side to Side Max Tilt ..... 69

Figure 6-18: RSM Side to Side Max Tilt (Shim installed) ..... 69

Figure 6-19: RSM Doubler P/N 503-00015-001 ..... 70

Figure 6-20: Masking of Doubler..... 71

Figure 6-21: Doubler Installation ..... 72

Figure 6-22: RSM Mounting ..... 73

Figure 6-23: Example Shim Top View ..... 73

Figure 6-24: Example Shim Side View..... 73

Figure 6-25: Masking of Shim for Priming ..... 74

Figure 6-26: ACU/ACU2 Mount to Flat Metal Shelf ..... 75

Figure 6-27: ACU Dimensions (inches) ..... 76

Figure 6-28: ACU2 Dimensions (inches) ..... 77

Figure 6-29: Configuration Module Dimensions (inches) ..... 78

Figure 6-30: Configuration Module Tie Wrapped to Harness..... 78

Figure 7-1: EFD Back Shell Grounds..... 81

Figure 7-2: RSM Connector assembly ..... 83

Figure 7-3: EFD Back Shell Grounds/RSM..... 83

Figure 8-1: EFD Connector (as viewed from rear of unit) ..... 95

Figure 8-2: RSM Mating Connector –Install Side ..... 96

Figure 8-3: Configuration Module Connector (Install side)..... 96

Figure 8-4: ACU J1 Connector (as viewed from front of unit) ..... 97

Figure 8-5: ACU J2 Connector (as viewed from front of unit) ..... 98

Figure 8-6: ACU J3 Connector (as viewed from front of unit) ..... 99

Figure 8-7: ACU2 J4 Connector (ACU2 only)..... 101

Figure 9-1: EFD1000 E5 Main Connections ..... 104

Figure 9-2: ACU/ACU2 Input Power ..... 105

Figure 9-3: Reserved ..... 105

Figure 9-4: VFR Only No GPS input configurations ..... 105

Figure 9-5: ARINC 429 GPS without ACU ..... 105

Figure 9-6: GNAV without ACU ("Tracker" or no Autopilot) ..... 106

Figure 9-7: GNAV with ACU (Autopilot)..... 107

Figure 9-8: Reserved ..... 107

Figure 9-9: Reserved ..... 107

Figure 9-10: ARINC 429 GPS with ACU (Analog Nav and/or Autopilot) ..... 108

Figure 9-11: RS-232 GPS with ACU (Analog Nav and/or Autopilot) ..... 109

Figure 9-12: KLN89B & KLN94 RS-232 and Analog to ACU Interface..... 110

Figure 9-13: KLN-90/A/B RS-232 and Analog to ACU Interface ..... 111

Figure 9-14: GX-50/60 & GX-55/65 RS-232 and Analog to ACU Interface ..... 112

Figure 9-15: Analog NAV Interface ..... 113

Figure 9-15A: Narco and Cessna ARC Navigation Radios ..... 114

Figure 9-16: KI525A Emulation (Bendix/King autopilot to ACU)..... 115

Figure 9-17: S-TEC Autopilot to ACU Interface ..... 116

Figure 9-18: Century Autopilot to ACU Interface (minus HDG/CRS Datum)..... 117

Figure 9-18A: NSD360A Emulation (Century 21/31/41/2000/4000) ..... 117

Figure 9-18B: NSD360A Emulation Century 1C388/M, 1C388C/MC Radio Couplers ..... 118

Figure 9-18C: NSD360A Emulation Century 1C388-2/-3 Radio Couplers ..... 119

Figure 9-18D: NSD-360A Emulation Century IV (DC version)..... 120

Figure 9-19: Cessna ARC 300B/400B/800B Autopilot to ACU Interface..... 121

Figure 9-19A: Cessna Navomatic 300/400/800 IFCS to ACU Interface ..... 122

Figure 9-19B: NAVOMATIC 400/400A Autopilot to ACU Interface..... 123

Figure 9-19C: Cessna ARC 300A AC & DC version to ACU Interface ..... 124

Figure 9-19D: Cessna 300 Navomatic to ACU Interface ..... 125

Figure 9-20: Bendix FCS-810 Autopilot to ACU ..... 126

Figure 9-21: Reserved ..... 127

Figure 9-22: Reserved ..... 127

Figure 9-23: Reserved ..... 127

Figure 9-24: Back-up NAV Indicator (Internal Converter)..... 127

Figure 9-25: Back-up NAV Indicator (OBS Resolver) ..... 128

Figure 9-26: Back-up NAV/GPS Indicator (GNS-430/530) ..... 129

Figure 9-27: Non-Aspen Equipment Configuration Notes..... 130

Figure 9-28A: Digital Heading/ADC Outputs ..... 131

Figure 9-28B: ARINC 407 Synchro Output (ACU2 only) ..... 132

Figure 10-1: Installation Menu Access ..... 136

Figure 10–2: Installation Menu Warning ..... 136

Figure 10–3: Notional Diagnostics Page ..... 149

Figure 10–4: Illustration of aircraft 2° nose high ..... 151

Figure 10–5: Illustration of Zero degree pitch adjustment ..... 151

Figure 10–6: GPS/NAV Example..... 152

Figure 10–7: HSI Type Example ..... 153

Figure 10–8: nT Example ..... 155

Figure 10–9: EFD1000 Diagnostic Page Magnetometer Row Example ..... 155

Figure 10–10: RSM Calibration Graphic..... 157

Figure 10–11: RSM Calibration Page ..... 158

Figure 10–12: Calibration in Process..... 159

Figure 10–13: Aircraft Turning ..... 159

Figure 10–14: Accept/Reject Results ..... 159

Figure 10–15: Results Accepted ..... 160

Figure 10–16: Results Rejected..... 160

Figure 10–17: Calibration Heading Before Adjustment ..... 160

Figure 10–18: Calibrated Heading After Adjustment..... 161

Figure E1: EA100 Outline Drawing (inches) and center of gravity ..... 198

Figure E2: EA100 Block Diagram (Bendix King Autopilots) ..... 198

Figure E3: EA100 Block Diagram (Century Autopilots)..... 198

Figure E4: EA100 Mounting ..... 200

Figure E5: A/P AHRS FAIL Annunciator Location ..... 202

Figure E6: MS25041–4 Dimmable “Catseye” ..... 203

Figure E8: EA100 Main Wiring Connections(King and Century) ..... 206

Figure E9: EA100 to KAP100/KAP150/KFC150 Attitude Source w/DISC ..... 207

Figure E10: EA100 to KAP/KFC200 Attitude Source w/DISC ..... 208

Figure E11: EA100 to KFC225 Attitude Source w/DISC..... 209

Figure E12: EA100 to KFC250 (with KA141) Attitude Source w/DISC ..... 210

Figure E13: EA100 to KFC250 (without KA141) Attitude Source w/Disc ..... 211

Figure E14: Reserved..... 211

Figure E15: EA100 to Century IIB Attitude Source w/DISC ..... 212

Figure E16: EA100 to Century III Attitude Source w/DISC ..... 213

Figure E17: EA100 to Century IV Attitude Source w/DISC..... 214

Figure E18: EA100 to Century 21 Attitude Source w/DISC..... 215

Figure E19: EA100 to Century 31 Attitude Source w/DISC..... 216

Figure E20: EA100 to Century 41 Attitude Source w/DISC..... 217

Figure E21: EA100 to Century 2000 Attitude Source w/DISC ..... 218

Figure E22: EA100 to Century 4000 Attitude Source w/DISC..... 219

## List of Definitions, Acronyms, Abbreviations

ACU	.....Analog Converter Unit
ADAHRS	.....Air Data Attitude Heading Reference System
ADC	.....Air Data Computer
ADI	.....Attitude Director Indicator
AI	.....Attitude Indicator
AHRS	.....Attitude and Heading Reference System
AML	.....Approved Model List
AMMD	.....Aerodrome Moving Map Display (geo-referenced airport diagram)
AOA	.....Angle of Attack
A/P	.....Autopilot
A429	.....ARINC 429 interface
CM	.....Configuration Module
DG	.....Directional Gyro
DH	.....Decision Height
EFD	.....Electronic Flight Display
EFD1000 E5	.....EFD1000 E5 system
EFI	.....Electronic Flight Instrument
EHA	.....Evolution Hazard Awareness
ESV	.....Evolution Synthetic Vision
FAR	.....Federal Aviation Regulations
FD	.....Flight Director
FPM	.....Flight Path Marker
GNAV	.....Combined GPS and VOR radio (all A429 interface)
GPS	.....Global Positioning System
GPSS	.....GPS Steering
GS	.....Glide-slope or Groundspeed
HSI	.....Horizontal Situational Indicator
ICA	.....Instructions for Continued Airworthiness
IFR	.....Instrument Flight Rules
IOP	.....Input/Output Processor (Aspen software)
LOC	.....ILS Localizer
LRU	.....Line Replaceable Unit
MAP	.....Main Application Processor (Aspen software)
MOL	.....Maximum Operating Limit
MPS	.....Minimum Performance Standard
OAT	.....Outside Air Temperature
OBS	.....Omni-Bearing Selector
PARAM	.....Parameter
RSM	.....Remote Sensor Module
SEL	.....Select
STC	.....Supplemental Type Certificate
TAS	.....True Airspeed
VFR	.....Visual Flight Rules
VLOC	.....The VOR side of a GNAV radio
WAAS	.....Wide Area Augmentation System

# 1 Introduction

This Installation Manual contains FAA Approved Data, but only when used to install the Aspen Avionics EFD1000 E5 Dual Electronic Flight Instrument (EFI) system in accordance with AML–STC SA10822SC. This document contains detailed instructions for installing the EFD1000 E5 System into specific aircraft as listed in the AML–STC. There are regulations that must be complied with to ensure an airworthy installation. Section 4 –STC Specific Requirements and Limitations and Section 5 –Pre–Modification Planning will guide you through these requirements.

## 1.1 Part Numbers

List of the major hardware components (by part number) that make up the EFD1000 E5 system.

Part Number	Description
910-00101-001	EFD1000 E5, Evolution Flight Display, PMA
910-00005-004	Configuration Module, Assy, TSO
910-00003-002	RSM Rev E or later, Remote Sensor Module, Top Mount, TSO
910-00003-003	RSM Rev E or later, Remote Sensor Module, Bottom Mount, TSO
903-00001-( )	EFD1000 EFD Install Kit, TSO
903-00002-( )	RSM Install Kit, TSO

**Table 1-1: Part Numbers**

Part Number	Description
910-00004-001	ACU, Analog Converter Unit, TSO
903-00003-001	ACU Install Kit, TSO
910-00004-101	ACU2 Analog Converter Unit–HDG Synchro, TSO
903-00003-002	ACU2 Install Kit, TSO
910-00013-001	EA100 Adapter, TSO
903-00011-( )	EA100 Installation Kit, TSO

**Table 1-1A: EFD1000 E5 Optional LRUs**

### 1.1.1 Latest Approved Software Versions

Description	Hardware Component	Software P/N and Revision
EFD1000 E5 Display MAP (Main Application Processor) IOP (Input/Output Processor)	910-00101-001	302-00032-001 MAP Version E5 2.10 302-00033-001 IOP Version E5 2.2
Analog Control Unit (ACU)	910-00004-001	Version 1.1
Analog Control Unit2 (ACU2)	910-00004-10x	Version 2.0
EA100	910-00013-001	Version 1.2

**Table 1-2: Latest Approved Software Version**

1.1.2 AML-STC Document List

The following list of documents contain engineering aspects that are a part of AML-STC SA10822SC data.

Document	P/N	Description
ICA	900-00012-001	Instructions for Continued Airworthiness
AFMS	900-00038-001	Airplane Flight Manual Supplement

Table 1-3: AML-STC Additional Document List

1.2 Installation Kit Contents

Installation Kit, EFD1000 – Basic P/N 903-00001-004		
Part Number	Description	Quantity
403-00002-001	Panel Mounting Bracket Assembly	1
116-00022-002	44 Pin HD D-Sub Connector with Contacts	1
116-00026-006	EMI Metal Backshell	1
275-00001-002	Pitot Quick Connector	1
275-00001-001	Static Quick Connector	1
273-00003-001	Tee Fittings for Pitot/Static, 0.25" x 0.17" x 0.25"	2
271-00001-001	Miniature Hose Clamps	8
412-00004-001	Configuration Module Cable Assembly	1

Table 1-4: 903-00001-() EFD1000 EFD Install Kit

Optional EFD Recess Mount Kit P/N 903-00007-001		
Part Number	Description	Quantity
903-00007-001	EFD Recess Mount Installation Kit (1 required per EFD)	1

Table 1-5: 903-00007-001 EFD Recess Mount Kit (optional)

Installation Kit, RSM P/N 903-00002-()					
Part Number	Description	Quantity by Kit Variant			
		-001	-002	-003	-004
412-00005-001	RSM 35ft cable assembly w/connector	1	1	-	-
412-00006-001	RSM 50ft cable assembly w/connector	-	-	1	1
201-00004-001	Screw, Machined, Pan, Phillips, Brass, 8-32 1 1/4", MS35214-47	4	4	4	4
212-00001-001	Nut, Hex, Locking, Nylon Insert, Brass, 8-32, MS21044B08	4	4	4	4
231-00001-001	Washer, Flat, #8, Brass, 1 1/64" ID, 3/8" OD, NAS1149B0832H	4	4	4	4
256-00001-001	O-Ring, AS568A-120	1	1	1	1
403-00004-001	RSM Doubler Installation Assy	-	1	-	1

Table 1-6: 903-00002-() RSM Install Kits

### 1.3 Optional LRU Install Kits

Installation Kit, ACU P/N 903-00003-001		
Part Number	Description	Quantity
116-00014-001	15 pin D-Sub connector	1
116-00014-002	25 pin D-Sub connector	1
116-00014-003	37 pin D-Sub connector	1
116-00026-002	DB15 EMI Back shell	1
116-00026-003	DB25 EMI Back shell	1
116-00026-005	DB37 EMI Back shell	1
116-00015-001	Crimp Sockets	77

**Table 1-7: 903-00003-001 ACU Install Kit**

Installation Kit, ACU2 P/N 903-00003-002		
Part Number	Description	Quantity
116-00014-001	15 pin D-Sub connector	1
116-00014-002	25 pin D-Sub connector	1
116-00014-003	37 pin D-Sub connector	1
116-00052-001	62 pin high density D-Sub connector, contacts, back shell	1
116-00026-002	DB15 EMI Back shell	1
116-00026-003	DB25 EMI Back shell	1
116-00026-005	DB37 EMI Back shell	1
116-00015-001	Crimp Sockets	77

**Table 1-8: 903-00003-002 ACU2 Install Kit**

Installation Kit, EA100 P/N 903-00011-(-)					
Part Number	Description	Quantity by Kit Variant			
		-001	-002	-003	-004
116-00022-002	44 Pin HD D-Sub connector with contacts	1	1	1	1
116-00026-001	DB 25 EMI Metal Back shell	1	1	1	1
116-00014-001	15 pin D-sub connector	1	1	1	1
116-00026-007	DB15 EMI Back shell	1	1	1	1
116-00015-001	Crimp Sockets	15	15	15	15
122-00031-001	Diode Junction Splice, 200v	2	2	2	2
403-00009-001	Century II/III/IV supplemental parts bag: 2ea. 126-00004-006 Cap 0.12uF, 400V 2ea. 132-00007-002 Resistor 1.21KΩ, 1/4W, 1% 2ea. 132-00007-004 Resistor 2.2KΩ, 1/4W, 1%	1	1	1	1
412-00013-001	EA100 10ft Ethernet Cable	-	1	-	-
412-00013-002	EA100 20ft Ethernet Cable	-	-	1	-
412-00013-003	EA100 30ft Ethernet Cable	-	-	-	1

**Table 1-9: 903-00011-(-) EA100 Install Kits**

1.4 Accessories Required but Not Supplied – EFD1000 E5

Description	Manufacturer's P/N or Specification
Circuit Breaker pull to open (EFD) 7.5 amp	MS 26574-7.5
Circuit Breaker (ACU) 2 amp	MS26574-2
EFD to GPS/ACU double shielded cable	M27500-22TG2V64
Unshielded wire 24, 22, 20 AWG	MIL-W-22759/16
Shielded Wire 22/20 AWG	MIL-C-27500
3/16" pitot/static tube (EFD to T fitting)	MIL-DTL-5593
EFD Mounting Screws #6-32, 6 ea.	MS24693-S30
EFD Mounting Lock Nuts #6-32	MS21044N06
EFD Mounting Washers	NAS1149FN632P
ACU Mounting Screw #8-32	MS35206-XXX
ACU Mounting Lock Nuts #8-32	MS21044N08
ACU Mounting Washers	NAS1149FN832P

Table 1-10: EFD1000 E5 Accessories Required but Not Supplied

1.5 Optional Accessories Not Supplied – EFD1000 E5

Description	Manufacturer P/N or Specification
E5 Master switch -rated for 7.5 amps cont.	MS35058-22 SPST switch
Circuit Breaker/Switch 7.5amp (optional - in lieu of separate C/B and switch)	MS24509-A- 7½
*Tinned Copper Over Braid *used in lieu of double shielded wire	MIL-SPEC# AA59569R36T0250 ¼" MIL-SPEC# AA59569R36T0500 ½"
RSM Doubler	Installer fabricated per Section 6.9.5
RSM Shim (may be required on extreme mounting angles)	Installer fabricated per Section 6.9.9
RSM sealant non-pressure vessel mounting	MIL-A-46146, Dow 738
7 conductor shielded cable For installer fabricated harness using 116-00020-001 connector.	M27500-A24SD7T23/ M27500-22TG7T14

Table 1-11: E5 Optional Accessories Not Supplied

1.6 Optional Accessories Required but Not Supplied – EA100

Description	Manufacturer P/N or Specification
A/P AHRS FAIL press-to-test indicator "dimnable cat's-eye"	Electroswitch Electronic Products MS25041-4 (dimnable) (also available from Aircraft Spruce)
EA100 Ethernet Cable (Cat 5e Ethernet cable (MX100P-24)	Order Aspen Avionics EA100 Installation kits 903-00011-002, -003, or -004 which include the cable.
EA100 Mounting Lock Nuts #8-32 (6)	MS21044N08
EA100 Mounting Washers (6)	NAS1149FN832P
EA100 Mounting Screw #8-32 (6)	MS35206-XXX
Circuit Breaker 2A	MS26574-2

Table 1-12: EA100 Optional Accessories Required but Not Supplied

## 1.7 Special Tools Required

Tool	Manufacturer Part Number	Usage
Positronics crimp tool	9507-0-0-0	All D-Sub
Daniels crimp tool	AFM8	All D-Sub
Positioner	M81969/1-02, K13-1	ACU/ACU2 -J1 /J2/J3, EA100 J1, CG100 J2
Positioner	M81969/1-01, K41	EFD, ACU2 - J4, EA100 J2, CG100 J1
Magnetometer	HMR2300-DEMO-D21-232	RSM Installation

*Table 1-13: Special Tools*

## 1.8 Vendor Information

### Aspen Avionics Inc

5001 Indian School Road NE  
 Albuquerque, NM 87110  
 (505) 856-5034  
[dealersupport@aspenavionics.com](mailto:dealersupport@aspenavionics.com)

### A.E. Petsche Co. (Double Shielded & RSM Cable)

2112 West Division St.  
 Arlington, TX 76012-3693  
 (817) 461-9473  
[Info@aepetsche.com](mailto:Info@aepetsche.com)

### Positronic Industries Inc. (Crimpers/Connectors)

423 N. Campbell Ave.  
 Springfield, MO 65801  
 (417) 866-2322  
[info@connectpositronic.com](mailto:info@connectpositronic.com)

### EDMO Distributors, Inc.

(Wire, Cable)

12830E Mirabeau Pkwy  
 Spokane Valley, WA 99216  
 (800) 235-3300  
[info@edmo.com](mailto:info@edmo.com)

### Wirenetics

(Thermax Cat 5e cable)

27737 Avenue Hopkins  
 Valencia, CA 91355  
 (661) 257-2400  
[itoy@wirenetics.com](mailto:itoy@wirenetics.com)

### Aircraft Spruce

225 Airport Circle  
 Corona, CA 92889  
 877-477-7823  
[www.aircraftspruce.com](http://www.aircraftspruce.com)

## 1.9 Warranty Registration

Registration of LRU part numbers and serial numbers must be recorded. Activating the warranty on the EFD1000 E5 system is just one important aspect of providing a satisfying installation experience for our customers

## 1.10 Regulatory Compliance

### 1.10.1 Technical Standard Order

The RSM, CM, ACU, and EA100 components of the EFD1000 E5 system are produced under Technical Standard Order Authorization (TSOA).

### 1.10.2 PMA Approval

The EFD (Electronic Flight Display) component of the EFD1000 E5 system is approved under Parts Manufacturer Approval (PMA).

### 1.10.3 Software Certification

The EFD1000 E5 system software is approved using system level verification to approve software and show compliance to 23.1309 (and 23.1301) in lieu of RTCA/DO-178/C, in accordance with a Project-Specific Policy Statement dated June 13, 2018.

### 1.10.4 Environmental Compliance

All system components meet the environmental test requirements defined in RTCA/DO-160E as shown in the environmental qualification forms in Section 13.

### 1.10.5 Installation Approval

Installation of the EFD1000 E5 is FAA approved under AML STC SA10822SC. This installation manual contains FAA Approved Data, but only when used to install the Aspen Avionics EFD1000 E5 display system in accordance with this AML STC. The data in this manual may be used only by those authorized to install the EFD1000 E5 in writing, and then only to support installation of the EFD1000 E5, either under STC SA10822SC, or (when FAA-authorized) as a follow-on field approval for aircraft not included in the Approved Model List. Use of this data for any other purpose requires separate written approval from Aspen Avionics Inc.

## 1.11 Field Replaceable Parts

Refer to Appendix D of this manual and the ICA for a list of field replaceable parts.

## 1.12 Reserved

## 2 Equipment Specifications and Limitations

### 2.1 EFD1000 E5

#### 2.1.1 General Specifications

Part Number.....	910-00101-001
Width/Height.....	3.50 in./7.00 in. (Measured at Bezel)
Can Depth.....	4.15 in. (Rear of Bezel to Rear of Can)
Overall Depth.....	6.35 in. (Knob to Rear Pressure Fitting)
Weight.....	2.9 lbs. with bracket
Display Type.....	6.0 in. Diagonal LCD (400x760)
Face.....	Anti-Reflective Coated Glass
Backlight.....	High Intensity White LED
Rotary Knobs.....	Optical Encoder with Momentary Push
Dimming.....	Manual & Automatic (Front Bezel Mounted Sensor)

#### 2.1.2 Operational Specifications

Operating Temp.....	-20°C to +70°C
Storage Temp.....	-55°C to +85°C
Max Operating Altitude.....	35,000 ft. Unpressurized/ 55,000 ft. Pressurized
Cooling.....	Integral Fan
Max Humidity.....	95% at 50°C
Input Voltage.....	+9 to +32 VDC (Note: Input power must transition >11VDC to turn on the unit)
Nominal Current.....	2.4/4.8 Amps (28v/14v)

#### 2.1.3 I/O Specifications

ARINC 429 Inputs.....	2 Low/High Speed
ARINC 429 Outputs.....	1 Low/High Speed
RS-232 Inputs.....	2
RS-232 Outputs.....	3
Pitot/Static.....	Quick Connect

#### 2.1.4 Certification Specifications

FAA-PMA

2.1.5 EFD1000 E5 Outline Drawing

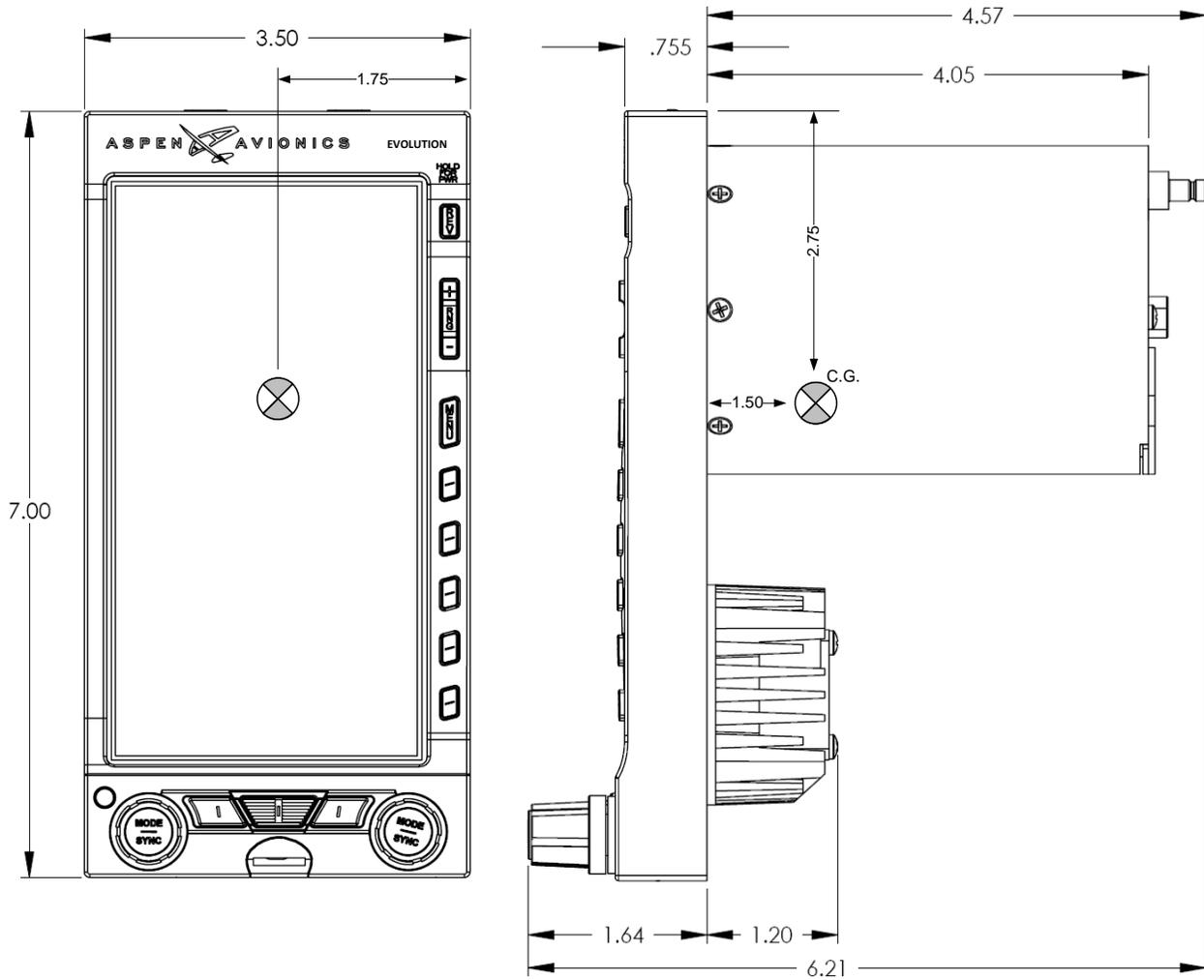

Figure 2-1: EFD1000 E5 Outline Drawing (inches)

2.1.6 Design Eye Viewing Envelope

The following information defines the viewing envelope within which the EFD1000 E5 complies with the equipment standards.

**Minimum and maximum distance from the center of the EFD display surface:**

10 inches (25.4 cm) minimum to 45 inches (114.3 cm) maximum.

**Total viewing angles:**

From  $-30^\circ$  to  $+30^\circ$  (left/right), and  $+30^\circ$  to  $-30^\circ$  (top/bottom) perpendicular to the EFD front glass surface.



2.2.5 Outline Drawing:

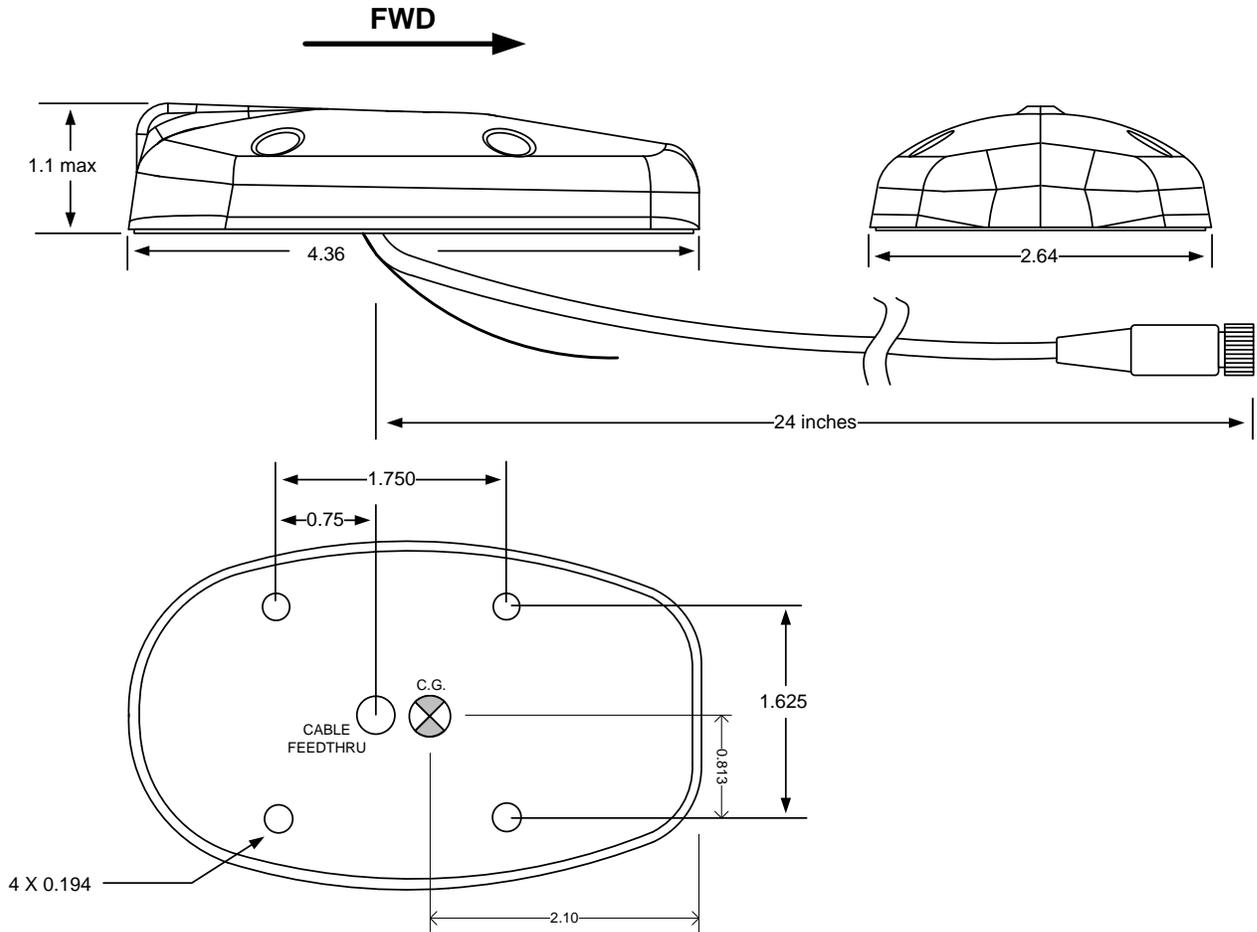

Figure 2-2: RSM Outline Drawing (inches)

2.3 Configuration Module (CM)

There is a single hardware part number Configuration Module, which is then loaded with the appropriate configuration settings image file that establishes the functionality and feature set of the attached EFD1000 E5 system.

2.3.1 General Specifications

Part Number .....	910-00005-004
Width .....	1.0 in.
Height .....	0.55 in.
Length.....	1.85 in.
Weight.....	0.1 lbs.

**2.3.2 Operational Specifications**

Operating Temp ..... -20°C to +70°C  
 Storage Temp..... -55°C to +85°C  
 Max Operating Altitude ..... 35,000 ft. Unpressurized/ 55,000 ft. Pressurized  
 Cooling ..... None Required  
 Max Humidity..... 95% at 50°C  
 Input Voltage..... Provided by EFD  
 Nominal Current..... Included in EFD Current

**2.3.3 I/O Specifications**

Proprietary Digital

**2.3.4 Certification Specifications**

The Configuration Module is certified as a component of the EFD1000 E5 system

*Software:* NONE

*Complex Electronic Hardware (CEH):* NONE

*Environmental:*

RTCA DO-160E ..... See Environmental Qualification Form Section 13

**2.3.5 Outline Drawing**

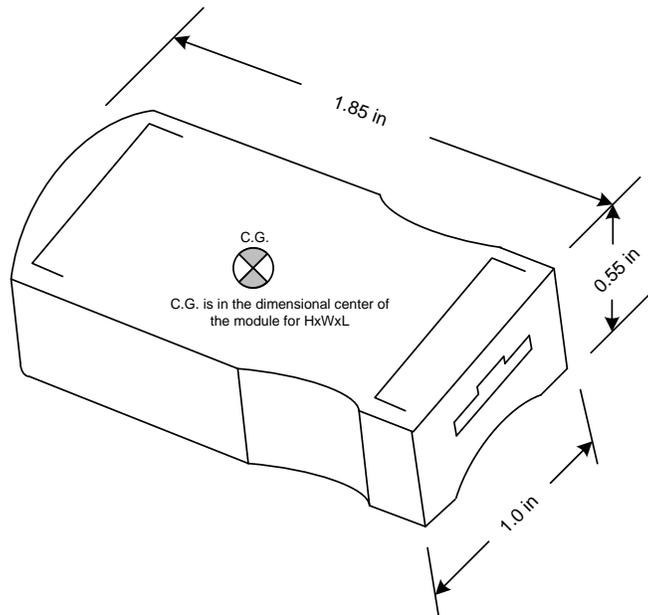

**Figure 2-3: Configuration Module Outline Drawing (inches)**

**2.4 Analog Converter Unit (ACU)**

**2.4.1 General Specifications**

Part Number ..... 910-00004-001  
 Width ..... 5.75 in. including mounting flanges  
 Height ..... 1.60 in.  
 Length ..... 4.28 in.  
 Weight ..... 0.8 lbs.

**2.4.2 Operational Specifications**

Operating Temp ..... -40°C to +55°C  
 Storage Temp ..... -55°C to +85°C  
 Max Operating Altitude ..... 35,000 ft.  
 Cooling ..... None Required  
 Max Humidity ..... 95% at 50°C  
 Input Voltage ..... +11 to +32 VDC  
 Nominal Current ..... 0.5/1.0 Amps (28v/14v)

**2.4.3 I/O Specifications**

ARINC 429 Inputs ..... 2 Low Speed  
 ARINC 429 Outputs ..... 2 Low Speed  
 RS-232 Inputs ..... 1 (software loading only)  
 VHF Nav Receiver ..... 1 Analog input  
 GPS Receiver ..... 1 Analog input  
 GPS OBS Interface ..... 1 Output  
 Autopilot Interface ..... 1 Analog port

**2.4.4 Certification Specifications**

The ACU is certified as a component of the EFD1000 E5 system

*Software:*

RTCA DO-178B ..... Level C

*Complex Electronic Hardware (CEH):* NONE

*Environmental:*

RTCA DO-160E ..... See Environmental Qualification Form Section 13

2.4.5 Outline Drawing:

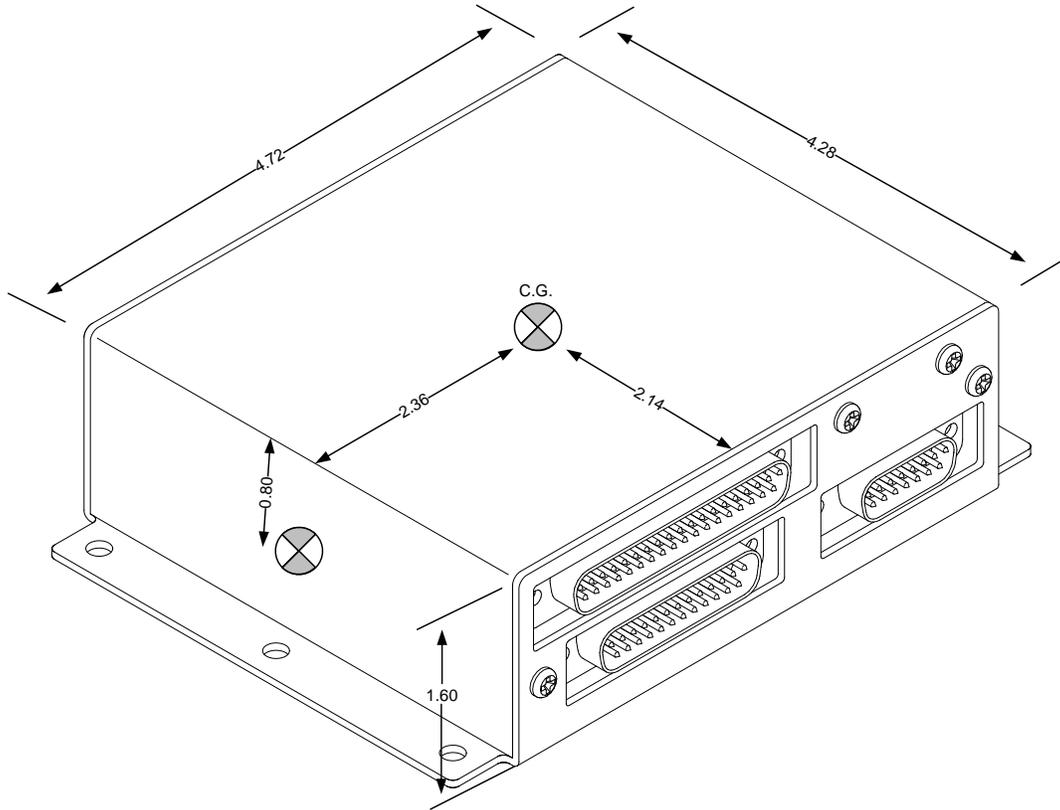

Figure 2-4: ACU Outline Drawing (inches)

2.5 Analog Converter Unit 2

2.5.1 General Specifications

- Part Number ..... 910-00004-101, -102
- Width ..... 5.75 in. including mounting flanges
- Height ..... 2.25 in.
- Length ..... 4.28 in.
- Weight ..... 1.1 lbs.

2.5.2 Operational Specifications

- Operating Temp ..... -40°C to +55°C
- Storage Temp ..... -55°C to +85°C
- Max Operating Altitude ..... 35,000 ft.
- Cooling ..... None Required
- Max Humidity ..... 95% at 50°C
- Input Voltage ..... +11 to +32 VDC
- Nominal Current ..... 0.5/1.0 Amps (28v/14v)

2.5.3 I/O Specifications

- ARINC 429 Inputs ..... 2 Low/High Speed
- ARINC 429 Outputs ..... 3 Low/High Speed

- RS-422..... 2 Transmitters
- RS-422..... 2 Receivers
- RS-232 Input..... 1 (software loading only)
- VHF Nav Receiver..... 1 Analog input
- GPS Receiver..... 1 Analog input
- GPS OBS Interface ..... 1 Output
- Autopilot Interface..... 1 Analog port
- G/S and NAV Flag to A/P ... low level (-101), Discrete to drive Superflag (-102)
- Heading Synchro ..... 1 Output with 26Vac Reference

**2.5.4 Certification Specifications**

The ACU2 is certified as a component of the EFD1000 E5 system

*Software:*

RTCA DO-178B ..... Level C

*Complex Electronic Hardware (CEH):* NONE

*Environmental:*

RTCA DO-160E ..... See Environmental Qualification Form Section 13

**2.5.5 Outline Drawing**

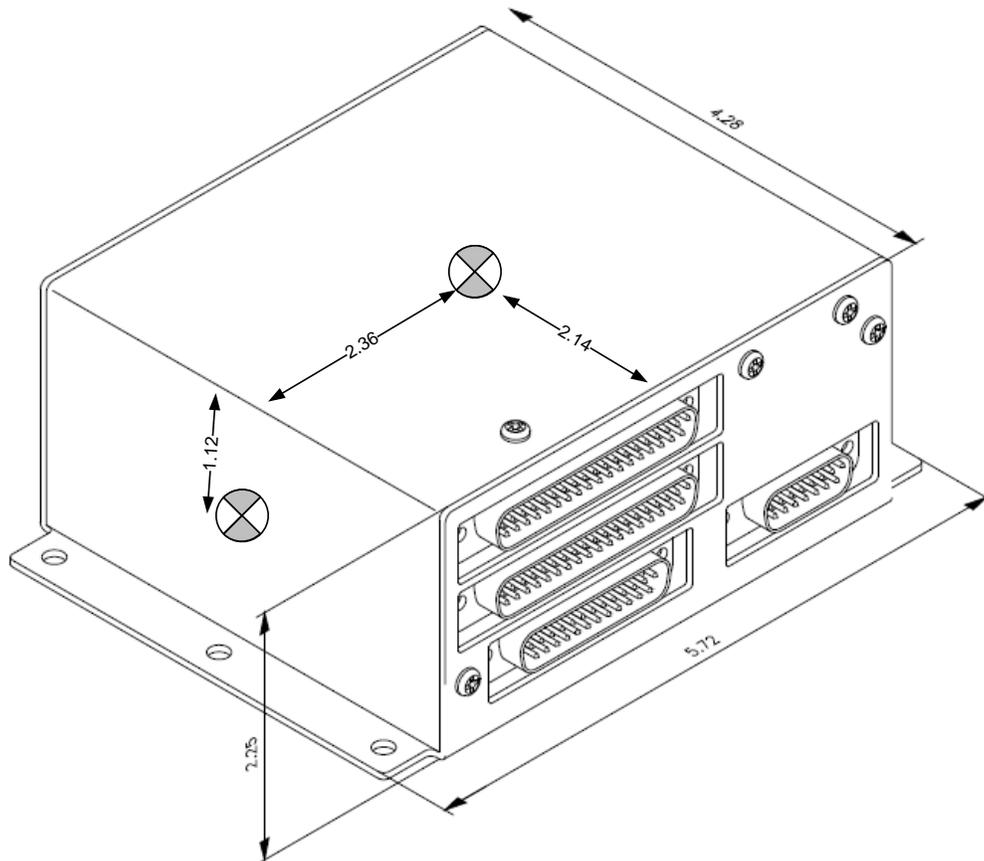

**Figure 2-5: ACU2 Outline Drawing (inches)**

## 3 System Description

### 3.1 EFD1000 E5 Dual Electronic Flight Instrument (EFI) system

The EFD1000 E5 contains an internal ADAHRS that is used to provide attitude, heading and air data for the display. The EFD1000 E5 comes standard with an internal battery to provide 30-minute operation in the event of power loss

Additional equipment is normally installed in support of the displays, including the Remote Sensor Module (RSM), Configuration Module (CM), EA100 and optional Analog Converter Unit (ACU). An external GPS receiver is required for IFR but is optional for airplanes restricted to VFR. Optionally a remote VOR navigation receiver may be connected.

The EFD1000 E5 provides display of attitude, airspeed, altitude, direction of flight, vertical speed, turn rate, and turn quality. The system can provide display of navigation information, pilot-selectable indices (“bugs”), and annunciations to increase situational awareness and enhance flight safety.

### 3.2 EFD1000 E5 Flight Display (EFD)

The EFD1000 E5 (EFD) display is a digital system that consists of a high-resolution 6” diagonal color LCD display, user controls, photocell and Micro SD data card slot. The rear portion of the EFD includes a non-removable electronics module that contains a full air data computer, attitude heading reference system, power supplies, internal battery, and dual processor electronics. Also on the rear of the unit, a fan is provided to cool the backlight and electronics.

The EFD mounts to the front surface of most instrument panels. The electronics module and cooling fins on the back are sized to fit into existing instrument panel holes. A recess-mount bracket is available to mount the displays nearly flush with the instrument panel.

The mechanical design allows the instrument to be installed in a vertically oriented pair of instrument openings, without interfering with the surrounding instruments. The installation requires minimal mechanical modifications to most general aviation aircraft instrument panels. The EFD contains a microSD card port and reader at the bottom of the display bezel. When authorized, software updates and system upgrades can be installed using the card port. This is a maintenance action that is accomplished by authorized maintenance personnel.

The EFD is a digital system and supports both ARINC 429 and RS-232 digital interfaces. In installations with a modern digital radio installation, the display connects directly to the interfaced equipment.

In installations that require interfaces to analog avionics (i.e., older VLOC navigation radios and autopilots) an optional ACU is required to digitize the analog signals into ARINC 429.

### 3.3 Remote Sensor Module (RSM)

The RSM is required and connects directly to the EFD display. It physically resembles a traditional GPS antenna and follows the industry standard mounting hole pattern.

The RSM contains all of the sensors that must be remotely located from the EFD display unit.

The RSM is powered by the EFD through a shielded wire harness and contains the Magnetic “flux” sensors.

All RSM versions must be mounted in a magnetically quiet environment. The -002 RSM may be mounted internally within the fuselage or wing structure or externally on the fuselage. The -003 bottom mount RSM can be mounted internally in the upside down orientation or externally on the underside of the aircraft. The -001 RSM is eligible for installation.

***CAUTION: Do not mount an RSM made for inverted operation on the top of the aircraft as reverse magnetic sensing will result, producing unacceptable AHRS performance.***

### 3.4 Configuration Module (CM)

The Configuration Module retains system configuration settings and calibration data. The Configuration Module connects to the EFD through a short, fabricated, harness and is fastened to the main wiring bundle of the display.

Each display has an associated Configuration Module that retains that display’s aircraft specific configuration, calibration data and user settings. This scheme permits the display hardware to be replaced without re-entering the installation settings or re-calibrating the EFD.

### 3.5 Analog Converter Unit (ACU)

The optional Analog Converter Unit (ACU) provides compatibility with older, analog-based avionics when required. The ACU converts and concentrates multiple analog interfaces to digital signals supported by the EFD. Control parameters, such as desired heading and selected course, are also sent from the EFD to the ACU for conversion to analog format for autopilot support.

The ACU is required when any of the following capabilities are required:

- Interface to supported autopilots
- Interface to supported non-ARINC 429 VLOC navigation radios
- Interface to supported non-ARINC 429 GPS navigators

If digital radios (i.e., Garmin 4XX/5XX and similar series radios) are equipped in the aircraft and no other aircraft interfaces are to be used, then the ACU is not required.

### 3.6 Analog Converter Unit 2 (ACU2)

The optional ACU2 provides all the features of the standard ACU above but adds the following capabilities:

- Heading Synchro (bootstrap) output to drive ancillary equipment that requires an ARINC 407 analog heading input.
- High Speed A429 data output when required.

### 3.7 System Architecture

The system architecture in Figure 3-2 shows the relationships of the EFD1000 E5 with its associated RSM, Configuration Module and optional ACU and EA100.

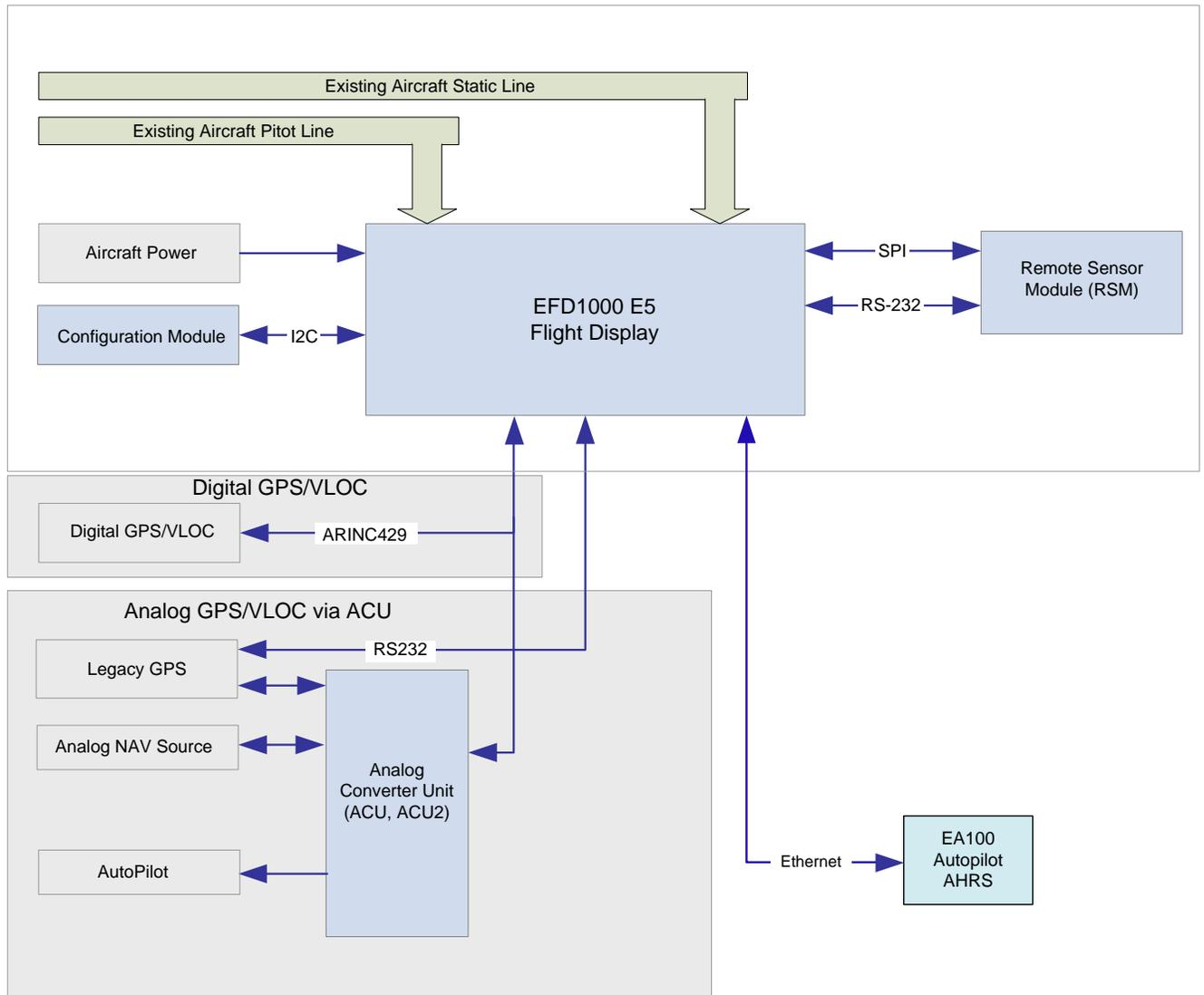

Figure 3-1: EFD1000 E5 System Architecture

THIS PAGE IS INTENTIONALLY LEFT BLANK

## 4 STC Specific Requirements and Limitations

### 4.1 EFD1000 E5 System Limitations

This section contains requirements that must be considered before installing the EFD1000 E5 system.

A turn and slip indicator (or backup attitude indicator) and an IFR GPS are always required for airplanes certified for IFR operation. For airplanes restricted to VFR, see Section 4.5, Special Consideration for Aircraft Limited to VFR.

The EFD1000 E5 is not approved for aircraft with a maximum takeoff weight (MTOW) exceeding 6000lbs.

This installation is not authorized as a Flight Display for Category II Operations or RVSM Operations.

### 4.2 EA100 Installation Limitations (EA100 is optional)

- The EA100 must be installed in a temperature-controlled part of the aircraft.
- The EA100 must not be installed on the firewall.
- Maximum Ethernet cable length between the EFD and the EA100 is 30 feet.
- An “A/P AHRS FAIL” light (amber) must be installed in the pilot primary field-of-view.
- AFMS 900-00038-001 Rev ( ) or later FAA approved revision with the Configuration Matrix in Section 1.2 completed must be inserted in the Airplane Flight Manual.

### 4.3 Authorized Configurations

The following are authorized configurations of the Aspen EFD1000 E5:

## IFR Approved Configuration

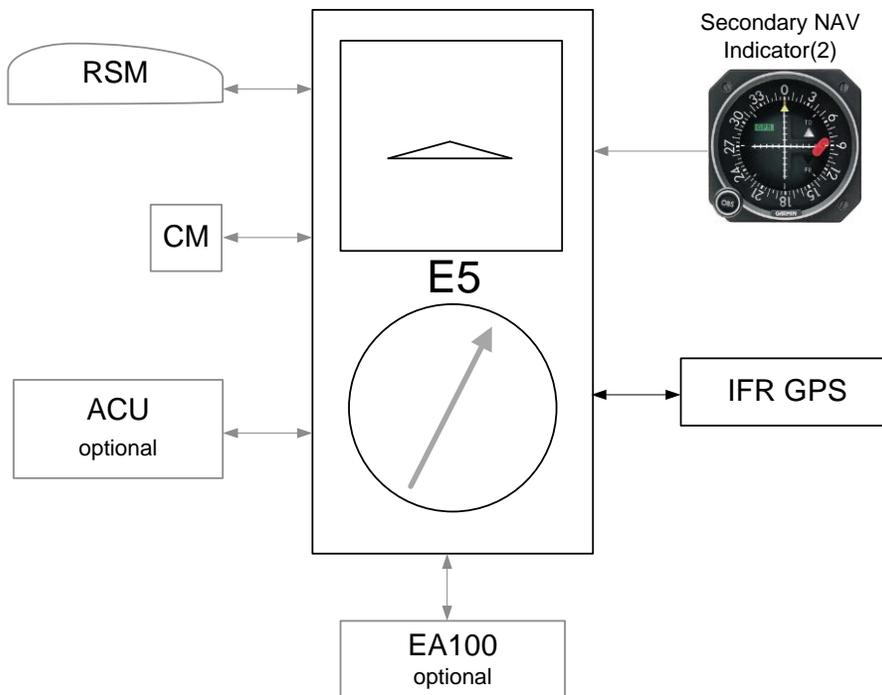
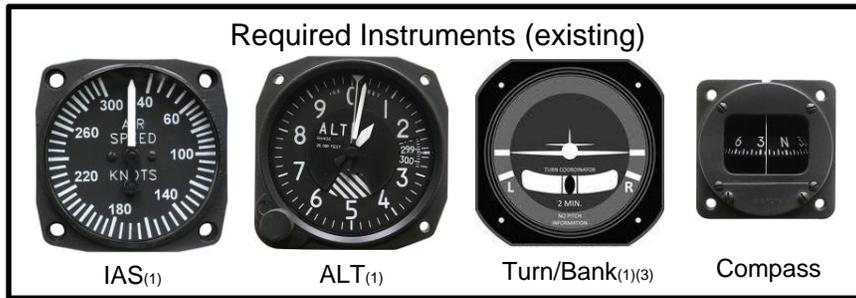

**Requires:**

- existing Altimeter(1)
- existing Airspeed indicator(1)
- existing Turn/Bank indicator(1)(3)
- Magnetic Direction Indicator (compass)
- Secondary navigation indicator(2) (when required - see section 4.4.5)
- IFR GPS navigator input (see Section 5 table 5-2 for compatible devices)

(1) - The airspeed, altimeter and turn/bank indicators of the E5 are secondary (advisory) functions. These existing instruments must not be removed or relocated.

(3) - The Turn/Bank indicator may be removed provided an acceptable backup Attitude indicator is installed.

**Figure 4-1: EFD1000 E5 Authorized IFR Configuration**

## VFR with Standby Instruments

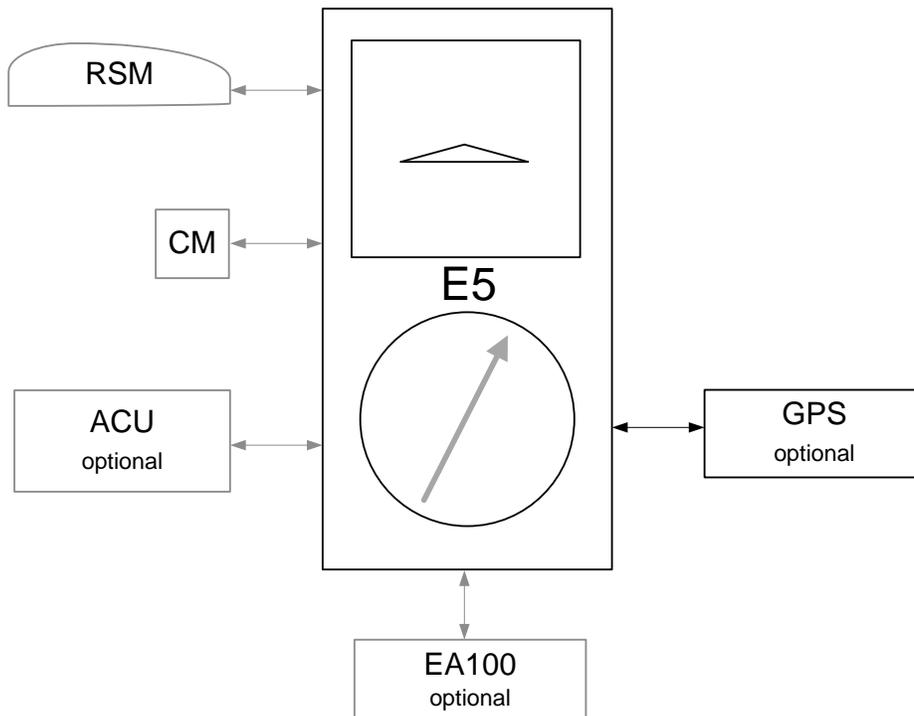

**Requires:**

- existing Altimeter(1)
- existing Airspeed indicator(1)
- Magnetic Direction Indicator (compass)(1)

(1) -These existing instruments must not be removed or relocated.

**Figure 4-1A: EFD1000 E5 Authorized VFR with Backups Configuration**

## 4.4 General Standby Instrument Requirements for IFR–Capable Airplanes

The EFD1000 E5 flight display presents various indicators of attitude, altitude, airspeed, vertical speed, rate of turn and slip skid. The existing aircraft also has these indicators. Only the attitude indicator on the EFD1000 E5 is a primary instrument. The EFD1000 E5 displays of airspeed, altitude, vertical speed, rate of turn and slip skid are all secondary displays and the existing indicators remain the primary. For this reason, the existing instruments may not be removed or relocated under this STC. The exception is that the existing turn/bank indicator may be removed if it is replaced with a backup attitude indicator.

The existing magnetic direction indicator “whiskey compass” may not be removed during the installation of the EFD1000 E5 system.

***WARNING:*** *Failure to adhere to these specific instrument layout requirements and EFD1000 E5 configuration requirements and limitations will violate the STC.*

### 4.4.1 Pneumatic Attitude (existing)

The existing attitude indicator may be removed unless it is required for autopilot or flight director purposes. It may also be retained and used as the secondary source of attitude if it is desired to remove the turn and slip indicator or turn coordinator.

Removal of pneumatic standby instruments and installation of electric standby instruments is not authorized by this STC. Separate installation approval would be required.

Changing the vacuum source of the AI is beyond the scope of the STC and must be separately approved.

### 4.4.2 Electric Attitude (existing)

The existing attitude indicator may be removed unless it is required for autopilot or flight director purposes. It may also be retained and used as the secondary source of attitude if it is desired to remove the turn and slip indicator or turn coordinator.

The E5 contains an internal battery that maintains power for 30 minutes under all foreseeable operating conditions. No battery backup required on the electric Attitude indicator or turn and slip indicator or turn coordinator.

The installation of dual independent electrical systems or a standby (emergency) aircraft battery is not authorized by this STC. Separate installation approval would be required.

### 4.4.3 Existing Attitude Positioning (if keeping)

The position of the existing Attitude Indicator will depend on whether the turn and slip indicator is being retained or removed.

**Turn and Slip or Turn Coordinator Instrument Removed**

If the electric turn and slip indicator or turn coordinator is to be removed, then the existing Attitude indicator must be relocated to the empty turn and slip instrument hole.

*Note: Aircraft with a rate-based autopilot* – the autopilot is using the turn and slip instrument for roll input and therefore this instrument must not be removed.

**Turn and Slip or Turn Coordinator Instrument Retained**

**No Flight Director display** – The existing attitude indicator if used as an attitude source to the autopilot (no flight director display, and no EA100 installed) may be repositioned to any position in the instrument panel, including the co-pilot side, as the turn and slip or turn coordinator is retained in its original location as part of the backup attitude solution.

**Flight Director display** – If the existing attitude indicator includes a flight director display then it must be relocated to a position within the pilot’s primary maximum field of view in accordance with FAR 23.1321(a). The requirements are  $\pm 35$  degrees from the pilot’s centerline horizontally ( $\pm 21$  inches from centerline as defined by AC 23-1311-1b) to an area just below the basic T configuration to the glare shield vertically (see Figure 4-2 below). The EFD1000 E5 does not display flight director information.

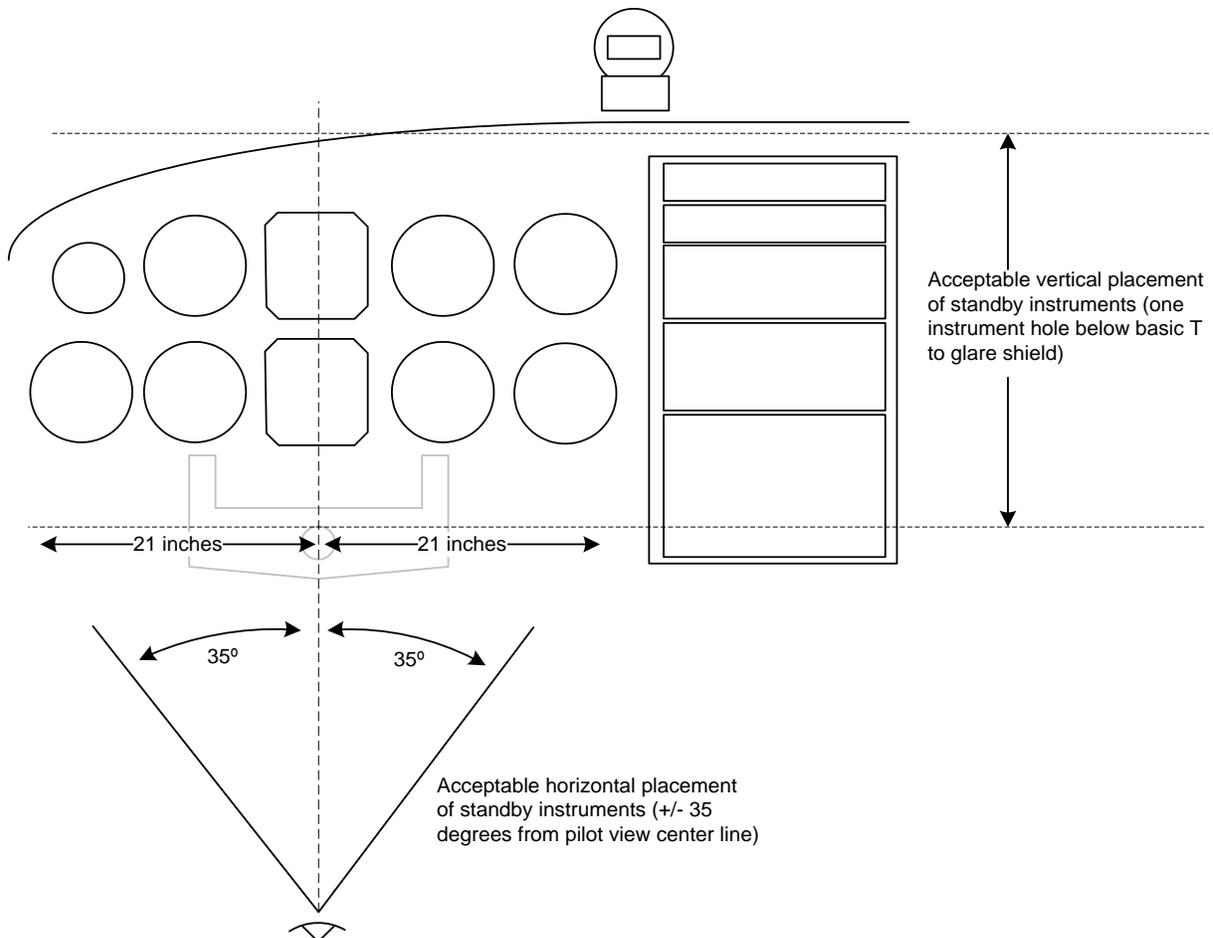

**Figure 4-2: Flight Director/Backup Nav/Placard placement**

#### 4.4.4 Airspeed and Altimeter

The existing airspeed and altimeter must remain in the original certified positions (basic T configuration). Relocation is not approved under this STC.

The EFD1000 E5 should be connected to an independent pitot and static line (independent of the existing pneumatic airspeed and altimeter) whenever available.

***WARNING:*** Failure to adhere to these specific instrument layout requirements and EFD1000 E5 configuration requirements will invalidate the STC.

#### 4.4.5 Back Up Nav Indicator

For certification reasons a backup navigation indicator is required for at least one type of operation for which the aircraft is certificated. This means that in any installation in an aircraft certified for IFR where the EFD1000 E5 is the only display of navigation information in the cockpit, a backup navigation indicator is required. This will ensure that a failure of the EFD1000 E5 system does not result in a complete loss of all navigation data to the flight crew.

Thus, for example, an installation that includes a panel mount GPS with an integral LCD display that includes a CDI indicator approved for navigation would not require a backup NAV indicator. However, a GPS with legacy VLOC radio that does not include an integral display with CDI indications approved for navigation will require a backup NAV indicator.

If there is already a dedicated indicator wired to an existing NAV Receiver or GPS then it can be paralleled to the ACU as shown in Section 9.

***WARNING:*** Failure to provide a backup NAV indicator when required will invalidate the STC.

##### ***CNX-80/GNS480***

It is not recommended that a backup NAV indicator be connected. If it is desired to connect a backup navigation indicator then it should only be wired to the dedicated VOR Composite output on connector P7 of the CNX/GNS. Connecting the NAV indicator to the AUX CDI output on P5 or to the Main Course Deviation output is not recommended.

#### 4.4.6 Placards

All placards must be of a material that is not easily erased, disfigured, or obscured, and securely adhered to the instrument panel.

The following placard is required and must be located near the EFD1000 E5 within the pilot's maximum field of view (see Figure 4-2). The placard must be in black and white (white letters on black background or black letters on white background) in a font no smaller than other placards in the aircraft and reads as follows:

**ON BAT Dispatch Limit is 80%  
See EFD1000 E5 AFMS**

If there are two GPS or two VLOC receivers installed in aircraft, label the GPS connected to the EFD1000 E5 as "GPS1" and if a VLOC receiver is connected label as "VLOC1".

## 4.5 Special Consideration for Airplanes Limited to VFR

The following requirements must be met in order to install the EFD1000 E5 in Part 23 airplanes limited to VFR in accordance with this STC:

1. If the airplane is certified for IFR, obliterate the portion of the cockpit placard that permits IFR operation.
2. Permanently affix a placard in full view of the pilot, stating "Operation of This Aircraft is Limited to VFR Only" in the same location as the obliterated statement or near the EFD1000 E5, in the same font size as the other placards in the cockpit.

Use the following method to install the EFD1000 E5 in an aircraft limited to VFR:

The EFD1000 E5 must be installed with standby Altimeter, standby Airspeed indicator, and whiskey Compass installed in their original locations. See Figure 4-1A.

Note - The placard required under section 4.4.6 is not required for airplanes limited to VFR.

## 5 Pre-Modification Planning

**NOTE:** The installer must provide the aircraft operator with copies of wiring diagrams (copy from Section 9 and/or draft ones not shown) and equipment locations (completed Figure 1 in the ICA) that are suitable for system troubleshooting.

### 5.1 Pre-Modification Checklist

Complete table 5-1 to ensure that the aircraft to be modified is a suitable candidate for installation of the EFD1000 E5 system using this AML-STC. It is required to have a PASS or NA for all rows in order to use this AML-STC as the certification basis for the EFD1000 E5 installation. NA means Not Applicable because no interface is made to that device. Only Items designated with “- NA if no” (i.e. Items 4, 5, 8, and 10) may use NA in the PASS column.

Pre-Modification checklist for EFD1000 E5		
ITEM	CRITERIA	PASS
1	Is the aircraft to be modified on the Approved Model List (AML)?	
2	Does aircraft have sufficient electrical capacity to supply all required equipment given the current draw in Table 7-1?	
3	Is there acceptable clearance between the control column (yoke or stick) and the E5 when the flight controls are in the full nose down position.	
4	Aircraft with Flight Director (FD) displays - Is there an acceptable location to relocate the existing FD Indicator (see section 4.4.3) in the pilot’s field of view? (see Figure 4-2). -NA if no flight director.	
5	Is a backup navigation indicator required (see section 4.4.5) - NA if no Backup NAV indicator is required. If a backup indicator is required, is there an acceptable location to mount or relocate a required backup NAV Indicator in the pilot’s field of view? (see Figure 4-2)	
6	Is there an acceptable location to mount the RSM? (see Section 6.9)	
7	Is there a location to mount the necessary circuit breakers that will be accessible to the pilot while seated?	
8	Are there suitable locations to mount the necessary switches that are accessible to the pilot while seated? - NA if not installed.	
9	Does the aircraft have a compatible GPS receiver, or will one be installed? (see Table 5-2)	
10	If the aircraft is equipped with an autopilot - is the Autopilot compatible? (see Electrical Interface Section 8 to determine heading and nav compatibility, and Appendix E to determine EA100 compatibility- NA if no autopilot interface.	
11	If the aircraft is limited to VFR, is there a placard stating “Operation of This Aircraft is Limited to VFR Only”, The statement must be located in full view of the pilot, stating “Operation of This Aircraft is Limited to VFR Only” in the same location as the removed IFR statement or near the EFD1000 E5, in the same font size as the other placards in the cockpit.	
12	Verify RSM is P/N 910-00003-002 or -003 Rev E or later. Rev D or earlier RSM’s not approved with EFD1000 E5 system.	
13	The EFD1000 E5 Display does not display any GPS annunciations. Make sure no required GPS annunciations are removed during the EFD1000 E5 installation.	

**Table 5-1: Pre-Modification Checklist**

### 5.1.1 Directional Gyro/ HSI

The EFD1000 E5 Flight Display will replace the existing Directional Gyro or HSI in the panel. If another device is “bootstrapped” from the compass then it will need to be determined whether RS-232 or LS ARINC 429 heading is accepted by this device and rewired appropriately. If the other device only accepts ARINC 407 synchro heading or HS ARINC 429 then an ACU2 will be required.

A magnetic direction indicator is required as a secondary direction indicator per FAR 23.1311(a)(5).

***NOTE – If removing an HSI instrument for an airplane approved for IFR, the installer must verify that no required navigation capability is being lost by its removal.***

### 5.1.2 Aircraft Power Requirements

An electrical load analysis must be performed to ensure the installed EFD1000 E5 components do not exceed the current capacity of the aircraft’s charging system (see Section 7.1).

The EFD1000 E5 system uses an internal battery to permit operation of the EFD1000 E5 during an aircraft charging system failure. If the aircraft bus voltage falls below a nominal 12.3V (14V electrical system) or 24.6V (28V electrical system), and the indicated airspeed is above 30 knots or mph (as configured), the EFD1000 E5 will switch to the internal battery. The installer must ensure that the aircraft electrical system attains the minimum voltage when the electrical system is loaded to flight configuration and engine RPM is at or above the level necessary for nominal alternator/generator output.

### 5.1.3 Equipment Power Requirements

A switch or switch breaker to the EFD must be installed. This switch is used during emergency procedures, and also enables the EFD to remain off during engine start.

When not using a switch style circuit breaker, each circuit breaker(s) must be a trip free pull type and must be connected to the main battery bus (after the Battery Master Switch) as shown in the EFD1000 E5 wiring diagram. Do not connect to the Avionics Bus.

If available, connect the ACU/ACU2 to the avionics electrical bus. Otherwise, connecting the ACU to the switched battery bus is permissible.

### 5.1.4 Reserved

### 5.1.5 Cessna 190/195 Special Consideration

Some Cessna 190/195 aircraft have non-standard airspeed indicators that cannot be replaced by standard airspeed indicators. Therefore, when used in aircraft with non-standard airspeed systems, the EFD1000 E5 airspeed tapes must be “locked off” in the EFD1000 E5 installation menus so the pilot always uses the non-standard airspeed indicator.

Most Cessna 190/195 aircraft with a standard (“L”)-shaped pitot mast use standard airspeed indicators. Cessna 190/195 aircraft with a “Harpoon”-shaped pitot mast do not have a standard airspeed indicator.

Review of the logbooks and technical data must be accomplished to verify that the airspeed indicator is standard or not. Generally, unless modified, aircraft serial number 16084 and above have standard airspeed indicators, and 16083 and below do not.

The pitot and static systems must still be connected to the EFD1000 E5 because these inputs are used in the EFD1000 E5 for other purposes.

***CAUTION:*** *Cessna 190/195 aircraft using non-standard airspeed indicators must have the EFD1000 E5 airspeed and altitude tapes “locked off” in the installation menus.*

***NOTE:*** *The Pitot and Static system must be connected to the EFD1000 E5 even when the tapes are not to be displayed.*

## 5.2 Reserved

## 5.3 Conventional Landing Gear “tail dragger” Aircraft

The following precautions are necessary for installations in aircraft with conventional landing gear, due to the necessity of initializing the EFD1000 E5 in a tail-down position:

- The RSM must be P/N 910-00003-00x.
- The on-ground heading accuracy of the EFD1000 E5 must be within +/-4 degrees. A RSM shim might be required to meet this tolerance – see Section 6.9.11.

See Section 10.5.1.2 for a conventional gear specific RSM calibration procedure.

## 5.4 Optional Interfaces

### 5.4.1 Autopilot

The EFD1000 E5 with ACU emulates a KI-525A, NSD-360A and PN-101 HSI by providing HDG Datum, CRS Datum, and navigation L/R outputs to a connected autopilot. Any autopilot compatible with the KI-525A, NSD-360A or PN-101 HSI is compatible with the EFD1000 E5 System.

***Note– the E5 does not support flight director display. The existing AI/FD indicator (relocated) must be used for flight director.***

Section 9 of this document shows interconnect diagrams for common autopilots that are compatible with the EFD1000 E5. Because the EFD1000 E5 outputs Heading Datum and Course Datum via the ACU the existing HSI/DG is no longer required to provide this output to the autopilot.

When the EFD1000 E5 System is installed, the ACU controls all analog navigation signals provided to the autopilot. Navigation signal output to the autopilot is switched depending on which sensor is coupled to the EFD1000 E5 display. Therefore, the LT/RT/UP/DN, flags, and ILS Energize must only be connected between the ACU and autopilot, and there should be no direct connection between the navigation receiver and the autopilot.

#### 5.4.1.1 EA100 Adapter

See Appendix E for detailed EA100 installation eligibility. The EA100 can only be used to replace the analog outputs from the attitude indicators and autopilots identified in Appendix E. No other autopilot interfaces are authorized. KFC250 autopilots must have the P/N 065-5016-XX Adapter Board to be eligible for connection to the EA100.

### 5.4.2 GPS Navigator Compatibility

The following table lists the authorized GPS navigators and the type of connection to the EFD1000 E5.

**NOTE: Other GPS navigators have not been evaluated. Contact Aspen Avionics for information regarding additional navigators.**

Navigator	Navigator Mode and/or Type of Connection	EFD1000 E5 Mode and/or Type of Connection
Apollo GX50, GX60, GX65	Standard Mode, RS-232	GPS TYPE 3, RS-232
Avidyne IFD440/540	ARINC 429	ARINC 429
Bendix King KLN 90/A/B, KLN900	Standard Mode, RS-232	GPS TYPE 1, RS-232
KLN 90/A/B	ARINC 429	ARINC 429
Bendix King KLN 94, KLN 89/B	Standard Mode, RS-232	GPS TYPE 1, RS-232
Bendix King KLN94 "Enhanced Mode"	Enhanced Mode, RS-232	GPS TYPE 2, RS-232
Bendix King KSN 770	ARINC 429	ARINC 429
Garmin GPS155, GPS155XL GPS300XL, GNC300, GPS165	ARINC 429	ARINC 429
Garmin GNS-4xx/5xx GTN-6xx/7xx	ARINC 429	ARINC 429
Garmin GNS-4xx/5xx GTN-6xx/7xx	RS-232	This configuration should not be used.
Garmin GNS-480 (Software v2.0 and below)	ARINC 429	This configuration should not be used.
Garmin GNS-480 (Software v2.3)	ARINC 429 GAMA 429 GFX Int	ARINC 429

**Table 5-2: GPS Compatibility**

### 5.4.3 GPSS

GPS Steering provides a steering command to the autopilot through the HDG Datum channel to provide for enroute, procedure turn, holding pattern, and turn anticipation operation. GPSS through the EFD1000 E5 is only available if Label 121 is transmitted by the GPS over the ARINC 429 bus and the optional ACU is installed.

### 5.4.4 GPS/ NAV Switching

Existing GPS/NAV switching from the GPS and VLOC receiver to the original HSI or Nav indicator will be removed as the EFD1000 E5 will provide this capability. The existing GPS and VLOC receiver will be wired directly to the EFD or ACU as per the installation drawings in Section 9. Analog connections from the GPS and/or VLOC receiver to the autopilot will be removed and wired per the ACU to autopilot interfaces shown in Section 9.

**CAUTION – Do not remove any required GPS annunciation on the external NAV/GPS switch assembly as the EFD1000 E5 does not support any GPS annunciation (i.e., WPT, APPR, TERM, INTEG).**

### 5.4.5 Heading Output

Magnetic heading is available in the following formats:

Heading Type	Sources
ARINC 429 Low Speed	ACU (P3 pins 4/5)
	ACU2 (P3 pins 4/5)
	EFD1000 E5 (pins 26/27)
ARINC 429 High Speed	ACU2 (P3 pins 4/5)
	EFD1000 E5 (pins 26/27). <i>Can only be used with ACU2 or no ACU.</i>
RS-232 (Format C and Z)	EFD1000 E5 (pins 13,14,15)
Synchro (ARINC 407)	ACU2 (analog) includes XYZ synchro out, 26Vac Ref out <sup>(1)</sup> , and valid

**Table 5-3: Heading Sources**

**(1)NOTE:** *The ACU2 26Vrms@400hz reference output can support loads up to 0.06VA, which may be one analog or several digital indicators. It is suggested to determine the load requirements of the sources or use an external inverter as the synchro reference.*

### 5.4.6 Air Data Outputs

Air data information is available in the following formats. The ACU does not pass-thru air data information to its output bus, the ACU2 does. See Section 8 for ARINC 429 and RS-232 air data output specifications.

Air Data Type	Sources
ARINC 429 Low Speed	ACU2 (P3 pins 4/5)
	EFD1000 E5 (pins 26/27)
ARINC 429 High Speed	ACU2 (P3 pins 4/5)
	EFD1000 E5 (pins 26/27). <i>Can only be used with ACU2 or no ACU.</i>
RS-232 (Format C and Z)	EFD1000 E5 (pins 13,14,15)

**Table 5-4: Air Data Sources**

#### 5.4.6.1 EFD1000 E5 as Encoding Altitude Source

14CFR 91.217 states in part, a) No person may operate any automatic pressure altitude reporting equipment associated with a radar beacon transponder.

Unless, as installed, that equipment was tested and calibrated to transmit altitude data corresponding within 125 feet (on a 95 percent probability basis) of the indicated or calibrated datum of the altimeter normally used to maintain flight altitude, with that altimeter referenced to 29.92 inches of mercury for altitudes from sea level to the maximum operating altitude of the aircraft.

Aspen has shown that the EFD1000 E5 system is capable of transmitting altitude data reliably on a better than 95% probability basis. Therefore, when the EFD1000 E5 altimeter system is tested and calibrated in accordance with 14CFR 91.413, the EFD1000 E5 system can be used as an Encoding Altitude source.

The EFD1000 E5 provides this output in RS-232 Format Z. See Figure 9-28 for wiring connections.

#### **5.4.7 Flush or Recess Mounting the EFD**

If there is insufficient clearance between an EFD and the control column when the flight controls are in the full nose down position, it will be required to flush mount or recess mount the EFD in the instrument panel. Also the installer may choose to flush mount the EFD for cosmetic reasons.

##### ***Aspen Avionics Flush Mount Kit***

Aspen Avionics offers a specific Flush Mount Kit for this purpose.

##### ***Locally Fabricated Brackets***

If the installer chooses to fabricate their own brackets for flush mounting the displays then this modification is beyond the scope of this manual and will require that the brackets and the instrument panel modification be separately approved.

THIS PAGE IS INTENTIONALLY LEFT BLANK

## 6 Mechanical Installation

The EFD1000 E5 installation will require mechanical modifications to the aircraft. The EFD, RSM and Configuration Module will be installed in all installations, while an optional ACU installed in others. Most installations will require removing and relocating existing flight instruments to alternate locations in the instrument panel.

### 6.1 Unpacking and Inspecting Equipment

Inspect the equipment for evidence of shipping damage. If a damage claim is to be filed save all shipping boxes and packing material to substantiate your claim. To avoid damage to the equipment, do not place the EFD Displays face down on the knobs.

### 6.2 Equipment Location Documentation

It is required by the AML-STC that the EFD, RSM, CM, and ACU mounting locations be recorded in the Instructions for Continued Airworthiness. It is also required that an accurate description of wire and cable routing be noted on the figures. This information will be required later to comply with the ICAs. Make a copy of the form and give to owner for inclusion in permanent aircraft records.

### 6.3 Log Book Entry

Make a logbook entry at the completion of the installation indicating that the aircraft has been modified in accordance with the EFD1000 E5 AML-STC.

### 6.4 Weight and Balance

Using the component weights in Table 6-1 and the moment arm of the component mounting locations perform a weight and balance calculation per AC 43.13-1B Chapter 10. Also account for equipment removed during the modification process.

Component	Weight (lbs.)
EFD1000 E5 with internal battery including bracket	2.9
RSM - Remote Sensor Module	0.5
ACU - Analog Converter Unit (A-05-112-00 or 910-00004-001)	0.8
ACU2 - Analog Converter Unit 2 (910-00004-10x)	1.1
Configuration Module	0.1
EA100	1.25

*Table 6-1: Component Weights*

### 6.5 Mounting Limitations

The following mounting limitations must not be exceeded during the installation of the EFD and RSM.

### 6.5.1 EFD1000 E5 Mounting Limitations (EFD)

- The EFD must be mounted within 20° nose down to -10° nose up of perpendicular to the aircraft waterline.
- The EFD must be mounted within  $0.0 \pm 2.0^\circ$  of the zero degree roll “wings level” axis.

### 6.5.2 RSM Mounting Limitations

- The RSM must be mounted within  $\pm 4^\circ$  to the longitudinal axis of the aircraft (see Figure 6-14)
- The RSM must be mounted within  $\pm 10^\circ$  to the zero degree roll “wings level” axis (see Figure 6-17)
- The RSM must be mounted within  $\pm 10^\circ$  to the zero pitch axis “waterline” of the airframe (see Figure 6-15).
- RSM must be mounted to a relatively flat surface such that when installed it will not deform the aircraft skin and must not allow more than a .030” gap between RSM and skin.
- RSM must not be mounted to a NO ZONE as pictured in Figure 6-11, Figure 6-12, and Figure 6-13.
- Mounting the RSM to, or making other penetrations through, the aircraft pressure vessel is beyond the scope of this STC. Separate FAA approval of pressure vessel penetrations required to accommodate RSM mounting is required prior to the installation of the remaining EFD1000 E5 system components under the EFD1000 E5 AML-STC.
- Mounting the RSM to the exterior of a composite or fabric skinned aircraft structure is beyond the scope of this STC. To mount the RSM on composite or fabric skin aircraft structures, separate FAA approval of the RSM mounting is required prior to the installation of the remaining EFD1000 E5 system components under the EFD1000 E5 AML-STC.

## 6.6 Equipment Bonding

Bond all metal components to the airframe. Prepare bonded surfaces for best contact (resistance of connections should not exceed 0.003 ohm).

The EFD uses an installer fabricated braided bonding strap to ensure proper bonding to the panel. The bond strap is attached with supplied screw (3/8th inch length) to the back of the EFD at a location just below and left of static port. The other end of the strap is attached to the EFD mounting bracket screw at the rear of the panel.

The RSM does not require an RF ground plane, but it must be bonded to the airframe to meet compliance with DO-160E EMI and lightning certification requirements. Bonding of the RSM is achieved through the mounting fasteners. The attached ground wire on the RSM is not a bonding wire but is a shield ground for the pigtail over braid and must be connected to airframe ground. Each RSM harness shield must have its own (i.e. not shared with another RSM) bonding location.

The ACU is bonded through its six (6) mounting holes and chassis when mounted to a metal surface, otherwise a braided or single stranded wire bonding strap to airframe ground will need to be fabricated for mounting on composite structures.

## 6.7 Cooling

The EFD uses an integral fan for cooling. The area near the fan must be unobstructed to permit maximum airflow through the unit. Venting and cooling air circulating behind the EFD will improve heat dissipation and may improve equipment reliability, and is therefore a good installation practice. The RSM, ACU, and Configuration Module have no cooling requirements.

## 6.8 EFD Installation

Mechanical installation of the EFD requires installing the included mounting bracket, connecting a braided bonding strap between the EFD and panel, and installing pitot and static connections to the two keyed quick release pressure fittings.

**NOTE: To avoid damage to the equipment, do not place the EFD Display face down on the knobs.**

### 6.8.1 EFD Mounting Location

The EFD must be mounted approximately centered in the instrument panel per 14CFR 23.1321(d). If the two existing instrument holes that contain the attitude indicator and direction indicator are not exactly centered, but are the closest instruments to the center, then that position is acceptable for mounting the EFD.

The EFD can be mounted on the non-pilot (typically right side) side of the instrument panel if it is not for use by any required pilot during takeoff, initial climb, final approach, and landing. Backup instruments are required on the pilot side only. See 14CFR 23.1311 and 14CFR 23.1321.

**NOTE: Modification to the existing instrument panel is not authorized under this STC. Any modification must be approved separately.**

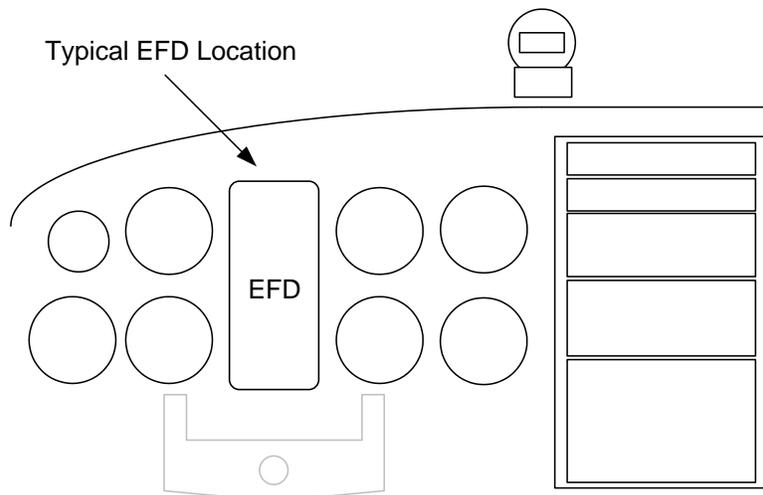

**Figure 6-1: EFD Mounting Location**

### 6.8.2 Surface Mounting the EFD as per Figure 6-2

The pre-drilled holes in the mounting bracket support both standard 3" round instrument holes, and 3ATI square cutouts. The bracket is centered on the upper instrument hole.

The lower portion of the bracket is provisioned with screw slots, allowing variable vertical spacing configurations.

If the lower cutout is a 3ATI or other larger standard cutout, a commercially available metal blanking plate should be used to flush fill the cutout. Use the EFD Mounting Bracket as a template to cut the 2.10" diameter cutout for the fan and two 0.150" diameter mounting holes. All cut edges should be treated to prevent corrosion.

Aircraft with tilted instrument panels of 20° or less can install the EFD flat against the panel. The tilt will later be removed electronically in the system configuration using the Panel Tilt Pitch Adjustment.

The EFD is attached to the instrument panel in 6 places with MS24693-S30 (#6-32 flathead screws), NAS1149FN632P (washers), and MS21044N06 (#6-32 Nuts). It is also acceptable to use existing #6 nutplates.

- 1) Burnish the back of the instrument panel around one of the 6 mounting holes to allow for bracket to instrument panel bonding through the screw/washer/nut.
- 2) Burnish the front side of the instrument panel in 4 locations that line up with the copper EMI fingers of the bracket.
- 3) Loosely install the bracket with the upper two mounting screws/nuts/washers as shown in the figure.
- 4) Use an inclinometer on the top of the EFD bracket with the aircraft level to make this adjustment. It may be necessary to slot the existing holes to align the bracket in the roll axis.
- 5) The EFD must be mounted within  $0.0 \pm 2.0^\circ$  of the zero degree roll "wings level" axis.
- 6) Fabricate an 8" bonding strap from braid and two ground lugs. Attach one ground lug to a mounting screw on the backside of the panel (see Figure 6-10).
- 7) Install remaining EFD mounting bracket screws and nuts.
- 8) Tighten all six (6) mounting screws and nuts to 12 in-lbs. anchoring the bracket to the panel.

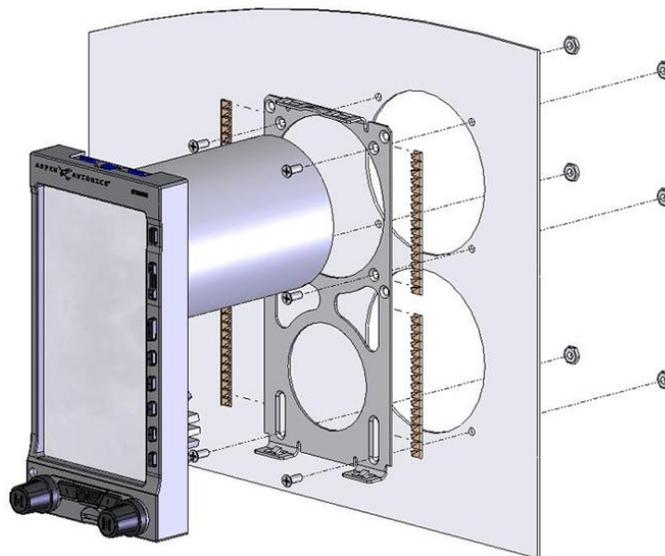

**Figure 6-2: EFD and Bracket Installation**

**6.8.3 Recess Mounting the EFD as per Figure 6-4**

These are partial instructions for accomplishing the aircraft modification to permit recess mounting the EFD1000 E5 displays using Aspen Avionics Recess Mounting Kits. Recess mounting of the EFD displays can be done for cosmetic reasons or for clearance when the flight controls are in the full nose down position. This data, and the information found in AC 43.13-2B Chapters 1, 2 and 11 normally is sufficient data to accomplish the modification.

This section contains instructions for preparing the instrument panel to accept the EFD in a recessed mounting. This data is approved for the structural aspects of the instrument panel modification; however, by itself, it may not be sufficient data to address all aspects of modifying the instrument panel of an aircraft. These instructions and the data in AC43.13-2B chapters 1, 2 and 11 is normally sufficient data to complete the modification. In some cases (for example only, if the instrument panel supporting structure, structural attachments, or a structural instrument panel are modified) then additional data will be required. In those cases where this data is insufficient then these instructions, combined with additional data to accommodate individual differences in an aircraft, can be presented to a Structural DER or Regulatory Authority for approval. If the data package is satisfactory, the DER or Regulatory Authority will approve the data for use in the modification of the instrument panel.

Once all necessary approved data to accomplish the panel mounting is obtained, and the modification is accomplished, the EFD1000 E5 installation can proceed in accordance with AML STC SA10822SC or other regulatory approval process.

One Recess Mounting Kit is required for each EFD display.

Qty	Part Number	Description
1 per EFD	903-00007-001	Recess Mount EFD Installation Kit
4 per EFD	MS24693-S26	6-32 x 3/8" flat head screw, bracket to instrument panel attachment.
1 per EFD	MS24693-S30	6-32 x 3/4" flat head screw, bond strap attachment
1 per EFD	MS21044N06	6-32 Lock Nut, bond strap attachment

**Table 6-2: Parts Required to Recess Mount each EFD**

**6.8.3.1 Recess Mount Modification Procedure**

***STEP 1 - Evaluate the Installation and Determine if Sufficient Approved Data is Available to Proceed***

Normally, the instructions in this section and in AC43.13-2B Chapters 1, 2 and 11 are sufficient data to complete the modification. If the data is not sufficient, such as, for example the instrument panel structural supports are affected or the panel itself provides structural integrity to the airframe, then additional data must be developed and approved. If additional data is required, collect and prepare the approved data necessary to substantiate the alteration before modifying the aircraft.

**STEP 2 – Plan the Cutouts for the Instrument Panel in Accordance with the Cutout Location Figures Below**

Using the dimensions from Figure 6–3 as a guide determine the mounting location of the bracket. Verify that no supporting structure is compromised. See AC43.13–2B.

**STEP 3 – Obtain the Recess Mount Kit**

One Kit is required for each EFD Display.

**STEP 4 – Measure and Mark the EFD Cutout and Bracket Mounting Hole Locations**

Using the dimensions from Figure 6–3 as a guide mark the EFD cutout and four bracket mounting holes.

The clearance notch at the top (see detail “A”) is to permit a tool to be inserted to press the EFD release mechanism and release the EFD from the mounting bracket

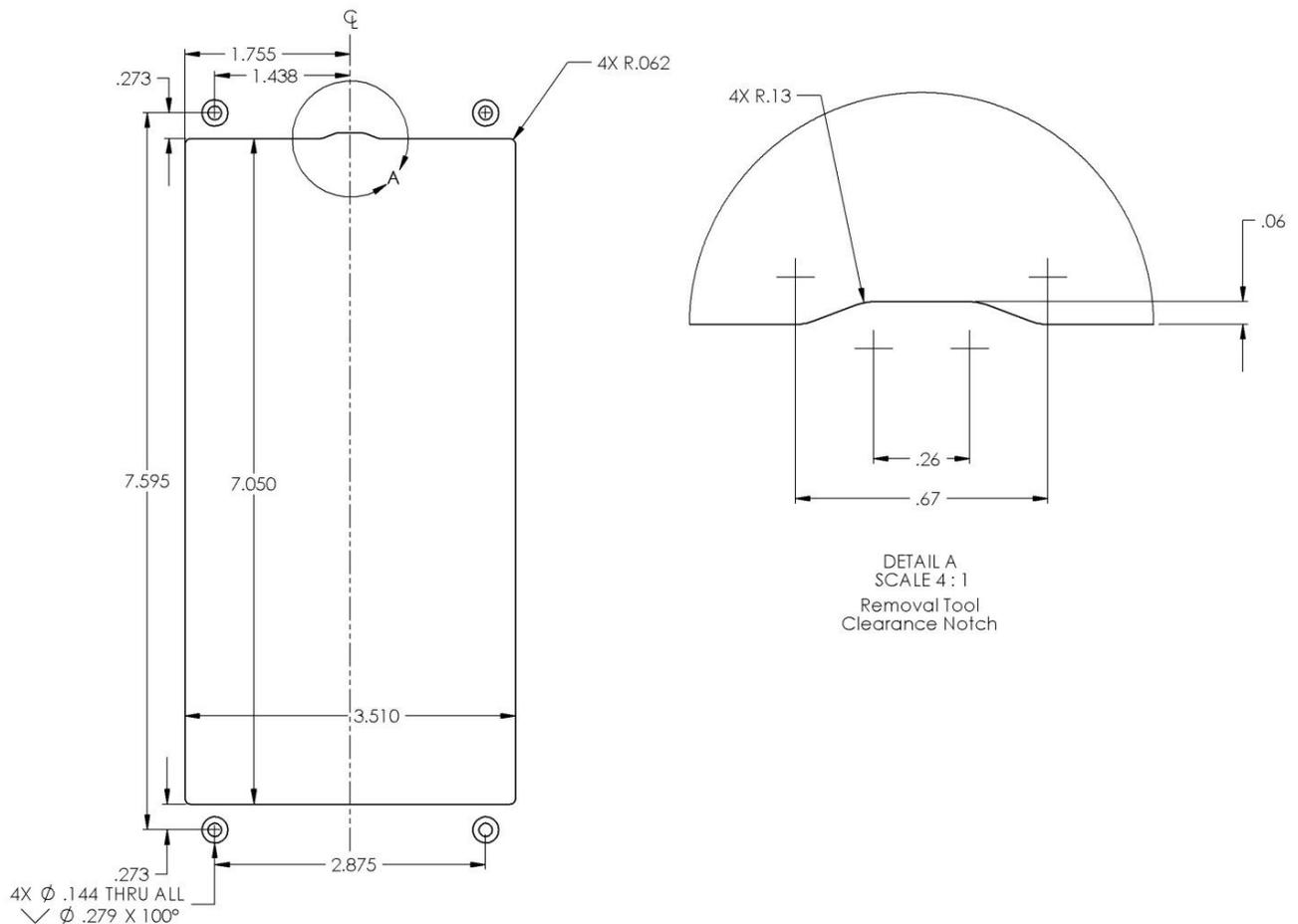

**Figure 6–3: Single Display Recess Mount Cutout (inches)**

**STEP 5 – Cut out the EFD hole and Drill Four Mounting Holes**

- 1) Remove instruments from surrounding area to be cut or remove instrument panel from the aircraft. Verify nothing is in the way of the cutting tool before making the cut.
- 2) Cut the display bezel opening and drill four bracket mounting holes (per EFD) 0.144” in diameter and countersink as required.

- 3) Remove burrs and break sharp edges on the panel (0.005" - 0.015").
- 4) Chemical conversion coat the bare aluminum and primer or paint as required.

**STEP 6 – Install the Recess Mount Brackets and Hardware (Use Figure 6–4 for reference)**

- 1) Fit the spacers (A) between instrument panel and recess brackets (C) as shown in Figure 6–4, using four MS24693–S26 6–32 X 3/8 machine screws or pan head screws may be used if that look is desired. Tighten all four mounting screws and nuts to 12 in–lbs anchoring the brackets to the panel.

**NOTE: Spacers (A) come in a strip of three which can be snapped apart. The thickness of the instrument panel will determine how many spacers will be required. Instrument panels that are 1/8" thick should require one spacer while 1/16" panels may require up to four spacers to provide the desired appearance.**

- 2) Mount EFD Bracket (B) to Recess Brackets (C) using six MS24693–S24 6–32 X 1/4 flat head machine screws.
- 3) Tighten all six mounting screws and nuts to 12 in–lbs.

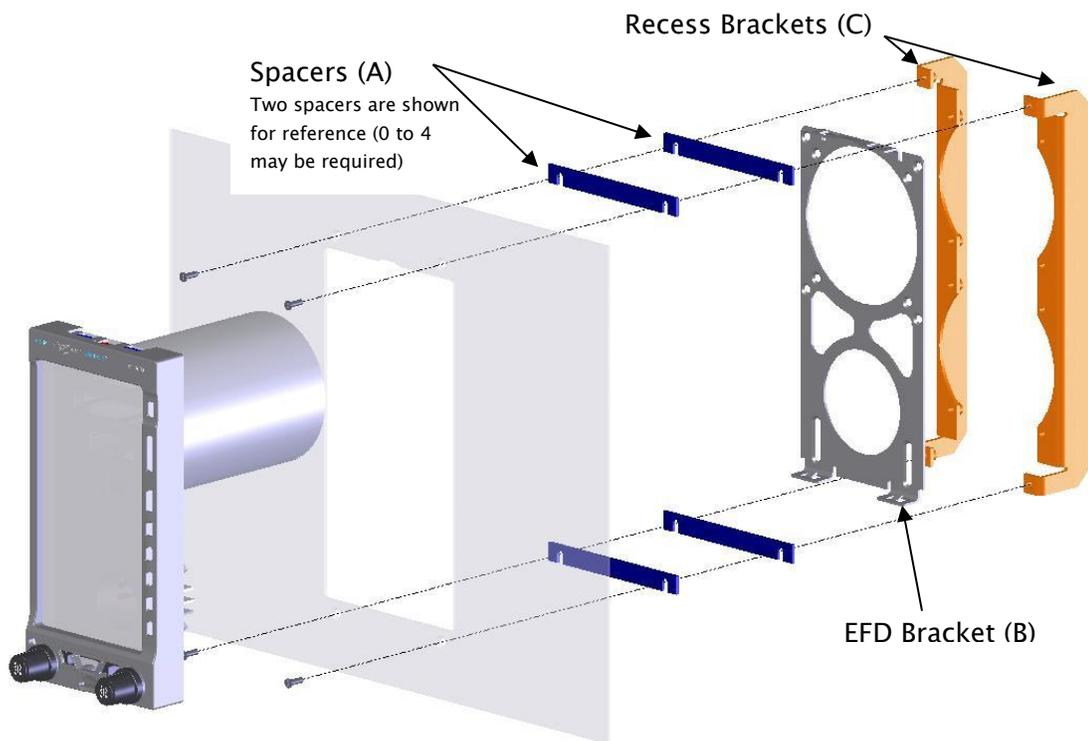

**Figure 6–4: Single Display Recess Mount Bracket Installation**

**STEP 7 – Assemble and Attach the EFD Ground Strap**

- 1) Fabricate one 8" bonding strap from braid with ground lugs at each end.

- 2) Insert a MS24693-S30 6-32 x 3/4" flat head machine screw through either an unused threaded insert or an existing EFD bracket attachment screw (see Figure 6-5). Attach one end of the ground strap to this screw using a MS21044N06.

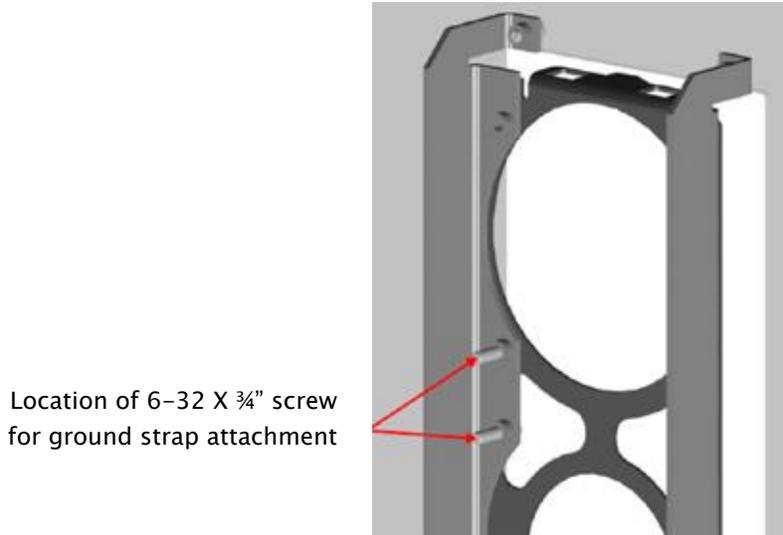

Figure 6-5: Ground Strap Attachment Points

**STEP 8 - Perform the Structural Load Test on the Bracket Installation**

The following test is to structurally substantiate the bracket installation. The applied static test load is determined using 2.9lbs for the EFD mass. See AC 43.13-2B for additional Structural Data.

Direction of Pull (push on bracket)	Load Factor	Static Test Load (load factor x EFD weight)
Forward (toward firewall)	9.0g	9.0 x 2.9 = 26 lbs

Table 6-3: Static Load Table

Use a block of wood or piece of aluminum that will cover the EFD bracket. This ensures an even force is applied to the entire bracket at once. Place mechanical or digital push/pull gauge against block and assert the static test load defined in the table above for a minimum of 3 seconds. Ensure instrument panel and brackets show no signs of permanent deformation.

**NOTE: The recessed brackets are TSO'd and meet the sideward, upward, downward, and forward axis load requirements of the EFD. Therefore only the forward axis is tested above to substantiate the overall bracket installation.**

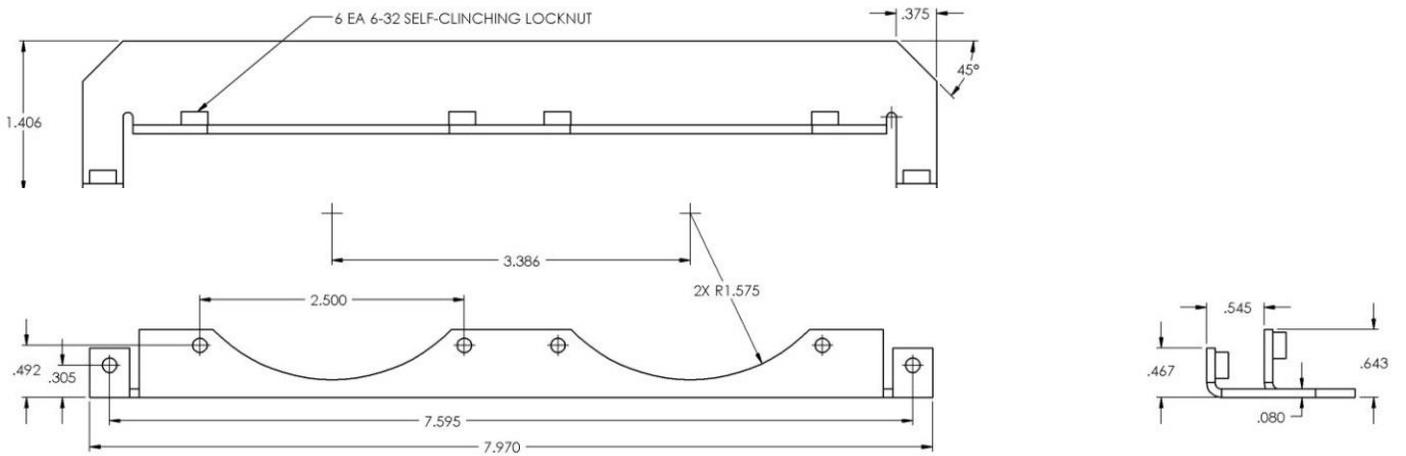

Figure 6-6: Recess Mounting Bracket Dimensions (inches)

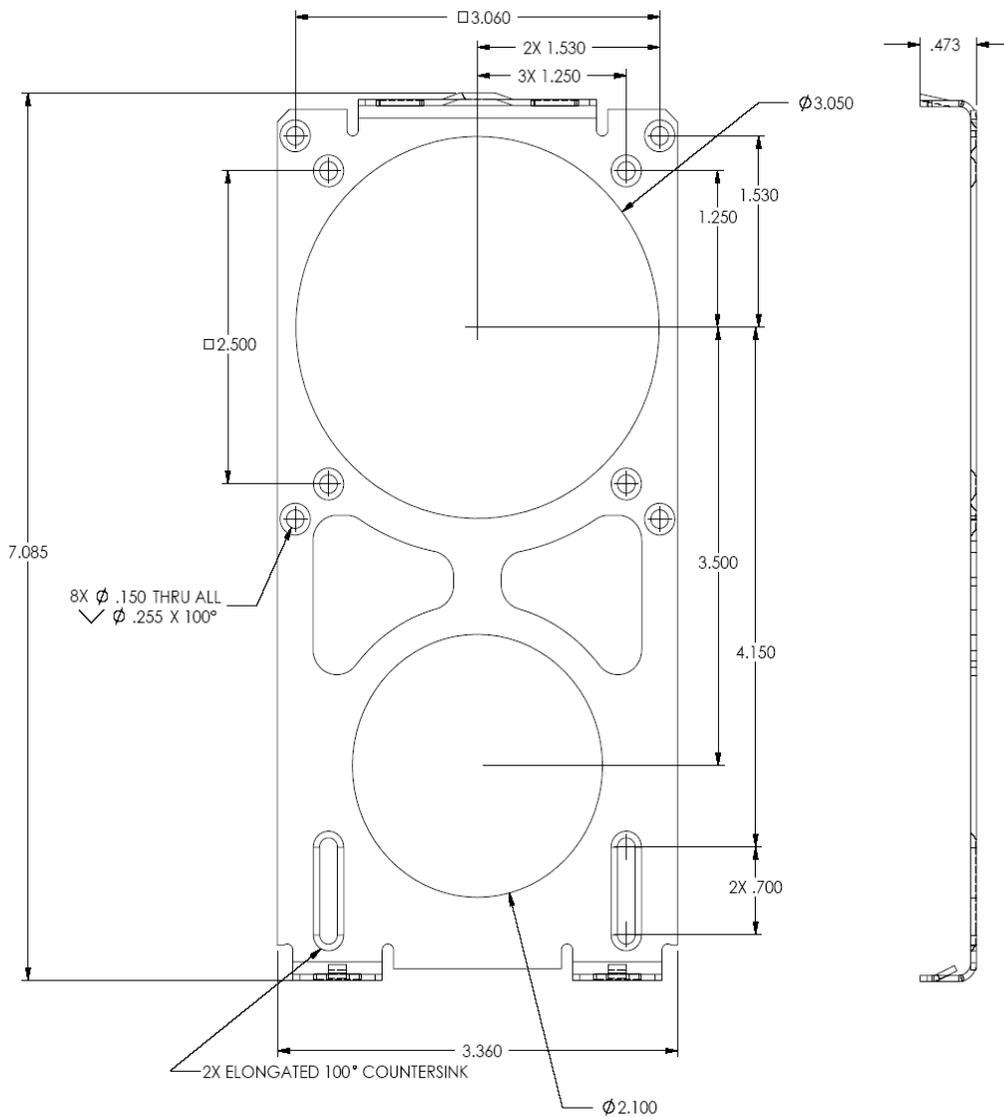
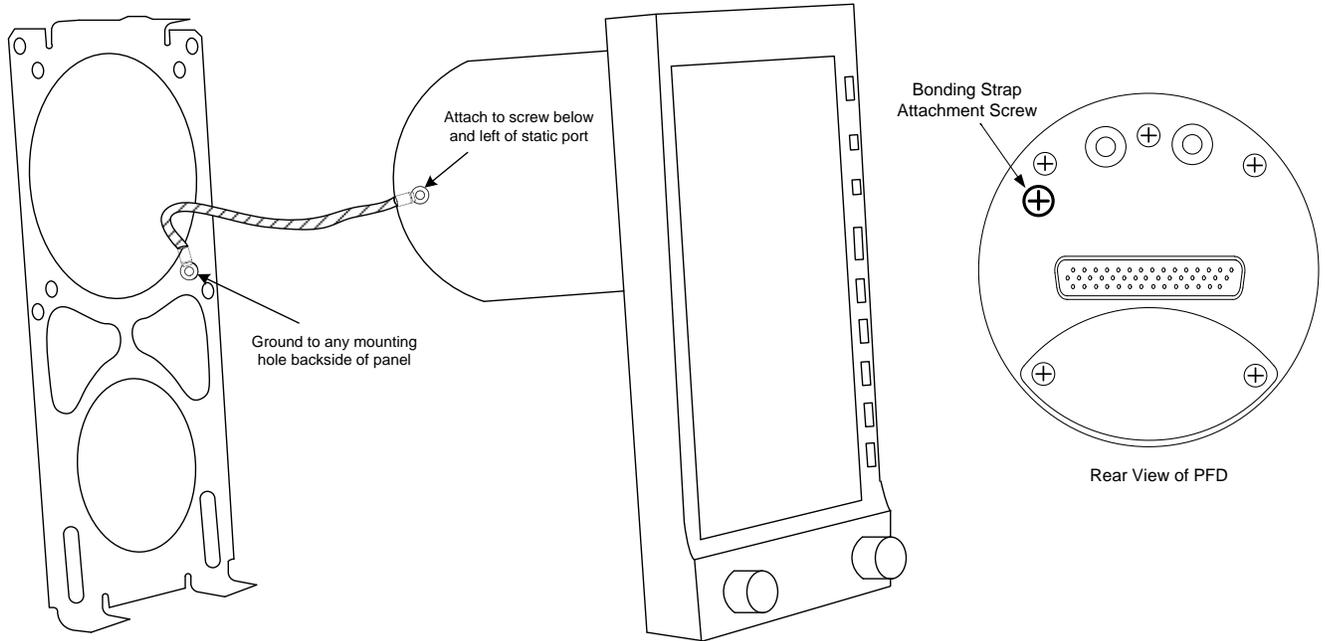

Figure 6-7: EFD Mounting Bracket (inches)

### 6.8.4 EFD Bonding Strap

An 8” or shorter braided bonding strap is required between the screw (below and left of the static port– see Figure 6–8) on the backside of the EFD to a location on the backside of the instrument panel using one of the mounting screws and nuts. Verify  $\leq 3$  milliohms resistance to airframe ground at bonding strap connection point.



**Figure 6–8: EFD Bonding Strap Connection**

### 6.8.5 Pitot and Static Connections

Pitot and Static connections are made to the EFD1000 E5 via two keyed quick connect fittings. These connections will typically require a “T fitting” to be installed in-line with the existing altimeter and airspeed indicators.

The quick connectors are keyed such that they cannot be interchanged. Once the correct quick connector is fastened to the pitot and static lines, they cannot be inadvertently swapped on the rear of the EFD unit.

**NOTE: The pitot quick connector will fit on the EFD static port but the static quick connector cannot be inadvertently connected to the EFD pitot port due to the keying.**

Each connector has a barbed fitting that accepts a 3/16” hose.

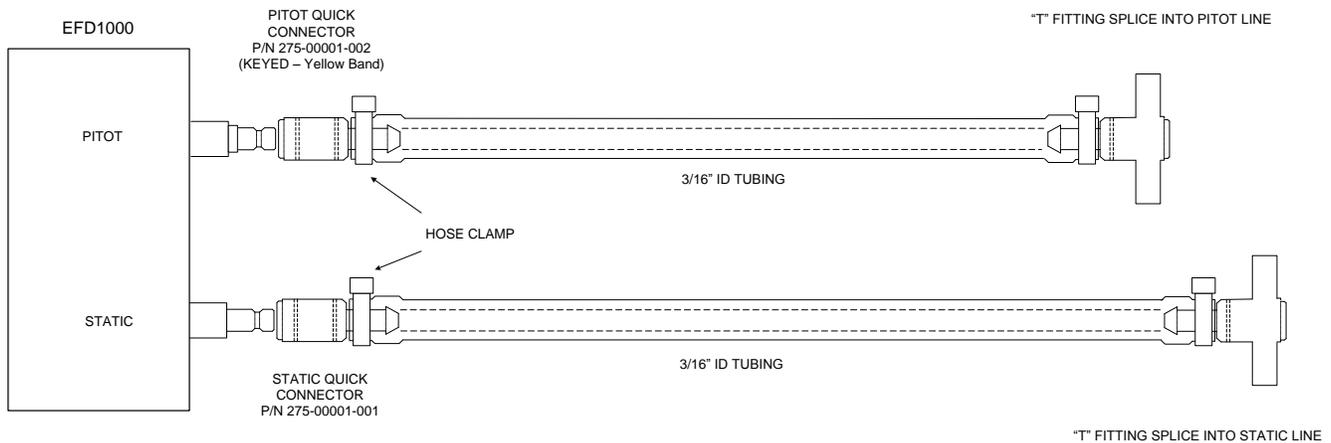

**Figure 6–9: Pitot & Static Quick Connector**

### 6.8.6 Quick Connector Installation

- 1) Insert “T” fitting into existing aircraft Pitot line and secure with the supplied hose clamp (see Figure 6–10).
- 2) Connect a length of pitot line tubing between the “T” fitting and the “P” quick connector. Verify the length of tubing can be installed with no drip loop and that it can be secured away from flight controls. Secure each end with the supplied hose clamps.
- 3) Insert “T” fitting into existing aircraft Static line and secure with the supplied hose clamp (see Figure 6–10).
- 4) Connect a length of static line tubing between the “T” fitting and the “S” quick connector. Verify the length of tubing can be installed with no drip loop and that it can be secured away from flight controls. Secure each end with the supplied hose clamps.
- 5) Secure pitot and static lines as necessary to prevent interference with other aircraft structures and components and to prevent them from kinking when the EFD is slid in to place.

***CAUTION:*** Secure pitot and static lines so that they will not interfere with flight controls and are not at risk of mechanical damage. The lines can soften when the EFD warms and should be secured in a way that prevents the line from kinking.



**Figure 6–10: Pitot & Static Line Connections**

### 6.8.7 Leak Check Requirements

A pitot static leak check is required after the installation of the quick connectors and the EFD1000 E5 is installed. The quick connectors are designed such that they seal when disconnected.

## 6.9 RSM Installation

***CAUTION:*** The RSM is an integral part of the attitude function of the AHRS. A stable and magnetically quiet location for the RSM is essential for proper AHRS operation.

***CAUTION:*** There are special considerations for mounting the RSM on composite, fabric and pressurized aircraft. See sections 6.9.5 and 6.9.6.

The RSM includes magnetic flux sensors which is why it is important to locate the RSM as far away from the cabin and baggage (or “hat rack”) compartment as practical as these areas may have varying magnetic fields (baggage, passengers, etc.).

The RSM should not be mounted within 18 inches of a VHF Comm antenna, 6 inches of a GPS or ELT antenna, or within 12 inches of an active traffic antenna or DME antenna.

The RSM should be mounted to a relatively flat surface such that there is less than .030” gap surrounding the RSM when installed. The RSM must not be mounted to an excessively curved area that could deform the RSM or aircraft skin.

The RSM must not be mounted within a composite fairing such as a fiberglass wingtip cover, or vertical fin cover as these do not protect against direct lightning effects.

### 6.9.1 RSM Internal Mounting

Typically the RSM will be internally mounted within an area of the aircraft fuselage or wing structure that is magnetically benign. For aluminum aircraft, the RSM may be mounted anywhere inside the aluminum structure.

For composite or fabric covered aircraft (see Figure 6–12), the RSM must not be mounted forward of the windscreen, or within 39” of the aft end of the fuselage. It may be mounted within the wing but no closer than 39” of the wingtip. It must not be mounted within the horizontal stabilizer, or within the vertical stabilizer. See Figure 6–12.

***NOTE:*** If internally mounting the RSM a mounting plate must be locally fabricated and approved separately. All mounting instructions for a magnetically quiet location still apply.

### 6.9.2 RSM Inverted or Bottom Mounting

See Figure 6–13. The –003 version of the RSM is designed for inverted bottom mounting. This version may be mounted to any magnetically quiet area inside the fuselage or on the underside of the fuselage. Mounting this RSM to the underside of an aerodynamic surface, such as the wing or the horizontal stabilizer is not approved.

### 6.9.3 RSM External Top Mounting

See Figure 6–11. The RSM may be externally mounted if desired. One reason for doing so is if an upgrade from an EFD1000 E5 to a EFD1000 Pro is being planned for. The Pro has the options of internal GPS and OAT in the –001 RSM which require an external top mount.

For a top external mount the preferred RSM installation area is a minimum of 12 inches behind a typical baggage or (hat rack) compartment to no closer than 39" from the end of the fuselage. The "Less Preferred" areas over the cabin should only be selected if impossible to find an acceptable location within the "Preferred" area of Figure 6-11.

When externally mounted, the NO ZONE areas are hot zones for a lightning strike and are not to be used for mounting the RSM. The RSM must not be mounted externally to the wing, the top of the vertical stabilizer, the horizontal stabilizer, the fuselage forward of the cabin, or within 39" of the tail as measured from the fuselage aft end as shown.

If it is impossible to find a suitable external mounting location in the preferred area, and internal mounting is not possible, it may be permissible to mount the RSM above the cabin. A location will need to be found that is a minimum of 18 inches from any small cabin speakers or electronic device that can cause compass fluctuations. Large cabin speakers may cause RSM interference at distances up to 3 feet. Use the procedure in Section 6.9.4 to locate a quiet area. During operation of the electrical systems, concentrate on those devices that are in the cabin and within the headliner. Be aware that headsets and other items worn by and operated by the flight crew and passengers could potentially interfere with the RSM. Typically this would be when the headset is within 12" of the RSM location. Find a location that cannot be affected by passenger and flight crew headsets while seated or moving about the cabin.

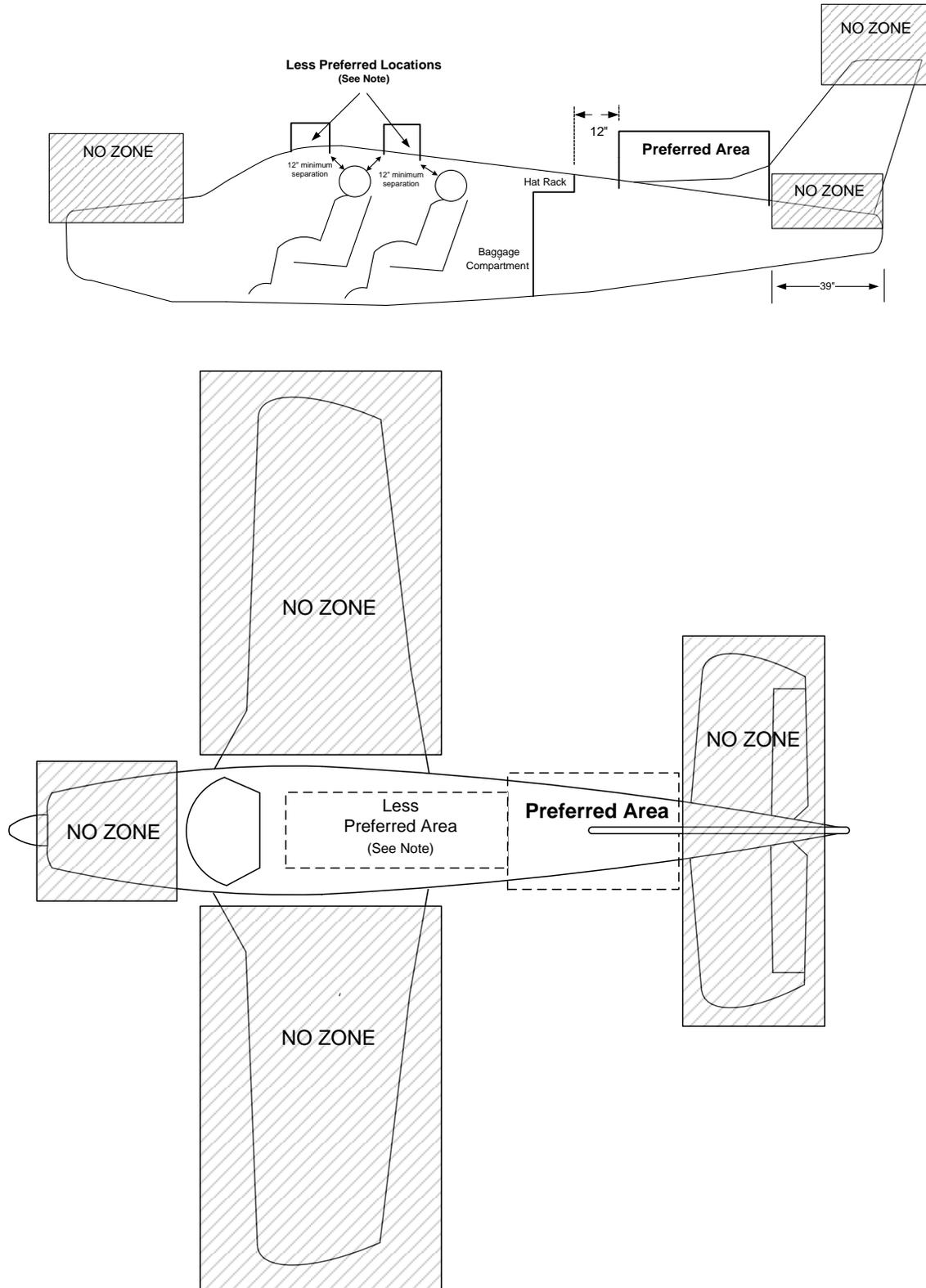

Figure 6-11: RSM-External Mounting Locations (Top/Side View) - all aircraft types

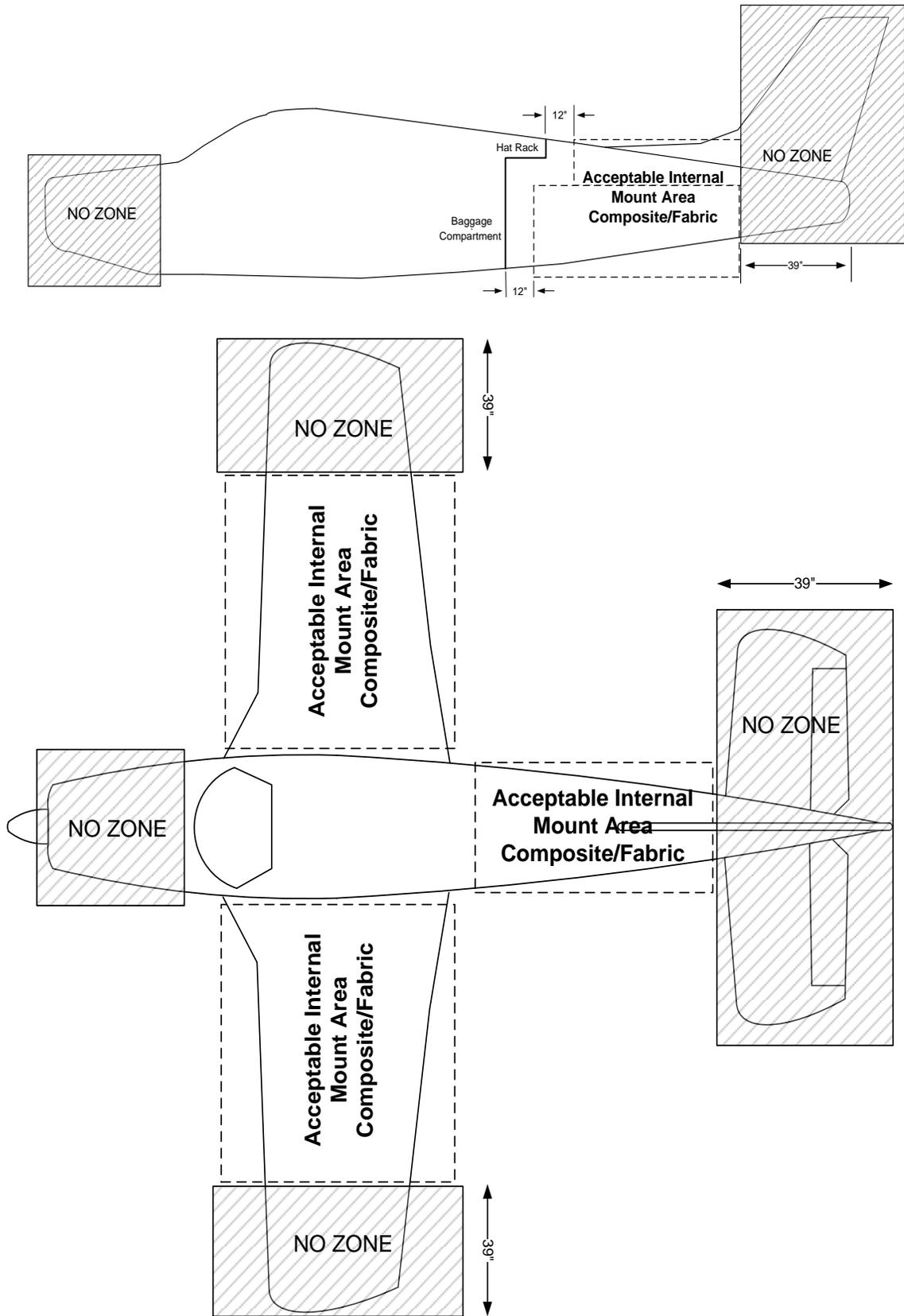

Figure 6-12: RSM Internal Mounting Locations – Composite/Fabric Aircraft

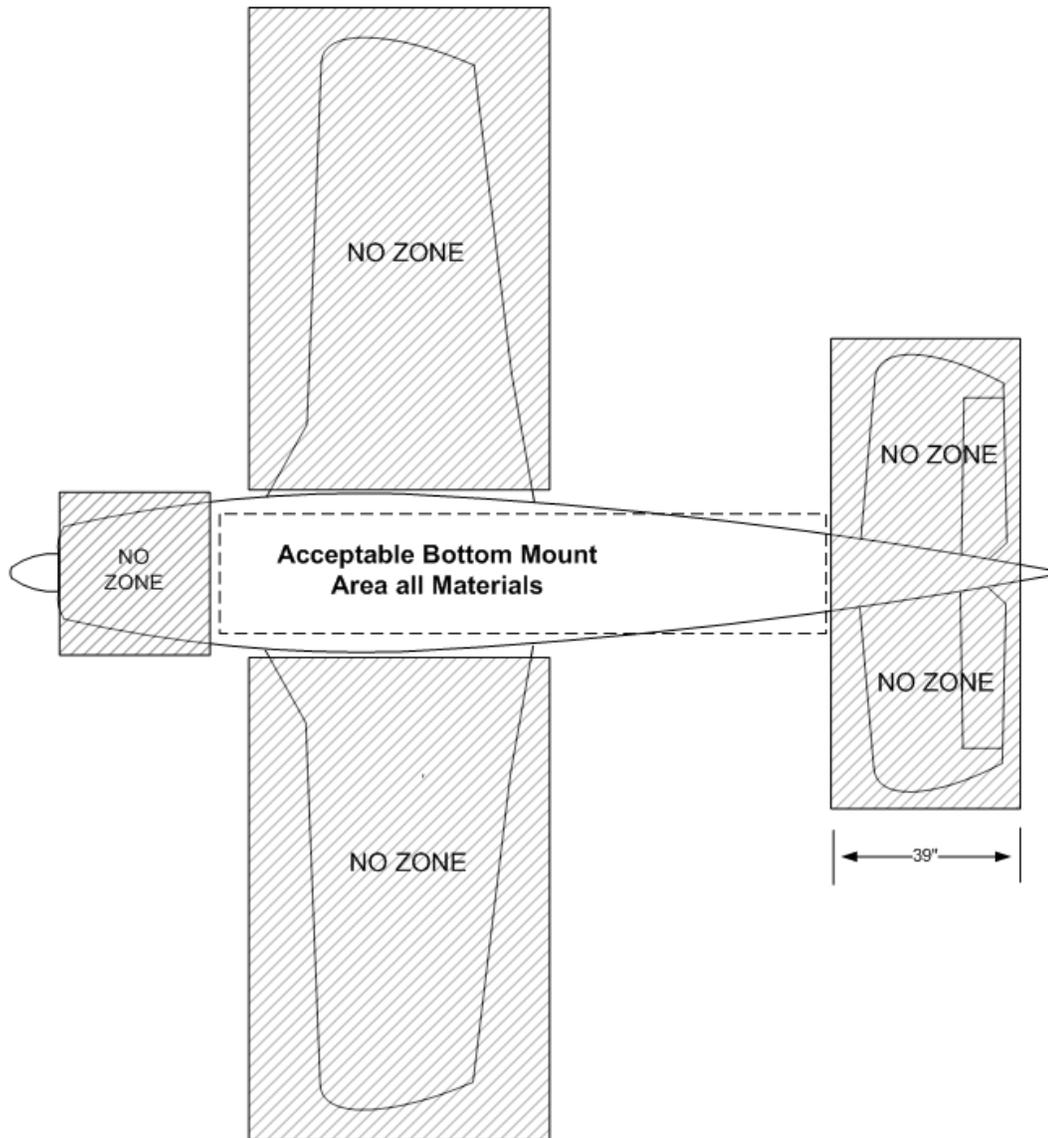

Figure 6-13: RSM-003 External Mounting Locations (Bottom view)

#### 6.9.4 Proposed RSM Location Check

The installer must determine the best RSM location given the above factors. With proper training and careful application, a navigation quality handheld compass (i.e., hiking compass) can be used to find a magnetically quiet area free from the effects of magnetic disturbances from flight controls, autopilot servos, strobes, or any other large magnetic field appliance. The HMR2300 Smart Digital Magnetometer is a more effective tool to properly choose an RSM location, it detects magnetic fields with more precision and should be used with TechNote TN2010-01 to identify RSM locations that are free from magnetic interference.

The RSM can detect magnetic fields in three dimensions. This means that magnetic influences below the RSM can also affect performance. Be sure to evaluate potential magnetic influences above and below the RSM.

**NOTE: Changes to the magnetic field around the RSM can affect the RSM calibration and require revalidation of the RSM performance.**

Known sources of interference include (but are not limited to) the following types of material located near the RSM (normally, these materials within 12 inches can cause interference):

- Steel-wound aircraft air-ducting
- Steel hose clamps
- Steel control cables and turnbuckles
- Steel tube - especially at the welds
- Magnetized or magnetic hardware
- Servos
- Trim motors
- Poor bonding of electrical connections
- Blower motors
- Cockpit or cabin speakers

Known sources of interference due to electrical noise include (but are not limited to) the following. Be sure to check for interference with the following systems operating:

- Servos
- Alternator/Generator and cabling to aircraft battery
- Blower motors
- Stobes, beacons
- Pulse equipment (DME, transponder active TAS, TCAS)
- Air conditioner
- Electrical ground current through the aircraft skin

The following Table shows minimum separation distances from common sources of interference that have resulted in an acceptable magnetic environment. These are guidelines and **will not** result in satisfactory performance in every situation. Magnetic influence is somewhat additive, so multiple sources of interference may require greater separation distances than shown here.

Magnitude Total Gauss Field (TG) <sup>(1)</sup>	Aircraft Equipment or Structure	Suggested Separation to RSM
+/- 20 higher than Magnitude (TG) <sub>(base)</sub>	Ferrous fasteners (non-magnetized)	6 inches
+/- 20 to +/-30 higher than Magnitude (TG) <sub>(base)</sub>	Larger ferrous parts	Unknown - suggest 12 inches
700 - 1000 (too high) or 300 - 400 (too low))	Batteries, Steel Tube, non-magnetized structure/equipment	12 inches

Magnitude Total Gauss Field (TG) <sup>(1)</sup>	Aircraft Equipment or Structure	Suggested Separation to RSM
1200 – 1800 (extremely high) or 200 – 300 (extremely low)	Servo Motors, Fan Motors, magnetized- steel tube/welds/Steel wound ducting/ fasteners	15 inches
Greater than 1800	Speakers	24 inches plus

Note: The separations above are not absolute and further minimum distances may be required! The installing dealer is responsible for choosing a proper RSM location. <sup>(1)</sup> This column is only applicable to the HMR2300 tester.

Place the HMR or small handheld compass in the proposed RSM mounting location and move the compass around the location looking for needle deflection. There should be no more than 2° of compass needle movement within an area 18" x 18" x 18" around the proposed location. Should the compass show excessive needle movement it would be required to find a new location or, if feasible, treat the affected area with a degaussing coil. Contact your authorized dealer for information on obtaining or using a handheld degaussing coil. A degaussing coil can be purchased at most audio and video stores.

Operate flight controls from stop to stop and verify no more than 2° of compass needle movement. Should the compass show excessive needle movement it would be required to find a new location or degauss the flight control cables and or flight control hardware.

Operate all electrical systems. The compass needle should not deflect more than 2 degrees during testing.

If a location cannot be found with less than 2 degrees of deflection then the electrical device causing the interference will need to be determined. The device causing the interference may need to be re-bonded or the wiring may need to be relocated.

If the HMR or compass does not show any deflection from electrical or mechanical sources, then that location should be acceptable to mount the RSM. The installer is responsible to choose an RSM location that provides satisfactory heading accuracy.

**6.9.5 Pressurized Aircraft**

On pressurized aircraft it may be necessary for the RSM wiring to penetrate the aircraft pressure vessel. The installer is responsible for obtaining proper documentation and FAA approvals from either the airframe manufacturer or from a DER or FAA field office for any penetrations of the pressure vessel or bulkhead.

***NOTE: Penetration of the pressure vessel is not approved under this STC and will require separate approval.***

***NOTE: Mounting the RSM on the pressure vessel is beyond the scope of this STC and requires separate approval.***

**6.9.6 RSM Mounting on Non-Metal or Damage-Tolerant Design Aircraft**

Approval for the structural aspects of mounting the RSM to a composite or fabric skinned aircraft, including consideration for the direct effects of lightning, is beyond the scope of the EFD1000 E5 AML STC. Separate FAA approval for structural and lightning direct effects considerations is required before mounting the RSM on these aircraft types.

The installation information for the RSM in this manual is satisfactory to meet the requirements for the direct effects of lightning for all metal aircraft.

It is not possible to determine the lightning direct effects on equipment mounted internally in composite and fabric aircraft. Therefore, the only acceptable areas for RSM internal mounting are shown in Figure 6-12. The same bonding requirements for an external mounting must be adhered to.

Though separate approval must be obtained for the RSM structural and, in the case of fabric and composite aircraft, lightning direct effects; installation of the remaining EFD1000 E5 system components is approved under the EFD1000 E5 AML-STC. This includes HIRF and lightning induced transient susceptibility approval of the EFD1000 E5 system installation (i.e. display, RSM, CM, ACU, and associated wiring).

**6.9.7 RSM Mounting Angles**

For RSM mounting the following maximum mounting angles apply.

**NOTE: For aircraft operating in the latitudes above 55N or in the southern fourth of Australia it is recommended that the RSM mounting angles be at 5 degrees or less.**

**6.9.7.1 Longitudinal Axis**

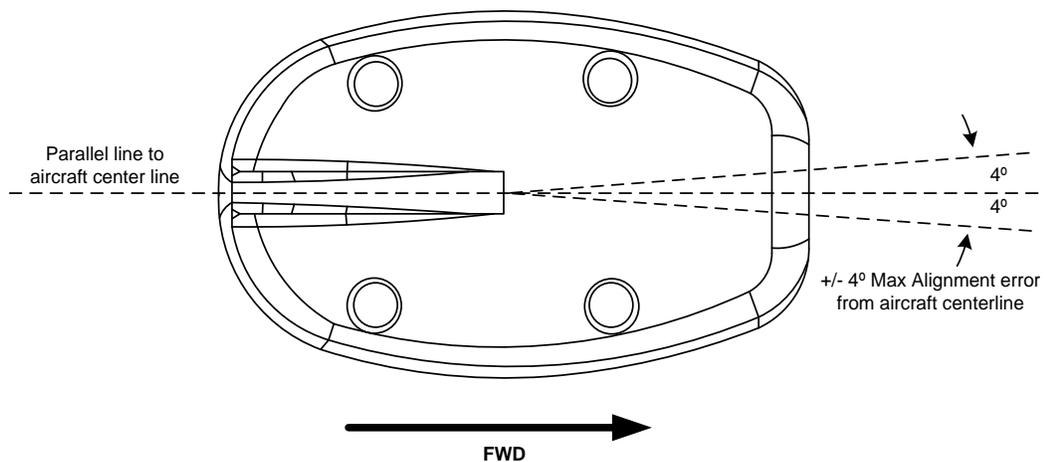

**Figure 6-14: RSM Top View longitudinal Alignment**

**6.9.7.2 Pitch Axis**

Maximum fore and aft tilt is in relation to the aircraft waterline. An aluminum shim might be required to keep orientation within limits (see Section 6.9.11 for shim fabrication).

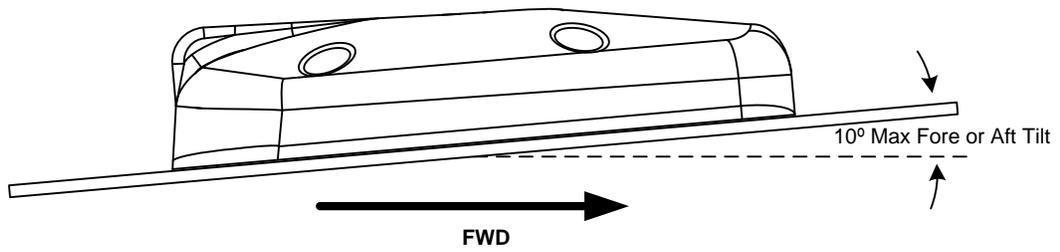

Figure 6-15: RSM Fore or Aft Max Tilt

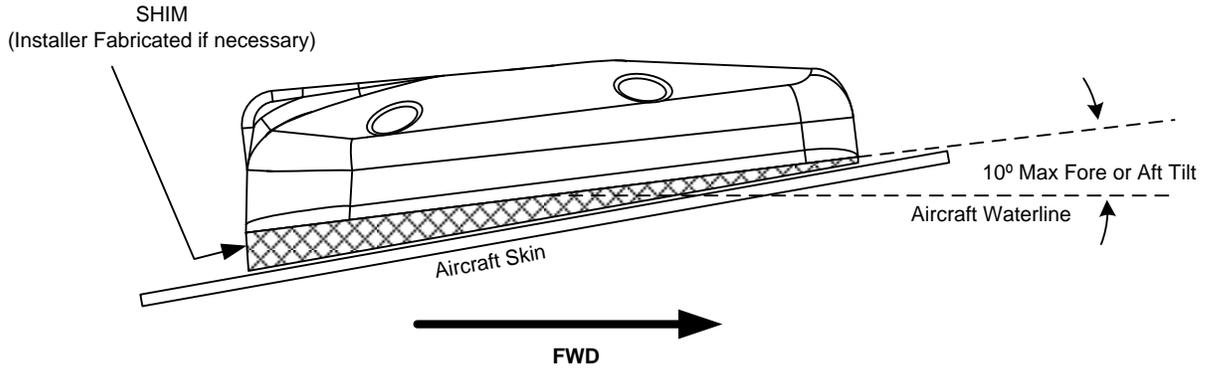

Figure 6-16: RSM Fore or Aft Max Tilt (Shim installed)

6.9.7.3 Roll Axis

Maximum side-to-side tilt is 10 degrees in relation to wings level. An aluminum shim might be required to keep orientation within limits (see Section 6.9.11 for shim fabrication).

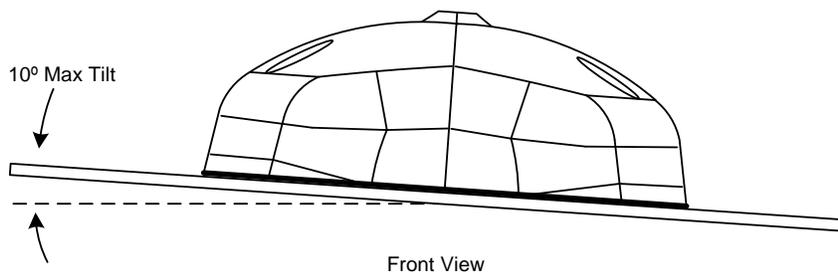

Figure 6-17: RSM Side to Side Max Tilt

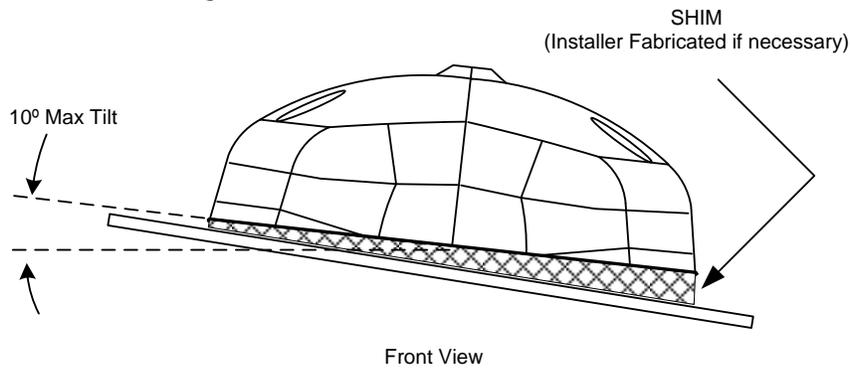

Figure 6-18: RSM Side to Side Max Tilt (Shim installed)

### 6.9.8 RSM External Mount – Aluminum Skin

This STC approves the use of the doubler shown in Figure 6–19 for Aluminum Skinned aircraft only. Mounting the RSM externally to a composite or fabric aircraft is not approved by this STC and will require that the installer obtain separate approval of the RSM mounting on these classes of aircraft. After the RSM mounting has been approved, this STC may be subsequently installed.

The doubler may be purchased from Aspen under P/N 503–00015–001 or may be installer fabricated using the dimensions and rivet holes as shown. Should the installer wish to deviate from this doubler in size, rivet count, rivet spacing, or doubler thickness, they are required to seek separate approval.

#### 6.9.8.1 RSM Doubler Fabrication

- 1) Determine the thickness of the aircraft skin.
- 2) For aircraft skins 0.050” thick and less the doubler should be made from 0.050” material or optionally Aspen P/N 503–00015–001 doubler may be used. For aircraft skins thicker than 0.050 the doubler should be made from material the same thickness as the aircraft skin.
- 3) Fabricate the doubler from 2024–T3 AMS–QQ–A–250/5 to the dimensions in Figure 6–19, Tolerances  $\pm 0.030$ .

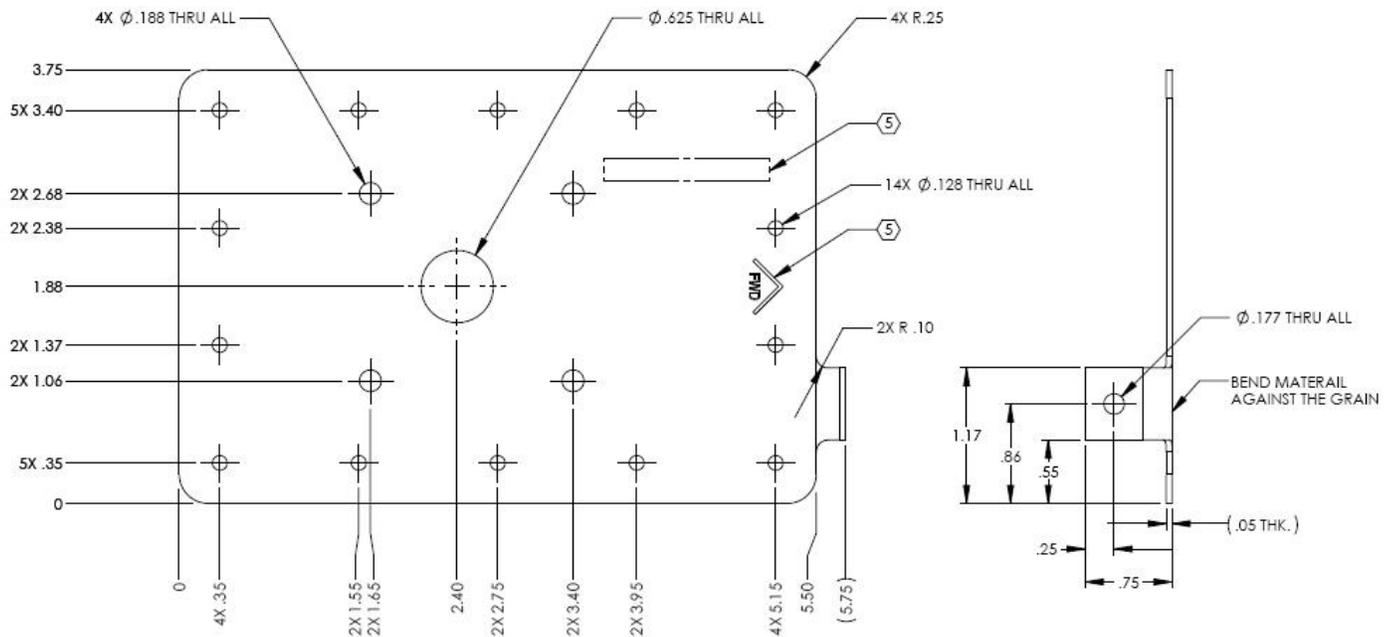
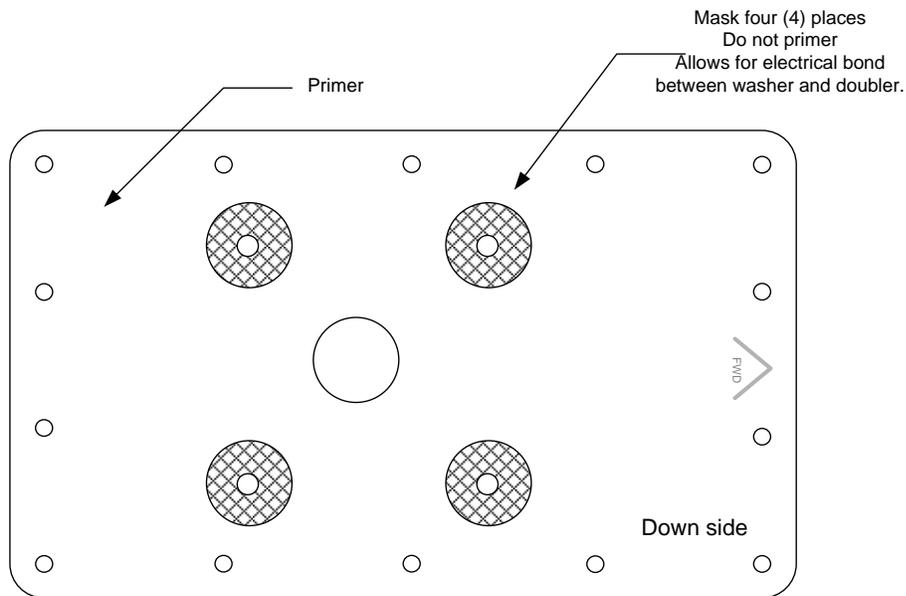

Figure 6–19: RSM Doubler P/N 503–00015–001

**NOTE:** The tab for the RSM shield ground lug connection may be bent as shown or the entire forward edge may be extended and bent down as a tab.

- 4) Remove burrs and break sharp edges (0.005” – 0.015”).
- 5) Finish with Alumiprep Etch and Alodine Conversion Coating.

- 6) Mask around the four (4) mounting holes the diameter of the mounting washers or 1/2" on the down side of the doubler (see Figure 6-22). Prime that side with epoxy primer per MIL-P-23377. Do not prime the side that faces the aircraft skin. This allows for a doubler to aircraft skin bond and mounting washer to doubler bond.
- 7) Mark forward direction on doubler because pattern is not symmetrical.
- 8) Using the doubler as a template match drill holes in aircraft fuselage at location determined from Section 6.9.4. Doubler must be aligned to the longitudinal axis of the aircraft to within  $\pm 4^\circ$  (see Figure 6-14).



**Figure 6-20: Masking of Doubler**

- 9) Remove burrs and break sharp edges on the aircraft skin (0.005" - 0.015")
- 10) Burnish the aircraft skin on the inner surface in the area where the doubler will mount. Apply Alodine 1201 and do not prime.
- 11) The doubler is attached to the inside surface of the aircraft skin with solid rivets.
- 12) For aircraft skin less than 0.032 thick install with MS20470AD4 protruding head rivets.
- 13) For aircraft skin thickness of 0.032 install with NAS1097AD4 rivets flush in the fuselage skin. Carefully control the countersink depth to not knife-edge the fuselage skin.
- 14) For aircraft skin thicknesses 0.040 to 0.050 install with NAS1097AD4 rivets flush in the fuselage skin.
- 15) For aircraft skins 0.063 or thicker install with NAS1097AD5 rivets flush in the fuselage skin.

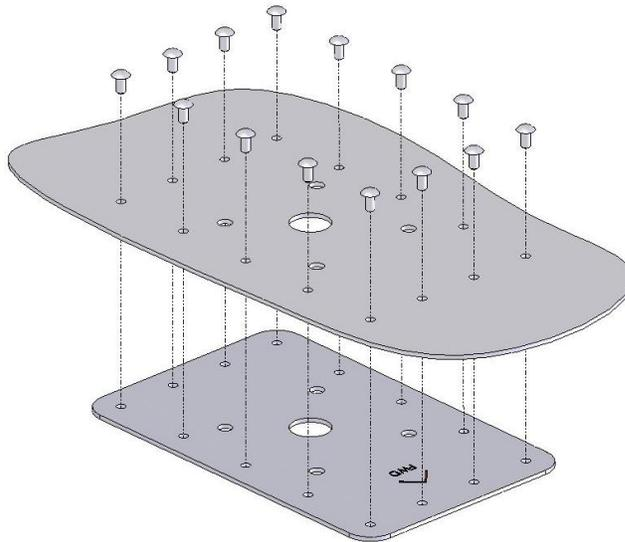

**Figure 6-21: Doubler Installation**

**6.9.9 RSM Internal Mount**

The installer must use a suitable existing shelf or fabricate a suitable mounting bracket for internally mounting the RSM. Use AC43.13-2B Chapter 1 for additional structural data.

**6.9.10 RSM Installation**

**CAUTION:** Do not use a magnetic tipped or electric screwdriver to mount the RSM as this may magnetize the RSM and cause heading errors.

**CAUTION:** Only non-ferrous mounting hardware can be used (i.e., screws, nuts, washers, nutplates) to mount the RSM. Use of any ferrous hardware may cause compass errors. The supplied Brass hardware should be used.

**NOTE:** The RSM contains a sensitive magnetometer. Nearby ferrous components or hardware can magnetize the RSM and/or cause erroneous indications.

- 1) It is not required to remove aircraft surface paint below RSM unless an aluminum shim was required on extreme mounting angles. The shim must be bonded to the fuselage. Bonding of RSM is through four (4) mounting screws to doubler.
- 2) Install ring terminal to RSM shield ground wire.
- 3) Install RSM on aircraft and secure using four (4) screws, four (4) washers, and four (4) nuts as identified below. Installer may substitute non-ferrous nut plates for washers and nuts provided the nutplates are attached to the doubler only and not the aircraft skin.

Description
8-32 Brass screw 1¼" MS35214-47
Brass locking nuts MS21044B08 (formerly AN365-B832)
Brass Washer NAS1149B0832H (formerly AN960-B8)

**Table 6-4: RSM Mounting Hardware**

- 4) Torque hardware to 12–15 in-lbs. Do not over-torque the hardware as it may cause the RSM housing to crack.
- 5) Attach ring terminal to ground stud on RSM doubler tab.
- 6) Apply a bead of non-corrosive sealant around the RSM.

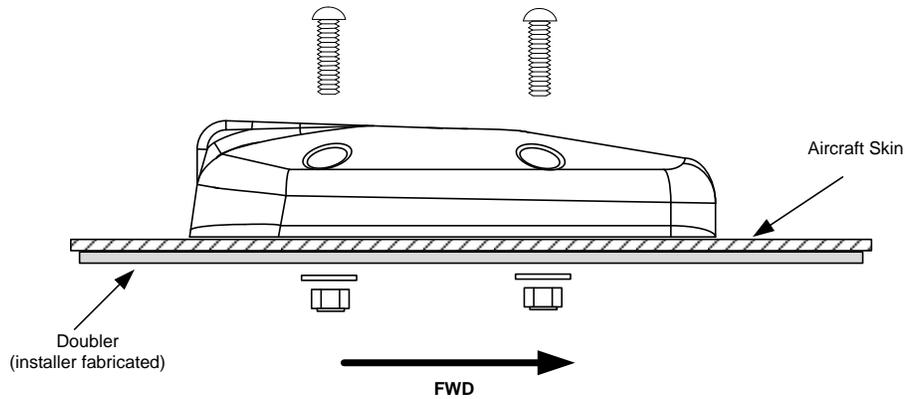

Figure 6–22: RSM Mounting

6.9.11 RSM Shim Fabrication (if necessary)

If the RSM exceeds the mounting limits of Section 6.9.7 a shim will be required.

Fabricate a shim with the dimensions of the RSM baseplate. Optionally the shim can be made square and slightly larger than the RSM baseplate for ease of construction (see Figure 6–23).

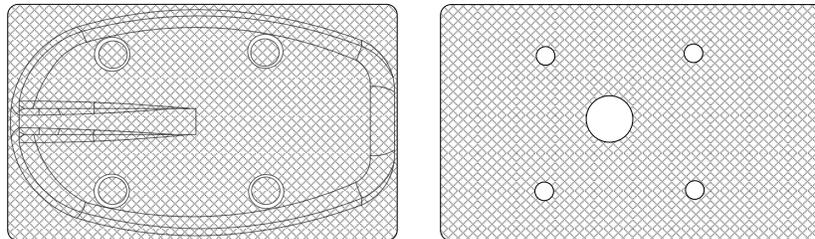

Figure 6–23: Example Shim Top View

The shim must not exceed the minimum and maximum thickness as shown in Figure 6–24. Use of a thicker shim is acceptable but not approved under this STC. A thicker shim will require a local approval.

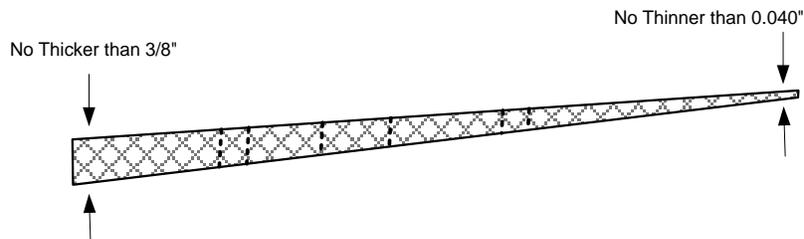
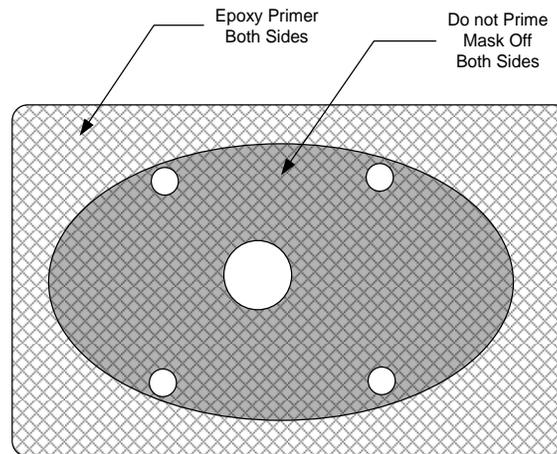

Figure 6–24: Example Shim Side View

- 1) Use RSM doubler as a template to mark shim stock.
- 2) Fabricate shim from 2024-T3 aluminum with the four (4) mounting holes and 0.625" cable pass-thru drilled through.
- 3) Remove burrs and break sharp edges (0.005" - 0.015")
- 4) Finish with Alumiprep Etch and Alodine Conversion Coating.
- 5) Mask off top side of shim 1/4" inside mounting surface of RSM and mask off a similar area on the bottom so that these areas remain Alodine only (see Figure 6-25). Prime unmasked areas with epoxy primer per MIL-P-23377. Paint to match aircraft color if desired.



**Figure 6-25: Masking of Shim for Priming**

- 6) The shim must be bonded to the aircraft skin by removing the paint and prepping the aircraft surface where the shim and RSM will be mounted. Remove paint 1/2" inside the outer footprint of the RSM mounting location. Burnish the aircraft skin and apply Alodine 1201, do not prime.
- 7) Sandwich the shim between the aircraft skin and the RSM following the RSM installation procedure in Section 6.9.10.
- 8) Apply non-corrosive sealant around shim and RSM.

## 6.10 ACU/ACU2 Installation

The ACU/ACU2 has no user interface, and therefore can be remote mounted. The optimum mounting location is an area that minimizes wire runs to interfacing equipment. This typically means near the autopilot computer if installed.

When mounting the ACU/ACU2 find a location in the aircraft of known load carrying capabilities such as:

- Existing Avionics Shelf
- Baggage compartment
- Radio Rack
- Cockpit Floor

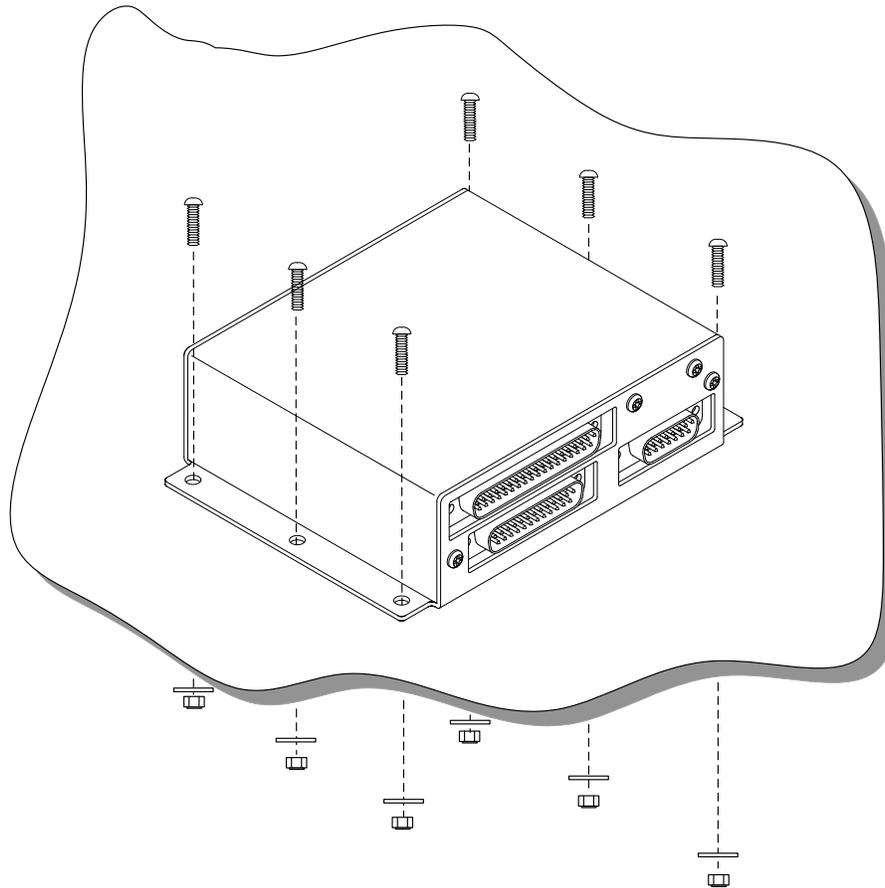

*Figure 6-26: ACU/ACU2 Mount to Flat Metal Shelf*

### 6.10.1 ACU/ACU2 Mounting

Mount the ACU to existing shelf in any orientation using six (6) MS35206 #8-32 screws, six (6) NAS1149FN832P washers, and six (6) MS21044N08 #8-32 self-locking nuts. Tighten nuts to 12 in-lbs.

Installation of the ACU/ACU2 must be in accordance with AC43.13-2B, Chapter 1 Paragraphs 100 to 114, pages 1 to 8. An unpainted surface of the ACU case must be bonded to aircraft ground either through mounting to a metal shelf or with an installer fabricated bonding strap of wire braid or single stranded wire no more than 12 inches in length. Attach ground lug of bonding strap to one of the mounting screws if required. Refer to AC 43.13-1B paragraphs 11-187 to 11-190, pages 11-73 to 11-79 for additional bonding information.

Verify ACU case to airframe ground has  $\leq 3$  milliohms of resistance.

Should a shelf or bracket need to be fabricated in order to install the ACU it is beyond the scope of this STC and will require separate FAA approval for that modification.

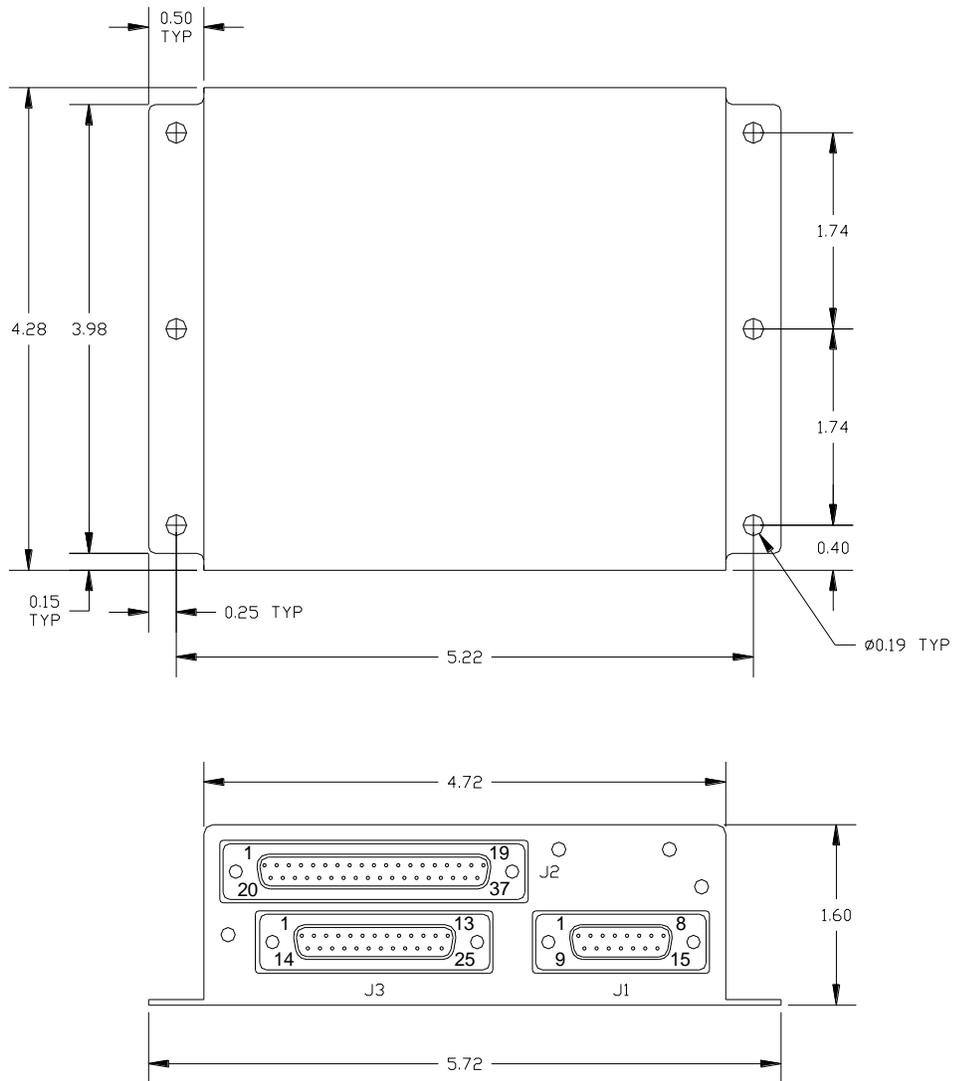

Figure 6-27: ACU Dimensions (inches)

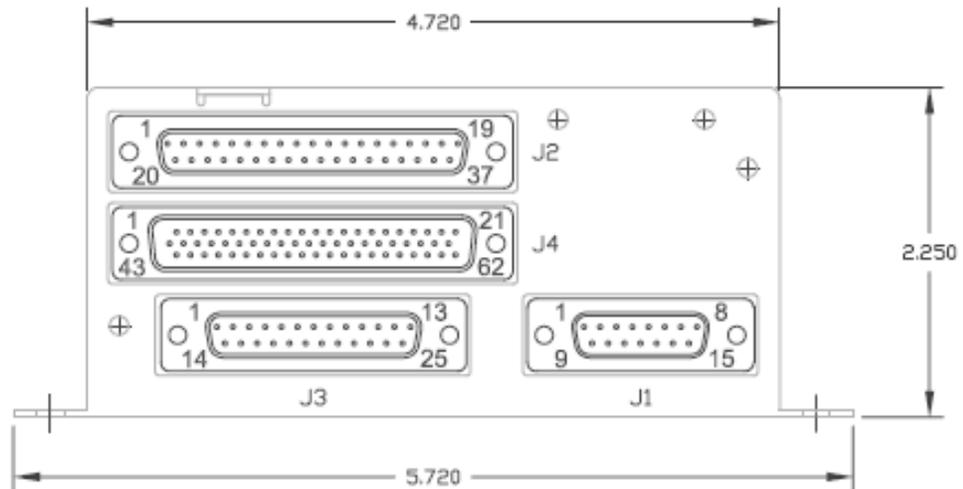
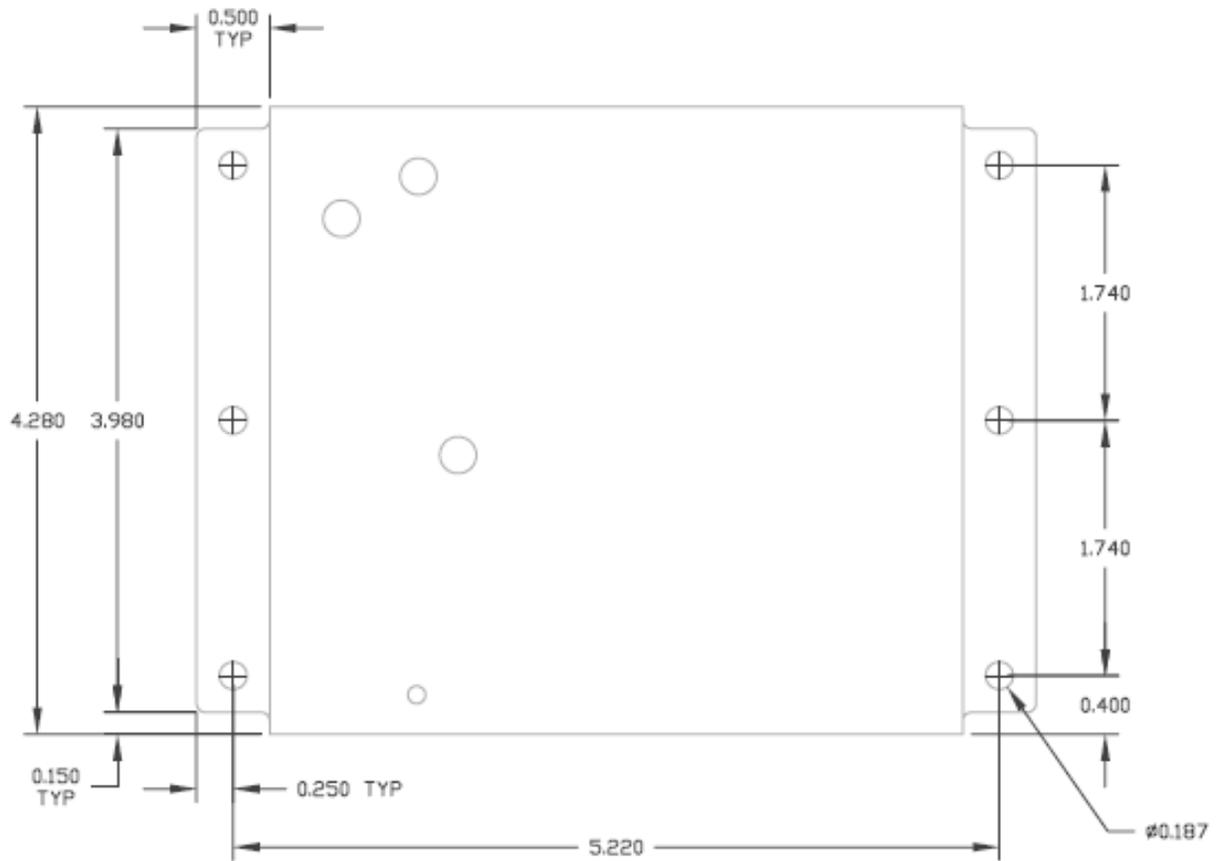
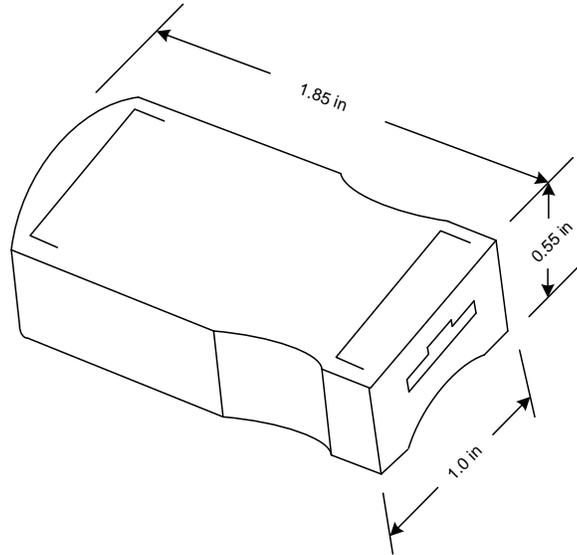

Figure 6-28: ACU2 Dimensions (inches)

### 6.11 Configuration Module Installation

The Configuration Module will be cable tied to the EFD wire harness. Leave just enough slack in the cable ties so that the configuration module can slide along the EFD cable. This will prevent strain on the configuration module connector while the EFD harness is manipulated during installation and subsequent removal/replacement.



*Figure 6-29: Configuration Module Dimensions (inches)*

Cable Tie two (2) places

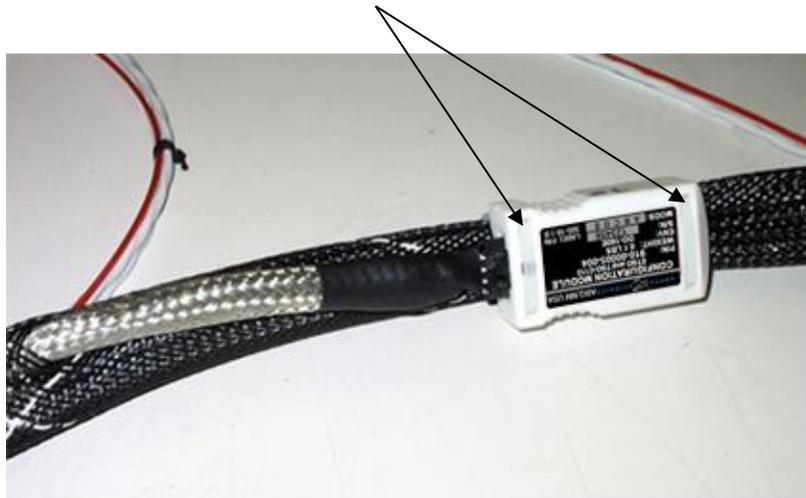

*Figure 6-30: Configuration Module Tie Wrapped to Harness*

THIS PAGE IS INTENTIONALLY LEFT BLANK

## 7 Electrical Installation

### 7.1 Electrical Load Analysis

Perform an electrical load analysis to verify the aircraft complies with FAR 23.1351(a) using the current draw of each installed component as determined from Table 7-1 below.

Component	Current Draw (amps)
EFD1000 E5 (EFD)	2.4 nominal @ 28Vdc 4.8 nominal @ 14Vdc
RSM – Remote Sensor Module	Current Draw included in EFD1000 E5
ACU – Analog Converter Unit	0.5 nominal @28Vdc 1.0 nominal @ 14Vdc
ACU2 – Analog Converter Unit 2	0.5 nominal @ 28Vdc 1.0 nominal @ 14Vdc
Configuration Module	Current draw included in EFD1000 E5

*Table 7-1: Current Draw*

### 7.2 Electrical Installation

#### 7.2.1 EFD1000 E5

A dedicated 7.5 amp pull type circuit breaker and switch or breaker/switch combination for the EFD1000 E5 must be installed in a location accessible to the pilot while seated. The breaker will be powered from the switched battery or essential bus. Label the switch and/or breaker “ASPEN EFD” The switch must be rated for at least 7.5 amps continuous duty. Record the location of circuit breaker and switch in the Instructions for Continued Airworthiness.

#### 7.2.2 ACU or ACU2 (optional)

A two (2)-amp pull type circuit breaker for the ACU/ACU2 must be installed in a location accessible to the pilot while seated. Wire the power source from the avionics bus (switched battery bus if no avionics bus exists). The breaker is to be labeled “ACU”. Record the location of circuit breaker in the Instructions for Continued Airworthiness.

#### 7.2.3 Miscellaneous Wiring

Use of MIL-C-27500 shielded wire and MIL-W-22759 single conductor wire is recommended. All wires should be fabricated as shown in Section 9 keeping all grounds as short as possible.

Wires and connectors must be clearly marked per FAR 23.1365(d).

Wires and wiring bundles must be secured in such a way to eliminate risk of mechanical damage and minimize exposure to heat and fluids per FAR 23.1365(e).

### 7.2.4 HIRF/Lightning Requirements

In order to meet HIRF and Lightning requirements it is required that the following cable runs use either an over braid applied during fabrication or double shielded wires. The over braid or double shield must extend within the back shell and must be grounded at both ends.

- All ARINC 429 and RS-232 wiring into or out of the EFD require either a double-shielded wire, or a tinned copper over braid be applied over the twisted shielded pair. See NOTE 1 on Wiring Diagrams 9-4 through 9-14.

The following wires require single shields to comply with HIRF and Lightning requirements:

- Aircraft power to the EFD requires a single stranded shielded wire from circuit breaker to EFD. See Figure 9-1.
- EFD to Configuration Module comes as an assembly with color coded wires and uses an over braid over non-shielded single conductor wires.

EFD1000 E5 to RSM wiring does not require the over braid or double shield, only what is specified in Section 7.2.6.

ACU to GPS, ACU to VLOC receiver, and ACU to autopilot require no additional shielding just what is specified in the wiring diagrams of Section 9.

### 7.2.5 EFD to GPS/VLOC/ACU Wiring

Use tinned copper over braid or double-shielded wires on all ARINC 429 and RS-232 wires entering or exiting the EFD back shell. Ground the over braid and wire shields within the back shell. If using double shielded wire it may be difficult to terminate all shields within the back shell. If this is the case then use a piece of tinned copper over braid that extends at least 6 inches outside the back shell to cover all unshielded wires (see Figure 7-1).

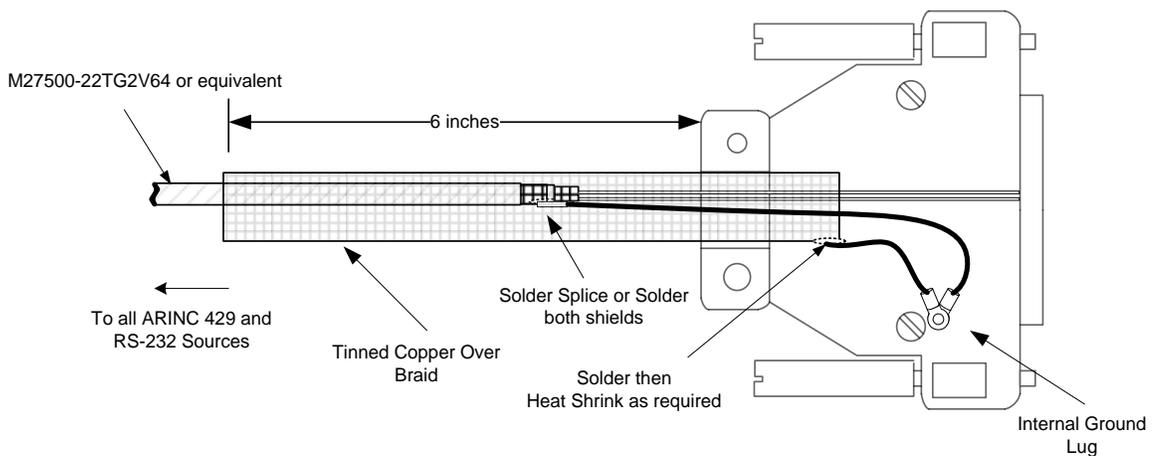

**Figure 7-1: EFD Back Shell Grounds**

At the GPS/VLOC/ACU terminate the over braid within the back shell or as close as possible. Ground the over braid at this end using a pigtail as short as possible. If using

double shielded wires then ground both shields at the GPS/VLOC/ACU with pigtail as short as possible.

**7.2.6 RSM Wiring**

The EFD1000 E5 to RSM wiring run is made with a single cable seven (7) conductor shielded wire. M27500–A24SD7T23 or M27500–22TG7T14 seven (7) conductor shielded cable can be used. Cable runs longer than 35ft are not recommended.

Ensure that a trap or drip loop is provided to prevent fluids or condensed moisture from running into wires and cables dressed downward to a connector, terminal block, panel, or junction box. See AC 43.13–1B Chapter 11.

**7.2.6.1 Assembly using Aspen prefabricated 35ft and optional 50ft cables**

This cable assembly is prefabricated with the following wire color markings and will be cut to length at the EFD1000 E5.

RSM Pin#	EFD Pin#	35ft Cable (412–00005–001)	50ft Cable (412–00006–001)
1	30	White/Black	Green/White
2	31	White/Red	Green
3	32	White/Orange	Brown
4	33	White/Yellow	Orange/White
5	34	White/Green	Orange
6	35	White/Blue	Blue, Blue/White
7	36	White	Brown/White

**7.2.6.2 Assembly using M27500–A24SD7T23 Cable**

Terminate the aircraft side of the RSM wiring with the Hirose circular connector from installation kit as shown in Figure 7–2 below. Due to the compact design of the Hirose connector it may be easier to solder the wires to the solder cups on the bench versus inside the tail of the aircraft. Use a fine tip soldering iron for this procedure.

- 1) Pass the cable through the hood and metal cover. Strip back the insulation to expose the shielding and wires with the dimensions that are shown.
- 2) Stake the metal clamber to the shield in the location shown. A hexagonal crimper such as the ones used for BNC Coax connector assembly work can be used to crimp it to approximately 5.2mm outside diameter.
- 3) Assemble the two pieces of the connector such that the ring retains the solder cup piece. Discard the washer as it is not required.
- 4) Solder the seven (7) 24 AWG wires to the connector.
- 5) Thread metal cover onto connector.
- 6) Insert screw into metal cover so that it indents into metal clamber.
- 7) Put hood over metal cover.

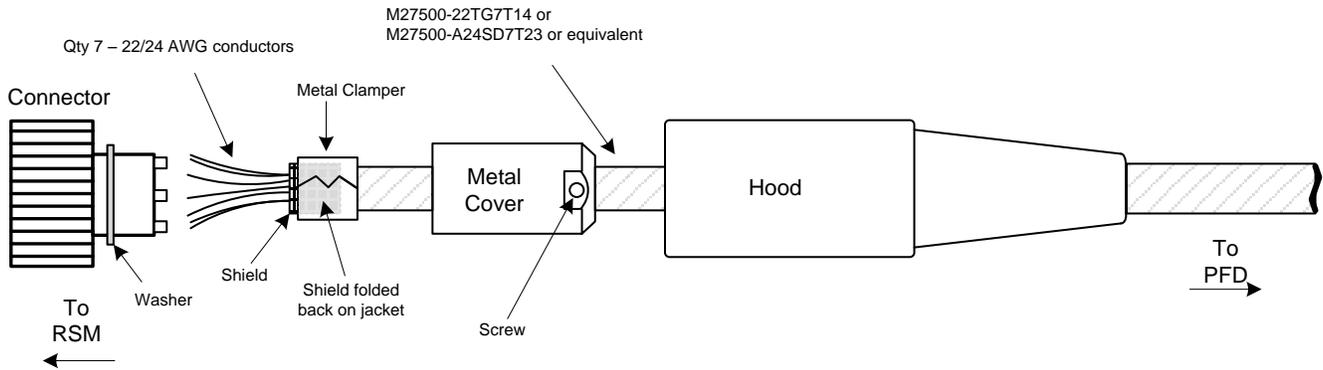

Figure 7-2: RSM Connector assembly

**CAUTION:** Do not run RSM wiring near high current devices such as strobes and air conditioners and avoid running RSM wiring in same wire bundle as strobe and air conditioning wiring bundles if at all practical.

7.2.6.3 EFD END

Terminate the shield at the EFD end inside the back shell. Attach pigtail ground wire to shield and connect to ground screw as shown in Figure 7-3.

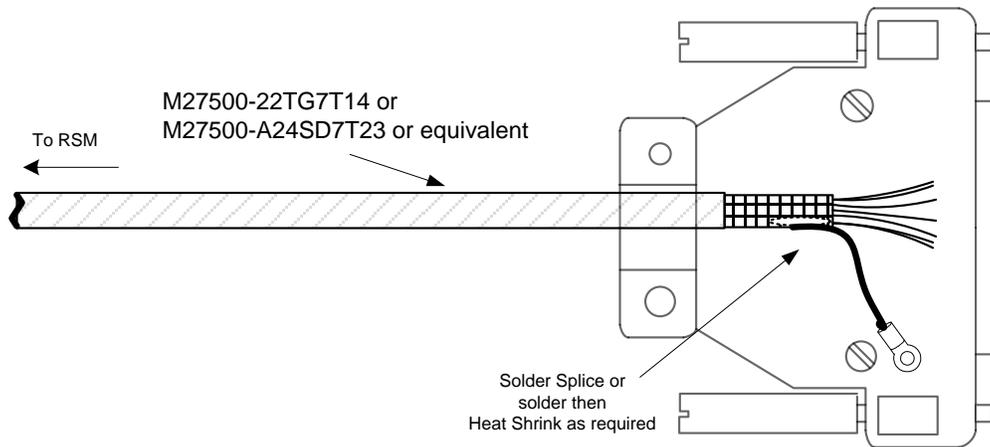

Figure 7-3: EFD Back Shell Grounds/RSM

7.2.7 Configuration Module Wiring

The Configuration Module (CM) connector comes as an assembly with color-coded wires within an over braid. The wires are inserted into the appropriate pins as shown in Figure 9-1. The green wire with ground lug is attached to back shell.

EFD Pin	Color	CM Pin
41	Black	1
42	Brown	2
43	Orange	4
44	Red	3
--	Green	5

Table 7-2: CM Wiring

### **7.2.8 ACU Wiring**

Wire the ACU as shown in Section 9 keeping all grounds as short as possible. No additional HIRF shielding is required. The ACU case must be grounded to airframe ground for proper operation.

### **7.2.9 Back Up NAV Indicator Wiring**

Wire the NAV indicator as shown in Figures 9-24, 9-25, and 9-26. Do not parallel more than one NAV Indicator to each ACU. When paralleling the wiring make the splice as close to the navigation receiver as practical. Do not splice the connection at the back of the NAV indicator.

### **7.2.10 Autopilot Wiring**

Wire the autopilot to ACU as shown in Section 9. Remove any existing connections and switching between GPS and NAV receivers to autopilot. Only ARINC 429 wiring may remain between the GPS and autopilot for NAV mode GPSS. The ACU will perform all switching functions to autopilot for GPS1 and NAV1.

### **7.2.11 Backup Instrument Wiring and Cable bundle**

Any existing wiring/cabling or tubing going to or coming from the backup turn and slip, altimeter or the airspeed indicator must not route directly behind the rear of the EFD1000 E5 display head. Ensure it is secured away and below the display head fan assembly.

THIS PAGE IS INTENTIONALLY LEFT BLANK

## 8 Electrical Connections

### 8.1 EFD Electrical Specifications

#### 8.1.1 Power Input

Nominal Input: ..... 14Vdc or 28Vdc

Operating Range: ..... 9Vdc to 32Vdc (Note: Input power must transition >11VDC to turn on the unit)

#### 8.1.2 RS-232 GPS Input

Data is accepted in packets coded in the industry standard "avionics" format at a baud rate of 9600, 8 data bits, 1 stop bit, no parity. Packets are accepted at approximately 1 Hz.

The following GPS configuration options are available in the Installation menu:

- GPS TYPE 1 – KLN94 and KLN90B Standard RS-232 configuration.
- GPS TYPE 2 – KLN94 Enhanced configuration. Allows the KLN94 to be configured for Enhanced RS-232.
- GPS TYPE 3 – GX-50/55/60/65 configuration.

#### 8.1.3 RS-232 ADC Output

The EFD1000 E5 Display outputs the following computed air data output signals over the RS-232 bus in Format Z (Shadin) (ADC TYPE 1) and Format C (Bendix King) (ADC TYPE 2):

Label	ADC TYPE 1	ADC TYPE 2
Indicated Air Speed	X	X
Pressure Altitude	X	X
Rate of Turn <sup>(1)</sup>	X	
Vertical Speed	X	X
Heading Data	X	X
(1) This output is invalid when in "Degraded" mode		

*Table 8-1: RS-232 ADC Outputs*

#### 8.1.4 ARINC 429 GPS Inputs

The EFD receives the following labels on pins (16, 17) and (20, 21) when transmitted from a GPS receiver. ARINC 429 word definitions are implemented per GAMA Pub 11. The GPS input ports can be configured either HIGH or LOW.

ARINC Label(s)	EFD Parameter
074	Data Record Header
075, bit 9 set	OBS/HOLD Mode
075, bit 9 not set	Auto Course Select
Label 100, bits 13(0) and 12(1)	CDI Select (GPS) [GNAV installation only]
Label 100, bits 13(1) and 12(0)	CDI Select (VLOC) [GNAV installation only]
Label 114	GPS "Desired Track"
Label 115	GPS "Waypoint Bearing"
Label 116	GPS "Crosstrack"

ARINC Label(s)	EFD Parameter
Label 117	GPS "Vertical Deviation"
Label 147	GPS "Magnetic Variation"
Label 121	GPS "Horizontal Command"
Label 251	GPS "Distance to Go"
Label 252	GPS "Time to Go"
Label 275, bit 23	GPS "TO" Flag
Label 275, bit 24	GPS "FROM" Flag
Label 312	GPS "Ground Speed"
Label 313	GPS "Track"
Label 326	GPS "Lateral Deviation Scale Factor" full precision
Label 327	GPS "Vertical Deviation Scale Factor" full precision

**Table 8-2: EFD A429 GPS Input**

**8.1.5 ARINC 429 VLOC Input**

The EFD receives the following labels on Pins (18, 19) and (22, 23) when transmitted from a VLOC receiver. The VLOC input ports can be configured either HIGH or LOW.

ARINC (Label)	EFD Parameter
Label 34	Tuned Frequency
Label 34, bit 14 set	ILS Energize
Label 173	Localizer deviation and validity flags
Label 174	Glide Slope deviation and validity flags
Label 222	VOR Omni bearing

**Table 8-3: EFD A429 VLOC Input**

**8.1.6 ARINC 429 Output**

The EFD1000 E5 transmits the following labels on pins 26 and 27 (Note – some labels are only transmitted when configured for an ACU installation). Labels 350 and 354 are proprietary ACU labels and should not be used for any purpose by any other third party device.

*Note – When connecting any third party device to this output it is the installer’s responsibility to verify that the connected device does not have any adverse effects from the labels below.*

*Note – The labels below are non-standard ARINC or GAMA labels due solely to the rate at which the label is being transmitted.*

*Note– Except as shown in the wiring diagrams (Section 9) no ARINC 429 interface is approved under the Aspen STC, and must be approved separately.*

ARINC Label	EFD Parameter	ARINC Transmit Rate*
100 <sup>(1)</sup>	Selected Course	200ms
105	Heading Datum	50ms
173	Lateral Deviation	50ms

ARINC Label	EFD Parameter	ARINC Transmit Rate*
174	Vertical Deviation	50ms
203 <sup>(1)</sup>	Pressure Altitude	200ms
204 <sup>(1)</sup>	Pressure Altitude (Baro corrected)	200ms
235	Baro Correction (inHg)	50ms
261G, bit 14	ILS Energize	50ms
261G, bit 15	GPS/NAV Select	50ms
261G, bit 16	Back Course	50ms
261G, bit 28	Altitude Engage	50ms
277	Course Datum	50ms
320 <sup>(1)</sup>	Magnetic Heading	50ms
350	ACU Config	1000m
354	ACU Config	1000ms
(1) These labels are the only ones transmitted when no ACU is configured.		
*The label rate has a tolerance of +/- 15%		

**Table 8-4: EFD1000 E5 A429 GPS Output**

**8.2 ACU Electrical Specifications (910-00004 all dash numbers)**

**8.2.1 Power Input**

Nominal Input: ..... 14Vdc or 28Vdc

Operating Range: ..... 11Vdc to 32Vdc

**8.2.2 Reserved**

**8.2.3 VLOC Receiver**

**8.2.3.1 NAV Composite Input**

An input connected to the composite output of a VHF Navigation receiver.

Nominal Input: ..... 0.5Vrms VOR

..... 0.35Vrms Localizer

Input Impedance: ..... 100K ohms

**8.2.3.2 ILS Energize Discrete Input**

Low impedance to ground supplied from a Navigation receiver when it is tuned to a localizer frequency.

Active:..... Less than 500 ohms to ground or less than 1.5Vdc

Inactive: ..... Open circuit sinking less than 1 ma to ground at 28Vdc

**8.2.3.3 Glide Slope Deviation Input**

A low level differential input that accepts a glide slope signal from an external VHF Nav receiver.

Input Range: ..... ±150mVdc full scale

Max Input Range: ..... ±400mVdc

Load: ..... 1000 ohm

**8.2.3.4 Glide Slope Flag Input**

A low level valid input from an external VHF Navigation receiver.  
 Valid: ..... Greater than 260mV across a 1000-ohm load  
 Invalid:..... Less than 100mV across a 1000 ohm load

**8.2.4 GPS Receiver**

**8.2.4.1 OBS Sine, Cosine, Rotor**

An OBS resolver output for GPS receivers that require an OBS input. The resolver output electrical zero is set to +60° (300° ORZ) for compatibility with most legacy resolvers. The ACU accommodates OBS excitation with DC offset.  
 Excitation Amplitude: .... 5Vac min to 26Vac max (H to C)  
 Excitation Frequency: .... 30Hz to 5000Hz  
 Output Format: ..... Sine (D and E), Cosine (F and G)  
 Output Gradient: ..... Excitation \* 0.401 (26Vac in = 10.4Vac out)  
 DC Offset: ..... 0Vdc to +5Vdc (Offset applied to Rotor C)

**8.2.4.2 TO/ FROM FLAG Input**

Differential input from a GPS receiver indicating whether flying TO or FROM the active waypoint.  
 TO the waypoint: ..... +40mV or greater  
 FROM the waypoint: ..... -40mV or greater

**8.2.4.3 LEFT/ RIGHT Input**

Differential input from a GPS receiver indicating LEFT or RIGHT of GPS course.  
 Input Range: ..... ±150mVdc full scale  
 Load: ..... 1000 ohm

**8.2.4.4 Lateral Flag Input**

Validity flag from the GPS receiver indicating valid LEFT and RIGHT data.  
 Valid: ..... 260mV to 800mVdc  
 Invalid:..... Less than 260mVdc

**8.2.4.5 Vertical Deviation Input**

Differential input from a GPS receiver indicating a fly UP or DOWN command.  
 Input Range: ..... ±150mVdc full scale  
 Load: ..... 1000 ohm

**8.2.4.6 Vertical Deviation Flag Input**

Validity flag from the GPS receiver indicating valid UP and DOWN data.  
 Valid: ..... 260mV to 800mVdc  
 Invalid:..... Less than 260mVdc

**8.2.4.7 OBS/ LEG (HOLD) Input**

Active low discrete input from a GPS receiver when in the OBS or HOLD mode.

**8.2.4.8 APPR Active Input**

Active low discrete input from a GPS receiver when approach mode is activated.

**8.2.4.9 FCS-LOC Engage Input**

Active low discrete input from a GPS receiver when approach is selected.

**8.2.5 Autopilot**

**8.2.5.1 Lateral Deviation Output**

A low-level lateral deviation output that is connected to an autopilot lateral deviation (RT/LT) input. The low side of the differential output is referenced to ground. Before connecting this output verify the receiving equipment’s left/right input can accommodate a ground potential on the low side.

Lateral Deviation: ..... ±150mVdc minimum for full scale CDI deflection

Sense: ..... Positive voltage for fly right

Load: ..... Will drive up to three 1000 ohm loads

**8.2.5.2 Lateral Flag Output**

A low level valid output to the autopilot indicating the Lateral (LT/RT) signal from the ACU is valid.

Valid: ..... 0.4 to 0.8Vdc

Invalid: ..... Less than 0.05Vdc

Load: ..... Will drive up to three 1000 ohm loads

***NOTE – ACU2 P/N 910-00004-102 does not have a low level flag. It provides a discrete to ground for energizing an external superflag relay.***

**8.2.5.3 Vertical Deviation Output**

A low level vertical deviation output that is connected to an autopilot vertical (UP/DN) input. The low side of the differential output is referenced to ground.

Output Voltage: ..... ±150mVdc nominal, tracks the glide slope deviation input signal to within 5%

Loading: ..... Up to three 1000-ohm loads

**8.2.5.4 Vertical Flag Output**

A low level output to the autopilot indicating the UP/DN from the ACU is valid.

Valid: ..... 0.4 to 0.8Vdc

Invalid: ..... Less than 0.05Vdc

Load: ..... Will drive up to three 1000-ohm loads

***NOTE – ACU2 P/N 910-00004-102 does not have a low level flag. It provides a discrete to ground for energizing an external superflag relay.***

**8.2.5.5 ILS Energize Output**

Active low output to an autopilot when an ILS is selected or GPS approach is active.

ILS/GPS APPR Active: ..... Sink to ground

ILS/GPS APPR Inactive: ... Open

Load Current: ..... 100ma maximum

8.2.5.6 Volt Reference Output

An internally generated +15Vdc reference for KI-525 emulation.

Output Voltage:..... +15Vdc ±2Vdc

Load Current:..... 30ma maximum

8.2.5.7 KI-525A Heading and Course Datum Output

Emulated KI-525A outputs to drive the heading and course datum inputs of an autopilot.

BENDIX KING KI525A EMULATION ACU HSI TYPE = 0			
<sup>1</sup> DATUM	SCALING	<sup>2</sup> REFERENCE VOLTAGE ACU P3-23	DESCRIPTION (with ACU DATUM = NORMAL)
HDG ACU P3-22	500mVdc per degree up to a maximum angle of 30°, or 15Vdc.	15Vdc	500mVdc per degree up to a maximum angle of 30°, or 15Vdc. The output remains at +15Vdc from 31° to 180°. At 181° it switches to -15Vdc. Likewise for negative angles (HDG bug left of the lubber line) the gradient is -500mVdc per degree up to -30°. The output remains at -15Vdc from -31° to -179°. At 180° it switches to +15Vdc.
CRS ACU P3-3	167mVdc per degree up to 90°, or 15Vdc.	15Vdc	167mVdc per degree up to 90°, or +15Vdc. From 91° to 180° the output diminishes by 167mVdc per degree, reaching 0Vdc at 180°. For negative angles (CRS pointer left of the lubber line) the gradient is -167mVdc per degree up to -90°. From -90° to -179° the output diminishes by 167mVdc per degree reaching 0Vdc at 180°.
<sup>1</sup> Datum outputs are in reference to ACU P3-11, ACU reference ground. <sup>2</sup> 15Vdc reference may come from ACU P3-9, ACU +15Vdc Out.			

Table 8-5: KI525A Emulation Specifications

8.2.5.8 NSD-360 Heading and Course Datum Output

Emulated NSD-360 outputs to drive the heading and course datum inputs of an autopilot.

NSD-360 EMULATION ACU HSI TYPE = 1			
<sup>1</sup> DATUM	SCALING	<sup>2</sup> REFERENCE VOLTAGE ACU P3-23	DESCRIPTION (with ACU DATUM = NORMAL)
HDG ACU P3-22	167mVdc per degree up to 90°, or 15Vdc.	15Vdc Reference voltage may be any positive DC or AC reference voltage	Assuming a reference voltage of 15Vdc, the gradient is 167mVdc per degree up to 90°, or +15Vdc. From 91° to 180° the output diminishes by 167mVdc per degree, reaching 0Vdc at 180°. For negative angles (HDG Bug left of the lubber line) the gradient is -167mVdc per degree up to -90°. From -90° to -179° the output diminishes by 167mVdc per degree reaching 0Vdc at 180°.

CRS ACU P3-3	167mVdc per degree up to 90°, or 15Vdc.	15Vdc Reference voltage may be any positive DC or AC reference voltage	Assuming a reference voltage of +15Vdc, the gradient is 167mVdc per degree up to 90°, or +15Vdc. From 91° to 180° the output diminishes by 167mVdc per degree, reaching 0Vdc at 180°. For negative angles (CRS pointer left of the lubber line) the gradient is -167mVdc per degree up to -90°. From -90° to -179° the output diminishes by 167mVdc per degree reaching 0Vdc at 180°.
<sup>1</sup> Datum outputs are in reference to ACU P3-11, ACU reference ground. <sup>2</sup> Reference voltage typically comes from autopilot computer.			

**Table 8-6: NSD360A Emulation Specifications**

**8.2.5.9 PN-101 Heading and Course Datum Output**

Emulated PN-101 outputs to drive the heading and course datum inputs of an autopilot.

PN-101 EMULATION ACU HSI TYPE = 3			
<sup>1</sup> DATUM	SCALING	<sup>2</sup> REFERENCE VOLTAGE ACU P3-21	DESCRIPTION (with ACU DATUM = NORMAL)
HDG ACU P3-22	The gradient is scaled to 11.8Vac maximum at 90° when using a 26Vac reference. It is linear between 0° and 90°.	26Vac Reference voltage may be any AC reference voltage	Assuming a reference voltage of 26Vac, the gradient is 131mVac per degree up to 90°, or 11.8Vac. From 91° to 180° the output diminishes by 131mVac per degree, reaching 0Vac at 180°. For negative angles (HDG Bug left of the lubber line) the gradient is out of phase with the reference and is 131mVac per degree up to -90°. From -90° to -179° the output diminishes by 131mVac per degree reaching 0Vdc at 180°.
CRS ACU P3-3	The gradient is scaled to 11.8Vac maximum at 90° when using a 26Vac reference. It is linear between 0° and 90°.	26Vac Reference voltage may be any AC reference voltage	Assuming a reference voltage of 26Vac, the gradient is 131mVac per degree up to 90°, or 11.8Vac. From 91° to 180° the output diminishes by 131mVac per degree, reaching 0Vac at 180°. For negative angles (HDG Bug left of the lubber line) the gradient is out of phase with the reference and is 131mVac per degree up to -90°. From -90° to -179° the output diminishes by 131mVac per degree reaching 0Vdc at 180°.
<sup>1</sup> Datum outputs are in reference to ACU P3-11, ACU reference ground. <sup>2</sup> Reference voltage typically comes from autopilot computer or aircraft inverter.			

**Table 8-7: PN101 Emulation Specifications**

**8.2.5.10 Heading Valid Output**

Active low discrete output indicating the EFD directional gyro is valid.

Valid: ..... Sinks to ground

Invalid: ..... Open

Load Current: ..... 100ma maximum

**8.2.5.11 GPS Selected Output**

Active low discrete output indicating GPS1 or GPS2 is the current coupled sensor on the HSI.

GPS coupled: ..... Sinks to ground

GPS not coupled: ..... Open

Load Current: ..... 100ma maximum

**8.2.5.12 ARINC 429 Output**

The ACU transmits the following labels on P3 pins 4 and 5 for GPS receivers and systems that require ARINC 429 magnetic heading and selected course.

*Note- Except as shown in the wiring diagrams (Section 9) no ARINC 429 interface is approved under the Aspen STC, and must be approved separately.*

ARINC Label	EFD Data	Rate (ms)
100	Selected Course	200
320	Magnetic Heading	200

*Table 8-8: ACU A429 Output*

**8.3 ACU2 Electrical Specifications (910-00004-10x only)**

The ACU2 has the same interfaces as the ACU above on connectors J1 /J2/J3 plus it adds the following interfaces on connector J4.

**8.3.1 Heading Synchro Out**

The ACU2 will output a heading synchro (bootstrap) signal per ARINC 407 to external equipment.

Heading Reference In:

Input Range: ..... 17Vac to 30Vac

Frequency Range: ..... 300Hz to 5500Hz

Load: ..... at least 68100 ohm

Heading Reference Out:

Output Voltage: ..... 17Vac to 30Vac (26Vrms nominal) into a 10000 ohm load

Frequency Range: ..... 350Hz to 450Hz

Load: ..... 10000 ohm

Synchro Output:

Output Format: .....  $V_{X-Z} = V_{Ref} \sin(\Theta - 120^\circ)$

$V_{Y-Z} = V_{Ref} \sin(\Theta + 120^\circ)$

Output Range: ..... 0 to 11.8Vrms

The ACU2 will disable the heading reference output when an external reference of greater than 18Vac is applied across pins 26V-REF-H and 26V-REF-C.

Heading Valid:

Open Collector output to the heading valid flag. It can sink up to 100mA to ground at 28Vdc.

**8.3.2 +/- 15Vdc Power Output**

The ACU2 outputs +15Vdc and -15Vdc to external equipment such as a Bendix King KA-52/57.

+15 Range: ..... +14Vdc to +15.5Vdc at up to 150mA

-15 Range: ..... -14Vdc to -15.5Vdc at up to 150mA

**8.3.3 Glideslope Flag (Narco)**

The ACU2 provides a high impedance (10K) glideslope flag input for use with Narco and other NAV radios unable to drive the standard 1k load.

Valid: ..... Greater than 260mV across a 10000-ohm load

Invalid: ..... Less than 100mV across a 10000 ohm load

**8.3.4 ARINC 429 Output**

The ACU2 transmits the following labels on J3-4/J3-5 (TX2) for GPS receivers and systems that require ARINC 429 magnetic heading, air data and selected course. Can be configured High or Low speed.

*Note- Except as shown in the wiring diagrams (Section 9) no ARINC 429 interface is approved under the Aspen STC, and must be approved separately.*

ARINC Label	EFD Data	Rate (ms)
100	Selected Course	200
320	Magnetic Heading	200
203	Pressure Altitude	200
204	Baro Corrected Altitude	200

*Table 8-9: ACU2 ARINC 429 Output*

**8.4 EFD Pin Out**

Pin Number	Name	Input / Output	Function
1	POWER	-	Main DC power input
2	POWER	-	"
3	POWER	-	"
4	GND	-	Main DC ground
5	GND	-	"
6	GND	-	"
7	Digital Discrete	OUTPUT	n/a
8	RS-232RX1	INPUT	RS-232 RX1 (115kb)
9	RS-232RX2	INPUT	RS-232 RX2
10	RS-232RX3	INPUT	RS-232 RX3
11	RS-232RX4	INPUT	RS-232 RX4
12	RS-232RX5	INPUT	RS-232 RX5
13	RS-232TX1	OUTPUT	RS-232 TX1
14	RS-232TX2	OUTPUT	RS-232 TX2
15	RS-232TX3	OUTPUT	RS-232 TX3
16	ARINCRX1A	INPUT	ARINC Receiver 1
17	ARINCRX1B	INPUT	ARINC Receiver 1
18	ARINCRX2A	INPUT	ARINC Receiver 2
19	ARINCRX2B	INPUT	ARINC Receiver 2

Pin Number	Name	Input / Output	Function
20	ARINCRX3A	INPUT	ARINC Receiver 3
21	ARINCRX3B	INPUT	ARINC Receiver 3
22	ARINCRX4A	INPUT	ARINC Receiver 4
23	ARINCRX4B	INPUT	ARINC Receiver 4
24	ARINCRX5A	INPUT	ARINC Receiver 5
25	ARINCRX5B	INPUT	ARINC Receiver 5
26	ARINCTX1A	OUTPUT	ARINC Transmitter 1
27	ARINCTX1B	OUTPUT	ARINC Transmitter 1
28	Reserved	-	Future Expansion
29	Reserved	-	"
30	RS-232TX0	OUTPUT	RS-232 TX
31	RS-232RX0	INPUT	RS-232 RX0 (115kb)
32	RSMC	-	RSM data
33	RSMD	-	RSM data
34	RSME	-	RSM data
35	RSMF	-	RSM data
36	RSMG	-	RSM data
37	ENET TX+	OUTPUT	Ethernet TX bus
38	ENET TX-	OUTPUT	Ethernet TX bus
39	ENET RX+	INPUT	Ethernet RX bus
40	ENET RX-	INPUT	Ethernet RX bus
41	CONFIGA	-	Configuration Module connection
42	CONFIGB	-	"
43	CONFIGC	-	"
44	CONFIGD	-	"

Table 8-10: EFD Pin Out

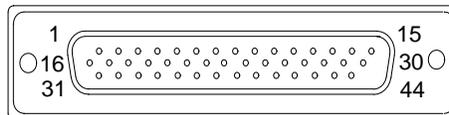

Figure 8-1: EFD Connector (as viewed from rear of unit)

### 8.5 RSM Pin Out

Pin Number	Name	Input / Output	Function
1	RSMA	-	RSM Connection
2	RSMB	-	RSM Connection
3	RSMC	-	RSM Connection
4	RSMD	-	RSM Connection
5	RSME	-	RSM Connection
6	RSMF	-	RSM Connection
7	RSMG	-	RSM Connection

Table 8-11: RSM Pin Out



Figure 8-2: RSM Mating Connector -Install Side

### 8.6 Configuration Module Pin Out

Pin Number	Name	Input / Output	Function
1	ConfigA	-	CM Connection
2	ConfigB	-	CM Connection
3	ConfigD	-	CM Connection
4	ConfigC	-	CM Connection
5	ConfigS	-	Shield Ground

Table 8-12: Configuration Module Pin Out

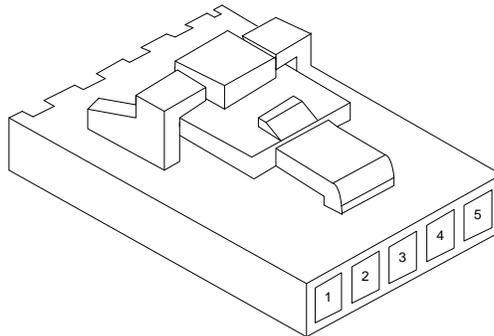

Figure 8-3: Configuration Module Connector (Install side)

8.7 ACU/ACU2 Pin Out

Pin Number	Name	Input / Output	Function
J1-1	429RX2A	INPUT	ARINC 429 Port 2 Receive A
J1-2	429RX2B	INPUT	ARINC 429 Port 2 Receive B
J1-3	PWR-COM	-	Power Common
J1-4	GPS+LT	INPUT	GPS Lateral Dev Input (-)
J1-5	GPS-LATFLG	INPUT	GPS Lateral Flag Input (-)
J1-6	GPS+DN	INPUT	GPS Vertical Dev Input (-)
J1-7	GPS+FR	INPUT	GPS TO/FROM Input
J1-8	GPS-VERTFLG	INPUT	GPS Vertical Dev Flag (-)
J1-9	Reserved	-	Reserved
J1-10	+11 to 32Vdc	-	Aircraft Primary Power
J1-11	GPS+RT	INPUT	GPS Lateral Dev Input (+)
J1-12	GPS+LATFLG	INPUT	GPS Lateral Flag Input (+)
J1-13	GPS+UP	INPUT	GPS Vertical Dev Input (+)
J1-14	GPS+TO	INPUT	GPS TO/FROM Input
J1-15	GPS+VERTFLG	INPUT	GPS Vertical Flag (+)

Table 8-13: ACU J1 Pin Out

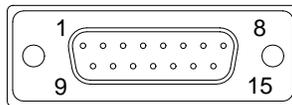

Figure 8-4: ACU J1 Connector (as viewed from front of unit)

Pin Number	Name	Input / Output	Function
J2-1	COMPOSITE	INPUT	VOR/LOC Composite input
J2-2	/ILS-ENERGIZE	INPUT	Active Low input from VHF Nav Rx
J2-3	/Spare-Disc1	INPUT	Spare Discrete Input
J2-4 <sup>1</sup>	/BACK-CRS-OUT	OUTPUT	Open collector output to drive the back course sense circuit of an autopilot
J2-5	/ILS-ENERGIZE-OUT	OUTPUT	Active Low Output when ILS Selected or GPS Appr Active
J2-6	/FCS-LOC-IN	INPUT	Low Input from GPS when Appr Selected
J2-7	/OBS-LEG-IN	INPUT	Active Low from GPS when GPS OBS mode selected
J2-8	-DH	INPUT	N/A
J2-9	FD-ENGAGED	INPUT	N/A
J2-10	FD-ROLL2	INPUT	N/A
J2-11	+VLOCFLG-OUT	OUTPUT	Valid VHF Nav VOR or Localizer signal
J2-12	+GS-IN	INPUT	Glideslope deviation from VHF Nav Rx

Pin Number	Name	Input / Output	Function
J2-13	+GSFLG-IN	INPUT	Glideslope flag from VHF Nav Rx
J2-14	FD-PITCH-COM	INPUT	N/A
J2-15	FD-ROLL-COM	INPUT	N/A
J2-16	+UP	OUTPUT	Vertical output to autopilot (H)
J2-17	+VERT-FLG	OUTPUT	Vertical output flag (H)
J2-18	+RT	OUTPUT	Lateral deviation output
J2-19	ACU #1/#2	INPUT	Spare Discrete Input
J2-20	COMPOSITE-COM	-	VOR/LOC common
J2-21	Reserved	-	Spare Discrete Input
J2-22	Reserved	-	Spare Discrete Input
J2-23	Reserved	-	Reserved
J2-24	APPR-ACT	INPUT	Active Low input from GPS when GPS approach mode activated
J2-25 <sup>1</sup>	HEADING VALID	OUTPUT	Active Low Output when Heading Valid
J2-26	+DH	INPUT	N/A
J2-27	FD-VALID	INPUT	N/A
J2-28	FD-PITCH2	INPUT	N/A
J2-29	ALT ENGAGE	OUTPUT	N/A
J2-30	-VLOCFLG-OUT	-	Common
J2-31	-GS-IN	INPUT	Glideslope deviation from VHF Nav Rx
J2-32	-GSFLG-IN	INPUT	Glideslope flag from VHF Nav Rx
J2-33	FD-PITCH1	INPUT	N/A
J2-34	FD-ROLL1	INPUT	N/A
J2-35	+DN	OUTPUT	Vertical output to autopilot (L)
J2-36	-VERT-FLG	OUTPUT	Vertical output flag (L)
J2-37	+LT	OUTPUT	Lateral deviation output

Table 8-14: ACU J2 Pin Out

<sup>1</sup>NOTE - On ACU2 P/N 910-00004-102, J2-4 is a NAV Flag Discrete and J2-25 is a Glide Slope Flag Discrete used on autopilots that require a superflag input.

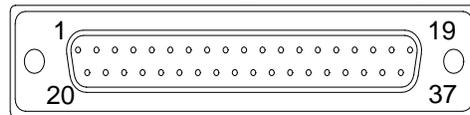

Figure 8-5: ACU J2 Connector (as viewed from front of unit)

Pin Number	Name	Input / Output	Function
J3-1	429RX1A	INPUT	ARINC 429 Port 1 Receive A
J3-2	429TX1A	OUTPUT	ARINC 429 Port 1 Transmit A
J3-3	CRS-DATUM	OUTPUT	Course Datum output

Pin Number	Name	Input / Output	Function
J3-4	429TX2A	OUTPUT	ARINC 429 Port 2 Transmit A
J3-5	429TX2B	OUTPUT	ARINC 429 Port 2 Transmit B
J3-6	OBS SIN -	OUTPUT	Sin of selected course angle (L)
J3-7	OBS COS -	OUTPUT	Cos of selected course angle (L)
J3-8	ROTOR C	OUTPUT	OBS sin/cos excitation (L)
J3-9	+15V-EXT-OUT	OUTPUT	Internal +15Vdc reference
J3-10	SIGNAL-COM	-	Signal ground
J3-11	HDG/CRS-COM	-	Signal ground
J3-12	Reserved	-	Reserved
J3-13	Reserved	-	Reserved
J3-14	429RX1B	INPUT	ARINC 429 Port 1 Receive B
J3-15	429TX1B	OUTPUT	ARINC 429 Port 1 Transmit B
J3-16	SIGNAL-COM	-	Signal ground
J3-17	GPS SELECTED	OUTPUT	Active Low signal to drive GPS and Autopilot inputs.
J3-18	OBS SIN +	OUTPUT	Sin of selected course angle (H)
J3-19	OBS COS +	OUTPUT	Cos of selected course angle(H)
J3-20	ROTOR H	INPUT	OBS sin/cos excitation (H)
J3-21	ARINC-HDG-CRS-EXT	-	26Vac reference to emulate an ARINC synchro interface
J3-22	HDG-DATUM	OUTPUT	Heading Datum output
J3-23	HDG-CRS-DATUM-EXT	INPUT	Heading/Course Datum excitation input
J3-24	Reserved	-	Reserved
J3-25	HDG-CRS-OFST	INPUT	Heading/Course Datum excitation offset input

Table 8-15: ACU J3 Pin Out

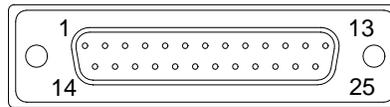

Figure 8-6: ACU J3 Connector (as viewed from front of unit)

Pin Number	Name	Input / Output	Function
J4-1	+15VDC Out	OUTPUT	15Vdc power to external equipment
J4-2	429TX3B	OUTPUT	ARINC 429 Port 3 Transmit B
J4-3	429RX3B	INPUT	ARINC 429 Port 3 Receive B
J4-4	400HZ-REF-LO	OUTPUT	400Hz excitation for heading synchro
J4-5	HDG Y	OUTPUT	Heading synchro (Y-Z)
J4-6	DME1-DATA +8V	INPUT	N/A

Pin Number	Name	Input / Output	Function
J4-7	DME1-CLK +8V	INPUT	N/A
J4-8	DME2-GATE +8V	INPUT	N/A
J4-9	DME-COM	INPUT	N/A
J4-10	ADF1 +REF	INPUT	N/A
J4-11	OAT +5	OUTPUT	N/A
J4-12	ADF2 +REF	INPUT	N/A
J4-13	OATSIG	INPUT	N/A
J4-14	422TX1 +	OUTPUT	RS-422 Port 1 Serial Data Out
J4-15	422TX2 +	OUTPUT	RS-422 Port 2 Serial Data Out
J4-16	422RX1B	INPUT	RS-422 Port 1 Serial Data In, or RS-232 RX1
J4-17	422RX2A	INPUT	RS-422 Port 2 Serial Data In
J4-18	/DISC1	OUTPUT	N/A
J4-19	/DISC3	OUTPUT	Active Low Discrete Output
J4-20	+RADALT	INPUT	N/A
J4-21	RADALT-VLD	INPUT	N/A
J4-22	-15VDC OUT	OUTPUT	-15Vdc Output for external equipment
J4-23	429TX3A	OUTPUT	ARINC 429 Port 3 Transmit A
J4-24	429RX3A	INPUT	ARINC 429 Port 3 Receive A
J4-25	400HZ-REF-HI	OUTPUT	400Hz excitation for heading synchro
J4-26	HDG-X	OUTPUT	Heading synchro output (X-Z)
J4-27	HDG-Z	OUTPUT	Heading synchro output (Z)
J4-28	DME1-GATE +8V	INPUT	N/A
J4-29	DME2-DATA +8V	INPUT	N/A
J4-30	DME2-CLK +8V	INPUT	N/A
J4-31	ADF1 +SIN	INPUT	N/A
J4-32	ADF1 +COS	INPUT	N/A
J4-33	ADF2 +SIN	INPUT	N/A
J4-34	ADF2 +COS	INPUT	N/A
J4-35	422TX1 -	OUTPUT	RS-422 Port 1 Serial Data Out, or RS-232 TX1
J4-36	422TX2 -	OUTPUT	RS-422 Port 2 Serial Data Out, or RS-232 TX2
J4-37	422RX1A	INPUT	RS-422 Port 1 Serial Data In
J4-38	232/422 SERIAL COM	-	Chassis Ground
J4-39*	422RX2B	INPUT	RS-422 Port 2 Serial Data In, or RS-232 RX2
J4-40	/DISC2	OUTPUT	N/A
J4-41	/DISC4	OUTPUT	Active Low Discrete Output
J4-42	-RADALT	INPUT	N/A
J4-43	ANN-LOAD	INPUT	N/A
J4-44	/SPARE-DISC3	INPUT	Discrete Input
J4-45	/SPARE-DISC4	INPUT	Discrete Input

Pin Number	Name	Input / Output	Function
J4-46	/SPARE-DISC5	-	Discrete Input or Output
J4-47	/SPARE-DISC6	-	Discrete Input or Output
J4-48	/SPARE-DISC7	-	Discrete Input or Output
J4-49	/SPARE-DISC8	-	Discrete Input or Output
J4-50	/SPARE-DISC9	INPUT	Discrete Input
J4-51	/SPARE-DISC10	INPUT	Discrete Input
J4-52	/SYN-HDG-VALID	OUTPUT	Active Low output when synchro Hdg Valid
J4-53	MK12D-GS+FLG	INPUT	High impedance Glideslope Flag (Narco)
J4-54	MK12D-GS-FLG	INPUT	High impedance Glideslope Flag (Narco)
J4-55	ANN-CLK	INPUT	N/A
J4-56	ANN-DATA	INPUT	N/A
J4-57	VSC-REF	INPUT	N/A
J4-58	VSC	OUTPUT	N/A
J4-59	VSC-COM	-	N/A
J4-60	26V-REF-H	INPUT	26V Heading Synchro Reference In
J4-61	26V-REF-C	INPUT	26V Heading Synchro Reference In
J4-62	BARO-OUT	OUTPUT	Baro Correction Output (0-5Vdc)

Table 8-19: ACU J4 Pin Out (ACU2 only)

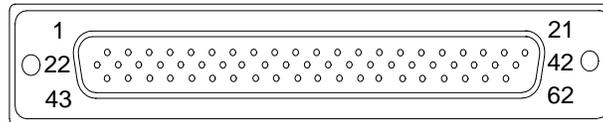

Figure 8-7: ACU2 J4 Connector (ACU2 only)

## 9 Installation Wiring Diagrams

The following Section contains wiring diagrams for common interfacing equipment to the EFD, ACU, RSM, and Configuration Module. Although the list of interfacing equipment is quite extensive it does not cover all compatible equipment. For interfaces that are installed but not shown it is required by the ICAs that a drawing be made and inserted into the Instructions for Continued Airworthiness. All other drawings used from this section by the installer must be copied and inserted into the ICA's.

There will be some GPS receivers not shown on these drawings that will be compatible with the EFD1000 E5 system. The EFD1000 E5 is compatible with ARINC 429, RS-232, and analog GPS receivers. It will be up to the installer to verify the interface is fully functional by performing a complete GPS manufacturer's ground check of the system.

There are also VLOC receivers not shown in these drawings that can be connected either by ARINC 429 to the EFD or through VOR composite video into the ACU or ACU2. Any radio with a nominal output of 0.5Vrms VOR or 0.35Vrms Localizer composite video format are supported. It will be up to the installer to verify the interface is fully functional by performing a complete VOR manufacturer's ground check of the system.

The EFD1000 E5 with ACU or ACU2 emulates a Bendix King KI-525A, a NSD-360A, and a PN-101 HSI by providing outputs for HDG Datum and CRS Datum to an autopilot. The EFD1000 E5 is compatible with any autopilot that is compatible with a KI-525A, NSD-360A, or PN-101 HSI. Should connections be made to an autopilot not shown in these drawings the installer must verify the interface is fully functional by performing a complete ground and flight check of the system per the autopilot manufacturer's installation manual or maintenance instructions.

To begin planning the electrical installation, select the drawing in the list below preceded by an asterisk, "\*", that matches the aircraft equipment configuration, and then wire as shown. NAV1 and the autopilot are options on each page. Simply make the connections to the equipment you plan to install and omit the units from the drawing you don't. You will configure the system later based upon the Configuration ID#s shown in the Configuration Matrix on each drawing. Aspen Avionics Inc. uses the terms "GNAV" when referring to a combination GPS/VLOC Receiver with an integral CDI source select (i.e., GNS-430), "GPS" for a standalone GPS Receiver (i.e., GNS-400, KLN90B), and "VLOC" for stand-alone VOR/Localizer equipment (i.e. KX-155, SL30).

### 9.1 List of Wiring Diagrams – EFD1000 E5

Figure #	Description
9-1	EFD1000 E5 Main Connections
9-2	ACU Main Power
9-4	VFR Only - No GPS input Configurations
*9-5	ARINC 429 GPS Interface
*9-6	GNAV without ACU ("Tracker" or No Autopilot) (example: GNS430W without ACU)
*9-7	GNAV with ACU (Autopilot) (example: GNS430 with ACU)
*9-10	ARINC 429 GPS with ACU (Analog Nav and/or Autopilot) - Can also be used for NAV1 only, No GPS config (VFR aircraft only)
*9-11	Legacy(RS232) GPS with ACU (Analog Nav and/or Autopilot)
9-12	KLN89/B & KLN94 Interface

Figure #	Description
9-13	KLN-90/A/B Interface
9-14	Apollo GX-50/55/60/65 Interface
9-15	Analog NAV/VLOC Interface
9-15A	Analog Narco and ARC Navigation Radio Interface
9-16	Bendix/King KAP and KFC 100/140/150/200/250 Autopilot Interface
9-17	S-TEC autopilot interface
9-18	Century autopilot interface
9-18A	Century 21/31/41/2000
9-18B	Century IIB/III 1C388/M & 1C388C/MC
9-18C	Century IIB/II 1C388-2/-3
9-18D	Century IV
9-19	Cessna ARC 300B/400B/800B
9-19A	Cessna 300/400/800 IFCS
9-19B	Cessna Navomatic 400/400A
9-19C	Cessna Navomatic 300A
9-19D	Cessna Navomatic 300
9-20	Bendix FCS-810
9-24	Back-Up NAV Indicator (internal converter)
9-25	Back-Up NAV Indicator (OBS Resolver)
9-26	Back-Up NAV/GPS Indicator (OBS Resolver)
9-27	Non-Aspen Equipment Configuration Notes
Appendix E	EA100 Autopilot Attitude Source, Bendix King and Century - See Appendix E

**Table 9-1: E5 Wiring Diagrams**

## 9.2 Optional Interfaces - ACU and ACU2

Figure #	Description	ACU	ACU2
9-28A	Magnetic Heading - Low Speed ARINC 429	X	X
9-28A	Magnetic Heading - High Speed ARINC 429		X
9-28A	Air Data output (ARINC 429) - ACU installations must use RS-232 output from EFD (Fig 9.28) for Air Data output.		X
9-28B	Magnetic Heading -ARINC 407 Synchro		X

**Table 9-2: Optional ACU/ACU2 Interfaces**

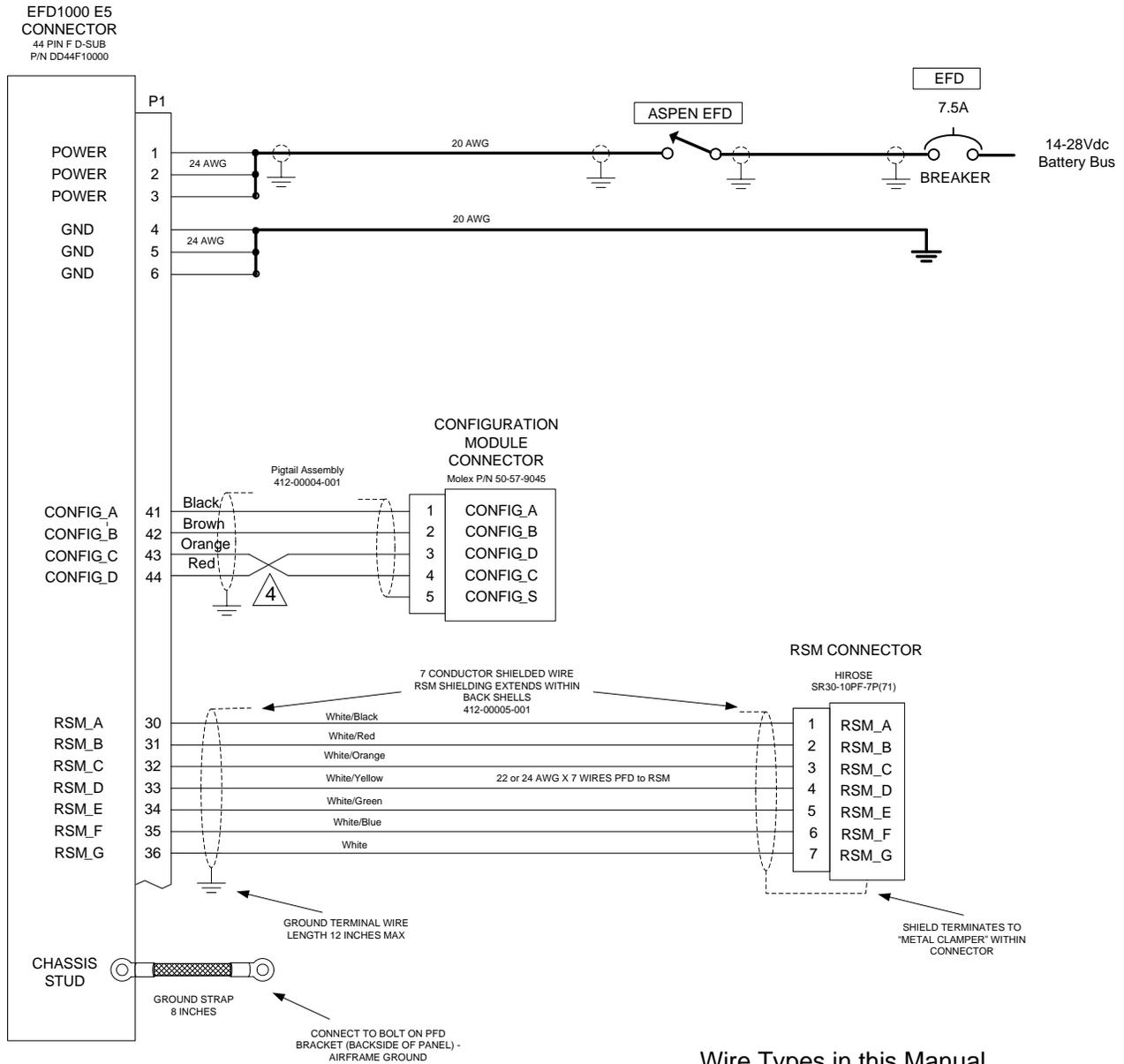

- 1 All wires in this manual are 22 AWG unless otherwise noted.
- 2 Connect ground lugs to airframe ground with as short a conductor as possible.
- 3 Connect to airframe ground with as short a conductor as possible.
- 4 Note wires cross and are not in numerical order

Wire Types in this Manual

- SINGLE UNSHIELDED MIL-W-22759
- SINGLE SHIELDED 22 AWG MIL-W-27500
- ⊗ TWISTED SHIELDED PAIR 22 AWG MIL-W-27500
- ⋯ TINNED COPPER OVERBRAID DABURN P/N 2350-X
- ⊗ HIRF/ LIGHTNING OVER BRAID OR DOUBLE SHIELDED WIRE

Figure 9-1: EFD1000 E5 Main Connections

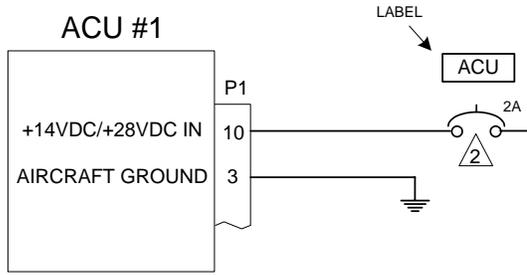

- 1 All wires are 22 AWG unless otherwise noted.
- 2 2 amp circuit breaker MS26574-2 or equivalent. Connect to avionics bus or battery bus if no avionics bus exists.
- 3 ACU Chassis must be connected to airframe ground for proper operation. If ACU case is not grounded by mounting to metal shelf or attachment point then a ground wire from case to airframe ground must be installed.

Figure 9-2: ACU/ACU2 Input Power

Figure 9-3: Reserved

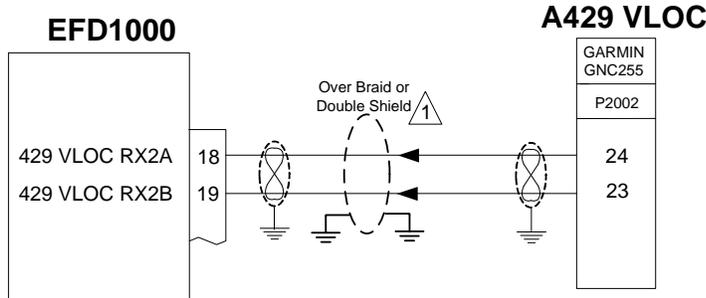

Configuration Matrix (see Section 10)

ID#1	ID#2	Description
NONE	NONE	No GPS1, No VLOC1
I	NONE	No GPS1, VLOC1

The only other configuration with no GPS for VFR Aircraft that is approved is one with an analog NAV – see Figure 9-10

- 1 Over shield or over braid required on this wire bundle to comply with HIRF & Lightning. Extend within back shell. Ground at both ends.

Figure 9-4: VFR Only No GPS input configurations

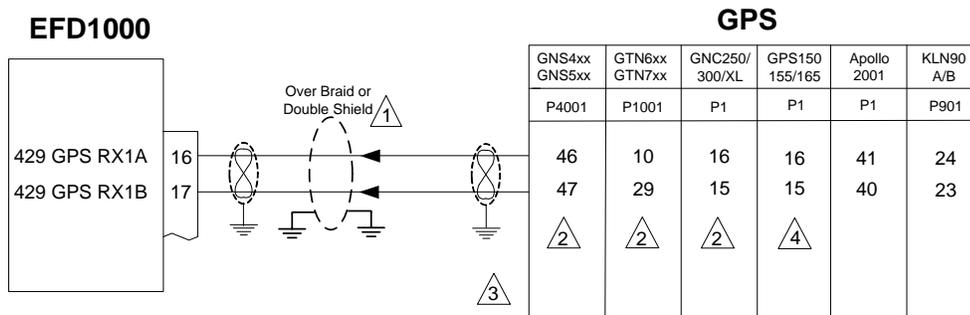

Configuration Matrix (see Section 10)

ID#1	ID#2	Description
C	NONE	GPS1, No GPS2

- 2 See Figure 9-27 for GPS configuration.
- 3 Back-up NAV indicator maybe required for IFR use. Consult manufacturers' installation manual.
- 4 Configure GPS for "King EFS 40/50"
- 5 Refer to manufacturers' documentation to verify the integration data and for information regarding checkout procedures. This drawing, as it pertains to the non-Aspen equipment, is for reference only.

Figure 9-5: ARINC 429 GPS without ACU

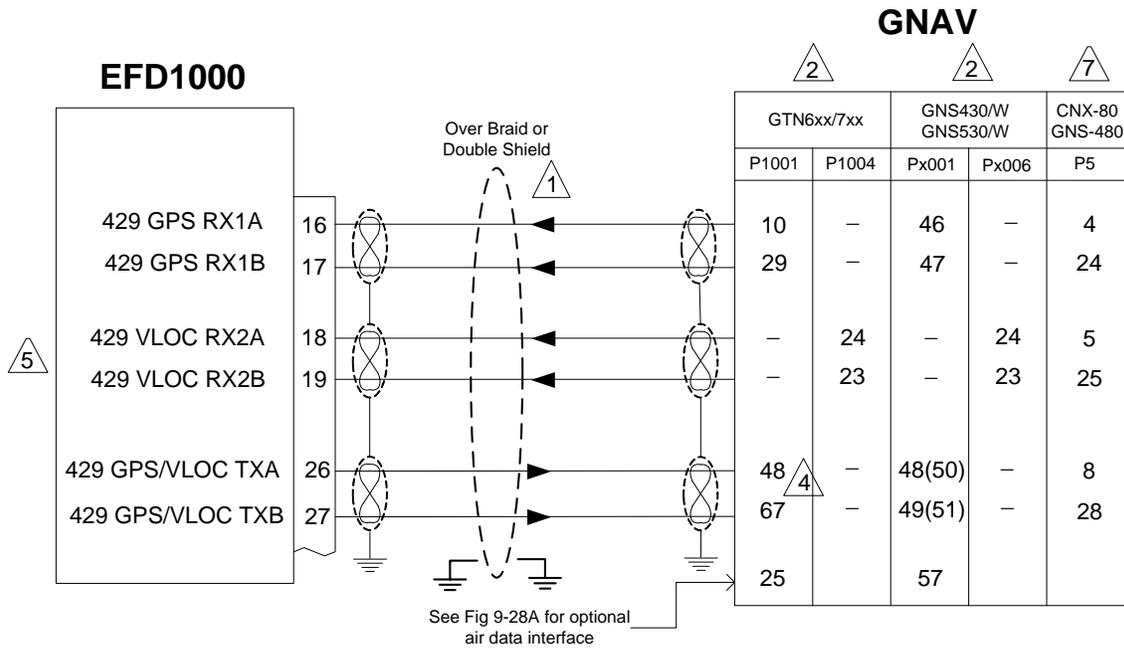

1 Over shield or over braid required on this wire bundle to comply with HIRF & Lightning. Extend within back shell. Ground at both ends.

2 See Figure 9-27 for GNS/GTN configuration.

3 Use pins 48 & 49 or 50 & 51 not both

4 If 429 IN 1 is in use see manufacturers installation instructions and wire to another unused 429 IN Port.

5 GPS-400, GPS-500, GTN625/635/725 use same connections minus the VLOC wiring. PFD pins 18 and 19 are no connect.

6 Pins 4 & 24 may be swapped with pins 5 & 25 if configured accordingly.

7 Requires GNS-480 SW v2.3. See Figure 9-27 for GNS-480 configuration.

8 Refer to manufacturers' documentation to verify the integration data and for information regarding checkout procedures. This drawing, as it pertains to the non-Aspen equipment, is for reference only.

**Configuration Matrix**  
(see Section 10)

ID#1	ID#2	Description
A	NONE	GNS430, No GPS2 Tracker Autopilot
C	NONE	GPS400, No GPS2 Tracker Autopilot

\*GNS530, GNS480, and GTN650/750 use same config as GNS430

\*GPS500 and GTN625/635/725 uses same config as GPS400

**Figure 9-6: GNAV without ACU ("Tracker" or no Autopilot)**

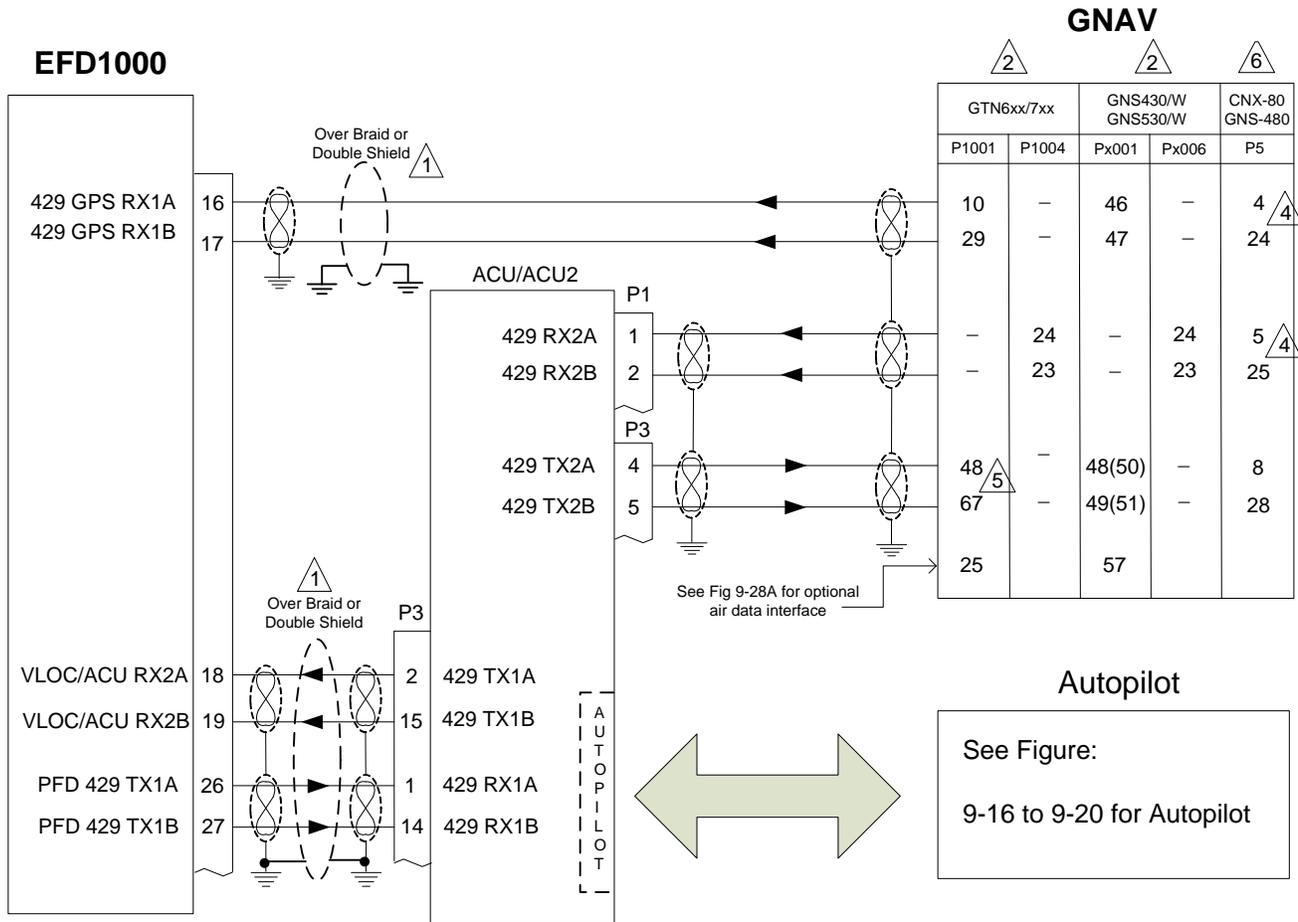

- 1 Over shield or over braid required on this wire bundle to comply with HIRF & Lightning. Extend within back shell. Ground at both ends.
- 2 See Figure 9-27 for GNAV configuration.
- 3 Use pins 48 & 49 or 50 & 51 not both.
- 4 Pins 4 & 24 may be swapped with pins 5 & 25 if configured accordingly.
- 5 If 429 IN 1 is in use see manufacturers installation instructions and wire to another unused 429 IN Port.
- 6 Requires GNS-480 SW v2.3. See Figure 9-27 for GNS-480 configuration.
- 7 Refer to manufacturers' documentation to verify the integration data and for information regarding checkout procedures. This drawing, as it pertains to the non-Aspen equipment, is for reference only.

**Configuration Matrix**  
(see Section 10)

ID#1	ID#2	Description
B	NONE	GNS430 With Autopilot

\*GNS530, GNS480 and GTN650/750 use same config as GNS430

**Figure 9-7: GNAV with ACU (Autopilot)**

**Figure 9-8: Reserved**

**Figure 9-9: Reserved**

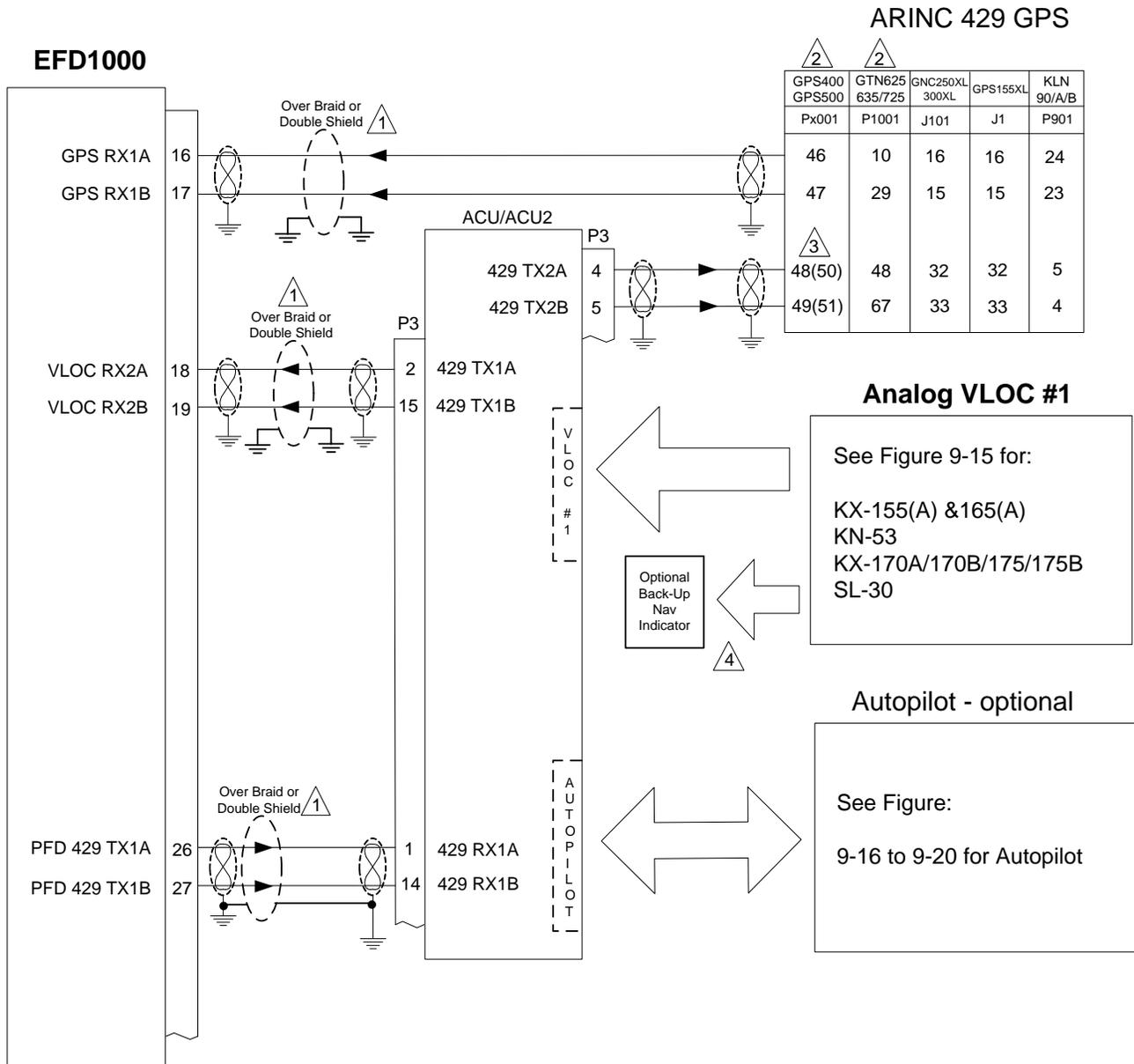
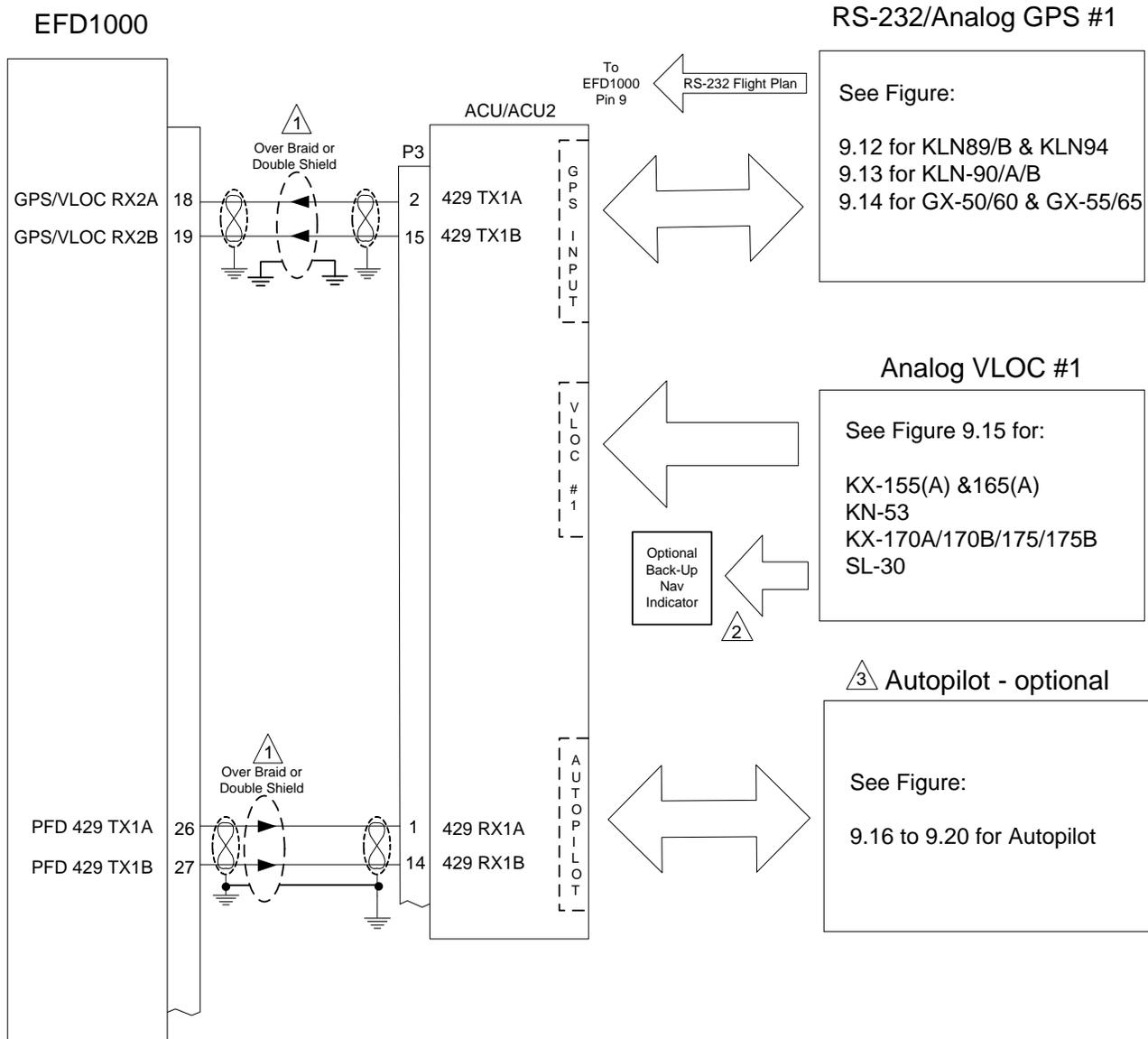

Figure 9-10: ARINC 429 GPS with ACU (Analog Nav and/or Autopilot)



**Configuration Matrix**  
(see Section 10)

ID#1	ID#2	Description
G	NONE	GPS1, No NAV1
H	NONE	GPS1, NAV1

- ⚠️ 1 Over shield or over braid required on this wire bundle to comply with HIRF & Lightning. Extend within back shell. Ground at both ends.
- ⚠️ 2 See Figure 9.24, 9.25, 9.26 for Back-Up NAV recommendations.
- ⚠️ 3 Refer to manufacturers' documentation to verify the integration data and for information regarding checkout procedures. This drawing, as it pertains to the non-Aspen equipment, is for reference only.

**Figure 9-11: RS-232 GPS with ACU (Analog Nav and/or Autopilot)**

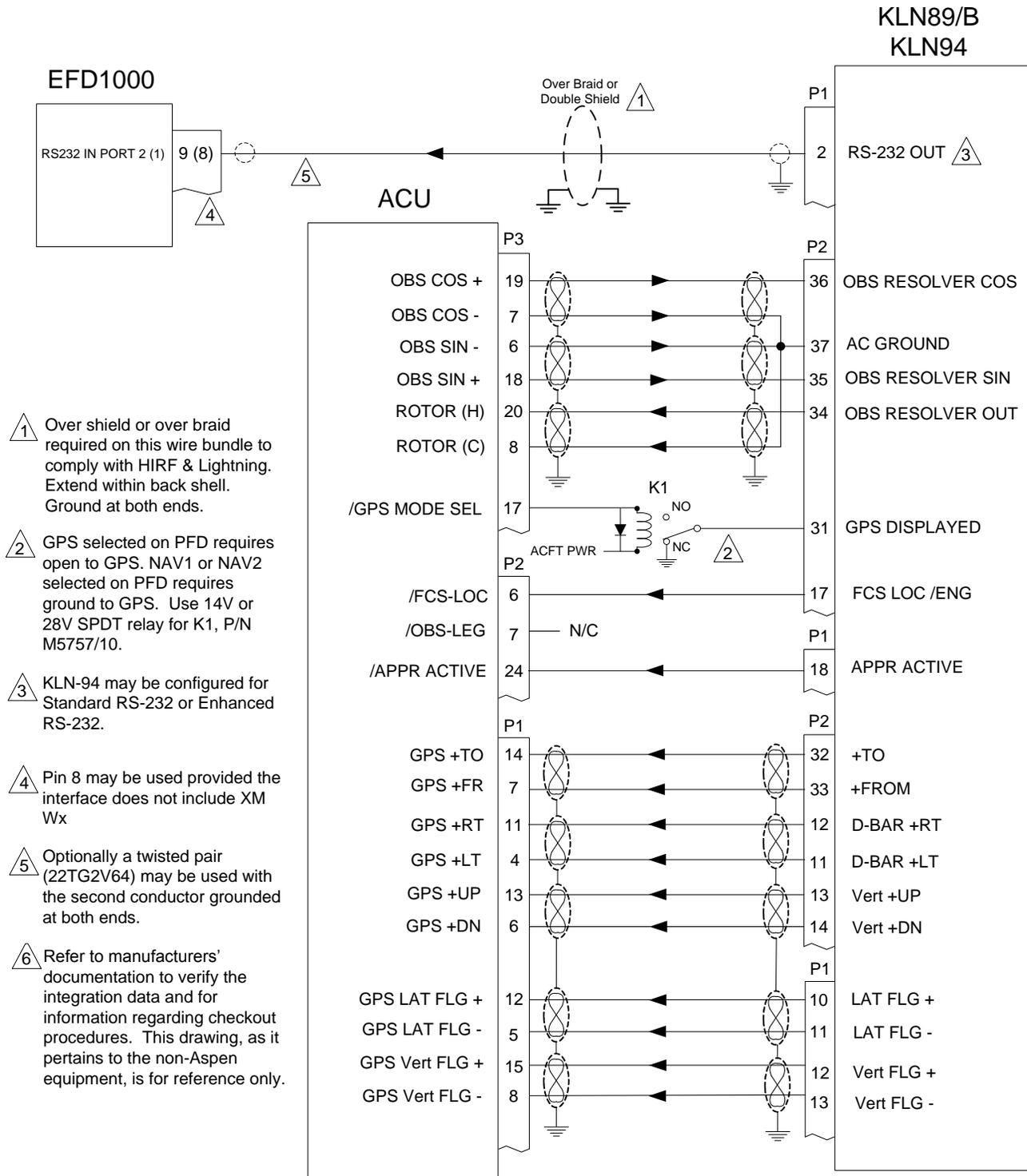

Figure 9-12: KLN89B & KLN94 RS-232 and Analog to ACU Interface

ARINC 429 is the preferred connection, see Figure 9-10  
RS232 does not support GPSS

KLN-90/A/B

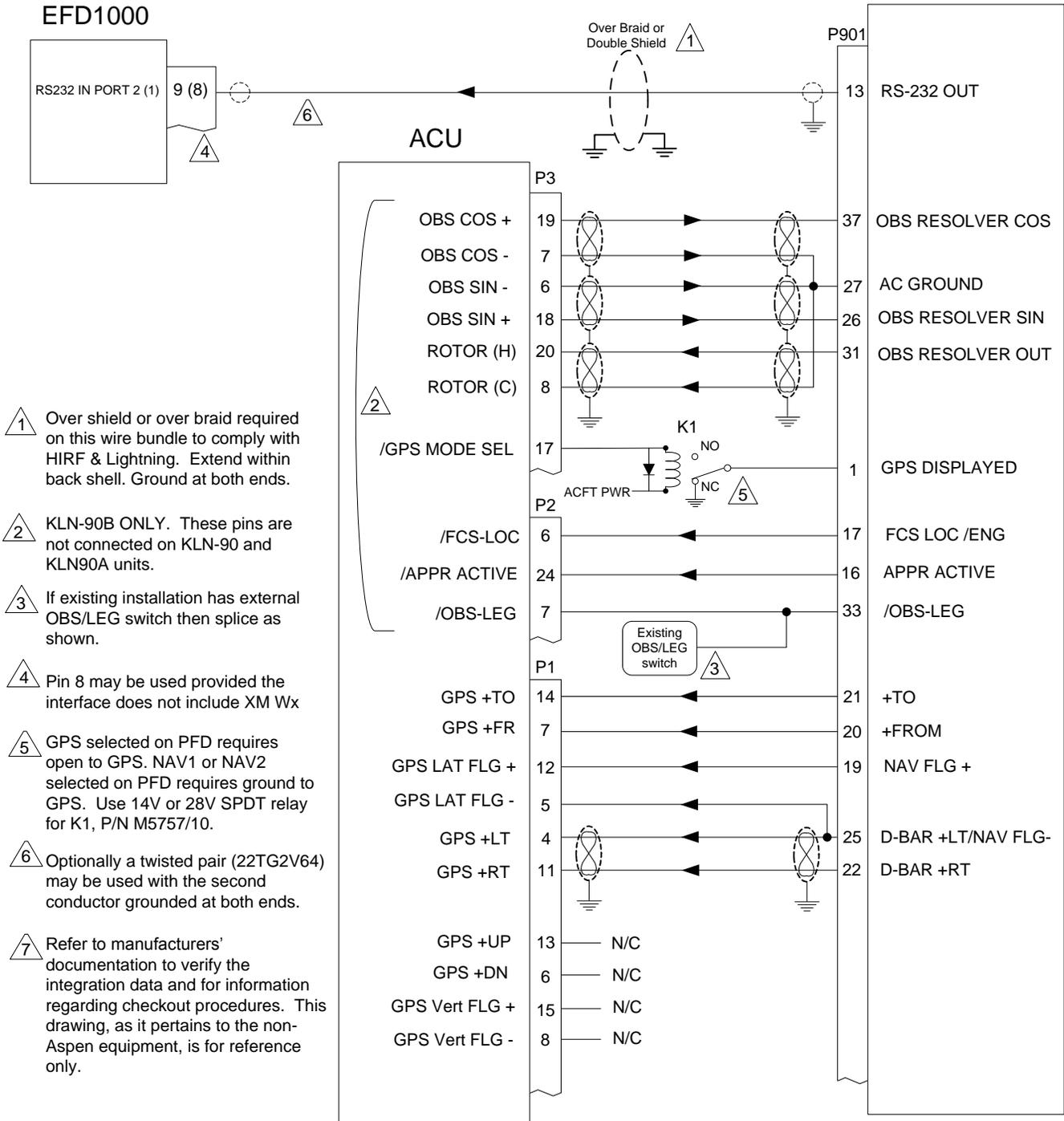
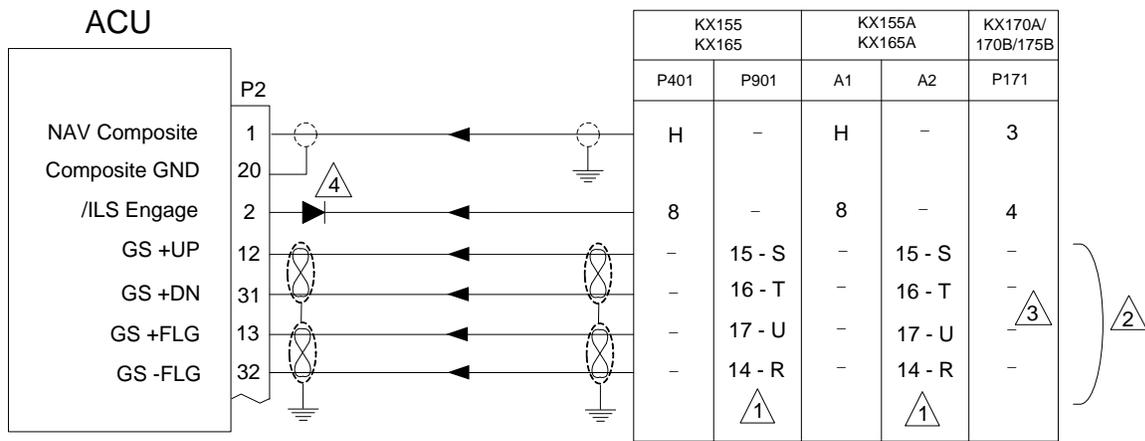

Figure 9-13: KLN-90/A/B RS-232 and Analog to ACU Interface





1 KX155/165 Nav units have dual GS outputs. Use "Numbered" or Lettered pins, not both. Use unused pins independent from those driving a backup NAV indicator if possible. Otherwise parallel as close to NAV receiver as possible (see Figure 9-24 & 9-25)

2 Glideslope interface is for units with GS option.

3 See manufacturers' documentation for KN-70/73/75 Glideslope connections.

4 Diode required when paralleling ILS Energize wire with backup NAV indicator. See Figure 9-24. Use 1N4005.

5 Refer to manufacturers' documentation to verify the integration data and for information regarding checkout procedures. This drawing, as it pertains to the non-Aspen equipment, is for reference only.

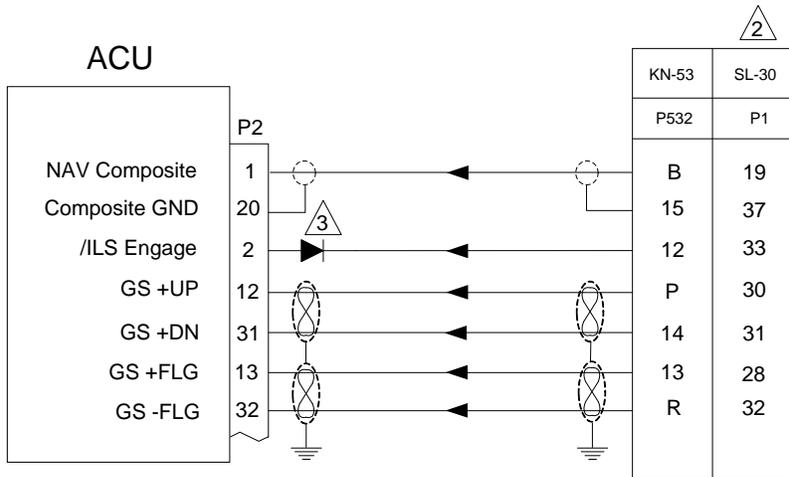

1 If paralleling GS signals with backup NAV indicator then splice wires as close to NAV receiver as possible. Do not parallel at back of NAV indicator (see Figures 9-24 & 9-25)

2 See Figure 9-27 for SL-30 configuration.

3 Diode required when paralleling ILS Energize wire with backup NAV indicator. See Figure 9-24. Use 1N4005.

4 Refer to manufacturers' documentation to verify the integration data and for information regarding checkout procedures. This drawing, as it pertains to the non-Aspen equipment, is for reference only.

Figure 9-15: Analog NAV Interface

## NARCO and Cessna ARC Radio Interfaces

Note:

The composite output from these radios use a DC offset voltage. A capacitor is required as shown below.

Note:

The composite output with some of these radios is 180 degrees out of phase so the "Composite Phase (VOR1,2)" must be configured for 180 in the EFD1000 configuration.

Note:

The Glide Slope output from some Narco radios can only drive one load and therefore it may not be possible to parallel these to a mechanical NAV indicator as well as the ACU. This also may apply to radios with integrated CDI/VDI (i.e., NAV 122) as they were not designed to drive an external load. ACU2 installations can use the high impedance MK12D GS Flag input which may allow paralleling the indicator.

Note:

If it is not possible to connect the Glide Slope output to the ACU the composite and ILS Energize can still be connected so that it can be used as a CDI on the HSI and as a bearing pointer.

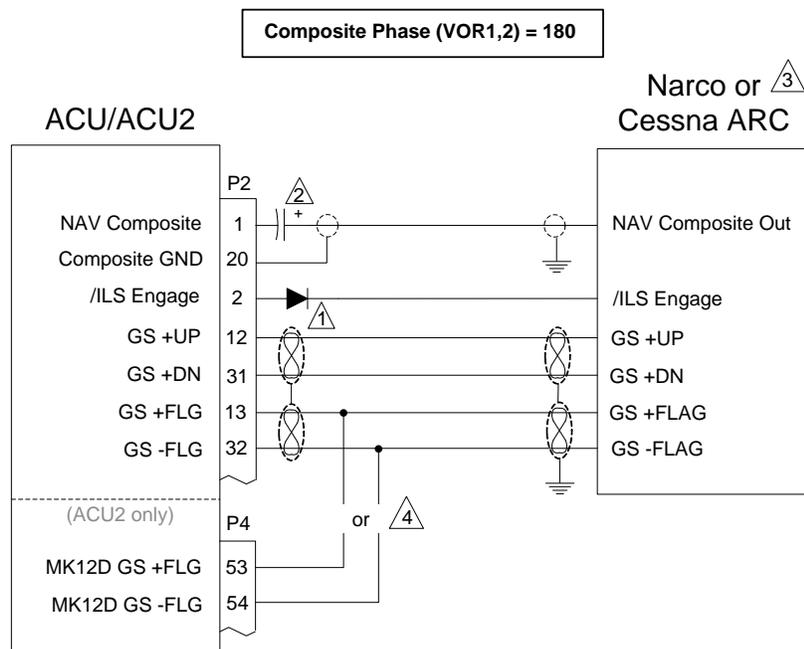

1 Diode required when paralleling ILS Energize wire with backup NAV indicator. Use IN4005.

2 Capacitor is electrolytic type from 10uf to 47uf with a minimum 25V rating. Paralleling of composite signal to backup NAV indicator is made between capacitor and NAV radio.

3 Includes other manufacturers Narco and ARC replacement radios

4 Do Not connect GS Flag to both P2 and P4 connectors. Use only one input. For ACU2 installations it is recommended to use the P4 input on all Narco radios.

5 Refer to manufacturers' documentation to verify the integration data and for information regarding checkout procedures. This drawing, as it pertains to the non-Aspen equipment, is for reference only.

Figure 9-15A: Narco and Cessna ARC Navigation Radios

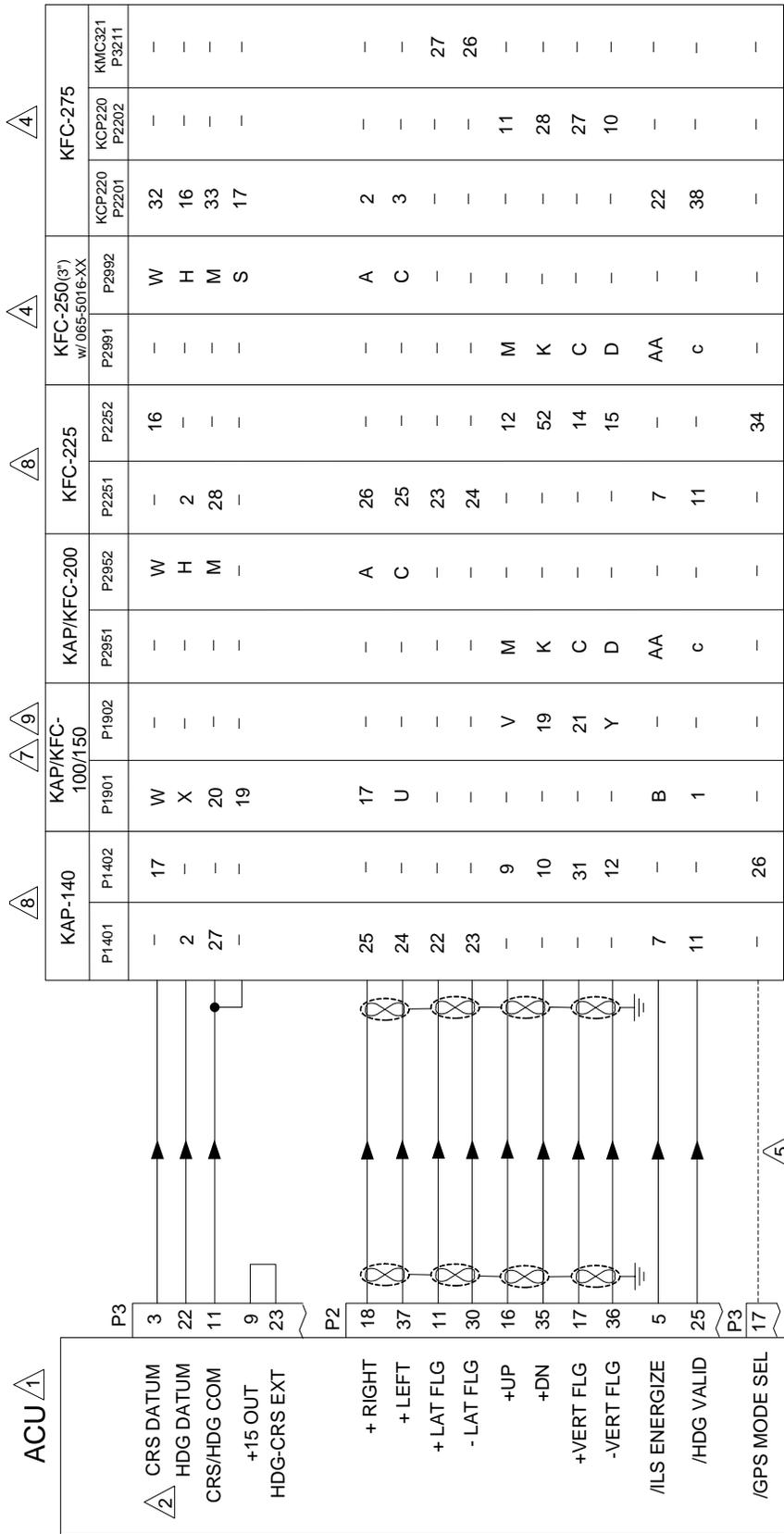
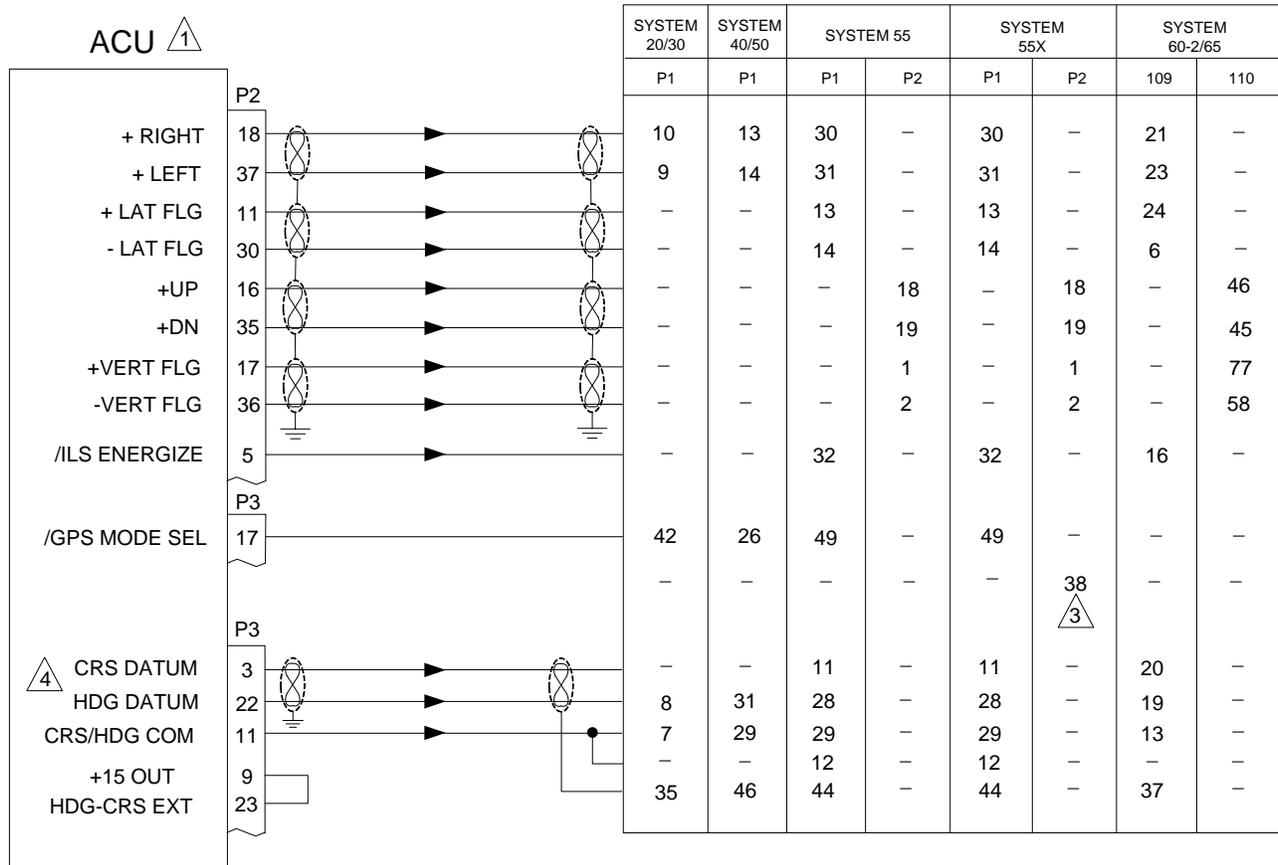

Figure 9-16: KI525A Emulation (Bendix/King autopilot to ACU)

- 1 Autopilot can only be connected to ACU #1 in a dual ACU configuration.
- 2 If the existing DG/HSI is to remain in the aircraft do not parallel HDG/CRS Datum with ACU. Cap and Stow at DG/HSI.
- 3 This note is not used
- 4 KFC-250/275 HDG & CRS Datum for 3" Instruments (KCS-55A) only.
- 5 GPS Mode Sel. If connected on a WAAS capable GPS it will not allow the autopilot's vertical mode to couple. It can be connected on all other GPS types.
- 6 Installations with a Yaw system and a KRG331/332 rate gyro and are removing the KG102A may need to install a peanut inverter if the KRG331/332 got its 26VAC from the KG102A.
- 7 If removing a KG-107 DG the KAP/KFC 19X computer will need to have the Top Board Adapter Module changed so that CJ601 "DG/HSI Sel Strap" is correct. Otherwise the PFD HDG Bug will control HDG and NAV modes, no CRS pointer input.
- 8 If removing a DG reprogram the KAP140 or KFC225 autopilot computer for "HSI".
- 9 ACU outputs not compatible with KFC19X-16 computers as they have specific outputs for EFIS40.
- 10 Refer to autopilot manufacturers' documentation for autopilot-side integration information (including autopilot STC compliance data) and for autopilot and flight director checkout procedures. This drawing, as it pertains to the non-Aspen equipment, is for reference only.

Configuration Matrix  
(see Section 10)

**ACU HSI TYPE = 0**



1 Autopilot can only be connected to ACU #1 in a dual ACU configuration.

2 This note is not used

3 P2-38 is GPSS SELECT which is grounded when there is an A429 GPSS direct connection between GPS and 55X. When using the EFD1000 GPSS only, this pin is left open.

4 CRS/HDG Datum is wired to simulate a KI-525A HSI. If existing HSI is other than KI-525A then autopilot needs to be modified to accept KI525A inputs.

5 If existing installation used a DG then a DG Select jumper may need to be removed. Refer to S-TEC reference material.

6 If the existing DG/HSI is to remain in the aircraft do not parallel HDG/CRS Datum with ACU. Cap and Stow at DG/HSI.

7 Refer to autopilot manufacturers' documentation for autopilot-side integration information (including autopilot STC compliance data) and for autopilot and flight director checkout procedures. This drawing, as it pertains to the non-Aspen equipment, is for reference only.

Configuration Matrix  
(see Section 10)

**ACU HSI TYPE = 0**

Figure 9-17: S-TEC Autopilot to ACU Interface

\*Must also make HDG/CRS connections per Figure 9-18A, 9-18B, 9-18C, or 9-18D

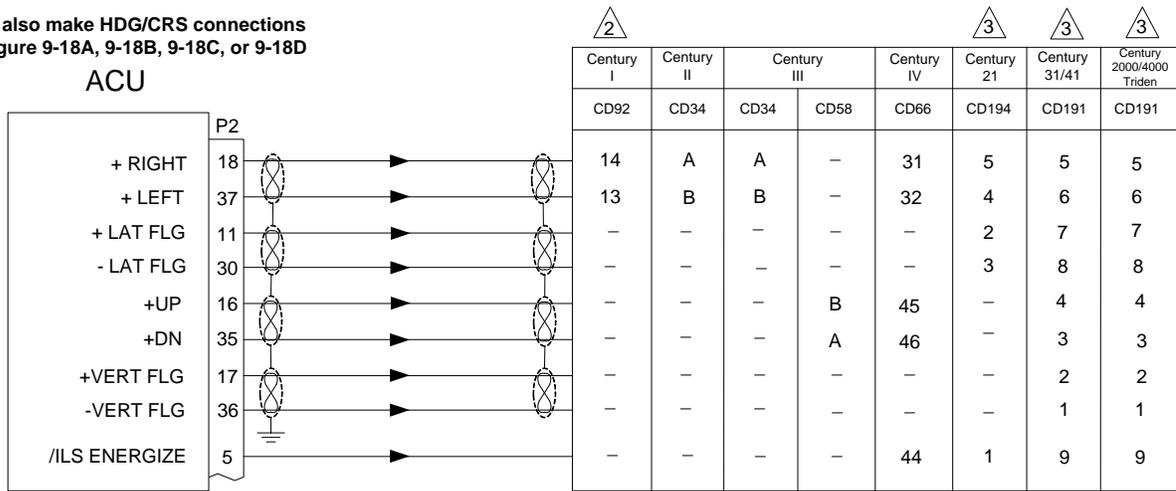

- 1 Autopilot can only be connected to ACU #1 in a dual ACU configuration.
- 2 Century I autopilot is L/R only.
- 3 This note is not used
- 4 Shield wires per existing autopilot specification single shielded or twisted shielded pair.
- 5 Refer to autopilot manufacturers' documentation for autopilot-side integration information (including autopilot STC compliance data) and for autopilot and flight director checkout procedures. This drawing, as it pertains to the non-Aspen equipment, is for reference only.

Figure 9-18: Century Autopilot to ACU Interface (minus HDG/CRS Datum)

**CAUTION**

Damage to the ACU or autopilot computer could occur if wiring is not exactly as shown. Before connecting the HDG and CRS Datum wiring to the autopilot computer, the HDG and CRS Datum voltages should be checked per below. Also, if a DG was previously installed verify that the DG Select Strap - C21 (CD194-13), or C31 (CD200-32), or C41 (CD185-17), or C2000 (CD220-42), or C4000 (CD279-12) is removed (not grounded) as it shorts the HDG and CRS inputs together.

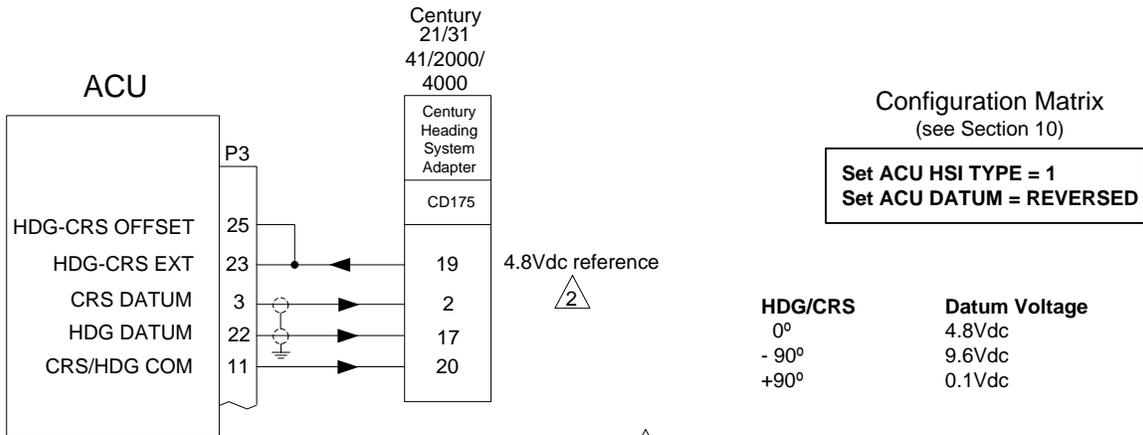

When replacing a DC version NSD-360

- 1 If the existing DG/HSI is to remain in the aircraft do not parallel HDG/CRS Datum with ACU. Cap and Stow at DG/HSI or use switch.
- 2 Interface uses 4.8Vdc reference from CD175 pin 19 ARINC Ref Low. 9.6Vdc reference not used.
- 3 Century 21/31/41/2000/4000 should be wired per DC Datum drawing above, if they were previously wired AC then the ARINC Select strap needs to be removed. The 31 requires that the 1B929 ARINC Adapter box be removed.
- 4 Refer to autopilot manufacturers' documentation for autopilot-side integration information (including autopilot STC compliance data) and for autopilot and flight director checkout procedures. This drawing, as it pertains to the non-Aspen equipment, is for reference only.

Figure 9-18A: NSD360A Emulation (Century 21/31/41/2000/4000)

**CENTURY 1C388, 1C388M, 1C388C, 1C388MC and No RADIO COUPLER installations**

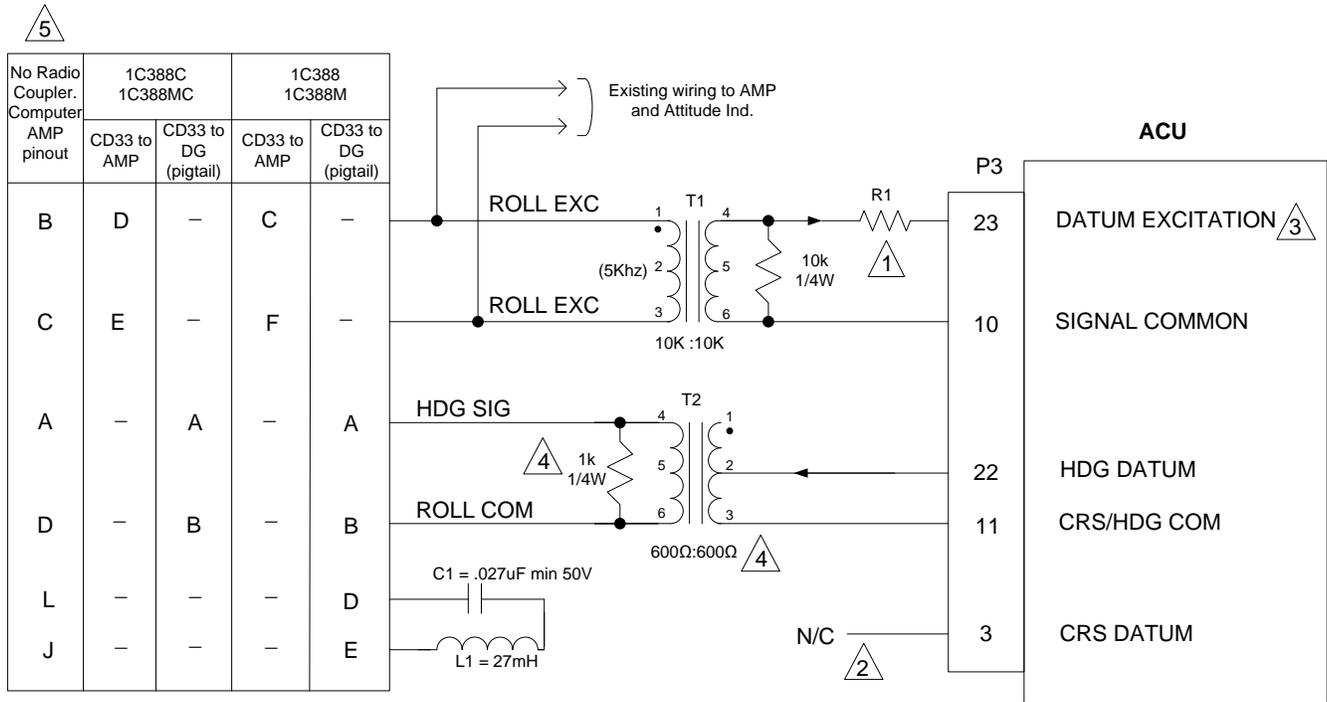

**PARTS:**  
 T1 – Use Triad SP-66 MIL No. TF5S21ZZ.  
 T2 – New Installations: Use Triad SP-67 MIL No. TF5S21ZZ.  
 T2 – Existing Installations: May continue to use a SP-66 unless performance was unacceptable, then use SP-67.  
 L1 - JW Miller PN: 8250-273-RC.  
 C1 – .027uf capacitor M39014/011463.

**1C388 & 1C388M**

**Set ACU HSI TYPE = 1**  
**Set ACU DATUM = REVERSED**

**1C388C & 1C388MC**

**Set ACU HSI TYPE = 3**  
**Set ACU DATUM = REVERSED**

**T2 Transformer** 4

Some earlier designs of radio couplers have an internal transformer and a lower input impedance. A lower impedance T2 (SP-67) may be required to achieve the 45 degree NAV intercept angle. On all new installations it is recommended to use a SP-67 for T2. Existing installations may continue to use the SP-66 provided system performance is acceptable. A SP-67 may be used provided the 10K parallel resistor is changed to 1k and the value of R1 is adjusted accordingly.

- 1 The value of R1 can range from 0K to 900K. A value for R1 should be selected that sets the NAV intercept angle at 45 degrees. Consult autopilot manufacturers' reference documents for post install checkout procedures.
- 2 This radio coupler does not have CRS Datum interface. You must upgrade to 1C-388-2 or -3 coupler to gain this feature.
- 3 Using Pin 21 is acceptable on previous installations.
- 4 If using the SP-67 use a 1K parallel resistor. If using the SP-66 use a 10K parallel resistor.

- 5 If the installation does not have a radio coupler the ACU may be connected directly to the computer amp as shown. The EFD1000 will operate the autopilot by HDG Bug and GPSS (if compatible GPS).
- 6 Refer to autopilot manufacturers' documentation for autopilot-side integration information (including autopilot STC compliance data) and for autopilot and flight director checkout procedures. This drawing, as it pertains to the non-Aspen equipment, is for reference only.

**Figure 9-18B: NSD360A Emulation Century 1C388/M, 1C388C/MC Radio Couplers**

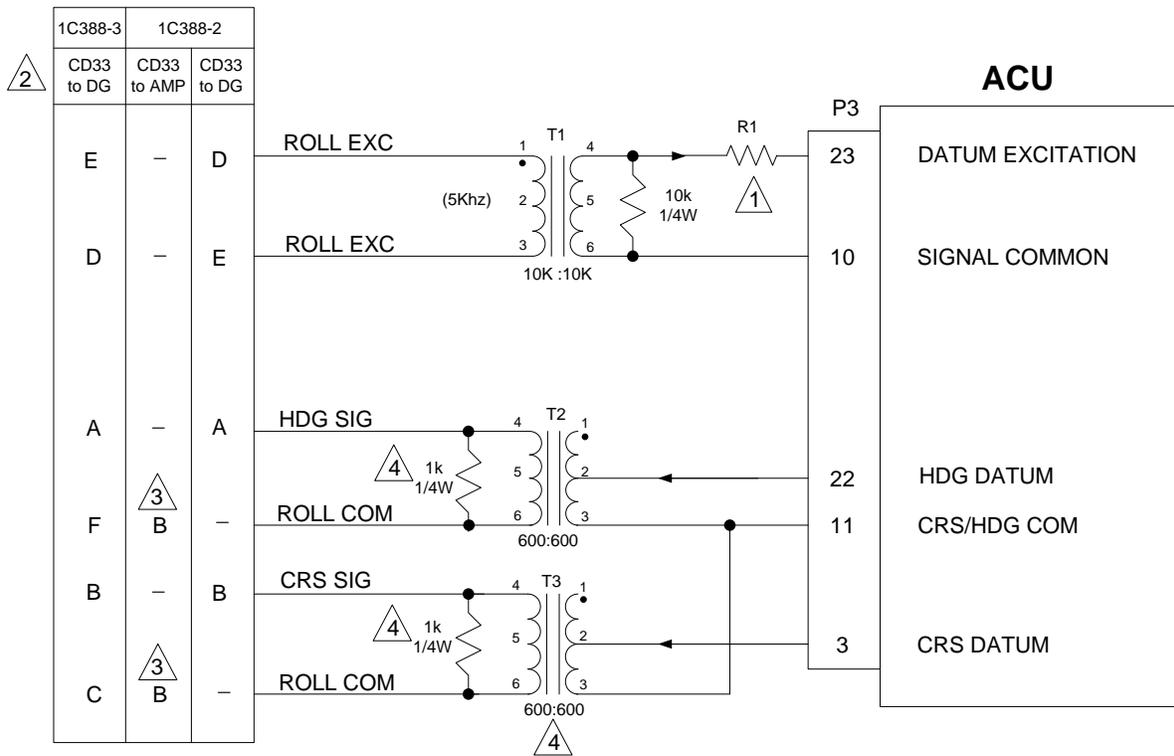

**PARTS:**  
 T1 – Use Triad SP-66 MIL No. TF5S21ZZ.  
 T2/T3 – New Installations: Use Triad SP-67 MIL No. TF5S21ZZTY.  
 T2/T3 – Existing Installations: May continue to use a SP-66 unless performance was unacceptable, then use SP-67.

**1C388-2**

**Set ACU HSI TYPE = 1**  
**Set ACU DATUM = REVERSED**

**1C388-3**

**Set ACU HSI TYPE = 3**  
**Set ACU DATUM = REVERSED**

**T2/T3 Transformer** ④

Some earlier designs of radio couplers have an internal transformer and a lower input impedance. A lower impedance T2 and T3 (SP-67) may be required to achieve the 45 degree NAV intercept angle. On all new installations it is recommended to use a SP-67 for T2/T3. Existing installations may continue to use the SP-66 provided system performance is acceptable. A SP-67 may be used provided the 10K parallel resistor is changed to 1k and the value of R1 is adjusted accordingly.

- ① The value of R1 typically ranges from 0K to 50K. A value for R1 should be selected that sets the NAV intercept angle at 45 degrees. Consult autopilot manufacturers' reference documents for post install checkout procedures.
- ② CD33 to DG is the pigtail on the back of the radio coupler. CD33 to AMP is one of the hard mounted connectors on the radio coupler.
- ③ Pin B is the low side of both T2 and T3. Parallel with any existing wires on this pin B.

- ④ If using the SP-67 use a 1K parallel resistor. If using the SP-66 use a 10K parallel resistor.
- ⑤ Refer to autopilot manufacturers' documentation for autopilot-side integration information (including autopilot STC compliance data) and for autopilot and flight director checkout procedures. This drawing, as it pertains to the non-Aspen equipment, is for reference only.

**Figure 9-18C: NSD360A Emulation Century 1C388-2/-3 Radio Couplers**

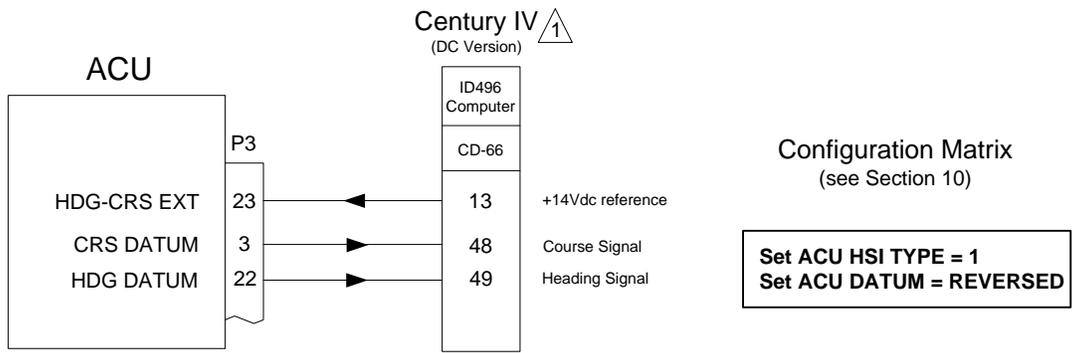

<sup>1</sup> In order to use this interconnect the ID496 Computer Amplifier must have Roll Module 1C695-1 installed to be NSD-360 compatible.

<sup>2</sup> Refer to autopilot manufacturers' documentation for autopilot-side integration information (including autopilot STC compliance data) and for autopilot and flight director checkout procedures. This drawing, as it pertains to the non-Aspen equipment, is for reference only.

**Figure 9-18D: NSD-360A Emulation Century IV (DC version)**

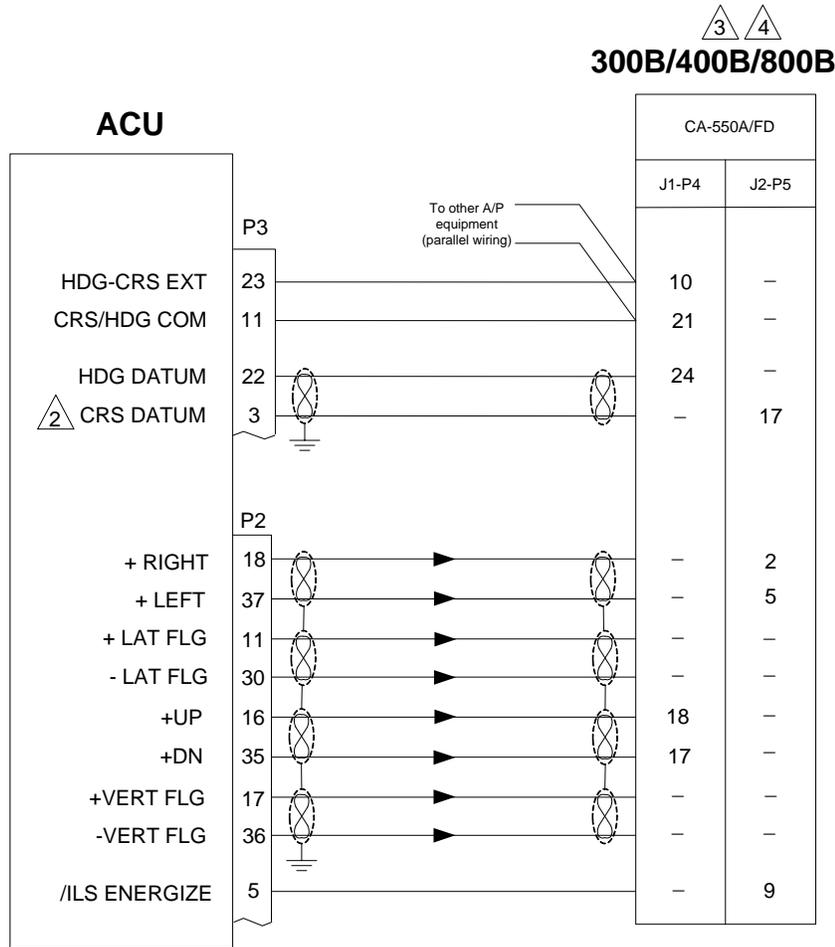

1 Autopilot can only be connected to ACU #1 in a dual ACU configuration.

2 Existing DG installations must make CRS Datum connection as shown to gain full HSI features. Remove Jumper from J2-17 to J1-21 if installed.

3 This note is not used

4 Note – autopilot connections are shown at CA-550A/FD computer but may route through the S-550A Mode selector or A/P Accessory Unit. Wire as shown or ACU may be connected to these units provided NAV1 and NAV2 inputs are jumpered together.

6 Refer to autopilot manufacturers' documentation for autopilot-side integration information (including autopilot STC compliance data) and for autopilot and flight director checkout procedures. This drawing, as it pertains to the non-Aspen equipment, is for reference only.

5 CA-550/FD J1-24 and J2-17 may have been previously connected to ground if they were unused. These prior connections must be removed.

Configuration Matrix  
(see Section 10)

Set ACU HSI TYPE = 1

Figure 9–19: Cessna ARC 300B/400B/800B Autopilot to ACU Interface

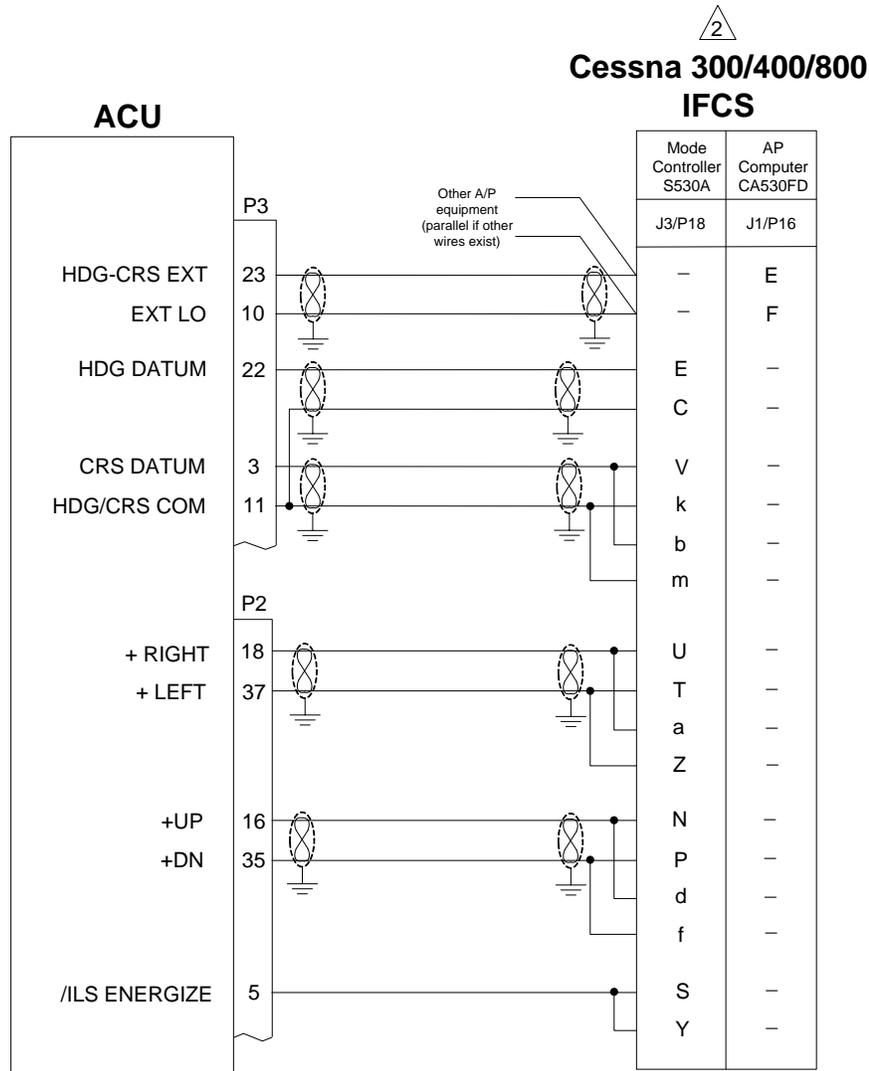

1 Autopilot can only be connected to ACU #1 in a dual ACU configuration.

2 This note is not used

3 CRS Datum, LT/RT, UP/DN, and ILS Energize are paralleled to both the Nav1 and Nav2 inputs on the S530A. This is so that the EFD1000 will drive the autopilot no matter the position of the Nav1/2 selector switch.

4 Refer to autopilot manufacturers' documentation for autopilot-side integration information (including autopilot STC compliance data) and for autopilot and flight director checkout procedures. This drawing, as it pertains to the non-Aspen equipment, is for reference only.

Configuration Matrix  
(see Section 10)

Set ACU HSI TYPE = 1  
Set ACU DATUM = REVERSED

Figure 9-19A: Cessna Navomatic 300/400/800 IFCS to ACU Interface

This interface drawing pertains to a 400 or 400A system with the following Mode Controller and AP Computer combinations:

- ③ C-420A and a CA-520/B
- C-520A/B and a CA-520/B
- C-520A/B and a CA-530A
- C-530A and a CA-530A

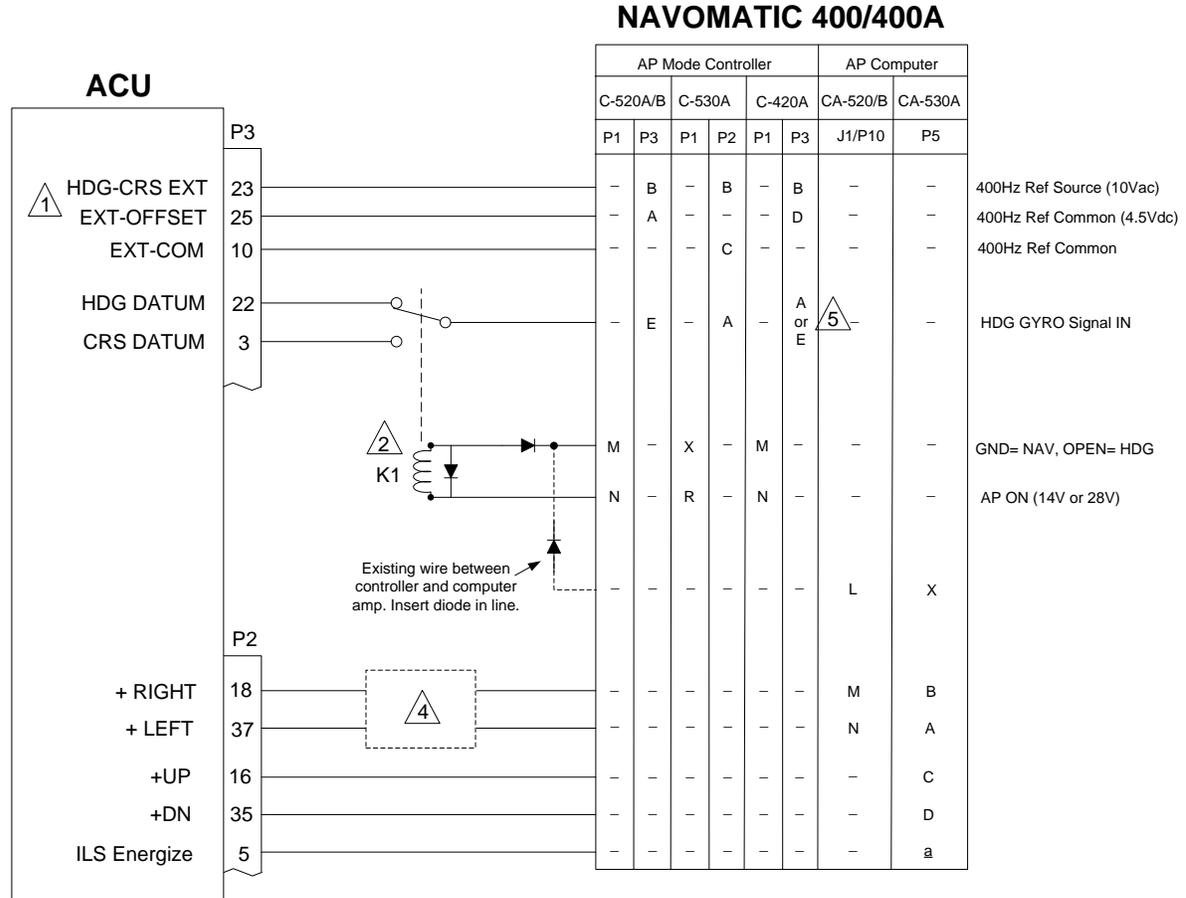

① Verify 10Vac goes to ACU P3-23 and 4.5Vdc goes to ACU P3-25 before connecting the ACU. Sometimes the 10Vac and 4.5Vdc signals are reversed at the mode controller.

② The relay allows the HDG Bug to be used in heading mode and the CRS Pointer to be used in NAV/APPR modes. Optionally the relay may be omitted and ACU P3-22 wired directly to HDG GYRO Signal IN of the mode controller (HDG Bug will be used in HDG and NAV modes). K1 must be rated for 14V or 28V depending on autopilot operating voltage, P/N M5757/10. Diodes are 1N4005.

③ If the mode controller has a integrated HDG knob then it must be modified to work with an external DG.

④ The R/L output is no different than any previous HSI/NAV interface and may need to be run through a Backcourse relay circuit in the Cessna audio control panel or other existing BC relay box.

⑤ NOTE – The C-420A controller could be internally wired in several ways. The HDG IN can be pin A or pin E. Use a ohm meter to check which pin is internally jumpered to C-420A J3 pin D (either A or E) and use the opposite pin for the connection to K1 wiper.

⑥ Refer to autopilot manufacturers' documentation for autopilot-side integration information (including autopilot STC compliance data) and for autopilot and flight director checkout procedures. This drawing, as it pertains to the non-Aspen equipment, is for reference only.

**Configuration Matrix**  
(see Section 10)

Set ACU HSI TYPE = 1  
Set ACU DATUM = REVERSED

**Figure 9-19B: NAVOMATIC 400/400A Autopilot to ACU Interface**

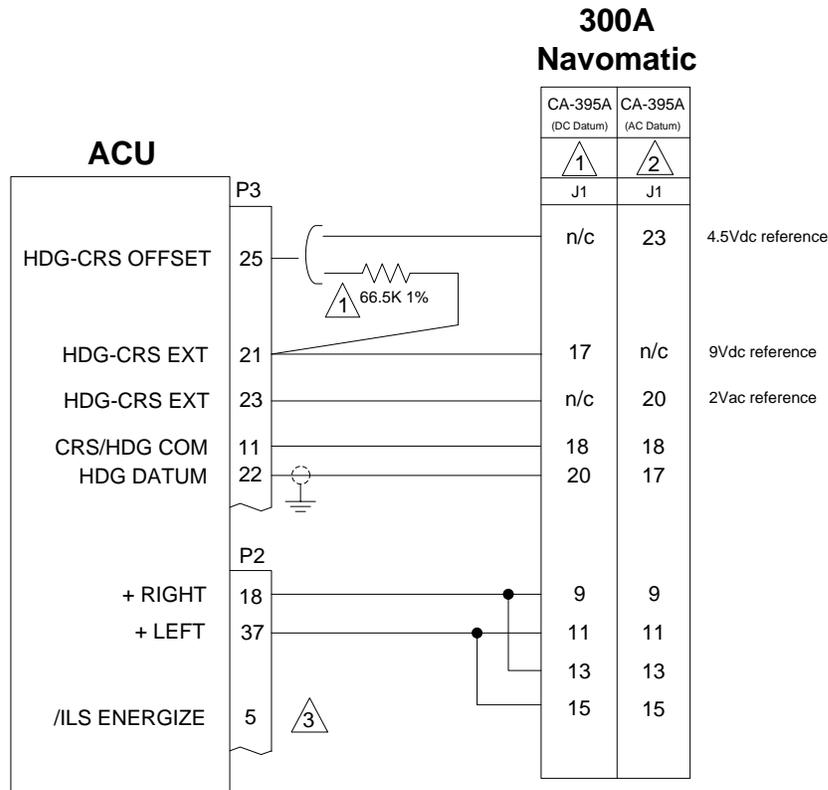

**1 When replacing IG-832C, DC version HSI**

ARC computer p/n 42660-2x0x only. (A3) Heading Demodulator Assembly p/n 43368-0001

Connect 66.5K 1% 1/4W resistor from ACU P3 – 21 to pin 25 with 21 also connected to CA-395 pin 17. Output is as follows:

HDG BUG	DATUM VOLTAGE
-90°	0.5 Vdc
0°	4.5Vdc
+90°	8.5Vdc

Configuration Matrix  
(see Section 10)

1

**Set ACU HSI TYPE = 1**

**2 When replacing G-502A or 504A, AC version DG**

ARC computer p/n 42660-12XX  
Do not use Resistor. Connect ACU P3-25 to CA-395 pin 23.  
Output as follows:

HDG BUG	DATUM VOLTAGE
-90°	2.0 Vac
0°	0 Vac
+90°	2.0 Vac

The ac voltages will ride on a 4.5Vdc offset voltage

2

**Set ACU HSI TYPE = 1**  
**Set ACU DATUM = REVERSED**

**3** ILS Energize out may be used to operate a BC relay in the Cessna Audio Control panel or external BC relay as needed.

**4** Refer to autopilot manufacturers' documentation for autopilot-side integration information (including autopilot STC compliance data) and for autopilot and flight director checkout procedures. This drawing, as it pertains to the non-Aspen equipment, is for reference only.

**Figure 9–19C: Cessna ARC 300A AC & DC version to ACU Interface**

### 300 Navomatic

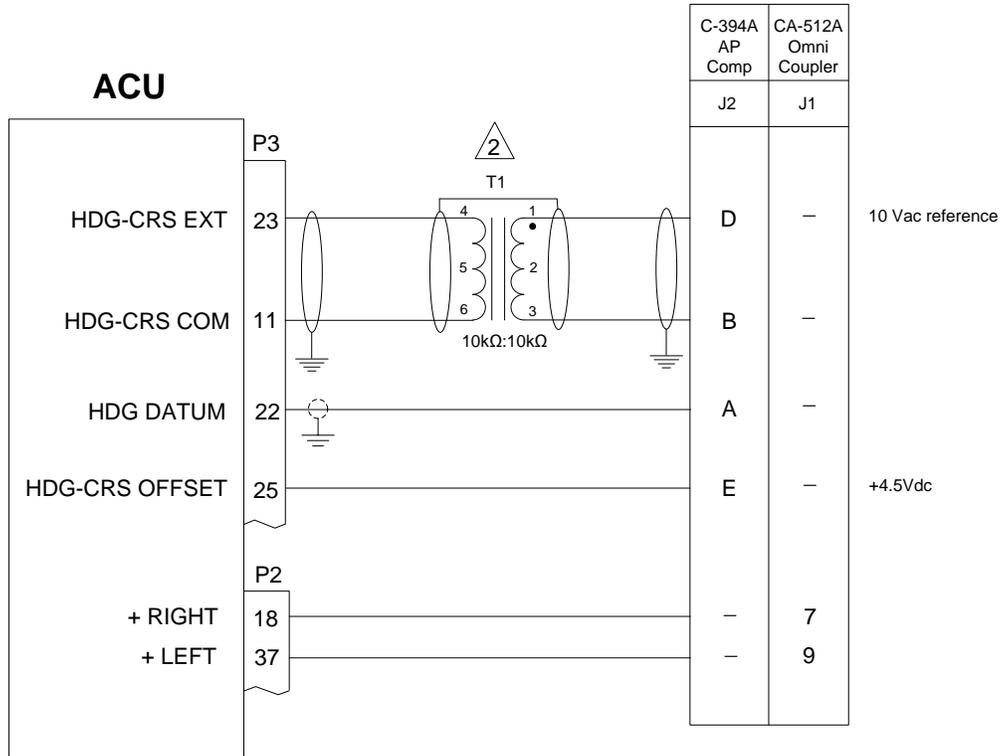

- 1 Autopilot can only be connected to ACU #1 in a dual ACU configuration.
- 2 For T1 use a Triad SP-66 MIL No TF5S21ZZ to isolate the 400hz common of the autopilot computer.
- 3 Refer to autopilot manufacturers' documentation for autopilot-side integration information (including autopilot STC compliance data) and for autopilot and flight director checkout procedures. This drawing, as it pertains to the non-Aspen equipment, is for reference only.

#### Configuration Matrix (see Section 10)

**Set ACU HSI TYPE = 1**

**Figure 9-19D: Cessna 300 Navomatic to ACU Interface**

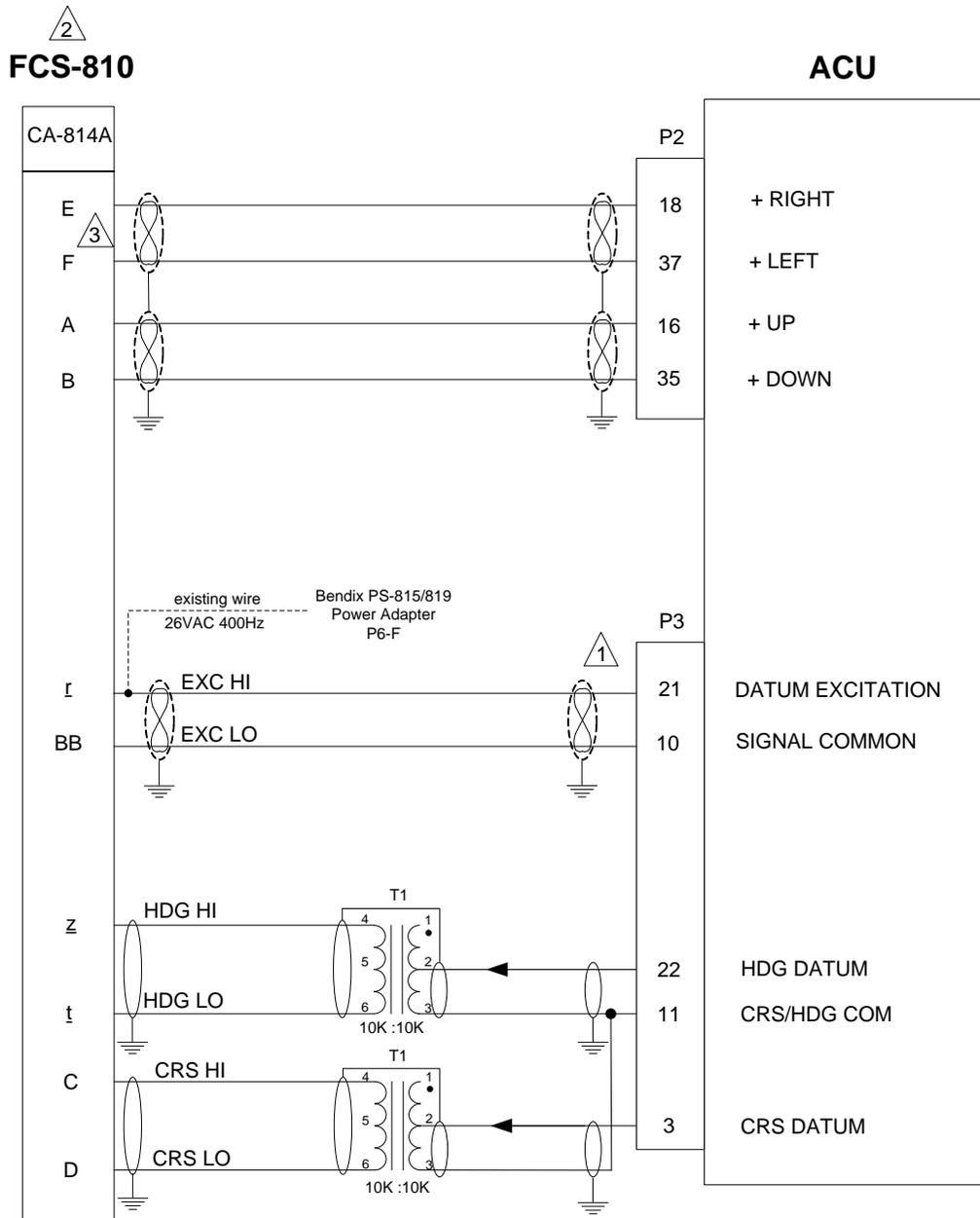

T1 – Use Triad SP-66 MIL No. TF5S21ZZ or equivalent

1 A resistor may be inserted in series with the 26V Exc Hi line connected to ACU P3-21 if lower HDG/CRS gain is required.

2 Flight Director interface not supported at this time.

3 Some CA-814A have the L/R output reversed. Perform ground test to determine if E&F must be reversed.

4 Refer to autopilot manufacturers' documentation for autopilot-side integration information (including autopilot STC compliance data) and for autopilot and flight director checkout procedures. This drawing, as it pertains to the non-Aspen equipment, is for reference only.

Configuration Matrix  
(see Section 10)

Set ACU HSI TYPE = 3  
Set ACU DATUM = NORMAL

Figure 9-20: Bendix FCS-810 Autopilot to ACU

Figure 9-21: Reserved  
 Figure 9-22: Reserved  
 Figure 9-23: Reserved

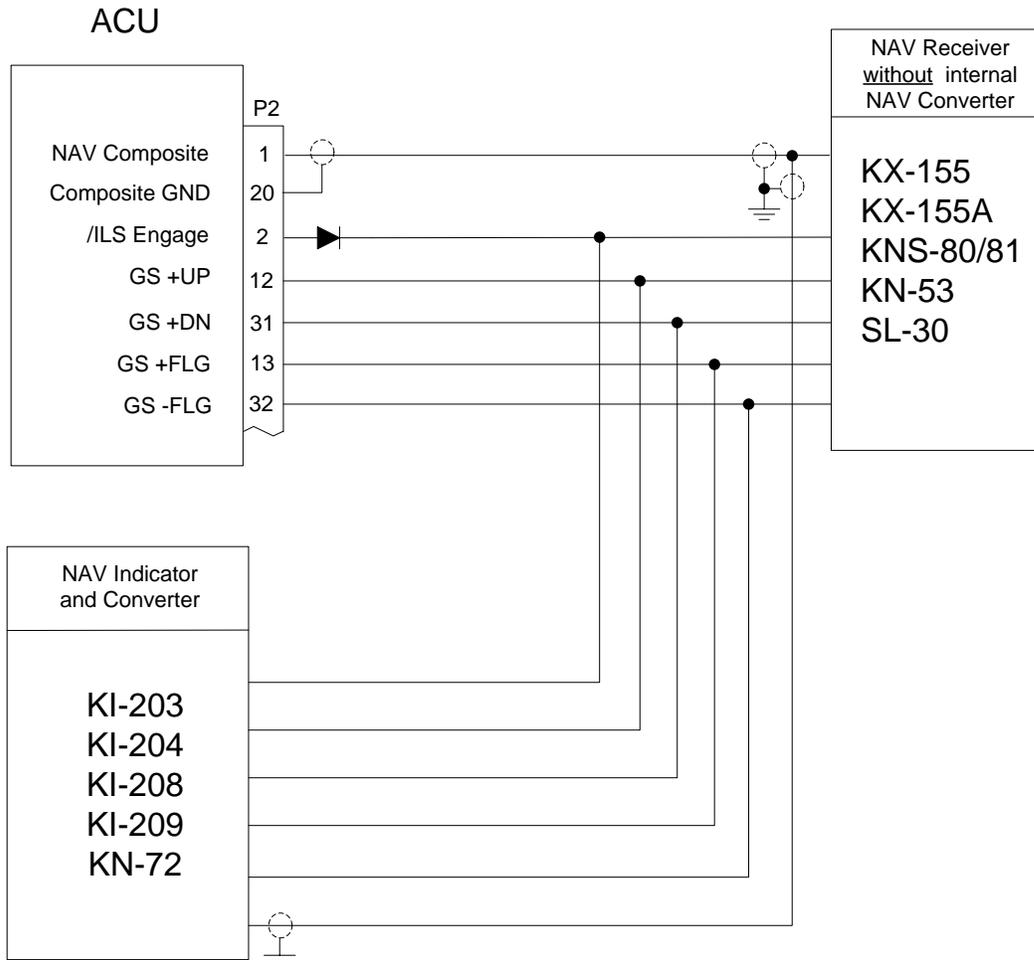

- 1 Parallel all lines shown maintaining shielding as required. Splice connections as close to NAV receiver as possible. Do not splice from back of NAV indicator.
- 2 GS lines will only be connected on NAV units with this option.
- 3 Some Nav Receivers have multiple GS outputs. Separate outputs should be used in lieu of paralleling the 4 wires when available.
- 4 KX-165 and KX-165A's may be connected as shown to these indicators or they may be connected to units with an OBS Resolver.
- 5 Complete ACU to NAV hook-up is shown on Figure 9-15.
- 6 Refer to manufacturers' documentation to verify the integration data and for information regarding checkout procedures. This drawing, as it pertains to the non-Aspen equipment, is for reference only.

Figure 9-24: Back-up NAV Indicator (Internal Converter)

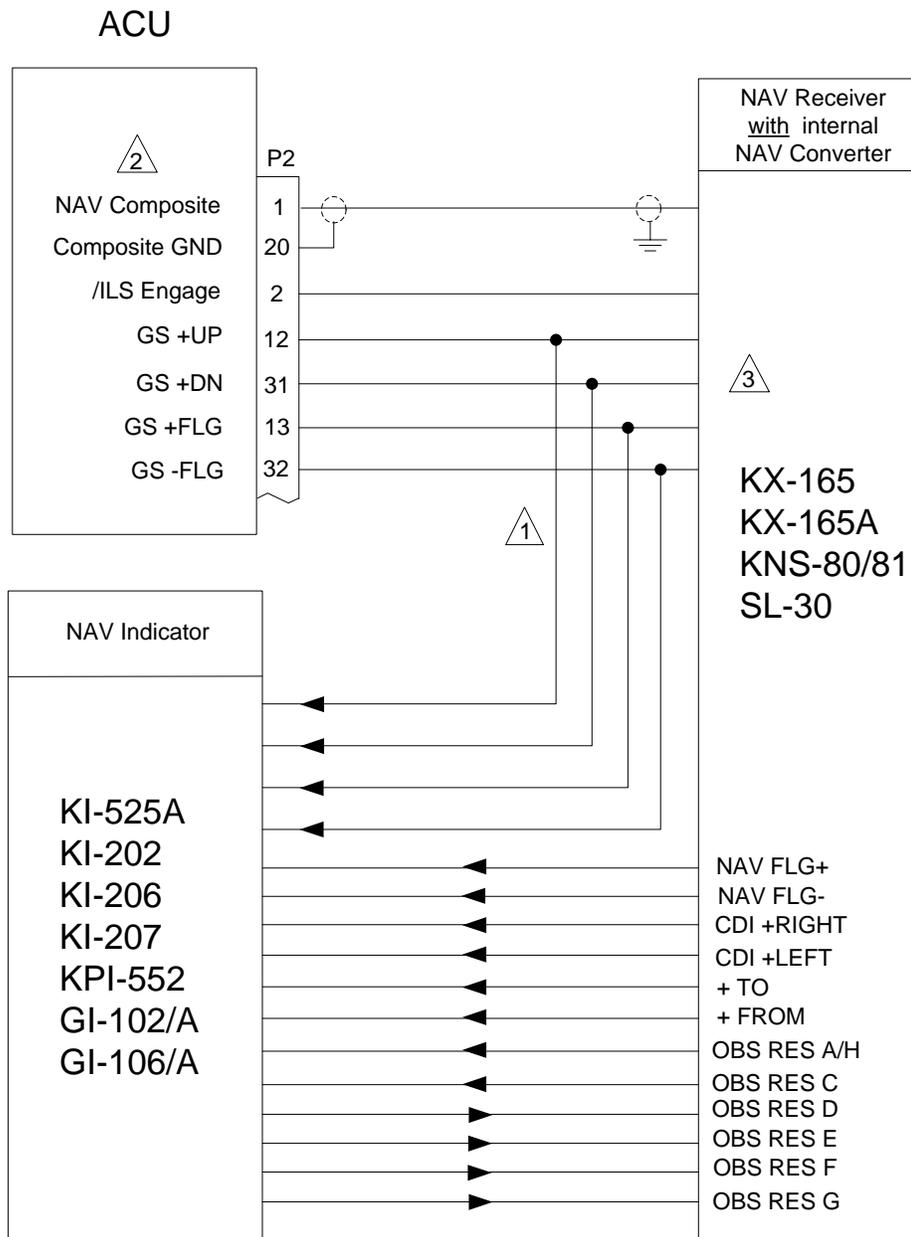

1 Parallel all lines shown maintaining shielding as required. Splice connections as close to NAV receiver as possible. Do not splice from back of NAV indicator.

2 Complete ACU to NAV hook-up is shown on Figure 9-15.

3 Some Nav Receivers have multiple GS outputs. Separate outputs should be used in lieu of paralleling the 4 wires when available.

4 Refer to manufacturers' documentation to verify the integration data and for information regarding checkout procedures. This drawing, as it pertains to the non-Aspen equipment, is for reference only.

Figure 9-25: Back-up NAV Indicator (OBS Resolver)

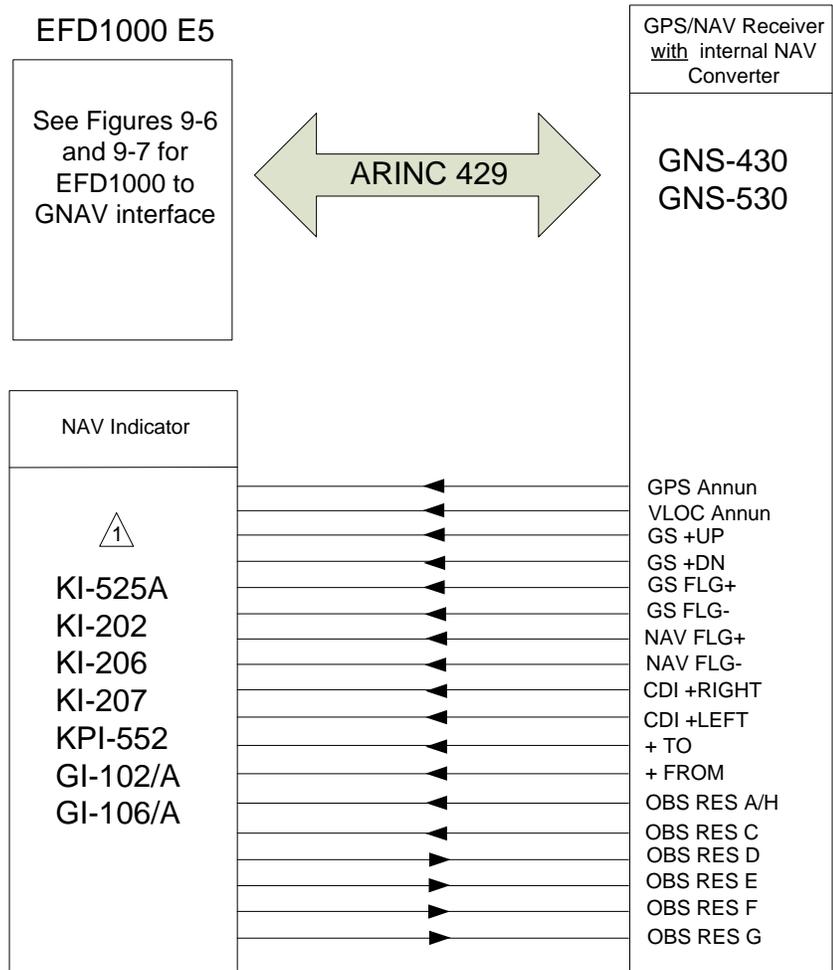

- 1 If connected to P4006/P5006 then the NAV indicator will be tied directly to the VLOC receiver and will be independent of any EFD indications. If connected to P4001/5001 then output switches between GPS and NAV with CDI Select button on GNS and operation is as below.
- 2 Complete EFD to GNS hook-up is shown on previous drawings.

- 3 If ARINC 429 connection is made the Garmin GPS will use the digital OBS from the PFD. If the digital OBS goes invalid it will then use the analog OBS from back-up NAV indicator.
- 4 Refer to manufacturers' documentation to verify the integration data and for information regarding checkout procedures. This drawing, as it pertains to the non-Aspen equipment, is for reference only.

**Operation when connected to P4001/5001:**

**GPS OBS Operation with an EFD1000 E5 and a Mechanical Standby Nav Indicator**

When the EFD1000 E5 and a mechanical standby Nav indicator are both connected to an integrated VOR/Localizer/GPS Navigation system, the standby indicator and the EFD1000 E5 operate normally in all VOR, GPS and localizer modes.

When the GPS OBS mode is selected, the EFD1000 E5 course selector commands the GPS OBS course and the mechanical standby nav indicator OBS course selector is ignored. The left/right indications are shown on both displays. When the EFD1000 E5 is turned off, the course selector on the mechanical standby Nav indicator commands the GPS OBS value.

**Course Pointer Operation with Integrated VOR/Localizer/GPS Navigation Systems**

During manual or automatic operation of the integrated system, when transitioning from GPS guidance to VOR or localizer guidance, ensure that the course pointer on the EFD1000 E5 is set to the appropriate course.

**Figure 9-26: Back-up NAV/GPS Indicator (GNS-430/530)**

**CNX-80/ GNS-480 (software 2.0 and below)**

This configuration is not authorized. The GNS-480 should be upgraded to software version 2.3 (see below)

**CNX-80/ GNS-480 (software 2.3)**

**GND MAINT - ARINC 429 SETUP**

CH_IN	SEL	SPEED	SDI
2	EFIS	LOW	See Note 1
CH_OUT	SEL	SPEED	SDI
1	*GAMA 429 GFX Int	LOW(2)	See Note 1
2	VOR/ILS	LOW(2)	SYS1 or SYS2

\*GAMA 429 GFX Int – this configuration has Flight Plan information.

**GND MAINT – MISCELLANEOUS SETUP**

CDI SELECT: **USE**

With this configuration the EFD1000 will read the GNS480 CDI logic state on the A429 bus and toggle between GPS and VLOC on the PFD when pressing the GNS480 CDI button.

EFD1000 will use GPS/NAV ID's A and B

**GNS-430/530(W) & GPS-400/500(W)**

**MAIN ARINC 429 CONFIG Page**

IN 1	LOW	Honeywell EFIS (when using pins 48/49) or EFIS or EFIS/ADC*
IN 2	As required	
OUT	LOW(2)	GAMA 429 Graphics w/INT
SDI	See Note 1	
VNAV	ENABLE LABELS (W models only)	

**VOR/LOC/GS ARINC 429 CONFIG Page**

SPEED	LOW(2) RX	LOW(2) TX
SDI	COMMON	

\* Note – Some GPS units require the EFIS config. ACU2 installs can use the EFIS/ADC config.

**GTN650/750 and GTN625/635/725**

**ARINC 429 CONFIG Page**

IN 1	LOW	EFIS Format 3 or EFIS Format 2 if ACU2 installed and using EFD1000 Air Data.
IN 2	As required	
OUT	LOW(2)	GAMA Format 3
SDI	See Note 1	

**VOR/LOC/GS ARINC 429 CONFIG Page**

SPEED	LOW(2) RX	LOW(2) TX
SDI	COMMON	

**LOW(2)**

The GPS/VOR buss speeds are typically set to low but if the ACU2 is used or it is required to use HS A429 for other devices these settings may need to be set to HI (Note if set to HI then the appropriate settings in the EFD1000 must be set to HIGH)

**NOTE 1 – GPS SDI Setting**

EFD1000 SW is v2.1 or below:  
Set the SDI to COMMON on all single and dual 430/530 and SYS1 or SYS2 for all single and dual GNS480.

EFD1000 SW is 2.2 and above:  
Single GNS/GTN set to COMMON, Single 480 set to SYS1 or SYS2.  
Dual GNS/GTN - Set to LNAV1(SYS1) for GPS1 and LNAV2(SYS2) for GPS2.

**GPS 155XL**

**429 IN** = SELECTED COURSE  
**429 OUT** = KING EFS 40/50

**KLN-94**

MAINTENANCE PAGE 7: \*STANDARD RS-232 or \*ENHANCED RS-232

\*See Table 5-3 for details

**Garmin SL-30**

The SL-30 can be connected to the EFD1000 in one of two ways. The Resolver configuration is preferred.

*Resolver:* The composite output from the SL-30 to the PFD will become invalid whenever VOR monitor mode or localizer back course is selected on the SL-30. The navigation source will show as failed on the PFD if either of these two modes is entered and the SL-30 is the selected navigation source. If connected, the backup NAV indicator will continue to function if either of these two modes is selected.

*Converter:* VOR monitor mode or localizer back course mode are disabled from selection on the SL-30. A backup NAV indicator (GI-106) cannot be connected without a KN-72 between the SL-30 and indicator due to the fact that the OBS resolver inputs become invalid with this configuration.

**GTX-330 (When used as a Data Concentrator)**

The ARINC channel that is connected to the EFD1000 (i.e. receiving the ARINC labels from the EFD1000) must be set to "AHRIS" on the GTX-330.

**Transponder or GPS using RS232 ADC Output**

**GTX-330** – configure for ADC W/ALT if using the EFD1000 as the encoding source. Configure for ADC NO ALT if EFD1000 is not to supply encoding source but is used for OAT/TAS and other labels.

**GNS430/530** – configure for Shadin-adc or Shadin.

**GTN6xx/7xx** – configure for Airdata Format 1 or Altitude Format 3 as desired.

**KLN90B** - no config required

**KLN89B/94** – Set RS232 Air Data = Y in Maintenance Pages.

**Figure 9-27: Non-Aspen Equipment Configuration Notes**

**RS-232 Heading & ADC**

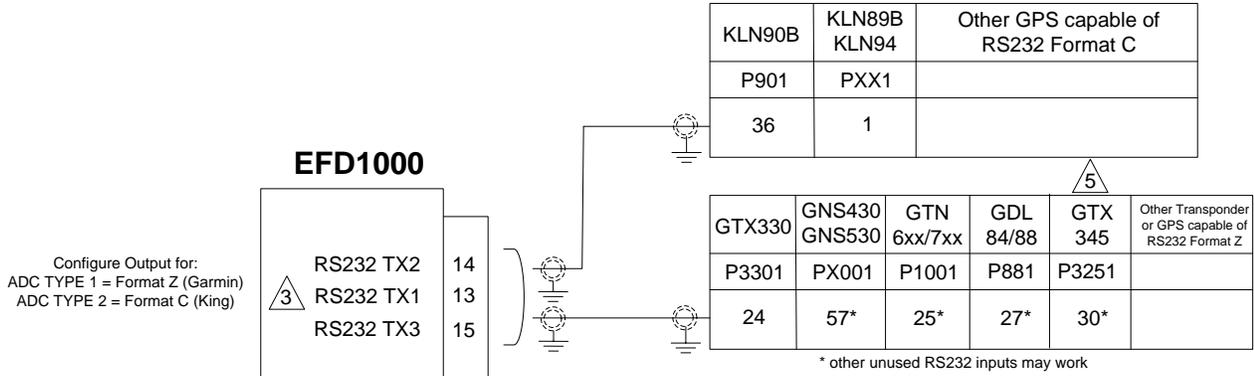

**ARINC 429 Heading & ADC**

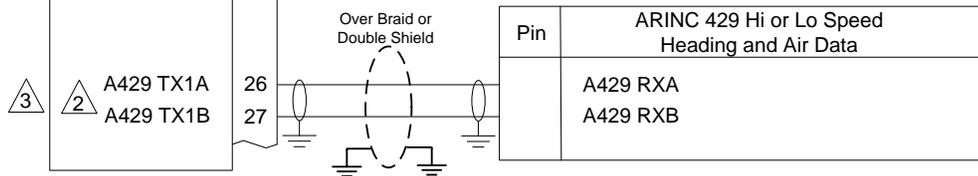

**ACU**

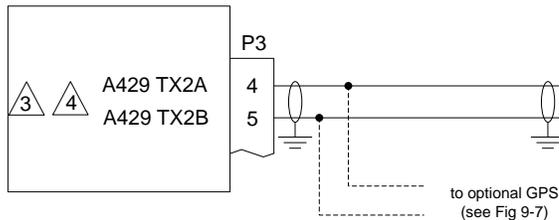

**ARINC 429 Heading**

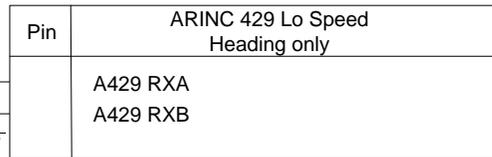

**ACU2**

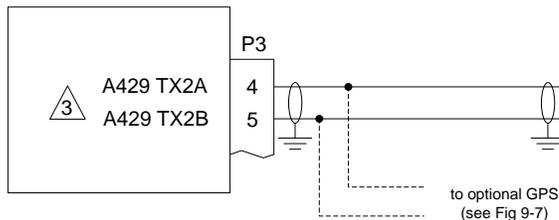

**ARINC 429 Heading & ADC**

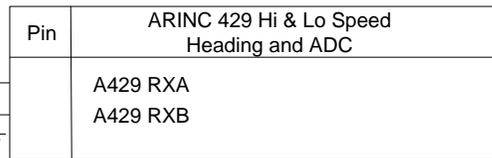

1 This note is not used

2 If ACU is installed parallel this EFD output with ACU and other device requiring A429 Heading and/or Air Data.

3 See Section 8 of this manual for complete list of RS232 and A429 labels supported.

4 ACU transmits low speed 429 only.

5 GTX 345 requires sw 2.05 or later

6 Refer to manufacturers' documentation to verify the integration data and for information regarding checkout procedures. This drawing, as it pertains to the non-Aspen equipment, is for reference only.

**Figure 9-28A: Digital Heading/ADC Outputs**

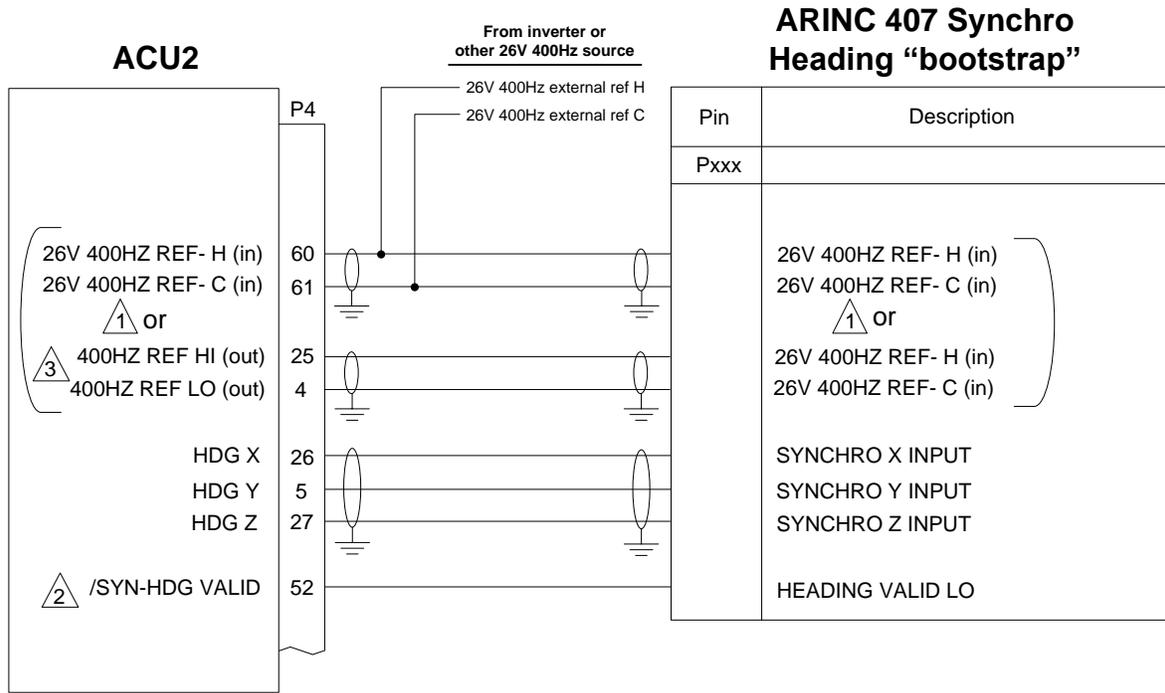

⚠ The ACU2 and the device requiring the synchro heading input must use the same 400HZ reference. Either wire the 400HZ from the external source in to both the ACU2 and the device or use ACU2 400HZ output as reference to device. Note if a external reference is connected to pins 60/61, the ACU2 will disable the internal 400HZ reference output on pins 25/4.

⚠ /SYN-HDG VALID is a active Lo output when the heading system is valid. If the device requires a active Hi input then use this output to drive a relay to invert the signal. This output can sink up to 100ma to ground.

⚠ ACU2 26Vrms@400Hz reference output can support up to 0.06VA. If more than one analog load is required use an external inverter.

⚠ Refer to manufacturers' documentation to verify the integration data and for information regarding checkout procedures. This drawing, as it pertains to the non-Aspen equipment, is for reference only.

Figure 9-28B: ARINC 407 Synchro Output (ACU2 only)

THIS PAGE IS INTENTIONALLY LEFT BLANK

## 10 Configuration and Equipment Checkout

Print a copy of Appendix B – Installation Final Check Sheet prior to starting any tests. Log a Pass/Fail on check sheet then sign and date upon completion. Include copy of form in permanent aircraft records.

**NOTE: To avoid damage to the equipment, do not place the EFD1000 E5 Display face down on the knobs.**

The following Test Equipment will be required to complete the remaining steps in the ground test procedure:

- Pitot Static Test Set
- NAV/ILS Signal Generator
- Digital Multimeter
- Electrical Bonding Tester

### 10.1 Wiring Checks

Do not install the EFD, ACU, RSM or configuration module until instructed to do so in Section 10.3.

- 1) Perform a continuity check on all wires between the EFD, ACU, RSM, Configuration Module and their associated connections per wiring diagrams.
- 2) Verify over shields or over braids are installed on required wiring bundles.
- 3) Apply aircraft power and close the EFD and ACU circuit breakers and the EFD master switch if installed.
- 4) Verify proper voltage on EFD main connector pins 1, 2, and 3 and that there are proper grounds on pins 4, 5, and 6.
- 5) If installed, verify proper voltage on ACU/ACU2 P1-10 and ground on P1-3.

### 10.2 Bonding Check – 14CFR 23.867(b)

- 1) Verify braided bonding strap is installed between EFD ground stud and airframe ground.
- 2) Verify EFD mounting bracket is bonded to instrument panel with no greater than 3 milliohms resistance.
- 3) Verify ACU chassis is bonded to airframe with no greater than 3 milliohms resistance.
- 4) Verify RSM base plate or doubler plate is bonded to airframe with no greater than 3 milliohms resistance.

### 10.3 Initial System Turn On

Remove power by pulling applicable circuit breakers. Install the EFD, ACU, RSM, and Configuration Module. Push in all applicable circuit breakers and apply power. Verify the EFD displays the initialization page after 5 seconds.

If a “Convert Config Module (CM)” message is displayed, press Convert. This will load the EFD software level configuration pages to the configuration module.

Configure all systems using Section 10.4 prior to system check out.

**NOTE:** AHRS Flags may take up to 3 minutes to clear. Airspeed and Altitude flags may take up to 20 minutes to clear at temperatures below  $-20^{\circ}\text{C}$ .

## 10.4 System Configuration

Configure the EFD1000 E5 system prior to running the ground test procedure. The configuration pages are accessed through the EFD display using the MENU button and the lower Right Control Knob labeled MODE/SYNC.

### 10.4.1 Main Menu Access

Pushing the “MENU” button accesses the Main Menu operation. See E5 Pilot Guide for Main Menu operation.

### 10.4.2 Menu Navigation

When no fields are enabled for editing, rotating the right control knob clockwise advances to the next menu page and counterclockwise advances to a previous menu page.

Editable menu items are displayed in white text on a blue background, non-editable menus items are green text on a blue background while grey text on a blue background is disabled from editing.

### 10.4.3 Edit Mode

Pushing the line select key adjacent to an editable field enables the associated field for editing. The field turns magenta when enabled and the right control knob reads “Edit Value”.

When the field is enabled for editing rotating the right control knob will adjust the value. Pushing the right control knob or the adjacent line select key will exit from the editable field.

### 10.4.4 Main Menu Configuration

The Main Menu consists of pages that are pilot selectable. Refer to the EFD1000 E5 Pilot Guide for Main Menu configuration if necessary.

### 10.4.5 Installation Menu – Unit Configuration

The Installation Menu is entered from the Main Menu’s “SYSTEM STATUS PAGE” (last page). Simultaneously push and hold the MENU key, Line Select Key #1 and Line Select Key #2 for 3 seconds while the airspeed is below 30 units.

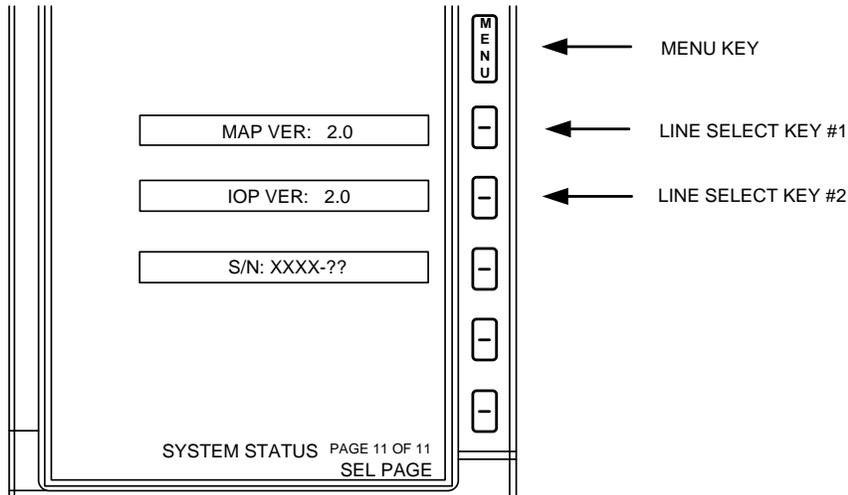

**Figure 10-1: Installation Menu Access**

Whenever the warning message in Figure 10-2 is displayed, pressing either control knob shall advance the Installation menu.



**Figure 10-2: Installation Menu Warning**

To exit the Installation Menu at any time press the MENU button. All data will be saved as displayed. The system will reboot and “INITIALIZING” will appear on the display for approximately 40 seconds.

Record aircraft information at the beginning of the section and record the configuration in each table as shown below.

Make a copy of the appropriate section with the information recorded for inclusion into the Instructions for Continued Airworthiness.

Use section 10.4.7- Configuration Definitions, to assist with configuration “Options” selection.

**EXAMPLE: Record Aircraft and Equipment Data**

Installation Date:	
Aircraft Model:	EFD1000 S/N:
Aircraft Type:	RSM S/N:
Aircraft S/N:	ACU S/N:
	CM S/N:

**EXAMPLE: Record installation as configured and wired**

INSTALLATION MENU PAGE 9 - ACU CONFIG		SW v1.0
Feature	Options	Actual Setting
ACU HSI TYPE	0,1 (0=KI525A, 1=NSD360)	
ACU FD TYPE	0,1,3,4 (0=NONE,1=KI256, 3=G550)	
ACU DATUM	NORMAL, REVERSED	
FD PITCH OFFSET ADJ	-10.0 to +10.0 (degrees)	
FD ROLL OFFSET ADJ	-10.0 to +10.0 (degrees)	
Notes:		

10.4.6 EFD1000 E5 Installation Menu Configuration

INSTALLATION MENU Configuration – EFD1000 E5

Installation Date:	
Aircraft Model:	EFD S/N:
Aircraft Type:	RSM S/N:
Aircraft S/N:	ACU S/N:
	CM S/N:

**WARNING:** Only an appropriately rated mechanic or repairman (14 CFR 43.3) may set the values on the IAS Config A and B menu pages. The values must match the certified speeds in the Aircraft Flight Manual (AFM), Pilot Operating Handbook (POH), or other legal form of documentation (e.g., Placard).

10.4.6.1 Installation Menu Page – IAS CONFIG A

All standard airspeed indicators (that use a Vne) will set the MOL TYPE to 1 and then enter the Vne in the MOL PARAM VALUE field. This includes all piston singles and twins.

Aircraft that use a Vmo/Mmo airspeed indicator will set the MOL TYPE to 2 thru 6. See Table 10–1 for MOL TYPE and MOL Parameter values. Set the MOL MARKER/BAND to either a BARBER POLE or REDLINE depending on existing airspeed indicator marking.

INSTALLATION MENU PAGE – IAS CONFIG A		
Feature	Options	Actual Setting
MOL TYPE	1,2,3,4,5,6	
MOL PARAM SEL	See instructions in table 10–1	
MOL PARAM VALUE	See instructions in table 10–1	
MOL MARKER/BAND	BARBER POLE, REDLINE	
MACH DSPL TYPE	Not applicable	
Notes:		

MOL Type	MOL Parameter Selection Options (Known Values)	Description And Example
1	Vne	For this type, Vne is displayed as a fixed value. Set MOL TYPE = 1 Example: If Vne = 180Kts, enter 180 in the MOL PARAM VALUE field.
2	Vmo	For this type, Vmo is displayed as a fixed value. Set MOL TYPE =2 Example: If Vmo = 210Kts, enter 210 in the MOL PARAM VALUE field.
3	Vmo	For this type, Vmo and Mmo are known values. MAX ALT is the service ceiling of the aircraft. Set MOL TYPE=3. Push line select key next to MOL PARAM SEL and scroll to Vmo. Press line select next to MOL PARAM VALUE and rotate right knob until Vmo value is correct. Repeat for Mmo and MAX ALT
	Mmo	
	MAX ALT	
4	Vmo1	For this type, Vmo is displayed as a fixed value to a known altitude and then Vmo decreases by # knots per # feet (were # is a number)  Example: Vmo is 226 KIAS to 15,500 feet and then Vmo decreases 4 KIAS per 1,000 feet Known values: Vmo=226, ALT1=15500, KNOTS=4, ALT2=1000, MAX ALT = A/C service ceiling. Use MOL PARAM SEL to select Vmo/ALT1/KNOTS/ALT2 Use MOL PARAM VALUE to enter 226/15500/4/1000
	ALT 1	
	KNOTS or MPH <i>(depending on the setting on the IAS UNIT installation menu setting)</i>	
	ALT 2	
	MAX ALT	
5	Vmo 1	For this type, the aircraft has multiple Vmo's (Vmo x) that depend on different altitudes (ALT x).  Example: Vmo = 160 KIAS from 0 ft. to 5000 ft. Vmo = 155 KIAS from 5000 ft. to 10000 ft. Vmo = 145 KIAS from 10000 ft. to 15000 ft.  In this example Vmo1=160, ALT1=5000, Vmo2=155, ALT2=10000, Vmo3=145, ALT3=15000  This type can support up to 6 Vmo's.
	ALT 1	
	Vmo2	
	ALT 2	
	Vmo 3	
	ALT 3	
	Vmo 4	
	ALT 4	
	Vmo 5	
	ALT 5	
	Vmo 6	
ALT 6		
6	Vmo 1	For this type, Vmo (Vmo1) is displayed as a fixed value to a known altitude (ALT1) and then Vmo decreases in a straight-line variation between the Vmo1 altitude and a Vmo2 altitude (ALT2). ALT2 = aircraft maximum altitude.  Example: Vmo = 197 KIAS from 0 ft. to 15000 ft. Vmo = 160 KIAS at 25000 ft.  In this example Vmo1=197, ALT1=15000, Vmo2=160, ALT2=25000

**Table 10-1 MOL Type and Parameter Descriptions**

10.4.6.2 Installation Menu Page – IAS CONFIG B

Set Speed Bands per Aircraft Flight Manual. Note– Vne is set on previous page.

INSTALLATION MENU PAGE – IAS CONFIG B		
Feature	Options	Actual Setting
OVERSPEED ALERT	Not applicable	
Vno	0 to 450	
Vfe	0 to 450	
Vs	0 to 450	
Vso	0 to 450	
Notes:		

10.4.6.3 Installation Menu Page – IAS CONFIG C

Set Speed Markers per Aircraft Flight Manual.

INSTALLATION MENU PAGE – IAS CONFIG C		
Feature	Options	Actual Setting
Vyse	0 to 450	
Vmc	0 to 450	
Triangle	0 to 450	
Not Used		
Not Used		
Notes:		

10.4.6.4 Installation Menu Page – IAS CONFIG D

**NOTE: These selections are rotorcraft only and are grayed out.**

Does not apply to EFD1000 E5

10.4.6.5 Installation Menu Page – IAS CONFIG E

This menu is used to select the color of the airspeed tape speed bands so that they can exactly match the existing airspeed indicator.

**SPD Band 2** – Maximum structural cruising speed (Vno) to the never exceed speed (Vne). Yellow is the default for piston engine aircraft. Set as required to match existing IAS indicator.

**SPD Band 3** – No flap stall speed (Vs) to the maximum structural cruising speed (Vno). Green is the default for piston engine aircraft. Set as required to match existing IAS indicator.

**SPD Band 4** – Full flap stall speed (Vso) to the maximum flap extend speed (Vfe). White is the default for piston engine aircraft. Set as required to match existing IAS indicator.

**Note:** “CLEAR” will render a tape marking (Speed Band) with no color, which will replicate certain Vmo/Mmo mechanical airspeed indicators such as ones with a black background with white tick marks and numbers.

INSTALLATION MENU PAGE – IAS CONFIG E		
Feature	Options	Actual Setting
SPD Band 2	YELLOW, CLEAR	
SPD Band 3	GREEN, WHITE, CLEAR	
SPD Band 4	WHITE, CLEAR	
Not Used		
Not Used		
Notes:		

**10.4.6.6 Installation Menu Page – IAS CONFIG F**

**IAS UNITS** – Set per Aircraft Flight Manual.

**TAPES** and **VPSD EDIT** – See section 10.4.7 for definitions of settings.

INSTALLATION MENU PAGE – IAS CONFIG F		
Feature	Options	Actual Setting
IAS UNITS	kts, mph	
TAPES	UNLOCKED, LOCK OFF, LOCK ON	
VSPD EDIT	UNLOCKED, LOCKED	
Not Used		
Not Used		
Notes:		

**10.4.6.7 Installation Menu Page – IAS CONFIG G**

**IAS DISPLAY** – DISABLE will remove the airspeed bug from the tape, the upper left window, and the left knob. The window will continue identify the units (KTS or MPH) displayed on the airspeed tape.

**ALT DISPLAY** – DISABLE will remove the altitude bug from the tape, the upper right window, and the right knob. It also removes the MIN field.

**BARO DISPLAY** – When disabled will remove the BARO setting from the right knob and the BARO display from the center Databar. The Disable setting will also remove the baro-corrected altitude label from the A429 and RS-232 busses.

**VSI DISPLAY** – Always On means the tape will always be displayed. Always Off means the tape is always turned off. AUTO means the tape will declutter when the vertical speed is between +/-100fpm. ALWAYS ON or AUTO are the only settings permitted under this STC.

**CAUTION:** Setting **BARO DISPLAY** to **DISABLE** may only be used when the **TAPES** are Locked Off.

INSTALLATION MENU PAGE - IAS CONFIG G		
Feature	Options	Actual Setting
IAS DISPLAY	DISABLE, ENABLE	
ALT DISPLAY	DISABLE, ENABLE	
BARO DISPLAY	DISABLE1, ENABLE 1(read Caution above)	
VSI DISPLAY	ALWAYS ON, ALWAYS OFF, AUTO*	
Not Used		
Notes: * ALWAYS ON or AUTO are the only permitted settings under this AML-STC		

**10.4.6.8 Installation Menu Page - NAV SETUP A**

The following menu will be used to configure the EFD1000 E5 system for the installed GPS, NAV and autopilot interfaces. The installation wiring diagrams in Section 9 have a Configuration Matrix table that will be used to set ID#1 and ID#2.

INSTALLATION MENU PAGE - NAV SETUP A		
Feature	Options	Actual Setting
GPS/NAV #1	NONE*,A,B,C,D,E,G,H,I*,M*	
GPS/NAV #2	NONE	
Not Used		
Not Used		
Not Used		
*Note - NONE, I, and M config is only permitted if the aircraft is Limited to VFR.		

**10.4.6.9 Installation Menu Page - NAV SETUP B**

The following menu will pre-fill based on the GPS/NAV selections made on the previous page. No changes required here unless it is required to change the GPS1/NAV1 order to accommodate parallel connection of the EFD1000 and a second device.

INSTALLATION MENU PAGE - NAV SET UP B		
Feature	Options	Actual Setting
429 IN PORT 1	NONE, GPS1, VLOC1, VLOC1+ACU, GPS1+ACU, GPS1+ACU+VLOC1	
429 IN PORT 2	NONE, GPS1, VLOC1, VLOC1+ACU, GPS1+ACU, GPS1+ACU+VLOC1	
429 IN PORT 3	Not applicable	
429 IN PORT 4	Not applicable	
429 IN PORT 5	NONE	

10.4.6.10 Installation Menu Page – NAV SETUP C

A429 input ports will be set to HIGH or LOW.

INSTALLATION MENU PAGE – NAV SET UP C		
Feature	Options	Actual Setting
429 OUT PORT SPEED	HIGH, LOW <sup>(1)</sup>	
429 IN PORTS 1 & 2 SPEED	HIGH, LOW <sup>(1)</sup>	
429 IN PORTS 3 & 4 SPEED	Not applicable	
ADF CONFIG	Not applicable	
NAV #2 POSITION SOURCE	Not applicable	
<sup>(1)</sup> ACU set to LOW. ACU2 set to HIGH		

**NOTE:** Power to the ACU2 should be reset after configuring the EFD because if it was running low speed when powered up, it will continue to run low speed even if changed to high above until it boots back up.

10.4.6.11 Installation Menu Page – RS-232 CONFIG A

The following menu is used to configure the RS-232 RX IN sensor ports. Options include GPS type. Note – some ports do not include all interface options. (See wiring diagrams in sections 9 to determine how each port was wired and configure port accordingly.)

INSTALLATION MENU PAGE – RS-232 CONFIG A		
Feature	Options	Actual Setting
232 IN PORT 0	NONE	
232 IN PORT 1	NONE, GPS TYPE 1, GPS TYPE 2, GPS TYPE 3	
232 IN PORT 2	NONE, GPS TYPE 1, GPS TYPE 2, GPS TYPE 3	
232 IN PORT 3	NONE	
232 IN PORT 4	NONE	
Notes: GPS TYPE 1= KLN94/90B “standard”, GPS TYPE 2= KLN94 Enhanced, GPS TYPE 3= GX50/55/60/65.		

**10.4.6.12 Installation Menu Page – RS-232 CONFIG B**

The following menu is used to configure the RS-232 RX IN 5 sensor port and the four RS-232 TX OUT ports. Options include ADC (two types). Note – some ports do not include all interface options. (See wiring diagrams in sections 9 to determine how each port was wired and configure port accordingly.)

INSTALLATION MENU PAGE – RS-232 CONFIG B		
Feature	Options	Actual Setting
232 IN PORT 5	NONE	
232 OUT PORT 0	NONE	
232 OUT PORT 1	NONE, ADC TYPE 1, ADC TYPE 2	
232 OUT PORT 2	NONE, ADC TYPE 1, ADC TYPE 2	
232 OUT PORT 3	NONE, ADC TYPE 1, ADC TYPE 2	
Notes: ADC TYPE 1="Z" (Shadin) format, ADC TYPE 2="C" (Bendix King C) format		

**10.4.6.13 Installation Menu Page – RS-232 CONFIG C**

This page is not applicable to the EFD1000 E5

**10.4.6.14 Installation Menu Page – ACU CONFIG A**

The following menu configures the emulation modes for the Flight Director and HDG and CRS Datum interfaces. The installation wiring diagrams in Section 9 have a Configuration Matrix table that will be used to set ACU HSI TYPE and ACU FD TYPE. (See Section 10.4.7 for example).

INSTALLATION MENU PAGE – ACU CONFIG A		
Feature	Options	Actual Setting
ACU HSI TYPE	0,1,2,3	
ACU FD TYPE	Not applicable	
ACU DATUM	NORMAL, REVERSED	
FD PITCH OFFSET ADJ	Not applicable	
FD ROLL OFFSET ADJ	Not applicable	

**10.4.6.15 Installation Menu Page – ACU CONFIG B**

The ACU/ACU2 transmit buss speed to the GPS receiver and receive buss speed from the digital VLOC receiver will be configured. For ACU set both to LOW. ACU2 may change these to HIGH if required and applicable, but most configurations as shown in Section 9 use Low speed settings.

INSTALLATION MENU PAGE – ACU CONFIG B		
Feature	Options	Actual Setting
Digital Nav Tx Speed	HIGH, LOW	
Digital Nav Rx Speed	HIGH, LOW	
STEC55X A/P	Not applicable	
Not Used		
Not Used		
Notes: <sup>(1)</sup> Tx Speed is ACU P3 pins 4&5, Rx Speed is ACU P1 pins 1&2		

**10.4.6.16 Installation Menu Page – MISC CONFIG A**

*RSM Orientation-* TOP (-001, and -002 RSM), BOTTOM (-003 RSM)

INSTALLATION MENU PAGE – MISC CONFIG A		
Feature	Options	Actual Setting
RSM Orientation	TOP, BOTTOM (Inverted orientation)	
RSM GPS Enable	Not applicable	
RSM GPS USAGE	Not applicable	
RAD ALT CONFIG	Not applicable	
WIND DISPLAY	Not applicable	

**10.4.6.17 Installation Menu Page – MISC CONFIG B**

The following menu will be used to set the aircraft electrical system voltage. EFD Battery Config will be set to INTERNAL. The Panel Tilt Pitch Adj is aligned for tilted instrument panels and the Panel Roll Adj is adjusted to compensate for slightly misaligned EFD mounting in the instrument panel. See Section 10.4.7 for instructions on setting the Panel Tilt Pitch Adj, Panel Roll Adj, and Attitude Ref Symbol adjustments.

INSTALLATION MENU PAGE – MISC CONFIG B		
Feature	Options	Actual Setting
ELEC SYSTEM	14 VOLT, 28 VOLT	
EFD BATTERY CONFIG:	INTERNAL	
ATTITUDE REF SYMBOL ADJ:	-5.0 to +5.0 degrees	
PANEL TILT PITCH ADJ	-10.0 to +20.0 degrees	
PANEL ROLL ADJ	-2.0 to +2.0 degrees	

**10.4.6.18 Installation Menu Page – MISC CONFIG C**

**COMPOSITE PHASE (VOR1,2)** – If the analog NAV receiver has a 180° phase shifted output (i.e.,RT-385) then select 180 for VOR1.

**GPSS GAIN** – 1.0 is default, Rate Based autopilots may need a setting of up to 2.0.

**CRS SDI** – For a dual A429 GPS interface set to NAV 1/2 and set GPS1 for SDI=LNAV1 and GPS2 for SDI=LNAV2. All other GPS configurations set to COMMON. See Figure 9-27.

INSTALLATION MENU PAGE – MISC CONFIG C		
Feature	Options	Actual Setting
COMPOSITE PHASE (VOR1,2)	(0,0) (180,0)	
GPSS GAIN:	0.5 to 2.0 (0.1 increments)	
CRS SDI	COMMON, NAV 1/2	
OBS DISPLAY	Not applicable	
Pitch Sync for Helicopters	Not applicable	

**10.4.6.19 Installation Menu Page – MISC CONFIG D**

This page not applicable to the EFD1000 E5

**10.4.6.20 Installation Menu Page – RSM CALIBRATION**

The following menu will be used in the next section to calibrate and validate the magnetometer in the RSM. Heading errors of up to +/- 6.0° can be calibrated at 30° increments beginning with North. (Follow RSM Cal procedure in Section 10.5.)

INSTALLATION MENU PAGE – RSM CALIBRATION	
Feature	Options
START CALIBRATION	Press to Initiate
ACCEPT CALIBRATION?	Press to ACCEPT Cal
REJECT CALIBRATION?	Press to REJECT Cal
HDG SEL	030° to 360° (in 30° increments)
HDG ADJ	-6.0 to +6.0 (degrees)
Notes:	

This table is used to record the HDG ADJ values used to bring the compass heading values in to specification.

RSM CALIBRATION	PAGE 12	Options	Actual Setting
HDG SEL: 030	KEY 4		
HDG ADJ:	KEY 5	Editable: -6 to +6	
HDG SEL: 060	KEY 4		
HDG ADJ:	KEY 5	Editable: -6 to +6	
HDG SEL: 090	KEY 4		
HDG ADJ:	KEY 5	Editable: -6 to +6	
HDG SEL: 120	KEY 4		
HDG ADJ:	KEY 5	Editable: -6 to +6	
HDG SEL: 150	KEY 4		
HDG ADJ:	KEY 5	Editable: -6 to +6	
HDG SEL: 180	KEY 4		
HDG ADJ:	KEY 5	Editable: -6 to +6	
HDG SEL: 210	KEY 4		
HDG ADJ:	KEY 5	Editable: -6 to +6	
HDG SEL: 240	KEY 4		
HDG ADJ:	KEY 5	Editable: -6 to +6	
HDG SEL: 270	KEY 4		
HDG ADJ:	KEY 5	Editable: -6 to +6	
HDG SEL: 300	KEY 4		
HDG ADJ:	KEY 5	Editable: -6 to +6	
HDG SEL: 330	KEY 4		
HDG ADJ:	KEY 5	Editable: -6 to +6	
HDG SEL: 360	KEY 4		
HDG ADJ:	KEY 5	Editable: -6 to +6	

**10.4.6.21 Installation Menu Page – ACCEL BIAS CAL**

This page is for Factory Calibration only and has no installation purpose.

**10.4.6.22 Installation Menu Page – WX-500**

This page not applicable to the EFD1000 E5

**10.4.6.23 Installation Menu Page – DFC A/P CONFIG PAGE A**

This page not applicable to the EFD1000 E5

**10.4.6.24 Installation Menu Page – DFC A/P CONFIG PAGE B**

This page not applicable to the EFD1000 E5

**10.4.6.25 Installation Menu Page – AOA CONFIG**

This page not applicable to the EFD1000 E5

**10.4.6.26 Installation Menu Page – NETWORK PAGE**

This menu is for diagnostic purposes only, unless an EA100 is installed.

For EA100 installations verify the following:

- 1) IP ADDR is set to **192.168.28.12**
- 2) SUBNET MASK to **255.255.255.0**
- 3) GATEWAY to **0**
- 4) PORT to **8550**

Use the line select key next to IP ADDR and the right knob to set the value. Subsequent pushes of the line select key will advance the cursor to the right so that each set of digits between the decimal points may be entered.

INSTALLATION MENU PAGE – NETWORK PAGE		SW v2.0 and above
Feature	Options	
IP ADDR	0-255	
SUBNET MASK	0-255	
GATEWAY	0-255	
PORT	0-9999	
Not Used		
Notes: Repeated presses of top 3 line select keys will select one of 4 selectable fields		

10.4.6.27 Installation Menu Page – DIAGNOSTICS

This menu is for diagnostic purposes only. Note – Operational Time and Flight Time are stored in the configuration module of the aircraft and these times are cumulative for the installation not the EFD unit itself.



Figure 10–3: Notional Diagnostics Page

**EXITING / SAVING DATA** – To exit the Installation Menu press the MENU button. All data will be saved as it was displayed on each page. The system will reboot and “INITIALIZING” will appear on the display for approximately 40 seconds. Normal operation continues.

10.4.7 Configuration Definitions

This section contains an expanded definition of each menu feature and detailed instructions for the available configuration options.

10.4.7.1 IAS Configurations

- Vne:** Never Exceed speed (beginning of red band)
- Vmo:** Maximum Operating Speed
- Mmo:** Maximum Operating Mach number
- Vno:** Maximum Structural Cruise speed (beginning of yellow band). For aircraft with no published yellow speed band set Vno = Vne.
- Vfe:** Maximum Flap Extend speed (top of white band) – set to Vfe = Vs on aircraft with no flaps

- Vs:** No Flap Stall speed (bottom of green band)
- Vso:** Full Flap Stall speed (bottom of white band) – set to  $V_{so} = V_s$  on aircraft with no flaps
- Vyse:** Single Engine best rate of climb (blue marker) on multi engine aircraft – set to zero “0” on single engine aircraft.
- Vmc:** Single Engine minimum control speed (red marker) on multi engine aircraft – set to zero “0” on single engine aircraft.
- ◁ Initial Flap Extension Speed – set to zero “0” on aircraft without a published initial flap extension speed. For aircraft that have a published speed at which the first notch of flap may be deployed, set to that published value.

**IAS UNITS:** Set to Knots or MPH as defined in the AFM

**TAPES:**

UNLOCKED = Must only be set when Airspeed and Altimeter are still in basic T configuration. With this setting the pilot can turn airspeed and altitude tapes on or off via menu.

LOCK OFF\* = Must be used if the airspeed tape on the EFD cannot be configured to look exactly like the mechanical indicator. Tapes are turned off and cannot be turned on by pilot.

LOCK ON = Tapes are always enabled and cannot be turned off by pilot.

**\*NOTE:** *Tapes cannot be locked off unless the airspeed indicator and altimeter are located in the original basic “T” configuration.*

**VSPD EDIT:**

UNLOCKED = Pilot can modify value of VSPEED textual markers in the Main Menu.

LOCKED = Pilot cannot modify the values of the VSPEED textual markers in the Main Menu.

#### 10.4.7.2 PANEL TILT PITCH ADJ

This setting is used to compensate for aircraft instrument panels that are inclined with respect to the aircraft leveling indices. The EFD1000 AHRS performance and the RSM calibration depend on the AHRS sensor orientation to the aircraft waterline using the aircraft leveling indices.

***CAUTION:*** *Do not use the “PANEL TILT PITCH ADJ” adjustment to align the Aircraft Reference Symbol to a zero pitch mark for level flight. Though such an adjustment appears to be a natural step, incorrect adjustment may result in incorrect pitch, roll and heading values. For non-tilted panel installations, the EFD1000 AHRS must show zero degrees pitch when the aircraft is leveled using the aircraft leveling indices. Adjustment of the PANEL TILT*

*PITCH ADJ to set the Aircraft Reference Symbol to a zero pitch mark for level-flight may result in improper EFD alignment. If the level flight level zero pitch reference needs adjustment, proceed in accordance with the ATTITUDE REF SYMBOL ADJ procedure described below.*

**NOTE:** *Once the EFD is installed and properly aligned, the Aircraft Reference Symbol's level-flight pitch attitude indication changes with speed and aircraft loading and cannot be adjusted by the pilot. See 14CFR 23.1303(f). See ATTITUDE REF SYMBOL ADJ adjustment to determine if further action is required.*

Adjust the PANEL TILT PITCH ADJ value using one of the two methods shown below.

#### **Method 1 — Using an Inclinometer**

Using an inclinometer and the aircraft leveling indices, measure the offset angle in degrees ( $\pm 0.5^\circ$ ), from aircraft level. This reading should be taken when a technician is seated in the cockpit since the angle could shift when the technician boards the aircraft. This measurement will be entered in the EFD1000 as CORRECTED PITCH ATTITUDE. Nose high is + degrees.



CORRECTED PITCH ATTITUDE: 2.0°  
CORRECTED ROLL ATTITUDE: 0.3°

*Figure 10-4: Illustration of aircraft 2° nose high*

- 1) Set the ATTITUDE REF SYMBOL ADJ to 0.0°.
- 2) Press the PANEL TILT PITCH ADJ line select key and use the bottom right knob to enter a value for PANEL TILT PITCH ADJ that results in the CORRECTED PITCH ATTITUDE (Figure 10-4) equaling the value read on the inclinometer. It may also be set to the amount of panel tilt as determined through measurement.
- 3) Press the PANEL TILT PITCH ADJ line select key.

#### **Method 2 – Leveling the Aircraft**

Level the airplane in pitch in accordance with the aircraft manufacturer's procedure. Then change the PANEL TILT PITCH ADJ adjustment to make the CORRECTED PITCH ATTITUDE equal to 0.0°.

- 1) Level the aircraft in pitch using the aircraft manufacturer's procedure.



CORRECTED PITCH ATTITUDE: 0.0°  
CORRECTED ROLL ATTITUDE: 0.0°

*Figure 10-5: Illustration of Zero degree pitch adjustment*

- 2) Set the ATTITUDE REF SYMBOL ADJ to 0.0°.
- 3) Press the PANEL TILT PITCH ADJ line select key and use the bottom right knob to enter a value for PANEL TILT PITCH ADJ that will result in the CORRECTED PITCH ATTITUDE equaling 0.0°.
- 4) Press the PANEL TILT PITCH ADJ line select key.

**10.4.7.3 PANEL ROLL ADJ**

Panel Roll Adjust is used to align the roll reference mark of the EFD1000 to zero degrees when the aircraft is wings level. With the aircraft wings level change the Panel Roll Adjust adjustment to make the CORRECTED ROLL ATTITUDE equal to 0.0°. Should more than 2° of correction be required the mechanical mounting of the EFD1000 for level in the panel should be re-verified.

***CAUTION: A RSM Calibration must be performed before first flight after changing either the PANEL TILT PITCH ADJ or PANEL ROLL ADJ values.***

**10.4.7.4 ATTITUDE REF SYMBOL ADJ**

This is used to make small changes to the pitch attitude reference mark on the EFD1000 should the aircraft fly consistently slightly nose high or nose low in cruise trim. It is not necessary to perform the RSM Calibration after making changes to this setting.

**10.4.8 NAV Setup Configuration**

**10.4.8.1 GPS/NAV#1 (ID#1)**

Ranges from A to H as specified on the wiring diagrams of Section 9. See example below.

ID#1	ID#2	Description
G	NONE	GPS1, No NAV1, No NAV2
H	NONE	GPS1,NAV1, No NAV2

*Figure 10-6: GPS/NAV Example*

**10.4.8.2 COMPOSITE PHASE (VOR1, VOR2)**

Most modern navigation receivers will be set to (0, 0) as VOR1 and VOR2 will have VOR composite outputs with zero degree phase shift. For receivers with VOR composite outputs that are 180° out of phase (i.e., ARC RT-385) set to 180 as required.

**10.4.9 ACU Configuration**

**10.4.9.1 ACU HSI TYPE**

- 0= KI-525A, Emulates the KI-525A HSI
- 1= NSD-360A, Emulates the NSD-360A HSI
- 2= reserved
- 3= PN-101

Below is an example from Figure 9-16 showing a KI-525A Emulation with a Bendix King autopilot. In this case you would set the ACU HSI TYPE =0:

Configuration Matrix  
(see Section 10)

ACU HSI TYPE = 0

Figure 10–7: HSI Type Example

#### 10.4.9.2 ACU DATUM

0 = Normal

1 = Reversed. It may be necessary to select “Reversed” if the HDG or CRS Datum drives the autopilot in the opposing direction. Some HSI units use reversed logic for CRS and HDG Datum. Verify through ground test the proper setting.

#### 10.4.9.3 EXITING / SAVING DATA

To exit the Installation Menu press the MENU button. All data will be saved as it was displayed on each page. The system will reboot and “INITIALIZING” will appear on the display for approximately 40 seconds. Normal operation continues.

### 10.5 RSM Calibration

#### 10.5.1 Calibration Overview

The Remote Sensor Module must be calibrated by performing a compass swing in the aircraft for any new installations and any follow up maintenance activities that could affect RSM accuracy.

Such activities might include but are not limited to the replacement of the RSM, replacement of the Configuration Module, installation of a mechanical or electrical device in the vicinity to the RSM, installation of an appliance that might generate a magnetic interference.

An overview of the RSM Calibration procedure is as follows (see Figure 10–10):

***CAUTION:*** *When a Calibration is initiated, the aircraft must be turned as described below. If the calibration is initiated and then accepted without moving the aircraft, an erroneous calibration will be written to the Configuration Module, potentially resulting in failure to initialize.*

- A heading will be checked to verify the reasonableness of EFD heading prior to calibration.
- The aircraft will be taxied to a magnetically quiet and level area at least 200ft from metal buildings and clear of metal grates, manhole covers and rebar within the concrete. A Compass Rose is ideal for this procedure.
- The aircraft can start from any heading.

- With engines running, all electrical equipment operating, and the aircraft stationary the RSM CAL page will be entered and Start Calibration will be initiated (see Figure 10–11).
- After a 15 second countdown timer the pilot/operator will begin to taxi the aircraft in a circle (cw or ccw) with the radius of approximately twice the length of the aircraft’s wing as viewed from the cockpit ( $\approx 30\text{ft}$ ).
- The aircraft will be taxied under its own power at a constant rate around a circle until a 60 second timer elapses. The aircraft must not stop until the timer has exhausted.
- At the completion of the 60 seconds the aircraft will have made at least a  $450^\circ$  circle ( $360^\circ + 90^\circ$ ) to approximately two complete circles ( $720^\circ$ ).
- At the end of the 60–second timer four headings about  $90^\circ$  apart will be checked against a calibrated heading source (i.e., site compass, compass rose).
- If EFD heading is acceptable then the calibration is Accepted.
- If the EFD heading is not within tolerance then it is Rejected and the calibration procedure is re–run.
- After the calibration is accepted headings are checked using a calibrated reference (i.e., a sight compass) every  $30^\circ$  (starting from North) to verify that the heading accuracy is within  $\pm 4^\circ$ .

**10.5.1.1 Second Phase RSM Location Evaluation**

As a second check against potentially damaging magnetic interference near the RSM it is required that the following test be run. The handheld compass test in section 6 usually does an acceptable job of locating a magnetically quiet area for mounting a RSM but does not take out all the factors such as ferrous RSM mounting hardware and an RSM that may have come in contact with a magnet due to poor handling and mounting practices. Follow the instructions below to fill in Table 10–3.

STEP	Example	Actual
Vertical Component (Z) from NOAA (nT)	40,422.2nT (Los Angeles)	
Vertical Component (Z) from NOAA converted by moving the decimal 5 places to left	.40	Z1
Vertical Component (Z) from EFD1000 (RSM level within 5 degrees)	.37	Z2
Vertical Component (Z) Average of North and South reading (RSM tilted more than 5 degrees)	Not required as RSM was within $5^\circ$	Z2
Add 0.1 to the Z1 box above	$.40 + .1 = .50$	Z3
Subtract 0.1 from the Z1 box above	$.40 - .1 = .30$	Z4
Does Z2 lie in between the Z3 and Z4 number?	Yes	

*Table 10–2: Vertical Component Evaluation table*

**Obtaining Vertical Component (Z) for your location**

The first step will require navigating to the NOAA website and entering the geographical location of the aircraft. Enter the following link in your Internet browser:

<http://www.ngdc.noaa.gov/geomag-web/#igrfwmm>

Either enter your Zip code and click on “Get Location” or select a country and city from the drop down menus. Your known Lat/Long may also be entered. Once your closest geographical area is found the Lat/Long will pre-fill to the right. Leave the date fields as pre-filled (today’s date) and then click on “Compute Magnetic Field Values” near the bottom center of the screen. Under the column “Vertical Component” copy this value in nT (nanotesla) to the top box of Table 10-3.

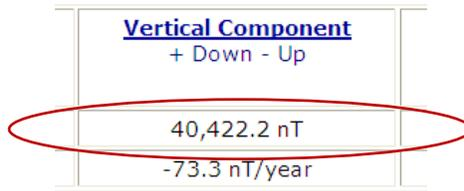
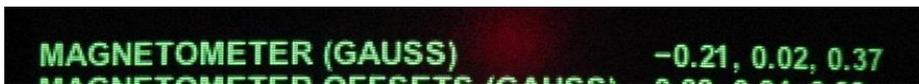

**Figure 10-8: nT Example**

This value must be converted by moving the decimal point over 5 places to the left. For example a value of 40,422.2nT will become .40 after the decimal is moved five places to the left and the 0.004222 is discarded. This value (Z1) will be compared to the Vertical Component on the EFD1000 E5 Diagnostic Page in the installation menu.

**Obtaining Vertical Component (Z) from EFD1000 E5**

Enter the EFD1000 E5 installation menu and navigate to the last menu page. On the Diagnostic Page locate the MAGNETOMETER (GAUSS) row and note the third value in the row. Copy this value to the Z2 box in Table 10-3 (example value is .37).



**Figure 10-9: EFD1000 Diagnostic Page Magnetometer Row Example**

If the pitch angle of the RSM to the horizon (with aircraft sitting on the landing gear) is less than 5 degrees then the “Z” value can be read directly and compared to the NOAA number above. If the RSM is tilted more than 5 degrees to the horizon then the averaging of two values to come up with a “Z” for comparison will be required. To average two readings the aircraft should be positioned facing north (±20 degrees) and a Z value recorded and then with the aircraft positioned exactly 180 degrees from the northern heading the Z value is recorded. Add these two numbers together and then divide by 2 to get the average “Z” value. Enter this value in the Z2 box of Table 10-3.

Now add and subtract 0.1 from Z1 to come up with a Z3 and Z4 range limit.

If Z2 falls between the Z3 and Z4 limits then the RSM location and magnetic signature is acceptable for your geographic location and a RSM Calibration can proceed.

If the Z2 value does not fall between the Z3 and Z4 range limits then further investigation is required. The RSM is not seeing the correct vertical component of the earth's magnetic field due to magnetic interference near the RSM. Check the RSM area for ferrous hardware and magnetic interference. Contact an Aspen Avionics Field Service Engineer if further troubleshooting is required.

If the RSM location is suspected of having magnetic interference a more accurate check is to level the RSM to the horizon and compare the actual Z (Z2) to the NOAA value. When level the RSM Z value should be within 0.03 of the NOAA value.

#### 10.5.1.2 Conventional Gear RSM Calibration Procedure

Perform the RSM calibration procedure per Section 10.5.2 with the tail wheel on the ground. Verify heading accuracy is within  $\pm 4^\circ$ . If the heading accuracy cannot be brought within  $\pm 4^\circ$  tolerance then try temporarily shimming the rear of the RSM up. Perform another RSM calibration. If a shim corrects the heading accuracy then install permanent shim per Section 6.9.12.

In some installations it might not be possible to achieve  $\pm 4^\circ$  accuracy during the RSM calibration with the aircraft tail wheel on the ground. If feasible and necessary, the RSM calibration can be performed in the aircraft flight attitude (with the aircraft tail wheel lifted off the ground). Contact Aspen Avionics product support for tail dragger RSM calibration assistance.

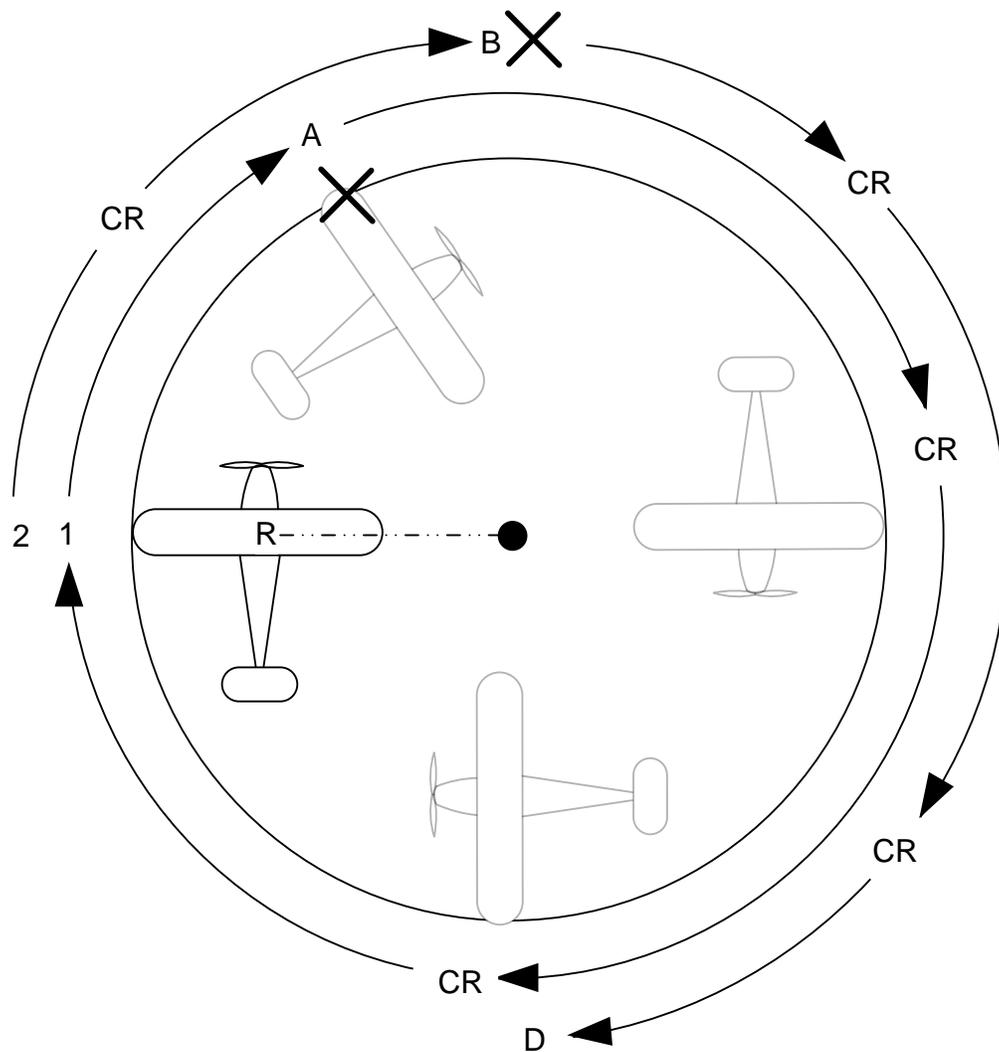

- = Imaginary pivot point
- R = Radius to pivot point – approximately equal to wingspan (≈30ft)
- 1 = Starting Point
- A = Established Constant Rate turn ≈ 10 seconds after 1
- CR = Constant Rate Turn must continue until end of 60sec timer
- 2 = 360° turn complete – continue at Constant Rate – Do not stop
- B = 60sec timer must not reach Zero before this point
- D = Accept/Reject CAL message occurs between B & D

**Figure 10-10: RSM Calibration Graphic**

### 10.5.2 RSM Calibration Procedure

The RSM calibration routine is accomplished using the Installation Menu “RSM CALIBRATION” menu page. See Section 10.4.5 (Installation Menu Access) for instructions on entering the INSTALLATION MENU.

***CAUTION:*** The “PANEL TILT PITCH ADJ” and “ROLL ATT TRIM” must be set correctly on the Installation Menu page prior to calibrating the RSM.



Figure 10–11: RSM Calibration Page

On the “RSM CALIBRATION” menu page the current calibrated heading (to the nearest 0.1 degrees) will be continuously displayed adjacent to the “CAL HDG:” menu field.

***NOTE:*** Verify CAL HDG is within 25 degrees of a calibrated compass source prior to starting the RSM Calibration. This is a rough check of the hard and soft iron effects (magnetic interference) in the vicinity of the RSM. Should the CAL HDG be greater than 25 degrees then the RSM location should be re-surveyed per Section 6.9.1.

With aircraft stationary at (POSITION 1) of Figure 10–10 press the “START CALIBRATION” line select key. The annunciation shown in Figure 10–12 will be displayed with a countdown timer that begins with 15 secs and counts down to 0 secs.

***CAUTION:*** Do not press ACCEPT Calibration without moving the aircraft in the procedure below as corruption to the configuration module could occur.

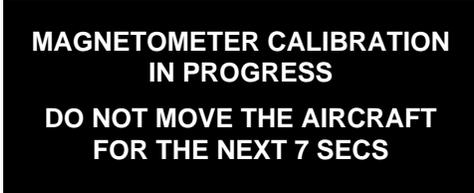

MAGNETOMETER CALIBRATION  
IN PROGRESS  
DO NOT MOVE THE AIRCRAFT  
FOR THE NEXT 7 SECS

*Figure 10-12: Calibration in Process*

When the menu of Figure 10-13 is displayed immediately begin taxiing the aircraft clockwise or counter-clockwise at a constant rate of no faster than 1 turn every 30 seconds. About half normal taxi speed or a brisk walking speed is about right. Approximately 10 seconds after initial movement (see **POSITION A**) the aircraft should be taxiing at a constant rate (**CR**) throughout the rest of the procedure. When the countdown timer is reached between one and a quarter turns (450°) (**POSITION B**) and two turns (720°) (**POSITION D**) should have been completed. While turning the aircraft do not stop the aircraft until the end of the 60-second timer and Figure 10-14 appears.

If you find that the timing of the turns was not right such that “Magnetometer Calibration Complete” message occurs between **B & D** of Figure 10-10, then **REJECT** the results and re-run the procedure.

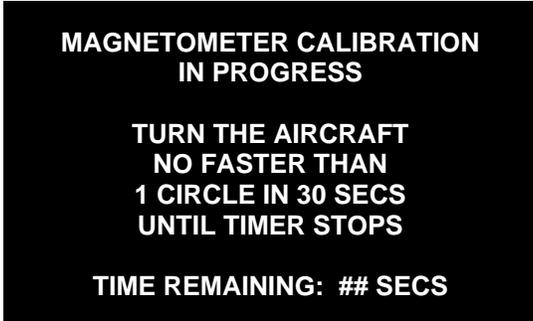

MAGNETOMETER CALIBRATION  
IN PROGRESS  
TURN THE AIRCRAFT  
NO FASTER THAN  
1 CIRCLE IN 30 SECS  
UNTIL TIMER STOPS  
TIME REMAINING: ## SECS

*Figure 10-13: Aircraft Turning*

At the end of the calibration routine the “ACCEPT CALIBRATION?” and “REJECT CALIBRATION?” menu options will be enabled.

**NOTE:** *If the message “Erroneous Calibration Values” is displayed then magnetic interference exists in the vicinity of the calibration area or the RSM is mounted in a magnetically noisy area. Try the calibration process again in a flat magnetically quiet area. If the message is displayed again the RSM location must be surveyed for magnetic interference.*



MAGNETOMETER CALIBRATION  
COMPLETE  
PLEASE ACCEPT OR REJECT RESULTS

*Figure 10-14: Accept/Reject Results*

To determine whether to **ACCEPT** or **REJECT** the results check four headings approximately 90° apart against a known good heading source (i.e., aircraft compass, sight compass, compass rose).

If the headings are within  $\pm 10^\circ$  then press ACCEPT and use the Heading Offset Adjustment in Section 10.5.3 to align each heading value to actual.

**NOTE:** Typically with a clean RSM location the heading values will be within 3 degrees of actual heading. If they are outside this value the RSM mounting area should be rechecked for magnetic contamination (internal interference) or the calibration can be rerun in a new location (external interference) to see if the values are improved. RSMs tilted to the upper end of the limit may not be able to achieve the 3 degree or less of error without using the Heading Offset Adjustment).

Pressing the “ACCEPT CALIBRATION” selection shall accept the calibration results, display the annunciation shown in Figure 10–15 for 5 seconds, and return the “RSM CALIBRATION” menu page to its initial state.

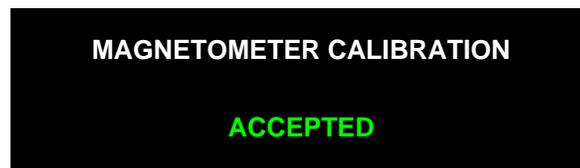

Figure 10–15: Results Accepted

Pressing the “REJECT CALIBRATION” selection shall reject the calibration results. Reject the results if the calibration was poor or a previously stored calibration has better heading accuracies.

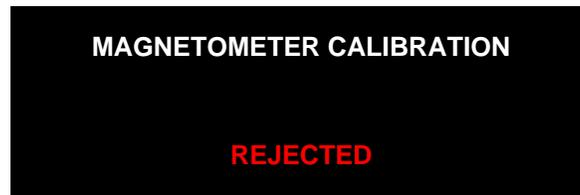

Figure 10–16: Results Rejected

### 10.5.3 Heading Offset Adjustment

#### 10.5.3.1 Heading Offset Adjustment

When the calibration routine is complete and the results have been accepted the CAL HDG value will be displayed.

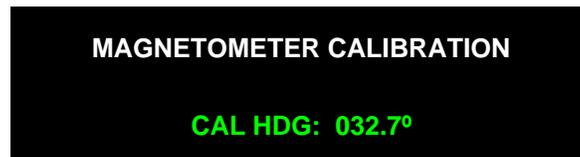
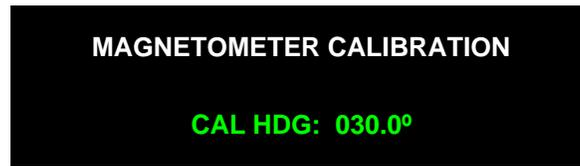

Figure 10–17: Calibration Heading Before Adjustment

Position the aircraft so that it is at a heading of  $30^\circ$  as verified by a sight compass or other calibrated means. Press the line select key next to “HDG SEL” and then turn the right knob until HDG SEL:  $030^\circ$  is displayed. Now press the line select key next to “HDG ADJ” and turn the right knob until the CAL HDG of Figure 10–17 displays exactly  $030.0^\circ$  as shown in Figure 10–18 or as close to  $030^\circ$  as possible within a  $\pm 4^\circ$  tolerance. The

HDG ADJ field will display the amount of correction (+/- 6.0 degrees) that was required. Press the HDG ADJ line select key to accept the setting.



*Figure 10–18: Calibrated Heading After Adjustment*

Now repeat the process above for all other headings in 30° increments from 60° to 360°. Press the MENU key to exit the Installation Menu. Continue with heading accuracy tests in Section 10.5.4.

**NOTE:** *In some aircraft, prop wash and wind during ground operations can create inconsistent pressures in the pitot–static system. The pressures can affect the ADAHRS, resulting in small pitch and heading perturbations. Before reading the aircraft headings for the purposes of calibration, ensure the attitude solution has stabilized and is not influenced by external winds and pressures. The disturbances normally settle out over a period of 15 to 60 seconds. Idle power or temporarily selecting the alternate static source can sometimes eliminate the effect.*

#### 10.5.4 Heading Accuracy Test

As a final check, position the aircraft on the headings shown on “Installation Final Check Sheet” of Appendix B and verify heading (viewed on compass card) is within +/- 4 degrees using a calibrated heading source (i.e., sight compass, compass rose). Record the actual EFD headings in the table for inclusion in the aircraft maintenance records.

If any heading is outside  $\pm 4^\circ$  then rerun the Calibration Procedure and or Heading Offset adjustment.

#### 10.5.5 Heading Interference Test

With aircraft engine(s) running monitor current aircraft heading on EFD and exercise flight controls stop to stop including flaps and any electric trim tabs. Verify the heading (viewed on compass card) does not change on the EFD by more than 2°. If movement of flight controls causes more than a 2° heading change then it may be necessary to degauss the flight controls including the cables. A handheld degausser can be found at most audio and video stores.

- Operate all electrical and environmental equipment including:
- Blowers, fans, heaters, air conditioner
- Deice boots, fuel pump(s), backup vacuum pumps
- Landing, logo, NAV lighting
- Operate pulse equipment – transponder, WX radar, DME
- Key all VHF communication radios.
- Operate autopilot so that all servos run (roll, pitch, yaw, trim)

If the operation of any electrical system causes the heading to change by more than 2° the RSM wiring may need to be relocated away from the offending system. The

offending system may also have a bonding issue to the airframe that needs to be corrected.

Run engine(s) from idle to take off power and verify that the heading does not change by more than 2°. Prop wash at higher engine RPMs may cause a heading shift; try an alternate static source if this is an issue.

This completes all RSM calibration and heading tests.

## 10.6 Ground Test Procedure

The ground test procedure will consist of checking for proper operation of the following items:

- Airspeed Tape and Altitude Tape
- AHRS Sensor
- GPS Sensor Inputs
- Navigation Sensor Inputs (if installed)
- Backup Navigation Indicator
- Autopilot Sensor Outputs (if installed)
- Ancillary Equipment Heading Check (if using heading output from EFD or ACU)
- Ancillary Equipment Air Data Check (if connected)
- EMI Test
- Flight Control Interference Check
- OBS Test

***CAUTION:*** Do not exceed the aircraft's maximum Airspeed, Altitude, or Vertical Speed at anytime during the testing. Damage could result to the pre-existing aircraft instruments.

***NOTE:*** When changing indicated airspeed or altitude on the ground using pitot/static test equipment, changes in the AHRS display of pitch, roll and heading will result, possibly accompanied by a CROSS CHECK ATTITUDE annunciation. This behavior is the result of the Kalman Filter algorithms employed in the EFD1000 attitude solution. These changes in pitch, roll or heading are normal and do NOT indicate a system failure. The integrated nature of the EFD1000 AHRS algorithms is such that AHRS performance can only be properly evaluated during flight or ground maneuvers.

### 10.6.1 Indicated Airspeed Display

***WARNING:*** This test must be accomplished by an appropriately rated mechanic or repairman (14 CFR 43.3).

Use the Installation Final Check Sheet of Appendix B to record the aircraft speed settings from the Aircraft Flight Manual in the IAS Setting column. Set the Pitot/Static test set for 5000 ft. above field elevation. Increase airspeed to Vne and check all Speed Bands and Speed Markers listed in table.

### 10.6.2 Altitude Display

With the Pitot/Static tester still set for 5000 ft. above field elevation and with BARO Set to 29.92 in. Hg. on the EFD (see Section 12), verify altitude tape displays altitude within  $\pm 40$ ft of the calibrated test set altitude.

### 10.6.3 System Leak Test

Perform a pitot-static system leak test per the aircraft manufacturer's maintenance manual or set the Pitot Static Test Set to 1000ft above field elevation and without additional pumping for a period of 1 minute the aircraft static system should not lose more than 100ft of altitude in a non-pressurized aircraft.

### 10.6.4 AHRS Sensor Test

Verify that correct aircraft attitude information is presented on the Attitude Indicator portion of the EFD. The Flags may take up to 5 minutes to clear when the ambient temperature is below  $-20^{\circ}$  C. Typically the attitude solution will be available in less than 3 minutes.

### 10.6.5 GPS1 Sensor Test (labeled as GPS1)

Refer to GPS manufacturer's instructions for operating GPS receiver and verifying a complete and fully functional interface.

#### 10.6.5.1 All GPS interfaces

- 1) Allow the GPS1 receiver to acquire a valid position and enter a Direct To waypoint or a Flight Plan.
- 2) Verify GPS groundspeed is displayed on the EFD. GPS1 unit may need to be in test mode. If GPS does not display groundspeed in test mode then verify the GPS groundspeed is displayed during a taxi test.
- 3) Select GPS1 on the EFD and verify the CRS pointer auto-slews (if enabled) to the desired track (DTK). To enable AUTOCRS go to Main Menu page 1.
- 4) Select OBS or Hold Mode (if available) on the GPS and verify that the CRS knob on the E5 has control over the CRS pointer (manual-slew).
- 5) Verify the To/From and Left/Right deflection has the correct polarity.

**NOTE:** The EFD1000 E5 displays the CDI in EFIS scale factors which are 2.5 dots full scale deflection. This is half that shown on a mechanical indicator. Therefore  $0.155DDM = 2.5$  dots and  $0.093DDM = 1.5$  dots on the EFD indicator.

**NOTE:** The EFD1000 E5 system will not display a VDI (GPS LPV Glide Slope) indicator without an activated valid LPV approach with APPROACH mode active.

- 6) Verify that the OBS resolver output (if available) reads correctly on the GPS.
- 7) Turn off the GPS1 receiver and verify GPS1 is red slashed and goes invalid on EFD.

#### 10.6.5.2 Analog GPS interfaces

Verify OBS accuracy on GPS1 and calibrate if necessary using GPS manufacturer's instructions.

**NOTE:** *The self-test page on these types of GPS may not pull the lateral flag and therefore may not show a valid CDI or to/from indication when in test mode.*

#### 10.6.6 NAV Receiver Sensor Test (label as VLOC1)

- 1) Select VLOC1 on the EFD and create a valid and invalid condition with a Nav Signal Generator verifying that the NAV Flag is displayed (Red Slash) when invalid.
- 2) Tune an ILS frequency on the Nav Receiver and verify the LDI (Localizer) scale is displayed on the ADI portion of the EFD.
- 3) Tune the Nav Signal Generator to the ILS test frequency and generate a valid Glide Slope signal. Verify the VDI (Glide Slope) scale appears on the right side of the ADI.
- 4) Generate a signal above and below the Glide Slope beam and verify proper polarity of the GS deviation for Fly Up and Fly Down on the EFD.

**NOTE:** *The EFD1000 E5 system will not display a VDI (Glide Slope) indicator without both valid localizer and Glide Slope signals*

#### 10.6.7 Backup Navigation Indicator

Verify the backup navigation indicator continues to function after pulling the EFD and ACU circuit breakers.

#### 10.6.8 Autopilot Sensor Test

Refer to autopilot manufacturer's post installation check out procedures for complete autopilot post installation ground checks. At a minimum complete the following checks to verify the EFD1000 E5 interface is satisfactory.

**NOTE:** *For attitude-based autopilots it might be necessary to level the autopilot gyro to get proper FD and autopilot response from the test.*

**CAUTION:** *Verify control surfaces are free and clear.*

- 1) If installed, center the HDG Bug under the lubber line and engage the autopilot and select HDG Mode.
- 2) The yoke should not turn.
- 3) Move the HDG Bug left of the lubber line and the yoke should bank left.
- 4) Move the HDG Bug to right of lubber line and the yoke should bank right.
- 5) With NAV1 selected on the EFD and a valid Nav Signal generated engage the autopilot in NAV Mode and verify that the yoke follows the CRS Pointer in phasing.
- 6) Verify that the autopilot responds to correct Left/Right phasing by generating left and right needle deflection. For autopilots that monitor the NAV FLAG, generate an invalid Nav Signal and verify autopilot responds accordingly.
- 7) Engage APPR Mode and verify that the autopilot responds correctly to a generated Fly Up and Fly Down command. For autopilots that monitor the GS FLAG, generate an invalid GS Signal and verify autopilot responds accordingly.

### 10.6.9 Ancillary Equipment Heading Check

- 1) Verify proper operation of any ancillary components that are using either the ARINC 429, RS-232 or the ARINC 407 synchro heading output.
- 2) Use ancillary equipment manufacturers' installation test procedures to perform ground check on their equipment.

### 10.6.10 Ancillary Equipment Air Data Check

- 1) Verify proper operation of any ancillary components that are using the ARINC 429 or RS-232 air data output from the EFD1000 E5 system.
- 2) Use ancillary equipment manufacturers' installation test procedures to perform ground checks on their equipment.

### 10.6.11 Internal battery tests

All EFD1000 E5 systems have an internal battery that must be tested.

For best results, read these instructions before executing the test.

- 1) Provide external power to the EFD1000 E5.
- 2) Select the battery menu by pressing the MENU key and rotating the right knob to the second to the last page. This is the page that shows the battery and external power conditions. Verify that the external power voltage (the power to the EFD) is at the appropriate level for the aircraft, and the last line on the Menu page shows BATT: CHARGING.
- 3) With the EFD Menu displayed, press the line select key on the EFD menu next to "BATTERY". A timer will count down, after which the battery percentage remaining will be displayed. Power for the EFD will transition from external power to EFD battery power.
- 4) NOTE: The external power to the EFD must continue to be supplied.
- 5) Verify that the battery percentage remaining is at least 80%. See the note below.
- 6) This completes the test.

***NOTE: If the battery remaining percentage is below 80%, then charge the internal battery to 80% or above by leaving the EFD powered on from external power using a suitable Ground Power Unit.***

### 10.6.12 TAPES Configuration Check

Verify the tapes are "LOCKED" or "UNLOCKED" as required.

- If TAPES are locked on (LOCK ON) – IAS and Altitude tapes should be visible and when pressing the MENU key the TPS line select key should be locked to ENABLE.
- If TAPES are locked off (LOCK OFF) – IAS and Altitude tapes should not be displayed on EFD and when pressing the MENU key the TPS line select key should be locked to DISABLE.
- If TAPES are UNLOCKED – then pressing the MENU key and then the TPS line select key will allow setting to be changed from ENABLE to DISABLE.

**10.6.13 EMI Test**

Perform the EMI tests in this section with the EFD1000 E5 System (with associated operating peripheral equipment, RSM, ACU and EA100) and the autopilot engaged in any mode. In the tests below, the “Threat Equipment” is the EFD1000 E5 system.

**EFD1000 E5 System as the EMI Victim:**

Monitor the EFD1000 E5 System for any indication of interference. Monitor the EFD for Flags, Red-X’s, Red Slashes, heading changes, altitude changes, airspeed changes, attitude changes or any error messages while performing the following tests. Assure that the EA100 A/P AHRS lamp remains extinguished and there is no uncommanded autopilot-disconnect while performing the following tests:

- 1) Operate engine(s) and verify no interference.
- 2) Transmit on all Comm radios for 20 seconds each at 118.000MHz, 126.900MHz, and 136.950MHz.
- 3) Turn on all transponders, DMEs, Weather Radar, and all other pulse-type equipment for 20 seconds each.
- 4) Operate all aircraft lighting including position lights, strobe lights, navigation lights, and all other forms of lighting for 20 seconds each.
- 5) Operate all environmental equipment including fans, air conditioning, heaters, and all other forms of environmental control equipment for 20 seconds each.
- 6) Operate fuel pump(s), deice boots, windshield heat, prop heat, flaps.
- 7) Operate autopilot servos, yaw damper, and all electric trim servos.

**EFD1000 E5 System as the EMI Source:**

SYSTEM DESCRIPTION	POSITION	EFD1000 E5 System	
		Pass	Fail
Tests are to be conducted with the aircraft operating with engine(s) running			
<b>COMMUNICATIONS</b>			
<b>VHF COMMUNICATIONS</b>			
Check field or local frequencies (ATIS, local ground, tower, etc.) to listen to the quality of the received signals from those systems. Record local or field frequencies used. Listen for objectionable audio noise. If noise is present shut down the EFD1000 E5 System to determine if it is inducing the noise. Testing should also be accomplished on 118.00hz, 126.900MHz, 136.950MHz, 120.00 MHz and 125.00 MHz.	No 1		
	No 2		
<b>COCKPIT INTERCOM</b>			
Initiate several conversations between crew positions and verify interference free communications while monitoring the effects of the Threat equipment.			

SYSTEM DESCRIPTION	POSITION	EFD1000 E5 System	
		Pass	Fail
Using the cockpit intercom, verify interference free communications between the crew while monitoring the effects of the Threat equipment.			
<b>NAVIGATION</b>			
<b>VOR / ILS</b>			
Verify the operation of each VHF Nav receiver in both VOR and ILS modes (including glideslope) while monitoring the effects of the Threat equipment. At a minimum, use of ground test equipment is required. Use of ground stations should be accomplished if facilities are available. Record the frequencies tested.	No 1		
	No 2		
<b>DME (If Installed)</b>			
Verify the operation of each DME while monitoring the effects of the Threat equipment. Ground test equipment or the same local frequencies used for VOR and ILS testing may be used for this test.	No 1		
	No 2		
<b>MARKER BEACON</b>			
Verify the operation of each Marker Beacon Receiver while monitoring the effects of the Threat equipment.	No 1		
	No 2		
<b>ADF (If Installed)</b>			
Verify the operation of each ADF receiver while monitoring the effects of the Threat equipment. Frequencies from each band should be tested where possible. Public broadcast stations are acceptable for conducting test.			
<b>GPS</b>			
Verify the operation of each GPS receiver while monitoring the effects of the Threat equipment. GPS satellite signals should be stable and of similar strength with the threat equipment on and off. The navigation systems used to display GPS information should not have any interference effects from the threat equipment. Record GPS satellite and position data for each system.	No 1		
	No 2		
<b>FLIGHT CONTROL SYSTEMS AND DISPLAYS</b>			
<b>DISPLAY</b>			
Verify the EFD1000 E5 display functions without interference while monitoring the effects of the peripheral Threat equipment.			
<b>FLIGHT DIRECTOR (If Installed)</b>			
Operate the flight director system and verify it responds to commands from the control panel while monitoring the effects of the Threat equipment.			

SYSTEM DESCRIPTION	POSITION	EFD1000 E5 System	
		Pass	Fail
<b>AIR DATA</b>			
Verify the EFD1000 E5 altimeter is presenting correct and steady information while monitoring the effects of the peripheral Threat Equipment.			
<b>AUTOPILOT (If Installed)</b>			
Verify the autopilot operates correctly while monitoring the effects of the Threat Equipment. Sufficient testing should be accomplished to provide confidence in system operation. If this level of testing is not possible, the autopilot should not be engaged in flight until a safe altitude has been achieved.			
<b>COMPASS SYSTEM</b>			
Verify the EFD1000 E5 compass system is presenting correct information while monitoring the effects of the peripheral Threat equipment.			
<b>ATTITUDE SYSTEM</b>			
Verify the EFD1000 E5 attitude system is presenting correct information while monitoring the effects of the peripheral Threat equipment.			
<b>SAFETY EQUIPMENT</b>			
<b>WEATHER RADAR (If Installed)</b>			
Verify the function of the weather radar system while monitoring the effects of the Threat equipment. Prior to ground operation of the radar, proper safety precautions need to be observed to prevent injury or damage to ground personnel or equipment.			
<b>RADIO ALTIMETER (If Installed)</b>			
Verify the radio altimeter system functions correctly while monitoring the effects of the Threat equipment. The radio altimeter should self test correctly and be free of continuous variation while parked on the ramp.			
<b>ENGINE INDICATING AND FUEL QUANTITY</b>			
Start the aircraft engine(s) and configure the aircraft for normal in-flight operations (i.e. pitot heat, lights, etc.) Verify the engine instruments display correct and stable information while monitoring the effects of the Threat Equipment. This may be accomplished immediately prior to flight-testing if practicable.	ENGINE		
	FUEL QTY		
<b>CONTROL SURFACE POSITION INDICATIONS</b>			
Verify operation of flaps and electric trim while monitoring the effects of the threat equipment. Surfaces should move smoothly through the entire range of operation without interference.	FLAPS		
	ELEC TRIM		

SYSTEM DESCRIPTION	POSITION	EFD1000 E5 System	
		Pass	Fail
OTHER EQUIPMENT (specify)			
<b>Traffic Avoidance Systems (TCAS, TAS, TIS, TCAD)</b> Verify that the equipment functions properly without interference while monitoring the effects of the Threat equipment.			
<b>TAWS/GPWS (If Installed)</b> Verify that the equipment functions properly without interference while monitoring the effects of the Threat equipment.			
<b>Other Avionics (Specify)</b> Verify that the equipment functions properly without interference while monitoring the effects of the Threat equipment.			

**10.6.14 Flight Control Interference Check**

***CAUTION: Verify control surfaces are free and clear.***

With the EFD mounted in the instrument panel push the control column (yoke or stick) all the way forward (nose down) and verify there is sufficient clearance between all EFD, and their knobs, and the control column. With the control column fully forward move it from lock to lock (full right to full left) and verify there is sufficient clearance between the EFD, and the knobs, and the control column.

**10.6.15 OBS Mode Check**

- 1) Establish a flight plan on the GPS device with a destination within 200 miles.
- 2) Enable the OBS mode on the GPS devices.
- 3) Select GPS 1 on the EFD and select CRS on the EFD
- 4) Turn the CRS knob.
- 5) The GPS 1 OBS should respond to the CRS value.

### 10.6.16 EA100 Adapter Testing

See Appendix E for EA100 Adapter configuration and testing.

## 11 Post Installation Flight Check

***CAUTION:*** Only perform the Operational Check in day VFR conditions with an appropriately rated pilot for the aircraft type to be flown.

If the EA100 is installed see Appendix E for additional checks

### 11.1 Attitude Display Flight Checks

Fly the aircraft in straight and level flight and verify that the ADI roll indication is level with reference to the horizon. Observe the Slip Indicator is centered under the Roll pointer and adjust rudder trim if available to center.

- a) Make a coordinated 30-degree banked turn to the right and verify that the ADI roll indication is correct with reference to the horizon.
- b) Make a coordinated 30-degree banked turn to the left and verify the ADI roll indication is correct with reference to the horizon.
- c) Pitch the aircraft up 10 degrees and verify the ADI pitch indication is correct with reference to the horizon.
- d) Pitch the aircraft down 10 degrees and verify the ADI pitch indication is correct with reference to the horizon.

### 11.2 Heading Card Flight Checks

- a) Make a 180-degree coordinated turn to the right and verify that the compass scale and numerical heading indication correctly track the aircraft heading during the turn.
- b) Make a 180-degree coordinated turn to the left and verify that the compass scale and numerical heading indication correctly track the aircraft heading during the turn.
- c) Then turn from West to North (30° Angle of Bank) and, using an outside reference, roll out to a northerly heading. (In the Southern Hemisphere, also turn West to South)
- d) Immediately after the aircraft rolls out, record the heading indication.
- e) Maintain the same heading by outside visual reference. There may be some movement of the heading indicator as the heading system stabilizes.
- f) When the heading stabilizes, record the heading again. Then perform the test from East to North (In the southern Hemisphere, also turn east to South).
- g) If the difference between the heading on rollout and the heading after stabilizing is more than 7°, refer to the Troubleshooting Guide, Appendix A.

### 11.3 ILS Flight Checks

- a) If configured, hand fly an ILS approach and verify that the raw data on the E5 for Lateral and Vertical Deviation Indicators are correctly displayed. Check the CDI indication for correct needle displacement.

## 11.4 Autopilot Flight Checks (if installed)

***WARNING:*** Remember to disconnect the Autopilot immediately if it is not performing its intended function.

With wings level and the HDG Bug centered under the lubber line, deselect GPSS and engage the autopilot in HDG Mode and ALT Hold Mode (if available). Verify that the aircraft makes no abrupt turns during engagement and the aircraft continues to track straight.

- a) Now turn the HDG Bug 10 degrees to the right and verify the aircraft smoothly turns to the right with a bank angle not exceeding 10 degrees. If 10 degrees was acceptable in performance then proceed by turning the HDG Bug 90 degrees to the right and verify the aircraft makes a standard rate turn and smoothly rolls out on to the correct Heading.
- b) Now repeat the test to the left.
- c) With VLOC1 selected (VOR1 source indication) and a VOR Station tuned. Adjust the CRS pointer to center the CDI. Engage the autopilot in NAV Mode and verify the aircraft tracks to the VOR.
- d) Enter a valid flight plan or Direct To on the GPS. Couple the GPS to the E5. Engage the autopilot in NAV Mode, verify the autopilot tracks the GPS. (Note: GPSS is disabled for this test, this test is verifying the GPS deviations to the autopilot)
- e) For GPS receivers using ARINC 429 interfaces, enable GPSS and engage the autopilot in HDG Mode. Verify the autopilot tracks the GPS flight plan. Place the GPS into OBS (HOLD) Mode (some GPS installations may require manual disabling of AUTO CRS). Use the CRS Pointer on the E5 to steer the autopilot via the GPS. With the HDG Bug centered, press the GPSS button again and verify the HDG Bug controls the autopilot as before.
- f) Perform an ILS approach using VLOC1 (ILS1 source indication). Verify that the autopilot tracks the localizer, then captures and tracks the glideslope if installed.
- g) If your GPS supports GPS WAAS LPV approaches, perform an LPV approach using GPS1. Verify that the autopilot tracks the GPS lateral approach guidance, then captures and tracks the GPS LPV vertical guidance.

## 11.5 Document Operational Check

This completes the Operational Check. If everything was satisfactory then document the completion of the Operational Check in aircraft logbook in accordance with FAR 91.407(b).

## 12 Operating Instructions

Basic operation of EFD1000 E5 is covered in this section. For detailed operating instructions see the E5 pilot's guide.

### 12.1 Pilot Controls

#### 12.1.1 Overview

Pilot interaction with the EFD1000 E5 is accomplished through two knobs with push/rotate function and 11 buttons located on the display bezel.

Two control knobs are used to control pilot settable bugs and references.

The center lower push button, located between the control knobs, is used to select navigation sources.

Three dedicated buttons on the upper side of the right bezel provides access to the main menu.

Five soft keys on the lower half of the right bezel control frequently used commands. The soft keys are also used when navigating the main menu and for enabling the right knob for barometric pressure and VSI bug (when configured).

#### 12.1.2 Power Control

To enhance safety, the EFD1000 E5 includes an internal battery that allows the system to continue to operate in the event of a failure of the aircraft electrical system.

The typical EFD1000 E5 installation receives aircraft power from the battery bus via a dedicated circuit breaker and EFD1000 E5 Master switch.

Whenever indicated airspeed is invalid or below 30 KIAS the EFD1000 E5 will power up and power down with the application or removal of external power. A message is presented during the normal power down sequence to enable the pilot to abort the shutdown and switch to internal battery.

When IAS is greater than 30 KIAS and the input voltage drops below 12.3V (14V Electrical System) or 24.6V (28V Electrical System) the EFD will automatically switch to its internal battery (e.g. aircraft charging system failure).

The EFD will also switch to internal battery if an overvoltage condition is sensed.

The EFD internal battery provides power to the display head and RSM. Reducing the backlight intensity will extend the battery operating time.

When operating from battery, a red "ON BAT" annunciation and battery charge status indication is presented in the lower portion of the Attitude Indicator.

A unit operating from battery may be powered off using the "Shut Down" command available in the Power Settings Menu.

In the unlikely event that the normal power control is not working, the EFD may be forced to shut down by first pulling its associated circuit breaker and then pressing and holding the REV button for at least 5 seconds.

Battery charge status may be viewed from the “Power Settings” page of the Main Menu.

### 13 Environmental Qualification Forms

**Nomenclature:**..... EFD1000 E5 Evolution Flight Display with Configuration Module

**Part Number:**..... 910-00101-001 and CM: 910-00005-004

**Manufacturer:**..... Aspen Avionics, Inc.

**Address:**..... 5001 Indian School Road NE, Albuquerque, NM 87110

**DO-160 Revision:**..... DO-160E (DO-160G for Section 20 Category R)

**Date Tested:**..... 2/2008 and 10/2018

CONDITIONS	SECTION	DESCRIPTION OF TESTS CONDUCTED
Temperature and Altitude (Pressurized)	4.0	Equipment tested to Category A1, Decompress to 55,000", Controlled temp and pressurized to <15,000'
Temperature and Altitude (Unpressurized)	4.0	Equipment tested to Category C1, Controlled temp and non-pressurized to 35,000'
Loss of Cooling	4.5.5	Equipment tested to Category Y, 300 minutes min.
Temperature Variation	5.0	Equipment tested to Category C
Humidity	6.0	Equipment tested to Category A, standard humidity environment
Operational Shock and Crash Safety	7.0	Equipment tested to Category B, standard operational shock and crash safety
Vibration (Fixed Wing)	8.0	Equipment tested to Category S, aircraft Zone 2 for Fixed Wing Reciprocating & Turboprop Engines, Multi Eng over 5700 KG (12,500 lbs), Multi Eng Less than 5700 KG (12,500 lbs), and Single Eng Less than 5700 KG (12,500 lbs) using vibration test curve M.
Explosive Atmosphere	9.0	Equipment identified as Category X, no test performed
Waterproofness	10.0	Equipment identified as Category X, no test performed
Fluids Susceptibility	11.0	Equipment identified as Category X, no test performed
Sand and Dust	12.0	Equipment identified as Category X, no test performed
Fungus	13.0	Equipment identified as Category X, no test performed
Salt Fog Test	14.0	Equipment identified as Category X, no test performed
Magnetic Effect	15.0	Equipment tested to Category Z, causes < 0.5 deg deflection to compass 0.3 meter away
Power Input	16.0	Equipment tested to Category B
Voltage Spike	17.0	Equipment tested to Category A
Audio Freq Conducted Susceptibility	18.0	Equipment tested to Category B
Induced Signal Susceptibility	19.0	Equipment tested to Category ZC
RF Susceptibility	20.0	Equipment tested in Accordance With PS-ACE-23-10
Additional Radio Frequency Susceptibility (Conducted)	20.4	In addition, Conducted susceptibility per the Generic Conductive Curve- <25 meters extrapolated the Env I per the applicable levels defined in RTCA/DO-160E section 20, category A. Per FAA Policy PS-ACE-23-10
Additional Radio Frequency Susceptibility (Radiated)	20.5	In addition, Radiated Susceptibility per Aircraft Generic Attenuation Curves applied to Env I. 0 dB: 100 MHz - 400 MHz -6 dB: 400 MHz - 1 GHz -12 dB: 1 GHz - 18 GHz In accordance with FAA Policy PS-ACE-23-10.
RF Emissions	21.0	Equipment tested to Category M, significant EM apertures, not in direct view of radio receiver antenna (Equipment mounted in cockpit or cabin area)
Lighting Induced Transient	22.0	A3J33 and B3K33 for Refresh EFD1000 power pins, Refresh EFD1000 power bundle, RSM pins, and RSM bundles, in accordance with FAA Policy PS-ACE-23-10.  A2J22 and B2K22 for all other Refresh EFD1000 pins and cables. Note: the main bundle was tested at level 2 and level 3.
Lightning Direct Effects	23.0	Equipment identified as Category X, no test performed
Icing	24.0	Equipment identified as Category X, no test performed
ESD	25.0	Equipment tested to Category A
Fire, Flammability	26.0	Equipment identified as Category X, no test performed
Other Tests		Fire resistance was conducted by analysis in accordance with Federal Aviation Regulations Part 25, Appendix F.

**Table 13-1: EFD1000 E5 Environmental Qualification Form**

**Nomenclature:**..... EFD1000 Remote Sensor Module (RSM)  
**Part Number:**..... 910-00003-001, 910-00003-002, 910-00003-003  
**TSO Numbers:** ..... TSO-C113  
**Manufacturer:**..... Aspen Avionics, Inc.  
**Address:**..... 5001 Indian School Road NE, Albuquerque, NM 87110  
**DO-160 Revision:**..... DO-160E  
**Date Tested:**..... 2/2008 and 10/2018

CONDITIONS	SECTION	DESCRIPTION OF TESTS CONDUCTED
Temperature and Altitude	4.0	Equipment tested to Category F2, non-controlled temp and non-pressurized to 55,000'
Temperature Variation	5.0	Equipment tested to Category A, external, non-temperature controlled - 10 deg. C/minute
Humidity	6.0	Equipment tested to Category C, external humidity environment
Operational Shocks	7.0	Equipment tested to Category A
Vibration	8.0	Equipment tested to Category S, aircraft Zone 1 for Fixed Wing Reciprocating & Turboprop Engines, Multi Eng Less than 5700 KG (12,500 lbs.) (Does not include structure directly affected by jet efflux), and Single Eng Less than 5700 KG (12,500 lbs.) using vibration test curve M.
Explosive Atmosphere	9.0	Equipment identified as Category X, no test performed
Waterproofness	10.0	Equipment tested to Category S
Fluid Susceptibility	11.0	Equipment tested to Category F, deicing fluids and aircraft cleaning compounds only
Sand and Dust	12.0	Equipment identified as Category X, no test performed
Fungus	13.0	Equipment identified as Category X, no test performed
Salt Fog Test	14.0	Equipment identified as Category X, no test performed
Magnetic Effect	15.0	Equipment tested to Category Z, causes < 0.5 deg deflection to compass 0.3 meter away
Power Input	16.0	n/a - Powered from EFD display
Voltage Spike	17.0	n/a - Powered from EFD display
Audio Freq Conducted Susceptibility	18.0	n/a - Powered from EFD display
Induced Signal Susceptibility	19.0	Equipment tested to Category ZC
RF Susceptibility	20.0	Equipment tested in Accordance With PS-ACE-23-10
Additional Radio Frequency Susceptibility (Conducted)	20.4	In addition, Conducted susceptibility per the Generic Conductive Curve- <25 meters extrapolated the Env I per the applicable levels defined in RTCA/DO-160E section 20, category A. Per FAA Policy PS-ACE-23-10
Additional Radio Frequency Susceptibility (Radiated)	20.5	In addition, Radiated Susceptibility per Aircraft Generic Attenuation Curves applied to Env I. 0 dB: 100 MHz - 400 MHz -6 dB: 400 MHz - 1 GHz -12 dB: 1 GHz - 18 GHz In accordance with FAA Policy PS-ACE-23-10.
RF Emissions	21.0	Equipment tested to Category H, direct view of radio receiver antenna. (equipment mounted outside airframe)
Lighting Induced Transient	22.0	A3J33 and B3K33 for Refresh EFD1000 power pins, Refresh EFD1000 power bundle, RSM pins, and RSM bundles, in accordance with FAA Policy PS-ACE-23-10.
Lightning Direct Effects	23.0	Equipment tested to Category 2A, mounted in area with sweptback attachment, but no hang on
Icing	24.0	Equipment tested to Category C, external environment
ESD	25.0	Equipment tested to Category A
Fire, Flammability	26.0	Equipment identified as Category X, no test performed
Other Tests		Fire resistance was conducted by analysis in accordance with Federal Aviation Regulations Part 25, Appendix F.
Note: RSM -002 and -003 Mod D, and -001 Mod F were tested to and found to meet the above specifications by test and by similarity analysis. The testing was conducted in February, 2015.		

**Table 13-2: RSM Environmental Qualification Form**

**Nomenclature:**..... Analog Converter Unit (ACU and ACU2)  
**Part Number:**..... 910-00004-001 and 910-00004-10x  
**TSO Numbers:** ..... TSO-C113  
**Manufacturer:**..... Aspen Avionics, Inc.  
**Address:**..... 5001 Indian School Road NE, Albuquerque, NM 87110  
**DO-160 Revision:**..... DO-160E  
**Date Tested:**..... 2/2008

CONDITIONS	SECTION	DESCRIPTION OF TESTS CONDUCTED
Temp/ Altitude (Pressurized)	4.0	Equipment tested to Category C4, controlled temp and pressurized to <15,000'
Temp/ Altitude	4.0	Equipment tested to Category A1, Operating low temperature -40C, Operating High +55C, Short Time Operating Low -40C, Short-Time Operating High +70C, Loss of Cooling, N/A, Ground Survival Low -55C, Ground Survival High +85C and non-pressurized to 35,000'
Temperature Variation	5.0	Equipment tested to Category C, internal, temperature controlled - 2 deg. C/minute
Humidity	6.0	Equipment tested to Category A
Operational Shocks and Crash Safety	7.0	Equipment tested to Category B
Vibration (Fixed Wing)	8.0	Equipment tested to Category S, aircraft Zone 2 for Fixed Wing Reciprocating & Turboprop Engines, Multi Eng over 5700 KG (12,500 lbs.), Multi Eng Less than 5700 KG (12,500 lbs.), and Single Eng Less than 5700 KG (12,500 lbs.) using vibration test curve M.
Explosive Atmosphere	9.0	Equipment identified as Category X, no test performed
Waterproofness	10.0	Equipment identified as Category X, no test performed
Fluids Susceptibility	11.0	Equipment identified as Category X, no test performed
Sand and Dust	12.0	Equipment identified as Category X, no test performed
Fungus	13.0	Equipment identified as Category X, no test performed
Salt Fog Test	14.0	Equipment identified as Category X, no test performed
Magnetic Effect	15.0	Equipment tested to Category Z , causes < 1.0 deg deflection to compass 0.3 meter away
Power Input	16.0	Equipment tested to Category B
Voltage Spike	17.0	Equipment tested to Category A
Audio Freq Conducted Susceptibility	18.0	Equipment tested to Category B
Induced Signal Susceptibility	19.0	Equipment tested to Category ZC
RF Susceptibility	20.0	Equipment tested to Category WW, (Conducted/Radiated) Bench test to show compliance with interim HIRF rules. 100V/m
RF Emissions	21.0	Equipment tested to Category M, significant EM apertures, not in direct view of radio receiver antenna (Equip mounted in cockpit or cabin area)
Lighting Induced Transient	22.0	Equipment tested to Category B3K33, moderately exposed all-metal airframes, airframes composed of metal framework and all composite skin panels or carbon fiber composite airframes whose major surface areas have been protected with metal meshes or foils
Lightning Direct Effects	23.0	Equipment identified as Category X, no test performed
Icing	24.0	Equipment identified as Category X, no test performed
ESD	25.0	Equipment tested to Category A
Fire, Flammability	26.0	Equipment identified as Category X, no test performed
Other Tests		Fire resistance was conducted by analysis in accordance with Federal Aviation Regulations Part 25, Appendix F.

**Table 13-3: ACU Environmental Qualification Form**

THIS PAGE IS INTENTIONALLY LEFT BLANK

## Appendix A : Troubleshooting

## System Troubleshooting

### Initialization Page

Test	Fault	Corrective Action
IOP	a) Fail	a) Replace EFD
	b) System reboots after IOP test	b) Replace EFD
ARINC	a) Fail	a) Replace EFD
RS-232	a) Fail	a) Replace EFD
Config Module	a) Fail	a) Check Config Module wiring. Replace Config Module.
	b) Wrong CM version	b) Install correct SW version CM.
	c) Displays "Initializing" for more than 20 seconds	c) Config Module unplugged or mis-wired.
RSM	a) Fail (x)	a) Check RSM to EFD wiring for shorts or opens. Repair or replace RSM. Repair or replace EFD.
IMU	a) Fail	a) Replace EFD
ADC	a) Fail	a) Replace EFD
ADAHRS	a) Fail	a) Replace EFD
	b) "Initializing" for more than 3 minutes	b) Remove Pitot and Static line from back of EFD and reboot. If problem still exists then replace the EFD. If problem clears then repair Pitot or Static obstruction/kink.
	c) "Initializing" for more than 3 minutes with a RSM Fail above.	c) Repair RSM wiring or replace RSM.

**NOTE**

It is possible to advance the system beyond a failed Initialization Screen by holding the MENU key and line select keys #1 and #2 simultaneously for 3-4 seconds. The Diagnostic screen may then be accessed in the installation menu for further troubleshooting.

System Troubleshooting –continued

Fault	Cause	Corrective Action
Display does not power on <i>(Note: there can be up to a 20 second delay from the application of power to a visible display)</i>	a) EFD missing A/C power	a) Check EFD circuit breaker, EFD on/off switch on panel, wiring, and A/C battery voltage > 11.5 volts.
	b) EFD may have been improperly shut down	b) Switch unit off using “REV” button or “SHUT DOWN” command from Main Menu page 6.
	c) EFD missing A/C ground	c) Check wiring to EFD
	d) EFD is defective	d) Repair or replace EFD
Display does not power off <i>(Note: EFD will switch to internal battery if airspeed is greater than 30kts.)</i>	a) Airspeed is above 30kts	a) Normal operation
	b) EFD may have been switched to internal battery	b) Switch unit off using “REV” button or “SHUT DOWN” command from Main Menu page 6.
	c) EFD may have been improperly shut down	c) Hold “REV” button for 20 seconds or unplug EFD internal battery for 3 seconds
	d) EFD is defective	d) Repair or replace EFD
Display flashes on/off, black/white or blue/white repetitively	a) Configuration Module unplugged or miss wired	a) Check CM plug and wiring from EFD to CM
	b) RSM or CM wiring short	b) Verify RSM pin 6 or CM pin 1 is not shorted to aircraft ground or another pin.
	c) Configuration module defective	c) Repair or replace CM
	d) EFD defective	d) Repair or replace EFD
ALTIMETER, AIRSPEED, VSI FAIL (RED-X)	a) Air data sensor has not had sufficient warm-up time.	a) Allow up to 20 minutes at temps below - 20°C for flags to clear
	b) Pitot/static lines reversed	b) Connect pitot line to “P” port and static line to “S” port on EFD
	c) Air data sensor failed	c) Repair or replace EFD
ATTITUDE FAIL or DIRECTION FAIL ( RED-X) <i>(Note: Attitude flags could take up to 3 minutes to clear at temps below - 20°C)</i>	a) AHRS sensor has not completed initialization.	a) Allow up to 3 minutes for AHRS to initialize.
	b) RSM failed/data missing.	b) Check RSM to EFD wiring. Repair or replace RSM.
	c) Pitot and/or Static lines crossed, unplugged, or blocked.	c) Correct pitot/static plumbing issue.
	d) EFD is defective	d) Repair or replace EFD.

Fault	Cause	Corrective Action
ATTITUDE DEGRADED message	a) In Flight, Normal if pitot blockage due to ice or other.	a) Use pitot heat or check pitot system for blockage.
	b) On Ground, Normal if GPS reception is marginal and GPS GS ramps above 50Kts intermittently.	b) No further action required unless message is due to faulty GPS system, then repair GPS system.
CROSS CHECK ATTITUDE message (yellow) (also see sluggish AHRS performance troubleshooting)	a) If it occurred on system start.	a) RESET AHRS
	b) Normal after abrupt maneuvers on ground or in air	b) RESET AHRS
Red Slash through Navigation Sensor (i.e., GPS1, NAV2)	a) GPS or VLOC receiver turned off.	a) Turn on GPS or VLOC receiver
	b) GPS does not have a valid "TO" waypoint and position	b) Allow GPS to acquire a position and enter a flight plan or Direct To
	c) GPS or VLOC receiver failed	c) See GPS/VLOC manufacturer's instructions for troubleshooting
	d) ACU not powered	d) Check ACU circuit breaker
	e) Wiring fault between sensor and ACU or EFD	e) Check wiring between GPS/VLOC and ACU or EFD
	f) ACU to EFD wiring fault.	f) Check ACU circuit breaker, check ACU to EFD A429 wiring and ACU to sensor wiring
	g) ACU is defective.	g) Repair or replace ACU
	h) EFD is defective.	h) Repair or replace EFD
GPS1 selection not available on Display (GNS430/GNS530/GNS480 only)	a) GPS receiver turned off	a) Turn on GPS and initialize
	b) GPS does not have a valid "TO" waypoint and position	b) Allow GPS to acquire a position and enter a flight plan or Direct To
	c) GNS CDI is selected to VLOC.	c) Verify the GNS CDI is selected to GPS.
	d) GPS to EFD A429 wiring issue.	d) Check A429 wiring for shorts, opens or crossed A and B lines.
	e) GPS defective.	e) Repair or replace GPS
	f) EFD defective.	f) Repair or replace EFD

Fault	Cause	Corrective Action
Autopilot or analog NAV/GPS inoperative	a) ACU chassis not grounded	a) Ground ACU chassis to airframe ground
	b) ACU not powered	b) Check ACU circuit breaker and power/grounds
	c) ACU to sensor wiring	c) Check ACU to sensor wiring
	d) ACU to EFD wiring	d) Check ACU to EFD A429 wiring
	e) ACU fault	e) Repair or replace ACU
	f) EFD fault	f) Repair or replace EFD
<p>“ERRONEOUS CALIBRATION VALUES” message during RSM Cal</p> <p>or</p> <p>Excessive Heading errors in one quadrant, or errors that are higher than actual in some quadrants and lower than actual in other quadrants.</p>	a) RSM is tilted more than allowed per Section 6 of this manual	a) Shim RSM to within limits defined in Section 6 of this manual
	b) Poor RSM calibration	b) Re-run RSM calibration at constant rate turns on flat ground.
	c) RSM calibrated too close to buildings or ferrous objects	c) Re-run RSM calibration away from buildings and other ferrous objects
	d) Ferrous hardware used to mount RSM	d) Only non-ferrous screws, nuts, washers may be used on RSM
	e) Airframe or external magnetic interference	e) Check for magnetized areas on airframe close to RSM. Verify no ferrous hardware is near RSM. Degauss magnetized area(s)
<p>Sluggish or Poor AHRS (ADI) performance</p> <p>Poor AHRS performance in steep bank turns</p> <p>Sluggish compass card</p> <p><i>(Note: may or may not be associated with “Cross Check Attitude” message)</i></p>	a) RSM magnetic interference	a) Survey RSM location using handheld compass per Section 6.9.4. Verify there are no cabin speakers within 3ft of RSM. Degauss any areas found to be magnetized or remove magnetism by other methods.
	b) RSM has become magnetized.	b) With power removed from EFD system degauss RSM and general area using degausser.
	c) “Pitch Attitude Trim” or “Panel Tilt Pitch Compensation” adjustment made without performing a subsequent RSM Calibration.	c) Perform an RSM Calibration per Section 10.5.2
	d) Pitot and/or Static line connections at EFD blocked, kinked, or unplugged.	d) Check pitot/static connections and plumbing for blockage. Check IAS and ALT sensor per Section 10.
	e) Normal after abrupt maneuvers.	e) Perform AHRS Reset

Fault	Cause	Corrective Action
Excessive Heading Lead / Lag during or after turns (>7°)	Magnetic Interference	Verify that all steps have been accomplished to remove magnetic interference (see section 6.9.4), then contact an Aspen Field Service Engineer
Autopilot has lateral offset in GPSS or APPR mode (HDG Bug may also be out of center)	Autopilot roll “null” centering out of adjustment	Follow the autopilot manufacturer’s guidelines for adjusting roll “null” centering
No VDI or glide slope display on EFD	a) CRS pointer more than 100° from lubberline. b) ILS frequency not selected	a) Rotate CRS pointer to lubberline or inbound CRS. b) Select ILS freq on NAV
OBS mode inoperative on GPS	a) GPS A429 IN bus configured wrong	a) See Figure 9.27 for GPS configuration notes
	b) ARINC 429 “A” and “B” lines reversed	b) Correct wiring error to GPS A429 IN bus
Century II/III autopilot performance poor in all modes	Value of R1 set incorrectly	Follow the autopilot manufacturer’s instructions for checking NAV intercept angle. Larger value for R1 will raise angle and smaller value of R1 will lower intercept angle. See Tech Note 2009-06.

## Appendix B : Installation Final Check Sheet

Aircraft Type: \_\_\_\_\_ Date: \_\_\_\_\_

Aircraft Serial Number: \_\_\_\_\_ Tail Number: \_\_\_\_\_

The following five pages must be printed and used during checkout. The Section number refers to the section in the manual where the test is performed. This form must be included in document package to be included in aircraft maintenance records.

**Complete by performing test of Section 10.5.4**

Calibrated Heading Source	Tolerance	Actual EFD Heading	Calibrated Heading Source	Tolerance	Actual EFD Heading
30	+/- 4		210	+/- 4	
60	+/- 4		240	+/- 4	
90	+/- 4		270	+/- 4	
120	+/- 4		300	+/- 4	
150	+/- 4		330	+/- 4	
180	+/- 4		360	+/- 4	

**Complete by performing test of Section 10.6.1**

IAS Setting	Band Color	Band Range	Description	Pass
Vne =	Red	>Vne	Red arc displayed at all speeds above Vne	
Vno =	Yellow	Vno - Vne	Yellow arc extending from Vno to Vne	
Vs =	Green	Vs - Vno	Green arc extending from Vs to Vno	
Vfe =	White	Vso - Vfe	Top of White arc	
Vso =	White		Bottom of White Arc	
Vyse =	Blue Marker	= Vyse	Blue Marker at Vyse	
Vmc =	Red Marker	= Vmc	Red Marker at Vmc	
◀ =	Triangle (White)	= ◀	White triangle at initial flap extension airspeed	

**NOTE**  
Single engine aircraft and aircraft with no flaps will not use all parameters above.

**Aircraft with Vmo/Mmo Airspeed Indicator**

Test	Description	Pass
Barber Pole or Redline Position	Verify the Barber Pole or Redline appears at the correct airspeeds as shown in Table 10-1.	

### Installation Final Check Sheet

SECTION	POST INSTALLATION TESTS	PASS	FAIL
10.5.1.1	Second Phase RSM Location Evaluation – Aircraft “Z” component within NOAA determined Z range?		
10.5.4	Heading Accuracy Check (from Page 1)		
10.5.5	Heading Interference Test		
10.6.1	Indicated Airspeed Test		
10.6.2	Altitude Display Test		
10.6.3	System Leak Test		
10.6.4	AHRS (attitude solution) Test		
10.6.5	GPS Sensor Test		
10.6.6	NAV Receiver Sensor Test – NAV1 (if installed)		
10.6.7	Back-up NAV Indicator Test (if installed)		
10.6.8	Autopilot Sensor Test (if installed)		
10.6.9	Ancillary Equipment Heading and Air Data (if connected)		
10.6.10	List equipment interfaced:		
10.6.11	Battery Capacity Check – Internal battery > 80% Charge		
10.6.12	TAPES Configuration Check		
10.6.13	EMI Test		
10.6.14	Flight Control Interference Check		
10.6.15	OBS Mode Check		

SECTION	COMPLIANCE CHECK	PASS	FAIL
6.4	Weight and Balance performed		
7.1	Electrical Load Analysis performed		
4.4*	A turn and slip (turn coordinator) or standby attitude indicator must be installed in accordance with section 4.4		
4.4*	Existing Airspeed and Altimeter must be remain in “basic T” or original certified configuration in accordance with section 4.4		
4.4.6*	If the airplane is certified for IFR operations and uses the EFD1000 as a backup: A placard must be installed near the EFD1000 E5 stating “ On BAT Dispatch Limit is 80% See EFD1000 E5 AFMS”		

SECTION	COMPLIANCE CHECK	PASS	FAIL
4.5	<p>VFR Installations – The portion of the cockpit placard that permits IFR is obliterated. Add the following placard in full view of the pilot, stating “Operation of This Aircraft is Limited to VFR Only” in the same location as the obliterated statement or near the EFD1000 E5, in the same font size as the other placards in the cockpit. :</p> <div style="border: 1px solid black; padding: 10px; margin: 10px auto; width: fit-content;"> <p style="text-align: center;"><b>Operation of This Aircraft is Limited to VFR Only</b></p> </div>		
4.4.6*	Verify the GPS connected to the EFD1000 E5 is labeled “GPS1” and if a NAV receiver is connected it is labeled “VLOC1”.		
5.1.5	Cessna 190/195 Aircraft s/n 16083 and below only, verify the TAPES are configured to LOCKED OFF, and the original airspeed indicator and altimeter are in the standard “T” arrangement.		
4.4.5*	Backup Nav Indicator (if required) connected to a nav source installed in pilot’s field of view. The indicator must function if the EFD and/or ACU circuit breaker is pulled		
7.2	Circuit breaker installed for the EFD and ACU.		
7.2.11	Verify no wiring/cabling from the backup turn and bank, altimeter, or airspeed indicator is routed directly behind the fan on rear of the EFD1000 E5 display.		
6.9.4	RSM location are <2 degrees of needle deflection on hand held compass within 18”x18”x18” survey area		
1.1	Verify RSM is P/N 900-00003-00x Rev E or later		
10.2	EFD braided ground strap is installed between unit and panel, RSM ground wire attached to ground stud, RSM doubler/mounting plate bonded to airframe ground and ACU(s) chassis bonded to airframe ground. All measure no greater than .003 ohms to ground.		
7.2	Wires, cables, and connectors clearly marked or stamped		
7.2	EFD master switch and/or circuit breaker must be accessible to flight crew and clearly marked.		
11	Post Installation Operational Check		
11.4	Document successful completion of Operational Check in aircraft log book per FAR 91.407b		
6.3	Log book entry stating aircraft has been modified in accordance with EFD1000 E5 AML-STC.		
1.10	Update warranty records on Aspen Avionics website at <a href="http://www.aspenavionics.com/dealerramp">www.aspenavionics.com/dealerramp</a>		
Misc	Complete the Installed Equipment Configuration Matrix in the E5 AFMS (900-00038-001) and insert the completed AFMS in the Airplane Flight Manual. (See sample Appendix C)		

SECTION	COMPLIANCE CHECK	PASS	FAIL
Misc	Complete wire routing diagram in the Instructions for Continued Airworthiness. Complete circuit breaker and switch location diagram Figure 3 in the ICA document.		
Misc	Copy of Aspen Avionics document #900-00012-001 Rev Y or later, Instructions for Continued Airworthiness with copy of wiring diagrams (Section 9 or installer drafted), copy of Configuration Pages Section 10.4.6, and copy of Pre-Modification Checklist Table 5-1 inserted. This data package is to be given to owner/operator for inclusion in aircraft permanent records.		
<b>EA100 Adapter Installations Only:</b>			
Appendix E	"A/P AHRS FAIL" annunciator installed in the pilot primary field of view.		
Appendix E	"A/P AHRS FAIL" annunciator powered from the autopilot main breaker so that the light is illuminated whenever the autopilot is powered but the EA100 is not.		
Appendix E	Insert the completed AFMS in the Airplane Flight Manual, which must be furnished.		
Appendix E	Post EA100 Operational Check resulted in similar or better performance than the Pre EA100 Operational Check.		
* Note - Item may not apply to installations with aircraft limited to VFR - See Figure 4-1A.			

**Inspected by: (print & sign)**

-----  
 Installer / Inspector

-----  
 Date

**Appendix C :**  
**Sample of AFMS Section 1.2**  
**(Installed Equipment Configuration Matrix)**

### Instructions for Printing the AFMS

Each page of the Airplane Flight Manual must be of a type that is not easily erased, disfigured, or misplaced, and is capable of being inserted in the existing approved Airplane Flight Manual.

### How to Fill Out AFMS Section 1.2

The Aircraft Flight Manual Supplement Section 1.2 contains information about the installed configuration of the EFD systems in the customer aircraft. The installer must complete the table in the AFMS before giving the completed AFMS document to the customer.

Enter a “✓” in all applicable boxes noting the installed equipment and backup equipment type.

### Sample – Installed Equipment Configuration Matrix

The following sample installation is an EFD1000 E5 with a GNS-430W and an EA100. It is using the Turn and Slip indicator as the back-up attitude.

Available Equipment	Installed Equipment	Remarks
EFD1000 E5 with Internal Battery	✓	
EA100 A/P AHRS	✓	
VLOC1 integrated with the EFD1000 E5 System	✓	GNS-430W
GPS1 integrated with the EFD1000 E5 System	✓	GNS-430W

Table 1 Installed Equipment List

Table 2 is used to identify the backup equipment applicable to this aircraft’s installation. This table is completed during installation by the installation facility.

Standby Equipment	Installed Equipment	Remarks
Electric Turn and Slip indicator or Turn Coordinator	✓	
Standby Attitude Indicator	✓	
Standby Altimeter	✓	
Standby Airspeed Indicator	✓	
Magnetic Compass	✓	

Table 2 Backup Instrument Configuration for the EFD1000 E5

THIS PAGE IS INTENTIONALLY LEFT BLANK

## **Appendix D : Component Maintenance Manual (CMM)**

## Component Maintenance Manual

The following is information on the periodic maintenance, calibration and repair, for the continued airworthiness of the Electronic Map Displays, including recommended inspection intervals and service life:

**Periodic Maintenance:** None beyond that which is described in the Instructions for Continued Airworthiness.

**Calibration:** None beyond that which is described in the Instructions for Continued Airworthiness.

**Repair:** On Condition

**Recommended Inspection Intervals:** None beyond that which is described Aspen Avionics document #900-00012-001, Instructions for Continued Airworthiness.

**Service Life:** None Specified

Field Replaceable Parts	
Description	Aspen Part Number
EFD Internal Battery - white connector	409-00003-002
EFD "SYNC" knobs (CRS/HDG knob)	520-00020-001

### EFD Knob Replacement Procedure

The knob(s) are removed by gripping the knob with the fingers of your hand and then pulling straight off the shaft using moderate force. Install the new knob P/N 520-00020-001 by pushing the knob on to the shaft with the fingers of your hand until it bottoms out. After knob replacement, power-up the system and verify the knob can turn freely and that the "push to enter" function operates properly by accessing the HDG bug or CRS pointer function.

### EFD Internal Battery Replacement Procedure

See the Instructions for Continued Airworthiness.

## **Appendix E : EA100 Adapter**

### **Optional Autopilot Attitude Adapter**

**Replaces the Bendix-King**

**KG258/KI254/KI255/KI256**

**to the KAP100/150 and KFC150/200/250 autopilots**

**And**

**Replaces the Century**

**52D66/52D67/52D166/52D167/52D266/52D267/52C77**

**to the Century 21/31/41/2000/4000/IIB/III/IV autopilots**

The EA100 Adapter is an optional sub-component of the required EFD1000 E5 system designed to replace the Bendix King KG-258, KI-254, KI-255, KI-256 and the Century 52D66, 52D67, 52D166, 52D167, 52D266, 52D267 and 52C77 (hereafter known as Century AI) attitude indicators when connected to the approved autopilots in this appendix. The EA100 converts the digital pitch and roll signals of the EFD1000 into equivalent analog signals.

The EA100 is approved to replace the King or Century AI for any autopilot model shown in the wiring diagrams of this appendix.

Removal of the KG-258, KI-254 and Century AI (without flight director, 52C77) is approved by this STC when an EA100 is installed.

KI-255, KI256 and Century AI/FD indicators must not be removed as the EFD1000 E5 cannot display FD commands. Therefore these indicators must be relocated to the area within the pilot's primary maximum field of view in accordance with FAR 23.1321(a), see Section 4.4.3

## E1 General Limitations

The EA100 is only eligible to replace the analog outputs from a KI-254/255/256 or KG-258, or the Century AI flight command Indicator to a compatible autopilot, as identified by the wiring diagrams in this appendix.

### NOTE

*A Pre-Installation Operational Check is recommended to verify that the autopilot performance is satisfactory prior to starting the EA100 installation. Autopilot problems should be corrected prior to the EA100 installation as troubleshooting post installation autopilot issues will be much easier if the autopilot performance was base lined prior to install. See Pre-installation Operational Check in this Appendix.*

## E2 EA100 Specifications

### General Specifications:

Part Number .....	910-00013-001
Width .....	6.83 in. including mounting flanges
Height .....	1.85 in.
Length.....	4.28 in.
Weight.....	1.25 lbs.

### Operational Specifications:

Operating Temp .....	-20°C to +55°C
Storage Temp .....	-55°C to +85°C
Max Operating Altitude .....	55,000 ft.
Cooling .....	None Required
Max Humidity .....	95% at 50°C
Input Voltage.....	+14 and 28 VDC
Nominal Current.....	0.25/0.5 Amps (28v/14v)

### I/O Specifications:

Ethernet Port .....	1 Digital
Autopilot Pitch gyro Out ....	1 Analog
Autopilot Roll gyro Out.....	1 Analog
Autopilot gyro Ref In .....	1 Analog
AP Disc Relay.....	1 Output
ATT Fail Relay.....	1 Output
Signal Output .....	Attitude Reference Signals (Roll and Pitch), configurable to King and Century gyro levels.

### Certification Specifications:

The EA100 is certified as a sub-component of the required EFD1000 system

#### Software:

RTCA DO-178B ..... Level C

*Complex Electronic Hardware (CEH):* NONE

#### Environmental:

RTCA DO-160E ..... See Environmental Qualification Form this Appendix

E3 Outline Drawing:

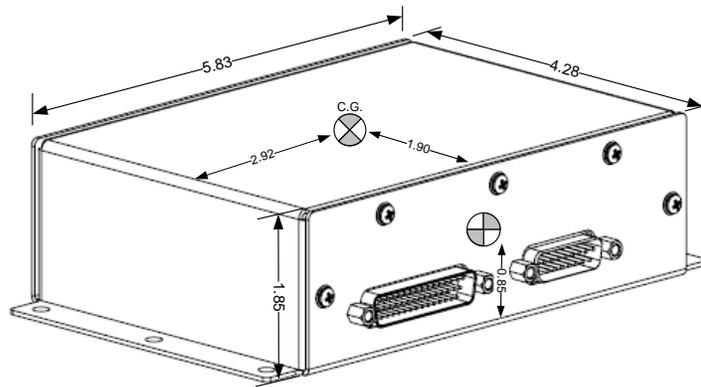

Figure E1: EA100 Outline Drawing (inches) and center of gravity

E4 EA100 System Architecture

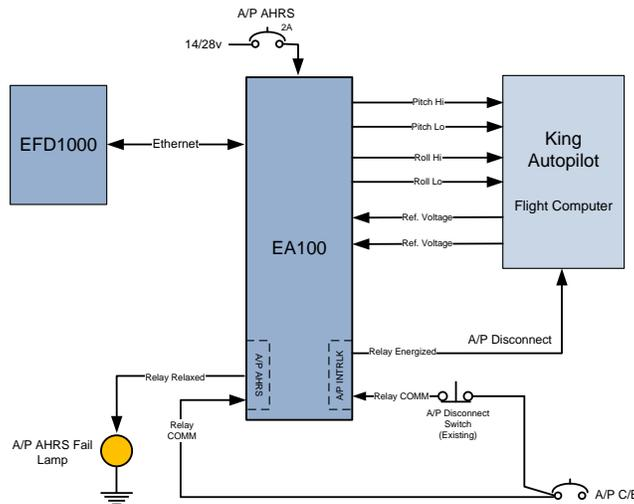

Figure E2: EA100 Block Diagram (Bendix King Autopilots)

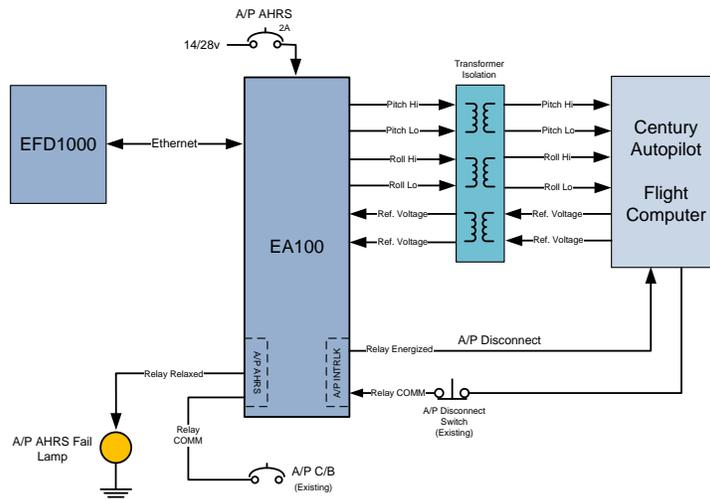

Figure E3: EA100 Block Diagram (Century Autopilots)

## E5 EA100 Installation

### Installation Limitations

- An IFR GPS must be connected to the EFD1000 E5 that is connected to the EA100.
- The EA100 must be installed in a temperature-controlled part of the aircraft.
- The EA100 must not be installed on the firewall.
- Maximum Ethernet cable length between the EFD and the EA100 is 30 feet.
- An “A/P AHRS FAIL” light (amber) must be installed in the pilot primary field-of-view.
- The FAA approved AFMS revision with the Configuration Matrix completed must be inserted in the Airplane Flight Manual.

### E5.1 Equipment Location Documentation

The AML-STC requires recording of the EA100 mounting location in the Instructions for Continued Airworthiness. In addition, the location of the “A/P AHRS FAIL” annunciator and an accurate description of the wire and cable routing must be shown on those figures.

### E5.2 Weight and Balance

Using the EA100 weight from the table below and the moment arm of the mounting location perform a weight and balance calculation per AC 43.13-1B Chapter 10. Also account for equipment removed during the modification process.

Component	Weight (mass)
EA100 Adapter	1.25lbs (0.57Kg)

**Table E2: EA100 Component Weight**

### E5.3 Mechanical Installation

It is recommended to mount the EA100 as close to the autopilot computer as possible.

The EA100 has no user interface, and therefore can be remote mounted in any orientation as long as it is accessible. Orientation with the connectors facing upwards is not recommended due to the potential for accumulated water in the connectors. The optimum mounting location is an area that minimizes wire runs to interfacing equipment. This typically means near the autopilot computer or near the attitude gyro it is replacing.

**NOTE**

*The EA100 has been tested for normal operation over a temperature range from -20C to +55C, and for short time operations from -40C to +70C. This qualification permits installation in non-pressurized but temperature controlled regions of aircraft operated up to 50,000ft. For all aircraft on the EFD1000 AML STC installation in a temperature controlled region of the aircraft is acceptable. Should an alternate location be selected the installer must validate that the temperature in the alternate location is within the equipment’s qualified temperature range.*

Locate the EA100 on an existing avionics shelf, radio rack, or cabin or cockpit floor. Attach to material and structure that is appropriate for equipment mounting, using appropriate fasteners and corrosion control. The EA100 is suitably protected against corrosion. Do not permit other parts of the aircraft or cabling to abrade against the EA100. Installation of the EA100 must be in accordance with AC43.13-2B, Chapter1 Paragraphs 100 to 114, pages 1 to 8.

An unpainted surface of the EA100 case must be bonded to aircraft ground either through mounting to a metal shelf or with an installer fabricated bonding strap or wire braid no more than 12 inches in length. Attach ground lug of bonding strap to one of the mounting screws if required. Refer to AC 43.13-1B paragraphs 11-187 to 11-190, pages 11-73 to 11-79 for additional bonding information.

Verify EA-100 case to airframe ground has  $\leq 3$  milliohms of resistance.

Shelf or bracket fabrication is beyond the scope of this STC and will require separate FAA approved data.

Structural DER analysis or static testing should be accomplished to the following ultimate load factors for items of mass within the cabin or cockpit: upward and downward 10.0g, forward 18.0g, aft and sideward 4.5g. The load factors should be multiplied by the weight of the EA100 plus any attachment brackets and hardware. See AC43.13-2B, Chapter1 Paragraph 103, page 2 and Paragraph 105, page 3. Structural Sizing and Analysis must be accomplished for the installation location in accordance with AC43.13-2B, Chapter1 Paragraph 104, page 2. Materials and workmanship must be accomplished in accordance with AC43.13-2B, Chapter1 Paragraph 106, page 4.

Mount the EA-100 using six (6) MS35206 #8-32 screws, six (6) NAS1149FN832P washers, and six (6) MS21044N08 #8-32 self-locking nuts. Tighten nuts to 12 in-lbs.

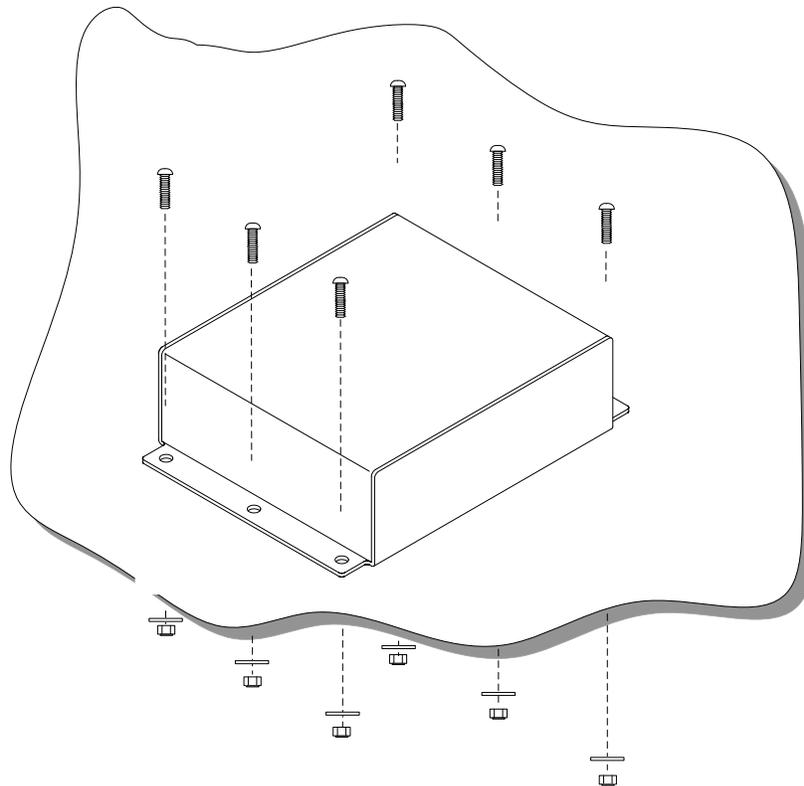

**Figure E4: EA100 Mounting**

### E5.4 Electrical Installation

The Electrical installation of the EA100 will involve the following steps:

**NOTE**

*The EFD1000 E5 does not display Flight Director information. The existing AI/FD indicator must be retained and relocated to a position in the pilots field of view.*

- 1) Century only, build transformer TR1 or TR2 as per instructions in this appendix.
- 2) Wire the main connections to the EA100 as shown in Figure E8.
- 3) Wire the appropriate autopilot connections as shown in Figures E9 thru E22.
- 4) KI254 installations only, the KI254 electric gyro used an attitude valid to the autopilot computer. Remove this wire as open logic equals valid to the KC19X computer.

**NOTE**

*If the existing gyro is supplying radar stabilization then these wires should be separated from the autopilot wires and connected to the EA100 Aux output as the AP Output may not be capable of driving both loads.*

**CAUTION**

*Radar Installations Only – the AUX EXCITE HI input is limited to 32Vp-p maximum voltage. Some 26V inverters are not well regulated and can exceed this voltage.*

Perform an electrical load analysis to verify the aircraft complies with FAR 23.1351(a) using the current draw of the EA100 from the table below. Refer to AC 43.13-1B paragraphs 11-35 and 11-36, page 11-12 for additional information on Electrical Load determination and control.

Component	Current Draw (amps)
EA100 Adapter	0.25A @ 28Vdc
	0.50A @ 14Vdc

**Table E3: EA100 Current Draw**

A two-ampere trip-free resettable (push-pull type) circuit breaker must be installed for the EA100 in a location accessible to the pilot while seated. The power source for the EA100 is the same as that of the autopilot computer. In most cases this is the avionics buss. The source could be the switched battery buss through an autopilot on/off switch. The breaker must be labeled “A/P AHRS”. Record the location of circuit breaker on Figure 3 of Aspen Avionics document #900-00012-001, Instructions for Continued Airworthiness.

An “A/P AHRS FAIL” annunciator light must be installed in the pilot primary field-of-view. The light must have the following specifications:

- Lens color must be Amber.
- There must be a push-to-test function or momentary on switch so that the A/P AHRS lamp can be tested prior to each flight. The integrated “dimnable cat’s-eye” light/switch (MS25041-4) has a momentary lamp test and is labeled Push to Test.
- The light must be dimmable for night and yet readable and discernible in sunlight and free from glare and reflections that could interfere with the pilot's vision in all operations for which the aircraft is certified. The light must be installed so that their direct rays, and rays reflected from the windshield or other surface, are shielded from the pilot's eyes.
- The power source for the light must come from the EA100 A/P AHRS relay.
- The “A/P AHRS FAIL” label is required and must be of a text size similar to other labels in the panel and be readable and discernible (lit) at night.

**NOTE**

*Due to the above specifications it is recommended to use the “dimnable cat’s-eye” integrated lamp/switch (MS25041-4) as it meets all the requirements above once positioned appropriately and labeled “A/P AHRS FAIL”.*

Primary Field-of-View for the purpose of this STC uses the location of the EFD as the measuring point. The A/P AHRS FAIL light must be within the box defined in Figure E5 below. The lamp and label should be viewable from the normal seated position with minimum head movement. Record the location of the light on Figure 3 of Aspen Avionics document #900-00012-001, Instructions for Continued Airworthiness.

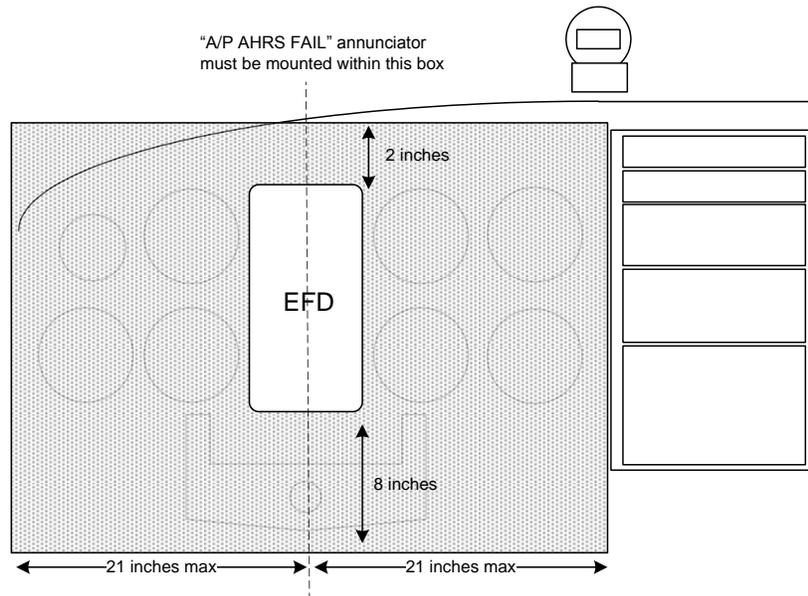

**Figure E5: A/P AHRS FAIL Annunciator Location**

MIL-C-27500 shielded wire and MIL-W-22759 single conductor wire should be used. All wires should be fabricated as shown, keeping all grounds as short as possible.

The Ethernet cable between the EA100 and the EFD1000 has a maximum cable length of 30ft. This cable is an Aspen-supplied component.

Wires and connectors must be clearly marked per FAR 23.1365(d).

Wires and wiring bundles must be secured in such a way to eliminate risk of mechanical damage and minimize exposure to heat and fluids per FAR 23.1365(e).

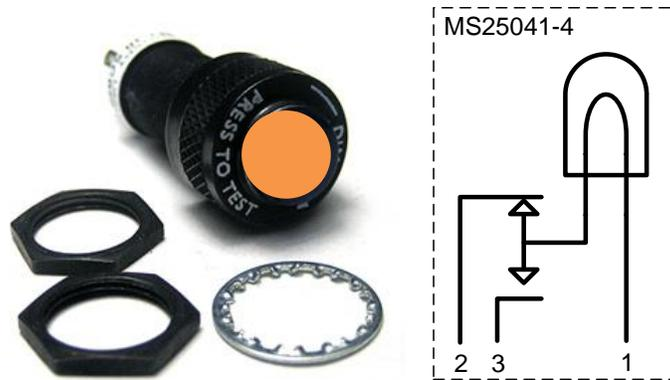

Figure E6: MS25041-4 Dimmable "Catseye"

### E5.5 Fabrication of TR1 or TR2 Transformer Isolation box (Century autopilots only)

It is necessary to isolate the Century autopilot inputs from ground with isolation transformers. The transformers are standard parts. An appropriately rated certificate holder with a quality system can fabricate a part in accordance with Part 43. The standard parts can be contained in a junction box as described below. See AC 43.13-1B and -2B for additional information.

- a) Follow practices described in AC 43.13-1B, Chapter 11 section 11-37 page 11-13 for junction box construction.
- b) The junction box that houses the transformers must be aluminum. Use of a D-sub connector (DB-15) is suggested with the wires connected per Figure E7 or E7A below.
- c) Select the appropriate TR Junction box:
  - i. TR1 - Century 21/31/41/2000/4000, the three (3) transformers are Triad SP-66 (MIL# TF5S2 1ZZ). Note - The roll only Century 21 autopilot only uses two transformers (T1 and T3).
  - ii. TR2 - Century IIB/III/IV, T1 is a SP20 transformer and T2/T3 are SP69 transformers. The roll only Century IIB autopilot only uses two transformers (T1 and T3). Install 2.2K ohm and 1.21K ohm resistors from 403-00009-001 bag as shown. Install 0.12uF capacitor from bag as shown.
- d) Secure transformers in such a way that they cannot become loose and short out. One way is with a circuit board (bread board) attached with stand offs and the transformers soldered on the backside using the circuit board traces or jumper wire. The relay should be attached to the board or lid of the junction box.
- e) Secure all mounting hardware with locking fasteners so that they cannot come loose in the box.
- f) If a box is used to mount the components, permanently label the box with "ASPEN EA100 TRANSFORMERS TR1" (or TR2) as applicable so that it is clearly visible.
- g) Mark the location of the box in the in the ICA number 900-00012-001 on Figures 1, 2 or 3 as applicable.

- h) The box TR1 or TR2 must be mounted to a metal structure/shelf or bonded to a ground point by a bonding strap in a location that is accessible for inspection.
- i) Shelf or bracket fabrication is beyond the scope of this STC and will require separate FAA approved data.
- j) The box TR1 or TR2 can be mounted in any location of the aircraft that is approved for EA100 mounting.

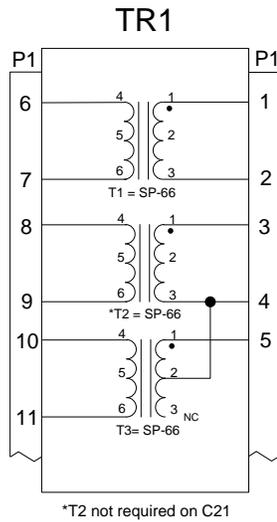

Figure E7: TR1 – Century 21/31/41/2000/4000

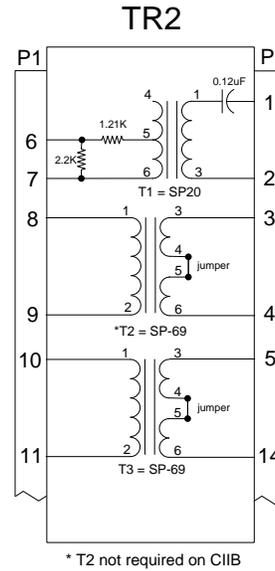
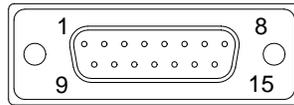

Figure E7A: TR2 – Century IIB/III/IV

**E5.6 Electrical Connection**  
*EA100 P1 Connector*



PIN	NAME	INPUT/ OUTPUT	FUNCTION
1	ETHERNET TX-	OUTPUT	ETHERNET TX- OUT TO EFD1000
2	ETHERNET TX+	OUTPUT	ETHERNET TX+ OUT TO EFD1000
3	RESERVED		
4	RESERVED		
5	RESERVED		
6	RESERVED		
7	GND		AIRCRAFT GROUND
8	POWER	INPUT	AIRCRAFT POWER 9-28VDC
9	ETHERNET RX-	INPUT	ETHERNET RX- IN FROM EFD1000
10	ETHERNET RX+	INPUT	ETHERNET RX+ IN FROM EFD1000
11	RESERVED		
12	RESERVED		

13	RESERVED		
14	GND		AIRCRAFT GROUND
15	POWER	INPUT	AIRCRAFT POWER 9–28VDC

Table E4: EA100 P1 Connector Pin Out

EA100 P2 Connector

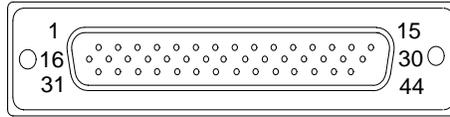

PIN	NAME	INPUT/ OUTPUT	FUNCTION
1	AP EXCITE HI	INPUT	ATTITUDE REFERENCE HI
2	AP PITCH HI	OUTPUT	PITCH HI
3	AP ROLL HI	OUTPUT	ROLL HI
4 -15	RESERVED		
16	AP EXCITE LO	INPUT	ATTITUDE REFERENCE LO
17	AP PITCH LO	OUTPUT	PITCH LO
18	AP ROLL LO	OUTPUT	ROLL LO
19	AUX EXCITE LO	INPUT	ATTITUDE REFERENCE LO
20	AUX PITCH LO	OUTPUT	PITCH LO
21	AUX ROLL LO	OUTPUT	ROLL LO
22-30	RESERVED		
31	AUX EXCITE HI	INPUT	ATTITUDE REFERENCE HI (32Vp-p max)
32	AUX PITCH HI	OUTPUT	PITCH HI
33	AUX ROLL HI	OUTPUT	ROLL HI
34-38	RESERVED		
39	A/P INTRLK COMM	INPUT	“COMM” CONTACT ON RELAY
40	A/P INTRLK RELAXED	OUTPUT	RELAXED STATE OF RELAY
41	A/P INTRLK ENERGIZED	OUTPUT	ENERGIZED STATE OF RELAY
42	A/P AHRS VALID	OUTPUT	ENERGIZED STATE OF RELAY
43	A/P AHRS INVALID	OUTPUT	RELAXED STATE OF RELAY
44	A/P AHRS COMM	INPUT	“COMM” CONTACT ON RELAY

Table E5: EA100 P2 Connector Pin Out

AML STC SA10822SC approves use of the Pitch/Roll attitude outputs for the autopilots identified in this installation data. Other applications were not evaluated under this STC. Other uses of the TSO EA100 equipment must have separate approval for installation in an aircraft. Refer to the TSO Installation Instructions (Aspen document 900-00018-001).

E5.7 Wiring Diagrams

- A. Wire Figure E8 in all installations.
- B. Select Figure E9 – E22 depending on autopilot type and wire as shown.
- C. Century autopilots only, build transformer box TR1 or TR2 as shown in Figure E7 or E7A and per instructions in Section E5.5.

**GENERAL INSTALLATION NOTES**

All wires in this section 22AWG unless otherwise specified  
 All grounds should be as short as possible  
 Terminate all shields within connector back shell

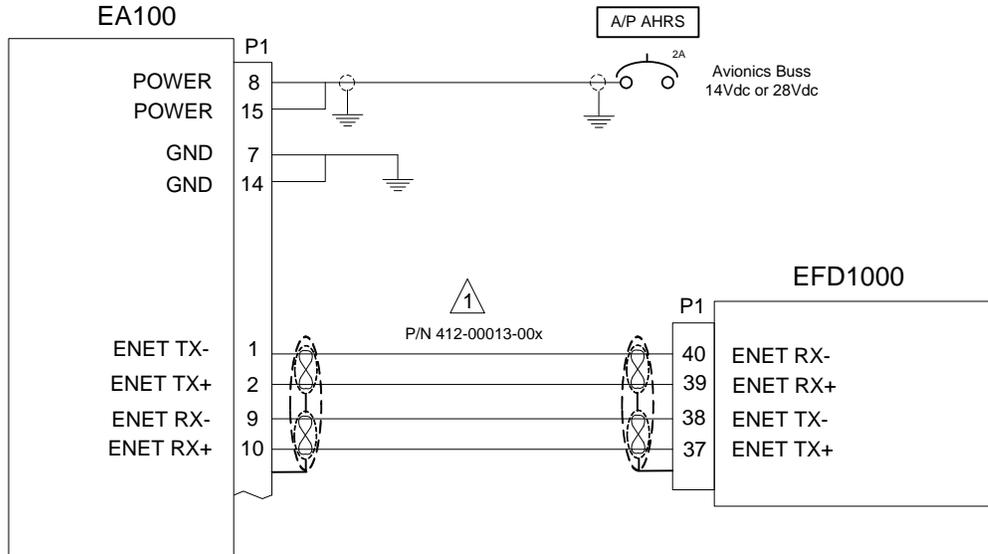

1 EA100 to EFD1000 Ethernet connection must use Aspen P/N 412-00013-00x cable. Shields must be terminated within the EA100 and EFD back shells to pass EMI/RFI interference tests.

**Figure E8: EA100 Main Wiring Connections(King and Century)**

**GENERAL INSTALLATION NOTES**

All wires in this section 22AWG unless otherwise specified  
 All grounds should be as short as possible  
 Terminate all shields within connector back shell

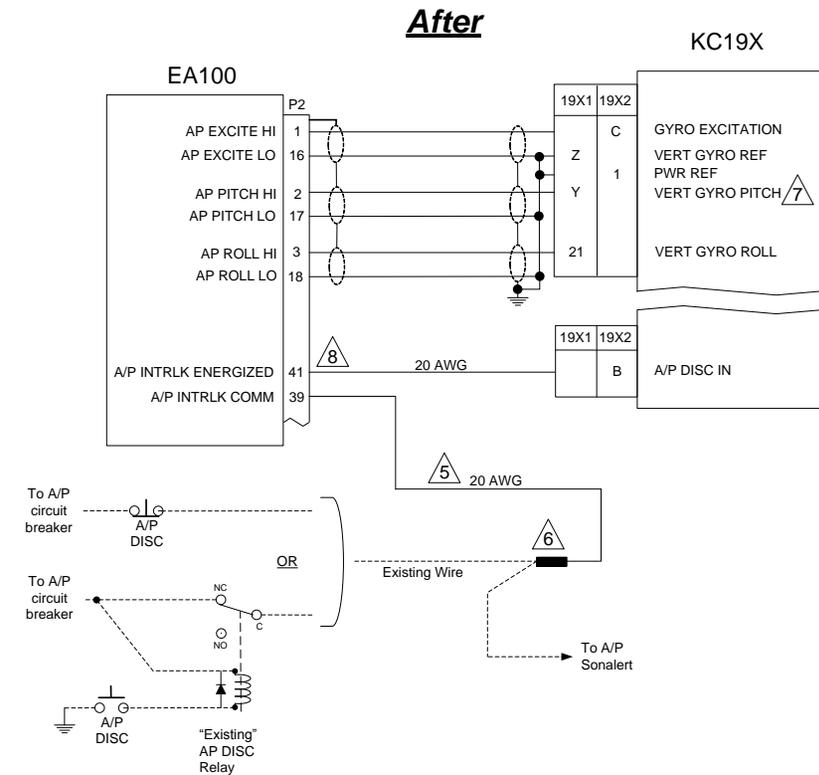
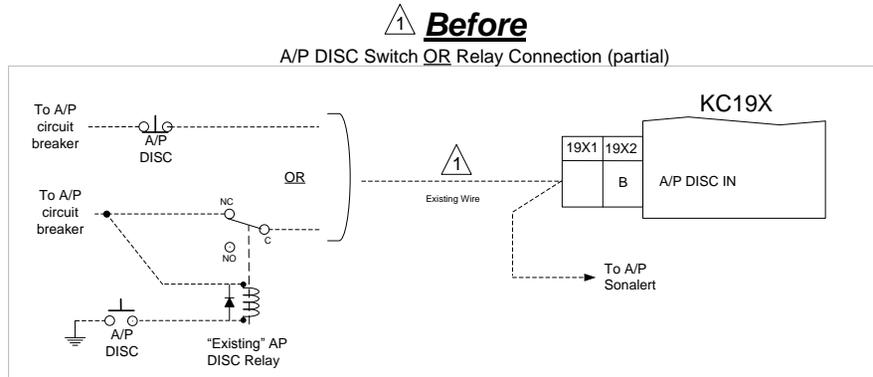
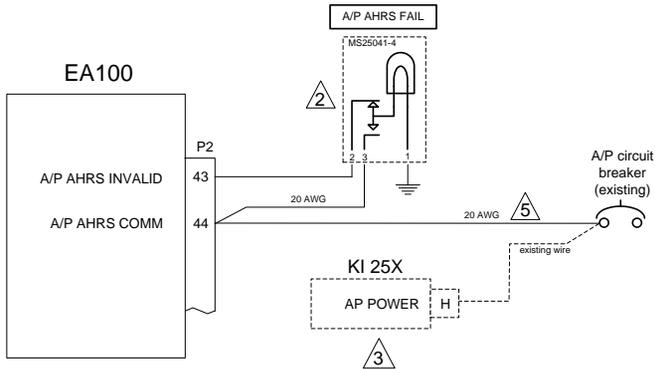

- 1 The existing autopilot disconnect circuit must be run through an internal relay within the EA100. This ensures the autopilot cannot be engaged or will disengage if the EA100 attitude is invalid. The autopilot "sonalert" or disconnect tone must not be interrupted with this relay. Wire as shown.
- 2 A/P AHRS FAIL light must be installed in the pilots primary field of view. Use light/dimmer/ test switch P/N MS25041-4. Wire as shown.
- 3 KFC autopilots with flight director will retain the KI255/256 for FD display.
- 4 Note 4 not applicable to this drawing
- 5 Use 20 AWG or wire size appropriate for A/P circuit breaker rating. Wire may be spliced to a 22 AWG wire not more than 4 inches in length at the EA100 to accommodate the high density pin size.
- 6 Remove wires from KC19X2-B. The wires should be spliced together with a third wire which will be connected to the EA100 pin 39. Connect EA100 pin 41 to KC19X2-B.
- 7 No connect on KAP100
- 8 20 AWG wire may be spliced to a 22 AWG wire of no more than 4 inches in length at the EA100 to accommodate the high density pin.

Figure E9: EA100 to KAP100/KAP150/KFC150 Attitude Source w/DISC

**GENERAL INSTALLATION NOTES**

All wires in this section 22AWG unless otherwise specified  
 All grounds should be as short as possible  
 Terminate all shields within connector back shell

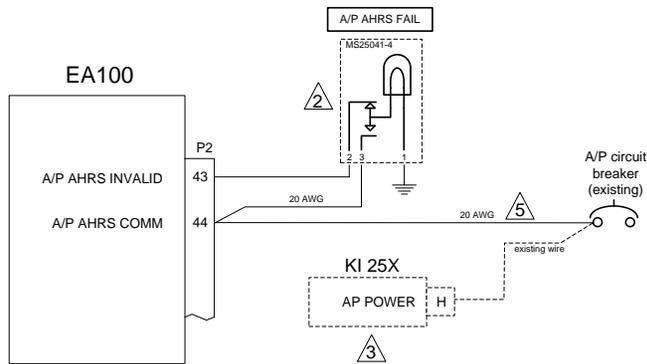

- 1 The existing autopilot disconnect circuit must be run through an internal relay within the EA100. This ensures the autopilot cannot be engaged or will disengage if the EA100 attitude is invalid. The autopilot "sonalert" or disconnect tone must not be interrupted with this relay. Wire as shown.
- 2 A/P AHRS FAIL light must be installed in the pilots primary field of view. Use light/dimmer/test switch P/N MS25041-4. Wire as shown.
- 3 KFC autopilots with flight director will retain the KI255/256 for FD display.
- 4 Note 4 not applicable to this drawing
- 5 Use 20 AWG or wire size appropriate for A/P circuit breaker rating. Wire may be spliced to a 22 AWG wire not more than 4 inches in length at the EA100 to accommodate the high density pin size.
- 6 Remove existing wire from P2902 pin D and extend to EA100 pin 39. Run new wire from P2902 pin D to EA100 pin 41. Verify optional yaw axis wire is on pin 41 side of EA100.
- 7 20 AWG wire may be spliced to a 22 AWG wire of no more than 4 inches in length at the EA100 to accommodate the high density pin.

**Before**  
 A/P DISC Relay Connection (partial)

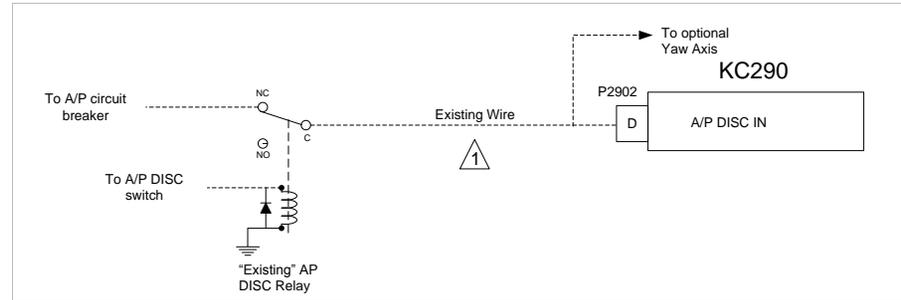

**After**

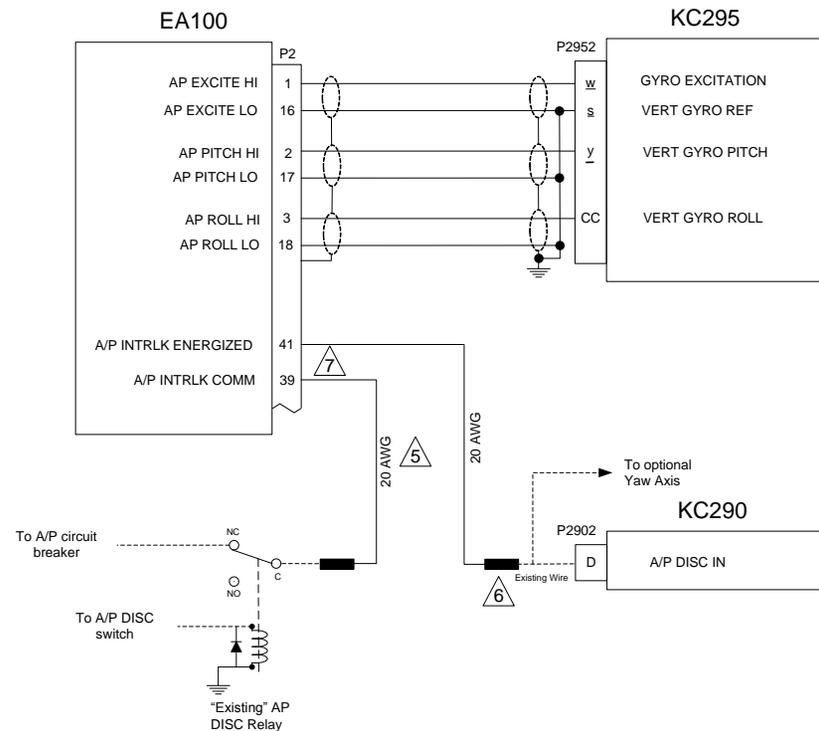
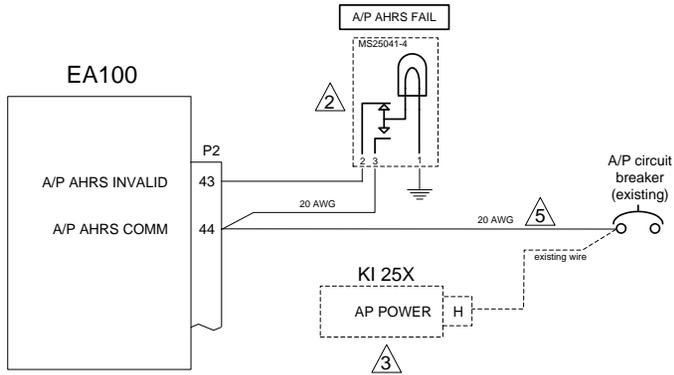

Figure E10: EA100 to KAP/KFC200 Attitude Source w/DISC

**GENERAL INSTALLATION NOTES**

All wires in this section 22AWG unless otherwise specified  
 All grounds should be as short as possible  
 Terminate all shields within connector back shell



- 1 The existing autopilot disconnect circuit must be run through an internal relay within the EA100. This ensures the autopilot cannot be engaged or will disengage if the EA100 attitude is invalid. The autopilot "sonalert" or disconnect tone must not be interrupted with this relay. Wire as shown.
- 2 A/P AHRs FAIL light must be installed in the pilots primary field of view. Use light/dimmer/ test switch P/N MS25041-4. Wire as shown.
- 3 KFC autopilots with flight director will retain the KI255/256 for FD display.
- 4 Note 4 not applicable to this drawing
- 5 Use 20 AWG or wire size appropriate for A/P circuit breaker rating. Wire may be spliced to a 22 AWG wire not more than 4 inches in length at the EA100 to accommodate the high density pin size.
- 6 Remove existing wire from P2251 pin 9 and extend to EA100 pin 39. Run new wire from P2251 pin 9 to EA100 pin 41.
- 7 20 AWG wire may be spliced to a 22 AWG wire of no more than 4 inches in length at the EA100 to accommodate the high density pin.

**Before**

A/P DISC Connection (partial)

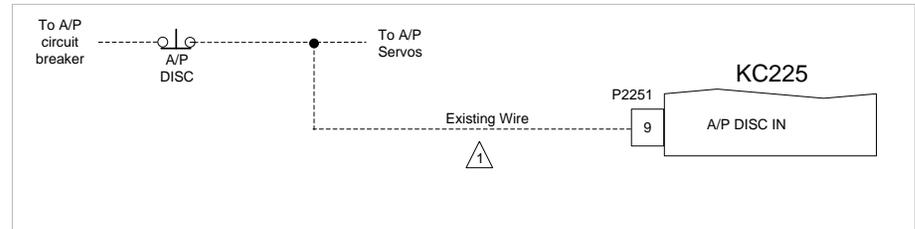

**After**

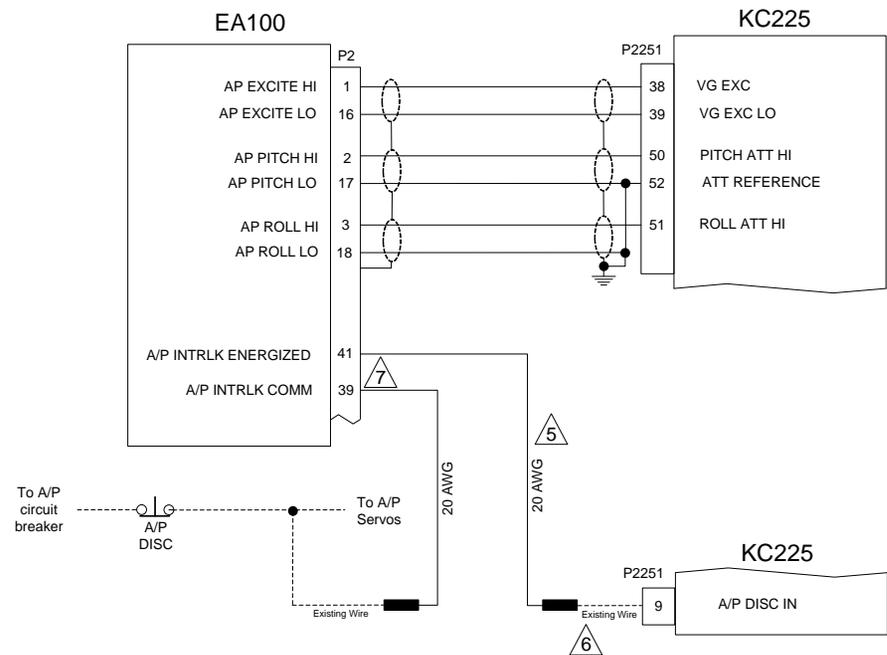
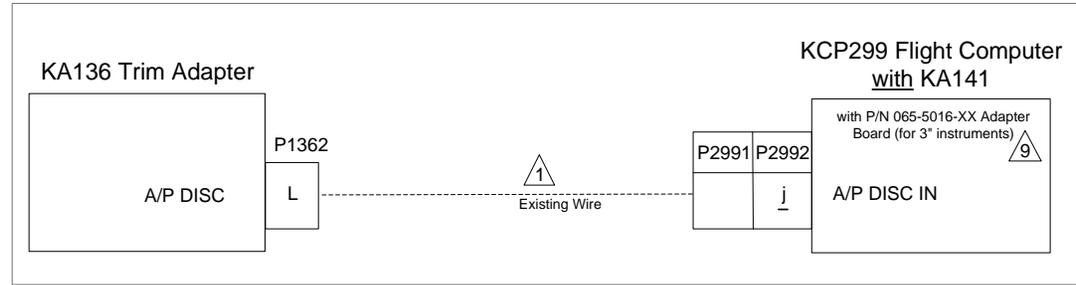
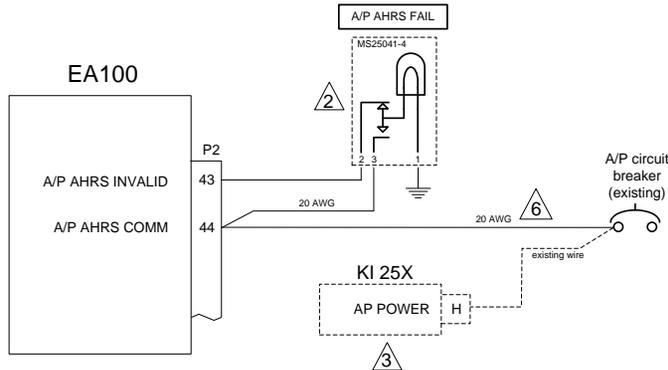

Figure E11: EA100 to KFC225 Attitude Source w/DISC

**GENERAL INSTALLATION NOTES**

All wires in this section 22AWG unless otherwise specified  
 All grounds should be as short as possible  
 Terminate all shields within connector back shell

**1 Before**  
 A/P DISC from KA136 to KCP299



**After**

- 1** The existing autopilot disconnect circuit from the KA136 must be run through an internal relay within the EA100. This ensures the autopilot cannot be engaged or will disengage if the EA100 attitude is invalid. Wire as shown.
- 2** A/P AHRs FAIL light must be installed in the pilots primary field of view. Use light/dimmer/test switch P/N MS25041-4. Wire as shown.
- 3** KFC autopilots with flight director will retain the KI255/256 for FD display.
- 4** Note 4 not applicable to this drawing
- 5** KFC250 autopilots that do not use a KA141 cannot use this drawing. See appropriate wiring diagram in this manual.
- 6** Use 20 AWG or wire size appropriate for A/P circuit breaker rating. Wire may be spliced to a 22 AWG wire not more than 4 inches in length at the EA100 to accommodate the high density pin size.
- 7** Remove existing wire from P2992 pin j and extend to EA100 pin 39. Run new wire from P2992 pin j to EA100 pin 41.
- 8** Wire from KA141-4 to KI256-E is a ground reference from the KA141. If removing the KI256, it is not necessary to ground this wire.
- 9** Only KCP299 flight computers with adapter board 065-5016-XX may use this drawing. Flight computers with 065-5015-XX adapter boards not approved.
- 10** 18 AWG wire may be spliced to a 22 AWG wire of no more than 4 inches in length at the EA100 to accommodate the high density pin.

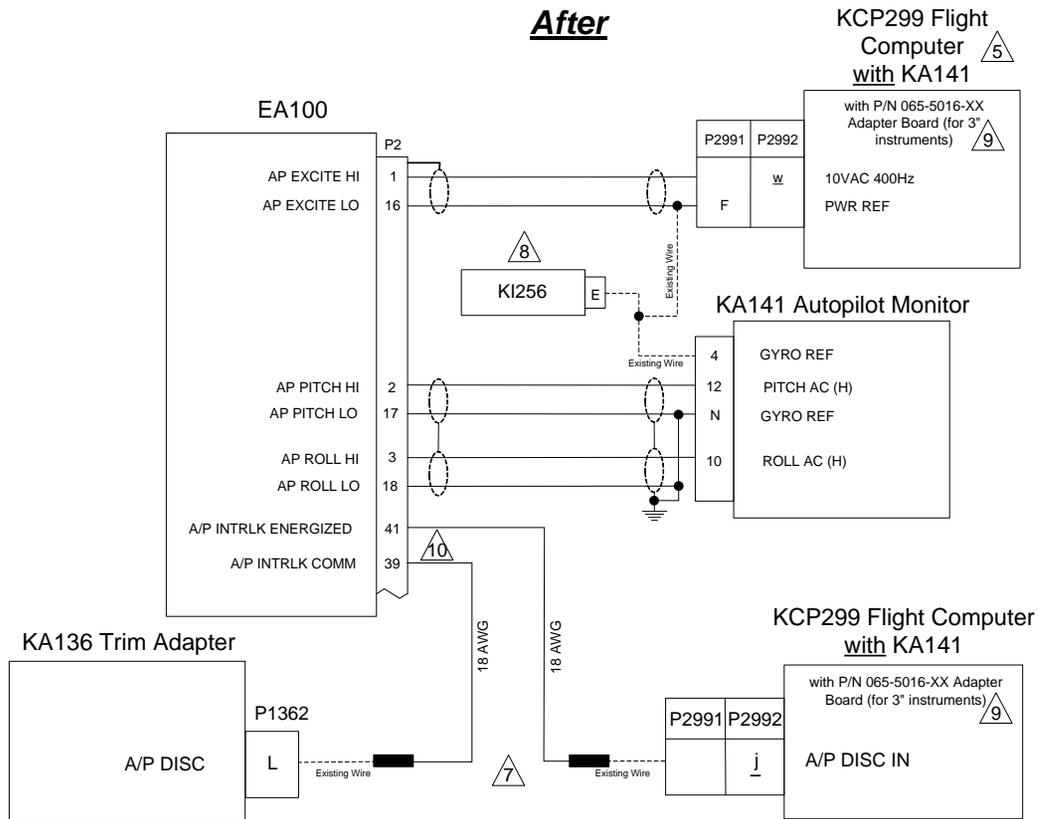
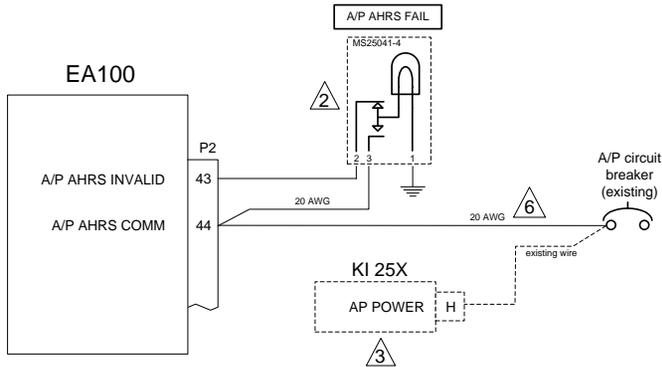

Figure E12: EA100 to KFC250 (with KA141) Attitude Source w/DISC

**GENERAL INSTALLATION NOTES**

All wires in this section 22AWG unless otherwise specified  
 All grounds should be as short as possible  
 Terminate all shields within connector back shell



- 1 The existing autopilot disconnect circuit from the KA136 must be run through an internal relay within the EA100. This ensures the autopilot cannot be engaged or will disengage if the EA100 attitude is invalid. Wire as shown.
- 2 A/P AHRS FAIL light must be installed in the pilots primary field of view. Use light/dimmer/test switch P/N MS25041-4. Wire as shown.
- 3 KFC autopilots with flight director will retain the KI255/256 for FD display.
- 4 Note 4 not applicable to this drawing
- 5 KFC250 autopilots with a KA141 cannot use this drawing. See appropriate wiring diagram in this manual.
- 6 Use 20 AWG or wire size appropriate for A/P circuit breaker rating. Wire may be spliced to a 22 AWG wire not more than 4 inches in length at the EA100 to accommodate the high density pin size.
- 7 Remove existing wire from P2992 pin j and extend to EA100 pin 39. Run new wire from P2992 pin j to EA100 pin 41.
- 8 Only KCP299 flight computers with adapter board 065-5016-XX may use this drawing. Flight computers with 065-5015-XX adapter boards not approved.
- 9 18 AWG wire may be spliced to a 22 AWG wire of no more than 4 inches in length at the EA100 to accommodate the high density pin.

Figure E13: EA100 to KFC250 (without KA141) Attitude Source w/Disc

1 Before  
 A/P DISC from KA136 to KCP299

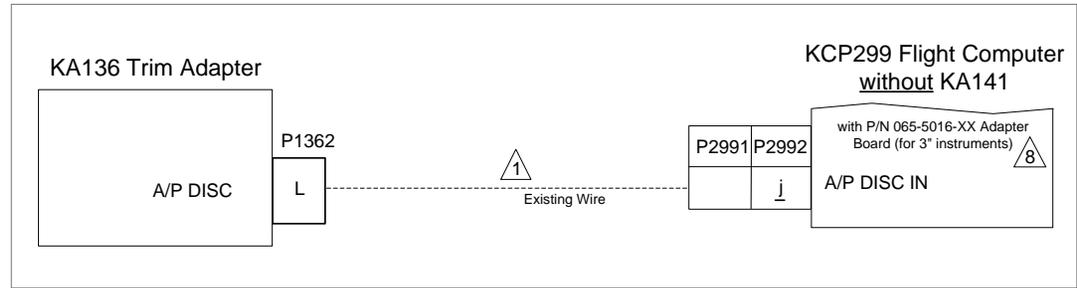

After

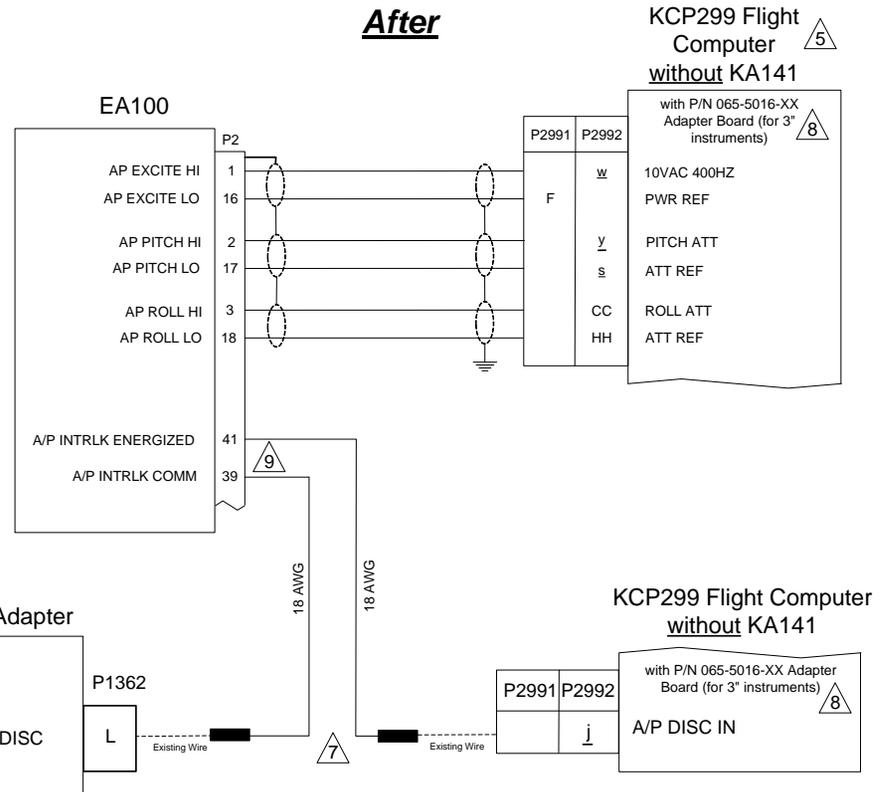
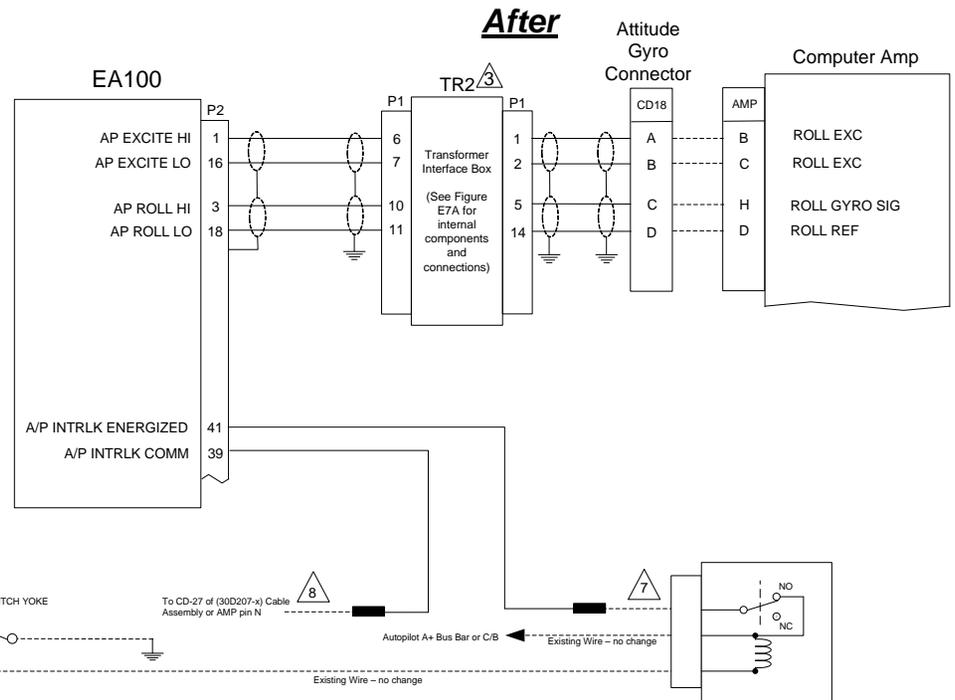
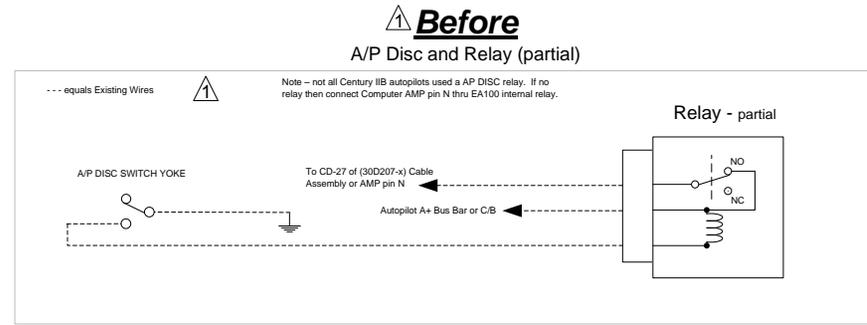
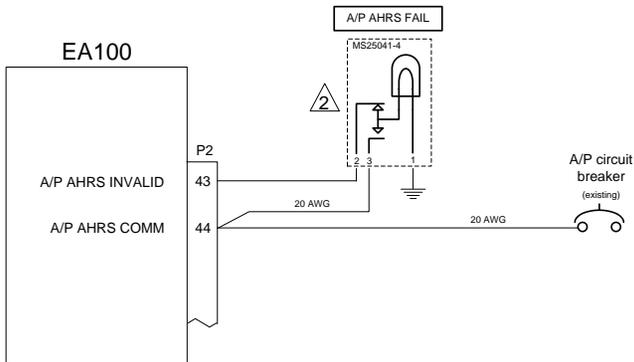

Figure E14: Reserved

**NOTE - The EA100 must be configured using the EA100 Tool, See Section E5.8 in this document.**

**GENERAL INSTALLATION NOTES**

All wires in this section 22AWG unless otherwise specified  
 All grounds should be as short as possible  
 Terminate all shields within connector back shell



- 1 The existing autopilot disconnect circuit must be run through an internal relay within the EA100. This ensures the autopilot cannot be engaged or will disengage if the EA100 attitude is invalid. The autopilot "sonalert" or disconnect tone must not be interrupted with this relay. Wire as shown.
- 2 A/P AHRS FAIL light must be installed in the pilots primary field of view. Use light/dimmer/test switch P/N MS25041-4. Wire as shown. Use 14v or 28v bulb as appropriate.
- 3 TR2 Transformer/Relay Interface box must be field fabricated using the instructions in this Appendix.
- 4 No flight director with Century IIB
- 5 No flight director with Century IIB
- 6 No flight director with Century IIB
- 7 Remove wire from Computer AMP pin N or relay and install new pin/wire or cut wire and splice on new wire. Run new wire from AMP pin N or relay to EA100 P2-41.
- 8 The old wire that was going to Computer AMP pin N or relay will need to be lengthened (by splicing) and run to EA100 P2-39.

**Figure E15: EA100 to Century IIB Attitude Source w/DISC**

**NOTE - The EA100 must be configured using the EA100 Tool, See Section E5.8 in this document.**

**GENERAL INSTALLATION NOTES**

All wires in this section 22AWG unless otherwise specified  
 All grounds should be as short as possible  
 Terminate all shields within connector back shell

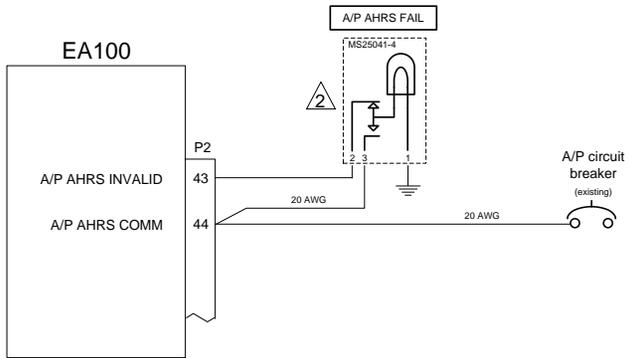

- 1 The existing autopilot disconnect circuit must be run through an internal relay within the EA100. This ensures the autopilot cannot be engaged or will disengage if the EA100 attitude is invalid. The autopilot "sonalert" or disconnect tone must not be interrupted with this relay. Wire as shown.
- 2 A/P AHRS FAIL light must be installed in the pilots primary field of view. Use light/dimmer/test switch P/N MS25041-4. Wire as shown. Use 14v or 28v bulb as appropriate.
- 3 TR2 Transformer/Relay Interface box must be field fabricated using the instructions in this Appendix.
- 4 No flight director with Century III
- 5 No flight director with Century III
- 6 No flight director with Century III
- 7 Remove wire from CD76-B "Relay Box" and install new pin/wire or cut wire and splice on new wire. Run new wire from CD76-B to EA100 P2-41.
- 8 The old wire that was going to CD76-B (from CD27 of 30D207-x) will need to be lengthened (by splicing) and run to EA100 P2-39.

**Before**  
 Trim Enable/Ap Disc and Century Relay Box (partial)

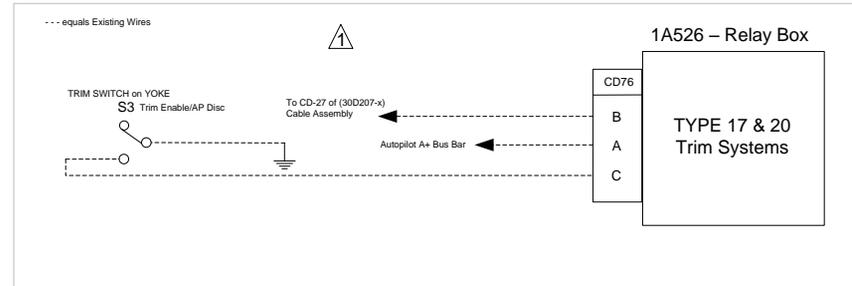

**After**

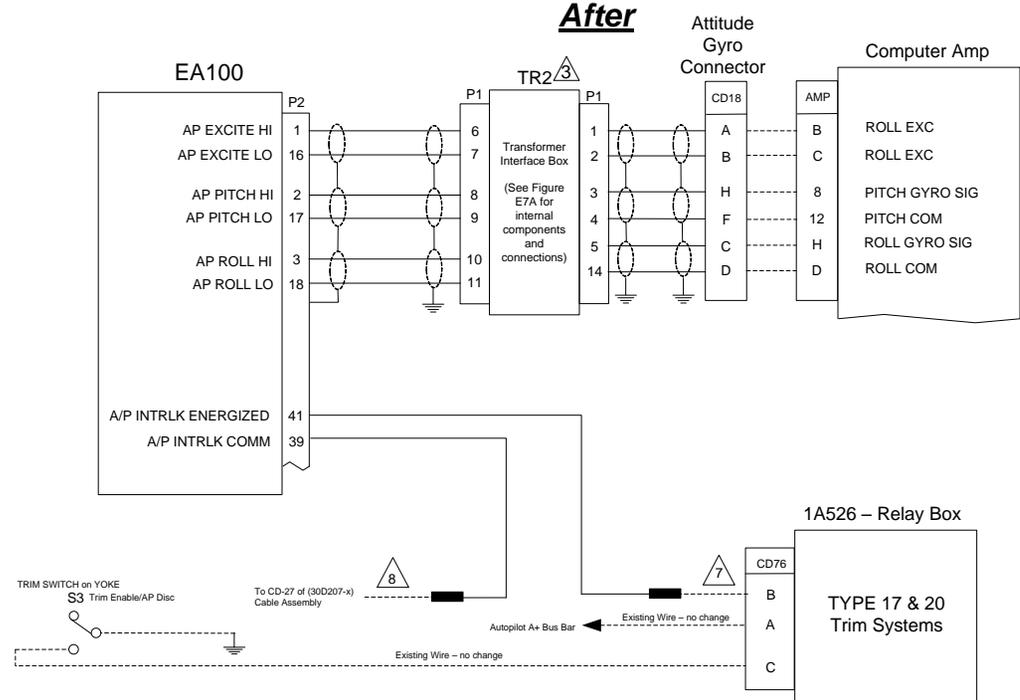
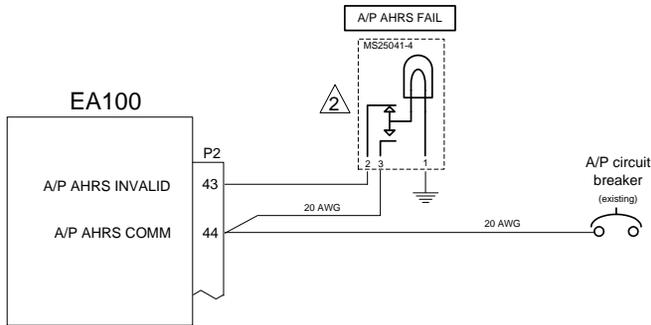

**Figure E16: EA100 to Century III Attitude Source w/DISC**

**NOTE - The EA100 must be configured using the EA100 Tool, See Section E5.8 in this document.**

**GENERAL INSTALLATION NOTES**

All wires in this section 22AWG unless otherwise specified  
 All grounds should be as short as possible  
 Terminate all shields within connector back shell



**Before**  
 A/P DISC Switch OR Century Relay Box (partial)

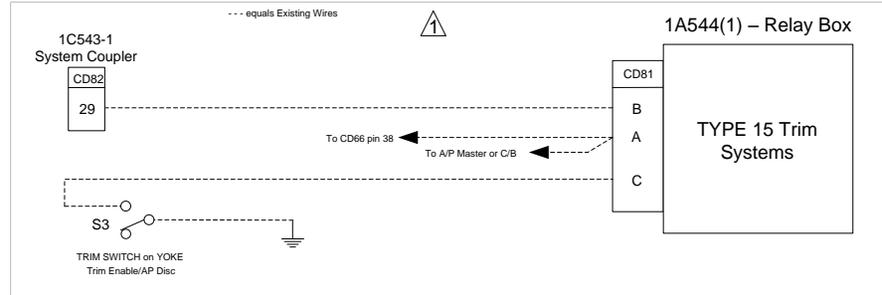

**After**

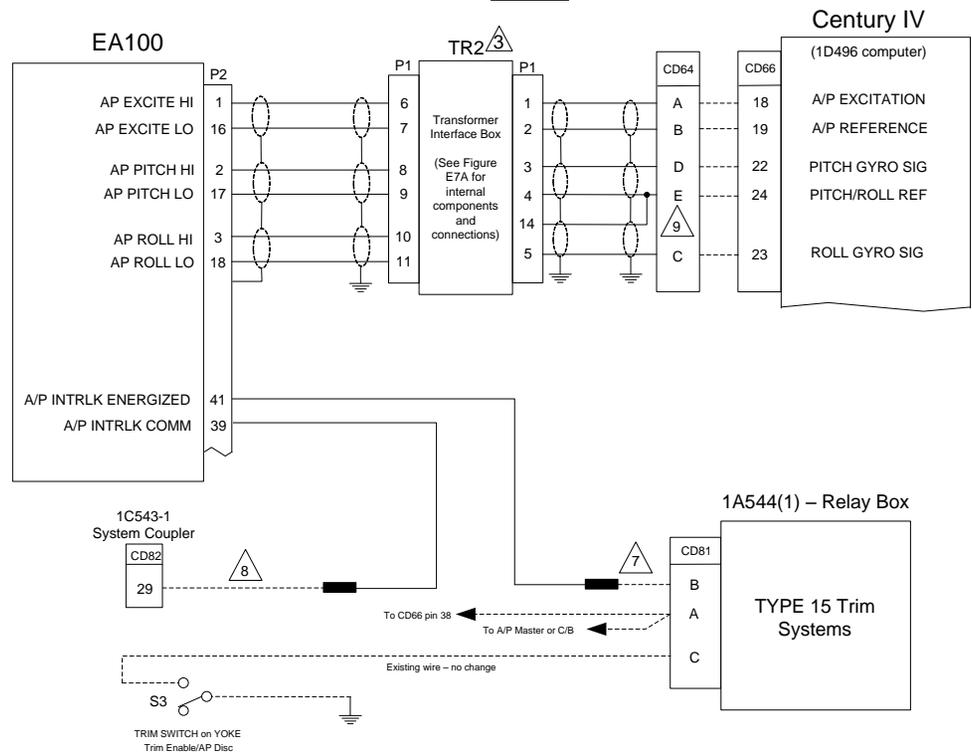

- 1 The existing autopilot disconnect circuit must be run through an internal relay within the EA100. This ensures the autopilot cannot be engaged or will disengage if the EA100 attitude is invalid. The autopilot "sonalert" or disconnect tone must not be interrupted with this relay. Wire as shown.
- 2 A/P AHRS FAIL light must be installed in the pilots primary field of view. Use light/dimmer/test switch P/N MS25041-4. Wire as shown. Use 14v or 28v bulb as appropriate.
- 3 TR2 Transformer Interface box must be field fabricated using the instructions in this Appendix.
- 4 This note is not used
- 5 This note is not used
- 6 This note is not used
- 7 Remove wire from CD81-B (1A544 Relay Box) and install new pin/wire or cut wire and splice on new wire. Run new wire from CD81-B to EA100 P2-41.
- 8 The old wire that was going to CD81-B (from CD82-29) will need to be lengthened and run to EA100 P2-39 or install new pin/wire in CD82-29 and run new wire to EA100 P2-39.
- 9 The tie point of the transformer low wiring coming from pins 4 & 14 of TR2 should be as close to the autopilot computer as possible to eliminate any pitch/roll interaction..

**Figure E17: EA100 to Century IV Attitude Source w/DISC**

**GENERAL INSTALLATION NOTES**

All wires in this section 22AWG unless otherwise specified  
 All grounds should be as short as possible  
 Terminate all shields within connector back shell

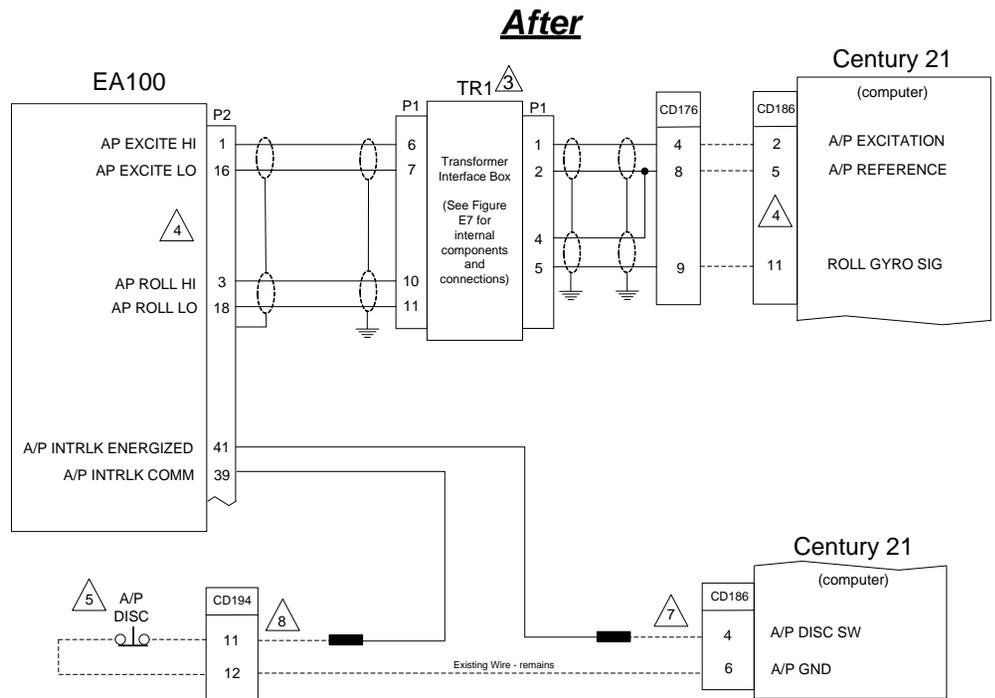
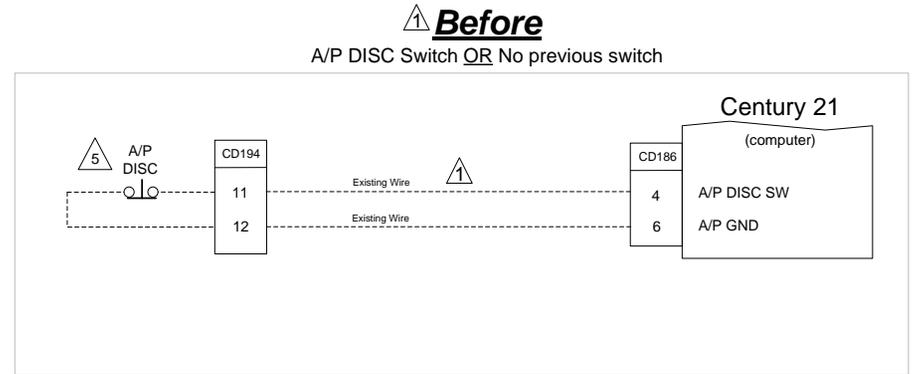
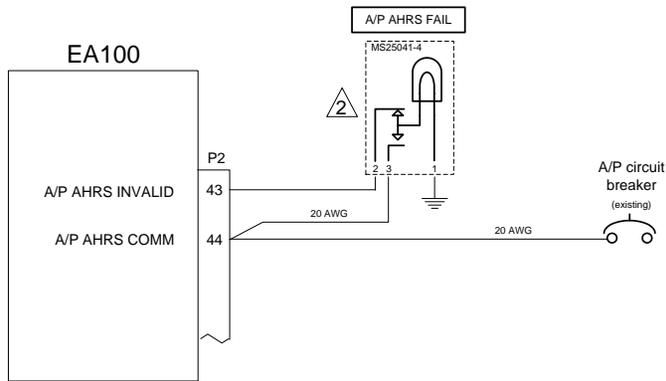

- 1 The existing autopilot disconnect circuit must be run through an internal relay within the EA100. This ensures the autopilot cannot be engaged or will disengage if the EA100 attitude is invalid. The autopilot "sonalert" or disconnect tone must not be interrupted with this relay. Wire as shown.
- 2 A/P AHRS FAIL light must be installed in the pilots primary field of view. Use light/dimmer/test switch P/N MS25041-4. Wire as shown. Use 14v or 28v bulb as appropriate.
- 3 TR1 Transformer/Relay Interface box must be field fabricated using the instructions in this Appendix.
- 4 Century 21 does not have a pitch input as it is single axis only.
- 5 A/P Disconnect switch was optional. If the switch does not exist then pins 11 and 12 are jumpered together in place of the switch. Leave jumper in place and modify wiring as shown.
- 6 No flight director with Century 21
- 7 Remove wire from CD186-4 and install new pin/wire or cut wire and splice on new wire. Run new wire from CD186-4 to EA100 P2-41.
- 8 The old wire that was going to CD186-4 (from CD194-11) will need to be lengthened and run to EA100 P2-39 or install new pin/wire in CD194-11 and run new wire to EA100 P2-39.

Figure E18: EA100 to Century 21 Attitude Source w/DISC

**GENERAL INSTALLATION NOTES**

All wires in this section 22AWG unless otherwise specified  
 All grounds should be as short as possible  
 Terminate all shields within connector back shell

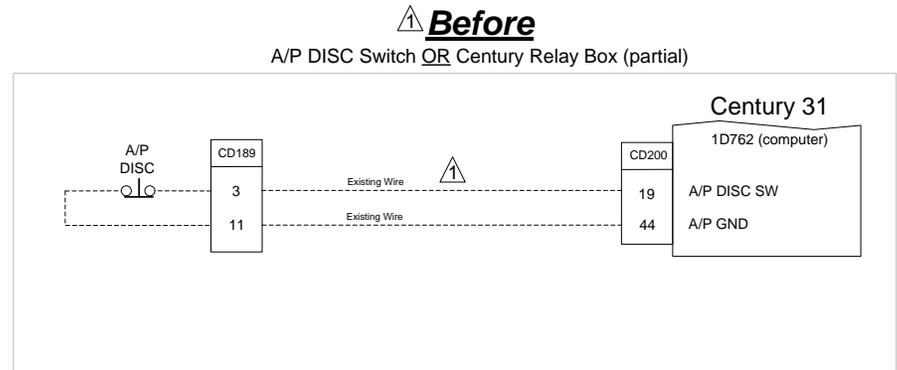
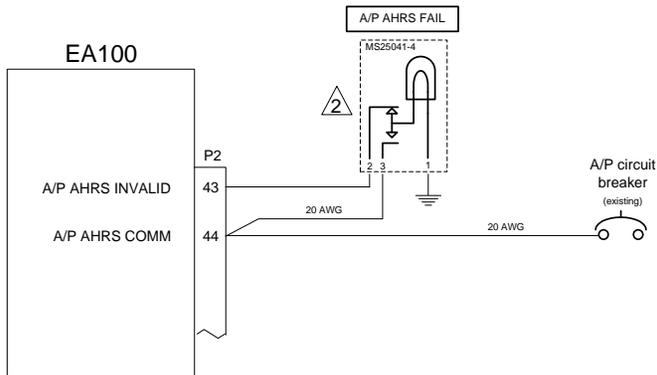

- 1 The existing autopilot disconnect circuit must be run through an internal relay within the EA100. This ensures the autopilot cannot be engaged or will disengage if the EA100 attitude is invalid. The autopilot "sonalert" or disconnect tone must not be interrupted with this relay. Wire as shown.
- 2 A/P AHRs FAIL light must be installed in the pilots primary field of view. Use light/dimmer/test switch P/N MS25041-4. Wire as shown. Use 14v or 28v bulb as appropriate.
- 3 TR1 Transformer/Relay Interface box must be field fabricated using the instructions in this Appendix.
- 4 No flight director with Century 31
- 5 No flight director with Century 31
- 6 No flight director with Century 31
- 7 Remove wire from CD200-19 and install new pin/wire or cut wire and splice on new wire. Run new wire from CD200-19 to EA100 P2-41.
- 8 The old wire that was going to CD200-19 (from CD189-3) will need to be lengthened and run to EA100 P2-39 or install new pin/wire in CD189-3 and run new wire to EA100 P2-39.

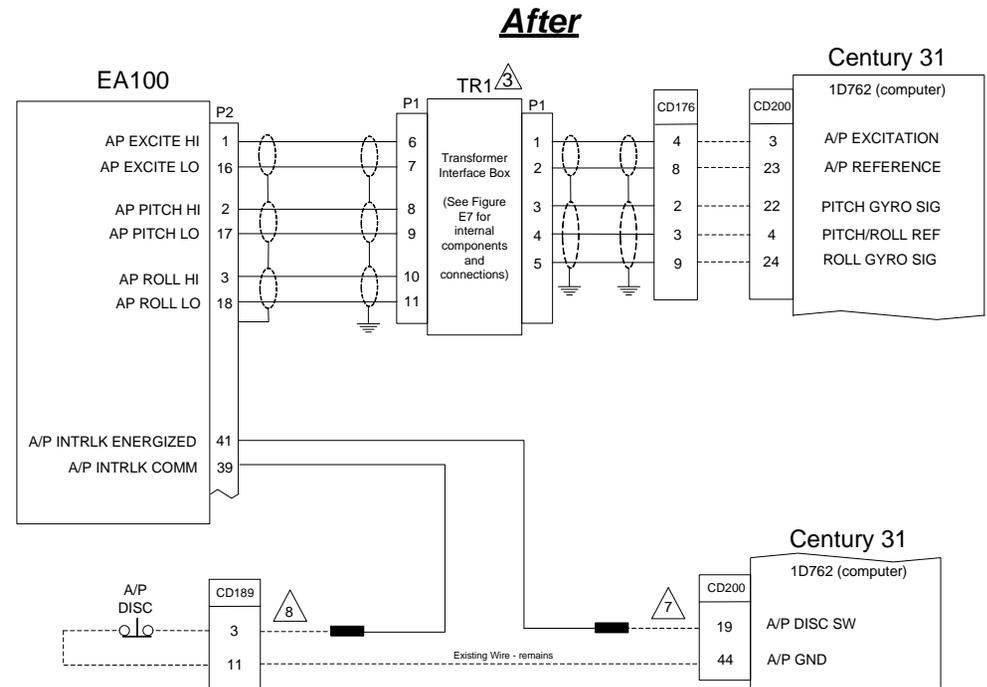
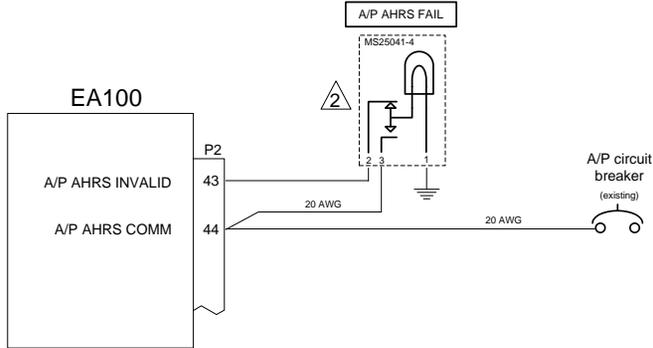

Figure E19: EA100 to Century 31 Attitude Source w/DISC

**GENERAL INSTALLATION NOTES**

All wires in this section 22AWG unless otherwise specified  
 All grounds should be as short as possible  
 Terminate all shields within connector back shell



**Before**  
 A/P DISC Switch OR Century Relay Box (partial)

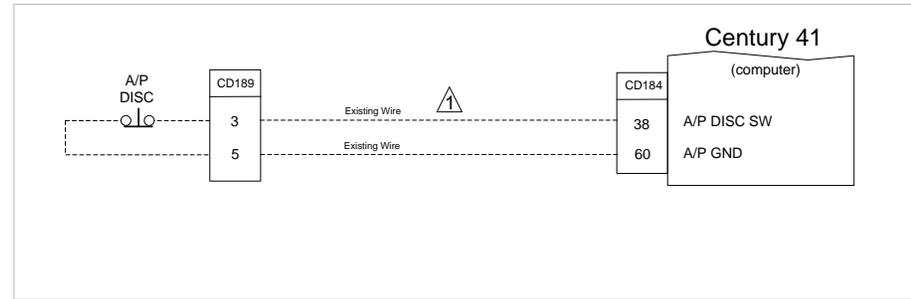

**After**

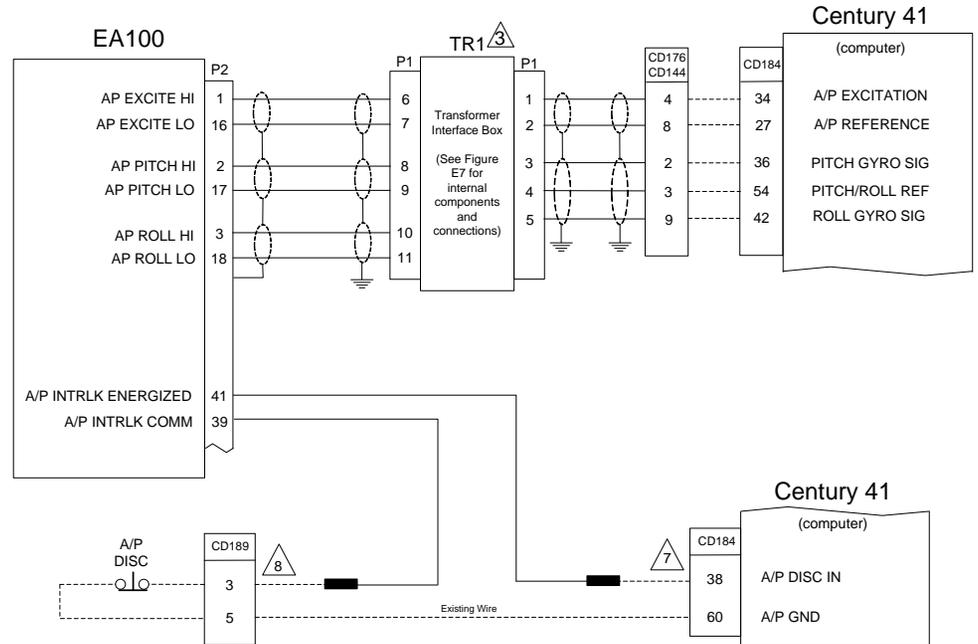

- 1 The existing autopilot disconnect circuit must be run through an internal relay within the EA100. This ensures the autopilot cannot be engaged or will disengage if the EA100 attitude is invalid. The autopilot "sonalert" or disconnect tone must not be interrupted with this relay. Wire as shown.
- 2 A/P AHRS FAIL light must be installed in the pilots primary field of view. Use light/dimmer/test switch P/N MS25041-4. Wire as shown. Use 14v or 28v bulb as appropriate.
- 3 TR1 Transformer Interface box must be field fabricated using the instructions in this Appendix.
- 4 This note not used
- 5 This note is not used
- 6 This note is not used
- 7 Remove wire from CD184-38 and install new pin/wire or cut wire and splice on new wire. Run new wire from CD184-38 to EA100 P2-41.
- 8 The old wire that was going to CD184-38 (from CD189-3) will need to be lengthened and run to EA100 P2-39 or install new pin/wire in CD189-3 and run new wire to EA100 P2-39.

**Figure E20: EA100 to Century 41 Attitude Source w/DISC**

**GENERAL INSTALLATION NOTES**

All wires in this section 22AWG unless otherwise specified  
 All grounds should be as short as possible  
 Terminate all shields within connector back shell

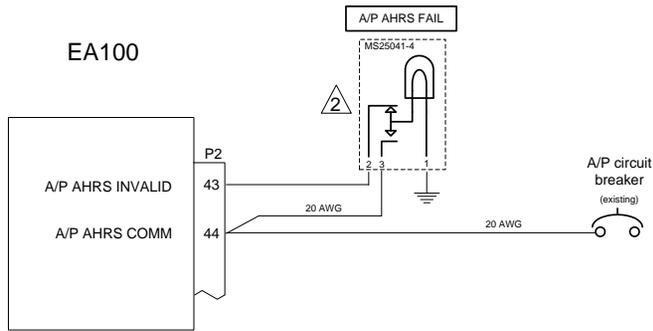

- 1 The existing autopilot disconnect circuit must be run through an internal relay within the EA100. This ensures the autopilot cannot be engaged or will disengage if the EA100 attitude is invalid. The autopilot "sonalert" or disconnect tone must not be interrupted with this relay. Wire as shown.
- 2 A/P AHRs FAIL light must be installed in the pilots primary field of view. Use light/dimmer/test switch P/N MS25041-4. Wire as shown. Use 14v or 28v bulb as appropriate.
- 3 TR1 Transformer Interface box must be field fabricated using the instructions in this Appendix.
- 4 This note is not used
- 5 This note is not used
- 6 This note is not used
- 7 Remove wire from CD221-9 and install new pin/wire or cut wire and splice on new wire. Run new wire from CD221-9 to EA100 P2-41.
- 8 The old wire that was going to CD221-9 (from CD189-3) will need to be lengthened and run to EA100 P2-39 or install new pin/wire in CD189-3 and run new wire to EA100 P2-39.

**Before**  
 A/P DISC Switch OR Century Relay Box (partial)

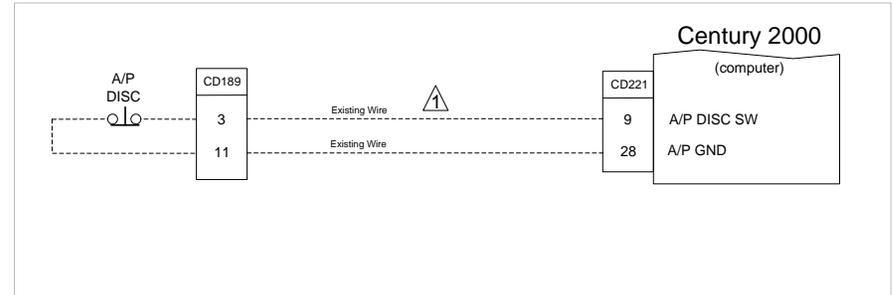

**After**

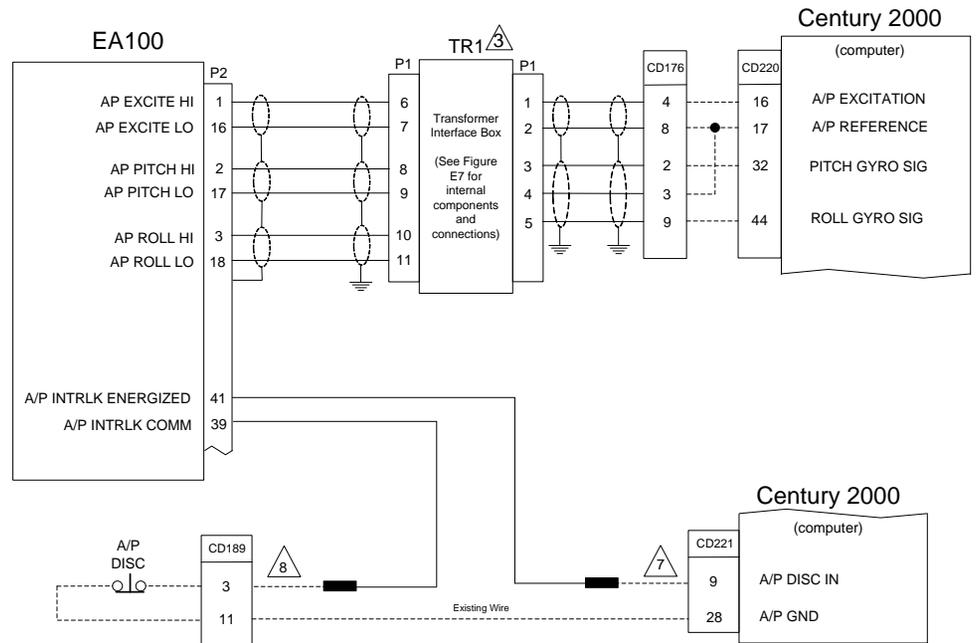

**Figure E21: EA100 to Century 2000 Attitude Source w/DISC**

**GENERAL INSTALLATION NOTES**

All wires in this section 22AWG unless otherwise specified  
 All grounds should be as short as possible  
 Terminate all shields within connector back shell

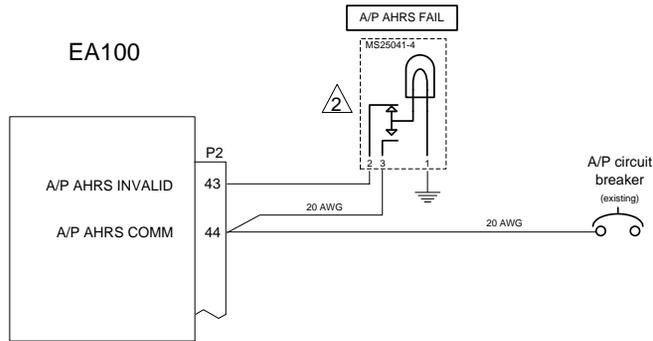

- 1 The existing autopilot disconnect circuit must be run through an internal relay within the EA100. This ensures the autopilot cannot be engaged or will disengage if the EA100 attitude is invalid. The autopilot "sonalert" or disconnect tone must not be interrupted with this relay. Wire as shown.
- 2 A/P AHRS FAIL light must be installed in the pilots primary field of view. Use light/dimmer/test switch P/N MS25041-4. Wire as shown. Use 14v or 28v bulb as appropriate.
- 3 TR1 Transformer Interface box must be field fabricated using the instructions in this Appendix.
- 4 This note is not used
- 5 This note is not used
- 6 This note is not used
- 7 Remove wire from CD280-4 and install new pin/wire or cut wire and splice on new wire. Run new wire from CD280-4 to EA100 P2-41.
- 8 The old wire that was going to CD280-4 (from CD189-3) will need to be lengthened and run to EA100 P2-39 or install new pin/wire in CD189-3 and run new wire to EA100 P2-39.

**Before**  
 A/P DISC Switch OR Century Relay Box (partial)

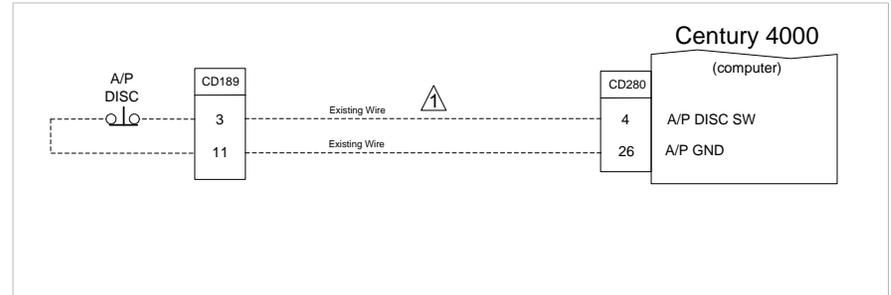

**After**

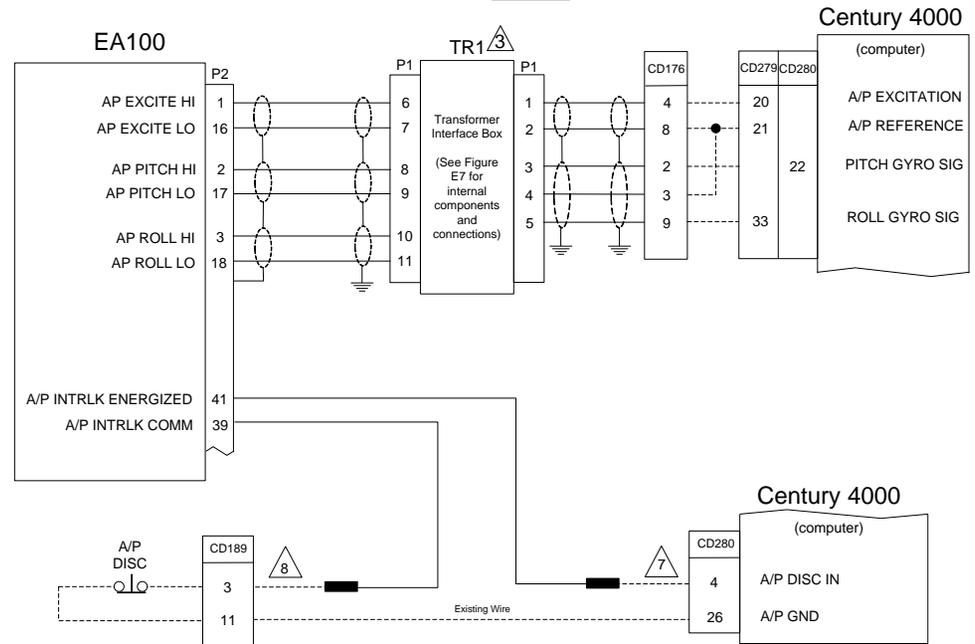

**Figure E22: EA100 to Century 4000 Attitude Source w/DISC**

### E5.8 Configuration

Use Tech Note 2010-10 for instructions on using the EA100 Tool to setup and align the EA100.

For all autopilot types set the Autopilot Excitation and Pitch and Roll gains per the table below. Do not set the Autopilot excitation to anything other than what is listed even if the reference voltage is measured as something else. These are the only approved settings under the STC. Pitch and Roll Gain settings can be varied later during autopilot alignment if necessary.

**** Use EA100 Tool Rev D or Later and make settings below ****					
Autopilot Type	Autopilot Excitation	Pitch Gain UP	Pitch Gain DN	Roll Gain RT	Roll Gain LT
Bendix King	10.00V	50mV	50mV	50mV	50mV
Century 21/31/41 2000/4000	10.00V	50mV	50mV	50mV	50mV
Century IIB/III/IV	2.90Vp-p <small>*(as measured between TR2 pins 6 and 7)</small>	63mV	63mV	65mV	65mV

*\* Note - this voltage is after the resistor divider network. Century A/P excitation is 28Vp-p before network. Use 2.90 as the setting for all Century IIB, III, and IV autopilots regardless of what is measured. Voltage is noted for troubleshooting purposes and should be 2.90 Vp-p +/- 0.3V.*

### EFD1000 E5 Configuration

On the EFD1000 E5 “Network Page” (the second to the last Installation Menu page) set the IP ADDR, SUBNET MASK and PORT as follows:

IP ADDR = 192.168.28.12  
 SUBNET MASK = 255.255.255.0  
 GATEWAY = 0  
 PORT= 8550

To change the IP ADDR press the line select key next to IP ADDR and then rotate the right knob to set the first three digits. Press the line select key again next to IP ADDR to advance the cursor to the next field to the right and set the next three digits. Continue with this sequence until all digits of the IP ADDR are set to 192.168.28.12.

Using Section 10.4.7 verify and set if necessary, the “PANEL ROLL ADJUST” and the “PANEL TILT PITCH ADJ” so that the roll attitude and pitch attitude are 0.0° on the EFD1000 E5 when the aircraft is level.

### E5.9 EA100 Ground Test Procedure

Complete the ground tests in this section as well as the EA100 specific items in Appendix B, EFD1000 E5 Installation Final Check Sheet.

Century Autopilots only – pitch and roll the display by hand or use the EA100 tool to verify the transformer junction box outputs are correct per Table below. This test will verify if the transformer wiring and the settings are correct. It is recommended to use an oscilloscope to measure the outputs as a DVM does not give reliable readings at 5khz. A ground test of the autopilot bank angle limit in HDG mode should also verify proper wiring of at least the reference and roll circuits. About 20 degrees is standard.

Century Autopilot Type	Pitch Output at 10° (measure at TR1 or TR2 pin 3)	Roll Output at 20° (measure at TR1 or TR2 pin 5)
21/31/41/2000/4000	60mV +/- 20mV	60mV +/- 20mV
IIB/III/IV	0.60Vp-p +/- 50mV	1.30Vp-p +/-50mV

**CAUTION:** *If the outputs are not within range of the values in this table then inspect the TR box wiring and settings to correct the issue.*

**All Autopilots**

Power up the EFD. Close the AP AHRS circuit breaker. Power up the autopilot.

- a) Verify the AP AHRS FAIL light extinguishes.
- b) Press Menu on the EFD and then press the AHRS RESET button twice on the EFD. Verify the AP AHRS FAIL light turns on and then goes back out after the AHRS resets.
- c) Engage the autopilot.
- d) Press the autopilot disconnect switch momentarily and verify the autopilot disengages.
- e) Engage the autopilot.
- f) Pull the A/P AHRS circuit breaker and verify the autopilot disengages. Verify the AP AHRS FAIL light on the instrument panel illuminates.
- g) Verify the autopilot cannot be engaged as long as the A/P AHRS FAIL light is illuminated.
- h) Push in the A/P AHRS circuit breaker and after the A/P AHRS FAIL light goes out. Verify that the autopilot can be re-engaged.
- i) Press the A/P AHRS FAIL light “press-to-test” switch and verify the lamp illuminates.

Using the EA100 Tool (see Tech Note 2010-10) or by pitching/rolling the EFD1000 connected to the EA100, perform the following tests with the autopilot engaged in ATT Hold mode. For Century autopilots the default mode will be HDG mode.

**NOTE**

*When the EA100 Tool is running the A/P Engage relay and the A/P AHRS FAIL light relay are not engaged. These must be engaged using the tool to extinguish the light and to be able to engage the autopilot.*

Positive numbers are Roll right and Pitch Up. Negative numbers are Roll left and Pitch down.

- a) Generate a +5° right bank – verify the yoke moves counter-clockwise or **left**.
- b) Generate a –5° left bank – verify the yoke moves clockwise or **right**.
- c) Generate a +5° pitch up – verify the yoke moves **forward**.
- d) Generate a –5° pitch down – verify the yoke moves **back**.

**CAUTION:** *If the yoke moves the wrong direction then inspect the TR box for a wiring error. If it is wired per the drawing but still the pitch or roll is backwards then it is acceptable to reverse the wires inside the TR box at pins 8 & 9 for pitch or pins 10 & 11 for roll.*

## E5.9 Autopilot Gyro Alignment

### NOTE

*The appropriate autopilot test equipment and certifications will be required for this work.*

See Tech Note 2010–10 for instructions on using the EA100 Alignment Tool and the autopilot manufacturer’s alignment procedure to make these adjustments.

### Bendix King Autopilots

Align the EA100 Adapter to the autopilot computer using a KTS–150 Test Set, a KTS–158 Test Set, a KTS–154 Test Set or other appropriate autopilot test set, and following the autopilot manufacturer’s procedure for aligning the gyro to the autopilot computer. The EA100 Alignment Tool will be used to manipulate the gyro pitch and roll signals and the autopilot Test Set or break out box will be used to measure the autopilot gyro voltages. In the case of the KFC225 the Remote Terminal Interface will be required in place of the test sets.

### Century Autopilots

Set the Roll Bank limits in flight per the Century Flight Systems instructions.

## E5.10 Ground EMI Test

### Perform the EMI test in Section 10.6.13 **5.11 Flight Test (Operational Check)**

For new EFD1000 system installations that include the EA100 it is recommended to perform the “Pre EA100 Operational Check” below. After installation of the EA100 perform the “Post EA100 Operational Check” below.

The autopilot should have similar flight performance before and after the EA100 Adapter installation.

#### NOTE

*Any “Pre EA100 Operational Check” performance issues should be resolved prior to the EA100 installation.*

#### *Pre-installation Operational Check*

- a) Under VFR conditions fly the aircraft to a safe maneuvering altitude. Level and trim the aircraft for coordinated flight. Perform all tests (except the approaches) at cruise speed.
- b) Engage the autopilot in pitch and roll mode (Attitude Mode) and verify the aircraft produces no oscillations.
- c) Engage HDG and ALT mode and verify the aircraft will fly the HDG bug within 3 degrees of the lubber line and there are no oscillations.
- d) Turn the HDG bug 90 degrees left. During the turn record the maximum bank angle. Verify the aircraft does not lose more than 100ft during the turn. Verify the autopilot rolls out on the HDG bug with little overshoot.
- e) Turn the HDG Bug 90 degrees right. During the turn record the maximum bank angle. Verify the aircraft does not lose more than 100ft during the turn. Verify the autopilot rolls out on the HDG bug with little overshoot.
- f) If it applies, rotate the autopilot Roll knob left and right and verify the bank angles meet the autopilot manufacturer’s specifications.
- g) Using the Pitch Modifier (pitch rocker switch) press the “up” side of the switch to initiate a climb attitude of about 5 degrees. Verify the aircraft climbs and maintains a consistent 5-degree +/- 2-degree attitude with no oscillations.
- h) Using the Pitch Modifier (pitch rocker switch) press the “down” side of the switch to initiate a descent attitude of about 5 degrees. Verify the aircraft descends and maintains a consistent 5-degree +/- 2-degree attitude with no oscillations.
- i) Perform an ILS approach and note the performance in the lateral and vertical (if Glide Slope equipped) axes.
- j) Should the autopilot fail any of the tests it is recommended that the autopilot be serviced prior to installing the EA100 Adapter.

**Post EA100 Installation Operational Check****NOTE**

*Autopilot adjustment in accordance with the autopilot manufacturer's instructions may be necessary to correct HDG Bug out of center or aircraft tracking off course conditions. The "roll centering pot" adjuster tool should be available. For best results, determine the location of the roll centering pot prior to the Operational Check so that it may be accessed if needed.*

- a) Under VFR conditions fly the aircraft to a safe maneuvering altitude. Level and trim the aircraft for coordinated flight. Perform all tests (except the approaches) at cruise speed.
- b) Engage the autopilot in pitch and roll mode (Attitude Mode or HDG mode for the Century) and verify the aircraft produces no oscillations.
- c) Engage HDG and ALT mode and verify the HDG bug centers under the lubber line. If the HDG bug is not under the lubber line verify the slip/skid indicator is centered. If the slip/skid indicator is centered then the autopilot roll null "roll centering" is out of adjustment. If the slip/skid indicator is out of center then adjust rudder trim to center.
- d) Turn the HDG bug 90 degrees left. During the turn record the maximum bank angle. Verify the aircraft does not lose more than 100ft during the turn. Verify the autopilot rolls out on the HDG bug with little overshoot.
- e) Turn the HDG Bug 90 degrees right. During the turn record the maximum bank angle. Verify the aircraft does not lose more than 100ft during the turn. Verify the autopilot rolls out on the HDG bug with little overshoot.
- f) If it applies, rotate the autopilot Roll knob left and right and verify the bank angle are within 2 degrees of the pre EA100 Operational Check.
- g) Using the Pitch Modifier (pitch rocker switch) press the "up" side of the switch to initiate a climb attitude of about 5 degrees. Verify the aircraft climbs and maintains a consistent 5-degree +/- 2-degree attitude with no oscillations.
- h) Using the Pitch Modifier (pitch rocker switch) press the "down" side of the switch to initiate a descent attitude of about 5 degrees. Verify the aircraft descends and maintains a consistent 5-degree +/- 2-degree attitude with no oscillations.
- i) Perform an ILS approach and note the performance in the lateral and vertical (if Glide Slope equipped) axes. Verify no oscillations.
- j) If the autopilot performance is similar to or better than that of the pre-install Operational Check (and the pre-install Operational Check was satisfactory) then no further adjustments are necessary. If the HDG bug did not center use the "roll centering" pot to correct this condition. If the maximum bank angles or pitch angles were outside the maximum allowed by the autopilot manufacturer then the autopilot must be aligned to the EA100 using the manufacturer's gyro alignment procedure.

**NOTE**

*If the Operational Check revealed a fast pump of the yoke in pitch of approximately 1 second per cycle then use Tech Note TN2013-02 and set the "PITCH SCALE" from 0.5 to 0.0*

This Page is to be printed and given to the aircraft owner for inclusion in the aircraft records.

<b>AUTOPILOT “PRE” AND “POST” EA100 OPERATIONAL CHECK</b>			
AIRCRAFT TYPE:		AIRCRAFT REG#:	
AIRCRAFT S/N:		AUTOPILOT MODEL:	
A/P MODE	PARAMETERS	PRE EA100 INSTALL	POST EA100 INSTALL
HDG ALT	HDG Bug from Lubber Line -Oscillations?		
HDG ALT	Maximum Left Bank Angle		
HDG ALT	Maximum Right Bank Angle		
ATT ALT	Maximum Left Bank Angle with Roll Knob (if applicable)		
ATT ALT	Maximum Right Bank Angle with Roll Knob (if applicable)		
HDG ALT	ALT HOLD mode (does it hold aircraft within 100ft during turns)		
HDG ATT	5 Degree Pitch Up -Oscillations?		
HDG ATT	5 Degree Pitch Down -Oscillations?		
APPR	ILS lateral Performance -Oscillations?		
APPR	Glide Slope Performance -Oscillations?		
NOTES: Century A/P – ATT means Roll and Pitch switches on, no HDG.			

Record the EA100 Final configuration in the table below

	Autopilot	Wx Radar
Gain Up	mV/°	mV/°
Gain Dn	mV/°	mV/°
Gain Rt	mV/°	mV/°
Gain Lt	mV/°	mV/°
Pitch Offset	mV/°	mV/°
Roll Offset	mV/°	mV/°
Autopilot Excitation	Volts	Volts

### Environmental Qualification Form

Nomenclature..... EA100 Adapter  
 Part Number..... 910-00013-001  
 TSO Numbers ..... TSO-C4c, TSO-C113  
 Manufacturer..... Aspen Avionics, Inc.  
 Address..... 5001 Indian School Road NE, Albuquerque, NM 87110  
 DO-160 Revision..... DO-160E  
 Date tested..... 7/2010

Condition	Section	Description of Tests Conducted
Temperature and Altitude	4.0	Equipment tested to Category D1
Low Temperature	4.5.1	
High Temperature	4.5.2 & 4.5.3	
Altitude	4.6.1	
Decompression	4.6.2	
Overpressure	4.6.3	
Temperature Variation	5.0	Equipment tested to Category B
Humidity	6.0	Equipment tested to Category A
Operational Shocks and Crash Safety	7.0	Equipment tested to Category B
Vibration (Fixed Wing)	8.0	Equipment tested to Category S, aircraft Zone 2 for Fixed Wing Reciprocating & Turboprop Engines, Multi Eng over 5700 KG (12,500 lbs.) (Using curve M), Multi Eng Less than 5700 KG (12,500 lbs.) (Using curve M), Single Eng Less than 5700 KG (12,500 lbs.) (using curve M)
Explosive Atmosphere	9.0	Equipment identified as Category X, no test performed
Waterproofness	10.0	Equipment identified as Category X, no test performed
Fluids Susceptibility	11.0	Equipment identified as Category X, no test performed
Sand and Dust	12.0	Equipment identified as Category X, no test performed
Fungus	13.0	Equipment identified as Category X, no test performed
Salt Fog Test	14.0	Equipment identified as Category X, no test performed
Magnetic Effect	15.0	Equipment is Category Z
Power Input	16.0	Equipment tested to Category B
Voltage Spike	17.0	Equipment tested to Category A
Audio Freq Conducted Susceptibility	18.0	Equipment tested to Category B
Induced Signal Susceptibility	19.0	Equipment tested to Category ZC
Radio Frequency Susceptibility	20.0	Equipment tested to Category TT
Radio Frequency Emission	21.0	Equipment tested to Category M, significant EM apertures, not in direct view of radio receiver antenna (Equipment mounted in cockpit or cabin area)
Lighting Induced Transient Susceptibility	22.0	Equipment tested to Category B3K33, Waveform Sets B and K are applicable for equipment interconnected with wiring installed within any airframe or airframe section when structural resistance is also a significant source of induced transients, (i.e. carbon fiber composite structures). Level 3 is intended for equipment and interconnecting wiring installed in a moderately exposed environment.
Lightning Direct Effects	23.0	Equipment identified as Category X, no test performed
Icing	24.0	Equipment identified as Category X, no test performed
Electrostatic Discharge	25.0	Equipment tested to Category A
Fire, Flammability	26.0	Equipment identified as Category X, no test performed
Other Tests		Fire resistance conducted by analysis in accordance with Federal Aviation Regulations Part 25, Appendix F.

Section 22.5.1 (Pin Injection): Communication between the EA100 and EFD1000 stopped. The EFD1000 remained operational, and the EA100 successfully disengaged the autopilot relays.

END