

Airflex® General Engineering Data

Section Z

Inertia and Radius of Gyration	352
Weight and Wk^2 for Steel Cylinders	353
Formulas for Geometric Solids	366
Motor Armature Wk^2	370
Wk^2 for Standard Sheaves	371
V-Belt Dimensions	373
Torque vs. Shaft Stress	374
Shaft Key Standards	375
Motor Torque-Speed Characteristics	377
Electric Motor Frames	377
Motor Frame Dimensions	378
Air Compressor Requirements	380
Steel Pipe Data	381
Temperature Comparison	382
Steel Wire and Sheet Gage Numbers	383
Airflex 2-Year Warranty	384

Airflex® Inertia and Radius of Gyration

Section Z

Moment of inertia of a body is determined by the distribution of its mass about an axis of rotation.

The radius of gyration of a body is the distance from its axis of rotation to a point at which its mass can be concentrated without changing its moment of inertia.

The moment of inertia J of a body with a mass m and radius of gyration k is:

$$J = m \cdot k^2$$

(All units are as given in the Table of Units and Measure)

In the English system, mass is equal to the body weight W in pounds divided by the gravitational constant g (32.2 ft/sec²), so that the expression can be written as:

$$J = \frac{W \cdot k^2}{g}$$

In most formulas g is included in one general constant, so that Wk^2 itself remains as a convenient expression. Most formulas require that Wk^2 have units of lb · ft².

The moment of inertia of a body is usually referred to an axis passing through its center of gravity. It is often necessary to refer the moment of inertia to another parallel axis. The transfer formula is:

$$J_{xx} = J_{gg} + m \cdot r^2$$

where:

J_{gg} is the moment of inertia about an axis through the center of mass.

m is the mass.

Example:

Determine the equivalent Wk^2 of the sliding weight at the motor shaft.

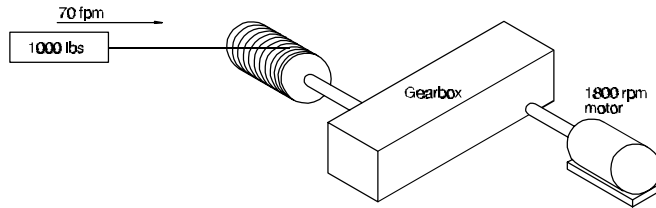

$$Wk^2 = \frac{W}{39.48} \cdot \left(\frac{\text{fpm}}{n} \right)^2$$

$$Wk^2 = \frac{1000}{39.48} \cdot \left(\frac{70}{1800} \right)^2$$

$$Wk^2 = 0.038 \text{ lb} \cdot \text{ft}^2 \quad (0.0016 \text{ kg} \cdot \text{m}^2)$$

r is the perpendicular distance between the two parallel axes.

In like fashion, the following analogous relations exist between the centroidal axis and any parallel axis:

$$Wk^2_{xx} = Wk^2_{gg} + Wr^2$$

$$k^2_{xx} = k^2_{gg} + r^2$$

For referring the moment of inertia from one shaft to another shaft rotating at a different speed, the formula is:

$$J_2 = J_1 \cdot \left(\frac{n_1}{n_2} \right)^2$$

$$Wk_2^2 = Wk_1^2 \cdot \left(\frac{n_1}{n_2} \right)^2$$

The equivalent inertia of a linearly moving body referred to an axis of rotation can be determined by equating its linear kinetic energy to rotary kinetic energy to obtain:

$$J = gI \cdot m \cdot \left(\frac{v}{n} \right)^2$$

$$Wk^2 = \frac{W}{39.48} \cdot \left(\frac{\text{fpm}}{n} \right)^2$$

Weight and Wk^2 values for cylindrical steel discs, one inch thick, appear in the following table. Weight, mass and radius of gyration formulas for common geometric solids are given on the following pages. Examples illustrate the use of these tables and formulas. Other tables

Example:

Determine the equivalent Wk^2 at shaft 2.

$$Wk_2^2 = Wk_1^2 \cdot \left(\frac{n_1}{n_2} \right)^2$$

$$Wk_2^2 = 500 \cdot \left(\frac{600}{100} \right)^2$$

$$Wk_2^2 = 18,000 \text{ lb} \cdot \text{ft}^2 \quad (756 \text{ kg} \cdot \text{m}^2)$$

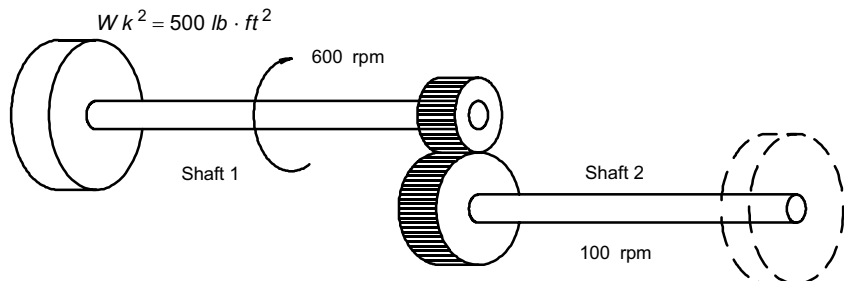

Airflex® Weight and Wk^2 for Steel Cylinders

Section Z

The table below lists the weight (lb) and Wk^2 (lb · ft²) for various diameter steel cylinders one inch long. For other cylinder lengths multiply the table value by the length in inches. To obtain values for diameters not listed, use the following formulas:

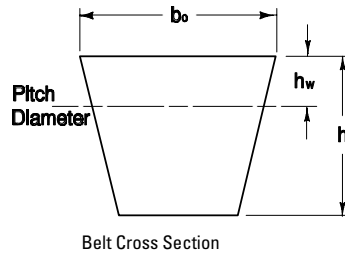

The table is based upon a steel density of 0.283 lb/in³. For other common materials

Material	Factor
Aluminum	0.346
Bronze	1.120
Cast Iron	0.926
Copper	1.113
Lead	1.449



Diameter (in)	Weight (lb)	Wk^2 (lb · ft ²)
1.0	0.222	0.0002
1.1	0.269	0.0003
1.2	0.320	0.0004
1.3	0.376	0.0006
1.4	0.436	0.0007
1.5	0.500	0.0010
1.6	0.569	0.0013
1.7	0.642	0.0016
1.8	0.720	0.0020
1.9	0.802	0.0025
2.0	0.889	0.0031
2.1	0.980	0.0038
2.2	1.076	0.0045
2.3	1.176	0.0054
2.4	1.280	0.0064
2.5	1.389	0.0075
2.6	1.503	0.0088
2.7	1.620	0.0103
2.8	1.743	0.0119
2.9	1.869	0.0136
3.0	2.000	0.0156
3.1	2.136	0.0178
3.2	2.276	0.0202
3.3	2.421	0.0229
3.4	2.569	0.0258
3.5	2.723	0.0290
3.6	2.881	0.0324
3.7	3.043	0.0362
3.8	3.210	0.0402
3.9	3.381	0.0446
4.0	3.556	0.0494
4.1	3.736	0.0545
4.2	3.921	0.0600
4.3	4.110	0.0660
4.4	4.303	0.0723
4.5	4.501	0.0791

Diameter (in)	Weight (lb)	Wk^2 (lb · ft ²)
4.6	4.703	0.0864
4.7	4.910	0.0941
4.8	5.121	0.1024
4.9	5.337	0.1112
5.0	5.557	0.1206
5.1	5.781	0.1305
5.2	6.010	0.1411
5.3	6.244	0.1522
5.4	6.481	0.1640
5.5	6.724	0.1765
5.6	6.970	0.1897
5.7	7.222	0.2037
5.8	7.477	0.2183
5.9	7.737	0.2338
6.0	8.002	0.2500
6.1	8.271	0.2671
6.2	8.544	0.2851
6.3	8.822	0.3039
6.4	9.104	0.3237
6.5	9.391	0.3444
6.6	9.682	0.3661
6.7	9.978	0.3888
6.8	10.28	0.4125
6.9	10.58	0.4373
7.0	10.89	0.4632
7.1	11.20	0.4903
7.2	11.52	0.5185
7.3	11.84	0.5479
7.4	12.17	0.5785
7.5	12.50	0.6104
7.6	12.84	0.6437
7.7	13.18	0.6782
7.8	13.52	0.7141
7.9	13.87	0.7515
8.0	14.23	0.7902
8.1	14.58	0.8305

Diameter (in)	Weight (lb)	Wk^2 (lb · ft ²)
8.2	14.95	0.8723
8.3	15.31	0.9156
8.4	15.68	0.9605
8.5	16.06	1.0071
8.6	16.44	1.0553
8.7	16.82	1.1053
8.8	17.21	1.1570
8.9	17.61	1.2105
9.0	18.00	1.2658
9.1	18.41	1.3230
9.2	18.81	1.3821
9.3	19.22	1.4432
9.4	19.64	1.5063
9.5	20.06	1.5714
9.6	20.48	1.6386
9.7	20.91	1.7080
9.8	21.35	1.7795
9.9	21.78	1.8533
10.0	22.23	1.9293
10.1	22.67	2.0076
10.2	23.12	2.0883
10.3	23.58	2.1714
10.4	24.04	2.2570
10.5	24.51	2.3451
10.6	24.97	2.4357
10.7	25.45	2.5289
10.8	25.93	2.6248
10.9	26.41	2.7234
11.0	26.89	2.8247
11.1	27.39	2.9288
11.2	27.88	3.0358
11.3	28.38	3.1457
11.4	28.89	3.2585
11.5	29.40	3.3744
11.6	29.91	3.4933
11.7	30.43	3.6153

Airflex® Weight and Wk² for Steel Cylinders

Section Z

Diameter (in)	Weight (lb)	Wk ² (lb · ft ²)	Diameter (in)	Weight (lb)	Wk ² (lb · ft ²)	Diameter (in)	Weight (lb)	Wk ² (lb · ft ²)
11.8	30.95	3.7405	17.2	65.76	16.885	22.6	113.5	50.331
11.9	31.48	3.8689	17.3	66.52	17.282	22.7	114.5	51.228
12.0	32.01	4.0006	17.4	67.29	17.685	22.8	115.5	52.136
12.1	32.54	4.1356	17.5	68.07	18.095	22.9	116.6	53.057
12.2	33.08	4.2740	17.6	68.85	18.512	23.0	117.6	53.990
12.3	33.63	4.4159	17.7	69.63	18.936	23.1	118.6	54.935
12.4	34.18	4.5613	17.8	70.42	19.368	23.2	119.6	55.892
12.5	34.73	4.7102	17.9	71.22	19.807	23.3	120.7	56.862
12.6	35.29	4.8628	18.0	72.02	20.253	23.4	121.7	57.845
12.7	35.85	5.0190	18.1	72.82	20.707	23.5	122.7	58.840
12.8	36.42	5.1789	18.2	73.62	21.168	23.6	123.8	59.848
12.9	36.99	5.3427	18.3	74.44	21.637	23.7	124.8	60.869
13.0	37.56	5.5103	18.4	75.25	22.114	23.8	125.9	61.902
13.1	38.14	5.6818	18.5	76.07	22.599	23.9	127.0	62.949
13.2	38.73	5.8573	18.6	76.90	23.091	24.0	128.0	64.010
13.3	39.32	6.0368	18.7	77.73	23.592	24.1	129.1	65.083
13.4	39.91	6.2204	18.8	78.56	24.101	24.2	130.2	66.170
13.5	40.51	6.4082	18.9	79.40	24.618	24.3	131.2	67.271
13.6	41.11	6.6002	19.0	80.24	25.143	24.4	132.3	68.385
13.7	41.72	6.7964	19.1	81.09	25.676	24.5	133.4	69.513
13.8	42.33	6.9971	19.2	81.94	26.218	24.6	134.5	70.655
13.9	42.94	7.2021	19.3	82.79	26.769	24.7	135.6	71.810
14.0	43.56	7.4116	19.4	83.65	27.328	24.8	136.7	72.980
14.1	44.19	7.6256	19.5	84.52	27.896	24.9	137.8	74.165
14.2	44.82	7.8443	19.6	85.39	28.472	25.0	138.9	75.363
14.3	45.45	8.0676	19.7	86.26	29.058	25.1	140.0	76.576
14.4	46.09	8.2956	19.8	87.14	29.652	25.2	141.2	77.804
14.5	46.73	8.5285	19.9	88.02	30.256	25.3	142.3	79.046
14.6	47.38	8.7662	20.0	88.91	30.869	25.4	143.4	80.304
14.7	48.03	9.0088	20.1	89.80	31.491	25.5	144.5	81.576
14.8	48.69	9.2565	20.2	90.70	32.122	25.6	145.7	82.863
14.9	49.35	9.5092	20.3	91.60	32.763	25.7	146.8	84.165
15.0	50.01	9.7671	20.4	92.50	33.413	25.8	148.0	85.483
15.1	50.68	10.030	20.5	93.41	34.073	25.9	149.1	86.816
15.2	51.35	10.299	20.6	94.32	34.743	26.0	150.3	88.164
15.3	52.03	10.572	20.7	95.24	35.423	26.1	151.4	89.529
15.4	52.71	10.851	20.8	96.16	36.112	26.2	152.6	90.909
15.5	53.40	11.136	20.9	97.09	36.812	26.3	153.7	92.304
15.6	54.09	11.426	21.0	98.02	37.521	26.4	154.9	93.716
15.7	54.79	11.722	21.1	98.96	38.241	26.5	156.1	95.144
15.8	55.49	12.023	21.2	99.90	38.971	26.6	157.3	96.589
15.9	56.19	12.331	21.3	100.8	39.712	26.7	158.5	98.049
16.0	56.90	12.644	21.4	101.8	40.463	26.8	159.6	99.527
16.1	57.61	12.963	21.5	102.7	41.224	26.9	160.8	101.02
16.2	58.33	13.288	21.6	103.7	41.997	27.0	162.0	102.53
16.3	59.05	13.619	21.7	104.7	42.780	27.1	163.2	104.06
16.4	59.78	13.956	21.8	105.6	43.574	27.2	164.4	105.60
16.5	60.51	14.300	21.9	106.6	44.379	27.3	165.7	107.16
16.6	61.25	14.650	22.0	107.6	45.195	27.4	166.9	108.74
16.7	61.99	15.006	22.1	108.6	46.022	27.5	168.1	110.34
16.8	62.73	15.369	22.2	109.5	46.861	27.6	169.3	111.95
16.9	63.48	15.738	22.3	110.5	47.711	27.7	170.5	113.58
17.0	64.24	16.114	22.4	111.5	48.573	27.8	171.8	115.23
17.1	64.99	16.496	22.5	112.5	49.446	27.9	173.0	116.90

Airflex® Weight and Wk² for Steel Cylinders

Section Z

Diameter (in)	Weight (lb)	Wk ² (lb · ft ²)	Diameter (in)	Weight (lb)	Wk ² (lb · ft ²)	Diameter (in)	Weight (lb)	Wk ² (lb · ft ²)
28.0	174.3	118.59	33.4	248.0	240.10	38.8	334.6	437.25
28.1	175.5	120.29	33.5	249.4	242.98	38.9	336.3	441.77
28.2	176.8	122.01	33.6	250.9	245.90	39.0	338.1	446.33
28.3	178.0	123.75	33.7	252.4	248.84	39.1	339.8	450.93
28.4	179.3	125.51	33.8	253.9	251.81	39.2	341.5	455.56
28.5	180.5	127.29	33.9	255.4	254.80	39.3	343.3	460.22
28.6	181.8	129.08	34.0	256.9	257.82	39.4	345.0	464.93
28.7	183.1	130.90	34.1	258.5	260.87	39.5	346.8	469.66
28.8	184.4	132.73	34.2	260.0	263.94	39.6	348.6	474.44
28.9	185.6	134.58	34.3	261.5	267.04	39.7	350.3	479.25
29.0	186.9	136.46	34.4	263.0	270.17	39.8	352.1	484.10
29.1	188.2	138.35	34.5	264.6	273.32	39.9	353.9	488.98
29.2	189.5	140.26	34.6	266.1	276.51	40.0	355.6	493.90
29.3	190.8	142.19	34.7	267.6	279.72	40.1	357.4	498.86
29.4	192.1	144.14	34.8	269.2	282.95	40.2	359.2	503.85
29.5	193.4	146.11	34.9	270.7	286.22	40.3	361.0	508.89
29.6	194.7	148.10	35.0	272.3	289.52	40.4	362.8	513.96
29.7	196.1	150.12	35.1	273.8	292.84	40.5	364.6	519.06
29.8	197.4	152.15	35.2	275.4	296.19	40.6	366.4	524.21
29.9	198.7	154.20	35.3	277.0	299.57	40.7	368.2	529.39
30.0	200.0	156.27	35.4	278.5	302.98	40.8	370.0	534.61
30.1	201.4	158.37	35.5	280.1	306.42	40.9	371.8	539.87
30.2	202.7	160.48	35.6	281.7	309.88	41.0	373.6	545.17
30.3	204.1	162.62	35.7	283.3	313.38	41.1	375.5	550.51
30.4	205.4	164.78	35.8	284.9	316.91	41.2	377.3	555.89
30.5	206.8	166.95	35.9	286.5	320.46	41.3	379.1	561.31
30.6	208.1	169.16	36.0	288.1	324.05	41.4	381.0	566.76
30.7	209.5	171.38	36.1	289.7	327.66	41.5	382.8	572.26
30.8	210.9	173.62	36.2	291.3	331.31	41.6	384.7	577.79
30.9	212.2	175.89	36.3	292.9	334.99	41.7	386.5	583.37
31.0	213.6	178.17	36.4	294.5	338.69	41.8	388.4	588.99
31.1	215.0	180.49	36.5	296.1	342.43	41.9	390.2	594.64
31.2	216.4	182.82	36.6	297.7	346.20	42.0	392.1	600.34
31.3	217.8	185.17	36.7	299.4	350.00	42.1	394.0	606.08
31.4	219.1	187.55	36.8	301.0	353.83	42.2	395.8	611.86
31.5	220.5	189.95	36.9	302.6	357.69	42.3	397.7	617.68
31.6	221.9	192.37	37.0	304.3	361.58	42.4	399.6	623.54
31.7	223.4	194.82	37.1	305.9	365.51	42.5	401.5	629.44
31.8	224.8	197.29	37.2	307.6	369.46	42.6	403.4	635.39
31.9	226.2	199.78	37.3	309.2	373.45	42.7	405.3	641.37
32.0	227.6	202.30	37.4	310.9	377.47	42.8	407.2	647.40
32.1	229.0	204.84	37.5	312.6	381.53	42.9	409.1	653.47
32.2	230.5	207.41	37.6	314.2	385.61	43.0	411.0	659.59
32.3	231.9	210.00	37.7	315.9	389.73	43.1	412.9	665.75
32.4	233.3	212.61	37.8	317.6	393.88	43.2	414.8	671.95
32.5	234.8	215.25	37.9	319.3	398.07	43.3	416.7	678.19
32.6	236.2	217.91	38.0	321.0	402.29	43.4	418.7	684.48
32.7	237.7	220.59	38.1	322.6	406.54	43.5	420.6	690.81
32.8	239.1	223.30	38.2	324.3	410.82	43.6	422.5	697.18
32.9	240.6	226.04	38.3	326.0	415.14	43.7	424.5	703.60
33.0	242.1	228.80	38.4	327.8	419.49	43.8	426.4	710.06
33.1	243.5	231.59	38.5	329.5	423.88	43.9	428.4	716.57
33.2	245.0	234.40	38.6	331.2	428.30	44.0	430.3	723.12
33.3	246.5	237.23	38.7	332.9	432.76	44.1	432.3	729.72

Airflex® Weight and Wk² for Steel Cylinders

Section Z

Diameter (in)	Weight (lb)	Wk ² (lb · ft ²)	Diameter (in)	Weight (lb)	Wk ² (lb · ft ²)	Diameter (in)	Weight (lb)	Wk ² (lb · ft ²)
44.2	434.2	736.36	49.6	546.8	1167.7	60.0	800.2	2500.4
44.3	436.2	743.04	49.7	549.0	1177.1	60.2	805.5	2533.9
44.4	438.2	749.78	49.8	551.2	1186.6	60.4	810.9	2567.7
44.5	440.2	756.55	49.9	553.5	1196.2	60.6	816.3	2601.9
44.6	442.1	763.38	50.0	555.7	1205.8	60.8	821.7	2636.4
44.7	444.1	770.25	50.2	560.1	1225.2	61.0	827.1	2671.3
44.8	446.1	777.16	50.4	564.6	1244.9	61.2	832.5	2706.5
44.9	448.1	784.12	50.6	569.1	1264.7	61.4	837.9	2742.0
45.0	450.1	791.13	50.8	573.6	1284.9	61.6	843.4	2777.9
45.1	452.1	798.19	51.0	578.1	1305.2	61.8	848.9	2814.2
45.2	454.1	805.29	51.2	582.7	1325.8	62.0	854.4	2850.8
45.3	456.1	812.44	51.4	587.2	1346.6	62.2	859.9	2887.8
45.4	458.1	819.64	51.6	591.8	1367.7	62.4	865.5	2925.1
45.5	460.2	826.89	51.8	596.4	1389.1	62.6	871.0	2962.8
45.6	462.2	834.18	52.0	601.0	1410.6	62.8	876.6	3000.8
45.7	464.2	841.52	52.2	605.7	1432.5	63.0	882.2	3039.2
45.8	466.2	848.91	52.4	610.3	1454.5	63.2	887.8	3078.0
45.9	468.3	856.35	52.6	615.0	1476.9	63.4	893.4	3117.1
46.0	470.3	863.84	52.8	619.7	1499.5	63.6	899.1	3156.7
46.1	472.4	871.37	53.0	624.4	1522.3	63.8	904.7	3196.6
46.2	474.4	878.96	53.2	629.1	1545.4	64.0	910.4	3236.8
46.3	476.5	886.59	53.4	633.8	1568.8	64.2	916.1	3277.5
46.4	478.5	894.28	53.6	638.6	1592.4	64.4	921.8	3318.5
46.5	480.6	902.01	53.8	643.3	1616.3	64.6	927.6	3359.9
46.6	482.7	909.79	54.0	648.1	1640.5	64.8	933.3	3401.7
46.7	484.7	917.63	54.2	652.9	1664.9	65.0	939.1	3443.9
46.8	486.8	925.51	54.4	657.8	1689.6	65.2	944.9	3486.5
46.9	488.9	933.45	54.6	662.6	1714.6	65.4	950.7	3529.5
47.0	491.0	941.44	54.8	667.5	1739.9	65.6	956.5	3572.9
47.1	493.1	949.47	55.0	672.4	1765.4	65.8	962.3	3616.6
47.2	495.2	957.56	55.2	677.3	1791.2	66.0	968.2	3660.8
47.3	497.3	965.70	55.4	682.2	1817.4	66.2	974.1	3705.4
47.4	499.4	973.90	55.6	687.1	1843.7	66.4	980.0	3750.4
47.5	501.5	982.14	55.8	692.1	1870.4	66.6	985.9	3795.7
47.6	503.6	990.44	56.0	697.0	1897.4	66.8	991.8	3841.5
47.7	505.7	998.79	56.2	702.0	1924.6	67.0	997.8	3887.8
47.8	507.9	1007.2	56.4	707.0	1952.2	67.2	1004	3934.4
47.9	510.0	1015.6	56.6	712.1	1980.0	67.4	1010	3981.4
48.0	512.1	1024.2	56.8	717.1	2008.1	67.6	1016	4028.9
48.1	514.2	1032.7	57.0	722.2	2036.6	67.8	1022	4076.8
48.2	516.4	1041.3	57.2	727.2	2065.3	68.0	1028	4125.1
48.3	518.5	1050.0	57.4	732.3	2094.3	68.2	1034	4173.9
48.4	520.7	1058.7	57.6	737.4	2123.7	68.4	1040	4223.0
48.5	522.8	1067.5	57.8	742.6	2153.3	68.6	1046	4272.6
48.6	525.0	1076.3	58.0	747.7	2183.3	68.8	1052	4322.7
48.7	527.2	1085.2	58.2	752.9	2213.6	69.0	1058	4373.2
48.8	529.3	1094.2	58.4	758.1	2244.1	69.2	1064	4424.1
48.9	531.5	1103.2	58.6	763.3	2275.0	69.4	1071	4475.5
49.0	533.7	1112.2	58.8	768.5	2306.3	69.6	1077	4527.3
49.1	535.9	1121.3	59.0	773.7	2337.8	69.8	1083	4579.5
49.2	538.0	1130.5	59.2	779.0	2369.7	70.0	1089	4632.2
49.3	540.2	1139.7	59.4	784.2	2401.8	70.2	1095	4685.4
49.4	542.4	1149.0	59.6	789.5	2434.4	70.4	1102	4739.0
49.5	544.6	1158.3	59.8	794.8	2467.2	70.6	1108	4793.1

Airflex® Weight and Wk² for Steel Cylinders

Section Z

Diameter (in)	Weight (lb)	Wk ² (lb · ft ²)	Diameter (in)	Weight (lb)	Wk ² (lb · ft ²)	Diameter (in)	Weight (lb)	Wk ² (lb · ft ²)
70.8	1114	4847.7	81.6	1480	8553.8	92.4	1898	14063
71.0	1120	4902.7	81.8	1487	8638.0	92.6	1906	14185
71.2	1127	4958.2	82.0	1495	8722.8	92.8	1914	14308
71.4	1133	5014.1	82.2	1502	8808.2	93.0	1922	14432
71.6	1139	5070.5	82.4	1509	8894.2	93.2	1931	14557
71.8	1146	5127.4	82.6	1516	8980.9	93.4	1939	14682
72.0	1152	5184.8	82.8	1524	9068.2	93.6	1947	14808
72.2	1159	5242.6	83.0	1531	9156.1	93.8	1956	14935
72.4	1165	5301.0	83.2	1539	9244.7	94.0	1964	15063
72.6	1172	5359.8	83.4	1546	9333.9	94.2	1972	15192
72.8	1178	5419.1	83.6	1553	9423.8	94.4	1981	15321
73.0	1184	5478.9	83.8	1561	9514.3	94.6	1989	15451
73.2	1191	5539.2	84.0	1568	9605.4	94.8	1998	15582
73.4	1197	5599.9	84.2	1576	9697.2	95.0	2006	15714
73.6	1204	5661.2	84.4	1583	9789.7	95.2	2014	15847
73.8	1211	5723.0	84.6	1591	9882.8	95.4	2023	15981
74.0	1217	5785.3	84.8	1598	9976.6	95.6	2031	16115
74.2	1224	5848.1	85.0	1606	10071	95.8	2040	16250
74.4	1230	5911.4	85.2	1613	10166	96.0	2048	16386
74.6	1237	5975.2	85.4	1621	10262	96.2	2057	16523
74.8	1244	6039.6	85.6	1629	10358	96.4	2066	16661
75.0	1250	6104.4	85.8	1636	10456	96.6	2074	16800
75.2	1257	6169.8	86.0	1644	10553	96.8	2083	16940
75.4	1264	6235.7	86.2	1652	10652	97.0	2091	17080
75.6	1270	6302.1	86.4	1659	10751	97.2	2100	17221
75.8	1277	6369.1	86.6	1667	10851	97.4	2109	17363
76.0	1284	6436.6	86.8	1675	10952	97.6	2117	17506
76.2	1291	6504.6	87.0	1682	11053	97.8	2126	17650
76.4	1297	6573.1	87.2	1690	11155	98.0	2135	17795
76.6	1304	6642.2	87.4	1698	11258	98.2	2143	17941
76.8	1311	6711.9	87.6	1706	11361	98.4	2152	18088
77.0	1318	6782.1	87.8	1713	11465	98.6	2161	18235
77.2	1325	6852.8	88.0	1721	11570	98.8	2170	18383
77.4	1332	6924.1	88.2	1729	11675	99.0	2178	18533
77.6	1338	6995.9	88.4	1737	11782	99.2	2187	18683
77.8	1345	7068.4	88.6	1745	11889	99.4	2196	18834
78.0	1352	7141.3	88.8	1753	11996	99.6	2205	18986
78.2	1359	7214.8	89.0	1761	12105	99.8	2214	19139
78.4	1366	7288.9	89.2	1769	12214	100.0	2223	19293
78.6	1373	7363.6	89.4	1776	12324	100.2	2232	19448
78.8	1380	7438.8	89.6	1784	12435	100.4	2241	19604
79.0	1387	7514.6	89.8	1792	12546	100.6	2249	19760
79.2	1394	7591.0	90.0	1800	12658	100.8	2258	19918
79.4	1401	7668.0	90.2	1808	12771	101.0	2267	20076
79.6	1408	7745.5	90.4	1816	12885	101.2	2276	20236
79.8	1415	7823.7	90.6	1824	12999	101.4	2285	20396
80.0	1423	7902.4	90.8	1833	13114	101.6	2294	20558
80.2	1430	7981.7	91.0	1841	13230	101.8	2303	20720
80.4	1437	8061.7	91.2	1849	13347	102.0	2312	20883
80.6	1444	8142.2	91.4	1857	13464	102.2	2322	21048
80.8	1451	8223.3	91.6	1865	13583	102.4	2331	21213
81.0	1458	8305.0	91.8	1873	13702	102.6	2340	21379
81.2	1466	8387.3	92.0	1881	13821	102.8	2349	21546
81.4	1473	8470.3	92.2	1889	13942	103.0	2358	21714

Airflex® Weight and Wk^2 for Steel Cylinders

Section Z

Diameter (in)	Weight (lb)	Wk^2 (lb · ft ²)	Diameter (in)	Weight (lb)	Wk^2 (lb · ft ²)
103.2	2367	21884	114.0	2889	32585
103.4	2376	22054	114.2	2899	32814
103.6	2386	22225	114.4	2909	33045
103.8	2395	22397	114.6	2919	33277
104.0	2404	22570	114.8	2929	33509
104.2	2413	22744	115.0	2940	33744
104.4	2423	22919	115.2	2950	33979
104.6	2432	23095	115.4	2960	34216
104.8	2441	23273	115.6	2970	34453
105.0	2451	23451	115.8	2981	34692
105.2	2460	23630	116.0	2991	34933
105.4	2469	23810	116.2	3001	35174
105.6	2479	23991	116.4	3012	35417
105.8	2488	24174	116.6	3022	35661
106.0	2497	24357	116.8	3032	35906
106.2	2507	24541	117.0	3043	36153
106.4	2516	24727	117.2	3053	36401
106.6	2526	24913	117.4	3063	36650
106.8	2535	25101	117.6	3074	36900
107.0	2545	25289	117.8	3084	37152
107.2	2554	25479	118.0	3095	37405
107.4	2564	25669	118.2	3105	37659
107.6	2573	25861	118.4	3116	37915
107.8	2583	26054	118.6	3126	38171
108.0	2593	26248	118.8	3137	38430
108.2	2602	26443	119.0	3148	38689
108.4	2612	26639	119.2	3158	38950
108.6	2621	26836	119.4	3169	39212
108.8	2631	27034	119.6	3179	39475
109.0	2641	27234	119.8	3190	39740
109.2	2650	27434	120.0	3201	40006
109.4	2660	27636			
109.6	2670	27838			
109.8	2680	28042			
110.0	2689	28247			
110.2	2699	28453			
110.4	2709	28660			
110.6	2719	28868			
110.8	2729	29078			
111.0	2739	29288			
111.2	2748	29500			
111.4	2758	29713			
111.6	2768	29927			
111.8	2778	30142			
112.0	2788	30358			
112.2	2798	30575			
112.4	2808	30794			
112.6	2818	31014			
112.8	2828	31235			
113.0	2838	31457			
113.2	2848	31680			
113.4	2858	31905			
113.6	2868	32130			
113.8	2878	32357			

Airflex® Mass and Inertia for Steel Cylinders

Section Z

The table below lists the mass (kg) and inertia J (kg · m²) for various diameter steel cylinders one millimeter long. For other cylinder lengths multiply the table value by the length in millimeters. To obtain values for diameters not listed, use the following formulas:

$$\text{mass (kg/mm)} = 6.1457\text{E-}06 \cdot D^2$$

$$J \text{ (kg.m}^2\text{/mm)} = 7.6875\text{E-}13 \cdot D^4$$

An example illustrating the use of this table appears in front of the Weight and Wk² tables.

Material	Factor
Aluminum	0.346
Bronze	1.120
Cast Iron	0.926
Copper	1.113
Lead	1.449

Diameter (mm)	Mass (kg)	Inertia (kg · m ²)	Diameter (mm)	Mass (kg)	Inertia (kg · m ²)
30	0,006	6E-07	136	0,114	0,0003
32	0,006	8E-07	138	0,117	0,0003
34	0,007	1E-06	140	0,120	0,0003
36	0,008	1E-06	142	0,124	0,0003
38	0,009	2E-06	144	0,127	0,0003
40	0,010	2E-06	146	0,131	0,0003
42	0,011	2E-06	148	0,135	0,0004
44	0,012	3E-06	150	0,138	0,0004
46	0,013	3E-06	152	0,142	0,0004
48	0,014	4E-06	154	0,146	0,0004
50	0,015	5E-06	156	0,150	0,0005
52	0,017	6E-06	158	0,153	0,0005
54	0,018	7E-06	160	0,157	0,0005
56	0,019	8E-06	162	0,161	0,0005
58	0,021	9E-06	164	0,165	0,0006
60	0,022	1E-05	166	0,169	0,0006
62	0,024	1E-05	168	0,173	0,0006
64	0,025	1E-05	170	0,178	0,0006
66	0,027	1E-05	172	0,182	0,0007
68	0,028	2E-05	174	0,186	0,0007
70	0,030	2E-05	176	0,190	0,0007
72	0,032	2E-05	178	0,195	0,0008
74	0,034	2E-05	180	0,199	0,0008
76	0,035	3E-05	182	0,204	0,0008
78	0,037	3E-05	184	0,208	0,0009
80	0,039	3E-05	186	0,213	0,0009
82	0,041	3E-05	188	0,217	0,0010
84	0,043	4E-05	190	0,222	0,0010
86	0,045	4E-05	192	0,227	0,0010
88	0,048	5E-05	194	0,231	0,0011
90	0,050	5E-05	196	0,236	0,0011
92	0,052	6E-05	198	0,241	0,0012
94	0,054	6E-05	200	0,246	0,0012
96	0,057	7E-05	202	0,251	0,0013
98	0,059	7E-05	204	0,256	0,0013
100	0,061	8E-05	206	0,261	0,0014
102	0,064	8E-05	208	0,266	0,0014
104	0,066	9E-05	210	0,271	0,0015
106	0,069	1E-04	212	0,276	0,0016
108	0,072	0,0001	214	0,281	0,0016
110	0,074	0,0001	216	0,287	0,0017
112	0,077	0,0001	218	0,292	0,0017
114	0,080	0,0001	220	0,297	0,0018
116	0,083	0,0001	222	0,303	0,0019
118	0,086	0,0001	224	0,308	0,0019
120	0,088	0,0002	226	0,314	0,0020
122	0,091	0,0002	228	0,319	0,0021
124	0,094	0,0002	230	0,325	0,0022
126	0,098	0,0002	232	0,331	0,0022
128	0,101	0,0002	234	0,337	0,0023
130	0,104	0,0002	236	0,342	0,0024
132	0,107	0,0002	238	0,348	0,0025
134	0,110	0,0002	240	0,354	0,0026

Airflex® Mass and Inertia for Steel Cylinders

Section Z

Diameter (mm)	Mass (kg)	Inertia (kg · m ²)	Diameter (mm)	Mass (kg)	Inertia (kg · m ²)	Diameter (mm)	Mass (kg)	Inertia (kg · m ²)
242	0,360	0,0026	348	0,744	0,0113	454	1,267	0,0327
244	0,366	0,0027	350	0,753	0,0115	456	1,278	0,0332
246	0,372	0,0028	352	0,761	0,0118	458	1,289	0,0338
248	0,378	0,0029	354	0,770	0,0121	460	1,300	0,0344
250	0,384	0,0030	356	0,779	0,0123	462	1,312	0,0350
252	0,390	0,0031	358	0,788	0,0126	464	1,323	0,0356
254	0,396	0,0032	360	0,796	0,0129	466	1,335	0,0363
256	0,403	0,0033	362	0,805	0,0132	468	1,346	0,0369
258	0,409	0,0034	364	0,814	0,0135	470	1,358	0,0375
260	0,415	0,0035	366	0,823	0,0138	472	1,369	0,0382
262	0,422	0,0036	368	0,832	0,0141	474	1,381	0,0388
264	0,428	0,0037	370	0,841	0,0144	476	1,392	0,0395
266	0,435	0,0038	372	0,850	0,0147	478	1,404	0,0401
268	0,441	0,0040	374	0,860	0,0150	480	1,416	0,0408
270	0,448	0,0041	376	0,869	0,0154	482	1,428	0,0415
272	0,455	0,0042	378	0,878	0,0157	484	1,440	0,0422
274	0,461	0,0043	380	0,887	0,0160	486	1,452	0,0429
276	0,468	0,0045	382	0,897	0,0164	488	1,464	0,0436
278	0,475	0,0046	384	0,906	0,0167	490	1,476	0,0443
280	0,482	0,0047	386	0,916	0,0171	492	1,488	0,0450
282	0,489	0,0049	388	0,925	0,0174	494	1,500	0,0458
284	0,496	0,0050	390	0,935	0,0178	496	1,512	0,0465
286	0,503	0,0051	392	0,944	0,0182	498	1,524	0,0473
288	0,510	0,0053	394	0,954	0,0185	500	1,536	0,0480
290	0,517	0,0054	396	0,964	0,0189	502	1,549	0,0488
292	0,524	0,0056	398	0,974	0,0193	504	1,561	0,0496
294	0,531	0,0057	400	0,983	0,0197	506	1,574	0,0504
296	0,538	0,0059	402	0,993	0,0201	508	1,586	0,0512
298	0,546	0,0061	404	1,003	0,0205	510	1,598	0,0520
300	0,553	0,0062	406	1,013	0,0209	512	1,611	0,0528
302	0,561	0,0064	408	1,023	0,0213	514	1,624	0,0537
304	0,568	0,0066	410	1,033	0,0217	516	1,636	0,0545
306	0,575	0,0067	412	1,043	0,0222	518	1,649	0,0553
308	0,583	0,0069	414	1,053	0,0226	520	1,662	0,0562
310	0,591	0,0071	416	1,064	0,0230	522	1,675	0,0571
312	0,598	0,0073	418	1,074	0,0235	524	1,687	0,0580
314	0,606	0,0075	420	1,084	0,0239	526	1,700	0,0588
316	0,614	0,0077	422	1,094	0,0244	528	1,713	0,0597
318	0,621	0,0079	424	1,105	0,0248	530	1,726	0,0607
320	0,629	0,0081	426	1,115	0,0253	532	1,739	0,0616
322	0,637	0,0083	428	1,126	0,0258	534	1,752	0,0625
324	0,645	0,0085	430	1,136	0,0263	536	1,766	0,0635
326	0,653	0,0087	432	1,147	0,0268	538	1,779	0,0644
328	0,661	0,0089	434	1,158	0,0273	540	1,792	0,0654
330	0,669	0,0091	436	1,168	0,0278	542	1,805	0,0663
332	0,677	0,0093	438	1,179	0,0283	544	1,819	0,0673
334	0,686	0,0096	440	1,190	0,0288	546	1,832	0,0683
336	0,694	0,0098	442	1,201	0,0293	548	1,846	0,0693
338	0,702	0,0100	444	1,212	0,0299	550	1,859	0,0703
340	0,710	0,0103	446	1,222	0,0304	552	1,873	0,0714
342	0,719	0,0105	448	1,233	0,0310	554	1,886	0,0724
344	0,727	0,0108	450	1,245	0,0315	556	1,900	0,0735
346	0,736	0,0110	452	1,256	0,0321	558	1,914	0,0745

Airflex® Mass and Inertia for Steel Cylinders

Section Z

Diameter (mm)	Mass (kg)	Inertia (kg · m ²)	Diameter (mm)	Mass (kg)	Inertia (kg · m ²)	Diameter (mm)	Mass (kg)	Inertia (kg · m ²)
560	1,927	0,0756	666	2,726	0,1512	772	3,663	0,2731
562	1,941	0,0767	668	2,742	0,1531	774	3,682	0,2759
564	1,955	0,0778	670	2,759	0,1549	776	3,701	0,2788
566	1,969	0,0789	672	2,775	0,1568	778	3,720	0,2816
568	1,983	0,0800	674	2,792	0,1586	780	3,739	0,2846
570	1,997	0,0811	676	2,808	0,1605	782	3,758	0,2875
572	2,011	0,0823	678	2,825	0,1624	784	3,777	0,2904
574	2,025	0,0835	680	2,842	0,1644	786	3,797	0,2934
576	2,039	0,0846	682	2,859	0,1663	788	3,816	0,2964
578	2,053	0,0858	684	2,875	0,1683	790	3,836	0,2994
580	2,067	0,0870	686	2,892	0,1702	792	3,855	0,3025
582	2,082	0,0882	688	2,909	0,1722	794	3,874	0,3055
584	2,096	0,0894	690	2,926	0,1743	796	3,894	0,3086
586	2,110	0,0907	692	2,943	0,1763	798	3,914	0,3117
588	2,125	0,0919	694	2,960	0,1783	800	3,933	0,3149
590	2,139	0,0932	696	2,977	0,1804	802	3,953	0,3180
592	2,154	0,0944	698	2,994	0,1825	804	3,973	0,3212
594	2,168	0,0957	700	3,011	0,1846	806	3,992	0,3244
596	2,183	0,0970	702	3,029	0,1867	808	4,012	0,3277
598	2,198	0,0983	704	3,046	0,1888	810	4,032	0,3309
600	2,212	0,0996	706	3,063	0,1910	812	4,052	0,3342
602	2,227	0,1010	708	3,081	0,1932	814	4,072	0,3375
604	2,242	0,1023	710	3,098	0,1954	816	4,092	0,3408
606	2,257	0,1037	712	3,116	0,1976	818	4,112	0,3442
608	2,272	0,1051	714	3,133	0,1998	820	4,132	0,3476
610	2,287	0,1064	716	3,151	0,2020	822	4,153	0,3510
612	2,302	0,1078	718	3,168	0,2043	824	4,173	0,3544
614	2,317	0,1093	720	3,186	0,2066	826	4,193	0,3579
616	2,332	0,1107	722	3,204	0,2089	828	4,213	0,3613
618	2,347	0,1121	724	3,221	0,2112	830	4,234	0,3648
620	2,362	0,1136	726	3,239	0,2136	832	4,254	0,3684
622	2,378	0,1151	728	3,257	0,2159	834	4,275	0,3719
624	2,393	0,1166	730	3,275	0,2183	836	4,295	0,3755
626	2,408	0,1181	732	3,293	0,2207	838	4,316	0,3791
628	2,424	0,1196	734	3,311	0,2231	840	4,336	0,3827
630	2,439	0,1211	736	3,329	0,2256	842	4,357	0,3864
632	2,455	0,1226	738	3,347	0,2280	844	4,378	0,3901
634	2,470	0,1242	740	3,365	0,2305	846	4,399	0,3938
636	2,486	0,1258	742	3,384	0,2330	848	4,419	0,3975
638	2,502	0,1274	744	3,402	0,2355	850	4,440	0,4013
640	2,517	0,1290	746	3,420	0,2381	852	4,461	0,4051
642	2,533	0,1306	748	3,439	0,2407	854	4,482	0,4089
644	2,549	0,1322	750	3,457	0,2432	856	4,503	0,4127
646	2,565	0,1339	752	3,475	0,2458	858	4,524	0,4166
648	2,581	0,1355	754	3,494	0,2485	860	4,545	0,4205
650	2,597	0,1372	756	3,512	0,2511	862	4,567	0,4244
652	2,613	0,1389	758	3,531	0,2538	864	4,588	0,4284
654	2,629	0,1406	760	3,550	0,2565	866	4,609	0,4324
656	2,645	0,1424	762	3,568	0,2592	868	4,630	0,4364
658	2,661	0,1441	764	3,587	0,2619	870	4,652	0,4404
660	2,677	0,1459	766	3,606	0,2647	872	4,673	0,4445
662	2,693	0,1476	768	3,625	0,2674	874	4,695	0,4486
664	2,710	0,1494	770	3,644	0,2702	876	4,716	0,4527

Airflex® Mass and Inertia for Steel Cylinders

Section Z

Diameter (mm)	Mass (kg)	Inertia (kgxm ²)	Diameter (mm)	Mass (kg)	Inertia (kgxm ²)	Diameter (mm)	Mass (kg)	Inertia (kgxm ²)
878	4,738	0,4568	984	5,951	0,7207	1090	7,302	1,0852
880	4,759	0,4610	986	5,975	0,7266	1092	7,329	1,0931
882	4,781	0,4652	988	5,999	0,7325	1094	7,355	1,1012
884	4,803	0,4695	990	6,023	0,7385	1096	7,382	1,1092
886	4,824	0,4737	992	6,048	0,7444	1098	7,409	1,1174
888	4,846	0,4780	994	6,072	0,7505	1100	7,436	1,1255
890	4,868	0,4823	996	6,097	0,7565	1102	7,463	1,1337
892	4,890	0,4867	998	6,121	0,7626	1104	7,490	1,1420
894	4,912	0,4911	1000	6,146	0,7688	1106	7,518	1,1503
896	4,934	0,4955	1002	6,170	0,7749	1108	7,545	1,1586
898	4,956	0,4999	1004	6,195	0,7811	1110	7,572	1,1670
900	4,978	0,5044	1006	6,220	0,7874	1112	7,599	1,1755
902	5,000	0,5089	1008	6,244	0,7936	1114	7,627	1,1839
904	5,022	0,5134	1010	6,269	0,8000	1116	7,654	1,1925
906	5,045	0,5180	1012	6,294	0,8063	1118	7,682	1,2010
908	5,067	0,5226	1014	6,319	0,8127	1120	7,709	1,2096
910	5,089	0,5272	1016	6,344	0,8191	1122	7,737	1,2183
912	5,112	0,5318	1018	6,369	0,8256	1124	7,764	1,2270
914	5,134	0,5365	1020	6,394	0,8321	1126	7,792	1,2358
916	5,157	0,5412	1022	6,419	0,8387	1128	7,820	1,2446
918	5,179	0,5460	1024	6,444	0,8452	1130	7,847	1,2534
920	5,202	0,5507	1026	6,469	0,8519	1132	7,875	1,2623
922	5,224	0,5555	1028	6,495	0,8585	1134	7,903	1,2713
924	5,247	0,5604	1030	6,520	0,8652	1136	7,931	1,2803
926	5,270	0,5652	1032	6,545	0,8720	1138	7,959	1,2893
928	5,293	0,5701	1034	6,571	0,8788	1140	7,987	1,2984
930	5,315	0,5751	1036	6,596	0,8856	1142	8,015	1,3075
932	5,338	0,5800	1038	6,622	0,8924	1144	8,043	1,3167
934	5,361	0,5850	1040	6,647	0,8993	1146	8,071	1,3259
936	5,384	0,5900	1042	6,673	0,9063	1148	8,099	1,3352
938	5,407	0,5951	1044	6,698	0,9132	1150	8,128	1,3445
940	5,430	0,6002	1046	6,724	0,9203	1152	8,156	1,3539
942	5,453	0,6053	1048	6,750	0,9273	1154	8,184	1,3634
944	5,477	0,6105	1050	6,776	0,9344	1156	8,213	1,3728
946	5,500	0,6157	1052	6,801	0,9416	1158	8,241	1,3824
948	5,523	0,6209	1054	6,827	0,9487	1160	8,270	1,3919
950	5,546	0,6262	1056	6,853	0,9560	1162	8,298	1,4016
952	5,570	0,6314	1058	6,879	0,9632	1164	8,327	1,4112
954	5,593	0,6368	1060	6,905	0,9705	1166	8,355	1,4210
956	5,617	0,6421	1062	6,931	0,9779	1168	8,384	1,4307
958	5,640	0,6475	1064	6,958	0,9853	1170	8,413	1,4406
960	5,664	0,6529	1066	6,984	0,9927	1172	8,442	1,4504
962	5,688	0,6584	1068	7,010	1,0002	1174	8,470	1,4604
964	5,711	0,6639	1070	7,036	1,0077	1176	8,499	1,4703
966	5,735	0,6694	1072	7,063	1,0152	1178	8,528	1,4804
968	5,759	0,6750	1074	7,089	1,0228	1180	8,557	1,4904
970	5,782	0,6806	1076	7,115	1,0305	1182	8,586	1,5006
972	5,806	0,6862	1078	7,142	1,0382	1184	8,615	1,5107
974	5,830	0,6919	1080	7,168	1,0459	1186	8,645	1,5210
976	5,854	0,6976	1082	7,195	1,0536	1188	8,674	1,5313
978	5,878	0,7033	1084	7,222	1,0615	1190	8,703	1,5416
980	5,902	0,7091	1086	7,248	1,0693	1192	8,732	1,5520
982	5,926	0,7149	1088	7,275	1,0772	1194	8,762	1,5624

Airflex® Mass and Inertia for Steel Cylinders

Section Z

Diameter (mm)	Mass (kg)	Inertia (kg · m ²)	Diameter (mm)	Mass (kg)	Inertia (kg · m ²)	Diameter (mm)	Mass (kg)	Inertia (kg · m ²)
1196	8,791	1,5729	1305	10,47	2,2296	1570	15,15	4,6707
1198	8,820	1,5835	1310	10,55	2,2640	1575	15,25	4,7305
1200	8,850	1,5941	1315	10,63	2,2987	1580	15,34	4,7909
1202	8,879	1,6047	1320	10,71	2,3339	1585	15,44	4,8518
1204	8,909	1,6154	1325	10,79	2,3695	1590	15,54	4,9133
1206	8,939	1,6262	1330	10,87	2,4054	1595	15,63	4,9754
1208	8,968	1,6370	1335	10,95	2,4418	1600	15,73	5,0381
1210	8,998	1,6479	1340	11,04	2,4786	1605	15,83	5,1014
1212	9,028	1,6588	1345	11,12	2,5158	1610	15,93	5,1652
1214	9,058	1,6698	1350	11,20	2,5534	1615	16,03	5,2297
1216	9,087	1,6808	1355	11,28	2,5914	1620	16,13	5,2947
1218	9,117	1,6919	1360	11,37	2,6299	1625	16,23	5,3604
1220	9,147	1,7030	1365	11,45	2,6688	1630	16,33	5,4267
1222	9,177	1,7142	1370	11,53	2,7081	1635	16,43	5,4936
1224	9,207	1,7255	1375	11,62	2,7479	1640	16,53	5,5611
1226	9,237	1,7368	1380	11,70	2,7881	1645	16,63	5,6292
1228	9,268	1,7481	1385	11,79	2,8287	1650	16,73	5,6980
1230	9,298	1,7596	1390	11,87	2,8698	1655	16,83	5,7674
1232	9,328	1,7710	1395	11,96	2,9113	1660	16,94	5,8374
1234	9,358	1,7826	1400	12,05	2,9532	1665	17,04	5,9080
1236	9,389	1,7942	1405	12,13	2,9956	1670	17,14	5,9793
1238	9,419	1,8058	1410	12,22	3,0385	1675	17,24	6,0512
1240	9,450	1,8175	1415	12,31	3,0818	1680	17,35	6,1238
1242	9,480	1,8292	1420	12,39	3,1256	1685	17,45	6,1970
1244	9,511	1,8411	1425	12,48	3,1699	1690	17,55	6,2709
1246	9,541	1,8529	1430	12,57	3,2146	1695	17,66	6,3455
1248	9,572	1,8648	1435	12,66	3,2598	1700	17,76	6,4207
1250	9,603	1,8768	1440	12,74	3,3055	1705	17,87	6,4965
1252	9,633	1,8889	1445	12,83	3,3516	1710	17,97	6,5731
1254	9,664	1,9010	1450	12,92	3,3983	1715	18,08	6,6503
1256	9,695	1,9131	1455	13,01	3,4454	1720	18,18	6,7282
1258	9,726	1,9253	1460	13,10	3,4930	1725	18,29	6,8068
1260	9,757	1,9376	1465	13,19	3,5411	1730	18,39	6,8860
1262	9,788	1,9499	1470	13,28	3,5897	1735	18,50	6,9660
1264	9,819	1,9623	1475	13,37	3,6388	1740	18,61	7,0466
1266	9,850	1,9748	1480	13,46	3,6883	1745	18,71	7,1280
1268	9,881	1,9873	1485	13,55	3,7384	1750	18,82	7,2100
1270	9,912	1,9999	1490	13,64	3,7890	1755	18,93	7,2928
1272	9,944	2,0125	1495	13,74	3,8402	1760	19,04	7,3763
1274	9,975	2,0252	1500	13,83	3,8918	1765	19,15	7,4604
1276	10,01	2,0379	1505	13,92	3,9439	1770	19,25	7,5453
1278	10,04	2,0507	1510	14,01	3,9966	1775	19,36	7,6309
1280	10,07	2,0636	1515	14,11	4,0498	1780	19,47	7,7173
1282	10,10	2,0765	1520	14,20	4,1035	1785	19,58	7,8044
1284	10,13	2,0895	1525	14,29	4,1578	1790	19,69	7,8922
1286	10,16	2,1026	1530	14,39	4,2126	1795	19,80	7,9807
1288	10,20	2,1157	1535	14,48	4,2679	1800	19,91	8,0700
1290	10,23	2,1288	1540	14,58	4,3238	1805	20,02	8,1601
1292	10,26	2,1421	1545	14,67	4,3803	1810	20,13	8,2509
1294	10,29	2,1554	1550	14,77	4,4372	1815	20,25	8,3424
1296	10,32	2,1687	1555	14,86	4,4948	1820	20,36	8,4347
1298	10,35	2,1821	1560	14,96	4,5529	1825	20,47	8,5278
1300	10,39	2,1956	1565	15,05	4,6115	1830	20,58	8,6216

Airflex® Mass and Inertia for Steel Cylinders

Section Z

Diameter (mm)	Mass (kg)	Inertia (kg · m ²)	Diameter (mm)	Mass (kg)	Inertia (kg · m ²)	Diameter (mm)	Mass (kg)	Inertia (kg · m ²)
1835	20,69	8,7162	2100	27,10	14,951	2365	34,37	24,050
1840	20,81	8,8116	2105	27,23	15,094	2370	34,52	24,254
1845	20,92	8,9078	2110	27,36	15,238	2375	34,67	24,459
1850	21,03	9,0048	2115	27,49	15,382	2380	34,81	24,666
1855	21,15	9,1025	2120	27,62	15,528	2385	34,96	24,874
1860	21,26	9,2010	2125	27,75	15,675	2390	35,10	25,083
1865	21,38	9,3004	2130	27,88	15,824	2395	35,25	25,293
1870	21,49	9,4005	2135	28,01	15,973	2400	35,40	25,505
1875	21,61	9,5015	2140	28,14	16,123	2405	35,55	25,718
1880	21,72	9,6032	2145	28,28	16,274	2410	35,69	25,933
1885	21,84	9,7058	2150	28,41	16,426	2415	35,84	26,149
1890	21,95	9,8092	2155	28,54	16,580	2420	35,99	26,366
1895	22,07	9,9134	2160	28,67	16,734	2425	36,14	26,585
1900	22,19	10,018	2165	28,81	16,889	2430	36,29	26,805
1905	22,30	10,124	2170	28,94	17,046	2435	36,44	27,026
1910	22,42	10,231	2175	29,07	17,204	2440	36,59	27,249
1915	22,54	10,339	2180	29,21	17,362	2445	36,74	27,473
1920	22,66	10,447	2185	29,34	17,522	2450	36,89	27,698
1925	22,77	10,556	2190	29,48	17,683	2455	37,04	27,925
1930	22,89	10,666	2195	29,61	17,845	2460	37,19	28,153
1935	23,01	10,777	2200	29,75	18,008	2465	37,34	28,383
1940	23,13	10,889	2205	29,88	18,173	2470	37,49	28,614
1945	23,25	11,002	2210	30,02	18,338	2475	37,65	28,846
1950	23,37	11,115	2215	30,15	18,505	2480	37,80	29,080
1955	23,49	11,230	2220	30,29	18,672	2485	37,95	29,315
1960	23,61	11,345	2225	30,43	18,841	2490	38,10	29,552
1965	23,73	11,461	2230	30,56	19,011	2495	38,26	29,790
1970	23,85	11,578	2235	30,70	19,182	2500	38,41	30,029
1975	23,97	11,696	2240	30,84	19,354	2505	38,56	30,270
1980	24,09	11,815	2245	30,97	19,528	2510	38,72	30,513
1985	24,22	11,935	2250	31,11	19,702	2515	38,87	30,757
1990	24,34	12,056	2255	31,25	19,878	2520	39,03	31,002
1995	24,46	12,177	2260	31,39	20,055	2525	39,18	31,249
2000	24,58	12,300	2265	31,53	20,233	2530	39,34	31,497
2005	24,71	12,423	2270	31,67	20,412	2535	39,49	31,747
2010	24,83	12,548	2275	31,81	20,593	2540	39,65	31,998
2015	24,95	12,673	2280	31,95	20,774	2545	39,81	32,250
2020	25,08	12,799	2285	32,09	20,957	2550	39,96	32,505
2025	25,20	12,927	2290	32,23	21,141	2555	40,12	32,760
2030	25,33	13,055	2295	32,37	21,326	2560	40,28	33,018
2035	25,45	13,184	2300	32,51	21,513	2565	40,43	33,276
2040	25,58	13,314	2305	32,65	21,700	2570	40,59	33,536
2045	25,70	13,445	2310	32,79	21,889	2575	40,75	33,798
2050	25,83	13,577	2315	32,94	22,079	2580	40,91	34,062
2055	25,95	13,710	2320	33,08	22,271	2585	41,07	34,326
2060	26,08	13,844	2325	33,22	22,463	2590	41,23	34,593
2065	26,21	13,979	2330	33,36	22,657	2595	41,39	34,861
2070	26,33	14,115	2335	33,51	22,852	2600	41,54	35,130
2075	26,46	14,251	2340	33,65	23,049	2605	41,70	35,401
2080	26,59	14,389	2345	33,80	23,246	2610	41,87	35,674
2085	26,72	14,528	2350	33,94	23,445	2615	42,03	35,948
2090	26,85	14,668	2355	34,08	23,646	2620	42,19	36,223
2095	26,97	14,809	2360	34,23	23,847	2625	42,35	36,501

Airflex® Mass and Inertia for Steel Cylinders

Section Z

Diameter (mm)	Mass (kg)	Inertia (kg · m ²)	Diameter (mm)	Mass (kg)	Inertia (kg · m ²)
2630	42,51	36,780	2895	51,51	53,998
2635	42,67	37,060	2900	51,69	54,372
2640	42,83	37,342	2905	51,86	54,748
2645	43,00	37,626	2910	52,04	55,126
2650	43,16	37,911	2915	52,22	55,506
2655	43,32	38,198	2920	52,40	55,888
2660	43,48	38,487	2925	52,58	56,272
2665	43,65	38,777	2930	52,76	56,657
2670	43,81	39,069	2935	52,94	57,045
2675	43,98	39,362	2940	53,12	57,435
2680	44,14	39,657	2945	53,30	57,826
2685	44,31	39,954	2950	53,48	58,220
2690	44,47	40,253	2955	53,66	58,616
2695	44,64	40,553	2960	53,85	59,014
2700	44,80	40,855	2965	54,03	59,413
2705	44,97	41,158	2970	54,21	59,815
2710	45,13	41,463	2975	54,39	60,219
2715	45,30	41,770	2980	54,58	60,625
2720	45,47	42,079	2985	54,76	61,033
2725	45,64	42,389	2990	54,94	61,443
2730	45,80	42,701	2995	55,13	61,855
2735	45,97	43,014	3000	55,31	62,269
2740	46,14	43,330			
2745	46,31	43,647			
2750	46,48	43,966			
2755	46,65	44,287			
2760	46,82	44,609			
2765	46,99	44,933			
2770	47,16	45,259			
2775	47,33	45,587			
2780	47,50	45,916			
2785	47,67	46,247			
2790	47,84	46,580			
2795	48,01	46,915			
2800	48,18	47,252			
2805	48,35	47,590			
2810	48,53	47,930			
2815	48,70	48,272			
2820	48,87	48,616			
2825	49,05	48,962			
2830	49,22	49,310			
2835	49,39	49,659			
2840	49,57	50,010			
2845	49,74	50,363			
2850	49,92	50,718			
2855	50,09	51,075			
2860	50,27	51,434			
2865	50,45	51,794			
2870	50,62	52,157			
2875	50,80	52,521			
2880	50,97	52,888			
2885	51,15	53,256			
2890	51,33	53,626			

Airflex® Formulas for Geometric

Solids Radius of Gyration

Section Z

The formulas on the following pages permit weight and Wk^2 or mass and inertia calculations of complex parts by dividing them into common geometric components.

Subscript _{gg} indicates an axis which passed through the center of gravity of the geometric solid. Subscript _{xx} indicates any other parallel axis of rotation.

The sum of the component's weight or mass results in the total weight or mass of the complex part.

The product of the weight and radius of gyration squared results in the Wk^2 of the component. The sum of all the component Wk^2 's referred to the axis of rotation results in the Wk^2 of the complex part.

The product of the mass and radius of gyration squared results in the moment of inertia of component.

EXAMPLE:

Using the geometrical solid formulas determine the mass and moment of inertia for the part shown below.

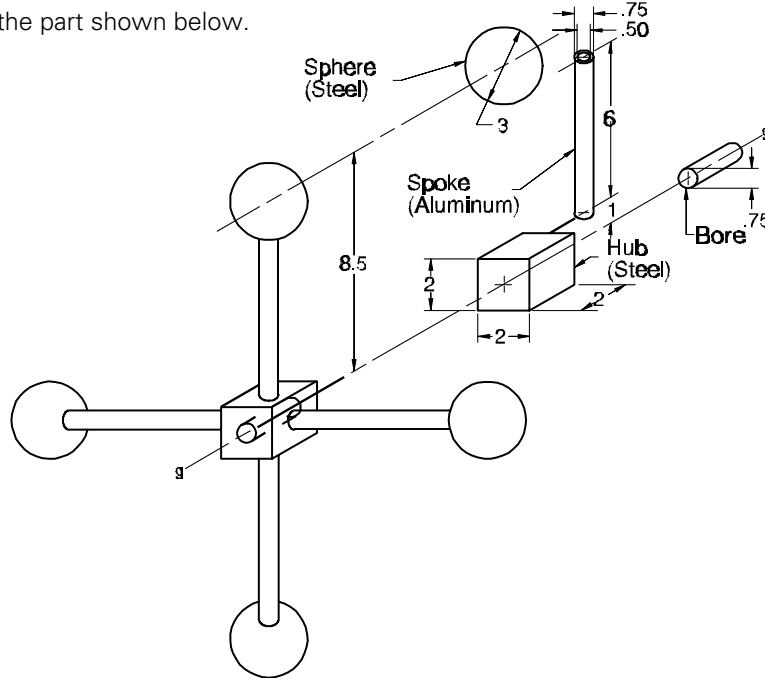

MATERIAL	ρ (lb / in ³)	ρ (kg / m ³)
Aluminum	0.098	2710
Bronze	0.317	8765
Cast Iron	0.262	7244
Copper	0.315	8710
Lead	0.410	11337
Steel	0.283	7825

Component	Weight Calculation	Weight (lb)
Hub	$\rho \cdot H \cdot T \cdot L = .283 \cdot 2 \cdot 2 \cdot 2$	= 2.3
Bore	$-\frac{\rho \cdot \pi \cdot D^2 \cdot L}{4} = -\frac{.283 \cdot \pi \cdot .75^2 \cdot 2}{4}$	= -.3
Spoke	$4 \cdot \left[\frac{\pi}{4} \cdot \rho \cdot L \cdot (D^2 - d^2) \right] = \pi \cdot .098 \cdot 6 \cdot (.75^2 - .5^2)$	= .6
Spheres	$4 \cdot \left[\frac{\pi \cdot \rho \cdot D^3}{6} \right] = \frac{4 \cdot \pi \cdot .283 \cdot 3^3}{6}$	= 16.0
Total weight		= 18.6 lb
Mass = .58 slug		(8.4 kg)

Component	Radius of Gyration Calculation	k^2 (in ²)
Hub	$\frac{H^2 + L^2}{12} = \frac{2^2 + 2^2}{12}$	= .67
Bore	$\frac{D^2}{8} = \frac{.75^2}{8}$	= .07
Spoke	$\frac{D^2 + d^2}{16} + \frac{L^2}{12} + r^2 = \frac{.75^2 + .5^2}{16} + \frac{6^2}{12} + (3+1)^2$	= 19.05
Sphere	$\frac{D^2}{10} + y^2 = \frac{3^2}{10} + 8.5^2$	= 73.15

Component	Wk^2 Calculations	Wk^2 (lb·in ²)
Hub	$2.3 \cdot .67$	= 1.54
Bore	$-.3 \cdot .07$	= -.02
Spoke	$.6 \cdot 19.05$	= 11.43
Sphere	$16.0 \cdot 73.15$	= 1170.40
Wk^2		= 1183 lb · in ²
$J = \frac{Wk^2}{g} = \frac{8.22}{32.2} = .26 \text{ lb} \cdot \text{ft} \cdot \text{sec}^2$ (.35 kg · m ²)		= 8.22 lb · ft ²

Airflex® Formulas for Geometric Solids

Radius of Gyration

Section Z

Rectangular Prism

$$\text{Weight} = \rho H T L$$

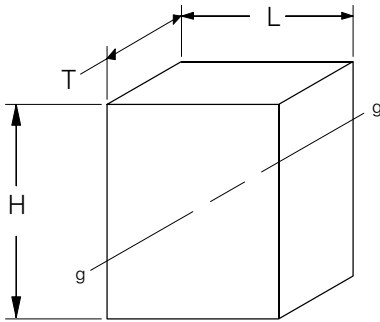

$$k_{gg}^2 = \frac{H^2 + L^2}{12}$$

Solid Cylinders

$$\text{Weight} = \frac{\rho \pi D^2 L}{4}$$

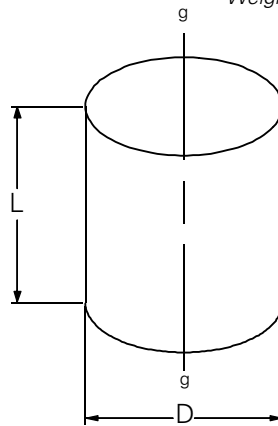

$$k_{gg}^2 = \frac{D^2}{8}$$

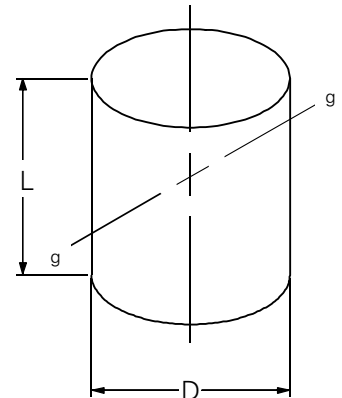

$$k_{gg}^2 = \frac{L^2}{12} + \frac{D^2}{16}$$

Ellipsoidal Cylinders

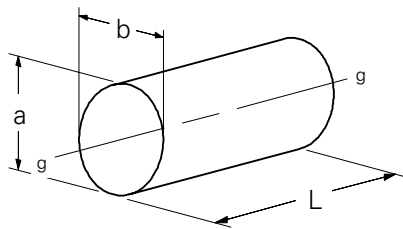

$$k_{gg}^2 = \frac{a^2 + b^2}{16}$$

Hollow Cylinders

$$\text{Weight} = \frac{\pi}{4} \rho L (D^2 - d^2)$$

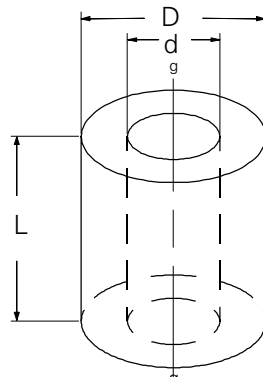

$$k_{gg}^2 = \frac{D^2 + d^2}{8}$$

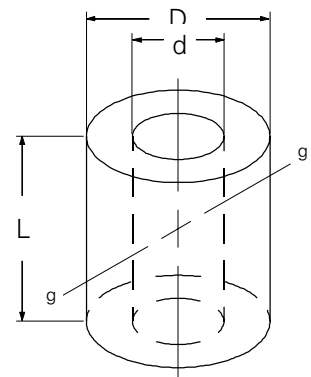

$$k_{gg}^2 = \frac{D^2 + d^2}{16} + \frac{L^2}{12}$$

Cones

$$\text{Weight} = \frac{\rho \pi D^2 L}{12}$$

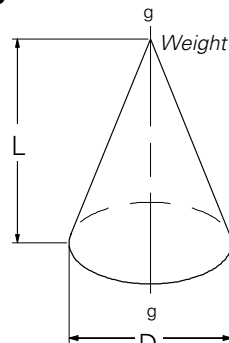

$$k_{gg}^2 = \frac{3D^2}{40}$$

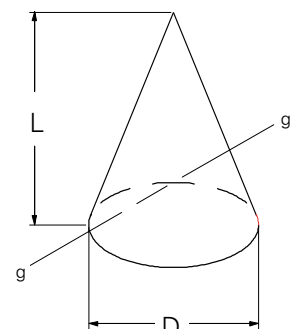

$$k_{gg}^2 = \frac{3D^2 + 3L^2}{80}$$

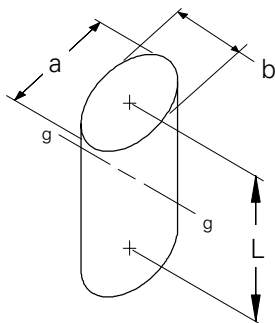

$$k_{gg}^2 = \frac{\pi a^2}{64} + \frac{L^2}{12}$$

Airflex® Formulas for Geometric Solids

Radius of Gyration

Section Z

Frustrums of Cones

$$\text{Weight} = \frac{\rho \pi L}{12} \frac{(D^3 - d^3)}{(D - d)}$$

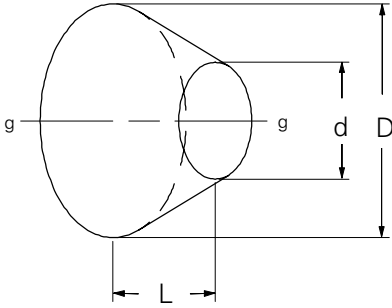

$$k_{gg}^2 = \frac{3(D^5 - d^5)}{40(D^3 - d^3)}$$

$$\text{Weight} = \frac{\rho \pi L}{4} \left[\frac{(D^3 - d^3)}{3(D - d)} - d^2 \right]$$

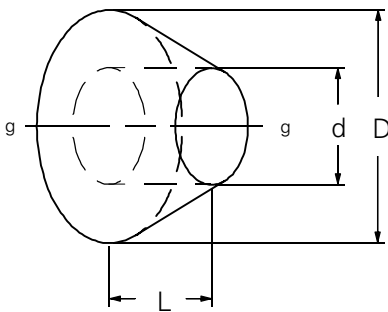

$$k_{gg}^2 = \frac{3}{40} \left[\frac{D^5 - 5Dd^4 + 4d^5}{D^3 - 3Dd^2 + 2d^3} \right]$$

$$\text{Weight} = \frac{\rho \pi L}{4} \left[D^2 - \frac{(D^3 - d^3)}{3(D - d)} \right]$$

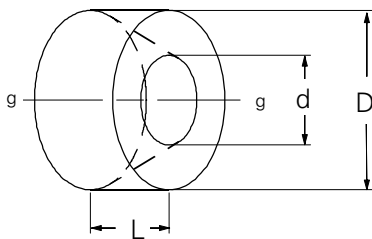

$$k_{gg}^2 = \frac{3}{40} \left[\frac{4D^5 - 5D^4d + d^5}{2D^3 - 3D^2d + d^3} \right]$$

Paraboloid

$$\text{Weight} = \frac{\rho \pi L D^2}{8}$$

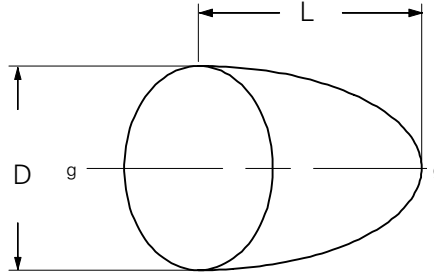

$$k_{gg}^2 = \frac{D^2}{12}$$

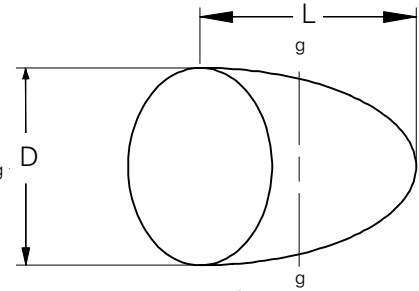

$$k_{gg}^2 = \frac{3D^2 + 4L^2}{72}$$

Elliptic Paraboloids

$$\text{Weight} = \frac{\rho \pi a b L}{8}$$

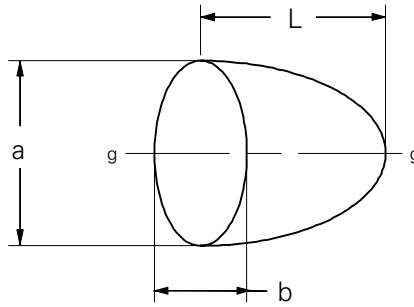

$$k_{gg}^2 = \frac{a^2 + b^2}{24}$$

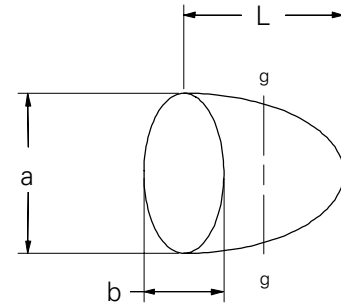

$$k_{gg}^2 = \frac{3b^2 + 4L^2}{72}$$

Rectangular Pyramids

$$\text{Weight} = \frac{a b L}{3} \rho$$

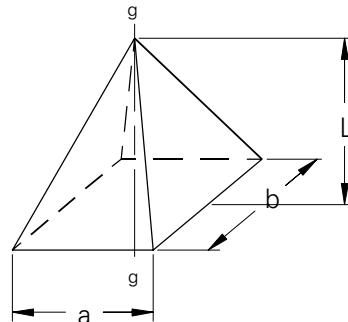

$$k_{gg}^2 = \frac{a^2 + b^2}{20}$$

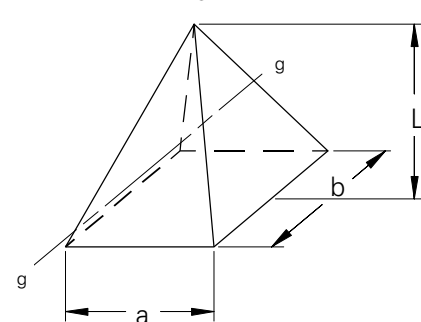

$$k_{gg}^2 = \frac{4a^2 + 3L^2}{80}$$

Airflex® Formulas for Geometric Solids

Radius of Gyration

Section Z

Spheres

$$\text{Weight} = \frac{\rho \pi D^3}{12}$$

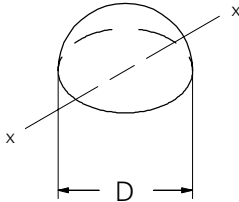

$$k_{xx}^2 = \frac{D^2}{10}$$

$$\text{Weight} = \frac{\rho \pi D^3}{6}$$

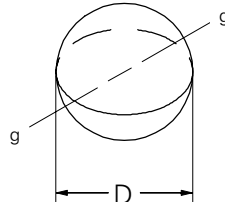

$$k_{gg}^2 = \frac{D^2}{10}$$

$$\text{Weight} = \frac{\rho \pi}{6} (D^3 - d^3)$$

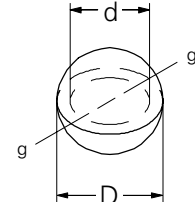

$$k_{gg}^2 = \frac{D^5 - d^5}{10(D^3 - d^3)}$$

Ellipsoids

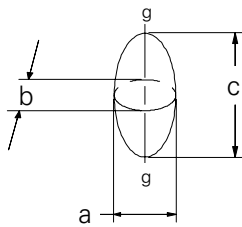

$$k_{gg}^2 = \frac{a^2 + b^2}{20}$$

$$\text{Weight} = \frac{\rho \pi a b c}{6}$$

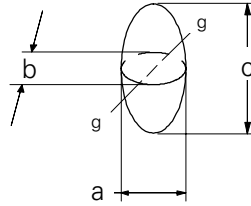

$$k_{gg}^2 = \frac{a^2 + c^2}{20}$$

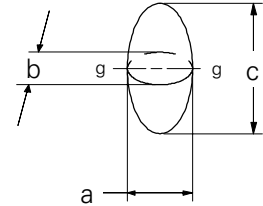

$$k_{gg}^2 = \frac{b^2 + c^2}{20}$$

Torus

$$\text{Weight} = \frac{1}{6} \rho \pi r^2 [3\pi D - 8r]$$

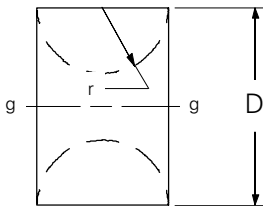

$$k_{gg}^2 = \frac{15\pi D^3 - 120D^2r + 45\pi r^2 D - 64r^3}{60\pi D - 160r}$$

$$\text{Weight} = \rho \pi D r^2$$

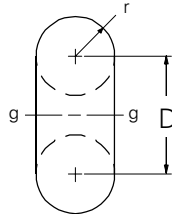

$$k_{gg}^2 = \frac{D^2 + 3r^2}{4}$$

$$\text{Weight} = 2\pi \rho r^2 \left[\frac{\pi D}{4} + \frac{2r}{3} \right]$$

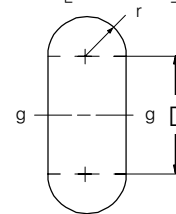

$$k_{gg}^2 = \frac{1}{2} \left[\frac{15\pi D^3 + 12D^2r + 45\pi D r^2 + 6.4r^3}{3\pi D + 8r} \right]$$

Isosceles Triangular Prism

$$\text{Weight} = \frac{a b H}{2} \rho$$

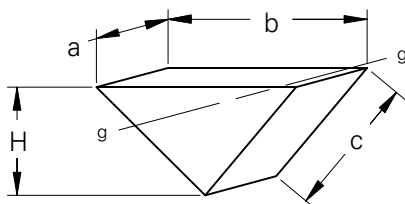

$$k_{gg}^2 = \frac{c^2}{2} - \frac{b^2}{12} - \frac{4H^2}{9}$$

Circular Segment

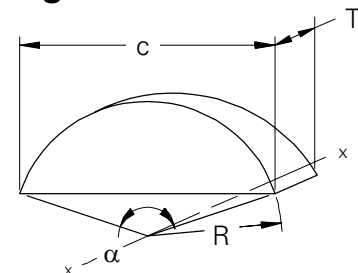

$$W \cdot k_{xx}^2 = \rho T \left[\frac{R^4 \alpha}{229.2} - \frac{1}{6} \left(3R^2 - \frac{c^2}{2} \right) \frac{c}{2} \sqrt{R^2 - \frac{c^2}{4}} \right]$$

Airflex® Motor Armature Wk²

Section Z

APPROXIMATE Wk² (lb ×ft²) OF
NEMA DESIGN B
TOTALLY ENCLOSED FAN-COOLED
MOTORS

(Exact values should be obtained from
manufacturer)

HP	SYNC RPM	Frame	Wk ² (lb · ft ²)	HP	SYNC RPM	Frame	Wk ² (lb · ft ²)
3	1800	182T	0.2	40	3600	324S	3.5
	1200	213T	0.7		1800	324T	7.5
	900	213T	0.9		1200	264T	13.0
			900		365T	14.0	
5	3600	184T	0.2		3600	326TS	4.0
	1800	184T	0.3	50	1800	326T	9.5
	1200	215T	0.8		1200	365T	14.5
900	254T	2.0	900		404T	30.0	
7.5	3600	213T	0.3	60	3600	364TS	8.0
	1800	213T	0.7		1800	364T	12.0
	1200	254T	2.0		1200	404T	27.0
	900	256T	3.0		900	405T	30.0
10	3600	215T	0.4	75	3600	365TS	9.0
	1800	215T	0.9		1800	365T	15.0
	1200	256T	3.0		1200	405T	33.0
	900	284T	3.5		900	444T	49.0
15	3600	254T	0.7	100	3600	405TS	14.0
	1800	254T	1.5		1800	405T	32.0
	1200	284T	3.5		1200	444T	50.0
	900	286T	4.5		900	445T	54.0
20	3600	256T	0.8	125	3600	444TS	27.0
	1800	256T	2.0		1800	444T	44.0
	1200	286T	4.5		1200	445T	55.0
	900	324T	7.5		900	447T	58.0
25	3600	284TS	2.0	150	3600	445TS	32.0
	1800	284T	3.5		1800	445T	54.0
	1200	324T	8.0		1200	449T	64.0
	900	326T	8.0		900	449T	65.0
	3600	286TS	2.0	200	3600	449TS	40.0
30	1800	286T	4.5		1800	449T	77.0
	1200	326T	9.0		1200	449T	73.0
	900	364T	12.0	250	3600	449TS	47.0
					1800	449TS	77.0

Airflex® Wk² for Standard Sheaves

Section Z

APPROXIMATE Wk² (lb · ft²) OF SHEAVES

(Exact values should be obtained from manufacturer)

3V Sheave O.D.	Number of Grooves							
	1	2	3	4	5	6	8	10
2.65	.004	.006	.008	.009				
2.80	.005	.007	.010	.012				
3.00	.007	.010	.012	.014				
3.15	.008	.013	.016	.018				
3.35	.010	.012	.016	.019				
3.65	.013	.019	.024	.030				
4.12	.020	.029	.038	.047				
4.50	.030	.040	.05	.07				
4.75	.033	.05	.07	.08	.10	.13	.17	.20
5.00	.040	.06	.08	.10	.12	.15	.19	.23
5.30	.05	.08	.10	.13	.14	.17	.22	.26
5.60	.06	.09	.12	.14	.18	.20	.26	.30
6.00	.08	.12	.15	.19	.22	.26	.34	.41
6.50	.09	.13	.18	.22	.26	.30	.30	.47
6.90	.12	.18	.24	.29	.35	.40	.52	.60
8.00	.21	.30	.40	.5	.6	.7	.9	1.1
10.60	.60	.80	1.1	1.3	1.6	1.8	2.4	2.9
14.00	1.6	2.0	2.6	3.3	3.9	4.6	5.9	7.2
19.00	4.2	5.2	7.0	8.8	11	12	15	19
25.00		13	17	22	27	31	40	49
33.50			49	61	74	99	117	136

5V Sheave O.D.	Number of Grooves					
	3	4	5	6	8	10
7.10	.5	.6	.7	.8	1.1	
7.50	.6	.7	.8	.9	1.3	
8.00	.7	.8	1.0	1.2	1.5	1.9
8.50	.9	1.1	1.3	1.6	2.0	2.4
9.00	1.0	1.3	1.6	1.9	2.4	2.9
9.25	1.1	1.4	1.7	2.0	2.7	3.2
9.75	1.4	1.7	2.1	2.5	3.2	3.9
10.30	1.6	2.0	2.5	2.9	3.8	4.6
10.90	1.9	2.5	3.0	3.5	4.5	5.5
11.80	2.6	3.3	4.0	4.7	6.2	7.5
12.50	3.1	4.0	4.9	5.7	7.2	8.8
13.20	3.9	4.9	5.9	7.0	9.1	11
14.00	4.7	5.9	7.1	8.3	11	13
15.00	5.9	7.4	9.0	11	14	17
16.00	7.3	9.2	11	13	17	21
21.20	19	24	30	35	44	54
28.00	47	61	73	86	112	138
37.50	125	161	194	229	297	367
50.00	326	417	508	596	775	955

8V Sheave O.D.	Number of Grooves							
	4	5	6	8	10	12	14	16
12.5	8.2	9.8	12	15	20	23	27	32
13.2	8.7	11	12	16	21	25	29	34
14.0	10	13	15	20	27	30	35	42
15.0	13	16	19	25	32	38	44	52
16.0	16	11	24	32	41	49	57	67
17.0	21	26	31	40	51	61	71	83
18.0	26	31	37	48	61	72	85	100
19.0	30	36	33	56	73	87	100	117
20.0	35	43	51	66	85	102	118	138
21.2	43	52	65	84	104	123	143	169
22.4	54	69	81	105	130	155	179	227
30.0	143	176	206	270	355	423	492	577
40.0	381	460	539	717	885	1109	1288	1512
53.0	962	1170	1380	1807	2240	2650	3084	3605
71.0	2719	3321	3990	5220	6450	7679	8890	10440
95.0	6990	9308	10990	14960	18500	22640	26330	31910

Airflex® Wk² for Standard Sheaves

Section Z

APPROXIMATE Wk² (lb · ft²) OF SHEAVES

(Exact values should be obtained from manufacturer)

A Groove Sheave P.D.	Number of Grooves				A Groove Sheave P.D.	Number of Grooves			
	1	2	3	4		1	2	3	4
3.0	010	.011	.016	.021	5.6	.06	.10	.14	.18
3.2	010	.014	.020	.026	5.8	.06	.11	.15	.20
3.4	010	.018	.025	.033	6.0	.07	.12	.18	.23
3.6	013	.022	.031	.040	6.2	.08	.14	.20	.26
3.8	015	.026	.038	.05	6.4	.09	.15	.20	.29
4.0	018	.031	.05	.06	7.0	.12	.20	.28	.38
4.2	022	.037	.05	.07	8.2	.19	.34	.48	.62
4.4	025	.044	.06	.08	9.0	.27	.46	.66	.85
4.6	030	.05	.07	.09	11	.45	.78	1.1	1.4
4.8	034	.06	.08	.11	12	.66	1.1	1.6	2.1
5.0	039	.07	.10	.12	15	1.3	2.3	3.2	4.2
5.2	044	.08	.11	.14	18	2.4	4.1	5.9	7.6
5.4	05	.09	.12	.16	22	4.6	8.1	12	15

C Groove Sheave P.D.	Number of Grooves											
	1	2	3	4	5	6	7	8	9	10	12	
7.0	.32	.49	.7	.8	1.0	1.2						
7.5	.41	.6	.9	1.1	1.3	1.5						
8.0	.5	.8	1.1	1.3	1.6	1.9	2.2	2.4	2.7	3.0		
8.5	.6	1.0	1.3	1.7	2.0	2.4	2.7	3.1	3.4	3.7		
9.0	.7	1.1	1.6	2.0	2.4	2.8	3.2	3.6	4.0	4.4	4.9	
9.2	.8	1.3	1.7	2.2	2.6	3.0	3.5	4.0	4.4	4.8	5.3	
9.4	.9	1.4	1.9	2.4	2.9	3.4	3.8	4.3	4.8	5.3	6.4	
9.5	.9	1.4	1.9	2.4	2.9	3.5	4.0	4.5	5.0	5.5	6.1	
9.6	.9	1.4	1.9	2.5	3.0	3.5	4.0	4.5	5.0	5.5	6.5	
9.8	1.0	1.6	2.1	2.7	3.2	3.8	4.4	4.9	5.0	6.0	6.7	
10.0	1.0	1.6	2.2	2.8	3.4	4.0	4.5	5.1	5.7	6.3	7.0	
10.2	1.1	1.7	2.4	3.0	3.6	4.2	4.9	5.5	6.1	6.7	7.5	
10.5	1.2	1.9	2.6	3.3	4.0	4.7	5.4	6.1	6.8	7.5	8.3	
10.6	1.3	2.0	2.8	3.5	4.3	5.0	5.8	6.5	7.2	8.0	8.9	
11.0	1.5	2.3	3.1	3.9	4.8	5.6	6.4	7.3	8.1	8.9	9.9	
12.0	1.9	3.0	4.1	5.2	6.3	7.4	8.5	9.5	11	12	14	
13.0	2.5	3.9	5.4	6.8	8.2	9.7	11	13	14	15	18	
14.0	3.2	5.0	7.1	8.7	11	12	14	16	18	20	23	
16.0	5.0	7.7	11	13	16	19	22	25	27	31	36	
18.0	6.4	9.9	14	17	21	24	28	31	35	39	46	
20.0	10	16	21	27	32	38	44	49	55	60	72	
24.0	15	24	33	40	49	57	66	74	83	91	108	
27.0		41	56	71	87	102	117	132	147			
30.0		59	81	102	115	147	169	191	213	235	278	
36.0			126	159	193	227	260	293	327	362	428	
44.0			246	313	378	446	512	478	646	712	845	
50.0			371	473	573	673	773	876	974	1076	1278	

B Groove Sheave P.D.	Number of Grooves									
	1	2	3	4	5	6	7	8	9	10
3.4	.012	.025	.033	.042	.051	.059				
3.6	.015	.031	.042	.053	.064	.075				
3.8	.019	.038	.051	.065	.078	.094				
4.0	.023	.045	.062	.078	.095	.11				
4.2	.030	.061	.083	.11	.13	.15				
4.4	.032	.065	.089	.11	.14	.16				
4.6	.040	.076	.10	.13	.16	.19				
4.8	.043	.087	.12	.15	.18	.22				
5.0	.051	.10	.14	.18	.21	.25				
5.2	.058	.12	.16	.20	.25	.29				
5.4	.066	.13	.18	.23	.28	.33	.38	.43	.48	.5
5.6	.073	.15	.20	.25	.31	.36	.41	.47	.5	.6
5.8	.084	.17	.23	.29	.35	.42	.48	.5	.6	.7
6.0	.094	.19	.26	.33	.40	.47	.5	.6	.7	.7
6.2	.10	.20	.28	.35	.43	.5	.6	.6	.8	.8
6.4	.12	.24	.32	.41	.5	.6	.7	.8	.8	.9
6.6	.13	.26	.35	.45	.6	.6	.7	.8	.9	1.0
6.8	.14	.29	.40	.5	.6	.7	.8	.9	1.0	1.2
7.0	.20	.32	.44	.6	.7	.8	.9	1.1	1.2	1.3
7.4	.24	.38	.5	.7	.8	1.0	1.1	1.2	1.4	1.5
8.0	.31	.49	.7	.9	1.0	1.2	1.4	1.6	1.8	2.0
8.6	.39	.6	.9	1.1	1.3	1.6	1.8	2.0	2.3	2.5
9.4	.5	.8	1.1	1.4	1.8	2.1	2.4	2.7	3.0	3.3
11.0	.9	1.4	2.0	2.5	3.1	3.6	4.2	4.7	5.2	5.3
12.4	1.3	2.1	2.8	3.6	4.4	5.2	5.9	6.8	7.5	8.3
13.6	1.7	2.7	3.7	4.7	5.8	6.8	7.8	8.8	9.8	11
15.4	2.5	4.0	5.6	7.1	8.6	10	12	13	15	16
16.0	2.9	4.7	6.5	8.3	10	12	14	16	17	19
18.4	4.3	7.0	9.7	12	15	18	19	23	26	29
20.0	5.5	8.9	12	16	19	22	26	29	32	36
25.0		18	24	31	38	44	51	58	65	72
30.0		39	54	69	84	99	114	129	144	159
38.0		72	100	129	155	183	211	239	267	295

D Groove Sheave P.D.	Number of Grooves									
	3	4	5	6	7	8	9	10	12	
12.0	7.0	8.8	11	13	15	17	18	21	24	
13.0	9.0	12	14	17	19	22	24	27	32	
13.5	10	13	16	19	22	25	28	31	37	
14.0	11	15	18	21	25	28	31	34	41	
14.5	13	17	21	24	28	32	36	39	47	
15.0	15	19	23	28	32	36	41	45	54	
15.5	16	21	26	31	35	40	45	49	59	
16.0	18	23	28	34	39	44	49	54	65	
18.0	25	32	40	47	54	62	69	75	90	
20.0	31	49	59	71	81	93	104	115	136	
22.0	52	68	83	98	113	129	134	159	189	
27.0	110	143	176	209	241	274	307	339	404	
33.0	180	233	286	338	391	445	497	550	654	
40.0	302	391	477	565	655	744	830	915	1090	
44.0				748	864	984	1100	1210	1445	
48.0		738	908	1071	1240	1412	1577	1745	2080	
58.0		1460	1792	2120	2455	2790	3120	3445	4120	

Airflex® V-Belt Dimensions

Section Z

Reference RMA/MPTA IP-20, IP-22, IP26
Dimensions in inches

Belt Size	b_o	h	h_w	E	S
2L	0.25	0.16			
3L	0.38	0.22			
4L	0.50	0.31			
5L	0.66	0.38			
A	0.50	0.31	0.13	0.38	0.63
B	0.66	0.41	0.18	0.50	0.75
C	0.88	0.53	0.20	0.69	1.00
D	1.25	0.75	0.30	0.88	1.44
E	1.50	0.91	0.40	1.13	1.75
3V	0.38	0.31	0.025	0.34	0.41
5V	0.63	0.53	0.05	0.50	0.69
8V	1.00	0.88	0.10	0.75	1.13
V-Ribbed L		0.20	OD=PD	0.38	0.19
V-Ribbed M		0.40	OD=PD	0.50	0.37

Reference ISO Standards R52, R253, R434, R608
Dimensions in millimeters

Belt Size	b_o	h	h_w
Y	6	3	1,3
Z	10	6	2,5
A	13	8	3,3
B	17	11	4,2
C	22	14	5,7
D	32	20	8,1
E	40	25	12

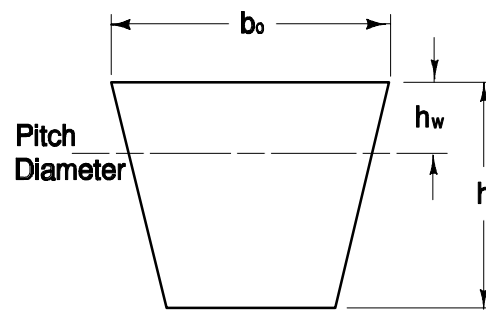

Belt Cross Section

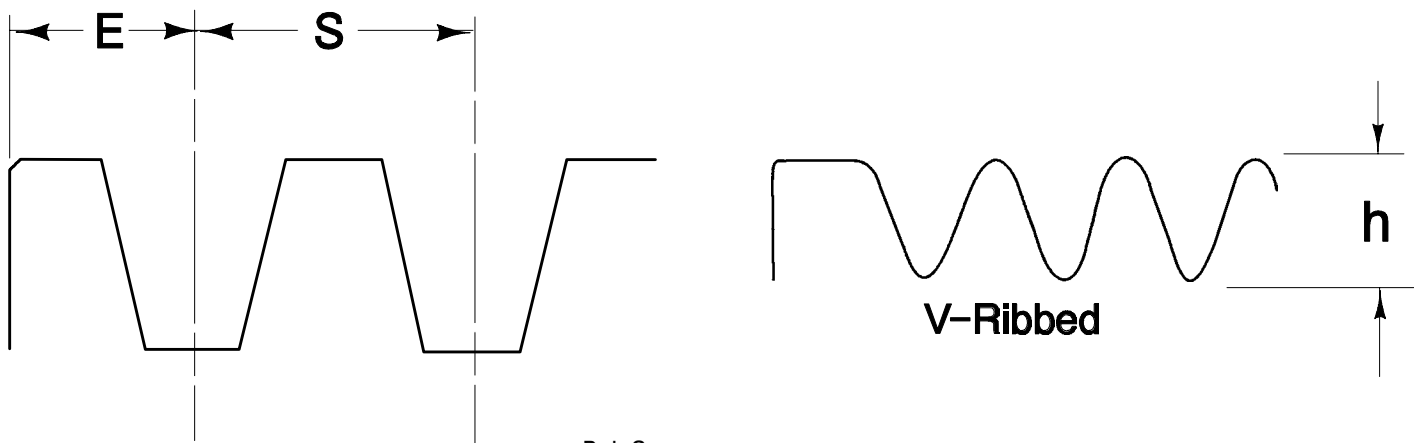

Belt Grooves

Airflex® Torque vs. Shaft Stress

Section Z

Shaft Diameter (in.)	Torque (lb · in) which will produce torsional stress of:		Shaft Diameter (in.)	Torque (lb · in) which will produce torsional stress of:		Torque which will produce a torsional stress of 60 MN/m ²		Torque which will produce a torsional stress of 60 MN/m ²	
	8,000 psi	10,000 psi		8,000 psi	10,000 psi	Shaft Diameter (mm)	Torque (N·m)	Shaft Diameter (mm)	Torque (N·m)
1.000	1,570	1,960	10.250	1,692,000	2,114,000	30	300	170	57,900
1.125	2,240	2,790	10.500	1,818,000	2,260,000	32	400	180	68,700
1.250	3,070	3,830	10.750	1,951,000	2,439,000	35	500	190	80,800
1.375	4,080	5,100	11.000	2,091,000	2,613,000	38	600	200	94,200
1.500	5,300	6,630	11.250	2,237,000	2,796,000	40	800	220	125,400
1.625	6,740	8,420	11.500	2,389,000	2,986,000	42	900	240	162,900
1.750	8,420	10,520	11.750	2,548,000	3,185,000	45	1,100	250	184,100
1.875	10,350	12,940	12.000	2,714,000	3,393,000	48	1,300	260	207,100
2.000	12,550	15,690	12.250	2,888,000	3,609,000	50	1,500	280	258,600
2.125	15,070	18,840	12.500	3,069,000	3,836,000	55	2,000	300	318,100
2.250	17,890	22,370	12.750	3,256,000	4,070,000	60	2,500	320	386,000
2.375	21,040	26,300	13.000	3,451,000	4,314,000	65	3,200	340	463,000
2.500	24,540	30,680	13.250	3,653,000	4,566,000	70	4,000	360	549,700
2.625	28,410	35,510	13.500	3,865,000	4,831,000	75	5,000	380	646,400
2.750	32,670	40,830	13.750	4,083,000	5,104,000	80	6,000	400	754,000
2.875	37,330	46,660	14.000	4,310,000	5,388,000	85	7,200	420	872,800
3.000	42,420	53,020	14.250	4,545,000	5,681,000	90	8,600	440	1,003,500
3.125	47,940	59,920	14.500	4,789,000	5,986,000	95	10,100	450	1,073,500
3.250	53,920	67,400	14.750	5,041,000	6,301,000	100	11,800	460	1,146,700
3.375	60,390	75,480	15.000	5,301,000	6,627,000	110	15,700	480	1,302,900
3.500	67,340	84,180	15.250	5,571,000	6,964,000	120	20,400	500	1,472,600
3.625	74,820	93,530	15.500	5,849,000	7,312,000	130	25,900	530	1150000
3.750	82,830	103,500	15.750	6,137,000	7,671,000	140	32,300	560	1360000
3.875	91,400	114,200	16.000	6,434,000	8,042,000	150	39,800		
4.000	100,500	125,700	16.250	6,740,000	8,425,000	160	48,300		
4.250	120,600	150,700	16.500	7,056,000	8,820,000				
4.500	143,100	178,900	16.750	7,382,000	9,227,000				
4.750	168,800	210,400	17.000	7,717,000	9,647,000				
5.000	196,400	245,400	17.250	8,063,000	10,080,000				
5.250	227,300	284,100	17.500	8,419,000	10,520,000				
5.500	261,300	326,700	17.750	8,784,000	10,980,000				
5.750	298,600	373,300	18.000	9,161,000	11,450,000				
6.000	339,300	424,100	18.250	9,548,000	11,940,000				
6.250	383,800	479,700	18.500	9,946,000	12,430,000				
6.500	431,400	539,200	18.750	10,350,000	12,940,000				
6.750	483,100	603,900	19.000	10,770,000	13,470,000				
7.000	538,800	673,500	19.250	11,210,000	14,010,000				
7.250	597,800	747,200	19.500	11,650,000	14,560,000				
7.500	661,800	827,200	19.750	12,100,000	15,130,000				
7.750	730,200	912,700	20.000	12,570,000	15,710,000				
8.000	803,100	1,004,000	20.250	13,040,000	16,300,000				
8.250	880,800	1,101,000	20.500	13,530,000	16,920,000				
8.500	963,300	1,204,000	20.750	14,030,000	17,540,000				
8.750	1,051,000	1,314,000	21.000	14,550,000	18,180,000				
9.000	1,144,000	1,429,000	21.250	15,070,000	18,840,000				
9.250	1,241,000	1,552,000	21.500	15,610,000	19,510,000				
9.500	1,345,000	1,681,100	21.750	16,160,000	20,200,000				
9.750	1,456,000	1,820,000							
10.000	1,571,000	1,964,000							

Airflex® Shaft Key Standards

Section Z

Reference ANSI B17.1

Dimensions in inches

Shaft Diameter

Over	To	Square Key b=h	Rectangular Key bxh
0.438	0.563	0.125	0.125 × 0.094
0.563	0.875	0.188	0.188 × 0.125
0.875	1.250	0.250	0.250 × 0.188
1.250	1.375	0.313	0.313 × 0.250
1.375	1.750	0.375	0.375 × 0.250
1.750	2.250	0.500	0.500 × 0.375
2.250	2.750	0.625	0.625 × 0.438
2.750	3.250	0.750	0.750 × 0.500
3.250	3.750	0.875	0.875 × 0.625
3.750	4.500	1.000	1.000 × 0.750
4.500	5.500	1.250	1.250 × 0.875
5.500	6.500	1.500	1.500 × 1.000
6.500	7.500	-	1.750 × 1.500
7.500	9.000	-	2.000 × 1.375
9.000	11.000	-	2.500 × 1.625

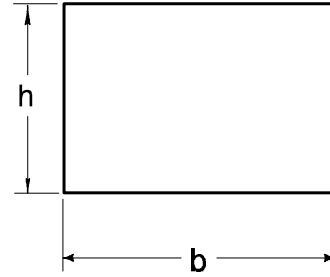

h = key height
b = key width

Reference ISO 773

Dimensions in millimeters

Shaft Diameter

Over	To	Key bxh
6	8	2 × 2
8	10	3 × 3
10	12	4 × 4
12	17	5 × 5
17	22	6 × 6
22	30	8 × 7
30	38	10 × 8
38	44	12 × 8
44	50	14 × 9
50	58	16 × 10
58	65	18 × 11
65	75	20 × 12
75	85	22 × 14
85	95	25 × 14
95	110	28 × 16
110	130	32 × 18
130	150	36 × 20
150	170	40 × 22
170	200	45 × 25
200	230	50 × 28
230	260	56 × 32
260	290	63 × 32
290	330	70 × 36

Airflex® Motor Torque-Speed Characteristics

Section Z

A typical torque - speed characteristic curve for a general-purpose, squirrel-cage induction motor is at the right. It illustrates how motor torque varies as speed increases to synchronous speed.

Four important characteristic points are:

1. STARTING TORQUE
2. PULL-UP TORQUE - the minimum torque developed during the acceleration period from zero speed to the speed at which breakdown torque occurs.
3. BREAKDOWN TORQUE - maximum torque developed without a sharp drop in speed.
4. FULL-LOAD TORQUE - the torque developed at full load speed.

Most motor requirements can be obtained through the use of one of the squirrel-cage polyphase induction motor NEMA classes described below:

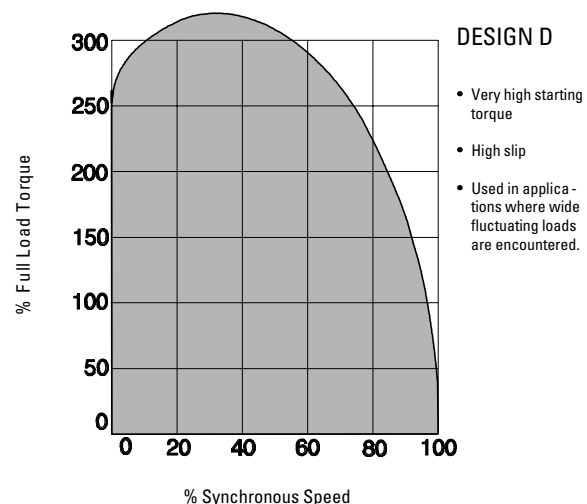
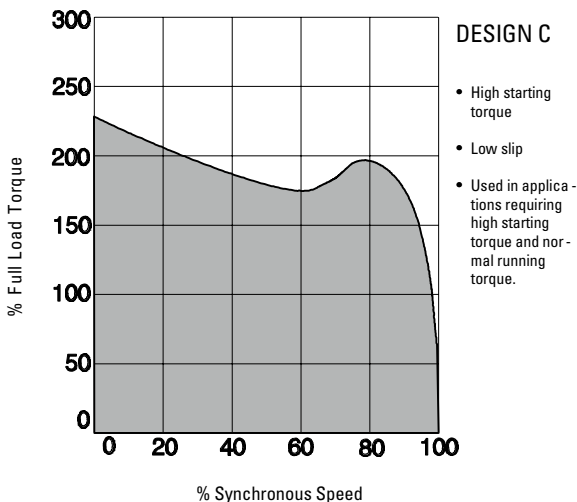
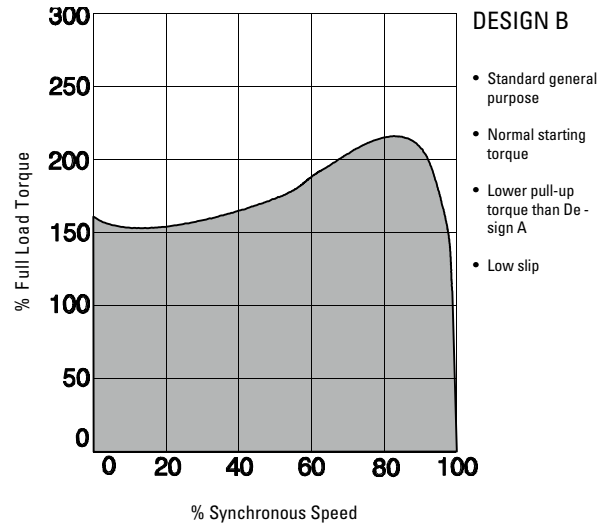
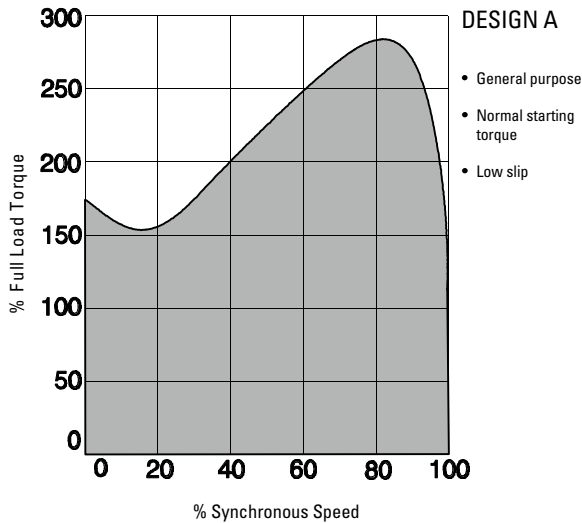
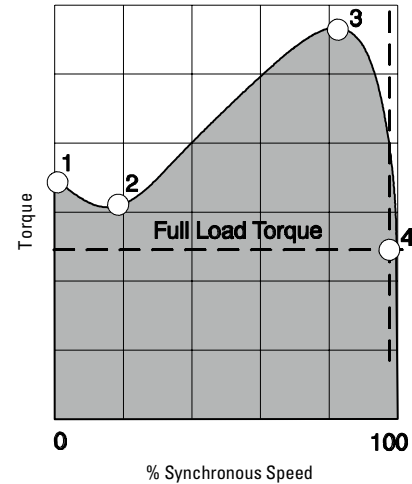

Airflex® Electric Motor Frames

Section Z

NEMA Frame Designations
for Polyphase, Squirrel-cage, Designs A & B Motors

HP	Open Type				Totally enclosed fan cooled			
	3600 rpm	1800 rpm	1200 rpm	900 rpm	3600 rpm	1800 rpm	1200 rpm	900 rpm
0.5				143T-				143T
0.75			143T	145T			143T	145T
1		143T	145T	182T		143T	145T	182T
1.5	143T	145T	182T	184T	143T	145T	182T	184T
2	145T	145T	184T	213T	145T	145T	184T	213T
3	145T	182T	213T	215T	182T	182T	213T	215T
5	182T	184T	215T	254T	184T	184T	215T	254T
7.5	184T	213T	254T	256T	213T	213T	254T	256T
10	213T	215T	256T	284T	215T	215T	256T	284T
15	215T	254T	284T	286T	254T	254T	284T	286T
20	254T	256T	286T	324T	256T	256T	286T	324T
25	256T	284T	324T	326T	284TS	284T	324T	326T
30	284TS	286T	326T	364T	286TS	286T	326T	364T
40	286TS	324T	364T	365T	324TS	324T	364T	365T
50	324TS	326T	365T	404T	326TS	326T	365T	404T
60	326TS	364TS	404T	405T	364TS	364TS	404T	405T
75	364TS	365TS	405T	444T	365TS	365TS	405T	444T
100	365TS	404TS	444T	445T	405TS	405TS	444T	445T
125	404TS	405TS	445T		444TS	444TS	445T	
150	405TS	444TS			445TS	445TS		
200	444TS	445TS						
250	445TS							

Reference IEC 72 Standard Frame Designations

kW	Totally enclosed fan-cooled			
	3000 rpm	1500 rpm	1000 rpm	750 rpm
0,37	71	71	80	
0,55	71	80	80	
0,75	80	80	90S	100L
1,1	80	90S	90L	100L
1,5	90S	90L	100L	112M
2,2	90L	100L	112M	132S
3	100L	100L	132S	132M
4	112M	112M	132M	160M
5,5	132S	132S	132M	160M
7,5	132S	132M	160M	160L
11	160M	160M	160L	180L
15	160M	160L	180L	200L
18,5	160L	180M	200L	225S
22	180M	180L	200L	225M
30	200L	200L	225M	250M
37	200L	225S	250M	280S
45	225M	225M	280S	280M
55	250M	250M	280M	315S
75	280S	280S	315S	315M
90	280M	280M	315M	
110	315S	315S		

Airflex® Motor Frame Dimensions

Section Z

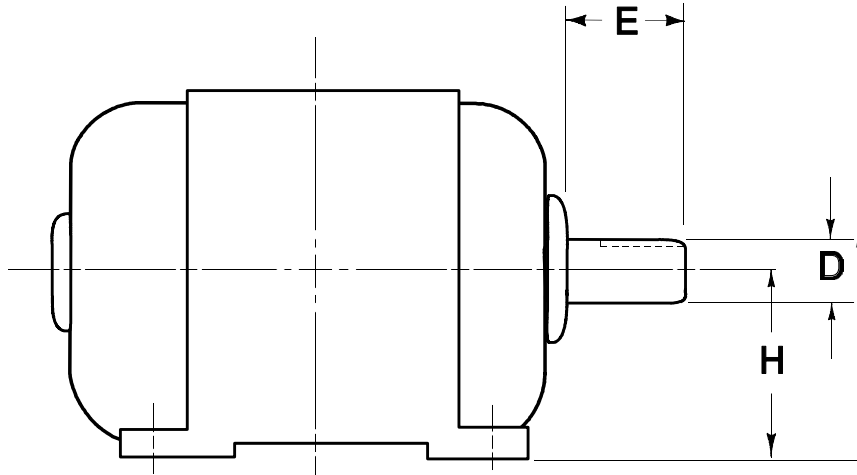

Reference IEC 72 Standard

Frame	DxE	H	Key width x height
71	14 x 30	71	5 x 5
80	19 x 40	80	6 x 6
90S	24 x 50	90	8 x 7
90L	24 x 50	90	8 x 7
100L	28 x 60	100	8 x 7
112M	28 x 60	112	8 x 7
132S	38 x 80	132	10 x 8
132M	38 x 80	132	10 x 8
160M	42 x 110	160	12 x 8
160L	42 x 110	160	12 x 8
180M	48 x 110	180	14 x 9
180L	48 x 110	180	14 x 9
200L	55 x 110	200	16 x 10

Frame	DxE		Frame	DxE	
	3,000 rpm	1500 rpm and slower		3,000 rpm	1500 rpm and slower
225S	55 x 110	60 x 140	225	16 x 10	18 x 11
225M	55 x 110	60 x 140	225	16 x 10	18 x 11
250M	60 x 140	65 x 140	250	18 x 11	18 x 11
280S	65 x 140	75 x 140	280	18 x 11	20 x 12
280M	65 x 140	75 x 140	280	18 x 11	20 x 12
315S	65 x 140	80 x 170	315	18 x 11	22 x 14
315M	65 x 140	80 x 170	315	18 x 11	22 x 14

Notes:

" Shaft tolerance:
for diameters to 48 and inclusive k6.
Other diameters m6.

Airflex® Motor Frame Dimensions

Section Z

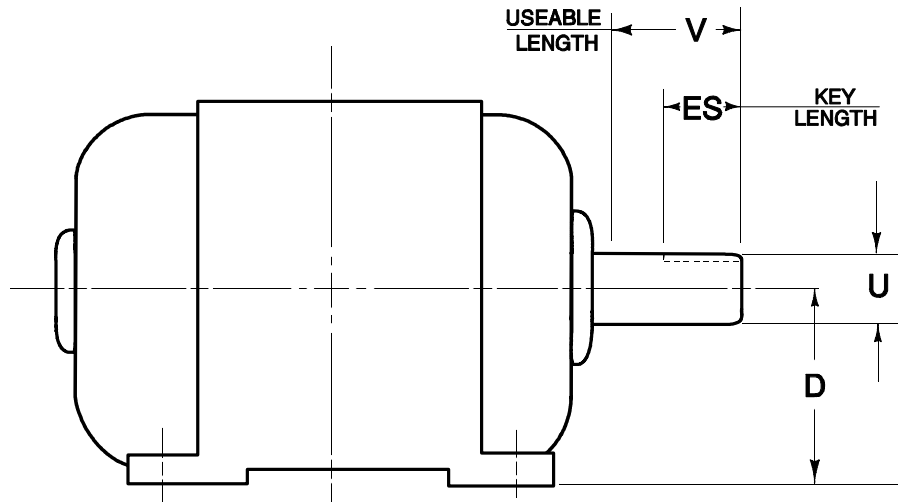

Reference NEMA

Frame No.	D	U	"	V	ES	Square Key
143T	3.50	0.875	"	2.00	1.41	0.19
145T	3.50	0.875	"	2.00	1.41	0.19
182T	4.50	1.125	"	2.50	1.78	0.25
184T	4.50	1.125	"	2.50	1.78	0.25
213T	5.25	1.375	"	3.12	2.41	0.31
215T	5.25	1.375	"	3.12	2.41	0.31
254T	6.25	1.625	"	3.75	2.91	0.38
256T	6.25	1.625	"	3.75	2.91	0.38
284T	7.00	1.875	"	4.38	3.28	0.50
284TS	7.00	1.625	"	3.00	1.91	0.38
286T	7.00	1.875	"	4.38	3.28	0.50
286TS	7.00	1.625	"	3.00	1.91	0.38
324T	8.00	2.125	"	5.00	3.91	0.50
324TS	8.00	1.875	"	3.50	2.03	0.50
326T	8.00	2.125	"	5.00	3.91	0.50
326TS	8.00	1.875	"	3.50	2.03	0.50
364T	9.00	2.375	"	5.62	4.28	0.62
364TS	9.00	1.875	"	3.50	2.03	0.50
365T	9.00	2.375	"	5.62	4.28	0.62
365TS	9.00	1.875	"	3.50	2.03	0.50
404T	10.00	2.875	"	7.00	5.65	0.75
404TS	10.00	2.125	"	4.00	2.78	0.50
405T	10.00	2.875	"	7.00	5.65	0.75
405TS	10.00	2.125	"	4.00	2.78	0.50
444T	11.00	3.375	"	8.25	6.91	0.88
444TS	11.00	2.375	"	4.50	3.03	0.62
445T	11.00	3.375	"	8.25	6.91	0.88
445TS	11.00	2.375	"	4.50	3.03	0.62

Notes:

" Shaft tolerances:

for diameters to 1.500 inclusive +0.000/-0.0005

other diameters, use +0.000/-0.001

Airflex® Air Compressor Requirements

Section Z

General

The following information is to be used as a guide only for preliminary sizing of a compressor. The final compressor size should be determined by the compressor manufacturer.

For determining required compressor capacity for each clutch or brake:

$$Q = \frac{1.5 \cdot p_o \cdot (V_c + V_p) \cdot C}{P_a \cdot 1728}$$

Q = Capacity in cubic feet of free air per minute (CFM).

p_o = Operating pressure in pounds per square inch absolute gage +14.7.

V_c = Cavity volume of element at contact in cubic inches.

V_p = Volume of connecting piping from clutch element to operating valve in cubic inches.

C = Number of engagements per minute.

p_a = Atmospheric pressure (14.7 psi).

1.5 = Factor for wear, decrease of efficiency of compressor and possible leakage in piping.

1 ft³ = 1728 in³

A 24CB500 clutch and brake is used in a drive. The drive is cycled 10 times per minute. Operating air pressure is 75 psi. There is approximately six feet of 1/2 inch piping from valves to elements. Determine compressor capacity and horsepower.

$$Q = \frac{1.5 \cdot p_o \cdot (V_c + V_p) \cdot C}{P_a \cdot 1728}$$

$p_o = 75 + 14.7 = 89.7$ psi

$V_c = 2 \text{ elements} \cdot 200 \text{ in}^3 / \text{element} = 400 \text{ in}^3$

Pipe area • length = $0.304 \text{ in}^2 \cdot 6 \text{ ft} \cdot 12 \text{ in/ft} = 22 \text{ in}^3$

C = 10 cycles/min

$$Q = \frac{1.5 \cdot 89.7 \cdot (400 + 22) \cdot 10}{14.7 \cdot 1728} = 22.4 \text{ CFM}$$

Horsepower Requirement

Horsepower required for single-stage air cooled compressors can be determined from the charts on the next page. Since there is an area where both a single-stage and two-stage unit will satisfy capacity and pressure, use a single-stage unit for 100 psi pressure in sizes up to 1.5 HP. For anything above these limits, use a two-stage unit.

Other Considerations

0.33 TO 1.5 HP compressor - select a unit with 200 percent of calculated average CFM.

2 to 5 HP compressor - select a unit with 175 percent of calculated average CFM.

7.5 to 20 HP compressor - select a unit with 150 percent of calculated average CFM.

Airflex® Air Compressor Requirements

Section Z

Single-stage selection chart

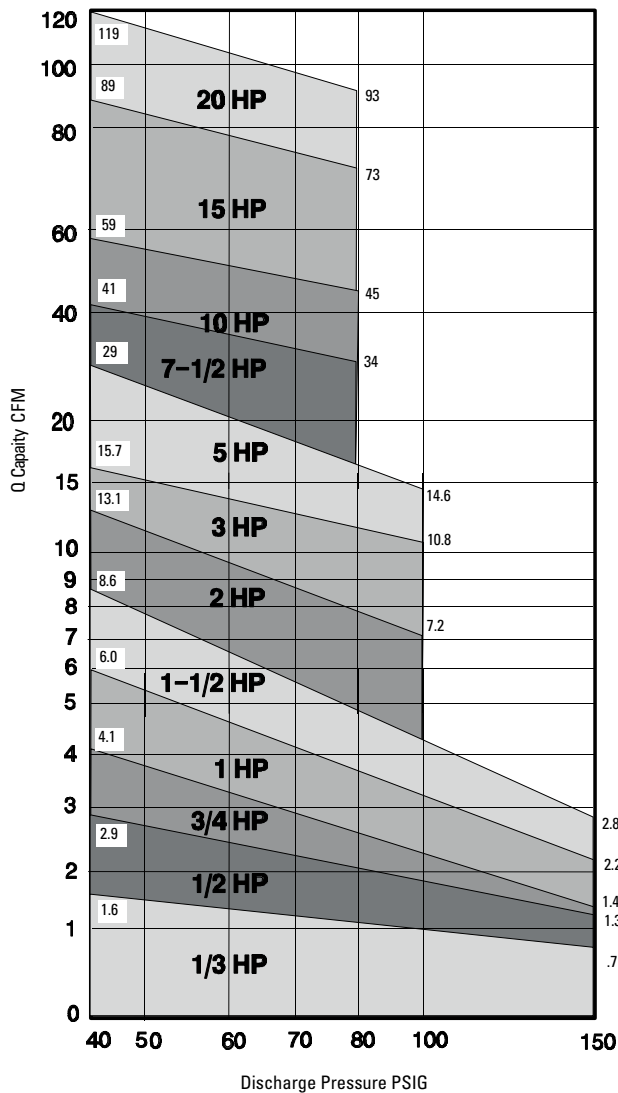

Two-stage selection chart

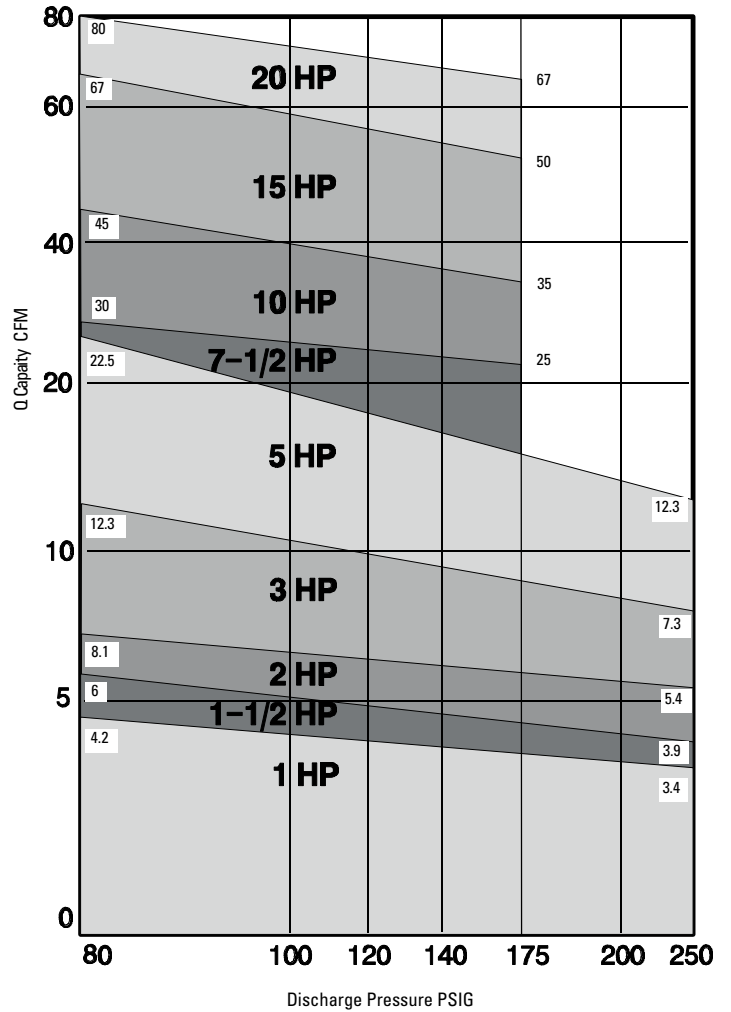

Charts courtesy of Worthington Compressors, Inc.

American National Standard Seamless Wrought Steel Pipe
(Schedule 40) Data (Reference ANSI B36.10)

Size	Threads per inch	Outside Diameter (in)	Inside Diameter (in)	Flow Area (in ²)
1/8	27	0.405	0.269	0.057
1/4	18	0.540	0.364	0.104
3/8	18	0.675	0.493	0.191
1/2	14	0.840	0.622	0.304
3/4	14	1.050	0.824	0.533
1	11 1/2	1.315	1.049	0.864
1	11 1/2	1.660	1.380	1.495
1	11 1/2	1.900	1.610	2.036
2	11 1/2	2.375	2.067	3.355
2 1/2	8	2.875	2.469	4.788

Airflex® Temperature Comparison

Section Z

°F	°C
----	----

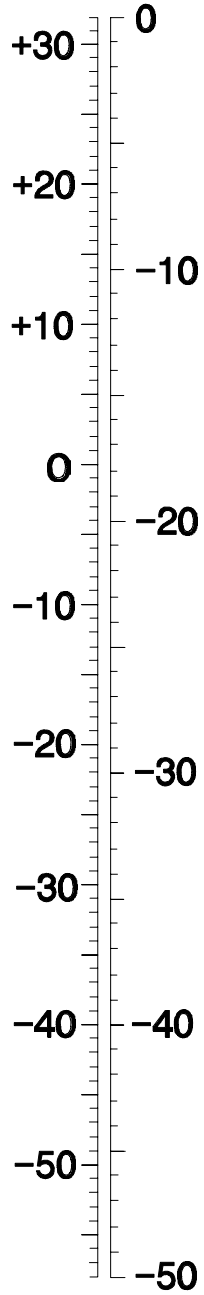

°F	°C
----	----

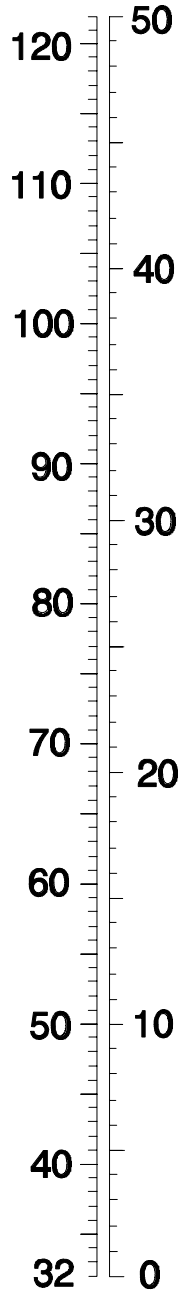

°F	°C
----	----

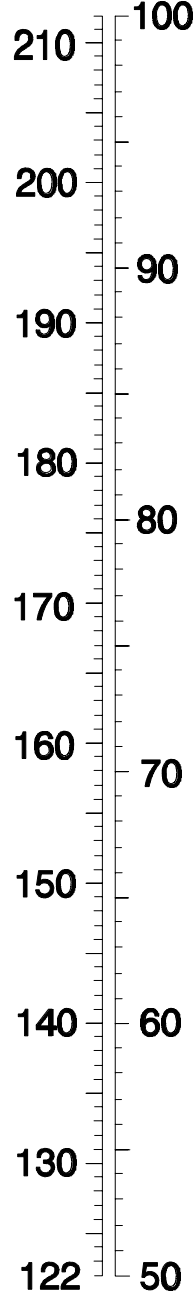

°F	°C
----	----

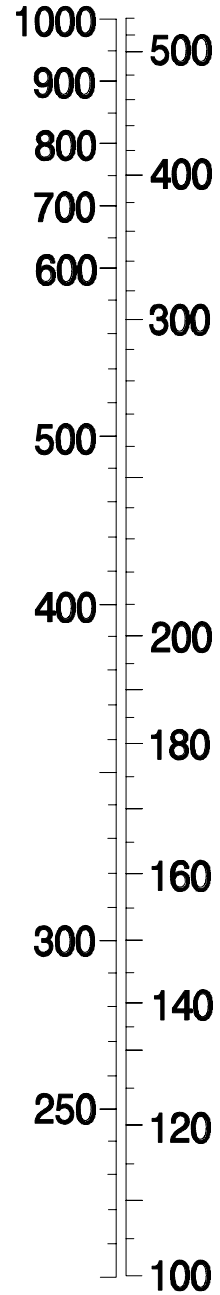

Airflex® Steel Wire and Sheet Gage Numbers

Section Z

Steel Wire Gage (U.S.)

Gage No.	Diameter in inches
7/0	0.4900
6/0	0.4015
5/0	0.4305
4/0	0.3938
3/0	0.3625
2/0	0.3310
1/0	0.3065
1	0.2830
2	0.2625
3	0.2437
4	0.2253
5	0.2070
6	0.1920
7	0.1770
8	0.1620
9	0.1483
10	0.1350
11	0.1205
12	0.1055
13	0.0915
14	0.0800
15	0.0720
16	0.0625
17	0.0540
18	0.0475
19	0.0410
20	0.0348
21	0.0317
22	0.0286
23	0.0258
24	0.0230
25	0.0204
26	0.0181
27	0.0173
28	0.0162
29	0.0150

Manufacturers' Standard Gage for Sheet Steel

Gage No.	Thickness in inches
3	0.2391
4	0.2242
5	0.2092
6	0.1943
7	0.1793
8	0.1644
9	0.1495
10	0.1345
11	0.1196
12	0.1046
13	0.0897
14	0.0747
15	0.0673
16	0.0598
17	0.0538
18	0.0478
19	0.0418
20	0.0359
21	0.0329
22	0.0299
23	0.0269
24	0.0239
25	0.0209
26	0.0179
27	0.0164
28	0.0149
29	0.0135
30	0.0120
31	0.0105
32	0.0097
33	0.0090
34	0.0082
35	0.0075
36	0.0067
37	0.0064
38	0.0060

Airflex 2-Year Warranty

Section Z

Eaton Airflex products proudly carry a two year warranty on all components. This leading warranty is a testament to the high quality of Airflex Industrial Clutches and Brakes. Eaton Airflex quality has been proven with over 70 years of field experience, across multiple markets and countless applications. This warranty serves to provide even further confidence and value in the Airflex brand.

Eaton Corporation (after referred to as "Eaton"), warrants to the original purchaser that products sold shall be free from defects in material and workmanship for 2 years from date of manufacture. If buyer claims that a product violates such warranty, Eaton, upon notice promptly given, will either examine the product at buyer's site, or issue shipping instructions for return to Eaton at buyer's expense, transportation charges prepaid.

Eaton's sole obligation under its warranty shall be, at its option, to repair, replace or refund the price of any product thereof which is proved to violate such warranty. In no event, whether based on contract, indemnity, warranty, tort (including negligence), strict liability or otherwise, shall Eaton be liable to the buyer for special, indirect, incidental or consequential damages whatsoever including, without limitation, loss of profit or revenue. The above warranty is buyer's exclusive remedy and Eaton hereby expressly disclaims all other warranties, express or implied, including the implied warranty of merchantability and the implied warranty of fitness for a particular purpose.

The foregoing shall constitute the sole remedy of the buyer and the sole liability of Eaton. This Limited Warranty shall not apply to any product or component thereof which has been repaired or altered by anyone other than Eaton authorized personnel in any manner so as, in Eaton's sole judgment, to affect its serviceability, or to any product that has been subject to alteration, accident, misuse, abuse, neglect or normal wear.

This Limited Warranty shall not apply to products which have been assembled or installed or used in a manner contrary to Eaton's printed instructions, or due to failure to follow Eaton printed instructions for operation and maintenance. Any technical assistance provided by Eaton's personnel or representatives in system design is construed to be a proposal and not a recommendation.

The responsibility for determining feasibility rests with the user and should be subject to test. Only the terms expressed in this Limited Warranty shall apply and no distributor, corporation or individual is authorized to amend, modify or extend this Limited Warranty in any way on resale.

For product return authorization:

Eaton Corporation
1-888-258-0222

(In Europe)

Eaton Industries Limited
Partnership – EILP
++ 49 (0) 7221 682-0

For additional information contact:

Eaton Aeroquip LLC
Eaton Hydraulics LLC
Eaton Corporation*
1-888-258-0222

Warranty Department

14615 Lone Oak Road
Eden Prairie, MN 55344

Web site: www.eaton.com/hydraulics/warranty

United States

Eaton Corporation
Airflex Division
9919 Clinton Road
Cleveland, Ohio
U.S.A. 44144-1077
Phone: (216) 281-2211
FAX: (216) 281-3890

China

Eaton Hydraulics Group China
Airflex Products
281 Fa Sai Road
WaiGaoQiao Free Trade Zone
Shanghai 200131
China
Tel: (+86 21) 5048 4811
Fax: (+86 21) 5048 4911