



Presto LIFTS
worldwide material handling
and ergonomic solutions

Power Stak

PPS2200-125AS

This manual covers PowerStak units with frame numbers starting with GC stamped into the mast and shipped March 2014 and after.

Installation, Operation and Service Manual

Model Number _____

Serial # _____

Date Placed in Service _____

**IMPORTANT: READ CAREFULLY
BEFORE INSTALLING OR OPERATING LIFT**

Presto Lifts Limited Power Stacker Warranty Policy

Presto Lifts warrants the Power Stacker against defects on the mast, fork carriage, chains, pumps, DC motors, controllers, cylinders and wiring harnesses from faulty material and workmanship for a period of one (1) year from the date of invoice.

All wear items such as batteries, wheels, motor brushes, seals, bearings, hydraulic hoses, all switches, battery chargers and forks have a limited warranty against defects in faulty material and workmanship for a ninety (90) day period from the date of invoice and 30 day limited warranty on labor. Please note that prior authorization from Presto Lifts is required on all warranty work.

There are no implied warranties of any kind, more specifically; there are no warranties of merchantability or fitness for any particular purpose. Presto Lifts' sole warranty shall be as set forth in this limited warranty. Presto Lifts will elect to repair or replace a defective component without charge, if any components should become defective within the limited warranty period. Proof of purchase is required for warranty. The charge for shipping the defective component is the responsibility of the buyer and must be accompanied with an RGA number. The shipping charge to return the component to the buyer is the responsibility of Presto Lifts, Inc.

This limited warranty does not cover labor expense for removal or reinstallation of components after thirty days. This limited warranty shall not cover, among other things: damages resulting from foreign matter or water, failure to provide reasonable and necessary maintenance, and if applicable, use of product while charger is plugged into an AC outlet, or failure to follow operating instructions. The limited warranty is not valid for damage resulting from negligence, accident, unreasonable use, abuse or misuse, exceeding data plate capacities or altering the product without Presto Lifts authorization.

Presto Lifts expressly disclaims and excludes any liability for consequential, incidental, indirect or punitive damages or financial loss to people or property resulting from any breach of warranty or the operation or failure of this product.

Presto Lifts makes no representation that this product complies with local, state, or federal safety/product standards codes. Should this product fail to comply in any way with those codes, it shall not be considered a defect of materials or workmanship. Presto Lifts shall not be held liable for any damages resulting from noncompliance. It is the dealer's responsibility to exercise this limited warranty. This limited warranty is provided to the original purchaser (defined as the original end user) and is nontransferable. This constitutes the complete and final agreement involving Presto Lifts and limited warranty obligations for products.

This manual was current at the time of printing. To obtain the latest, most updated version, please contact the Customer Service Department or go to our website: www.PrestoLifts.com -- you will find a complete list of current Owner's Manuals to print.

TABLE OF CONTENTS

SECTION 1:	
Limited Warranty	2
Wheel Traction and Straddle Leg Set-Up	4
Introduction	5
Responsibility of Owners and Users	6
SECTION 2:	
Certified Operator Training	7
Safety	7
SECTION 3:	
Installation	9
A. Inspection	9
B. Removing from Pallet	9
C. Preparation for Use	9
SECTION 4:	
Operation	10
A. Operating Instructions	10
B. Daily Operations Maintenance Checks	11
Suggested Daily Operator Checklist	12
SECTION 5:	
Battery Maintenance	13
A. Preparing to Charge a Battery	13
B. Charging the battery	13
C. Warnings and Battery Info	13
D. Battery maintenance	13
E. Charger Operations	13
SECTION 6:	
Maintenance	14
A. Weekly Operations Maintenance Checks	14
B. Monthly Operations Maintenance Checks	14
SECTION 7:	
Troubleshooting	15
ORDERING REPLACEMENT PARTS	30
RESTOCKING POLICY	31

LIST OF FIGURES:

Figure 1: Operational Buttons	7
Figure 2: Stacker Body Components	16
Figure 3: Control Pod	17
Figure 4: Steering Component	18
Figure 5: Drive Unit	19
Figure 6: Carriage Assembly	20
Figure 7: Mast Components	21
Figure 8: Power Unit	22
Figure 9: Hydraulic System	23
Figure 10: Hydraulic Schematic	24
Figure 11: Control Panel	25
Figure 12a & b: Electrical Schematic Diagram	26-27
Figure 13: Battery Connection	28
Figure 14: Label Placement	29

CRITICAL PROCEDURE FOR PROPER WHEEL TRACTION

Proper Drive Wheel traction is obtained for the PowerStak Straddle unit using this Procedure

All PowerStak Models are designed and intended to operate on an unfinished concrete floor surface. If any PowerStak is operated on smooth or polished concrete, sealed concrete, epoxy sealed floor, linoleum or other smooth surfaces Drive Wheel traction performance may be affected; If traction issues are encountered Rubber Drive Wheels are available through special order. **Please contact Customer Service at Presto Lifts 1-800-343-9322**

When any PowerStak is operated on a wet, oily, powdery, sandy or non-uniform liquid or granular surface Drive Wheel traction performance will be affected and loss of traction will occur.

SET-UP PROCEDURE FOR POWERSTAK STRADDLE LEGS

NOTE: STRADDLE LEGS MUST BE ADJUSTED IN ACCORDANCE WITH THIS PROCEDURE

1. PowerStak unit located on flat, clean uniform surface, unloaded, forks raised a minimum of 1" off the floor
2. Determine the desired/required straddle width dimension (2 inches greater than pallet width, 1" on each side of the pallet or load, up to a maximum of 50 inches inside width)
3. Be sure to fully loosen all bolts before moving stabilizing legs. Adjust one stabilizer leg at a time – using a pry bar, pinch bar, rubber mallet etc. move the straddle leg out from the base tube to the desired position. Do not move too far, see picture below, if the ¼" wide painted White Line is visible the leg is pulled out too far; Maximum movement 5 ½" for each leg for 2200 pound units.
4. Adjust second Straddle Leg – using a pry bar, pinch bar, rubber mallet etc. move the straddle leg out from inside the base tube to the desired straddle width position.
5. **Straddle Legs must be symmetrically adjusted, both legs adjusted to the same extended dimension!**

CRITICAL – STRADDLE BOLT TIGHTENING SEQUENCE & PROCEDURE

Set up procedure for PowerStak Straddle legs with 5 Bolts:

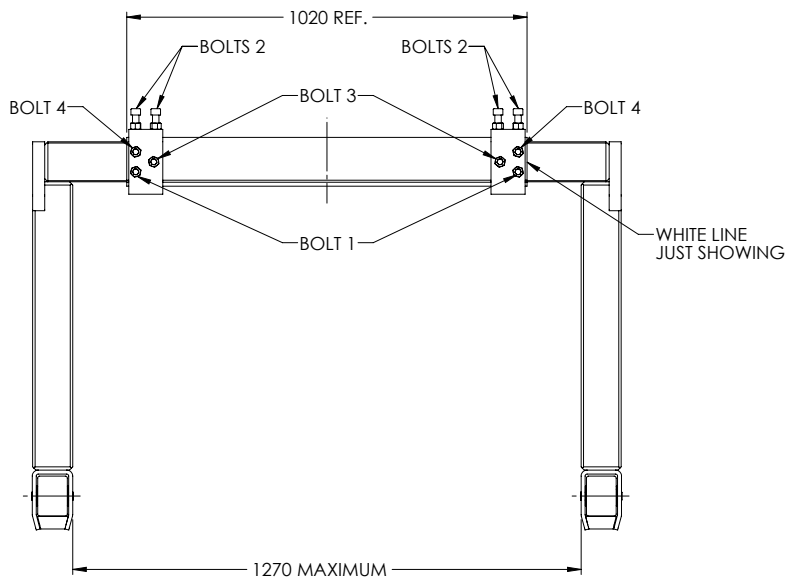

Back off all bolts and follow steps.

- First - tighten Bolt 1 to **85 foot pounds**
- Second - tighten Bolts two (2) to **85 foot pounds**
- Third - tighten Bolt 3 to **85 foot pounds**
- Fourth - tighten Bolt 4 to **25 foot pounds - NOT 85 foot pounds!**
- Last - securely tighten **all lock nuts**



NOTE:
When adjusted correctly, white line cannot be seen.

SECTION 1 INTRODUCTION

This manual attempts to provide all of the information necessary for the safe and proper installation, operation and maintenance of Presto Lifts Inc. battery operated, Power Stak. It is important that all personnel involved with the installation, maintenance or operator of the stacker read this manual. Additional manuals are available upon request or at www.PrestoLifts.com.

Each Presto stacker is equipped with nameplate, serial number and model identifications. Please refer to these numbers when ordering parts or requesting further information.

The Presto stackers are designed for lifting, lowering and positioning a wide variety of loads. WHERE UNIQUE SITUATIONS ARISE, WHICH ARE NOT COVERED IN THIS MANUAL, CALL PRESTO LIFTS FOR FURTHER INSTRUCTIONS.

The battery operated stackers are designed for in-plant/non-hazardous locations only. They can be used in a 8' or larger aisle. These units are not for personnel lifting.

NOTICE

This machine is designed for powered travel and should not be manually moved by applying force to the Control Pod Handles

The Control Pod and steering arm should only be moved side to side when the machine is under power

The Control Pod and steering arm should be lowered to the drive position and power, Forward or Reverse, is engaged by moving the thumb wheel in the direction of desired travel then the steering arm can be moved side to side for directional steering.

Pushing or pulling on the Control Pod Handles when the unit is not powered can lead to damage and/or breakage

⚠ WARNING	LIFTING CAPACITY ABOVE 7' IS LIMITED		
To avoid bodily injury read, understand and follow all instructions before operating this machine.	Maximum Lifting Capacity		
	UP TO 7' 2,200 LBS.	UP TO 8' 1,800 LBS.	UP TO 10' 1,500 LBS.
	<small>Ratings based on 24" Load Center See Owner's Manual for details</small>		

Responsibility of Owners and Users

Inspection and Maintenance

The device shall be inspected and maintained in proper working order in accordance with Presto's owner's manual.

Removal from Service

Any device not in safe operating condition such as, but not limited to, excessive leakage, missing rollers, pins, or fasteners, any bent or cracked structural members, cut or frayed electric, hydraulic, or pneumatic lines, damaged or malfunctioning controls or safety devices, etc. shall be removed from service until it is repaired to the original manufacturer's standards.

Repairs

All repairs shall be made by qualified personnel in conformance with Presto's instructions.

Operators

Only trained personnel and authorized personnel shall be permitted to operate PowerStak.

Before Operation

Before using the device, the operator shall have:

- Read and/or had explained, and understood, the manufacturer's operating instructions and safety rules.
- Inspected the device for proper operation and condition. Any suspect item shall be carefully examined and a determination made by a qualified person as to whether it constitutes a hazard. All items not in conformance with Presto's specification shall be corrected before further use of the PowerStak.

During Operation

The device shall only be used in accordance with this owner's manual.

- Do not overload.
- Ensure that all safety devices are operational and in place.

Modifications or Alterations

Modifications or alterations to any Presto industrial positioning equipment shall be made only with written permission from Presto.

SECTION 2

CERTIFIED OPERATOR TRAINING

You must be trained and certified to operate this powered stacker. Federal law states that only properly trained operators are permitted to operate a powered industrial stacker and that your employer must train you and certify that you are qualified. (OSHA 1910.178 29QFR-7-1-06 Edition)

Presto lifts does not offer operator training. Operator training programs may be offered by your local Presto Lifts dealer or obtained online. Enter, "powered industrial truck operator training" into a search engine.

SAFETY ALERT SYMBOLS AND SIGNAL WORDS

The safety of all persons operating, maintaining, repairing, or in the vicinity of this equipment is of paramount concern. This is a powerful machine with moving parts, and is capable of causing personal injury if proper precautions are not taken. Therefore, throughout this manual, certain hazards have been identified which may occur in the use of the machine, and there are appropriate instructions or precautions which should be taken to avoid these hazards. In some cases, there are consequences which may occur if instructions or precautions are not followed. Below are the symbols and signal words along with their definitions referenced from ANSI Z535.4 - Product Safety Signs and Labels.

Safety Alert Symbols

These are the safety alert symbols.. They are used to alert you to potential physical injury hazards. Obey all safety messages that follow this symbol to avoid possible injury or death.



For use with DANGER signal word
(Red Background)



For use with WARNING signal word
(Orange Background)



For use with CAUTION signal word
(Yellow Background)

Signal Words

The meaning of different signal words as defined by ANSI Standard Z535.4 indicates the relative seriousness of the hazardous situation.



(Red Background)

DANGER indicates a hazardous situation which, if not avoided, will result in death or serious injury.



(Orange Background)

WARNING indicates a hazardous situation which, if not avoided, could result in death or serious injury.



(Yellow Background)

CAUTION, used with the safety alert symbol, indicates a hazardous situation which, if not avoided, could result in minor or moderate injury.



(Blue Background)

NOTICE is used to address practices not related to personal injury.



(Green Background)

SAFETY INSTRUCTIONS (or equivalent) signs indicate safety-related instructions or procedures.

The battery operated stackers are very powerful lifts capable of doing large amounts of work.

DO NOT OPERATE THESE LIFTS WITHOUT CAREFULLY READING THIS MANUAL. In order to provide for the safe operation of these stackers, Presto Lifts Inc. has identified certain hazards that may occur during the maintenance and use of these lifts. For safety reasons these units are designed to be serviced or repaired in the fully lowered position. If performed properly, this will greatly reduce the possibility of injury.

WARNING

When servicing the unit:

1. Key should be in "OFF" position.
2. E-stop should be depressed.
3. Disconnect the batteries at the terminals.
 - Do not perform any repair work on lifts if there is a load on the forks or platform.
 - Do not perform any repair work if the forks or platform is in the raised position.
 - All personnel must stand clear of the lift while in motion.
 - Do not put hands or feet under the forks or platform.
 - Do not stand underneath the forks or platform.
 - Do not stand in front of the stacker while in motion.
 - Do not stand, sit or climb on the lift.
 - Do not use the lift on soft, uneven or unstable surfaces.
 - Do not exceed the load center or capacity.

WARNING

You or others around you can be seriously injured or even killed if you don't use this stacker correctly. Read and obey all warnings and instructions in this manual and on the stacker. It is your responsibility before starting work to make sure it is in good working order.

Always be alert to the area around you and watch where you are walking. Be careful that you don't get pinned or crushed between the stacker and a fixed object such as a wall or post.

- Watch your hands and feet. A foot or hand caught between the stacker and a fixed object will be crushed or even cut off.

- If traveling forks first, keep both hands on the control handle and be careful when changing direction of travel. Keep your feet clear of the stacker.
- Keep the stacker under control at all times. Operate at a speed that allows you to stop safely. Be even more careful on slippery or uneven surfaces. Do not run over objects on the floor.
- Perform all stacker movements smoothly and at a speed that will give you time to react if an emergency occurs.

Tipovers and falls are very serious accidents; you can be crushed or even killed. To prevent injury, know where you are at all times and follow the rules of safe stacker operation.

- Be careful when working around docks, dockboards and trailers. Stay away from the edge of docks and ramps. Check to make sure the wheels of truck or trailers are chocked.
- Travel with the load or forks close to the ground. Watch for overhead obstructions. Perform all stacker movements smoothly and at a speed that will give you time to react in an emergency.
- Keep your hands and feet away from all moving parts such as masts, chains, forks or wheels.
- Never stand on or under the forks, or allow anyone else to stand on or under them. Never ride on the stacker or allow anyone else to ride. There is no safe place to sit or stand.
- Before you leave your stacker, be sure to lower the forks to the floor. Shut the stacker off with the key.

WARNING

- DO NOT** use this stacker until you have been trained and authorized to do so.
- DO NOT** operate until you have read all warnings and instructions.
- DO NOT** exceed load center or load weight capacities (check capacity plate).
- DO NOT** operate until you have checked the conditions of the stacker: lift systems, forks, chains, and cables.
- DO NOT** use if any part is damaged, worn or not working properly.
- DO NOT** use on ramps or inclines. Only smooth level surfaces.
- DO NOT** use for lifting or carrying people.
- DO NOT** handle unbalanced, unstable or loosely stacked loads.
- DO NOT** travel with forks or platform in an elevated position.
- DO NOT** handle tall, unsecured or unstable loads that could fall.
- DO NOT** allow people to stand or pass under forks or platform with or without load.
- DO NOT** operate when parts of anyone's body may be close to mast structure or any moving parts.
- DO NOT** drop loads on platform or forks.
- DO NOT** alter or modify this stacker in any way.

SECTION 3 INSTALLATION

A. INSPECTION:

Upon receipt of the stacker, inspect the equipment completely to determine if there is any shipping damage, and that the lift is complete. Presto tests and inspects every piece of equipment prior to shipment. If damage is apparent, a freight claim must be filed with the freight company. Do not use the stacker if there appears to be any damage. With the stacker in a lowered position, check the following:

- Check for signs of damage especially to the back cabinet that houses the battery, electrical/hydraulic power pack.
- Check all electrical and hydraulic connections for tightness.
- Remove back panel.
 1. Turn key switch to "OFF" position.
 2. Push in E-stop and unscrew the red knob,
 3. Lift off back panel. There is enough wire

to the key switch to allow the panel to be set aside.

- Inspect for any bent or damaged parts.

B. REMOVING FROM PALLET

PowerStak is shipped out on a pallet or skid. Prior to removing the unit from the pallet or skid, remove all tie down straps and packaging. Visually inspect the unit as closely as possible.

With an overhead hoist or forklift, carefully pick up the unit taking into consideration the center of gravity of the unit. If you choose to pick the unit with an overhead hoist, use a nylon sling and hoist with a minimum of 2,000-lb. capacity. The nylon sling will not do any damage to the steel construction of stacker. Pick the unit up. On conventional masts use the top crossmember of the lift. On narrow masts the cover must be removed to access lifting equipment. Be careful of the stacker swinging once fully lifted off the pallet or skid. Have all personnel completely cleared from the area. Pick the unit up approximately six inches above the pallet or skid. Once raised, remove the pallet or skid from below the lift. Do not move the lift around in the air. Lower the stacker on the ground.

C. PREPARATION FOR USE

PowerStak left our factory in new condition. It has been inspected and weight tested to assure all performance standards have been met.

Visually inspect the stacker for damage. Check for attachments and accessories that may have been ordered. If there is any damage or missing parts, report it to your carrier and your Presto dealer immediately.

Remove all metal/plastic bands, cardboard and other material used for shipping purposes.

Check to see if chains are in place, and that the lift system is in working order. Inspect for oil leaks.

Connect battery cable. Check cables and wires on battery charger as well as battery.

Note: The travel speed is preset at the factory. For travel speed adjustment, please contact customer service at Presto Lifts 1-800-343-9322

SECTION 4

OPERATION

A. OPERATING INSTRUCTIONS:

To Raise and Lower:

There are two buttons located on both sides of the handle. The inside one is for lowering the forks. The outside one is for raising the forks. When operating, always make sure the load being lifted is within the loading capacity of your stacker and the load has been stacked safely on the pallet. Also, make sure that the length of the forks corresponds to the length of the pallet. In this way, the load rollers will place themselves in the opening at the end of the pallet, so that when you raise the forks, you will not break the bottom boards of the pallet. Always make sure that when entering the pallet that the forks are in the fully lowered position. Be careful when lifting pallets that are too short or too long for the stacker. It might destroy your pallet by breaking the bottom boards, and if the forks project through the end of the pallet, the tips of fork may go into the next pallet that is behind the pallet that you are lifting, which may bend the tips of forks and overload the capacity of the stacker.

Travel Function:

To travel, rotate the butterfly controls throttle on the upper part of the handle. When rotating the butterfly control towards the forks, the stacker runs forwards in the

forks first direction. When rotating the butterfly towards the operator, the stacker runs in the reverse direction. Always make sure the stacker clears any obstruction when traveling, and that your path of travel is clear of people. Never carry loads above the loading capacity of the stacker. It is suggested that when traveling without a load, the forks be in the lowered position. The speed of the stacker is increased by the degree of the rotation in either direction; it functions like a throttle. When you release your hand from the butterfly control, it automatically will resume to the neutral position and the speed of the stacker will slow down, and come to a stop.

Turtle Speed Travel:

When the butterfly control is engaged forward (toward the forks) or reverse (toward the operator if the operator simultaneously engages the turtle speed button the forward and/or reverse speed is limited to 50% of full speed or turtle speed.

The operator can engage the butterfly forward with the right hand and engage the turtle speed button with the left hand.

The operator can engage the butterfly forward with the left hand and engage the turtle speed button with the right hand.

The reverse operation is also controlled with either hand.

The turtle speed is maintained only when the turtle speed button is engaged. When the turtle speed button is not engaged the unit will operate at full speed. The turtle speed button is a maintained contact operation.

Figure 1: Operational buttons

Control Pod Top

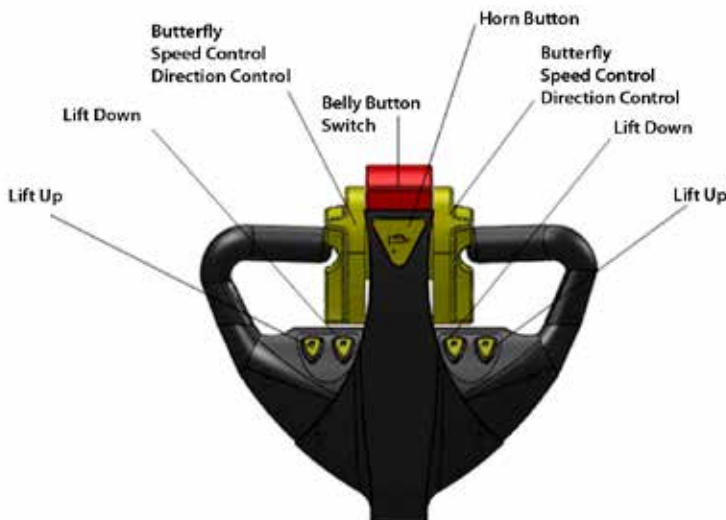

Control Pod Bottom



Electric Brake:

Your stacker is equipped with an electric magnetic brake. The brake is applied when the handle is in its vertical position between 10 – 15 degrees and lowered position between 80 – 90 degrees. The brake could be released when you pull down the handle at any point between 15 – 80 degrees. Always make sure the brake is released before operating the stacker. When the stacker is running, you could brake the stacker by raising the handle to its vertical position or lowering the handle to its lowest position. Or, to turn the butterfly controls in the opposite direction, the change in direction of the motor will slow down, stop, and reverse the direction of stacker. **When parked**, the handle will spring back to the full vertical position with the brake applied and the forks in lowered position.

Reversing Safety:

At the end of the handle there is a large, red reversing bar (belly button switch) that is designed to protect the operator from injury. When the operator runs the stacker backwards, and the end of the handle comes in contact with the operator's body, the stacker will automatically reverse direction and travel away from the operator. When the reversing safety bar comes in contact with your body during operation, immediately release your hands from the butterfly control and put the handle up to its vertical position or down to its lowest position and the brake is on. The reversing safety bar will automatically resume to its original position after being activated.

Horn:

As standard equipment, a horn that is located on the top of the handle.

AUTHORIZED OPERATORS SHOULD READ AND UNDERSTAND ALL INSTRUCTIONS, PRECAUTIONS AND WARNINGS. IMPROPER USE OF THIS LIFT TRUCK COULD RESULT IN INJURY AND/OR DAMAGE TO LOAD AND EQUIPMENT.

- Inspect the lift for damaged or worn parts.

Do not use if not in safe operating condition.

- Use lift on hard level surfaces only.
- Make sure load is evenly distributed, not loose or unstable, and is as far back on platform or forks as possible. *Do not* pick up loads on tips or forks or edge of platform.
- For fork models, adjust forks to the maximum practical width. Pick up loads on both forks.
- *Do not* overload. Check load center and load weight capacities on the nameplate.
- Make sure travel and work area is clear of obstructions.
- Check overhead clearance before lifting loads or transporting.

B. DAILY OPERATIONS**MAINTENANCE CHECKS:****1. Battery**

- A. Check for corroded and loose terminals. A white powder substance will be present if there is any existing corrosion.
- B. Visually inspect for any cracks or damage to the casing.
- C. Check for loose battery tie-downs.

2. Charger

- A. Inspect wire connections.
- B. Check power cord for nicks/damage.
- C. Check power charger for proper mounting.

3. Hydraulic System

- D. Inspect pump and cylinder for oil leaks.
- E. Check hydraulic oil level.
- F. Check hydraulic fittings and hoses.
- G. Check ram for nicks/damage.

4. Frame Assembly

- A. Check chain roller assembly connections.
- B. Check for any worn or damaged parts.

DAILY OPERATOR CHECK LIST

CHARGE CONDITION/BATTERY CHECK LIST

1. Check Battery Discharge Indicator (Fuel Gage and Hour Meter) – Be sure unit is showing **proper Charge Level** before operating unit
2. Check to be sure **Charging Cord** is **Unplugged** and properly stowed before operating unit
3. Inspect Battery Wire Connections – All connections should be tight with **No Corrosion** (white powder) showing at the **Battery Terminals**
4. Inspect Battery Case – There should be **no cracks or visible damage** to the **Battery Case**

WALK AROUND INSPECTION

1. Check general condition of Stacker (loose or broken parts, oil, dangling wires, dents, cracked covers etc.)
2. Check metal frame, mast, carriage and front load supports for cracked welds, worn or flat rollers, loose or disconnected chains, loose pins, missing snap rings, and loose or missing hardware – bolts, nuts washers etc.
3. Check for evidence of hydraulic leaks
4. Make sure all precautionary labeling is in place and legible

FUNCTIONAL INSPECTION

1. Check Drive – Forward and Reverse Function
2. Check Lift – Up and Down Function
3. Check Function for Belly Button Reverse
4. Check Horn Function
5. Check Brake Function

OPERATOR ID _____ DATE _____

DO NOT USE OR OPERATE STACKER IF ANY FUNCTION IS NOT OPERATING PROPERLY OR IF STACKER APPEARS UNSAFE IN ANYWAY

REPORT CONCERNS TO SUPERVISOR IMMEDIATELY!

SECTION 5

BATTERY MAINTENANCE

A. PREPARING TO CHARGE A BATTERY

1. Always turn off E-stop and key switch before working with the batteries.
2. Be sure the area around the stacker and the battery is well ventilated while battery is being charged.
3. The battery terminals, connections and wiring connections should be clean and free of corrosion. When cleaning any of these components wear a face shield or other suitable protective eyewear.

B. BATTERY CHARGING

Charging must be performed with the charger that is provided with or prewired into the machine. During charging, the temperature in the battery must not exceed 120 F. Charging simultaneously with truck operation is not recommended. Plug the charger into a 115 volt outlet. Charge until the battery gauge indicator lights show fully charged (approximately 6-8 hours).

C. WARNINGS AND BATTERY INFORMATION

Avoid use of open flame near batteries. At temperatures around freezing point, battery capacity is reduced by 30%. The battery terminals, connections and wiring should be clean and free of corrosion. When cleaning any of these components, wear a face shield or other suitable protective eyewear. Read, understand, and follow all battery and battery manufacturer's specific precautions while working with and/or charging batteries.

D. BATTERY MAINTENANCE

To measure the voltage, use a digital voltmeter (DC) on the battery poles. The truck must not have been in use for the previous 30 minutes.

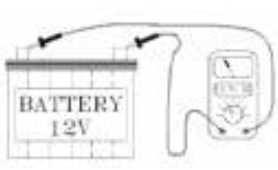

VOLTAGE	
Approx. 12.7 V	Fully charged
Approx. 12.2 V	1/2 charged
Approx. 12.0 V	1/4 charged
Approx. 11.6 V	Discharged



Never alter the AC cord or plug provided. If it will not fit outlet, have proper outlet installed by a qualified electrician. Improper connection can result in a risk of an electric shock.

1. Disconnect the charger from the 115 volt wall outlet once the indicators read fully charged.

E. CHARGER OPERATION

LED Instruction:

Red light on: Charge error (Voltage <11V)

Red flashing light: Battery reversed polarity

Yellow flashing light: No battery connected

Yellow light on: Normal charging

Green flashing light: 80% charged

Green light on: Fully charged



Battery Discharge Indicator (BDI)

Operation

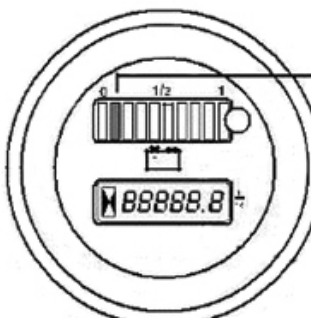

Here, second from left LED blinks indicating reserved power is above 70%

At this point we recommend charging the system

Two leftmost LEDs blinking indicate **EMPTY**

RECOMMEND charging the system BEFORE the BDI indicates EMPTY IN ORDER TO EXTEND BATTERY LIFE

SECTION 6

MAINTENANCE

Operation of Presto Power Stak is very simple — as is their construction. They require very little maintenance. Reasonable care will result in excellent trouble-free performance. The Power Stak is designed for one-man operation and ease of performance.

- Grease floor wheels and casters at least once a month
- Use only Hydraulic Oil AW32 or Dextron III in the hydraulic system.
- *Do not* overload your lift.
- Check brakes, steering mechanisms and controls before each use.

A. WEEKLY OPERATIONS MAINTENANCE CHECKS:

DAMAGE: Check for bent, dented, worn or broken parts.

LIFT SYSTEM: Check to assure that there is no binding or excessive play in the forks. Check for quiet and smooth operation of the lift cylinder. Check all moving parts and linkage.

LEAKS: Check hydraulic system for leaks and hydraulic oil level.

WHEELS AND CASTERS: Check for wear and that they are turning smoothly.

LIFT CHAINS: Check to see that they are in place and not loose.

FORKS: Check that they are not bent or cracked.

BRAKE: Ensure the brake works properly.

CABLES; WIRES: Check that there are no loose cables or wires.

LABELS: Ensure all precautionary labels and guards are in place.

B. MONTHLY OPERATIONS MAINTENANCE CHECKS:

1. Battery (maintenance free)

- A. Clean terminals.
- B. Clean battery compartment area if there are signs of corrosion.

2. Hydraulic System

- A. Clean and inspect hydraulic cylinder.
- B. Lubricate chain with a rust inhibitive lubricant (light machine oil).
- C. Check chain tension. It should be even on both chains. The chain should be tight enough so that it does not come off of the roller assembly.

3. Frame Assembly

- A. Clean and lubricate all roller bearings, cam followers and all moving parts.
- B. Clean and inspect all welds.
- C. Check wheels for wear and damage.
- D. Inspect nameplate for legibility. Place the serial and model number shown on the nameplate on the cover of the manual for future reference.

4. Electrical

- A. Check batteries, motors, controllers, limit switches, electrical conductors and connections.



**DO NOT USE LIFT IF IT IS NOT
OPERATING PROPERLY,
OR APPEARS UNSAFE IN ANY WAY!**

SECTION 7

TROUBLESHOOTING

Before starting the troubleshooting, you have to:

- A. Put the truck on an even and solid surface.
- B. Turn off key switch or disconnect the battery terminals.

1. Unit will not lift (motor does not run)

- Faulty wiring from fuse to lift switch in handle
- Faulty lift switch
- Faulty wiring from battery positive terminal to pump contactor to pump motor
- Burned out brushes in pump motor
- Low hydraulic pressure caused by:
 - Pressure relief valve needs adjustment
 - Pump check valve stuck open
 - Faulty solenoid valve
- Faulty wiring from lift switch to solenoid
- Faulty lift contactor
- Defective control circuit fuse
- Chain or roller bound
- Check oil level

2. Forks will not lower

- Look for binding in chains or rollers

3. No electrical power

Dead Batteries:

- Keyswitch on "OFF" position
- E-stop button depressed
- Loose or dirty battery connections
- Blown fuse(s)
- Faulty wiring from fuse to travel control switch
- Faulty control switch
- Faulty wiring from travel control switch direction contactor
- Faulty contactor

Figure 2: Stacker Body

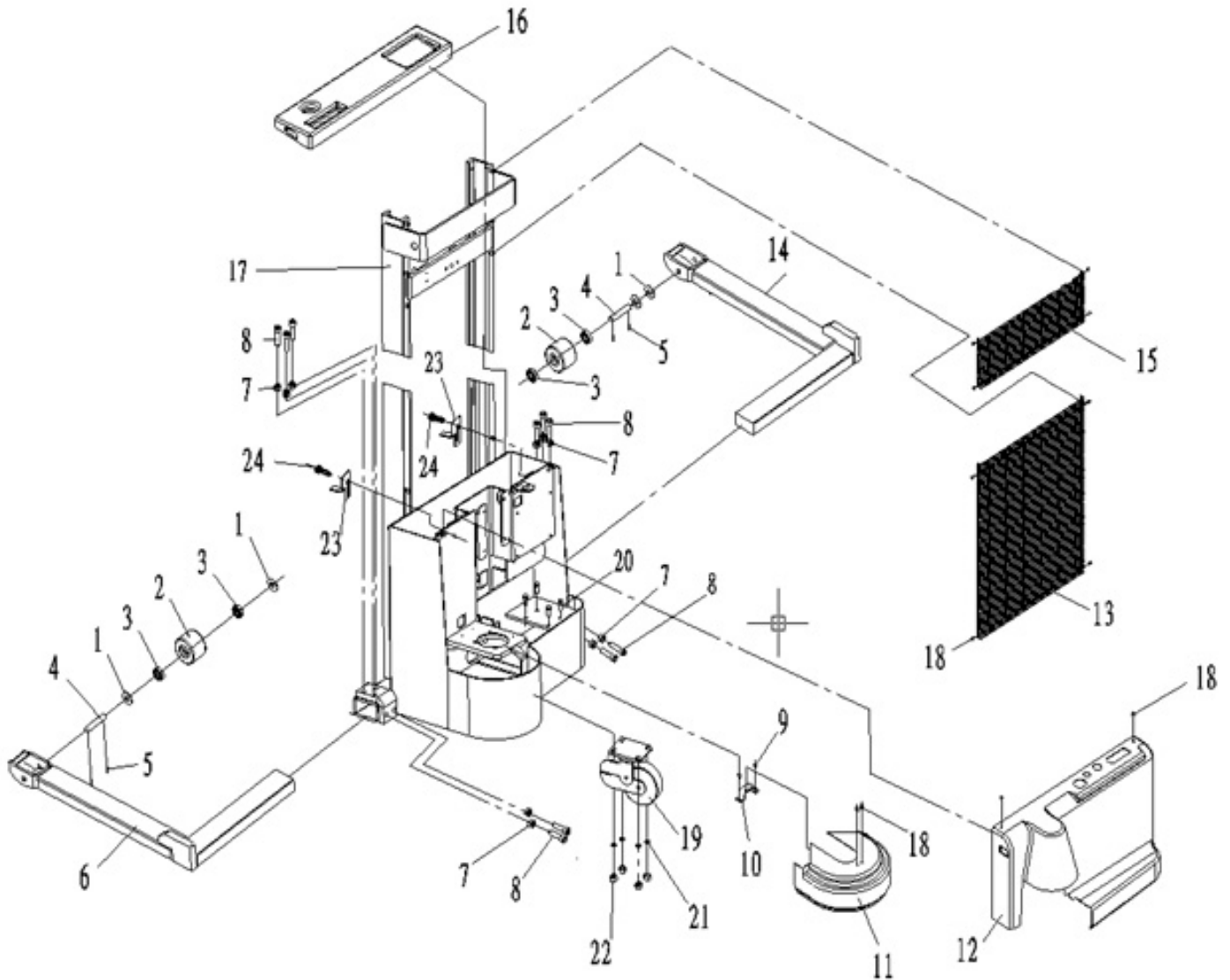

Item	Description	Qty
1	Spacer	4
2	Load Wheel	2
3	Bearing	4
4	Spindle	2
5	Bolt	4
6	Straddle Leg (LH)	1
7	Nut	10
8	Bolt	10
9	Bolt	2
10	Seat	1
11	Drive Wheel Cover	1
12	Rear Cover	1

Item	Description	Qty
13	Screen	1
14	Straddle Leg (RH)	1
15	Screen	1
16	Top Cover	1
17	Stacker Body Assembly	1
18	Screw	14
19	Caster Assembly	1
20	Bolt	4
21	Spring Washer	4
22	Nut	4
23	Bracket	4
24	Bolt	4

Figure 3: Control Pod

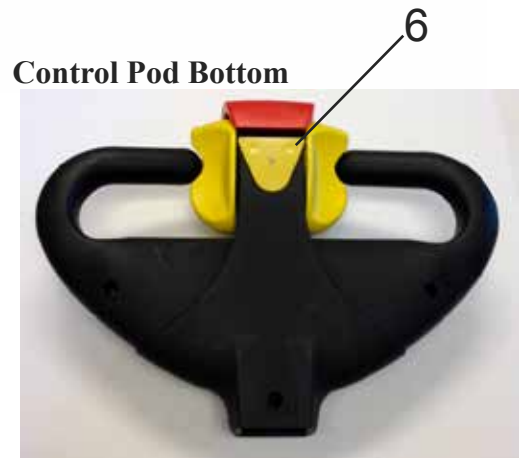
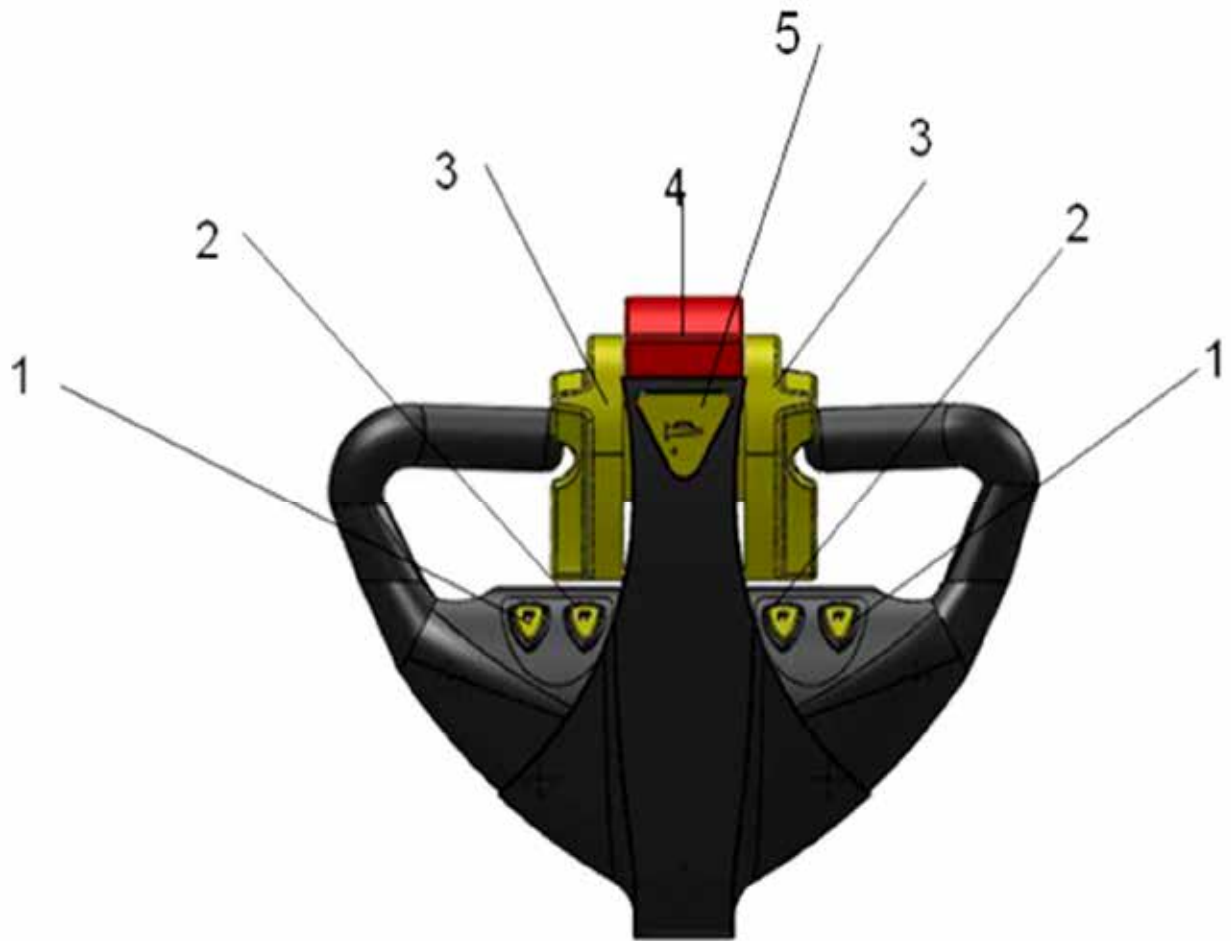

Item	Description	Qty
1	Lifting Switch	2
2	Lowering Switch	2
3	Butterfly Switch	1
4	Belly Button Stop Switch	1
5	Horn Button	1
6	Turtle Speed Switch	1

Figure 4: Steering Component

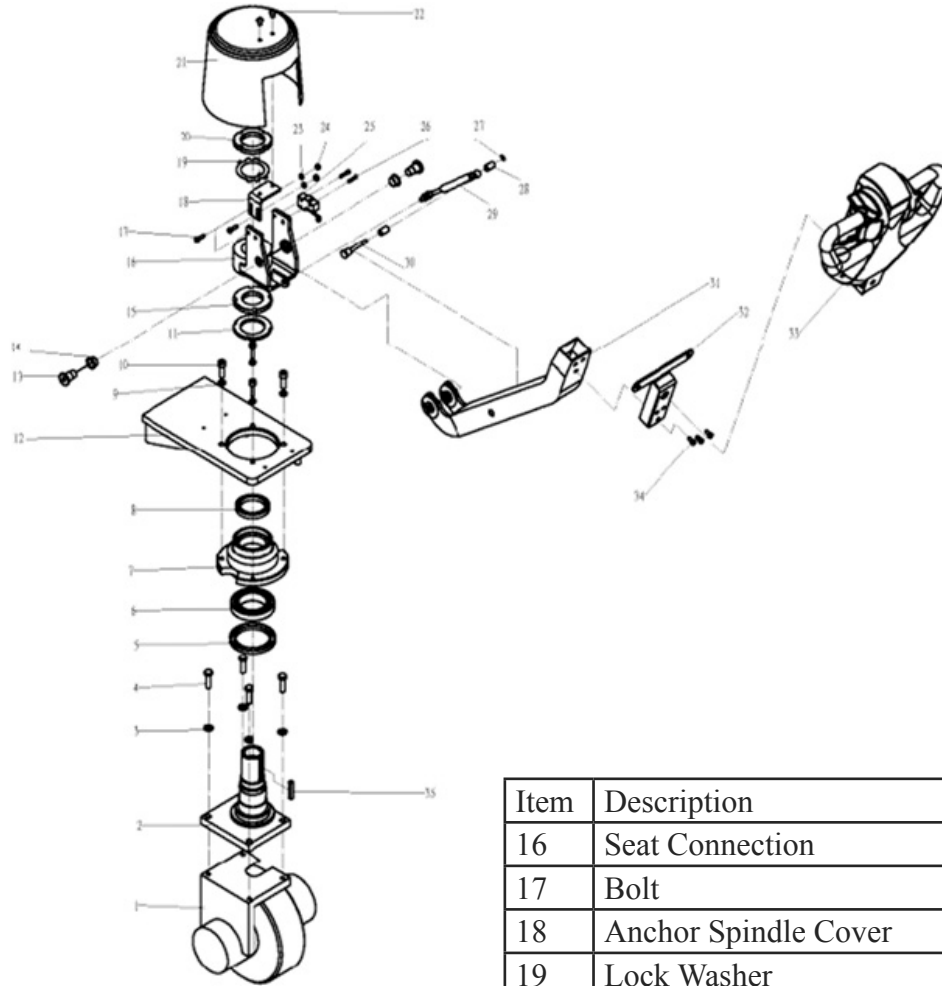

Item	Description	Qty
1	Drive wheel Assy	1
2	Spindle Assy	1
3	Spring Washer	4
4	Bolt	4
5	Seal	1
6	Bearing	1
7	Spindle Seat	1
8	Bearing	1
9	Bolt	4
10	Spring Washer	4
11	Washer	1
12	Fixing Board	1
13	Bolt	2
14	Collar Spindle	2
15	Lock Nut	1

Item	Description	Qty
16	Seat Connection	1
17	Bolt	2
18	Anchor Spindle Cover	1
19	Lock Washer	1
20	Nut	1
21	Spindle Cover	1
22	Screw	2
23	Spring Washer	2
24	Nut	2
25	Micro Switch	1
26	Bolt	2
27	Snap Ring	1
28	Spindle Collar	2
29	Air Spring	1
30	Fixing Shaft	1
31	Control Handle	1
32	Anchor Handle	1
33	Control Pod	1
34	Bolt	3
35	Flat Key	1

Figure 5: Drive Unit

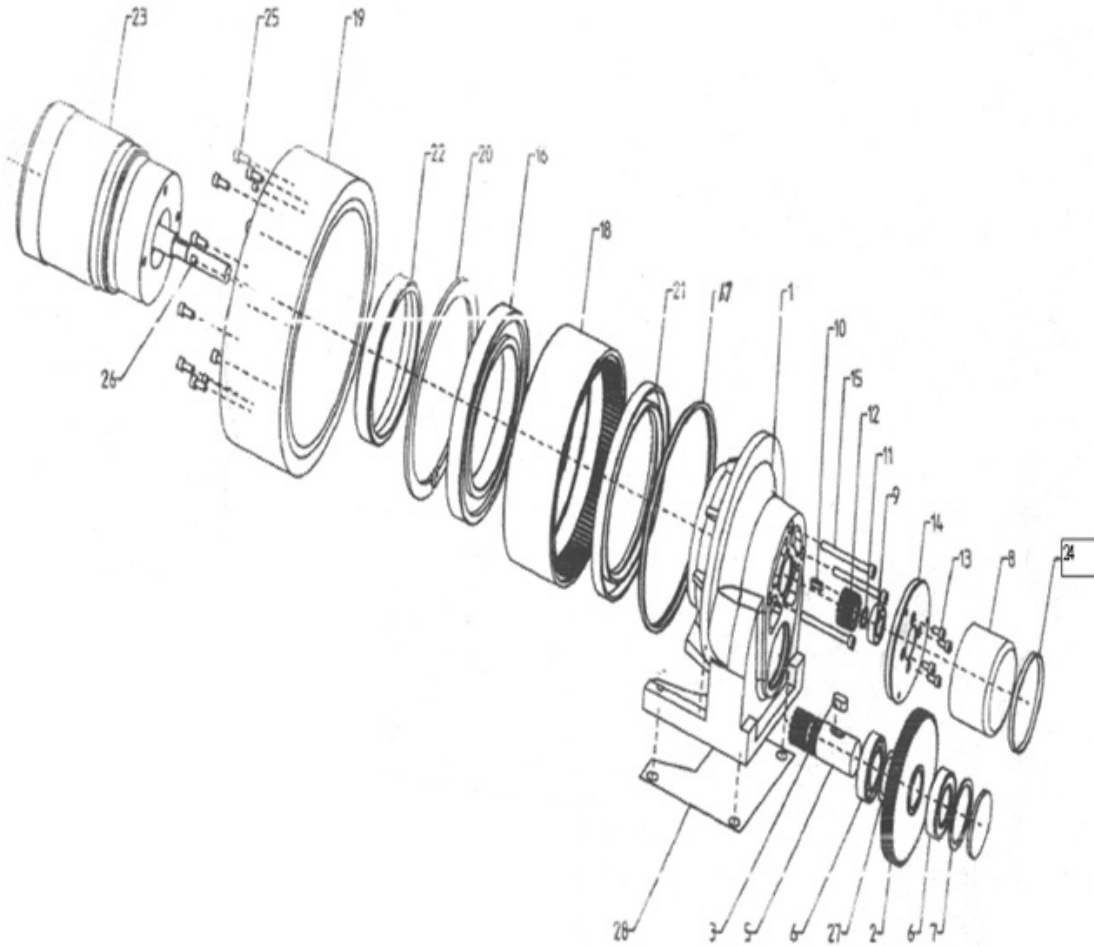

Item	Description	Qty
1	Casing	1
2	Gear	1
3	Key	1
4	Dust Cover	1
5	Shaft Gear	1
6	Bearing	2
7	C Clip	1
8	Electric Brake	1
9	Bearing	1
10	Key	2
11	C Clip	1
12	Gear	1
13	Screw	4
14	Flange	1

Item	Description	Qty
15	Screw	3
16	Bearing	1
17	Seal	1
18	Ring Gear	1
19	Wheel	1
20	C Clip	1
21	Seal	1
22	Ring	1
23	Traction Motor	1
24	Dust Ring	1
25	Screw	10
26	Screw	3
27	Spacer	1
28	Panel	1

Figure 6: Carriage Assembly

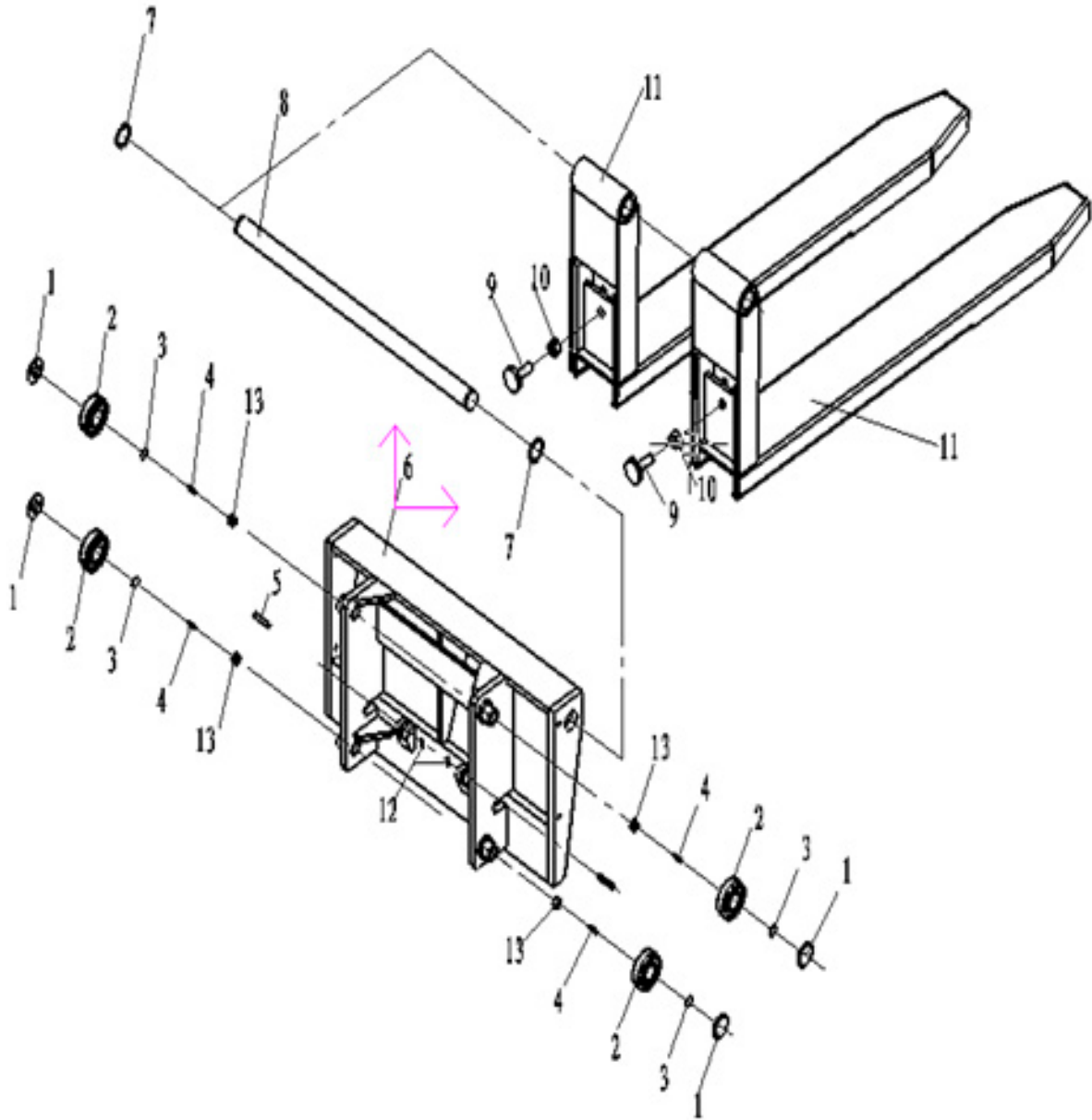

Item	Description	Qty
1	Block	4
2	Roller	4
3	Washer	4
4	Bolt	4
5	Fixed Pin, Chain	1
6	Load Bracket Assembly	1
7	Snap Ring	2
8	Feed Shaft	1
9	Bolt	2
10	Nut	2
11	Fork Assembly	2
12	Cotter Pin	2
13	Nut	4

Figure 7: Mast Components

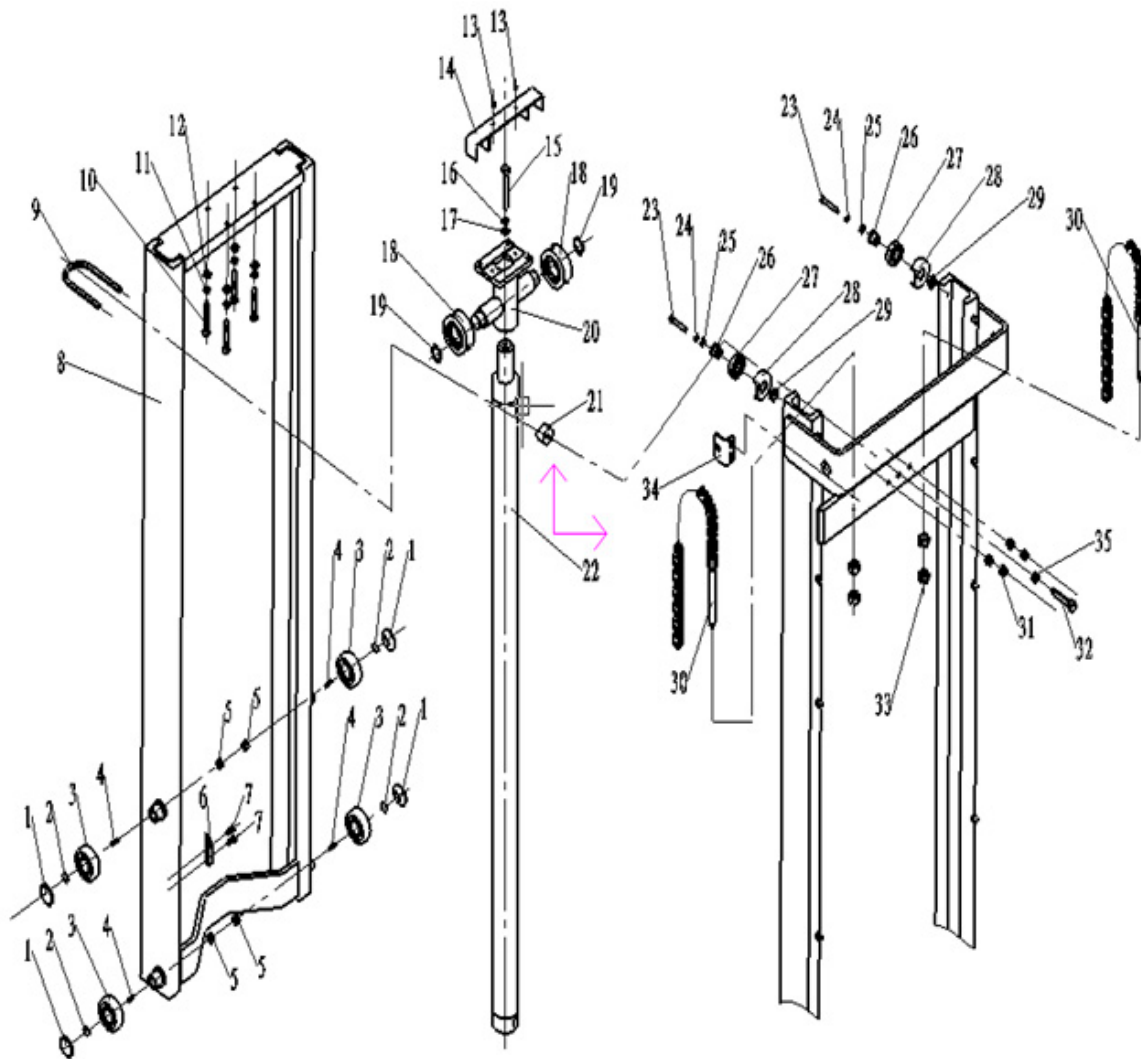

Item	Description	Qty
1	Block	4
2	Washer	4
3	Bearing	4
4	Bolt	4
5	Nut	4
6	Orientation Piece	1
7	Bolt	2
8	Mast Sub-Assy-Inner	1
9	U Bolt	1
10	Bolt	4
11	Spring Washer	4
12	Washer	4

Item	Description	Qty
13	Spring Pin	2
14	Chain Wheel Cover	1
15	Bolt	1
16	Spring Washer	1
17	Washer	1
18	Chain Wheel	2
19	Snap Ring	2
20	Chain Wheel Seat	1
21	Rubber Spacer	1
22	Lift Cylinder	1
23	Bolt	2
24	Spring Washer	2

Item	Description	Qty
25	Washer	2
26	Plug	2
27	Bearing	2
28	Dust Cover	2
29	Spacer	2
30	Chain Assembly	1
31	Nut	4
32	Bolt	1
33	Nut	4
34	Orientation Piece	1
35	Nut	1

Figure 8: Power Unit

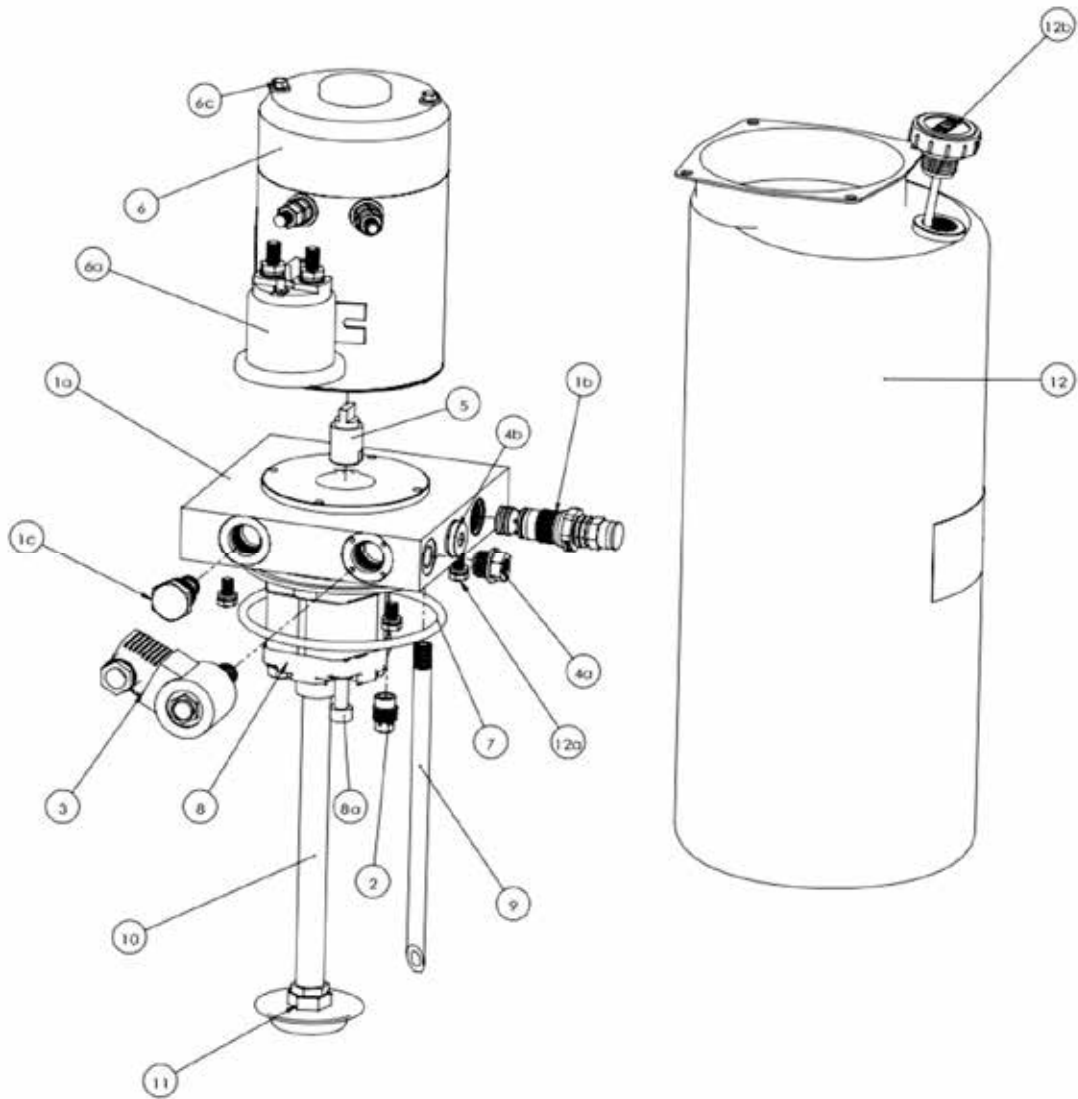

Item	Description	Qty
1A	Valve Block	1
1B	Relief Valve	1
1C	Unilateral Valve	1
2	Throttle Valve	1
3	Solenoid Valve	1
4A	Screw Plug, Metal	1
4B	Screw Plug, Plastic	1
5	Coupling	1
6	Motor	1
6A	Start Switch	1

Item	Description	Qty
6C	Bolt, Spring Washer	2
7	O-Ring	1
8	Gear Pump	1
8A	Bolt, Spring Washer	4
9	Oil Hose, Return	1
10	Oil Hose, Suction	1
11	Oil Filter	1
12	Oil Tank, Plastic	1
12A	Bolt, Spring Washer	4
12B	Cover, Oil Tank	1

Figure 9: Hydraulic System

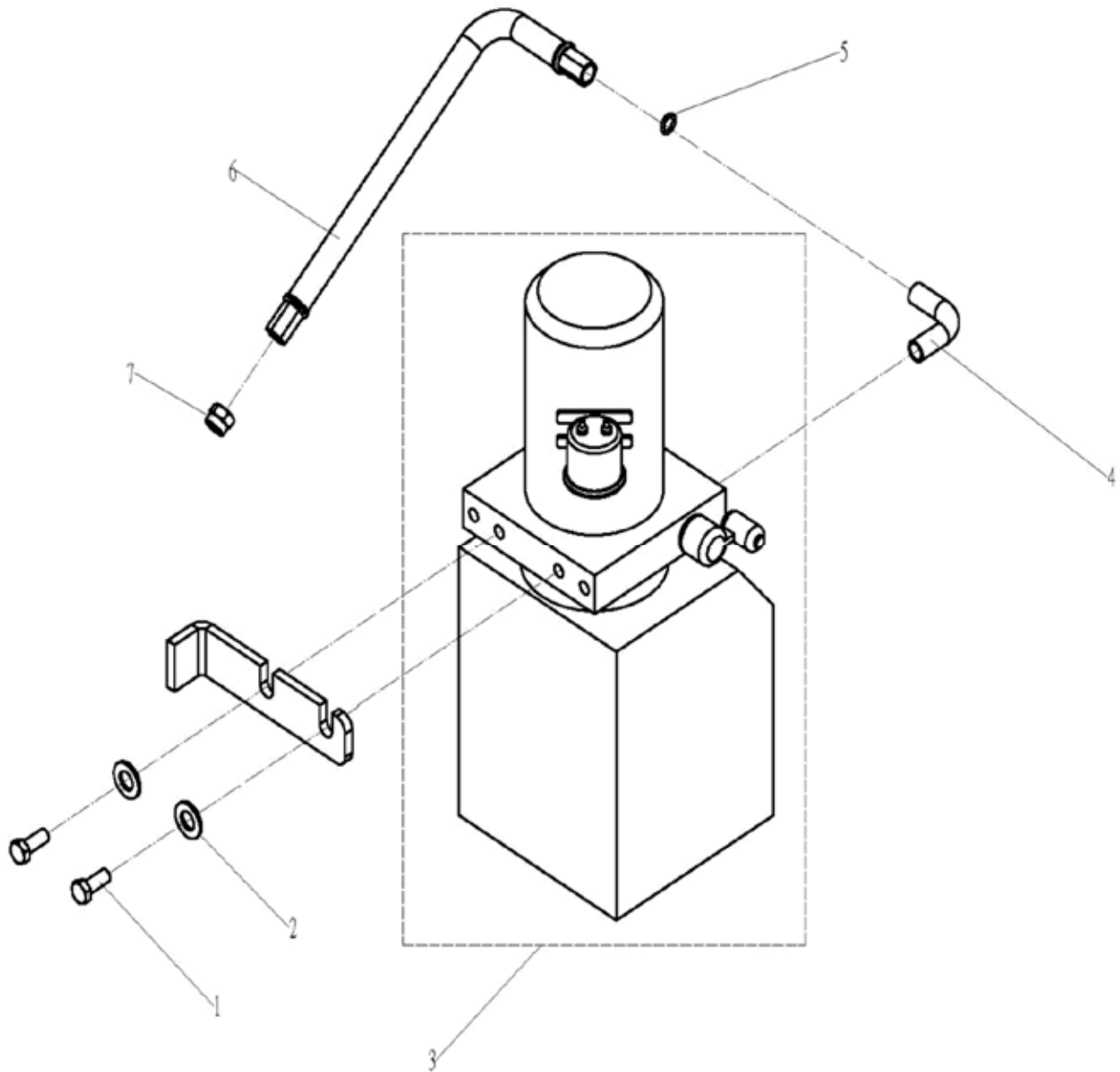

Item	Description	Qty
1	Screw	2
2	Washer	2
3	Hydraulic Assembly	1
4	L-Adaptor	1
5	O-ring	1
6	Oil Hose	1
7	Adaptor	1

Figure 10: Hydraulic Schematic

Schematic Diagram of Hydraulic System

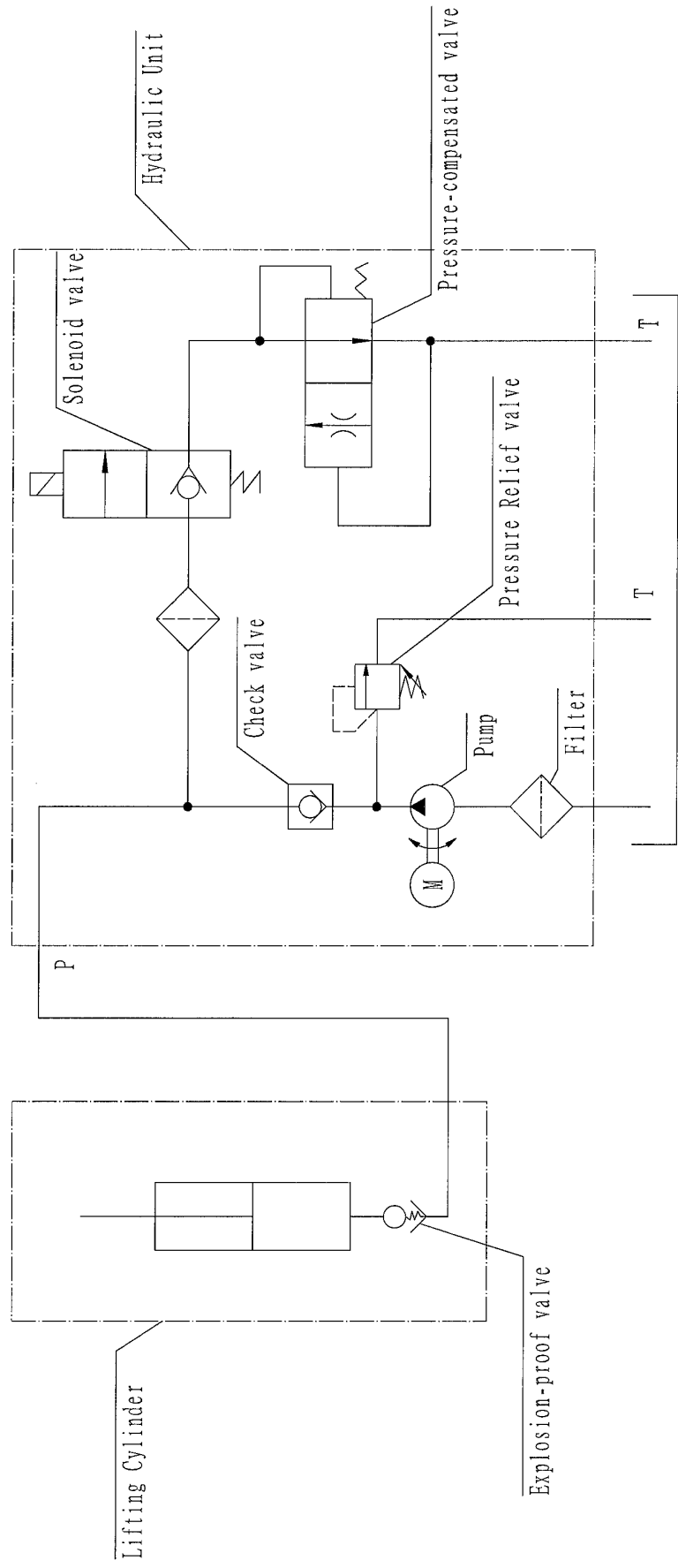
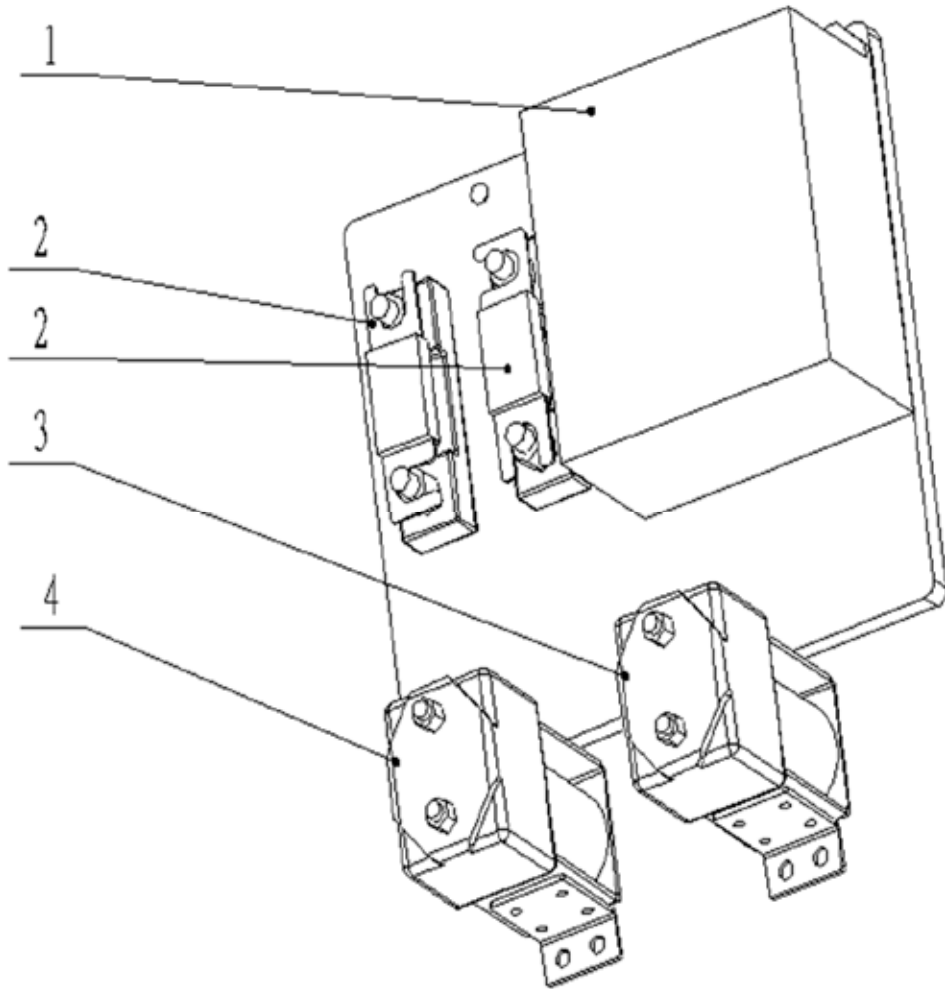

Figure 11: Control Panel



Item	Description	Qty
1	Controller	1
2	Fuse	1
3	Fuse	1
4	Travel Contactor	1
5	Lifting Contactor	1

Figure 12a: Electric Schematic Diagram - 24 Volt System
 (Two 12 Volt Batteries Connected in Series)

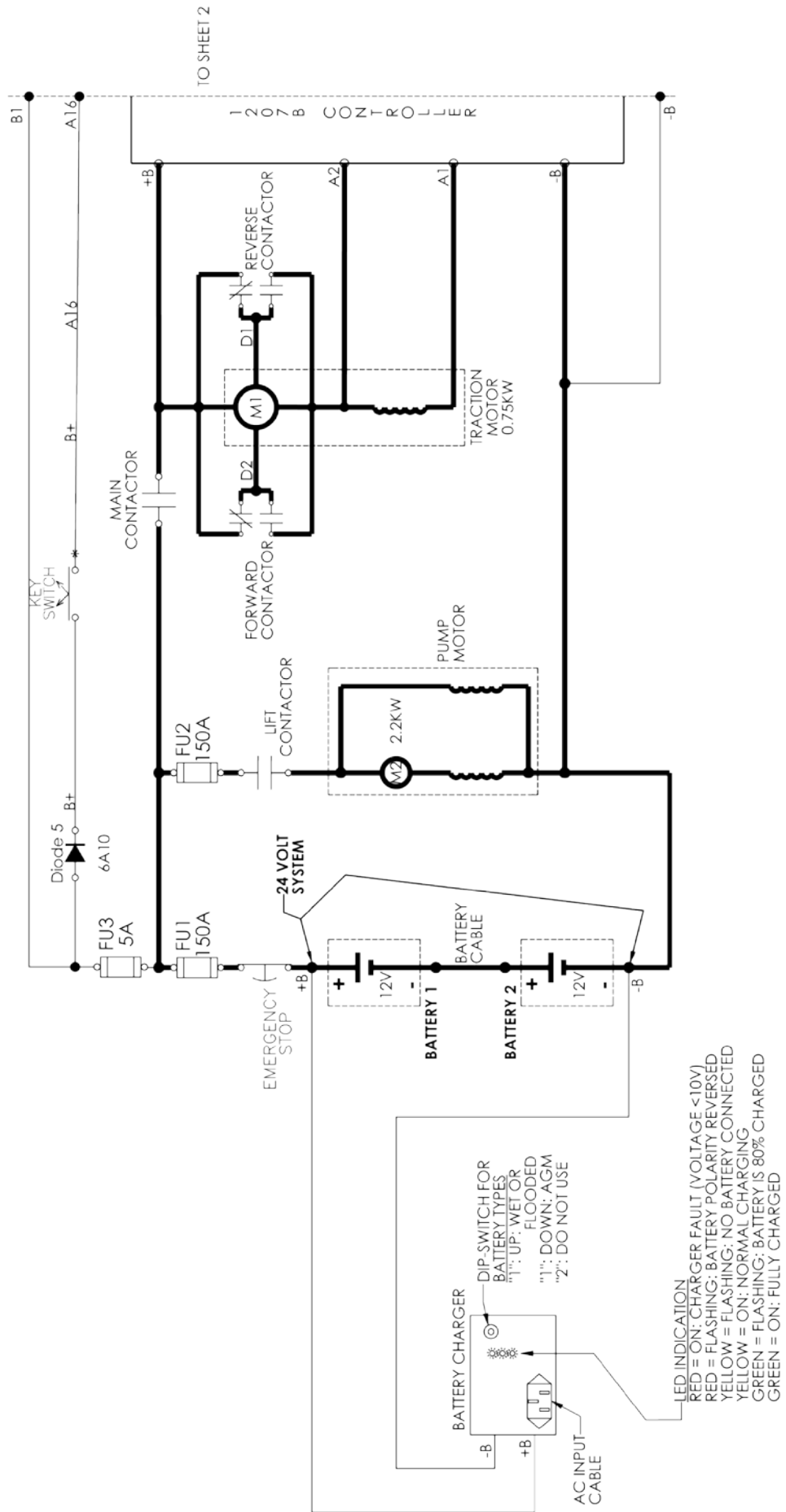

Figure 12b: Electric Schematic Diagram - 24 Volt System
 (Two 12 Volt Batteries Connected in Series)

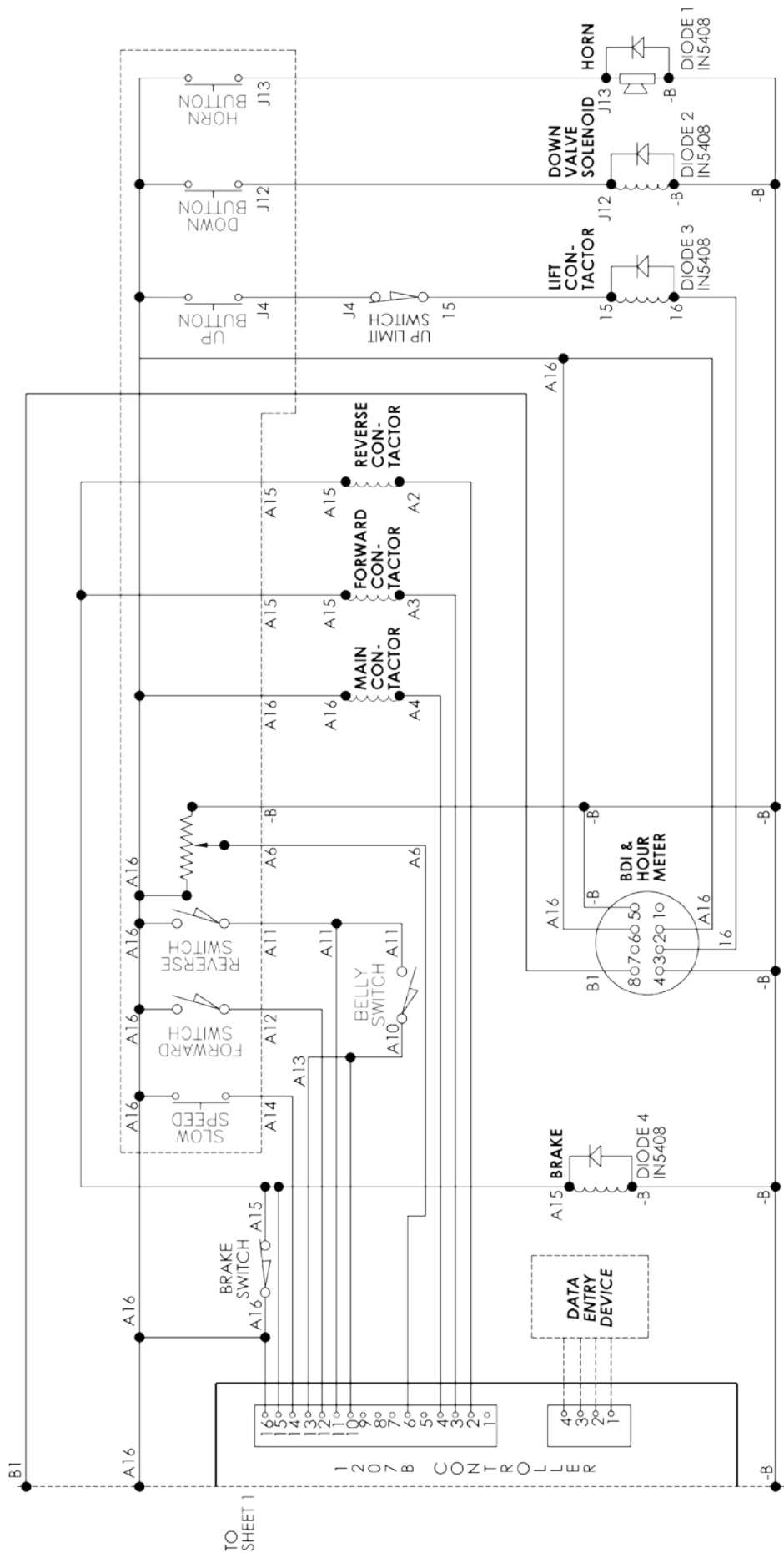

Figure 13: Battery Connection

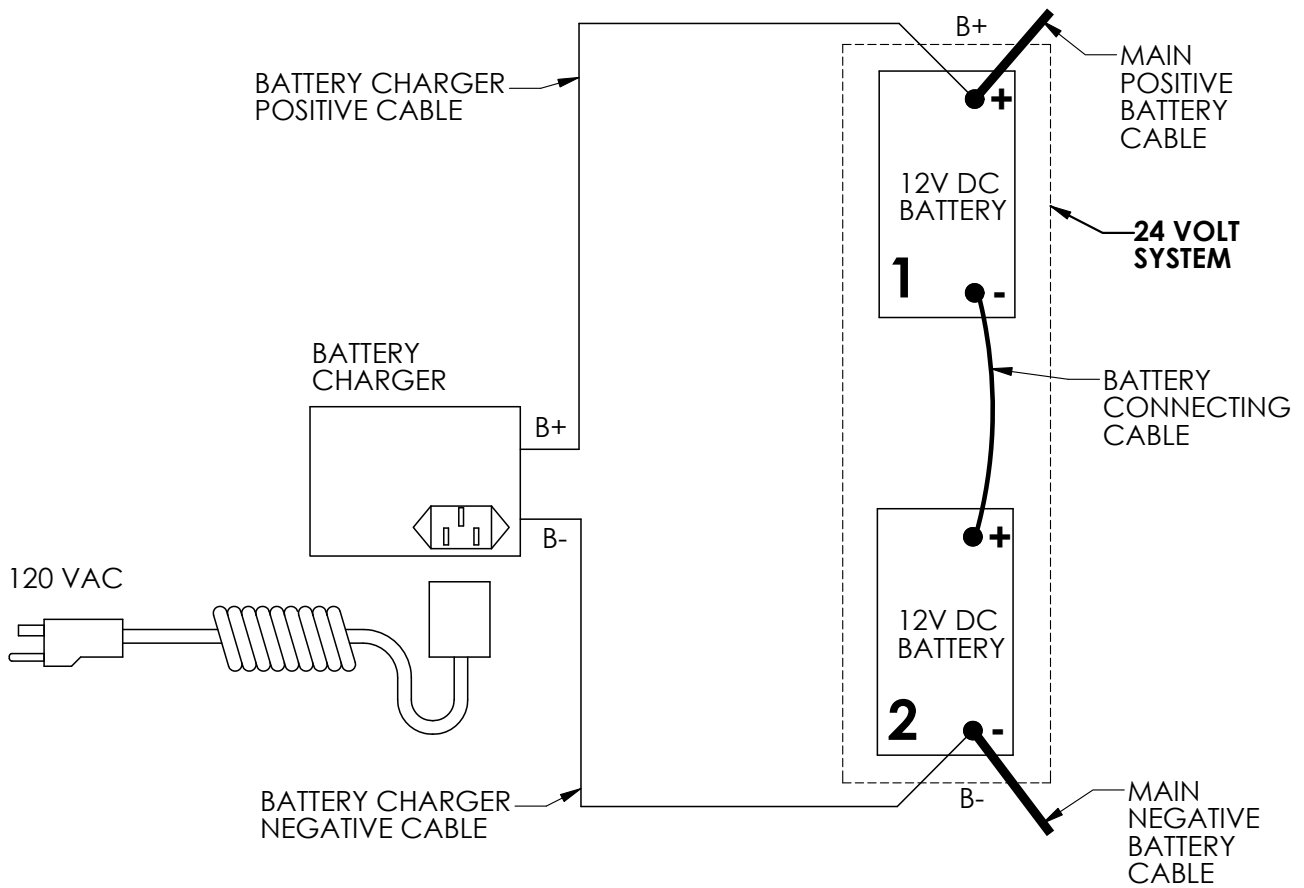

Figure 14: Label Placement



WARNING
NO RIDERS
DO NOT STAND UNDER FORKS
DO NOT LIFT PEOPLE
STAY CLEAR OF MOVING PARTS

ITEM # 3*

CAPACITY
2200 LBS
AT 24"
LOAD CENTER

ITEM # 7

*LOCATE (1) ON EACH
SIDE OF WIDE MAST

*LOCATE (1) ON EACH
SIDE OF WIDE MAST

PowerStak

ITEM # 2*

*PLACE DECAL HORIZONTAL
ON CROSS MEMBER

5

6*

WARNING
Always read the instructions and warnings before operating this equipment. Read the instructions before using the equipment. This equipment is not to be used for any purpose other than that intended. If you do not read and understand the instructions and warnings, you may be injured or killed. For more information, see the operator's manual.
NO RIDERS
Do not allow anyone to ride on the lift.
DO NOT LIFT PEOPLE
Do not lift people on the lift.
DO NOT STAND UNDER FORKS
Do not stand under the forks of the lift.
STAY CLEAR OF MOVING PARTS
Stay clear of moving parts of the lift.

ITEM # 1

*PLACE UPSIDE DOWN
ON INSIDE OF HANDLE

4

Presto LIFTS

ITEM # 4

WARNING
LIFTING CAPACITY ABOVE 7' IS LIMITED
Maximum Lifting Capacity
UP TO 7' 2,200 LBS. 1,000 LBD
UP TO 8' 1,000 LBS. 1,000 LBS.
UP TO 10' 1,000 LBS. 1,000 LBS.
Not applicable for 24" Load Center
See Operator's Manual for details.

ITEM # 8*

LIFT MANUFACTURED TO
ANSI B56.1-2004 PART 111
TRUCK WEIGHT/45%
WITHOUT BATTERIES
BATTERIES WEIGHT
VOLTAGE BATT. TYPE
W.G. DATE

ITEM # 5

Presto
LIFTS
800-343-9322 www.presto11fts.com
MODEL NO. _____ LBS. _____ L.C.
SERIAL NO. _____

ITEM # 6*

*LOCATE (1) ITEM #6 ON MACHINE
FRAME UNDER COVER

FRACTIONS 1/8 3/16 1/4 3/8 1/2 5/8 3/4 7/8
XX ANGLES 15° 30° 45° 60° 75° 90°
UNLESS OTHERWISE SPECIFIED
DIMENSIONS ARE IN INCHES
DECIMALS TO 0.001 INCHES
TOLERANCES UNLESS OTHERWISE SPECIFIED
ARE AS FOLLOWS:
DIMENSIONS ARE IN INCHES

ITEM NO.	QTY.	U/P/N	DESCRIPTION	PART NO.
8	EA	BK-4D LBL	3.00X7.00 DANGER	10055256
7	1	EA	LD DCL 2.00X3.25 CAPACITY 2200 LBS AT 24	10046160
6	2	EA	BK-4D TAG 3.50X1.87 NAME PLATE STACKER	C145L
5	1	EA	LD TAG LIFT MANUFACTURED TO ANSI/ITSDF B	10040297
4	1	EA	BK-4D DCL 12.00X3.00 PRESTO ALPHA	C155N
3	2	EA	BK-4D DCL 3.00X3.00 NO RIDERS	10039878
2	1	EA	BK-4D DCL 3.00X2.00 POWER STAK	10039877
1	1	EA	BK-4D DCL 2.25X8.50 1 WARNING USERS MUST	10039876

THIS DRAWING MUST BE A REVISION: A

ORDERING REPLACEMENT PARTS

Presto Lifts has carefully chosen the components in your unit to be the best available for the purpose. Replacement parts should be identical to the original equipment. Presto Lifts will not be responsible for equipment failures resulting from the use of incorrect replacement parts or from unauthorized modifications to the unit.

Presto Lifts can supply all replacement parts for your lift. With your order, please include the model number and the serial number of the unit. You can find these numbers on the name plate. This plate is located within the cabinet, or the angle iron cylinder cross support.

To order replacement parts, please call the Presto Parts Department. Parts are shipped subject to the following terms:

- FOB factory
- Returns only with the approval of our Parts Department.
- Credit cards preferred (except parts covered by warranty).
- Freight collect for truck (except parts covered by warranty).
- Freight - prepaid and invoice for small parcel shipments (except parts covered by warranty).
- The warranty for repair parts is 30 days from date of shipment.

Parts replaced under warranty are on a “charge-credit” basis. We will invoice you when we ship the replacement part, then credit you when you return the worn or damaged part, and we verify that it is covered by our warranty. Labor is not covered under warranty for Parts orders.

Presto Lifts Parts Department
50 Commerce Way, Norton, MA 02766
Telephone: 800-343-9322
FAX: 888-788-6496
Email: Service@PrestoLifts.com
www.PrestoLifts.com

RESTOCKING POLICY

PARTS

Standard parts may be returned with a 20% restocking fee. Modified or custom-engineered parts are not returnable. Unfortunately, due to potentially concealed damage, all sales of electrical assemblies are final.

QUALITY ISSUES

Should you feel there is a quality problem, please contact the seller to ask questions and gather information on how to rectify the issue. Presto Lift Inc. reserves the right to determine potential credits, as a result of factory defects, based on its inspection of the merchandise.

GENERAL

All products shipped from our factory have passed Quality Assurance inspection and testing. The carrier of choice has signed for, and accepted the product in new working condition. The customer should inspect to ensure it is not received damaged, has no concealed damage or is not incomplete. Parts orders are determined to be complete based upon Presto Lift, Inc. inspection sheets and carrier shipping weights.