

R&S[®] RT-ZD40

Active Differential Probe

User Manual



1410536302

This User Manual describes the following R&S®RT-ZD models and options:

- R&S®RT-ZD40 (1410.5205.02)

© 2019 Rohde & Schwarz GmbH & Co. KG

Mühlhofstr. 15, 81671 München, Germany

Phone: +49 89 41 29 - 0

Fax: +49 89 41 29 12 164

Email: info@rohde-schwarz.com

Internet: www.rohde-schwarz.com

Subject to change – Data without tolerance limits is not binding.

R&S® is a registered trademark of Rohde & Schwarz GmbH & Co. KG.

Trade names are trademarks of the owners.

1410.5363.02 | Version 05 | R&S®RT-ZD40

Throughout this manual, products from Rohde & Schwarz are indicated without the ® symbol and without product type numbers, e.g. R&S®RT-ZD40 is indicated as R&S RT-ZD40.

Contents

1 Product Description.....	5
1.1 Key Features and Key Characteristics.....	5
1.1.1 Key Characteristics.....	5
1.1.2 Key Features.....	6
1.2 Unpacking.....	7
1.2.1 Inspecting the Contents.....	7
1.3 Description of the Probe.....	8
1.3.1 Probe Head.....	8
1.3.2 Probe Box.....	9
1.4 Accessories and Items.....	10
1.4.1 Accessories Supplied.....	11
1.4.2 Optional Accessories.....	12
1.4.3 Service Accessories.....	13
2 Putting into Operation.....	14
2.1 Connecting the Probe to the Oscilloscope.....	15
2.2 Identification of the Probe.....	16
2.3 Using the Probe.....	16
2.3.1 Zero Adjustment.....	16
2.3.2 Micro Button.....	17
2.4 Offset Compensation.....	17
2.4.1 Differential Offset.....	17
2.4.2 Common Mode Offset.....	18
2.4.3 R&S ProbeMeter.....	20
3 Connecting the Probe to the DUT.....	22

4 Characteristics of Differential Probes.....	27
4.1 Common Mode Rejection Ratio (CMRR).....	28
4.2 Dynamic Range and Operating Voltage Window.....	29
4.3 Ground Connection.....	30
5 Measurement Principles.....	31
5.1 Signal Integrity of the Transferred Signal.....	33
5.1.1 Bandwidth.....	33
5.1.2 Connection Inductance.....	34
5.1.3 CMRR.....	37
5.2 Signal Loading of the Input Signal.....	37
5.2.1 Signal Loading for Differential Input Signals.....	38
5.2.2 Signal Loading for Non-Differential Input Signals.....	40
5.3 Probing Philosophy.....	40
6 Maintenance and Service.....	42
6.1 Cleaning.....	42
6.2 Contacting Customer Support.....	42
6.3 Returning for Servicing.....	43
6.4 Calibration Interval.....	44
6.5 Discarding the Product.....	44
6.6 Spare Parts.....	44
7 Functional Check.....	47
Index.....	48

1 Product Description

1.1 Key Features and Key Characteristics

The R&S RT-ZD40 is a differential probe with high input impedance. It is used for differential voltage measurements from DC to 4.5 GHz.

Differential probes can be used for single-ended and differential applications. They are equipped with two high-impedance inputs and can measure the voltage between any two test points. Unlike using single-ended probes, there is no need to ensure that one of the test points is always at ground potential.

The comprehensive accessory set allows this probe to be connected to a wide variety of devices under test (DUT). Provided with special features such as the R&S ProbeMeter and the micro button, the R&S RT-ZD40 is designed to meet tomorrow's challenges in probing.

The probe is equipped with the Rohde & Schwarz probe interface. It can be connected to any Rohde & Schwarz instrument that is compatible with this interface. When connected to the front panel, the probe is controlled by the oscilloscope's software. Supported oscilloscopes are listed in the data sheet.

Using a specially developed adapter (see [Chapter 1.4.2, "Optional Accessories"](#), on page 12), the probe can also be connected to any other base unit.

1.1.1 Key Characteristics

The key characteristics of the probe are the following:

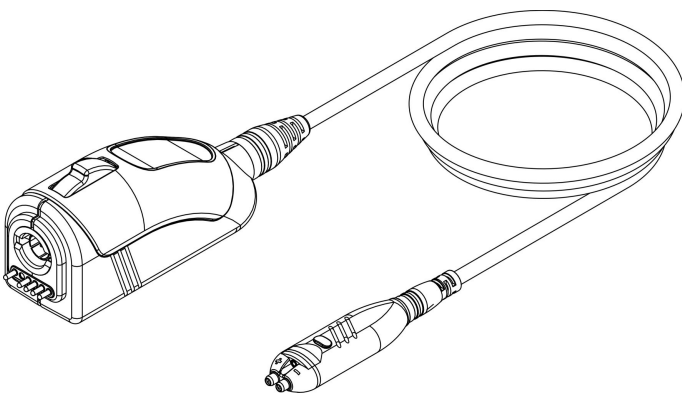

Key Features and Key Characteristics

Bandwidth	DC to 4.5 GHz
Dynamic range (differential input)	± 5 V with ± 5 V offset capability 10 V AC (Vpp)
Operating voltage window (each pin to GND)	± 8 V with ± 22 V common mode offset capability Available for R&S RT-ZD40 probes with serial number ≥ 200000
Maximum non-destructive input voltage	± 30 V Between each signal pin and ground
Diff. input resistance	1 M Ω
Diff. input capacitance	0.4 pF
R&S ProbeMeter, measurement error	<0.1 %
Extremely low zero and gain errors throughout the entire temperature range, no significant temperature drift	
Micro button	
Rohde & Schwarz probe interface	

1.1.2 Key Features

Micro button

The micro button at the probe head can remotely control different functions on the base unit. The assigned function is configured via the base unit.

For details, see [Chapter 2.3.2, "Micro Button"](#), on page 17.

R&S ProbeMeter

The R&S ProbeMeter measures the DC voltage of the input signal directly at the probe tip. It provides a continuous high-precision DC voltage measurement that is independent of the settings of the oscilloscope and runs in parallel to the time domain measurement. If activated on the base unit, the measured value is displayed on the screen of the Rohde & Schwarz oscilloscope.

The R&S ProbeMeter simultaneously measures both differential and common mode DC voltages.

For details, see [Chapter 2.4.3, "R&S ProbeMeter"](#), on page 20.

Data memory

The probe has an integrated data memory, containing the individual probe correction parameters (e.g. gain, delay, offset). These parameters are read out and processed by the Rohde & Schwarz oscilloscope. As a result, the probe offers a high degree of accuracy, and additional calibration procedures are not required.

1.2 Unpacking

The carrying case contains the following items:

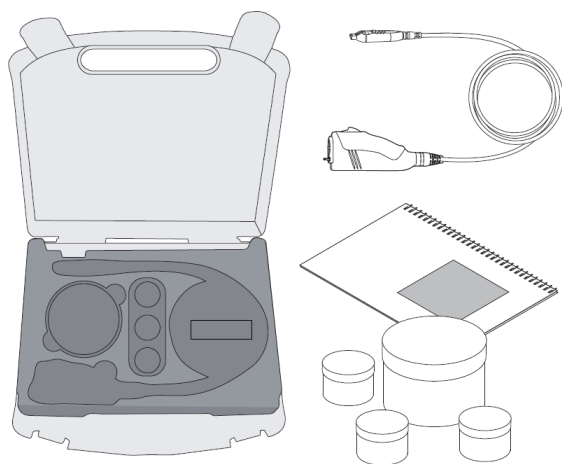

- R&S RT-ZD40 differential probe
- Carrying case
- Accessory boxes
- User manual
- R&S RT-ZD40 data sheet
- Calibration certificate
- Documentation of calibration values (if ordered)

1.2.1 Inspecting the Contents

- Inspect the package for damage.
Keep the package and the cushioning material until the contents have been checked for completeness and the device has been tested.
If the packaging material shows any signs of stress, notify the carrier and your Rohde & Schwarz service center. Keep the package and cushioning material for inspection.
- Inspect the probe.
If there is any damage or defect, or if the R&S RT-ZD40 differential probe does not operate properly, notify your Rohde & Schwarz service center.
- Inspect the accessories.
If the contents are incomplete or damaged, notify your Rohde & Schwarz service center.

Accessories supplied with the device are listed in [Chapter 1.4.1, "Accessories Supplied"](#), on page 11.

1.3 Description of the Probe

The probe consists of the probe head for connection to the DUT, the probe box for connection to the oscilloscope, and the probe cable.

1.3.1 Probe Head

The small and lightweight probe head is designed for easy handling and high-performance measurements. The probe head is used for connecting the probe and the DUT. Different accessories for the signal and ground sockets allow the probe head to be connected to a wide range of DUTs.

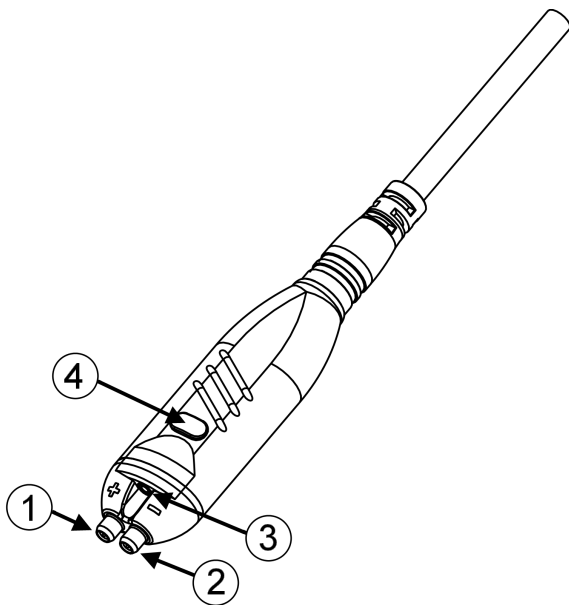

- (1) Positive signal socket
- (2) Negative signal socket
- (3) Ground socket
- (4) Micro button

The accessories supplied for the probe head sockets are listed in [Chapter 1.4.1, "Accessories Supplied"](#), on page 11.

The ground socket is compatible with 0.64 mm (25 mil) square pins and 0.6 mm to 0.8 mm (24 mil to 35 mil) round pins.

Spacing of signal sockets: 4 mm (160 mil).

NOTICE**Special accessories for signal sockets**

The signal sockets of R&S RT-ZD40 have a special design to ensure optimal performance. The signal sockets are *not* compatible to standard accessories based on 0.64 mm (25 mil) square pins or 0.8 mm (35 mil) round pins. Use only special accessories for R&S RT-ZD40 provided by Rohde & Schwarz.

1.3.2 Probe Box

The probe box connects the probe and the oscilloscope via the Rohde & Schwarz probe interface. The Rohde & Schwarz probe interface contains a male precision 7 mm (276 mil) BNC connector and six pogo pin connectors. This interface provides the required supply voltage and is also used to transmit analog signals and digital data simultaneously. All the analog voltages required by the probe are generated in the probe box. This approach ensures that it will be possible to operate future probes on any base unit that features a Rohde & Schwarz probe interface.

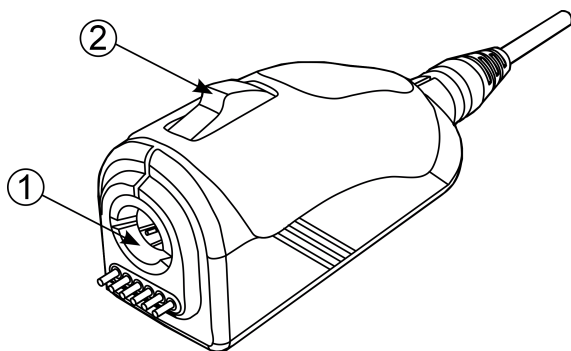

- (1) Rohde & Schwarz probe interface with 7 mm (276 mil) coaxial connector and 6 pogo pins
- (2) Release knob

Connect the R&S RT-ZD40 only to an instrument with Rohde & Schwarz probe interface. Never connect it to a usual BNC jack. Although the 7 mm coaxial connector looks like a standard BNC connector, it is constructed differently and does not fit to the standard BNC jack. The interface of the R&S RT-ZD40 can withstand a higher frequency limit.

1.4 Accessories and Items

The figure below shows all accessories that are available for the R&S RT-ZD40 differential probe.

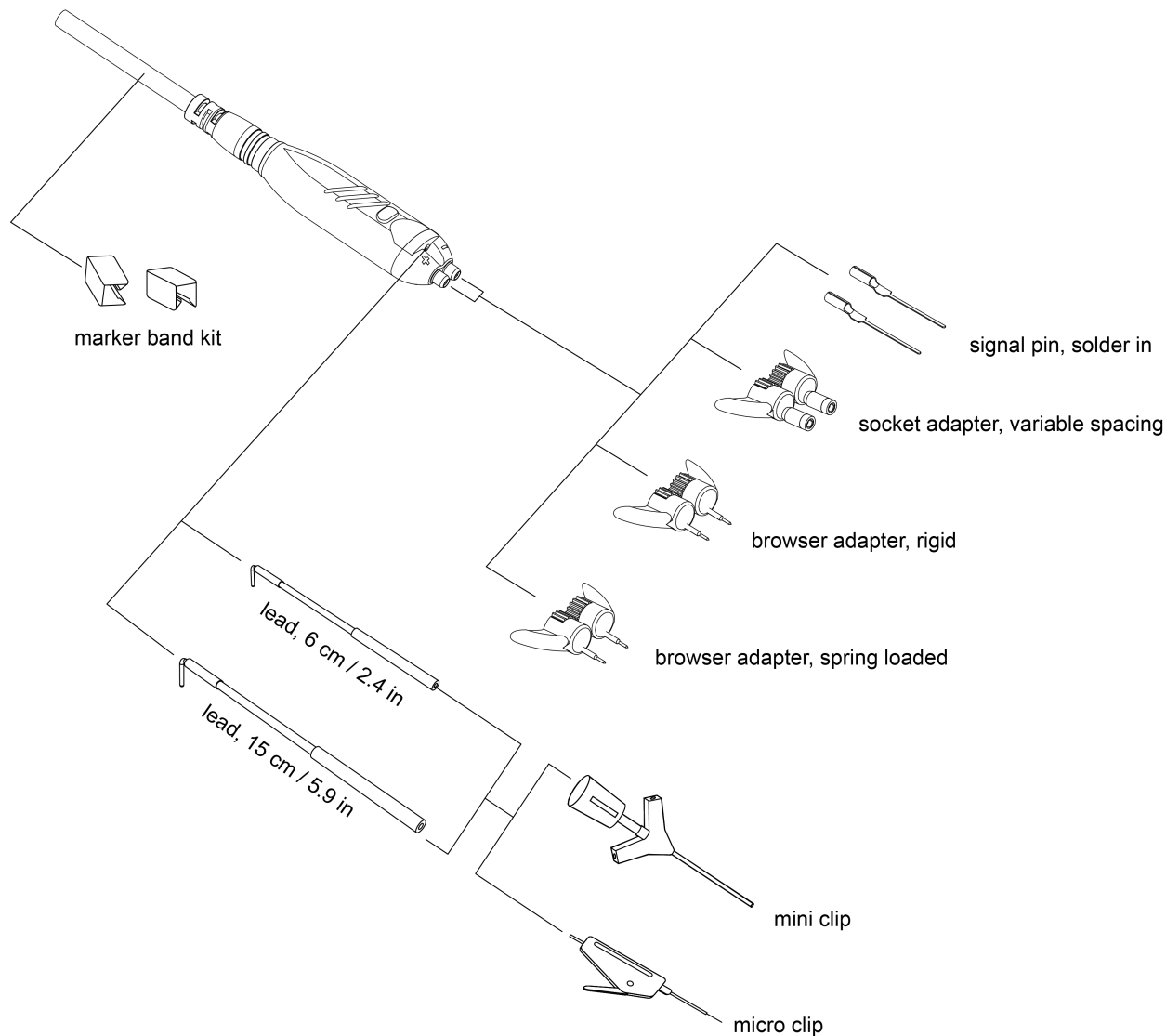

Figure 1-1: Available accessories

The R&S RT-ZA15 external attenuator is not a accessory of the R&S RT-ZD40. Putting the R&S RT-ZA15 on the R&S RT-ZD40 can damage both parts mechanically.

1.4.1 Accessories Supplied

The following table shows the accessories supplied with the R&S RT-ZD40 differential probe.

Table 1-1: Accessories supplied

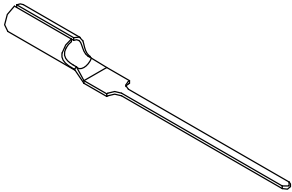
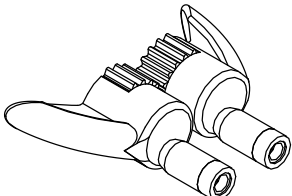
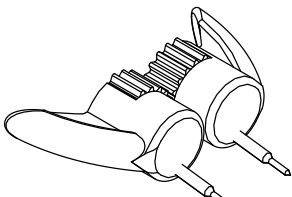
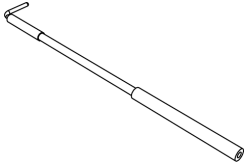
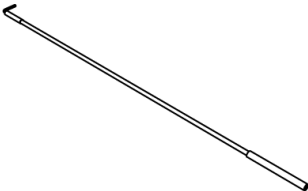
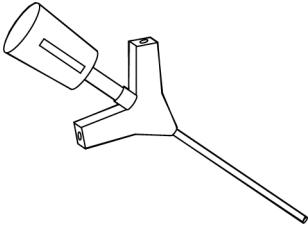
Item	Quantity	Description
	100	Signal pin, solder-in
	2	Socket adapter, variable spacing
	2	Browser adapter, rigid
	2	Browser adapter, spring-loaded
	2	Lead, 6 cm / 2.4 in
	1	Lead, 15 cm / 5.9 in
	2	Mini clip

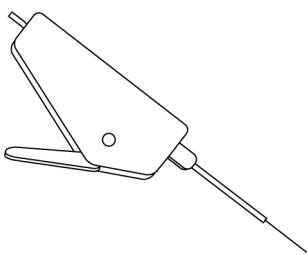
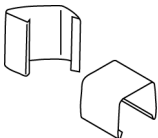
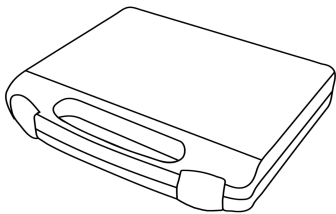
Item	Quantity	Description
	2	Micro clip
	1	Marker band kit
	1	Carrying case with foam inlay

For a list of spare parts, see [Chapter 6.6, "Spare Parts"](#), on page 44.

1.4.2 Optional Accessories

If the delivered accessories do not meet individual customer requirements, Rohde & Schwarz offers different accessory sets for sale. The order numbers are provided in the data sheet.

Table 1-2: R&S RT-ZA4 mini clips

Item	Quantity	Description
Mini clip	10	Contains mini clips.

Table 1-3: R&S RT-ZA5 micro clips

Item	Quantity	Description
Micro clip	4	Contains micro clips.

Table 1-4: R&S RT-ZA6 lead set

Item	Quantity	Description
Lead, 6 cm / 2.4 in	5	Contains short and long leads.
Lead, 15 cm / 5.9 in	5	

Table 1-5: R&S RT-ZA8 differential pin set

Item	Quantity	Description
Signal pin, solder-in	100	Contains the pins available for the R&S RT-ZD40.
Socket adapter, variable spacing	2	
Browser adapter, rigid	2	
Browser adapter, spring-loaded	2	

Table 1-6: R&S RT-ZA9 probe box to N / USB adapter

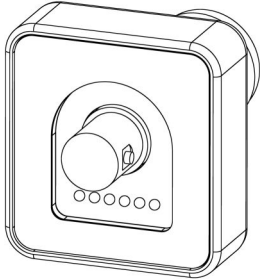
	<p>The adapter can be used to connect the R&S RT-ZD40 differential probe to any other oscilloscope or any other measurement instrument (e.g. a network or spectrum analyzer).</p> <p>Using the USB interface of the adapter, the probe can be powered and controlled from any conventional PC.</p>
------------------------------------------------------------------------------------	--------------------------------------------------------------------------------------------------------------------------------------------------------------------------------------------------------------------------------------------------------------------------------------------------------

1.4.3 Service Accessories

To order accessories for servicing the probe, contact your Rohde & Schwarz service center. The following accessories are available:

Table 1-7: Service accessories

Item	Description
R&S RT-ZK2	The service kit is used to calibrate the probe, to do performance tests, and for servicing. The service kit includes all adapters and accessories to connect the probe to the required measuring instruments.
R&S RT-ZD40 Service Manual	The service manual contains a detailed description of the performance test to verify the specifications, and other important service procedures.

2 Putting into Operation

The probe is designed for usage with oscilloscopes that have a Rohde & Schwarz probe interface. Supported Rohde & Schwarz oscilloscopes are listed in the probe's data sheet.

Read and observe the printed "Basic Safety Instructions" that are delivered with the probe. Also, read and observe the safety instructions of the oscilloscope the probe is connected to.

NOTICE

Maximum non-destructive input voltage

The maximum non-destructive input voltage is ± 30 V. A higher input voltage can destroy the probe. The maximum non-destructive input voltage of a differential probe is specified as the maximum voltage between each signal pin and ground. The maximum input voltage is derated for higher frequencies. Refer to the data sheet for further information.

NOTICE

Risk of device damage

The R&S RT-ZD40 can withstand a moderate amount of physical and electrical stress. To avoid damage, treat the probe with care:

- Do not exceed the specified voltage limits.
 - Connect the R&S RT-ZD40 only to an instrument with Rohde & Schwarz probe interface. Never connect it to a usual BNC jack. Although the 7 mm coaxial connector looks like a standard BNC connector, it is constructed differently and does not fit to the standard BNC jack. The interface of the R&S RT-ZD40 can withstand a higher frequency limit.
 - Handle the probe by the probe head or probe box. Avoid excessive strain on the probe cable, and kinking.
 - Prevent the probe from receiving mechanical shock.
 - Do not spill liquids on the probe.
 - Store the probe in a shock-resistant case, e.g. in the shipping case.
-

Connecting the Probe to the Oscilloscope

During usage, the probe slightly heats up. Warming is normal behavior and not a sign of malfunction.

NOTICE**Damage caused by electrostatic discharge**

Electrostatic discharge (ESD) can damage the electronic components of the probe and the instrument, and also the device under test (DUT). Electrostatic discharge is most likely to occur when you connect or disconnect a DUT or test fixture to the probe and to the instrument's test ports. To prevent electrostatic discharge, use a wrist strap and cord and connect yourself to the ground, or use a conductive floor mat and heel strap combination. Discharge cables and probe tips before you connect them.

2.1 Connecting the Probe to the Oscilloscope

- ▶ Connect the probe box (1) to the Rohde & Schwarz probe interface of the oscilloscope (2).

The probe snaps in when connected properly to the port.

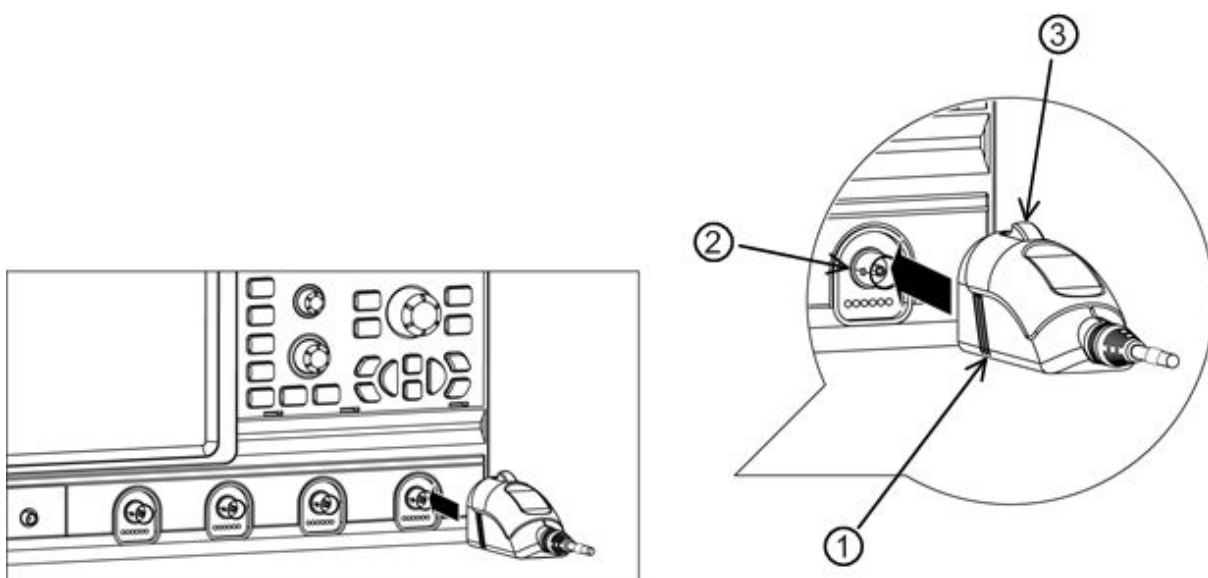

Figure 2-1: Connecting the probe to the Rohde & Schwarz oscilloscope

- ▶ To disconnect the probe:
 - a) Press and hold the release button (3).
 - b) Pull the probe box away from the oscilloscope.

2.2 Identification of the Probe

When the probe is connected to the oscilloscope, the oscilloscope recognizes the probe and reads out the probe-specific parameters.

The oscilloscope settings for attenuation and offset are automatically adjusted. After the probe is connected to the oscilloscope and the settings are adjusted, the waveform is shown for the channel to which the probe is connected.

The complete probe information is shown in the probe settings dialog. For more information, refer to the user manual of your oscilloscope.

2.3 Using the Probe

2.3.1 Zero Adjustment

The zero error can impair the measurement results, therefore, correct the zero error if necessary. The zero error of the probe itself is very small. However, differences in DUT and oscilloscope ground levels can cause larger zero errors visible on the oscilloscope's screen. If the DUT is not floating but ground-referenced, a zero adjustment improves the measurement results.

The zero error is corrected at the oscilloscope. Depending on the type of the used oscilloscope, correction is done automatically using the AutoZero function, or manually ("Zero Adjust" or similar setting). Refer to the oscilloscope's user manual for available functionality and its usage.

1. Connect the probe to the Rohde & Schwarz oscilloscope.
2. Set the oscilloscope to the smallest vertical scale.
3. Short the signal pins and the ground pin together.

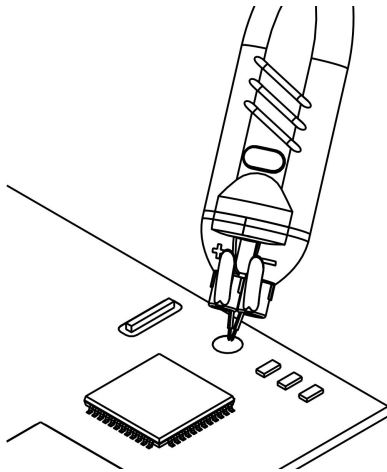

4. Adjust the zero position of the waveform using the appropriate function of the oscilloscope ("AutoZero", "Zero Adjust" or similar).

The waveform is set to 0 V on the horizontal centerline of the oscilloscope.

2.3.2 Micro Button

The micro button provides easy and quick access to important functions of the Rohde & Schwarz oscilloscope. After a function has been assigned, pressing the micro button remotely controls this specific function on the base unit. For example, "Run continuous" or "Run single" are often assigned to the micro button.

The configuration of the micro button is part of the probe settings of the channel to which the probe is connected. For more details, see the oscilloscope's user manual.

2.4 Offset Compensation

The R&S RT-ZD40 features two offset compensation functions: a differential offset compensation and a common mode offset compensation. Each function compensates a particular DC component of the input signal, even in front of the active amplifier in the probe tip. For a definition of differential and common mode input voltages, see [Chapter 4, "Characteristics of Differential Probes"](#), on page 27.

2.4.1 Differential Offset

The differential offset compensation is often referred to as *offset compensation*.

The differential offset function can compensate a DC voltage applied between the positive and the negative input socket. This is particularly helpful if a small single-ended signal with a large DC offset is measured with a differential probe, for example, with the negative input socket connected to ground. As the R&S RT-ZD40 measures differential voltages, setting a differential offset compensation is directly visible on the oscilloscope screen as a voltage offset of the measured waveform.

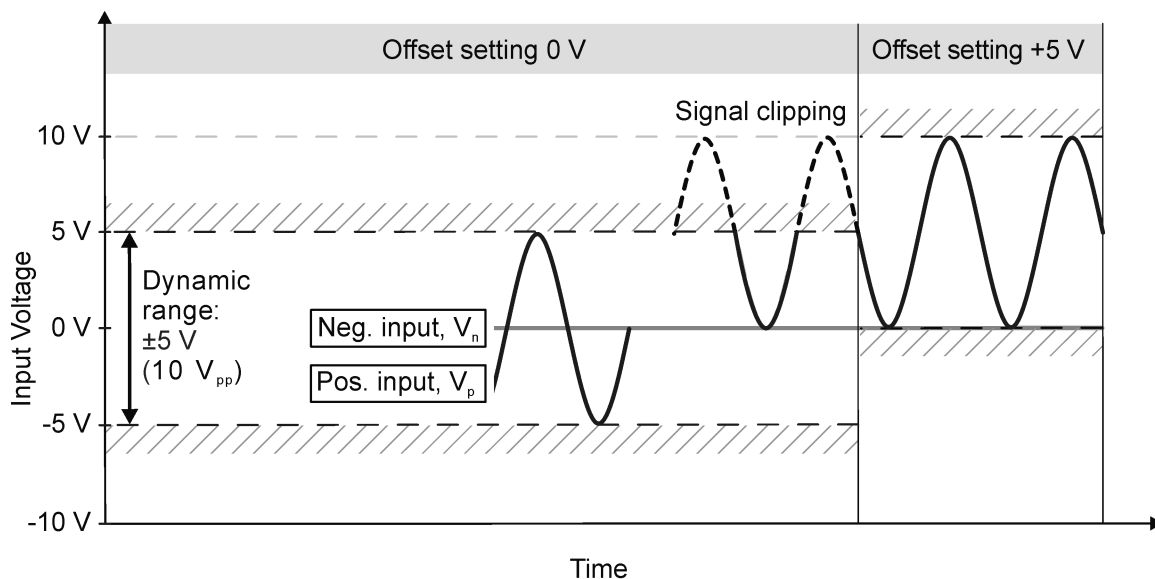

Figure 2-2: Differential offset compensation for a single-ended measurement (negative input connected to ground) using an R&S RT-ZD10/20/30

There are several ways to set the offset compensation:

- Use the vertical knob at the oscilloscope if its function is set to offset.
- Enter the offset value in the channel settings or probe settings on the Rohde & Schwarz oscilloscope.
- Use the micro button to measure input signals with different DC offsets: assign "Offset to mean" to the micro button. See also [Chapter 2.3.2, "Micro Button"](#), on page 17.

For more details, see the oscilloscope's user manual.

2.4.2 Common Mode Offset

Common mode offset compensation is available for R&S RT-ZD probes with serial number $\geq 200\,000$. It can compensate a common DC voltage applied to both input sockets (referenced to the ground socket). This is particularly helpful

for measurements on differential signals with high common mode levels, for example, current measurements using a shunt resistor.

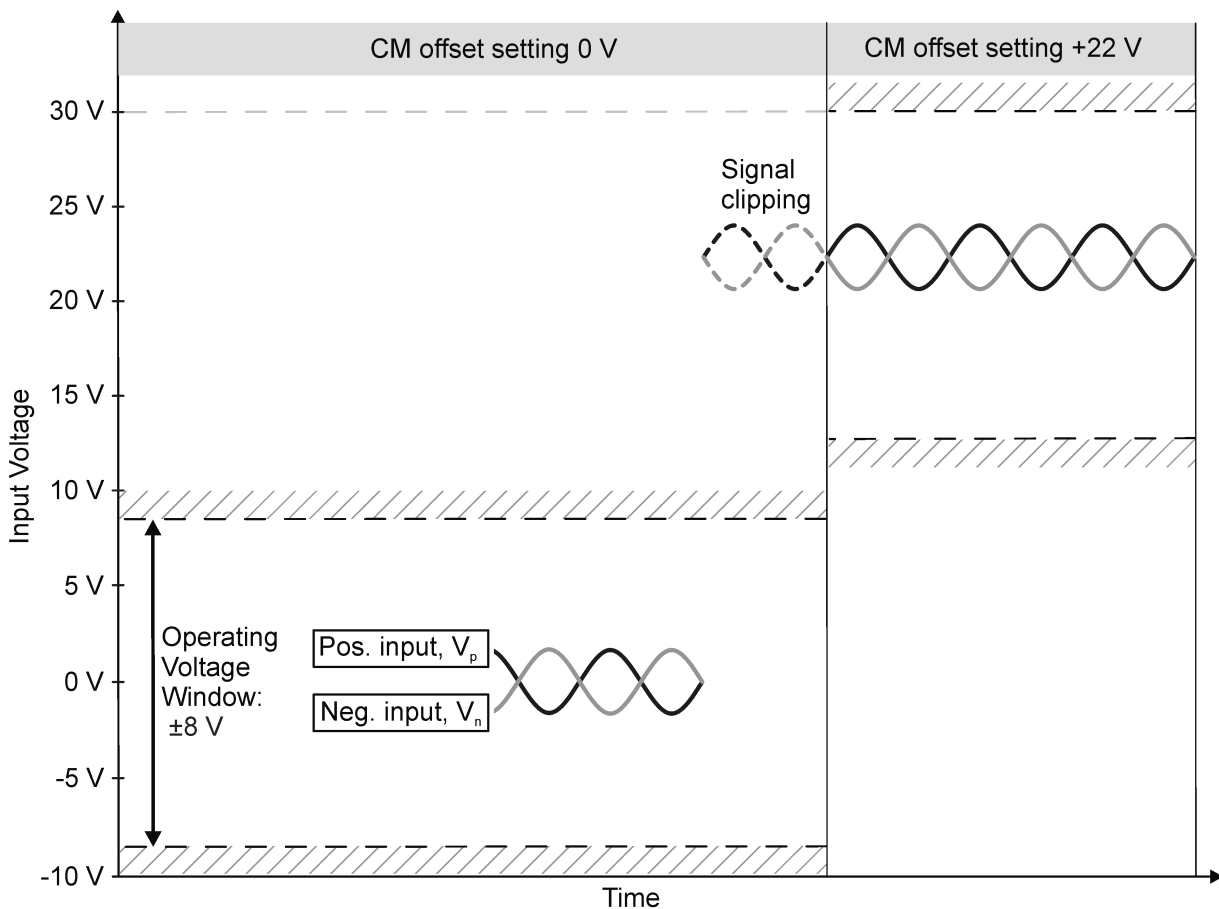

Figure 2-3: Common mode (CM) offset compensation for a differential measurement

If the input signals fit into the operating voltage window of the R&S RT-ZD40, it is not necessary to set a common mode offset compensation.

NOTICE

The R&S RT-ZD40 measures only differential input signals. Common mode signals are suppressed by the probe. Therefore, the common mode offset compensation is not directly visible on the oscilloscope screen, see also [Chapter 4.2, "Dynamic Range and Operating Voltage Window"](#), on page 29. An incorrect common mode offset compensation can lead to unwanted clipping effects. Measuring the common mode input voltage using the R&S ProbeMeter is a convenient way to detect breaches of the operating voltage window.

If supported by the Rohde & Schwarz oscilloscope, you can set the "CM offset" in the probe settings on the instrument. For more details, see the oscilloscope's user manual.

2.4.3 R&S ProbeMeter

The R&S ProbeMeter is an integrated voltmeter that measures DC voltages with higher precision compared to the oscilloscope's DC accuracy. The DC measurement is performed continuously and in parallel to the time domain measurement of the oscilloscope.

High-precision measurements are achieved through immediate digitization of the measured DC voltage at the probe tip.

The R&S ProbeMeter measures the differential and common mode DC voltages simultaneously and without reconnecting the probe. For a definition of differential and common mode input voltages, see [Chapter 4, "Characteristics of Differential Probes"](#), on page 27.

When the R&S ProbeMeter is active, the measured values are displayed on the oscilloscope. The R&S ProbeMeter state is part of the probe settings of the channel to which the probe is connected. For details, refer to the user manual of the Rohde & Schwarz oscilloscope.

Advantages of the R&S ProbeMeter:

- Measures DC voltages of different levels, no need to adjust the measurement range of the oscilloscope.
- True DC measurement (integration time > 100 ms), not mathematical average of displayed waveform.
- High measurement accuracy and low temperature sensitivity.
- Simple means of setting the oscilloscope's trigger level and vertical scaling if a waveform is not visible.
- Independent of oscilloscope settings for offset, position, vertical scale, horizontal scale, and trigger.
- Independent of probe settings for measurement mode and gain.
- Unique way to detect unexpected or inadmissible common mode voltages, e.g. bias points - measurement of common mode DC voltages without reconnecting the probe.
- Differential measurement range $\pm 5\text{ V}$ + offset compensation setting.

Common mode measurement range ± 8 V + common mode offset compensation setting.

The R&S ProbeMeter enables the ground-referenced measurement of voltages. A difference in the ground levels of oscilloscope and DUT can cause an unwanted zero error. In this case, correct the zero error, see [Chapter 2.3.1, "Zero Adjustment"](#), on page 16.

3 Connecting the Probe to the DUT

This chapter describes the different ways of connecting the probe to the DUT. In addition, the accessories supplied are described and their use is explained.

In order to achieve optimum RF performance, the connections should always be as short as possible.

⚠ CAUTION

Risk of injuries

The included probe pins are exceptionally sharp and must be handled with extreme care. To prevent injuries, always use tweezers when inserting or removing pins.



Some solder-in accessories are very fine and sensitive. Stabilize the probe using appropriate means (e.g. adhesive pads, probe positioner) in order to protect the solder joint from excessive mechanical stress.

Pins

Signal pin, solder-in

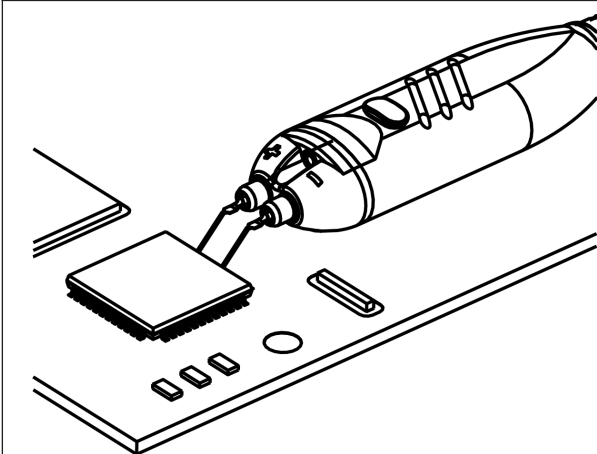

Use tweezers to insert the solder-in pins onto the pins inside the signal sockets of the probe, and then cut to the appropriate length. Try to keep the wires as short as possible. Finally, stabilize the probe, for example by using adhesive tape.

The fine wires on this adapter are best suited to make secure contact with small contact points, such as SMT components or IC pins.

Distance range: 0 mm to 15 mm (0 mil to 600 mil)

Adapters

To insert and adjust the adapters

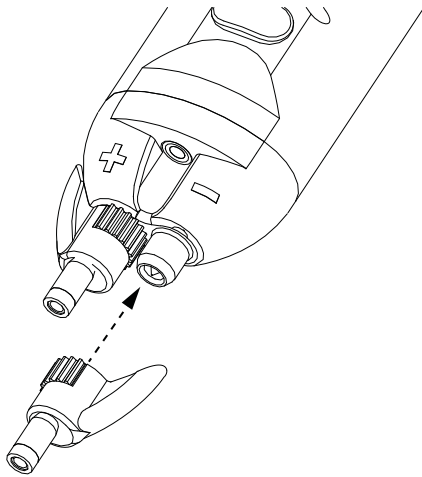

The socket and browser adapters each consist of two separate parts: a red one for the positive socket, and the blue part for the negative socket. The sockets (socket adapter) or pins (browser adapter) are mounted off-center, and the outside is designed like a cogwheel, thus the distance between the pins can be adjusted.

First, insert one part on the appropriate socket. Then insert the second part to the other socket, and make sure that the levers are symmetrical and the cogs are meshing.

To adjust the distance between the sockets/pins, turn the levers. A built-in stop prevents unwanted turning of the signal pins when probing.

Socket adapter

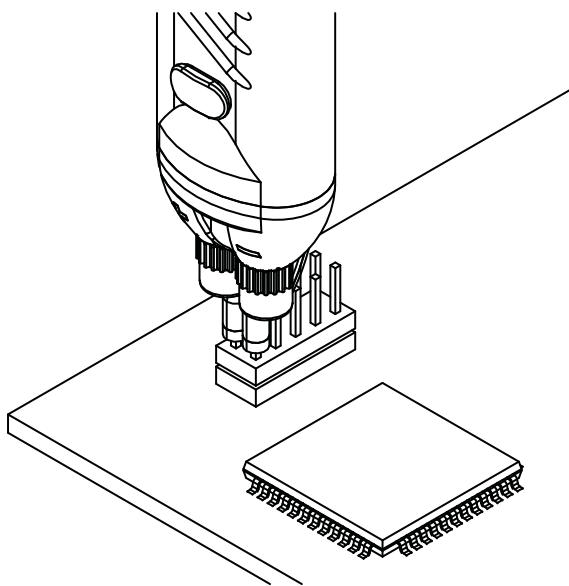

The socket adapter is designed to plug the probe onto pin strips, or for the connection of standard accessories.

Distance range: 2 mm to 5.08 mm (80 mil to 200 mil)

The sockets are compatible with 0.64 mm (25 mil) square pins and 0.6 mm to 0.8 mm (24 mil to 35 mil) round pins.

Browser adapter, rigid and spring-loaded

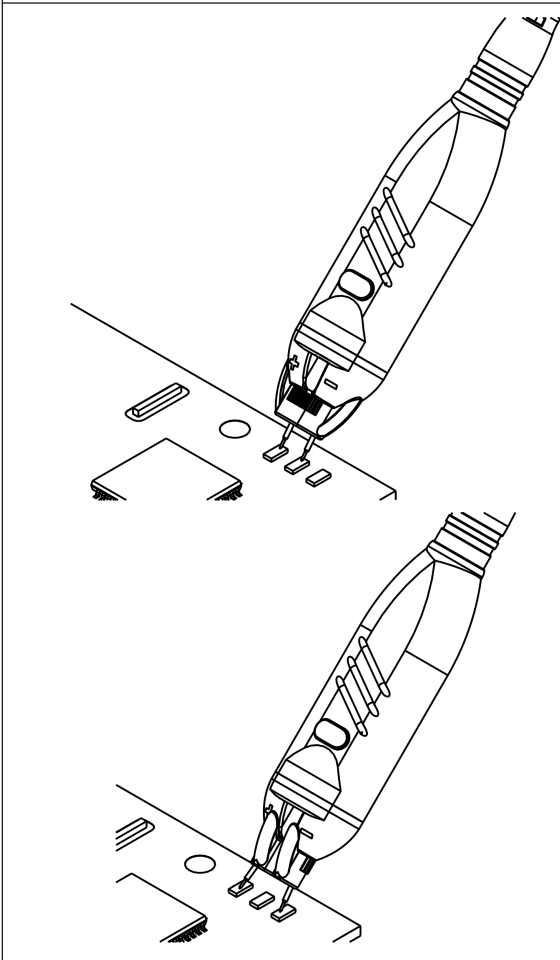

The browser adapter allows handheld probing with maximum convenience. Because it compensates for minor unevenness and movements, it can establish a firm contact to the test point.

Distance range: 0 mm to 6 mm (0 mil to 240 mil)

Leads and clips

Short and long lead

The lead provides a flexible connection to the DUT. It is plugged onto a pin on the DUT and can be used to connect either the signal sockets or the ground socket. In addition, it allows micro and mini clips to be connected to the probe.

Length:

Short lead: 60 mm (236 mil)

Long lead: 150 mm (591 mil)

Mini clip

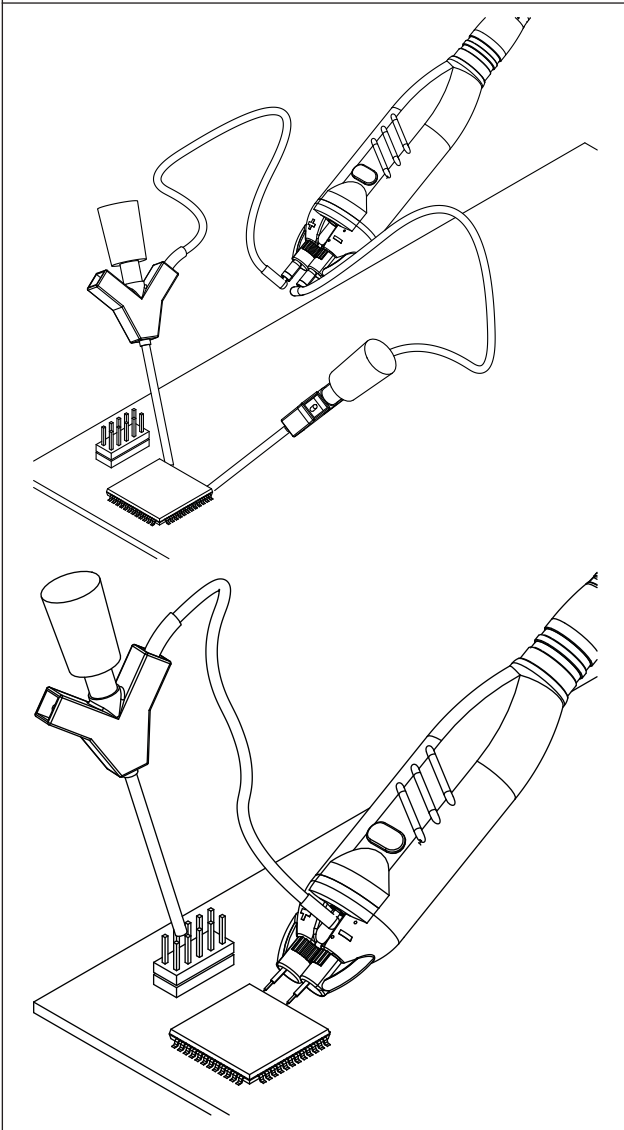

The mini clip is designed for probing large IC pins, wires and through-hole components.

The mini clip is connected to the ground socket using a lead, or it is connected to the signal sockets using the socket adapter and a lead.

Micro clip

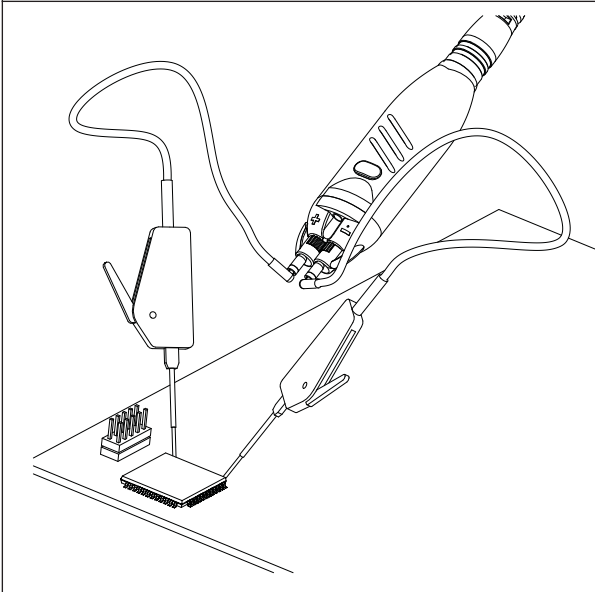

The micro clip is designed for probing IC pins and thin wires in fine-pitch applications.

The micro clip is connected to the ground socket using a lead, or it is connected to the signal sockets using the socket adapter directly or using a lead.

4 Characteristics of Differential Probes

A differential probe has three sockets: the positive signal socket (+), the negative signal socket (-), and the ground socket.

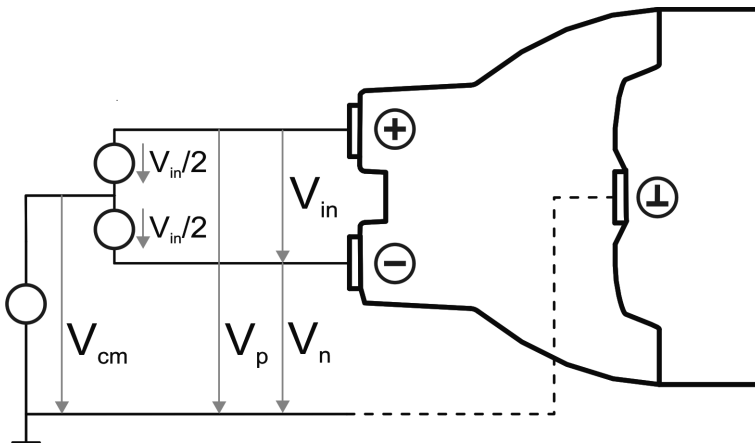

Figure 4-1: Input voltages on a differential probe

Multiple input voltages can be defined for a differential probe:

- Differential mode input voltage (V_{in} , V_{dm})
Voltage between the positive and negative signal sockets
- Positive single-ended input voltage (V_p)
Voltage between the positive signal socket and the ground socket
- Negative single-ended input voltage (V_n)
Voltage between the negative signal socket and the ground socket
- Common mode input voltage (V_{cm})
Mean voltage of positive and negative signal sockets referred to the ground socket, respectively

Two of these voltages are independent values, the other two can be calculated:

$$V_{in} = V_p - V_n$$

$$V_{cm} = \frac{V_p + V_n}{2}$$

Typically, the differential and the common mode input voltages are used to describe the behavior of a differential probe.

Common Mode Rejection Ratio (CMRR)

The output voltage V_{out} , which is displayed on the base unit, is obtained by superimposing the voltages generated from the differential mode input voltage and from the common mode input voltage:

$$V_{out} = A_{vdm}V_{in} + A_{vcm}V_{cm}$$

In this equation, A_{vdm} is the amplification of the differential mode input voltage and A_{vcm} is the amplification of the common mode input voltage.

An ideal differential probe is expressed as $A_{vdm} = 1$ and $A_{vcm} = 0$. In this case, the displayed voltage exactly equals to the differential input voltage V_{in} between the two signal sockets, and the common mode input voltage is suppressed.

4.1 Common Mode Rejection Ratio (CMRR)

An *ideal* differential probe outputs a voltage that depends only on the differential input voltage V_{in} between positive and negative input, and suppresses the common mode voltages. This is equivalent to an infinite common mode rejection ratio (CMRR).

In contrast, real probes have a finite CMRR, resulting in a small part of the common mode voltage visible in the output signal. The CMRR is defined as the ratio of the amplifications of differential and common mode input signals:

$$CMRR = \frac{A_{vdm}}{A_{vcm}}$$

Example:

If a differential input voltage of 1 V yields an output voltage of 100 mV ($A_{vdm} = 0.1$) and a common mode input voltage of 1 V an output voltage of 1 mV ($A_{vcm} = 0.001$), the CMRR is 100 (40 dB).

A high CMRR is important if significant common mode signals are encountered at the probe input, for example:

- DC voltages for setting the operating points of active DUTs
- Different ground levels of probe and DUT, e.g. floating DUTs
- An interference that couples equally to both conductors of a differential transmission line

Dynamic Range and Operating Voltage Window

- Probing on ground-referenced signals. In this case, the common mode component is always equal to half of the input voltage.

4.2 Dynamic Range and Operating Voltage Window

Two separate specifications are necessary to characterize the permissible input voltage range of a differential voltage probe:

- The dynamic range (or "differential mode range") designates the maximum differential voltage V_{in} that may occur between the positive and negative signal pin.
- At the same time, the two voltage values at each of the two signal pins V_p and V_n referenced to the common ground must not exceed a specific limit value. This limitation is referred to as the operating voltage window (some manufacturers also use the less precise term "common mode range" for the same parameter).

If one of these ranges is exceeded, an unwanted signal clipping may occur.

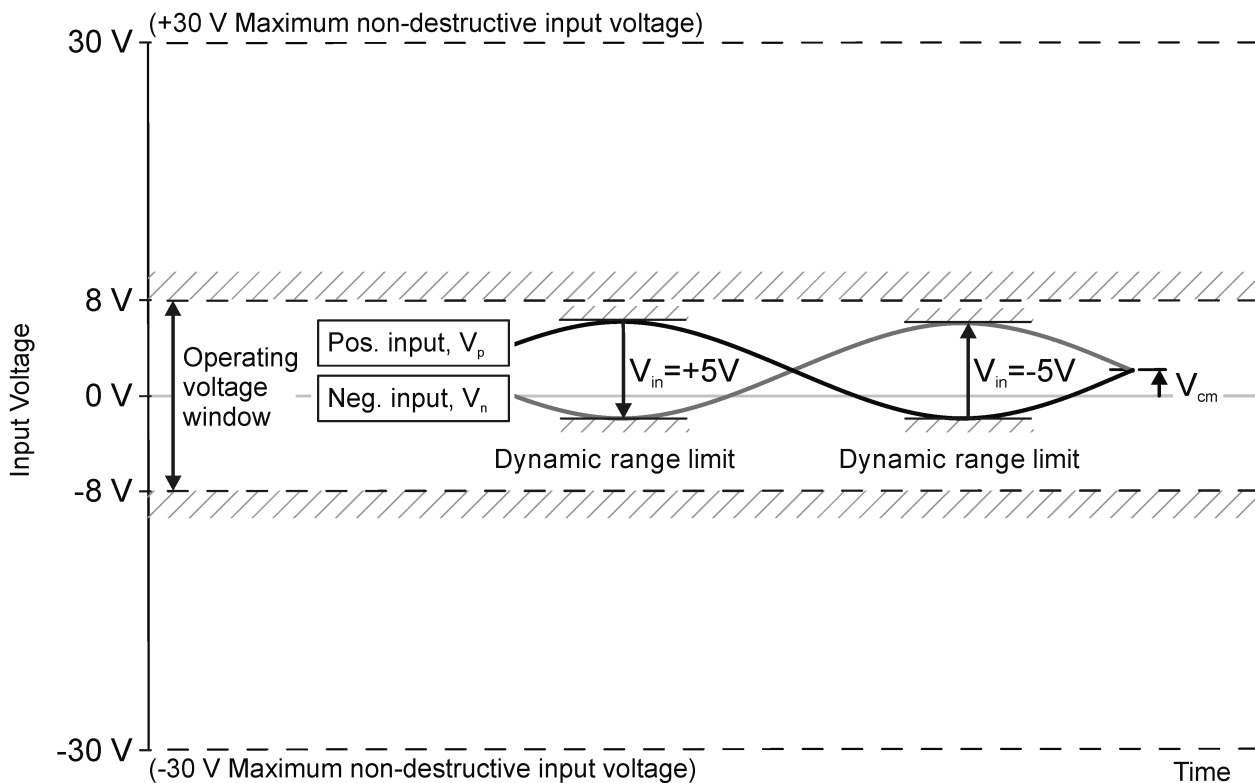

Figure 4-2: Operating voltage window

NOTICE**Signal clipping**

Only differential input signals are detected by the probe and displayed by the base unit. Common mode signals are suppressed by the probe. Therefore, the user does not initially recognize that the operating voltage window is exceeded owing to inadmissible common mode voltages. If unexpected clipping occurs, check the positive or negative input voltage relative to ground.

In addition, measuring the common mode input voltage using the R&S ProbeMeter is a convenient way to detect breaches of the operating voltage window owing to excess DC common mode voltages.

4.3 Ground Connection

It is typically not necessary to connect the ground socket of the probe to the ground of the DUT, as long as the DUT itself is grounded. If the ground of the DUT is floating (such as in the case of battery operation), high static potentials between the DUT ground and the probe ground can result in the operating voltage window of the probe being exceeded. In this case, the probe ground should be connected to the DUT ground.

The ground connection can also affect the CMRR of the probe. Problems with unwanted common mode signals can often be improved by adding a ground connection.

5 Measurement Principles

The R&S RT-ZD40 differential probe provides an electrical connection between the DUT and the oscilloscope. The probe transfers the voltage of the electrical signal tapped off the DUT to the oscilloscope, where it is displayed graphically. Although a probe has a wide variety of specifications, these specifications can be grouped into two classes of basic requirements:

- High signal integrity of the transferred signal:
With an ideal probe, the output signal that is transferred to the base unit is identical to the input signal between the probe tips, and signal integrity is extremely high. Every real probe, however, transfers the input signal in altered form. A good probe causes only minimum alterations.
How the probe can fulfill this requirement is mainly determined by its bandwidth and CMRR.
- Low loading of the input signal:
Every probe is a load for the signal to be measured. The signal to be measured changes when the probe is connected. A good probe causes only a minimum change to the signal, so that the function of the DUT is not adversely affected.
How the probe can fulfill this requirement is mainly determined by its input impedance.

The parameters of a probe are usually specified for a minimally short connection between the probe and the DUT. With longer connections, the connection inductance has a significant effect on the measurement.

The high-frequency behavior of differential probes is typically characterized in the following environment. The probe is connected to a differential 100 Ω line that is fed by a source with 100 Ω internal impedance and that is terminated into 100 Ω . The voltages at both inputs of the probe are always oppositely equal. The [Figure 5-1](#) shows the equivalent circuit model of a probe that is connected to the DUT.

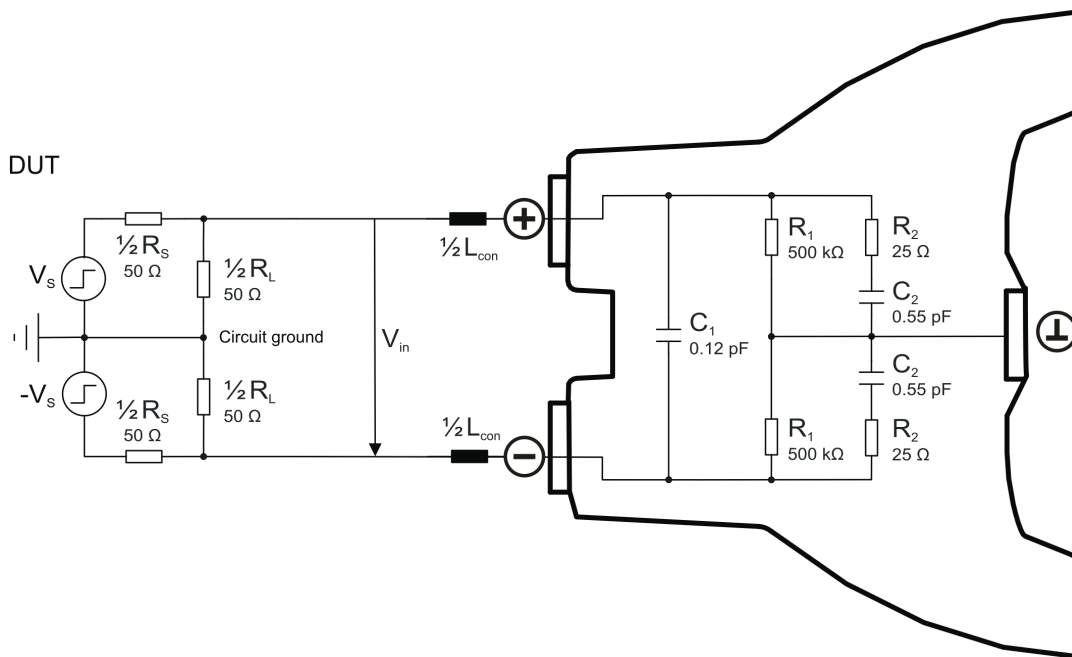

Figure 5-1: Equivalent circuit model of the R&S RT-ZD40 probe

Table 5-1: Designations

Abbreviation	Description
V_s	Differential voltage between the test point without probe connected
V_{in}	Differential voltage at the test point with probe connected, corresponds to the input voltage of the probe
R_s	Differential source resistance of the DUT
R_L	Differential load resistance of the DUT
R_1, R_2	Probe-specific input resistance
C_1, C_2	Probe-specific input capacitance
L_{con}	Parasitic inductance of the probe connection

5.1 Signal Integrity of the Transferred Signal

The following sections describe the effect that bandwidth, connection inductance and common mode rejection ratio have on signal integrity.

5.1.1 Bandwidth

The bandwidth BW of a probe is one of its specific parameters. The bandwidth of the probe and the bandwidth of the base unit together form the system bandwidth. The following explanations refer to the probe itself, but can also be applied to the entire system.

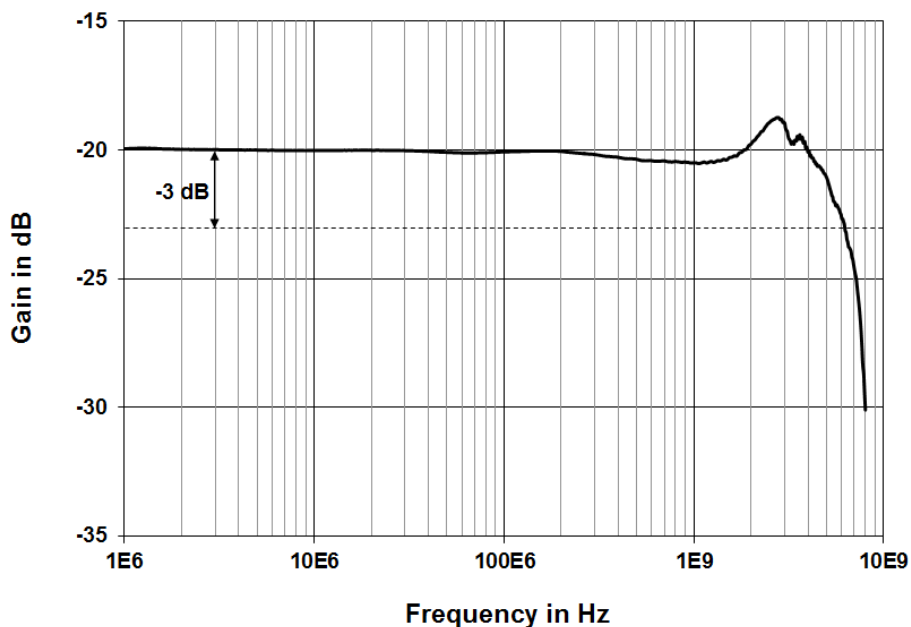

Figure 5-2: Amplitude frequency response of the R&S RT-ZD40

The bandwidth:

- Specifies the maximum frequency at which a purely sinusoidal signal is still transferred at 70 % (–3 dB) of its amplitude.
- Specifies the transferable spectrum for other waveforms. E.g., with square wave signals, the fifth harmonic should still be within the bandwidth for a high signal integrity.
- Determines the minimum measurable signal rise time. The rise time t_{rise} of the probe is inversely proportional to its bandwidth. The following approximation applies:

$$t_{rise} \approx \frac{0.4}{BW}$$

The [Figure 5-3](#) shows a typical step response of an R&S RT-ZD40 differential probe.

In addition to bandwidth, a constant amplitude frequency response of the probe is decisive for high signal integrity. The [Figure 5-2](#) shows the typical amplitude frequency response of an R&S RT-ZD40 differential probe. All frequency components are transferred with the same gain so that the input signal is displayed without distortion.

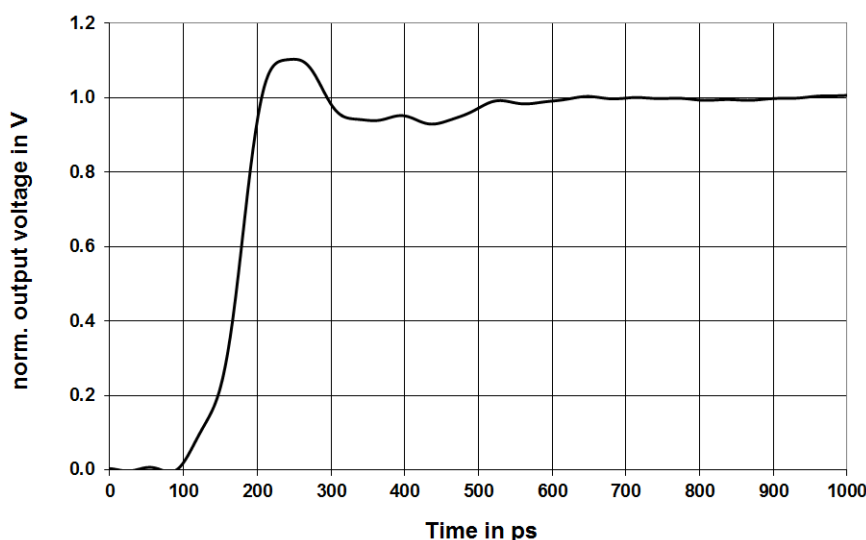

Figure 5-3: Step response of the R&S RT-ZD40

5.1.2 Connection Inductance

The connection inductance L_{con} is caused by connecting the probe to the DUT. In contrast to the probe-specific bandwidth, the connection inductance mainly depends on the selected type.

The connection inductance:

- Increases with the length of the connection and the size of the resulting loop area A .
See [Figure 5-4](#).
- Reduces the usable bandwidth and causes ringing with signals having a short rise time, due to a series resonance with the input capacitance.

Signal Integrity of the Transferred Signal

- Must be as small as possible (short lead length) to maintain high signal integrity.

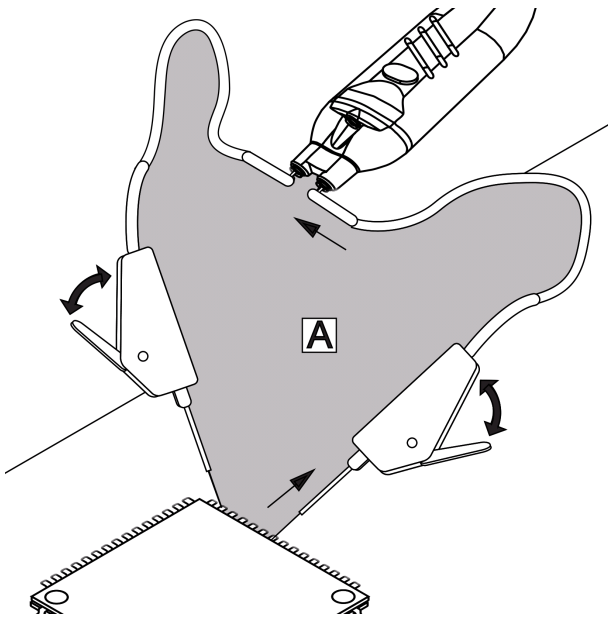

$$L_{con} \text{ proportional to } A$$

$$f_{resonance} \approx \frac{1}{2\pi\sqrt{L_{con} \cdot C_{in}}}$$

$$BW \text{ proportional to } \frac{1}{\sqrt{L_{con}}}$$

Figure 5-4: Ground connection and connection inductance using the example of R&S RT-ZD10/20/30

The [Table 5-2](#) shows different types of connections between the probe and DUT as well as the associated connection inductance L_{con} . The table also includes typical bandwidth values, rise time values, and the step responses for each connection in conjunction with an R&S RT-ZD40.

Table 5-2: Connection inductance L_{con} , typical bandwidth, rise time and step response with different types of connection

Type of connection	Connection inductance L_{con}	Typ. bandwidth and rise time	Step response
Very short signal pins, solder-in (5mm) Short browser adapters	~2 nH	> 5.5 GHz < 75 ps	
	~3 nH	> 5 GHz < 80 ps	
Long signal pins, solder-in (10 mm) socket adapters, variable spacing	~6 nH	> 3 GHz < 150 ps	
	~60 nH	500 MHz very long settling time	
Very long leads micro clips mini clips			

5.1.3 CMRR

The CMRR is very good for low-frequency signals, but it continuously decreases for higher frequencies. Therefore, the CMRR is usually specified as a function of frequency.

The [Figure 5-5](#) shows a typical CMRR for an R&S RT-ZD40 differential probe with a very symmetrical connection to the DUT. An asymmetrical connection to the test point can decrease the CMRR. To achieve the best possible CMRR, the connection to the DUT should always be as symmetrical as possible.

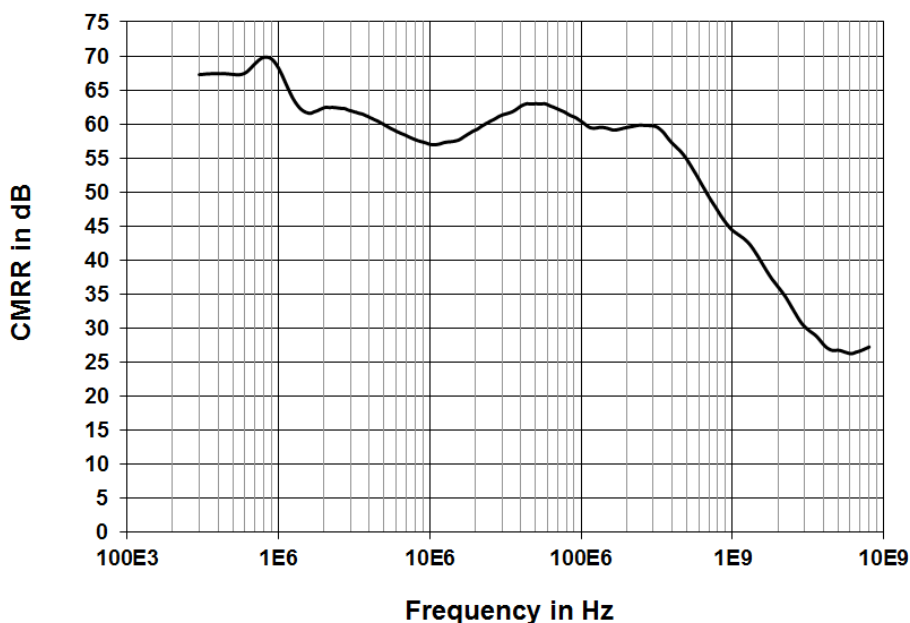

Figure 5-5: Typical CMRR of the R&S RT-ZD40 probe as a function of frequency

5.2 Signal Loading of the Input Signal

The previous section explained the transfer function and step response of the probe. This section describes how the probe influences the input signal. The input signal loading caused by the probe is determined by its input impedance. In general, the probe causes only low signal loading because its input impedance is usually much greater than the source impedance of the test circuit.

5.2.1 Signal Loading for Differential Input Signals

The [Figure 5-1](#) presents an equivalent circuit model of an R&S RT-ZD40 differential probe. The differential input impedance of the probe is equal to the impedance between its positive (+) and the negative (-) signal socket. The resulting input impedance versus frequency is indicated in [Figure 5-6](#).

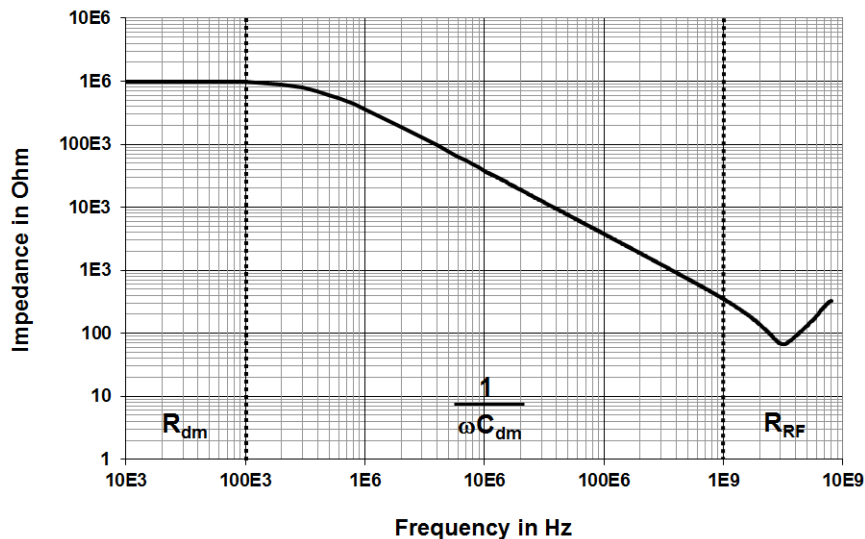

Figure 5-6: Magnitude of the differential input impedance of the R&S RT-ZD40 probe as a function of frequency

The differential input impedance varies greatly versus the frequency and is defined by the following values:

- Differential input resistance $R_{dm} = 2 R_1$
- Differential input capacitance $C_{dm} = C_1 + C_2 / 2$
- Differential RF resistance $R_{RF} = 2 R_2$

5.2.1.1 Input Resistance R_{dm}

The input resistance determines the loading of the DUT at DC and very low frequencies (< 100 kHz). A low input resistance can potentially disturb measurements of high-frequency signals as it influences the DC operating point of active components. This effect is negligible for the majority of applications involving the R&S RT-ZD40 probe due to the very high input resistance of the probe (1 M Ω).

5.2.1.2 Input Capacitance C_{dm}

The input capacitance C_{dm} causes the input impedance to decrease in the medium-frequency range (100 kHz to 1.0 GHz). It affects the settling time of the input voltage in the case of fast transients.

5.2.1.3 RF Resistance R_{RF}

The RF resistance R_{RF} determines the minimum input impedance and thus the maximum loading at very high frequencies above 1.0 GHz. Thus, the measurement result depends on the source impedance of the DUT. The RF resistance R_{RF} prevents the input voltage from rising immediately to its final value in the case of fast transients.

The resulting loading of a step signal at the input of the probe is shown in [Figure 5-7](#).

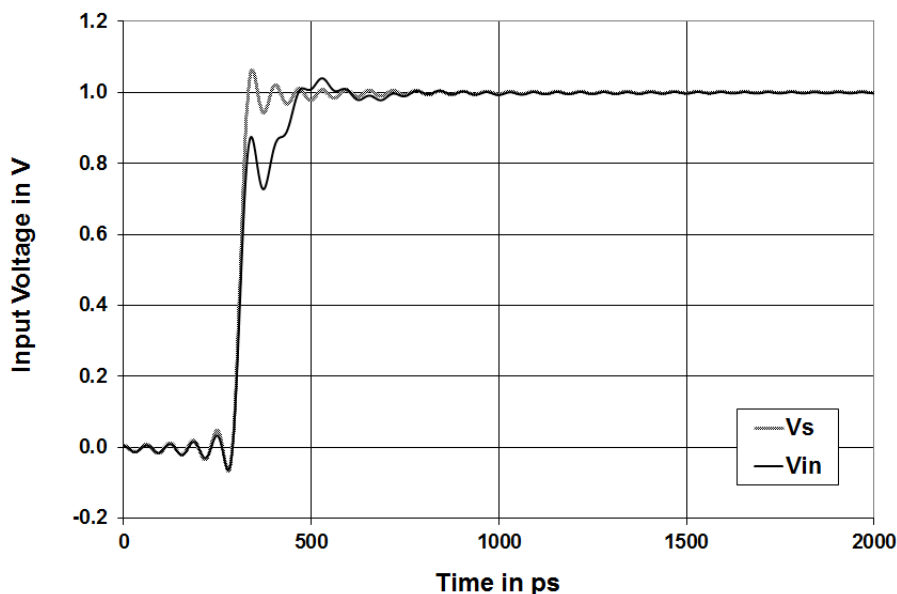

Figure 5-7: Signal loading caused by the R&S RT-ZD40 probe

5.2.2 Signal Loading for Non-Differential Input Signals

As described in [Chapter 4, "Characteristics of Differential Probes"](#), on page 27, various types of input signals can be measured with a differential probe. Every type of input signal has an associated input impedance.

- For differential input signals, the input impedance of the probe is the impedance between its positive and negative signal sockets.
- For single-ended input signals, the input impedance is the impedance between the positive or negative signal socket and the ground socket.
- For common mode input signals, the input impedance is the impedance between the parallel connection of the positive and negative signal sockets and the ground socket.

The equivalent circuit diagram in [Figure 5-1](#) can be used to determine the associated input impedance. The [Table 5-3](#) provides as an example the DC input resistance for several input signals.

Table 5-3: DC Input Resistance for Various Input Signals

Type of input signal	Differential	Single-ended	Common mode
Input Resistance	1 MΩ	500 kΩ	250 kΩ

This table shows that common mode signals suffer the highest loading. This characteristic of all differential probes is particularly bothersome because common mode signals frequently have a very high source resistance (e.g. 10 kΩ for conventional fail-safe circuits). While the input resistance achieved for common mode voltages with the R&S RT-ZD40 differential probe remains sufficiently high, probes with lower input resistances can lead to unfavorable loading effects.

5.3 Probing Philosophy

The previous sections explained that probes exert a load on the signal to be measured and change its characteristic. The signal at the test point where the probe makes contact (V_{in}) is therefore different from the signal that was present before the probe was connected (V_S). This effect cannot be avoided and occurs with all real probes – independent of type and manufacturer.

As a result, there are different opinions which signal is the better output of the probe:

- The initial signal that is not loaded by the probe (V_S), and that corresponds to the signal at the test point without the probe being connected.
- The input signal that is loaded with the input impedance of the probe (V_{in}) and that is present between the probe tips.

Both approaches are physically correct and have their individual advantages and disadvantages. In theory, it is even possible to convert mathematically the two measurement results into each other, but conversion is a complex transformation to and from the frequency domain. Probe manufacturers use one or the other of these two approaches.

Rohde & Schwarz has decided in favor of the user-friendly approach. In our opinion, most users want to know the signal present in the DUT before it was altered by the influence of the probe. Their goal is to characterize the DUTs, not the probe.

If measurements are carried out in a $100\ \Omega$ (or a comparable) environment, the signal displayed on the oscilloscope screen is always a direct representation of the unloaded signal V_S , see [Figure 5-8](#).

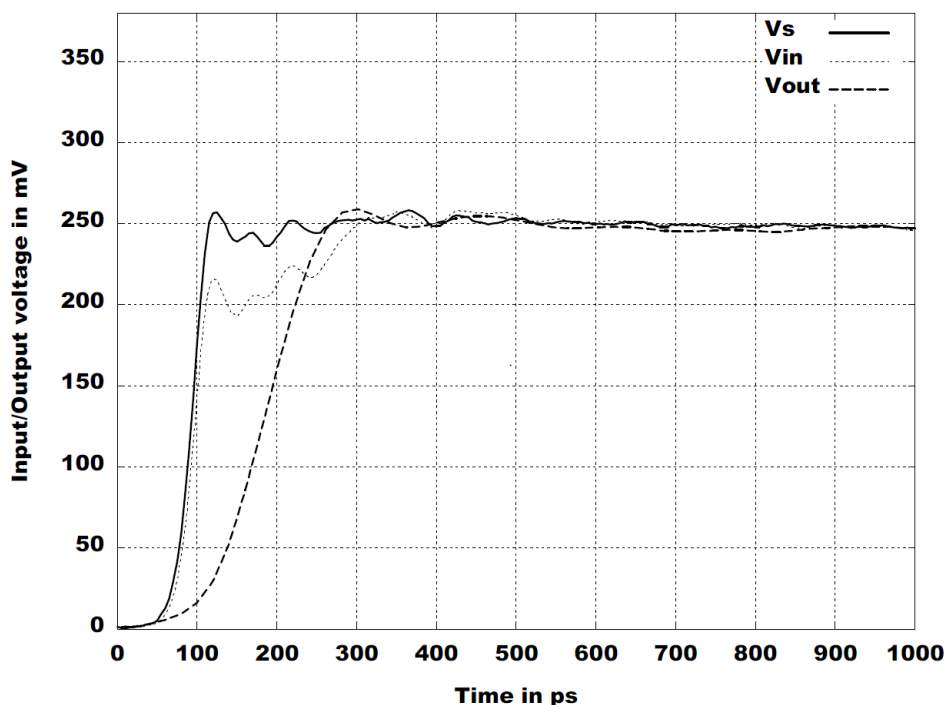

Figure 5-8: Unloaded and loaded input signal and step response (for RT-ZS30)

6 Maintenance and Service

Like all Rohde & Schwarz products, Rohde & Schwarz probes and adapters are of high quality and require only minimum service and repair. However, if service or calibration is needed, contact your Rohde & Schwarz service center. Return a defective product to the Rohde & Schwarz service center for diagnosis and exchange.

6.1 Cleaning

1. Clean the outside of the product using a soft cloth moistened with either distilled water or isopropyl alcohol. Keep in mind that the casing is not waterproof.
Note: Do not use cleaning agents. Solvents (thinners, acetone), acids and bases can damage the labeling or plastic parts.
2. Dry the product completely before using it.

6.2 Contacting Customer Support

Technical support – where and when you need it

For quick, expert help with any Rohde & Schwarz equipment, contact one of our Customer Support Centers. A team of highly qualified engineers provides telephone support and works with you to find a solution to your query on any aspect of the operation, programming or applications of Rohde & Schwarz equipment.

Up-to-date information and upgrades

To keep your instrument up-to-date and to be informed about new application notes related to your instrument, please send an e-mail to the Customer Support Center stating your instrument and your wish. We will make sure that you get the right information.

Europe, Africa, Middle East

Phone +49 89 4129 12345

customersupport@rohde-schwarz.com

North America

Phone 1-888-TEST-RSA (1-888-837-8772)

customer.support@rsa.rohde-schwarz.com

Latin America

Phone +1-410-910-7988

customersupport.la@rohde-schwarz.com

Asia/Pacific

Phone +65 65 13 04 88

customersupport.asia@rohde-schwarz.com

China

Phone +86-800-810-8228 / +86-400-650-5896

customersupport.china@rohde-schwarz.com

6.3 Returning for Servicing

Use the original packaging to return your R&S RT-ZD40 to your Rohde & Schwarz service center. A list of all service centers is available on:

www.services.rohde-schwarz.com

If you cannot use the original packaging, consider the following:

1. Use a sufficiently sized box.
2. Protect the product from damage and moisture (e.g. with bubble wrap).
3. Use some kind of protective material (e.g. crumpled newspaper) to stabilize the product inside the box.

4. Seal the box with tape.
5. Address the package to your nearest Rohde & Schwarz service center.

6.4 Calibration Interval

The recommended calibration interval for R&S RT-ZD40 differential probe is two years. For servicing, send the probe to your nearest Rohde & Schwarz service center (see [Chapter 6.3, "Returning for Servicing"](#), on page 43).

6.5 Discarding the Product

Handle and dispose the product in accordance with local regulations.

6.6 Spare Parts

The following accessories can be ordered at the Rohde & Schwarz service center. Use the order numbers provided in the following table.

Table 6-1: Accessories spare parts

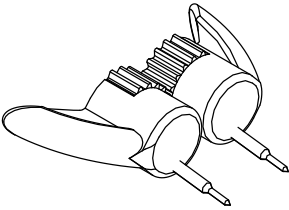
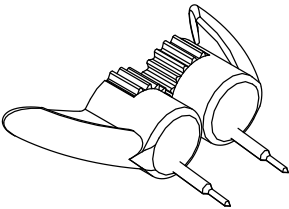
Pos	Item	Description	Material Number
1		Browser adapter, spring loaded	1417.0680.00
2		Browser adapter, rigid	1417.0673.00

Pos	Item	Description	Material Number
3		Socket adapter, variable spacing	1417.0667.00
4		Lead, 6 cm / 2.4 in	1416.0128.00
6		Lead, 15 cm / 5.9 in	1416.0134.00
6		Mini clip	1416.0105.00
7		Micro clip	1416.0111.00
8		Marker band kit	1416.0205.00
9		Signal pin, solder-in	1417.0838.00
10	Pogo pin	Pogo pin connector, 6 pins	3584.6396.00
11	R&S RT-ZK2	R&S RT-ZK2 service kit	1410.5305.02

Table 6-2: Parts for ESD prevention

Pos.	Item	Material number
1	ESD wrist strap	0008.9959.00
2	ESD grounding cable	1043.4962.00

7 Functional Check

The functional check confirms the basic operation of the R&S RT-ZD40 differential probe. The functional check is not suitable for verifying compliance with the probe specifications.

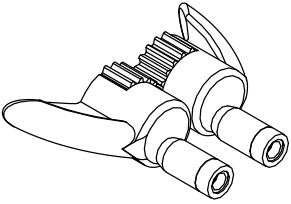
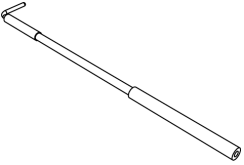
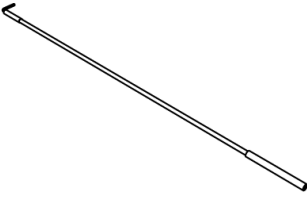
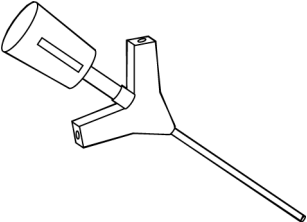
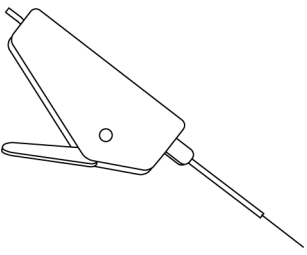
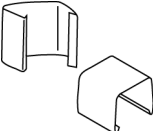
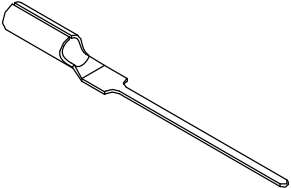
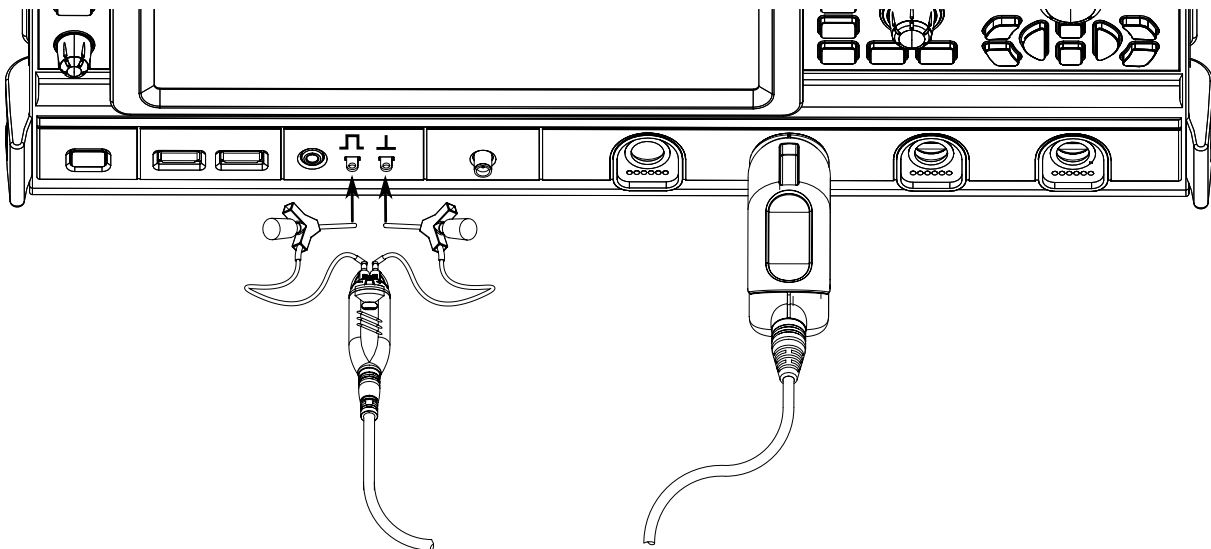

1. Connect the R&S RT-ZD40 to a Rohde & Schwarz oscilloscope as described in [Chapter 2.1, "Connecting the Probe to the Oscilloscope"](#), on page 15.
2. Connect a socket adapter to the signal sockets.
3. Using a short lead and a mini clip, connect one of the signal sockets to the square wave output \square of the oscilloscope.
4. Using a short lead and a mini clip, connect the other signal socket to the probe ground connector \perp of the oscilloscope.
5. Press the [Preset] key and then the [Autoset] key on the oscilloscope.
A square wave with 1 V amplitude between 0 V and 1 V is displayed on the display.
6. Reverse the pins at the probe and repeat [step 5](#).

Index

- A**
- Accessories 11
 - AutoZero 16
- B**
- Bandwidth 6, 33
- C**
- Cleaning 42
 - Clipping 30
 - Clips 12
 - CMRR 28, 37
 - Common mode input voltage 27
 - Common mode range 29
 - Common mode rejection ratio 37
 - Common Mode Rejection Ratio 28
 - Connecting to DUT 22
 - Connecting to oscilloscope 15
 - Connection inductance 34
- D**
- Data memory 7
 - DC measurement 20
 - Differential input voltage 27, 30
 - Dynamic range 6, 29
- E**
- Electrostatic discharge 15
 - ESD 15
- F**
- Functional check 47
- G**
- Ground connection 30
- I**
- Inductance 34
 - Input capacitance 6
 - Input resistance 6
 - Input voltages 27
- L**
- Leads 13
 - Loading 37
- M**
- Micro button 6, 17
- N**
- N/USB adapter 13
- O**
- Operating voltage window 29
- P**
- Pins
 - Inserting and removing 22
 - Probe box 9
 - Probe head 8
 - Probe identification 16
 - ProbeMeter 6, 20
 - Probing principles 31
 - Product description 5
- S**
- Service kit 13
 - Service manual 13
 - Signal clipping 29
 - Signal integrity 33
 - Signal loading 37
 - Single-ended input voltage 27
 - Step response 34
- U**
- Unpacking 7
 - Using accessories
 - Adapter 23
 - Browser adapter 24
 - Leads 24
 - Micro clip 26
 - Mini clip 25
 - Signal pins 22
- Z**
- Zero error correction 16