

Fox Thermal

THERMAL MASS FLOW METER
& TEMPERATURE TRANSMITTER



Model FT2A



Notice

This publication must be read in its entirety before performing any operation. Failure to understand and follow these instructions could result in serious personal injury and/or damage to the equipment. Should this equipment require repair or adjustment beyond the procedures given herein, contact the factory at:

**FOX THERMAL INSTRUMENTS, INC.
399 RESERVATION ROAD
MARINA, CA 93933
TELEPHONE: 831-384-4300
FAX: 831-337-5787
EMAIL: SERVICE@FOXTHERMAL.COM**

**Download Technical Data Sheets from our website:
www.foxthermal.com**

Fox Thermal believes that the information provided herein is accurate; however, be advised that the information contained herein is NOT a guarantee for satisfactory results. Specifically, this information is neither a warranty nor guarantee, expressed or implied, regarding performance, merchantability, fitness, or any other matter with respect to the products; nor recommendation for the use of the product/process information in conflict with any patent. Please note that Fox Thermal reserves the right to change and/or improve the product design and specification without notice.



Fox FT2A Manuals:

- Fox FT2A Modbus / BACnet MS/TP Manual
- Fox FT2A Profibus, DeviceNet, Ethernet Manual
- Fox FT2A View™ Manual

All Fox Manuals and software available in English only.

Table Of Contents

1. Introduction	Page 6
2. Installation (Mechanical)	Page 9
a. Straight run requirements	Page 10
3. Wiring (Electrical)	Page 20
a. Local Wiring	Page 23
b. Input Power	Page 23
c. Signal Wiring	Page 25
d. Alarm Wiring	Page 28
e. Remote Switch	Page 29
f. Remote Wiring	Page 31
4. Operation (Standard Operation)	Page 32
a. Start Up	Page 32
b. Display Screens	Page 33
c. Engineering Screens	Page 34
d. Programming	Page 35
e. Menu Trees	Page 54
5. Maintenance	Page 62
6. Troubleshooting	Page 68
7. Appendices	Page 74
a. Specifications	Page 74
b. Agency Approvals	Page 77
c. FT2A with 2 Gas Curves	Page 78
d. Dimensions	Page 82
e. Mounting the FT2A Enclosure	Page 90
f. Warranty	Page 92
g. Returning your meter	Page 93
8. Glossary of Terms and Abbreviations	Page 94
9. Index	Page 96

Introduction: Quick Start Guide

Use the table below as a guide while using the worksheet on the next page to record your notes.
NOTE! Please read the entire quick-start procedure before beginning installation.

INTRODUCTION

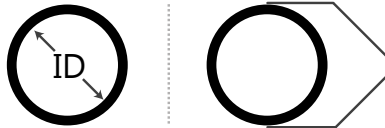
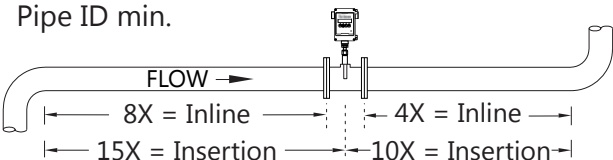
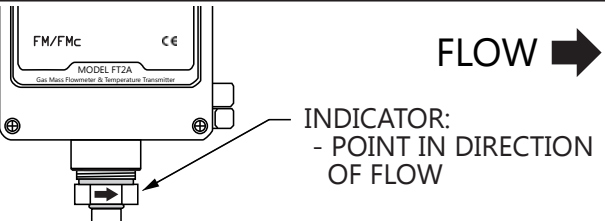
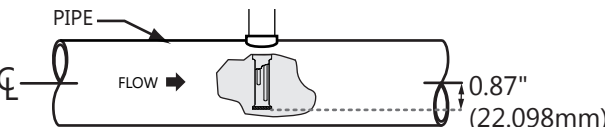
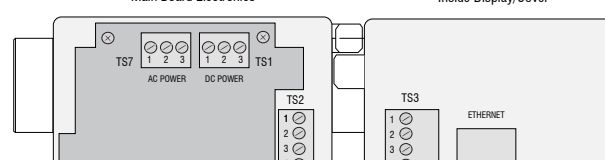
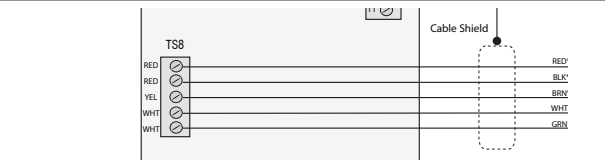
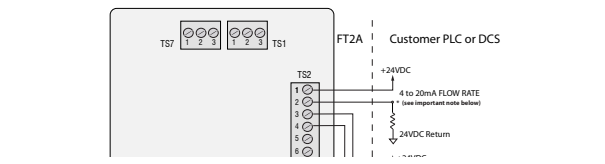
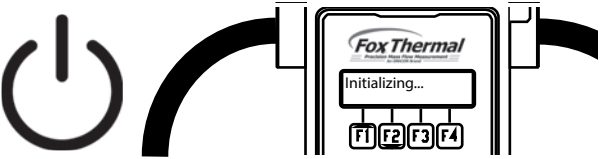
1.	Record inside diameter (ID). Ensure the actual pipe ID matches the pipe ID shown on the factory calibration certificate. If IDs do not match, refer to p. 423.	
2.	Record up/downstream straight-pipe requirements based on Pipe ID and meter style (insertion or inline). [refer to p. 19]	
3.	The Flow Direction Indicator must point in the direction of flow.	
4.	Ensure correct probe depth setting. If using 1 1/2" size pipe, please see note on p. 21.	
5.	Ensure power wiring and 4-20mA wiring properly connected. [refer to p. 30 - p. 32 for more information]	
6.	Ensure remote wiring is correct if remote option ordered. [refer to p. 38 - p. 39 for more information]	
7.	Verify you have the proper output signal wiring [refer to p. 33 - p. 36 for more information]	
8.	Power on the flow meter.	
9.	Check the remaining flow meter settings by accessing the meter settings either through the front panel of the display or by using the FT2A View™ software tool. Record the settings in the spaces given for items A - E on the following page.	

Introduction: Quick Start Guide

Before powering on your meter, use this worksheet to record your notes.

	<i>Item to verify</i>	<i>Serial Number:</i>	<i>Serial Number:</i>	<i>Serial Number:</i>	<i>Serial Number:</i>
1.	What is the Pipe ID?	ID =	ID =	ID =	ID =
2.	Calculate the Upstream/ Downstream straight-pipe requirements	UP = DN =	UP = DN =	UP = DN =	UP = DN =
3.	a. Is the flow indicator pointed in direction of flow?	Y / N	Y / N	Y / N	Y / N
4.	Is the probe depth setting correct?	Y / N	Y / N	Y / N	Y / N
5.	Verify proper power wiring setup				
6.	Verify proper remote wiring setup (if ordered)				
7.	Verify proper input/output wiring setup				

After powering on your meter, check items A - E below by accessing the meter settings either through the front panel of the meter's display or by using the FT2A View™ software tool.

A.	Which flow units have been set in meter? (SCFM, KG/H, etc..)				
B.	Correct values for reference temperature and pressure?	Y / N	Y / N	Y / N	Y / N
C.	Confirm the pipe ID listed above same as "Pipe_id="				
D.	Verify the 1st 4mA and 20mA meter settings	4mA = 20mA =	4mA = 20mA =	4mA = 20mA =	4mA = 20mA =
E.	Verify the 2nd 4mA and 20mA meter settings	4mA = 20mA =	4mA = 20mA =	4mA = 20mA =	4mA = 20mA =

Your Notes:

If you are experiencing any problems after completing this procedure, please call the Fox Thermal Service Department at 831-384-4300 to review this information.

Introduction

Thank you for purchasing the Model FT2A Thermal Gas Mass Flow Meter and Temperature Transmitter from Fox Thermal. The Model FT2A is one of the most technically advanced flow meters in the world. Extensive engineering effort has been invested to deliver advanced features, accuracy measurement performance and outstanding reliability.

This Instruction Manual contains the electrical and mechanical installation instructions as well as details for programming, maintaining and troubleshooting the meter.

This manual is divided into the following sections: Introduction, Installation, Wiring, Operation, Maintenance, Troubleshooting, Appendices, Glossary and Index.

Theory of Operation

The Model FT2A is an innovative Thermal Mass Gas Flow Meter and Temperature Transmitter. It is microprocessor-based and field programmable. The FT2A thermal sensor operates on the law that gases absorb heat. A heated sensor placed in an air or gas stream transfers heat in proportion to the stream's mass velocity. There are two sensor elements connected to a balanced bridge circuit. One sensor element detects the gas temperature and a second element is maintained at a constant temperature above the gas temperature. The energy applied to the heated sensor to maintain a constant temperature differential (constant ΔT) is directly proportional to the mass flow velocity. The FT2A flow meter maintains accurate flow measurement over a large temperature and pressure range.

Mass Flow

The Model FT2A measures mass flow; an advantage over other flow meters which measure volumetric flow rate. Volumetric flow is incomplete because temperature and pressure are unknown and must be measured separately. For example, the mass flow of a gas depends on its temperature and pressure. As temperature and pressure changes, the gas volume changes but not its mass. Therefore a device measuring mass flow is independent of temperature and pressure. The Model FT2A provides a direct measurement of gas flow in Mass units (kg/hr, lb/hr), standard units (SCFM, SLPM) or normal units (NM³/hr, NLPM) with no additional temperature or pressure measurements required.

Introduction

Flow Calibration

The Fox Calibration Lab maintains instrument calibration records on every flow meter. This data can also be accessed via a computer using FT2A View™ software within the instrument. Computer-generated calibration documents describe specific instrument details that can be sorted by serial number, tag number or customer purchase order.

Calibration files include details on process conditions, calibration fluid, line size and other information. All NIST-traceable equipment utilized for the calibration procedure is identified, as is the calibration history of all reference equipment.

In addition to the Calibration Certificate, a certified flow table that correlates current outputs with scaled units of flow is produced for each calibrated device.

I/O Description

The FT2A features two galvanically isolated 4-20mA analog outputs, one isolated digital output, one discrete input and a USB port for communication with a computer.

The first 4-20mA output is for flow rate. The second 4-20mA output can be configured either for flow rate or process gas temperature. Both 4-20mA outputs can be scaled by the user. The digital output can be used for frequency or alarm, is programmable to represent flow rate and can be scaled for maximum flow/maximum frequency, units-per-pulse or pulse-per-units. The maximum frequency is 100 Hz.

FT2A View™ interfaces to the USB port and is a free Fox PC-based software program that displays flow meter readings and permits flow meter configuration. The software is available for download on the Fox website.

Industry standard communication options are available including optional RS485 Modbus, BACnet MS/TP, Profibus-DP, DeviceNet, or Ethernet Modbus TCP. These serial communication options can be selected when ordering the meter. Modbus and BACnet may be enabled after purchase.

Introduction

FT2A Functional Diagram

An on-board 2 line x 16 character backlit LCD display shows flow rate, total flow, elapsed time, process gas temperature and alarms. The display is also used in conjunction with the Configuration Panel for field configuration of flow meter settings such as 4-20mA scaling, frequency output scaling, pipe area, zero flow cutoff, flow filtering or damping, display configurations, diagnostics and alarm limits.

Fig. 1.1: FT2A Function Diagram

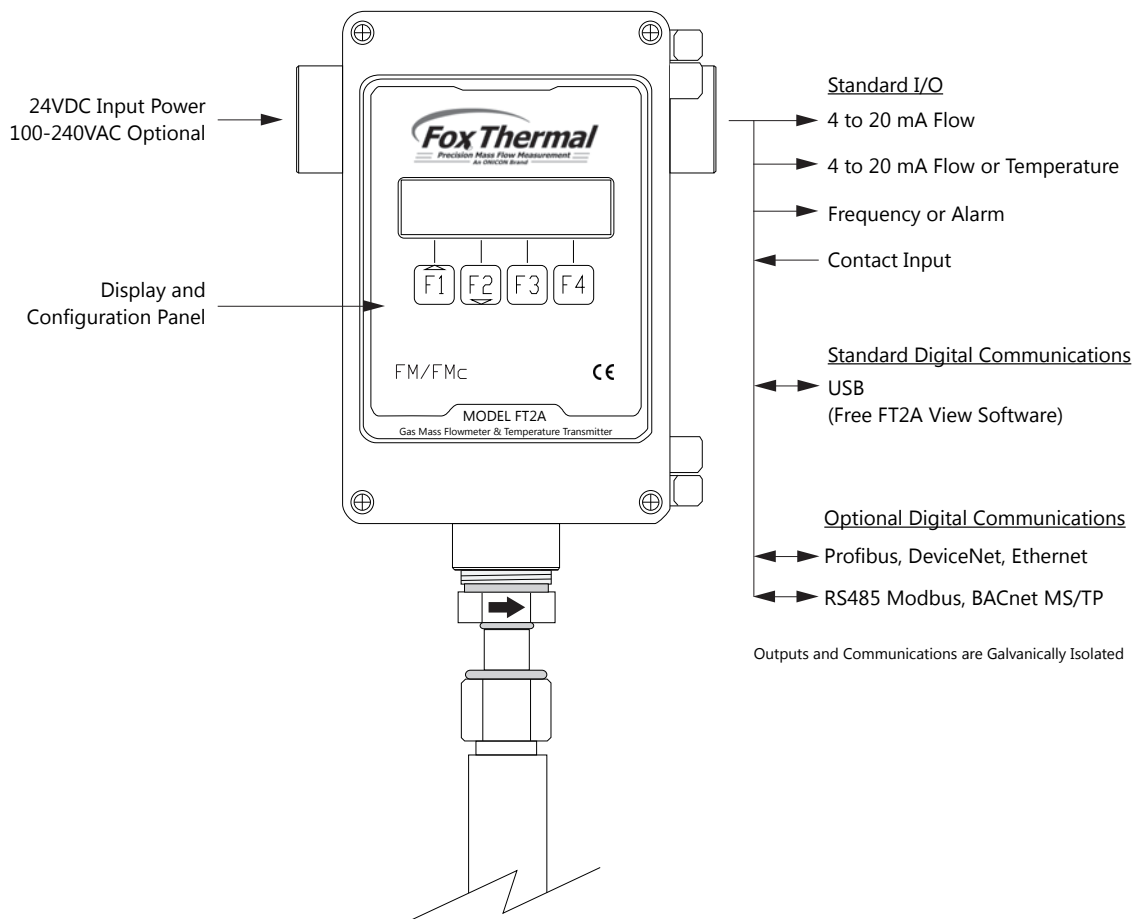

Installation

Scope

This section describes how to install the Fox Model FT2A Flow Meter and how to get started. Installation methods will vary according to the flow meter type (insertion or inline).

For Insertion Types:

1. Determine lateral position on the pipe
2. Sensor installation depth
3. Sensor orientation in relation to sensor length and direction of flow
4. Proper tightening of compression fitting for mounting meter

For Inline Types:

1. Determine lateral position on the pipe
2. Flow body orientation in relation to direction of flow in pipe
3. Proper tightening of compression fitting

Installation procedures must be performed using a combination of the end user's best engineering practices, in compliance with local codes, and manufacturer's recommendations.

General Precautions



The following general precautions should be observed:

1. Exercise care when handling the flow meter to avoid damaging the probe, sensor or enclosure.
2. Close any unused conduit openings in the enclosure with plugs certified for your application.
3. The enclosure covers must be closed except during installation.
4. Mounting FT2A in direct sunlight can cause the temperature inside the enclosure to increase beyond design limits, resulting in failure of LCD display and reduced component life. It is recommended that a sunshade be installed to avoid direct sunlight.
5. Ensure the flow direction arrow points in the direction of flow.
6. Do not install the FT2A enclosure near an igniter, igniter-controller or switching equipment.
7. Do not install an external power supply in a cabinet containing an igniter controller or switching equipment.
8. Ensure that good engineering practices and applicable industry codes are followed throughout the installation process.
9. For accurate flow measurement: review flow meter placement instructions before installation to ensure a proper flow profile in the pipe.

Installation

Instructions for Flow Meter Lateral Placement

Install the Model FT2A flow meter so that it is far enough away from bends in the pipe, obstructions, or changes in line sizes to ensure a consistent flow profile. See Fig. 2.1 below for your meter type.



NOTE! Pipe ID = Inside Diameter.

Fig. 2.1: Upstream and Downstream Pipe IDs for Flow Meters

INSTALLATION

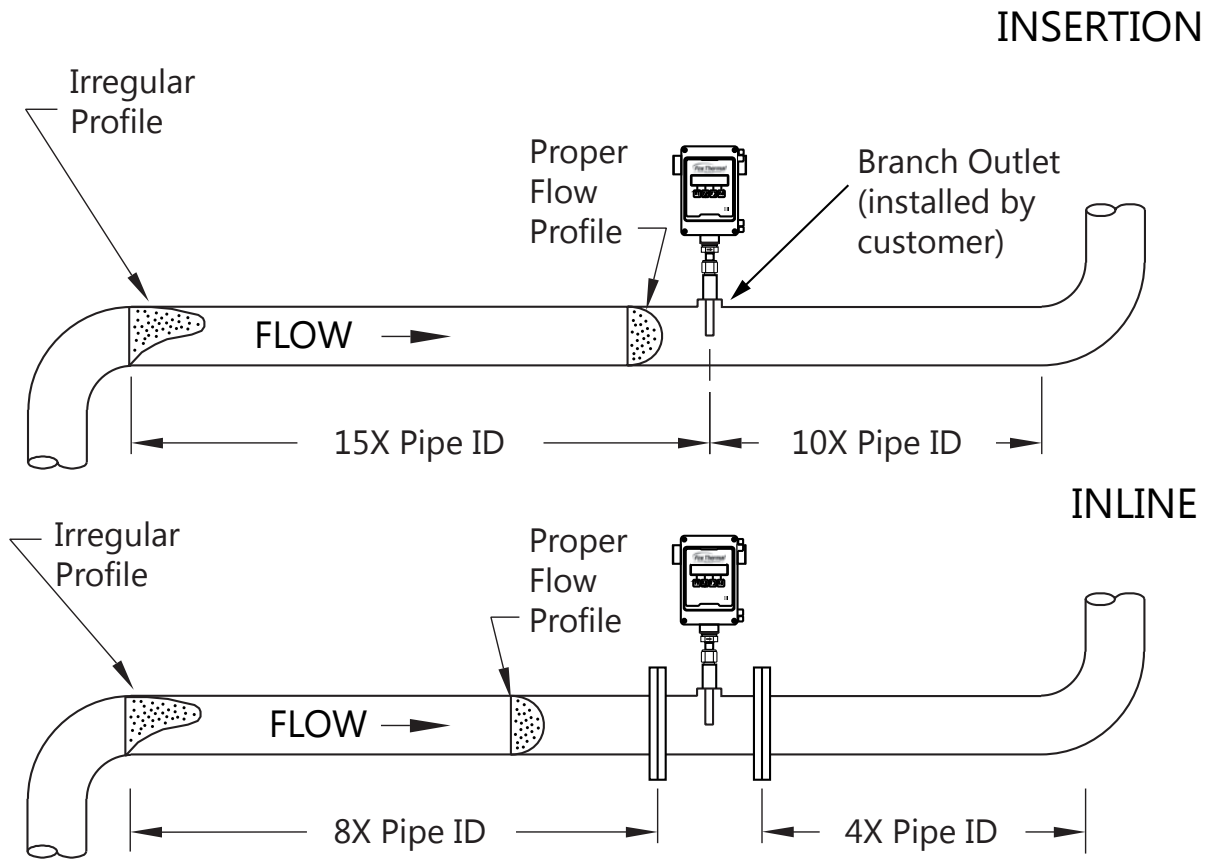

NOTE!

- The probe diameter is 1/2"
- An irregular flow profile will affect sensor accuracy

Installation

Welding NPT Female Fitting to Pipe

The probe of the FT2A must be installed perpendicular in the pipe to measure flow accurately. Use the following steps to ensure that the 1" NPT female fitting is correctly welded to the pipe. Directions:

1. Drill a 0.781-inch hole inside the fitting through the wall of the pipe (1 wall only).
2. Assemble the compression fitting and NPT fitting hand tight onto the probe of the FT2A.
3. Insert the probe into the hole in the pipe and use the FT2A probe and compression fitting to align the NPT fitting with the hole and the probe perpendicular to the pipe.
4. Tack-weld the NPT female fitting carefully onto the pipe.
 - Before welding the fitting completely, verify the probe is aligned to the center of the pipe and the hole is centered in the NPT fitting (see Figure 2.2).
5. To verify that the correct hole position has been achieved, carefully slide the 0.75-inch sensor in and out of the NPT female fitting and 0.781-inch hole.



WARNING! Do not force the 0.75-inch sensor through the 0.781-inch hole. Forcing it through the 0.781-inch hole can damage the probe!

6. Verify that the temporary weld of the NPT female fitting positions the probe window on the pipe's centerline.
 - Figure 2.2 shows an incorrect welding of the NPT female fitting, causing the 0.75-inch sensor to be "off center".
7. Once the NPT fitting is aligned properly, remove the 0.75-inch sensor from the NPT female fitting and finish welding. Then verify the probe is still aligned with the center of the pipe.
8. Set the depth of the flow meter (see "Fig. 2.3: Cross Section of Insertion Sensor Depth in Pipe" on page 21).
 - Do not tighten Swage fitting until proper depth of flow meter is determined. See Fig. 2.3.

Fig. 2.2: Alignment of NPT Female Fitting

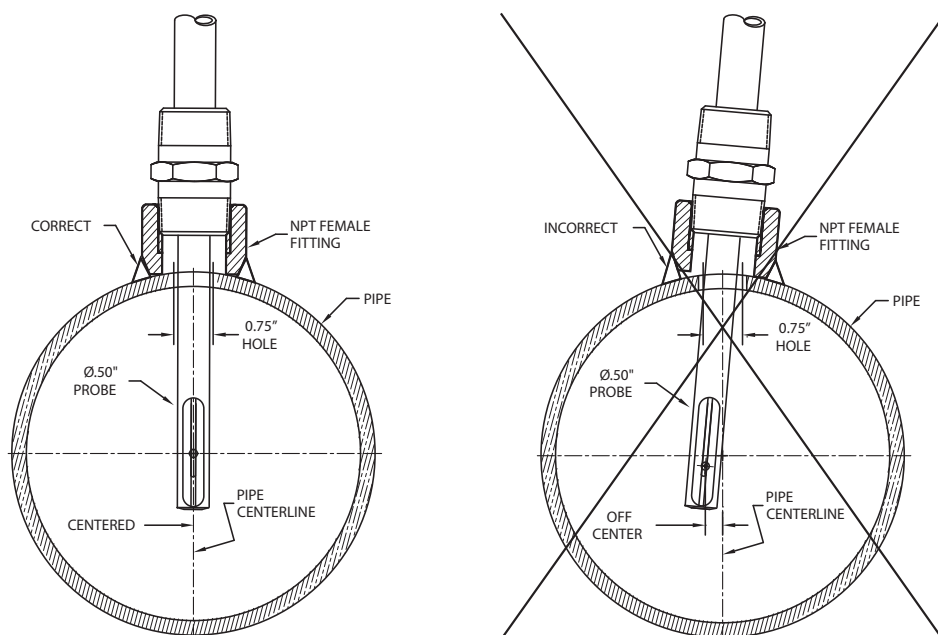

Installation

Installation Depth

The installation depth of the sensor in the pipe is dependent on the pipe size. To get the most accurate reading, proper placement of the sensor window within the pipe is necessary. As shown in Fig 2.2, the end of the sensor window should be 0.87" past the center line of the pipe.

Fig. 2.3: Cross Section of Insertion Sensor Depth in Pipe

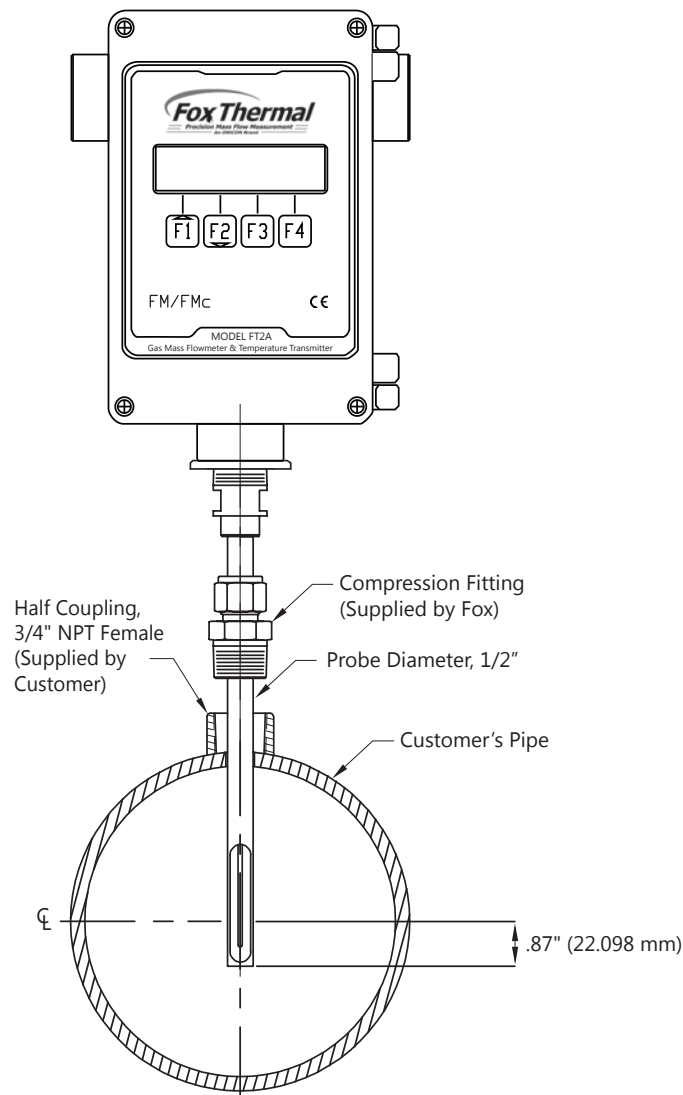

Specific Conditions of Use:

- The flameproof joints of the equipment are not intended to be repaired. Consult the manufacturer if dimensional information on the flameproof joints is necessary.
- The flamepaths of the equipment are not intended to be repaired. Consult the manufacturer if repair of the flamepath joints is necessary.
- Follow the manufacturer's instructions to reduce the potential of an electrostatic charging hazard.

Installation

Fig. 2.4: Orientation of Type Flow Meter

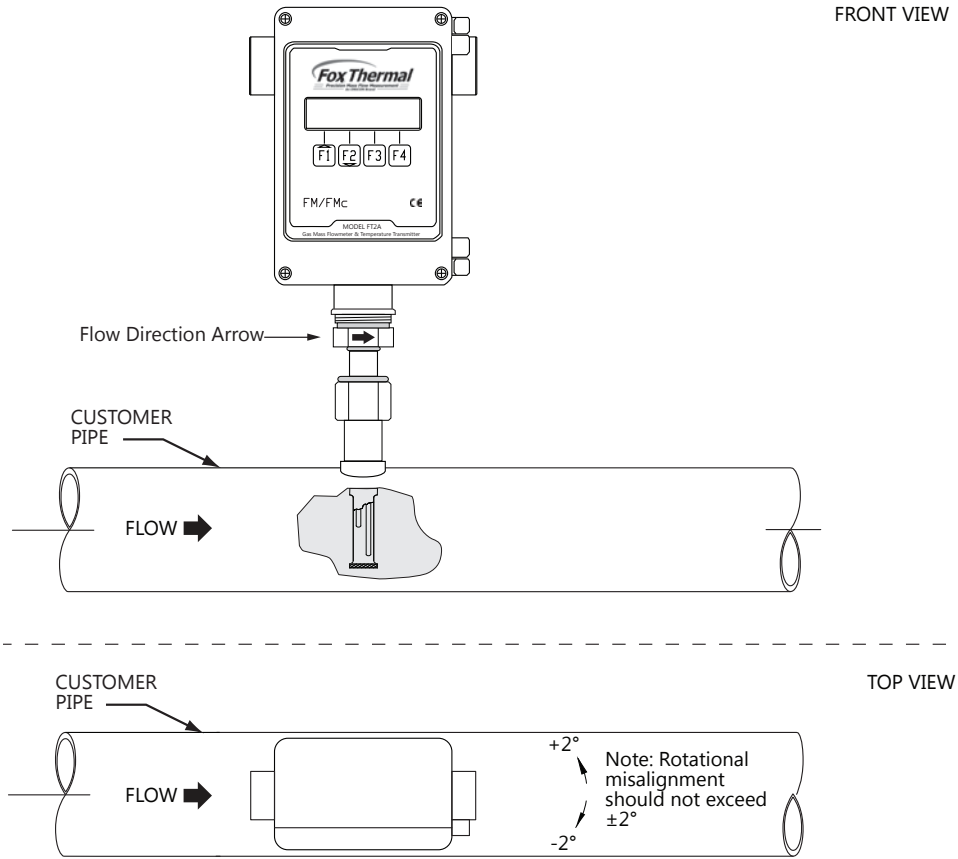

NOTE! Some flow meters are shipped with the sensor elements that are offset (see figure 2.4). Others are shipped with sensors that have equal length elements (see figure 2.5). The sensor type supplied was selected at the factory to be the best suited for your application. Follow the appropriate sensor orientation instructions.

Installation

Unequal Length Sensor Elements

Install the shorter sensor element upstream from the longer one.

Fig. 2.5: Unequal Length Sensor Elements

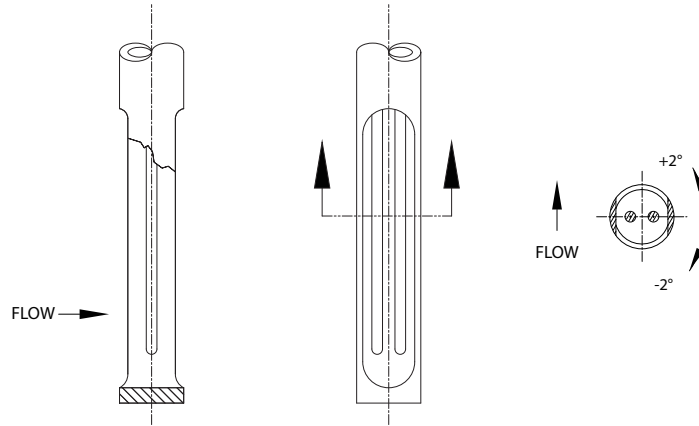

Equal Length Sensor Elements

Install flow meter with *both sensor elements* facing the flow stream within $\pm 2^\circ$.

Fig. 2.6: Equal Length Sensor Elements

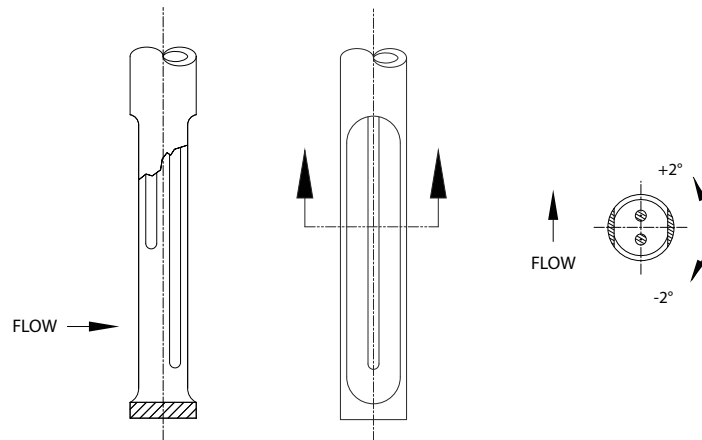

Installation

Mounting Instructions - Compression Fittings

The Model FT2A is mounted through a 7/8" hole and a 3/4" female NPT half coupling provided in the customer's pipe. Insertion style flow meters are not designed for use in pipes smaller than 1 1/2".

- Install the compression fitting into the 3/4-inch female NPT half coupling.
- When installing in a 2" pipe or larger, install the end of the probe 0.87" past the center line of the pipe and tighten the compression fitting nut (refer to figure 2.2 on p. 12).
- When installing into a 1 1/2" pipe carefully install the probe into the pipe until it touches the opposite wall and pull back 0.1". Tighten the compression fitting nut.
- While holding the fitting body steady, tighten the nut one and one-quarter turn to the 9 o'clock position. See Figure 2.6.



CAUTION! For a 1 1/2" pipe, do not tighten compression fitting without 0.2" distance from wall or damage to probe will occur.



CAUTION! Once the compression fitting ferrule is locked onto the probe, the probe can be removed or rotated, but the insertion depth is locked in place.



CAUTION! If the stainless steel or teflon ferrules are not properly tightened, and/or the recommended pressure is exceeded, the ferrules can slip on the stainless steel tubing causing damage to the meter or bodily harm.

Fig. 2.7: Proper Tightening of the Compression Fitting Nut

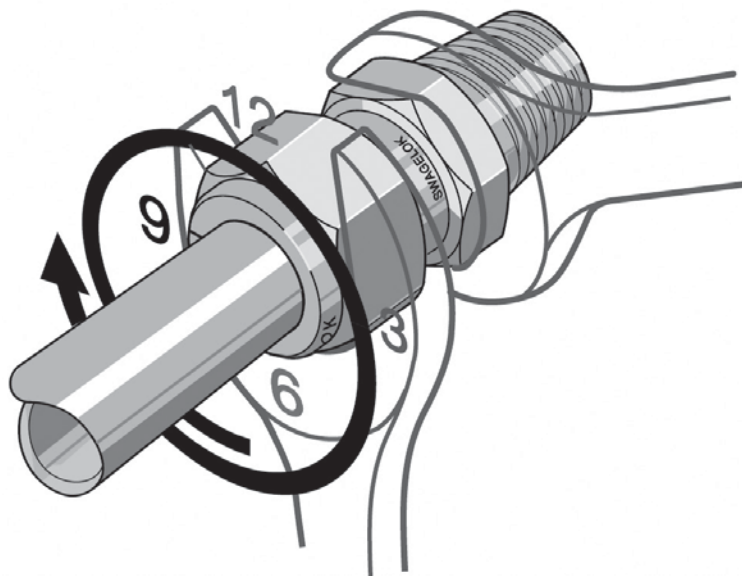

Installation

Installation of a New Retractor Assembly

1. Remove collar clamp from probe using a 3/16" Hex Key.
2. Remove meter probe from retractor assembly and leave the ball valve open. Keep the collar spacer on the probe so it is not misplaced.
3. Install the valve assembly on the pipe, by tightening the Hex Nipple with a 1 3/8" wrench.

Fig. 2.8: Retractor Assembly With and Without Probe Installed

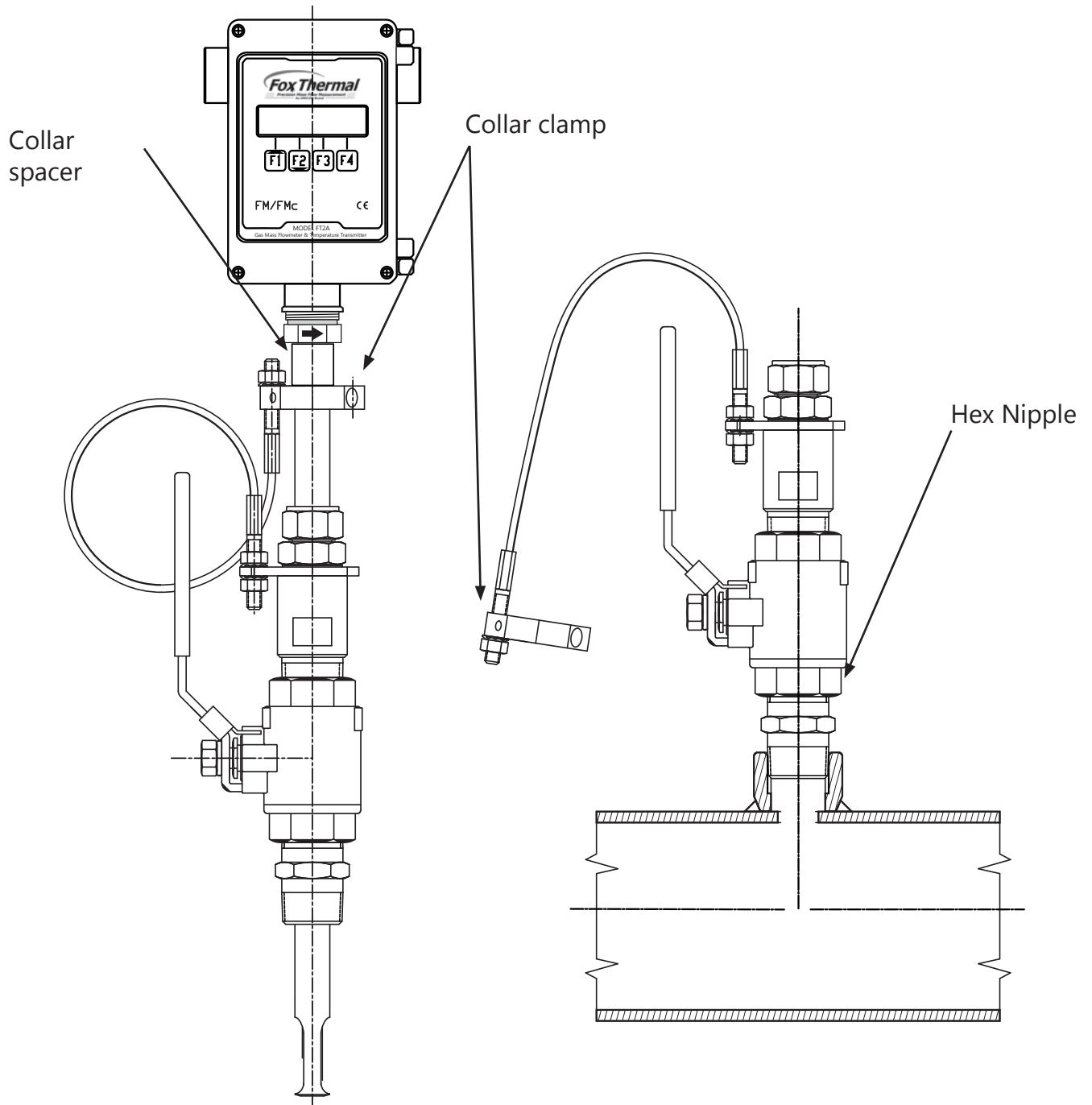

Installation

- Carefully slide the probe through the retractor assembly and through the hole to see if there is interference by touching the pipe wall with the end of the probe on the far side or until the probe cannot go deeper. Remove the probe. Remove the retractor and rework the hole, if required.

Fig. 2.9: Verify Probe Insertion

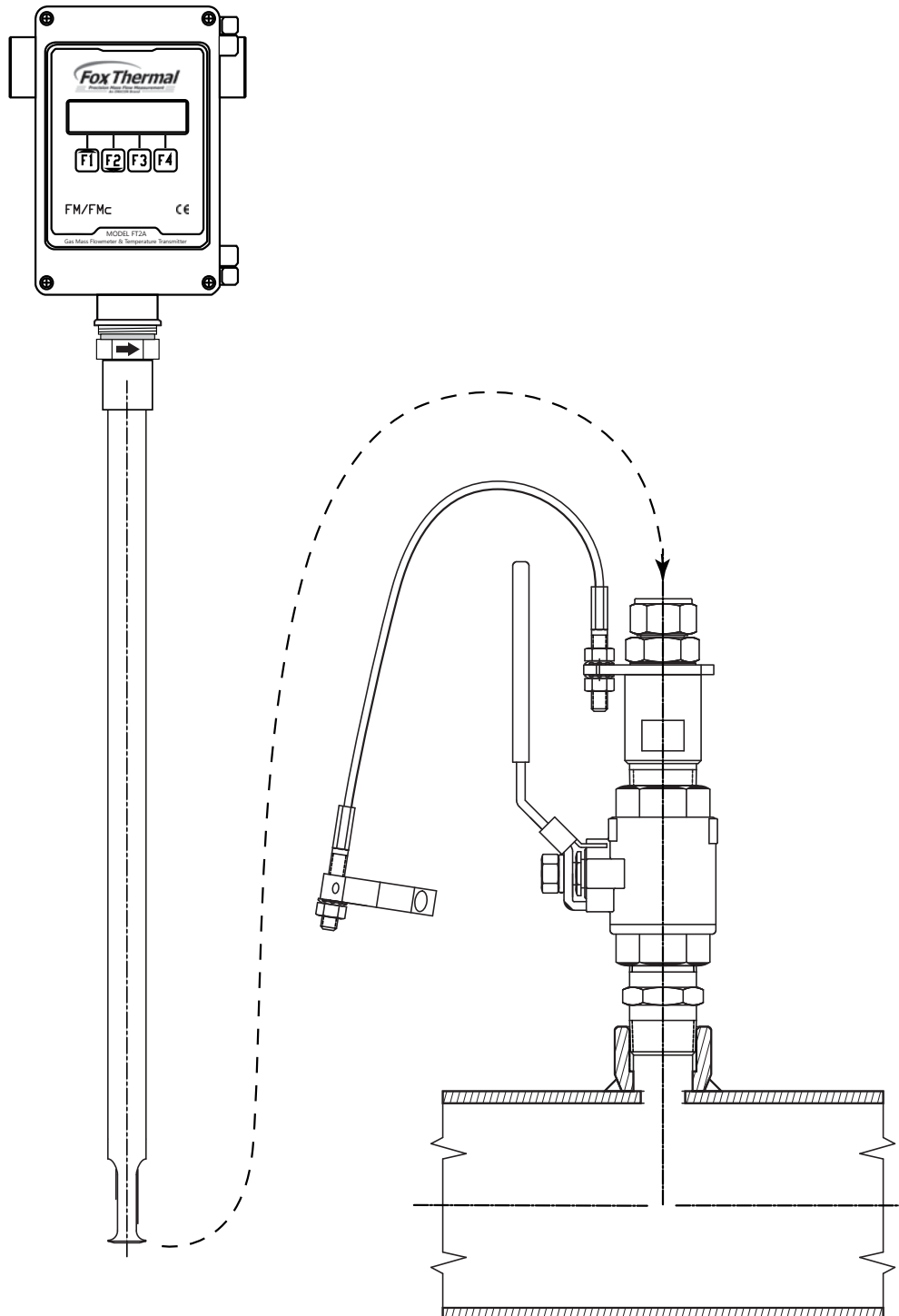

Installation

- Using the equation $(L + D/2 + 0.73")$ from Figure 2.9, calculate the insertion depth and mark on the probe while measuring from the end of the probe.
- The Retractor Clearance table of Figure 2.9 lists the space required to remove the meter from the retractor. Use the model code of your meter to determine the dimension.

Fig. 2.10: Determining and Marking Insertion Depth

RETRACTOR CLEARANCE	
CODE	"RC" DIMENSION
15R	23.9" [60.7 CM]
18R	26.5" [68.3 CM]
24R	32.5" [83.6 CM]
30R	38.5" [98.8 CM]
36R	44.5" [114.0 CM]

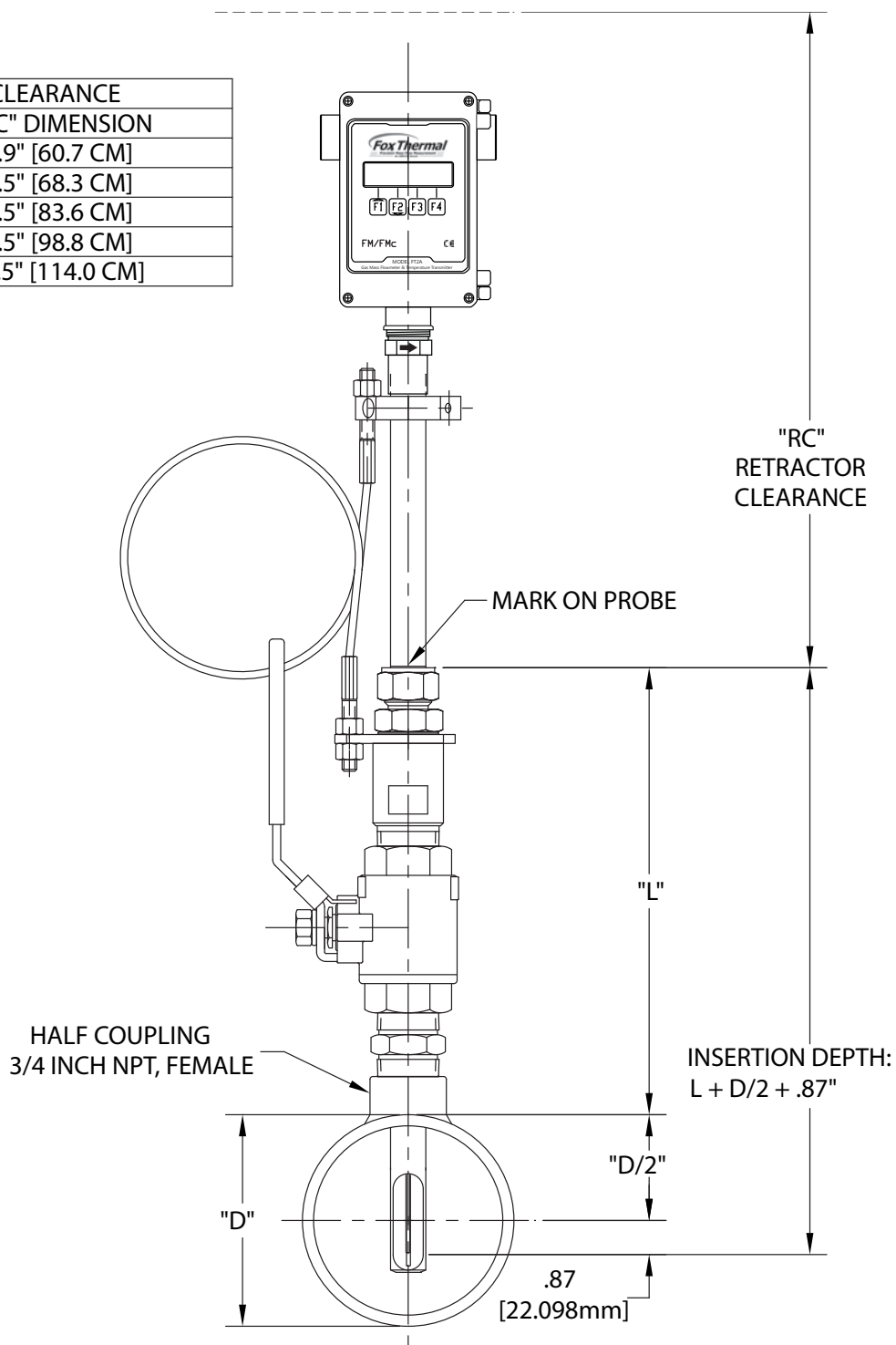

Installation

7. Insert probe back into the retractor to the depth mark and hand-tighten the compression fitting.
8. Verify that flow direction indicator is in line with pipe and in the direction of flow.

Fig. 2.11: Installed Retractor

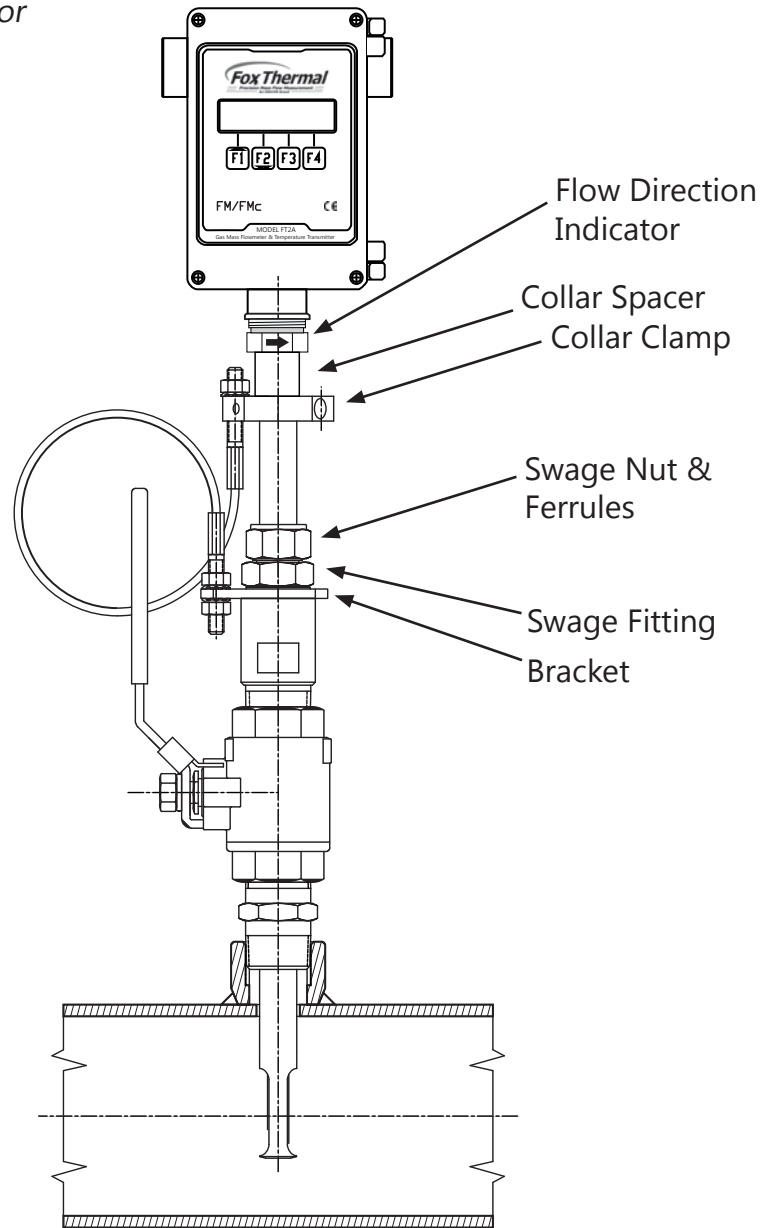

9. Fully tighten compression fitting (refer to "Mounting Instructions - Compression Fittings" on page 15).



Wiring

Wiring Instructions

Wire the FT2A by opening the enclosure cover, bringing customer supplied wires in through the conduit openings and connecting to the terminal blocks. The FT2A has two conduit openings to maintain separation between AC input power and output signal wiring. To eliminate the possibility of noise interference; use a separate conduit for AC power, cut all wires short for a minimum service loop and keep the wires within the area of the FT2A internal metal shields.

Wiring Precautions



- **WARNING - DO NOT OPEN THE ENCLOSURE WHEN ENERGIZED OR AN EXPLOSIVE ATMOSPHERE IS PRESENT.**
- All plumbing and electrical installations of flow meters must be in compliance with local codes, the end user's best engineering practices, and manufacturer's recommendations.
- An external power disconnect and 16A over-current protection are required for the AC and DC powered FT2A.
- Do not install the FT2A enclosure near an igniter, igniter-controller or switching equipment.
- Do not install an external power supply in a cabinet containing an igniter controller or switching equipment.
- This flow meter contains components that can be damaged by static electricity. You must discharge yourself by touching a grounded steel pipe or other grounded steel material prior to working inside this flow meter.
- For the remote sensor option, the serial number of the electronics enclosure must match the remote sensor probe.
- Close any unused conduit entries using suitably certified plugs
- *Installation wiring: Cut all wires short for a minimum service loop.* Obtain the correct length for the FT2A wires using one of these methods:
 - Trim the wires to extend 5 inches out of the enclosure after the conduit and wires are routed to the FT2A.
 - Trim the wires to extend 6 inches from the end of the conduit before attaching them to the FT2A.

Power Wiring

For power wiring, use stranded copper wire, no larger than 16-gauge. If an external 24VDC power source is used, twisted pair shielded cable is recommended. Supply connection wiring must be rated for at least 90°C.

Grounding

The enclosure must be properly grounded with a quality earth ground. 16 gauge, stranded wire is recommended.

Wiring



Signal Wiring

For signal wiring, the recommended wire gauge is 18 to 22 AWG. Always use twisted pair shielded cable. The cable shield should not be connected at the flow meter, it should be connected at the power supply AC ground terminal or instrumentation AC ground. Do not route the AC power and signal wires in the same conduit. AC power wires must enter left-hand conduit entry.

Serial Communication Wiring

If you have purchased communications options, please refer to one of the following appropriate Fox Instructions Manuals:

- Fox FT2A Modbus / BACnet MS/TP Manual
- Fox FT2A Profibus, DeviceNet, Ethernet Manual

Remote Sensor Wiring



NOTE! Remote wiring is only required when the Remote Electronics option is provided.

Five wire shielded cable required, the recommended wire gauge is 18 AWG. Run the shielded cable through a separate grounded steel conduit to the bottom conduit opening of the electronics enclosure (no other cables or wires in the conduit). If you are using your own cable, make sure that the cable length does not exceed 100 feet and the wire resistance does not exceed one ohm. Do not connect the cable shield at the electronics enclosure end.

Fig. 3.1: FT2A Wiring

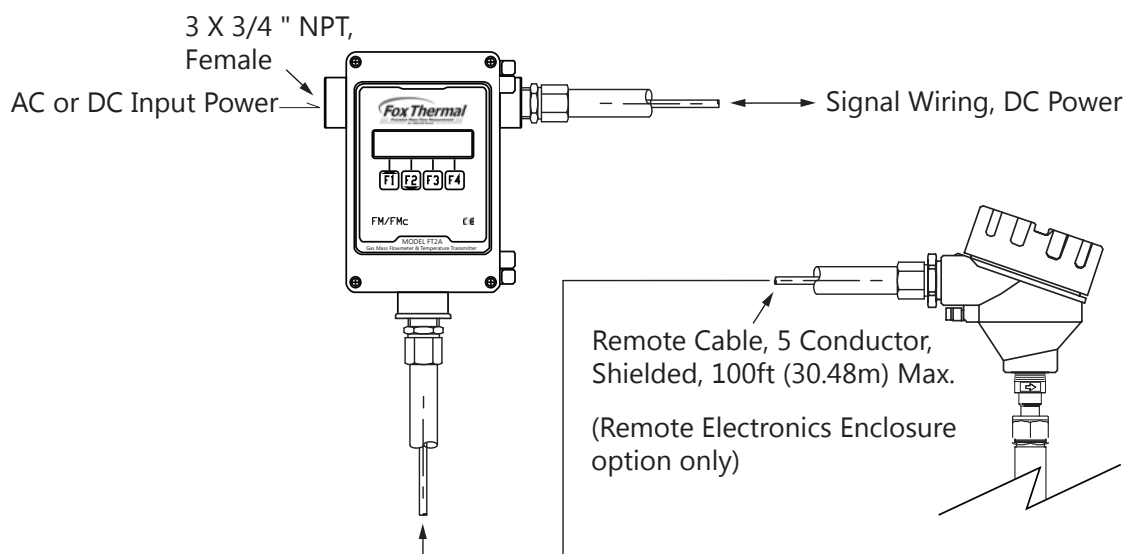

Wiring

FT2A Internal Components

Fig. 3.2: Internal Components for Wiring the FT2A

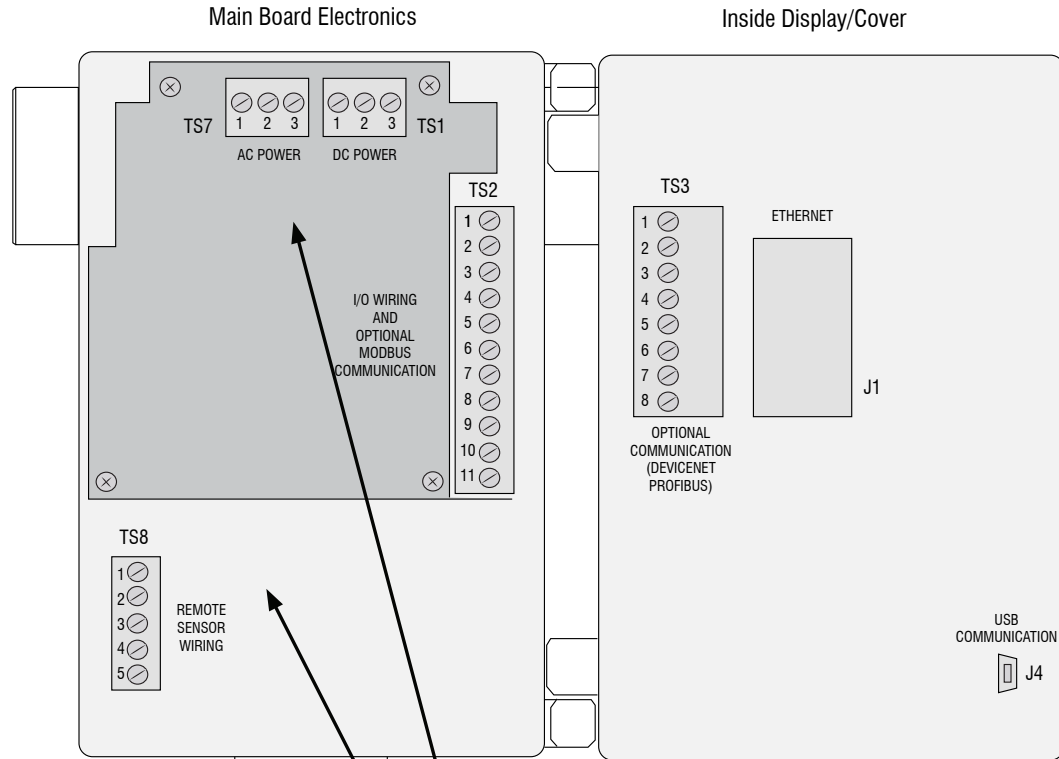

Keep power and signal wires within the area of the metal shields.

Keep power and signal wires out of the unshielded area.



NOTE!

Serial numbers: If you have more than one meter, you must ensure that the serial numbers of the probe/J-Box, remote electronics, housing, and/or flow body match one another. These items have been manufactured and calibrated to operate as a unit and cannot be mismatched.

WIRING

Wiring



Power Input Requirements: 24VDC Supply

External DC power supply must provide 24VDC \pm 10%, at 0.7 Amps minimum.

The enclosure must be properly grounded with a quality earth ground. Sixteen (16) gauge, stranded wire, is recommended for power and earth ground.

Fig. 3.3: Connections for 24VDC Supply

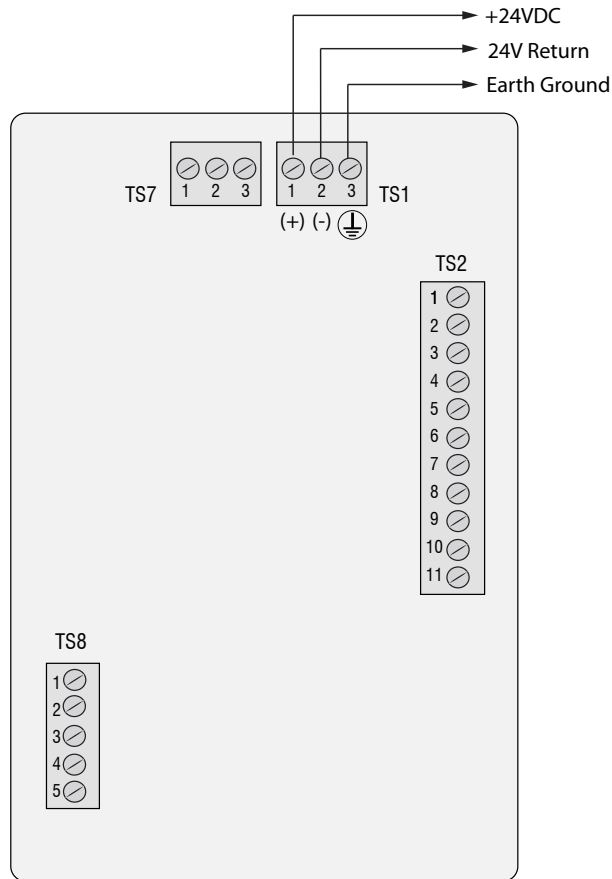

CAUTION!

- Supply connection wiring must be rated for at least 90°C.



Wiring

Power Input Requirements: 100 to 240VAC Supply

If the FT2A has the AC power supply option, the AC power must provide 100 to 240VAC -15% / +10% (85 to 264VAC) at 0.2 Amps minimum.

The enclosure must be properly grounded with a quality earth ground. Sixteen (16) gauge, stranded wire, is recommended for power and earth ground.

Fig. 3.4: Connections for optional AC Power

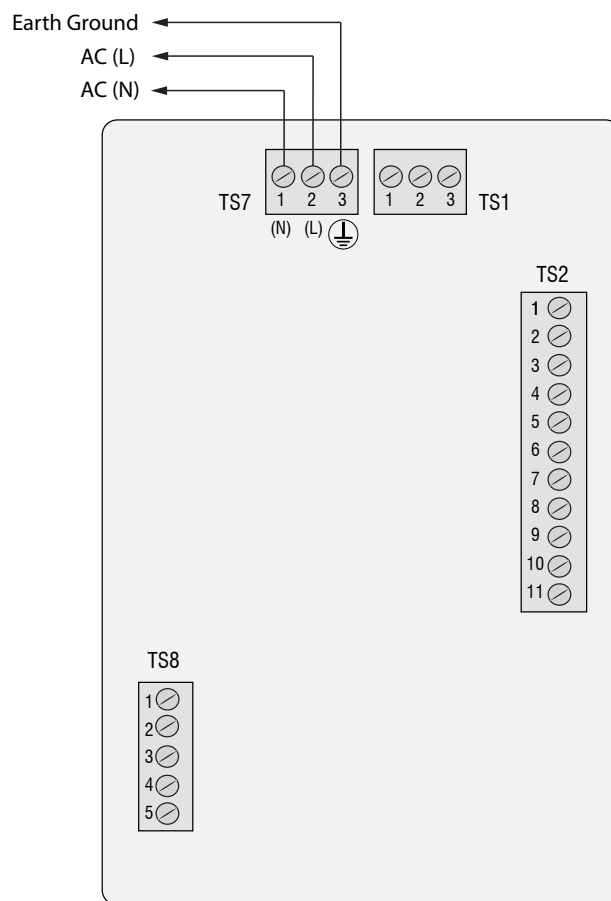

CAUTION!

- Supply connection wiring must be rated for at least 90°C.

Wiring



4-20mA Output Wiring: Customer-Supplied Power Source

Bring the 4-20mA wiring in through the right-hand conduit hub. Connect FLOW RATE 4-20mA wiring to TS2 pin 1(+) and 2(-). Connect 4-20mA output #2 wiring to TS2 pin 3(+) and 4(-).

Fig. 3.5: 4-20mA Output Wiring for Customer-Supplied Power Source

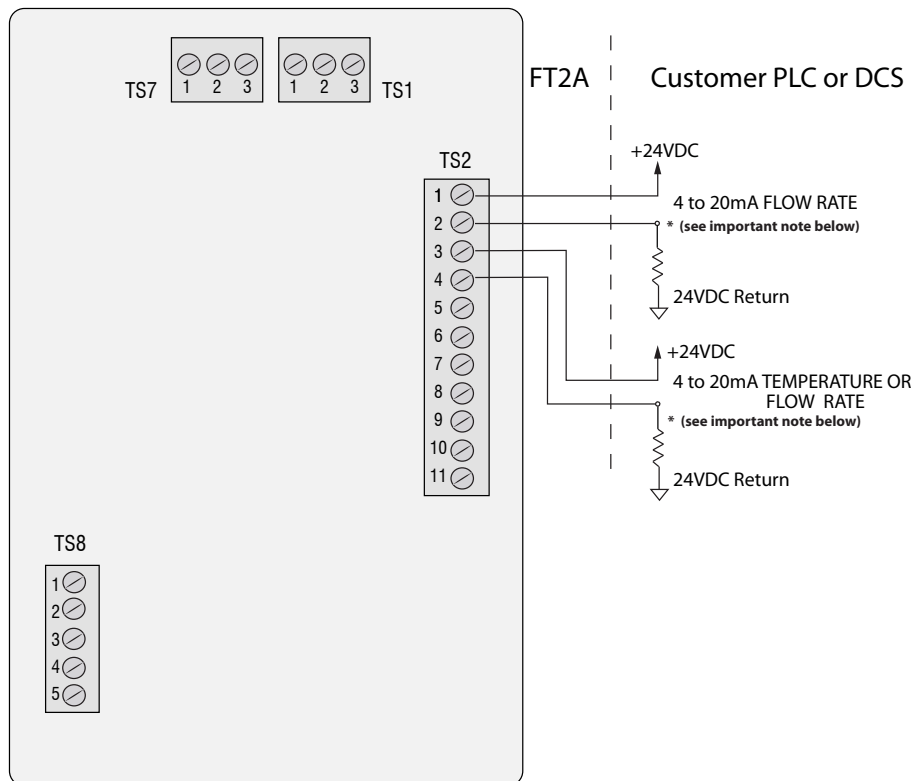

WIRING



Important Note

The load resistor on the Fox Flow Meter 4-20mA signal is typically 250 ohms and is located in or at the customers PLC or DCS. A 250 ohm resistor in the 4-20mA line will result in a 1 to 5VDC signal to the PLC or DCS. Some PLC/DCS equipment has the load resistor built in to the unit; please refer to the PLC/DCS technical manual. **Do not exceed a 600 ohm load on the Fox Flow Meter 4-20mA signal.**



4-20mA Output Wiring: Loop Power Provided by FT2A

Bring the 4-20mA wiring in through the right-hand conduit hub. Connect the 4-20mA wiring to terminal blocks TS1 and TS2 as shown in the diagram below.

Fig. 3.6: 4-20mA Output Wiring for Loop Power Provided by FT2A

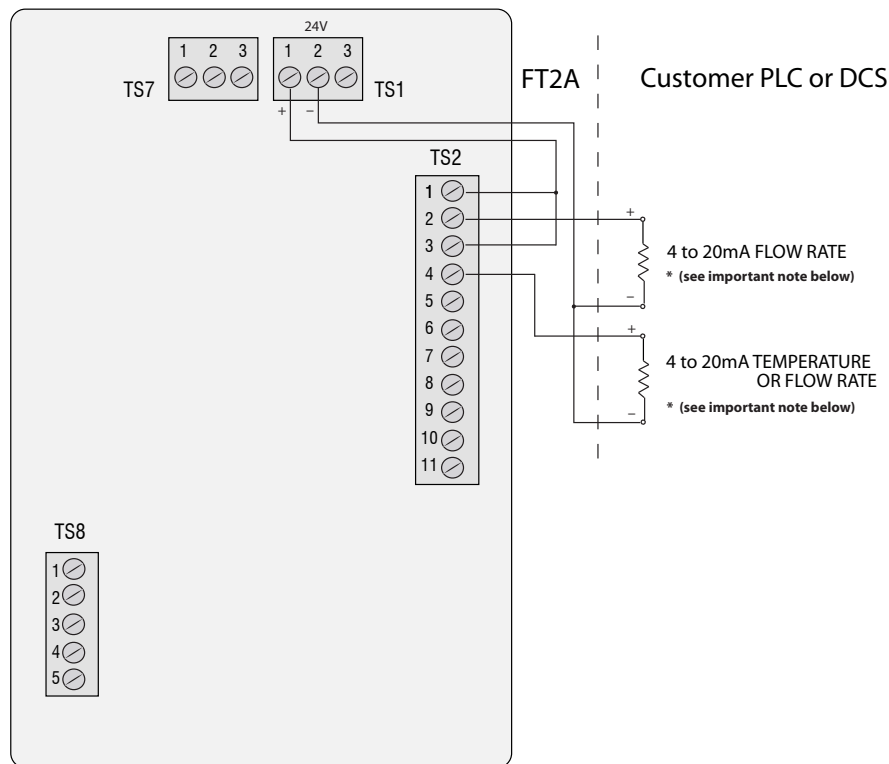

Important NOTE!

The load resistor on the Fox Flow Meter 4-20mA signal is typically 250 ohms and is located in or at the customers PLC or DCS. A 250 ohm resistor in the 4-20mA line will result in a 1 to 5VDC signal to the PLC or DCS. Some PLC/DCS equipment has the load resistor built in to the unit; please refer to the PLC/DCS technical manual. **Do not exceed a 600 ohm load on the Fox Flow Meter 4-20mA signal.**



Wiring

Setting Up the NE-43 Alarms

The FT2A flow meter supports the NAMUR specification NE-43 for alarms on the 4-20mA output. See p. 40 for the 4-20mA output NAMUR operation.

CAUTION! Configure the FT2A with the following setup when using the 4-20mA output to control equipment in a failsafe application.

4-20mA Failsafe Wiring: NAMUR NE-43

When the 4-20mA output is used to control equipment in failsafe applications:
 Wire the 4-20mA output in series with the Alarm output as shown in Figure 3.7
 Configure the Pulse/Alarm output to Alarm and select System Alarm as shown in the "Alarm Output" on p. 40.

The System Alarm output is designed to allow current to flow during normal operation and interrupts current when power to the meter is lost or in a System Alarm condition.

In the 4-20mA Failsafe Wiring configuration of Fig. 3.7, the 4-20mA signal goes to 0mA if power to the FT2A is lost or a System Alarm occurs.

Fig. 3.7: 4-20mA Failsafe Wiring and Range of 4-20mA Output for NAMUR Alarm

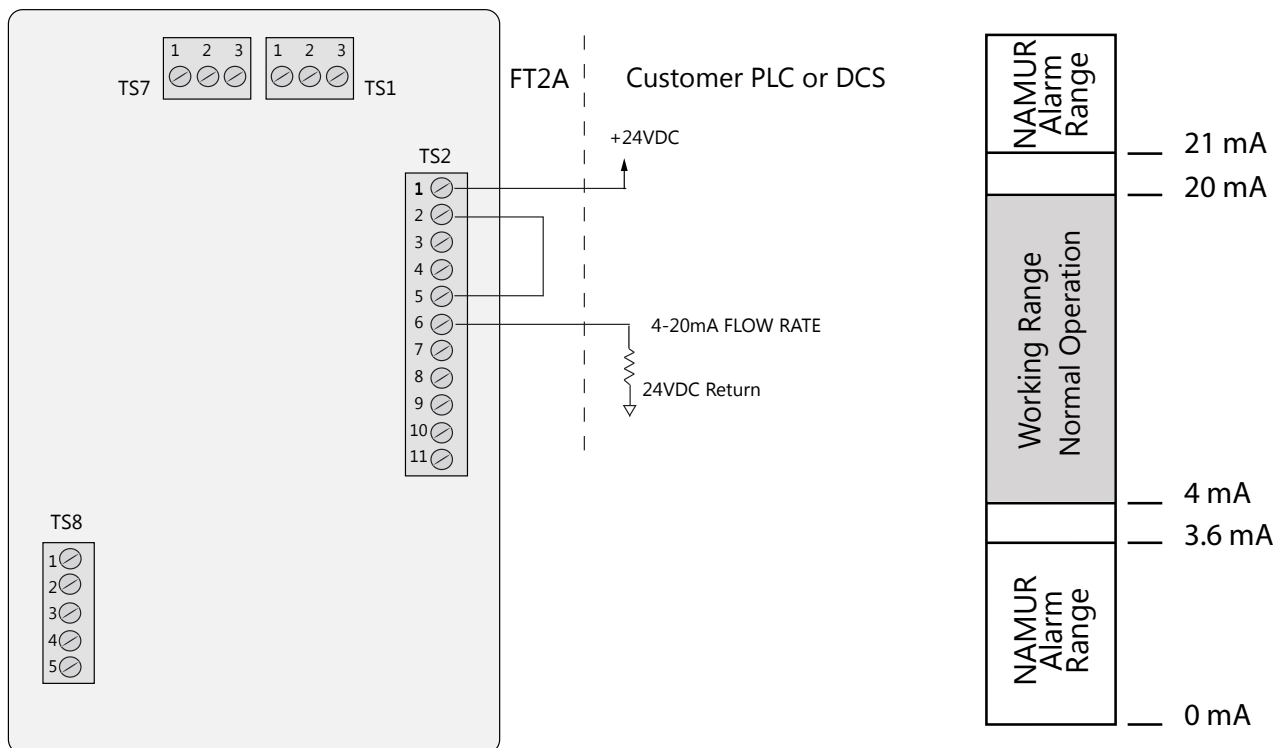



Wiring

Frequency/Alarm Output Wiring

Bring frequency/alarm wiring in through the right-hand conduit hub. Connect to TS2 pin 5(+) and 6(-). The frequency/alarm output is an open collector circuit capable of sinking a maximum of 20mA of current. Frequency or alarm selection is programmed using the display or FT2A View™. Only one option, frequency or alarm, can be active at a time.

Fig. 3.7: Frequency/Alarm Output Isolated (Recommended)

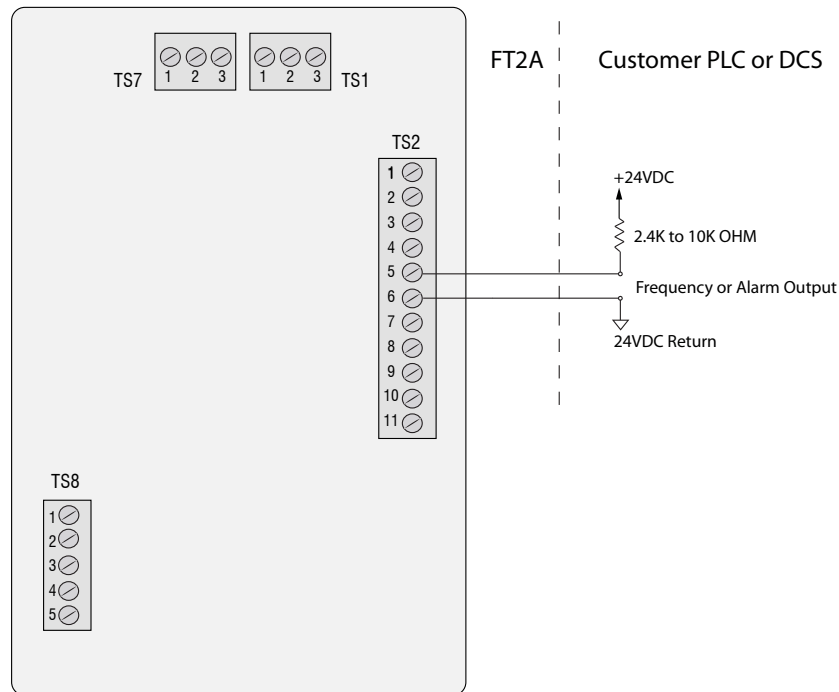
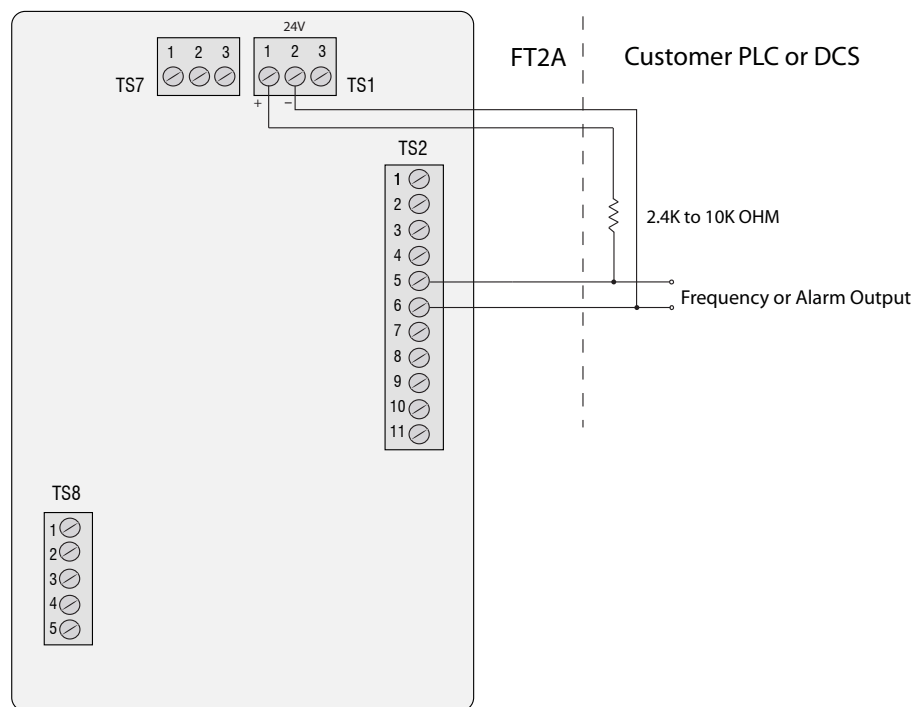

Fig. 3.8: Frequency/Alarm Output Local +24V Power Option



WIRING

Wiring



NOTE!

The FT2A Frequency/Alarm output is typically used to drive digital circuitry or solid-state relays. The output of a solid state relay may, in turn, operate loads such as electromechanical relays or alarm indicators.

Remote Switch Wiring

A remote switch can be used to reset the Totalizer and elapsed time, if enabled in the programming settings. There is no polarity requirement on these connections. Use TS2 pin 10(+) and 11(-).

When the 2 gas curve option is ordered, the switch can be used to switch between curves.

Fig. 3.9: Remote Switch Wiring

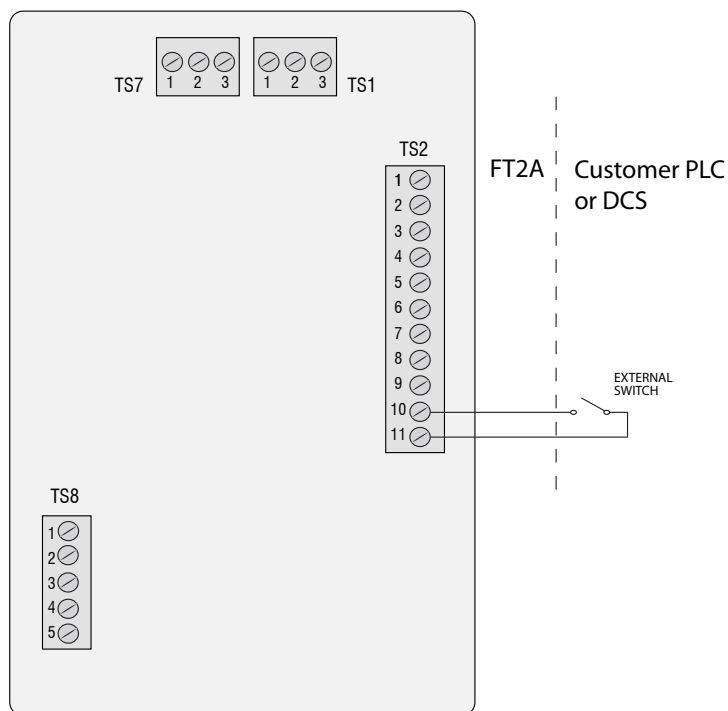



Wiring

Remote Wiring

Remote wiring is the same for both insertion and inline type FT2A flow meters.



NOTE! Remote wiring is only required when the Remote Electronics option is provided.

Five wire 18 AWG shielded cable required. Run the cable through a separate grounded steel conduit (no other cables or wires in the conduit). Make sure that the cable length does not exceed 100 feet and the wire resistance does not exceed one ohm.

Do not connect the cable shield at the electronics enclosure end.

The extension cable connects the terminals of the remote probe enclosure to connector TS8 of the electronics enclosure as shown in Figure 3.11 and Table 3.1 (p. 31).

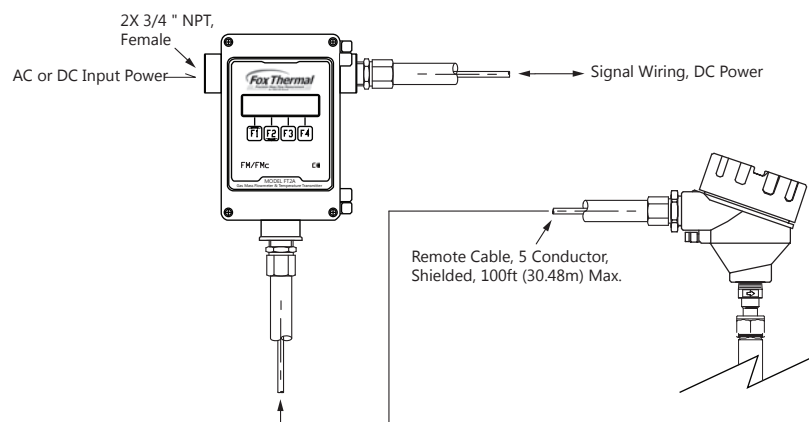

Installation wiring: Keep the wires inside the FT2A enclosure short. Obtain the correct length for the FT2A remote wires using one of these methods:

- Trim the wires to extend 5 inches out of the enclosure after the conduit and wires are routed to the FT2A.
- Trim the wires to extend 6 inches from the end of the conduit before it is attached to the FT2A

Wiring



Fig. 3.11: Remote Sensor Wiring

WIRING

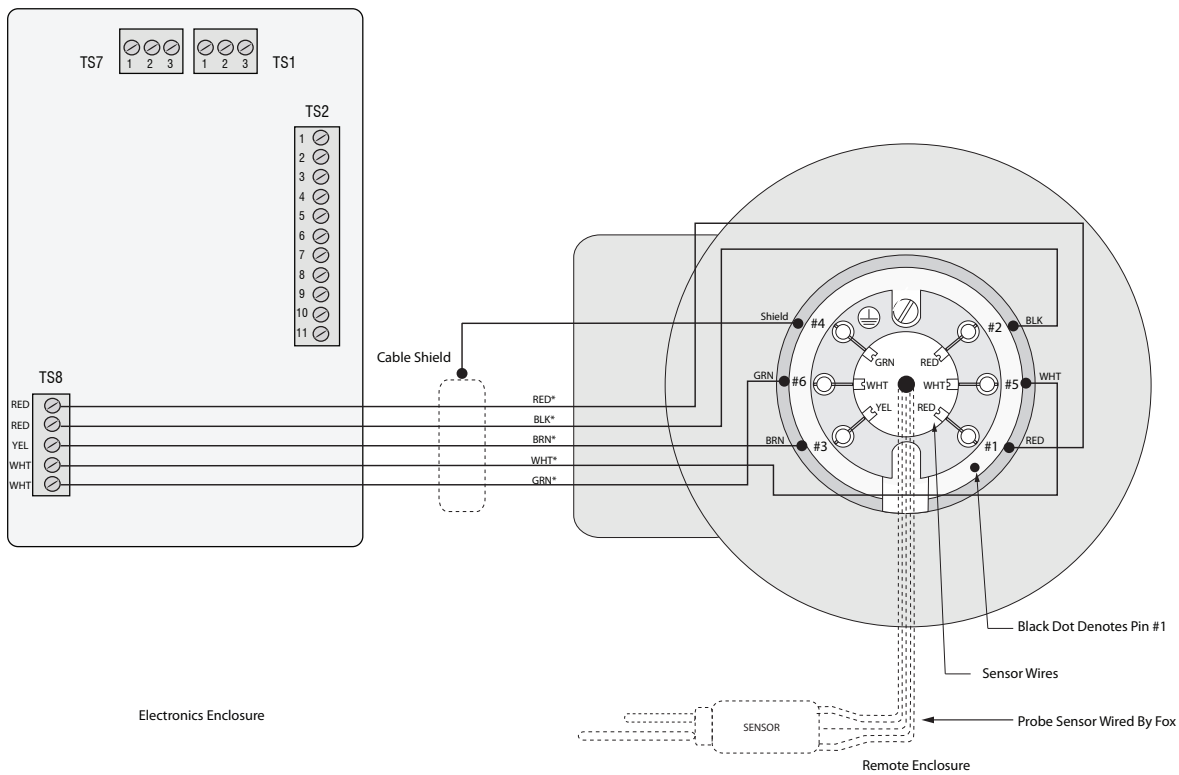

***Wire colors listed here represent the wire colors of cables supplied by Fox. Colors may vary if customer is supplying their own cable.**

Table 3.1: Remote Sensor Cable Wiring

Electronics Enclosure Terminal Numbers	Extension Cable Wire Color	Remote Enclosure Terminal Numbers	Sensor Wire Color
1	Red	1	Red
2	Black	2	Red
3	Brown	3	Yellow
No Connection	Shield	4	Green
4	White	5	White
5	Green	6	White

Operation

Start Up Sequence

The program automatically enters the Run/Measure mode after power up. The screen will show the software version of the FT2A during power up.

USB Interface

The USB interface is a standard feature which allows communication with a PC to monitor readings and configure settings. FT2A View™, is a free application program from Fox that connects to the USB interface and allows data monitoring, configuration setting, data logging to Excel, and an option to save and recall FT2A configuration data. A serial communication manual is available for users who want to create their own PC application.

FT2A Display Panel & Configuration Panel

The FT2A display is a 2 line x 16 character display with 4 mechanical buttons. The meter can be programmed by using the display and configuration panel.



NOTE! Fox also offers FT2A View™, a Windows-based PC program, that can be used to program the meter.

Fig. 4.1: FT2A Display and Configuration Panel

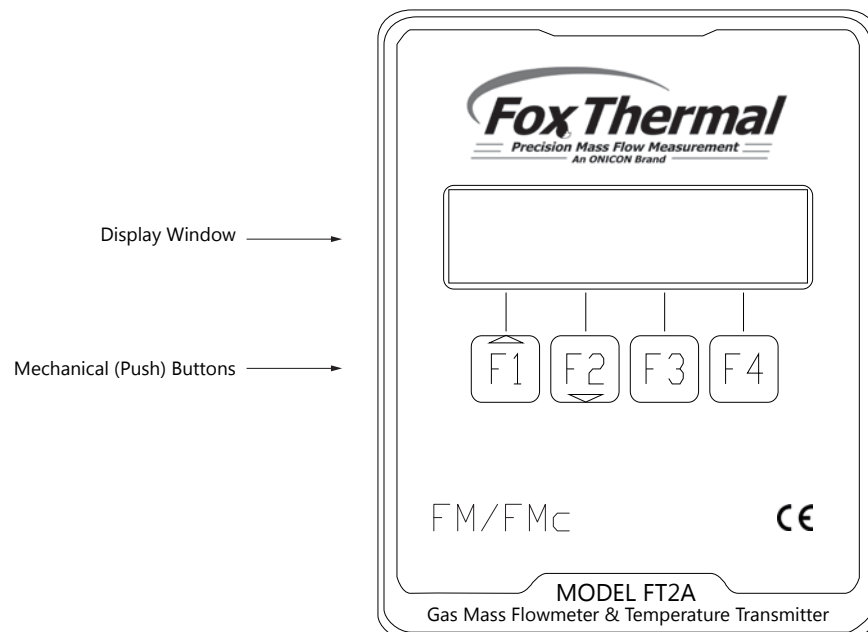

Operation

Measurement Mode

In the measurement mode, there are four different display screens (display 1, 2, 3 and a prompt screen to enter the programming mode). Two display screens are user programmable (refer to Display Setup p. 41). Scrolling through the display is accomplished by pressing the F1 or F2 key to view the next or previous screen. Pressing the F1 and F2 keys at the same time enters the Engineering Menu screens (display 10 through 26). Keys F1 and F2 are used to scroll through the different screens and key F4 is used to exit to Display #1. Pressing the F3 and F4 keys at the same time enters the Reset Total screen (see p. 50).

Fig. 4.2: FT2A Display Screen Navigation

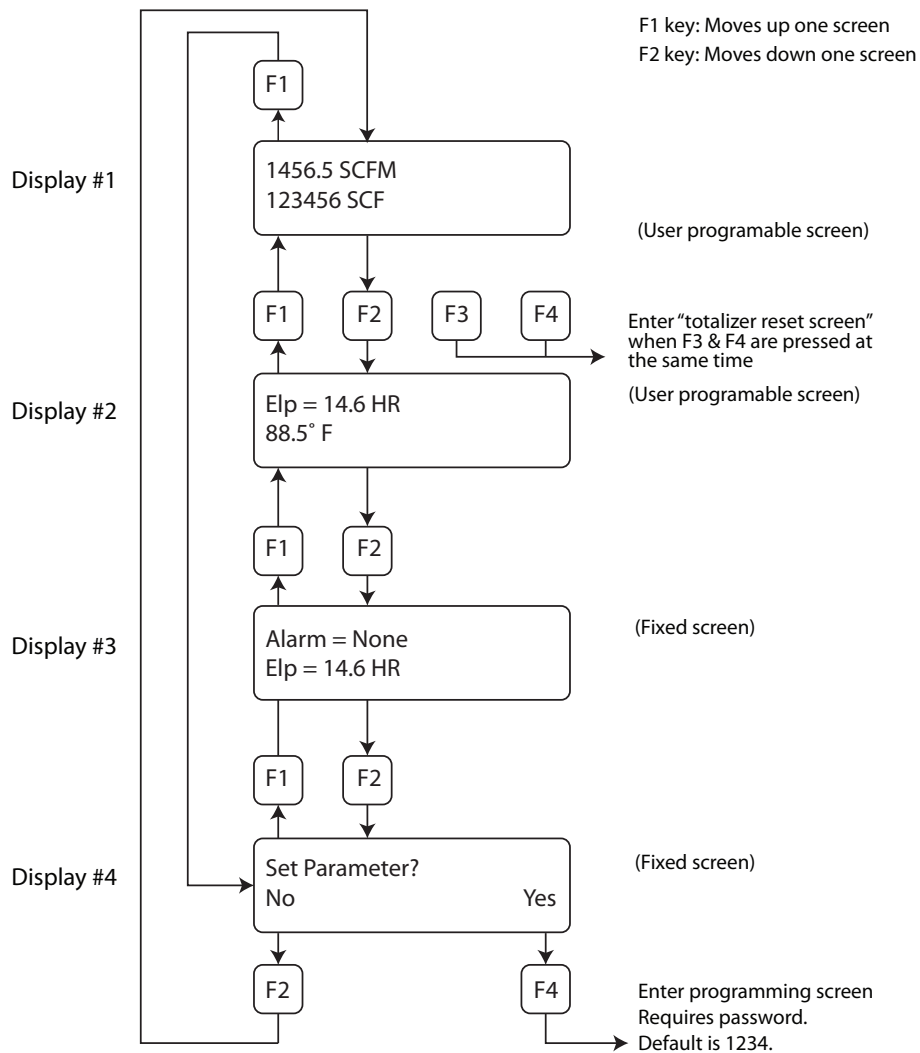

Operation: Engineering Displays

FT2A Engineering Displays

Pressing the F1 & F2 keys at the same time in the normal mode, brings up the engineering displays. These displays show internal parameters of the FT2A which are used by Fox service technicians.

Use the F1 & F2 keys to navigate. Press F4 to exit.

Fig. 4.3: FT2A Engineering Displays

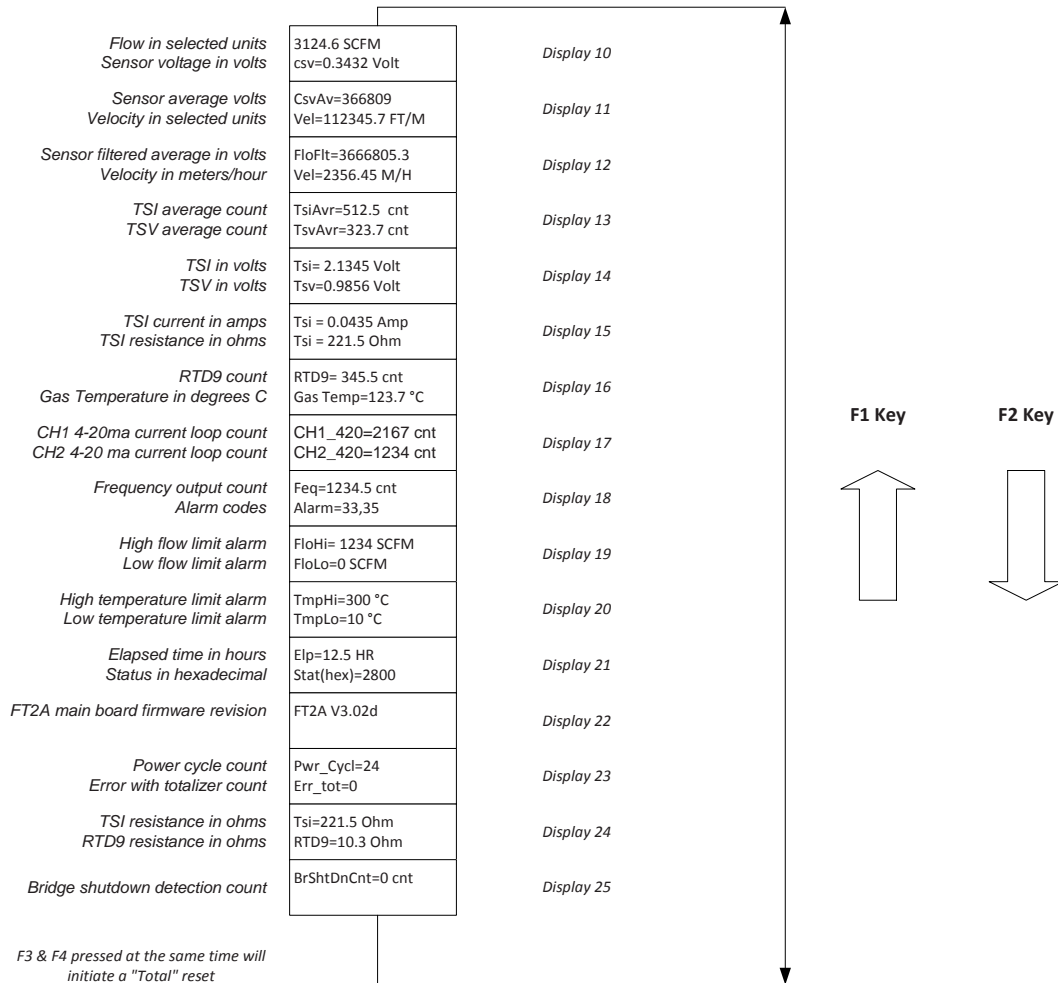

Operation

Data Entry using the local display module

There are 2 basic types of menu entries: one for changing value or string and one for selecting from a selection list.

To Change a Value or String :

VALUE = 0.91234		OK	
CHG			

F1 F2 F3 F4

Press **CHG (F1)** key to change the value, **OK (F4)** to accept the value.

VALUE = 0.91234			
UP	DN	NXT	OK

F1 F2 F3 F4

Press the **UP (F1)** or **DN (F2)** key to select a new digit or character, the cursor points to the selected digit. Press **NXT (F3)** to select the next digit and **OK (F4)** to accept the entry.

To Select from a List:

FLO UNT = SCFM		OK	
NXT			

F1 F2 F3 F4

Press **NXT (F1)** key repeatedly until the correct selection is made and **OK (F4)** key to accept the entry.

Entering the Programming Mode

To enter the programming mode, press the **F1** or **F2** key repeatedly in the normal running mode until the following screen is shown:

SET PARAMETERS ?			
No		Yes	

F1 F2 F3 F4

Press **YES (F4)** and the following screen will prompt user to enter password:

PASWD:_			
UP	DN	NXT	OK

F1 F2 F3 F4

Operation

Enter the correct password, then follow the instructions for changing a value as specified on page p. 35. The default Level 1 password is "1234".

If the wrong password is entered, the message "Wrong Password" will display and then return to the programming entry screen.

If the password is accepted, the base programming screen will be shown:

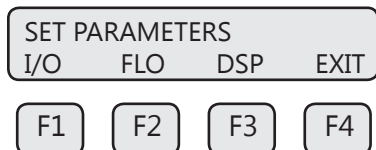

This is the base screen for the programming mode. Press **EXIT (F4)** repeatedly until "Normal Mode" is seen briefly to exit the programming mode.

Analog 4-20mA Output

The following menu allows the scaling of the analog 4-20mA output. From the Main Menu, press **I/O (F1)** to move to the 4-20mA output selection. In this screen press **420 (F3)** (screen appearance may vary according to options).

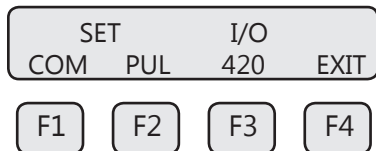

The 4-20mA output is programmable for flow or temperature:

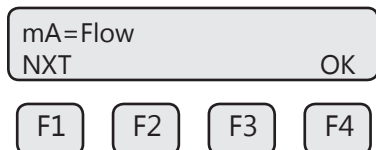

Selections for the 4-20mA output are:

- Flow
- Temp

Select **NXT (F1)** to select Flow or Temperature and then press **OK (F4)**.

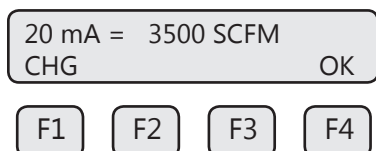

Enter the value for the 20mA and press **OK (F4)** key to accept the setting. Then the following screen will display:

Operation



NOTE! When the flow rate exceeds the programmed value for the 20mA set point, the analog output will stay at 20mA and an alarm code will be generated.

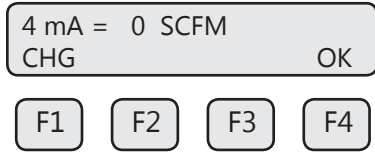

Enter the value for the 4mA and press **OK (F4)**.



NOTE! 4mA is normally set to 0.

The following menu item allows the user to select an alarm level on the 4-20mA output when a serious issue is detected that is preventing the calculation of a correct flow value.

The options are:

- Force the 4-20mA signal to 3.6mA
- Force the 4-20mA signal to 21mA
- Do not force the 4-20mA signal (not used)

CAUTION! When using the 4-20mA output equipment in a failsafe application, use the wiring configuration on p. 27 and set the Pulse/Alarm Output to System Alarm as shown in "Alarm Output" on p. 40.

After setting the 4mA output value, choose the mA fault value:

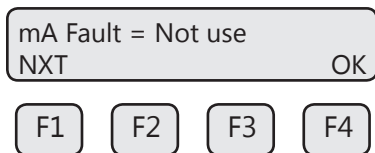

The following events will set the output to 3.6mA or 21mA if the alarm level is selected:

- Sensor resistance above high limit
- Bridge Shutdown

When the 4-20mA output is wired through the System Alarm, the following cause the output to go to 0mA:

- Power to the Microprocessor is lost
- Sensor or electronics failure

Fig. 4.3: Range of 4-20mA Output and NAMUR Alarm

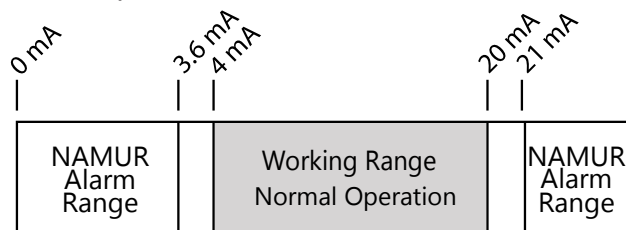

Operation

Press **(F4)** repeatedly until "Normal Mode" is seen briefly to exit the programming mode.



NOTE! When the flow rate exceeds the programmed value for the 20mA set point, the analog output will stay at 20mA and an alarm code will be generated.

Frequency Output

From the main menu, press **I/O (F1)**, **I/O (F2)** and then **OUT (F2)**.

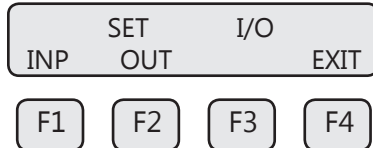

Press **OUT (F2)** to select output.
The following screen may show:

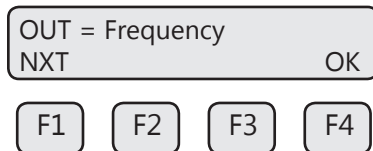

Press **NEXT (F1)** to cycle through output options until you have the selection for "OUT=Frequency" and press **OK (F4)**.

The frequency output can be configured in one of three ways:

(1) specifying a maximum frequency to a defined maximum value of flow rate, (2) specifying how many flow units total per pulse, U/P (i.e., 0.1 SCF per pulse) or (3) specifying how many pulses per unit, P/U (i.e., 10 pulses per SCF). All of these approaches are equivalent.

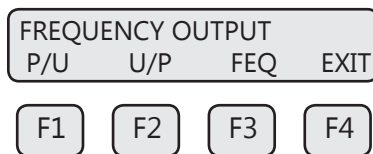

Use **P/U (F1)** to enter pulse per unit, **U/P (F2)** for Unit per pulse or **FEQ (F3)** to enter the flow and maximum frequency to scale the frequency output.



NOTE! When data is entered with any of the three described methods, the other values will be re-calculated according to the settings.

Operation

Entering data in Pulse per Unit:

From the Frequency Output Menu above, press **P/U (F1)** and the following screen will show:

PLS/UNT = 1.2		OK	
CHG			
F1	F2	F3	F4

Press **CHG (F1)** to change the setting and then **OK (F4)** to accept entry.

The value entered is in pulse per selected flow unit total (i.e., 10 pulses per SCF).

Entering data in Unit per Pulse:

From the Frequency Output Menu on p. 38, press **U/P (F2)** and the following screen will show:

UNT/PLS = 0.01		OK	
CHG			
F1	F2	F3	F4

Press **CHG (F1)** to change the setting and then **OK (F4)** to accept entry.

The value entered is in unit per pulse (i.e. 0.01 flow unit total per pulse)

Entering data with flow and maximum frequency:

From the Frequency Output Menu on p. 38, press **FEQ (F3)** and the following screen will show:

MaxFreq=98.5 Hz		OK	
CHG			
F1	F2	F3	F4

Enter the maximum frequency and press **OK (F4)**.
(Maximum frequency should not exceed 100 Hz)

The next screen will show:

MaxFlo=4999.8 SCFM		OK	
CHG			
F1	F2	F3	F4



NOTE! When the flow rate exceeds the maximum frequency set point, the output will stay at that maximum frequency but the FT2A will issue an alarm code.

CAUTION! Equation to ensure pulse rate must not exceed 100 Hz.

Operation

Alarm Output

To program the Alarm output, press **I/O (F1)** key from the "SET PARAMETERS" menu screen, then select **I/O (F2)** and the screen will show:

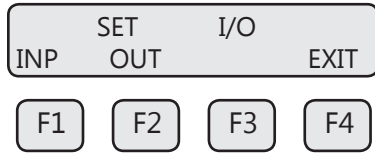

Then press **OUT (F2)** and the screen may show:



Then press **NXT (F1)** to select the correct alarm and press **OK (F4)**.

Selections are:

- HiFloAlm = High Flow Alarm
- LoFloAlm = Low Flow Alarm
- HiTempAlm = High Temperature Alarm
- LoTempAlm = Low Temperature Alarm
- System Alm= System Alarm
- Not used
- Frequency

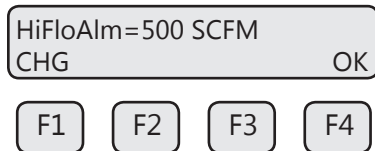

Enter the value for the limit by pressing **CHG (F1)** and then **OK (F4)**.



NOTE! There is only one output to operate as a frequency output or an alarm output. Both cannot operate at the same time.

For Discrete Input Settings:

From the main menu, press **I/O (F1)** and then **I/O (F2)** and then **INP (F1)** key to select input. The following menu will display:

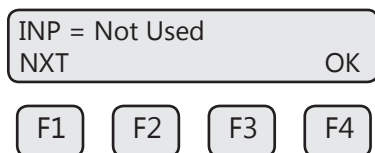

Press **NXT (F1)** repeatedly until the correct selection is shown and then press **OK (F4)** to accept the setting.

Operation

Selections are:

Not used

Tot Reset

Switch Crv

ordered)

Reset the totalizer

Switch between calibration curve 1 and curve 2 (only if 2 gas curve ordered)

Press **EXIT (F4)** repeatedly until you exit programming mode.

Serial Communication Settings

To program the Serial communication settings, press **I/O (F1)** key from the base menu.

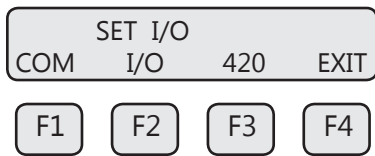

Press **COM (F1)** to select Serial communication:

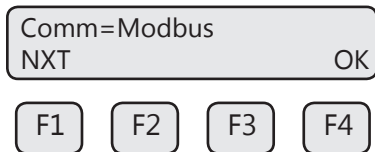

Options for serial communication are:

None

MODBUS

BACNET

PROFIBUS

DEVICENET

ETHERNET



NOTE! Any selection other than "None" requires the communication option for the selected communication type. If enabling a communication option, see the associated Fox Communication Manual for specific programming information: FT2A Modbus & BACnet MS/TP manual or FT2A Profibus, DeviceNet & Ethernet Manual.

Display Setup

Remember, there are four display screens that you can cycle through in normal operating mode (see Figure 4.2 on p. 33). Two of the four display screens are fixed and cannot be changed (displays #3 & 4). The other two screens are programmable to show the information that you prefer and is discussed in this section.

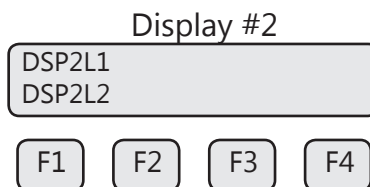
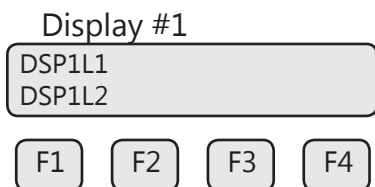

Operation

Selections are:

DSP1L1	Display 1, Line 1
DSP1L2	Display 1, Line 2
DSP2L1	Display 2, Line 1
DSP2L2	Display 2, Line 2

To Program Display Screens #1 & 2:

From the base programming menu press **DSP (F3)** to select the display menu:

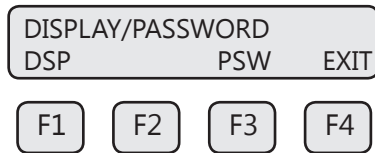

Press **DSP (F1)** key. The display will show:

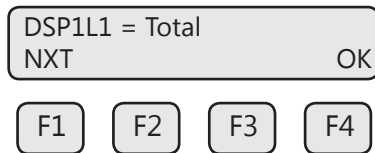

These are the selections for the display #1 line #1.

Selections are:

Flo rate	Flow rate
Total	Total mass
Elps	Elapsed time
Temp	Temperature
Alarm	Error codes

When the selection is correct, press **OK (F4)** to accept. The display will then go through the same process for all 4 lines of the 2 programmable displays (DSP1L1, DSP1L2, DSP2L1 and DSP2L2).

After the last line of display 2 is accepted, the display will show the following menu:

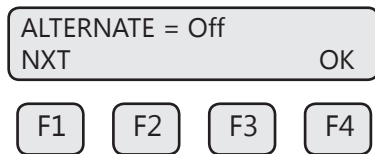

This menu allows you to alternate between menu display 1 and 2 every few seconds.

Selections are: On or Off

Press **OK (F4)** to accept selection.

Press **EXIT (F4)** repeatedly until "Normal Mode" is seen briefly to exit the programming mode.

Operation

Password

There are two user level passwords, only **Level 1** is programmable and gives access to all the normal settings. The second password is used to allow access to calibration factors and should normally never be changed unless advised by the Fox service department, or to set a new password in the event that the user forgets the **Level 1** password.

Default **Level 1** password is "1234", and **Level 2** password is "9111".

The **Level 1** programmable password can be disabled by setting it to "0".

From the base programming menu press **DSP (F3)** to select the display menu:

To Program the Password:

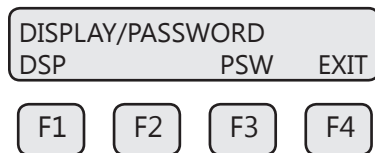

Press **PSW (F3)** key to select password.

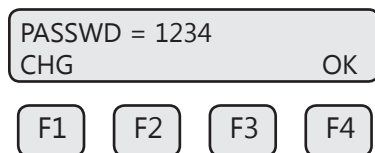

This screen displays the current **Level 1** password.

Press **CHG (F1)** key to change the password and enter new value (see p. 35 for further details).

Press **OK (F4)** to accept new data and exit programming by pressing **EXIT (F4)** key repeatedly until out of the programming mode.



NOTE! Password can be number or letter characters up to 4 digits.

Operation

Units Settings

This menu is used to set the units for mass flow, temperature, pressure reference and the settings of reference temperature, reference pressure and density of gas when using Lbs/time or Kg/time.

These values will be set at Fox, using the Application Data Sheet values. If the customer changes the application, these values can be changed to match the new application. Check with Fox customer service before changing the application gas.

The unit setting is accessed from the base programming menu.

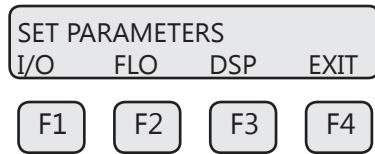

Press **FLO (F2)**:

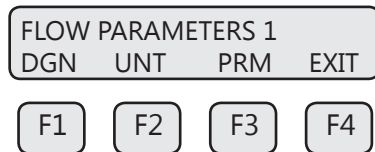

Press **UNT (F2)** for Unit selection.

The screen will show:

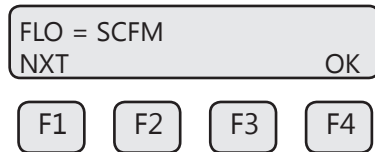

Press **NXT (F1)** to change selection and **OK (F4)** to accept.



NOTE! The totalizer (total flow measured) will roll over when reaching a certain value. The maximum value is dependent on the flow units selected.

Maximum Total Rollover Value:

Most flow units:	99,999,999,999
MSCFD:	999,999,999
MMSCFM:	9,999,999
MMSCFD:	999,999

Operation

Selections for flow units are:

SCFM	LBS/H	SFPM	MT/H
SCFH	LBS/M	MMSCFD (MMCFD)	NM3/D
NM3/H	LBS/S	LBS/D	MMSCFM (MMCFM)
NM3/M	NLPH	SLPM	SCFD
KG/H	NLPM	NLPS	MCFD (MSCFD)
KG/M	SMPS	MSCFD (MCFD)	SM3/M
KG/S	NMPS	SM3/H	SM3/D



WARNING! The FT2A re-calculates area, 4 and 20mA values, maximum flow for the frequency output and zero flow cutoff when changing flow units except for velocity units. When going to or from velocity units, the FT2A will not recalculate these values and these values must be re-entered manually.

After pressing **OK (F4)** to accept the Flow unit the display will prompt for the temperature unit setting:

TMP UNT= Deg F
NXT OK

F1

F2

F3

F4

Press **NXT (F1)** to change selection and **OK (F4)** to accept.

Selections for Temperature units are:

- Deg C
- Deg F

After pressing **OK (F4)** to accept the temperature unit setting, the display will prompt for temperature reference in selected unit.

TmpRef = 60 °F
CHG OK

F1

F2

F3

F4

Press **CHG (F1)** to change the reference and **OK (F4)** to accept.

After pressing **OK (F4)** to accept the reference temperature, the display will prompt for the pressure unit selection:

PRES UNT= Psia
NXT OK

F1

F2

F3

F4

Operation

Press **NXT (F1)** to select next entry and **OK (F4)** to accept.

Selections are:

- mmHG Millimeters of mercury
- Psia Pounds per square inch atmosphere
- bara Bar atmosphere

After the pressure unit selection is made, the display will show a menu to enter the pressure reference:

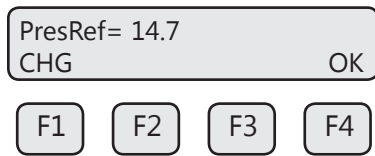

Press **CHG (F1)** to change it and **OK (F4)** to accept.

After the pressure reference is accepted, the display will prompt for the gas density if LBS or KG was selected for flow unit:

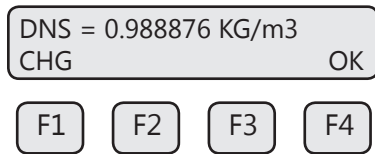

Press **CHG (F1)** to change and **OK (F4)** to accept.



NOTE! The density entry is only used when KG/time or LBS/time is selected for flow rate units.

Density conditions are referenced to 0 C° at 760 mmHg.

Flow Parameters

This is the menu used to set various flow parameter values. They are:
Flow cutoff, pipe area, filter, high and low alarm for flow and temperature.

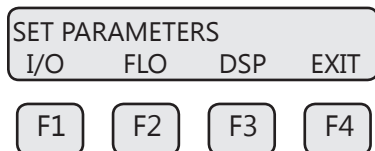

Operation

The menu is accessed from the base programming menu by pressing **FLO (F2)**:

FLOW PARAMETER 1			
DGN	UNT	PRM	EXIT
F1	F2	F3	F4

Then press **PRM (F3)**:

FLOW PARAMETER 2			
CAL	SPC	PRM	EXIT
F1	F2	F3	F4



NOTE! The CAL and SPC function keys will only appear and be accessible from a **Level 2** password.

Flow Cutoff

Then press **PRM (F3)**. The first parameter is Flow Cutoff:

CUTOFF = 2.0 SCFM		OK	
CHG			
F1	F2	F3	F4

Enter the value for the percent low flow cutoff and then press **OK (F4)**.

When the flow rate falls below the zero flow cutoff, the flow meter will display a flow value of zero.

Pipe Area

To set the Pipe Area:

A ² = 0.05672 Ft ²		OK	
CHG			
F1	F2	F3	F4

Enter the pipe area in **square meters** or **square feet** and then press **OK (F4)**.

Use square meters for metric flow unit selections and square feet for English flow unit selections.

Operation

Filter Value

The Filter Value is also referred to as a dampening factor and is used to quiet the readings. The filter value is an exponential filter that dampens the noise and is used as follows:

$$\text{Flow Value} = (\text{FA} * \text{new value}) + (\text{FB} * \text{average})$$

Where FA = filter value, FA + FB is equal to 1.0.

A lower filter value will increase dampening of the flow rate and smooth the reading. A lower filter value will also slow the meter's response. For example, if we enter a filter of 0.8, the weight ratio for the new average is:

$$\text{New average} = (80\% \text{ new sample}) + (20\% \text{ last average})$$

Filter range is 0.01 to 1.0, 0.01 being a high filter value and 1.0 = no filter.

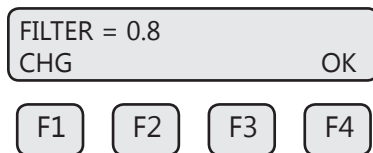

Enter the filter value and then press **OK (F4)**.

Filter	Response (Sec.) 65% of Target
0.09	0.10
0.8	0.15
0.7	0.20
0.6	0.25
0.5	0.30
0.4	0.35
0.3	0.40
0.2	0.60
0.1	1.00
0.05	2.00
0.03	3.00
0.01	10.3

High Flow Rate Alarm

To set the parameters for a High Flow Rate Alarm:

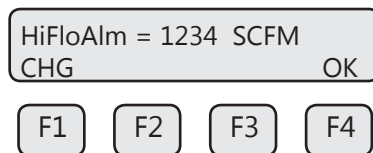

This is the upper flow limit alarm value that can be associated with a discrete output. An alarm code is generated when the flow value exceeds this limit. If no checking is needed, this value should be set to zero. Press **OK (F4)** to accept the value.

Operation

Low Flow Rate Alarm

To set the parameters for a Low Flow Rate Alarm:

LoFloAlm = 100 SCFM		OK	
CHG			
F1	F2	F3	F4

This is the lower flow limit alarm value that can be associated with a discrete output. An alarm code is generated when the flow value is below this limit. If no checking is needed, this value should be set to zero.

Press **OK (F4)** to accept the value.

High Temperature Alarm

To set the parameters for a High Temperature Alarm:

HiTmpAlm = 230 C		OK	
CHG			
F1	F2	F3	F4

This is the upper temperature limit alarm value that can be associated with a discrete output. An alarm code is generated when the temperature value exceeds this limit. If no checking is needed, this value should be set to zero.

Press **OK (F4)** to accept the value.

Low Temperature Alarm

To set the parameters for a Low Temperature Alarm:

LoTmpAlm = 50 C		OK	
CHG			
F1	F2	F3	F4

This is the lower temperature limit alarm value that can be associated with a discrete output. An alarm code is generated when the temperature value is below this limit. If no checking is needed, this value should be set to zero.

Press **OK (F4)** to accept the value.



NOTE! If the programming menu was entered with a **Level 2** password, then more menus will be shown concerning factory-set parameters that should not be changed.

Operation

Calibration Parameters

This menu allows changing the factory calibrated setting of the flow meter and is accessible with a **Level 2** password. Calibration parameter values are set for temperature and pressure at 0 degree C and 760 mmHg.

These settings should normally never be changed except by Fox Thermal Instrument personnel at the factory.

This menu is entered from the base menu and pressing **FLO**, **PRM** and **CAL**.

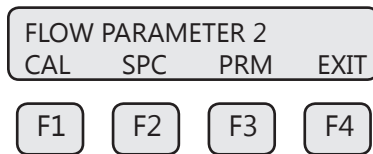

Press **CAL (F1)** then the display will show:

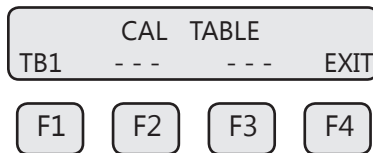

Press **TB1 (F1)** then the display will show:

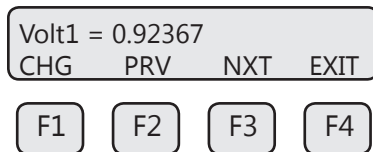

Press **NXT (F3)** then the display will show:

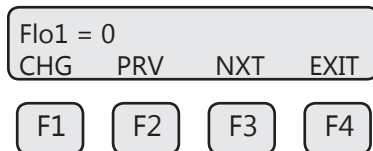

Use the **CHG (F1)** key to change the entry, **PRV (F2)** to move to the previous entry, **NXT (F3)** to move to the next entry and **EXIT (F4)** to return.

Pressing the **NXT (F3)** key will show the data point voltage, then mass velocity, and then go to the next data point. The number after Volt (i.e., Volt1) or Flo (i.e., Flo1) indicated the data point number. The calibration table can hold up to 20 data pair points. Each data point has a voltage and mass velocity associated with it.

Reset Total and Elapsed Time

Enter the flow totalizer and elapsed time screen by pressing the **F3** and **F4** keys at the same

Operation

time in the normal running mode (password required).

RESET TOTAL ?	
NO	YES

F1 F2 F3 F4

Press **YES (F4)** to reset total and **NO (F1)** to cancel.



NOTE! This feature is not available on non-resettable units.

Totalizer Rollover

The FT2A has an automatic roll-over function. The total flow count of the FT2A will roll over after the following values:

Most flow units:	99,999,999,999
MSCFD:	999,999,999
MMSCFM:	9,999,999
MMSCFD:	999,999

Restore Database

Restoring the original factory settings is accomplished from the "Flow Parameter 2" menu by entering a **Level 2** password "9111" and pressing the **SPC** key (**F2**).

FLOW PARAMETER 2			
CAL	SPC	PRM	EXIT

F1 F2 F3 F4

The following will show:

K fact=0%	
CHG	OK

F1 F2 F3 F4

Upon pressing **OK (F4)**, an option to restore the database will follow:

RESTORE DATABASE ?	
YES	NO

F1 F2 F3 F4

Press **YES (F1) ONLY** if you want to restore your database to the initial factory setting that the meter was shipped with. All current user-entered settings will be overwritten.

Operation

The green LP1 LED will flash at a faster pace until the recall is performed. The "RESET CRC" screen will follow "RESTORE DATABASE".

Reset CRC

If the NVRAM CRC check fails (Error Code 36), the programmed settings values will need to be verified and corrected before clearing the error. Call Fox Customer Service if you need assistance.

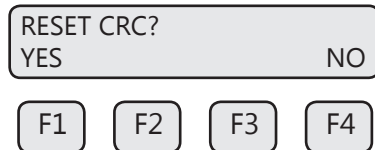

Press **YES (F1) ONLY** if you want to reset the CRC and generate a new CRC value.

Simulation

This menu allows for the simulation of flow rate, temperature and flow input voltage. It should only be used for testing and demonstration purposes.

Make sure to return all of these simulation values to zero, before returning to the normal mode of operation.



NOTE! Simulated values are only enabled when not set to zero.



CAUTION! If the 4-20mA and/or the pulse outputs are connected to controllers, set the controllers to "manual". This will ensure that the simulated signals do not cause false controller action.

The menu is accessible from the main programming menu by pressing **FLO**, and **DGN (F1)**:

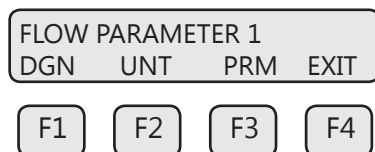

Pressing **DGN (F1)** will show:

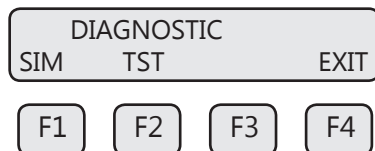

Pressing **SIM (F1)** will show:

Operation

FloSim = 0 SCFM
CHG OK

F1 F2 F3 F4

Enter the value and then press **OK (F4)**.



NOTE! Enter zero to disable this feature.

TmpSim = 0 C
CHG OK

F1 F2 F3 F4

Enter the value and then press **OK (F4)**.



NOTE! Enter zero to disable this feature.

CsvSim = 0 V
CHG OK

F1 F2 F3 F4

Enter the value and then press **OK (F4)**.



NOTE! This value is used to simulate the Current Sense Voltage (CSV) and should be set to zero for normal mode.

ENABLE SIM?
YES NO

F1 F2 F3 F4

Press **YES (F1)** to start the simulation mode, otherwise press **NO (F4)**. Upon pressing either key, the program will return to the FLOW PARAMETER 1 menu.



NOTE! Simulation Mode will be cleared if the power is cycled.

Operation

Fig. 4.4: FT2A Menu Tree - Main Menu

OPERATION

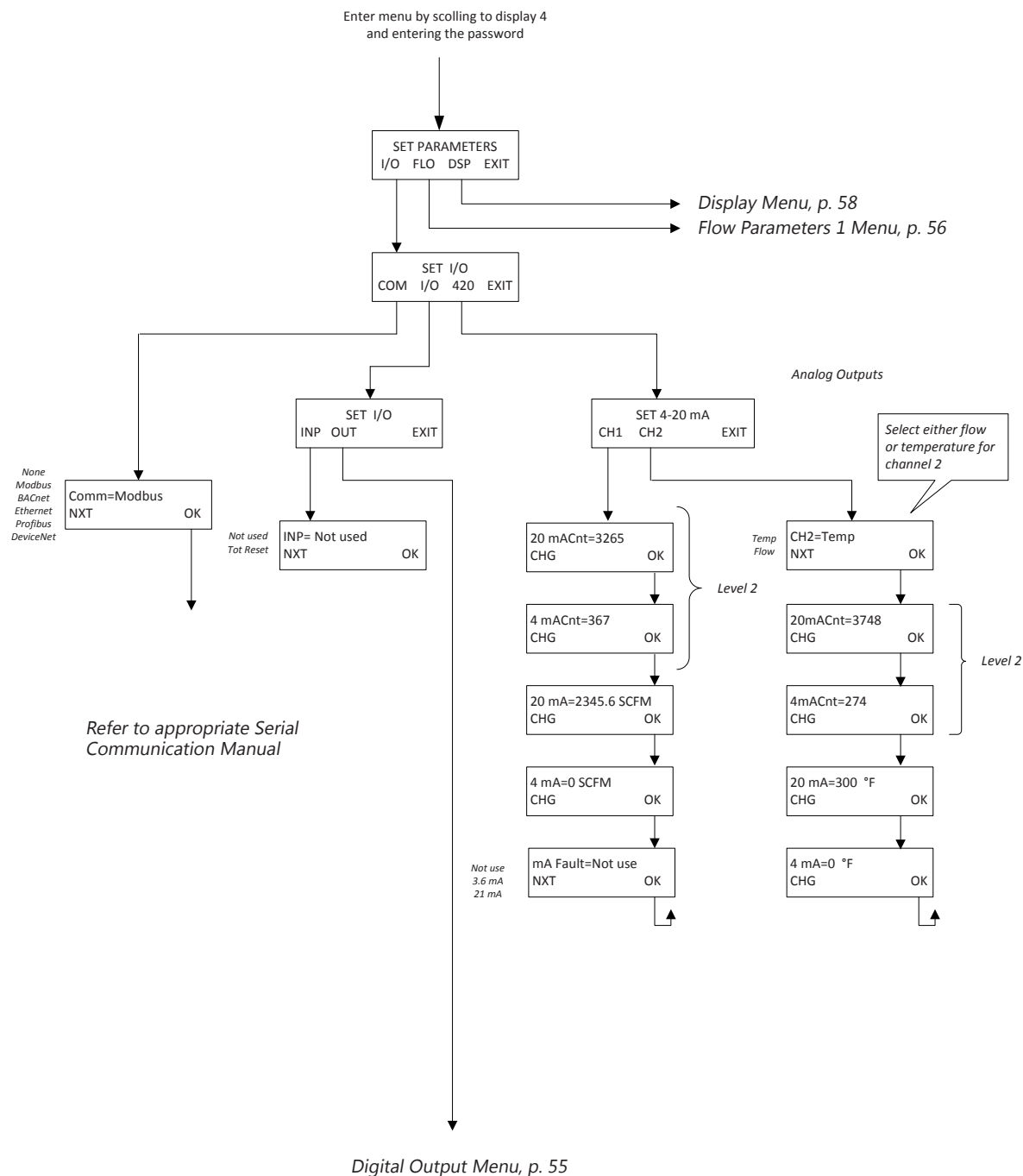

Operation

Fig. 4.5: FT2A Menu Tree - Digital Output

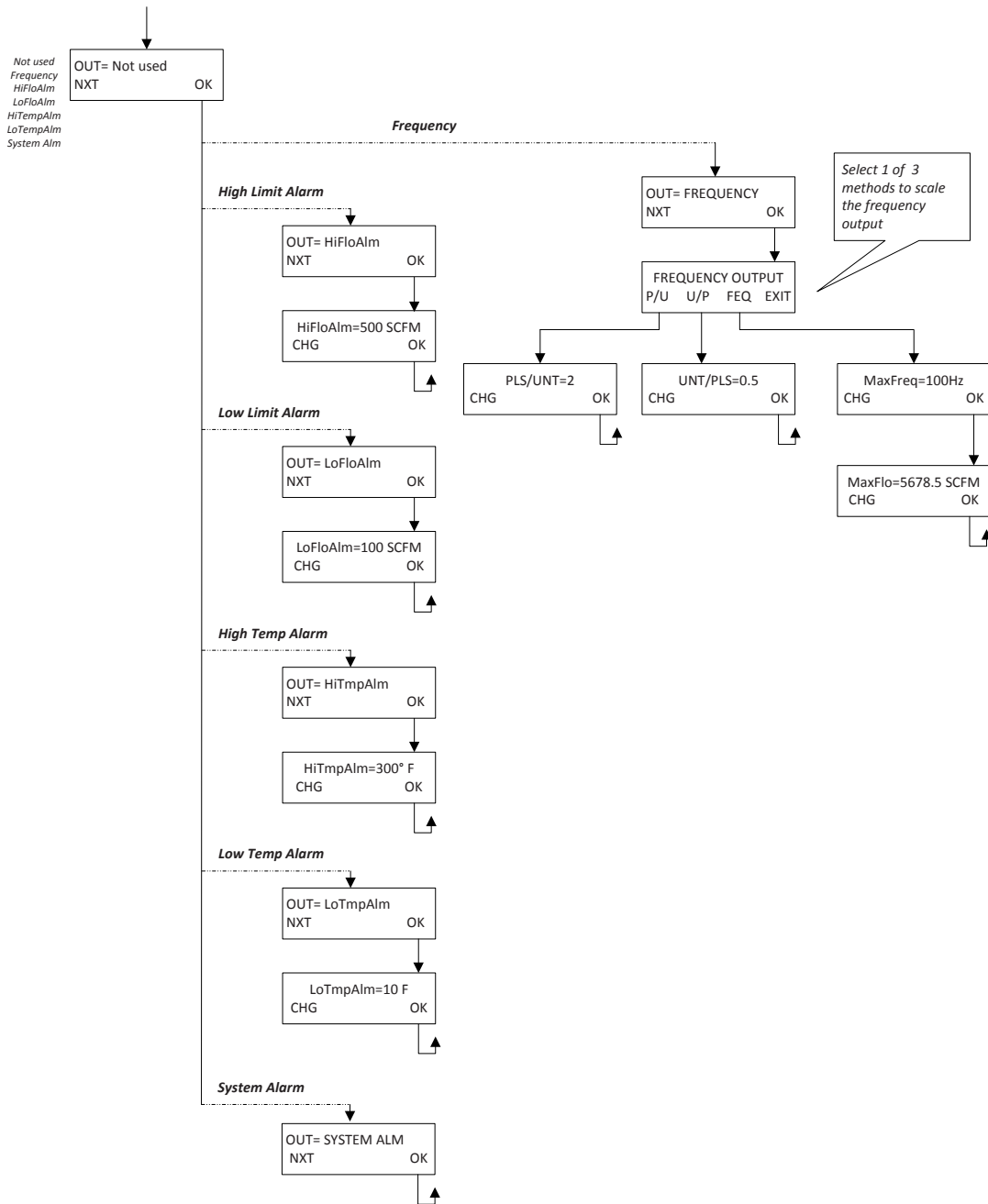

Operation

Fig. 4.6: FT2A Menu Tree - Parameter Menu 1

OPERATION

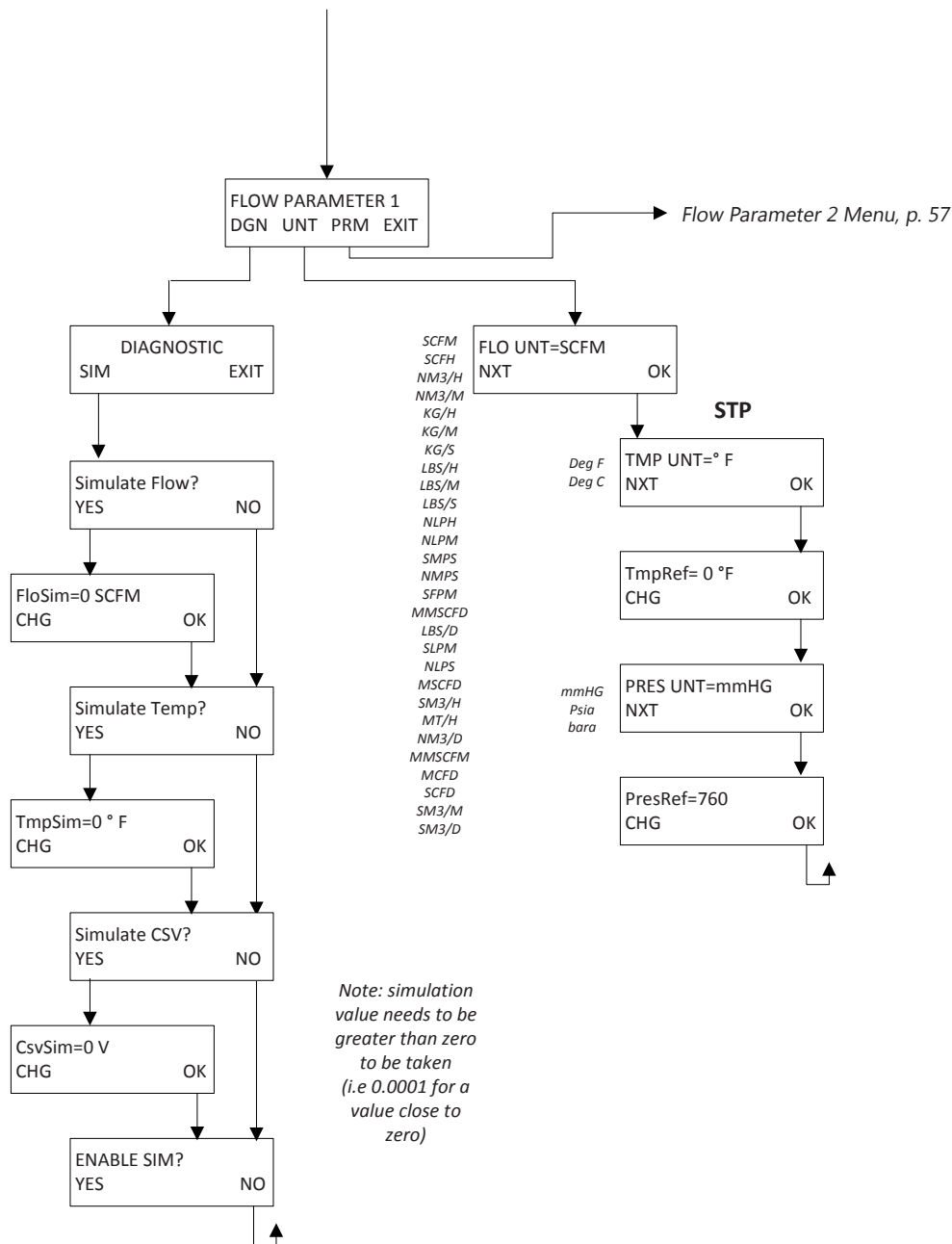

Operation

Fig. 4.7: FT2A Menu Tree - Parameter Menu 2

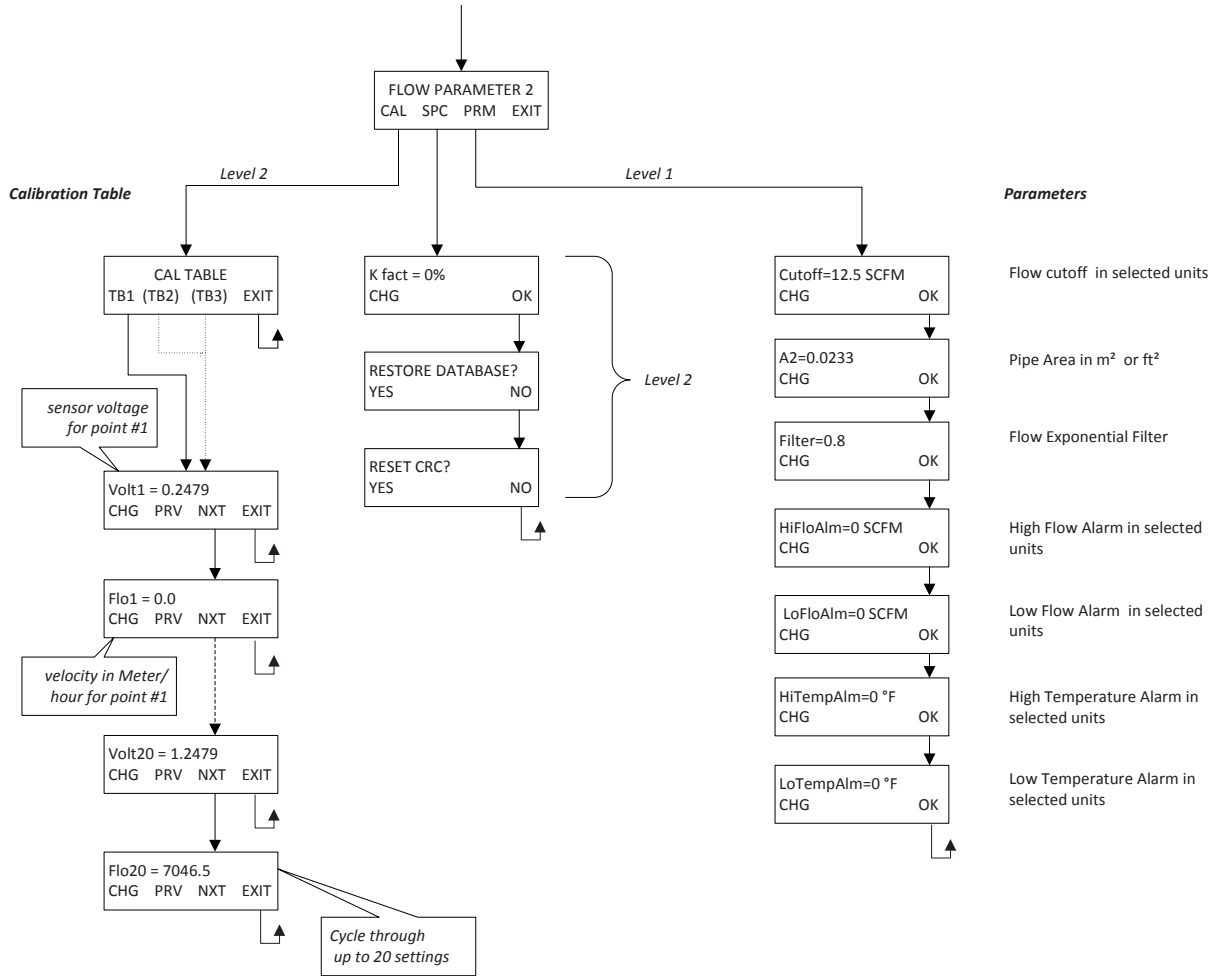

Operation

Fig. 4.8: FT2A Menu Tree - Display Menu

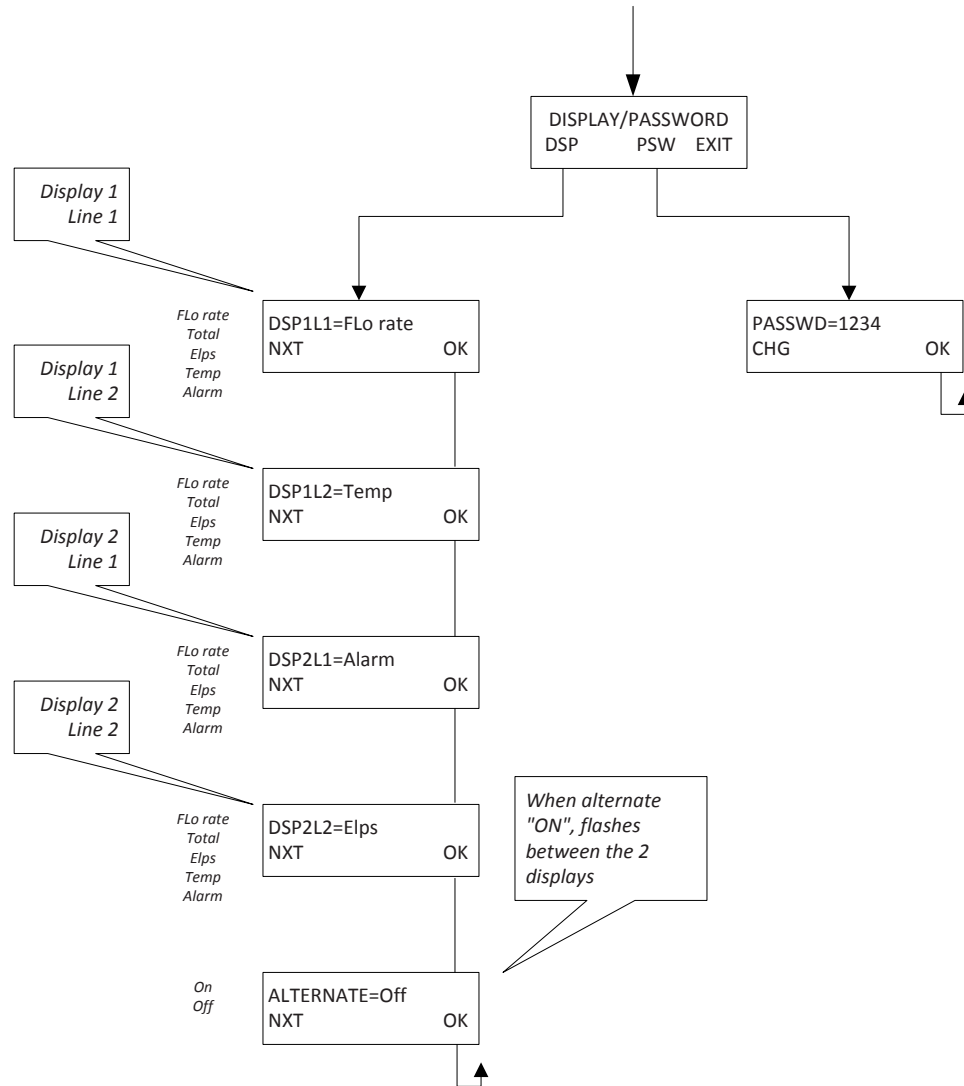

NOTE!

All readings updated every second

- Flo Rate = Flow rate of process gas
- Total = Total flow of process gas
- Elps = Elapsed time since reset of flow total
- Temp = Temperature of process gas
- Alarm = High/Low Flow Rate or Temperature Alarm

Operation

Fig. 4.10: FT2A Menu Tree - Engineering Display

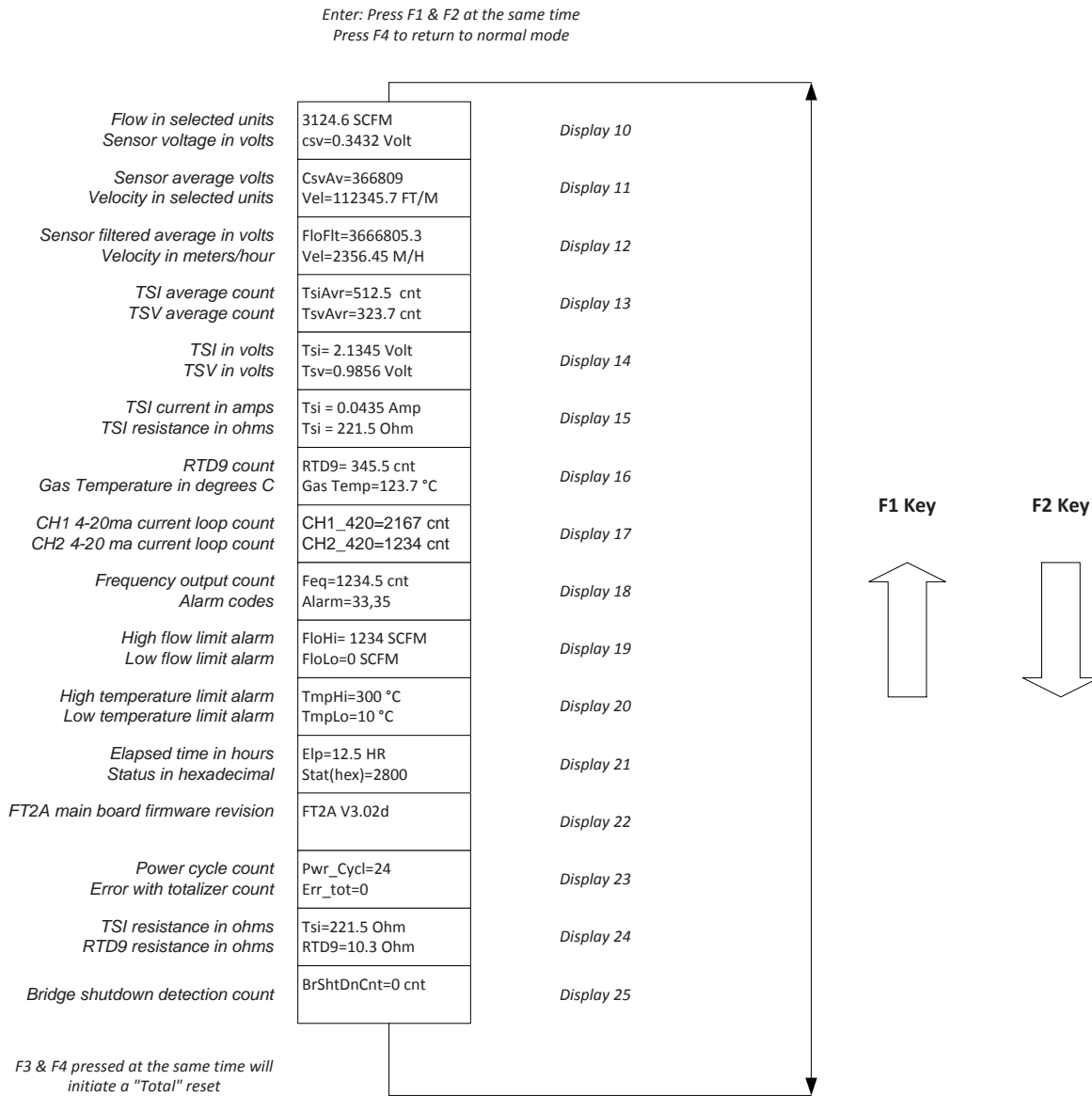

Maintenance

Precautions **(GB)**

WARNING! BEFORE ATTEMPTING ANY MAINTENANCE, TAKE THE NECESSARY SAFETY PRECAUTIONS BEFORE REMOVING THE PROBE FROM THE DUCT (EXAMPLE: PURGE LINES OF TOXIC AND/OR EXPLOSIVE GAS, DEPRESSURIZE, ETC...).

WARNING! EXPLOSION HAZARD. DO NOT REMOVE OR REPLACE COMPONENTS OR FUSES UNLESS POWER HAS BEEN DISCONNECTED WHEN A FLAMMABLE OR COMBUSTIBLE ATMOSPHERE IS PRESENT.

WARNING! EXPLOSION HAZARD. DO NOT DISCONNECT EQUIPMENT WHEN A FLAMMABLE OR COMBUSTIBLE ATMOSPHERE IS PRESENT.

WARNING! TURN OFF INPUT POWER BEFORE REMOVING OR INSTALLING A CIRCUIT BOARD ASSEMBLY FROM THE ENCLOSURE.

Access to Electronics

Accessing electronics is not normally required for maintenance purposes. If a loose connection is suspected, unscrew the rear end-cap of the meter enclosure to access the terminations

CAUTION! BE SURE POWER TO METER IS SWITCHED OFF BEFORE ATTEMPTING TO ACCESS ELECTRONICS. If there is a problem and a loose connection is not found, please contact Fox Customer Service for technical assistance at (831) 384-4300.

Precauciones **(ES)**

¡ADVERTENCIA! ANTES DE INTENTAR CUALQUIER MANTENIMIENTO, TOMÉ LAS PRECAUCIONES DE SEGURIDAD NECESARIAS ANTES QUE RETIRAR LA SONDA DEL DUCTO (EJEMPLO: PURGUE LAS LÍNEAS DE GASES TÓXICOS Y/O EXPLOSIVOS, DESPRESURICE, ETC...).

¡ADVERTENCIA! PELIGRO DE EXPLOSIÓN. NO RETIRE O REEMPLACE COMPONENTES O FUSIBLES A MENOS QUE LA ENERGÍA HAYA SIDO DESCONECTADA SIEMPRE QUE ESTÉ PRESENTE UNA ATMÓSFERA INFLAMMABLE O COMBUSTIBLE.

¡ADVERTENCIA! PELIGRO DE EXPLOSIÓN. NO DESCONECTE NINGÚN EQUIPO CUANDO UNA ATMÓSFERA INFLAMABLE O COMBUSTIBLE ESTÉ PRESENTE PRONTO.

¡ADVERTENCIA! DESCONECTE LA ENERGÍA DE ALIMENTACIÓN ANTES DE REMOVER O INSTALAR UN ENSAMBLE DE TARJETA DE CIRCUITO DEL GABINETE.

Acceso a la Electrónica

Normalmente no se requiere tener acceso a la electrónica para propósitos de mantenimiento. Si se sospecha de una conexión suelta, desatornille la tapa posterior de la caja del medidor para tener acceso a las terminales

PRECAUCIÓN: ASEGÚRESE QUE LA ALIMENTACIÓN DEL MEDIDOR ESTE DESCONECTADA ANTES DE INTENTAR EL ACCESO A LA ELECTRÓNICA. Si existe algún problema y no se encuentra ninguna conexión suelta, por favor póngase en contacto con el Servicio al Cliente de Fox para asistencia técnica al número (831) 384-4300.

Maintenance

Précautions

FR



AVERTISSEMENT ! AVANT TOUTE TENTATIVE DE MAINTENANCE, OBSERVER LES CONSIGNES DE SECURITE NECESSAIRES AVANT DE RETIRER LA SONDÉ DE LA CONDUITE (PAR EXEMPLE, PURGER LES LIGNES DES GAZ EXPLOSIFS/TOXIQUES QU'ELLES POURRAIENT CONTENIR, DEPRESSURISER LE CONTENEUR, ETC.).

AVERTISSEMENT ! RISQUE D'EXPLOSION. NE PAS RETIRER NI REMPLACER DES COMPOSANTS OU DES FUSIBLES SI LA SOURCE D'ALIMENTATION N'A PAS ÉTÉ DEBRANCHÉE DANS UNE ATMOSPHÈRE INFLAMMABLE OU COMBUSTIBLE.

AVERTISSEMENT ! RISQUE D'EXPLOSION. NE PAS DEBRANCHER UN ÉQUIPEMENT DANS UNE AMBIANCE COMBUSTIBLE OU INFLAMMABLE.

AVERTISSEMENT ! COUPER L'ALIMENTATION AVANT DE RETIRER OU D'INSTALLER UN ENSEMBLE DE CARTE DE CIRCUITS IMPRIMÉS DU BOÎTIER.

Accès aux composants électroniques

L'accès aux composants électroniques n'est généralement pas nécessaire dans le cadre de la maintenance. Si une connexion lâche est suspectée, dévisser le capuchon d'extrémité arrière du boîtier du compteur pour accéder aux terminaisons

ATTENTION : S'ASSURER QUE L'ALIMENTATION DU COMPTEUR EST COUPEE AVANT D'ACCÉDER AUX COMPOSANTS ÉLECTRONIQUES. En cas de problème et qu'aucune connexion lâche n'est détectée, veuillez contacter le service client de Fox pour obtenir une assistance technique au (831) 384-4300.

Vorsichtsmaßnahmen

DE



ACHTUNG! BITTE ERGREIFEN SIE DIE ERFORDERLICHEN SICHERHEITSMÄßNAHMEN, BEVOR SIE IRGENDWELCHE WARTUNGSARBEITEN DURCHFÜHREN UND DIE MESSSONDE AUS DEM ROHR ENTFERNEN (BEISPIEL: LEITUNGEN ZUR ENTFERNUNG VON GIFTIGEN UND/ODER EXPLOSIVEN GASEN REINIGEN, DRUCK SENKEN, USW.).

ACHTUNG! EXPLOSIONSGEFAHR. KOMPONENTEN ODER SICHERUNGEN BITTE ERST DANN ENTFERNEN ODER AUSTAUSCHEN, WENN DER STROM GETRENNT WURDE, FALLS EINE ENTZÜNDLICHE ODER BRENNBARE ATMOSPHÄRE VORHANDEN IST.

ACHTUNG! EXPLOSIONSGEFAHR. GERÄT NICHT VOM STROM TRENNEN, WENN EINE ENTZÜNDLICHE ODER BRENNBARE ATMOSPHÄRE VORHANDEN IST.

ACHTUNG! EINGANGSLEISTUNG AUSSCHALTEN, BEVOR LEITERPLATTENBAUGRUPPEN AUS DEM GEHÄUSE AUSGEBAUT ODER IN DIESES EINGEBAUT WERDEN.

Zugriff auf die Elektronik

Der Zugriff auf die Elektronik ist zu Wartungszwecken normalerweise nicht erforderlich. Falls eine lose Verbindung vermutet wird, schrauben Sie die hintere Endkappe des Messgerätgehäuses ab, um auf die Anschlüsse zugreifen zu können.

VORSICHT: STELLEN SIE SICHER, DASS DER STROM AN DAS MESSGERÄT AUSGESCHALTET IST, BEVOR SIE VERSUCHEN, AUF DIE ELEKTRONIK ZUZUGREIFEN. Falls Probleme auftreten und keine lose Verbindung gefunden werden kann, wenden Sie sich bitte zwecks technischer Unterstützung an den Fox-Kundendienst unter der Nummer (831) 384-4300.

Maintenance

Broken or Damaged Probe

If the sensor is broken or damaged, the probe and electronics must be returned to the factory. A new sensor will be installed and calibrated. Refer to "Returning Your Meter" on page 93.

Flow Calibration and Calibration Validation

To ensure continued high accuracy of your Model FT2A Flow Meter, Fox Thermal provides a full NIST traceable calibration. It is recommended that the meter be returned to Fox for a calibration check in our NIST traceable labs after two years of operation.

Fuse Replacement

Verify the fuse is defective by measuring it with an Ohm Meter (Two replacement fuses are provided with each unit). The fuse F1 is located near the power terminal block and can be removed by using tweezers or needle-nose pliers. Replacement fuse is Littelfuse part number 0454.750MR.



WARNING!

- Turn input power OFF before removing or installing a fuse. Use only recommended fuse replacements.
- It is the user's responsibility to install the flow meter in an appropriately designed system with adequate safety protections.
- DO NOT remove the flow instrument from the flow body while the system is under flow conditions.
- This product may experience temperatures from as low as -40F (-40C) and as high as 649F (343C). It is the user's responsibility to take safety precautions regarding operating temperature of the flow meter.
- If large flow body has been purchased, user is advised to use a double sling to prevent rotation of flow body during installation or other method to prevent damage of flow instrument.

Sensor Wiring



NOTE! Sensor terminations are performed at the factory except when the Remote Electronics option is used or ordered.

Sensor Cleaning

The sensor is insensitive to small amounts of residue, but continued use in dirty environments will necessitate periodic cleaning. To inspect the sensor, remove power from electronics and remove the unit from the pipe or duct, exposing the sensor elements. If they are visibly dirty, clean them with water or alcohol (ethanol) using an appropriate brush until they appear clean again. Even though the sensor elements are rugged, avoid touching them with any solid object and use a light touch while cleaning them.

Maintenance

Instructions for Removing and Inserting the Meter from a Pressurized Pipe using the Retractor



WARNING! Possible injury or damage to equipment may occur if the retractor is not used correctly. Please read the following instructions carefully prior to using the retractor.



CAUTION! Never remove the restraint cable without first closing the Ball Valve and bleeding off pressure.



WARNING! When working with the retractor, do not stand or position any part of your body in the path of the flow meter. An injury may occur if the probe is forced outward by system pressure.

How to Remove the Meter from the Retractor (System Pressurized)

Step 1 - Remove the Probe from the Flow Stream

1. Disconnect power from the meter.



NOTE! At 125psig of max system pressure, the probe will have approximately 66 lbs. of force pushing it out.

2. System pressure may force the probe out of the retractor when the Swage Nut is loosened. Hold the flow meter to counteract the force of the system pressure, and carefully loosen and unscrew the Swage nut.
3. Close the ball valve all the way.



CAUTION! At this point there is still pressure inside of the retractor.

Figure 5.1

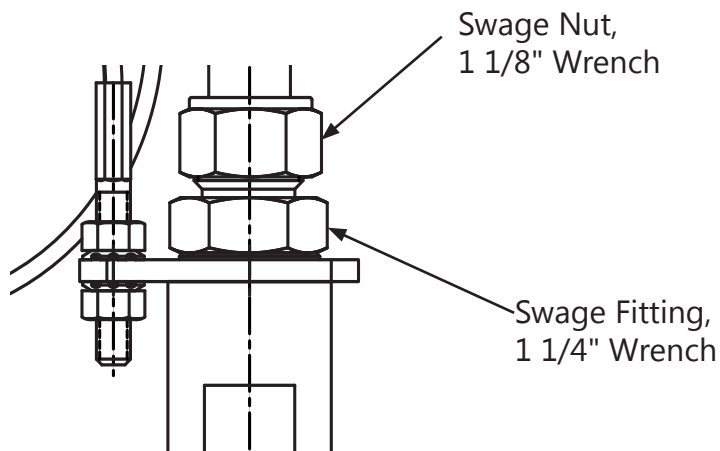

Maintenance

Step 2 - Remove the Probe from the Retractor Body

4. After removing the probe from the flow stream (#1-4 on previous page), slowly loosen the Swage Fitting (see figure 8.2), until the pressure in the retractor is relieved.
5. Retighten the Swage Fitting.
6. Remove the Collar Clamp by using a 3/16" Hex Key.
7. Carefully slide the probe out of the retractor while supporting the meter.

Figure 5.2

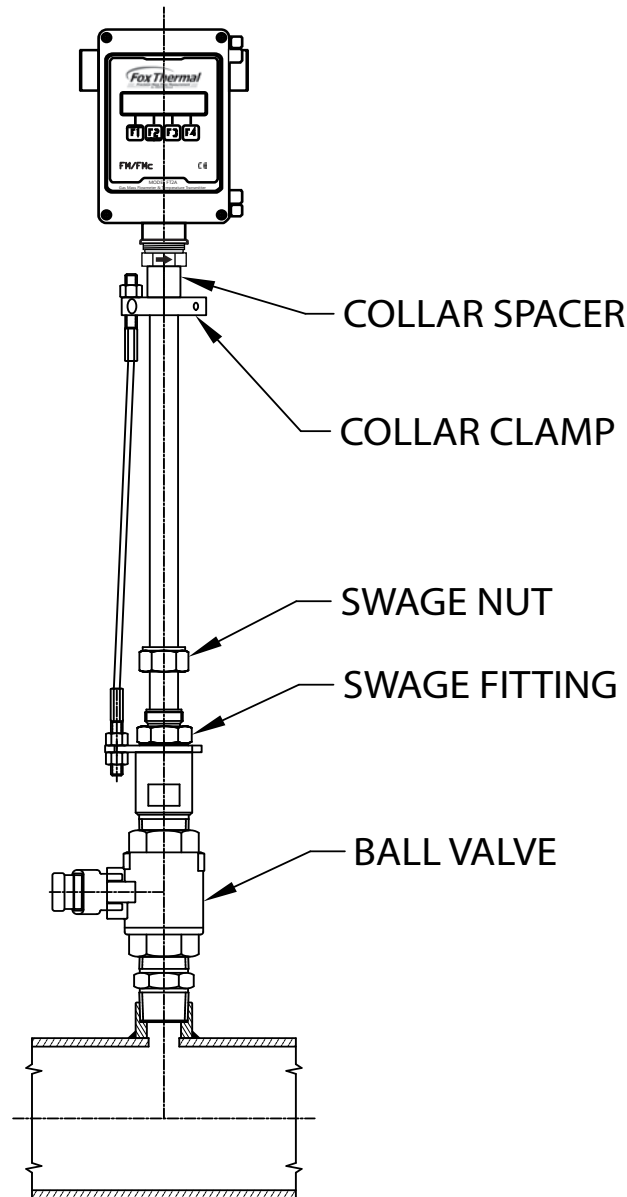

Maintenance

How to Insert the Probe into the Flow Stream (Valve closed, System Pressurized)

1. Carefully, slide the probe into the retractor.
2. Install the collar clamp just below the collar spacer, and tighten it in place on the probe. Slide the probe back out of the retractor until the cable is straight and taut.

Figure 5.3

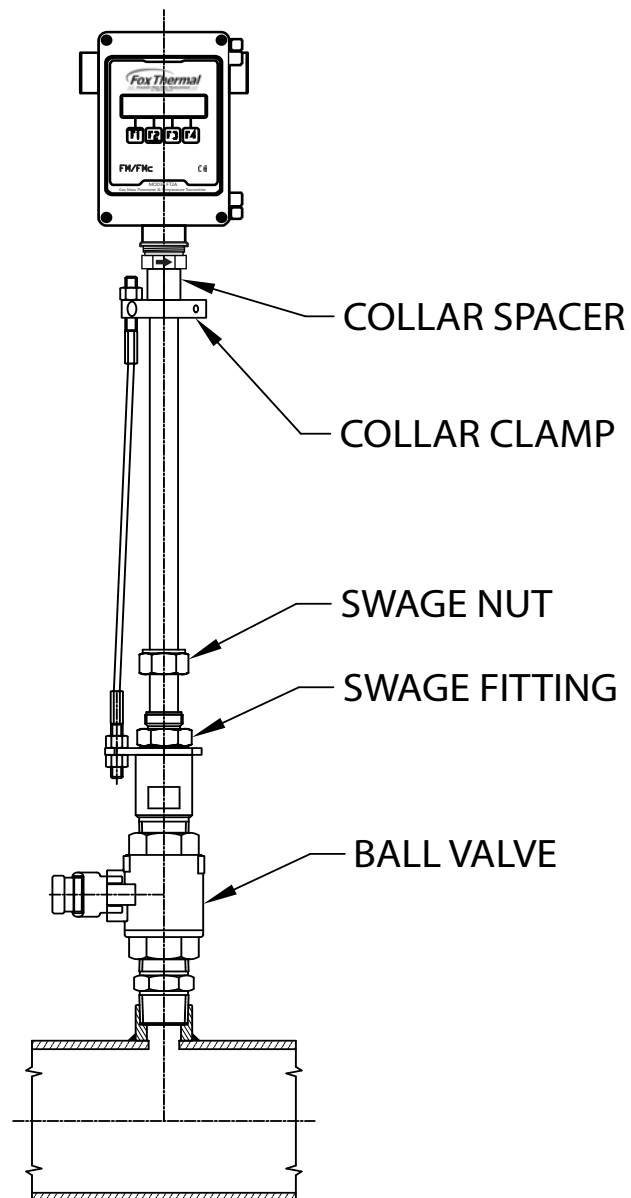

NOTE! At a maximum system pressure of 150psig, the force required to push the probe in place to tighten the Swage Nut will be approximately 66 lbs.

Maintenance

3. Slowly open the ball valve to the full open position. Push the meter and probe into the pipe, then hand tighten the Swage Nut onto the Swage Fitting.
4. Verify that the probe is aligned with the centerline of the pipe, and pointed in the direction of flow.

Figure 5.4

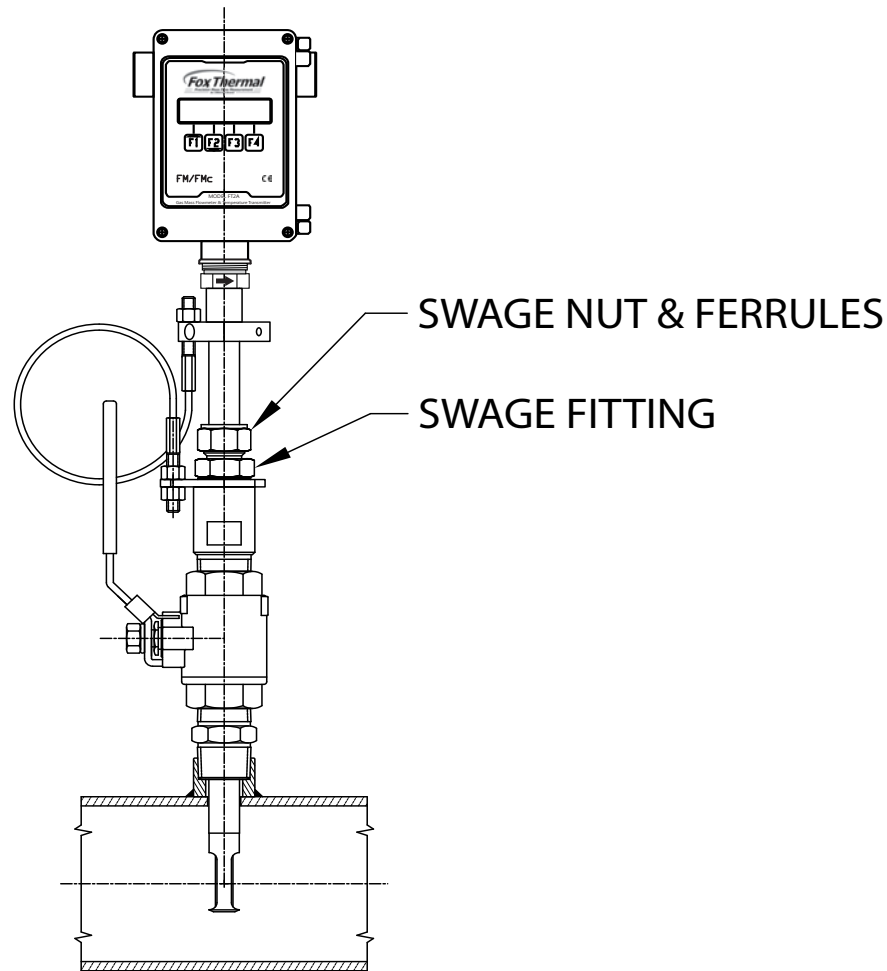

5. Secure the probe in place by tightening the Swage Nut with a 1 1/8" wrench and a 1 1/4" wrench on the Swage Fitting.
6. Power may now be applied to the meter.



Troubleshooting

Troubleshooting



Caution! The electronics, sensor and sensor interconnect wires supplied by Fox are calibrated as a single precision mass flow meter. Interchanging sensors or sensor wiring will affect the accuracy of the flow meter. If you experience any problem with your Model FT2A Flow meter, call Fox Customer Service Department, Technical Assistance at (831) 384-4300.

Problem	Possible Cause	Action
Display Error	Display not operating properly.	Check status of LP1 on the display board. Is green LED blinking once per second? If LED is not blinking, cycle power to reset meter. Call Fox Tech Support.
Meter does not read up to full scale	Calibration table may be corrupted	<ul style="list-style-type: none"> •Check the calibration table for a corrupted location. •Enter the password 9111. •Start on p. 46 of the FT2A manual and follow the steps to get to Flow Parameters 2 menu screen. •Select CAL (F1) •Select NXT (F1) to cycle through calibration table to verify entries match calibration certificate. •Check for CRC error code
Velocity measurement seems low	<p>1.Probe not oriented properly</p> <p>2.Sensor dirty</p>	<p>1.Orient probe per installation sections: Insertion (p. 10), Inline (p. 14).</p> <p>2.Clean sensor (p. 62)</p>



Troubleshooting

Troubleshooting (cont'd)

TROUBLESHOOTING

Problem	Possible Cause	Action
Unit will not power-up	a)No power input b)Bad fuse c)Bad Power supply	<ul style="list-style-type: none"> •Check fuse (F1) located next to TS1 on main board. •Check for correct power supply voltage at TS1 on main board. <p>If fuse is OK and unit still won't power up, call Fox for additional assistance</p>
Meter does not initialize	Electromechanical interference	<ul style="list-style-type: none"> •Check meter power cycles. •Press and release F1 and F2 at the same time; the display will enter Engineering screens. •Press F1 to get to screen #23; record power cycle value. •Press F4 to return to normal operation; monitor meter until problem returns. •Return to screen #23 to see if power cycles have increased; microprocessor is resetting due to EMI electrical noise entering the meter. •Check Power input and output cables grounding and routing.



Troubleshooting

Troubleshooting (cont'd)

Problem	Possible Cause	Action
Velocity measurement is erratic or fluctuating	1. Very turbulent flow	1. Increase dampening (see filter settings in "Flow Parameters" on p. 46)
	2. Sensor dirty	2. Clean sensor (Refer to Maintenance section, p. 62)
	3. Sensor broken	3. Return flow meter to Fox for repair (Refer to p. 93 for shipping instructions)
	4. Probe not mounted securely	4. Remount probe (see Installation section, p. 10 and p. 14); must be mounted securely without vibration. If vibration persists, choose a new mounting location without vibration.
	5. Malfunction in flow meter	5. Return flow meter to Fox for repair (Refer to p. 93 for shipping instructions)
	6. Meter installed incorrectly	6. Re-install meter according to instructions (Refer to installation section, p. 10 and p. 14)



Installation Problems

The following is a summary listing of problems that may be encountered with the installation of the FT2A Thermal Mass Flow Meter.

1. *Improper wiring connections for power and/or 4-20mA output signal.*

The FT2A requires a separate power source for the main board and the two 4-20mA output signals. Two wires supply 24VDC power to the main board. Two wires are used for each of the 4-20mA output signals. Refer to Figure 3.4 and Figure 3.5 (p. 25). Also refer to "Wiring Precautions" and "Helpful Hints" in Wiring section (p. 20) for further guidance.

2. *Inadequate power source.*

For those models that are powered by 24VDC, a 24VDC $\pm 10\%$, 0.7 Amp or greater power supply is recommended. If the voltage supplied is not within this range or if the power supply is not rated for 25 watts minimum, a variety of problems can occur including inaccurate flow readings, dim display and faulty programming action. The input voltage must be within the range of 21.6 to 26.4VDC as measured at the power input terminals of the flow meter electronics.

3. *Flow measurement seems inaccurate.*

- Check to ensure that the flow meter is installed so that the Flow Direction Arrow engraved on the flat surface of the fitting below the electronics housing is properly pointing in the direction of flow. Refer to "Fig. 2.4: Orientation of Type Flow Meter" on page 13. If not, change orientation of meter.
- If you have a Fox insertion type flow meter, check that the insertion depth of the sensor/probe is correct. The end of the probe should be adjusted as per Figure 2.2 (p. 12).
- For inline meter types, ensure that there are a minimum of ten diameters of straight pipe upstream of the sensor and five diameters downstream ($\frac{1}{4}$ " meters: 6" [152 mm] of straight, unobstructed pipe upstream and downstream required). For insertion meter types, ensure that there are a minimum of fifteen diameters of straight pipe upstream of the sensor and ten diameters downstream. If complex flow disturbances are upstream of the sensor, extension of the straight pipe may be required to ensure accurate flow measurement. Contact Fox for assistance.
- Ensure that pipe area data in the meter matches data on the Fox Calibration Certificate. The pipe internal cross sectional area is programmed into the flow meter through the front panel (see Flow Parameters, p. 46). This area is programmed in square feet or square meters. The Calibration Certificate delivered with the flow meter contains the area that was programmed into the flow meter at the Fox factory. Check to ensure that this area is correct.

4. *Erratic flow reading (especially a flow reading spiking high).*

This may be a symptom of moisture in the flow stream. Fox flow meters are designed to work in relatively dry gas applications only. Contact Fox to discuss resolutions to this problem.



Troubleshooting

Installation Problems (Cont'd)

5. *Flow meter is not responding to flow.*

This problem could be caused by a number of reasons:

- Check to ensure adequate power is supplied to the flow meter. If things appear to be correct, perform this functional test before calling Fox. Carefully remove the probe and sensor from the pipe or flow body. **CAUTION!** the sensor is HOT. For those flow meters with a display - and if the display is reading zero - blow on the sensor to see if a response occurs. If nothing happens, take a damp rag or sponge and place it in contact with the sensor. A reading should occur. Contact Fox Customer Service with this information.
- A corrupted calibration table may lead to a zero flow reading. Verify that all Cal Flow Parameter settings are correct by accessing the "Calibration Parameters" information on meter (see p. 50). Check meter data for any non-whole numbers and call customer service for assistance.

6. *Display and/or 4-20mA signal reading above zero flow when no flow is occurring in the pipe.*

If the reading is less than 5% of full scale, it is likely this is a normal condition caused by convection flow created by the heated sensor. It does not mean that the zero of the instrument is improperly set. The Fox sensor is extremely sensitive to gas flow and can even read the small flow caused by convection. If this is an unacceptable condition, please contact Fox Customer Service for alternatives.

7. *Mismatched serial numbers*

If you have more than one meter, you must ensure that the serial numbers of meter, remote, and/or flow body match one another. These items have been manufactured and calibrated to operate as a unit and cannot be mismatched.



Troubleshooting

Alarm Codes

Information to diagnose and clear alarm codes is on p. 57 under the Menu Tree section. Enter password (9111) and follow the block diagram to get to the section affected by the error code.

Alarm Code	Reason	Action
13	Flow rate above high limits	Refer to the PARAMETER MENU 2 section on p. 46 of this Manual to verify limit is within range. Check ALM = HiFloAlm under PRM.
14	Flow rate below low limits	Refer to the PARAMETER MENU 2 section on p. 46 of this Manual to verify limit is within range. Check ALM = LoFloAlm under PRM.
15	Temperature above high limits	Refer to the PARAMETER MENU 2 section on p. 46 of this Manual to verify limit is within range. Check ALM=HiTempAlm under PRM.
16	Temperature below low limits	Refer to the PARAMETER MENU 2 section on p. 46 of this Manual to verify limit is within range. Check ALM = LoTempAlm
22	Sensor out of range	Refer to the ENGINEERING DISPLAY MENU on p. 59 of this Manual and the Fox factory Calibration Certificate to check CSV voltage. Compare Display 10 value to Calibration Certificate CSV voltage and verify it's within range.
23	Velocity out of calibration table range	Refer to the ENGINEERING DISPLAY MENU on p. 59 of this Manual and the Fox factory Calibration Certificate to check CSV voltage. Compare Display 10 value to Calibration Certificate CSV voltage and verify it's within range.
24	Check settings	One or more internal settings are corrupted or out of spec. Contact Fox Service for instructions to verify settings.
25	Simulation mode	Meter is in Simulation Mode. Refer to the PARAMETER MENU 1 section on p. 52 of this Manual. Use the SIM Section under Diagnostics to return to normal operation.
26	Frequency output over range	Refer to the DIGITAL OUTPUT MENU on p. 55 of this Manual. Verify the Frequency Output settings are within limits.
32	4-20mA for flow rate is out of range	Refer to the MAIN MENU on p. 54 of this Manual. Use the Set I/O section to verify range limits under FLO Set 4-20mA.
33	4-20mA for temperature is out of range	Refer to p. 36 of this Manual. Use the Set I/O section to verify range limits under FLO Set 4-20mA. Channel #2 can be set for flow or temperature. Be sure to check the Alarm limits (refer to p. 46).
34	Busy	Meter is recalculating new parameters.



Troubleshooting

Alarm Code	Reason	Action
35	Sensor Bridge Shutdown	The FT2A probe is getting too hot. Open wiring compartment and check sensor wiring.
36	Database CRC Error	Refer to the Reset CRC section on pages 50 and 51 of this manual. Verify the programmed values are verified and corrected before clearing the error. Contact Fox Service Department for possible causes.
37	Totalizer Error Detected	See "Reset the Total and Elapsed Time" on p. 50 for steps to clear Error Code. Contact Fox for possible causes.

Appendices

Performance Specs

Flow Accuracy:

Inline meter: $\pm 1\%$ of reading $\pm 0.2\%$ of full scale.

¼" size: 6" (152 mm) of straight, unobstructed pipe upstream and downstream required.

All other sizes: 8 diameters of straight, unobstructed pipe upstream and 4 downstream required.

Insertion meter: $\pm 1\%$ of reading $\pm 0.2\%$ of full scale.

15 diameters of straight, unobstructed pipe upstream and 10 downstream required.

Flow Repeatability: $\pm 0.2\%$ of full scale

Flow Response Time: 0.9 seconds (one time constant)

Temperature Accuracy:

$\pm 1.8^\circ\text{F}$ ($\pm 1.0^\circ\text{C}$) over the range -40 to 250°F (-40 to 121°C);

$\pm 3.6^\circ\text{F}$ ($\pm 2.0^\circ\text{C}$), over the range 250 to 650°F (121 to 343°C);

Minimum velocity 60 SFPM.

Calibration: Factory Calibration to NIST traceable standards

Operating Specs

Units of Measurement (field selectable):

SCFM, SCFH, NMPS, NM3/M, NM3/H, NM3/D, NLPS, NLPM, NLPH, MCFD, MSCFD, SCFD, MMSCFD, MMSCFM, SMPS, SM3/D, SM3/H, SM3/M, LB/S, LB/M, LB/H, LB/D, KG/S, KG/M, KG/H, SLPM, SFPM, MT/H

Flow Rates for Insertion Flow Meter:

15 to 60,000 SFPM (0.07 to 280 NMPS) - Air at 70°F (20°C) & 1 ATM

Turndown: up to 1000:1; 100:1 typical

Typical Flow Ranges for Insertion Flow Meters

Pipe size	SCFM	MSCFD	NM ³ /hr
1.5" (40mm)	0-840	0-1,220	0-1,325
2" (50mm)	0-1,400	0-2,020	0-2,210
2.5" (63mm)	0-2,000	0-2,880	0-3,150
3" (80mm)	0-3,100	0-4,440	0-4,890
4" (100mm)	0-5,300	0-7,650	0-8,360
6" (150mm)	0-12,000	0-17,340	0-18,930
8" (200mm)	0-20,840	0-30,020	0-32,870
10" (250mm)	0-32,800	0-47,250	0-51,740
12" (300mm)	0-46,600	0-67,180	0-73,500

Appendices

Operating Specs (cont'd)

Full Scale Flow Ranges for In-Line Flow meters:

Size	SCFM	MSCFD	NM ³ /hr
0.25"	0-7.5	0-10.8	0-11.8
0.5"	0-125	0-180	0-200
0.75"	0-220	0-320	0-350
1"	0-360	0-520	0-570
1.25"	0-625	0-900	0-990
1.5"	0-840	0-1,220	0-1,325
2"	0-1,400	0-2,020	0-2,210
2.5"	0-2,000	0-2,880	0-3,150
3"	0-3,100	0-4,440	0-4,890
4"	0-5,300	0-7,650	0-8,360
6"	0-12,000	0-17,340	0-18,930

NOTE! Standard conditions of air at 70°F and one atmosphere. Consult factory for other gases and for flow ranges above those listed.

Gas Pressure (maximum):

Insertion: 500 psig (34.5 barg)

Inline with NPT: 500 psig (34.5 barg)

Inline with 150lb. flange: 230 psig (16 barg)

Retractor Assembly: 125 psig (8.62 barg)

High pressure (crank) retractor: NPT 600 psig (41.4 barg), ANSI 150 flange & ANSI 300 flange, no valve supplied.

Check with factory for higher pressure options.

NOTE! Pressure ratings stated for temperature of 100°F (38°C).

Relative Humidity: 90% RH maximum, non-condensing

Temperature:

ST sensor: -40 to 250°F (-40 to 121°C)

HT Sensor: -40 to 650°F (-40 to 343°C)

Enclosure: -40 to 158°F (-40 to 70°C) DC power*

-4 to 158°F (-20 to 70°C) AC power

***NOTE!** Display dims below -4°F (-20°C), function returns once temperature rises again.

Remote sensor junction box ambient temperature: -40 to 212°F (-40 to 100°C)

Input Power (without the Anybus serial communication option):

24 VDC \pm (± 10%), 0.4 Amps (standard DC power)

100 to 240VAC~(+10%/-15%), 50-60Hz, 0.2 Amps (with AC power option)

Input Power (with Anybus serial communication option):

24 VDC \pm (± 10%), 0.7 Amps (standard DC power)

100 to 240VAC~(+10%/-15%), 50-60Hz, 0.2 Amps (with AC power option)

NOTE! Fluctuations of AC and DC power supply are not to exceed \pm 10% of rating.

Class I Equipment (Electrical Grounding Required for Safety).

Installation (Over-voltage) Category II for transient over-voltages.

Appendices

Operating Specs (cont'd)

Outputs:

Two isolated 4-20mA outputs (output one is for flow rate and output two is programmable for flow rate or temperature); fault indication per NAMUR NE43.

Isolated pulse output 0 to 100Hz, 5 to 24 volts p/p for flow (the pulse output can be used as an isolated solid state output for alarms); 20mA max.

Serial Communication:

USB connector for connecting to a laptop or computer is standard; free PC-based software tool - FT2A View™ - provides complete configuration, remote process monitoring, and data logging functions.

Optional isolated communication outputs: RS485 Modbus, BACnet MS/TP, Profibus-DP, DeviceNet, or Ethernet Modbus TCP.

4-20mA Loop Verification:

Simulation mode used to align 4-20mA output with the input to customer's PLC/DCS.

Physical Specs

Sensor material:

316 stainless steel standard; Hastelloy C276 optional

Enclosure:

NEMA 4X, aluminum, dual conduit entries with 3/4" NPT or optional M20 x 1.5mm.

Remote Sensor Cable:

To Fox remote enclosure: 5-conductor, 18 AWG, twisted, shielded, 100 feet maximum.

Insertion Flow Meter Installation:

Fox-supplied compression fitting connects to customer-supplied 3/4" female coupling welded to pipe.

Appendices

Agency Approvals

CE: Approved

EMC Directive; 2004/108/EC

Emissions and Immunity Testing: EN61326-1:2008

Low Voltage Directive (LVD): 2006/95/EC

Product Safety Testing: EN 61010-1: 2010

Pressure Equipment Directive: 97/23/EC

Weld Testing: EN ISO 15614-1 and EN ISO 9606-1, ASME B31.3

FM and FMc: Approved

Class I, II, III, Division 2, Groups A, B, C, D, E, F, G, T4A hazardous locations.

NEMA 4X Approved

NOTE! The EU Pressure Equipment Directive (PED) requires that the minimum ambient and fluid temperature rating for carbon steel flow bodies not be below -29C.

Appendices

Scope

This section describes added features to the standard FT2A flow meter when using the 2 gas curves firmware option.

FT2A 2 Gas Curves

The 2 Gas Curves firmware allows the use of two different calibration tables when running with different gases. One of two methods can be used to switch between the two calibration curves:

1) Use of Contact Input:

When the contact input is programmed for curve switching, an open contact will select curve #1 and a contact closure will select curve #2.

2) Use of the Keypad:

If the contact input is not programmed for curve switching, pressing F2 and F3 simultaneously will prompt an operator to manually switch curve upon entering a password and confirming the action by pressing the appropriate key.

Pressing F2 & F3 simultaneously:

SWITCH TO CRV 1?			
NO			YES
F1	F2	F3	F4

Password needs to be entered if active (default: 1234):

PASSWORD: _			
UP	DN	NXT	OK
F1	F2	F3	F4

After entering a valid password, a brief confirmation message will be displayed for 1 second:

SWITCH TO CRV 1			
F1	F2	F3	F4

Appendices

3) Programming Contact Input for Curve Switching:

Enter the menu using steps outlined in "Discrete Input Settings" section (p. 40) and select "Switch CRV". Please note that the flow meter needs to be programmed for 2 gas curves at the Fox factory before you can select this function. Flow meters are shipped with pre-programmed user requested settings.



Selections are: "Not used"
"Tot Reset"
"Switch Crv"

4) Programming Densities for Curve 1 and Curve 2:

When the selected flow unit is mass/time, a separate density will be used for each curve if the meter has been programmed for 2 gas curves. To change the densities:

Go to the unit menu following "Unit Settings" section.

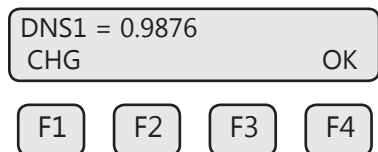

DNS1 is the density associated with curve 1. Change it as needed and press OK.

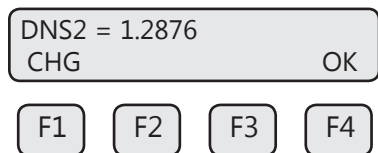

DNS2 is the density associated with curve 2. Change it as needed and press OK.

Helpful Hint:

From normal display mode, press F4 to view the current gas curve selection.

Appendices

5) Programming 4-20mA settings for Curve 1 and Curve 2:

When the meter has been programmed for 2 gas curves, 2 sets of 4-20mA settings for flow rate are used. To program these settings:

Go to the 4-20mA setting following the "Analog 4-20mA Settings" section.

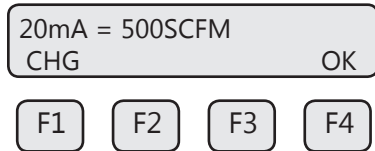

20mA is the upper limit associated with curve 1. Change it as needed and press OK.

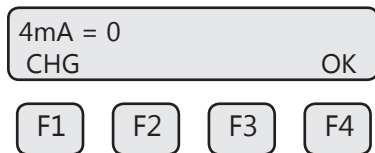

4mA is the lower limit associated with curve 1. Change it as needed and press OK.

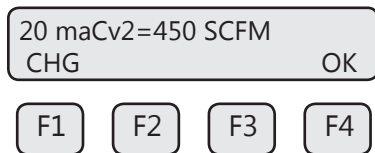

20 maCv2 is the upper limit associated with curve 2. Change it as needed and press OK.



4 maCv2 is the lower limit associated with curve 2. Change it as needed and press OK.

Appendices

6) Operation:

- To avoid confusion, only one of two techniques is enabled. If the contact input is assigned to switch gas curves, then the ability to switch using the F2 and F3 function keys on the front panel is disabled.
- Two totalizers (Total 1 and Total 2) and two elapsed time counters are available on the display and through the USB serial communication. The reset function will reset all totalizers and elapsed time counter to zero.
- In the event of a power failure, the software will remember the last curve in use. Upon powering up again, the FT2A unit will continue to use that curve.
- Switching between gas curves will require a password unless the password is set to "0", which disables it.
- The calibration certificates for flow meters with 2 gas curves will identify which gas is Gas 1 and Gas 2.
- When measuring in mass units, a density value must be entered for each gas curve.

Appendices

Fig. 7.1 Local Insertion Meter with Retractor Dimensions

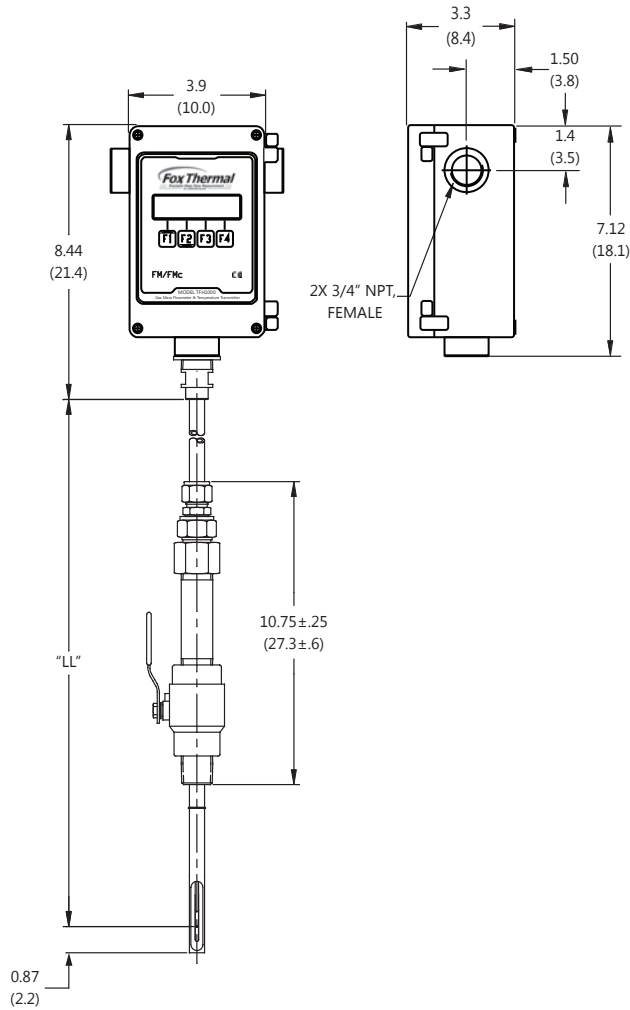

Table 7.1 Local Insertion Meter with Retractor

Probe Size [model code]	Probe Size [inches]	Dimension "LL" ± .10 [inches / centimeters]
15R	15"	15.0" (38.1cm)
18R	18"	18.0" (45.7cm)
24R	24"	24.0" (61.0cm)
30R	30"	30.0" (76.2cm)
36R	36"	36.0" (91.4cm)

Appendices

Fig. 7.2 Remote Insertion Meter with Retractor Dimensions

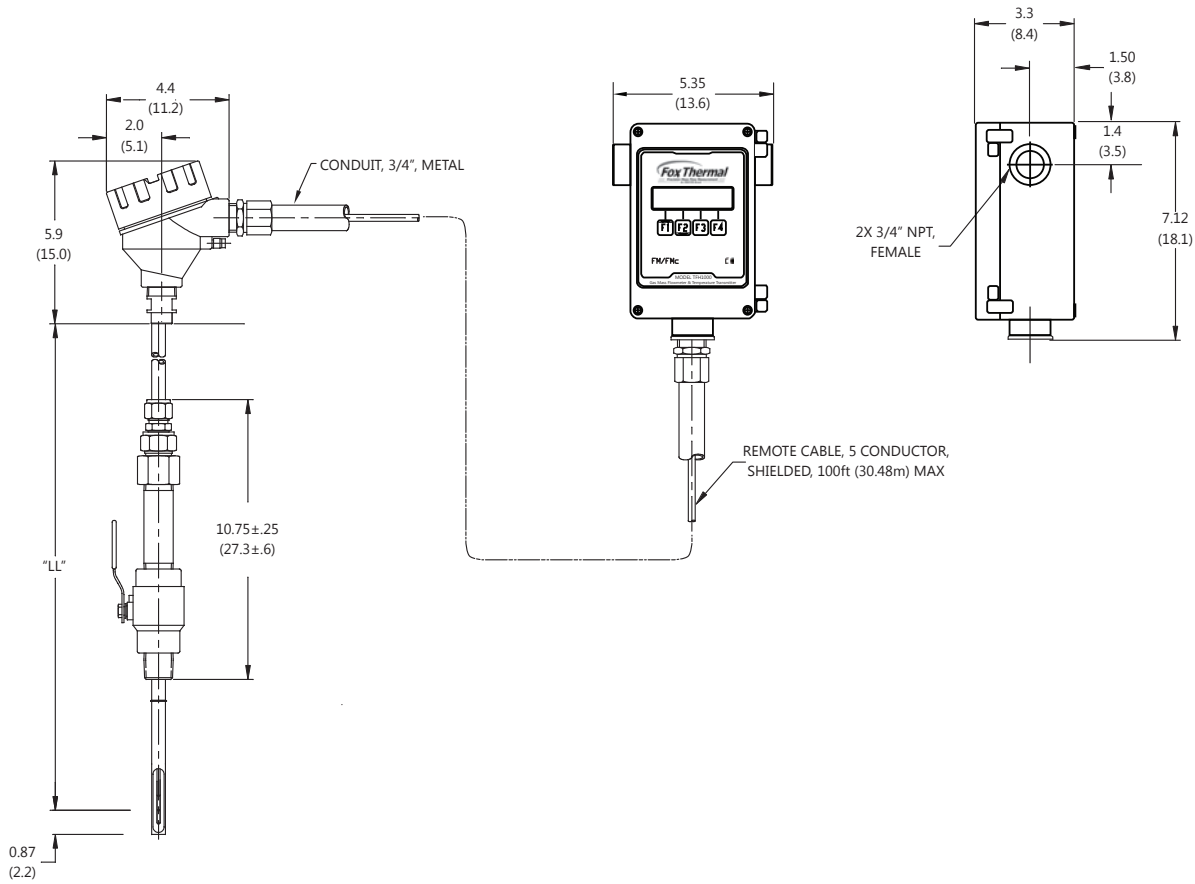

Table 7.2 Remote Insertion Meter with Retractor

Probe Size [model code]	Probe Size [inches]	Dimension "LL" ± .10 [inches / centimeters]
15R	15"	15.0" (38.1cm)
18R	18"	18.0" (45.7cm)
24R	24"	24.0" (61.0cm)
30R	30"	30.0" (76.2cm)
36R	36"	36.0" (91.4cm)

Appendices

Fig. 7.3 Insertion Meter Dimensions

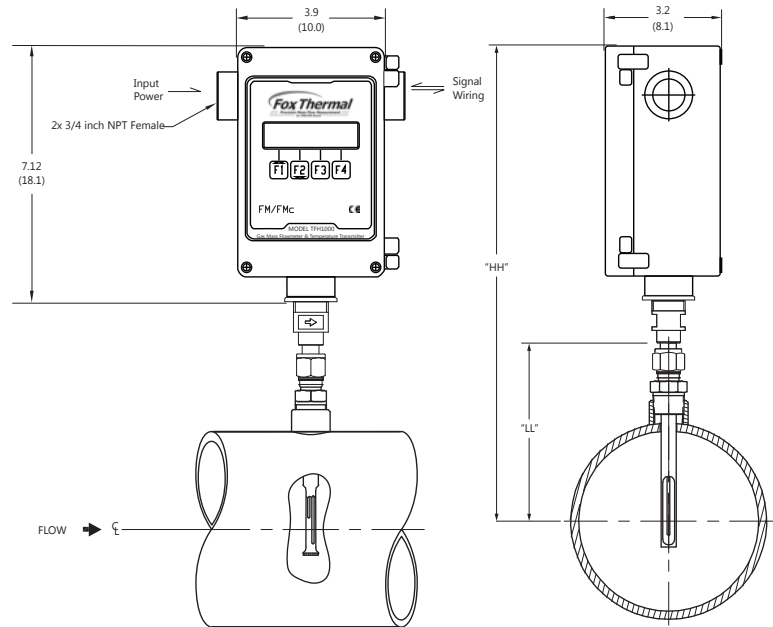

Table 7.3 Insertion Meter with 316 stainless steel probe

Probe Size [model code]	Probe Size [inches]	Dimension "LL" ± .10 [inches / centimeters]	Dimension "HH" ± .25 [inches / centimeters]
06I	6"	6.0" (15.2cm)	14.4" (36.7cm)
09I	9"	9.0" (22.9cm)	17.4" (44.3cm)
12I	12"	12.0" (30.5cm)	20.4" (51.9cm)
15I	15"	15.0" (38.1cm)	23.4" (59.5cm)
18I	18"	18.0" (45.7cm)	26.4" (67.1cm)
24I	24"	24.0" (61.0cm)	32.4" (82.4cm)
30I	30"	30.0" (76.2cm)	38.4" (97.6cm)
36I	36"	36.0" (91.4cm)	44.4" (112.9cm)

Appendices

Fig 7.4: Insertion Remote Meter Dimensions

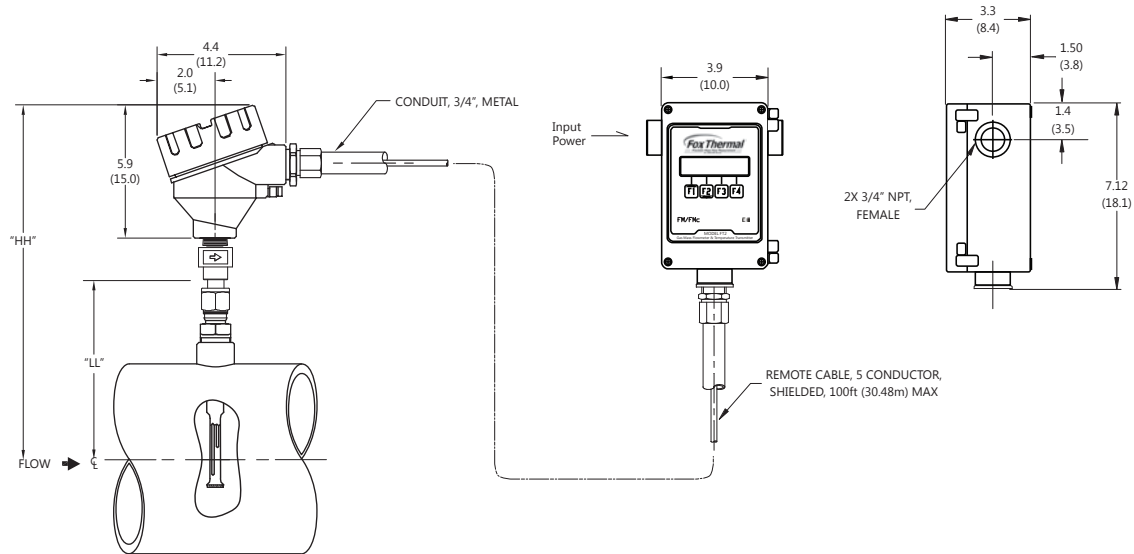

Table 7.4 Insertion Remote Meter with 316 stainless steel probe

Probe Size [model code]	Probe Size [inches]	Dimension "LL" ± .10 [inches / centimeters]	Dimension "HH" ± .25 [inches / centimeters]
06I	6"	6.0" (15.2cm)	11.9" (30.2cm)
09I	9"	9.0" (22.9cm)	14.9" (37.9cm)
12I	12"	12.0" (30.5cm)	17.9" (45.5cm)
15I	15"	15.0" (38.1cm)	20.9" (53.1cm)
18I	18"	18.0" (45.7cm)	23.9" (60.7cm)
24I	24"	24.0" (61.0cm)	29.9" (76.0cm)
30I	30"	30.0" (76.2cm)	35.9" (91.2cm)
36I	36"	36.0" (91.4cm)	41.9" (106.4cm)

Appendices

Fig. 7.5: Inline Meter with 316 Stainless Steel Flow Body and NPT End Connections Dimensions

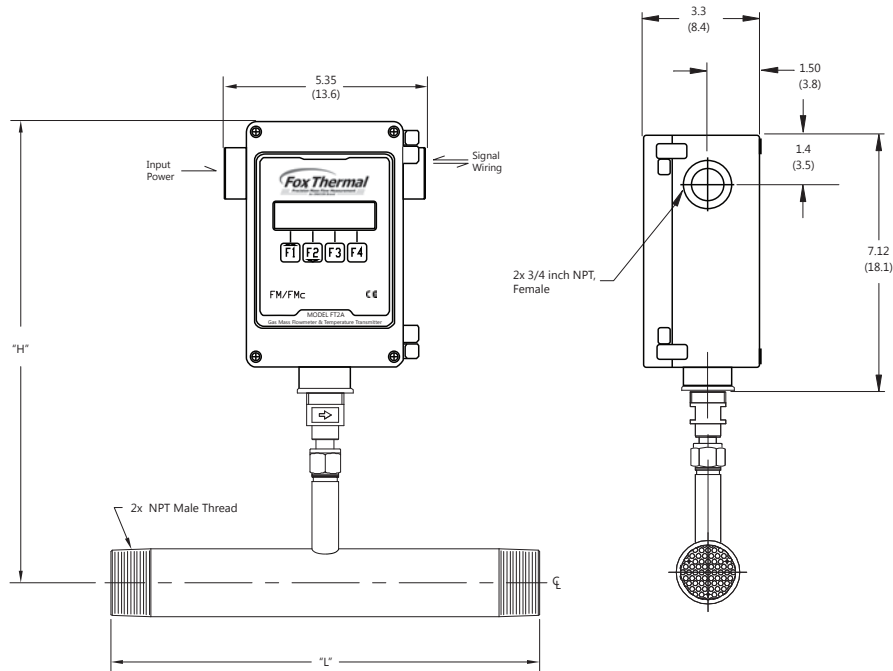

Table 7.5 Inline Meter with 316 stainless steel flow body and NPT End Connections

Body Size [model code]	Body Size [inches]	Dimension "L" ± .10 [inches]	Dimension "H" ± .25 [inches / centimeters]
025P	0.25"	5.8"	12.5" (31.8cm)
05P	0.50"	12"	12.5" (31.8cm)
075P	0.75"	12"	12.5" (31.8cm)
10P	1.00"	12"	12.5" (31.8cm)
125P	1.25"	12"	12.5" (31.8cm)
15P	1.50"	12"	12.5" (31.8cm)
20P *	2.00"	12"	12.5" (31.8cm)
25P *	2.50"	18"	12.6" (32.0cm)
30P *	3.00"	18"	12.6" (32.0cm)
40P *	4.00"	18"	13.1" (33.3cm)

* Also available in A106 Grade B carbon steel pipe (20PC, 25PC, 30PC, and 40PC model codes)

Appendices

Fig. 7.6: Inline Remote Meter with 316 Stainless Steel Flow Body and NPT End Connections Dimensions

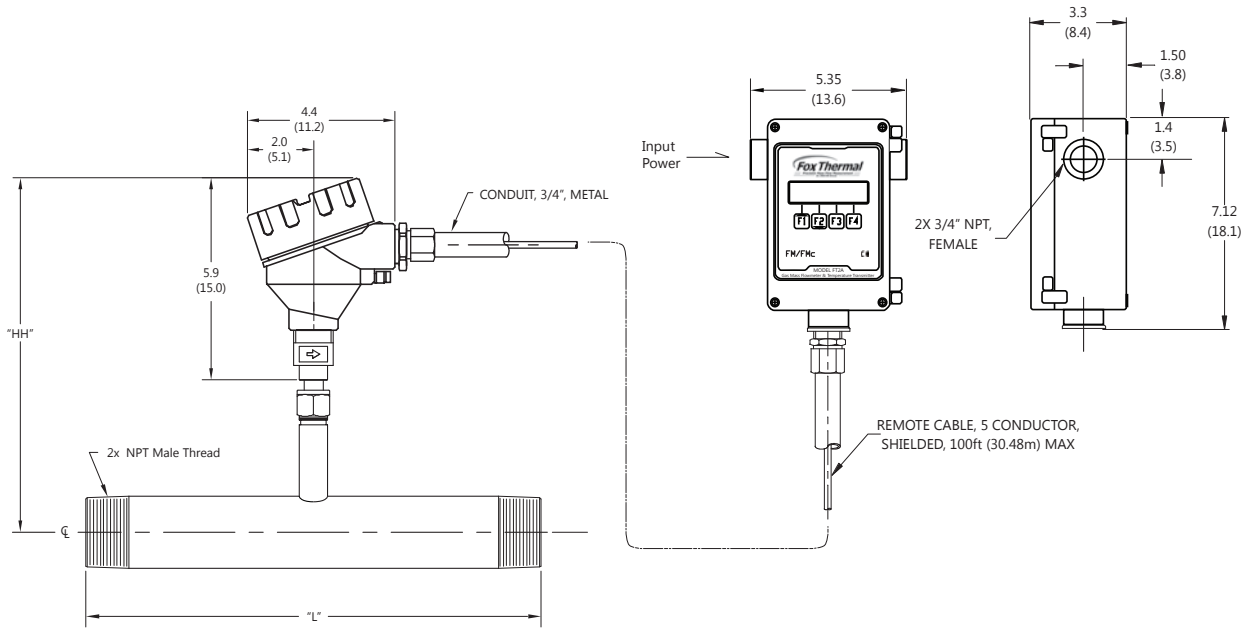

Table 7.6 Inline Remote Meter with 316 stainless steel flow body and NPT End Connections

Body Size [model code]	Body Size [inches]	Dimension "L" ± .10 [inches]	Dimension "HH" ± .25 [inches / centimeters]
025P	0.25"	5.8	9.9" (25.1cm)
05P	0.50"	12"	9.9" (25.1cm)
075P	0.75"	12"	9.9" (25.1cm)
10P	1.00"	12"	9.9" (25.1cm)
125P	1.25"	12"	9.9" (25.1cm)
15P	1.50"	12"	9.9" (25.1cm)
20P *	2.00"	12"	9.9" (25.1cm)
25P *	2.25"	18"	10.0" (25.4cm)
30P *	3.00"	18"	10.0" (25.4cm)
40P *	4.00"	18"	10.5" (26.7cm)

* Also available in A106 Grade B carbon steel pipe (20PC, 25PC, 30PC, and 40PC model codes)

Appendices

Fig. 7.7: Inline Meter with 316 Stainless Steel Flow Body and 150lb. RF Flange End Connections Dimensions

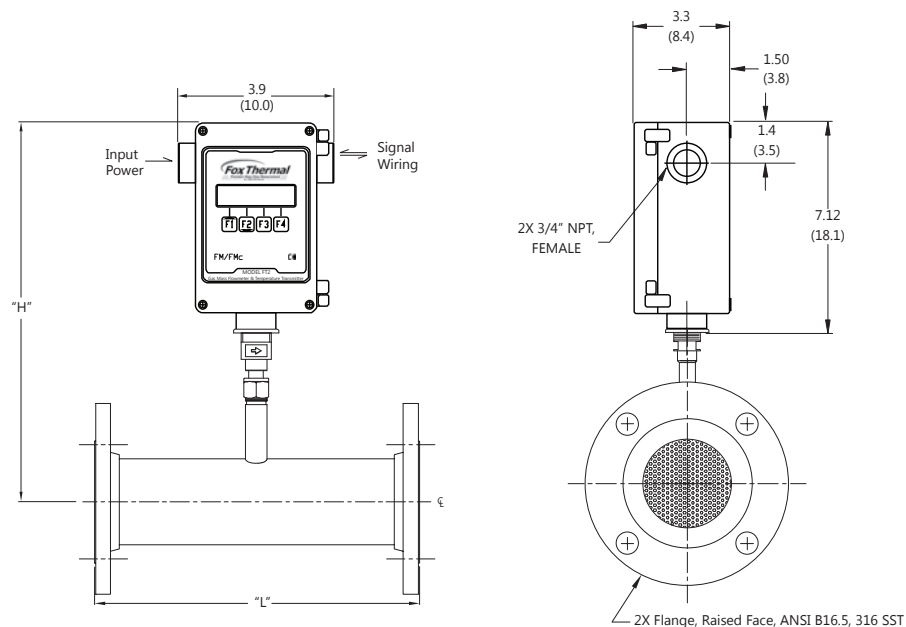

Table 7.7 Inline Meter with 316 stainless steel flow body and 150lb. RF Flange End Connections

Body Size [model code]	Body Size [inches]	Dimension "L" ± .10 [inches]	Dimension "H" ± .25 [inches / centimeters]
05F	0.50"	12"	12.5" (31.8cm)
075F	0.75"	12"	12.5" (31.8cm)
10F	1.00"	12"	12.5" (31.8cm)
125F	1.25"	12"	12.5" (31.8cm)
15F	1.50"	12"	12.5" (31.8cm)
20F *	2.00"	12"	12.5" (31.8cm)
25F *	2.50"	18"	12.6" (32.0cm)
30F *	3.00"	18"	12.6" (32.0cm)
40F *	4.00"	18"	13.1" (33.3cm)
60F	6.00"	24"	14.2" (36.1cm)

* Also available in A106 Grade B carbon steel pipe with A105 flanges (20FC, 25FC, 30FC, and 40FC model codes)

Appendices

Fig. 7.8: Inline Remote Meter with Stainless Steel Flow Body and 150lb. RF Flange End Connections Dimensions

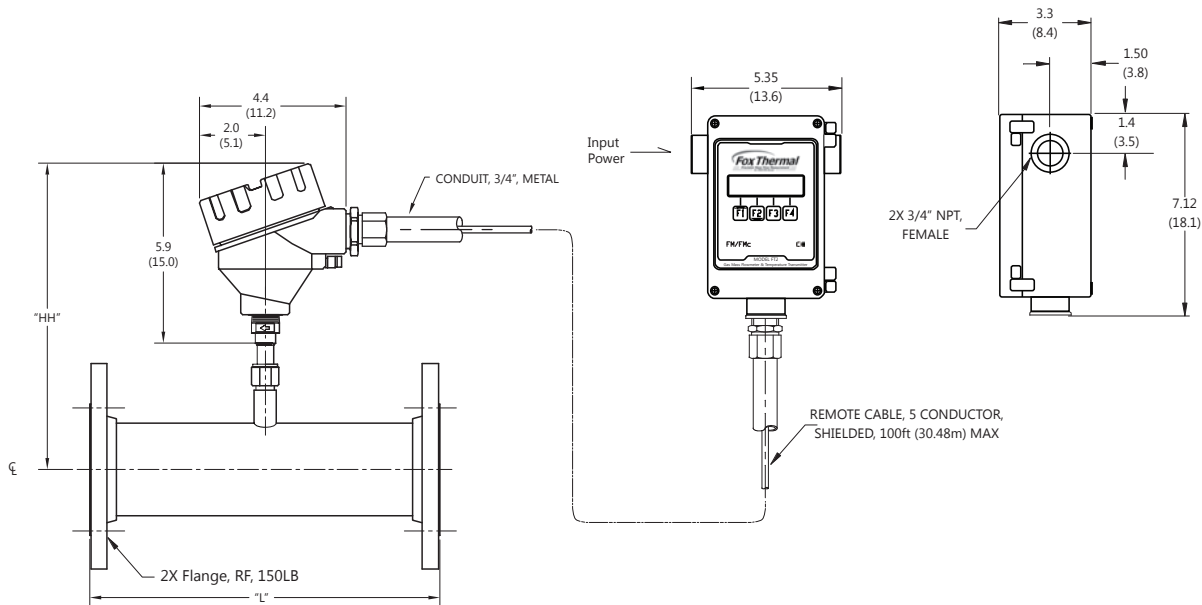

Table 7.8 Inline Remote Meter with stainless steel flow body and 150lb. RF Flange End Connections

Body Size [model code]	Body Size [inches]	Dimension "L" ± .10 [inches]	Dimension "HH" ± .25 [inches / centimeters]
05F	0.50"	12"	9.9" (25.1cm)
075F	0.75"	12"	9.9" (25.1cm)
10F	1.00"	12"	9.9" (25.1cm)
125F	1.25"	12"	9.9" (25.1cm)
15F	1.50"	12"	9.9" (25.1cm)
20F *	2.00"	12"	9.9" (25.1cm)
25F *	2.50"	18"	10.0" (25.4cm)
30F *	3.00"	18"	10.0" (25.4cm)
40F *	4.00"	18"	10.5" (26.7cm)
60F	6.00"	24"	11.6" (29.5cm)

* Also available in A106 Grade B carbon steel pipe with A105 flanges (20FC, 25FC, 30FC, and 40FC model codes)

Appendices

Mounting the FT2A Enclosure

When restricted physical installation space exists, the FT2A enclosure can be mounted in a location away from the remote sensor. Use the dimensional diagram below to help mount the enclosure properly.

Fig. 7.9: Rear of FT2A Enclosure Showing Mounting Pattern

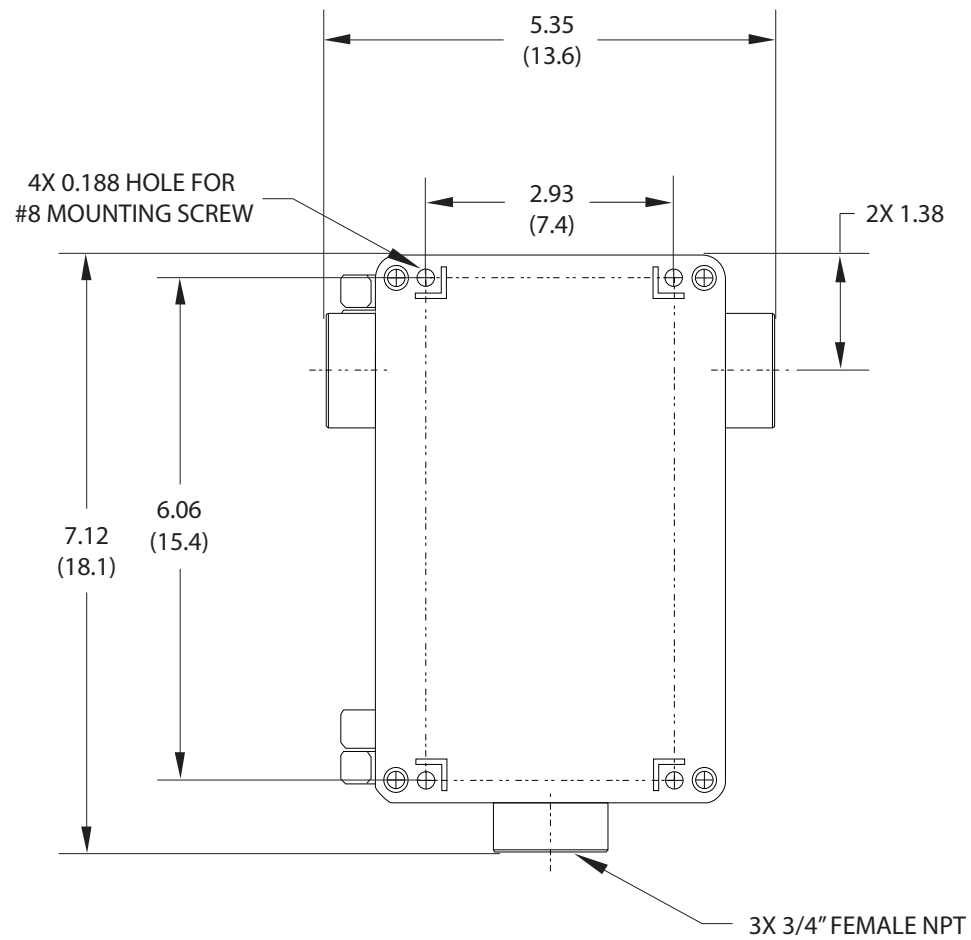

Figure 7.9 shows the rear view of the FT2A enclosure without sensor or conduit. AC power enters on one side, DC power and signals enter on either side.

Appendices

Mounting Bracket for the Model FT2A

A Fox Model FT2A Mounting Kit can be ordered at any time. The kit includes a mounting bracket with mounting screws and U-bolts. The bracket has been designed specifically to allow easy mounting of the FT2A to a surface. See Fig. 7.10 for dimensions.

Fig. 7.10: Model FT2A Mounting Kit

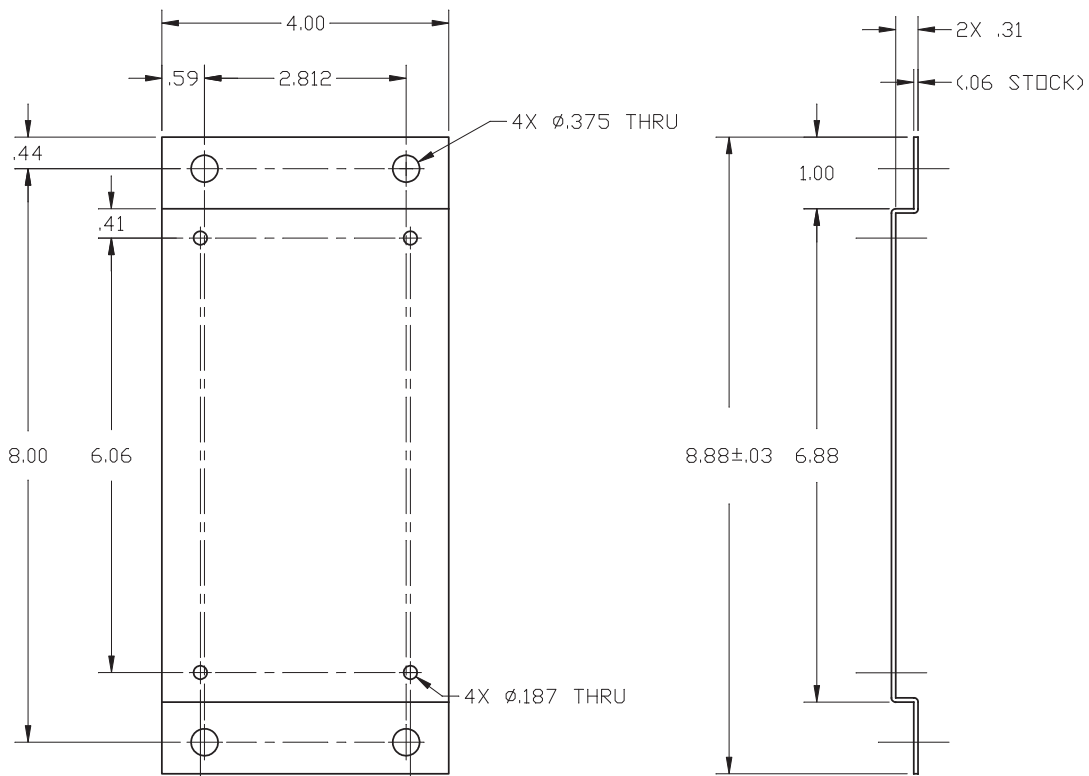

Appendices

Warranty

- (a) FOX warrants that the products furnished under this Agreement will be free from defects in material and workmanship for a period of one year from the date of shipment. The customer shall provide notice of any defect to FOX, within one week after the Customer's discovery of such defect. The sole obligation and liability of FOX, under this warranty shall be repair or replace, at its option, without cost to the Customer, the defective product or part.
- (b) Upon request by FOX, the product or part claimed to be defective shall immediately be returned at the Customer's expense to FOX. Replaced or repaired products or parts will be shipped to the Customer at the expense of FOX. FOX shall have the right of final determination as to the existence and cause of defect.
- (c) There shall be no warranty or liability for any products or parts that have been subject to misuse, accident, negligence, failure of electric power or modifications by the Customer without the written approval of FOX. Final determination of warranty eligibility shall be made by FOX. If a warranty claim is considered invalid for any reason, the Customer will be charged for services performed and expenses incurred by FOX, in handling and shipping the returned unit.
- (d) The liability of FOX shall be limited to replacing or repairing, at its option, any defective parts which are returned. Labor and related expenses incurred to install replacement parts are not covered by this warranty.
- (e) As to replacement parts supplied or repairs made during the original warranty period, the warranty period for the replacement or repaired part shall terminate with the termination of the warranty period of the original product or part.
- (f) The use of these products is under exclusive control of the purchaser and FOX specifically denies any responsibility for the calibration of units and/or accuracy of work performed or the safety of the system in which FOX products is used. EXTERNAL SAFETY DEVICES MUST BE USED WITH THIS EQUIPMENT.
- (g) No warranty is made with respect to custom equipment or products produced to Buyer's specifications except as specifically stated in writing by FOX and contained in the agreement.
- (h) THE FOREGOING WARRANTY CONSTITUTES THE SOLE LIABILITY OF FOX, AND THE CUSTOMER'S SOLE REMEDY WITH RESPECT TO THE PRODUCTS AND IS IN LIEU OF ALL OTHER WARRANTIES, INCLUDING ANY WARRANTY OF MERCHANTABILITY OR FITNESS FOR A PARTICULAR PURPOSE, LIABILITIES, AND REMEDIES. EXCEPT AS THUS PROVIDED, FOX, DISCLAIMS ALL WARRANTIES, EXPRESS OR IMPLIED, INCLUDING ANY WARRANTY OF MERCHANTABILITY OR FITNESS FOR A PARTICULAR PURPOSE.

Appendices

Returning Your Meter

The Fox Thermal Customer Service Department (PH: 831-384-4300 or FAX: 831-337-5787) can help you through the process of returning a meter for service.

If it becomes necessary to return a Fox flow meter for service or recalibration, please follow these steps:

1. A Return Material Authorization (RMA) Number must be obtained from the Fox Customer Service Department prior to returning any Fox meter(s).
2. Please have your meter's serial number(s) available.
3. Read and complete the Fox RMA Customer Information Form. Be sure to initial the decontamination statement as well as provide complete return shipping instructions (we cannot deliver to post office boxes).
4. The entire flow meter must be returned, including all electronics (unless specifically instructed to do otherwise). **ALL** serial numbers must match their corresponding meters. This is especially necessary when returning remote and/or flow body models.
5. Clean and decontaminate all wetted parts before returning to Fox.
6. Ship the meter to the following address:

Fox Thermal
399 Reservation Road
Marina, CA 93933
Attn: Service Dept.
[RMA Number]



NOTE! Be sure to review all of the information on the Customer Information Form before sending your meter to the Fox Customer Service Department. The Fox Shipping/Receiving Department cannot accept meters that have not been prepared appropriately.

What to expect while your meter is being serviced

Depending on the type of service required when returning your Fox meter, there are varying turnover times for servicing a meter. The average time needed to service the meter is 7-10 days (not including shipping or peak production times).

If you have already shipped your meter to Fox for servicing and would like to check the status of your meter, please fill out our online Service Order Status form located at www.foxthermal.com and you will hear from a Customer Service Rep within 1 business day of your requested update.

Rush recalibration service is available for a fee. Restrictions apply.

Glossary of Terms and Definitions

AC	Alternating Current
AWG	American Wire Gauge
Bara	Bar absolute
CTC	Contact
CAL	Calibration
CHG	Change
COM	Communication
CSV	Current Sense Voltage
DC	Direct Current
DN	Down
DSP	Display
ELP	Elapsed time
Feq	Frequency
Ft ²	Square Feet
I/O	Input/Output
INP	Input
IR	Infrared (IR Buttons = optical switches)
LB	Pound
LB/D	Pound per Day
LB/H	Pound per Hour
LB/M	Pound per Minute
LB/S	Pound per Second
LCD	Liquid Crystal Display
KG	Kilogram
KG/H	Kilogram per Hour
KG/M	Kilogram per Minute
KG/S	Kilogram per Second
M ²	Square Meter
mmHG	Pressure in millimeters of mercury
MMSCFD	Million Standard Cubic Feet per Day
MXFLO	Maximum Flow
NEMA	National Electrical Manufacturers Association
NIST	National Institute of Standards and Technology
NLP	Normal Liter
NLPH	Normal Liter per Hour
NLPM	Normal Liter per Minute
NM3	Normal cubic Meter
NM3/H	Normal cubic Meter per Hour
NM3/M	Normal cubic Meter per Minute

Definitions

NPT	National Pipe Thread
PDA	Personal hand held computer
UNT	Unit
U/P	Unit per Pulse
PC	Personal Computer
P/U	Pulse per Unit
PIP A ²	Pipe Area
PLC	Programmable Logic Controller
PRM	Parameters
PRS	Pressure
PSIA	Pounds per Square Inch Absolute
Pt	Point
PSW	Password
SIM	Simulation
SCF	Standard Cubic Feet
SCFM	Standard Cubic Feet per Minute
SCFH	Standard Cubic Feet per Hour
SCFD	Standard Cubic Feet per Day
SPC	Special Control
STP	Standard Temperature and Pressure
TMP	Temperature
TSI	Internal Variable
TSV	Internal Variable
420	4-20mA output

Index

Index

Access to Electronics, p. 20
 Alarm Codes, p. 72
 Analog 4-20mA outputs, p. 36
 Breakage or Damage of Probe, p. 62
 Calibration Parameters, p. 50
 Dimension Details,
 Local Inline Flange, p. 88
 Local Inline NPT, p. 86
 Local Insertion, p. 84
 Local with Retractor, p. 82
 Remote Insertion, p. 85
 Remote Inline NPT, p. 87
 Remote Inline Flange, p. 89
 Remote with Retractor, p. 83
 Discrete I/O, p. 7, p. 40, p. 40
 Discrete input settings, p. 40
 Discrete output setting, p. 40
 Display Screens, p. 33
 Display Setup, p. 41
 Engineering Screens, p. 34
 Entering the programming mode, p. 35
 Equal length sensors, p. 14
 Filter value, p. 48
 Flow Units, p. 44
 Frequency / Alarm Output Wiring, p. 28
 Frequency Output, p. 38
 Fuse Replacement, p. 62
 Input wiring - Remote, p. 23, p. 24
 Input wiring - Local, p. 20
 Installation,
 Compression Fitting, p. 15
 General Precautions, p. 9
 Introduction, p. 6
 Level 2 password, p. 43
 Local Display, p. 8
 Local Input Wiring, p. 23
 Mass Flow, p. 6
 Measurement Mode, p. 33
 Menu Trees,
 Digital Output, p. 55
 Display Menu, p. 58
 Engineering Display, p. 59
 Main Menu, p. 54
 Parameter Menu 1, p. 56
 Parameter Menu 2, p. 57

Password

Level 1, p. 43
 Level 2, p. 43
 Programming, p. 43

Power Input Wiring, p. 23**Preventative Maintenance, p. 62****Product Description, p. 6****Programming**

Analog 4-20mA Output, p. 36
 Alarm Output, p. 40
 Calibration Parameters, p. 50
 Changing values or strings, p. 35
 Discrete Input, p. 40
 Display Setup, p. 41
 Filter value, p. 48
 Flow cutoff, p. 47
 Flow Parameters, p. 46
 Flow and maximum frequency, p. 39
 High Alarm Limit value, p. 48
 Frequency Output, p. 38
 Low Alarm Limit value, p. 49
 Password, p. 43
 Pipe Area, p. 47
 Programming Mode, p. 35
 Pulse-per-unit, p. 39
 Reset Total & Elapsed Time, p. 50
 Restore Database, p. 51
 Reset CRC, p. 52
 Selecting from a list, p. 35
 Serial Communication, p. 41
 Simulation, p. 52
 Unit-per-pulse, p. 39
 Unit settings, p. 44
 Using the Local Display, p. 35

Remote Wiring Installation, p. 21**Replacements Fuses, p. 62****Reset Total and Elapsed Time, p. 50****Restore Database, p. 51****Return Procedure, p. 93****Scope, p. 9****Sensor Cleaning, p. 62****Sensor Orientation - Insertion meters, p. 13****Signal wiring, p. 25****Simulation Mode, p. 52****Theory of Operation, p. 6****To program the display, p. 42****Totalizer Rollover, p. 51**

Index

- Troubleshooting, p. 71**
 - Alarm Codes, p. 72**
 - General, p. 68**
 - Installation Problems, p. 71**
- Unequal length sensors, p. 14**
- USB Interface, p. 32**
- Warranty, p. 92**
- Wiring**
 - Alarms, p. 28**
 - Frequency/Alarm Outputs, p. 28**
 - Grounding, p. 20**
 - Input - Local, p. 23**
 - Input - Remote, p. 21**
 - Instructions, p. 20**
 - Local meters, p. 23**
 - Power Input, p. 23**
 - Precautions, p. 20**
 - Remote meters, p. 21**



Wiring



Definition of Terms



Troubleshooting Tips



Information



**Caution - (refer to accompanying documents):
Please follow the specified instructions and
general safety practices.**



**Indicates compliance with the WEEE Directive.
Please dispose of the product in accordance with
local regulations and conventions.**



**Indicates compliance with the applicable European
Union Directives for Safety LVD (Low Voltage
Directive 2006/95/EC), EMC (Electromagnetic
Compatibility Directive 2004/108/EC), and PED
(Pressure Equipment Directive 97/23/EC).**