

Panasonic[®]

Important Information

Network Camera

Model No. **WV-X6533LN, WV-S6532LN**

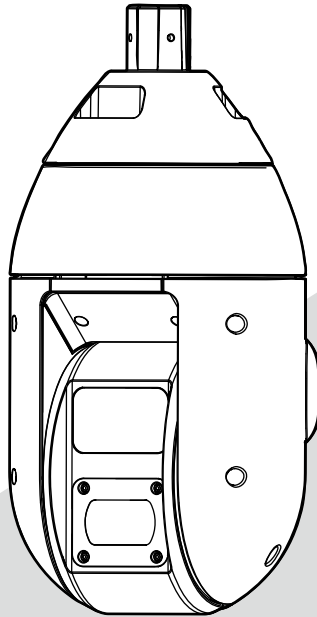

WV-X6533LN

* For information about the installation tasks, refer to the provided Installation Guide. For information about how to perform the settings and how to operate the camera, refer to the Operating Instructions on the following Panasonic support website.

<https://security.panasonic.com/download/>



Before attempting to connect or operate this product, please read these instructions carefully and save this manual for future use.

The model number is abbreviated in some descriptions in this manual.

Contents

Limitation of liability.....	3
Disclaimer of warranty.....	3
Preface	4
About notations.....	4
Main functions.....	4
About the user manuals	6
System requirements for a PC	6
Trademarks and registered trademarks.....	7
Open Source Software	7
Copyright.....	8
Network security	8
Precautions	9
Precautions for installation.....	14
Parts and functions	17
Insert/remove an SD memory card*	25
Troubleshooting.....	28
Specifications.....	32
Optional accessories.....	38

* SDXC/SDHC/SD memory card is described as SD memory card.

Limitation of liability

THIS PUBLICATION IS PROVIDED "AS IS" WITHOUT WARRANTY OF ANY KIND, EITHER EXPRESS OR IMPLIED, INCLUDING BUT NOT LIMITED TO, THE IMPLIED WARRANTIES OF MERCHANTABILITY, FITNESS FOR ANY PARTICULAR PURPOSE, OR NON-INFRINGEMENT OF THE THIRD PARTY'S RIGHT.

THIS PUBLICATION COULD INCLUDE TECHNICAL INACCURACIES OR TYPOGRAPHICAL ERRORS. CHANGES ARE ADDED TO THE INFORMATION HEREIN, AT ANY TIME, FOR THE IMPROVEMENTS OF THIS PUBLICATION AND/OR THE CORRESPONDING PRODUCT (S).

Disclaimer of warranty

IN NO EVENT SHALL Panasonic Corporation BE LIABLE TO ANY PARTY OR ANY PERSON, EXCEPT FOR REPLACEMENT OR REASONABLE MAINTENANCE OF THE PRODUCT, FOR THE CASES, INCLUDING BUT NOT LIMITED TO BELOW:

- (1) ANY LOSS OR DAMAGE, INCLUDING WITHOUT LIMITATION, DIRECT OR INDIRECT, SPECIAL, CONSEQUENTIAL OR EXEMPLARY, ARISING OUT OF OR RELATING TO THE PRODUCT;
- (2) ANY INCONVENIENCE, LOSS, OR DAMAGE CAUSED BY INAPPROPRIATE USE OR NEGLIGENT OPERATION OF THE USER;
- (3) ALL MALFUNCTIONS OR TROUBLES FROM UNAUTHORIZED DISASSEMBLE, REPAIR OR MODIFICATION OF THE PRODUCT BY THE USER, REGARDLESS OF THE CAUSE OF THE MALFUNCTION OR TROUBLE;
- (4) INCONVENIENCE OR ANY LOSS ARISING WHEN IMAGES ARE NOT DISPLAYED, DUE TO ANY REASON OR CAUSE INCLUDING ANY FAILURE OR PROBLEM OF THE PRODUCT;
- (5) ANY PROBLEM, CONSEQUENTIAL INCONVENIENCE, OR LOSS OR DAMAGE, ARISING OUT OF THE SYSTEM COMBINED BY THE DEVICES OF THIRD PARTY;
- (6) ANY CLAIM OR ACTION FOR DAMAGES BROUGHT BY ANY PERSON OR ORGANIZATION AS A PHOTOGRAPHED SUBJECT DUE TO VIOLATION OF PRIVACY CONCERNING A SURVEILLANCE CAMERA'S PICTURE OR SAVED DATA, FOR SOME REASON (INCLUDING USE WHEN USER AUTHENTICATION ON THE AUTHENTICATION SETTING SCREEN IS SET TO OFF), BECOMING PUBLIC OR BEING USED FOR ANY PURPOSE;
- (7) LOSS OF REGISTERED DATA CAUSED BY ANY FAILURE (INCLUDING INITIALIZATION OF THE PRODUCT DUE TO FORGOTTEN AUTHENTICATION INFORMATION SUCH AS A USER NAME AND PASSWORD).

Preface

This product is an outdoor use PTZ (PAN, TILT, ZOOM) network camera with a 10BASE-T/100BASE-TX network port for network connection.

By connecting to a network (LAN) or the Internet, images and audio from the camera can be monitored on a PC via a network.

Note:

- It is necessary to configure the network settings of the PC and its network environment to monitor images from the camera on the PC. It is also necessary to install a web browser on the PC.
-

About notations

The following notations are used when describing the functions limited for specified models. The functions without the notations are supported by all models.

X6533 The functions with this notation are available when using the model WV-X6533LN.

S6532 The functions with this notation are available when using the model WV-S6532LN.

Main functions

40x optical zoom **X6533 , 22x optical zoom **S6532** and the high accuracy preset position function that uses a gear drive**

Enables monitoring of a wide area using a single camera, and reduces the maintenance cost because of the use of a gear drive with a high durability.

High performance IR LED light and visible light cutoff filter are installed

With the high performance IR LED light, it is possible to record in the night a distance of 350m {Approx. 1150 ft}*1 **X6533** / 100m {Approx. 330 ft} **S6532** . Further, the visible light cutoff filter can reduce defocussing and blown out whites are reduced during infrared record.

Stabilizer using gyro sensor and image vector detection adopted **X6533**

Intelligent Zoom Stabilization using a gyro sensor and image vector detection enables correcting low-frequency vibration of the poles caused by wind or fine vibration generated when high magnification is set, and shooting with less blurring can be achieved.

Refer to “Stabilizer” of Operating Instructions for descriptions of how to set Intelligent Zoom Stabilization.

ClearSight coating (rain wash coating)*2 for front panel adopted

The rain wash coating is a special coating applied to the surface of the front panel that makes it difficult for water droplets to adhere to the front panel.

The camera conforms to the IP66*³ and Type 4X (UL50E)*⁴, is compliant with NEMA 4X*⁵ ratings, and provides high dust resistance and waterproof performance.

Waterproofing treatment is not required for the camera body (Waterproofing treatment is required for all cable connection parts except for Ethernet cable).

Achieves high-level shock resistance with IK10*⁶ (IEC 62262) conformity.

The camera has a strong shock resistance body which is needed in outdoor installations.

Delivers high image quality streaming at low bit rates thanks to a H.265 engine equipped with Panasonic's own Smart Facial Coding technology*⁷.

This allows H.265 compression in addition to conventional H.264 compression technology, and when combined with Smart Facial Coding, reduces data load compared to our previous models.

Panasonic's own intelligent auto (iA) feature provides increased discernibility even in environments with poor visibility

Improvements to the Super Dynamic (SD) feature and shutter speed optimization provides clear discernibility even when monitoring moving people or car silhouettes or when license plates are illuminated by car headlights. Also, face recognition under the condition where brightness of the background changes is enabled by a function of recognizing face position and adjusting the brightness automatically.

Equipped with SD slot

It is possible to save H.265 / H.264 videos and JPEG images on the SD memory card manually when an alarm occurs, during the period of the schedule, or on a Web browser. (Downloading is possible.) It is also possible to save JPEG images if a network failure occurs.

Encryption and alteration detection functions enhanced the security.

*1 When using a 24V AC power supply or the tested PoE injector. The irradiation distance is 150m {Approx. 500 ft} when PoE+ device is used. For the latest information about the tested PoE injector, refer to our website (<https://security.panasonic.com/support/info/> <Control No.: C0116>).

*2 The rain wash coating is only effective against water (rain water) and is not effective against other substances such as oil or damage to the front panel.

*3 IP66: The applicable product has "Dust tight (6)" protection against foreign solids and has "Powerful water jets (6)" protection against water (IEC 60529).

*4 Type 4X (UL50E): 4X indicates the rank in the UL waterproof standard.

*5 NEMA 4X: Dust resistance and waterproof performance standards set by National Electrical Manufacturers Association (United States).

*6 IK10: is a standard in regards to shock resistance that represents the level of impact protection, and is regulated by the International Electrotechnical Commission (IEC).

*7 This technology allows the camera to learn the location of faces and moving objects, and transmit only the face portion of the image in high definition, thereby greatly reducing the bandwidth required.

About the user manuals

Product documentation is composed of the following documents.

- **Important Information (this document):** Provides basic information about the product such as Precautions for installation, Parts and functions, etc..
- **Installation Guide:** Explains installation, mounting, cable connections, and network connections.
- **Operating Instructions (on the Panasonic support website):** Explains how to perform the settings and how to operate this camera.

"<Control No.: C****>" used in this document should be used to search for information on the Panasonic support website and will guide you to the right information.

Note:

- The external appearance and other parts shown in this manual may differ from the actual product within the scope that will not interfere with normal use due to improvement of the product.
-

System requirements for a PC

CPU:	Intel® Core™ Processor family *1 - Intel® Core™ i5-6500 or faster - Intel® Core™ i7-6700 or faster recommended
Memory:	4 GB (2 GB x 2, Dual Channel) or more recommended.
Network interface:	10BASE-T/100BASE-TX 1 port
Audio interface:	Sound card (when using the audio function)
Monitor:	Image capture size: 1024 x 768 pixels or more Color: 24-bit True color or better
OS:	Microsoft Windows 10 Microsoft Windows 8.1 Microsoft Windows 7
Web browser:	Internet Explorer 11 (32-bit)
Others:	CD-ROM drive (It is necessary to read the several kind of operating instructions and use the software on the provided CD-ROM.) Adobe® Reader® or Acrobat® Reader® (It is necessary to view the PDF file.)

*1 For details on using the hardware decode function, refer to our website ([https://security.panasonic.com/support/info/ <Control No.: C0313>](https://security.panasonic.com/support/info/<Control No.: C0313>)).

IMPORTANT:

- For information on the operation verification of the supported operating systems and web browsers, refer to our website at <https://security.panasonic.com/support/info/> <Control No.: C0104>.
 - When using a PC that does not meet the above requirements, displaying of images may become slower or the web browser may become inoperable.
 - Audio may not be heard if a sound card is not installed on a PC. Audio may be interrupted depending on the network environment.
 - Microsoft Windows RT, Microsoft Windows 7 Starter and Microsoft Edge are not supported.
 - When using Microsoft Windows 8.1, use it in the desktop. The software cannot be used in the Modern UI design.
-

Note:

- For further information about PC system requirements and precautions for when using Microsoft Windows or Internet Explorer, click “Manual” - “Open” from the supplied CD-ROM and refer to “Notes on Windows / Internet Explorer versions”.
-

Trademarks and registered trademarks

- Microsoft, Windows, Windows Media, Internet Explorer, and ActiveX are either registered trademarks or trademarks of Microsoft Corporation in the United States and/or other countries.
- Microsoft product screen shot(s) reprinted with permission from Microsoft Corporation.
- Intel and Intel Core are trademarks of Intel Corporation or its subsidiaries in the U.S. and/or other countries.
- Adobe, Acrobat, and Reader are either registered trademarks or trademarks of Adobe in the United States and/or other countries.
- SDXC Logo is a trademark of SD-3C, LLC.
- iPad and iPhone are trademarks of Apple Inc., registered in the U.S. and other countries.
- Android is a trademark of Google LLC.
- Firefox is a trademark of the Mozilla Foundation in the US and other countries.
- The word “QR Code” is a registered trademark of DENSO WAVE INCORPORATED in Japan and other countries.
- All other trademarks identified herein are the property of their respective owners.

Open Source Software

- This product contains open source software licensed under GPL (GNU General Public License), LGPL (GNU Lesser General Public License), etc.
- Customers can duplicate, distribute and modify the source code of the software under license of GPL and/or LGPL.
- Refer to the “readme.txt” file on the provided CD-ROM for further information about open source software licenses and the source code.
- Please note that Panasonic shall not respond to any inquiries regarding the contents of the source code.

Copyright

Except for open source software licensed under GPL/LGPL and so on, distributing, copying, disassembling, reverse compiling and reverse engineering of the software provided with this product are all expressly prohibited. In addition, exporting any software provided with this product violating export laws is prohibited.

Network security

As you will use this unit connected to a network, your attention is called to the following security risks.

- ① Leakage or theft of information through this unit
- ② Use of this unit for illegal operations by persons with malicious intent
- ③ Interference with or stoppage of this unit by persons with malicious intent

It is your responsibility to take precautions such as those described below to protect yourself against the above network security risks.

- Use this unit in a network secured by a firewall, etc.
- If this unit is connected to a network that includes PCs, make sure that the system is not infected by computer viruses or other malicious entities (using a regularly updated anti-virus program, anti-spyware program, etc.).
- To prevent unauthorized access, use user-authentication, set user names and passwords, and limit which users can log in.
- Apply measures such as user authentication to protect your network against leakage or theft of information, including image data, authentication information (user names and passwords), alarm mail information, FTP server information and DDNS server information.
- After the unit is accessed by the administrator, make sure to close the browser.
- Change the administrator password periodically. Additionally, save user authentication information (user names and passwords) in such a way that it is kept out of the hands of third parties.
- Do not install the camera in locations where the camera or the cables can be destroyed or damaged by persons with malicious intent.

Precautions

Do not insert any foreign objects.

Fire or electrical shock may be caused if water or any foreign objects, such as metal objects, enter inside the unit.

Turn the power off immediately and contact qualified service personnel for service.

Do not use this product in an inflammable atmosphere.

Failure to observe this may cause an explosion resulting in injury.

Avoid installing this product in the locations where salt damage occurs or corrosive gas is produced.

Otherwise, the mounting portions will deteriorate and accidents such as a fall of the product may occur.

Do not strike or give a strong shock to this product.

Failure to observe this may cause fire or injury.

Keep SDXC/SDHC/SD memory cards away from infants and children.

Otherwise, they may swallow the cards by mistake. In this case, consult a doctor immediately.

Do not hang down from this product or use this product as a pedestal.

Failure to observe this may cause a drop resulting in accidents.

Do not damage the power cable.

Do not damage, fabricate, twist, stretch, bundle, or forcibly bend the power cable. Do not place heavy objects on it, and keep it away from heat sources.

Use of a damaged power cable may cause electric shock, short circuit, or fire.

Consult the dealer for repair.

Do not touch the main body during the rotating operation.

Otherwise, your finger may get caught in the rotating unit, thus resulting in injury.

Do not install this product on a place that is greatly influenced by wind.

Installation on a place where the wind speed is 60 m/s {approx. 134 mph} or more may cause a fall of the product resulting in injury or accidents.

Do not sprinkle more water, exceeding the performance limit of waterproof with a high pressure cleaning machine, etc.

Fire or electrical shock may be caused by immersion.

Do not attempt to disassemble or modify this product.

Failure to observe this may cause fire or electric shock.

Consult the dealer for the repair or inspections.

Do not install or clean the camera, or touch this product, the power cable or the connected cables during thunder storms.

Failure to observe this may cause electric shock.

Refer installation work to the dealer.

Installation work requires technique and experience. Failure to observe this may cause fire, electric shock, injury, or damage to the product. Be sure to consult the dealer.

Stop the operation immediately when something is wrong with this product.

When smoke goes up from the product, the smell of smoke comes from the product, or the exterior of the product has deteriorated, continued use will cause a fire or fall of the product resulting in injury, or damage to the product. In this case, turn the power off immediately and contact qualified service personnel for service.

Select an installation area that can support the total weight.

Selecting an inappropriate installation surface may cause this product to fall down or topple over, resulting in injury or accidents. Installation work shall be started after sufficient reinforcement.

Periodic inspections shall be conducted.

Rust on the metal parts or screws may cause a fall of the product resulting in injury or accidents. Consult the dealer for the inspections.

The exclusively designed mount bracket shall be used.

Failure to observe this may cause a drop resulting in injury or accidents. Use the exclusively designed mount bracket for installation.

The screws and bolts must be tightened to the specified torque.

Failure to observe this may cause a drop resulting in injury or accidents.

Turn the power off when do wiring of this product.

Failure to observe this may cause electric shock. In addition, short circuit or wrong wiring may cause fire.

Install this product in a location high enough to avoid people and objects from bumping the product.

Failure to observe this may cause injury.

The measures of protection against a fall of this product shall be taken.

Failure to observe this may cause a drop resulting in injury or accidents. Be sure to install the safety wire.

Do not install this product in locations subject to vibration.

Loosening of mounting screws or bolts may cause a fall of the product resulting in injury or accidents.









: Caution, infrared radiation



: Direct current symbol



: Alternating current symbol

 CAUTION	 RISK GROUP 2
IR emitted from this product. Avoid eye exposure. Use appropriate shielding or eye protection.	
 ATTENTION	 GROUPE DE RISQUE 2
IR émis par ce produit. Éviter d'exposer les yeux. Utiliser un écran approprié.	
 注意	 リスクグループ 2
この製品から赤外線が放射されています。 赤外線を直視しないでください。適切なシールドまたは目の保護具を使用すること。	

Correctly perform all wiring

Short circuits in the wiring or incorrect wiring may cause fire or electrical shock.

The measures of protection against snow-fall shall be taken.

Weight of snow may cause a fall of the product resulting in injury or accidents. Protect the product against snowfall by installing it under eaves.

Turn the power off when cleaning this product.

Failure to observe this may cause electrical shock.

Install the product securely on a wall or a ceiling in accordance with the installation instructions.

Failure to observe this may cause injury or accidents.

Do not rub the edges of metal parts with your hand.

Failure to observe this may cause injury.

Do not look directly at the tip of optical connector, optical fiber (when using WV-X65F1 (Extension unit: optical I/F option unit)).

Failure to observe this may cause injury or accidents.

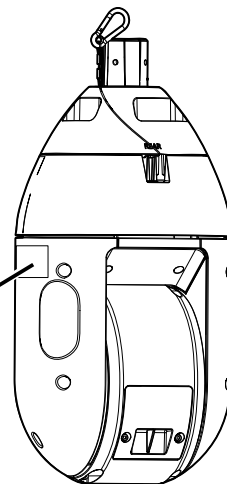

This illustration represents WV-X6533LN

[Precautions for use]

When the product is accessible from the Internet

To prevent unauthorized access, note the following.

- Leave user authentication turned on.
- Periodically change passwords that are used to access the product.

Refer to the Operating Instructions on the Panasonic support website for information about how to change passwords.

To keep on using with stable performance

Do not use this product in hot and humid conditions for a long time. Failure to observe this causes component degradation resulting in life shortening of this product. Do not expose this product to direct heat sources such as a heater.

This product has no power switch.

When turning off the power, disconnect the power supply from the 24 V AC power supply, the tested PoE injector or the PoE+ device.

Turning the power supply ON and OFF frequently can lead to malfunctions.

Handle this product with care.

Do not drop this product, nor apply shock or vibration to the product. Failure to observe this may cause trouble.

About the battery

A battery is installed inside the camera. Do not leave the battery exposed in environments of excessive heat as a result of sunlight or fire.

Do not subject the front panel to strong impact.

Doing so may cause damage or immersion.

Do not touch the front panel directly with your bare hands.

A dirty front panel causes deterioration of picture quality.

When an error is detected, this product will restart automatically.

This product will be inoperable for around 2 minutes after the restart just as when the power is turned on.

About the automatic status detection function

When this product malfunctions due to exogenous noise, etc. for 30 seconds or more, the product will automatically reset and will return to normal state. When the product is reset, initialization will be carried out as when the power of the product is turned on. When the product repeatedly resets, exogenous noise level around the product may be high and that may cause malfunction. Contact your dealer for instructions.

Periodically images on the screen appear to be distorted

When the camera is installed in a location where it is subject to small vibrations (for example, when it is installed near devices that vibrate), images may appear distorted and stretched lengthways. This phenomenon is a characteristic of image pickup devices that use CMOS sensors and is caused by the relationship between the periodic movements of the camera and the timing that the image sensor reads images. This is not a problem with the camera. To reduce the possibility of this phenomenon occurring, install the camera in a secure location.

What to do if “WARMING UP-PLEASE WAIT” appears on the display.

This message indicates that the temperature inside the camera has become extremely low. The camera will be automatically restarted when the inside the camera is warmed up by the built-in heater. Please wait for a while.

We shall not be liable for content compensation, losses of recorded or edited content and any direct or indirect consequent damages caused by failure to record or edit due to faults with this unit or the SD memory card. In addition, the same provisions apply after unit is repaired.

About the CMOS image sensor

- When continuously shooting a bright light source such as a spotlight, the color filter of the CMOS image sensor may become deteriorated and this may cause discoloration. Even when changing the fixed shooting direction after continuously shooting a spotlight for a certain period, the discoloration may remain.
- When shooting fast-moving subjects or performing panning/tilting operations, objects crossing the shooting area may look to be bending askew.

Cleaning this product body

Be sure to turn off the power before cleaning. Failure to observe this may cause injury. Do not use benzine, thinner, alcohol, or any other types of solvents or detergents. Otherwise, it may cause discoloration. When using a chemical cloth for cleaning, read the caution provided with the chemical cloth product.

- Do not loosen or remove screws unless instructed to do so in the product documentation.
- The camera position may be moved inadvertently while cleaning the camera body. Restart the product or refresh the camera position (position refresh) to correct the camera position. Refer to the Operating Instructions on the the Panasonic support website for further information.

Cleaning of the front panel

- When cleaning the front panel, hose or spray fresh water that is not containing lubricant agent or silicon substances and wash away adherents such as grain of sand. If dirt is hard to remove, use a sponge soaked into the fresh water mentioned above and wipe off.
- Do not wipe the cover with a dry cloth. (Using dry cloth may spread oil constituent adhered to the surface, and it may result in damaging the ClearSight coating (rain wash coating).)

- If dirt cannot be wiped off with a damp cloth, use a neutral detergent for kitchen utensils, and sufficiently rinse off the detergent.

When using a detergent containing wax components such as detergent for washing cars, a detergent with polishing material such as a compound, etc., and a non-neutral (weakly acidic or weakly alkaline) detergent, it can decrease the hydrophilic property and peel off the surface coating.

- Do not use organic solvent such as benzine and thinner.
- Before using a spray, abandon a few sprays to eliminate impurities.
- Improper cleaning of the front panel may cause the ClearSight coating (rain wash coating) to become less effective. In this case, in order to have effective ClearSight coating (rain wash coating), a new front panel must be purchased to replace the existing front panel. Consult with your dealer or construction contractor.

About the stabilizer function

Depending on the conditions in the installation area, effects of the stabilizer function may not be fully achieved.

Consumable parts

The following are consumables: Replace them in accordance with their operating lifetimes. Their operating lifetimes vary depending on the usage environment and conditions. The operating lifetimes below are just guides for when using the camera at +35 °C {95 °F}.

- Lens unit, panning motor, tilting motor: Approx. 3.7 million operations (Approx. 20000 hours)
Cooling fan: Approx. 52000 hours
Slip ring: Approx. 3.7 million operations (Approx. 20000 hours)
- When continuing the action of moving the set position for a long period, dust may accumulate in a slip ring. It can be prevented by executing the position refresh action regularly (about once a week) using the schedule setting.

AVC Patent Portfolio License

THIS PRODUCT IS LICENSED UNDER THE AVC PATENT PORTFOLIO LICENSE FOR THE PERSONAL USE OF A CONSUMER OR OTHER USES IN WHICH IT DOES NOT RECEIVE REMUNERATION TO (i) ENCODE VIDEO IN COMPLIANCE WITH THE AVC STANDARD (“AVC VIDEO”) AND/OR (ii) DECODE AVC VIDEO THAT WAS ENCODED BY A CONSUMER ENGAGED IN A PERSONAL ACTIVITY AND/OR WAS OBTAINED FROM A VIDEO PROVIDER LICENSED TO PROVIDE AVC VIDEO. NO LICENSE IS GRANTED OR SHALL BE IMPLIED FOR ANY OTHER USE. ADDITIONAL INFORMATION MAY BE OBTAINED FROM MPEG LA, L.L.C.
SEE [HTTP://WWW.MPEGLA.COM](http://www.mpegla.com)

Product disposal/transfer

Data saved on this product or a storage device used with this product may lead to personal information leakage. When it is necessary to dispose or give this product to someone, even when for repair, make sure that there is no data on this product.

When abandoning the memory media, it is recommended to destroy it physically after deleting data by PC.

Lens and pan/tilt head

If a lens and pan/tilt head are not performed for a long period of time, the grease coating inside these parts may become sticky. That may obstruct the parts from moving. To prevent this, move the lens or pan/tilt head periodically. Or perform position refresh periodically in the manner described in “Position refresh”.

Position refresh

During the use for a long period of time, the preset positions may become inaccurate. When “Position refresh” is set for the created schedule, the camera position will be corrected periodically. Refer to the Operating Instructions on the the Panasonic support website for how to perform the settings.

Equipment classification and power source indication label

Refer to the indication label inside the SD slot cover at the rear part of this unit for the equipment classification, power source, and other information.

Precautions for installation

Panasonic assumes no responsibility for injuries or property damage resulting from failures arising out of improper installation or operation inconsistent with this documentation.

For information about the installation tasks, refer to the provided Installation Guide.

In order to prevent injury, the product must be securely mounted to a wall or ceiling according to Installation Guide.

This equipment is not suitable for use in locations where children are likely to be present.

Mount the bracket higher than 3.0 m {9.84 feet} from the ground.

Power supply

This product has no power switch.

When performing electrical work, make sure the camera can be turned on and off. When an Ethernet cable or power cable is connected, the power is turned on. When the product is supplied, the product will perform panning, tilting, zooming and focusing.

When cleaning the product, remove the Ethernet cable or disconnect the power cable from the main power supply.

Installation area for this product

Select an appropriate place for the installation area (such as a strong wall or ceiling) in your particular environment.

- When hanging the camera from a ceiling, use the WV-Q121B (option) ceiling mount bracket.
- When installing on a wall, use wall mount bracket WV-Q122A (option).
- When pendant-mounting on a ceiling on a bracket that is custom-made, use the attachment pipe.
- Make sure that the installation area is strong enough to hold this product, such as a concrete ceiling.
- Install the camera in the foundation area of the architecture or where sufficient strength is assured.

- Do not mount the product on a plaster board or a wooden section because they are too weak. If the product is unavoidably mounted on such a section, the section shall be sufficiently reinforced.

When using the camera in combination with an attachment pipe and attaching to a locally procured bracket

- Locally procure a M6 eye bolt (stainless steel).
Minimum pull-out strength (per 1 pc.):
1411 N {317 lbf}
- In order to prevent the camera from falling, procure a bracket that can be attached a safety wire.
- Connect the M6 eye bolt and locally procured bracket together with the safety wire.
- Check that the surface that the attachment pipe and locally procured bracket are to be attached to can bear the weight of the bracket and camera.

Mounting method for this product

This product is designed to be used as a pendant mount camera. If the product is mounted on a desktop or at a slant, it may not work correctly and its lifetime may be shortened.

Do not place this product in the following places:

- Locations where a chemical agent is used such as a swimming pool
- Locations subject to moisture or oil smoke such as a kitchen
- Locations that have a specific environment that is subject to an inflammable atmosphere or solvents
- Locations where a radiation, an X-ray, a strong radio wave or a strong magnetic field is generated
- Locations near coasts directly subjected to sea breezes, or locations subject to corrosive gases such as from hot springs, volcanic regions, etc.
- Locations where the temperature is not within the specified range (☞ page 32)
- Locations subject to vibrations, such as on vehicles, marine vessels, or above product lines (This product is not designed for on-vehicle use.)
- Locations subject to condensation as the result of severe changes in temperature (In case of installing the product in such locations, the front panel may become foggy or condensation may be caused on the panel.)

Sulfurization caused by rubber products

Do not place the product near rubber products (packing, rubber feet, etc.) that contain sulfur. There is a risk that sulfur components in rubber products may cause electrical parts and terminals, etc. to become sulfurized and corrode.

Screw tightening

- The screws and bolts must be tightened with an appropriate tightening torque according to the material and strength of the installation area.
- Do not use an impact driver. Use of an impact driver may damage the screws or cause tightening excessively.
- When a screw is tightened, make the screw at a right angle to the surface. After tightening the screws or bolts, perform checks to ensure that the tightening is sufficient enough so that there is no movement or looseness.

Heater unit

This product is equipped with an internal heater unit for use in cold climates.

The heater unit turns on automatically when the temperature inside the product drops below +10 °C {50 °F}. When this product is installed and operated in low temperatures below -20 °C {-4 °F}, it may require time to start up since the camera will wait to be warmed up internally by the internal heater right after the power is turned on. Also, the camera may not function properly, if it is installed and operated in an environment where the temperature is below -30 °C {-22 °F}. In such a case, wait approximately 2 hours or more until the camera is warmed up. Then, turn on the power again. As the camera warms up, snow or frost accumulated on the front panel will melt. However, it may not be defrosted from the panel depending on the ambient temperature or weather condition.

When installing the product in cold climates

When using IR LED light in very cold regions, it is recommended to use along with an AC power supply or a tested PoE injector.

- The heater does not operate when using a PoE + device.

Effects on images and image quality

Under the following conditions, image quality may deteriorate or images may become difficult to see.

- When there are raindrops on the front panel due to wind during rainfall.
- When there is snow on the front panel due to wind during snowfall. (varies depending on the amount and quality of snowfall).
- When the front panel is dirty due to dust in the air or vehicle exhaust.

About reflection of light from outside or IR light

Depending on the incident angle of high intensity light source such as sunlight or lighting, images of non-existing objects (reflected light) or reflections of surroundings on the camera lens (ghost) may sometimes appear on the screen. Especially in the case of LED light, these phenomena may be seen remarkably. In the case of using the IR light, installation of a camera near a wall may cause reflection of infrared rays resulting in a part of the screen or the entire screen turning whitish. Therefore, consider the installation place carefully.

- Refer to our website (<https://security.panasonic.com/support/info/> <Control No.: C0109>) for image examples and measures to take.

Protection from lightning

When cables are used outdoors, there is a chance that they may be affected by lightning. In such a case, install a lightning arrester close to the camera, and make the length of the network cable between the camera and lightning arrester as short as possible to prevent the camera from being damaged by lightning.

Grounding connection of the lightning arrester

With the camera mount bracket connected to the earth ground, connect the ground of the lightning arrester (locally procured) to the following location of this unit. Procure locally all the screws used for connecting. Recommended fixing screws: M3×8 mm with spring washer

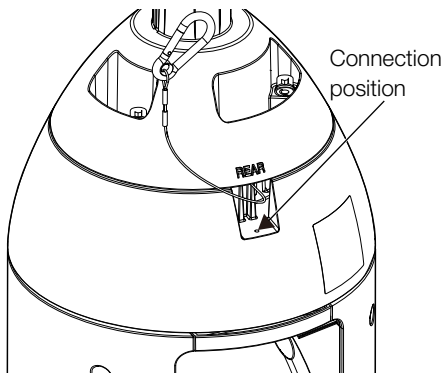

Take notice of humidity

Install this product when the humidity is low. If installation is performed when it is raining or in very humid conditions, the inside may be affected by humidity, causing mist-over inside the front panel.

When noise disturbance may happen

Conduct the power distribution work to keep a distance of 1 m {3.28 feet} or more from the 120 V (for U.S. and Canada) or 220 V – 240 V (for Europe and other countries) power line. Or conduct the electric conduit work separately (Always connect the metal pipe with grounding).

Radio disturbance

Noise may appear in video or audio near a strong electric field from a TV or radio antenna, motors and transformers, or a strong electric field/magnetic field from a power line (lamp line) of AC100 V or more.

PoE+ (Power over Ethernet Plus)

Use a PoE+ hub / device that is compliant with IEEE802.3at standard.

It is impossible to supply the power to this product from a PoE hub that is compliant with IEEE802.3af standard.

Router

When connecting this product to the Internet, use a broadband router with the port forwarding function (NAT, IP masquerade). Refer to the Operating Instructions on the Panasonic support website for further information about the port forwarding function.

Time & date setting

It is necessary to set the time & date before putting this product into operation. Refer to the Operating Instructions on the Panasonic support website for descriptions of how to perform the settings.

Make sure to remove this product if it will no longer be used.

Parts and functions

【Whole unit】

This illustration represents WV-X6533LN

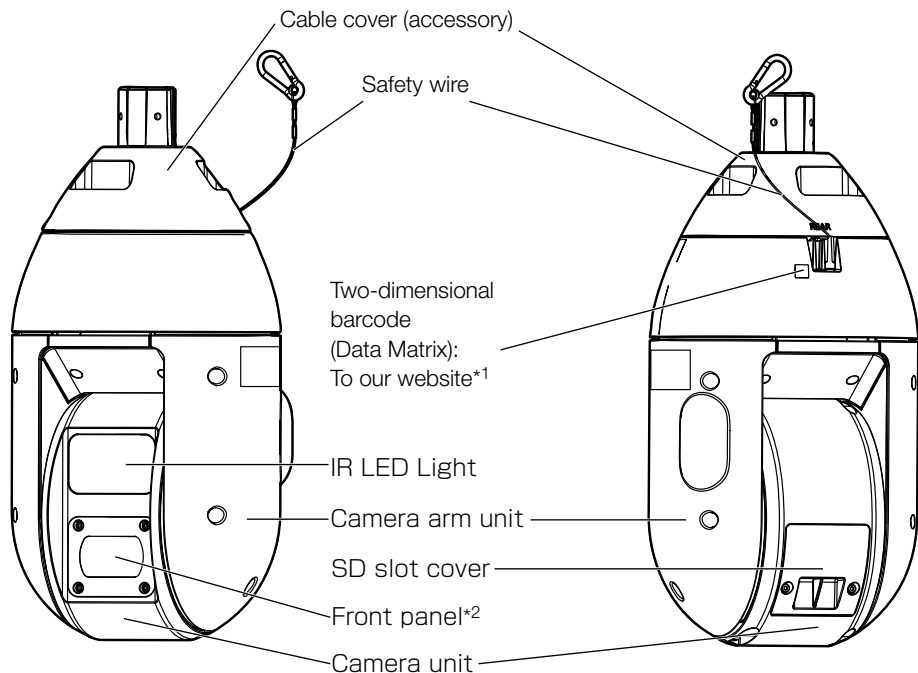

【SD slot cover portion】

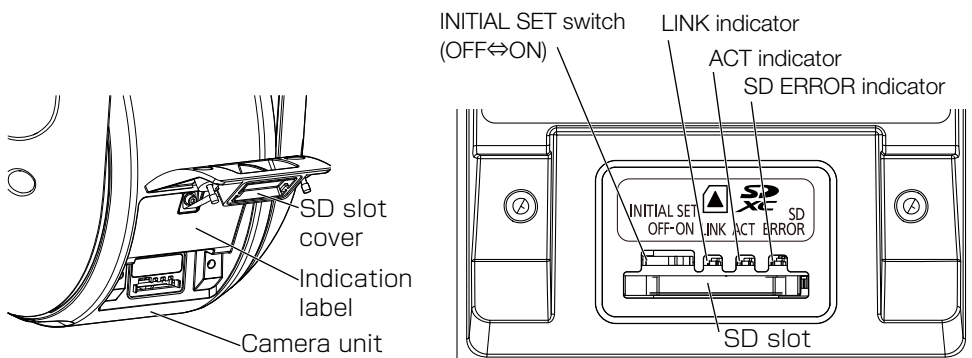

*1 Depending on the scanning application used, the Data Matrix may not be able to be read correctly. In this case, access the site by directly entering the following URL.
https://security.panasonic.com/support/qr_sp_select/

*2 Thin white radial impressions may appear in the surroundings of the front panel. These occur during the process of forming the rain wash coating and are not abnormalities in the product.

■ Cables

① RJ45 Network cable

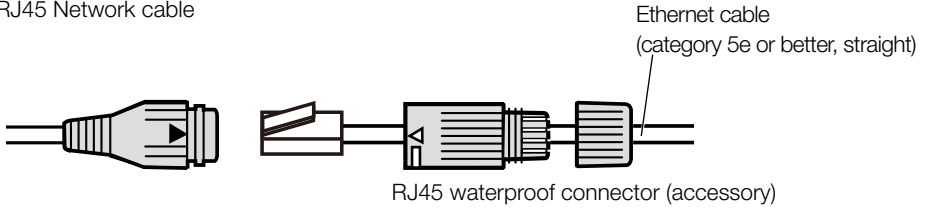

② Power supply terminal (24 V AC)

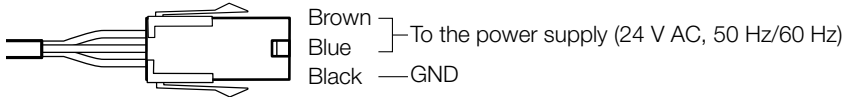

③ Audio input cable (white)

④ Audio output cable (black)

⑤ Alarm input/output cable

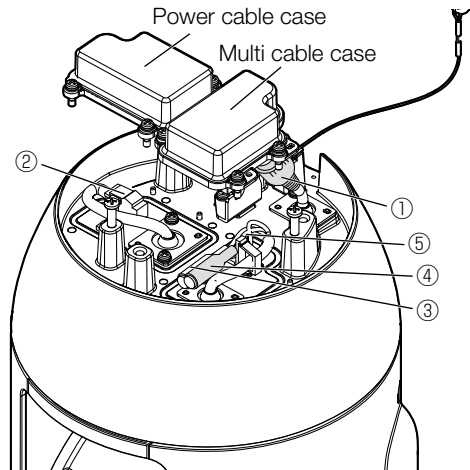
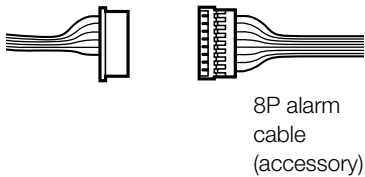

This illustration represents WV-X6533LN

① RJ45 (female) Network cable

Connect an Ethernet cable (category 5e or better, straight) to the network connector.

IMPORTANT:

- Use all 4 pairs (8 pins) of the Ethernet cable.
- The maximum length of the Ethernet cable (locally procured) is 100 m {Approx. 328 ft}.
- Make sure that the PoE+ device in use is compliant with IEEE802.3at standard.
- When connecting both the 24 V AC power supply and the PoE+ device for power supply, 24 V AC will be used for power supply.
- When the Ethernet cable is disconnected once, reconnect the cable after around 2 seconds. When the cable is quickly reconnected, the power may not be supplied from the PoE+ device.

② Power supply terminal (24 V AC) / 24 V AC power supply connector kit (accessory)

Caution:

- A READILY ACCESSIBLE DISCONNECT DEVICE SHALL BE INCORPORATED TO THE EQUIPMENT POWERED BY 24 V AC POWER SUPPLY.
- ONLY CONNECT 24 V AC CLASS 2 POWER SUPPLY (UL 1310/CSA 223) or LIMITED POWER SOURCE (IEC/EN/UL/CSA 60950-1).
- ONLY CONNECT POWER OVER ETHERNET 54 V DC or PoE+ 54 V DC LIMITED POWER SOURCE (IEC/EN/UL/CSA 60950-1).

In the case of the use of a 24 V AC power supply, connect the output of the 24 V AC power supply to the 24 V AC power supply connector (accessory) with the contact (accessory). Then, connect the 24 V AC power supply connector to the power supply terminal (24 V AC).

IMPORTANT:

- Be sure to use the 24 V AC power supply connector kit (accessory) provided with this product.
- Be sure to fully insert the 24 V AC power supply connector (accessory) into the power supply terminal (24 V AC). Otherwise, it may damage the camera or cause malfunction.
- When installing the camera, make sure that excessive force is not applied to the power supply terminal (24 V AC).
- Be sure to use an insulated 24 V AC power supply from a commercial power supply compliant with the Specifications (Indicated inside the SD slot cover at the rear part of the camera.) regarding power source and power consumption.

③ Audio input cable (white)

Connect a microphone or the line out of an external device using a stereo mini plug (ø3.5 mm). (Monaural input)

<For microphone input>

- Recommended microphone : Plug-in power type (locally procured)
(Sensitivity of microphone : -48 dB ±3 dB (0 dB=1 V/Pa, 1 kHz))
- Input impedance : Approx. 2 kΩ (unbalanced)
- Supply voltage : 4.0 V ±0.5 V
- Recommended cable length : Less than 1 m {3.28 feet}

<For line input>

- Input level for the line input : Approx. -10 dBV
- Recommended cable length : Less than 10 m {32.8 feet}

④ Audio output cable (black)

Connect an external speaker* using a stereo mini plug (ø3.5 mm). (Monaural output)

- Output impedance : Approx. 600 Ω (unbalanced)
- Recommended cable length : Less than 10 m {32.8 feet}
- Output level : -20 dBV * Use a powered speaker.

IMPORTANT:

- Connect/disconnect the audio input/output cables and turn on the power of the camera after turning off the power of the audio output devices. Otherwise, loud noise may be heard from the speaker.
- Make sure that the stereo mini plug is connected to this cable. When a monaural mini plug is connected, audio (Image: when audio output is switched to monitor output) may not be heard. When connecting a monaural speaker with amplifier, use a locally procured conversion cable (mono-stereo).

Note:

- The audio output can be switched to the monitor output. Refer to the Operating Instructions on the Panasonic support website for descriptions of how to switch the output.
 - The video output is set to NTSC in the default settings of the camera. If you want to change the video output setting to PAL, refer to the Operating Instructions on the Panasonic support website.
-

⑤ Alarm input/output cable / 8P alarm cable (accessory)

Connect the 8P alarm cable (accessory) to the alarm input/output cable. Then, connect the external device cable to the 8P alarm cable.

Note:

- Off, input, and output of the ALARM IN2 and 3 can be switched by configuring the setting. Refer to the Operating Instructions on the Panasonic support website for further information about the ALARM IN2 and 3 settings (“Off”, “Alarm input”, “Alarm output” or “AUX output”).
-

<Ratings>

- Alarm input1 / Black & white input / Auto time adjustment input, Alarm input2, Alarm input3
Input specification : No-voltage make contact input (4 V – 5 V DC, internally pulled up)
OFF : Open or 4 V – 5 V DC
ON : Make contact with GND (required drive current: 1 mA or more)
- ALARM OUT, AUX OUT
Output specification : Open collector output (maximum applied voltage: 20 V DC)
ON : 4 V – 5 V DC by internal pull-up
OFF : Output voltage 1 V DC or less (maximum drive current: 50 mA)

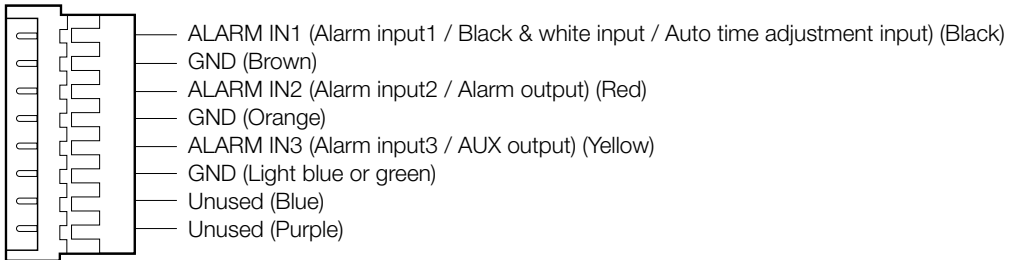
8P alarm cable

IMPORTANT:

- Install external devices so that they do not exceed the rating of the camera.
 - When using the ALARM IN2 and/or 3 as the output terminals, ensure they do not cause signal collision with external signals.
-

Connection example

Before starting the installation, check the entire system configuration.

When connecting with a PC directly

<Required cable> Ethernet cable (category 5e or better, cross)

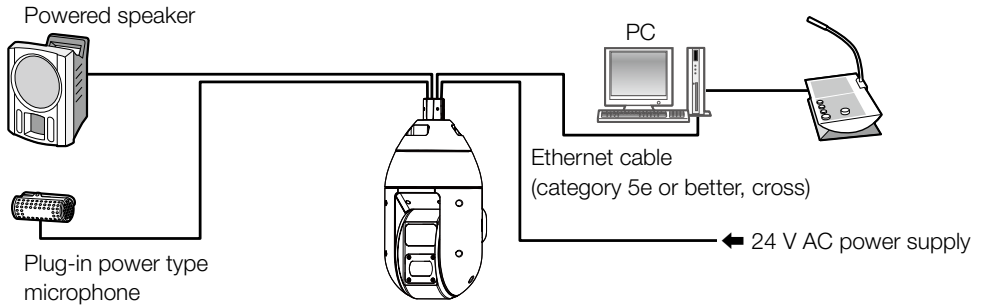

Connecting to a network using a PoE+ hub /device when the temperature is $-30\text{ }^{\circ}\text{C}$ $\{-22\text{ }^{\circ}\text{F}\}$ or less

When the temperature is $-30\text{ }^{\circ}\text{C}$ $\{-22\text{ }^{\circ}\text{F}\}$ or less, use a 24 V AC power supply or a tested PoE injector.

<Required cable> Ethernet cable (category 5e or better, straight)

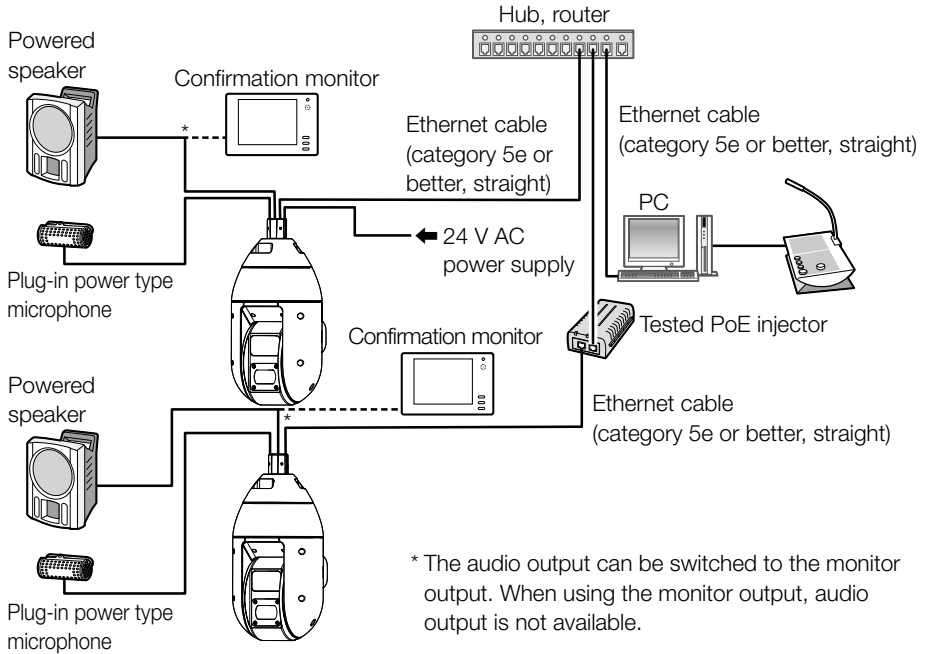

IMPORTANT:

- Use a switching hub or a router which is compliant with 10BASE-T/100BASE-TX.
- If a PoE+ hub is not used, each camera must be connected to a 24 V AC power supply.
- When using 24 V AC, power supply from a PoE+ hub or router is not required.

■ Indicators and Switch

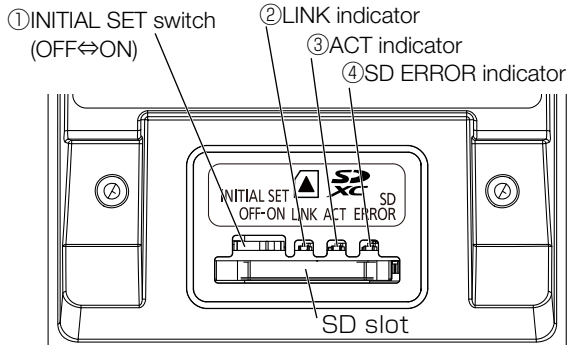

① INITIAL SET switch

Use the INITIAL SET switch to reset the settings of the camera to the default.

IMPORTANT:

- When the camera is initialized, the settings including the network settings will be initialized. Before initializing the settings, it is recommended to write down the settings in advance. Note that the preset position settings and the CRT key (SSL encryption key) used for the HTTPS protocol will not be initialized.
- Do not turn off the power of the camera during the process of initialization. Otherwise, it may fail to initialize and may cause malfunction.

Step 1

Turn off the power of the camera.

Step 2

Open the SD slot cover by following steps 1 of the “Insert an SD memory card” section (page 26).

Step 3

Move the INITIAL SET switch to the right (ON).

- The factory default is OFF.

Step 4

Move the INITIAL SET switch to the right, and then turn on the power of the camera. Turn on the power of the camera and turn off (move it to the left) the INITIAL SET switch about 15 seconds later.

Step 5

Attach the SD slot cover to the original position by following step 3 of the “Insert an SD memory card” section (page 26).

IMPORTANT:

- If the INITIAL SET switch is still positioned to the “ON” side, the camera cannot enter the normal operation mode. Be sure to return the INITIAL SET switch to the “OFF” position.

Step 6

If the [Run] button next to [IP Setting Software] is clicked, information such as the MAC address and the IP address, etc. of the camera are displayed in the [Panasonic IP Setting Software] screen. Select this camera, and click [Access Camera].

Step 7

Confirm that the administrator registration window is displayed.

Note:

- Repeat this operation if information such as the MAC address and the IP address, etc. of this camera are not displayed in the [Panasonic IP Setting Software] screen, or if the administrator registration window is not displayed.
 - Once the user name and password are registered in the administrator registration window, the panning, tilting, and zooming functions will all start to function automatically.
-

②LINK indicator

- When the camera is able to communicate with the connected device Lights orange

③ACT indicator

- When data is being sent via the camera Blinks green (accessing)

④SD ERROR indicator

- When the camera is being started Lights red
- When an SD memory card is recognized normally Lights red → Lights off
- When the SD slot is not used or an abnormality is detected in the SD memory card after the camera has started Lights red → Stays red

Insert/remove an SD memory card

Note:

- Refer to the Operating Instructions on the Panasonic support website for further information about the SD memory card settings.
 - Refer to our website (<https://security.panasonic.com/support/info/> <Control No.: C0107>) for latest information about the compatible SD memory cards.
-

■ Insert an SD memory card

[1] Either turn off the power supply to the camera, or else put the camera in the “Insert/Remove SD memory card” mode.

- Before inserting an SD memory card, please make sure to turn off the power of the camera.
 - When it is difficult to turn off the power of the camera, always put this camera in the “Insert/Remove SD memory card” mode.
-

Note:

- When “Insert/Remove SD memory card” mode is set, the position refresh function that automatically detects the positional displacement of PAN/TILT generated by an external force will be disabled. The removal of the SD slot cover is easier in this mode.
-

<How to set the “Insert/Remove SD memory card” mode>

- ① Click the [Setup] button in the “Live” page.
- ② After clicking the [Basic] button in the setup menu window, click the [SD Memory card] tab in the “Basic” page.
- ③ Click the [Execute] button of [Insert/Remove SD memory card] in the bottom-most part of the [SD Memory card] tab.
- ④ This camera then goes into the “Insert/Remove SD memory card” mode and “Now Maintenance Mode” is displayed in the screen.

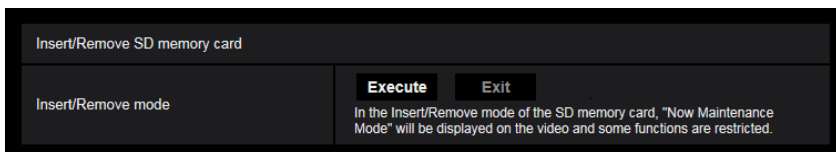

[2] Insert an SD memory card.

Step 1

Open the SD slot cover

Loosen 2 SD slot cover fixing screws (M4) at the rear part of the camera unit using a Phillips screwdriver, and open the SD slot cover.

Step 2

Insert an SD memory card

- Insert an SD memory card in the SD slot. Push in straight until the end and confirm that a clicking sound is heard.
- Take your fingers off the SD memory card and check that its back end does not protrude over the SD guide rib.

Step 3

Attach the SD slot cover to its original position.

Attach the SD slot cover again. Recommended tightening torque of the SD slot cover fixing screws: 1.38 N·m {1.02 lbf·ft}

SD slot cover fixing screws

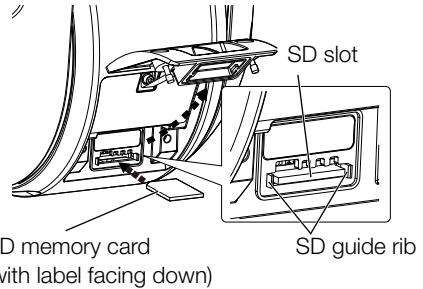
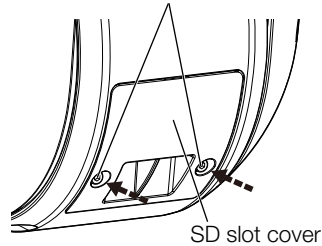

SD slot cover fixing screws

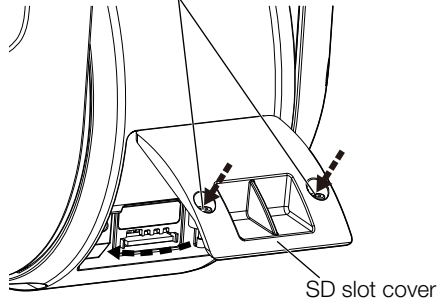

[3] Exit from the “Insert/Remove SD memory card” mode if it has been started.

<How to exit from the “Insert/Remove SD memory card” mode>

- ① Click the [Exit] button of [Insert/Remove SD memory card] in the bottom-most part of the [SD Memory card] tab.
- ② Normal operations are restored and the panning, tilting, and zooming functions will all start to function automatically.

■ Remove an SD memory card

- Even when removing an SD memory card, turn off the power of the camera.
- When it is difficult to turn off the power of the camera, always put this camera in the “Insert/Remove SD memory card” mode.
- When removing an SD memory card, reverse the procedure.
- Before removing the SD memory card, make sure to select “Not use” for “SD memory card” on the [SD memory card] tab of “Basic” page on the setup menu first.
- After removing the SD memory card, set SD memory card”to“Use” again on the [SD memory card] tab of “Basic” page on the setup menu.

Refer to the Operating Instructions on the Panasonic support website for further information about the setup menu.

Note:

- When using an SD memory card, format it using this product. Recorded data on the SD memory card will be deleted when formatted.
If an unformatted SD memory card or an SD memory card formatted with other devices is used, this product may not work properly or performance deterioration may be caused.
Refer to the Operating Instructions on the Panasonic support website for how to format an SD memory card.
 - When some SD memory cards are used with this product, the product may not work properly or performance deterioration may be caused. Use the compatible SD memory cards. (page 37)
 - If the [Execute] button of [Insert/Remove SD memory card] is clicked, accesses to the SD memory card are automatically stopped.
Also, if the [Exit] button is clicked, accesses to the SD memory card are started automatically.
-

Troubleshooting

Before asking for repairs, check the symptoms with the following table.

Contact your dealer if a problem cannot be solved even after checking and trying the solution in the table or a problem is not described below.

Symptom	Cause/solution	Reference pages
Power is not turned on.	<p>When using a PoE+ device for power supply</p> <ul style="list-style-type: none"> Are the PoE+ (IEEE802.3at compliant) device and the RJ45 (female) network cable of the camera connected using a Ethernet cable (category 5e or better)? Check whether the connection is appropriately established. Depending on the PoE+ device, the power supply will stop when the demanded power exceeds its total power limit for all PoE+ ports. Refer to the operating instructions of the PoE+ device in use. 	Installation Guide
	<p>When using AC power supply</p> <ul style="list-style-type: none"> Is the power cable connected firmly to power that meets the required specifications? Check whether the connection is appropriately established. Is the power supply connector housing attached to the camera firmly? Check if it is attached correctly and firmly. 	
	<p>When using a tested PoE injector</p> <ul style="list-style-type: none"> Is the power supply to the tested PoE injector turned ON? Confirm that the power lamp of the tested PoE injector has lit up. Are the connections to the tested PoE injector mistaken? Confirm that the Ethernet cable from this unit is connected to "DATA PWR OUT". Confirm that the Ethernet cable from the hub is connected to "DATA IN". 	22
The camera does not move to the preset positions accurately.	<ul style="list-style-type: none"> When the preset positions become inaccurate during use, it is possible to correct the positions by executing the position refresh function. In addition, when "Position refresh" is set for the created schedule, the camera position will be corrected periodically. In some situations, reconfigure the preset positions. 	Operating Instructions (on the Panasonic support website)
When the camera is panning/tilting, the camera stops panning/tilting and mechanical noise comes from the camera.	<ul style="list-style-type: none"> The camera position may have become inaccurate. Carry out the refresh position function from the [Default reset] tab of the "Maintenance" page of the setup menu. 	Operating Instructions (on the Panasonic support website)

Symptom	Cause/solution	Reference pages
The camera starts panning unpredictably.	<ul style="list-style-type: none"> • This may be caused by noise. Check the exogenous noise level around the camera. 	11
	<ul style="list-style-type: none"> • The protection circuit against high temperature may function. When the digital flip (function to turn the screen upside-down when tilting exceeds a certain angle) continues for a given time in high temperature, the system releases the digital flip and operates panning and tilting automatically to return the screen to the original position. • The position refresh may be done automatically to improve the positional accuracy of PAN, TILT and ZOOM when turned on in low temperature, which is not a failure. 	–
The LINK indicator does not light in orange even when the Ethernet cable is connected to the camera.	<ul style="list-style-type: none"> • Is the Ethernet cable connected appropriately? Connect the Ethernet cable appropriately. • Is the hub or router connected to the camera operating appropriately? Check if the hub or router in use is operating appropriately. • Isn't the Ethernet cable connected to the camera broken? Replace the cable with another one. 	18
Indicators never lights up.	<ul style="list-style-type: none"> • Is "Off" selected for "Indicator" on the "Basic" page? Select "On" or "On(Access)" for the indicator setting. 	Operating Instructions (on the Panasonic support website)
SD ERROR indicator lights red.	<p>This indicator lights up red when data cannot be saved on the SD memory card.</p> <ul style="list-style-type: none"> • Isn't the write protect switch of the inserted SD memory card set to "LOCK"? Unlock the write protect switch of the SD memory card. • Hasn't the inserted SD memory card been formatted on a PC? Use an SD memory card formatted on the camera. Or install the software to format the SD memory card on the PC. Refer to our website (<a href="https://security.panasonic.com/support/info/<Control No.: C0105>">https://security.panasonic.com/support/info/<Control No.: C0105>) for further information about the supported software. • Isn't the inserted SD memory card faulty? Replace the card with a normal one. 	24 - 27
Audio input contains noise.	<ul style="list-style-type: none"> • Check the following. <ul style="list-style-type: none"> • Grounding of the camera, a switching hub or peripheral devices are not done. • The camera is used near an electrical power line. • The camera is used near a device which produces strong magnetic field or radio waves (such as near a TV/radio antenna, a motor of an air conditioning system, a transformer, etc.) <p>When audio input still contains noise even after checking the above possibilities, use a powered microphone or connect audio output with low output impedance.</p>	16

Symptom	Cause/solution	Reference pages
<p>The power cable insulation is damaged.</p> <p>The power cable, plug and connectors get hot during use.</p> <p>The power cable gets hot when bent or stretched.</p>	<ul style="list-style-type: none"> The power cable and connectors are worn out. This may result in electric shock or a fire. Unplug the power cable from the power source immediately, and refer to qualified service personnel. 	<p>—</p>
<p>It is hard to see images with the camera when there are raindrops on the front panel.</p>	<ul style="list-style-type: none"> The effectiveness of the rain wash coating may have been reduced. Refer to “Cleaning of the front panel” in “Precautions for use” and clean the front panel. If the situation does not improve contact your dealer. 	<p>12</p>
<p>The image refresh interval on the web browser is longer or the image is displayed intermittently.</p>	<ul style="list-style-type: none"> When the camera is set to high frame rate and high image quality, and the hardware decode functions of the PC are to be used, the updating of the screen gets delayed due to the specifications of the CPU or memory of the PC. These cases may be improved by using a PC with the following specifications. CPU: Intel® Core™ i7-6700 or faster recommended Memory: 4 GB (2 GB x 2, dual channel) or more recommended 【Example of using the camera in case that the image refresh interval is longer or intermittent】 Image capture size: 1920×1080, Frame rate: 60 fps, Bit rate: 4096 kbps Image capture size: 1280×720, Frame rate: 60 fps, Bit rate: 3072 kbps Image capture size: 1280×720, Frame rate: 30 fps, Bit rate: 2048 kbps (When referring to multiple browsers 4 images or more) 	<p>6</p>
<p>Normal PAN and TILT operations are not made even when the power supply to the camera has been turned on. A sound comes from the camera.</p>	<ul style="list-style-type: none"> Have you not turned on the camera with the fixing tapes still adhered on the camera? Immediately turn off the power supply of the camera, remove the fixing tape adhered to the horizontal and vertical rotation portions of the camera, and then turn on the power again. A sound coming from the camera does not mean it has developed a problem. If the fixing tape is removed and the power supply is turned on again, the camera returns to normal operation. 	<p>Installation Guide</p>

Symptom	Cause/solution	Reference pages
<p>“Now Maintenance Mode” is still being displayed in the screen.</p>	<ul style="list-style-type: none"> The camera is still in the “Insert/Remove SD memory card” mode. Click the [Exit] button of [Insert/Remove SD memory card]. 	<p>25, 26</p>
<p>“Power supply is operating on PoE” is still being displayed in the screen.</p>	<ul style="list-style-type: none"> Operating on PoE. Use a PoE+ hub / device that is compliant with IEEE802.3at standard. It is impossible to supply the power to this product from a PoE hub that is compliant with IEEE802.3af standard. 	<p>–</p>

Specifications

• Basic

Power source *1:	AC 24 V (50 Hz/60 Hz) PoE+ device (IEEE802.3at compliant) Tested PoE injector (60 W)
Power consumption *1:	AC 24 V : 3.4 A/Approx. 55 W PoE+ DC 54 V: 470 mA/Approx. 25 W (Class4 device) Tested PoE injector (60 W) DC 54 V: 1.0 A/Approx. 50 W
Operating environment Ambient operating temperature:	When using a 24 V AC power supply / tested PoE injector (60 W) -50 °C to +60 °C {-58 °F to +140 °F} *2 X6533 -40 °C to +60 °C {-40 °F to +140 °F} *2 S6532 (Power On range: -30 °C to +60 °C {-22 °F to +140 °F}) When using a PoE+ hub / device -30 °C to +60 °C {-22 °F to +140 °F} *2
Ambient operating humidity:	10 % to 100 % (no condensation)
Storage environment Storage temperature:	-50 °C to +70 °C {-58 °F to +158 °F}
Storage humidity:	10 % to 95 % (no condensation)
EXT I/O terminals:	ALARM IN1 (Alarm input 1/ Black & white input/ Auto time adjustment input) (x1) ALARM IN2 (Alarm input 2/ ALARM OUT) (x1) ALARM IN3 (Alarm input 3/ AUX OUT) (x1)
Audio input: For microphone input:	ø3.5 mm stereo mini jack (Monaural input) Recommended applicable microphone: Plug-in power type (Sensitivity of microphone: -48 dB±3 dB (0 dB=1 V/Pa, 1 kHz)) Input impedance: Approx. 2 kΩ (unbalanced) Supply voltage: 4.0 V ±0.5 V
For line input:	Input level: Approx. -10 dBV
Audio output*3:	ø3.5 mm stereo mini jack (Monaural output) Output impedance: Approx. 600 Ω (unbalanced) Output level: -20 dBV
Waterproof*4:	IP66 (IEC 60529), Type 4X (UL50E) NEMA 4X compliant
Shock resistance:	IK10 (IEC 62262)
Wind resistance:	Up to 40 m/s {approx. 89 mph}
Dimensions:	Maximum ø249 mm × 465 mm (H) {ø9-13/16 inches × 18-5/16 inches (H)}
Mass:	Approx. 8.2 kg {18.10 lbs} (Including attachment pipe: Approx. 200 g {0.44 lbs} and cable cover)
Finish:	Main body: Aluminum die cast, Fine silver Outer fixing screws: Stainless steel (Corrosion-resistant treatment) Front panel: Polycarbonate resin (with ClearSight coating (rain wash coating)), Clear

- *1 Refer to our website (<https://security.panasonic.com/support/info/> <Control No.: C0106>) for further information about Power source and Power consumption information.
- *2 When using with the IR LED light constantly lit, the upper limit of the operating temperature range is +45°C (+113 °F).
- *3 The audio output can be switched to the monitor output. Refer to the Operating Instructions on the Panasonic support website for descriptions of how to switch the output.
- *4 Only when installation work is properly performed according to the Installation Guide and appropriate waterproof treatment is performed.

• Camera

Image sensor:	1/2.8 type CMOS image sensor
Effective pixels:	Approx. 2.1 megapixels
Scanning area:	5.57 mm (H) × 3.13 mm (V) {7/32 inches (H) × 1/8 inches (V)}
Scanning system:	Progressive
Minimum illumination:	Color : 0.015 lx {0.00139 footcandle} (F1.6, Maximum shutter: Off (1/30 s), AGC: 11) 0.001 lx {0.00009 footcandle} (F1.6, Maximum shutter: max. 16/30 s, AGC: 11)* BW : 0 lx {0 footcandle} (F1.6, Maximum shutter: OFF (1/30 s), AGC: 11, when the IR LED is lit) 0.006 lx {0.00056 footcandle} (F1.6, Maximum shutter: Off (1/30 s), AGC: 11) 0.0004 lx {0.00004 footcandle} (F1.6, Maximum shutter: max. 16/30 s, AGC: 11)* * Converted value
Intelligent auto:	On/ Off
Super Dynamic:	On/ Off The level can be set in the range of 0 to 31. (When 60 fps is selected, the Super Dynamic function is automatically set to off.)
Dynamic range:	144 dB typ. (Super Dynamic: On)
Maximum gain:	The level can be set in the range of 0 to 11.
Auto contrast adjust:	On/ Off
Adaptive black stretch:	The level can be set in the range of 0 to 255.
Back light compensation (BLC) /High light compensation (HLC):	BLC/ HLC/ Off The level can be set in the range of 0 to 31. (only when Super Dynamic/ Intelligent auto: Off)
Fog compensation:	On/ Off The level can be set in the range of 0 to 8. (only when Intelligent auto/ auto contrast adjust: Off)
Light control mode setting:	Outdoor scene/ Indoor scene (50 Hz)/ Indoor scene (60 Hz)/ Fix shutter
Shutter speed:	1/30 Fix, 3/120 Fix, 2/100 Fix, 2/120 Fix, 1/60 Fix, 1/100 Fix, 1/120 Fix, 1/250 Fix, 1/500 Fix, 1/1000 Fix, 1/2000 Fix, 1/4000 Fix, 1/10000 Fix (1/30 Fix to 2/120 Fix is available during 30 fps mode only.) (1/60 Fix is available during 60 fps mode only.)
Maximum shutter:	Max.1/4000 s, Max.1/2000 s, Max.1/1000 s, Max.1/500 s, Max.1/250 s, Max.1/120 s, Max.1/100 s, Max.2/120 s, Max.2/100 s, Max.3/120s, Max.1/30 s, Max.2/30 s , Max.4/30 s, Max.6/30 s, Max.10/30 s, Max.16/30 s (Max.2/100 s and Max.3/120 s are available during 30 fps mode only.)

Color/BW:	Off/ On(IR Light Off)/ On(IR Light On)/ Auto1(IR Light Off)/ Auto2(IR Light On)
IR LED Light:	High/ Middle/ Low/ Off Maximum irradiation distance X6533 When using a 24 V AC power supply / tested PoE injector (60 W): 350 m {Approx. 1150 ft} When using a PoE+ hub /device: 150 m {Approx. 500 ft} S6532 100 m {Approx. 330 ft}
White balance:	ATW1/ ATW2/ AWC
Digital noise reduction:	The level can be set in the range of 0 to 255.
Stabilizer:	On/ Off (available only in the 30 fps mode)
Privacy zone:	Filling/ Pixelate/ Off (up to 32 zones available)
Camera title on screen:	On/ Off Up to 20 characters (alphanumeric characters, marks)
Video Motion Detection (VMD):	On/ Off 4 areas available

• Lens

	WV-X6533LN	WV-S6532LN
Zoom ratio:	40x Optical zoom 60x with HD Extra Optical Zoom *1 (Motorized zoom / Motorized focus)	22x Optical zoom 34x with HD Extra Optical Zoom *1 (Motorized zoom / Motorized focus)
Digital (electronic) zoom:	16x (Max 640x)	16x (Max 358x)
Focal length:	4.25 mm – 170 mm {5/32 inches – 6-11/16 inches}	4.25 mm – 95 mm {5/32 inches – 3-3/4 inches}
Maximum aperture ratio:	1:1.6 (WIDE) – 1:4.95 (TELE)	1:1.6 (WIDE) – 1:3.7 (TELE)
Focus range:	3 m {9ft 10-1/8 inches} – ∞	
Aperture range:	F1.6 – Close	
Angular field of view:	[16:9 mode] Horizontal: 1.9° (TELE) – 66° (WIDE) Vertical: 1.1° (TELE) – 39° (WIDE) [4:3 mode] Horizontal: 1.4° (TELE) – 51° (WIDE) Vertical: 1.1° (TELE) – 39° (WIDE)	[16:9 mode] Horizontal: 3.4° (TELE) – 66° (WIDE) Vertical: 2.0° (TELE) – 39° (WIDE) [4:3 mode] Horizontal: 2.6° (TELE) – 51° (WIDE) Vertical: 2.0° (TELE) – 39° (WIDE)

*1 Resolution 1280×720.

• **Panning/tilting platform**

Panning range:	360° Endless panning
Panning speed:	Manual: Approx. 0.065°/s – 150°/s Preset: Up to approx. 300°/s
Tilting range:	Operational range: –30° – 210° (level – downward – level) Recommended range *1: 0° – 180°
Tilting speed:	Manual: Approx. 0.065°/s – 150°/s Preset: Up to approx. 300°/s
Number of the preset positions:	256
Auto mode:	Auto track/ Auto pan/ Preset sequence/ Patrol
Self return:	10 s/ 20 s/ 30 s/ 1 min/ 2 min/ 3 min/ 5 min/ 10 min/ 20 min/ 30 min/ 60 min

*1 The recommended range is a guideline for using without the screen being cut. If the lens is tilted up beyond this, a part of the screen may become hidden.

• **Network**

Network:	10BASE-T/100BASE-TX, RJ45 connector
Resolution *1: H.265/ H.264 JPEG (MJPEG)	<p>[16:9 mode] 1920×1080, 1280×720, 640×360, 320×180</p> <p>[4:3 mode] 2048×1536 *2, 1280×960, 800×600, VGA, 400×300, QVGA</p>
Image compression method *3: H.265/ H.264	<p>Transmission priority: Constant bit rate/ VBR/ Frame rate/ Best effort</p> <p>Frame rate: 1 fps/ 3 fps/ 5 fps*/ 7.5 fps*/ 10 fps*/ 12 fps*/ 15 fps*/ 20 fps*/ 30 fps*/ 60 fps*</p> <p>* The frame rate is limited to “bit rate”. When a value with an asterisk (*) is selected, the actual frame rate may be lower than the value selected.</p> <p>Bit rate per client: 64 kbps/ 128 kbps*/ 256 kbps*/ 384 kbps*/ 512 kbps*/ 768 kbps*/ 1024 kbps*/ 1536 kbps*/ 2048 kbps*/ 3072 kbps*/ 4096 kbps*/ 6144 kbps*/ 8192 kbps*/ 10240 kbps*/ 12288 kbps*/ 14336 kbps*/ 16384 kbps*/ 20480 kbps*/ 24576 kbps*/ --FREE ENTRY--</p> <p>* The available range of the bit rate varies depending on the setting selected for “image capture size”.</p> <p>Image quality:</p> <ul style="list-style-type: none"> • For “Constant bit rate”, “Frame rate”, and “Best effort”: Motion priority/ Normal/ Quality priority • “VBR”: 0 Super fine/ 1 Fine/ 2/ 3/ 4/ 5 Normal/ 6/ 7/ 8/ 9 Low <p>Transmission type: Unicast/ Multicast</p>
JPEG (MJPEG)	<p>Image quality: 0 SUPER FINE/ 1 FINE/ 2/ 3/ 4/ 5 NORMAL/ 6/ 7/ 8/ 9 LOW (10 steps: 0-9)</p> <p>Transmission type: Pull/ Push</p> <p>Refresh interval: 0.1 fps/ 0.2 fps/ 0.33 fps/ 0.5 fps/ 1 fps/ 2 fps/ 3 fps/ 5 fps/ 6 fps/ 10 fps/ 12 fps/ 15 fps/ 30 fps (JPEG frame rates are limited when using JPEG and H.265/H.264 simultaneously)</p>
Smart coding:	<p>Smart Facial Coding* On(Smart Facial Coding)/ On(AUTO VIQS)/ Off * Smart Facial Coding is only available with Stream(1).</p> <p>GOP(Group of pictures) control On(Frame rate control)*/ On(Advanced)*/ On(Mid)/ On(Low)/ Off * On(Frame rate control) and On(Advanced) is only available with H.265.</p>
Audio compression method:	G.726 (ADPCM) : 16 kbps/ 32 kbps G.711 : 64 kbps AAC-LC *4 : 64 kbps/ 96 kbps/ 128 kbps
Bandwidth control:	Unlimited/ 64 kbps/ 128 kbps/ 256 kbps/ 384 kbps/ 512 kbps, 768 kbps/ 1024 kbps/ 2048 kbps/ 4096 kbps/ 6144 kbps/ 8192 kbps/ 10240 kbps/ 15360 kbps/ 20480 kbps/ 25600 kbps/ 30720 kbps/ 35840 kbps/ 40960 kbps/ 51200 kbps
Protocol:	IPv6: TCP/IP, UDP/IP, HTTP, HTTPS, FTP, SMTP, DNS, NTP, SNMP, DHCPv6, RTP, MLD, ICMP, ARP, IEEE 802.1X, DiffServ IPv4: TCP/IP, UDP/IP, HTTP, HTTPS, RTSP, RTP, RTP/RTCP, FTP, SMTP, DHCP, DNS, DDNS, NTP, SNMP, UPnP, IGMP, ICMP, ARP, IEEE 802.1X, DiffServ

Security:	User authentication, Host authentication, HTTPS*, Alteration detection of video file* * The certification is pre-installed.
OS *5:	Microsoft Windows 10 Microsoft Windows 8.1 Microsoft Windows 7
Browser *5:	Internet Explorer 11 (32-bit)
Maximum concurrent access number:	14* (Number of sessions that can connect to cameras at the same time) * Depends on network conditions
FTP client:	Alarm image transmission, FTP periodic transmission (When the FTP transmission is failed, backup on an optional SD memory card is available.)
Multi-screen:	Up to 16 camera images can be displayed simultaneously on a multi-screen. (Including the camera itself)
Compatible SDXC/SDHC/SD memory card *6, *7, *8:	Manufactured by Panasonic (SD speed class 6 or higher) SDXC memory card : 64 GB, 128 GB, 256 GB SDHC memory card : 4 GB, 8 GB, 16 GB, 32 GB SD memory card : 2 GB (except miniSD memory card and microSD memory card)
Cellular phone compatibility:	JPEG image, AUX control (by access level)
Mobile terminal compatibility: (As of May, 2019) *9	iPad / iPhone (iOS 4.2.1 or later), Android™ mobile terminals

*1 H.265/H.264 can be selected for each stream.

*2 Used by super resolution techniques.

*3 Transmission for 4 streams can be individually set.

*4 When recording audio on an SD memory card, only use AAC-LC (Advanced Audio Coding - Low Complexity).

*5 For further information about PC system requirements and precautions for when using Microsoft Windows or Internet Explorer, click "Manual" - "Open" from the supplied CD-ROM and refer to "Notes on Windows / Internet Explorer versions".

*6 For possible number of images and duration (an indication) that can be saved on the SD memory card, refer to our website below.

<https://security.panasonic.com/support/info/>

Possible number of JPEG images that can be saved: <Control No.: C0306>

Possible duration of stream images (H.265 or H.264) that can be saved: <Control No.: C0307>

*7 Refer to our website (<https://security.panasonic.com/support/info/> <Control No.: C0107>) for latest information about the compatible SD memory cards.

*8 When repeatedly recording images on an SD memory card using the auto overwrite function, make sure to use an SD memory card with high reliability and durability.

*9 For further information about compatible devices, refer to our website (<https://security.panasonic.com/support/info/> <Control No.: C0108>).

Optional accessories

Ceiling mount bracket:	WV-Q121B
Wall mount bracket (Fine silver) :	WV-Q122A
Wall mount bracket (Light gray) :	WV-Q185
Pole mount bracket (Fine silver) :	WV-Q188 *1
Pole mount bracket (Light gray) :	WV-Q182 *2
Corner mount bracket (Fine silver) :	WV-Q189 *1
Corner mount bracket (Light gray) :	WV-Q183 *2

*1 After assembling WV-Q188 or WV-Q189 with WV-Q122A, attach them to the pole or corner of the wall of the building.

*2 After assembling WV-Q182 or WV-Q183 with WV-Q185, attach them to the pole or corner of the wall of the building.

Note:

- The brackets are available in two colors, fine silver and light gray. It is possible to use them in the different color combination.
-

For U.S. and Canada:

Panasonic Corporation of North America

Two Riverfront Plaza, Newark, NJ 07102-5490
<http://business.panasonic.com/>

Panasonic Canada Inc.

5770 Ambler Drive, Mississauga, Ontario, L4W 2T3 Canada
1-877-495-0580
<https://www.panasonic.com/ca/>

For Europe and other countries:

Panasonic Corporation

<http://www.panasonic.com>

Panasonic Corporation
Osaka, Japan

Authorised Representative in EU:

Panasonic Testing Centre
Panasonic Marketing Europe GmbH
Winsbergring 15, 22525 Hamburg, Germany

